

Service Manual

Colour Television

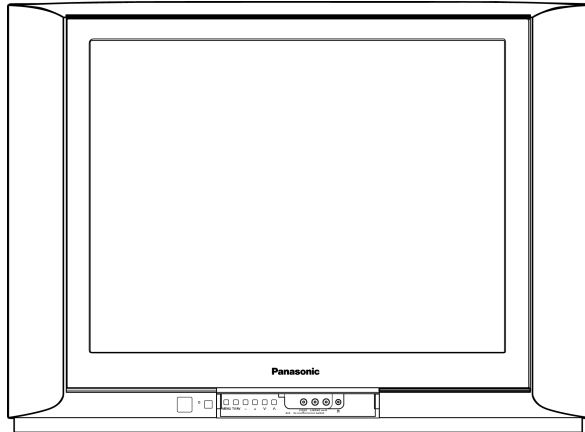

TC-29FX20R

GP41 Chassis

Specifications

Power Source :	AC AUTO 110-240V, 50/60 Hz	PR	0.7Vp-p, 75Ω
Power Consumption :	98W	AV 1,2,3	
Aerial Impedance :	75Ω unbalanced	Video In	1Vp-p, 75Ω
	Coaxial type	Audio In	Approx. 0.5V, 47kΩ
Receiving System :	17 Systems	Monitor Out	
Receiving Channels :		Video Out	1Vp-p, 75Ω
VHF	2-12 PAL / SECAM B,K1	Audio Out	Approx. 0.5V, 1kΩ
	0-12 PAL B (AUST)		
	1-9 PAL B (N.Z)	Intermediate Frequency :	
	1-12 PAL/SECAM D	Video	38.0 MHz
	1-12 NTSC M (JAPAN)	Sound	31.5 MHz (D, K, K1)
	2-13 NTSC M (U.S.A)		32 MHz (I)
UHF	21-69 PAL G,H,I / SECAM G,K,K1		32.5 MHz (B, G)
	28-69 PAL B (AUST)		33.5 MHz (M)
	13-57 PAL D,K	Colour	33.57 MHz (PAL)
	13-62 NTSC M (JAPAN)		33.6 MHz (SECAM)
	13-69 NTSC M (USA)		33.75 MHz (SECAM)
CATV	S1-S20 (OSCAR)		34.42 MHz (NTSC)
	1-125 (U.S.A CATV)	High Voltage :	31.0kV ±1.0
	C13-C49 (JAPAN)		at zero beam current
	S21-S41 (HYPER)	Picture Tube :	A68LZU185X-E
	Z1-Z37 (CHINA)		67.6cm (29 inches)
	5A, 9A (AUST)		Measured diagonally,
Video / Audio Terminals :			90° deflection
DVD		Audio Output :	16.0W
Y	1.0Vp-p, 75Ω	Dimensions :	Height : 578 mm
PB	0.7Vp-p, 75Ω		Width : 786 mm

Panasonic®

© 2006 Matsushita Electric Industrial Co., Ltd. All rights reserved. Unauthorized copying and distribution is a violation of law.

Depth : 508 mm

Specifications are subject to change without notice.

Mass :

43 kg (Net Wt.)

Mass and dimensions shown are approximate.

⚠ WARNING

This service information is designed for experienced repair technicians only and is not designed for use by the general public. It does not contain warnings or cautions to advise non-technical individuals of potential dangers in attempting to service a product. Products powered by electricity should be serviced or repaired only by experienced professional technicians. Any attempt to service or repair the product or products dealt with in this service information by anyone else could result in serious injury or death.

CONTENTS

	Page		Page
1 Safety Precautions	3	2.4. Adjustment Procedure	6
1.1. General Guide Lines	3	2.5. Adjustment	7
1.2. Leakage Current Cold Check	3	3 Conductor Views	9
1.3. Leakage Current Hot Check (Fig. 1)	3	4 Schematic Diagram	10
1.4. X-Radiation	3	4.1. A Board	12
1.5. GP41 Chassis Block Diagram	4	4.2. L Board	17
2 Service Hints	5	4.3. G Board	20
2.1. Service Position for E-Board	5	5 Parts Locations	24
2.2. Adjustment for White Balance	5	6 Replacement Parts List	25
2.3. Adjustment for CRT CUT OFF	5	6.1. Replacement Parts List	26

1 Safety Precautions

1.1. General Guide Lines

1. It is advisable to insert an isolation transformer in the AC supply before servicing this hot chassis.
2. When servicing, observe the original lead dress, especially the lead dress in the high voltage circuits. If a short circuit is found, replace all parts which have been overheated or damaged by the short circuit.
3. After servicing, see to it that all the protective devices such as insulation barriers, insulation papers, shields and isolation R-C combinations, are properly installed.
4. When the receiver is not to be used for a long period of time, unplug the power cord from the AC cord outlet.
5. Potential, as high as **32.0kV** is present when this receiver is in operation. Operation of the receiver without the rear cover involves the danger of a shock hazard from the receiver power supply. Servicing should not be attempted by anyone who is not thoroughly familiar with the precautions necessary when working on high voltage equipment. Always discharge the anode of the picture tube to the receiver chassis before handling the tube. After servicing make the following leakage current checks to prevent the customer from being exposed to shock hazards.

1.2. Leakage Current Cold Check

1. Unplug the AC cord and connect a jumper between the two prongs on the plug.
2. Turn on the receiver's power switch.
Measure the resistance value, with an ohmmeter, between the jumper AC plug and each exposed metallic cabinet part on the receiver, such as screw heads, aerials, connectors, control shafts, etc. When the exposed metallic part has a return path to the chassis, the reading should be between 4 M Ω and 20 M Ω . When the exposed metal does not have a return path to the chassis, the reading must be infinite.

1.3. Leakage Current Hot Check (Fig. 1)

1. Plug the AC cord directly into the AC outlet. Do not use an isolation transformer for this check.
2. Check a 2 k Ω non-inductive resistor and an AC/DC current meter, in series with each exposed metallic part on the receiver in turn and an earth such as a water pipe.

The current from any point should not exceed 0.7 mA peak AC or 2 mA DC. In the case of a measurement being outside of these limits specified, there is a possibility of a shock hazard and the receiver should be repaired and rechecked before it is returned to the customer.

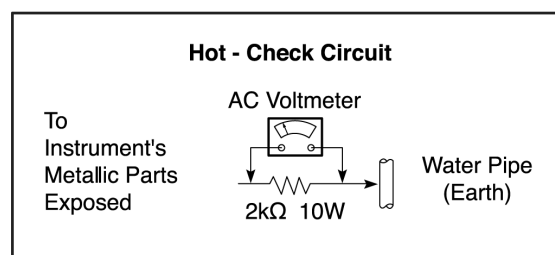

Fig. 1

1.4. X-Radiation

Warning:

The potential sources of X-Radiation in TV set are the EHT section and the picture tube. When using a picture tube test jig for service, ensure that jig is capable of handling **32.0kV** without causing X-Radiation.

Note: It is important to use an accurate periodically calibrated high voltage meter.

1. Set the brightness to minimum.
2. Use the remocon to get into Service Mode.
3. Measure the EHT. The meter reading should indicate **31.0 \pm 1.0kV**. If the meter indication is out of tolerance, immediate service and correction is required to prevent the possibility of premature component failure.
4. To prevent the possibility X-Radiation, it is essential to use the specified picture tube, if service replacement becomes necessary.

1.5. GP41 Chassis Block Diagram

GP41 CHASSIS BLOCK DIAGRAM

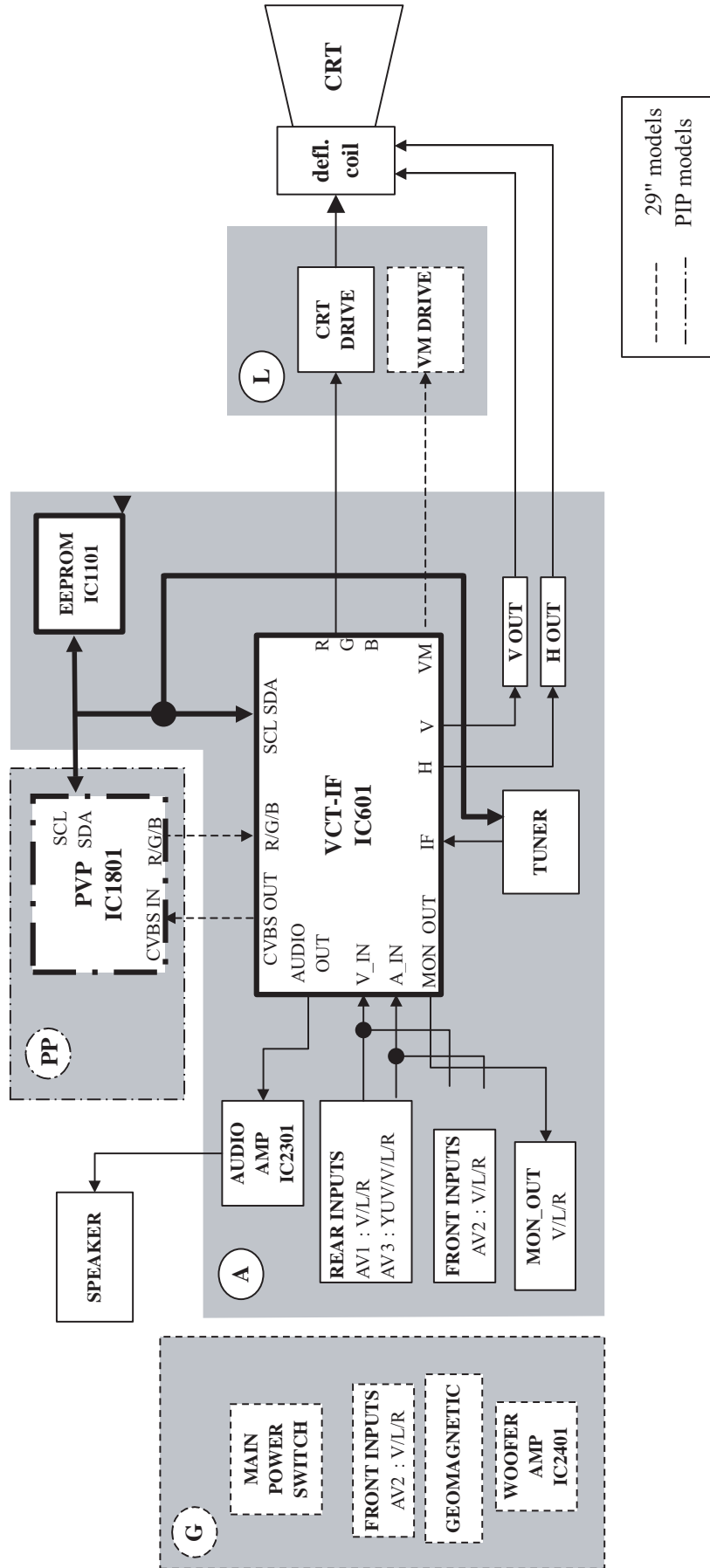

2 Service Hints

2.1. Service Position for E-Board

1. Remove the back cover.
2. Stand the TV set as shown in Fig. 2.
3. Remove the A-Board from the TV set by pulling the main board out as shown in Figure 2.

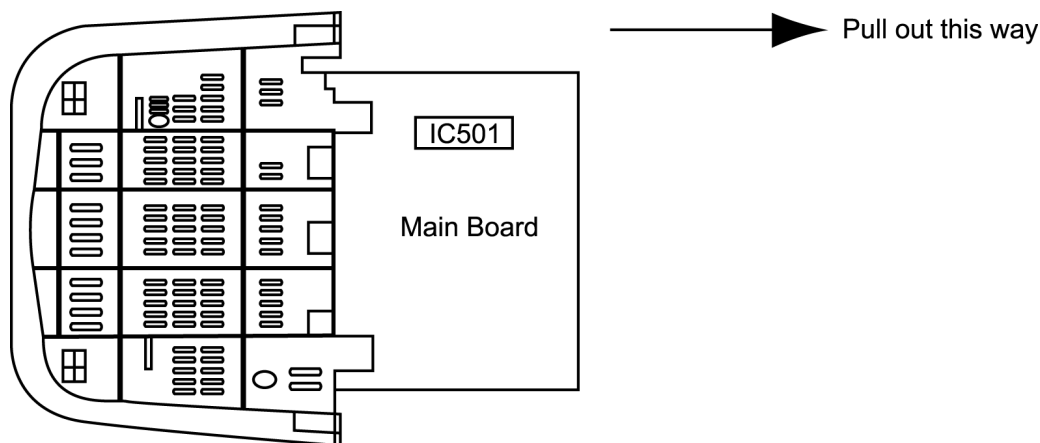

Fig. 2

2.2. Adjustment for White Balance

Preparation:

1. Receive the white balance pattern and aging should have been performed over 30 minutes.
2. Set the picture menu to DYNAMIC NORMAL.
3. Degauss the CRT face.
4. Fix the CRT colour analyzer receiver unit to CRT face.

Adjustment of Low Light.

1. Adjustment Sub Bright, so that $Y = 6.3 \pm 1.0$ nit.
2. Adjustment R-CUT OFF, so that $X = 0.247 \pm 0.005$ nit.
3. Adjustment G-CUT OFF, so that $Y = 0.273 \pm 0.005$ nit.

Adjustment of High Light

1. Adjustment Sub Bright, so that $Y = 150$ nit.
2. Adjustment R-Drive, so that $X = 0.261 \pm 0.003$ nit.
3. Adjustment B-Drive, so that $Y = 0.267 \pm 0.003$ nit.

2.3. Adjustment for CRT CUT OFF

Preparation:

1. Connect the oscilloscope probe to (GREEN CATHODE) on L Board.
2. Screen VR min.
3. Set the data Sub Bright, Bright.
4. In service Mode at "Bright" dac press [5] in factory mode to enter vertical line and adjust by volume down or up button.
5. Adjust "Screen VR" to set voltage as in table 1.

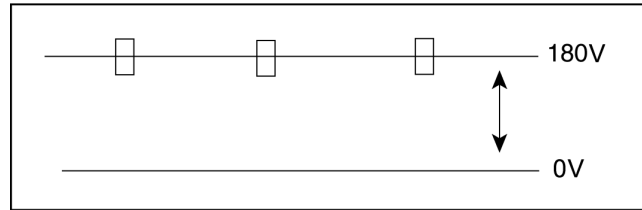

Table 1

2.4. Adjustment Procedure

2.4.1. +B Voltage

Item / preparation

1. Operate the TV set.
2. Set control as follows :
 - Brightness minimum
 - Contrast minimum

Adjustment procedure

1. Confirm the DC voltage at the indicated test points, as follows :
 - TPA 15 : $3.35 \pm 0.2V$
 - TPA 16 : $141 \pm 2V$
 - TPA 17 : $8.2 \pm 0.3V$
 - TPA 18 : $1.9 \pm 0.2V$
 - TPA19 : $5.2 \pm 0.2V$
 - TPA20 : $220 \pm 15V$

2.4.2. High Voltage

Item / preparation

1. Receive the crosshatch pattern.
2. Set to 0 Beam.
 - Screen VR minimum
 - Contrast minimum

Adjustment procedure

1. Connect a DC voltage meter to TPA 16 and confirm the +B voltage is $141.0 \pm 2V$.
2. Connect a high frequency voltmeter to heater and confirm that voltage reads 6.3 ± 0.24 (VRMS).
3. Normalize the brightness and contrast.

2.5. Adjustment

Before Colour Purity, Convergence and White Balance adjustment are attempted, V. Height, H. Centre and Focus adjustments must be completed.

Colour Purity

1. Set the Brightness and Contrast controls to their maximum positions.
2. Operate the TV set for 60 minutes.
3. Fully degauss the picture tube by using an external degaussing coil.
4. Apply a crosshatch pattern signal and adjust the static convergence magnets to the approximately correct position.
5. Receive a black and white signal.
6. Set the control as follows:
 Red.....minimum
 Green.....minimum
 Blue.....minimum
 Press the Shipping button on the remote control twice to select CRT Adjustment Mode to select low light.
7. Loosen the clamp screw for the Deflection Yoke A in Fig. 10 and move the Deflection Yoke as close to the purity magnet as possible.
8. Adjust the purity magnetic rings so that a vertical green field is obtained at the centre of the screen.

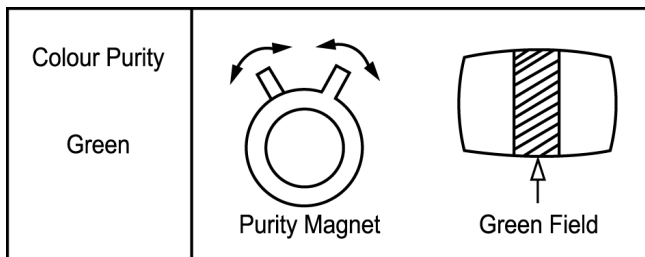

Fig. 6

9. Slowly push the Deflection Yoke and set it where a uniform green field is obtained.

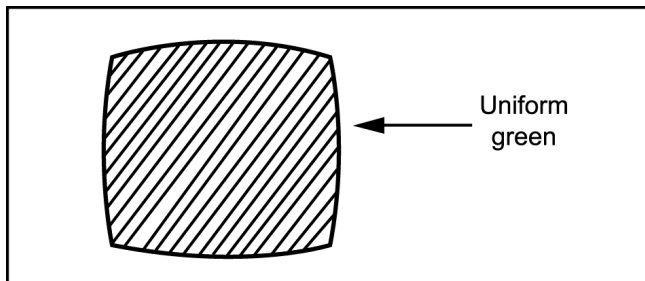

Fig. 21

10. Re-adjust the Low Light controls to their correct settings and make sure that a uniform white field is obtained.
11. Tighten the clamp screw A in Fig. 10.

Convergence

1. Apply a crosshatch pattern signal and Normalize Contrast control to the maximum positions.
2. Adjust Brightness until the grey position of the crosshatch pattern just becomes black.
3. Adjust the Red and Blue line at the centre of the screen by rotating the R-B static.

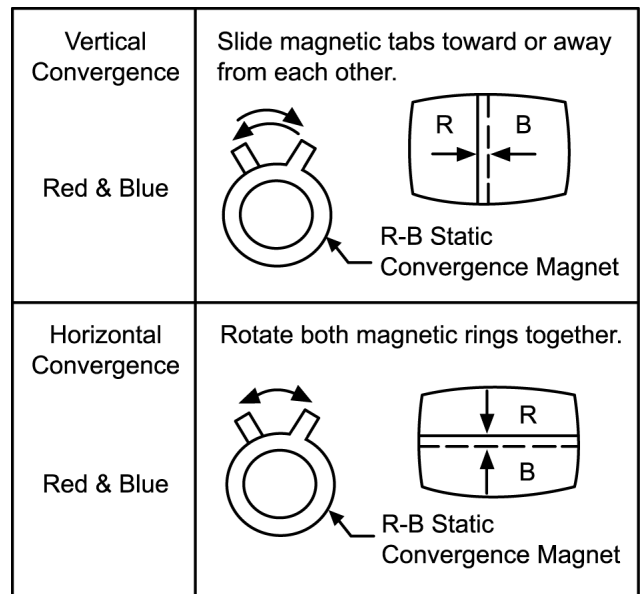

Fig. 8

4. Adjust Red and Blue with Green line at centre of the screen by rotating (RB)-G static convergence magnetic rings.
5. Lock convergence magnets with silicone sealer.
6. Remove the DY wedges and slightly tilt the Deflection Yoke vertically and horizontally to obtain the good overall convergence.

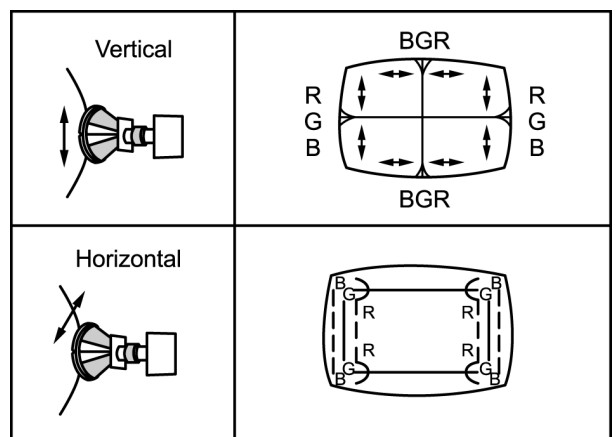

Fig. 9

7. Fix the Deflection Yoke by reinserting the DY wedges. Refer to Fig. 10.
8. If purity error is found, repeat "Colour Purity" adjustment.

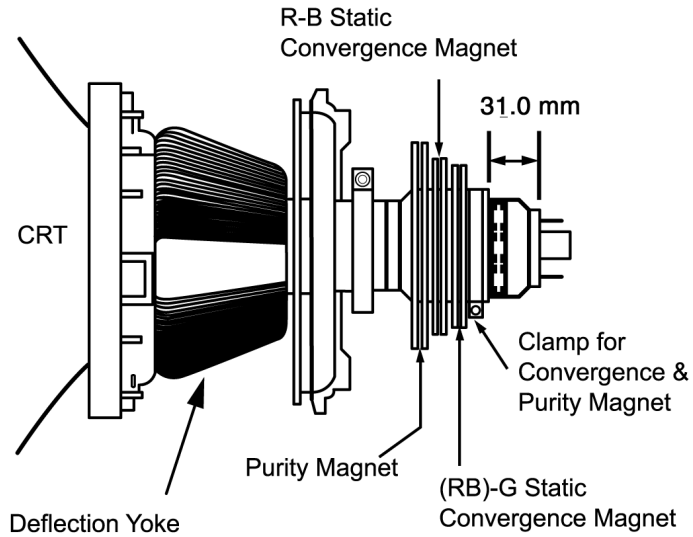

Fig. 10

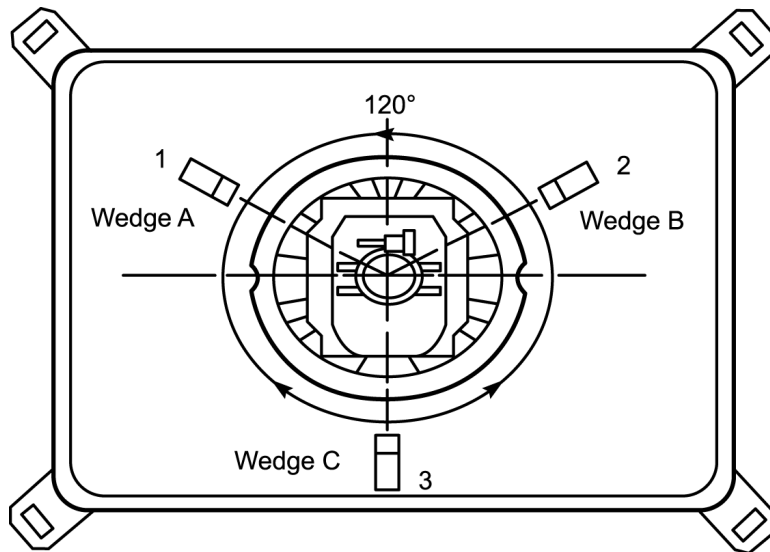



Fig. 11

Notes:

1. Wedge A, B and C should be inserted following the sequence of 1, 2 and 3 shown in Fig. 11.
2. The wedges should be set 120° apart from each other.
3. Be certain that three wedges are firmly fixed and the Deflection Yoke is tightly clamped in place. Otherwise the Deflection Yoke may shift its position and cause a loss of convergence and purity.

4 Schematic Diagram

Important Safety Notice







Components identified by  mark have special characteristics important for safety. When replacing any of these components, use only manufacturer's specified parts.

Notes :

1. Resistor

All resistors are carbon 1/4W resistors unless marked as follows :









Unit of resistance is OHM (Ω) (K = 1 000 M = 1 000 000)

	Nonflammable		Metal Oxide
	Solid		Metal Film
	Wire Wound		Fuse

2. Capacitor

All capacitors are ceramic 50V capacitors unless marked as follows :

Unit of capacitance is μF unless otherwise noted.

	Temperature Compensation		Electrolytic
	Polyester		Bipolar
	Metalized Polyester		Dipped Tantalum
	Polypropylene		Z-Type



3. Coil

Unit of inductance is μH , unless otherwise noted.

4. Test Point

 : Test Point position

5. Earth Symbol

 : Chassis Earth (Cold)  : Line Earth (Hot)

6. Voltage Measurement

Voltage is measured using DC voltmeter.

Conditions of the measurement are the following :

Power Source..... AC AUTO 110-240V, 50/60Hz

Receiving Signal.....Colour Bar signal (RF)

All customer's controls.....Maximum positions

7. Number in red circle indicates waveform number.

(See waveform pattern table.)

8. When arrow mark (↗) is found, connection is easily found from the direction of arrow.

9. → : Indicates the major signal flow.

10. This schematic diagram is the latest at the time of printing and subject to change without notice.

Remarks :

The Power Circuit contains a circuit area which uses a separate power supply to isolate the earth connection.

The circuit is defined by HOT and COLD indications in the schematic diagram.

Take the following precautions :

All circuits, except the Power Circuit are cold.

Precautions :

- a. Do not touch the hot part or the hot and cold parts at the same time or you may be shocked.
- b. Do not short-circuit the hot and cold circuits or a fuse may blow and parts may break.
- c. Do not connect an instrument such as an oscilloscope to the hot and cold circuits simultaneously or a fuse may be blown.
Connect the earth of instruments to the earth connection of the circuit being measured.
- d. Make sure to disconnect the power plug before removing the chassis.

4.1.2. A Board (2/5)

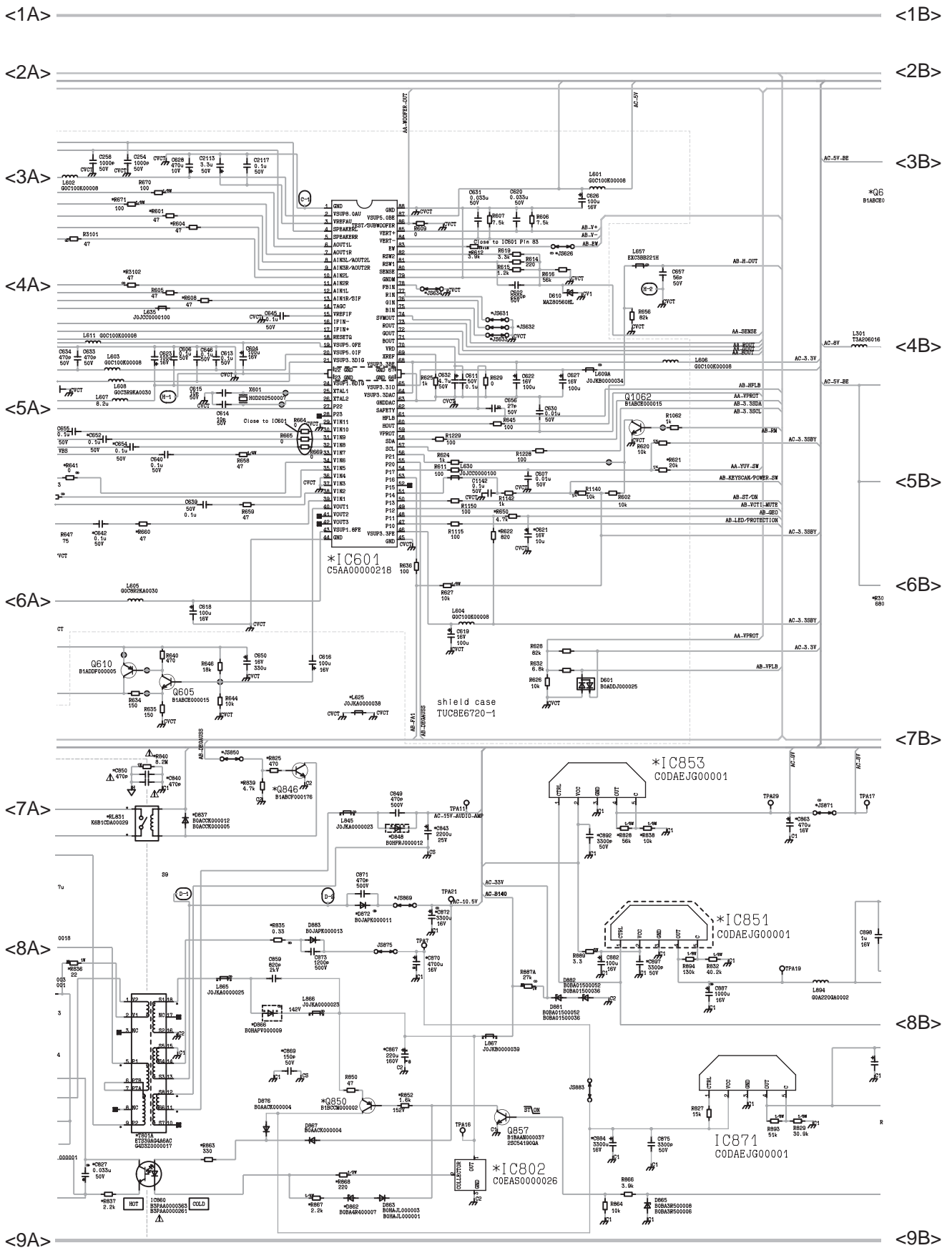

4.1.5. A Board (5/5)

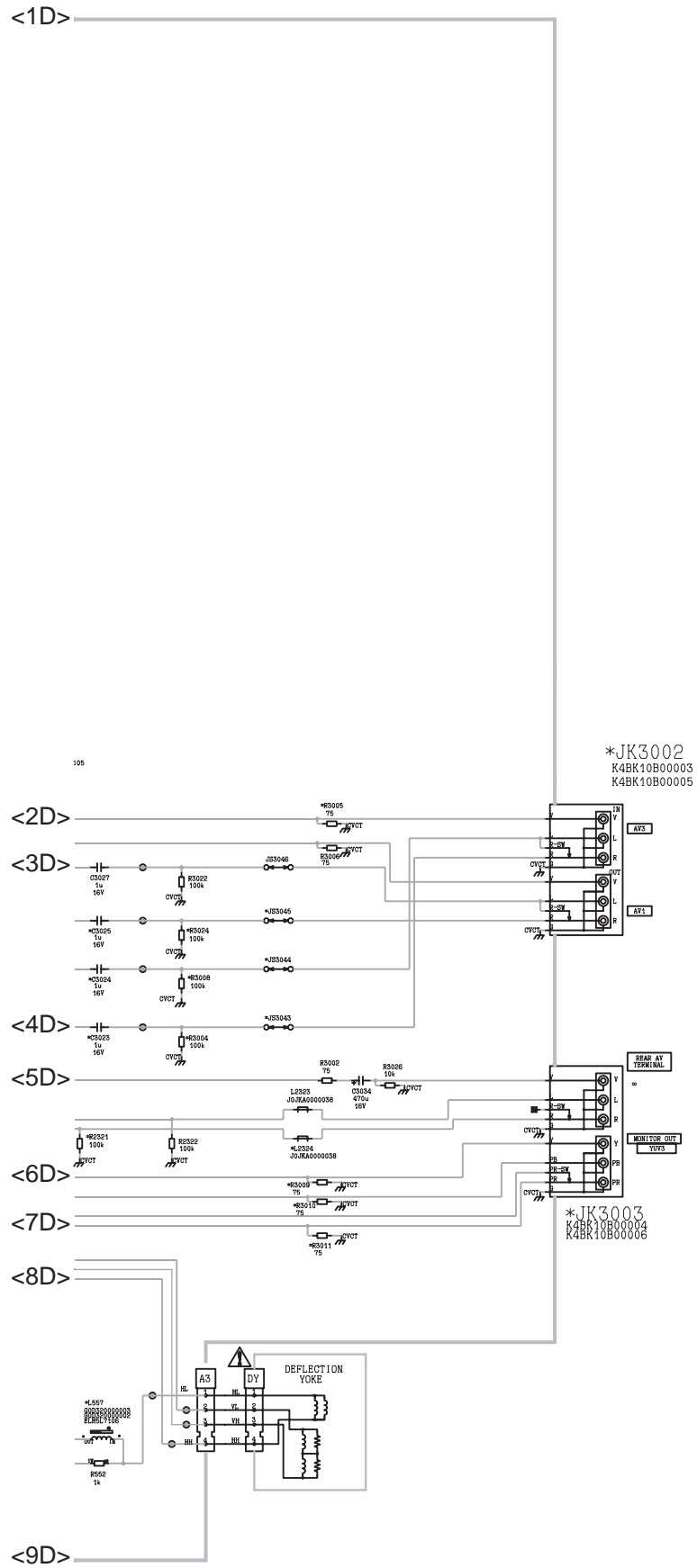

4.2. L Board

4.2.1. L Board (1/3)

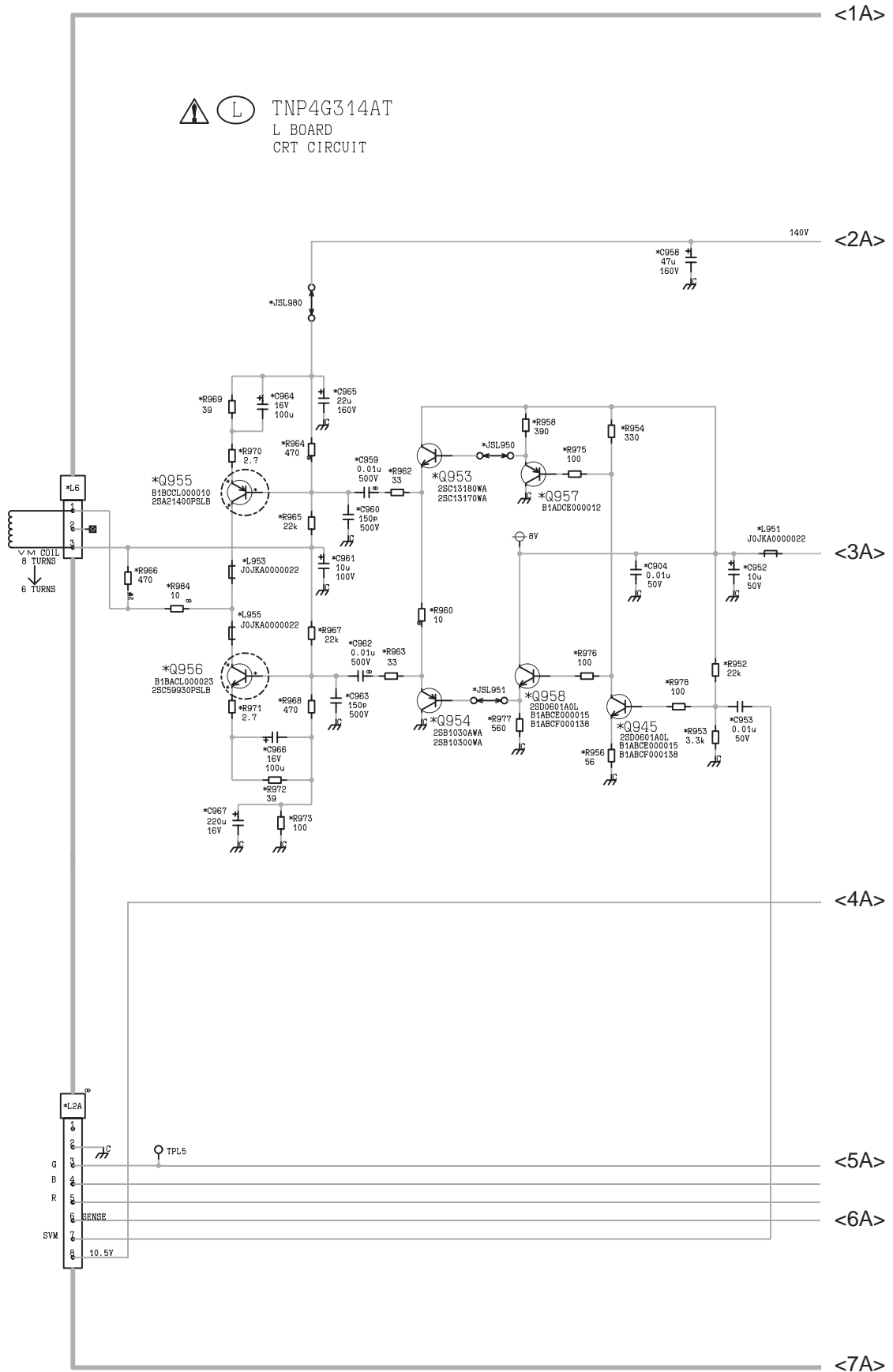

4.2.2. L Board (2/3)

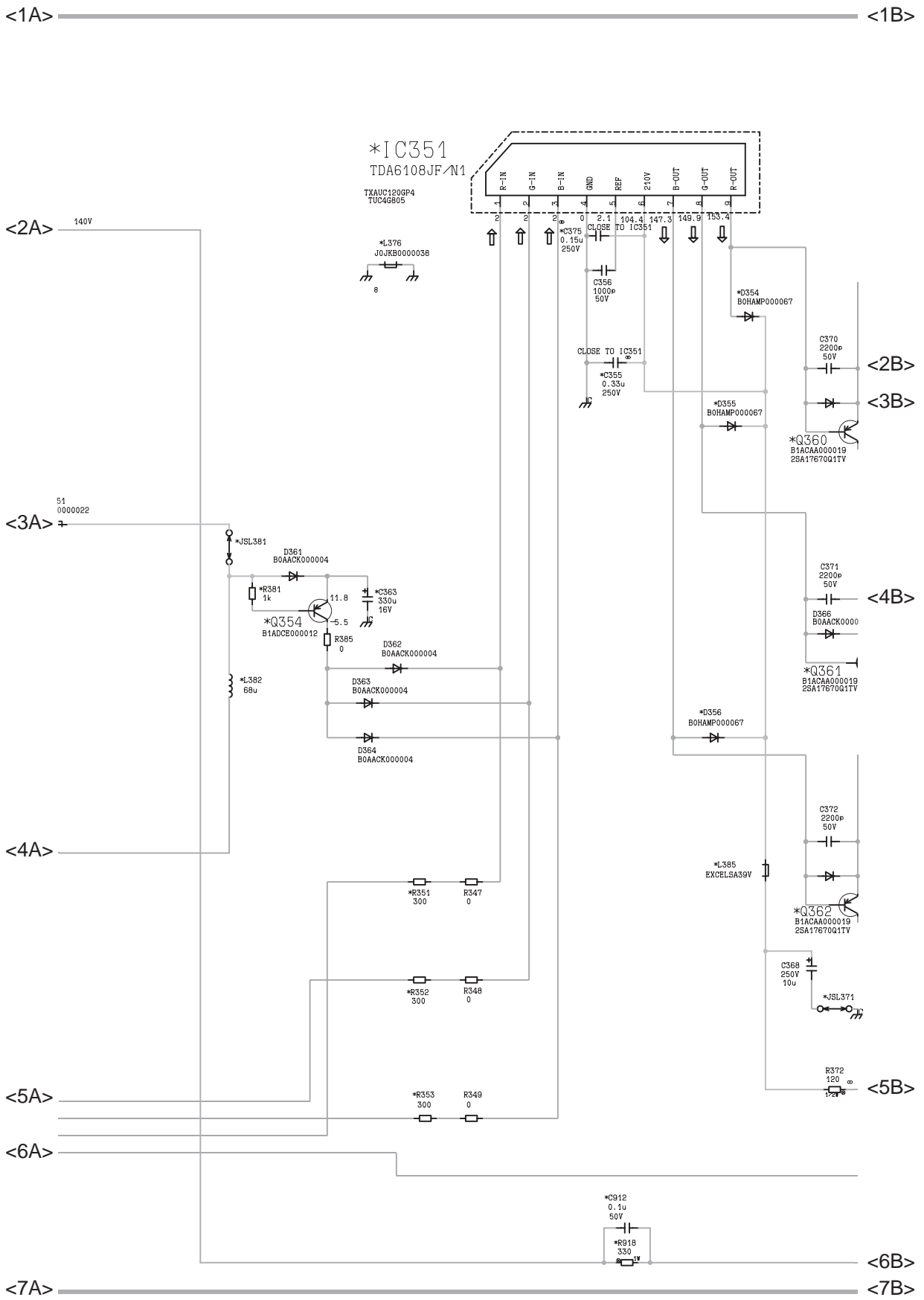

4.2.3. L Board (3/3)

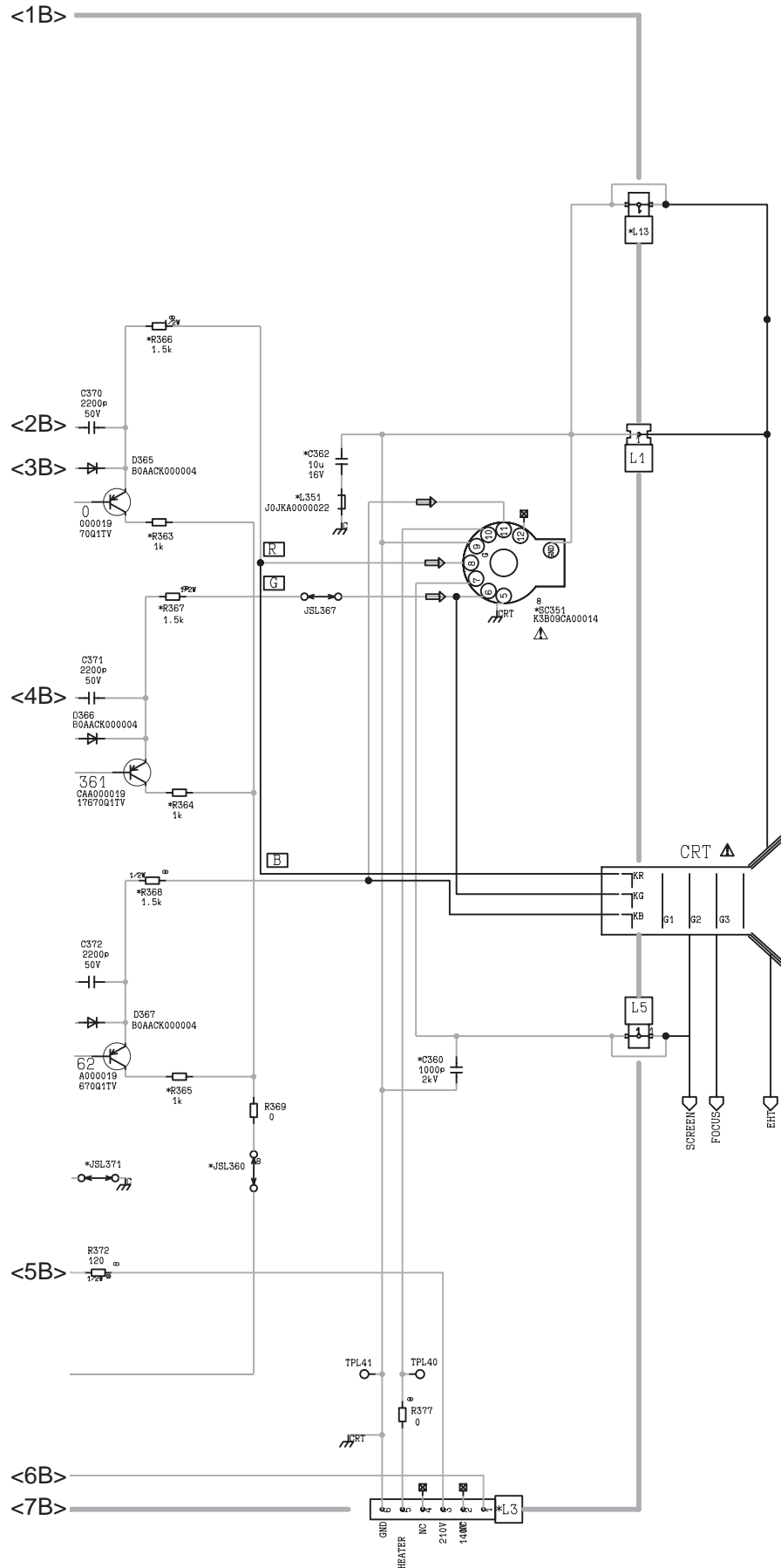

4.3. G Board

4.3.1. G Board (1/4)

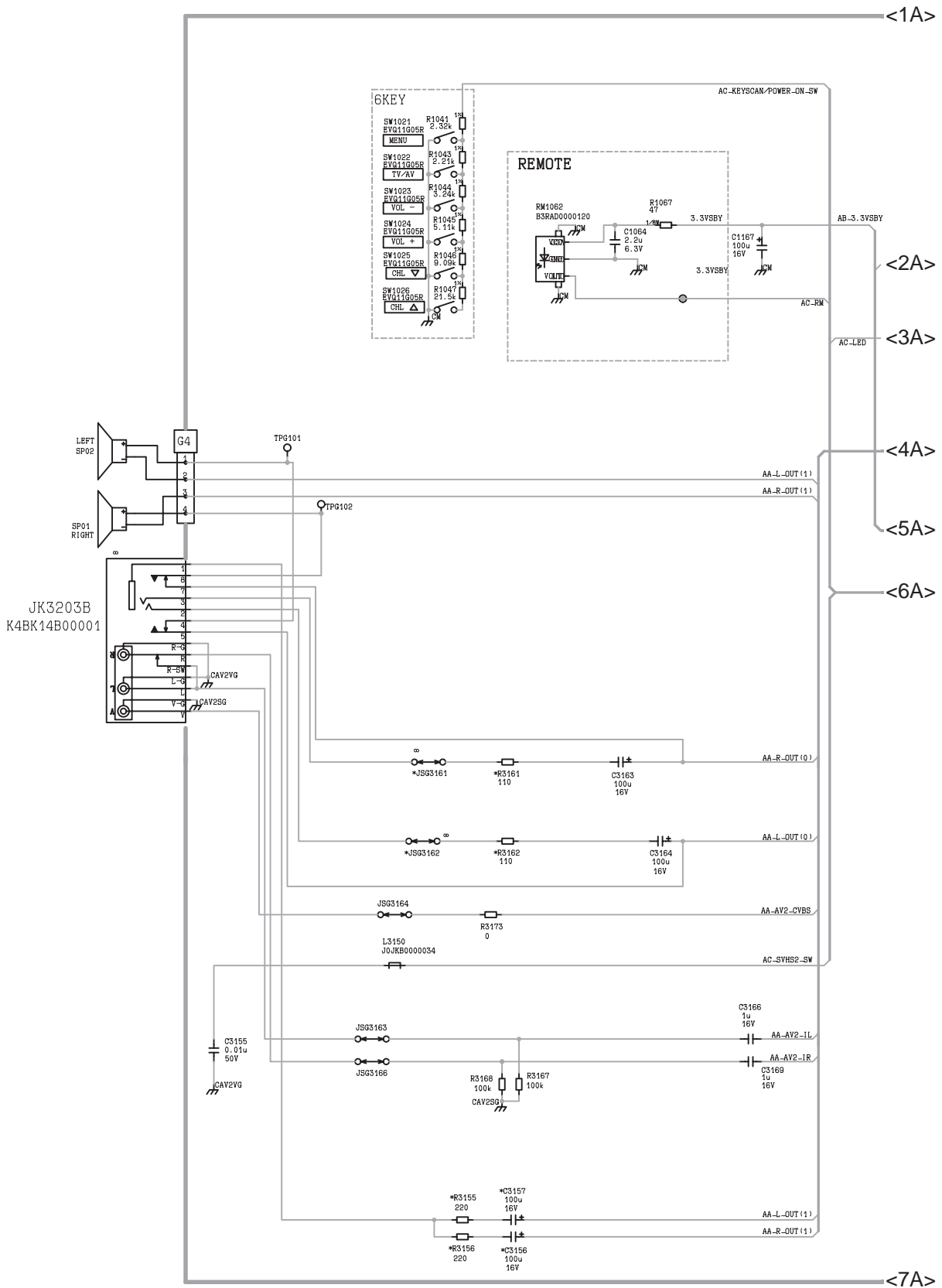

4.3.2. G Board (2/4)

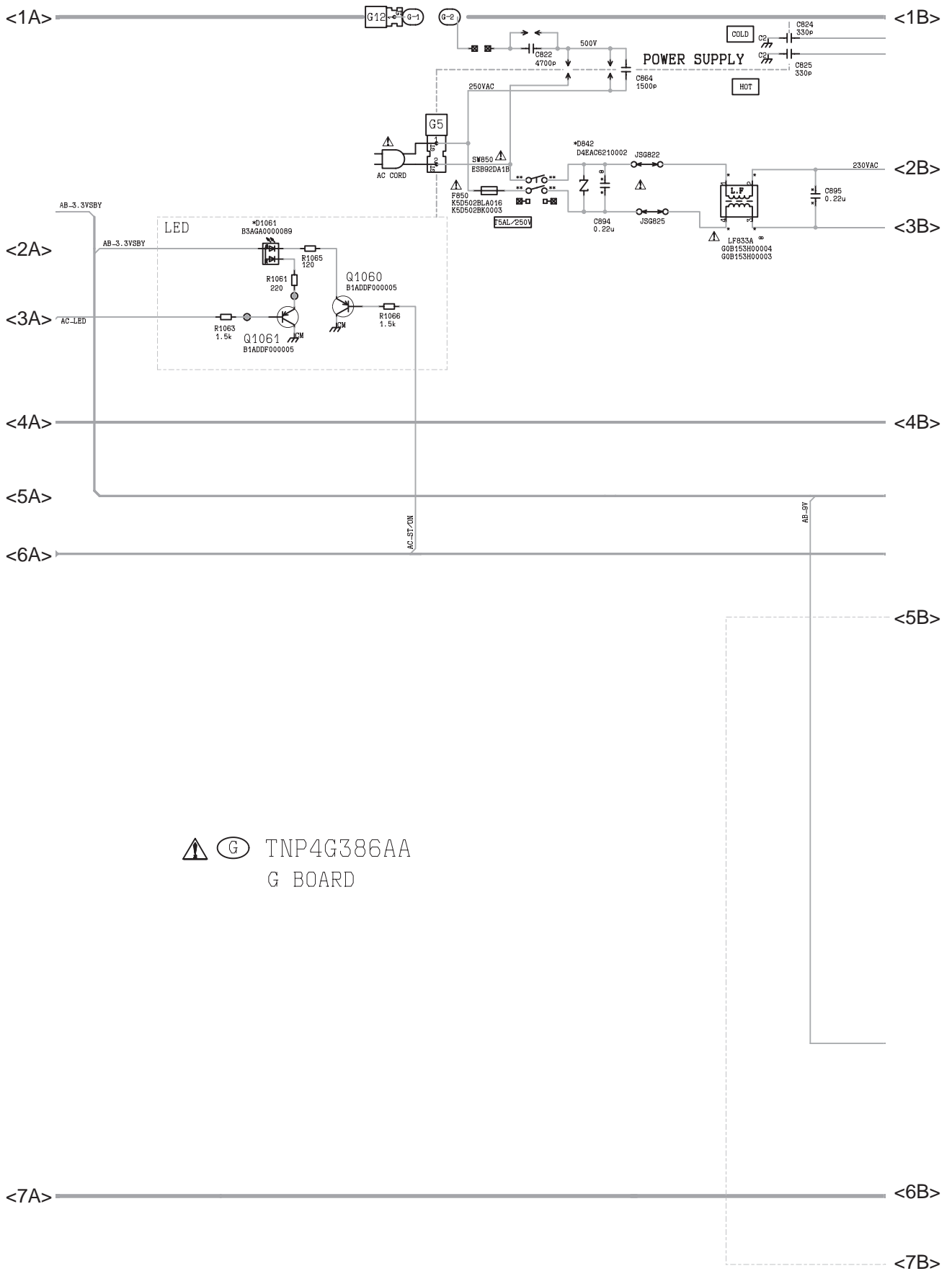

⚠ (G) TNP4G386AA
G BOARD

4.3.3. G Board (3/4)

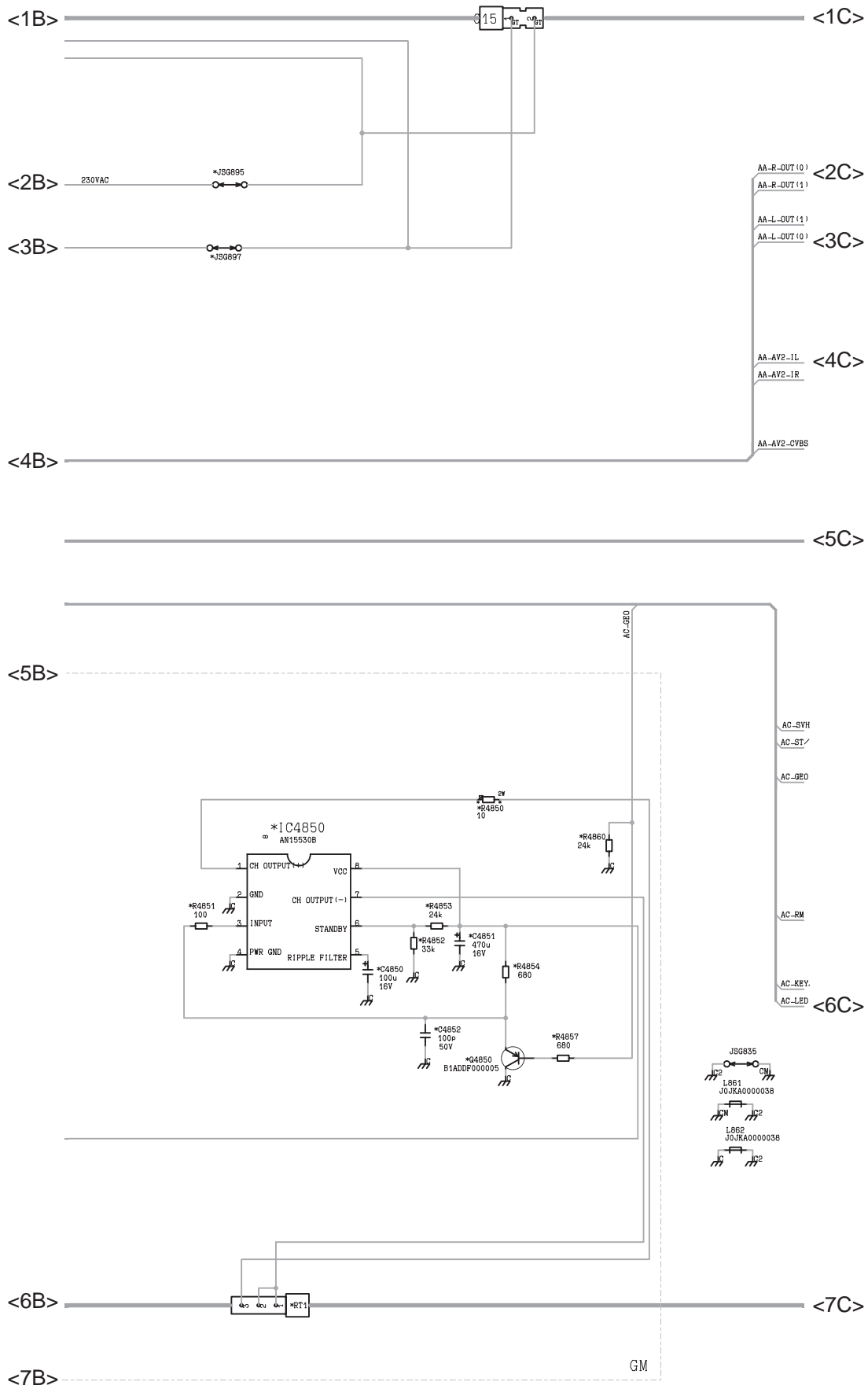

4.3.4. G Board (4/4)

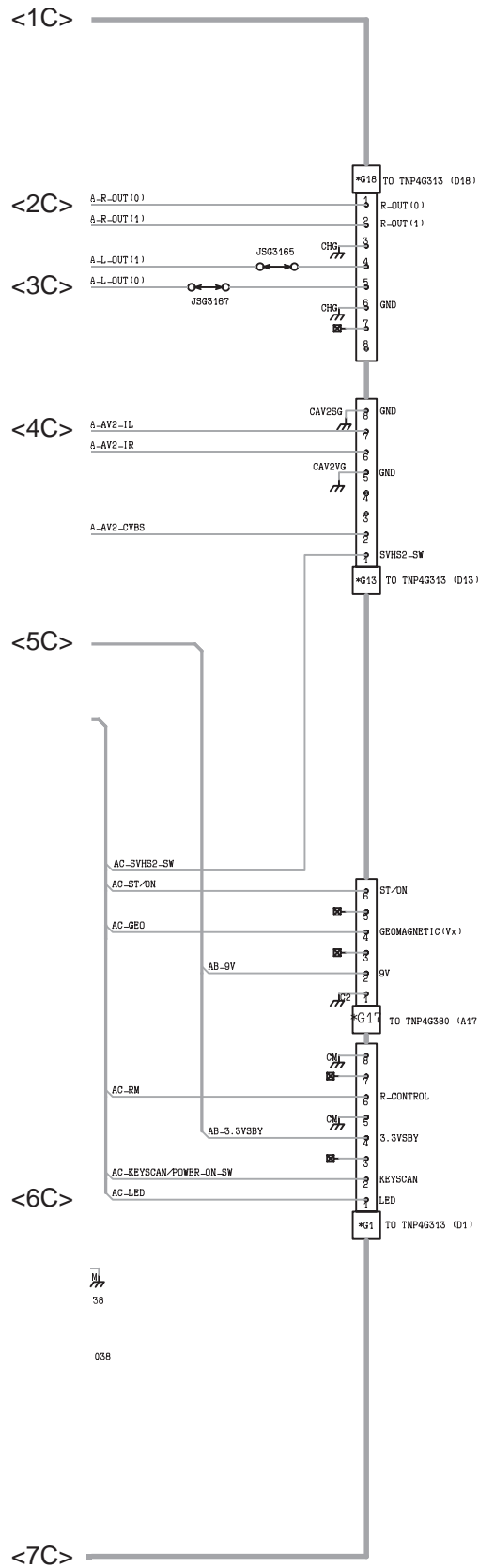

5 Parts Locations

PARTS LOCATION

Note: The number on mechanical parts indicates Ref. No. of Replacement Parts List.

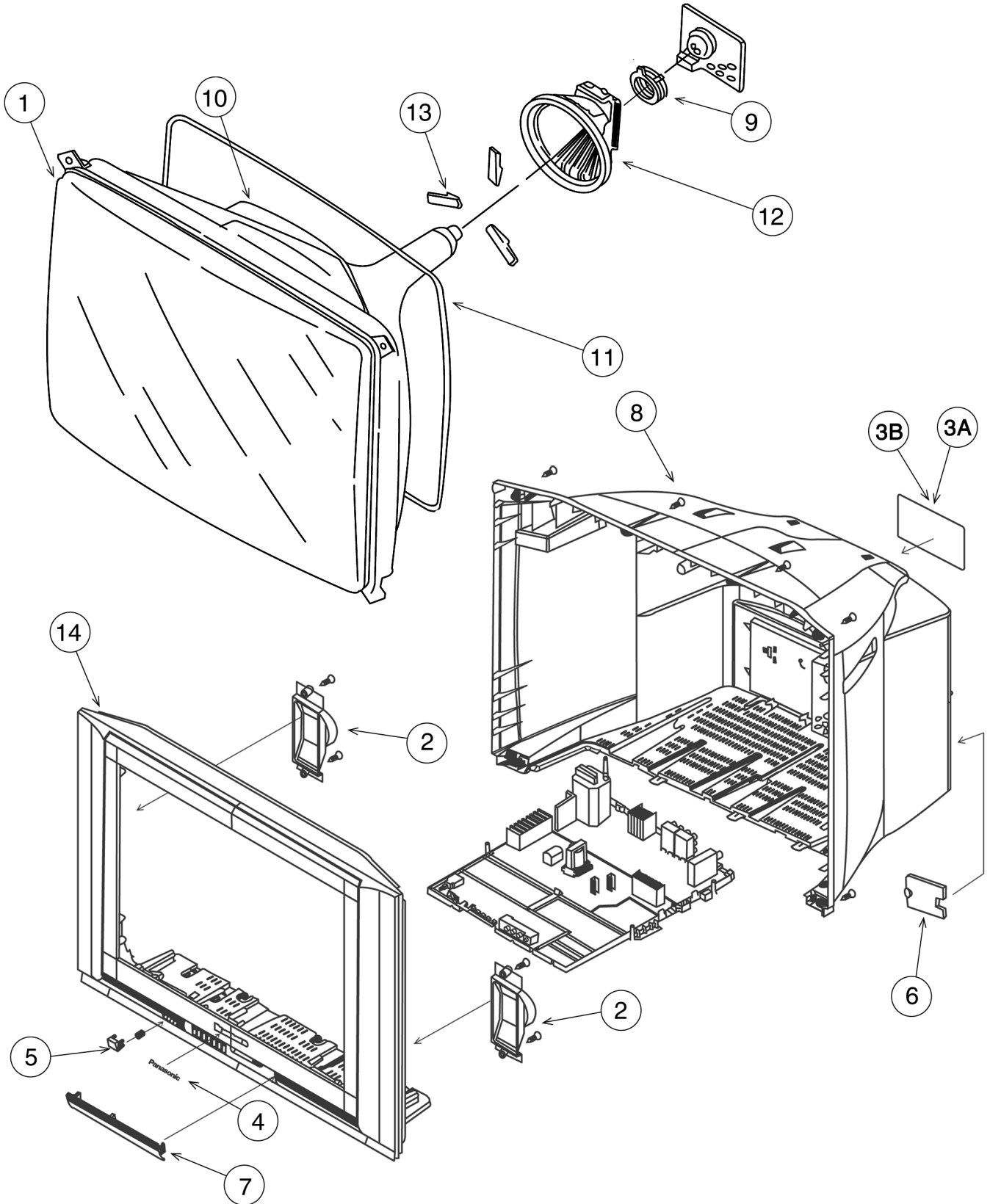

6 Replacement Parts List

Important Safety Notice

Components identified by  mark have special characteristics important for safety.
When replacing any of these components, use manufacturer's specified parts.

Note: Printed circuit board assembly with "NLA" is no longer available after production discontinuation of the complete set.

Abbreviation of part name and description

1. Resistor

Example :

ERD25TJ104 **C** 100K Ω , **J**, 1/4W
Type Allowance

Type	Allowance
C : Carbon	F : $\pm 1\%$
F : Fuse	G : $\pm 2\%$
M : Metal Oxide Metal Film	J : $\pm 5\%$ K : $\pm 10\%$
S : Solid	M : $\pm 20\%$
W : Wire Wound	

2. Capacitor

Example :

ECKF1H103ZF **C** 0.01 μ F, **Z**, 50V
Type Allowance

Type	Allowance
C : Carbon	C : $\pm 0.25\text{pF}$
E : Electrolytic	D : $\pm 0.5\text{pF}$
P : Polyester Polypropylene	F : $\pm 1\text{pF}$ G : $\pm 3\%$
T : Tantalum	J : $\pm 5\%$ K : $\pm 10\%$ L : $\pm 15\%$ M : $\pm 20\%$ P : $\pm 100\%$, -0% Z : $\pm 80\%$, -20%

6.1. Replacement Parts List

Ref. No.	Part No.	Part Name & Description	Remarks
1	A68LZU185X-E	PICTURE TUBE	△
2	EAS15S17A	SPEAKER	
	EUR7717040R	REMOTE CONTROL	
3A	TBM4G1320	MODEL NAME PLATE (KUWAIT ONLY)	△
3B	TBM4G1350	MODEL NAME PLATE (SAUDI / M' EAST ONLY)	△
4	TBM4G3017	PANASONIC BADGE	
5	TBX4G91111	POWER BUTTON	
	TES4G214	SPRING (POWER BUTTON)	
	TES4G406	COIL SPRING	
	TES4G409-1	SPRING (DOOR)	
	THT4G1011J	SCREW (SPEAKER)	
	THT4G10139	SCREW	
	TJS4G8160	AC PLUG ADAPTOR (KUWAIT ONLY)	△
6	TKP4G11744	AC CORD BRACKET	
7	TKP4G13461	DOOR	
8	TKU4GA1160	BACK COVER	
9	TLCA005	CONVERGENCE YOKE	
10	TLK4G9083X	ROTATION COIL	△
11	TLK4G9098X	DEGAUSSING COIL	△
12	TLY4G342T	DEFLECTION YOKE	△
13	TMM4G503	RUBBER WEDGE	
	TMM4G902-3	RUBBER WASHER	
NLA	TNP4G314AT	L BOARD	△
NLA	TNP4G380AD.B	A BOARD	△
NLA	TNP4G386AA	G BOARD	△
	TPE4G14038	SET COVER	
	TQB4G3982	FAN BAG (KUWAIT ONLY)	
	TQB4G5020	FAN BAG (SAUDI / M' EAST ONLY)	
	TSMA011	MAGNET	
	TSN63115-4	PURITY MAGNET	
	TSX4G194L-1	AC POWER CORD (KUWAIT ONLY)	△
	TSX4G189L-2	AC POWER CORD (SAUDI / M' EAST ONLY)	△
14	TXFKY01DS05	CABINET ASSY	
	TXFPC01DG08	CARTON	
	TXFPD01DG09	CUSHION (TOP)	
	TXFPD02DG09	CUSHION (BOTTOM)	
	CAPACITORS		
C002	ECJ2VF1H103Z	C 0.01UF, Z, 50V	
C003	ECJ2VC1H560J	C 56PF, J, 50V	
C004	ECJ2VC1H560J	C 56PF, J, 50V	
C006	F2A1C101A310	E 100UF, 16V	
C1064	ECJ2FB0J225K	C 2.2UF, J, 6.3V	
C1103	F1J1H103A590	C 0.01UF, J, 50V	
C1131	F1J1H103A590	C 0.01UF, J, 50V	
C1142	ECJ2VF1H104Z	C 0.1UF, Z, 50V	
C1167	ECA1CM101B	E 100UF, 16V	
C2113	F2A1H3R3A317	E 3.3UF, 50V	
C2117	ECJ2VF1H104Z	C 0.1UF, Z, 50V	
C2129	F2A1C102A159	E 1000UF, 16V	
C2303	F2A1H4R7A317	E 4.7UF, 50V	
C2314	F2A1E470A270	E 47UF, 25V	
C2315	ECA1EM471B	E 470UF, 25V	
C2321	F1J1H102A018	E 1000UF, 50V	
C2322	F1J1H102A018	E 1000UF, 50V	
C2325	F2A1C470A310	E 47UF, 16V	
C2326	F2A1C470A310	E 47UF, 16V	
C2328	F1J1E474A101	C 0.47UF, 25V	
C2329	F1J1E474A101	C 0.47UF, 25V	
C253	ECEA1HN2R2U	E 2.2UF, 50V	
C254	F1J1H102A018	E 1000UF, 50V	
C257	ECEA1HN2R2U	E 2.2UF, 50V	
C258	F1J1H102A018	E 1000UF, 50V	
C301	ECJ2VB1C104K	C 0.1UF, K, 16V	
C302	ECJ2VB1C104K	C 0.1UF, K, 16V	

Ref. No.	Part No.	Part Name & Description	Remarks
C3023	ECJ2VF1C105Z	C 1UF, Z, 16V	
C3024	ECJ2VF1C105Z	C 1UF, Z, 16V	
C3025	ECJ2VF1C105Z	C 1UF, Z, 16V	
C3027	ECJ2VF1C105Z	C 1UF, Z, 16V	
C303	ECJ2VB1C104K	C 0.1UF, K, 16V	
C3034	ECA1AM471B	E 470UF, 10V	
C305	F2A1C4710045	E 470UF, 16V	
C306	F1J1H102A018	E 1000UF, 50V	
C307	F1J1H102A018	E 1000UF, 50V	
C308	F1J1H102A018	E 1000UF, 50V	
C3155	F1J1H103A590	C 0.01UF, J, 50V	
C3156	ECA1CM101B	E 100UF, 16V	
C3157	ECA1CM101B	E 100UF, 16V	
C3163	F2A1C101A310	E 100UF, 16V	
C3164	F2A1C101A310	E 100UF, 16V	
C3166	ECJ2VF1C105Z	C 1UF, Z, 16V	
C3169	ECJ2VF1C105Z	C 1UF, Z, 16V	
C355	ECWF2334JSR	P 0.33UF, J, 250V	
C356	ECJ2VC1H102J	C 1000PF, J, 50V	
C360	ECKW3D102KBP	C 1000PF, K, 2KV	
C362	ECEA1CN100U	E 10UF, 16V	
C363	F2A1C331A159	E 330UF, 16V	
C368	ECA2EM100B	E 10UF, 250V	
C370	ECJ2VF1H222Z	C 2200PF, Z, 50V	
C371	ECJ2VF1H222Z	C 2200PF, Z, 50V	
C372	ECJ2VF1H222Z	C 2200PF, Z, 50V	
C375	ECWF2154JSR	P 0.15UF, J, 250V	
C401	ECJ2VC1H560J	C 56PF, J, 50V	
C404	ECQB1222JF	P 2200PF, J, 100V	
C406	F2A1H221A247	E 220UF, 50V	
C407	ECJ2VC1H560J	C 56PF, J, 50V	
C408	ECQB1154JF	P 0.15UF, J, 100V	
C454	ECQV1H154JM	P 0.15UF, J, 50V	
C4850	F2A1C101A310	E 100UF, 16V	
C4851	F2A1C471A339	E 470UF, 16V	
C4852	ECUX1H101JCX	C 100PF, J, 50V	
C502	ECKR3A821KBP	C 820PF, K, 1KV	
C504	F1J1H681A590	C 680PF, J, 50V	
C507	ECJ2VF1C105Z	C 1UF, Z, 16V	
C511	ECA1VM101B	E 100UF, 35V	
C512	F1B2H471A025	C 470PF, 500V	
C513	F1B2H331A025	C 330PF, 500V	
C514	F2A1E102A225	E 1000UF, 25V	
C515	F1B2H331A025	C 330PF, 500V	
C516	F2A1E102A225	E 1000UF, 25V	
C519	F2A2C2210013	E 220UF, 160V	
C520	F2A0J221A317	E 220UF, 6.3V	
C552	ECA2EM100B	E 10UF, 250V	
C553	F0C2E684A040	P 0.68UF, 250V	
C554	F0C2E684A040	P 0.68UF, 250V	
C555	ECWF2564JSB	P 0.56UF, 250V	
C559	ECWH20133JVVB	P 0.013UF, 2kV	
C560	ECQF4273JZH	P 0.027UF, 400V	
C561	ECWH20202JVY	P 2000PF, 2kV	
C565	ECQB1H273JF	P 0.027UF, J, 50V	
C566	ECQM4472JZ	P 4700PF, J, 400V	
C568	F0C3D102A003	P 1000PF, 2kV	
C601	F1J1H183A021	C 0.018UF, 50V	
C602	F1J1H222A590	C 2200PF, 50V	
C604	F2A1C101A310	E 100UF, 16V	
C606	ECJ2VF1H104Z	C 0.1UF, Z, 50V	
C607	ECJ2VF1H103Z	C 0.01UF, Z, 50V	
C611	ECJ2VF1H104Z	C 0.1UF, Z, 50V	
C613	ECJ2VF1H104Z	C 0.1UF, Z, 50V	
C614	ECJ2VC1H100C	C 10PF, C, 50V	
C615	ECJ2VC1H100C	C 10PF, C, 50V	
C616	F2A1C101A310	E 100UF, 16V	
C618	F2A1C101A310	E 100UF, 16V	
C619	F2A1C101A310	E 100UF, 16V	
C620	ECJ2VB1H333K	C 0.033UF, K, 50V	
C621	ECA1CM100B	E 10UF, 16V	
C622	F2A1C101A310	E 100UF, 16V	
C623	F2A1C101A310	E 100UF, 16V	

Ref. No.	Part No.	Part Name & Description	Remarks
C626	F2A1C101A310	E 100UF, 16V	
C627	F2A1C101A310	E 100UF, 16V	
C628	F2A1A471A274	E 470UF, 10V	
C630	ECJ2VF1H103Z	C 0.01UF, Z, 50V	
C631	ECJ2VB1H333K	C 0.033UF, K, 50V	
C632	F2A1H4R7A317	E 4.7UF, 50V	
C633	ECJ2VC1H471J	C 470PF, J, 50V	
C634	ECJ2VC1H471J	C 470PF, J, 50V	
C635	F2A1C101A310	E 100UF, 16V	
C639	ECJ2VF1H104Z	C 0.1UF, Z, 50V	
C640	ECJ2VF1H104Z	C 0.1UF, Z, 50V	
C642	ECJ2VF1H104Z	C 0.1UF, Z, 50V	
C645	ECJ2VF1H104Z	C 0.1UF, Z, 50V	
C646	ECJ2VF1H104Z	C 0.1UF, Z, 50V	
C650	ECA1CM331B	E 330UF, 16V	
C652	ECJ2VF1H104Z	C 0.1UF, Z, 50V	
C654	ECJ2VF1H104Z	C 0.1UF, Z, 50V	
C655	ECJ2VF1H104Z	C 0.1UF, Z, 50V	
C656	ECJ2VC1H270J	C 27PF, J, 50V	
C657	ECJ2VC1H560J	C 56PF, J, 50V	
C662	F2A0J101A317	E 100UF, 6.3V	
C704	F1B2H471A025	C 470PF, 500V	
C706	ECQM4222JZ	P 2200PF, 400V	
C818	ECQB1H104JF	P 0.1UF, 50V	△
C821	ECKW3D681KBP	C 680PF, K, 2KV	
C822	ECKCNA472ME7	C 4700PF, M,	
C824	F1A2E331A002	C 330PF, M,	
C825	F1A2E331A002	C 330PF, M,	
C826	ECQB1H103JF	P 0.01UF, 50V	
C827	ECQB1H333JF	P 0.033UF, J, 50V	
C840	ECKCNA471MB7	C 470PF, M,	
C841	ECKW3D151KBR	C 150PF, K, 2KV	
C842	F2A1H2200033	E 22UF, 50V	
C843	F2A1E222A224	E 2200UF, 25V	
C848	ECQB1H222JF	P 2200PF, J, 50V	
C849	F1B2H471A025	C 470PF, 500V	
C850	ECKCNA471MB7	C 470PF, M,	
C851	ECQB1H103JF	P 0.01UF, 50V	
C854	ECKWAE472ZED	C 4700PF, Z, 500V	
C855	ECKWAE472ZED	C 4700PF, Z, 500V	
C856	F2B2G4710006	E 470UF, 400V	
C857	ECQM4473JZ	P 0.047UF, J, 400V	
C859	ECKW3D821KBP	C 820PF, K, 2KV	
C863	F2A1C4710045	E 470UF, 16V	
C864	ECKCNA152ME7	C 1500PF, M,	
C865	ECKW3D331JBP	C 330PF, J, 2KV	
C867	F2A2C2210013	E 220UF, 160V	
C869	ECUX1H151JCX	C 150PF, J, 50V	
C870	F2A1C472A260	E 4700UF, 16V	
C871	F1B2H471A025	C 470PF, 500V	
C872	F2A1C332A260	E 3300UF, 16V	
C873	L6Y5P4B122K	C 1200PF, K, 500V	
C875	FLJ1H332A021	C 3300PF, 50V	
C877	F2A1C1000079	E 10UF, 16V	
C879	F2A0J331A260	E 330UF, 6.3V	
C882	F2A1C101A310	E 100UF, 16V	
C884	F2A1C332A182	E 3300UF, 16V	
C886	F2A1H330A342	E 33UF, 50V	
C887	F2A1C102A159	E 1000UF, 16V	
C891	F2A1C101A310	E 100UF, 16V	
C892	FLJ1H332A021	C 3300PF, 50V	
C893	ECA1CM221B	E 220UF, 16V	
C894	B81130C1224M	P 0.22UF, 275V	
C895	B81130C1224M	P 0.22UF, 275V	
C897	FLJ1H332A021	C 3300PF, 50V	
C898	ECJ2VF1C105Z	C 1UF, Z, 16V	
C904	F1B1H103A013	C 0.01UF, 50V	
C912	FLJ1H104A578	C 0.1UF, 50V	
C952	ECA1HHG100	E 10UF, 50V	
C953	F1B1H103A013	C 0.01UF, 50V	
C958	ECA2CM470B	E 47UF, 160V	
C959	F1B2H1030028	C 0.01UF, 500V	
C960	F1A2H151A035	C 150PF, 500V	

Ref. No.	Part No.	Part Name & Description	Remarks
C961	F2A2A1000016	C 10UF, 100V	
C962	F1B2H1030028	C 0.01UF, 500V	
C963	F1A2H151A035	C 150PF, 500V	
C964	ECA1CHG101	E 100UF, 16V	
C965	ECA2CM220B	E 22UF, 160V	
C966	ECA1CHG101	E 100UF, 16V	
C967	ECA1CM221B	E 220UF, 16V	
		DIODES	
D1061	B3AGA0000089	DIODE	
D1132	B0BA3R800012	DIODE	
D2103	B0AACK000004	DIODE	
D2107	B0AACK000004	DIODE	
D2108	B0AACK000004	DIODE	
D354	BOHAMP000067	DIODE	
D355	BOHAMP000067	DIODE	
D356	BOHAMP000067	DIODE	
D361	B0AACK000004	DIODE	
D362	B0AACK000004	DIODE	
D363	B0AACK000004	DIODE	
D364	B0AACK000004	DIODE	
D365	B0AACK000004	DIODE	
D366	B0AACK000004	DIODE	
D367	B0AACK000004	DIODE	
D402	BOHAJL000003	DIODE	
D503	B0AACK000004	DIODE	
D504	B0AACK000004	DIODE	
D507	BOACMJ000001	DIODE	
D511	MA4108J	DIODE	
D512	BOHAJL000003	DIODE	
D513	EU02	DIODE	
D515	EU02	DIODE	
D520	BOACDJ000009	DIODE	
D552	EU02	DIODE	
D556	BOHAMV000027	DIODE	
D557	BOHAMR000095	DIODE	
D558	MA185	DIODE	
D601	BOADDJ000025	DIODE	
D610	MAZ80560HL	DIODE	
D702	BOACMJ000001	DIODE	
D708	EU02	DIODE	
D830	BOHAJL000001	DIODE	
D831	B0BA01700055	DIODE	
D837	BOACCK000012	DIODE	
D842	D4EAC6210002	VARISTOR	
D846	B0BA01800037	ZENER DIODE	
D847	B0BA8R000010	DIODE	
D848	FMLG12S	DIODE	
D851	B0EART000018	DIODE	
D852	BOHAJL000003	DIODE	
D853	B0AACK000004	DIODE	
D854	B0AACK000004	DIODE	
D860	B0EBNT000007	DIODE	
D862	B0BA4R400007	ZENER DIODE	
D863	BOHAJL000003	DIODE	
D865	B0BA3R500008	DIODE	
D866	BOHAPV000009	DIODE	
D867	B0AACK000004	DIODE	
D872	B0JAPK000011	DIODE	
D873	B0AACK000004	DIODE	
D876	B0AACK000004	DIODE	
D881	B0BA01500052	DIODE	
D882	B0BA01500052	DIODE	
D883	B0JAPK000013	DIODE	
D884	B0AACK000004	DIODE	
D887	B0AACK000004	DIODE	
		INTEGRATED CIRCUITS	
IC1101	TVR4GAS492	EEPROM IC	
IC2301	COZAZ0000164	IC	
IC351	TDA6108JF/N1	IC	
IC451	AN15526A	IC	
IC4850	AN15530B	IC	
IC601	TVR4G19-5	FLASH MEMORY IC	

Ref. No.	Part No.	Part Name & Description	Remarks
IC605	COZAZ0000162	IC	
IC801	C5HABZZ00168	IC, POWER SUPPLY	△
IC802	COEAS0000026	IC	
IC851	C0DAEJG00001	IC, POWER SUPPLY	
IC853	C0DAEJG00001	IC, POWER SUPPLY	
IC857	C0DBEHE00005	IC, POWER SUPPLY	
IC860	B3PAA0000363	PHOTO COUPLER	△
IC871	C0DAEJG00001	IC, POWER SUPPLY	
IC875	C0DBEHE00005	IC, POWER SUPPLY	
	COILS		
L002	G0C100K00008	COIL	
L003	G0C4R7JA0055	PEAKING COIL	
L2302	J0JKA0000038	BEAD CORE	
L2304	J0JKA0000038	BEAD CORE	
L2306	J0JKA0000024	EMI FILTER	
L2307	J0JKA0000038	BEAD CORE	
L2323	J0JKA0000038	BEAD CORE	
L2324	J0JKA0000038	BEAD CORE	
L3150	J0JKB0000034	EMI FILTER	
L351	J0JKA0000022	BEAD CORE	
L376	J0JKB0000038	COIL	
L382	TALL08T680KA	INDUCTION COIL	
L385	EXCELSA39V	BEAD CORE	
L412	J0JKA0000024	EMI FILTER	
L505	J0JKA0000024	EMI FILTER	
L550	J0JKB0000034	EMI FILTER	
L554	ELC08D682E	CHOKE COIL	
L557	G0D320000003	LINEARITY COIL	
L565	EXCELSA39V	BEAD CORE	
L566	G0B111F00001	CHOKE COIL	
L601	G0C100K00008	COIL	
L602	G0C100K00008	COIL	
L603	G0C100K00008	COIL	
L604	G0C100K00008	COIL	
L605	TALV35VB8R2K	PEAKING COIL	
L606	G0C100K00008	COIL	
L607	TALV35VB8R2K	PEAKING COIL	
L608	G0C3R9KA0030	PEAKING COIL	
L609	J0JKB0000034	EMI FILTER	
L611	G0C100K00008	COIL	
L625	J0JKA0000038	BEAD CORE	
L630	TSK1032	BEAD CORE	
L635	TSK1032	BEAD CORE	
L657	EXC3BB221H	CHIP BEAD CORE	
L705	ELC10D123E	CHOKE COIL	
L842	J0JKA0000025	BEAD CORE	
L843	J0JKA0000038	BEAD CORE	
L845	J0JKA0000023	BEAD CORE	
L861	J0JKA0000038	BEAD CORE	
L862	J0JKA0000038	BEAD CORE	
L865	J0JKA0000025	BEAD CORE	
L866	J0JKA0000023	BEAD CORE	
L867	J0JKB0000039	EMI FILTER	
L894	G0A220GA0002	CHOKE COIL	
L951	J0JKA0000022	BEAD CORE	
L953	J0JKA0000022	BEAD CORE	
L955	J0JKA0000022	BEAD CORE	
	TRANSISTORS		
Q1060	B1ADDF000005	TRANSISTOR	
Q1061	B1ADDF000005	TRANSISTOR	
Q1062	B1ABCE000015	TRANSISTOR	
Q2101	B1ADDF000005	TRANSISTOR	
Q301	B1GFCFAA0004	TRANSISTOR	
Q302	B1GFCFAA0004	TRANSISTOR	
Q303	B1GFCFAA0004	TRANSISTOR	
Q304	B1ADDF000005	TRANSISTOR	
Q305	B1ADDF000005	TRANSISTOR	
Q306	B1ADDF000005	TRANSISTOR	
Q354	B1ADCE000012	TRANSISTOR	
Q360	B1ACAA000019	TRANSISTOR	
Q361	B1ACAA000019	TRANSISTOR	
Q362	B1ACAA000019	TRANSISTOR	
Q4850	B1ADDF000005	TRANSISTOR	

Ref. No.	Part No.	Part Name & Description	Remarks
Q501	2SC4212H	TRANSISTOR	
Q520	B1ADBM000004	TRANSISTOR	
Q551	2SC6073000LK	TRANSISTOR	
Q601	B1ABCE000015	TRANSISTOR	
Q603	B1ABCE000015	TRANSISTOR	
Q604	B1ABCE000015	TRANSISTOR	
Q605	B1ABCE000015	TRANSISTOR	
Q608	B1ABCE000015	TRANSISTOR	
Q610	B1ADDF000005	TRANSISTOR	
Q701	B1MBDLB00002	TRANSISTOR	
Q702	B1ABCE000015	TRANSISTOR	
Q703	B1ABCE000015	TRANSISTOR	
Q846	B1ABCF000176	TRANSISTOR	
Q850	B1BCCM000002	TRANSISTOR	
Q857	B1BAAN000037	TRANSISTOR	
Q870	B1ADDF000005	TRANSISTOR	
Q945	2SD0601A0L	TRANSISTOR	
Q953	2SC1318	TRANSISTOR	
Q954	2SB1030A	TRANSISTOR	
Q955	B1BCCL000010	TRANSISTOR	
Q956	B1BACL000023	TRANSISTOR	
Q957	B1ADCE000012	TRANSISTOR	
Q958	2SD0601A0L	TRANSISTOR	
	RESISTORS		
R005	ERJ6GEYJ512	M 5.1KOHM,J,1/10W	
R006	ERJ6GEYJ473	M 47KOHM,J,1/10W	
R007	ERJ6GEYJ682	M 6.8KOHM,J,1/10W	
R1041	ERJ6ENF2321	F 2.32KOHM, 1/10W	
R1043	ERJ6ENF2211	F 2.21KOHM, 1/10W	
R1044	ERJ6ENF3241	M3.24KOHM, 1/10W	
R1045	ERJ6ENF5111	F 5.11KOHM, 1/10W	
R1046	ERJ6ENF9091	M9.09KOHM, 1/10W	
R1047	ERJ6ENF2152	M21.5KOHM, 1/10W	
R1061	ERJ6GEYJ221	M 220OHM,J,1/10W	
R1062	ERDS2TJ102	C 1KOHM,J, 1/4W	
R1063	ERJ6GEYJ152	M 1.5KOHM,J,1/10W	
R1065	ERJ6GEYJ121	M 120OHM,J,1/10W	
R1066	ERJ6GEYJ152	M 1.5KOHM,J,1/10W	
R1067	ERJ6GEYJ470	M 47OHM,J,1/10W	
R1105	ERJ6GEYJ103	M 10KOHM,J,1/10W	
R1106	ERJ6GEYJ102	M 1KOHM,J,1/10W	
R1108	ERJ6GEYJ101	M 100OHM,J,1/10W	
R1109	ERJ6GEYJ103	M 10KOHM,J,1/10W	
R1112	ERJ6GEYJ102	M 1KOHM,J,1/10W	
R1114	ERJ6GEYJ151	M 150OHM,J,1/10W	
R1115	ERJ6GEYJ101	M 100OHM,J,1/10W	
R1131	ERJ6GEYJ220	M 22OHM,J,1/10W	
R1132	ERJ6GEYJ220	M 22OHM,J,1/10W	
R1140	ER0S2CKF1002	M 10KOHM,F, 1/4W	
R1142	ERJ6ENF1001	M 1KOHM, 1/10W	
R1150	ERJ6GEYJ101	M 100OHM,J,1/10W	
R1201	ERJ6GEYJ102	M 1KOHM,J,1/10W	
R1202	ERJ6GEYJ102	M 1KOHM,J,1/10W	
R1228	ERJ6GEYJ101	M 100OHM,J,1/10W	
R1229	ERJ6GEYJ101	M 100OHM,J,1/10W	
R2112	ERJ6GEYJ102	M 1KOHM,J,1/10W	
R2114	ERJ6GEYJ104	M 100KOHM,J,1/10W	
R2317	ERJ6GEYJ622	M 6.2KOHM,J,1/10W	
R2318	D0AE1R0JA046	C 1OHM,J,1/10W	
R2319	D0AE1R0JA046	C 1OHM,J,1/10W	
R2321	ERJ6GEYJ104	M 100KOHM,J,1/10W	
R2322	ERJ6GEYJ104	M 100KOHM,J,1/10W	
R253	ERJ6GEYJ751	M 750OHM,J,1/10W	
R255	ERJ6GEYJ751	M 750OHM,J,1/10W	
R256	ERDS2TJ472	C 4.7KOHM,J, 1/4W	
R257	ERDS2TJ472	C 4.7KOHM,J, 1/4W	
R3002	ERJ6GEYJ750	M 75OHM, 1/10W	
R3004	ERJ6GEYJ104	M 100KOHM,J,1/10W	
R3005	ERJ6GEYJ750	M 75OHM, 1/10W	
R3006	ERJ6GEYJ750	M 75OHM, 1/10W	
R3008	ERJ6GEYJ104	M 100KOHM,J,1/10W	
R3009	ERJ6GEYJ750	M 75OHM, 1/10W	
R301	ERJ6GEYJ103	M 10KOHM,J,1/10W	

Ref. No.	Part No.	Part Name & Description	Remarks
R3010	ERJ6GEYJ750	M 750HM, 1/10W	
R3011	ERJ6GEYJ750	M 750HM, 1/10W	
R302	ERJ6GEYJ103	M 10KOHM,J,1/10W	
R3022	ERJ6GEYJ104	M 100KOHM,J,1/10W	
R3024	ERJ6GEYJ104	M 100KOHM,J,1/10W	
R3026	ERJ6GEYJ103	M 10KOHM,J,1/10W	
R303	ERJ6GEYJ103	M 10KOHM,J,1/10W	
R304	ERJ6GEYJ240	F 240HM,J, 1/10W	
R305	ERJ6GEYJ240	F 240HM,J, 1/10W	
R306	ERJ6GEYJ240	F 240HM,J, 1/10W	
R307	ERJ6GEYJ681	M 680OHM,J,1/10W	
R308	ERJ6GEYJ681	M 680OHM,J,1/10W	
R309	ERJ6GEYJ681	M 680OHM,J,1/10W	
R310	DOAE181JA046	C 180OHM,J, 1/10W	
R3101	ERDS2TJ470	C 470HM,J, 1/4W	
R3102	ERDS2TJ470	C 470HM,J, 1/4W	
R3104	ERJ6GEYOR00	M 0OHM,J,1/10W	
R3105	ERJ6GEYOR00	M 0OHM,J,1/10W	
R311	DOAE181JA046	C 180OHM,J, 1/10W	
R312	DOAE181JA046	C 180OHM,J, 1/10W	
R3155	ERJ6GEYJ221	M 220OHM,J,1/10W	
R3156	ERJ6GEYJ221	M 220OHM,J,1/10W	
R3161	ERJ6GEYJ111	F 110OHM,J, 1/10W	
R3162	ERJ6GEYJ111	F 110OHM,J, 1/10W	
R3167	ERJ6GEYJ104	M 100KOHM,J,1/10W	
R3168	ERJ6GEYJ104	M 100KOHM,J,1/10W	
R317	ERJ6GEYJ151	M 150OHM,J,1/10W	
R3173	ERJ6GEYOR00	M 0OHM,J,1/10W	
R318	ERJ6GEYJ151	M 150OHM,J,1/10W	
R319	ERJ6GEYJ151	M 150OHM,J,1/10W	
R347	ERJ6GEYOR00	M 0OHM,J,1/10W	
R348	ERJ6GEYOR00	M 0OHM,J,1/10W	
R349	ERJ6GEYOR00	M 0OHM,J,1/10W	
R351	ERJ6GEYJ301	M 300OHM,J,1/10W	
R352	ERJ6GEYJ301	M 300OHM,J,1/10W	
R353	ERJ6GEYJ301	M 300OHM,J,1/10W	
R363	ERJ6GEYJ102	M 1KOHM,J,1/10W	
R364	ERJ6GEYJ102	M 1KOHM,J,1/10W	
R365	ERJ6GEYJ102	M 1KOHM,J,1/10W	
R366	ERDS1TJ152	C 1.5KOHM,J, 1/2W	
R367	ERDS1TJ152	C 1.5KOHM,J, 1/2W	
R368	ERDS1TJ152	C 1.5KOHM,J, 1/2W	
R369	ERJ6GEYOR00	M 0OHM,J,1/10W	
R372	ERQ12AJ121P	F 120OHM,J, 1/2W	
R381	ERJ6GEYJ102	M 1KOHM,J,1/10W	
R385	ERJ6GEYOR00	M 0OHM,J,1/10W	
R401	ERDS2TJ104	C 100KOHM,J, 1/4W	
R403	ERJ6GEYJ563	M 56KOHM,J,1/10W	
R404	ERJ6GEYJ153	M 15KOHM,J,1/10W	
R405	ERDS2TJ563	C 56KOHM,J, 1/4W	
R406	ERDS1TJ1R5	C 1.5OHM,J, 1/2W	
R407	ERG1SJ221V	M 220OHM,J,1W	
R413	ERJ6GEYJ183	M 18KOHM,J,1/10W	
R416	ERX1SJR82E	M 0.82OHM,J,1W	
R451	ERJ6GEYJ223	M 22KOHM,J,1/10W	
R453	ERJ6GEYJ101	M 100OHM,J,1/10W	
R4850	ERG2FJ100H	M 100HM,J, 2W	
R4851	ERJ6GEYJ101	M 100OHM,J,1/10W	
R4852	ERJ6GEYJ333	M 33KOHM,J,1/10W	
R4853	ERJ6GEYJ243	M 24KOHM,J,1/10W	
R4854	ERJ6GEYJ681	M 680OHM,J,1/10W	
R4857	ERJ6GEYJ681	M 680OHM,J,1/10W	
R4860	ERJ6GEYJ243	M 24KOHM,J,1/10W	
R501	ERJ6GEYJ273	M 27KOHM,J,1/10W	
R502	ERJ6GEYJ103	M 10KOHM,J,1/10W	
R504	ERG2SJS332H	M 3.3KOHM,J, 2W	
R507	ERDS2TJ561	C 560OHM,J, 1/4W	
R508	ERG3FJ821H	M 820OHM,J, 3W	
R509	ERG3FJ122	M 1.2KOHM,J, 3W	
R511	ERJ6ENF1152	M11.5KOHM, 1/10W	
R512	ERJ6ENF1002	M 10KOHM, 1/10W	
R513	ERQ14AJ100E	F 100HM,J, 1/4W	
R516	ERX12SJR56P	M 0.56OHM, 1/2W	

Ref. No.	Part No.	Part Name & Description	Remarks
R517	ERX12SJR56P	M 0.56OHM, 1/2W	
R518	DODK3R3J0002	W 3.3OHM,J,1/10W	
R522	ERDS2TJ513	C 51KOHM,J, 1/4W	
R523	ERJ6GEYJ103	M 10KOHM,J,1/10W	
R524	ERJ6GEYJ104	M 100KOHM,J,1/10W	
R525	ERJ6GEYJ392	M 3.9KOHM,J,1/10W	
R551	ERGLFJ101P	M 100OHM,J,1/10W	
R552	ERGLS102P	M 1KOHM,J, 1W	
R553	ERJ6GEYJ183	M 18KOHM,J,1/10W	
R559	ERQ1CJPLR0S	F 10HM,J, 1W	
R580	ERJ6GEYJ392	M 3.9KOHM,J,1/10W	
R601	ERJ6GEYJ470	M 470HM,J,1/10W	
R602	ERDS2TJ103	C 10KOHM,J, 1/4W	
R603	ERJ6GEYJ471	M 470OHM,J,1/10W	
R604	ERJ6GEYJ470	M 470HM,J,1/10W	
R605	ERJ6GEYJ470	M 470HM,J,1/10W	
R606	ERJ6GEYJ752	M 7.5KOHM,J,1/10W	
R607	ERJ6GEYJ752	M 7.5KOHM,J,1/10W	
R608	ERJ6GEYJ470	M 470HM,J,1/10W	
R609	ERJ6GEYOR00	M 0OHM,J,1/10W	
R610	ERJ6GEYJ101	M 100OHM,J,1/10W	
R611	ERJ6GEYJ101	M 100OHM,J,1/10W	
R612	ERJ6GEYJ392	M 3.9KOHM,J,1/10W	
R613	ERJ6GEYJ102	M 1KOHM,J,1/10W	
R614	ERJ6GEYJ221	M 220OHM,J,1/10W	
R615	ERJ6GEYJ122	M 1.2KOHM,J,1/10W	
R616	ERJ6GEYJ563	M 56KOHM,J,1/10W	
R619	ERJ6GEYJ332	M 3.3KOHM,J,1/10W	
R620	ERJ6ENF1002	M 10KOHM, 1/10W	
R621	ERJ6ENF2002	M 20KOHM, 1/10W	
R622	ERJ6GEYJ821	M 820OHM,J,1/10W	
R624	ERJ6GEYJ102	M 1KOHM,J,1/10W	
R625	ERJ6GEYJ102	M 1KOHM,J,1/10W	
R626	ERJ6GEYJ103	M 10KOHM,J,1/10W	
R627	ERJ6GEYJ103	M 10KOHM,J,1/10W	
R628	ERJ6GEYJ823	M 82KOHM,J,1/10W	
R629	ERJ6GEYOR00	M 0OHM,J,1/10W	
R632	ERJ6GEYJ682	M 6.8KOHM,J,1/10W	
R634	ERJ6GEYJ151	M 150OHM,J,1/10W	
R635	ERJ6GEYJ151	M 150OHM,J,1/10W	
R636	ERJ6GEYJ101	M 100OHM,J,1/10W	
R638	ERJ6GEYOR00	M 0OHM,J,1/10W	
R640	ERJ6GEYJ471	M 470OHM,J,1/10W	
R641	ERJ6GEYOR00	M 0OHM,J,1/10W	
R643	ERJ6GEYOR00	M 0OHM,J,1/10W	
R644	ERJ6GEYJ103	M 10KOHM,J,1/10W	
R645	ERJ6GEYJ101	M 100OHM,J,1/10W	
R646	ERJ6GEYJ183	M 18KOHM,J,1/10W	
R647	ERJ6GEYJ750	M 750HM, 1/10W	
R650	ERJ6GEYJ472	M 4.7KOHM,J,1/10W	
R656	ERJ6GEYJ823	M 82KOHM,J,1/10W	
R658	ERDS2TJ470	C 470HM,J, 1/4W	
R659	ERJ6GEYJ470	M 470HM,J,1/10W	
R660	ERJ6GEYJ470	M 470HM,J,1/10W	
R664	ERDS2T0T	C 0OHM, 1/4W	
R665	ERDS2T0T	C 0OHM, 1/4W	
R669	ERDS2T0T	C 0OHM, 1/4W	
R670	ERJ6GEYJ101	M 100OHM,J,1/10W	
R671	ERJ6GEYJ101	M 100OHM,J,1/10W	
R701	ERJ6GEYJ103	M 10KOHM,J,1/10W	
R702	ERJ6GEYJ680	M 680HM,J,1/10W	
R703	ERJ6GEYJ103	M 10KOHM,J,1/10W	
R704	ERJ6GEYJ471	M 470OHM,J,1/10W	
R705	ERJ6GEYJ203	M 20KOHM,J,1/10W	
R713	ERG3SJS120H	M 120HM,J, 3W	
R715	ERDS2TJ433	C 43KOHM,J, 1/4W	
R825	ERJ6GEYJ471	M 470HM,J,1/10W	
R827	ERJ6GEYJ153	M 15KOHM,J,1/10W	
R828	ERJ6ENF5602	M 56KOHM, 1/10W	
R829	ERJ6ENF3092	F 30.9KOHM,J, 1/8W	△
R830	ERDS2TJ221	C 220OHM,J, 1/4W	
R831	ERDS2TJ682	C 6.8KOHM,J, 1/4W	
R832	ERJ6ENF4022	F 40.2KOHM, 1/8W	

Ref. No.	Part No.	Part Name & Description	Remarks
R833	D0AE432JA046	C 4.3KOHM,J, 1/4W	
R834	ERG2FJ104H	M 100KOHM,J, 2W	
R835	ERQ1CJPR33S	F 0.330HM,J, 1W	
R836	ERGLSJ220P	M 220HM,J, 1W	
R837	ERDS2TJ222	C 2.2KOHM,J, 1/4W	
R838	ERJ6ENF1002	M 10KOHM, 1/10W	
R839	ERJ6GEYJ472	M 4.7KOHM,J,1/10W	
R840	RCR100TAJ825	C 8.2MOHM,J, 1W	
R847	ER0S2CHF3652	M 36.5KOHM,J,1/10W	
R850	ERG3SJS470H	M 470HM,J,1/10W	
R852	D0AE162JA046	C 1.6KOHM,J, 1/10W	
R853	D0DM2R2KA001	W 2.20HM,J, 15W	△
R854	ERQ1ABJP470S	F 470HM,J, 1W	△
R856	ERG2SJS104H	M 100KOHM,J, 2W	
R863	ERDS2TJ331	C 330OHM,J, 1/4W	
R864	ERJ6GEYJ103	M 10KOHM,J,1/10W	
R866	ERJ6GEYJ392	M 3.9KOHM,J,1/10W	
R867	ERDS2TJ222	C 2.2KOHM,J, 1/4W	
R868	ERDS1TJ221	C 220OHM,J, 1/2W	
R871	ERJ6GEYJ103	M 10KOHM,J,1/10W	
R872	ERJ6ENF1052	F 10.5KOHM,J, 1W	
R873	ERJ6ENF1802	M 18KOHM, 1/10W	
R875	ERJ6GEYJ103	M 10KOHM,J,1/10W	
R876	ERJ6ENF1002	M 10KOHM, 1/10W	
R877	ERJ6ENF5101	F 5.1KOHM,J, 1W	
R882	ERJ6GEYJ332	M 3.3KOHM,J,1/10W	
R884	ERDS2TJ562	C 5.6KOHM,J, 1/4W	
R885	ERJ6GEYJ752	M 7.5KOHM,J,1/10W	
R886	ERJ6GEYJ433	M 43KOHM,J,1/10W	
R887	ERGLSJ273P	M 27KOHM,J, 1W	
R888	ERJ6GEYJ103	M 10KOHM,J,1/10W	
R889	ERX3FJ3R3H	M 3.30HM,J, 3W	
R893	ERJ6ENF5102	M 51KOHM, 1/10W	
R894	ERJ6ENF1303	M 130KOHM, 1/10W	
R918	ERQ1CJP331S	F 330OHM,J, 1W	
R952	ERJ6GEYJ223	M 22KOHM,J,1/10W	
R953	ERJ6GEYJ332	M 3.3KOHM,J,1/10W	
R954	ERJ6GEYJ331	M 330OHM,J,1/10W	
R956	ERJ6GEYJ560	M 560HM,J,1/10W	
R958	ERJ6GEYJ391	M 390OHM,J,1/10W	
R960	ERQ14AJ100E	F 100HM,J, 1/4W	
R962	ERJ6GEYJ330	M 330HM,J,1/10W	
R963	ERDS2TJ330	C 330HM,J, 1/4W	
R964	ERQ14AJ471E	F 470OHM,J, 1/4W	
R965	ERJ6GEYJ223	M 22KOHM,J,1/10W	
R966	ERG2SJ471E	M 470OHM,J, 2W	
R967	ERDS2TJ223	C 22KOHM,J, 1/4W	
R968	ERDS2TJ471	C 470OHM,J, 1/4W	
R969	ERDS2TJ390	C 390HM,J, 1/4W	
R970	ERDS2TJ2R7	C 2.70HM,J, 1/4W	
R971	ERDS2TJ2R7	C 2.70HM,J, 1/4W	
R972	ERDS2TJ390	C 390HM,J, 1/4W	
R973	ERDS2TJ101	C 100OHM,J, 1/4W	
R975	ERJ6GEYJ101	M 100OHM,J,1/10W	
R976	ERJ6GEYJ101	M 100OHM,J,1/10W	
R977	ERJ6GEYJ561	M 560OHM,J,1/10W	
R978	ERJ6GEYJ101	M 100OHM,J,1/10W	
R984	ERC14GK100	S 100HM,J,1/10W	
	TRANSFORMERS		
T551	ZTFP14504A	FLYBACK TRANS	△
T553	ETH19Y210BZ	H DRIVE TRANS	△
T801	ETS39AG4A6AC	SWITCHING TRANS	△
	OTHERS		
A1	K1KA13A00140	CONNECTOR	
A13	K1KA13A00140	CONNECTOR	
A17	K1KA13A00138	CONNECTOR	
A18	K1KA13A00140	CONNECTOR	
A2	K1KA13A00140	CONNECTOR	
A6	K1KA13A00138	CONNECTOR	
A8	K1KA04AA0093	CONNECTOR	
CF835	D4DDE9R00002	POSISTOR	△
F850	K5D502BLA016	FUSE	△
G4	K1KA04AA0190	CONNECTOR	

Ref. No.	Part No.	Part Name & Description	Remarks
JA1	ERJ6GEY0R00	M 00HM,J,1/10W	
JA10	ERJ6GEY0R00	M 00HM,J,1/10W	
JA11	ERJ6GEY0R00	M 00HM,J,1/10W	
JA12	ERJ6GEY0R00	M 00HM,J,1/10W	
JA13	ERJ6GEY0R00	M 00HM,J,1/10W	
JA14	ERJ6GEY0R00	M 00HM,J,1/10W	
JA15	ERJ6GEY0R00	M 00HM,J,1/10W	
JA16	ERJ6GEY0R00	M 00HM,J,1/10W	
JA17	ERJ6GEY0R00	M 00HM,J,1/10W	
JA18	ERJ6GEY0R00	M 00HM,J,1/10W	
JA2	ERJ6GEY0R00	M 00HM,J,1/10W	
JA3	ERJ6GEY0R00	M 00HM,J,1/10W	
JA4	ERJ6GEY0R00	M 00HM,J,1/10W	
JA5	ERJ6GEY0R00	M 00HM,J,1/10W	
JA6	ERJ6GEY0R00	M 00HM,J,1/10W	
JA7	ERJ6GEY0R00	M 00HM,J,1/10W	
JA8	ERJ6GEY0R00	M 00HM,J,1/10W	
JA9	ERJ6GEY0R00	M 00HM,J,1/10W	
JK3002	K4BK10B00003	REAR AV TERMINAL	
JK3003	K4BK10B00004	REAR AV TERMINAL	
JK3203	K4BK14B00001	AV TERMINAL	
JS104	ERJ6GEY0R00	M 00HM,J,1/10W	
JS105	ERJ6GEY0R00	M 00HM,J,1/10W	
JS2315	ERJ6GEY0R00	M 00HM,J,1/10W	
JS3043	ERJ6GEY0R00	M 00HM,J,1/10W	
JS3044	ERJ6GEY0R00	M 00HM,J,1/10W	
JS3045	ERJ6GEY0R00	M 00HM,J,1/10W	
JS3046	ERJ6GEY0R00	M 00HM,J,1/10W	
JS631	ERJ6GEY0R00	M 00HM,J,1/10W	
JS632	ERJ6GEY0R00	M 00HM,J,1/10W	
JS633	ERJ6GEY0R00	M 00HM,J,1/10W	
JS634	ERJ6GEY0R00	M 00HM,J,1/10W	
JS850	ERJ6GEY0R00	M 00HM,J,1/10W	
JSG3161	ERJ6GEYJ111	FIXED RESISTOR	
JSG3162	ERJ6GEYJ111	FIXED RESISTOR	
JSG3163	ERJ6GEY0R00	M 00HM,J,1/10W	
JSG3164	ERJ6GEY0R00	M 00HM,J,1/10W	
JSG3165	ERJ6GEY0R00	M 00HM,J,1/10W	
JSG3166	ERJ6GEY0R00	M 00HM,J,1/10W	
JSG3167	ERJ6GEY0R00	M 00HM,J,1/10W	
JSG835	ERJ6GEY0R00	M 00HM,J,1/10W	
L5	K1ZZ00001301	CONNECTOR	
L6	K1KA03AA0190	CONNECTOR	
L13	K1ZZ00001300	CONNECTOR	
LF833	G0B153H00004	LINE FILTER	
RL831	K6B1CDA00029	RELAY	△
RML062	B3RAD0000120	REMOCON RECEIVER	
RT1	K1KA03AA0190	CONNECTOR	
SC351	K3B09CA00014	CRT SOCKET	△
SW1021	EVQ11G05R	SWITCH	
SW1022	EVQ11G05R	SWITCH	
SW1023	EVQ11G05R	SWITCH	
SW1024	EVQ11G05R	SWITCH	
SW1025	EVQ11G05R	SWITCH	
SW1026	EVQ11G05R	SWITCH	
SW850	ESB92DA1B	SWITCH	△
TU001	ENV59K15G3F	TUNER	△
X601	H0D202500007	CRYSTAL OSC	
XF101	J0C3525A0002	DELAY LINE	△