

Service Manual

T-1 Trunk Card

KX-TDA0187

(for U.S.A.)

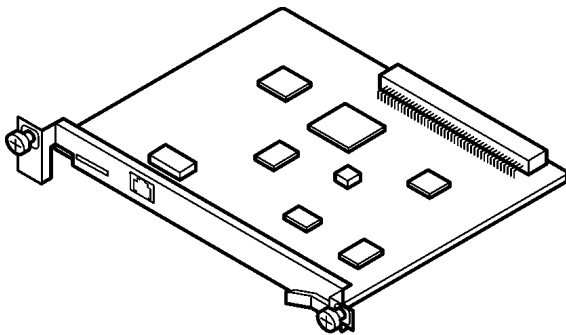

⚠ WARNING

This service information is designed for experienced repair technicians only and is not designed for use by the general public. It does not contain warnings or cautions to advise non-technical individuals of potential dangers in attempting to service a product. Products powered by electricity should be serviced or repaired only by experienced professional technicians. Any attempt to service or repair the product or products dealt with in this service information by anyone else could result in serious injury or death.

When you note the serial number, write down all of the 11 digits. The serial number may be found on the unit.

IMPORTANT INFORMATION ABOUT LEAD FREE, (PbF), SOLDERING

If lead free solder was used in the manufacture of this product the printed circuit boards will be marked PbF, Standard laded, (Pb), solder can be used as usual on boards without the PbF mark.

When this mark does appear please read and follow the special instructions described in this manual on the use of PbF and how it might be permissible to use Pb solder during service and repair work.

Panasonic

© 2003 Panasonic Communications Co., Ltd. All rights reserved. Unauthorized copying and distribution is a violation of law.

CONTENTS

	Page		Page
1 ABOUT LEAD FREE SOLDER (PbF: Pb Free)	3	9 HOW TO REPLACE A FLAT PACKAGE IC	32
1.1. SUGGESTED PBF SOLDER	3	9.1. PREPARATION	32
1.2. HOW TO RECOGNIZE THAT Pb FREE SOLDER IS USED	4	9.2. PROCEDURE	32
2 FOR SERVICE TECHNICIANS	4	9.3. REMOVING SOLDER FROM BETWEEN PINS	32
3 SPECIFICATIONS	5	10 TERMINAL GUIDE OF ICS, TRANSISTORS AND DIODES	33
4 NAMES AND LOCATIONS	6	11 CABINET AND ELECTRICAL PARTS LOCATION	34
4.1. INSTALLING/REMOVING THE OPTIONAL SERVICE CARDS	7	12 ACCESSORIES AND PACKING MATERIALS	35
5 TROUBLESHOOTING GUIDE	12	13 REPLACEMENT PARTS LIST	36
6 BLOCK DIAGRAM	17	13.1. CABINET AND ELECTRICAL PARTS LOCATION	36
7 CIRCUIT OPERATION	18	13.2. ACCESSORIES AND PACKING MATERIALS	36
7.1. CPU PERIPHERAL FUNCTION	18	13.3. MAIN BOARD PARTS	36
7.2. LINE INTERFACE FUNCTION	20	14 FOR SCHEMATIC DIAGRAM	41
7.3. DSP	21	15 SCHEMATIC DIAGRAM	42
7.4. LOCAL HIGHWAY INTERFACE FUNCTION	24	15.1. No.1	42
7.5. EC BUS INTERFACE	25	15.2. No.2	44
7.6. OUTLINE OF RESET SYSTEM	25	15.3. No.3	46
7.7. POWER SUPPLY	27	15.4. No.4	48
8 IC DATA	28	15.5. No.5	49
8.1. IC1 (CPU)	28	16 PRINTED CIRCUIT BOARD	50
8.2. IC2 (ASIC)	30	16.1. COMPONENT VIEW	50
		16.2. BOTTOM VIEW	51

1 ABOUT LEAD FREE SOLDER (PbF: Pb Free)

Note:

In the information below, Pb, the symbol for lead in the periodic table of elements, will refer to standard solder or solder that contains lead.

We will use PbF solder when discussing the lead free solder used in our manufacturing process which is made from Tin, (Sn), Silver, (Ag), and Copper, (Cu).

This model, and others like it, manufactured using lead free solder will have PbF stamped on the PCB. For service and repair work we suggest using the same type of solder although, with some precautions, standard Pb solder can also be used.

Caution

- PbF solder has a melting point that is 50° ~ 70° F, (30° ~ 40°C) higher than Pb solder. Please use a soldering iron with temperature control and adjust it to 700° ± 20° F, (370° ± 10°C). In case of using high temperature soldering iron, please be careful not to heat too long.
- PbF solder will tend to splash if it is heated much higher than its melting point, approximately 1100°F, (600°C).
- If you must use Pb solder on a PCB manufactured using PbF solder, remove as much of the original PbF solder as possible and be sure that any remaining is melted prior to applying the Pb solder.
- When applying PbF solder to double layered boards, please check the component side for excess which may flow onto the opposite side (See figure, below).

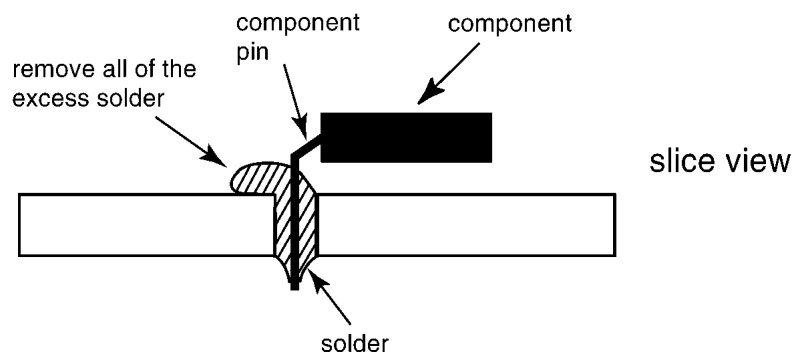

1.1. SUGGESTED PBF SOLDER

There are several types of PbF solder available commercially. While this product is manufactured using Tin, Silver, and Copper, (Sn+Ag+Cu), you can also use Tin and Copper, (Sn+Cu), or Tin, Zinc, and Bismuth, (Sn+Zn+Bi). Please check the manufacturer's specific instructions for the melting points of their products and any precautions for using their product with other materials. The following lead free (PbF) solder wire gauge are recommended for service of this product: 0.3mm, 0.6mm and 1.0mm.

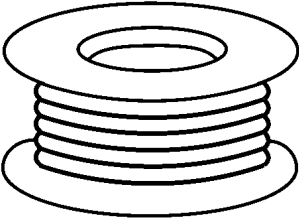
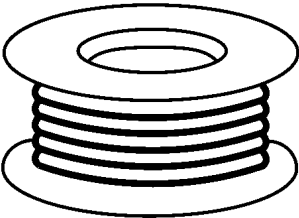
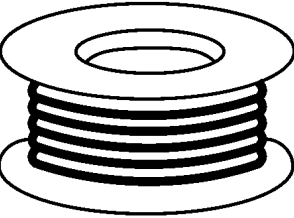
0.3mm X 100g	0.6mm X 100g	1.0mm X 100g
		

1.2. HOW TO RECOGNIZE THAT Pb FREE SOLDER IS USED

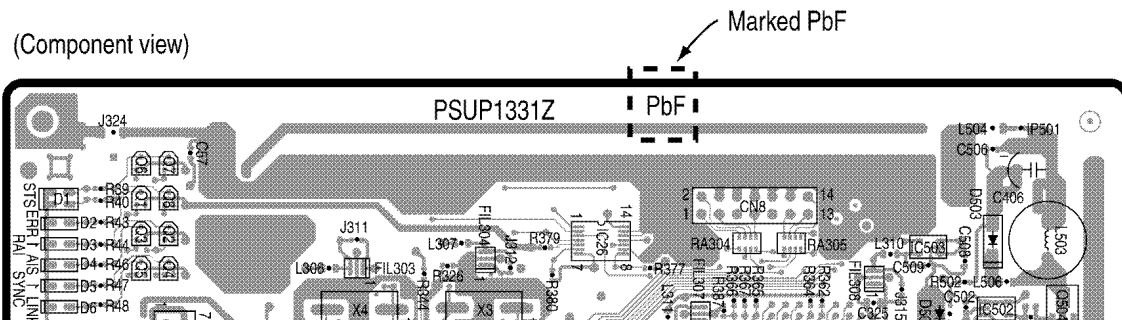

2 FOR SERVICE TECHNICIANS

ICs and LSIs are vulnerable to static electricity.

When repairing, the following precautions will help prevent recurring malfunctions.

1. Cover the plastic part's boxes with aluminum foil.
2. Ground the soldering irons.
3. Use a conductive mat on the worktable.
4. Do not touch the IC or LSI pins with bare fingers.

3 SPECIFICATIONS

Function Block	Function contents	
T1 Line Interface	Number of Ports	24 Ports
	Transfer Rate	1.544Mbit/s
	Line Code	B8ZS
	Framing	ESF(Extended Superframe) or D4/SF
	T1 Line Interface IC	MT9074 made by MITEL
	Line Interface Circuit (Except Interface IC)	Main Front End Circuit Pulse Transformer Surge Absorber EMC Filter
ASIC (IC2)	EC Bus Interface Functional (Slave) H.100 Bus Interface Functional, Digital PLL Function Local Bus Interface Functional (Compatible with legacy) Timing Switch Function, Gain Control Function, FIFO/DPRAM Function Returning Sound Function See the specification of eSAMSON for details.	
Controller	CPU	SH7020(12.288MHz)
	Flash	4Mbit(256K x 16) For software download
	SRAM	4Mbit(256K x 16)
DIMF Receiver/Generator	<p>In-band Signaling Function</p> <ul style="list-style-type: none"> • No. of Channels <ul style="list-style-type: none"> MFC-R1 Receiver : 30ch(Composed of DSP) MFC-R1 Generator : 30ch(Composed of DSP) DTMF Receiver : 24ch(Composed of DSP; DSP supports 30ch.) TMF Generator : Switch a signal from eMESSIAH on the MPR card. /DTMF Generator of DSP-30ch • Level <ul style="list-style-type: none"> MFC-R1 Output: Programmable and variable in the range of -31 to 0 dB. Detection: Programmable and variable in the range of -38 to 0dB. DTMF Output: Programmable and variable in the range of -12 to +3dB. Detection: Programmable and variable in the range of -42 to 0dB. 	
Gain Control Circuit	Use the gain control function in the eSAMSON Insert the loss of xxdB at the call on the internal line Insert the loss of 3dB at the call on the analog line Mu/A Conversion Function	
LED Display Circuit	Card State Display LED : 1 Line State Display LED : 4	
Line Interface Connector	For External	RJ45
	For Internal	RJ45
On-board DC/DC Power Supply	Input +15V Output +5V, +3.3V, +1.8V	
Self-diagnostic Functional	LSI Internal Loopback Test of T1 Line Interface Loopback Function by a relay on the primary side of the line	

4 NAMES AND LOCATIONS

Overview

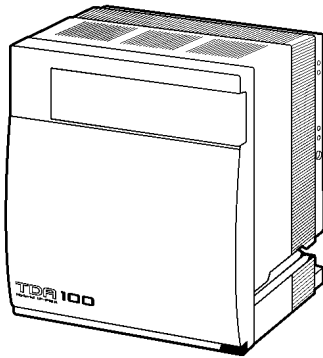

KX-TDA100

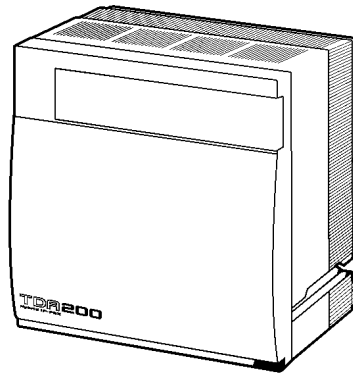

KX-TDA200

Inside View

KX-TDA100

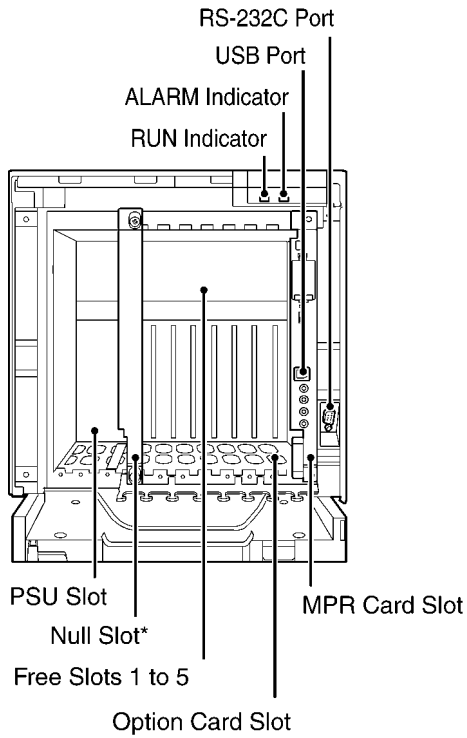

KX-TDA200

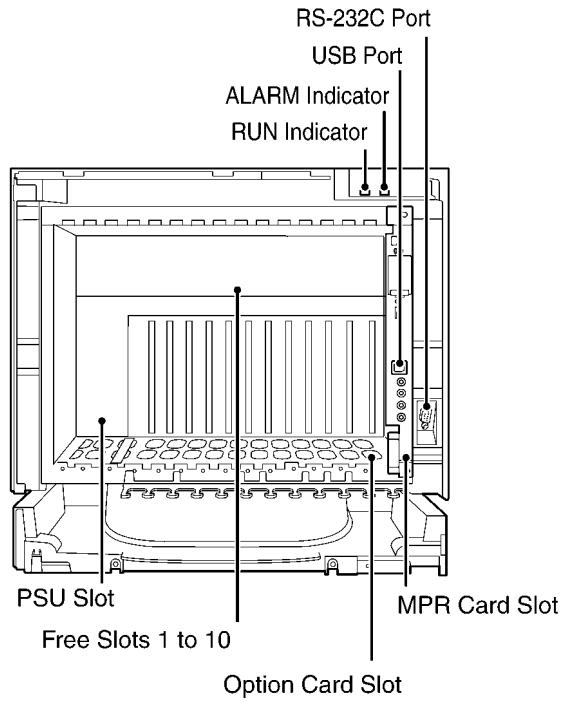

Note:

*Null slot is not available for any optional service cards.

4.1. INSTALLING/REMOVING THE OPTIONAL SERVICE CARDS

Slot Condition

Card Type	Slot Type		
	KX-TDA100:Free Slots 1 to 5 KX-TDA200:Free Slots 1 to 10	Option Slot	MPR Slot
MPR Card	No	No	Yes
CO Line Cards	Yes	No	No
Extension Cards	Yes	No	No
OPB3 Card	Yes	Yes	No
CTI-LINK Card	Yes	Yes	No

Caution:

To protect the back board from static electricity, do not touch parts on the back board in the main unit and on the optional service cards. To discharge static, touch ground or wear an earthing strap.

Function

1-port T1 CO line card. EIA/TIA standard compliant.

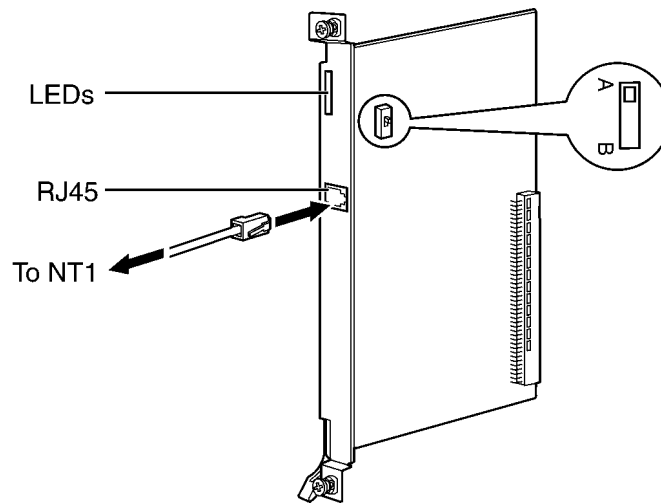

Accessory and User-supplied Items

Accessory (included): ferrite core x 1

User-supplied (not included): RJ45 connector

Notes

- Connect this optional service card to the CO line through NT1; do not connect to the CO line directly.
- T1 Card must be installed behind an FCC registered and UL or CSA-NRTL listed CSU.
- When connecting the RJ45 connector, attach the included ferrite core. Refer to "**Attaching a Ferrite Core to the RJ45 Cable**".
- To confirm the CO line connection, refer to "Confirming the CO Line Connection" in "**Starting the Hybrid IP-PBX**".

CAUTION

T1 ports are SELV ports and should only be connected to SELV services.

Switch Settings

Switch	Type	Usage and Status Definition
A/B	Slide	Keep the switch at default A position. Do not change the position of this switch.

Pin Assignments

RJ45 Connector

	No.	Signal Name	Level [V]	Function
	1	RX+	(+)	Receive data (+)
	2	RX-	(-)	Receive data (-)
	3	Reserved	-	-
	4	TX-	(-)	Transmit data (-)
	5	TX+	(+)	Transmit data (+)
	6-8	Reserved	-	-

LED Indications

Indication	Color	Description
CARD STATUS	Green/Red	OFF: Power Off Green ON: Normal (all ports are idle) Green Flash (60 times per minute): Normal (a port is in use) Red ON: Fault (includes reset) Red Flash (60 times per minute): Out of Service
SYNC-ERR	Red	OFF: Normal ON: Alarm
RAI	Red	OFF: Normal ON: Alarm (Clock Slave) Flash (60 times per minute): Alarm (Clock Master)
AIS	Red	OFF: Normal ON: Alarm
SYNC	Green	OFF: Alarm ON: Normal Flash (60 times per minute): Normal (Clock Master)

Starting the Hybrid IP-PBX

CAUTION

- SD Memory Card must be inserted in the SD Memory Card slot of the MPR card before start up.
- Before touching the System Clear Switch and the Reset Button, discharge static by touching ground or wearing a grounding strap.
- Once you have started the Hybrid IP-PBX and if you unplug the Hybrid IP-PBX, do not perform the following procedures to start the Hybrid IP-PBX again. Otherwise, your programmed data is cleared. To restart the Hybrid IP-PBX, refer to "Using the Reset Button".
- The Hybrid IP-PBX will continue to be powered even if the power switch is turned "OFF".
- The power supply cord is used as the main disconnect device, ensure that the socket-outlet is located/installed near the equipment and is easily accessible.

1. Set the System Clear Switch to the "SYSTEM INITIALIZE" position.

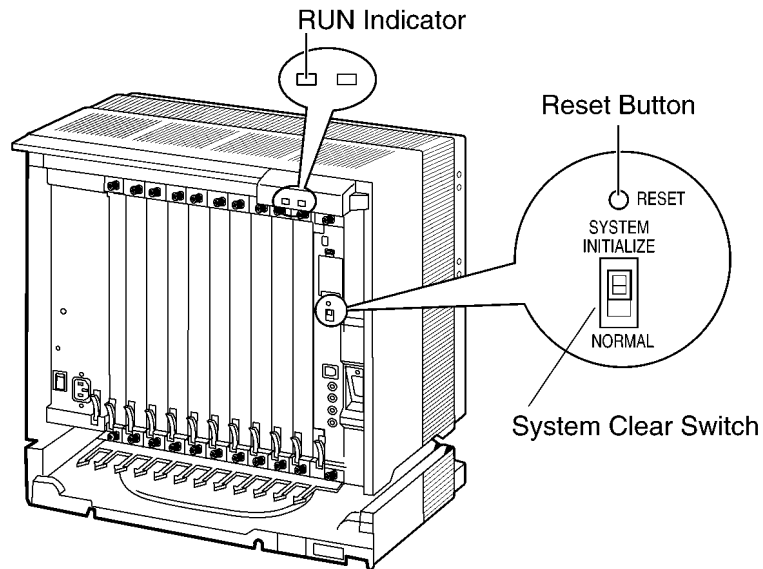

2. Plug the AC power cord into the Hybrid IP-PBX and an AC outlet, and turn on the Hybrid IP-PBX.

Note:

For safety reasons, do not stretch, bend, or pinch the AC power cord.

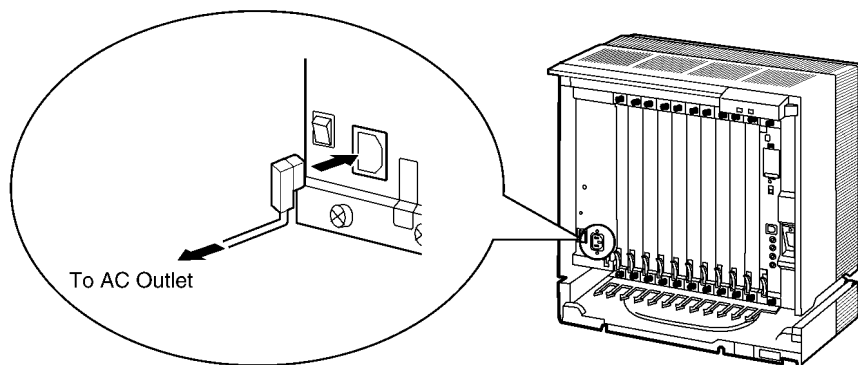

3. Press the Reset Button with a pointed tool. (The RUN indicator will flash.)
4. While the RUN indicator is flashing (within about 10 s), return the System Clear Switch to the "NORMAL" position. Depending on the configuration, initialization takes about 1 min to 3 min. If successfully executed, the RUN indicator will stop flashing and be kept lit.

All data will be cleared and the Hybrid IP-PBX will be initialized to the default values. The DPTs should show the time as 00:00.

Note:

Use the AC power cord attached to the PSU only.

LED Indications

Indication	Color	Description
RUN	Green	OFF: Power Off (includes normal reset)
		ON: Power On and running (on-line)
		Flash (60 times per minute): Power On and starting
		Flash (120 times per minute): Power On and resetting before system clear
ALARM	Red	OFF: Normal
		ON: Alarm (CPU stop, alarm for each card)
		Flash: Alarm (MPR file error in restarting)

Confirming the CO Line Connection

After initialization, program the Hybrid IP-PBX and establish CO line connection, and then use a PT to confirm it.

To confirm, dial [*] [3] [7] + CO line number (3 digits) or press S-CO button (CO01 to CO64). You will hear a dial tone if CO line is available and connected.

Using the Reset Button

If the Hybrid IP-PBX does not operate properly, use the Reset Button. Before using the Reset Button, try the system feature again to confirm whether there definitely is a problem or not.

Note:

1. When the System Clear Switch is set to "NORMAL", pressing the Reset Button causes the following:

- Camp-on is cleared.
- Calls on hold are terminated.
- Calls on exclusive hold are terminated.
- Calls in progress are terminated.
- Call park is cleared.

Other data stored in memory, except the above, are not cleared.

2. When the System Clear Switch is set to the "SYSTEM INITIALIZE" position, you must press the Reset Button with caution, because all data stored in memory will be cleared by the following operation: (1) pressing the Reset Button and then, (2) setting the System Clear Switch to the "NORMAL" position while the RUN indicator is flashing (within approximately 10 s).

Operation

1. If the Hybrid IP-PBX does not operate properly:

- a. Make sure that the System Clear Switch is set to the "NORMAL" position.
- b. Press the Reset Button.

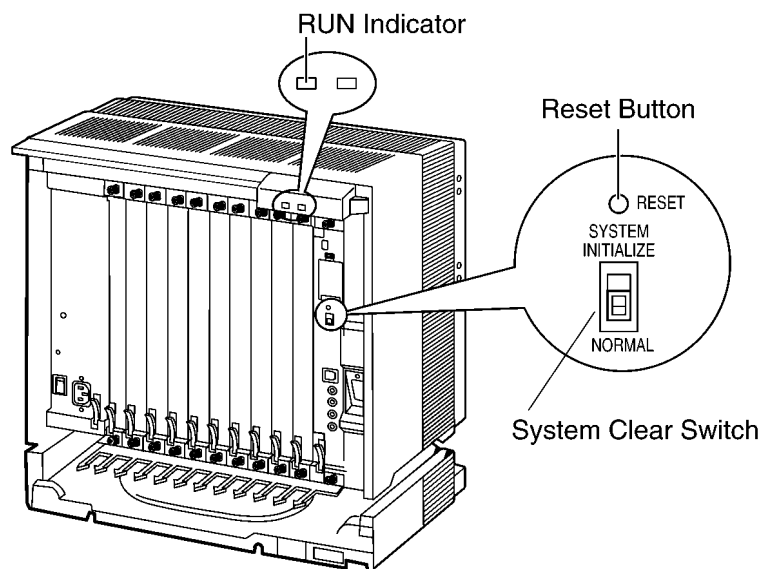

2. If the Hybrid IP-PBX still does not operate properly:

- a. Set the System Clear Switch to the "SYSTEM INITIALIZE" position.
- b. Press the Reset Button.
- c. Return the System Clear Switch to the "NORMAL" position while the RUN indicator is flashing (within approximately 10 s).

Note:

As a result of Step 2, all the programmed data will be cleared.

3. If the Hybrid IP-PBX still does not work, unplug the Hybrid IP-PBX and plug it in again after 5 minutes.

4. If the Hybrid IP-PBX still does not work:

- a. Unplug the Hybrid IP-PBX.
- b. Set the System Clear Switch to the "SYSTEM INITIALIZE" position.
- c. Plug in the Hybrid IP-PBX.
- d. Press the Reset Button.
- e. Set the System Clear Switch to the "NORMAL" position while the RUN indicator is flashing (within approximately 10 s).

Installing Optional Service Cards

1. Insert the card along the guide rails.

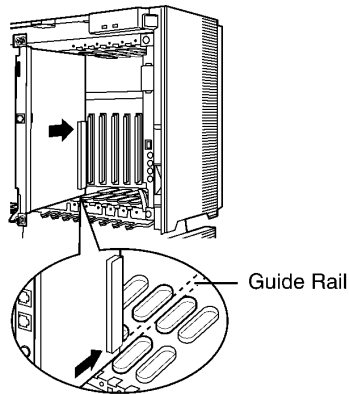

2. Holding the card as follows, push the release lever in the direction of the arrow so that the card is made to engage with the connector on the back board securely.

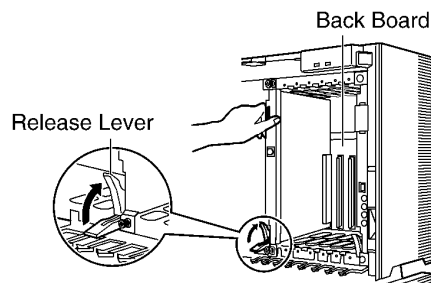

3. Turn the 2 screws clockwise to fix the card.

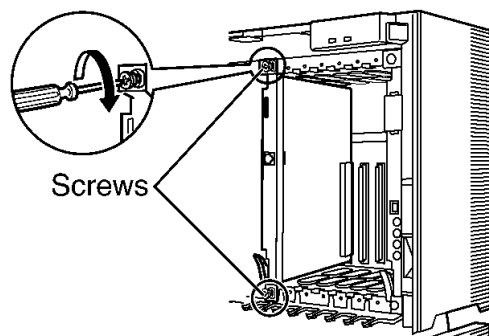

5 TROUBLESHOOTING GUIDE

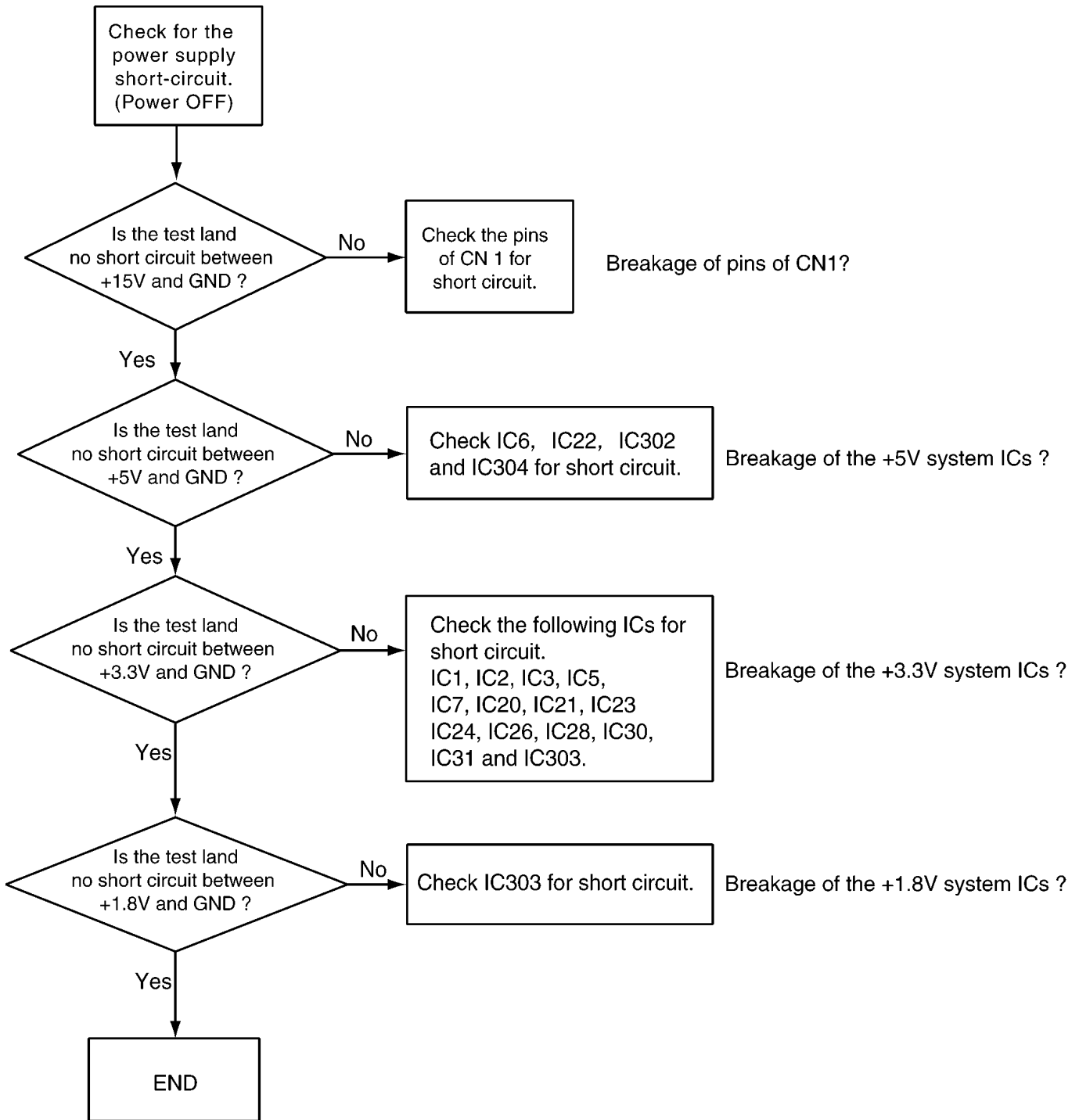

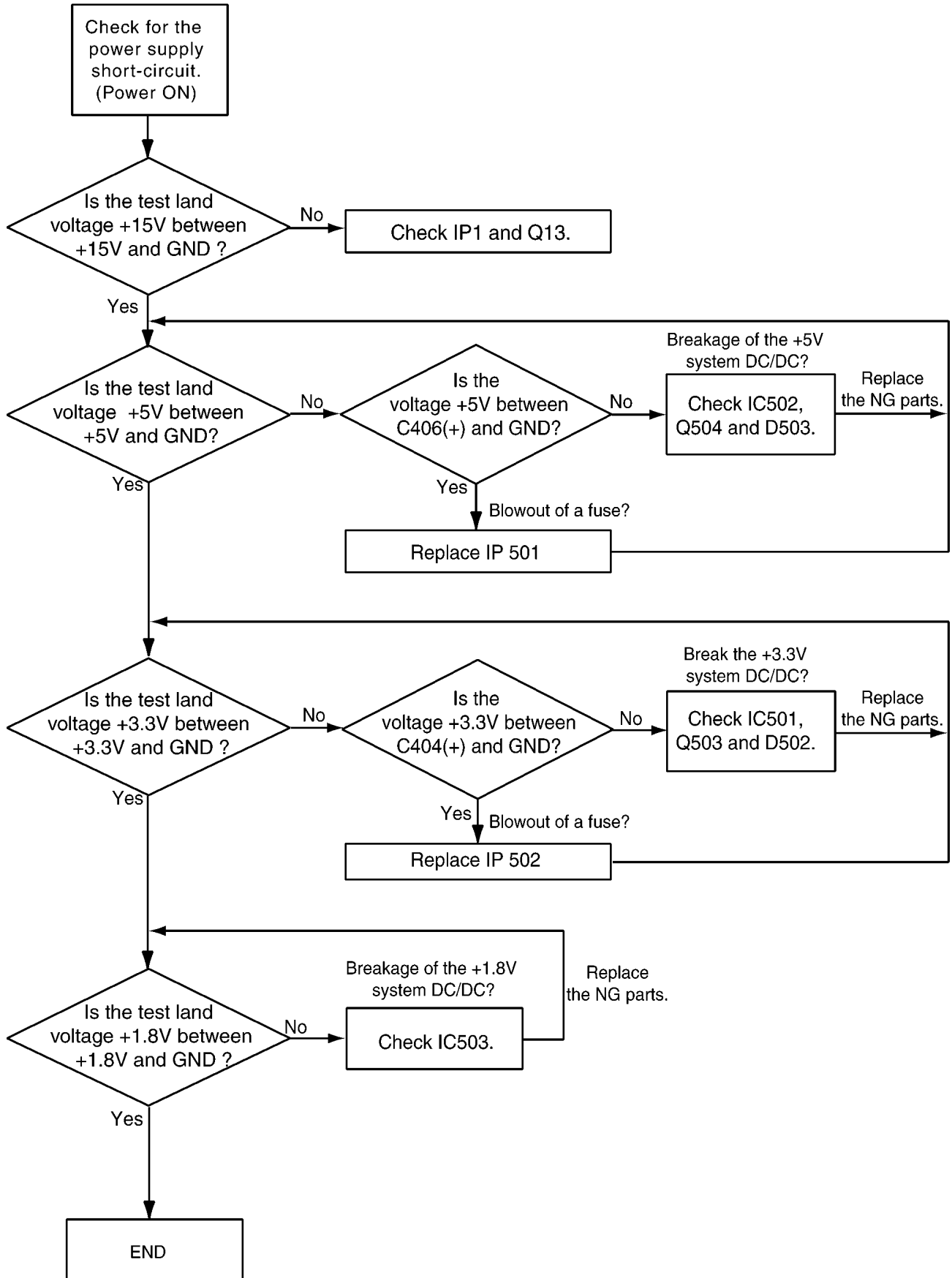

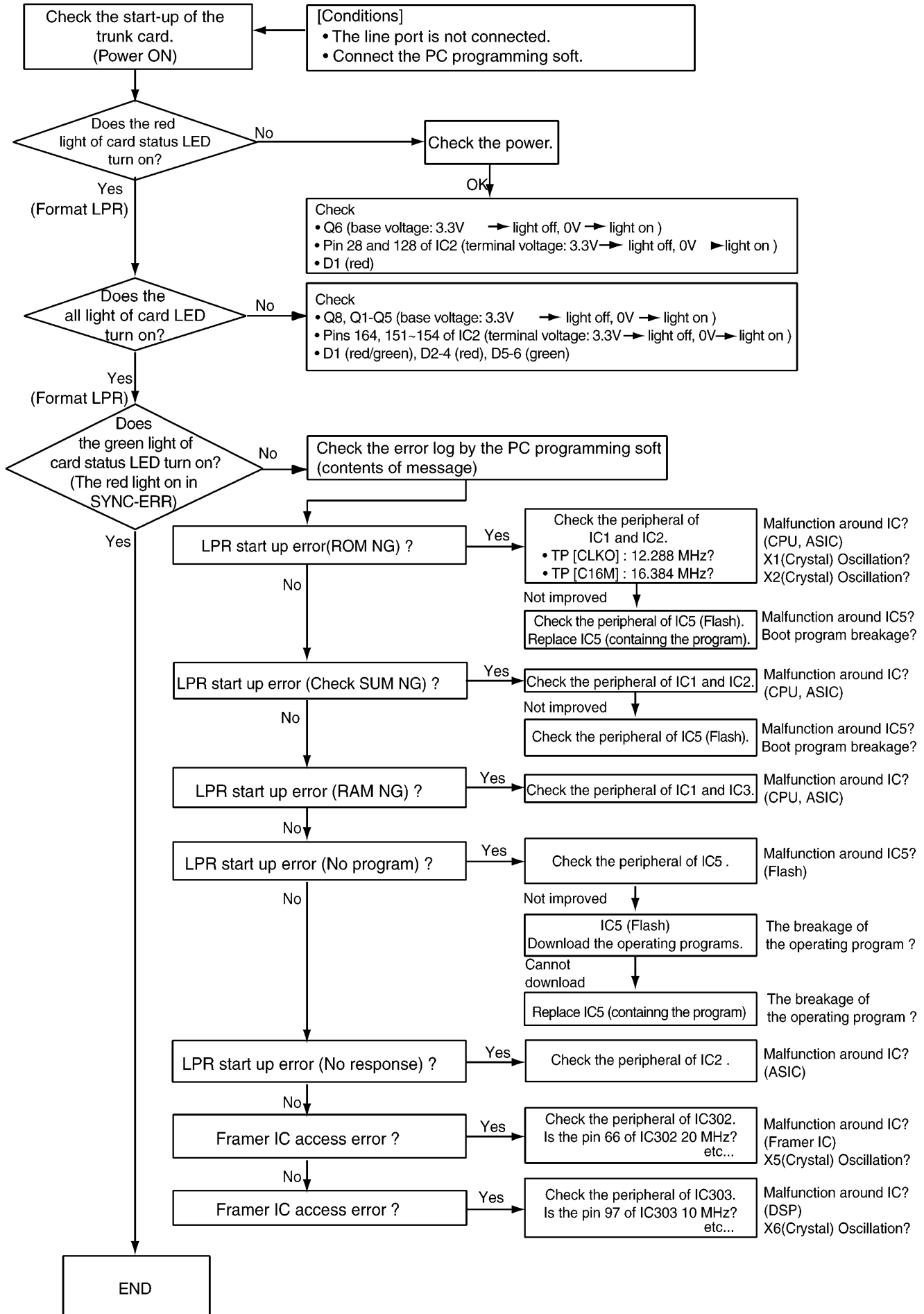

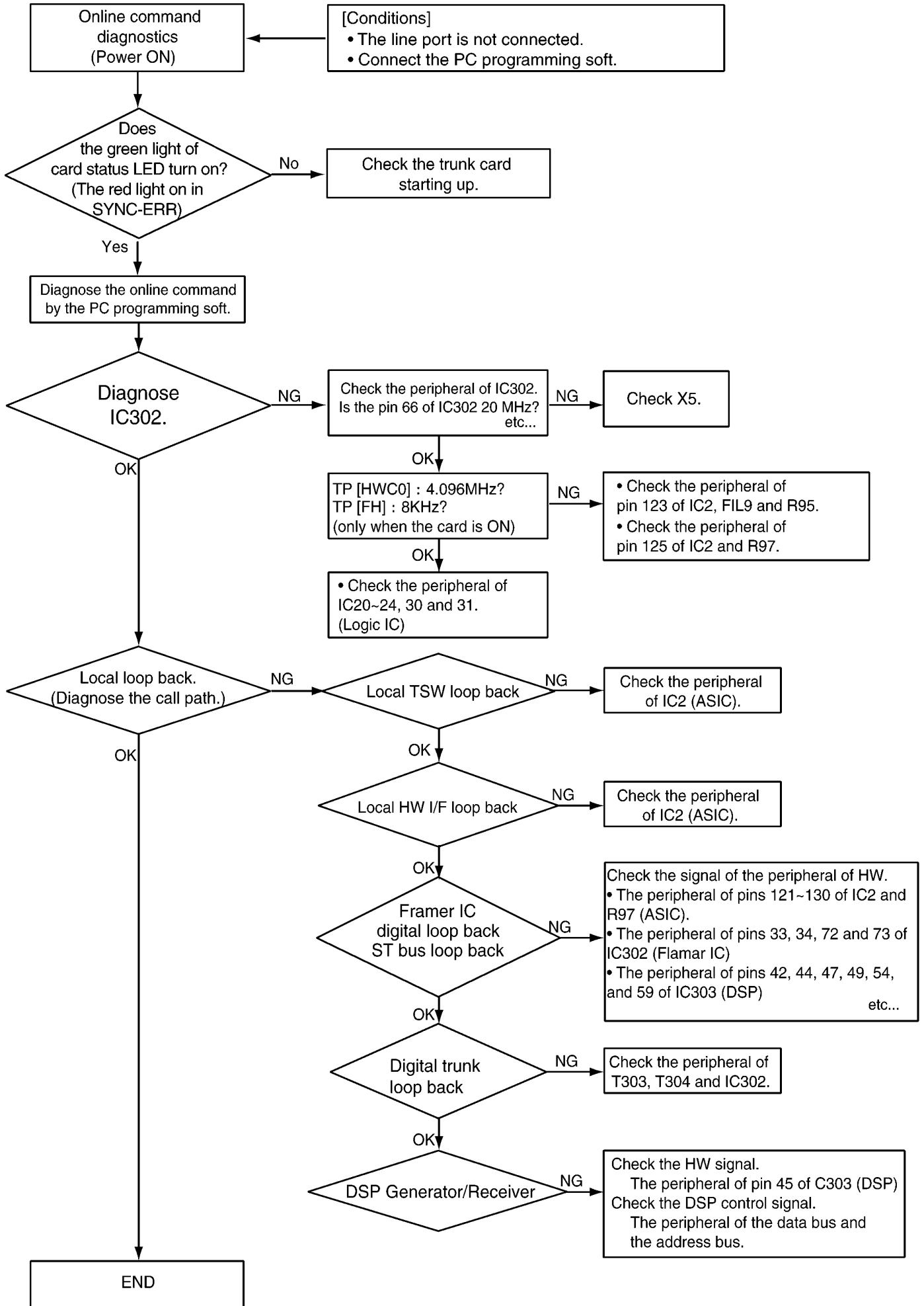

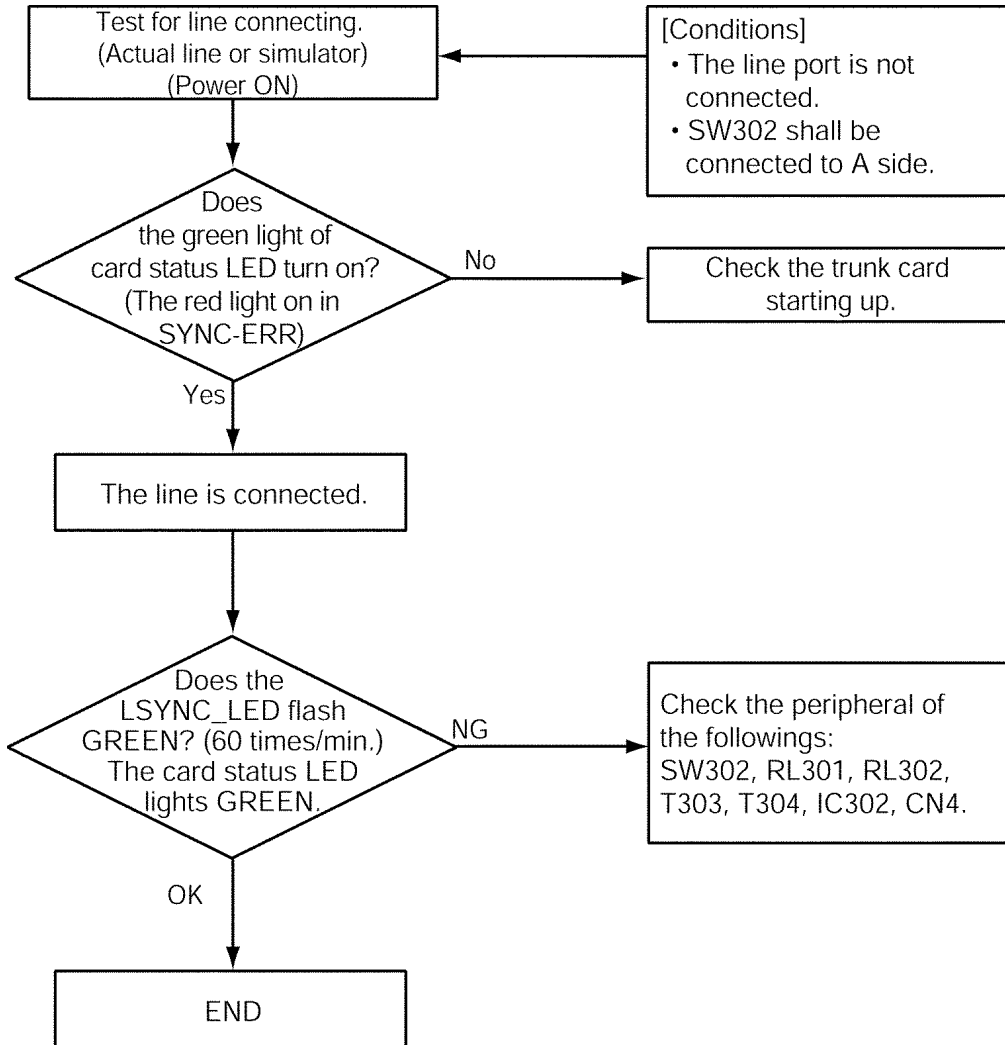

6 BLOCK DIAGRAM

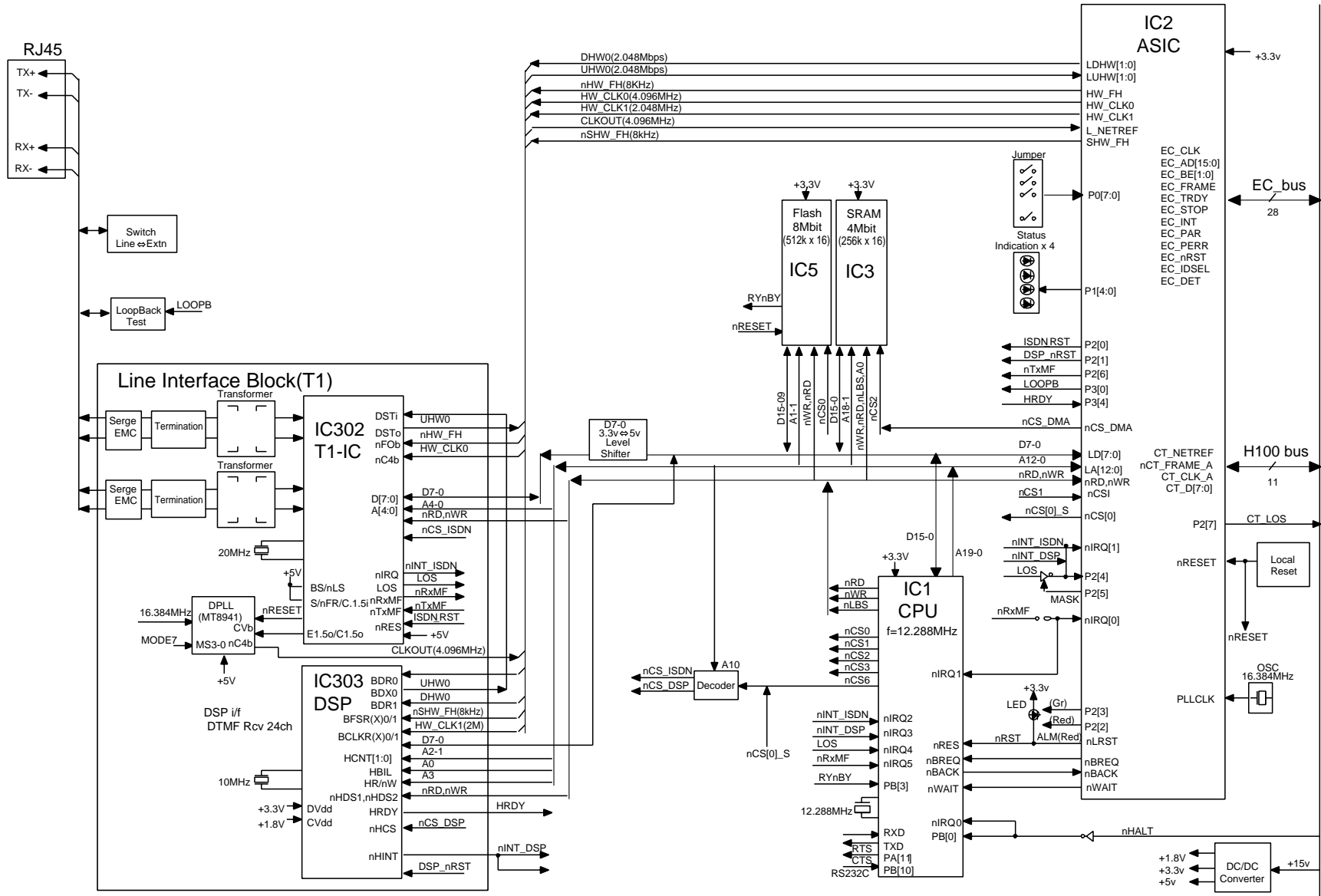

KX-TDA0187 BLOCK DIAGRAM

7 CIRCUIT OPERATION

7.1. CPU PERIPHERAL FUNCTION

The CPU (IC1) is a single chip microcomputer of RISC architecture.

This item describes a memory interface (program & work) and peripheral functions.

7.1.1. Memory (Program & Work)

Table.5.1 List of the memory (program & work)

Part Name	Size	Purpose	Remarks
Flash (IC5)	4Mbit (256K x 16)	Program Area	Flash memory is employed for the software downloading by on-board.
SRAM (IC3)	4Mbit (256K x 16)	Work Area	

7.1.2. Chip Select Logic

Table.5.2 Table of Chip Select Terminals

Terminals			Function used	Wait Function (Numeral is no. of clocks.)	Remarks
CS Terminals	Individual Output (1)	Individual Output (2)			
nCS0 (area 0)	-	-	nCS0	1+Programable or 1+Programable+WAIT Terminals	Used for Flash memory CS.
nCS1 (area 1)	nCASH (DRAM)	-	nCS1	Read 1/Write 2 or 2+WAIT Terminals	Used for ASIC (IC2) CS
nCS2 (area 2)	-	-	nCS2	1+Programable or 1+Programable+WAIT Terminals	Used for SRAM (Basic) CS. Work Area
nCS3 (area 3)	nCASL (DRAM)	-	nCS3	Read 1/Write 2 or 2+WAIT Terminals	CS Reserve
nCS4 (area 4)	PA0 (I/O)	TIOCA0 (Timer)	nCS4	Read 1/Write 2 or 2+WAIT Terminals	CS Reserve
nCS5 (area 5)	PA1 (I/O)	nRAS (DRAM)	nCS5	Read 1/Write 2 or 2+WAIT Terminals	CS Reserve
nCS6 (area 6)	PA2 (I/O)	TIOCB0 (Timer)	nCS6	1+Programable or 1+Programable+WAIT Terminals	Used for peripheral LSI CS. Used for framer IC, DSP CS.
nCS7 (area 7)	PA3 (I/O)	nWAIT	nWAIT	Read 1/Write 2 or 2+WAIT Terminals	Used for Input Wait Terminals.

Table.5.3 Table of Chip Select Port allocation

Chip Select	Address	Device Bit Wide	Assignment Device	Bus Cycle	Remarks
nCS0	0000000h 0FFFFFFh	16bit	Flash (IC5)	2 Clock (1+Long Wait1)	Port allocation of word by static bus sizing Bus cycle has same setting as Area 2 (nCS2).
nCS1	1000000h 1FFFFFFh	8bit	ASIC (IC2)	2+WAIT Terminals	Port allocation of byte by static bus sizing.
nCS2	A000000h AFFFFFFh	16bit	SRAM (IC3)	2 Clock (1+Long Wait1)	Port allocation of word by static bus sizing Bus cycle has same setting as Area 0 (nCS0).
nCS6	6000000h 6FFFFFFh	8bit	T1_IC (IC302)	3 Clock (1+Long Wait2)	Port allocation of byte by static bus sizing.

7.1.3. Interrupt

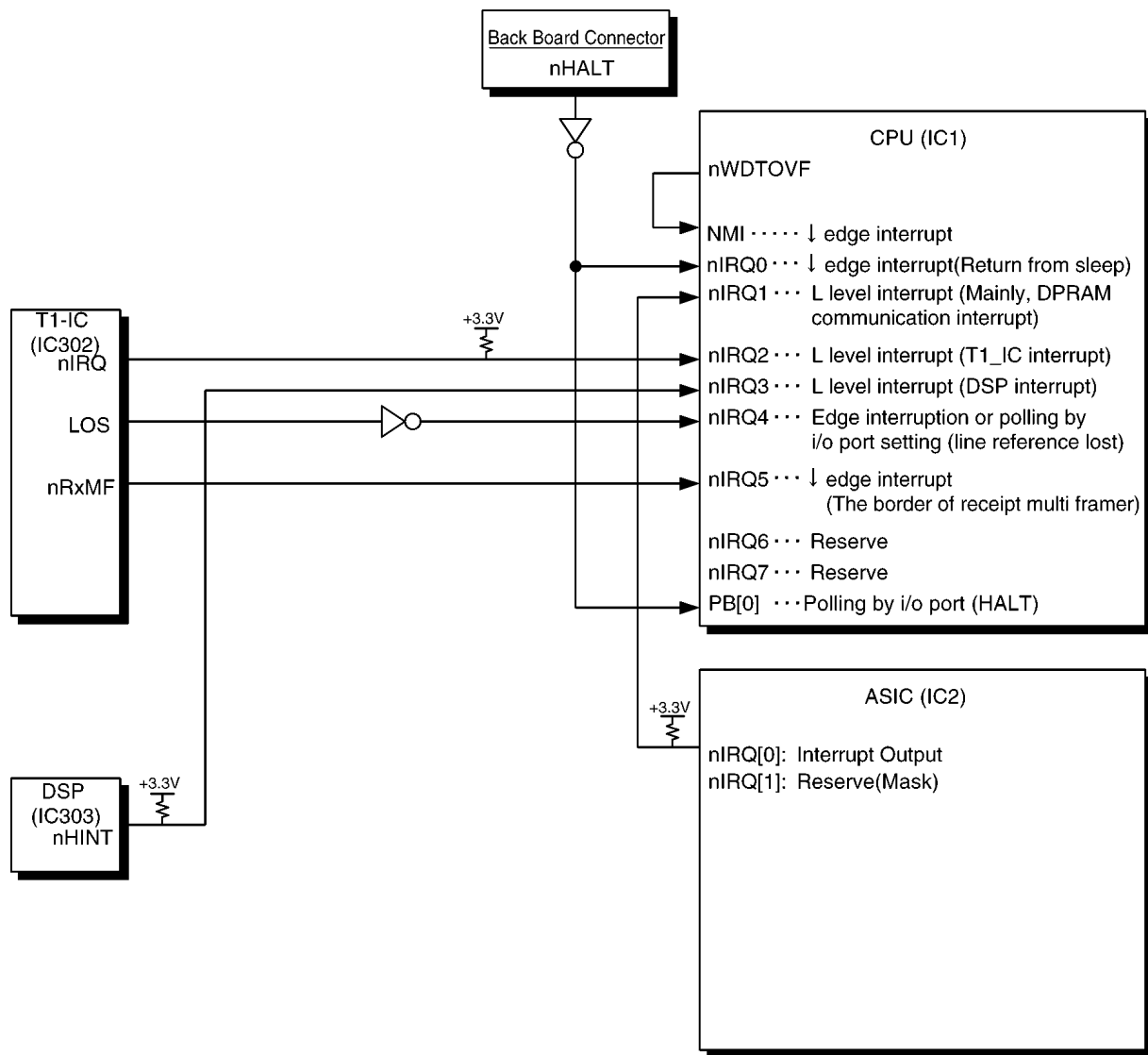

Fig.5.1 External interrupt image

Note:

- nHALT signal is consistent with the existing PBX and performs polling by I/O port. However, when the CPU (IC1) goes to Sleep Mode at HALT, the CPU (IC1) is enabled for interruption on release nHALT and return from Sleep Mode.
- The nIRQ[0] interrupt of ASIC (IC2) is set to output and the interrupt output is to the CPU (IC1) (Mainly, DPRAM communication interrupts).
- The LOS signal of the T1-IC (IC302) is a level output which goes "H level" at the line reference lost. Thus, ↓ edge interruption is available at the line reference lost by inputting the inversion signal of the LOS to the CPU (IC1). The polling operation is also possible by setting the nIRQ4 terminal of the CPU (IC1) to i/o port. (The configuration with the interruption processing is to give a consistency with the existing PBX.)
- Since the nRxMF signal of the T1-IC (IC302) occurs in periodic frame timing, the polling by i/o port is impossible.

7.2. LINE INTERFACE FUNCTION

7.2.1. Line Interface Outline

T1 card uses the T1-IC (IC302)(Mitel) as the IC for the line interface. Fig. 5.2 shows the outline block diagram of the T1-IC (IC302) and Fig. 5.2 shows the characteristics of the T1-IC (IC302).

Also, see the T1-IC (IC302) Data Sheet for the detailed specifications.

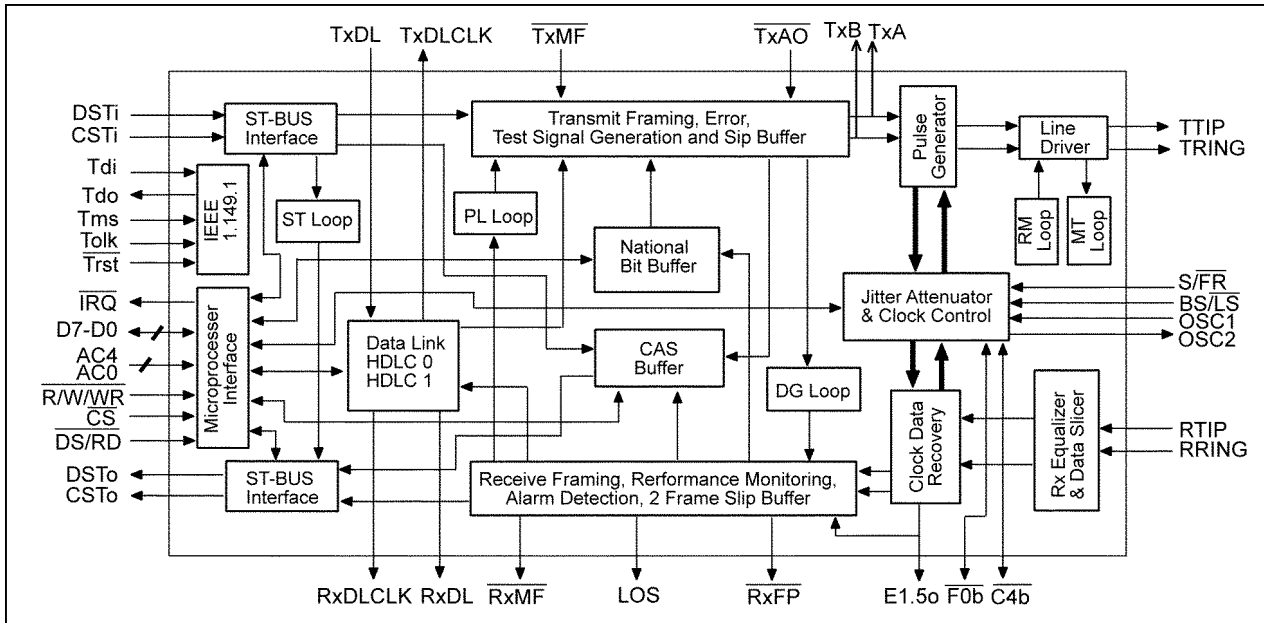

Fig.5.2 Outline block diagram of the T1-IC (IC302)

Table.5.4 Characteristics of the T1-IC (IC302)

Item	Contents	Remarks
Line Extraction Clock	1.544MHz	
DPLL	Low Jitter DPLL for clk generation	
Elastic Buffer	Two-frame elastic buffer (Rx & Tx)	
Signaling Controller	<ul style="list-style-type: none"> • HDLC0: ESF Data Link (4kbps) • HDLC1: DS1 Channel24 (56 or 64kbps) 	Built-in two pieces
FIFO (HDLC0)	128Byte x 2	TX/RX Variable in the range from 16 Byte to 128Byte in increments of 16Byte.
FIFO (HDLC1)	128Byte x 2	TX/RX Variable in the range from 16 Byte to 128Byte in increments of 16Byte.
PCM Highway Interface	ST-BUS Interface (2.048Mbps)	
μP-Interface	8bit parallel Bus (Intel/Motorola)	Used Intel Mode for T1 Card.

7.2.2. Line Interface Loopback

This card has a relay for loopback test on the primary side of the line to cut and divide into the line failure or the PBX's own failure, when there is a defect in operation.

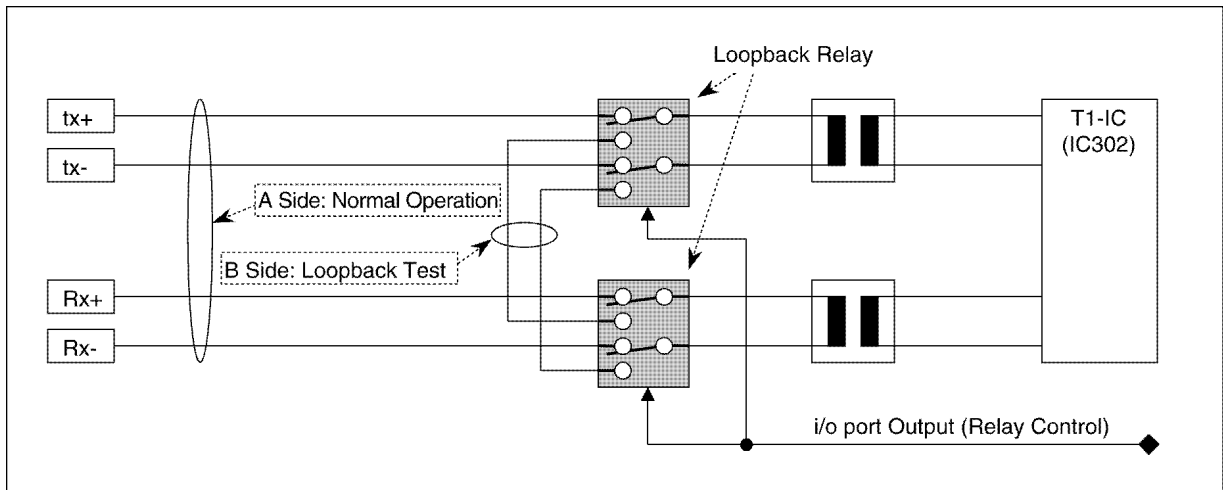

Fig.5.3 Outline diagram of the line interface

7.3. DSP

7.3.1. DSP Function Outline

This card realizes the following functions as in-band signaling function by DSP.

- DTMF Receiver
- DTMF Generator
- MFC-R1/R2 Receiver
- MFCR1/R2 Generator

However, DTMF Generator has also a resource on the Main Body side of the TDA160 system.

Table 5.5 shows a list of the DSP Resources by card type.

See the "DSP Interface Specification for T1 Card" for the details.

Table 5.5 List of DSP Resource by Card Type

Card Type	Function	Resource Target Specification	
		No. of Channels	Procedure of Implementation
T1	DTMF Generator	24	DTMF Generator on the Main Body DSP
	DTMF Receiver	24	DSP
	MFC-R1 Generator	24	DSP
	MFC-R1 Receiver	24	DSP

7.3.2. DSP Peripheral Interface

The function of the DSP shown in Table 5.5 is processed through the PCM highway. The PCM highway is connected with a local highway (2.048Mbps) of the ASIC (IC2) through the McBSP(Multi-Channel Buffered Serial Port) and the control system is connected with the CPU (IC1) local bus through the HPI-8 (Host Port Interface) of the DSP (IC303).

See the DSP (IC303) Data Sheet for the detailed specifications of the McBSP and the HPI-8.

Fig. 5.4 shows the Image View of the DSP (IC303) Internal Processing and Fig. 5.5 shows the Signal Line Connection Diagram.

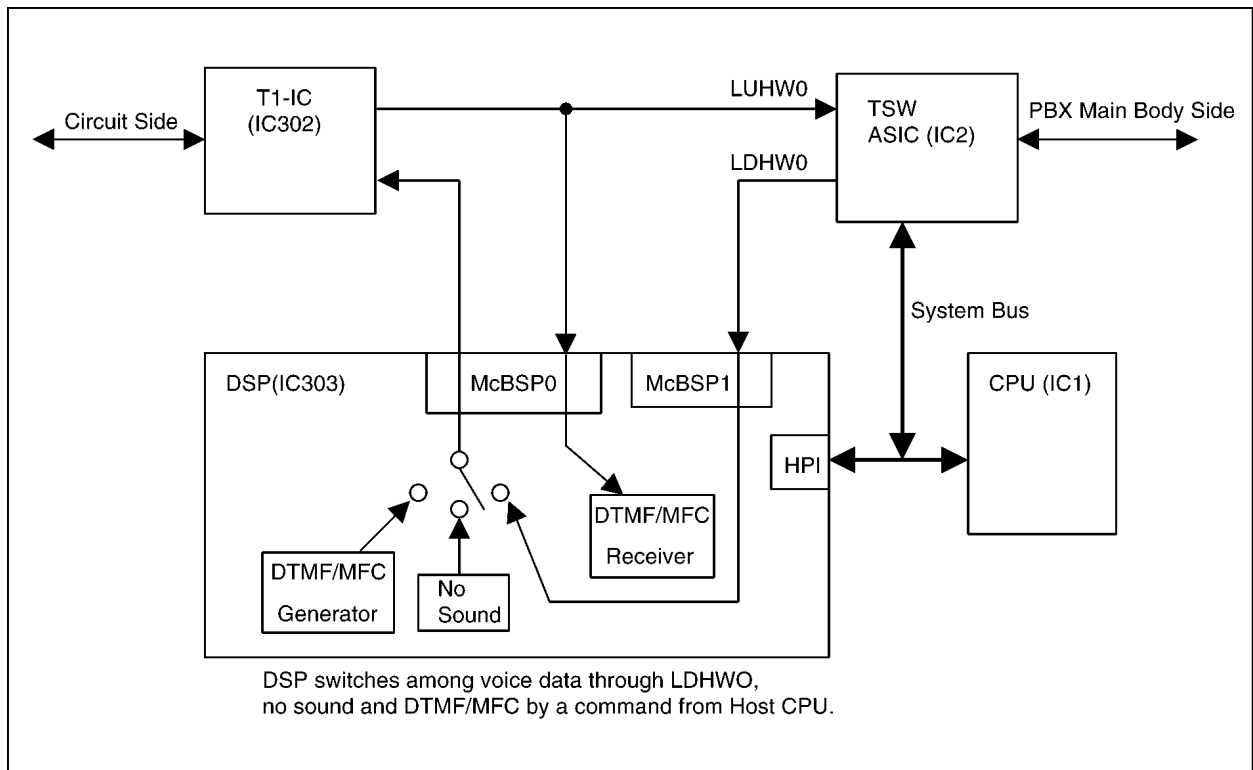

Fig. 5.4 Image View of the DSP (IC303) Internal Processing

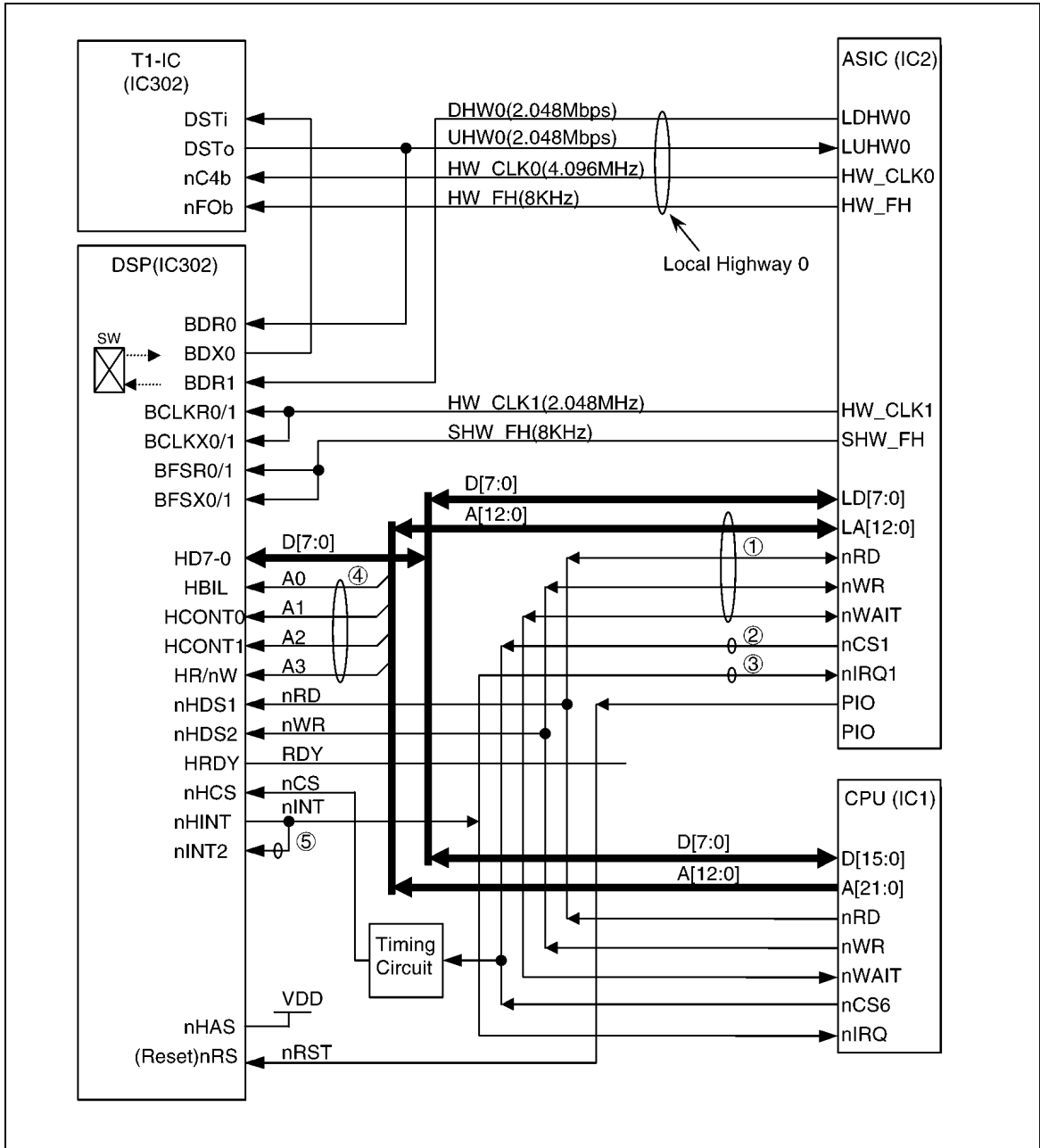

Fig.5.5 New PBX...DSP (IC303) Signal Line Connection Diagram

7.4. LOCAL HIGHWAY INTERFACE FUNCTION

This card has the local highway in the speed of 2.048Mbps and local TSW (ASIC (IC2) internal module) to switch from the call channel (Bch) extracted from T1 line by the T1-IC (IC302), to H.100 interface.

As the switching function inside the DSP (IC303) is used for the in-band signaling detection by the DSP (IC303), there is no assignment directly on the local highway map, but the operation is synchronized with the local highway in timing.

Fig 5.6 shows the Bch Highway Assignment and the Input/Output Timings of the ASIC (IC2), the T1-IC (IC302) and the DSP (IC303).

See the ASIC (IC2) Specification, the T1-IC (IC302) Data Sheet and the DSP (IC303) Data Sheet for the details.

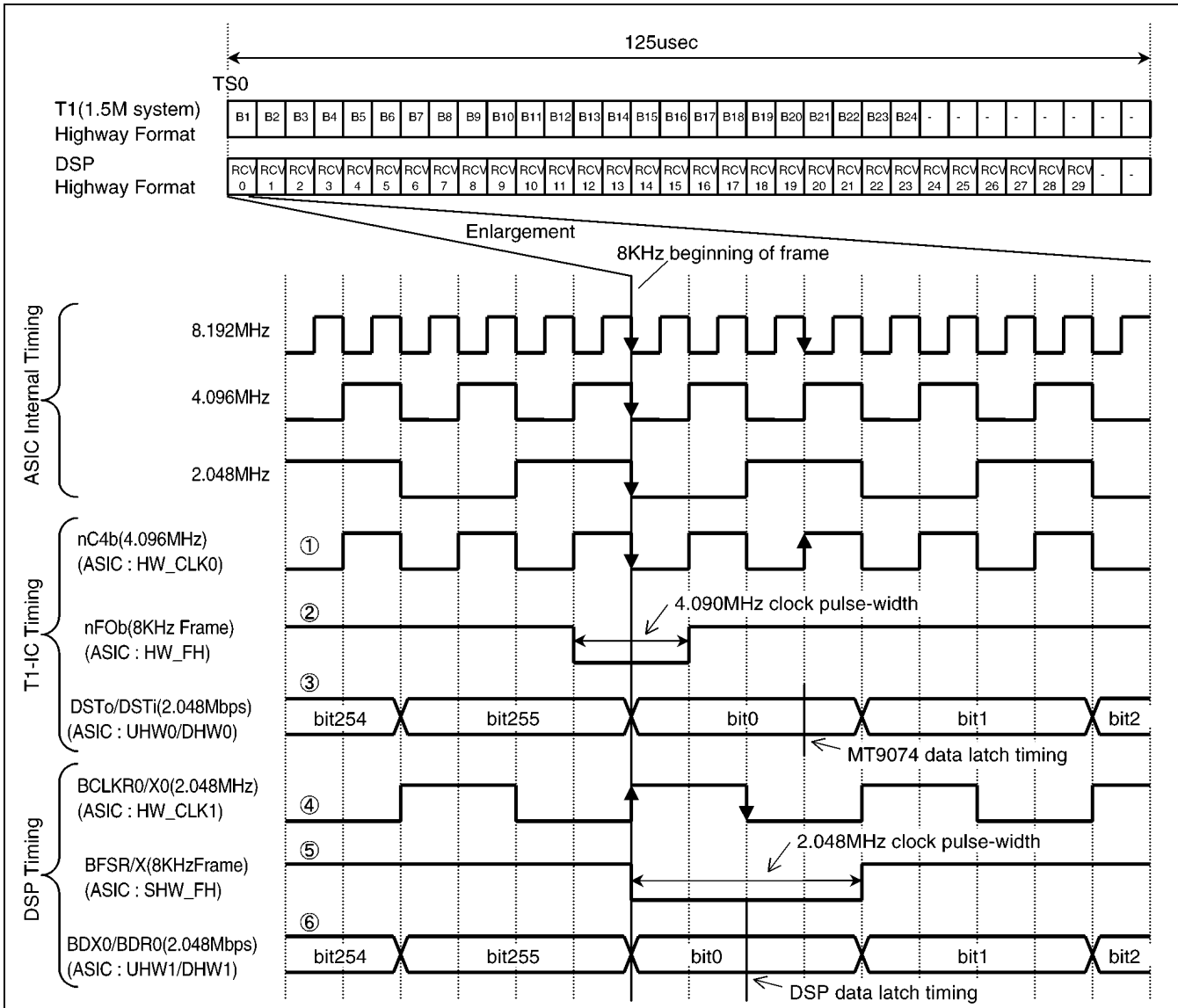

Fig 5.6 Shows the Bch Highway Assignment and the Input/Output Timings of the ASIC (IC2), the T1-IC (IC302) and the DSP (IC303)

7.5. EC BUS INTERFACE

7.5.1. Dual Port RAM (DPRAM) Communication

This card transmits and receives data between CPU (IC1) and MPR (EC bus) in a dual port RAM communication basically. Fig.5.7 shows the diagrammatic illustration.

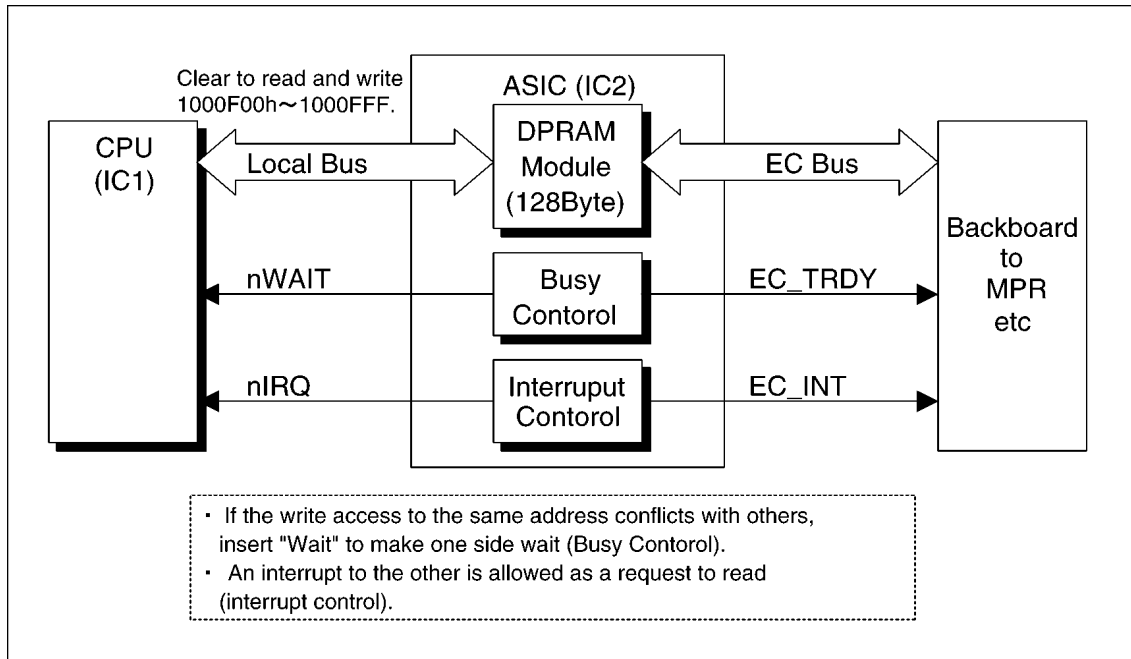

Fig.5.7 DPRAM Communication diagrammatic illustration

7.6. OUTLINE OF RESET SYSTEM

7.6.1. Reset Operation

A reset to CPU (IC1) (and the device under the control of CPU (IC1)) in this card is dominant in a reset from the main frame (MPR), and normally it is only available for software command reset or hardware reset using ASIC (IC2) from MPR. The power on reset circuit in this card is for the reset of ASIC (IC2) in a hot plug.

Table 5.6 shows the Reset Type of the T1 card and Fig.5.8 shows the Reset System Diagram.

Table.5.6 Reset Class

Reset Type	The way of Reset		Specification
Reset to ASIC (IC2)	OR condition of the following Reset		L active
	Power on reset	Reset by the reset IC Reset IC specifications Power Supply voltage : 5V Reset voltage : 4.5V Reset delay time : 50msec	Over 10msec
	Hardware reset from the EC bus	Reset by EC_RST	Over 10msec
	Software reset from the EC bus	Cancel after a given length of time	16cycles after EC_CLK about 2usec
Reset to CPU (IC1)	Software reset from the EC bus	ASIC (IC2) local reset register control	L active Over 10msec (up to stable PLL)
Reset to Flash	Software reset from the EC bus	Same as the reset to CPU (IC1)	L active Over 500nsec
Reset to T1-IC (IC302)	Software reset from the CPU (IC1)	ASIC (IC2) port P2[0] control	L active Over 1µmsec
Reset to DSP (IC303)	Software reset from the CPU (IC1)	ASIC (IC2) port P2[1] control	L active Over 50µmsec

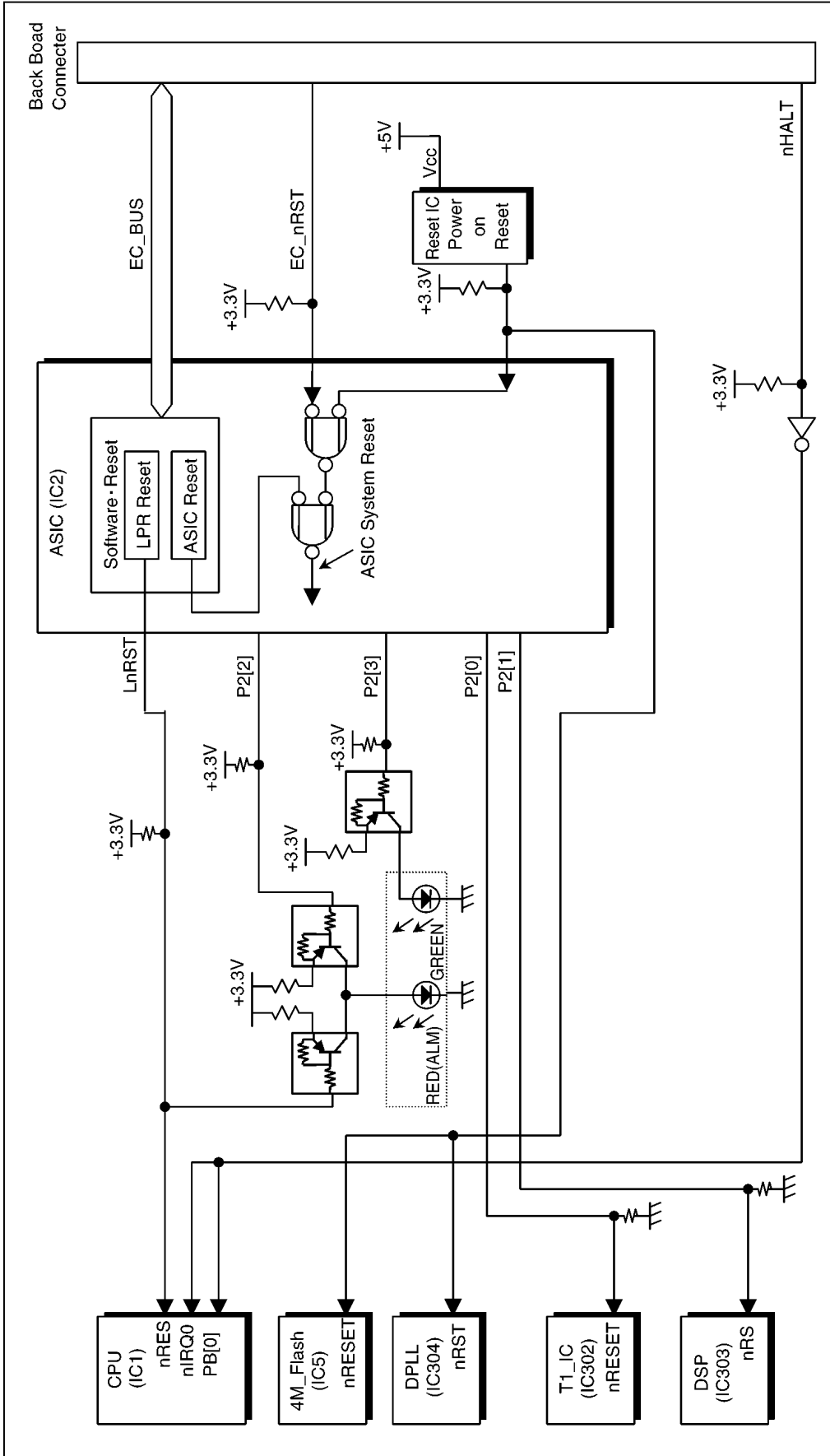

Fig.5.8 A reset schematic diagram

7.7. POWER SUPPLY

This card is supplied +15V power through the backboard connector (90pin) from the power supply unit.

The +15V power supply generates +5V, +3.3V and +1.8V via DC/DC converter, and they are fed as the power of circuit in the card.

The +40V power supply is not used due to no feeding to the line.

Fig.5.9 shows the system diagram of the power supply.

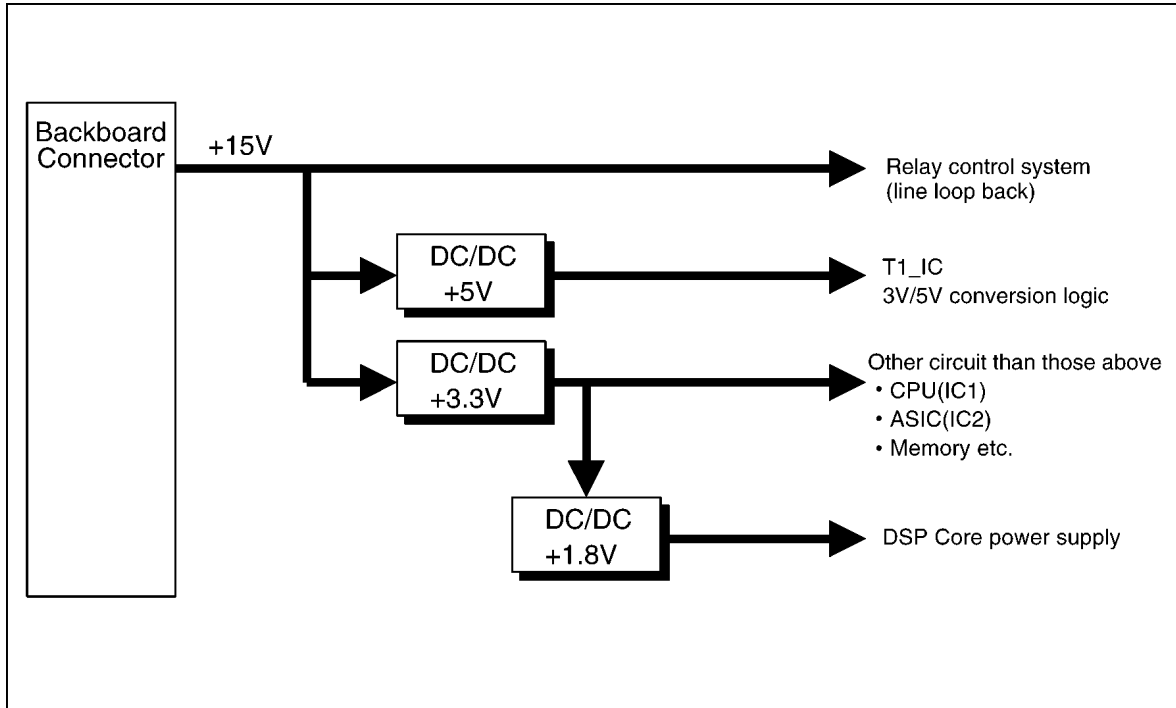
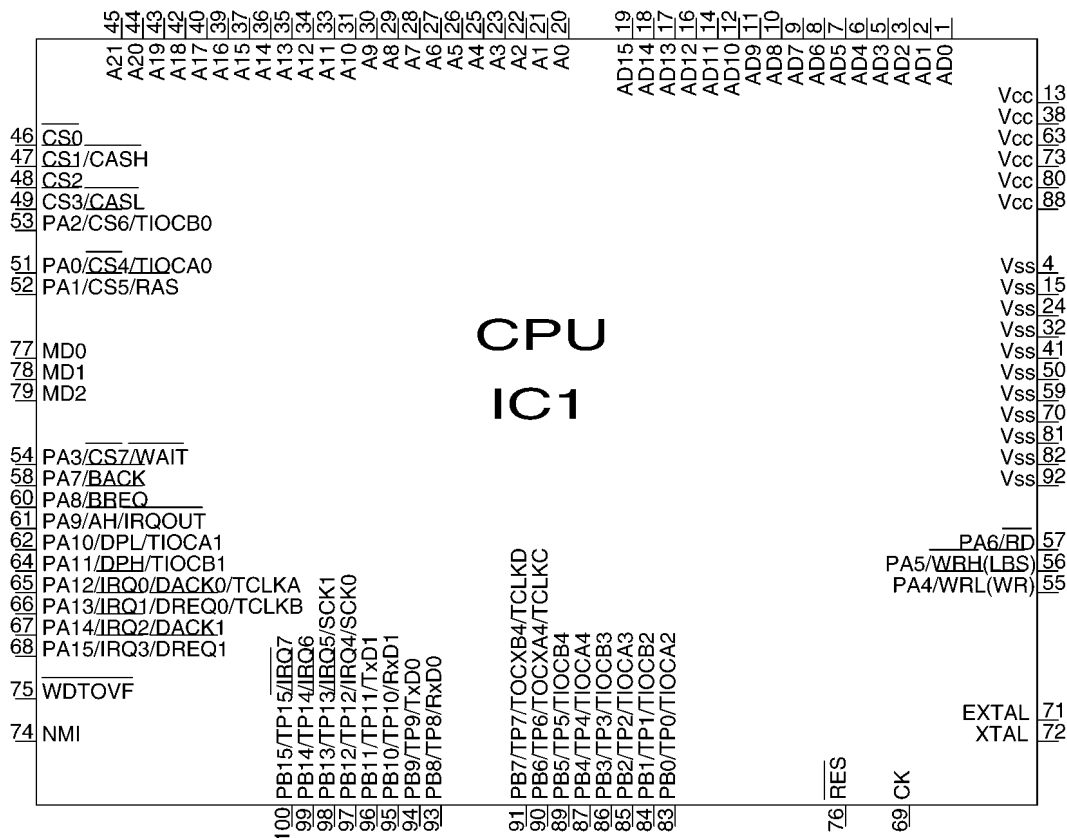

Fig.5.9 System diagram of the power supply

8 IC DATA

8.1. IC1 (CPU)



Port	Pin	Terminals	I/O	ACT	Description	
PA	15	68	nIRQ3	I	L	Reserve (interrupt)
	14	67	nIRQ2	I	L	T1_IC(IC302) interrupt
	13	66	nIRQ1	I	L	Interrupt for SAMSON (ASIC) (mainly DPRAM communication interrupt for MPR)
	12	65	nIRQ0	I	L	DC power down recovery detection inversion signal of CPU (IC1) inversion signal (L:recovery)
	11	64	PA11	O	L	UART port for request to send [RTS0] (RS232C)
	10	62	PA10	I	L	UART port for clear to send [CTS0] (RS232C)
	9	61	PA9	-	-	Reserve (general-purpose i/o)
	8	60	nBREQ	I	L	Bus request signal (bus arbitration)
	7	58	nBACK	O	L	Bus acknowledge signal (bus arbitration)
	6	57	nRD	O	L	Read signal (bus control)
	5	56	nLBS	O	L	Low byte strobe signal (bus control)
	4	55	nWR	O	L	Write signal(bus control)
	3	54	nWAIT	O	L	Wait signal(bus control)
	2	53	nCS6	O	L	Chip select 6 signal(bus control)
1	52	PA1	-	-	Reserve (Chip Select 5 signal)	
0	51	PA0	-	-	Reserve (Chip Select 4 signal)	

Port	Pin	Terminals	I/O	ACT	Description	
PB	15	100	nIRQ7	-	-	Reserve (interrupt)
	14	99	nIRQ6	-	-	Reserve (interrupt)
	13	98	nIRQ5	I	L	Line Reception Multi-frame Boundary Signal Input (nRxMF)
	12	97	nIRQ4	I	L	Line Reference Lost Interruption, or Polling by i/o Setting (LOS)
	11	96	PB11	-	-	Reserve (general-purpose i/o)
	10	95	PB10	-	-	Reserve (general-purpose i/o)
	9	94	TxD0	O	H/L	UART port to send data [TxD0] (RS232C)
	8	93	RxD0	I	H/L	UART port to receive data [RxD0] (RS232C)
	7	91	PB7	-	-	Reserve (general-purpose i/o)
	6	90	PB6	-	-	Reserve (general-purpose i/o)
	5	89	PB5	I	L	For manufacturing test L:Manufacturing test mode
	4	87	PB4	I	L	For card single debugging L:debug mode
	3	86	PB3	I	L	Flash memory busy input (L:busy)
	2	85	PB2	I	L	Reserve (general-purpose i/o)
	1	84	PB1	I	L	Reserve (general-purpose i/o)
0	83	PB0	I	H	CPU (IC1) inversion signal (H:inversion)	

8.2. IC2 (ASIC)

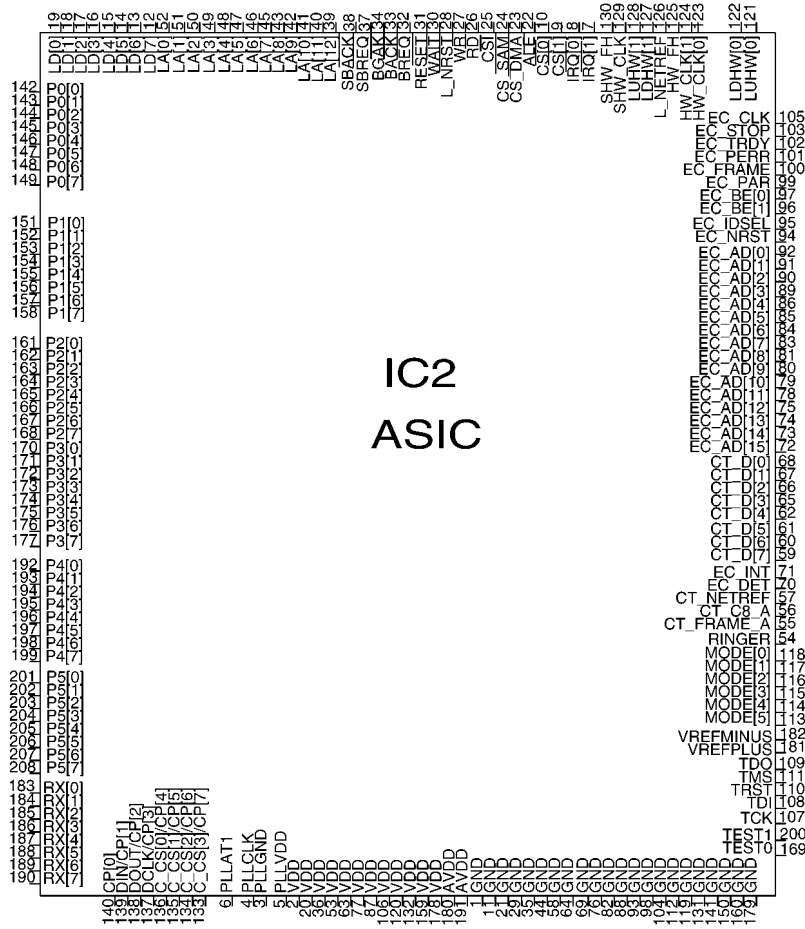

Port	Pin	Terminals	I/O	ACT	Descriptions	
P0	7	149	PO[7]	I	H/L	Reserve (Jumper setup)
	6	148	PO[6]	I	H/L	Reserve (Jumper setup)
	5	147	PO[5]	I	H/L	Reserve (Jumper setup)
	4	146	PO[4]	I	H/L	Hardware version control bit2 (Jumper setup)
	3	145	PO[3]	I	H/L	Hardware version control bit1 (Jumper setup)
	2	144	PO[2]	I	H/L	Hardware version control bit0 (Jumper setup)
	1	143	PO[1]	I	H/L	Number of lines info bit1 (Jumper setup)
	0	142	PO[0]	I	H/L	Number of lines info bit0 (Jumper setup)
P1	7	158	P1[7]	-	-	Reserve
	6	157	P1[6]	-	-	Reserve
	5	156	P1[5]	-	-	Reserve
	4	155	P1[4]	-	-	Line Condition Display LED...Green Data Link (L:Blink)
	3	154	P1[3]	O	L	Line Condition Display LED...Green Sync (L:Blink)
	2	153	P1[2]	O	L	Line Condition Display LED...Red AIS (L:Blink)
	1	152	P1[1]	O	L	Line Condition Display LED...Red RAI (L:Blink)
	0	151	P1[0]	O	L	Line Condition Display LED...Red Sync Err (L:Blink)
P2	7	168	P2[7]	O	H	Line Reference Lost Signal Output (H:Reference Lost)
	6	167	P2[6]	O	L	Line Transmission Multi-frame Boundary Signal Output (nTxMF)
	5	166	P2[5]	O	H	"Line Reference Lost Interruption Mask Output (O: Mask Cancellation 1: Mask)"
	4	165	P2[4]	I	H	Reserve
	3	164	P2[3]	O	L	Card Operating State Display LED...Green(L:Blink)
	2	163	P2[2]	O	L	Card Operating State Display LED...Red (L:Blink)
	0	161	P2[0]	O	L	T1-IC (IC302) Reset(H:Reset)

Port	Pin	Terminals	I/O	ACT	Descriptions	
P3	7	177	P3[7]	-	-	Reserve
	6	176	P3[6]	-	-	Reserve
	5	175	P3[5]	-	-	Reserve
	4	174	P3[4]	I	H	DSP HPI Port DSP Ready Signal (H: Ready)
	3	173	P3[3]	-	-	Reserve
	2	172	P3[2]	-	-	Reserve
	1	171	P3[1]	-	-	Reserve
	0	170	P3[0]	O	L	Line Loopback (L:Normal Operation, H: Loopback)
P4	7	199	P4[7]	-	-	Reserve
	6	198	P4[6]	-	-	Reserve
	5	197	P4[5]	-	-	Reserve
	4	196	P4[4]	-	-	Reserve
	3	195	P4[3]	-	-	Reserve
	2	194	P4[2]	-	-	Reserve
	1	193	P4[1]	-	-	Reserve
	0	192	P4[0]	-	-	Reserve
P5	7	208	P5[7]	-	-	Reserve
	6	207	P5[6]	-	-	Reserve
	5	206	P5[5]	-	-	Reserve
	4	205	P5[4]	-	-	Reserve
	3	204	P5[3]	-	-	Reserve
	2	203	P5[2]	-	-	Reserve
	1	202	P5[1]	-	-	Reserve
	0	201	P5[0]	-	-	Reserve

9 HOW TO REPLACE A FLAT PACKAGE IC

9.1. PREPARATION

- PbF (: Pb free) Solder
- Soldering Iron

Tip Temperature of 700°F ± 20°F (370°C ± 10°C)

Note: We recommend a 30 to 40 Watt soldering iron. An expert may be able to use a 60 to 80 Watt iron where someone with less experience could overheat and damage the PCB foil.

- Flux

Recommended Flux: Specific Gravity → 0.82.

Type → RMA (lower residue, non-cleaning type)

Note:

See **ABOUT LEAD FREE SOLDER (PbF: Pb Free) (P.3)**.

9.2. PROCEDURE

1. Tack the flat pack IC to the PCB by temporarily soldering two diagonally opposite pins in the correct positions on the PCB.

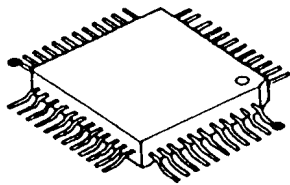

- - - - - - Temporary soldering point.

Be certain each pin is located over the correct pad on the PCB.

2. Apply flux to all of the pins on the IC.

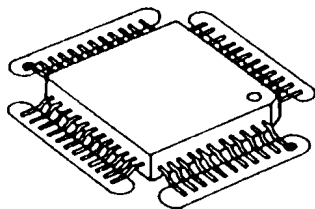

3. Being careful to not unsolder the tack points, slide the soldering iron along the tips of the pins while feeding enough solder to the tip so that it flows under the pins as they are heated.

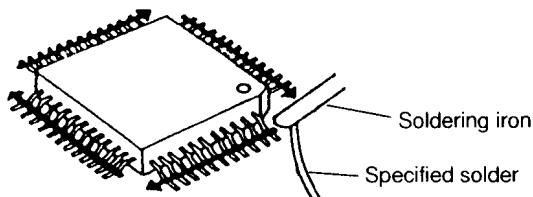

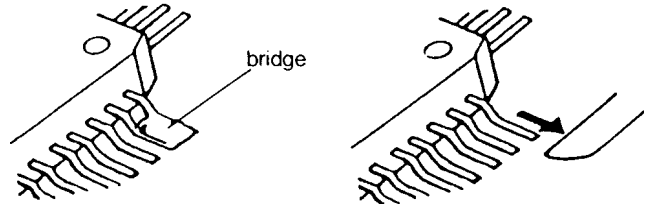

9.3. REMOVING SOLDER FROM BETWEEN PINS

1. Add a small amount of solder to the bridged pins.
2. With a hot iron, use a sweeping motion along the flat part of the pin to draw the solder from between the adjacent pads.

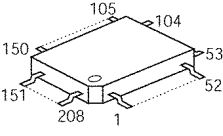
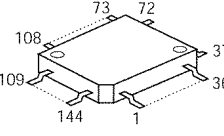
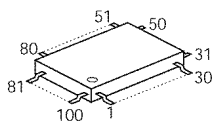
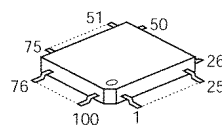
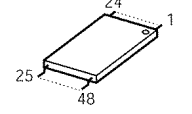
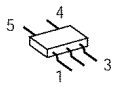
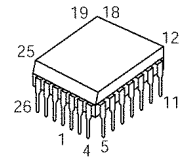
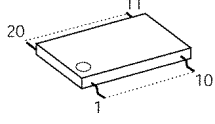
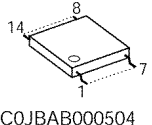
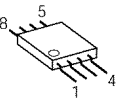
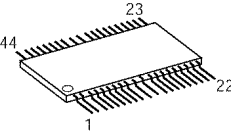
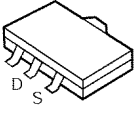
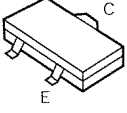
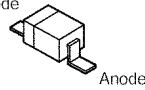

10 TERMINAL GUIDE OF ICS, TRANSISTORS AND DIODES

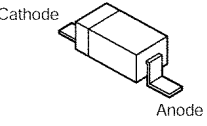
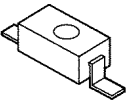
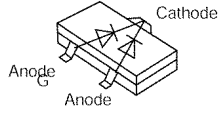
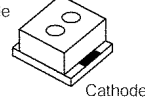
 <p>C1CB00001430</p>	 <p>PSVI320V542P</p>	 <p>PSVIMT9074AL</p>	 <p>PFVI7020VX12</p>	 <p>PSWITDA0187X</p>
 <p>C0CBCAC00010 PQVIS8520F33 C0DBAHA00011 PSVIPST596CN</p>	 <p>C1CB00001181</p>	 <p>COJBAZ001610</p>	 <p>COJBAB000504 COJBAB000507 PSVITC7VC32T COJBAZ001401 PFVITC74V00T COJBAZ001704 PSVISNLV74AP</p>	 <p>C1CB00001497</p>
 <p>C3BBKG000060</p>	 <p>B1DHCD000018, B1DFDC000002</p>	 <p>PFVTMUN5232 PQVTDTA114EU PQVTDTC143E</p>	 <p>MA2J11100L MA8051 MA8075</p>	 <p>PSVDDALC208</p>
 <p>PFVDDGD1FP3T</p>	 <p>PSVD1VGCT PSVD1SRCT</p>	 <p>MA142WKTX</p>	 <p>PQVDBRPY1204</p>	

11 CABINET AND ELECTRICAL PARTS LOCATION

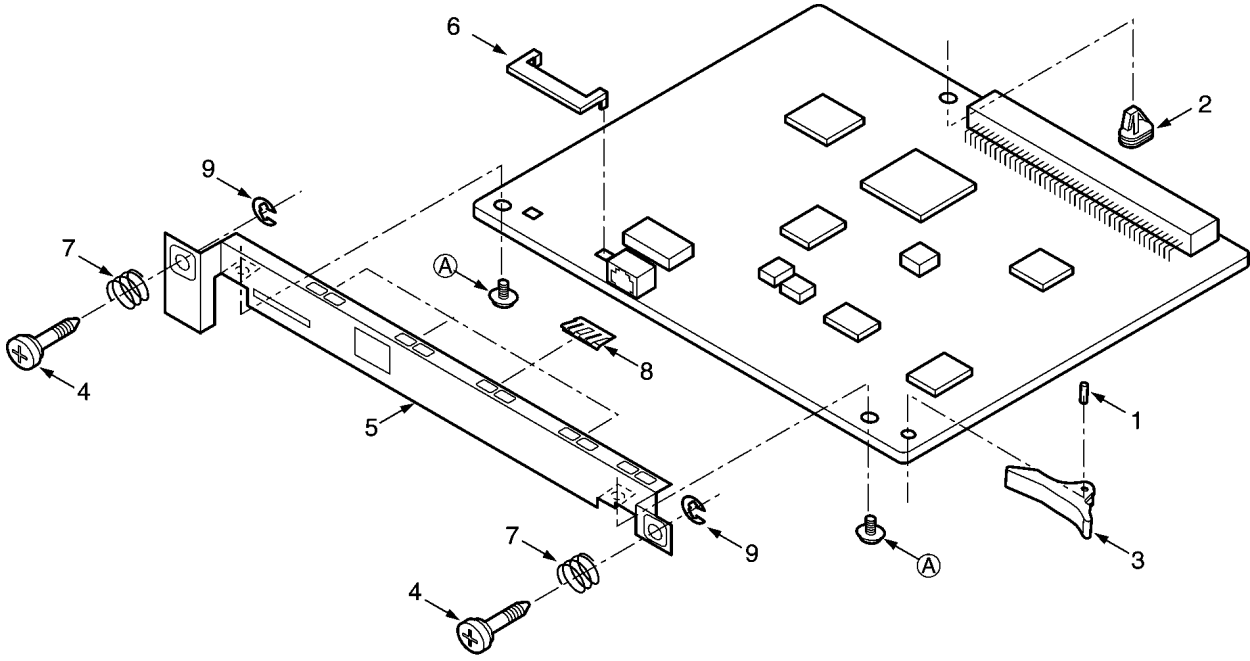

SCREW

Ref. No.	Part No.	Screw
A	XYN3+F6	 ϕ 3 x 6 mm

12 ACCESSORIES AND PACKING MATERIALS

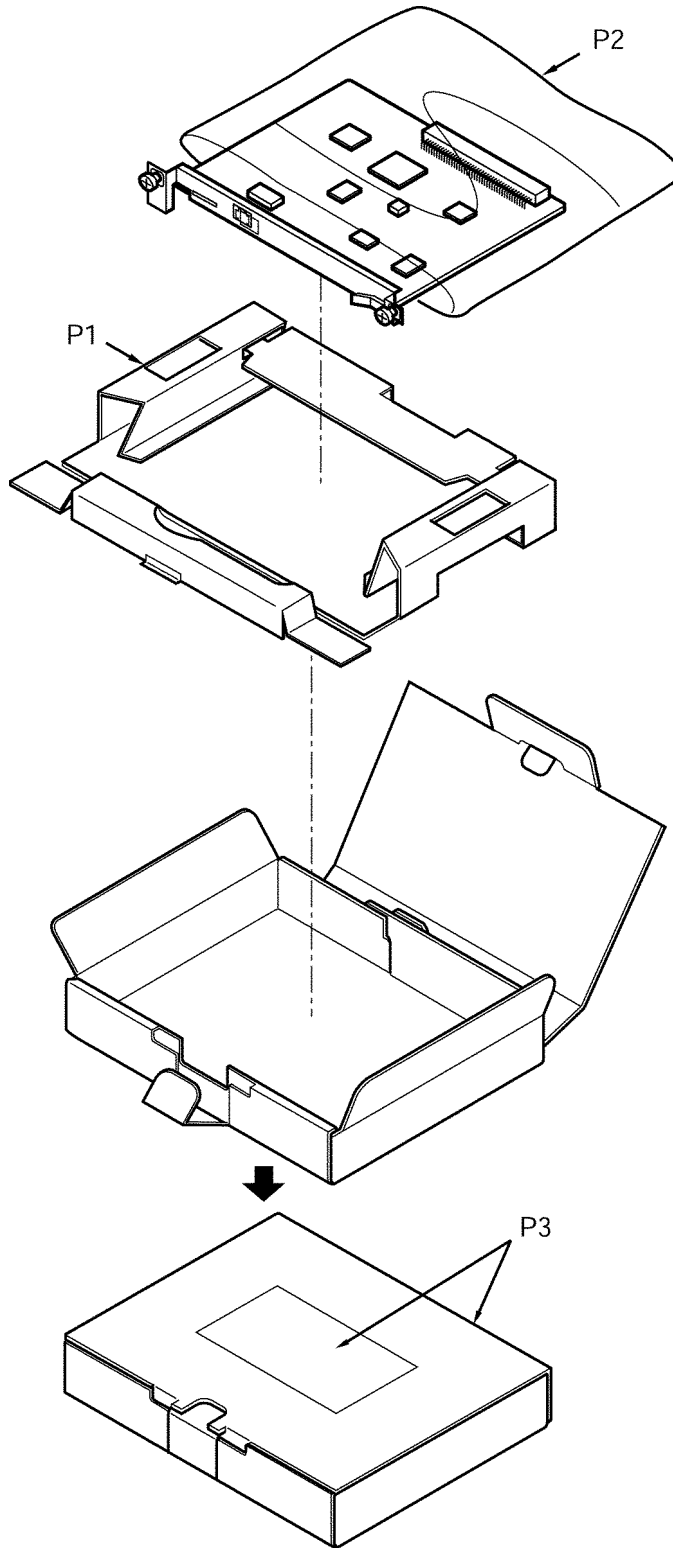

13 REPLACEMENT PARTS LIST

1. RTL (Retention Time Limited)

Note : The marking (RTL) indicates that the Retention Time is limited for this item.

After the discontinuation of this assembly in production, the item will continue to be available for a specific period of time. The retention period of availability is depends on the type of assembly, and in accordance with the laws governing parts and product retention.

After end of this period, the assembly will no longer be available.

2. Important safety notice

Components identified by Δ mark have special characteristics important for safety. When replacing any of these components, use only manufacture's specified parts.

3. The S mark means the part is one of some identical parts.

For that reason, it may be different from the installed part.

4. ISO code (Example: ABS-94HB) of the remarks column shows quality of the material and a flame resisting grade about plastics.

5. RESISTORS & CAPACITORS

Unless otherwise specified;

All resistors are in ohms (Ω) K=1000 Ω , M=1000k Ω

All capacitors are in MICRO FARADS (μ F) P= μ μ F

*Type & Wattage of Resistor

Type

ERC:Solid	ERX:Metal Film	PQ4R:Carbon
ERD:Carbon	ERG:Metal Oxide	ERS:Fusible Resistor
PQRD:Carbon	ER0:Metal Film	ERF:Cement Resistor

Wattage

10,16:1/8W	14,25:1/4W	12:1/2W	1:1W	2:2W	3:3W
------------	------------	---------	------	------	------

*Type & Voltage of Capacitor

Type

ECFD:Semi-Conductor	ECCD,ECKD,ECBT,PQCBC: Ceramic
ECQS:Styrol	ECQE,ECQV,ECQG: Polyester
PQCUV:Chip	ECEA,ECSZ: Electrolytic
ECQMS:Mica	ECQP: Polypropylene

Voltage

ECQ Type	ECQG ECQV Type	ECSZ Type	Others		
1H:50V	05:50V	0F:3.15V	0J :6.3V	1V :35V	
2A:100V	1:100V	1A:10V	1A :10V	50,1H:50V	
2E:250V	2:200V	1V:35V	1C :16V	1J :63V	
2H:500V		0J:6.3V	1E,25:25V	2A :100V	

13.1. CABINET AND ELECTRICAL PARTS LOCATION

Ref. No.	Part No.	Part Name & Description	Remarks
1	PQDF996Z	SHAFT	
2	PQHR10005Z	SPACER	
3	PQUB14Z2	LEVER	S
4	PSHD1088Z	SCREW	
5	PSMH1218Y	ANGLE	
6	PSHR1238Z	SPACER	
7	PSUS1020Z	TORSION SPRING	
8	PSUS1021Y	TORSION SPRING	
9	XUC25VW	RETAINING RING	

13.2. ACCESSORIES AND PACKING MATERIALS

Ref. No.	Part No.	Part Name & Description	Remarks
P1	PSPD1188Y	CUSHION	S
P2	PSPPI069Z	PROTECTION COVER	
P3	PSZKTDA0187M	GIFT BOX	

13.3. MAIN BOARD PARTS

Ref. No.	Part No.	Part Name & Description	Remarks
		(ICS)	
IC1	PFVI7020VX12	IC	
IC2	C1CB00001430	IC	
IC3	C3BBKG000060	IC	
IC5	PSWITDA0187X	IC	
IC6	PSVIPST596CN	IC	
IC7	C1CB00001497	IC	
IC20	PSVISNLV74AP	IC	S
IC21	C0JBAZ001610	IC	
IC22	C0JBAZ001401	IC	
IC23	C0JBAB000507	IC	
IC24	PSVITC7VC32T	IC	S
IC26	C0JBAZ001704	IC	S
IC28	PFVITC74V00T	IC	S
IC29	C0JBAB000504	IC	
IC30	PSVISNLV74AP	IC	S
IC31	PSVITC7VC32T	IC	S
IC302	PSVIMT9074AL	IC	S
IC303	PSVI320V542P	IC	S
IC304	C1CB00001181	IC	
IC501	PQVIS8520F33	IC	S
IC502	C0DBAHA00011	IC	
IC503	C0CBCAC00010	IC	
		(TRANSISTORS)	
Q1	PQVTDTA114EU	TRANSISTOR (SI)	S
Q2	PQVTDTA114EU	TRANSISTOR (SI)	S
Q3	PQVTDTA114EU	TRANSISTOR (SI)	S
Q4	PQVTDTA114EU	TRANSISTOR (SI)	S
Q6	PQVTDTA114EU	TRANSISTOR (SI)	S
Q7	PQVTDTA114EU	TRANSISTOR (SI)	S
Q8	PQVTDTA114EU	TRANSISTOR (SI)	S
Q12	PQVTDTC143E	TRANSISTOR (SI)	S
Q13	B1DFDC000002	TRANSISTOR (SI)	
Q301	PFVTMUN5232	TRANSISTOR (SI)	S
Q302	PFVTMUN5232	TRANSISTOR (SI)	S
Q503	B1DHCD000018	TRANSISTOR (SI)	
Q504	B1DHCD000018	TRANSISTOR (SI)	
		(DIODES)	
D1	PQVDBRKY1204	LED	S
D2	PSVD1SRCT	DIODE (SI)	S
D3	PSVD1SRCT	DIODE (SI)	S
D4	PSVD1SRCT	DIODE (SI)	S
D5	PSVD1VGCT	DIODE (SI)	S
D313	PSVDDALC208	DIODE (SI)	
D314	MA2J11100L	DIODE (SI)	
D315	MA2J11100L	DIODE (SI)	
D502	PFVDDGD1FP3T	DIODE (SI)	S
D503	PFVDDGD1FP3T	DIODE (SI)	S
D509	MA8075	DIODE (SI)	S
D510	MA8051	DIODE (SI)	S
DA501	MA142WRTX	DIODE (SI)	S
		(COILS)	
FIL301	PSLE1034	COIL	S
L501	G0C680KA0052	COIL	
L503	G0C680KA0052	COIL	
		(CONNECTORS)	
CN1	K1KA90B00008	CONNECTOR	
CN3	PSJP07A44Z	CONNECTOR	

Ref. No.	Part No.	Part Name & Description	Remarks
		(JACKS)	
CN4	PSJJ1T002Z	JACK	S
		(CRYSTAL OSCILLATIONS)	
X2	PSVCC0025GT	CRYSTAL OSCILLATOR	S
X5	HOJ200500030	CRYSTAL OSCILLATOR	
X6	HOJ100500018	CRYSTAL OSCILLATOR	
		(FUSE)	
IP1	K5H502Z00003	FUSE	
IP501	K5H751Z00003	FUSE	
IP502	K5H751Z00003	FUSE	
		(VARISTORS)	
SA301	PFRZRA311P6T	VARIATOR (SURGE ABSORBER)	S
SA302	PFRZRA311P6T	VARIATOR (SURGE ABSORBER)	S
SA303	PFRZRA102P6T	VARIATOR (SURGE ABSORBER)	△ S
SA304	PFRZRA102P6T	VARIATOR (SURGE ABSORBER)	△ S
SA305	PFRZRA311P6T	VARIATOR (SURGE ABSORBER)	S
SA306	PFRZRA311P6T	VARIATOR (SURGE ABSORBER)	S
		(FILTERS)	
FIL1	JOHAAH000003	IC FILTER	
FIL2	JOHAAH000003	IC FILTER	
FIL3	JOHAAH000020	IC FILTER	
FIL4	JOHAAH000020	IC FILTER	
FIL5	JOHAAH000003	IC FILTER	
FIL6	JOHAAH000003	IC FILTER	
FIL7	JOHAAH000020	IC FILTER	
FIL8	JOHAAH000003	IC FILTER	
FIL9	JOHAAH000020	IC FILTER	
FIL10	JOHAAH000003	IC FILTER	
FIL11	JOHAAH000003	IC FILTER	
FIL12	JOHAAH000020	IC FILTER	
FIL13	JOHAAH000003	IC FILTER	
FIL14	JOHAAH000003	IC FILTER	
FIL15	JOHAAH000020	IC FILTER	
FIL16	JOHAAH000003	IC FILTER	
FIL305	JOHAAH000003	IC FILTER	
FIL307	JOHAAH000003	IC FILTER	
FIL308	JOHAAH000003	IC FILTER	
FIL310	JOHAAH000020	IC FILTER	
FIL311	JOHAAH000020	IC FILTER	
FIL314	JOHAAH000003	IC FILTER	
FIL315	JOHAAH000003	IC FILTER	
L1	PFVFB221SB	CERAMIC FILTER	
L2	PFVFB221SB	CERAMIC FILTER	
L3	PFVFB221SB	CERAMIC FILTER	
L4	PFVFB221SB	CERAMIC FILTER	
L5	PFVFB221SB	CERAMIC FILTER	
L6	PFVFB221SB	CERAMIC FILTER	
L7	PFVFB221SB	CERAMIC FILTER	
L8	PFVFB221SB	CERAMIC FILTER	
L9	PFVFB221SB	CERAMIC FILTER	
L10	PFVFB221SB	CERAMIC FILTER	
L11	PFVFB221SB	CERAMIC FILTER	
L12	PFVFB221SB	CERAMIC FILTER	
L13	PFVFB221SB	CERAMIC FILTER	
L14	PFVFB221SB	CERAMIC FILTER	
L15	PFVFB221SB	CERAMIC FILTER	
L16	PFVFB221SB	CERAMIC FILTER	
L17	PFVFB221SB	CERAMIC FILTER	
L18	PFVFB221SB	CERAMIC FILTER	
L19	PFVFB221SB	CERAMIC FILTER	
L20	PFVFB221SB	CERAMIC FILTER	
L21	PFVFB221SB	CERAMIC FILTER	
L22	PFVFB221SB	CERAMIC FILTER	
L23	PFVFB221SB	CERAMIC FILTER	
L24	PFVFB221SB	CERAMIC FILTER	
L25	PFVFB221SB	CERAMIC FILTER	
L26	PFVFB221SB	CERAMIC FILTER	
L27	PFVFB221SB	CERAMIC FILTER	
L28	PFVFB221SB	CERAMIC FILTER	
L29	PFVFB221SB	CERAMIC FILTER	
L30	PFVFB221SB	CERAMIC FILTER	
L31	PFVFB221SB	CERAMIC FILTER	
L32	PFVFB221SB	CERAMIC FILTER	

Ref. No.	Part No.	Part Name & Description	Remarks
L33	PFVFB221SB	CERAMIC FILTER	
L34	PFVFB221SB	CERAMIC FILTER	
L35	PFVFB221SB	CERAMIC FILTER	
L36	PFVFB221SB	CERAMIC FILTER	
L37	PFVFB221SB	CERAMIC FILTER	
L38	PFVFB221SB	CERAMIC FILTER	
L39	PFVFB221SB	CERAMIC FILTER	
L40	PFVFB221SB	CERAMIC FILTER	
L41	PFVFB221SB	CERAMIC FILTER	
L43	PFVFB221SB	CERAMIC FILTER	
L44	PFVFB221SB	CERAMIC FILTER	
L45	PFVFB221SB	CERAMIC FILTER	
L46	PFVFB221SB	CERAMIC FILTER	
L47	PFVFB221SB	CERAMIC FILTER	
L55	PFVFB221SB	CERAMIC FILTER	
L56	PFVFB221SB	CERAMIC FILTER	
L57	PFVFB221SB	CERAMIC FILTER	
L58	PFVFB221SB	CERAMIC FILTER	
L59	PFVFB221SB	CERAMIC FILTER	
L60	PFVFB221SB	CERAMIC FILTER	
L61	PFVFB221SB	CERAMIC FILTER	
L62	PFVFB221SB	CERAMIC FILTER	
L63	PFVFB221SB	CERAMIC FILTER	
L64	PFVFB221SB	CERAMIC FILTER	
L65	PFVFB221SB	CERAMIC FILTER	
L66	PFVFB221SB	CERAMIC FILTER	
L67	PFVFB221SB	CERAMIC FILTER	
L68	PFVFB221SB	CERAMIC FILTER	
L69	PFVFB221SB	CERAMIC FILTER	
L70	PFVFB221SB	CERAMIC FILTER	
L71	PFVFB221SB	CERAMIC FILTER	
L72	PFVFB221SB	CERAMIC FILTER	
L73	PFVFB221SB	CERAMIC FILTER	
L74	PFVFB221SB	CERAMIC FILTER	
L75	PFVFB221SB	CERAMIC FILTER	
L76	PFVFB221SB	CERAMIC FILTER	
L77	PFVFB221SB	CERAMIC FILTER	
L78	PFVFB221SB	CERAMIC FILTER	
L79	PFVFB221SB	CERAMIC FILTER	
L81	PFVFB221SB	CERAMIC FILTER	
L303	PFVFB221SB	CERAMIC FILTER	
L304	PFVFB221SB	CERAMIC FILTER	
L506	PFVFB221SB	CERAMIC FILTER	
L507	PFVFB221SB	CERAMIC FILTER	
X1	H2D122500003	CERAMIC FILTER	
		(COMPONENT PARTS)	
T303	PSLT9Z17A	TRANSFORMER	△ S
T304	PSLT9Z16A	TRANSFORMER	△ S
		(SWITCH)	
SW302	K0D148A00001	SLIDE SWITCH	
		(RELAY)	
RL301	K6B2CGA00094	RELAY	△
RL302	K6B2CGA00094	RELAY	△
		(COMPONENTS PARTS)	
RA1	EXB38V680JV	RESISTOR ARRAY, 68K	
RA2	EXB38V680JV	RESISTOR ARRAY, 68K	
RA3	EXB38V680JV	RESISTOR ARRAY, 68K	
RA4	EXB38V680JV	RESISTOR ARRAY, 68K	
RA5	EXB38V680JV	RESISTOR ARRAY, 68K	
RA6	EXB38V680JV	RESISTOR ARRAY, 68K	
RA7	EXB38V680JV	RESISTOR ARRAY, 68K	
RA8	EXB38V680JV	RESISTOR ARRAY, 68K	
RA9	EXB38V680JV	RESISTOR ARRAY, 68K	
RA10	D1HA1028A005	RESISTOR ARRAY, 1K	
RA11	D1HA1028A005	RESISTOR ARRAY, 1K	
RA12	D1HA1028A005	RESISTOR ARRAY, 1K	
RA13	D1HA1028A005	RESISTOR ARRAY, 1K	
RA16	D1HA1038A005	RESISTOR ARRAY, 10K	
RA17	D1HA1028A005	RESISTOR ARRAY, 1K	
RA18	D1HA1028A005	RESISTOR ARRAY, 1K	
RA19	EXB38V220JV	RESISTOR ARRAY, 22	
RA20	EXB38V220JV	RESISTOR ARRAY, 22	
RA21	D1HA1038A005	RESISTOR ARRAY, 10K	

Ref. No.	Part No.	Part Name & Description	Remarks
RA25	D1HA1038A005	RESISTOR ARRAY, 10K	
RA26	D1HA1028A005	RESISTOR ARRAY, 1K	
RA27	D1HA1038A005	RESISTOR ARRAY, 10K	
RA28	D1HA1038A005	RESISTOR ARRAY, 10K	
RA35	D1HA1038A005	RESISTOR ARRAY, 10K	
RA40	D1HA1038A005	RESISTOR ARRAY, 10K	
RA301	D1HA1038A005	RESISTOR ARRAY, 10K	
RA302	D1HA1038A005	RESISTOR ARRAY, 10K	
RA304	EXB38V220JV	RESISTOR ARRAY, 22	
RA305	EXB38V220JV	RESISTOR ARRAY, 22	
		(RESISTOR)	
J3	ERJ3GEY0R00	0	
J4	ERJ3GEY0R00	0	
J28	ERJ3GEY0R00	0	
J30	ERJ3GEY0R00	0	
J31	ERJ3GEY0R00	0	
J32	ERJ3GEY0R00	0	
J33	ERJ3GEY0R00	0	
J40	ERJ3GEY0R00	0	
J42	ERJ3GEY0R00	0	
J46	ERJ3GEY0R00	0	
J301	ERJ3GEY0R00	0	
J302	ERJ3GEY0R00	0	
J323	PQ4R18XJ000	0	S
J324	PQ4R18XJ000	0	S
L48	ERJ3GEY0R00	0	
L84	PQ4R10XJ000	0	S
L85	PQ4R10XJ000	0	S
L86	PQ4R10XJ000	0	S
L87	PQ4R10XJ000	0	S
L88	PQ4R10XJ000	0	S
L89	PQ4R10XJ000	0	S
L90	PQ4R10XJ000	0	S
L91	PQ4R10XJ000	0	S
L92	PQ4R10XJ000	0	S
L93	PQ4R10XJ000	0	S
L301	ERJ3GEY0R00	0	
L308	PQ4R10XJ000	0	S
L309	PQ4R10XJ000	0	S
L310	PQ4R10XJ000	0	S
L311	PQ4R10XJ000	0	S
L313	PQ4R10XJ000	0	S
L502	PQ4R18XJ000	0	S
L504	PQ4R18XJ000	0	S
R1	ERJ3GEYJ103	10K	
R2	ERJ3GEYJ103	10K	
R3	ERJ3GEYJ103	10K	
R4	ERJ3GEYJ103	10K	
R5	ERJ3GEYJ103	10K	
R6	ERJ3GEYJ220	22	
R7	ERJ3GEYJ103	10K	
R8	ERJ3GEYJ220	22	
R9	ERJ3GEYJ220	22	
R10	ERJ3GEYJ151	150	
R11	ERJ3GEYJ680	68	
R12	ERJ3GEYJ103	10K	
R13	ERJ3GEYJ103	10K	
R14	ERJ3GEYJ220	22	
R15	ERJ3GEYJ103	10K	
R16	ERJ3GEYJ220	22	
R17	ERJ3GEYJ102	1K	
R18	ERJ3GEYJ680	68	
R19	ERJ3GEYJ680	68	
R20	ERJ3GEYJ103	10K	
R21	ERJ3GEYJ101	100	
R24	ERJ3GEYJ220	22	
R25	ERJ3GEYJ151	150	
R26	ERJ3GEYJ151	150	
R27	ERJ3GEYJ101	100	
R29	ERJ3GEYJ680	68	
R30	ERJ3GEYJ151	150	
R31	ERJ3GEYJ103	10K	
R32	ERJ3GEYJ103	10K	

Ref. No.	Part No.	Part Name & Description	Remarks
R33	ERJ3GEYJ103	10K	
R34	ERJ3GEYJ103	10K	
R35	ERJ3GEYJ680	68	
R38	ERJ3GEYJ220	22	
R39	ERJ3GEYJ151	150	
R40	ERJ3GEYJ151	150	
R41	ERJ3GEYJ220	22	
R42	ERJ3GEYJ220	22	
R43	ERJ3GEYJ151	150	
R44	ERJ3GEYJ151	150	
R45	ERJ3GEYJ220	22	
R46	ERJ3GEYJ151	150	
R47	ERJ3GEYJ151	150	
R49	ERJ3GEYJ102	1K	
R53	ERJ3GEYJ102	1K	
R54	ERJ3GEYJ102	1K	
R55	ERJ3GEYJ102	1K	
R56	ERJ3GEYJ102	1K	
R57	ERJ3GEYJ102	1K	
R58	ERJ3GEYJ102	1K	
R59	ERJ3GEYJ102	1K	
R60	ERJ3GEYJ102	1K	
R73	ERJ3GEYJ220	22	
R74	ERJ3GEY0R00	0	
R75	ERJ3GEYJ103	10K	
R76	ERJ3GEYJ103	10K	
R79	ERJ3GEYJ220	22	
R87	ERJ3GEYJ220	22	
R88	ERJ3GEYJ103	10K	
R89	ERJ3GEYJ103	10K	
R90	ERJ3GEYJ102	1K	
R91	ERJ3GEYJ103	10K	
R92	ERJ3GEYJ102	1K	
R93	ERJ3GEYJ102	1K	
R94	ERJ3GEYJ220	22	
R95	ERJ3GEYJ470	47	
R97	ERJ3GEYJ102	1K	
R98	ERJ3GEYJ105	1M	
R99	ERJ3GEYJ122	1.2K	
R100	ERJ3GEYJ151	150	
R102	ERJ3GEYJ102	1K	
R103	ERJ3GEYJ102	1K	
R104	ERJ3GEYJ102	1K	
R105	ERJ3GEYJ470	47	
R106	ERJ3GEYJ470	47	
R107	ERJ3GEYJ103	10K	
R110	ERJ3GEYJ470	47	
R111	ERJ3GEYJ470	47	
R112	ERJ3GEYJ470	47	
R113	ERJ3GEYJ470	47	
R114	ERJ3GEYJ102	1K	
R116	ERJ3GEYJ470	47	
R117	ERJ3GEYJ103	10K	
R118	ERJ3GEYJ103	10K	
R119	ERJ3GEYJ103	10K	
R122	ERJ3GEYJ103	10K	
R123	ERJ3GEYJ220	22	
R124	ERJ3GEYJ220	22	
R125	ERJ3GEYJ220	22	
R126	ERJ3GEYJ220	22	
R127	ERJ3GEYJ220	22	
R128	ERJ3GEYJ221	220	
R129	ERJ3GEYJ220	22	
R130	ERJ3GEYJ220	22	
R131	ERJ3GEYJ103	10K	
R132	ERJ3GEYJ102	1K	
R133	ERJ3GEYJ103	10K	
R134	ERJ3GEYJ103	10K	
R135	ERJ3GEYJ103	10K	
R136	ERJ3GEYJ103	10K	
R137	ERJ3GEYJ103	10K	
R138	ERJ3GEYJ102	1K	
R139	ERJ3GEYJ103	10K	

Ref. No.	Part No.	Part Name & Description	Remarks
R140	ERJ3GEYJ102	1K	
R141	ERJ3GEYJ102	1K	
R142	ERJ3GEYJ470	47	
R143	ERJ3GEYJ102	1K	
R144	ERJ3GEYJ220	22	
R145	ERJ3GEYJ220	22	
R146	ERJ3GEYJ103	10K	
R147	ERJ3GEYJ220	22	
R148	ERJ3GEYJ220	22	
R149	ERJ3GEYJ220	22	
R150	ERJ3GEYJ102	1K	
R153	ERJ3GEYJ470	47	
R154	ERJ3GEYJ470	47	
R155	ERJ3GEYJ470	47	
R156	ERJ3GEYJ470	47	
R157	ERJ3GEYJ470	47	
R158	ERJ3GEYJ470	47	
R159	ERJ3GEYJ470	47	
R160	ERJ3GEYJ470	47	
R161	ERJ3GEYJ470	47	
R162	ERJ3GEYJ470	47	
R163	ERJ3GEYJ470	47	
R164	ERJ3GEYJ470	47	
R165	ERJ3GEYJ470	47	
R166	ERJ3GEYJ470	47	
R167	ERJ3GEYJ470	47	
R168	ERJ3GEYJ470	47	
R169	ERJ3GEYJ470	47	
R170	ERJ3GEYJ470	47	
R171	ERJ3GEYJ470	47	
R172	ERJ3GEYJ470	47	
R173	ERJ3GEYJ470	47	
R174	ERJ3GEYJ470	47	
R175	ERJ3GEYJ470	47	
R176	ERJ3GEYJ470	47	
R177	ERJ3GEYJ151	150	
R178	ERJ3GEYJ103	10K	
R179	ERJ3GEYJ103	10K	
R314	ERJ6GEYJ2R4	2.4	
R315	ERJ6GEYJ2R4	2.4	
R316	ERJ3GEY0R00	0	
R317	ERJ3GEY0R00	0	
R318	ERJ3GEYJ103	10K	
R319	ERJ3GEYJ103	10K	
R320	ERJ3GEYJ103	10K	
R321	ERJ3GEYJ103	10K	
R322	ERJ3GEYJ102	1K	
R325	ERJ3GEYJ103	10K	
R327	ERJ3GEYJ180	18	
R328	ERJ3GEYJ103	10K	
R331	PQ4R10XJ101	100	S
R332	ERJ3GEYJ105	1M	
R335	ERJ3GEYJ220	22	
R337	ERJ3GEYJ680	68	
R338	ERJ3GEYJ220	22	
R340	ERJ3GEYJ103	10K	
R341	ERJ3GEYJ220	22	
R342	ERJ3GEYJ103	10K	
R343	ERJ3GEYJ103	10K	
R346	ERJ3GEYJ221	220	
R351	ERJ3GEYJ102	1K	
R352	ERJ3GEYJ102	1K	
R354	ERJ3GEYJ103	10K	
R355	ERJ3GEYJ103	10K	
R356	ERJ3GEYJ103	10K	
R357	ERJ3GEYJ103	10K	
R358	ERJ3GEY0R00	0	
R359	ERJ3GEYJ102	1K	
R360	ERJ3GEYJ103	10K	
R361	ERJ3GEYJ102	1K	
R362	ERJ3GEYJ103	10K	
R363	ERJ3GEYJ103	10K	
R364	ERJ3GEYJ103	10K	

Ref. No.	Part No.	Part Name & Description	Remarks
R365	ERJ3GEYJ103	10K	
R367	ERJ3GEYJ103	10K	
R368	ERJ3GEYJ103	10K	
R369	ERJ3GEYJ221	220	
R370	ERJ3GEYJ220	22	
R371	ERJ3GEYJ220	22	
R372	ERJ3GEYJ220	22	
R373	ERJ3GEYJ103	10K	
R374	ERJ3GEYJ103	10K	
R375	ERJ3GEYJ103	10K	
R376	PQ4R10XJ221	220	S
R377	ERJ3GEYJ102	1K	
R378	PQ4R10XJ221	220	S
R379	ERJ3GEYJ103	10K	
R380	ERJ3GEYJ102	1K	
R381	ERJ3GEYJ102	1K	
R382	ERJ3GEY0R00	0	
R383	ERJ3GEY0R00	0	
R384	ERJ3GEYJ103	10K	
R385	ERJ3GEYJ103	10K	
R386	ERJ3GEYJ103	10K	
R387	ERJ3GEYJ103	10K	
R501	ERJ3GEYJ681	680	
R502	ERJ3GEYJ681	680	
R503	ERJ3GEYJ681	680	
R504	ERJ3GEYJ560	56	
R505	ERJ3GEYJ560	56	
R506	ERJ3GEYJ681	680	
		(CAPACITORS)	
C1	PQCUV1A225ZF	2.2	
C2	ECUV1A105ZFFV	1	
C3	ECUV1C104KBV	0.1	
C4	ECUV1C104KBV	0.1	
C5	ECUV1C104KBV	0.1	
C6	ECUV1C104KBV	0.1	
C8	PQCUV1A225ZF	2.2	
C9	ECUV1A105ZFFV	1	
C10	ECUV1C104KBV	0.1	
C11	ECUV1H270JCV	27P	
C12	ECUV1H270JCV	27P	
C15	PQCUV1A225ZF	2.2	
C16	ECUV1A105ZFFV	1	
C17	ECUV1C104KBV	0.1	
C18	PQCUV1A225ZF	2.2	
C19	ECUV1A105ZFFV	1	
C20	ECUV1C104KBV	0.1	
C21	ECUV1C104KBV	0.1	
C22	ECUV1C104KBV	0.1	
C23	ECUV1C104KBV	0.1	
C24	ECUV1H150JCV	15P	
C25	ECUV1H150JCV	15P	
C27	ECUV1C104KBV	0.1	
C28	ECUV1C104KBV	0.1	
C30	PQCUV1A225ZF	2.2	
C31	ECUV1A105ZFFV	1	
C32	ECUV1C104KBV	0.1	
C33	ECUV1C104KBV	0.1	
C34	PQCUV1A225ZF	2.2	
C35	ECUV1A105ZFFV	1	
C38	ECUV1H103KBV	0.01	
C39	ECUV1H103KBV	0.01	
C40	ECUV1C104KBV	0.1	
C41	ECUV1C104KBV	0.1	
C42	ECUV1C104KBV	0.1	
C43	ECUV1C104KBV	0.1	
C44	ECUV1C104KBV	0.1	
C45	ECUV1C104KBV	0.1	
C46	PQCUV1A225ZF	2.2	
C47	ECUV1A105ZFFV	1	
C48	ECUV1C104KBV	0.1	
C49	ECUV1C104KBV	0.1	
C50	PQCUV1A225ZF	2.2	
C51	ECUV1A105ZFFV	1	

Ref. No.	Part No.	Part Name & Description	Remarks
C52	PQCUV1A225ZF	2.2	
C53	ECUV1A105ZFB	1	
C54	ECUV1C104KBV	0.1	
C55	ECUV1C104KBV	0.1	
C56	ECUV1C104KBV	0.1	
C57	ECUV1C104KBV	0.1	
C58	ECUV1H220JCV	22P	
C59	ECUV1H331JCV	330P	S
C60	ECUV1C104KBV	0.1	
C61	ECUV1H332KBV	0.0033	
C62	ECUV1C104KBV	0.1	
C63	ECUV1C104KBV	0.1	
C64	ECUV1C104KBV	0.1	
C65	ECUV1C104KBV	0.1	
C66	ECUV1C104KBV	0.1	
C67	ECUV1C104KBV	0.1	
C68	ECUV1C104KBV	0.1	
C69	ECUV1C104KBV	0.1	
C70	ECUV1C104KBV	0.1	
C71	ECUV1C104KBV	0.1	
C72	ECUV1C104KBV	0.1	
C73	ECUV1C104KBV	0.1	
C74	ECUV1C104KBV	0.1	
C75	ECUV1C104KBV	0.1	
C76	ECUV1C104KBV	0.1	
C77	ECUV1C104KBV	0.1	
C78	ECUV1C104KBV	0.1	
C79	ECUV1C104KBV	0.1	
C80	ECUV1C104KBV	0.1	
C81	ECUV1C104KBV	0.1	
C82	ECUV1C104KBV	0.1	
C83	ECUV1C104KBV	0.1	
C84	ECUV1C104KBV	0.1	
C85	ECUV1C104KBV	0.1	
C86	ECUV1C104KBV	0.1	
C87	ECUV1C104KBV	0.1	
C88	ECUV1C104KBV	0.1	
C89	ECUV1C104KBV	0.1	
C90	ECUV1C104KBV	0.1	
C91	ECUV1C104KBV	0.1	
C92	ECUV1C104KBV	0.1	
C93	ECUV1C104KBV	0.1	
C94	ECUV1C104KBV	0.1	
C95	ECUV1C104KBV	0.1	
C96	ECUV1C104KBV	0.1	
C97	ECUV1A105ZFB	1	
C98	PQCUV1A225ZF	2.2	
C301	PQCUV1C684ZF	0.68	S
C308	ECUV1H050CCV	5P	
C309	ECUV1H050CCV	5P	
C310	ECUV1A105ZFB	1	
C311	ECUV1C104KBV	0.1	
C312	PQCUV1A225ZF	2.2	
C313	ECUV1A105ZFB	1	
C314	ECUV1C104KBV	0.1	
C322	PQCUV1A225ZF	2.2	
C323	ECUV1A105ZFB	1	
C324	ECUV1C104KBV	0.1	
C325	PQCUV1A225ZF	2.2	
C326	ECUV1A105ZFB	1	
C327	ECUV1C104KBV	0.1	
C328	ECUV1H180JCV	18P	
C329	ECUV1H150JCV	15P	
C334	ECUV1A105ZFB	1	
C336	ECUV1C104KBV	0.1	
C337	ECUV1C104KBV	0.1	
C338	ECUV1C104KBV	0.1	
C339	ECJ1VC1H151J	150P	
C340	PQCUV1A225ZF	2.2	
C341	ECUV1C104KBV	0.1	
C344	ECUV1H330JCV	33P	
C345	ECUV1H330JCV	33P	
C346	ECUV1H330JCV	33P	

Ref. No.	Part No.	Part Name & Description	Remarks
C347	ECUV1H330JCV	33P	
C401	ECA1EHG470	47P	
C403	EEUFC1E101S	100P	
C404	EEUFC0J221	220P	
C405	EEUFC1E470	47P	
C406	EEUFC1A151	150P	
C501	ECUV1C104KBV	0.1	
C502	ECUV1C104KBV	0.1	
C503	ECUV1C104KBV	0.1	
C506	ECUV1C104KBV	0.1	
C507	ECUV1C104KBV	0.1	
C508	ECUV1A105ZFB	1	S
C509	ECUV1A105ZFB	1	S

14 FOR SCHEMATIC DIAGRAM

Note:

1. DC voltage measurements are taken with voltmeter from the negative voltage line.

Important Safety Notice:

Components identified by \triangle mark have special characteristics important for safety. When replacing any of these components, use only the manufacturer's specified parts.

2. This schematic diagram may be modified at any time with the development of new technology.

15 SCHEMATIC DIAGRAM

15.1. No.1

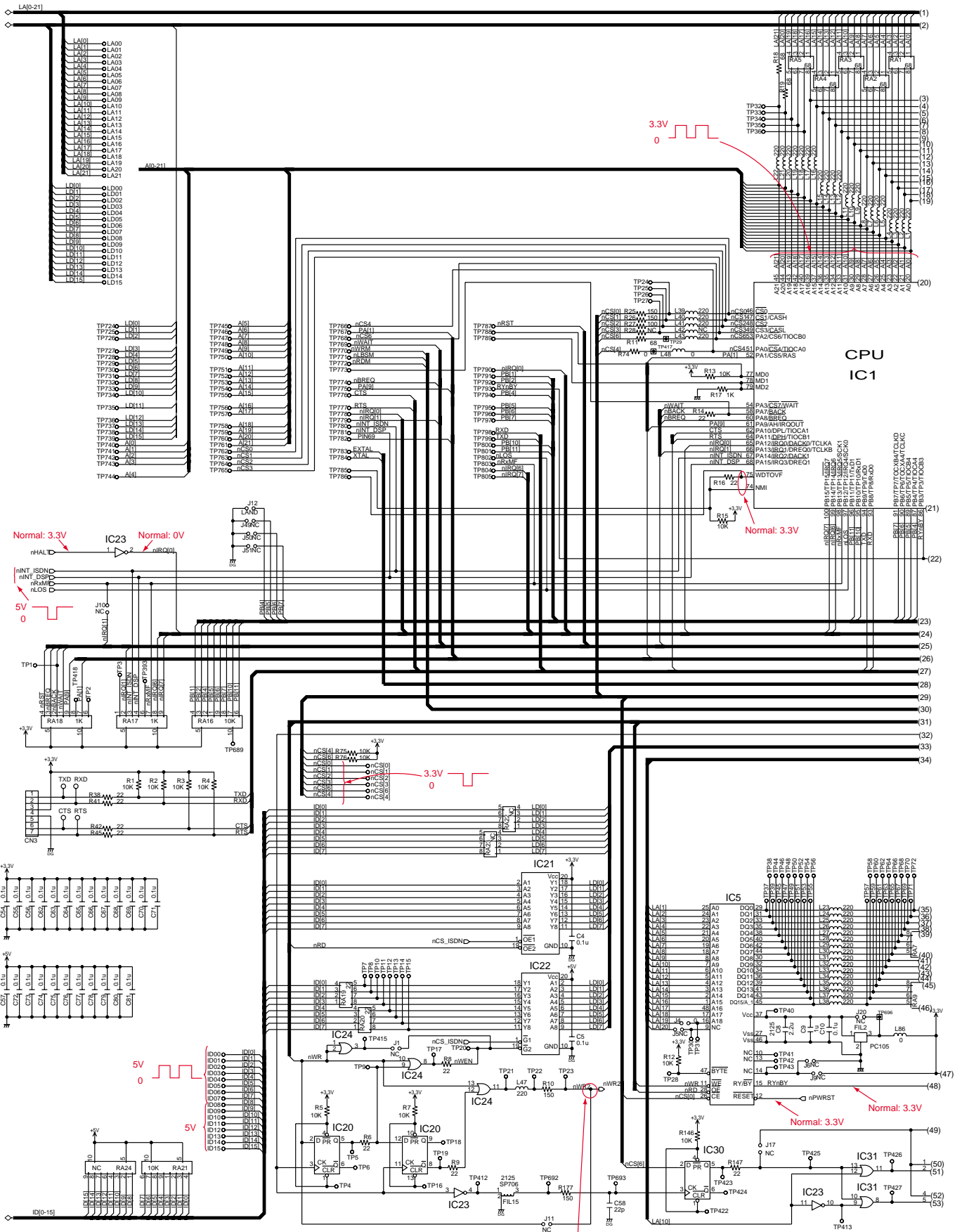

KX-TDA0187 SCHEMATIC DIAGRAM No.1

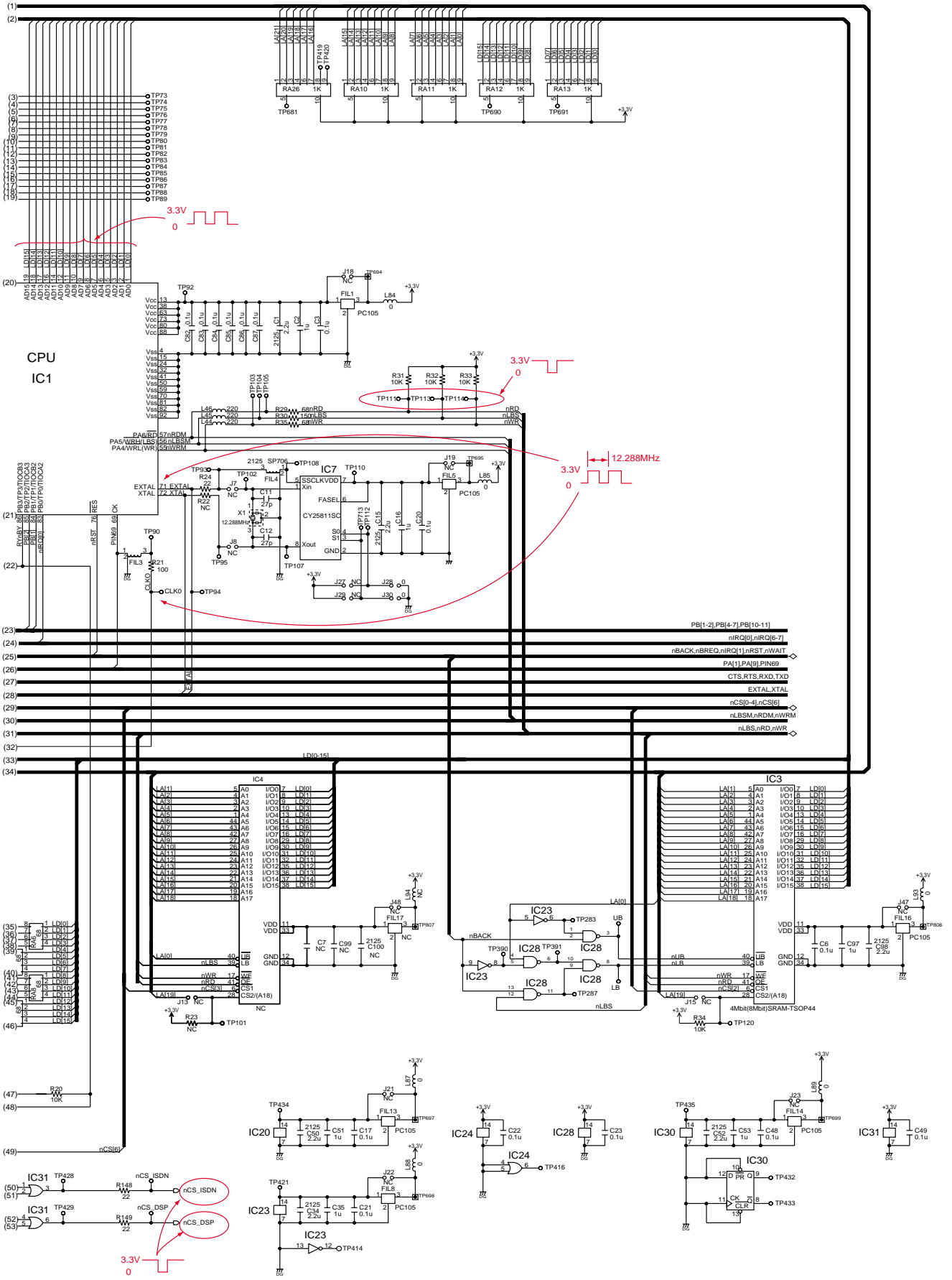

15.2. No.2

FAX TX Signal
 FAX RX Signal

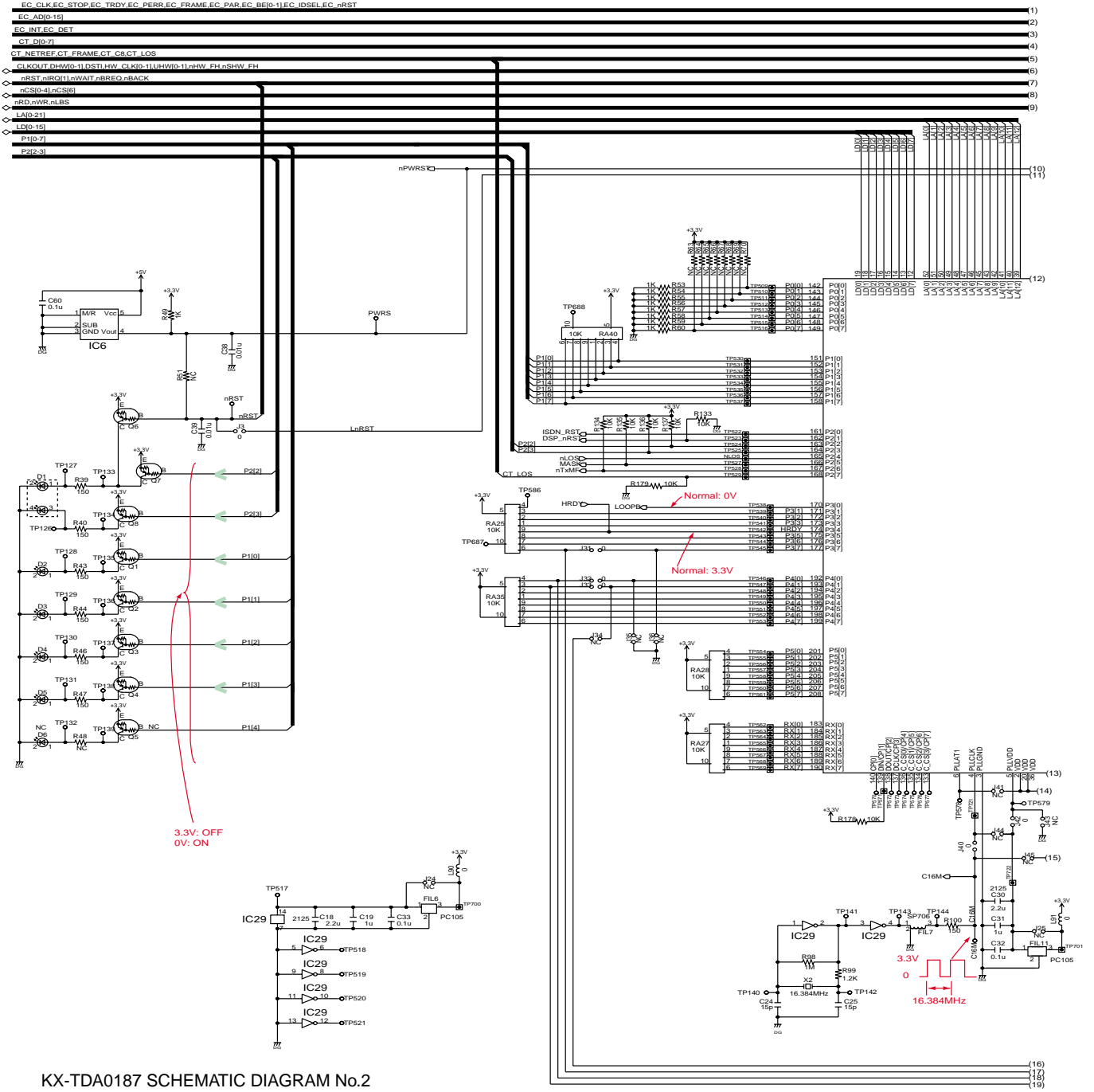

KX-TDA0187 SCHEMATIC DIAGRAM No.2

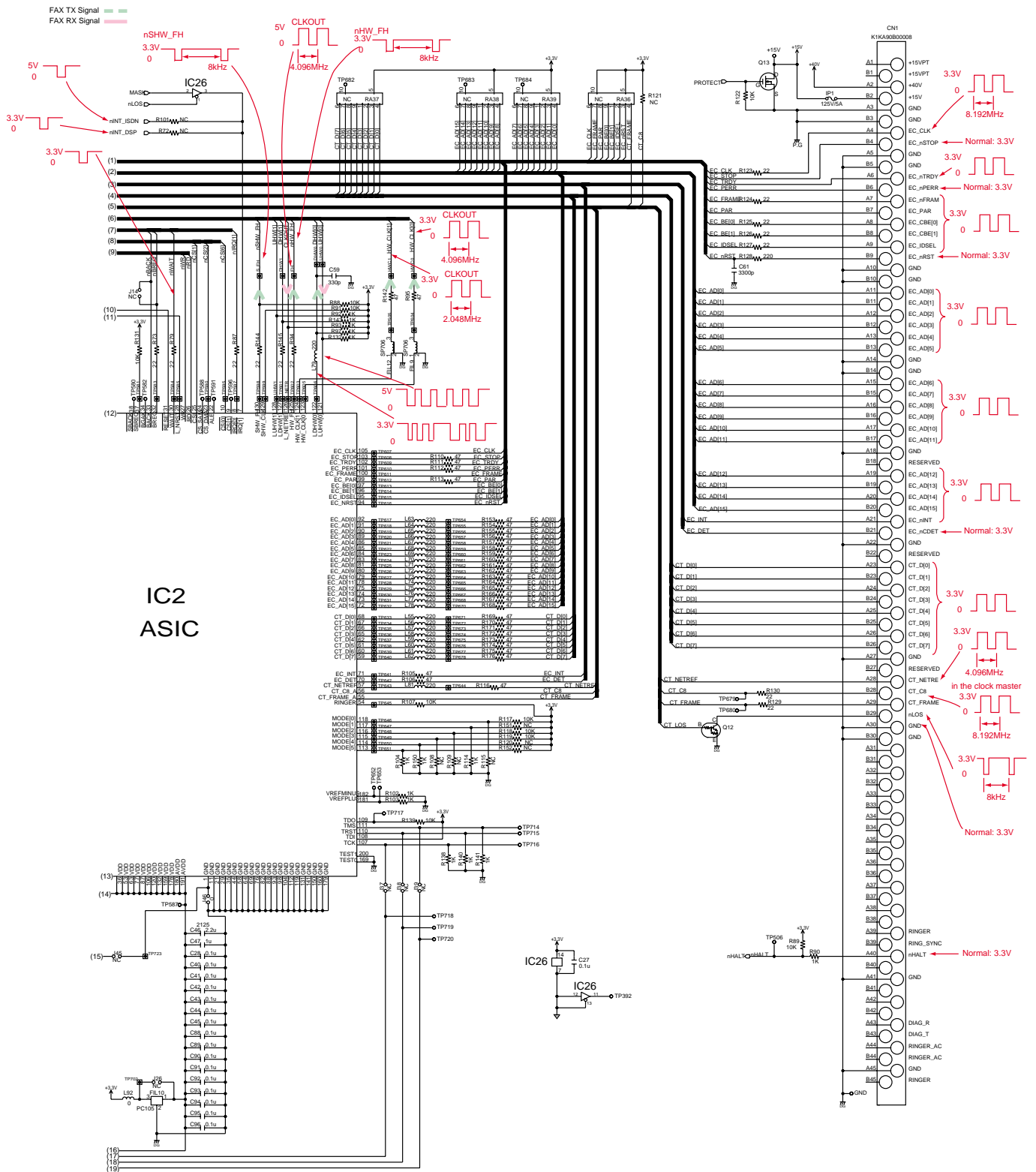

15.3. No.3

FAX TX Signal —
FAX RX Signal —

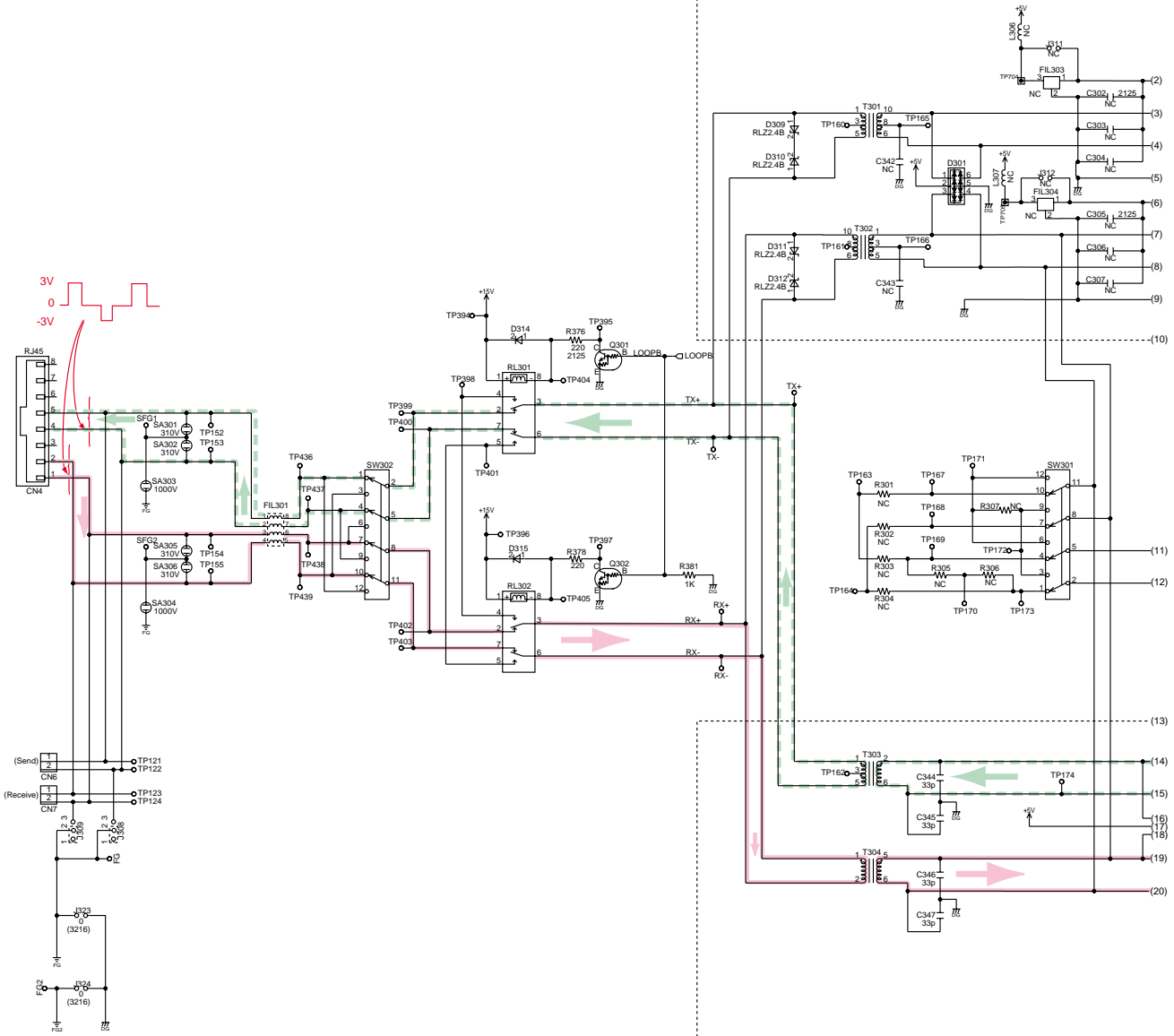

KX-TDA0187 SCHEMATIC DIAGRAM No.3

PRI Brock

E1/T1 Brock

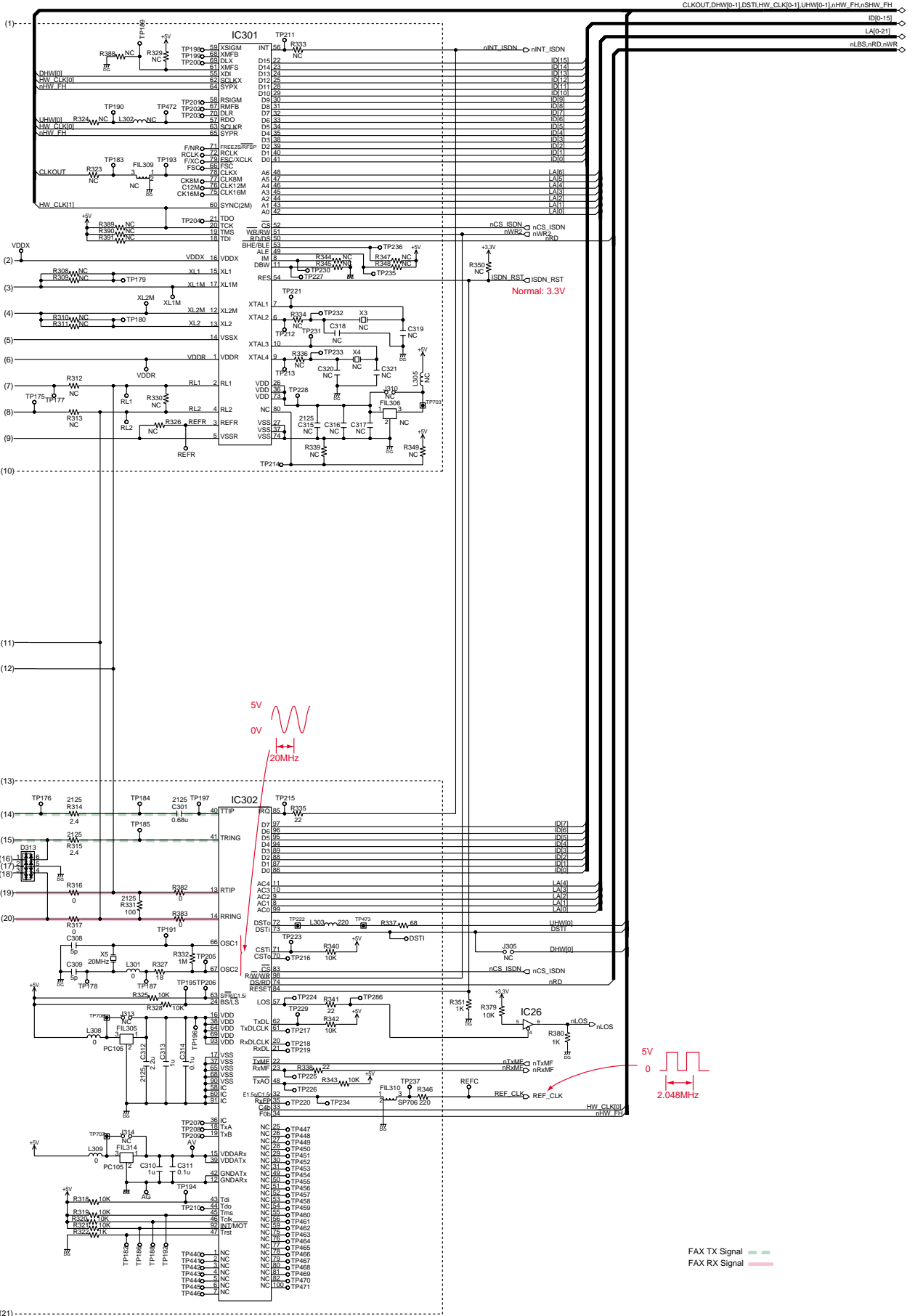

15.4. No.4

FAX TX Signal
FAX RX Signal

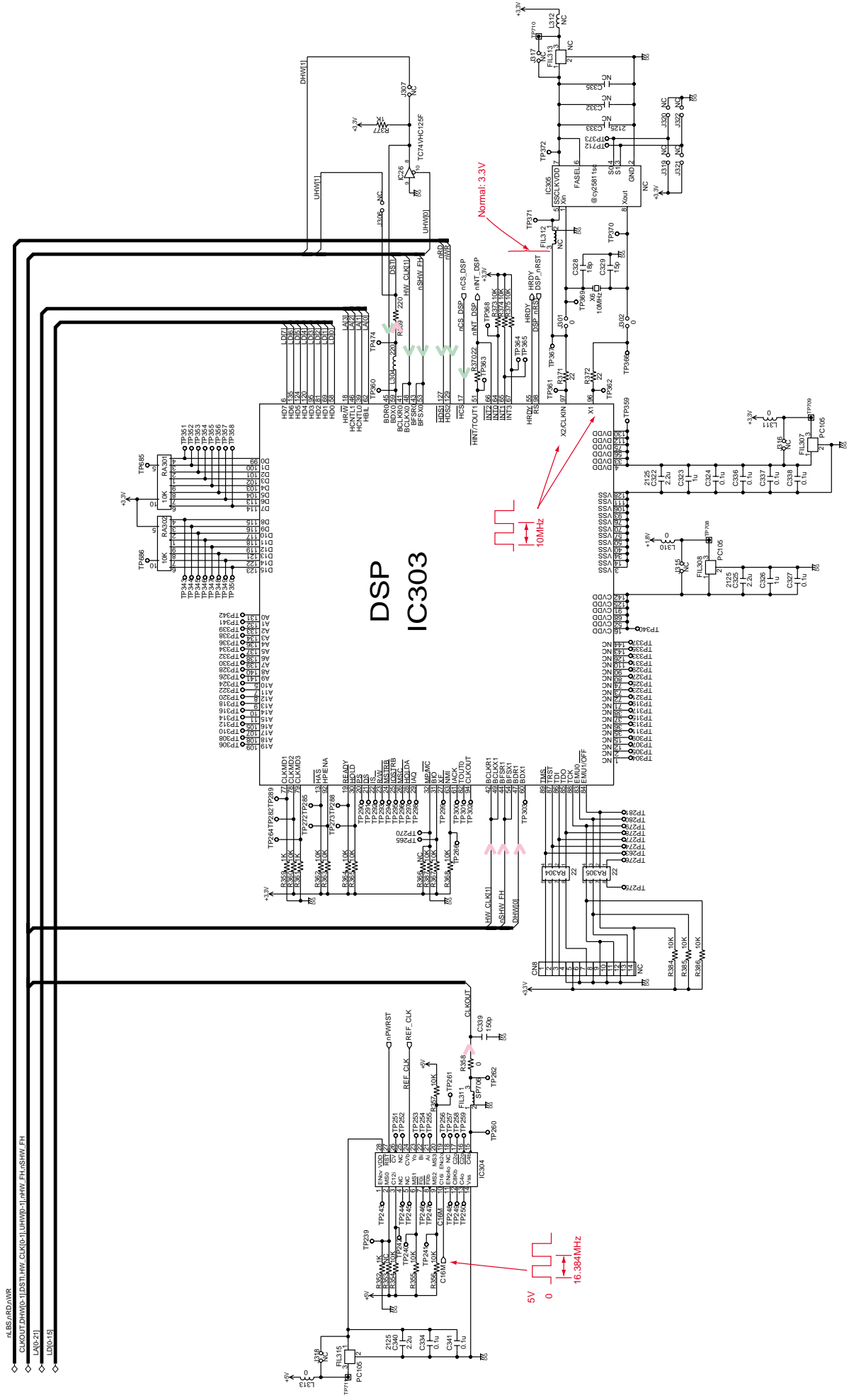

KX-TDA0187 SCHEMATIC DIAGRAM No.4

15.5. No.5

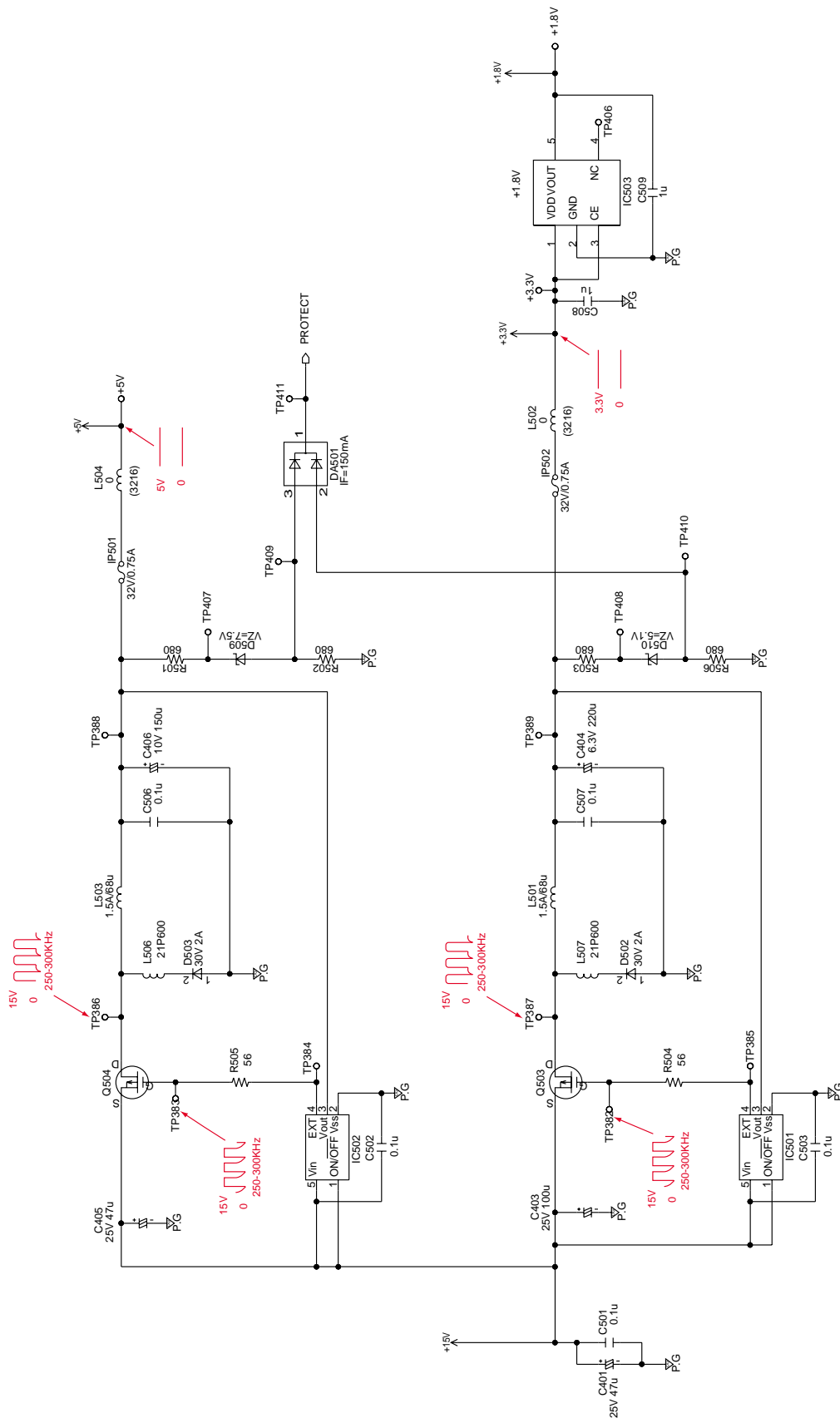

KX-TDA0187 SCHEMATIC DIAGRAM No.5

16 PRINTED CIRCUIT BOARD

16.1. COMPONENT VIEW

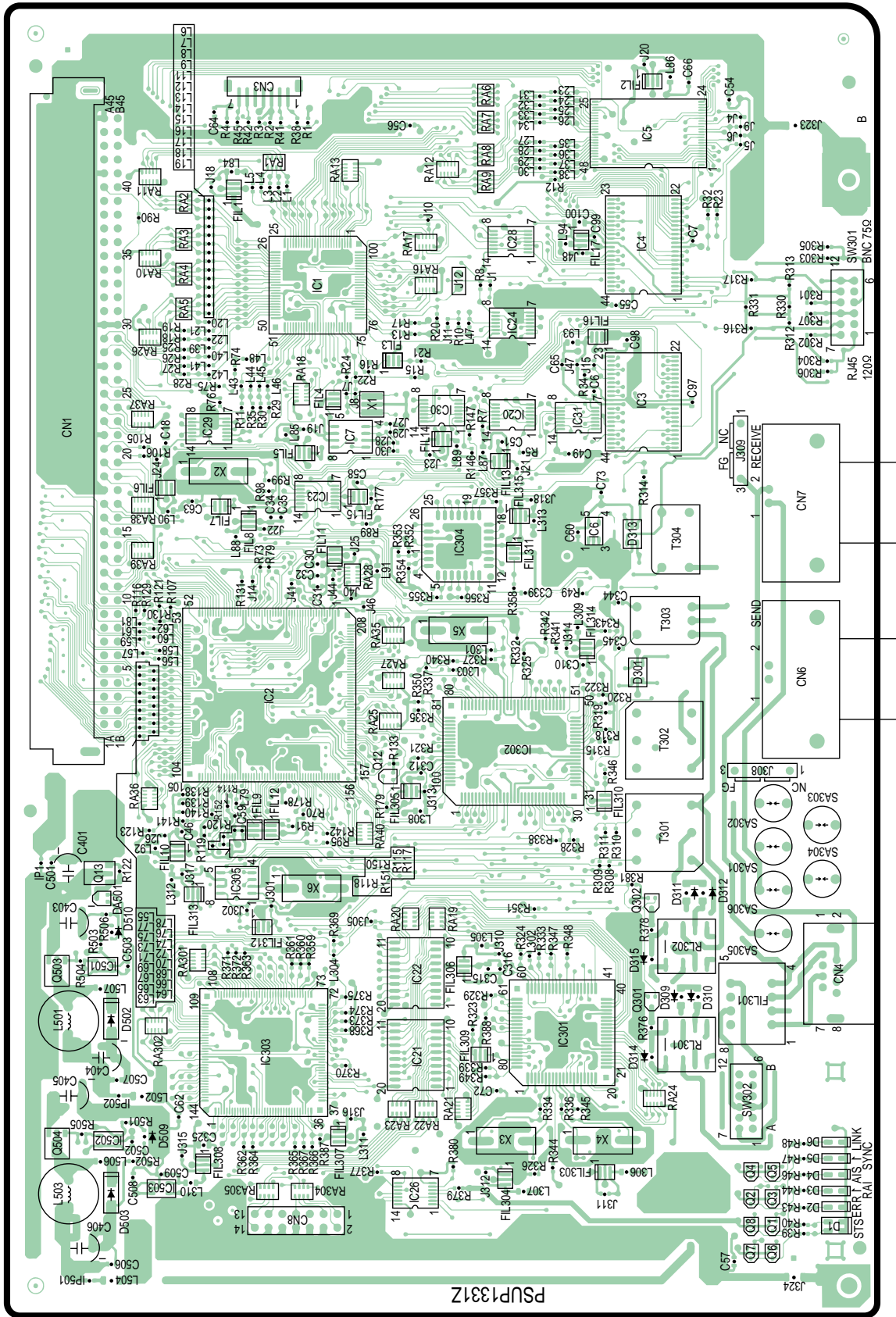

16.2. BOTTOM VIEW

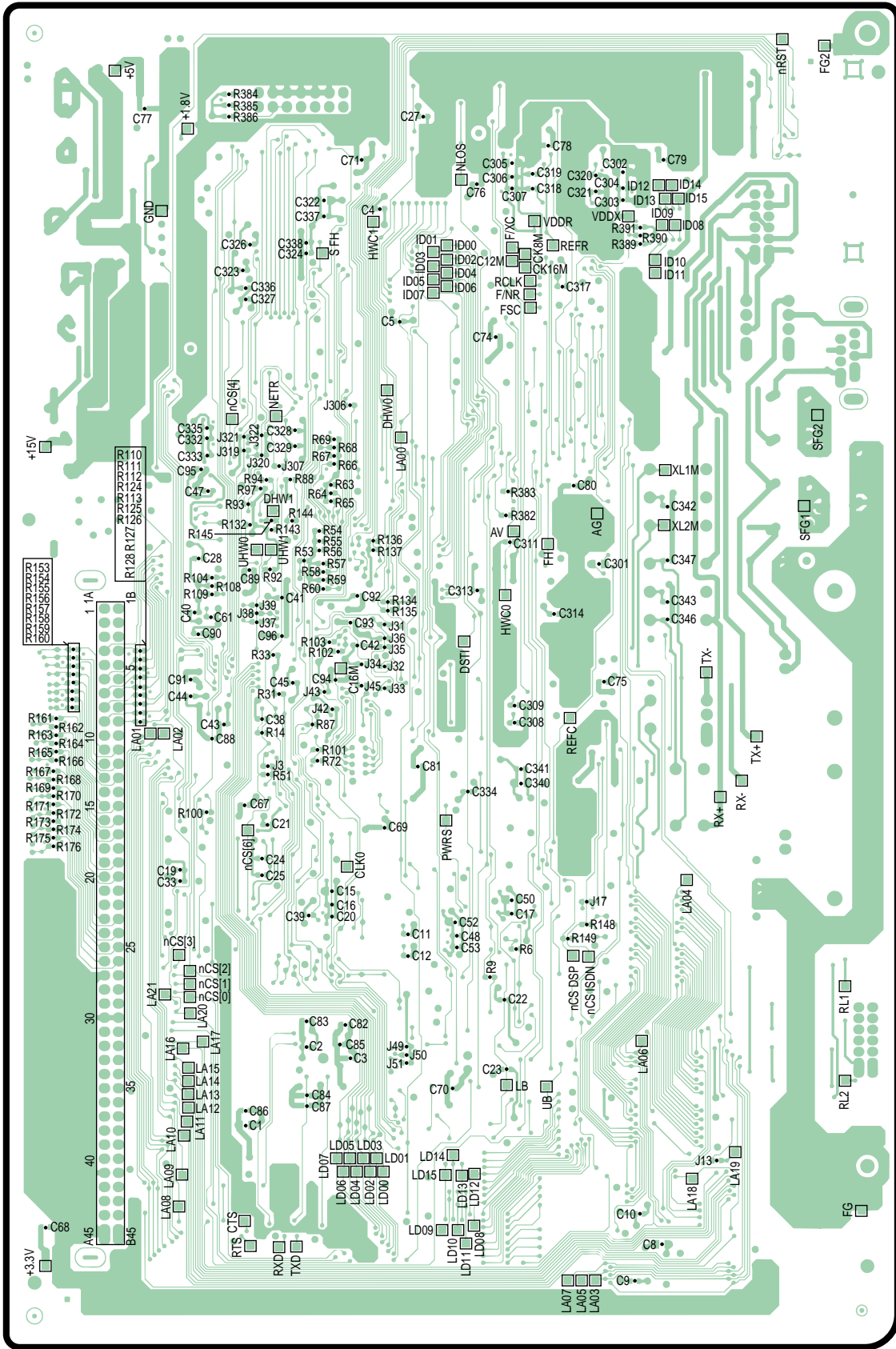

KX-TDA0187 BOTTOM VIEW

