

# Service Manual

Compact Plain Paper FAX and Copier

## KX-FP342BX

(for Asia, Middle Near East, Latin America, Africa,  
Russia and Europe)

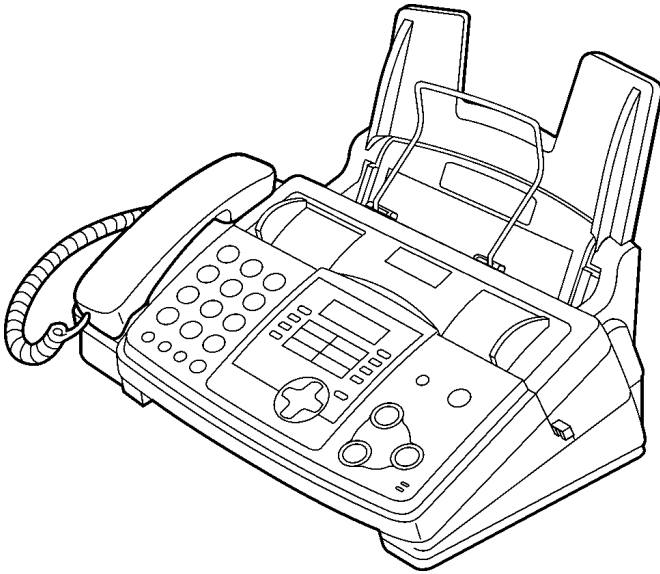

### **WARNING**

This service information is designed for experienced repair technicians only and is not designed for use by the general public. It does not contain warnings or cautions to advise non-technical individuals of potential dangers in attempting to service a product. Products powered by electricity should be serviced or repaired only by experienced professional technicians. Any attempt to service or repair the product or products dealt with in this service information by anyone else could result in serious injury or death.

When you note the serial number, write down all of the 11 digits. The serial number may be found on the bottom of the unit.

### **IMPORTANT INFORMATION ABOUT LEAD FREE, (PbF), SOLDERING**

If lead free solder was used in the manufacture of this product the printed circuit boards will be marked PbF.

Standard leaded, (Pb), solder can be used as usual on boards without the PbF mark.

When this mark does appear please read and follow the special instructions described in this manual on the use of PbF and how it might be permissible to use Pb solder during service and repair work.

# Panasonic

© 2003 Panasonic Communications Co., Ltd. All rights reserved. Unauthorized copying and distribution is a violation of law.

# CONTENTS

	Page		Page
<b>1 INTRODUCTION</b> .....	<b>3</b>	7.10. ITS (Integrated Telephone System) AND MONITOR SECTION .....	151
1.1. ABOUT LEAD FREE SOLDER (PbF: Pb free) .....	3	7.11. TAM INTERFACE SECTION .....	152
1.2. SAFETY PRECAUTIONS .....	5	7.12. OPERATION BOARD SECTION .....	154
1.3. INSULATION RESISTANCE TEST .....	5	7.13. LCD SECTION .....	155
1.4. FOR SERVICE TECHNICIANS .....	5	7.14. POWER SUPPLY BOARD SECTION .....	156
1.5. BATTERY CAUTION .....	5	<b>8 REFERENCE MATERIAL DATA</b> .....	<b>159</b>
1.6. AC CAUTION .....	6	8.1. TERMINAL GUIDE OF THE ICs TRANSISTORS AND DIODES .....	159
1.7. PERSONAL SAFETY PRECAUTIONS .....	6	8.2. HOW TO REPLACE THE FLAT PACKAGE IC .....	160
1.8. SERVICE PRECAUTIONS .....	7	8.3. TEST CHART .....	162
<b>2 FEATURES AND SPECIFICATIONS</b> .....	<b>8</b>	<b>9 FIXTURES AND TOOLS</b> .....	<b>164</b>
2.1. FEATURES .....	8	<b>10 CABINET, MECHANICAL AND ELECTRICAL PARTS LOCATION</b> .....	<b>165</b>
2.2. OPTIONAL ACCESSORIES .....	8	10.1. GENERAL SECTION .....	165
2.3. SPECIFICATIONS .....	9	10.2. OPERATION PANEL SECTION .....	166
<b>3 INSTALLATION</b> .....	<b>10</b>	10.3. BACK COVER SECTION .....	167
3.1. LOCATION OF CONTROLS .....	10	10.4. UPPER CABINET SECTION .....	169
3.2. CONNECTIONS .....	12	10.5. LOWER CABINET / P.C.BOARD SECTION .....	170
3.3. INSTALLATION .....	13	10.6. MOTOR SECTION .....	171
<b>4 MAINTENANCE</b> .....	<b>20</b>	10.7. ACTUAL SIZE OF SCREWS .....	171
4.1. MAINTENANCE ITEMS AND COMPONENT LOCATIONS .....	20	<b>11 ACCESSORIES AND PACKING MATERIALS</b> .....	<b>172</b>
4.2. GEAR SECTION .....	23	<b>12 REPLACEMENT PARTS LIST</b> .....	<b>173</b>
4.3. JAMS .....	25	12.1. CABINET AND ELECTRICAL PARTS .....	173
4.4. CLEANING .....	27	12.2. DIGITAL BOARD PARTS .....	174
<b>5 DISASSEMBLY INSTRUCTIONS</b> .....	<b>30</b>	12.3. ANALOG BOARD PARTS .....	177
5.1. DISASSEMBLY FLOW CHART .....	30	12.4. OPERATION BOARD PARTS .....	178
5.2. DISASSEMBLY PROCEDURE .....	32	12.5. POWER SUPPLY BOARD PARTS .....	178
5.3. INSTALLATION POSITION OF THE LEAD WIRES .....	44	12.6. SENSOR BOARD PARTS .....	179
<b>6 TROUBLESHOOTING GUIDE</b> .....	<b>45</b>	12.7. FIXTURES AND TOOLS .....	179
6.1. USER RECOVERABLE ERRORS .....	45	<b>13 PRINTED CIRCUIT BOARD</b> .....	<b>180</b>
6.2. PROGRAMMING AND LISTS .....	47	13.1. DIGITAL BOARD (PCB1) .....	180
6.3. TEST FUNCTIONS .....	50	13.2. ANALOG BOARD (PCB2) .....	182
6.4. REMOTE PROGRAMMING .....	53	13.3. OPERATION BOARD (PCB3) .....	184
6.5. THE EXAMPLE OF THE PRINTED LIST .....	56	13.4. SENSOR BOARD (PCB5) .....	185
6.6. TROUBLESHOOTING DETAILS .....	60	13.5. POWER SUPPLY BOARD (PCB4) .....	186
<b>7 CIRCUIT OPERATIONS</b> .....	<b>116</b>	<b>14 FOR THE SCHEMATIC DIAGRAMS</b> .....	<b>187</b>
7.1. CONNECTION DIAGRAM .....	116	<b>15 SCHEMATIC DIAGRAM</b> .....	<b>188</b>
7.2. GENERAL BLOCK DIAGRAM .....	117	15.1. ANALOG BOARD (PCB2) .....	188
7.3. CONTROL SECTION .....	119	15.2. DIGITAL BOARD (PCB1) .....	190
7.4. FACSIMILE SECTION .....	127	15.3. OPERATION BOARD (PCB3) .....	194
7.5. GEAR SECTION .....	135	15.4. POWER SUPPLY BOARD (PCB4) .....	195
7.6. SENSORS AND SWITCHES .....	135	15.5. SENSOR BOARD (PCB5) .....	196
7.7. MODEM SECTION .....	138		
7.8. ANALOG SECTION .....	145		
7.9. NCU SECTION .....	147		

# 1 INTRODUCTION

## 1.1. ABOUT LEAD FREE SOLDER (PbF: Pb free)

### Note:

In the information below, Pb, the symbol for lead in the periodic table of elements, will refer to standard solder or solder that contains lead.

We will use PbF solder when discussing the lead free solder used in our manufacturing process which is made from Tin (Sn), Silver, (Ag), and Copper, (Cu).

This model, and others like it, manufactured using lead free solder will have PbF stamped on the PCB. For service and repair work we suggest using the same type of solder although, with some precautions, standard Pb solder can also be used.

### Caution

- PbF solder has a melting point that is 50° ~ 70° F, (30° ~ 40°C) higher than Pb solder. Please use a soldering iron with temperature control and adjust it to 700° ± 20° F, (370° ± 10°C). In case of using high temperature soldering iron, please be careful not to heat too long.
- PbF solder will tend to splash if it is heated much higher than its melting point, approximately 1100°F, (600°C).
- If you must use Pb solder on a PCB manufactured using PbF solder, remove as much of the original PbF solder as possible and be sure that any remaining is melted prior to applying the Pb solder.
- When applying PbF solder to double layered boards, please check the component side for excess which may flow onto the opposite side (See figure, below).

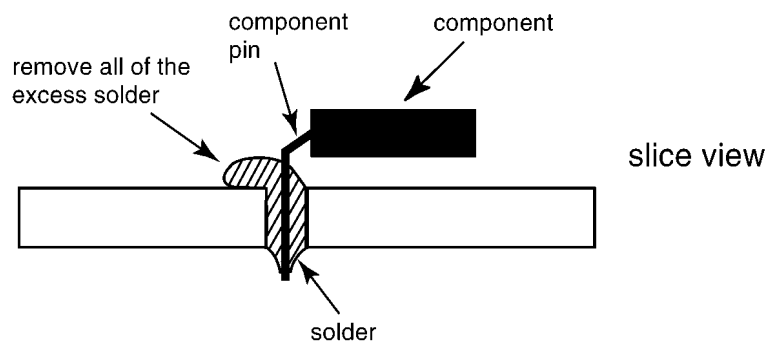

### 1.1.1. SUGGESTED PbF SOLDER

There are several types of PbF solder available commercially. While this product is manufactured using Tin, Silver, and Copper, (Sn+Ag+Cu), you can also use Tin and Copper, (Sn+Cu), or Tin, Zinc, and Bismuth, (Sn+Zn+Bi). Please check the manufacturer's specific instructions for the melting points of their products and any precautions for using their product with other materials.

The following lead free (PbF) solder wire sizes are recommended for service of this product: 0.3mm, 0.6mm and 1.0mm.

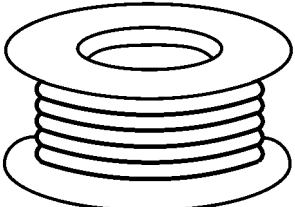
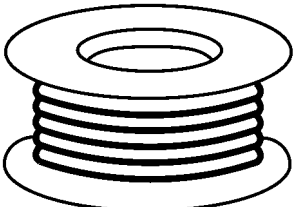
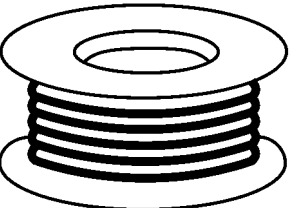
0.3mm X 100g	0.6mm X 100g	1.0mm X 100g
		

### 1.1.2. HOW TO RECOGNIZE THAT Pb FREE SOLDER IS USED

P.C.Boards marked as "PbF" use Pb Free solder. (See the figure below.)  
Pb Free is not used the Power Supply Board of this unit.

(Example : Digital Board)

(Digital Board : Component View)

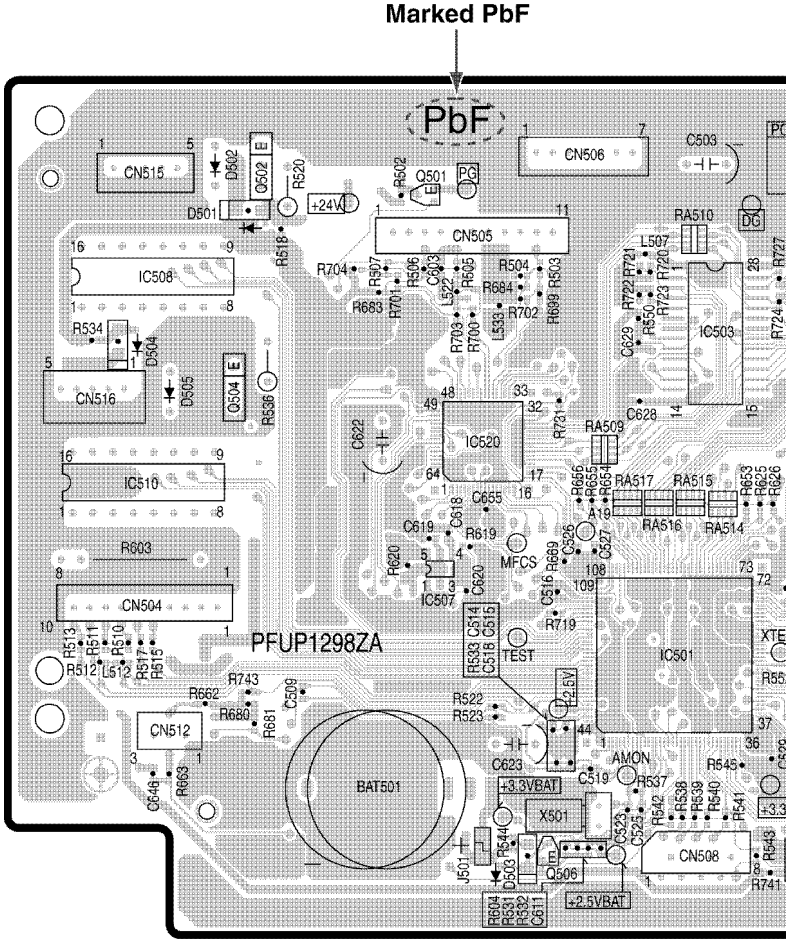

**Note:**

The "PbF" marked may be found on different areas of the same P.C.Board, depending on manufacture date.

## 1.2. SAFETY PRECAUTIONS

1. Before servicing, unplug the AC power cord to prevent an electric shock.
2. When replacing parts, use only the manufacturer's recommended components.
3. Check the condition of the power cord. Replace if wear or damage is evident.
4. After servicing, be sure to restore the lead dress, insulation barriers, insulation papers, shields, etc.
5. Before returning the serviced equipment to the customer, be sure to perform the following insulation resistance test to prevent the customer from being exposed to shock hazards.

## 1.3. INSULATION RESISTANCE TEST

1. Unplug the power cord and short the two prongs of the plug with a jumper wire.
2. Turn on the power switch.
3. Measure the resistance value with an ohmmeter between the jumpered AC plug and each exposed metal cabinet part (screw heads, control shafts, bottom frame, etc.).

Note: Some exposed parts may be isolated from the chassis by design. These will read infinity.

4. If the measurement is outside the specified limits, there is a possibility of a shock hazard.

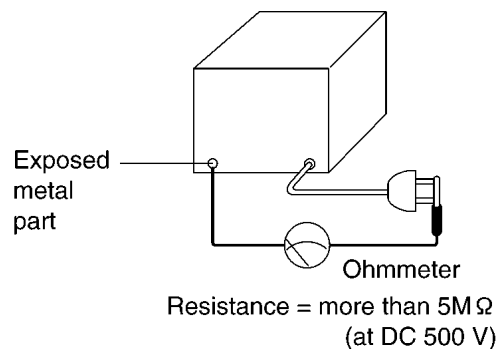

## 1.4. FOR SERVICE TECHNICIANS

ICs and LSIs are vulnerable to static electricity.

When repairing, the following precautions will help prevent recurring malfunctions.

1. Cover the plastic part's boxes with aluminum foil.
2. Ground the soldering irons.
3. Use a conductive mat on the worktable.
4. Do not touch the IC or LSI pins with bare fingers.

## 1.5. BATTERY CAUTION

### CAUTION

Danger of explosion if the battery is incorrectly replaced. Replace only with the same or equivalent type recommended by the manufacturer. Dispose of used batteries according to the manufacturer's Instructions.

The lithium battery is a critical component (type No. CR2032). Please observe for the proper polarity and the exact location when replacing it and the exact location when replacing it and soldering the replacement lithium battery in.

Recommend Type Number:

CR2032 (BAT501) Manufactured by MATSUSHITA/SONY/TOSHIBA/HITACHI

## 1.6. AC CAUTION

For safety, before closing the lower cabinet, please make sure of the following precautions.

1. The earth lead is fixed with the screw.
2. The AC connector is connected properly.
3. Wrap the earth lead around the core 3 times.
4. Wrap the AC lead around the core 3 times.

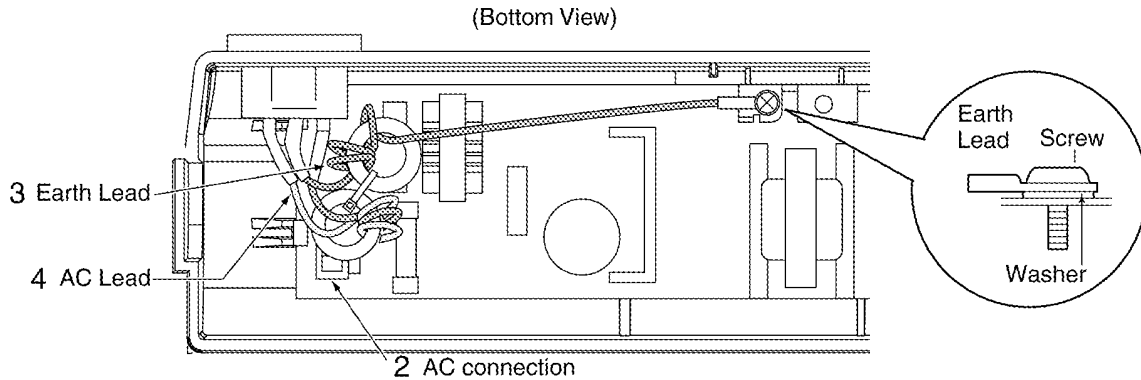

## 1.7. PERSONAL SAFETY PRECAUTIONS

### 1.7.1. MOVING SECTIONS OF THE UNIT

Be careful not to let your hair, clothes, fingers, accessories, etc., become caught in any moving sections of the unit.

The moving sections of the unit are the rollers and a gear. There is a separation roller and a document feed roller which are rotated by the document feed motor. A gear rotates the two rollers. Be careful not to touch them with your hands, especially when the unit is operating.

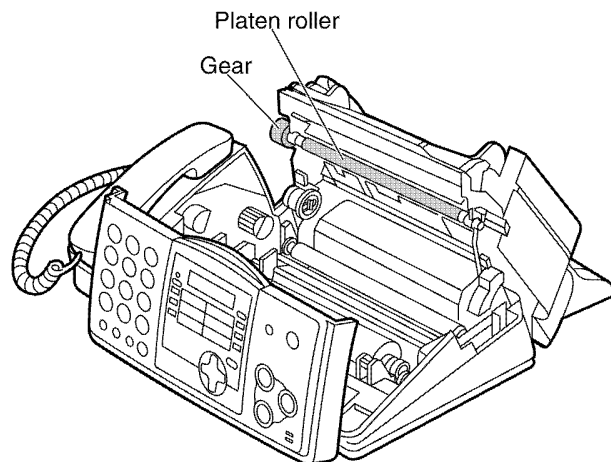
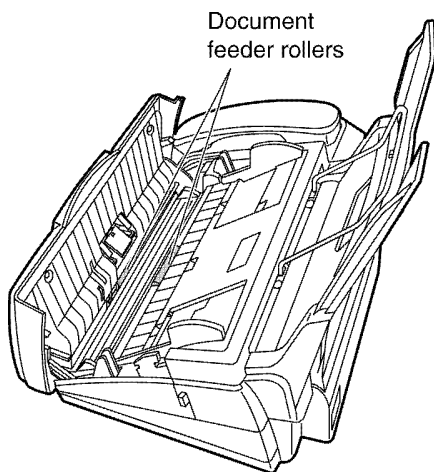

## 1.7.2. LIVE ELECTRICAL SECTIONS

All the electrical sections of the unit supplied with AC power by the AC power cord are live.  
Never disassemble the unit for service with the AC power supply plugged in.

### CAUTION:

AC voltage is supplied to the primary side of the power supply unit. Therefore, always unplug the AC power cord before disassembling for service.

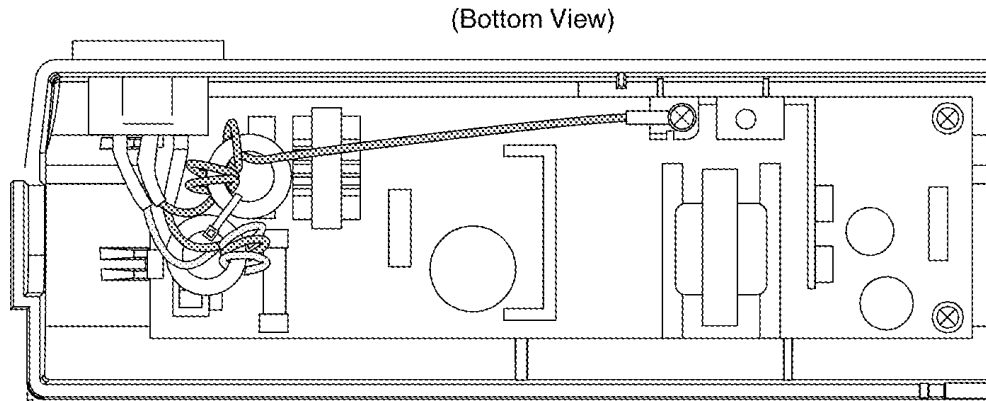

## 1.8. SERVICE PRECAUTIONS

### 1.8.1. PRECAUTIONS TO PREVENT DAMAGE FROM STATIC ELECTRICITY

Electrical charges accumulate on a person. For instance, clothes rubbing together can damage electric elements or change their electrical characteristics. In order to prevent static electricity, touch a metallic part that is grounded to release the static electricity. Never touch the electrical sections such as the power supply unit, etc.

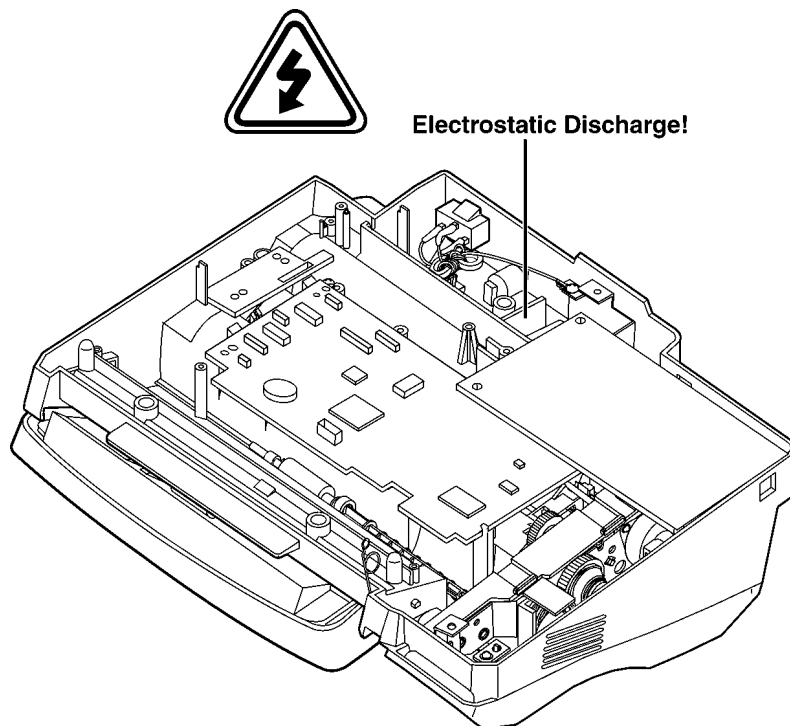

## 2 FEATURES AND SPECIFICATIONS

### 2.1. FEATURES

#### General

- Help function
- Display:
  - QUICK SET UP
  - FEATURE LIST
  - DIRECTORY
  - FAX RECEIVING
  - COPIER
  - ERRORS
  - CALLER ID
- LCD (Liquid Crystal Display) readout
- TAM (Telephone answering machine) interface

#### Plain Paper Facsimile Machine

- 12 second transmission speed \*
- A4 / Letter, G3 compatible
- Automatic document feeder (10 sheets)
- Quick scan
- Resolution: Standard / Fine / Super fine / Photo (64 level)
- Broad cast with Navigator
- 50-sheet paper capacity
- Distinctive ring detection \*\*

\* The 12 second speed is based upon the ITU-T No. 1 Test Chart on the condition that memory transmission is performed.

\*\* Subscription to distinctive ring services is required.

#### Large Memory (28 pages)... Performed by DRAM

- Approx. 25 pages of memory transmission
- Approx. 28 pages of memory reception

#### Integrated Telephone System

- On-hook dialing
- Monitor speaker
- Voice muting
- Redialing function
- 100-Station telephone directory with Navigator/one-touch key
- Caller ID compatible\*\*\*

\*\*\*Feature requires a subscription to caller identification services offered by certain local telephone companies for a fee. You and your caller(s) must be in areas that provide caller identification services, and compatible equipment must be used by both telephone companies. Feature not available when the unit is connected to a PBX system.

#### Enhanced Copier Function

- Multi-copy function (up to 50 copies)
- Enlargement and reduction
- Collate
- 64-Level halftone

### 2.2. OPTIONAL ACCESSORIES

- The included film roll is 10 meters long. We recommend that you buy a full-size replacement film 70 meters for continuous use of your unit. For best results, use genuine Panasonic replacement film as follows:

Model No.	Description	Specifications
KX-FA57E/KX-FA57A	Replacement Film	216 mm x 70 m

#### Note:

The ink film is not reusable. Do not rewind and use the ink film again.



## 2.3. SPECIFICATIONS

<b>Applicable Lines:</b>	Public Switched Telephone Network
<b>Document Size:</b>	Max. 216 mm in width Max. 600 mm in length
<b>Effective Scanning Width:</b>	208 mm
<b>Recording Paper Size:</b>	A4: 210×297 mm Letter: 216×279 mm
<b>Effective Printing Width:</b>	208 mm
<b>Transmission Time*<sup>1</sup>:</b>	Approx. 12 s/page (Original mode)* <sup>2</sup>
<b>Scanning Density:</b>	Horizontal: 8 pels/mm Vertical: 3.85 lines/mm—STANDARD mode 7.7 lines/mm—FINE / PHOTO mode 15.4 lines/mm—SUPER FINE Mode
<b>Halftone Level:</b>	64-level
<b>Scanner Type:</b>	Contact Image Sensor (CIS)
<b>Printer Type:</b>	Thermal Transfer on Plain Paper
<b>Data Compression System:</b>	Modified Huffman (MH), Modified READ (MR)
<b>Modem Speed:</b>	9,600/7,200/4,800/2,400 bps; Automatic Fallback
<b>Operating Environment:</b>	5—35°C, 20—80 % RH (Relative Humidity)
<b>Dimensions:</b>	Approx. height 185 mm × width 355 mm × depth 275 mm
<b>Mass (Weight):</b>	Approx. 3.4 kg
<b>Power Consumption:</b>	Standby: Approx. 4.0 W Transmission: Approx. 12 W Reception: Approx. 40 W (When receiving a 20% black document) Copy: Approx. 55 W (When copying a 20% black document) Maximum: Approx. 135 W (When copying a 100% black document)
<b>Power Supply:</b>	220-240 V AC, 50/60 Hz
<b>Memory Capacity:</b>	Approx. 25 pages memory transmission Approx. 28 pages memory reception (Based on ITU-T No. 1 Test Chart in standard resolution.)

\*<sup>1</sup> Transmission speed depends upon the contents of the pages, resolution, telephone line conditions and capability of the other party's machine.

\*<sup>2</sup> Transmission speed is based upon the ITU-T No. 1 Test Chart and original mode. (Refer to **ITU-T No.1 TEST CHART (P.162).**)  
If the capability of the other party's machine is inferior to your unit, the transmission time may be longer.

**Note:**

- Any details given in these instructions are subject to change without notice.
- The pictures and illustrations in these instructions may vary slightly from the actual product.

### 3 INSTALLATION

#### 3.1. LOCATION OF CONTROLS

##### 3.1.1. FRONT VIEW

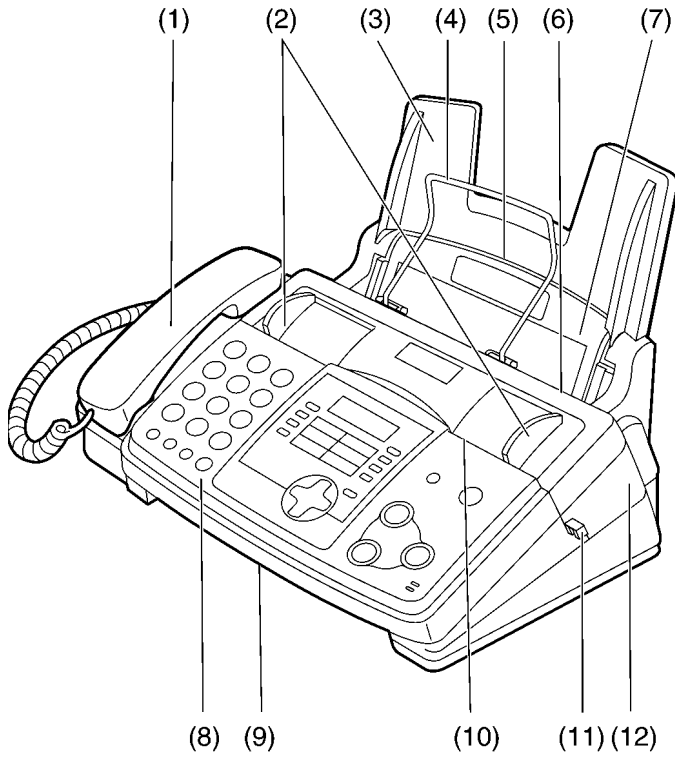

- (1) Handset
- (2) Document guides
- (3) Paper tray
- (4) Recording paper support
- (5) Recording paper entrance
- (6) Recording paper exit
- (7) Tension plate
- (8) Front cover
- (9) Document exit
- (10) Document entrance
- (11) Back cover open button
- (12) Back cover

##### 3.1.2. REAR VIEW

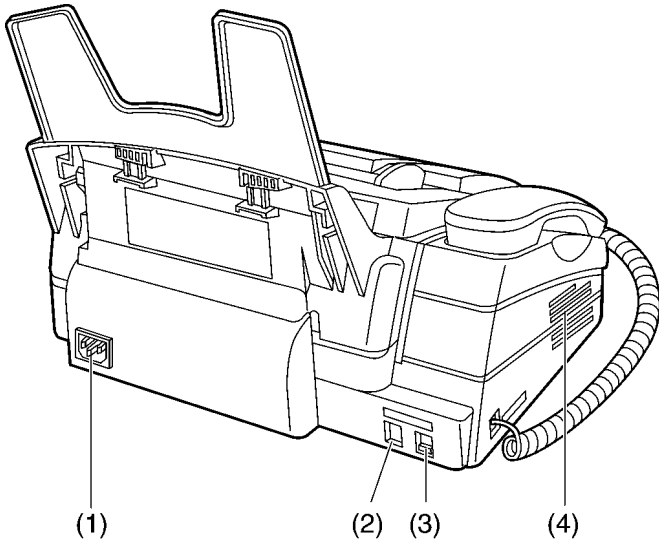

- (1) Power inlet
- (2) Telephone line jack
- (3) External telephone jack
- (4) Speaker

### 3.1.3. CONTROL PANEL

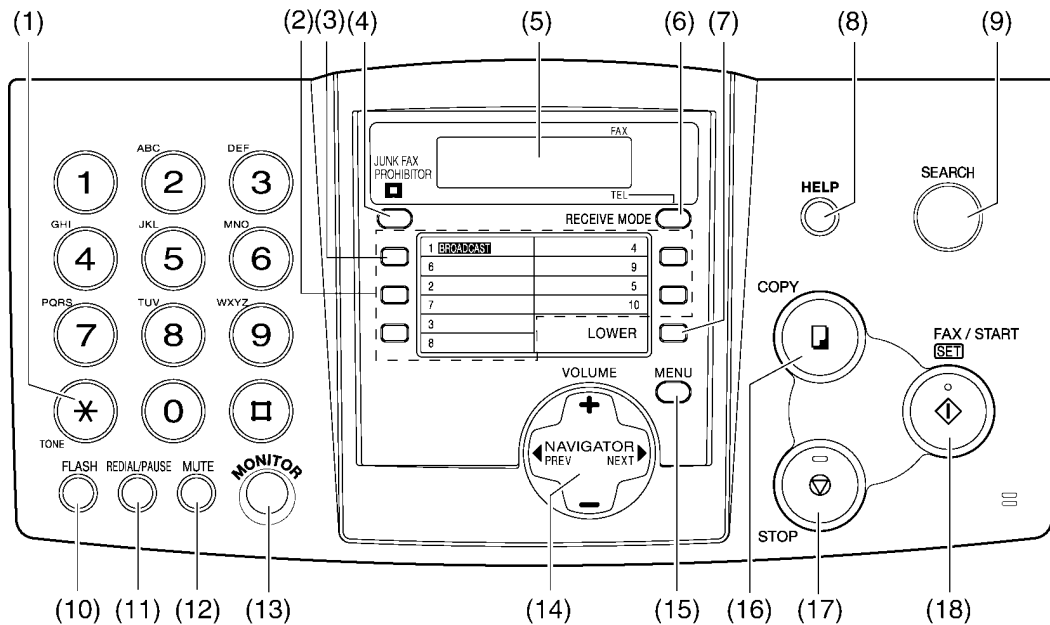

#### (1) [TONE]

- To change from pulse to tone temporarily during dialing when your line has rotary pulse services.

#### (2) One-touch keys

- To use one-touch dial.
- To transmit to multiple entries.

#### (3) BROADCAST

- To transmit a document to multiple parties.

#### (4) [JUNK FAX PROHIBITOR]

- To use junk fax prohibitor.

#### (5) Display

#### (6) [RECEIVE MODE]

- To change the receiving mode.

#### (7) [LOWER]

- To select stations 6-10 for one-touch dial.

#### (8) [HELP]

- To print a quick reference.

#### (9) [SEARCH]

- To use caller ID service.

#### (10) [FLASH]

- To access special telephone services such as call waiting or for transferring extension calls.

#### (11) [REDIAL/PAUSE]

- To redial the last number dialed. If the line is busy when you make a phone call using the [MONITOR] button, the unit will automatically redial the number up to 5 times.
- To insert a pause during dialing.

#### (12) [MUTE]

- To mute your voice to the other party during a conversation. Press this button again to resume the conversation.

#### (13) [MONITOR]

- To initiate dialing without lifting the handset.

#### (14) [NAVIGATOR, VOLUME]

- To adjust volume.
- To search for a stored name.
- To select the features or feature settings during programming.
- To navigate to the next operation.

#### (15) [MENU]

- To initiate or exit programming.

#### (16) [COPY]

- To initiate copying.

#### (17) [STOP]

- To stop an operation or cancel programming.

#### (18) [FAX/START, SET]

- To initiate fax transmission or reception.
- To store a setting during programming.

## 3.2. CONNECTIONS

- (1) Connect the handset cord.
- (2) Connect the telephone line cord.
- (3) Connect the power cord.

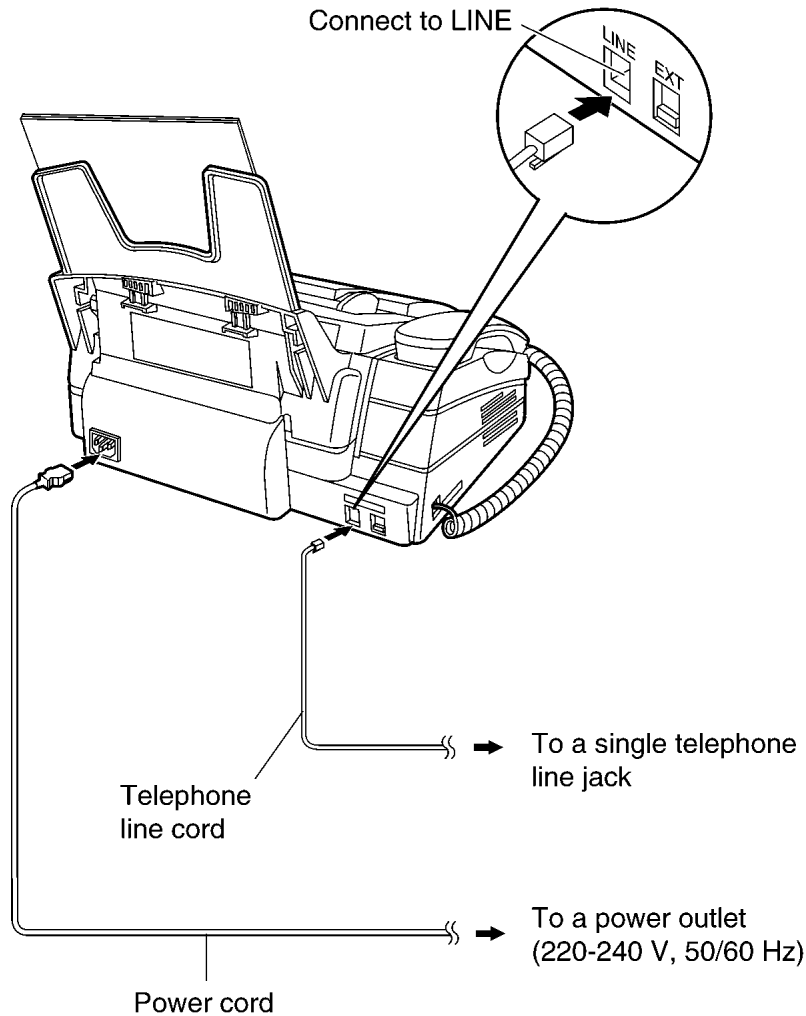

### Warning:

- If any other device is connected on the same line, this unit may disturb the network condition of the device.

### Caution:

- When you operate this product, the power outlet should be near the product and easily accessible.

### Using surge protectors:

- The warranty does not cover damage due to power line surges or lightning. For additional equipment protection, we recommend the use of a surge protector. The following types are available: TELESPIKE BLOK MODEL TSB (TRIPPE MFG. CO.), SPIKE BLOK MODEL SK6-0 (TRIPPE MFG. CO.), SUPER MAX (PANAMAX) or MP1 (ITW LINX).

### 3.3. INSTALLATION

#### 3.3.1. INSTALLATION SPACE

The space required to install the unit is shown below.

The dimensions given are necessary for the unit to operate efficiently.

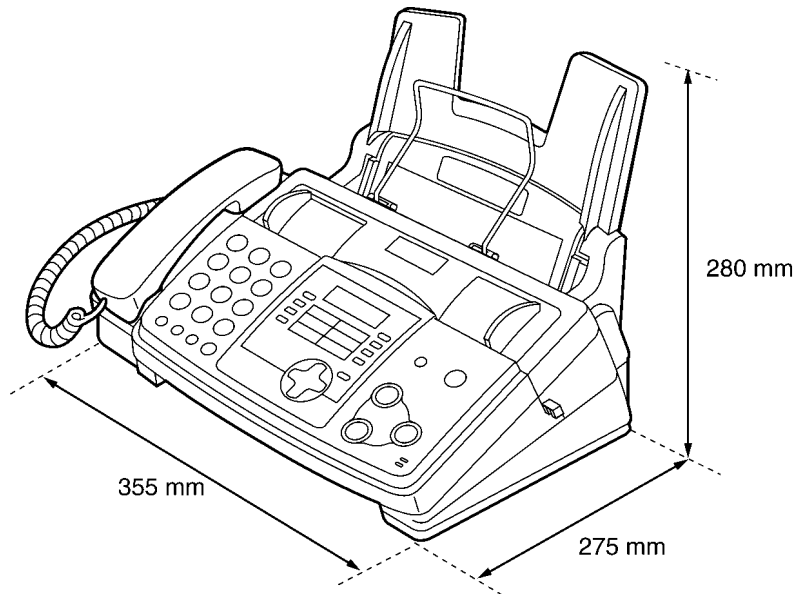

**Note:**

- Avoid excessive heat or humidity.
- Use the unit within the following ranges of temperature and humidity.
- Ambient temperature: 5°C to 35°C
- Relative humidity: 20% to 80% (without condensation)
- Power cord length should be less than 5 meters. Using a longer cord may reduce the voltage or cause malfunctions.
- Avoid direct sunlight.
- Do not install near devices which contain magnets or generate magnetic fields.
- Do not subject the unit to strong physical shock or vibration.
- Keep the unit clean. Dust accumulation can prevent the unit from functioning properly.
- To protect the unit from damage, hold both sides when you move it.

### 3.3.2. INSTALLING THE PAPER TRAY

The included paper tray is for letter size recording paper. Insert tabs on the paper tray into slits on the back of the unit.

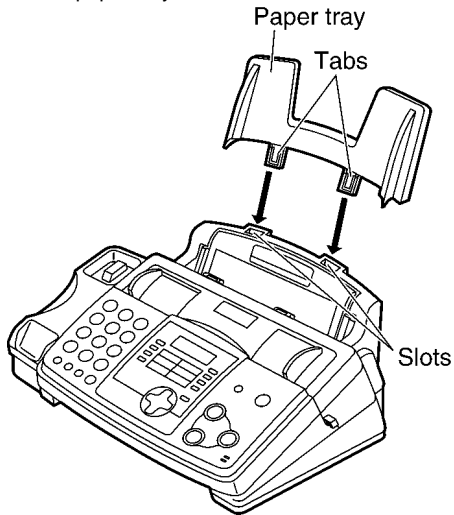

**Note:**  
 · Do not place the unit in areas where the paper tray may be obstructed (i.e. by a wall, etc.).

#### To use A4 size paper

You need to install the A4 paper guide to the right side of the paper tray.

1. Insert the bottom tab on the A4 paper guide into the lower slot.
2. Press the guide into the upper slot.

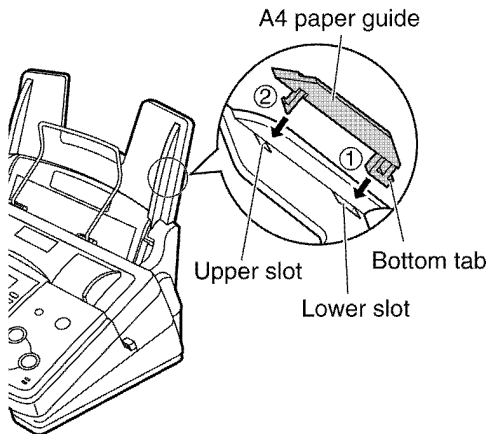

### 3.3.3. INSTALLING THE RECORDING PAPER SUPPORT

Attach the recording paper support into the slots on the recording paper exit.

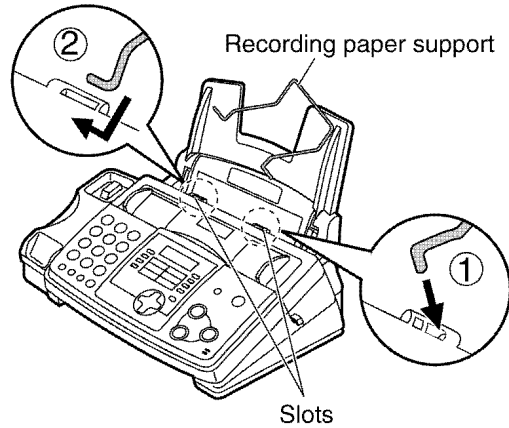

The recording paper will be ejected from the top of the unit after printing. The recording paper support prevents the printed paper from curling.

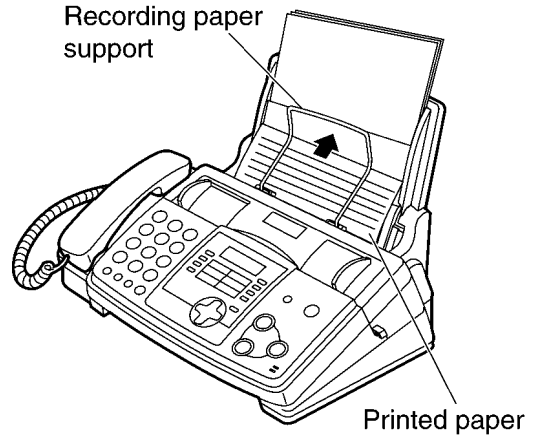

### 3.3.4. HANDSET

Connect the handset cord.

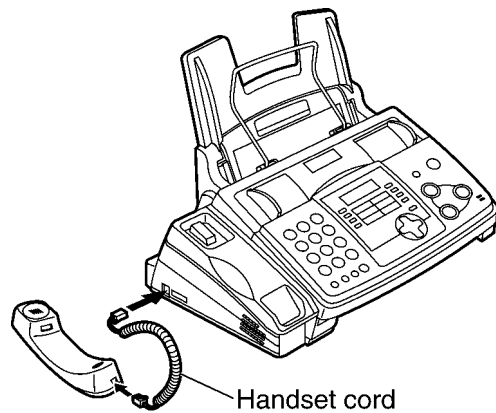

### 3.3.5. INSTALLING THE INK FILM

- 1 Open the front cover by pulling up the center part.

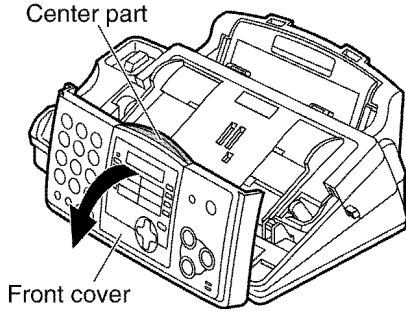

- 2 Push the back cover open button (green) on the right side of the unit.  
OR  
Push the back cover open lever (green) inside of the unit.

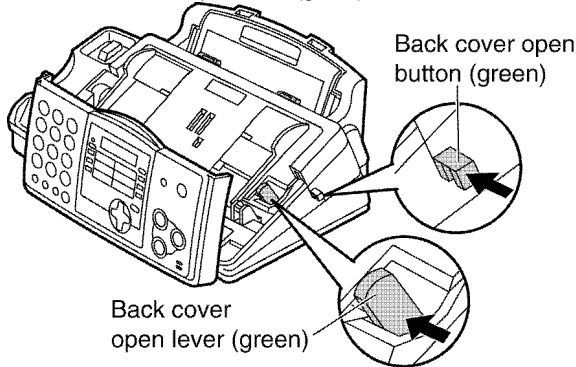

- 3 Open the back cover.

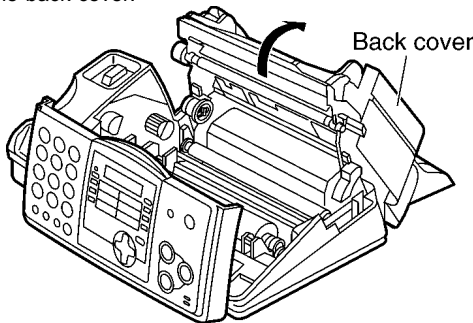

- 4 Insert the gear of blue core of the front ink film roll into the left slot of the unit (①). Insert the rear ink film roll (②).

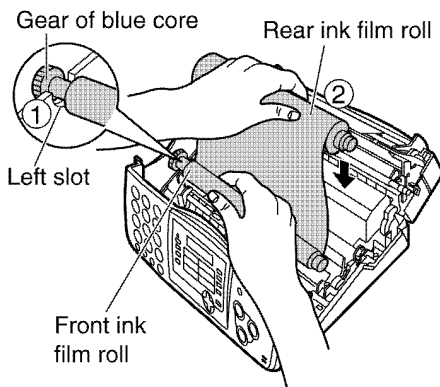

- 5 Turn the gear of blue core in the direction of the arrow.

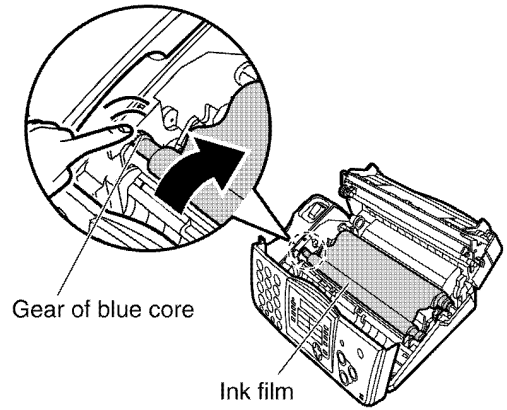

• Make sure that the ink film is wrapped around the blue core at least once.

**Correct**

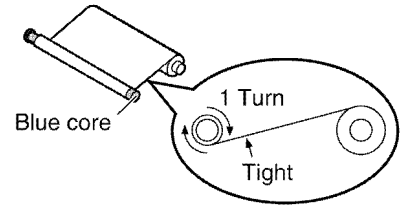

**Incorrect**

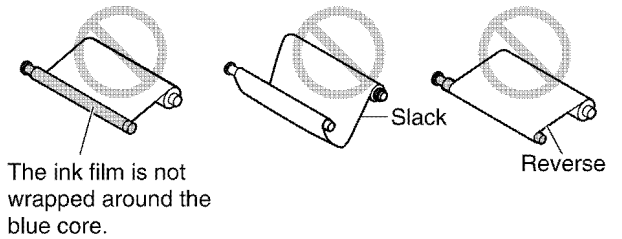

- 6 Close the back cover securely by pushing down on the dotted area at both ends (①). Close the front cover securely (②).

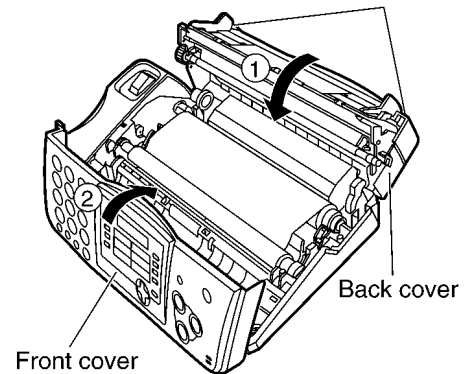

• The ink film is safe to touch and will not rub off on your hands like carbon paper.

### 3.3.6. INSTALLING THE RECORDING PAPER

Letter or A4 size recording paper can be loaded. The unit can hold up to 50 sheets of 75 g/m<sup>2</sup> paper. You may use 60 g/m<sup>2</sup> to 90 g/m<sup>2</sup> paper. See the note for paper specifications.

- 1 Fan the stack of paper to prevent a paper jam.

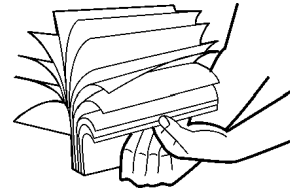

- 2 Pull the tension plate forward and hold open while inserting the paper.

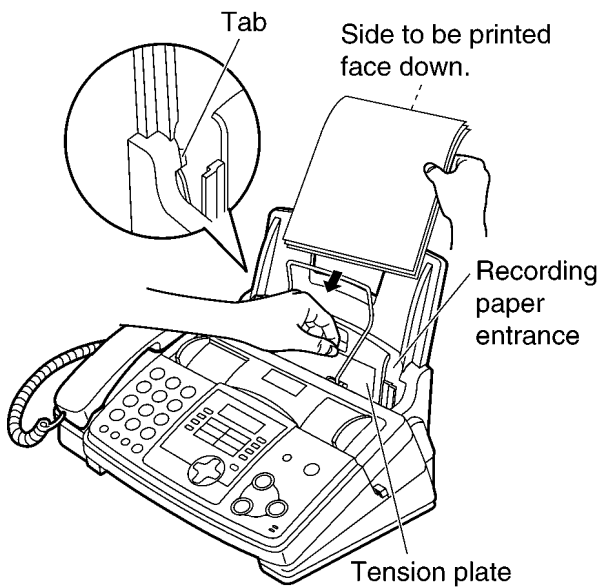

- The paper should not be over the tab.
- If the paper is not inserted correctly, readjust the paper, or the paper may jam.

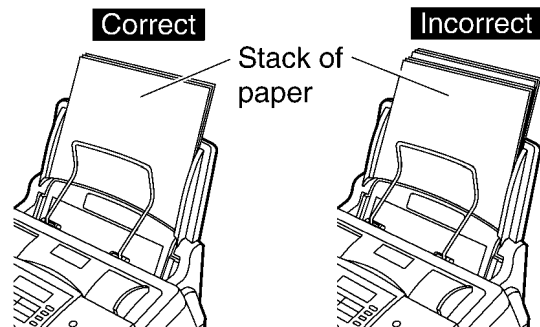

#### To add paper

1. Pull the tension plate forward and hold open while removing all of the installed paper.
2. Add paper to the stack of paper you removed and straighten.
3. Fan the stack of paper.
4. Pull the tension plate forward and hold open while inserting the paper.

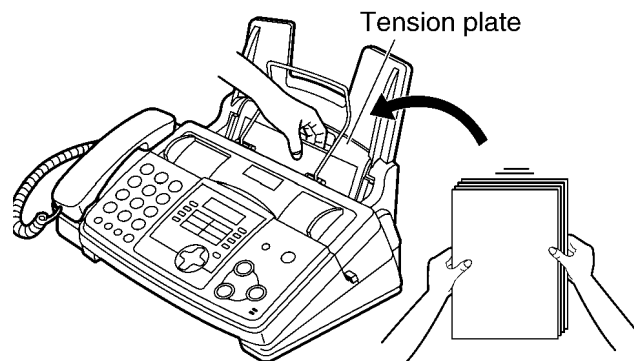



### 3.3.7. DOCUMENTS THE UNIT CAN FEED

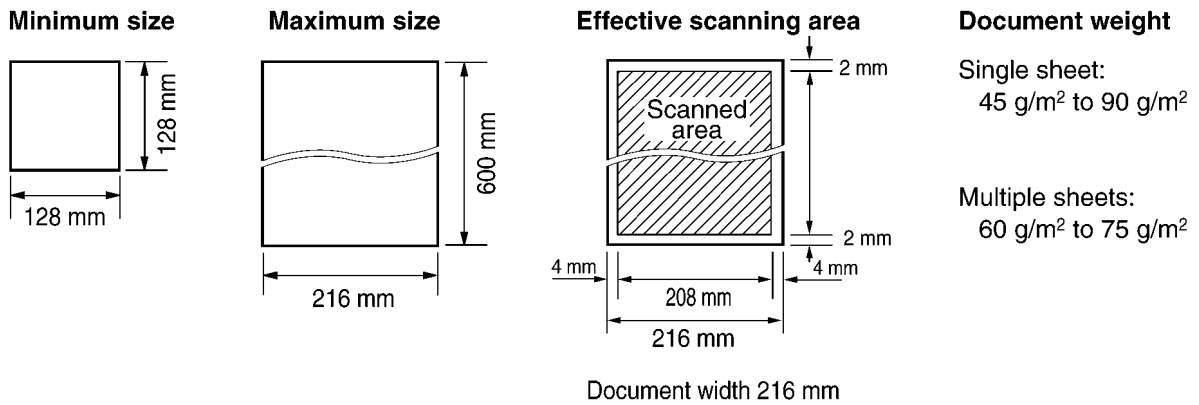

**Note:**

- Remove chips, staples or other similar fasteners.
- Do not send the following types of documents. (Use the scanner glass for fax transmission.)
  - Chemically treated paper such as carbon or carbon less duplicating paper
  - Electrostatically charged paper
  - Badly curled, creased or torn paper
  - Paper with a coated surface
  - Paper with a faint image
  - Paper with printing on the opposite side that can be seen through the other side (i.e. newspaper)
- Check that ink, paste or correction fluid has dried completely.
- To transmit the document with a width of less than standard letter size (216 mm), we recommend using a copy machine to copy the original document onto letter-sized paper, than transmit the copied document.

### 3.3.8. SETTING YOUR LOGO

The logo can be your company, division or name.

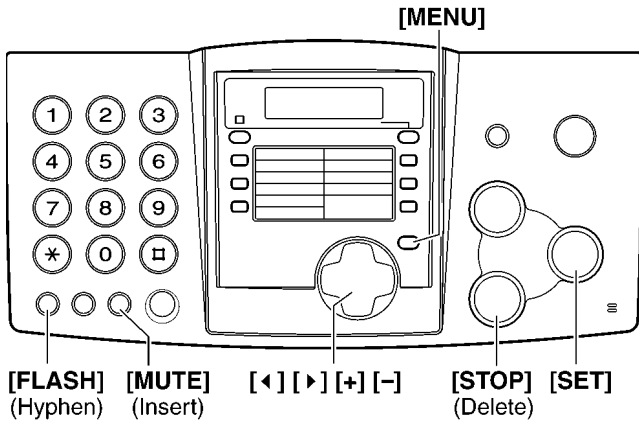

1 Press [MENU].

SYSTEM SET UP  
PRESS NAVI. [◀ ▶]

2 Press [◀] or [▶] until the following is displayed.

YOUR LOGO  
PRESS SET

3 Press [SET].

LOGO=

4 Enter your logo, up to 30 characters, using the dial keypad.

**Example: "BILL"**

1. Press [2] 2 times.

· Cursor ( ) will appear on the display.

LOGO=B

2. Press [4] 3 times.

LOGO=BI

3. Press [5] 3 times.

LOGO=BIL

4. Press [▶] to move the cursor to the next space and press [5] 3 times.

LOGO=BILL

5 Press [SET].

· The next feature will be displayed.

6 Press [MENU].

**Note:**

· You can enter your logo by pressing [+ ] or [- ] in step 4. In this case, press [▶] to move the cursor.

#### To change capital or lower-case letters

Pressing the [#] key will change to capital or lower-case alternatively.

1. Press [2] 2 times.

LOGO=B

2. Press [4] 3 times.

LOGO=BI

3. Press [#].

LOGO=Bi

4. Press [5] 3 times.

LOGO=BiL

#### To correct a mistake

Press [◀] or [▶] to move the cursor to the incorrect character, and make the correction.

#### To delete a character

Press [◀] or [▶] to move the cursor to the character you want to delete and press [STOP].

#### To insert a character

1. Press [◀] or [▶] to move the cursor to the position to the right of where you want to insert the character.

2. Press [MUTE] to insert a space and enter the character.

### 3.3.8.1. TO SELECT CHARACTERS WITH THE DIAL KEYPAD

Pressing the dial keys will select a character as shown below.

Keys	Characters
[1]	1 [ ] { } + - / = , . _ ` : ; ?
[2]	A B C a b c 2
[3]	D E F d e f 3
[4]	G H I g h i 4
[5]	J K L j k l 5
[6]	M N O m n o 6
[7]	P Q R S p q r s 7
[8]	T U V t u v 8
[9]	W X Y Z w x y z 9
[0]	0 ( ) < > ! " # \$ % & ¥ * @ ^ ' →
[□]	To change capital or lower case letter.
[FLASH]	Hyphen button (To insert a hyphen.)
[MUTE]	Insert button (To insert one character or one space.)
[STOP]	Delete button (To delete a character.)
[▶]	▶ key (To move the cursor to the right.) To enter another character using the same number key, move the cursor to the next space.
[◀]	◀ key (To move the cursor to the left.)

#### To select characters using [+] or [-]

Instead of pressing the dial keys, you can select characters using [+] or [-].

1. Press [+] or [-] until the desired character is displayed.
2. Press [▶] to move the cursor to the next space.
  - The character displayed in step 1 is inserted.
3. Return to step 1 to enter the next character.

#### Display order of characters

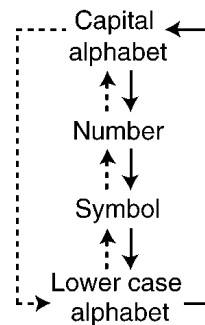

→ : Pressing **[+]**

-> : Pressing **[-]**

## 4 MAINTENANCE

### 4.1. MAINTENANCE ITEMS AND COMPONENT LOCATIONS

#### 4.1.1. OUTLINE

MAINTENANCE AND REPAIRS ARE PERFORMED USING THE FOLLOWING STEPS.

**1. Periodic maintenance**

Inspect the equipment periodically and if necessary, clean any contaminated parts.

**2. Check for breakdowns**

Look for problems and consider how they arose.

If the equipment can be still used, perform copying, self testing or communication testing.

**3. Check equipment**

Perform copying, self testing and communication testing to determine if the problem originates from the transmitter, receiver or the telephone line.

**4. Determine causes**

Determine the causes of the equipment problem by troubleshooting.

**5. Equipment repairs**

Repair or replace the defective parts and take appropriate measures at this stage to ensure that the problem will not recur.

**6. Confirm normal operation of the equipment**

After completing the repairs, conduct copying, self testing and communication testing to confirm that the equipment operates normally.

**7. Record keeping**

Make a record of the measures taken to rectify the problem for future reference.

### 4.1.2. COMPONENT LOCATIONS

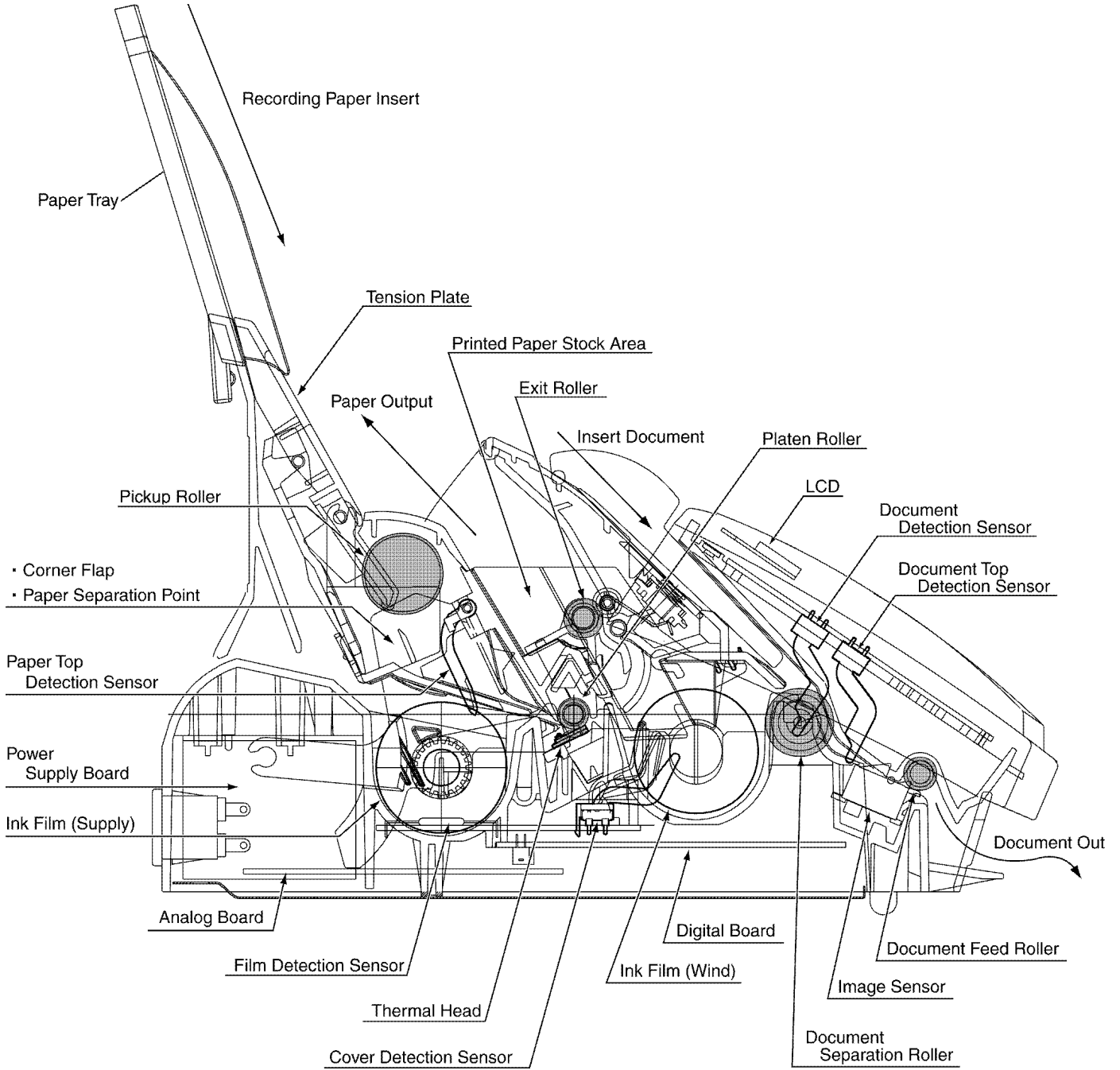

### 4.1.2.1. MAINTENANCE LIST

NO.	OPERATION	CHECK	REMARKS
1	Document Path	Remove any foreign matter such as paper.	—
2	Rollers	If the roller is dirty, clean it with a damp cloth then dry thoroughly.	Refer to <b>DOCUMENT FEEDER</b> (P.27).
3	Platen Roller	If the platen is dirty, clean it with a damp cloth then dry thoroughly. Remove the paper and film cartridge before cleaning.	—
4	Thermal Head	If the thermal head is dirty, clean the printing surface with a cloth moistened with denatured alcohol (alcohol without water), then dry thoroughly.	Refer to <b>THERMAL HEAD</b> (P.28).
5	Sensors	Hook switch (SW101), Paper top sensor (PS501), Film end (SW501), Cover open switch (SW502), Document top switch (SW353), Document set switch (SW352). Confirm the operation of the sensors.	See <b>COMPONENT LOCATIONS</b> (P.21) and <b>HOW TO REMOVE THE DIGITAL, ANALOG, POWER SUPPLY, SENSOR BOARDS AND AC INLET</b> (P.41).
6	Glass	If the glass is dirty, clean with a dry soft cloth.	Refer to <b>DOCUMENT FEEDER</b> (P.27).
7	Abnormal, wear and tear or loose parts	Replace the part. Check if the screws are tight on all parts.	—

### 4.1.2.2. MAINTENANCE CYCLE

No.	Item	Cleaning Cycle	Replacement	
			Cycle	Procedure
1	Separation Roller (Ref. No. 141)	3 months	7 years* (31,500 documents)	Refer to <b>HOW TO REMOVE THE MOTOR BLOCK AND SEPARATION ROLLER</b> (P.42).
2	Separation Rubber (Ref. No. 11)	3 months	7 years (31,500 documents)	Refer to <b>COMPONENT LOCATIONS</b> (P.21).
3	Feed Rollers (Ref. No. 9)	3 months	7 years (31,500 documents)	Refer to <b>DISASSEMBLY INSTRUCTIONS</b> (P.30).
4	Thermal Head (Ref. No. 95)	3 months	7 years (31,500 documents)	Refer to <b>HOW TO REMOVE THE THERMAL HEAD</b> (P.36).
5	Platen Roller (Ref. No. 54)	3 months	7 years (31,500 documents)	Refer to <b>HOW TO REMOVE THE PLATEN ROLLER AND BACK COVER</b> (P.37).
6	Pickup Roller (Ref. No. 46)	3 months	7 years (31,500 documents)	Refer to <b>HOW TO REMOVE THE PICKUP ROLLER</b> (P.38).

\* These values are standard and may vary depending on usage conditions.

## 4.2. GEAR SECTION

### 4.2.1. GEAR OPERATION

Once a mode is selected, the Drive Motor Gear rotates clockwise (CW) and then the controlling positions of Swing Gears A, B and C determine which gears convey their drive power in each mode. See "**Sensor Location**" in **SENSORS AND SWITCHES** (P.135).

#### 4.2.1.1. TRANSMIT MODE

The TX MOTOR rotate CCW and conveys its power to the document separation roller gear and document Exit Roller Gear.

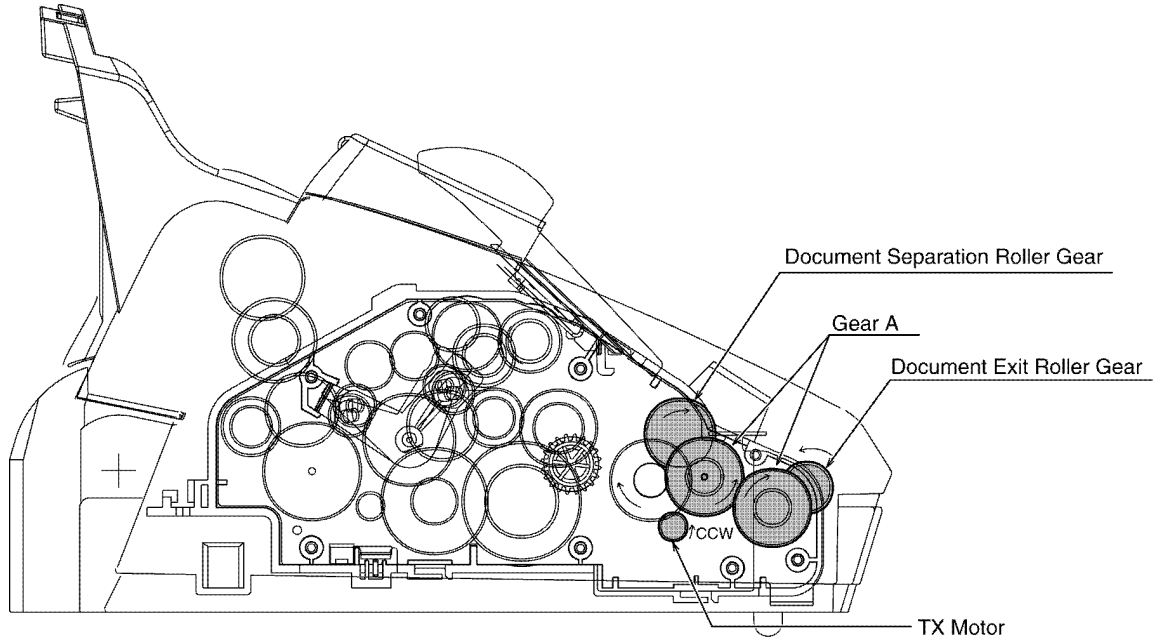

Fig. A: Transmit mode

#### 4.2.1.2. PAPER PICK UP AND PAPER EXIT MODE

The RX MOTOR rotate CCW and swing Gear B engages Gear C, and conveys its power to the Pickup Roller Gear. The Swing Gear B engages Gear D, and conveys its power to the Exit Roller Gear.

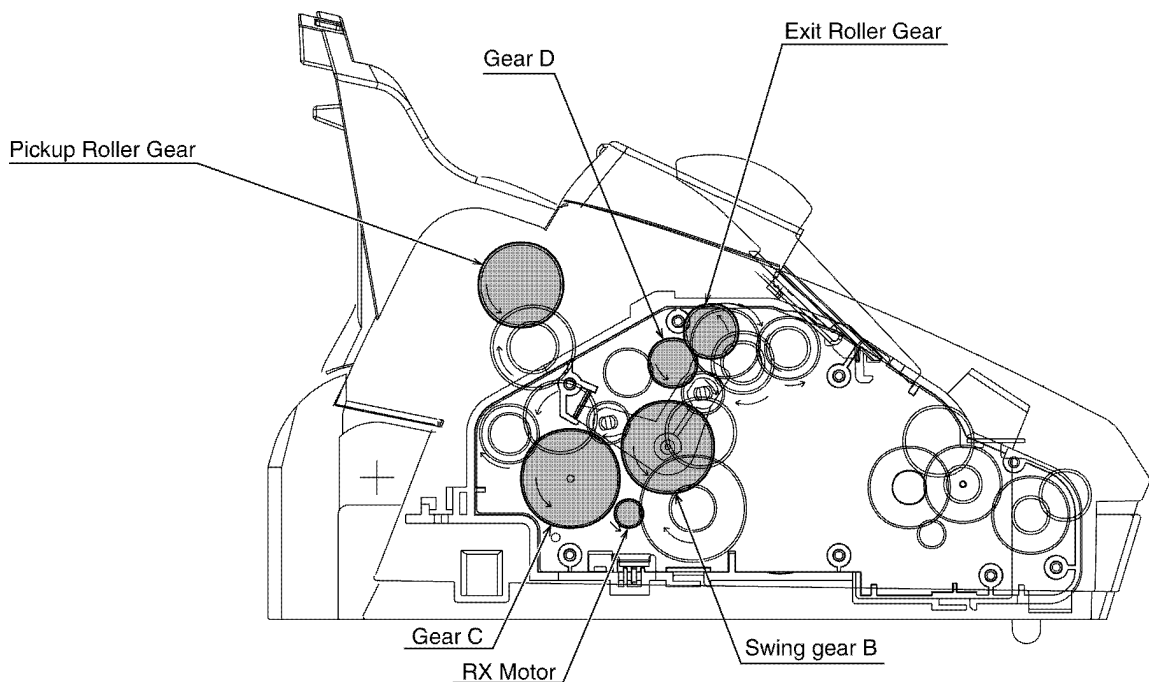

Fig. B: Paper Pickup / Paper Exit mode

### 4.2.1.3. PRINT MODE

The RX MOTOR rotate CW and Swing Gear B engages Gear F, and conveys its power to Platen Roller Gear and Ink Film Driver Gear.

The Swing Gear B engages Gear E, and conveys its power to the Exit Roller Gear.

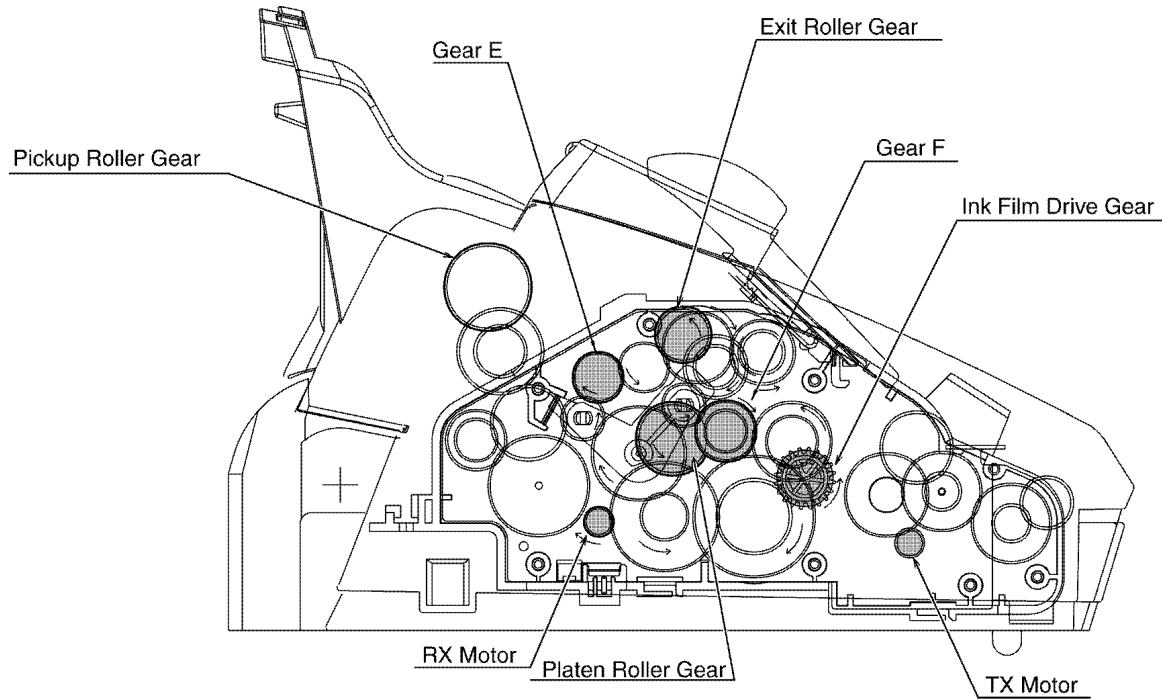

Fig. C: Print mode

### 4.2.1.4. COPY MODE

RX side: Paper Pickup mode → Print mode → Paper Exit mode.

TX side: Transmit mode.



## 4.3. JAMS

### 4.3.1. RECORDING PAPER JAMS

When the recording paper has jammed in the unit

The display will show the following.

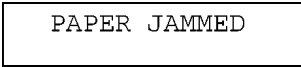

- 1 Open the front cover by pulling up the center part.

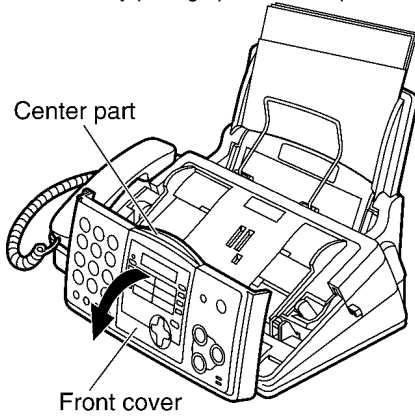

- 2 Push the back cover open button (green) on the right side of the unit.  
OR  
Push the back cover open lever (green) inside of the unit.

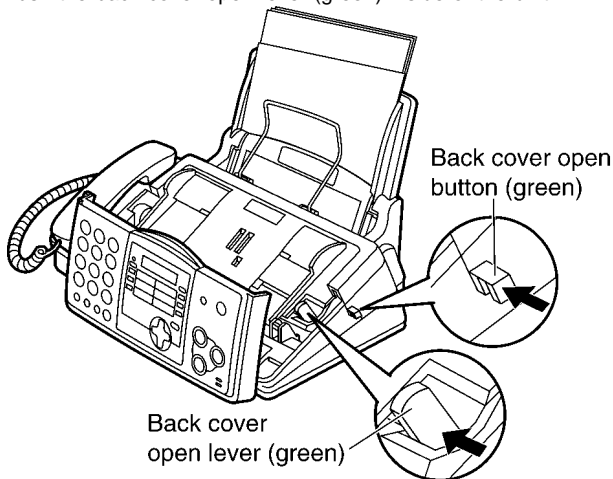

- 3 Open the back cover.

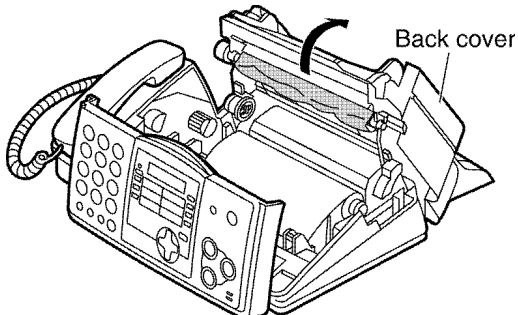

- 4 Remove the jammed recording paper.

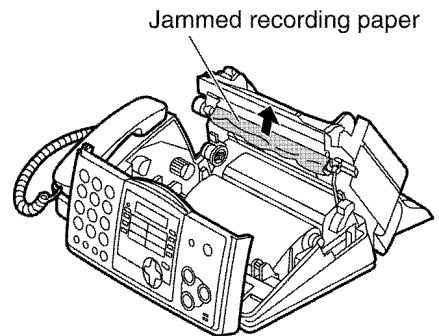

- 5 Turn the gear of blue core in the direction of the arrow.

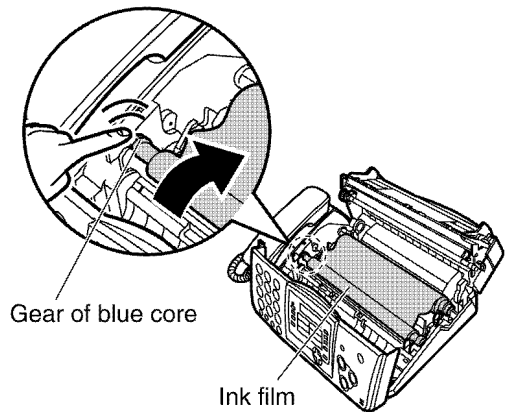

• Make sure that the ink film is wrapped around the blue core at least once.

**Correct**

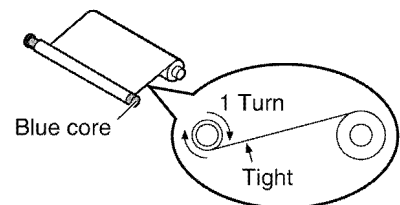

**Incorrect**

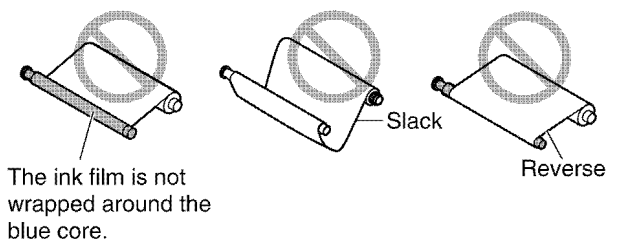

- 6 Close the back cover securely by pushing down on the dotted area at both ends (①). Close the front cover securely (②).

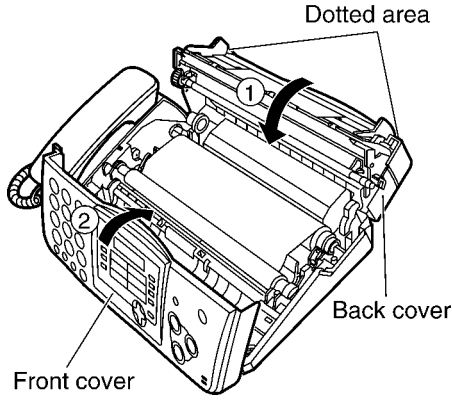

- 7 Remove the recording paper and straighten. Pull the tension plate forward and hold open while inserting the paper.

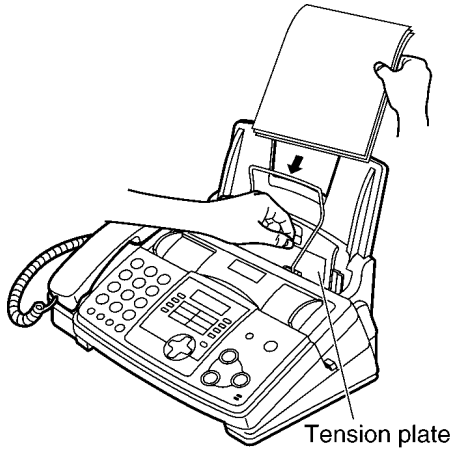

**When the recording paper was not fed into the unit properly**

The display will show the following.

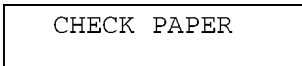

Remove the recording paper and straighten. Pull the tension plate forward and hold open while inserting the paper.

Press **[SET]** to clear the message.

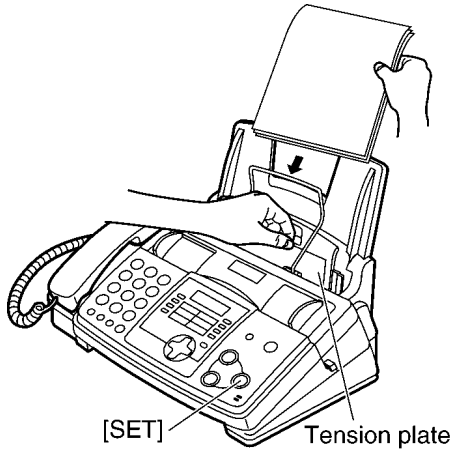

**4.3.2. DOCUMENT JAMS - SENDING**

- 1 Open the front cover by pulling up the center part. Remove the jammed document carefully.

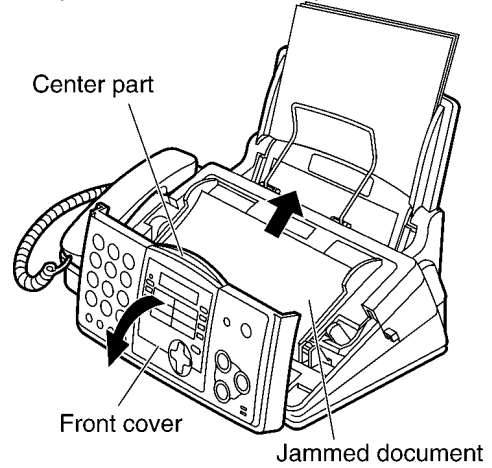

- 2 Close the front cover securely.

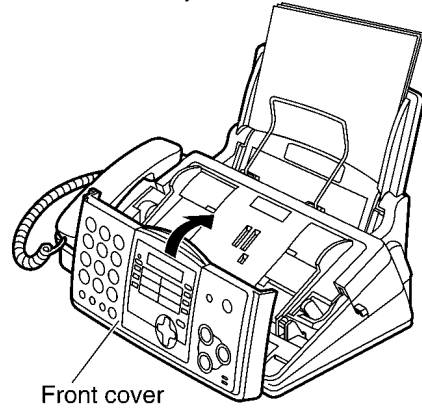

**Note:**

Do not pull out the jammed paper forcibly before opening the front cover.



## 4.4. CLEANING

### 4.4.1. DOCUMENT FEEDER

Clean the document feeder in the following cases:

- If misfeeding of the document occurs frequently.
- If smudges or black/white lines appear on the original document when transmitting or copying.

- 1 Disconnect the power cord and the telephone line cord.

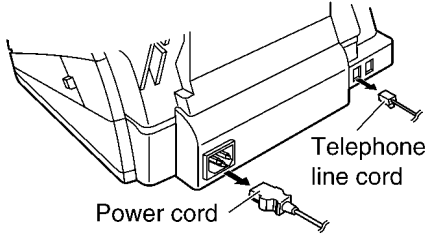

- 2 Open the front cover by pulling up the center part.

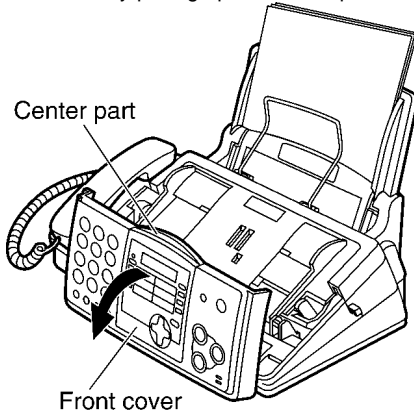

- 3 Clean the document feeder rollers and rubber flap with a cloth moistened with isopropyl rubbing alcohol, and let all parts dry thoroughly.

**Caution:**

Do not use paper products, such as paper towels or tissues.

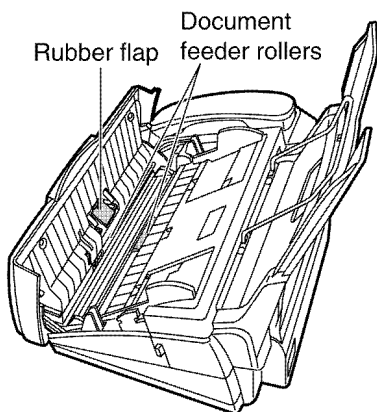

- 4 Clean the glass with a soft dry cloth.

**Caution:**

Do not use paper products, such as paper towels or tissues.

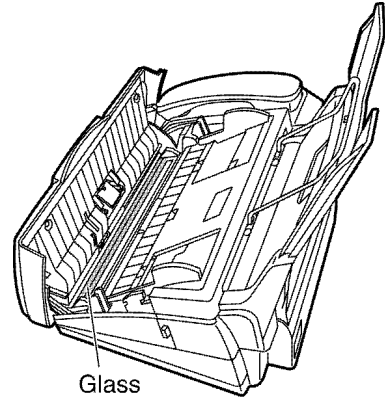

- 5 Close the front cover securely.

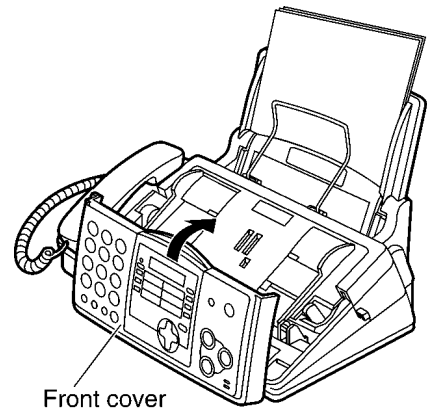

- 6 Connect the power cord and the telephone line cord.

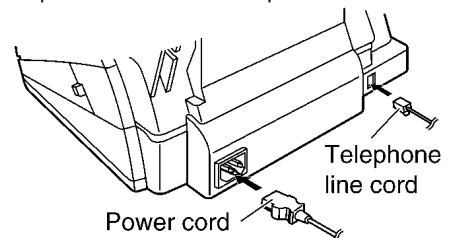

## 4.4.2. THERMAL HEAD

If smudges or black/white lines appear on a copied or received document, check whether there is dust on the thermal head and roller shaft, and clean the thermal head to remove the dust.

- 1 Disconnect the power cord and the telephone line cord.

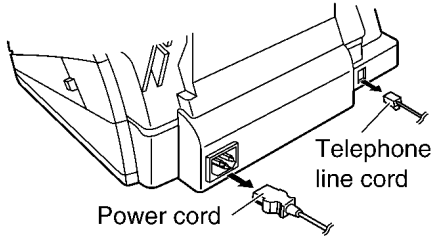

- 2 Open the front cover by pulling up the center part.

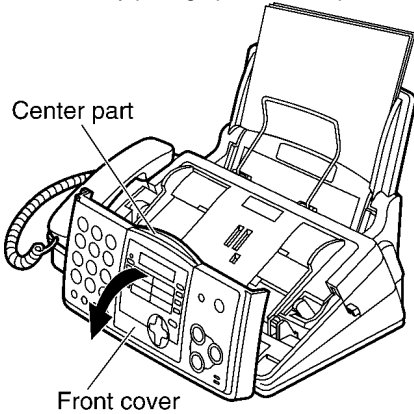

- 3 Push the back cover open button (green) on the right side of the unit.  
OR  
Push the back cover open lever (green) inside of the unit.

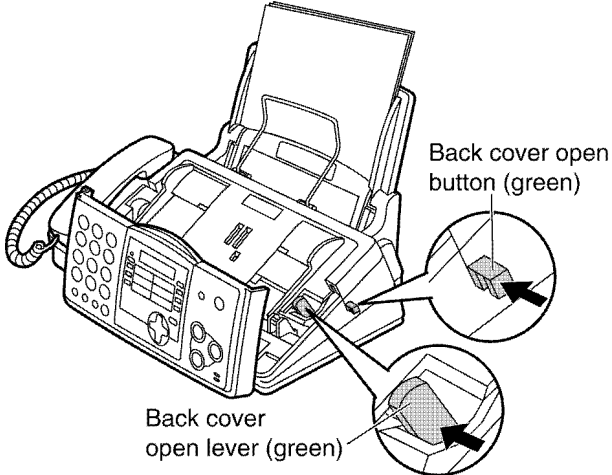

- 4 Open the back cover. Remove the ink film.

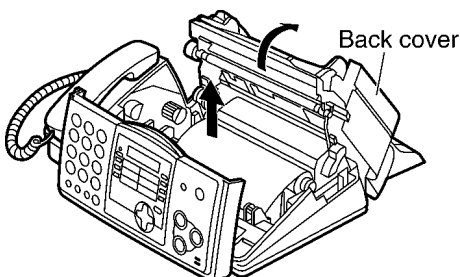

- 5 Clean the thermal head with a cloth moistened with isopropyl rubbing alcohol, and let it dry thoroughly.

**Caution:**

To prevent a malfunction due to static electricity, do not use a dry cloth and do not touch the thermal head directly.

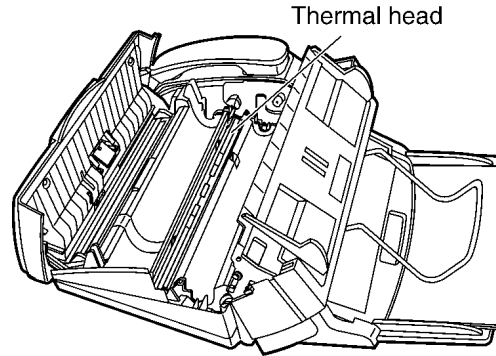

- 6 Replace the ink film.  
Turn the gear of blue core in the direction of the arrow.

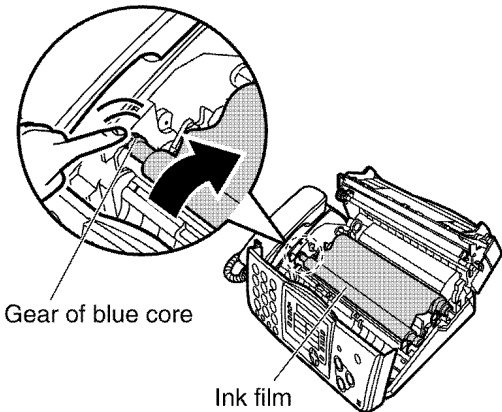

· Make sure that the ink film is wrapped around the blue core at least once.

**Correct**

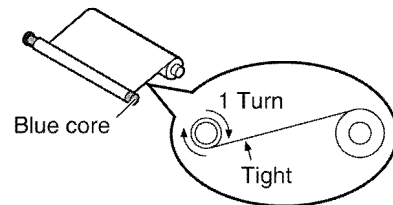

**Incorrect**

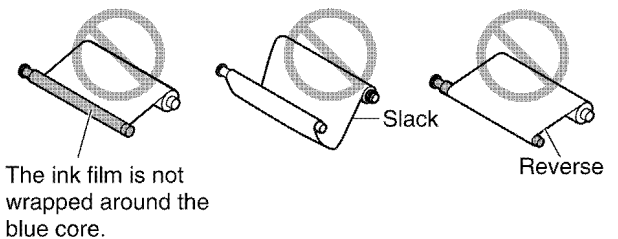

- 7 Close the back cover securely by pushing down on the dotted area at both ends (①). Close the front cover securely (②).

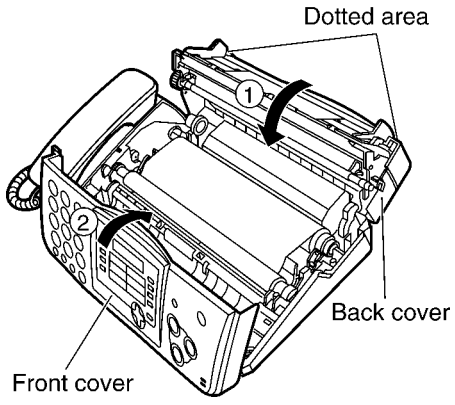

- 8 Connect the power cord and the telephone line cord.

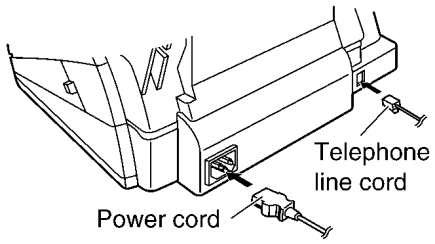

## 5 DISASSEMBLY INSTRUCTIONS

Before disassembling, remove the Ink film.

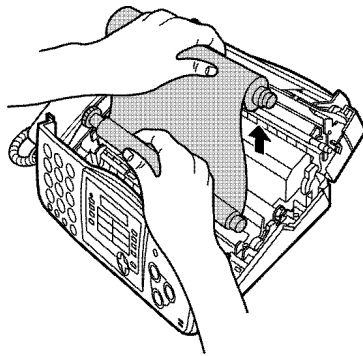

### 5.1. DISASSEMBLY FLOW CHART

#### 5.1.1. UPPER CABINET SECTION

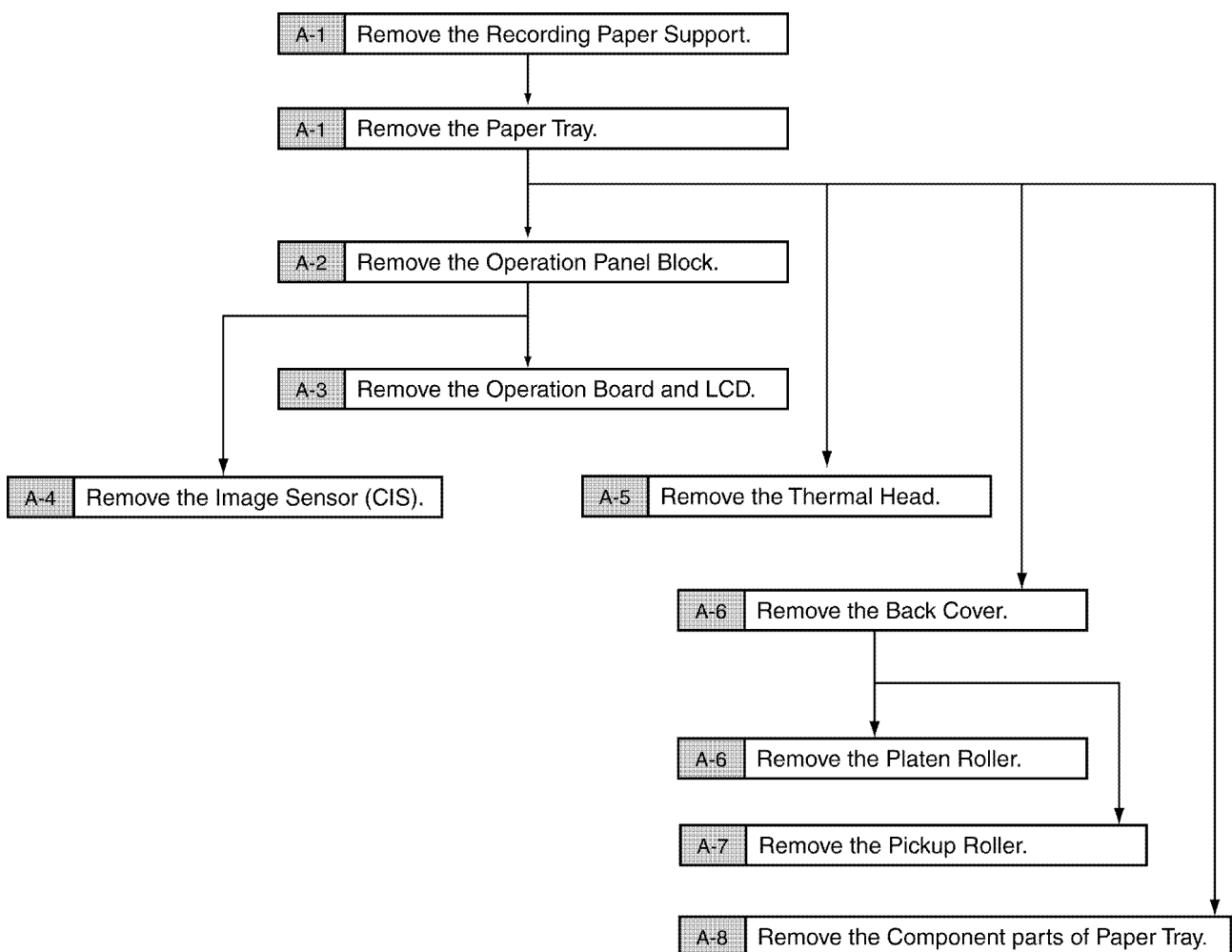

#### CROSS REFERENCE:

A-1 : HOW TO REMOVE THE PAPER TRAY AND RECORDING PAPER SUPPORT (P.32)

A-2 : HOW TO REMOVE THE OPERATION PANEL BLOCK (P.33)

A-3 : HOW TO REMOVE THE OPERATION BOARD AND LCD (P.34)

A-4 : HOW TO REMOVE THE IMAGE SENSOR (CIS) (P.35)

A-5 : HOW TO REMOVE THE THERMAL HEAD (P.36)

A-6 : HOW TO REMOVE THE PLATEN ROLLER AND BACK COVER (P.37)

A-7 : HOW TO REMOVE THE PICKUP ROLLER (P.38)

A-8 : HOW TO REMOVE THE CASSETTE LEVER (P.39)

## 5.1.2. LOWER CABINET SECTION

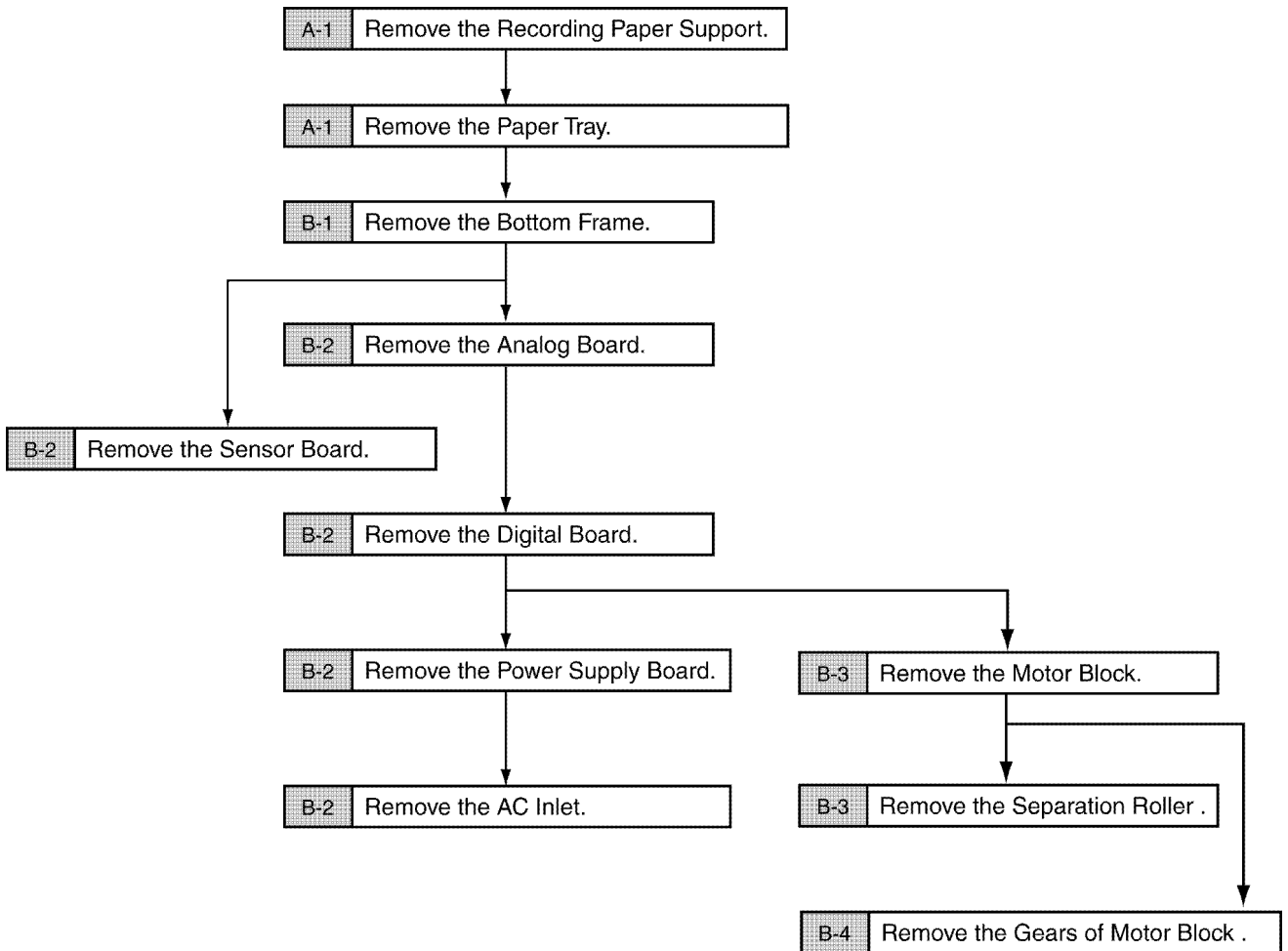

### CROSS REFERENCE:

**A-1 : HOW TO REMOVE THE PAPER TRAY AND RECORDING PAPER SUPPORT (P.32)**

**B-1 : HOW TO REMOVE THE BOTTOM FRAME (P.40)**

**B-2 : HOW TO REMOVE THE DIGITAL, ANALOG, POWER SUPPLY, SENSOR BOARDS AND AC INLET (P.41)**

**B-3 : HOW TO REMOVE THE MOTOR BLOCK AND SEPARATION ROLLER (P.42)**

**B-4 : HOW TO REMOVE THE GEARS OF MOTOR BLOCK (P.43)**

## 5.2. DISASSEMBLY PROCEDURE

### 5.2.1. HOW TO REMOVE THE PAPER TRAY AND RECORDING PAPER SUPPORT

**PROCEDURE: A-1**

Ref. No. A-1

- 1) Pull up and remove the RECORDING PAPER SUPPORT in the direction of the arrow.
- 2) Remove the PAPER TRAY in the direction of the arrow.

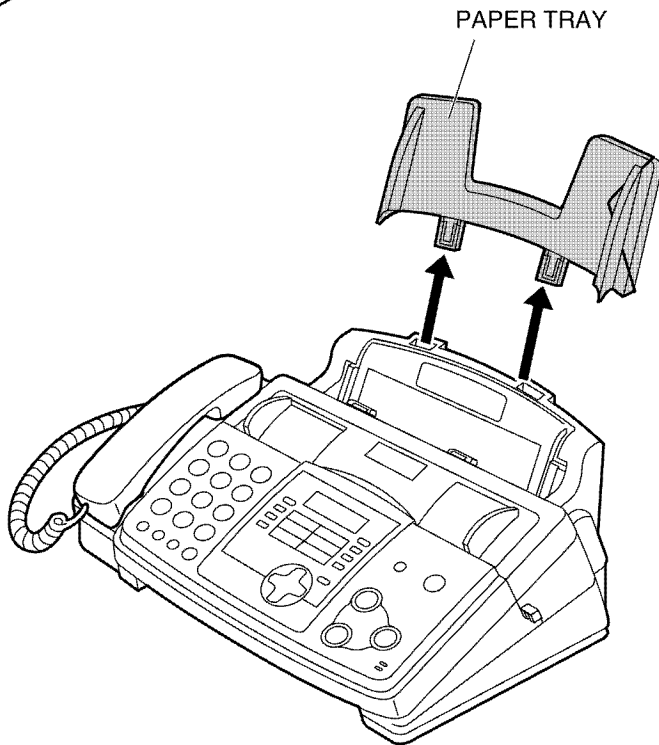
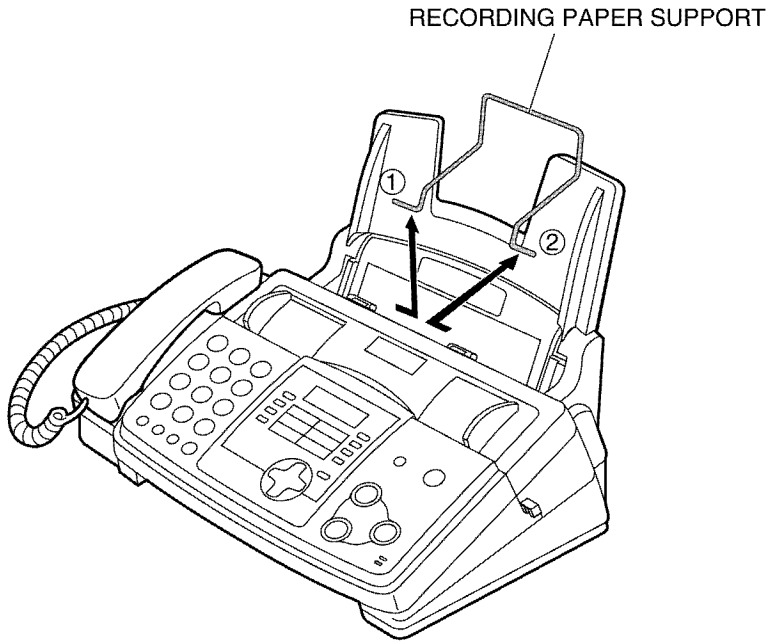



## 5.2.2. HOW TO REMOVE THE OPERATION PANEL BLOCK

PROCEDURE: A-1 --> B-1 --> A-2

Ref. No. A-2

- 1) Remove the SPRING from the RIB. (Ref No. B-1)
- 2) Unhook all the connectors connecting the main cabinet with the OPERATION PANEL BLOCK. (Ref No. B-1)
- 3) Open the OPERATION PANEL BLOCK by pulling up the center part.
- 4) Pull out both sides of the arms. (Fig. A)
- 5) Remove the OPERATION PANEL BLOCK.

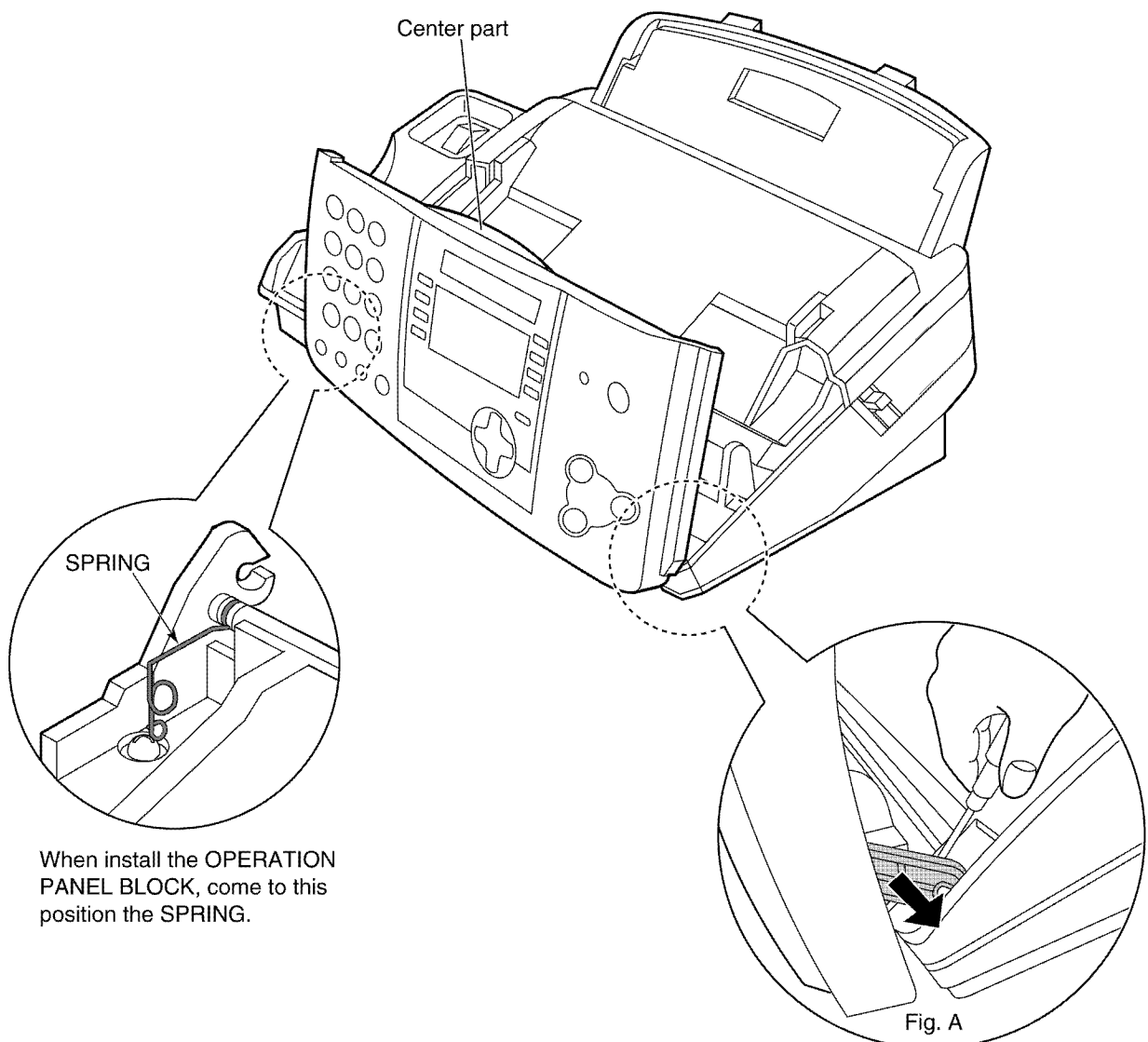

### 5.2.3. HOW TO REMOVE THE OPERATION BOARD AND LCD

**PROCEDURE: A-1 --> B-1 --> A-2 --> A-3**

**Ref. No. A-3**

- 1) Remove the 4 screws (A)-a.
- 2) Remove the OPERATION PANEL COVER.
- 3) Remove the 2 screws (A)-b.
- 4) Disconnect the CONNECTOR.
- 5) Remove the OPERATION BOARD.
- 6) Resolder the wire on the LCD.
- 7) Remove the LCD.

**CAUTION:**

When you set up, fasten these screws in order of number below.

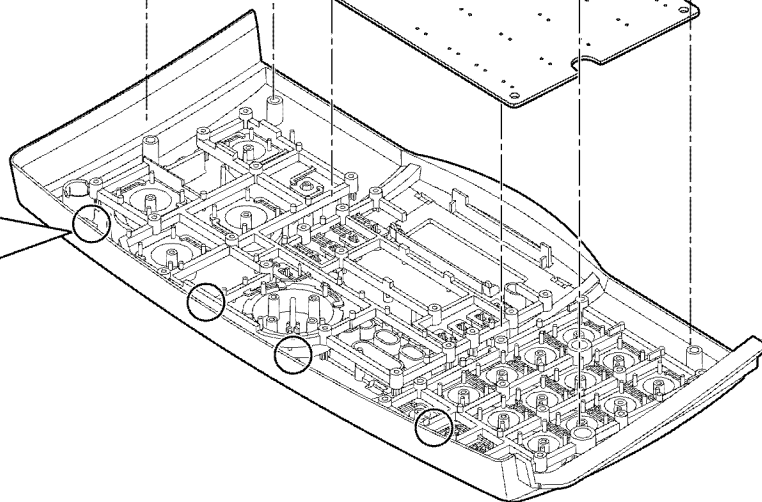
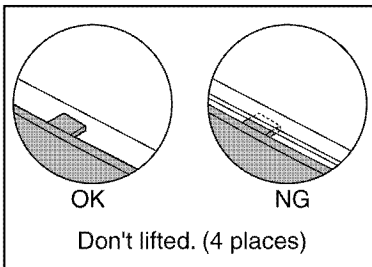
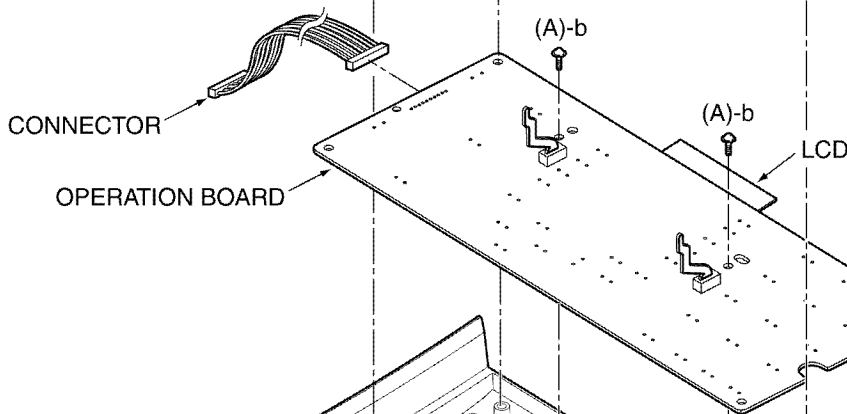
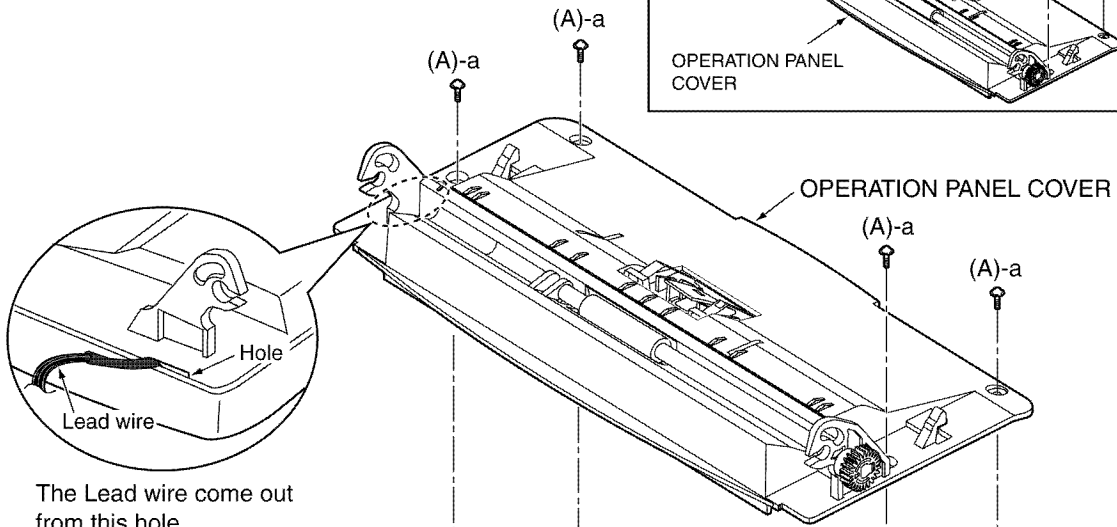
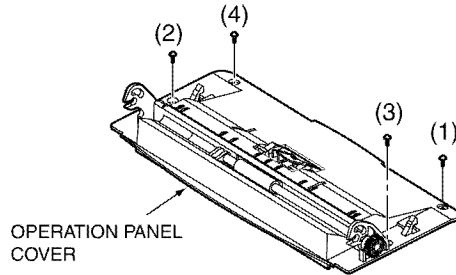

## 5.2.4. HOW TO REMOVE THE IMAGE SENSOR (CIS)

PROCEDURE: A-1 --> B-1 --> A-2 --> A-4

Ref. No. A-4

- 1) Remove the CONNECTOR.
- 2) Remove the IMAGE SENSOR (CIS). (Fig. A)

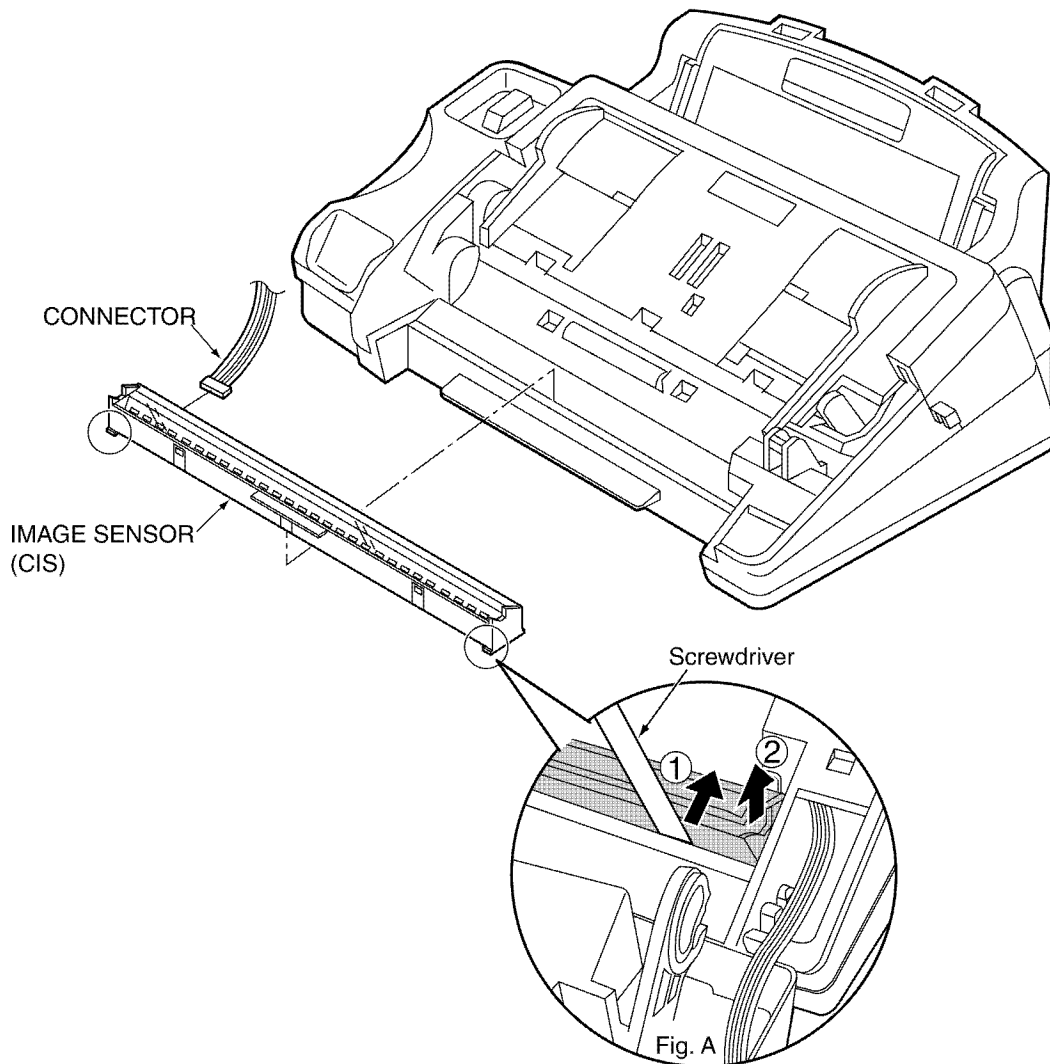

The another side is pickaped similarly.

## 5.2.5. HOW TO REMOVE THE THERMAL HEAD

**PROCEDURE: A-1 --> A-5**

**Ref. No. A-5**

- 1) Push the BACK COVER OPEN BUTTON to open back cover.
- 2) Remove the 2 GUIDEs (Fig. A) and CONNECTORs.
- 3) Remove the THERMAL HEAD.

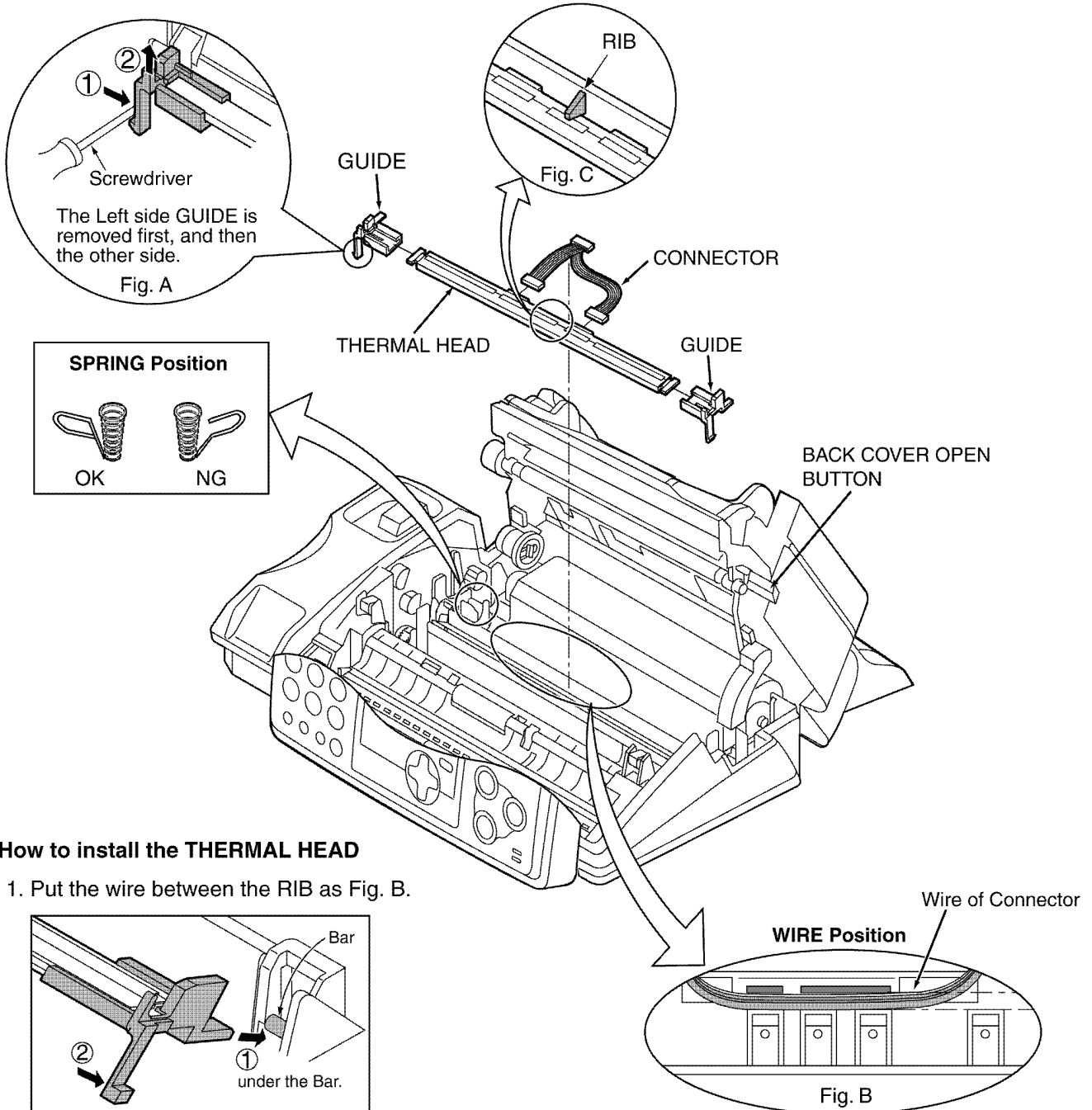

### • How to install the THERMAL HEAD

1. Put the wire between the RIB as Fig. B.

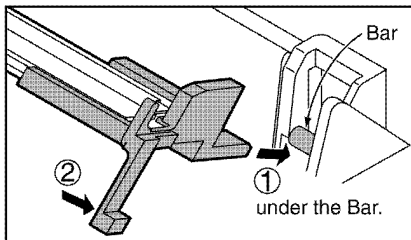

2. Insert the both sides GUIDE first as follows.
3. Put the THERMAL HEAD under the RIB as Fig. C.

## 5.2.6. HOW TO REMOVE THE PLATEN ROLLER AND BACK COVER

PROCEDURE: A-1 --> A-6

Ref. No. A-6

- 1) Push the BACK COVER OPEN BUTTON to open back cover.
- 2) Release the stopper. (Fig. A)
- 3) Push both side arms of the BACK COVER to outside, then move the cover up. (Fig. B, Fig. C)
- 4) Remove the BACK COVER.
- 5) Remove the GEAR and 2 SPACERS from the ribs as Fig. D.
- 6) Remove the PLATEN ROLLER.

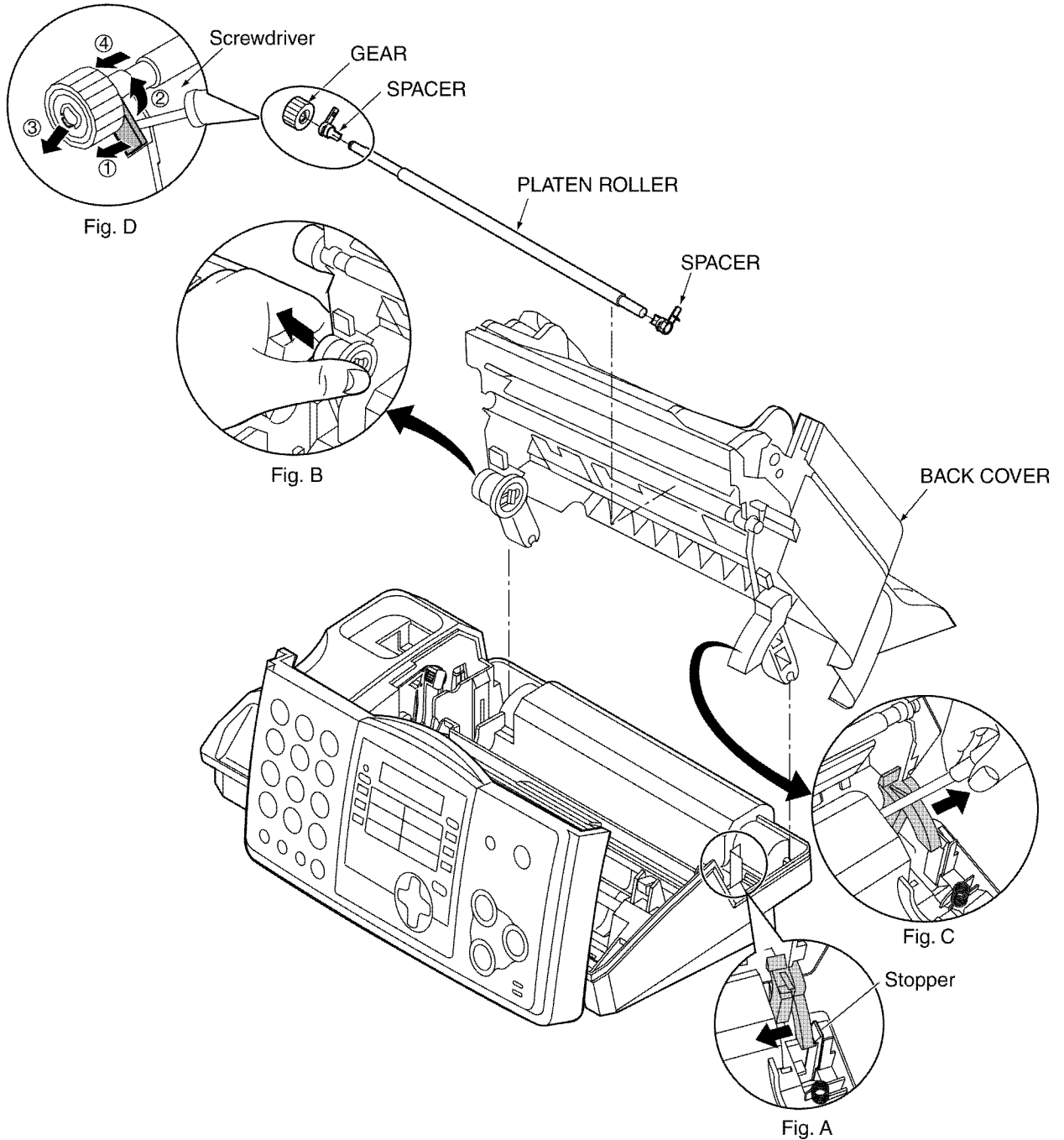

## 5.2.7. HOW TO REMOVE THE PICKUP ROLLER

PROCEDURE: A-1 --> A-6 --> A-7

Ref. No. A-7

- 1) Remove the 2 screws A-a.
- 2) Remove the COVER.
- 3) Remove the screws A-b.
- 4) Remove the 2 CORNER GUIDES.
- 5) Remove the GEAR.
- 6) Remove the PICKUP ROLLER.

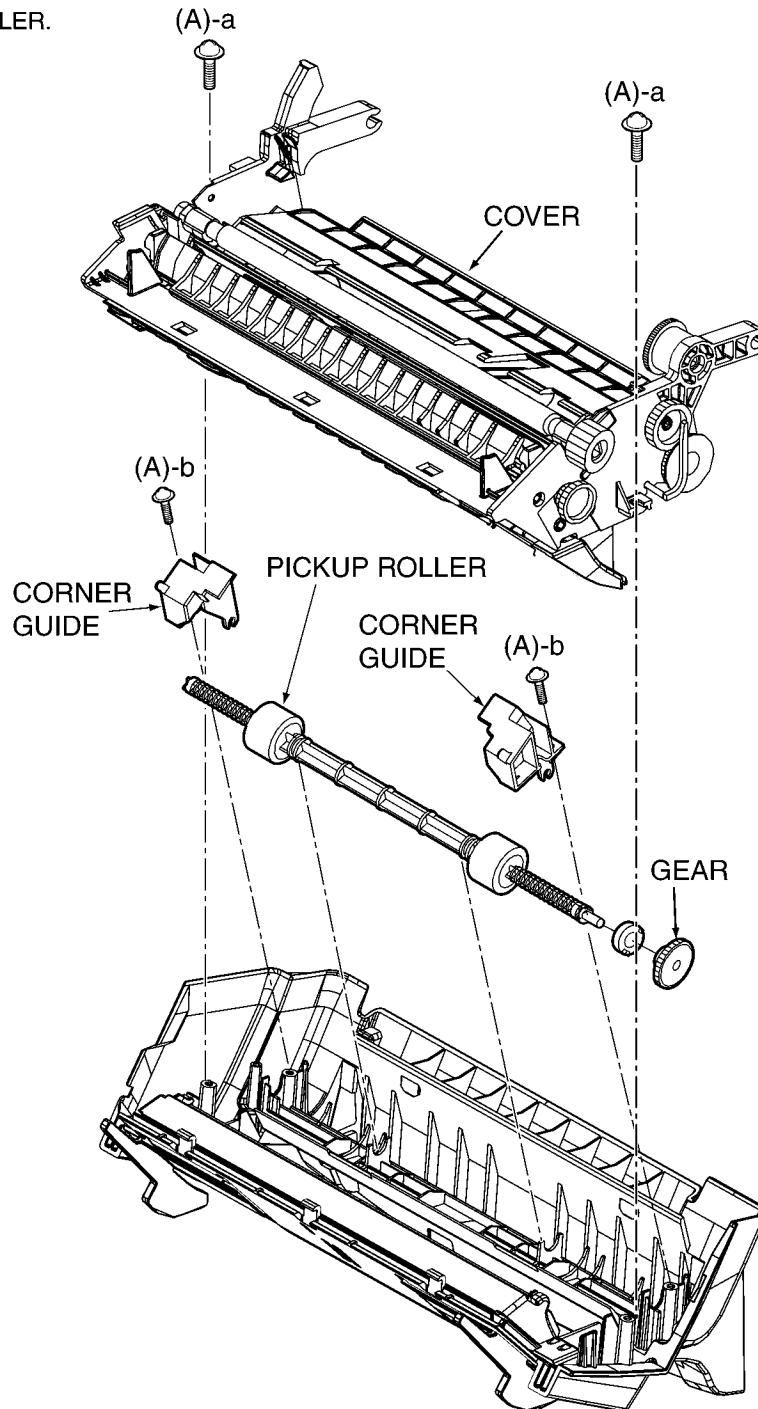

## 5.2.8. HOW TO REMOVE THE CASSETTE LEVER

PROCEDURE: A-1 --> A-6 --> A-8

Ref. No. A-8

- 1) Remove the 2 Springs.
- 2) Pull up and remove the CASSETTE LEVER.
- 3) Pull up and remove the CASSETTE PLATE (Fig. B).

**Note:** Inserting the CASSETTE PLATE the to unit, then insert the 2 Springs.

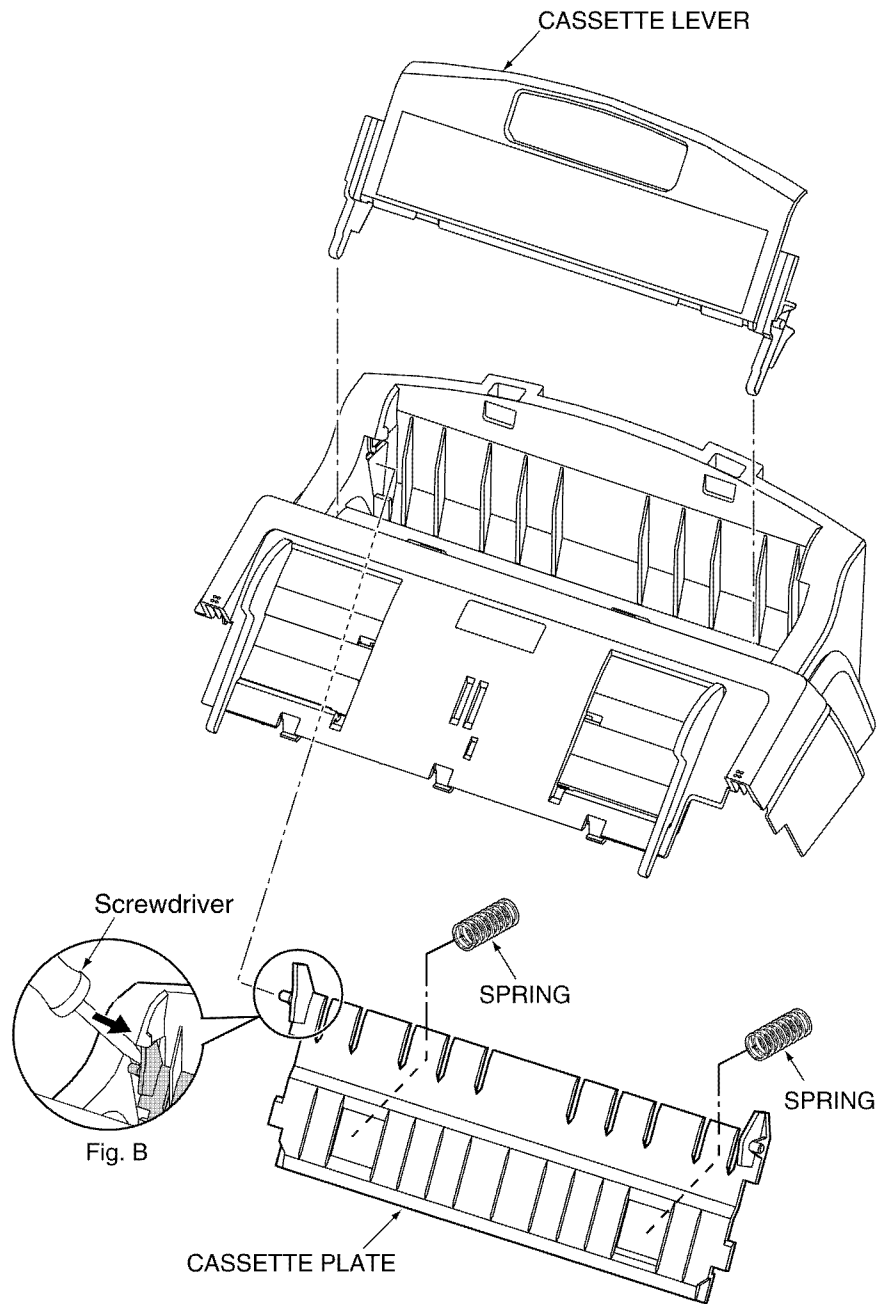

## 5.2.9. HOW TO REMOVE THE BOTTOM FRAME

PROCEDURE: A-1 --> B-1

Ref. No. B-1

- 1) Remove the 8 screws (A).
- 2) Remove the 1 screws (B).
- 3) Remove the SPRING from the RIB.
- 4) Remove the BOTTOM FRAME.

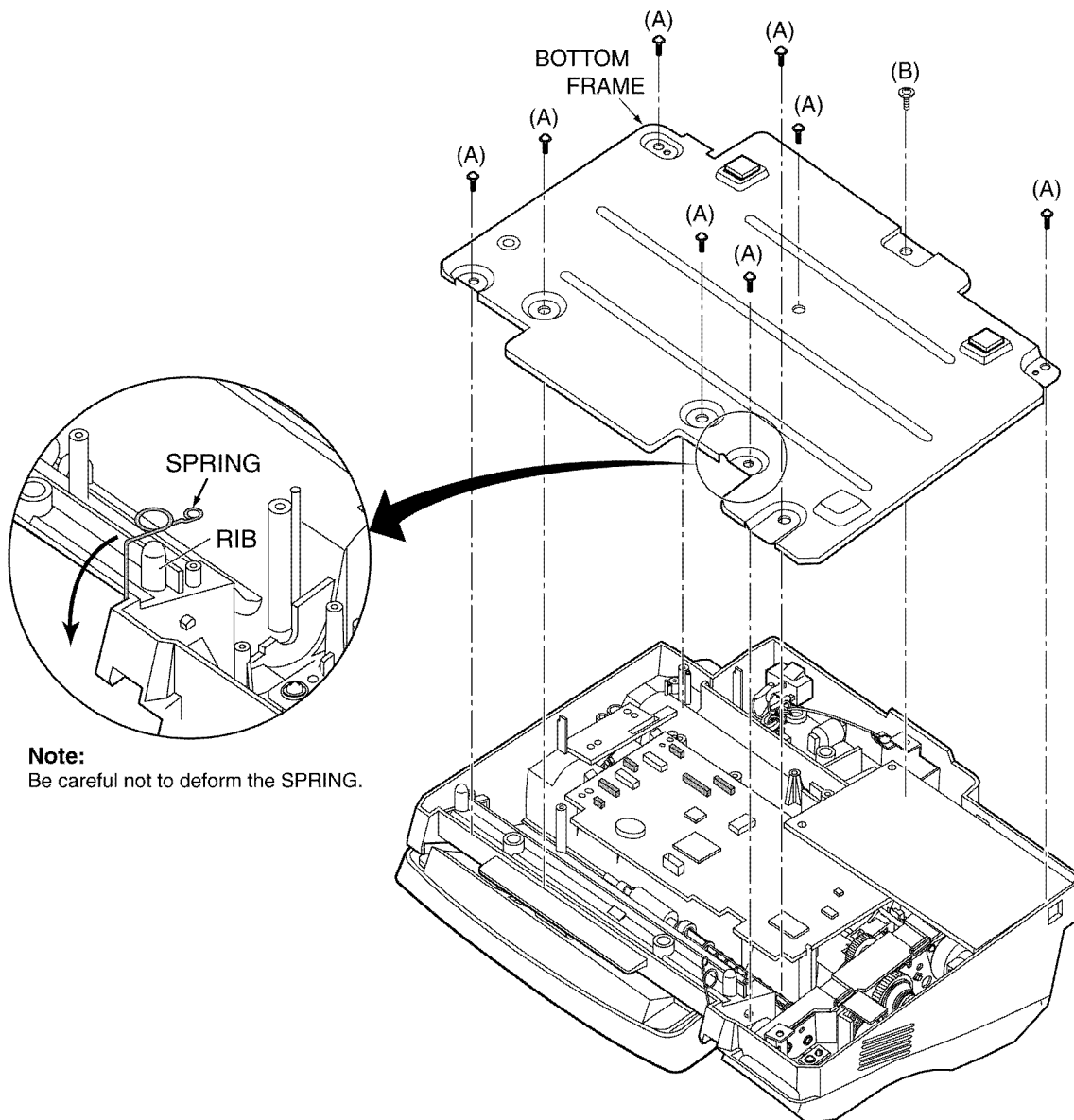

**Note:**

Be careful not to deform the SPRING.



## 5.2.10. HOW TO REMOVE THE DIGITAL, ANALOG, POWER SUPPLY, SENSOR BOARDS AND AC INLET

PROCEDURE: A-1 --> B-1 --> B-2

Ref. No. B-2

### <ANALOG / DIGITAL / POWER SUPPLY BOARD>

- 1) Remove the 2 screws (A)-a and 1 screw (C).
- 2) Disconnect the CONNECTOR-a.
- 3) Remove the ANALOG BOARD.
- 4) Disconnect the CONNECTORs-b.
- 5) Remove the 3 screws (A)-b.
- 6) Remove the DIGITAL BOARD.
- 7) Remove the 2 screws (A)-c and 1 screw (B).
- 8) Disconnect the CONNECTOR-c and CONNECTOR-d.
- 9) Remove the POWER SUPPLY BOARD.
- 10) Remove the AC INLET.

### <SENSOR BOARD>

- 1) Remove the 2 screws (A)-d.
- 2) Disconnect the CONNECTOR-e.
- 3) Remove the SENSOR BOARD.

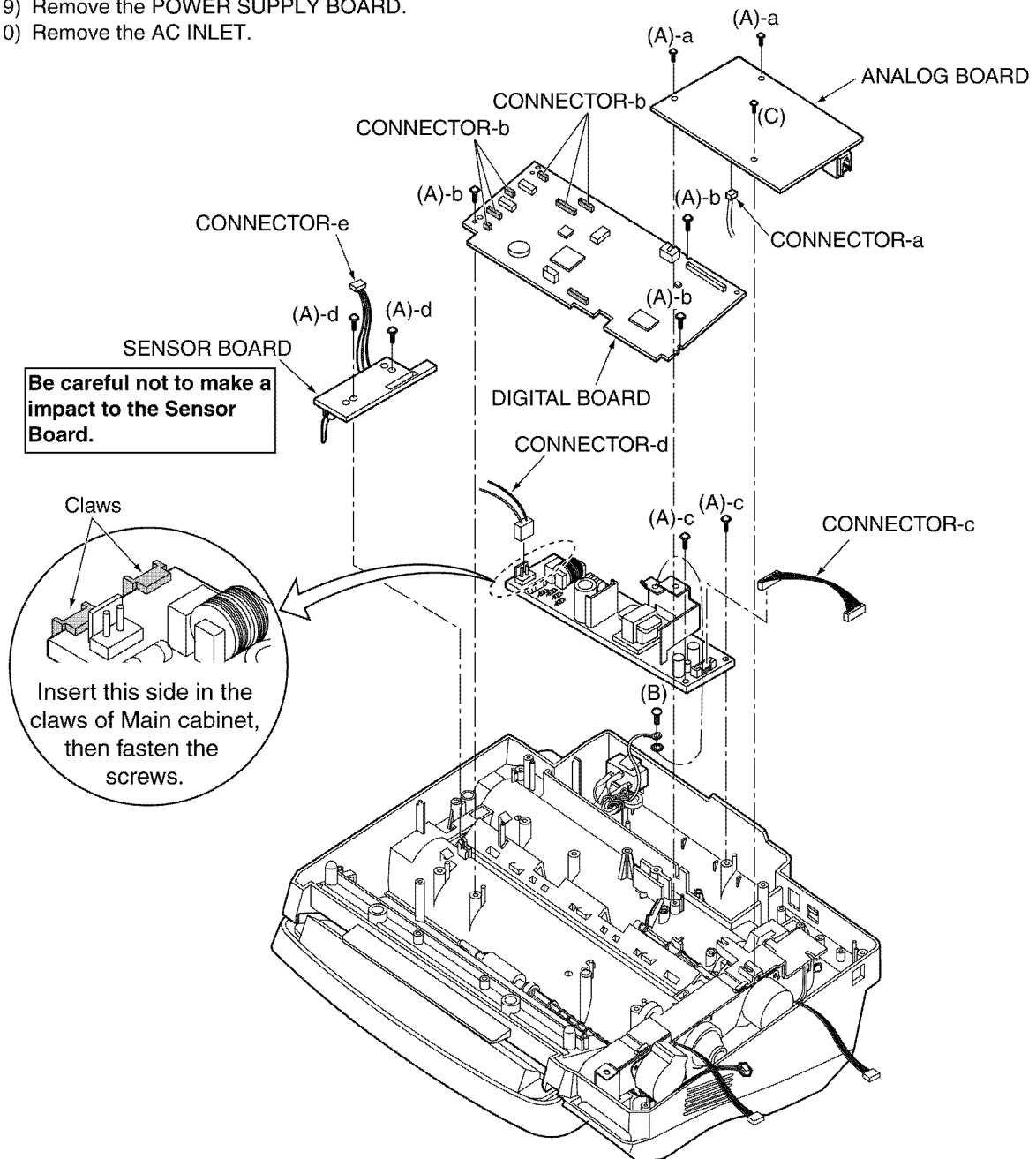

## 5.2.11. HOW TO REMOVE THE MOTOR BLOCK AND SEPARATION ROLLER

PROCEDURE: A-1 --> B-1 --> B-2 --> B-3

Ref. No. B-3

- 1) Remove the 4 screws (A).
- 2) Remove the MOTOR BLOCK.
- 3) Remove the SEPARATION ROLLER. (Fig. A)

**Note:**

When install the SEPARATION ROLLER, it inserted fully until the click is heard.

**CAUTION:**

When you set up, fasten these screws in order of number below.

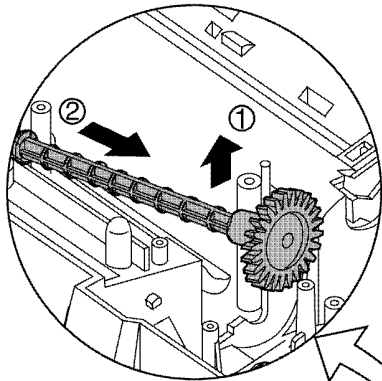
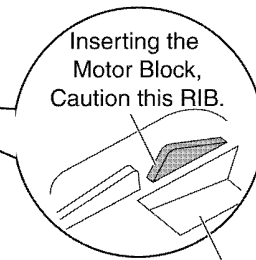
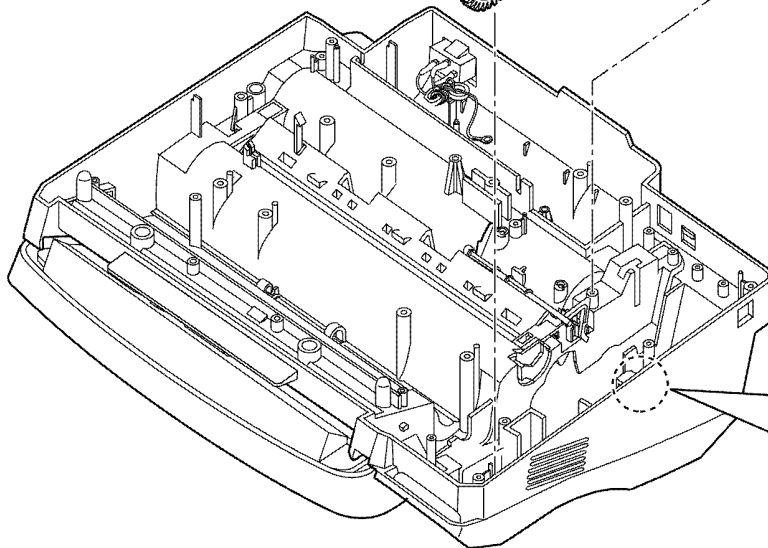
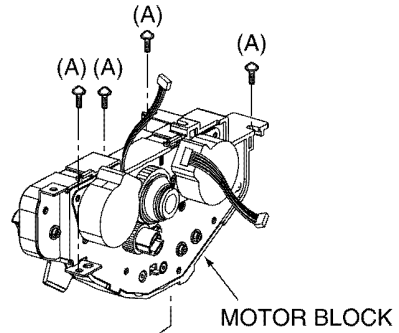
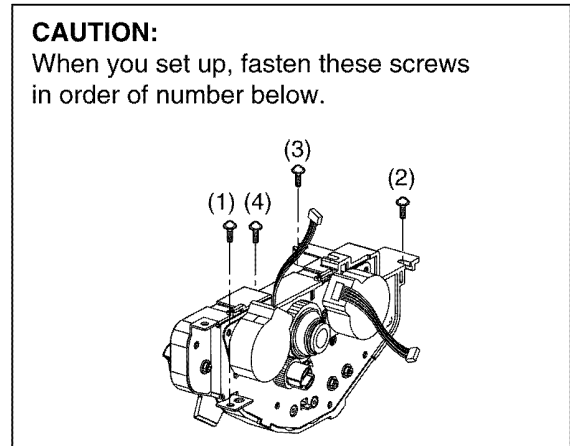
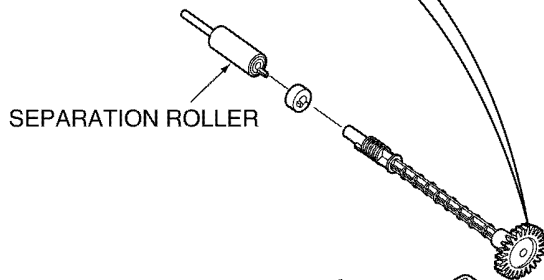

Fig. A



Hook Lever

## 5.2.12. HOW TO REMOVE THE GEARS OF MOTOR BLOCK

PROCEDURE: A-1 --> B-1 --> B-2 --> B-3 --> B-4

### Ref. No. B-4

- 1) Remove the 3 screws (D).
- 2) Unlock the claws with TORQUE LIMITTER (Gear), then pull the TORQUE LIMITTER (Shaft).
- 3) Remove the 2 MOTORS and FRAME.
- 4) Remove the GEAR-a.

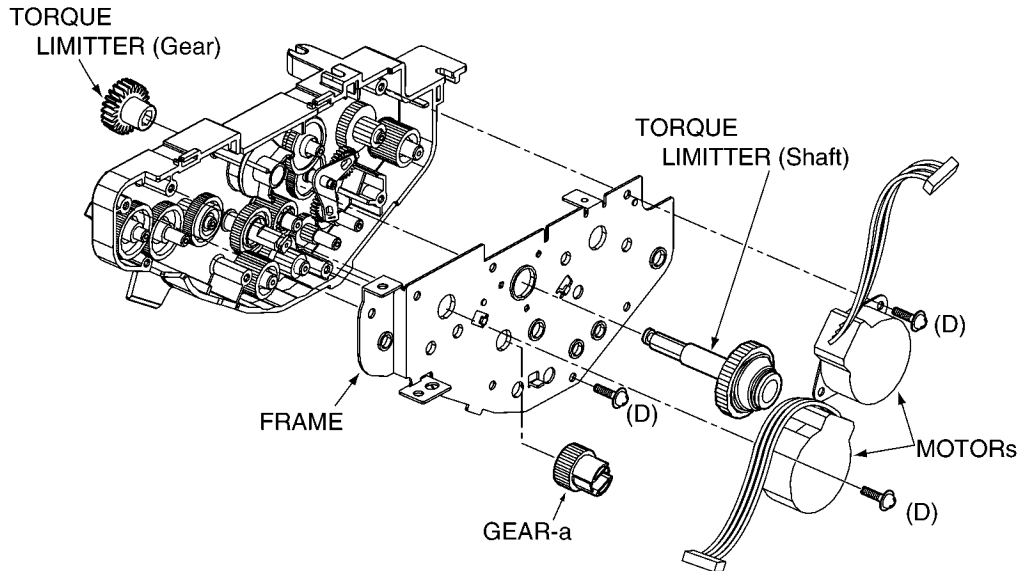

- 5) Remove the ARM Ass'y.
- 6) Remove the GEAR-b.
- 7) Remove the GEAR-c.
- 8) Remove the SUPPORT SPACER.
- 9) Remove the GEAR-d.
- 10) Remove the GEAR-e.
- 11) Remove the GEAR-f.
- 12) Remove the GEARS-g.
- 13) Remove the GEARS-h.
- 14) Remove the GEARS-i.

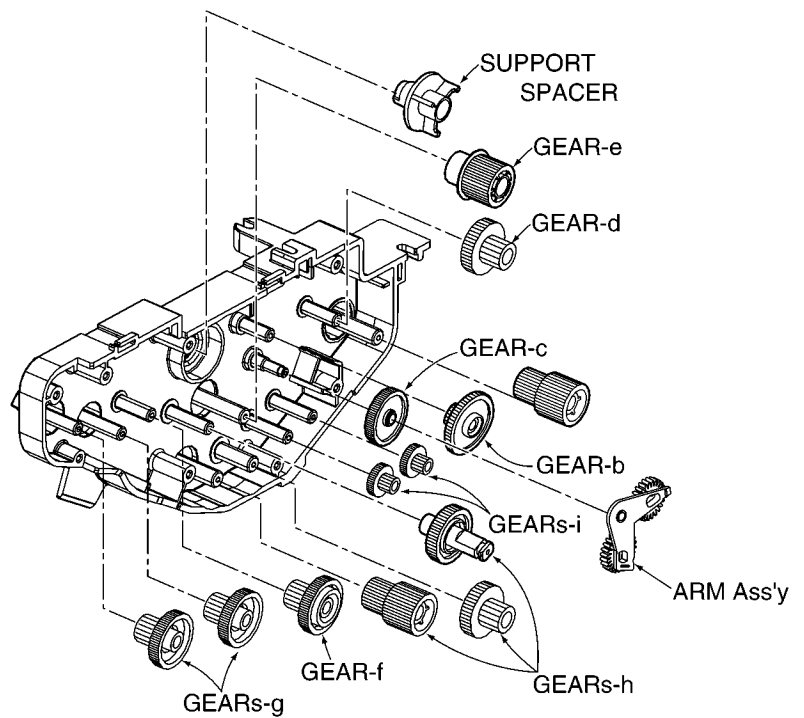

### 5.3. INSTALLATION POSITION OF THE LEAD WIRES

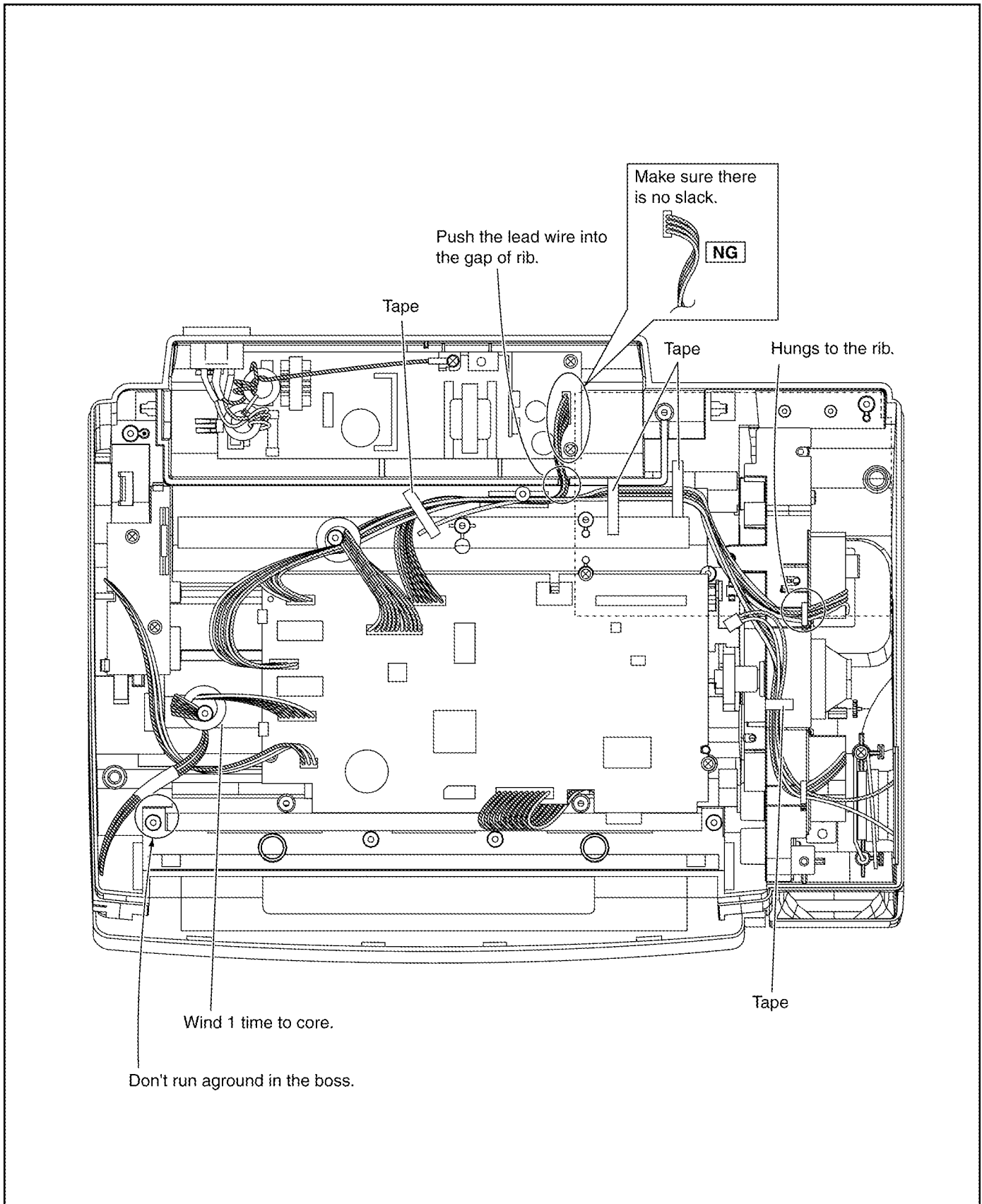

## 6 TROUBLESHOOTING GUIDE

### 6.1. USER RECOVERABLE ERRORS

If the unit detects a problem, one or more of the following messages will appear on the display.

The explanations given in the [ ] are for servicemen only.

CALL SERVICE

- There is something wrong with the unit.

CHECK DOCUMENT

- The document was not fed into the unit properly. Reinsert the document. If misfeeding occurs frequently, clean the document feeder rollers and try again. (Refer to **DOCUMENT FEEDER** (P.27).)
- Attempted to transmit a document longer than 600 mm. Press the **[STOP]** to remove the document. Divide the document into two or more sheets and try again.
- [Alternately, turn off service code #559 to enable sending of documents longer than 600 mm] (Refer to **SERVICE FUNCTION TABLE** (P.48).)

CHECK MEMORY

- The memory (telephone numbers, parameters, etc.) has been erased. Re-program.

[The backup lithium battery on the top of the digital board may be low or dead, so check it.]

CHECK PAPER

- The recording paper is not installed or the unit has run out of paper. Install paper and press **[SET]** to clear the message.
- The recording paper is not fed into the unit properly. Reinstall paper and press **[SET]** to clear the message. (Refer to **INSTALLING THE RECORDING PAPER** (P.16).)
- The recording paper has jammed near the recording paper entrance. Clear the jammed paper and press **[SET]** to clear the message. Do not install folded or heavily curled paper. (Refer to **RECORDING PAPER JAMS** (P.25).)

COVER OPEN

- The back cover is open. Close it.

DIRECTORY FULL

- There is no space to store new entries in navigator directory. Erase unnecessary entries.

FAX IN MEMORY

- The unit has a document in memory. See the other displayed message instructions to print out the document.

FAX MEMORY FULL

- The memory is full of received documents due to lack of recording paper or a recording paper jam. Install paper or clear the jammed paper. (Refer to **RECORDING PAPER JAMS** (P.25).)
- When performing memory transmission, the document being stored exceeds the memory capacity of the unit. Transmit the entire document manually.

FILM EMPTY

- The film is empty. Replace the film with a new one. (Refer to **INSTALLING THE INK FILM** (P.15).)
- The ink film is slack. Tighten it and install again. (Refer to **RECORDING PAPER JAMS** (P.25).)

FILM NEAR EMPTY

- The remaining film is low. Prepare a new film. (Refer to **INSTALLING THE INK FILM** (P.15).)

MEMORY FULL

- When making a copy, the document being stored exceeds the memory capacity of the unit. Press **[STOP]** to clear the message. Divide the document into sections.

MODEM ERROR

- There is something wrong with the modem circuit.

TRANSMIT ERROR

- A transmission error occurred. Try again.

NO FAX REPLY

- The other party's fax machine is busy or has run out of recording paper. Try again.

UNIT OVERHEATED

- The unit is too hot. Let the unit cool down.

OPEN CABINET  
CHECK FILM SLACK



OPEN CABINET  
CHECK FILM TYPE

- The ink film is empty. Replace the ink film with a new one.
- The ink film is not installed. Install it.  
Refer to **INSTALLING THE INK FILM** (P.15).
- The ink film is slack. Tighten it.

PAPER JAMMED

- A recording paper jam occurred. Clear the jammed paper.  
[If the printout jams, please refer to **RECORDING PAPER JAMS** (P.25).]

PLEASE WAIT

- The unit is checking that there is no slack on the ink film. Wait for a moment while the check completes.

REDIAL TIME OUT

- The other party's fax machine is busy or has run out of recording paper. Try again.

REMOVE DOCUMENT

- The document is jammed. Remove the jammed document. (Refer to **DOCUMENT JAMS - SENDING** (P.26).)

## 6.2. PROGRAMMING AND LISTS

The programming functions are used to program the various features and functions of the machine, and to test the machine. This facilitates communication between the user and the service man while programming the unit.

### 6.2.1. OPERATION

There are 2 basic categories of programming functions, the User Mode and the Service Mode. The Service Mode is further broken down into the normal and special programs. The normal programs are those listed in the Operating Instructions and are available to the user. The special programs are only those listed here and not displayed to the user. In both the User and Service Modes, there are Set Functions and Test Functions. The Set Functions are used to program various features and functions, and the Test Functions are used to test the various functions. The Set Functions are accessed by entering their code, changing the appropriate value, then pressing the SET key. The Test Functions are accessed by entering their code and pressing the key listed on the menu. While programming, to cancel any entry, press the STOP key.

### 6.2.2. OPERATION FLOW

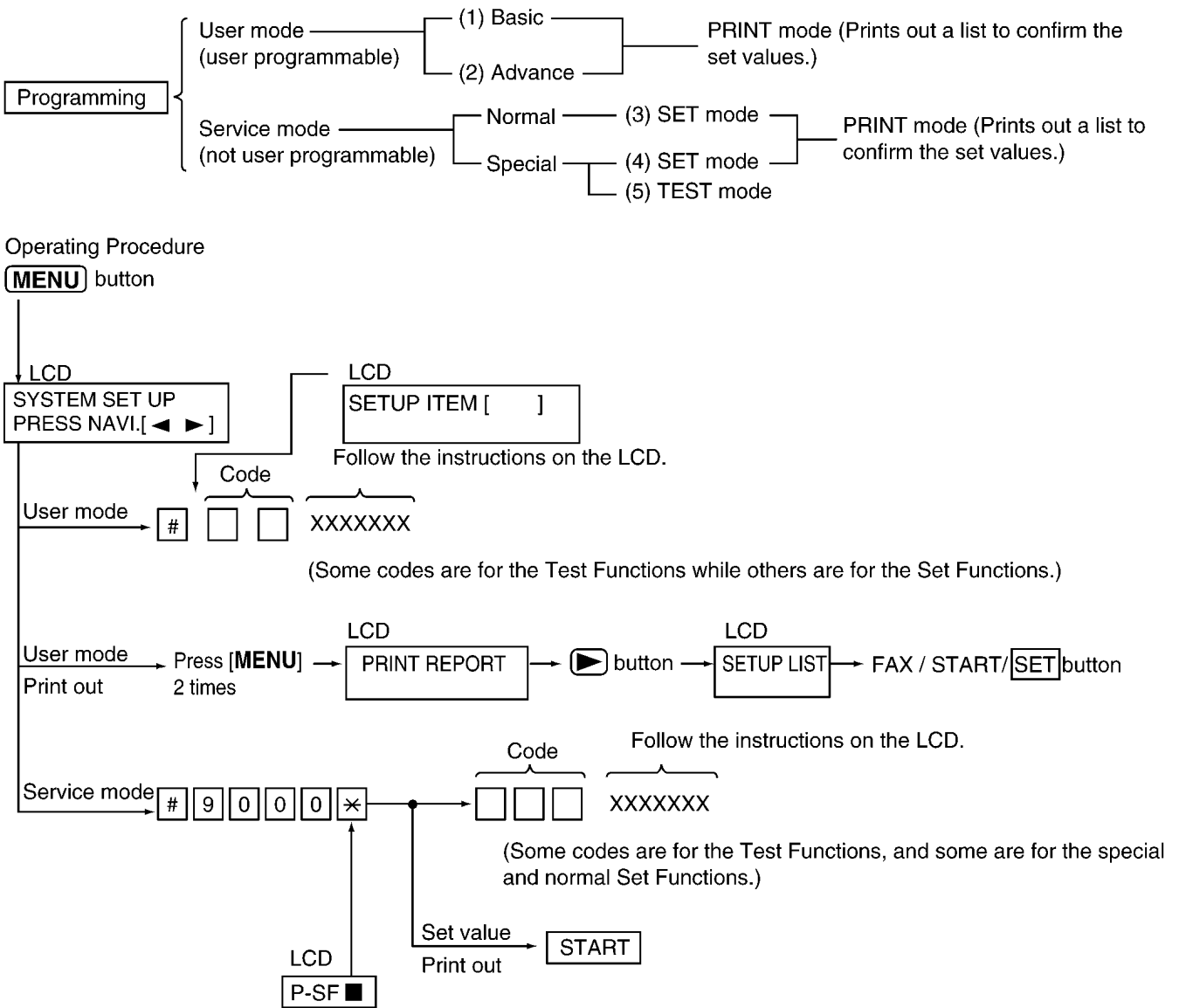

### 6.2.3. SERVICE FUNCTION TABLE

Code	Function	Set Value	Effective Range	Default	Remarks
501	Pause time set	X 100 msec	001~600	30	-----
502	Flash time	X 10 ms	01~99	70	-----
503	Dial speed select	1: 10 pps 2: 20 pps	1, 2	1	-----
511	VOX sense	1:High 2:Low	1, 2	1	When the TAM (or EXT TAM) does not stop recording the ICM because noise is detected on the telephone line, change this setting to "LOW".
514	Bell detection time	X100msec	1~9	6	-----
520	CED frequency select	1:2100 Hz 2:1100 Hz	1, 2	1	See Symptom/Countermeasure Table for long distance and international calls in <b>THE UNIT CAN COPY, BUT CANNOT EITHER TRANSMIT/RECEIVE LONG DISTANCE OR INTERNATIONAL COMMUNICATIONS (P.79).</b>
521	International mode select	1:ON 2:OFF	1, 2	1	See Symptom/Countermeasure Table for long distance and international calls in <b>THE UNIT CAN COPY, BUT CANNOT EITHER TRANSMIT/RECEIVE LONG DISTANCE OR INTERNATIONAL COMMUNICATIONS (P.79).</b>
522	Auto standby select	1:ON 2:OFF	1, 2	1	The resolution reverts to the default when transmission is complete.
523	Receive equalizer select	1: 0 km 2: 1.8 km 3: 3.6 km 4: 7.2 km	1~4	1	When the telephone station is far from the unit or reception cannot be performed correctly, adjust accordingly.
524	Transmission equalizer select	1: 0 km 2: 1.8 km 3: 3.6 km 4: 7.2 km	1~4	1	When the telephone station is far from the unit or transmission cannot be performed correctly, adjust accordingly.
550	Memory clear				See <b>TEST FUNCTIONS (P.50).</b>
551	ROM check				See <b>TEST FUNCTIONS (P.50).</b>
552	DTMF single tone test	1:ON 2:OFF	1, 2	2	See <b>TEST FUNCTIONS (P.50).</b>
553	Monitor on FAX communication select	1:OFF 2:PHASE B 3:ALL	1~3	1	Sets whether to monitor the line signal with the unit's speaker during FAX communication or not.
554	Modem test				See <b>TEST FUNCTIONS (P.50).</b>
555	Scan check				See <b>TEST FUNCTIONS (P.50).</b>
556	Motor test			0	See <b>TEST FUNCTIONS (P.50).</b>
557	LED test				See <b>TEST FUNCTIONS (P.50).</b>
558	LCD test				See <b>TEST FUNCTIONS (P.50).</b>
559	Document jam detection select	1:ON 2:OFF	1, 2	1	See <b>DOCUMENT JAMS - SENDING (P.26).</b>
561	KEY test				See <b>TEST FUNCTIONS (P.50).</b>
570	BREAK % select	1:61% 2:67%	1, 2	1	Sets the % break of pulse dialing according PBX.
571	ITS auto redial time set	X number of times	00~99	05	Selects the number of times that ITS is redialed (not including the first dial).
572	ITS auto redial line disconnection time set	X second	001~999	065	Sets the interval of ITS redialing.
573	Remote turn-on ring number set	X number of rings	01~99	10	Sets the number of rings before the unit starts to receive a document in the TEL mode.
590	FAX auto redial time set	X number of times	00~99	05	Selects the number of redial times during FAX communication (not including the first dial).
591	FAX auto redial time disconnection time set	X second	001~999	065	Sets the FAX redial interval during FAX communication.
592	CNG transmit select	1:OFF 2:ALL 3:AUTO	1~3	2	Lets you select the CNG output during FAX transmission. ALL: CNG is output at phase A. AUTO: CNG id output only when automatic dialing is performed. OFF: CNG id not output at phase A. Refer to <b>SOMETIME THERE IS A TRANSMIT PROBLEM (P.77).</b>
593	Time between CED and 300bps	1:75 msec 2:500 msec 3:1 sec	1~3	1	See <b>Symptom/Countermeasure Table</b> for long distance and international calls in <b>THE UNIT CAN COPY, BUT CANNOT EITHER TRANSMIT/RECEIVE LONG DISTANCE OR INTERNATIONAL COMMUNICATIONS (P.79).</b> Refer to <b>RECEIVE PROBLEM (P.78)</b> and <b>THE UNIT CAN COPY, BUT CANNOT EITHER TRANSMIT/RECEIVE LONG DISTANCE OR INTERNATIONAL COMMUNICATIONS (P.79).</b>



Code	Function	Set Value	Effective Range	Default	Remarks
594	Overseas DIS detection select	1:detects at the 1st time 2:detects at the 2st time	1, 2	1	See <b>Symptom/Countermeasure Table</b> for long distance and international calls in <b>THE UNIT CAN COPY, BUT CANNOT EITHER TRANSMIT/RECEIVE LONG DISTANCE OR INTERNATIONAL COMMUNICATIONS (P.79)</b> . Refer to <b>SOMETIME THERE IS A TRANSMIT PROBLEM (P.77)</b> and <b>THE UNIT CAN COPY, BUT CANNOT EITHER TRANSMIT/RECEIVE LONG DISTANCE OR INTERNATIONAL COMMUNICATIONS (P.79)</b> .
595	Receive error limit value set	X Number of times	001~999	100	Sets the number of acceptable error lines when the FAX reconstructs the received data. Refer to <b>RECEIVE PROBLEM (P.78)</b> .
596	Transmit level set	X dBm	- 15~00	10	Selects the FAX transmission level. Refer to <b>SOMETIME THERE IS A TRANSMIT PROBLEM (P.77)</b> and <b>RECEIVE PROBLEM (P.78)</b> .
598	Receiving sensitivity	43= -43 dBm	20~48	40	Used when there is an error problem. Refer to <b>THE UNIT CAN COPY, BUT CANNOT EITHER TRANSMIT/RECEIVE LONG DISTANCE OR INTERNATIONAL COMMUNICATIONS (P.79)</b> .
700	EXT.TAM OGM Rec. time	X second	01~99	10	Sets the start time of silent detection.
701	No voice detect time	X100 msec	01~99	50	Sets the silent call confirmation detection time.
717	Transmit speed selection	1:9600BPS 2:7200BPS 3:4800BPS 4:2400BPS	1~4	1	Adjusts the speed to start training during FAX transmission. Refer to <b>SOMETIME THERE IS A TRANSMIT PROBLEM (P.77)</b> and <b>THE UNIT CAN COPY, BUT THE TRANSMISSION AND RECEPTION IMAGE ARE INCORRECT (P.82)</b> .
718	Receive speed selection	1:9600BPS 2:7200BPS 3:4800BPS 4:2400BPS	1~4	1	Adjusts the speed to start training during FAX reception. Refer to <b>RECEIVE PROBLEM (P.78)</b> and <b>THE UNIT CAN COPY, BUT THE TRANSMISSION AND RECEPTION IMAGE ARE INCORRECT (P.82)</b> .
722	Redial tone detect	1:ON 2:OFF	1, 2	1	Sets the tone detection mode after redialing.
745	Power ON film feed	1:ON 2:OFF	1, 2	1	When the power is turned on, the film is wound to take up any slack.
763	CNG detect time for friendly reception	1:10 sec 2:20 sec 3:30 sec	1~3	3	Selects the CNG detection tone of friendly reception.
771	T1 timer	1:35 sec 2:60 sec	1, 2	1	Sets a higher value when the response from the other party needs more time during FAX transmission.
774	T4 timer	X 100 msec	00~99	00	Use this function when delay occurs in the line and communication (ex. Mobile comm) does not work well.
815	Sensor & Vox check				See <b>TEST FUNCTIONS (P.50)</b> .
844	Original setting	1:NORMAL 2:LIGHT 3:DARKER	1~3	1	Use this feature when you need to transmit and copy a document with very faint writing or very dark writing. NORMAL: Used for normal writing. LIGHT: Used for faint writing. DARKER: Used for dark writing. This feature will return to the normal mode after transmission or copying.
852	Print test pattern				See <b>TEST FUNCTIONS (P.50)</b> .
853	Top margin		1~9	5	-----
874	DTMFontime	060~200ms	060~200	090	-----
875	DTMFOfftime	060~200ms	060~200	085	-----
880	History list				See <b>HISTORY (P.58)</b> .
881	Journal 2 list				See <b>PRINTOUT EXAMPLE (P.95)</b> .
882	Journal 3 list				See <b>PRINTOUT EXAMPLE (P.95)</b> .

### 6.3. TEST FUNCTIONS

The codes listed below can be used to perform simple checks of some of the unit's functions. When complaints are received from customers, they provide an effective tool for identifying the locations and causes of malfunctions. To do this, you set the Service Mode (Refer to **OPERATION (P.47)**) first, then operate the below test items.

Test Mode	Type of Mode	Code	Function
		Operation after code input	
MOTOR TEST	Service Mode	"5" "5" "6"	Rotates the transmission and reception motor to check the operation of the motor. 12: Document feed 24: Recording paper is fed  Press <b>[STOP]</b> button to quit.
		START	
MODEM TEST	Service Mode	"5" "5" "4"	Telephone line circuit is connected automatically, output the following signals on the circuit line. 1) OFF 2) 9600bps 3)7200bps 4) 4800bps 5) 2400bps 6) 300bps 7) 2100Hz 8)1100Hz
		START	
ROM CHECK	Service Mode	"5" "5" "1" START	Indicates the version and checks the sum of the ROM.
SCAN CHECK	Service Mode	"5" "5" "5" START	Turns on the LEDs of the CIS and operates the read systems.
LCD CHECK	Service Mode	"5" "5" "8" START	Checks the LCD indication. Illuminates all the dots to check if they are normal.
DTMF SINGLE TEST	Service Mode	"5" "5" "2" 1...ON 2...OFF	Outputs the DTMF as single tones. Used to check the frequencies of the individual DTMF tones. Refer to <b>DTMF SINGLE TONE TRANSMIT SELECTION (P.51)</b> .
KEY CHECK	Service Mode	"5" "6" "1"	Checks the button operation. Indicates the button code on the LCD while the button is pressed. Refer to <b>BUTTON CODE TABLE (P.51)</b> .
		START (any key)	
MEMORY CLEAR	Service Mode	"5" "5" "0" START	To reset the value to the default one, except the top margin (#853), time/day (#001), logo (#002), Fax ID, History, Directory. Please restart a power supply after clearing a memory.
LED CHECK	Service Mode	"5" "5" "7" START	All LEDs above the operation panel board flash on and off, or are illuminated.
PRINT TEST PATTERN	Service Mode	"8" "5" "2"	Prints out the test pattern. Used mainly at the factory to test the print quality. You can select 1~4. (See <b>PRINT TEST PATTERN (P.52)</b> )
		START	
SENSOR CHECK & VOX CHECK	Service Mode	"8" "1" "5" START	If you enter this mode and operate sensor levers with your hands, the LCD display of the related sensor (or switch) turns ON / OFF. Also, when copying a document, the related sensor will turn ON / OFF. ( Do, Sn, Co, Pt, Vx) For each sensor's operation, refer to <b>SENSORS AND SWITCHES(P.135)</b> . <b>Do Sn Co Pt Vx</b> : LCD DISPLAY <b>Do: Document set sensor</b> :Paper inserted. Turns on when a document is inserted. <b>Sn: Read position sensor.</b> :At the read position, turns on when the front cover is opened and the sensor lever is pressed directory. <b>Co: Cover open sensor / Film end sensor</b> :Cover open of don't set the film. Turns on and off when the front cover is opened and closed. <b>Pt: Paper top sensor</b> :Sensor on Turns on when the front cover is opened and the sensor lever is pressed directly. <b>Vx: Vox signal</b> :Detection signal for the tone on the line. Turns on when there is a tone signal on the line.

**Note:**

The numbers in the boxes (XXX) indicate the keys to be input for the various test modes.

### 6.3.1. DTMF SINGLE TONE TRANSMIT SELECTION

When set to ON (=1), the 12 keys and transmission frequencies are as shown.

key	High Frequency (Hz)	key	Low Frequency (Hz)
"1"	697	"5"	1209
"2"	770	"6"	1336
"3"	852	"7"	1477
"4"	941	"8"	1633

When set to OFF (=2), the 12 keys and transmission frequencies are as shown.

High (Hz)	1209	1336	1477
Low (Hz)			
697	"1"	"2"	"3"
770	"4"	"5"	"6"
852	"7"	"8"	"9"
941	" <del>X</del> "	"0"	"#"

**Note:**

After performing this check, do not forget to turn the setting off.

Otherwise, dialing in DTMF signal will not work.

### 6.3.2. BUTTON CODE TABLE

Code	Button Name	Code	Button Name	Code	Button Name	Code	Button Name
04	FAX /START / SET	31	1	3C	#	64	STATION 1
05	LOWER	32	2	3D	REDIAL PAUSE	65	STATION 2
06	COPY	33	3	3E	FLASH	66	STATION 3
08	MONITOR	34	4	47	SEARCH	67	STATION 4
0A	MUTE	35	5	4E	JUNK FAX PROHIBITOR	68	STATION 5
0C	RECEIVE MODE	36	6	1E	▶ NEXT		
20	MENU	37	7	1F	◀ PREV		
22	HELP	38	8				
25	[+] VOLUME	39	9	00	NO INPUT		
26	[-] VOLUME	3A	0	01	STOP		
		3B	<del>X</del>				

### 6.3.3. PRINT TEST PATTERN

#### 1. Platen roller

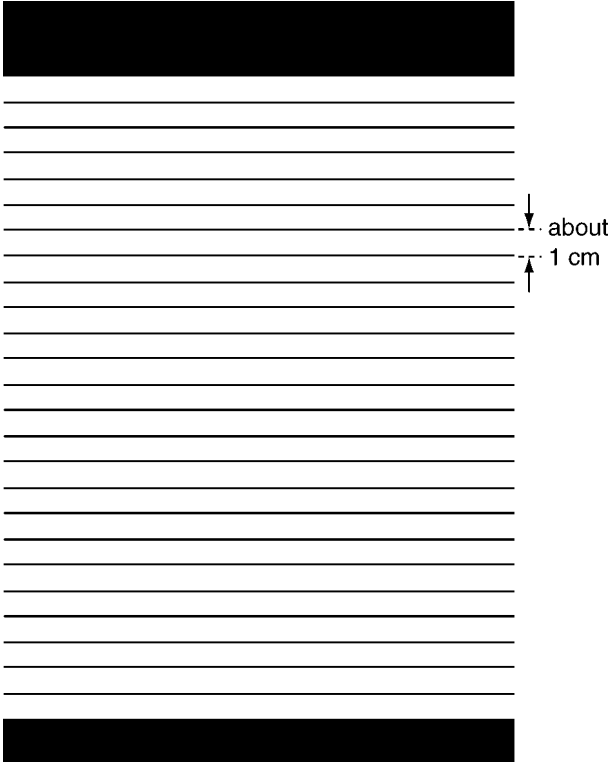

#### 3. Thermal head 1 dot

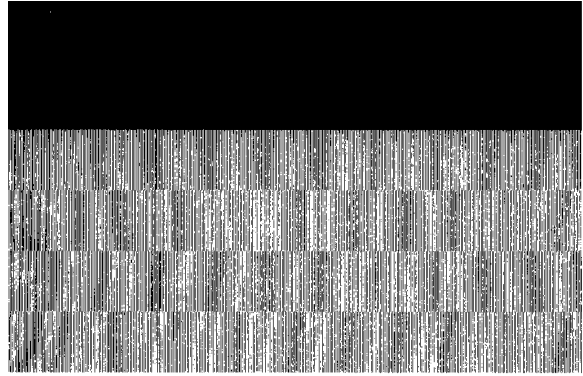

#### 2. Left margin / Top margin

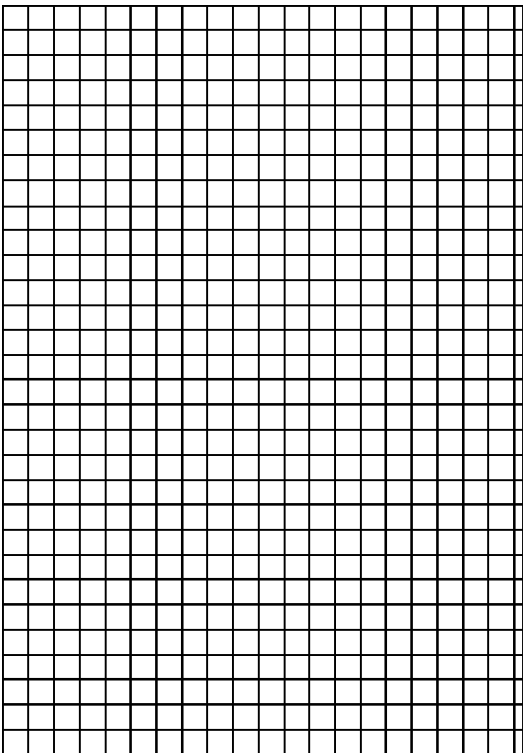

#### 4. Use this test pattern to confirm the torque limiter for ink film and platen roller timing

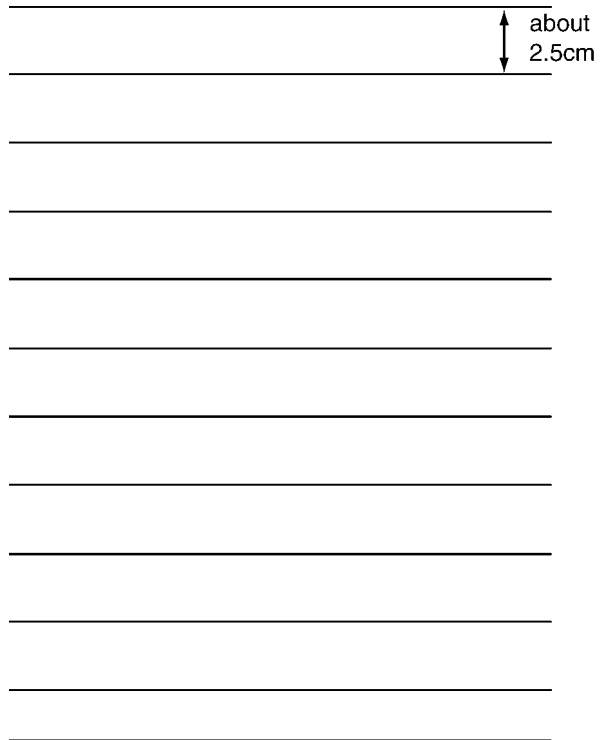

## 6.4. REMOTE PROGRAMMING

If, after the call is connected, the customer describes the situation and it is determined that the problem can be corrected by making parameter changes, this function makes it possible to change parameters such as the user code and service code from another fax (using DTMF tones). Therefore, travel to the customer's location is not required. However, it is not possible to change all the parameters remotely (**PROGRAM MODE TABLE (P.54)**). The function used to accomplish this is remote programming.

First, in order to check the current status of the service code parameter, print out the setup list (code: 991) and the service list (code: 999) from the customer's fax machine.

Based on this, the parameters for the desired codes can be changed.

The procedure for changing and listing parameters is described on **ENTERING THE REMOTE PROGRAMMING MODE AND CHANGING SERVICE CODES (P.53)**. Also, before exiting the remote programming mode, it is advisable to obtain a new list to confirm that the changes were made correctly.

### Hint:

Since the connected telephone is in use during the remote programming mode, it may be helpful to ask the customer to switch to the speakerphone. This frees the customer from the need to remain right next to the fax while you are making parameter settings. When finished, inform the customer. Also note that in very noisy locations where the DTMF tones are not audible, the remote programming function will not work.

### 6.4.1. ENTERING THE REMOTE PROGRAMMING MODE AND CHANGING SERVICE CODES

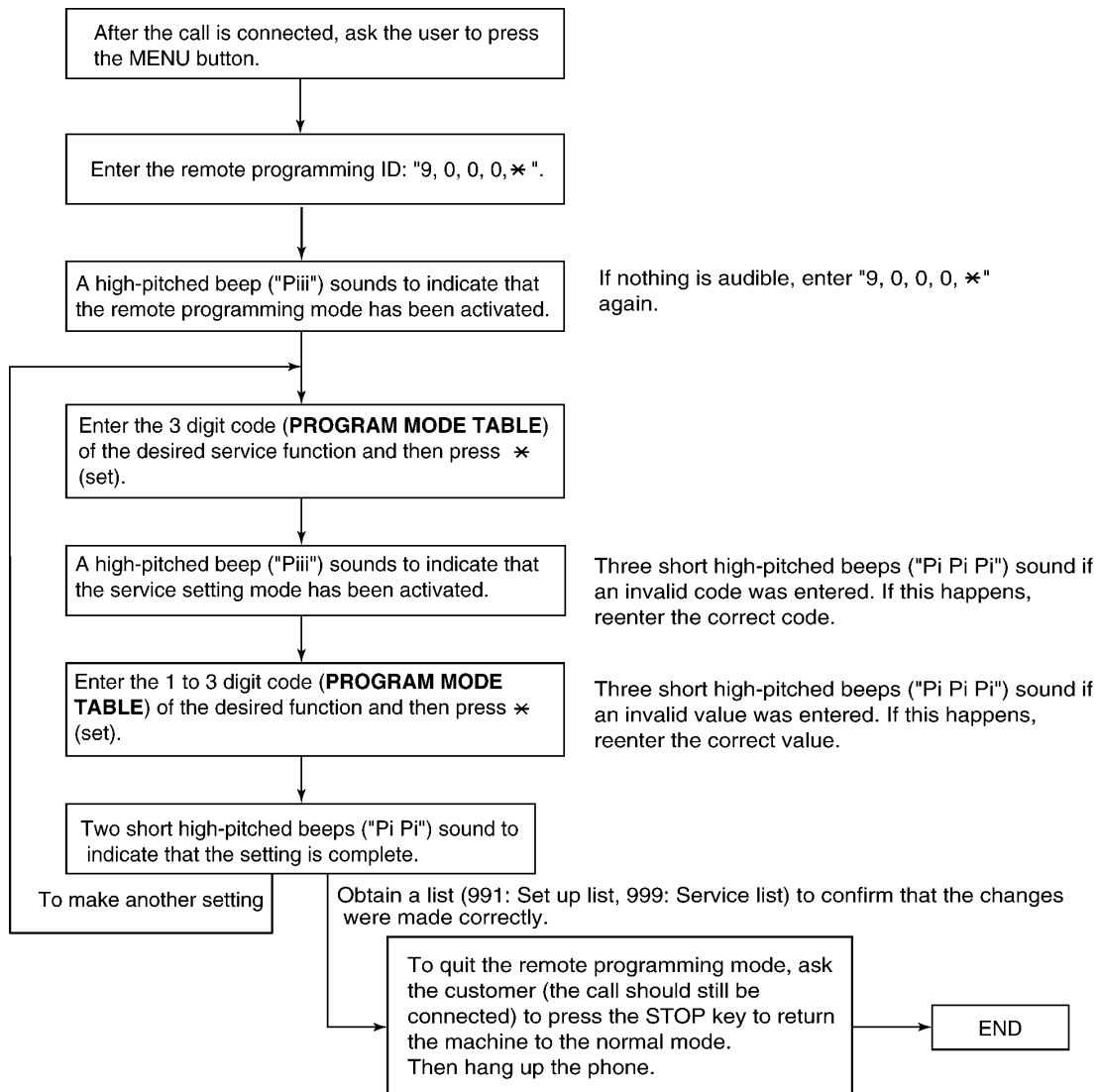

### CROSS REFERENCE:

**PROGRAM MODE TABLE (P.54)**

## 6.4.2. PROGRAM MODE TABLE

Code	Function	Set Value	Default	Remote Setting
001	Set date and time	mm/dd/yy hh:mm	Jan/01/2003	NG
002	Your logo	-----	None	NG
003	Your FAX number	-----	None	NG
004	Print sending mode	1:ERROR/ 2:ON / 3:OFF	ERROR	OK
006	FAX ring count	1 to 5 rings (for ext. tam)	2	OK
012	Remote TAM activation	ON / OFF	OFF / ID=11	NG
013	Dialling mode	1:TONE / 2: PULSE	TONE	OK
016	Paper size	1:A4 / 2:LETTER	A4	OK
017	Ringer Pattern	A / B / C	A	NG
022	Journal auto print	1:ON / 2:OFF	ON	OK
023	Overseas mode	1:ON / 2:OFF	OFF	OK
025	Delayed transmission	1:ON / 2:OFF	OFF	NG
026	Auto caller ID list	1:ON / 2:OFF	ON	OK
031	Distinctive Ring	1:OFF / 2:ON	OFF	OK
032	Fax ring pattern	1:B-D / 2:A / 3:B / 4:C / 5:D	B-D	OK
034	Quick scan	1:ON / 2:OFF	OFF	OK
036	RCV reduction	1:92% / 2:86% / 3:72% / 4:100%	92%	OK
039	LCD contrast	NORMAL / DARKER	NORMAL	NG
040	Silent detection	1:ON / 2:OFF	OFF	OK
041	FAX activation code	ON / OFF	ON ID=#9	NG
044	Memory receive alert	1:ON / 2:OFF	ON	OK
046	Friendly receive	1:ON / 2:OFF	ON	OK
058	Original setting	1:NORMAL / 2:LIGHT / 3:DARKER	NORMAL	OK
068	ECM selection	1:ON / 2:OFF	ON	OK
076	Connecting tone	1:ON / 2:OFF	ON	OK
080	Set default	1:YES / 2:NO	NO	NG
501	Pause time set	001~600 x 100msec	030msec	OK
502	Flash time	01~99 x 10ms	70ms	OK
503	Dial speed	1:10pps / 2:20 pps	10pps	OK
511	Vox sense	1:High / 2:Low	High	OK
514	Bell detection time	1~9x100msec	6sec	OK
520	CED frequency select	1:2100Hz / 2:1100Hz	2100Hz	OK
521	International mode select	1:ON / 2:OFF	ON	OK
522	Auto standby select	1:ON / 2:OFF	ON	OK
523	Receive equalizer select	1:0km / 2:1.8km / 3:3.6km / 4:7.2km	0km	OK
524	Transmission equalizer select	1:0km / 2:1.8km / 3:3.6km / 4:7.2km	0km	OK
550	Memory clear	-----	-----	NG
551	ROM check	-----	-----	NG
552	DTMF signal tone test	1:ON / 2:OFF	OFF	OK
553	Monitor on FAX communication	1:OFF / 2:Phase B / 3:ALL	OFF	OK
554	Modem test	-----	-----	NG
555	Scanner test	-----	-----	NG
556	Motor test	-----	-----	NG
558	LCD test	-----	-----	NG
559	Document jam detection	1:ON / 2:OFF	ON	OK
561	Key test	-----	-----	NG
570	Break % select	1:61% / 2:67%	61%	OK
571	ITS auto redial time set	00~99	05	OK
572	ITS auto redial line disconnection time set	001~999sec	065sec	OK
573	Remote turn-on ring number	01~99	10	OK
590	FAX auto redial time set	00~99	05	OK
591	FAX auto redial line disconnection time set	001~999sec	065sec	OK
592	CNG transmit select	1:OFF / 2:ALL / 3:AUTO	ALL	OK
593	Time between CED and 300 bps	1:75ms / 2:500ms / 3:1sec	75ms	OK
594	Overseas DIS detection	1:1st / 2:2nd	1st	OK
595	Receive error limit value	001~999	100	OK
596	Transmit level set	-15~00dBm	-10dBm	OK
598	Receiving Sensitivity	20~48	40	OK
700	EXT. TAM OGM Rec. time	01~99sec	10sec	OK
701	No voice detect time	01~99 x 100msec	50	OK
717	Transmit speed select	1:9600/ 2:7200/ 3:4800/ 4:2400	9600bps	OK
718	Receive speed select	1:9600/ 2:7200/ 3:4800/ 4:2400	9600bps	OK
722	Redial tone detect	1:ON / 2:OFF	ON	OK
745	Power on film feed	1:ON / 2:OFF	ON	OK

Code	Function	Set Value	Default	Remote Setting
763	CNG detect time for friendly reception	1:10s / 2:20s / 3:30s	30s	OK
771	T1 timer	1:35s / 2:60s	35s	OK
774	T4 timer	00~99 × 100ms	00ms	OK
815	Sensor & VOX test	-----	-----	NG
844	Original setting	1:Normal / 2:Light / 3:Darker	Normal	NG
852	Print test pattern	-----	-----	NG
853	Top margin	1~9	5	OK
874	DTMF ON time	060~200ms	090ms	OK
875	DTMF OFF time	060~200ms	085ms	OK
880	History list	1:Start	-----	NG
881	Journal 2	-----	-----	NG
882	Journal 3	-----	-----	NG
991	Setup list	1:Start	-----	OK
994	Journal list	1:Start	-----	OK
995	Journal 2 list	1:Start	-----	OK
996	Journal 3 list	1:Start	-----	OK
998	History list	1:Start	-----	OK
999	Service list	1:Start	-----	OK

OK means "can set".

NG means "can not set".

**Note:**

Refer to **SERVICE FUNCTION TABLE** (P.48) for descriptions of the individual codes.

**Example:**

If you want to set value in the "004 Transmission report mode", press the dial key number 1,2 or 3 corresponding to the Set Value you want to select. (1:ERROR/2:ON/3:OFF)

## 6.5. THE EXAMPLE OF THE PRINTED LIST

### 6.5.1. USER MODE

#### STEUP LIST

##### [ BASIC FEATURE LIST ]

NO.	FEATURE	CURRENT SETTING
Code → #01	SET DATE & TIME	Jan. 01 2003 12:00AM
#02	YOUR LOGO	
#03	YOUR FAX NUMBER	
#04	PRINT SENDING REPORT	ERROR [ERROR, ON, OFF]
#06	FAX RING COUNT	2 [1...5] *5 FOR EXTERNAL TAM
#12	REMOTE TAM ACTIVATION	OFF [ON, OFF]
		ID = 11
#13	DIALLING MODE	tone [TONE, PULSE]
#16	PAPER SIZE	A4 [A4, LETTER]
#17	RINGER PATTERN	A [A, B, C]

↙ Set Value

##### [ ADVANCED FEATURE LIST ]

NO.	FEATURE	CURRENT SETTING
Code → #22	JOURNAL AUTO PRINT	ON [ON, OFF]
#23	OVERSEAS MODE	OFF [ON, OFF]
Code → #25	DELAYED TRANSMISSION	OFF [ON, OFF]
		DESTINATION =
		START TIME = 12:00AM
#26	AUTO CALLER ID LIST	ON [ON, OFF]
#31	DISTINCTIVE RING	OFF [ON, OFF]
#32	FAX RING PATTERN	B-D [B-D, A, B, C, D]
#34	QUICK SCAN	OFF [ON, OFF]
#36	RCU REDUCTION	92% [72, 86, 92, 100]
#39	LCD CONTRAST	NORMAL [NORMAL, DARKER]
#40	SILENT DETECTION	OFF [ON, OFF]
#41	FAX ACTIVATION CODE	ON [ON, OFF]
		CODE = *#9
#44	MEMORY RECEIVE ALERT	ON [ON, OFF]
#46	FRIENDLY RECEPTION	ON [ON, OFF]
#58	ORIGINAL SETTING	NORMAL [NORMAL, LIGHT, DARKER]
#68	ECM SELECTION	ON [ON, OFF]
<b>NOTE : You cannot change the setting of this feature, if there are stored documents in memory.</b>		
#76	CONNECTING TONE	ON [ON, OFF]
#80	SET DEFAULT (EXCEPT #68)	↙ Set Value

**Note:**

The above values are the default values.



### 6.5.2. SREVICE MODE SETTINGS

【 SERVICE DATA LIST 】		
		Set Value
Code →	501 PAUSE TIME	= 030*100ms [001...600]*100ms
	502 FLASH TIME	= 70*10ms [01...99]*10ms
	503 DIAL SPEED	= 10pps [1=10 2=20]pps
	520 CED FREQ.	= 2100Hz [1=2100 2=1100]Hz
	521 INTL. MODE	= ON [1=ON 2=OFF]
	522 AUTO STANDBY	= ON [1=ON 2=OFF]
	523 RX EQL.	= 0.0Km [1=0.0 2=1.8 3=3.6 4=7.2]Km
	524 TX EQL.	= 0.0Km [1=0.0 2=1.8 3=3.6 4=7.2]Km
	700 EXT.TAM OGM REC. TIME	= 10sec [01...99]sec
	701 NO VOICE DETECT TIME	= 50*100msec [01...99]*100msec
	853 TOP MARGIN	= 5 [1...9]

【 SPECIAL SERVICE SETTINGS 】													
Code →	511	514	552	553	559	570	571	572	573	590	591	592	593
	1	6	2	1	1	1	05	065	10	05	065	2	1
	Set Value												
	594	595	596	598	599	717	718	722	745	763	771	774	874
	1	100	10	40	1	1	1	1	1	3	1	00	090
	875												
	085												

USAGE TIME = 00000 HOURS

**Note:**

The above values are the default values.

### 6.5.3. HISTORY

[ HISTORY ]

[ U e r 0 . 4 ] (1)      [ 9 A 6 9 ] (2)  
 [ N O N E ] (3)  
 [ N O N E ] (4)  
 [ N O N E ] (5)  
 (6) [ 0 0 0 0 ] [ 0 1 ] (7) [ 0 1 ] (8) [ 2 0 0 1 ] (9)      [ 0 0 0 0 ] (10)  
 (11) [ 0 0 0 0 ] [ 0 0 0 0 ] (12)  
 (13) [ 0 0 0 0 ] [ 0 0 0 0 ] (14) [ N O N E ] (15) [ N O N E ] (16)      [ F A X ] (17)  
 Factory use only [ 0 0 0 0 ] [ 0 0 0 0 ] [ T O N E ] (18) [ 9 2 % ] (19)      [ 0 0 0 0 1 ] (20)  
 (21) [ 0 0 0 0 ] [ 0 0 0 0 ] (22) [ 0 0 0 0 ] (23) [ 0 0 0 0 ] (24)      [ N O N E ] (25)  
 (26) [ N O N E ] [ N O N E ] (27) [ N O N E ] (28) [ N O N E ] (29)  
 (30) [ 0 0 0 ] (31) [ 0 0 0 ] (32) [ 0 0 0 0 ] [ N O N E ] (33)  
 (34) [ 0 0 0 0 ] [ 0 0 0 0 ] (35) [ 0 0 0 0 ] (36) [ 0 0 0 0 ] (37)      (38) [ 0 0 0 0 ] [ 0 0 0 0 ] (39)  
 (40) [ 0 0 0 0 ] [ 0 0 0 0 ] (41) [ 0 0 0 0 ] (42) [ 0 0 0 0 ] (43)      [ 0 0 0 0 ] (44)

NAME \_\_\_\_\_ DATE \_\_\_\_\_ DEALER \_\_\_\_\_ FILM \_\_\_\_\_

CUSTOMER COMPLAINT

SURVEY RESULT : CKOK (UNKNOWN/DESIGN/EDUC) DEFECT (PART/WORKER/DESIGN)  
 ABUSE (CUST/DEALER/SHIP) NEW (OPEN/NOT)  
 PHONE SURVEY RESULT.

**Note:**  
 See the following descriptions of this report. Item No. (1) ~ (44) are corresponding to the listed items in **DESCRIPTIONS OF THE HISTORY REPORT** (P.59).

### 6.5.3.1. DESCRIPTIONS OF THE HISTORY REPORT

(1) ROM VERSION FLASH ROM version	The number of pages received.
(2) SUM FLASH ROM internal data calculation.	(23) NUMBER OF SENDING The number of pages sent.
(3) YOUR LOGO The user logo recorded in the unit. If it is not recorded, NONE will be displayed.	(24) NUMBER OF CALLER ID The number of times Caller ID was received.
(4) YOUR TELEPHONE NUMBER The user telephone number recorded in the unit. If it is not recorded, NONE will be displayed.	(25) NUMBER OF RECORDING MESSAGE The number of messages recorded in TAM.
(5) FAX PAGER NUMBER If you program a pager number into the unit, the pager number will be displayed here.	(26)~(29) Not Used
(6) FACTORY - CUSTOMER This shows how many days from factory production until the user turns ON the unit.	(30) NUMBER OF PRINTING WARNING LIST The number of warning lists printed until now.
(7) MONTH The shows the very first month, date, year and time set by the user after they purchased the unit.	(31) NUMBER OF PRINTING HELP The number of help lists printed until now.
(8) DAY The shows the very first month, date, year and time set by the user after they purchased the unit.	(32) NUMBER OF DIVIDED PRINTING IN FAX RECEPTION The number of faxes received that were divided into more than one sheet since the unit was purchased.
(9) YEAR The shows the very first month, date, year and time set by the user after they purchased the unit.	(33) Not Used
(10) TIME The shows the very first month, date, year and time set by the user after they purchased the unit.	(34) FAX MODE Means the unit received a fax message in the FAX mode.
(11) USAGE TIME The amount of time the unit has been powered ON.	(35) MAN RCV Means the unit received a fax message by manual operation.
(12) FACTORY - NOW This shows how many days from factory production until the user prints out this history list.	(36) FRN RCV Means the unit received a fax message by friendly signal detection.
(13) TEL MODE The amount of time the TEL mode setting was used.	(37) VOX Means the unit detected silence or no voice.
(14) FAX MODE The amount of time the FAX mode setting was used.	(38) RMT DTMF Means the unit detected DTMF (Remote Fax activation code) entered remotely.
(15) Not Used	(39) PAL DTMF Means the unit detected DTMF (Remote Fax activation code) entered by a parallel connected telephone.
(16) ANS/FAX MODE The amount of time the ANS/FAX mode setting was used.	(40) TURN-ON Means the unit started to receive after 10 rings. (Remote Turn On: Service Code #573)
(17) FINAL RECEIVE MODE The last set receiving mode by the user.	(41) TIME OUT Means the unit started to receive after Ring Time Out in the EXT-TAM or TEL/FAX mode.
(18) TONE/PULSE SELECTION The most recently used setting used, either TONE or PULSE.	(42) IDENT Means the unit detected Ring Detection.
(19) RECEIVE REDUCTION The compression rate when receiving.	(43) CNG OGM Means the unit detected the CNG while it was sending the Dummy Ring Back Tone in the TEL/FAX mode, or while answering a call in the EXT-TAM mode. Or means the unit detected the CNG while it was sending the OGM in the ANS/FAX mode.
(20) SETTING NO. OF DIRECTORY The recorded directory stations.	(44) CNG ICM Means the unit detected the CNG while it was recording the ICM in the ANS/FAX mode.
(21) NUMBER OF COPY The number of pages copied.	
(22) NUMBER OF RECEIVE	

## 6.6. TROUBLESHOOTING DETAILS

### 6.6.1. OUTLINE

Troubleshooting is for recovering quality and reliability by determining the broken component and replacing, adjusting or cleaning it as required. First, determine the problem then decide the troubleshooting method. If you have difficulty finding the broken part, determine which board is broken. (For example: the Digital PCB, Analog PCB, etc.) The claim tag from a customer or dealer may use different expressions for the same problem, as they are not a technician or engineer. Using your experience, test the problem area corresponding to the claim. Also, returns from a customer or dealer often have a claim tag. For these cases as well, you need to determine the problem. Test the unit using the simple check list on **SIMPLE CHECK LIST**(P.61). Difficult problems may be hard to determine, so repeated testing is necessary.

### 6.6.2. STARTING TROUBLESHOOTING

Determine the symptom and the troubleshooting method.

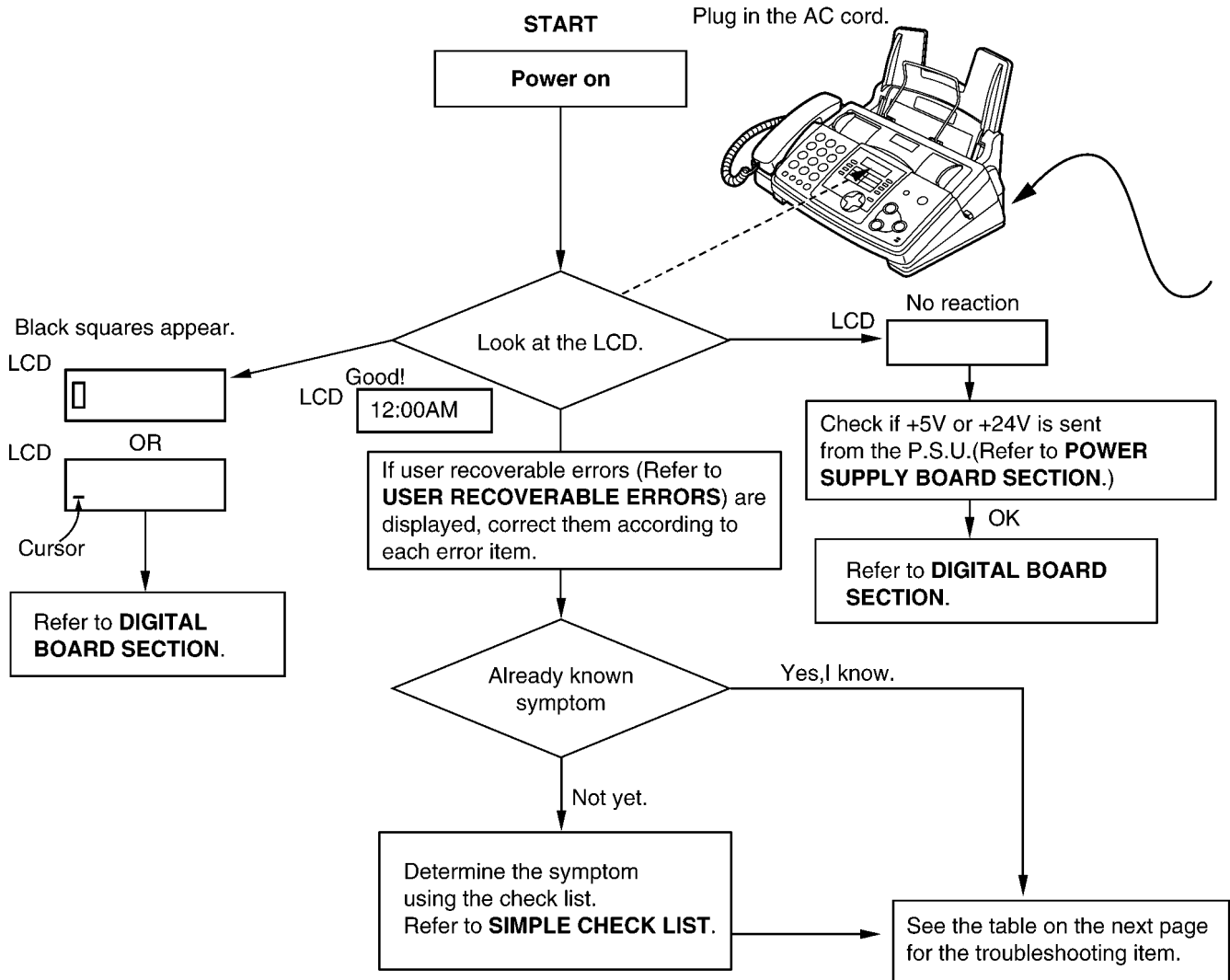

**CROSS REFERENCE:**

- USER RECOVERABLE ERRORS** (P.45)
- SIMPLE CHECK LIST** (P.61)
- DIGITAL BOARD SECTION** (P.97)
- POWER SUPPLY BOARD SECTION** (P.108)

### 6.6.3. TROUBLESHOOTING ITEMS TABLE

ITEM	SYMPTOM	REFERENCE
ADF (Auto Document Feeder)	The document does not feed.	<b>NO DOCUMENT FEED</b> (P.62)
	Document jam	<b>DOCUMENT JAM</b> (P.63)
	Multiple feed	<b>MULTIPLE FEED</b> (P.64)
	Skew	<b>SKEW</b> (P.65)
Recording paper feed	The recording paper does not feed.	<b>THE RECORDING PAPER DOES NOT FEED</b> (P.66)
	Paper jam	<b>PAPER JAM</b> (P.67)
	Multiple feed and skew	<b>MULTIPLE FEED AND SKEW</b> (P.68)
Printing	The sent fax data is skewed.	<b>THE SENT FAX DATA IS SKEWED</b> (P.68)
	The received fax data is skewed.	<b>THE RECEIVED FAX DATA IS SKEWED</b> (P.68)
	The received or copied data is expanded.	<b>RECEIVED OR COPIED DATA IS EXPANDED</b> (P.69)
	A blank page is copied.	<b>A BLANK PAGE IS COPIED</b> (P.62)
	A blank page is received.	<b>A BLANK PAGE IS RECEIVED</b> (P.72)
	Black or white vertical line	<b>BLACK OR WHITE VERTICAL LINE</b> (P.72)
	Black or white lateral line	<b>BLACK OR WHITE LATERAL LINE ON PRINT OUT</b> (P.73)
Communication FAX, TEL (analog board)	Cannot communicate by fax. An error code is displayed.	See <b>COMMUNICATION SECTION</b> (P.75)
	Cannot talk. The DTMF tone doesn't work. The handset / monitor doesn't work, etc.	See <b>ANALOG BOARD SECTION</b> (P.105)
Operation panel	Keys are not accepted.	See <b>OPERATION PANEL SECTION</b> (P.111)
Sensor	If the electric circuit is the cause, the error message corresponding to the sensor will be displayed.	See <b>SENSOR SECTION</b> (P.112)

#### 6.6.3.1. SIMPLE CHECK LIST

SERIAL NO.		DATE	
FUNCTION	JUDGEMENT	REFERENCE	
FAX operation	Transmission	OK / NG	
	Receiving	OK / NG	
Copy operation		OK / NG	
Telephone operation	Handset transceiver / receiver	OK / NG	
	MONITOR sound	OK / NG	
	Ringer sound	OK / NG	
	Dial operation	OK / NG	
	Volume operation	OK / NG	
	VOX detection	OK / NG	Service code #815 (Refer to <b>TEST FUNCTIONS</b> (P.50))
Operation Panel	Key check	OK / NG	Service code #561 (Refer to <b>TEST FUNCTIONS</b> (P.50))
	LED check	OK / NG	Service code #557 (Refer to <b>TEST FUNCTIONS</b> (P.50))
	LCD check	OK / NG	Service code #558 (Refer to <b>TEST FUNCTIONS</b> (P.50))
Sensor	Sensor check	OK / NG	Service code #815 (Refer to <b>TEST FUNCTIONS</b> (P.50))
Clock	Display changing	OK / NG	Is the time kept correctly? Check with another clock.
Ext-TAM	Handset transceiver / receiver	OK / NG	
	Remote control	OK / NG	

## 6.6.4. ADF (Auto Document Feed) SECTION

### 6.6.4.1. NO DOCUMENT FEED

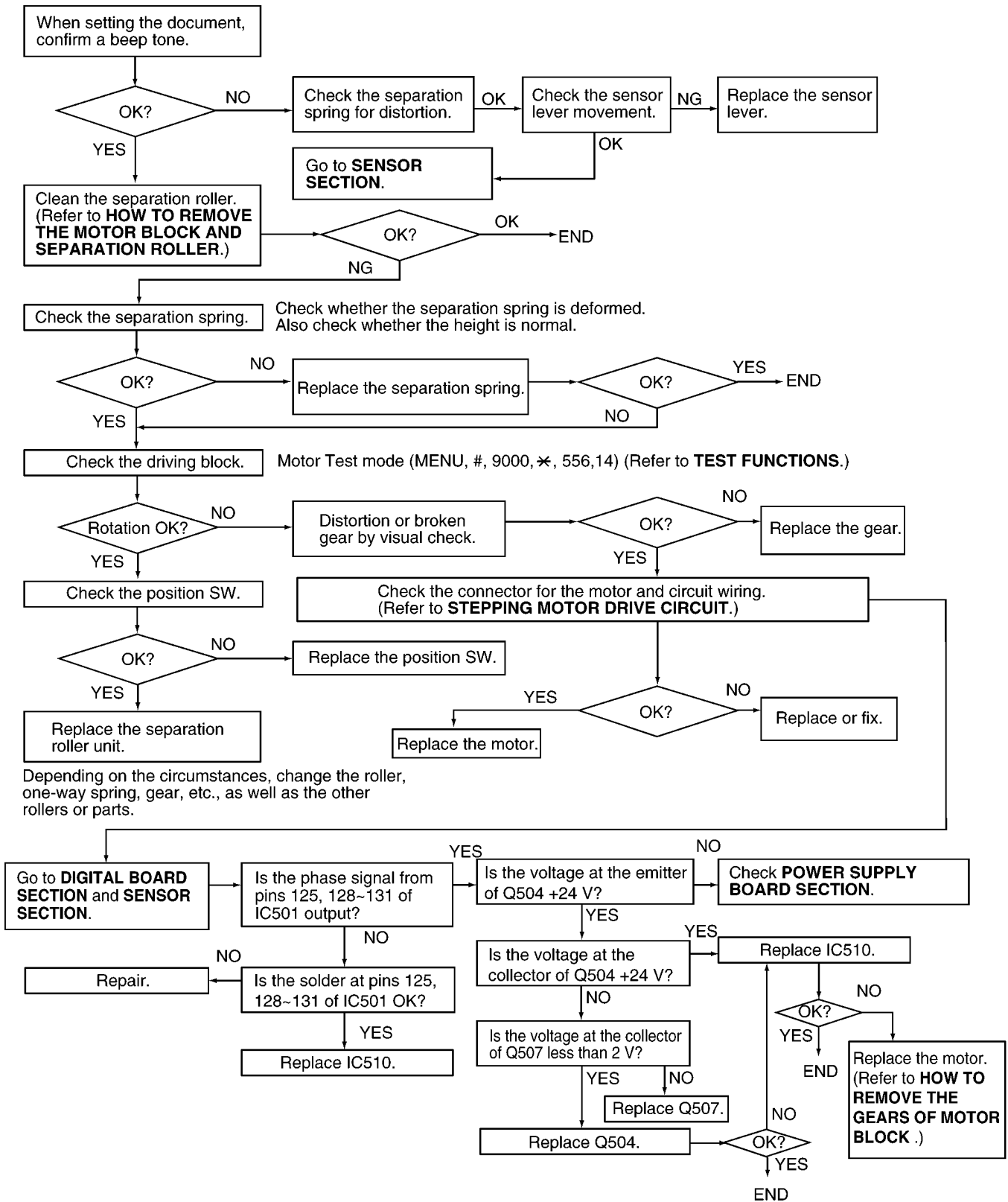

**CROSS REFERENCE:**

- TEST FUNCTIONS** (P.50)
- DIGITAL BOARD SECTION** (P.97)
- POWER SUPPLY BOARD SECTION** (P.108)
- SENSOR SECTION** (P.112)
- STEPPING MOTOR DRIVE CIRCUIT (TX)** (P.133)

**HOW TO REMOVE THE MOTOR BLOCK AND SEPARATION ROLLER** (P.42)

**HOW TO REMOVE THE GEARS OF MOTOR BLOCK** (P.43)

### 6.6.4.2. DOCUMENT JAM

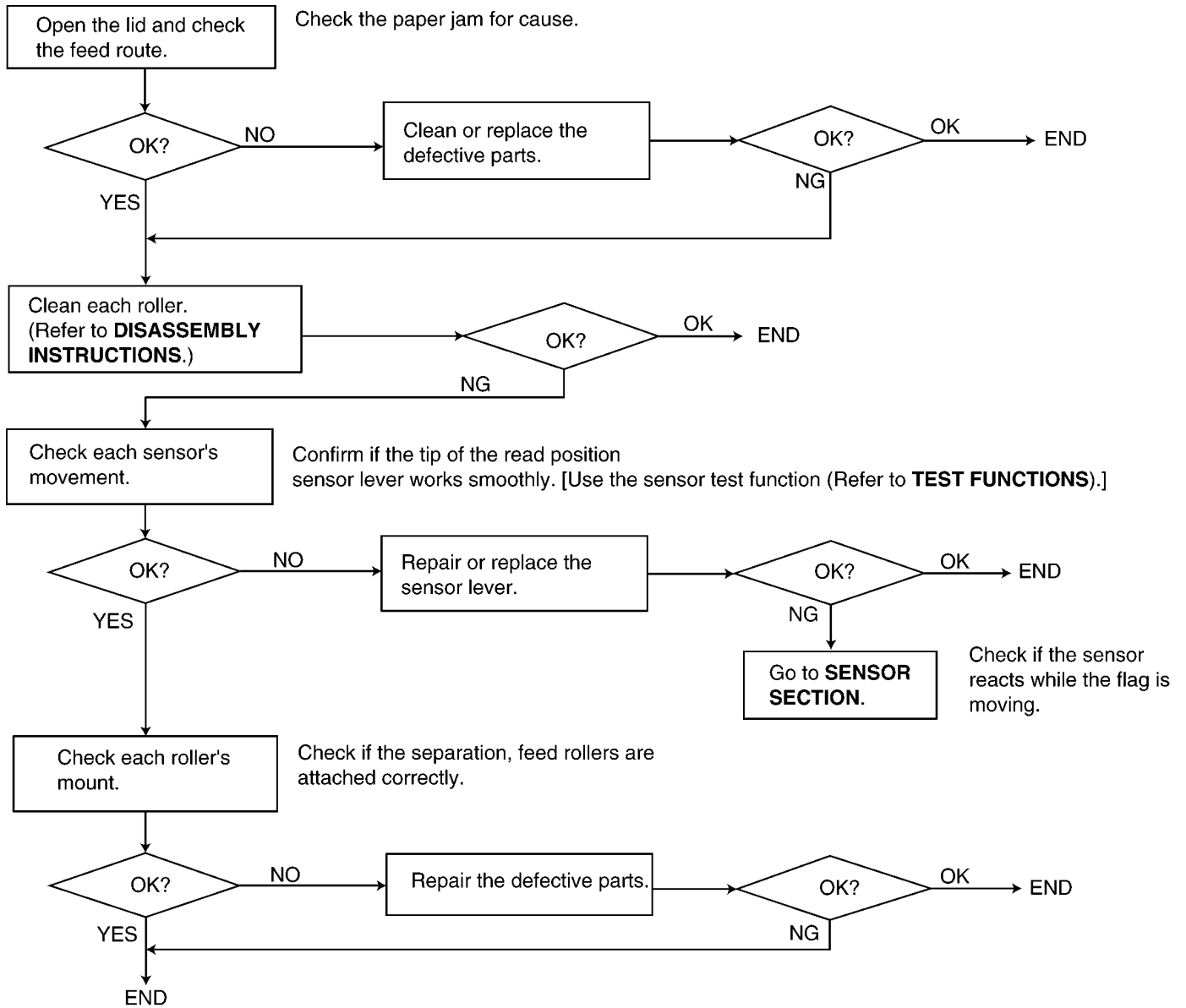

**CROSS REFERENCE:**

**TEST FUNCTIONS** (P.50)

**SENSOR SECTION** (P.112)

**DISASSEMBLY INSTRUCTIONS** (P.30)

### 6.6.4.3. MULTIPLE FEED

· When using thick paper etc., sometimes the document will not be fed.

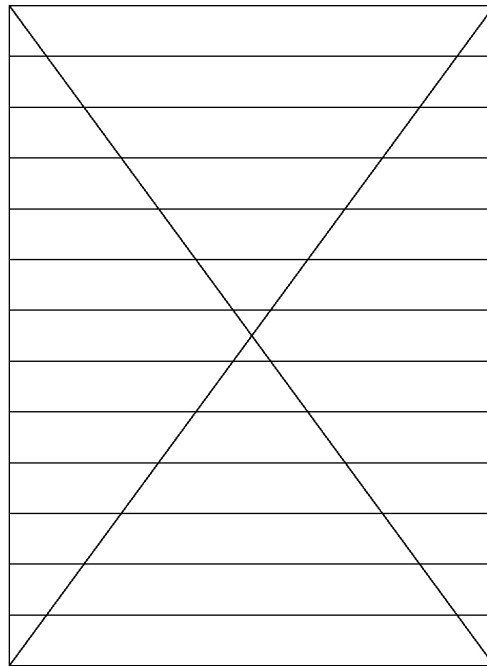
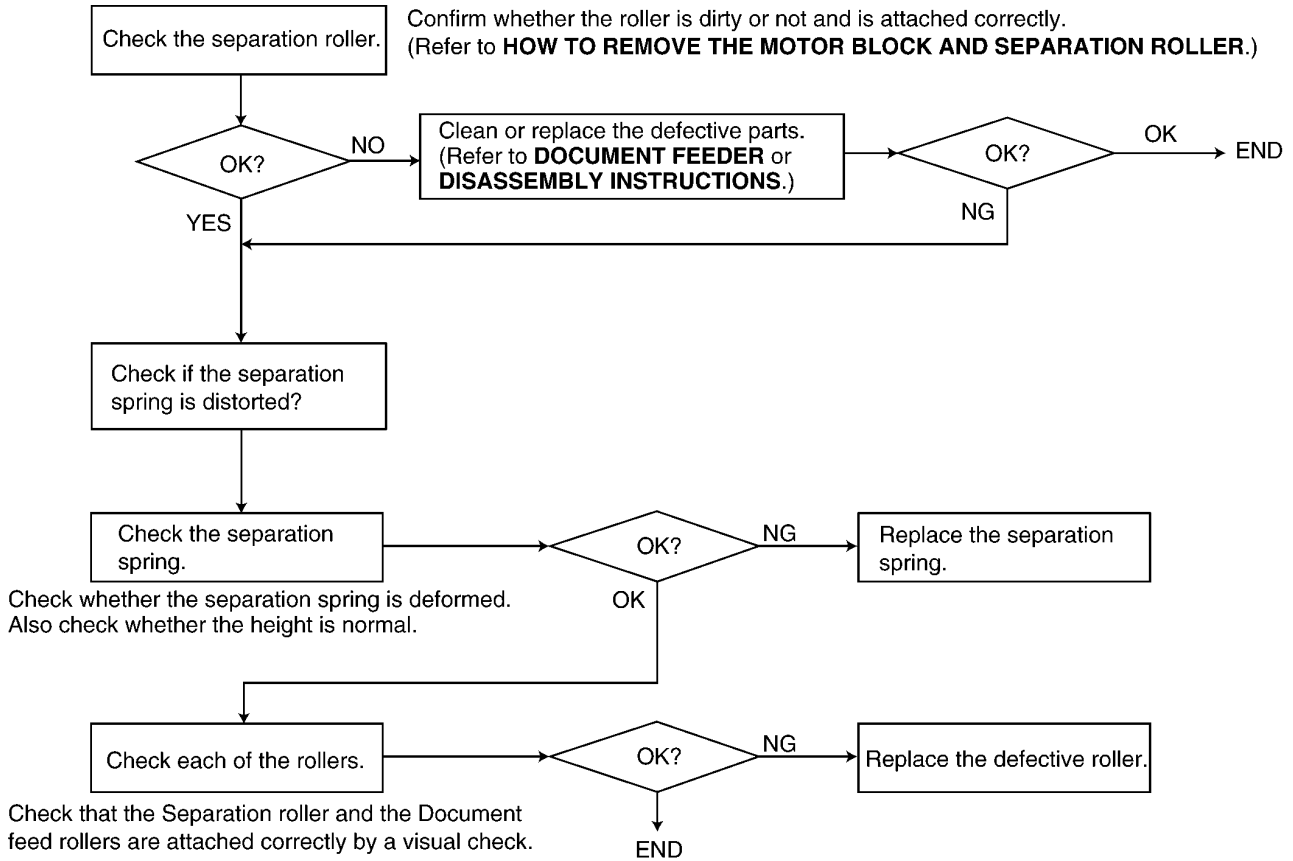

Fig. B

**CROSS REFERENCE:**

**DOCUMENT FEEDER (P.27)**

**DISASSEMBLY INSTRUCTIONS (P.30)**

**HOW TO REMOVE THE MOTOR BLOCK AND SEPARATION ROLLER (P.42)**

**Note:**

When confirming if the characters are extended or distorted, or if the feed problem is occurred, use this test chart format (Fig. B).



### 6.6.4.4. SKEW

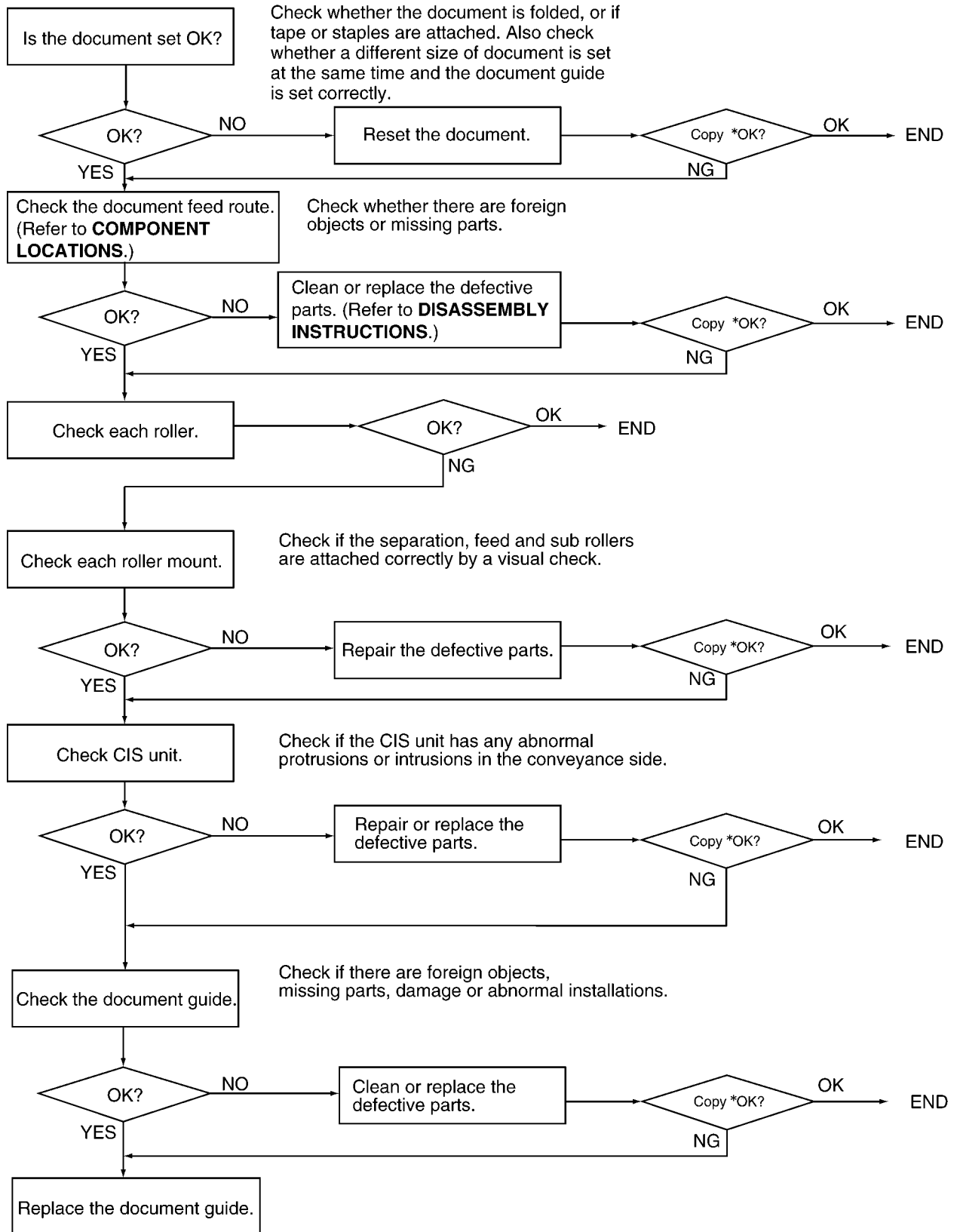

\* We recommend making a copy of the Fig. B document in **MULTIPLE FEED** (P.64) and using it.

**CROSS REFERENCE:**

**COMPONENT LOCATIONS** (P.21)

**DISASSEMBLY INSTRUCTIONS** (P.30)

### 6.6.4.5. THE RECORDING PAPER DOES NOT FEED

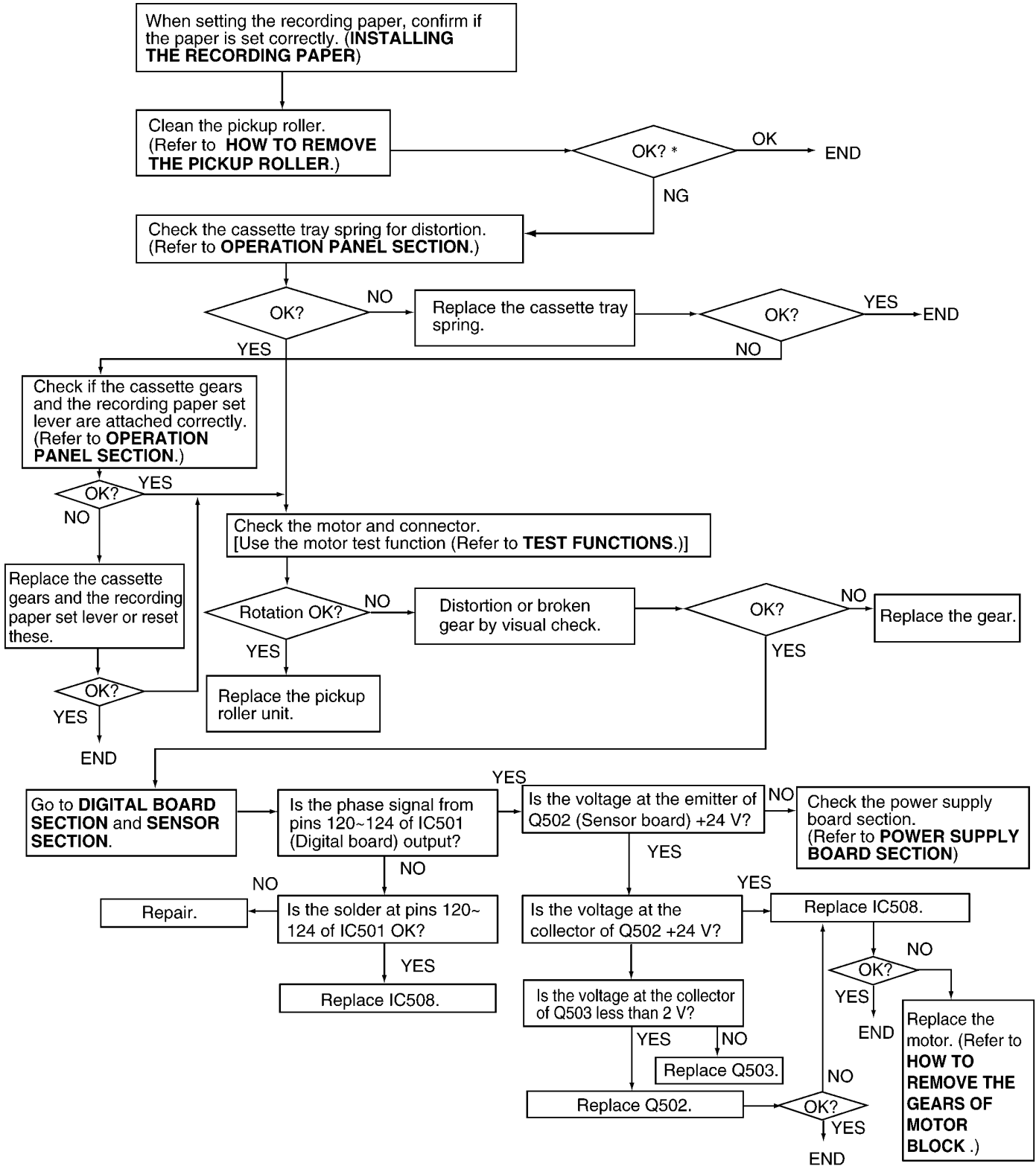

\* We recommend making a copy of the Fig. B document in **MULTIPLE FEED** (P.64) and using it.

**CROSS REFERENCE:**

- INSTALLING THE RECORDING PAPER (P.16)
- TEST FUNCTIONS (P.50)
- HOW TO REMOVE THE PICKUP ROLLER (P.38)
- HOW TO REMOVE THE GEARS OF MOTOR BLOCK (P.43)
- DIGITAL BOARD SECTION (P.97)

- POWER SUPPLY BOARD SECTION (P.108)
- SENSOR SECTION (P.112)
- OPERATION PANEL SECTION (P.166)

### 6.6.4.6. PAPER JAM

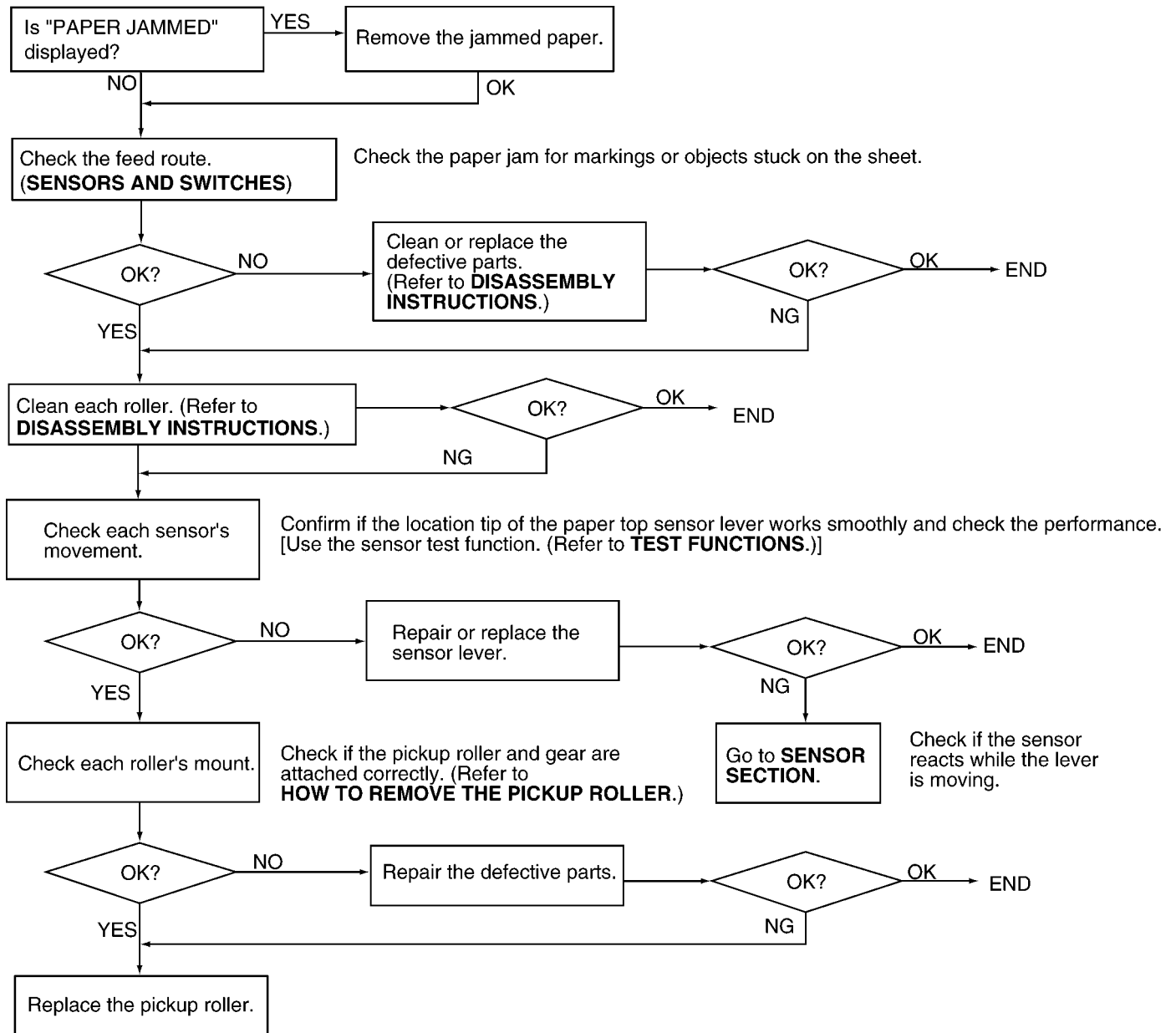

**CROSS REFERENCE:**

- DISASSEMBLY INSTRUCTIONS** (P.30)
- HOW TO REMOVE THE PICKUP ROLLER** (P.38)
- TEST FUNCTIONS** (P.50)
- SENSOR SECTION** (P.112)
- SENSORS AND SWITCHES** (P.135)

### 6.6.4.7. MULTIPLE FEED AND SKEW

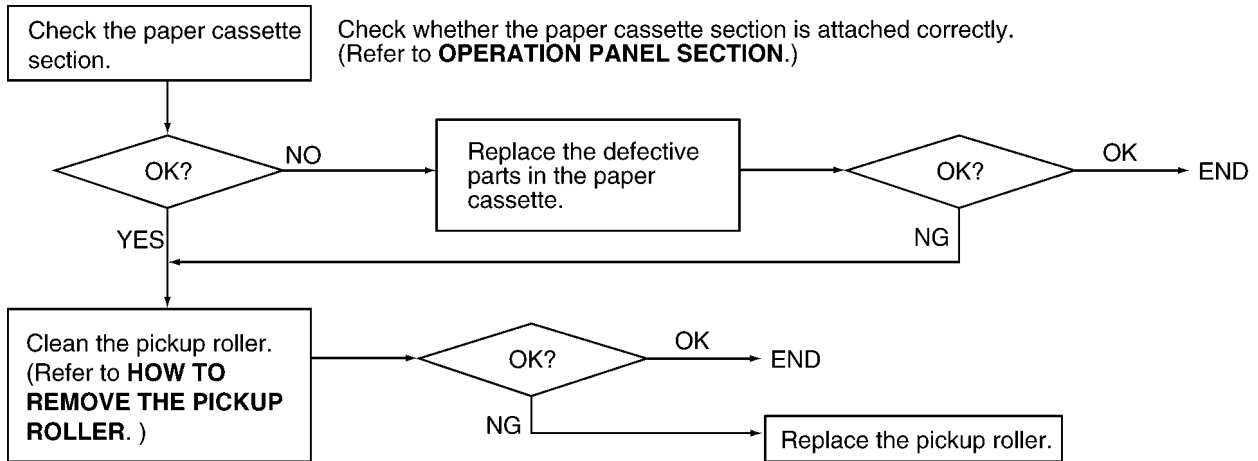

**CROSS REFERENCE:**

HOW TO REMOVE THE PICKUP ROLLER (P.38)

OPERATION PANEL SECTION (P.166)

### 6.6.4.8. THE SENT FAX DATA IS SKEWED

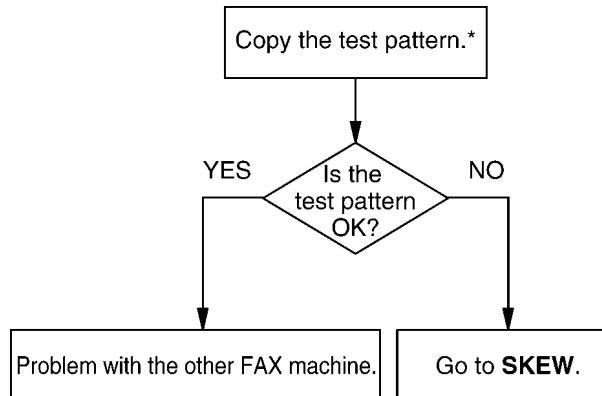

\* We recommend making a copy of the Fig. B document in **MULTIPLE FEED**(P.64) and using it.

**CROSS REFERENCE:**

SKEW (P.65)

### 6.6.4.9. THE RECEIVED FAX DATA IS SKEWED

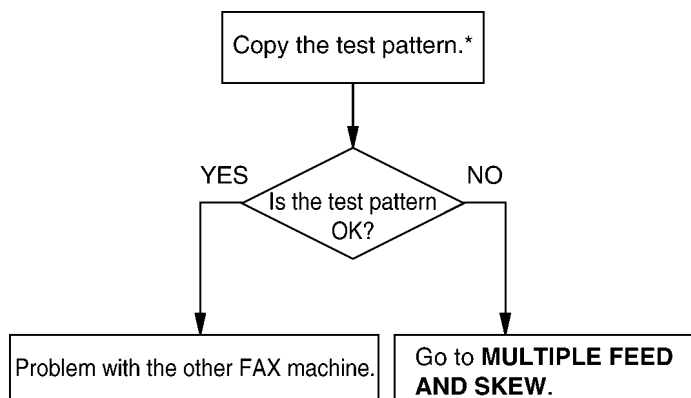

\* We recommend making a copy of the Fig. B document in **MULTIPLE FEED**(P.64) and using it.

**CROSS REFERENCE:**

MULTIPLE FEED AND SKEW (P.68)

### 6.6.4.10. RECEIVED OR COPIED DATA IS EXPANDED

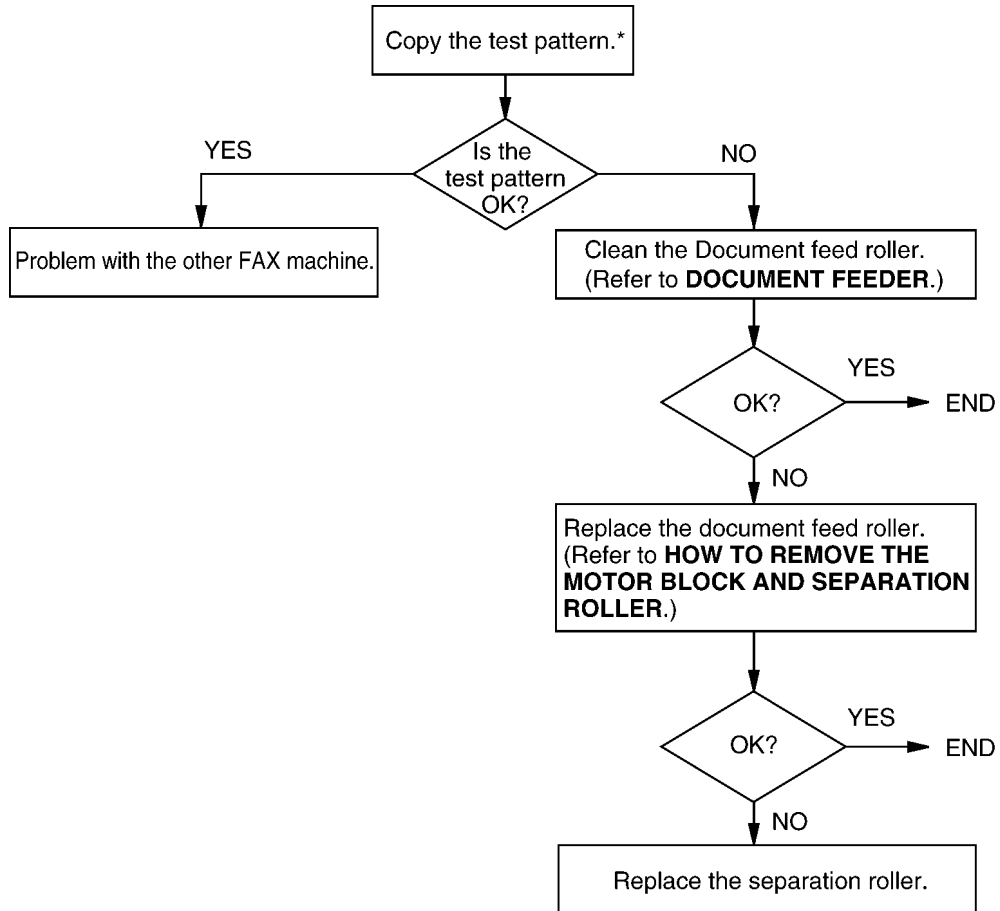

\* We recommend making a copy of the Fig. B document in **MULTIPLE FEED**(P.64) and using it.

#### CROSS REFERENCE:

**DOCUMENT FEEDER** (P.27)

**HOW TO REMOVE THE MOTOR BLOCK AND SEPARATION ROLLER** (P.42)

### 6.6.4.11. A BLANK PAGE IS COPIED

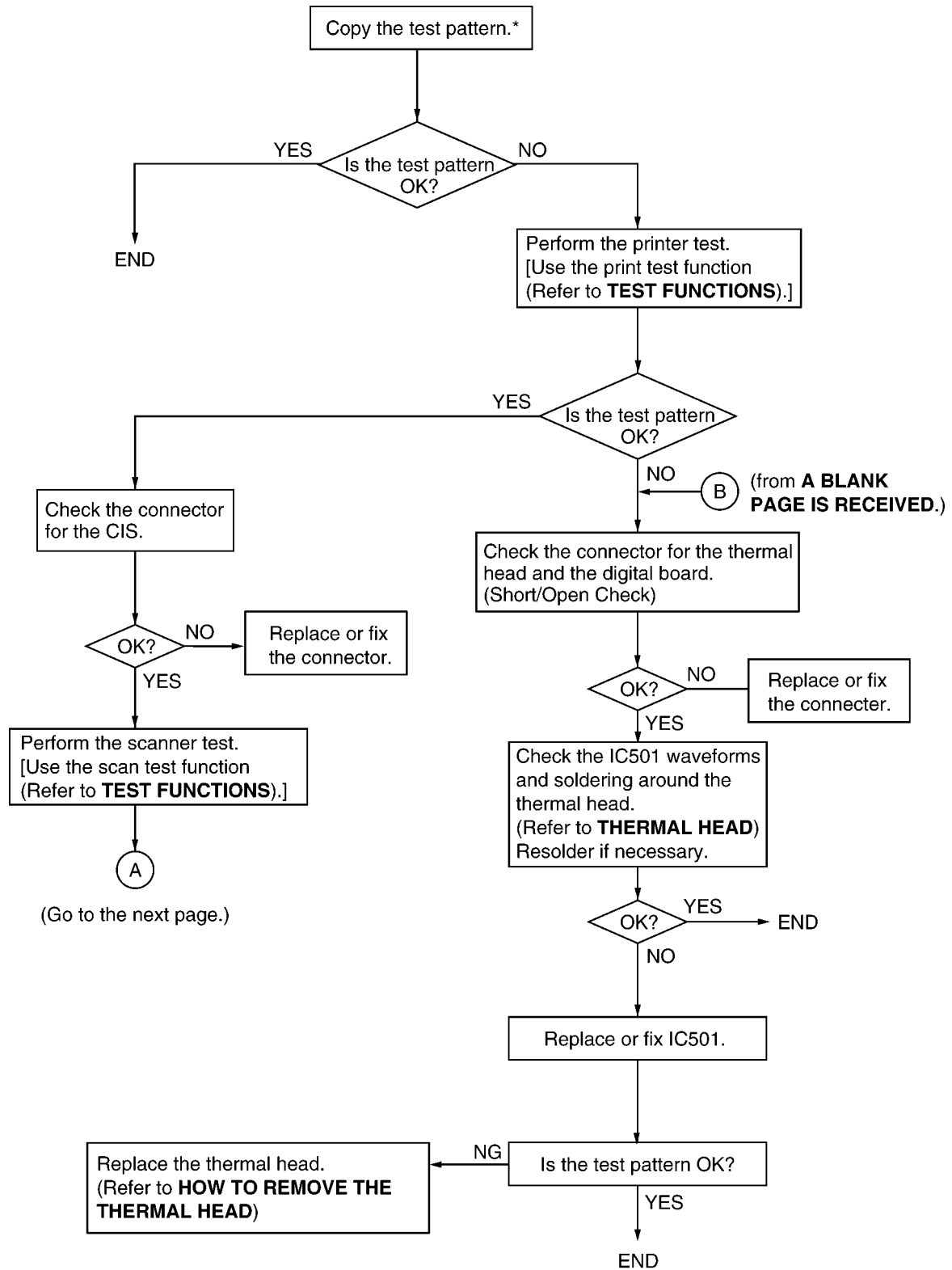

\* We recommend making a copy of the Fig. B document in **MULTIPLE FEED** (P.64) and using it.

**CROSS REFERENCE:**

- HOW TO REMOVE THE THERMAL HEAD** (P.36)
- TEST FUNCTIONS** (P.50)
- A BLANK PAGE IS RECEIVED** (P.72)
- THERMAL HEAD** (P.129)

(From the previous)

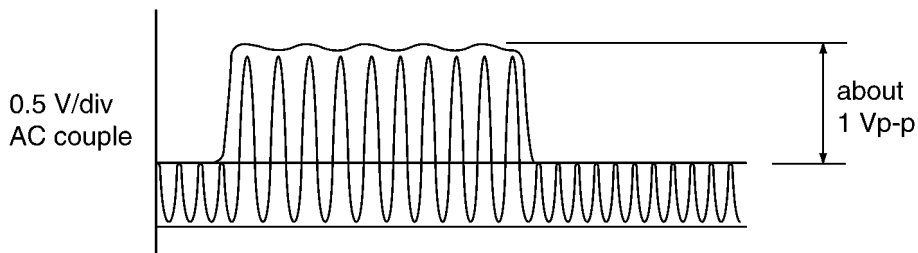
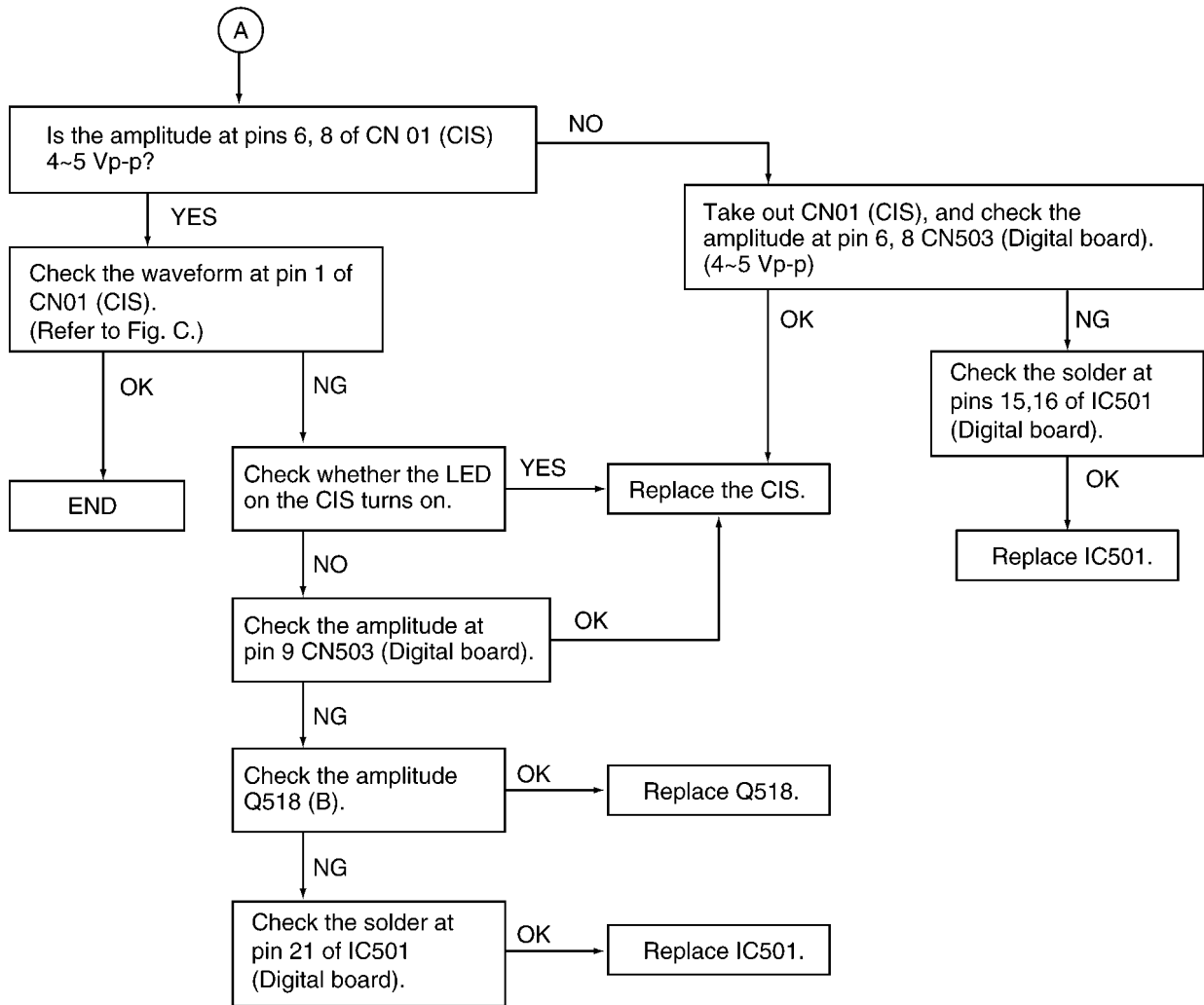

### 6.6.4.12. A BLANK PAGE IS RECEIVED

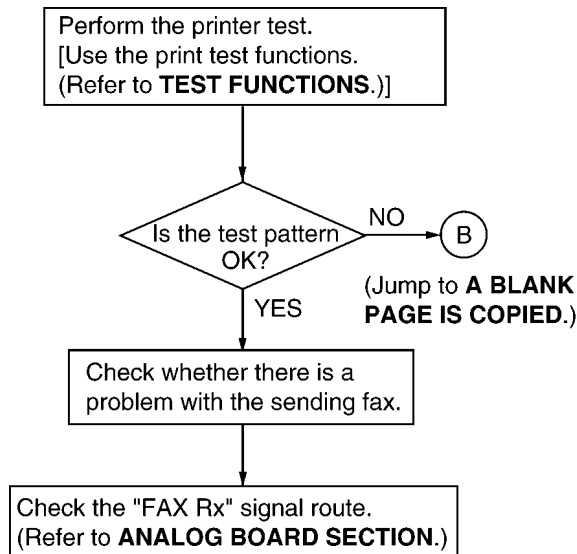

**CROSS REFERENCE:**

**TEST FUNCTIONS** (P.50)

**A BLANK PAGE IS COPIED** (P.70)

**ANALOG BOARD SECTION** (P.105)

### 6.6.4.13. BLACK OR WHITE VERTICAL LINE

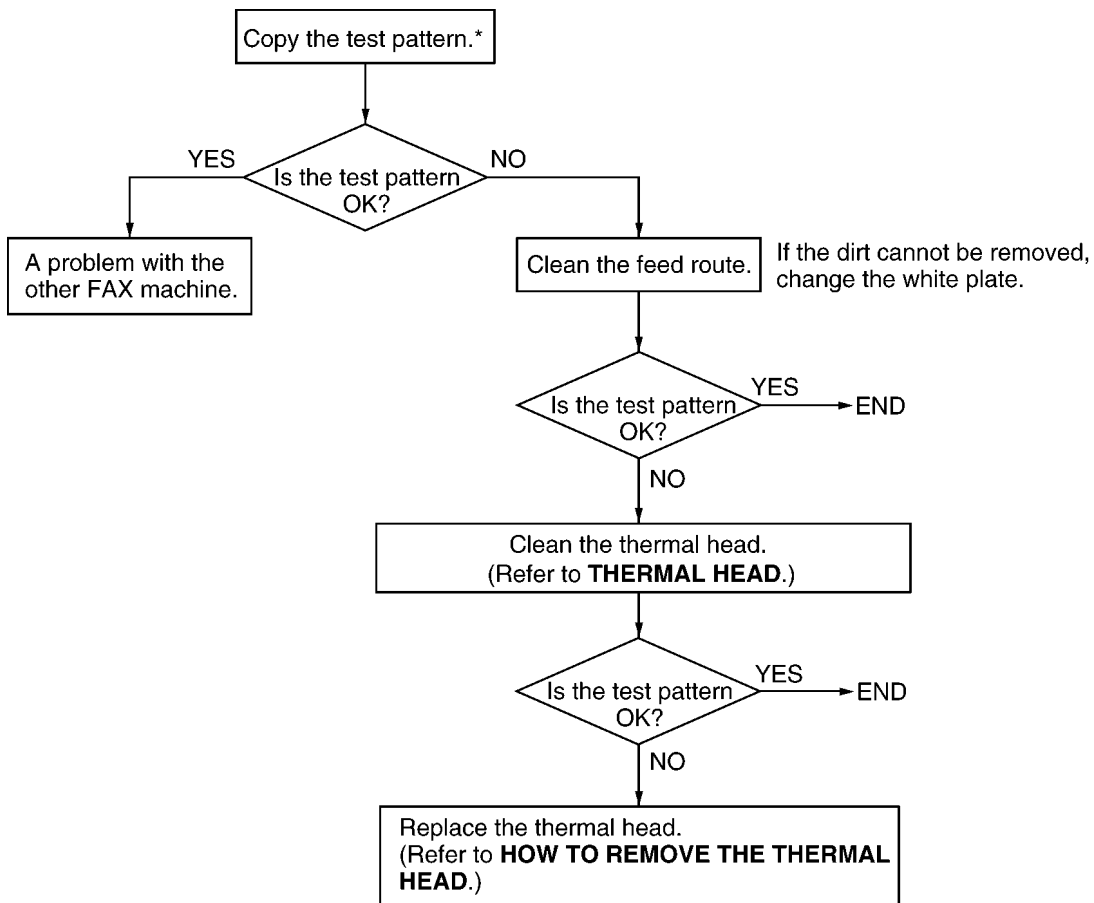

\* We recommend making a copy of the Fig. B document in **MULTIPLE FEED** (P.64) and using it.

**CROSS REFERENCE:**

**THERMAL HEAD** (P.28)

**HOW TO REMOVE THE THERMAL HEAD** (P.36)



### 6.6.4.14. BLACK OR WHITE LATERAL LINE ON PRINT OUT

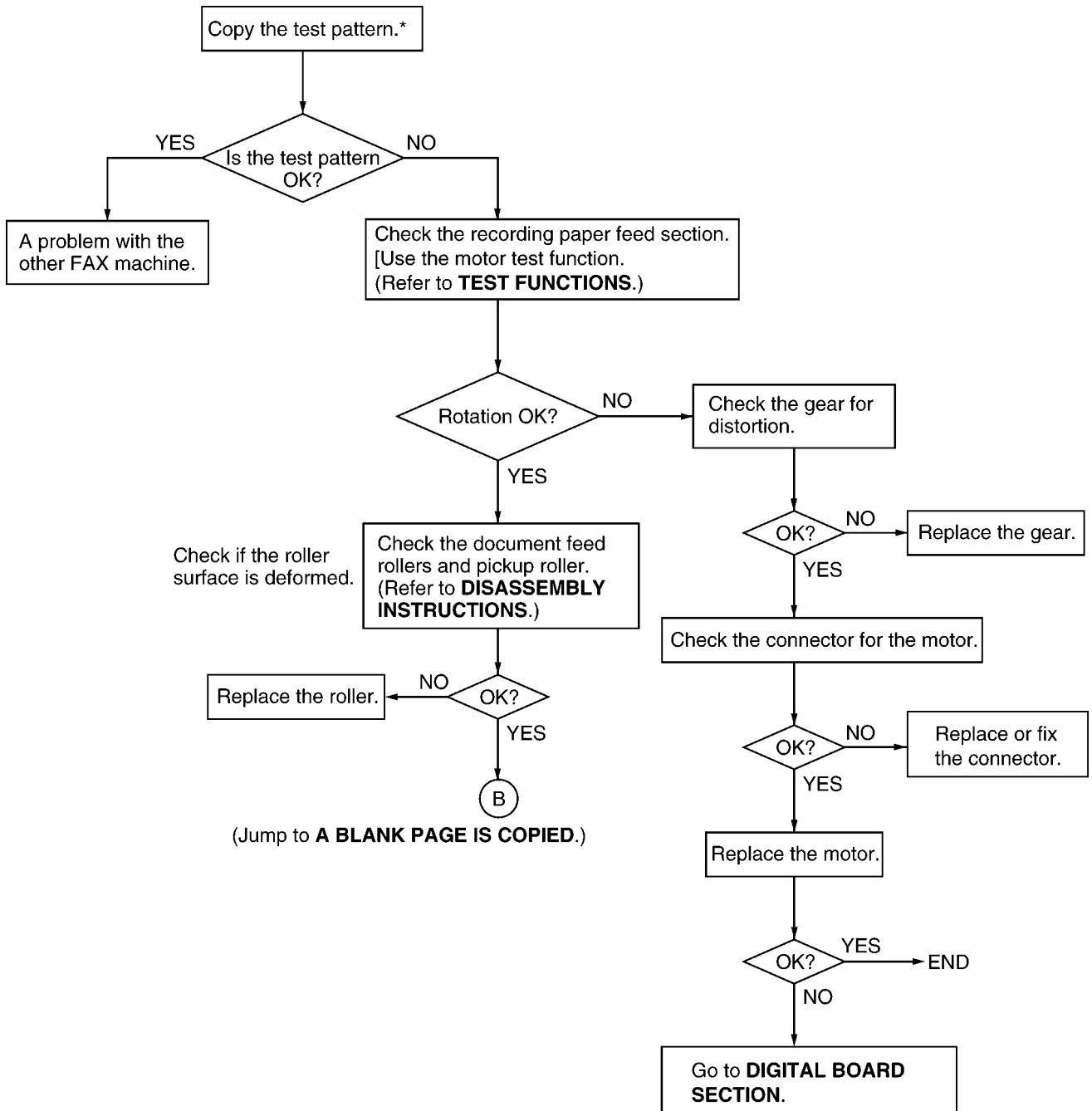

\* We recommend making a copy of the Fig. B document in **MULTIPLE FEED**(P.64) and using it.

**CROSS REFERENCE:**

**DISASSEMBLY INSTRUCTIONS** (P.30)

**TEST FUNCTIONS** (P.50)

**A BLANK PAGE IS COPIED** (P.70)

**DIGITAL BOARD SECTION** (P.97)

### 6.6.4.15. AN ABNORMAL IMAGE IS PRINTED

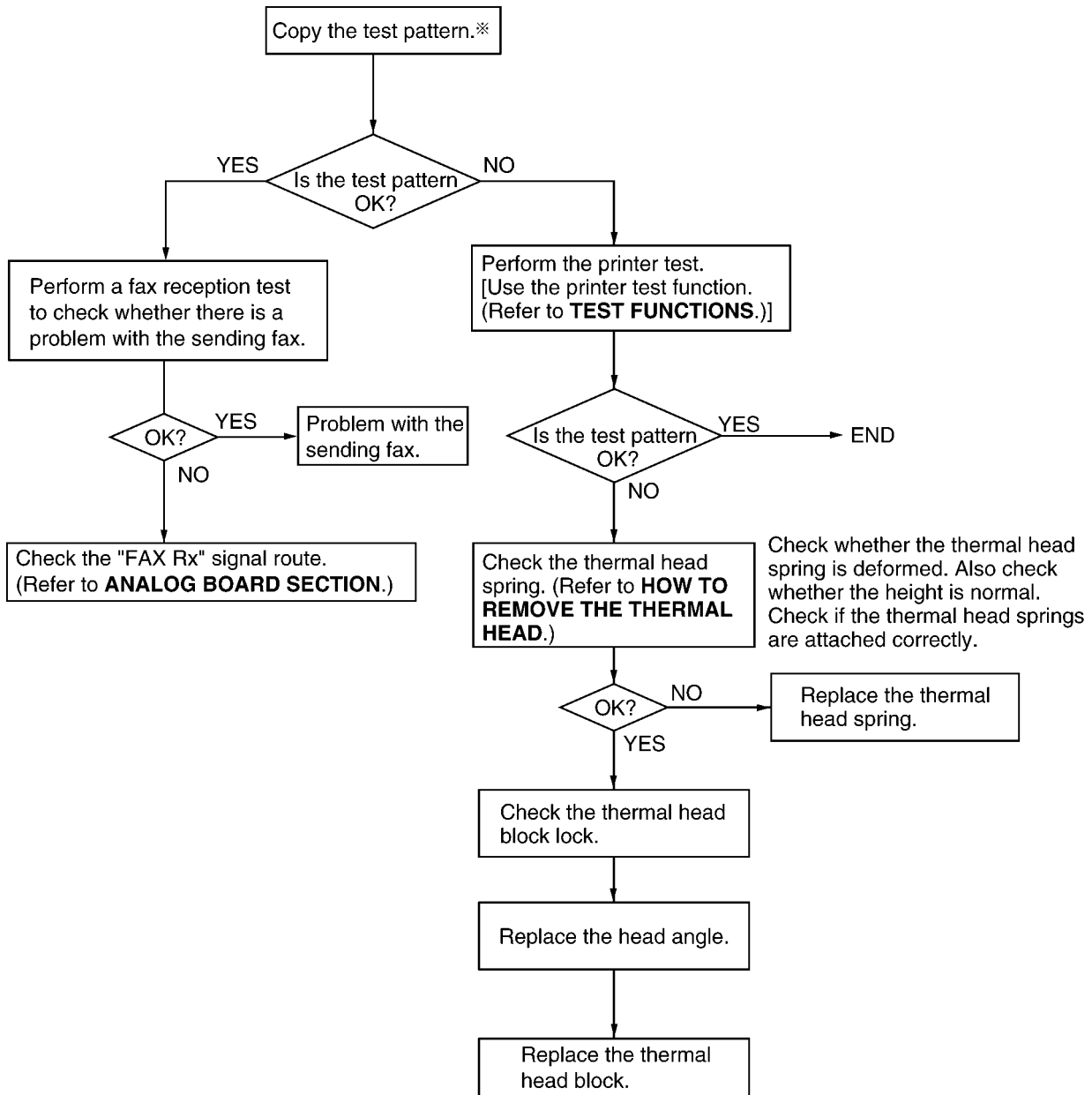

\* We recommend making a copy of the Fig. B document in **MULTIPLE FEED** (P.64) and using it.

**CROSS REFERENCE:**

**HOW TO REMOVE THE THERMAL HEAD** (P.36)

**TEST FUNCTIONS** (P.50)

**ANALOG BOARD SECTION** (P.105)

## 6.6.5. COMMUNICATION SECTION

Find the problem in the table shown below, and refer to the corresponding troubleshooting procedure in **DEFECTIVE FACSIMILE SECTION ( P.76)**.

No.	Symptom	Content	Possible cause
1	The paper is not fed properly when faxing. (Nor in the copy mode.)	Troubleshooting	Problem with the feeding mechanism.
2	The fax usually transmits successfully but sometimes fails. (The unit can copy documents.)	Troubleshooting	Problem with the service line or with the receiver's fax.
3	The fax usually receives successfully but sometimes fails. (The unit can copy documents.)	Troubleshooting	Problem with the service line or with the transmitter's fax.
4	The fax completely fails to transmit or receive. (The unit can copy documents.)	Troubleshooting	Problem with the electric circuit.
5	The fax fails either to transmit or receive when making a long distance or an international call. (The unit can copy documents.)	Detailed description of the possible causes (Similar to troubleshooting items No.2 and No.3.)	Problem with the service line.
6	The fax image is poor when transmitting or receiving during a long distance or an international call.		
7	No.1-No.5	The troubleshooting procedure for each error code will be printed on the communication result report.	

### 6.6.5.1. DEFECTIVE FACSIMILE SECTION

#### 6.6.5.1.1. TRANSMIT PROBLEM

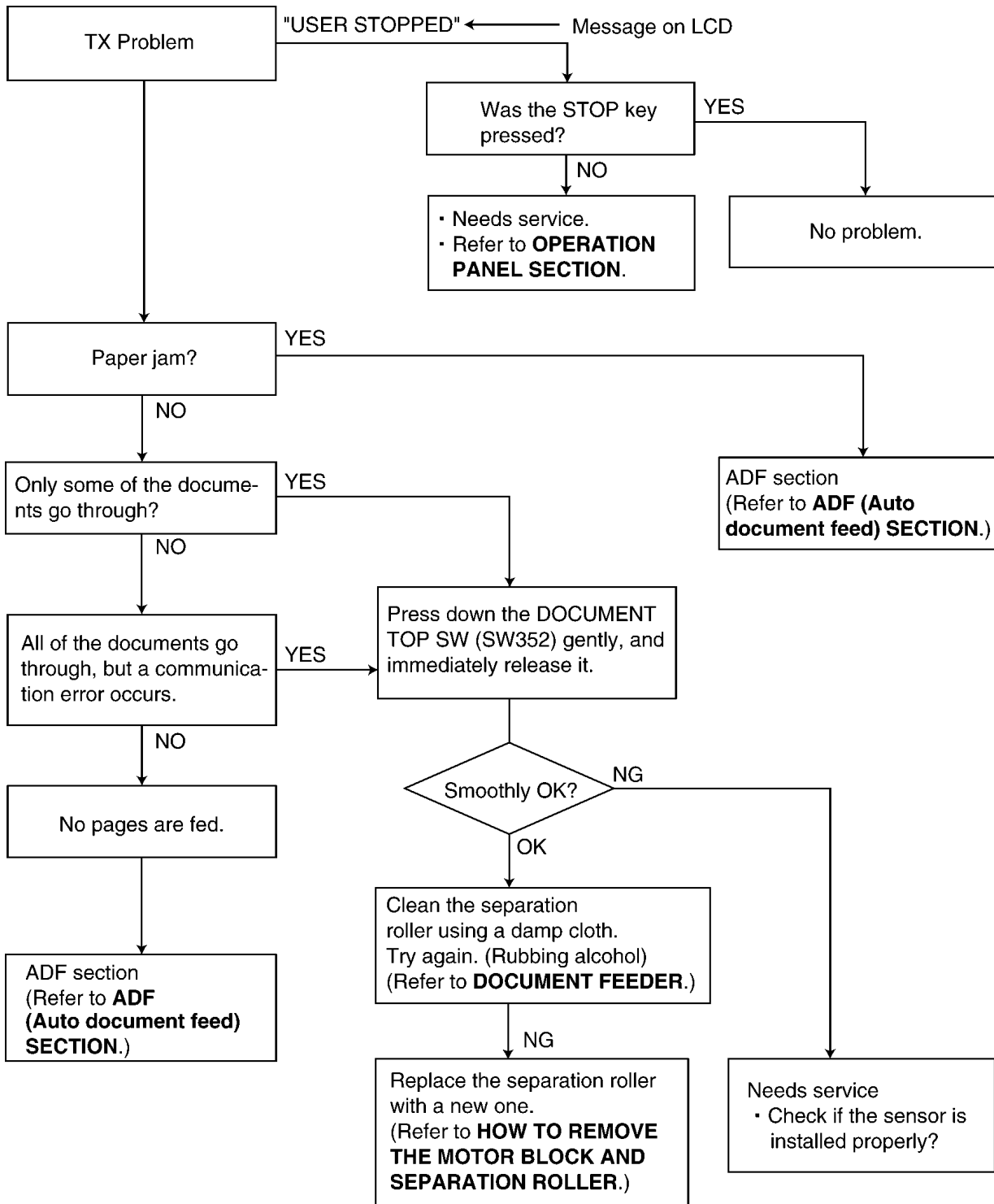

**CROSS REFERENCE:**

**DOCUMENT FEEDER (P.27)**

**HOW TO REMOVE THE MOTOR BLOCK AND SEPARATION ROLLER (P.42)**

**ADF (Auto Document Feed) SECTION (P.62)**

**OPERATION PANEL SECTION (P.111)**

### 6.6.5.1.2. SOMETIME THERE IS A TRANSMIT PROBLEM

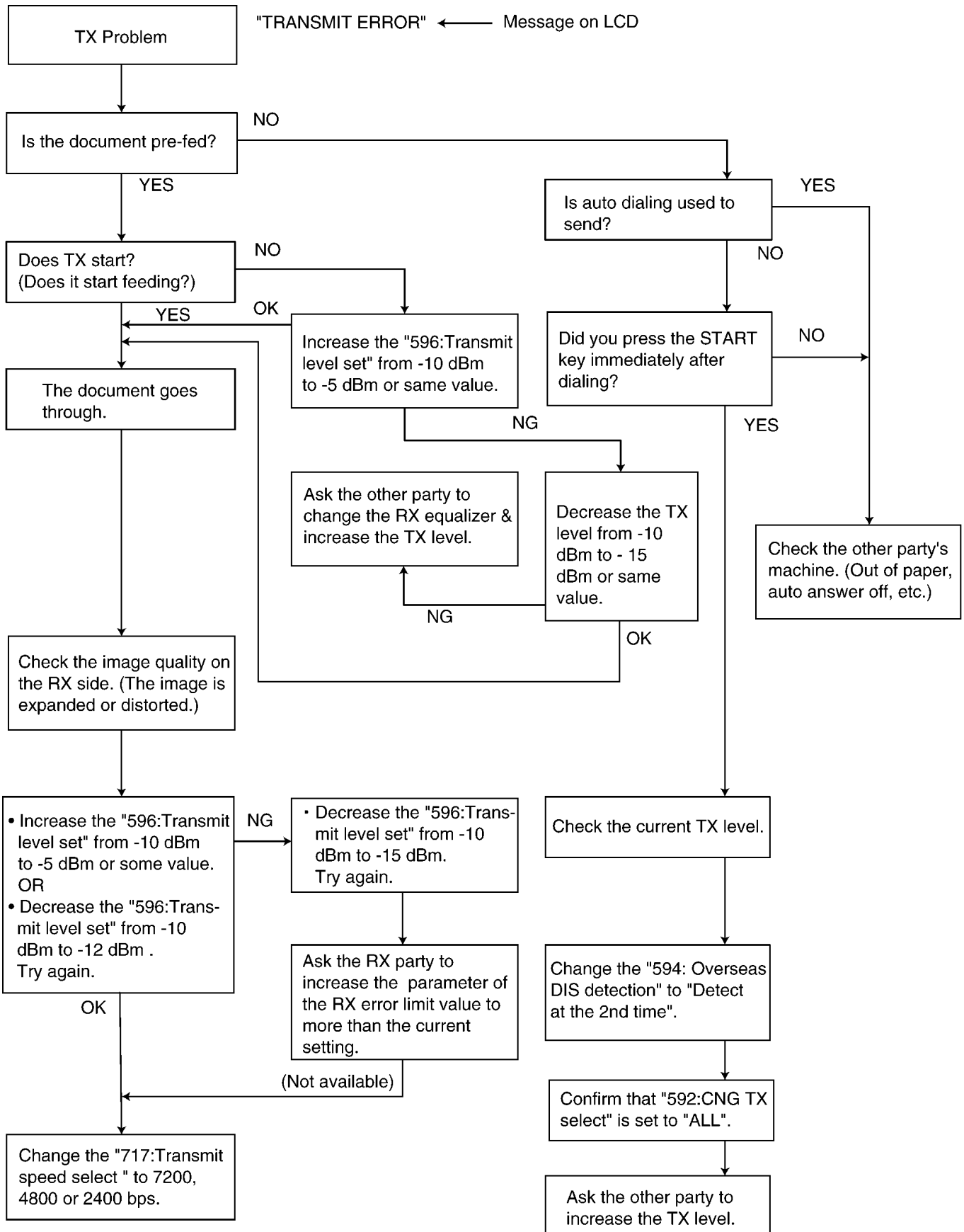

**Note:**

"596: Transmit level set" represents a service code. (Refer to **SERVICE FUNCTION TABLE (P.48)**.)

### 6.6.5.1.3. RECEIVE PROBLEM

First confirm whether the recording paper is installed properly or not before starting troubleshooting. (Refer to "Remarks".)

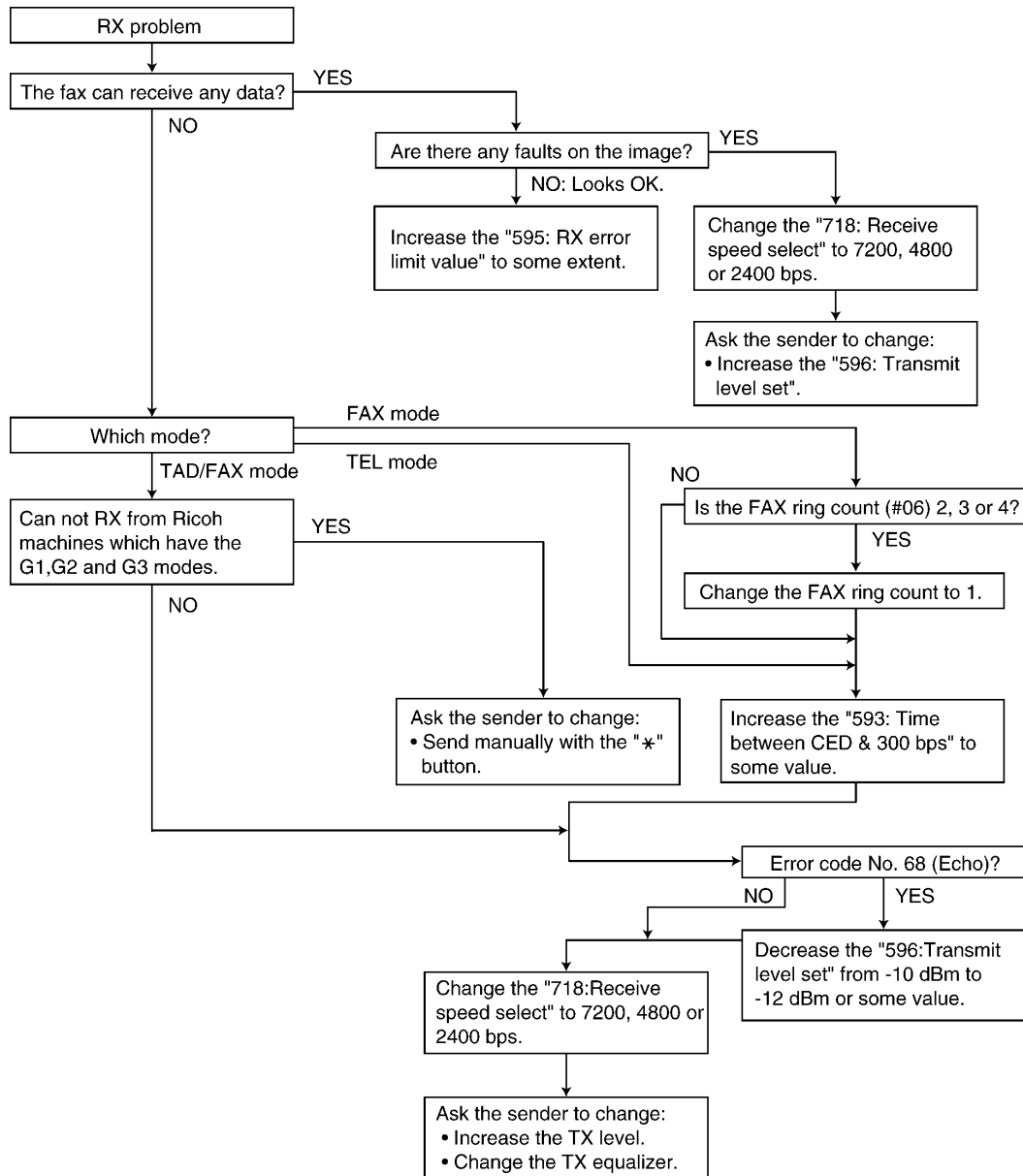

#### Note:

"596: Transmit level set" represents a service code. (Refer to **SERVICE FUNCTION TABLE (P.48)**.)

#### Remarks:

Regarding the reception problem, we have investigated the conceivable causes in the flow chart except for the software-related errors. However, some troubles may occur due to the software-related problems such as "OUT OF PAPER" when the fax switches to the memory receiving mode and the memory capacity becomes full of the unprintable data. In this case, error messages [MEMORY FULL] and its main cause, for example "CHECK PAPER" are displayed on the LCD. Once you solve the main problem, [MEMORY FULL] will be cancelled and the reception problem will be resolved.

LCD display messages indicating the error causes are shown below.

CHECK PAPER

COVER OPEN

UNIT OVERHEATED (COVER OPEN, etc.)...Reset the unit.

PAPER JAMMED

CHECK FILM

Please refer to **USER RECOVERABLE ERRORS (P.45)** for the above items. If it turns out to be a hardware deformity, please check each sensor. (Refer to **TEST FUNCTIONS (P.50)**.)

### 6.6.5.1.4. THE UNIT CAN COPY, BUT CANNOT TRANSMIT/RECEIVE

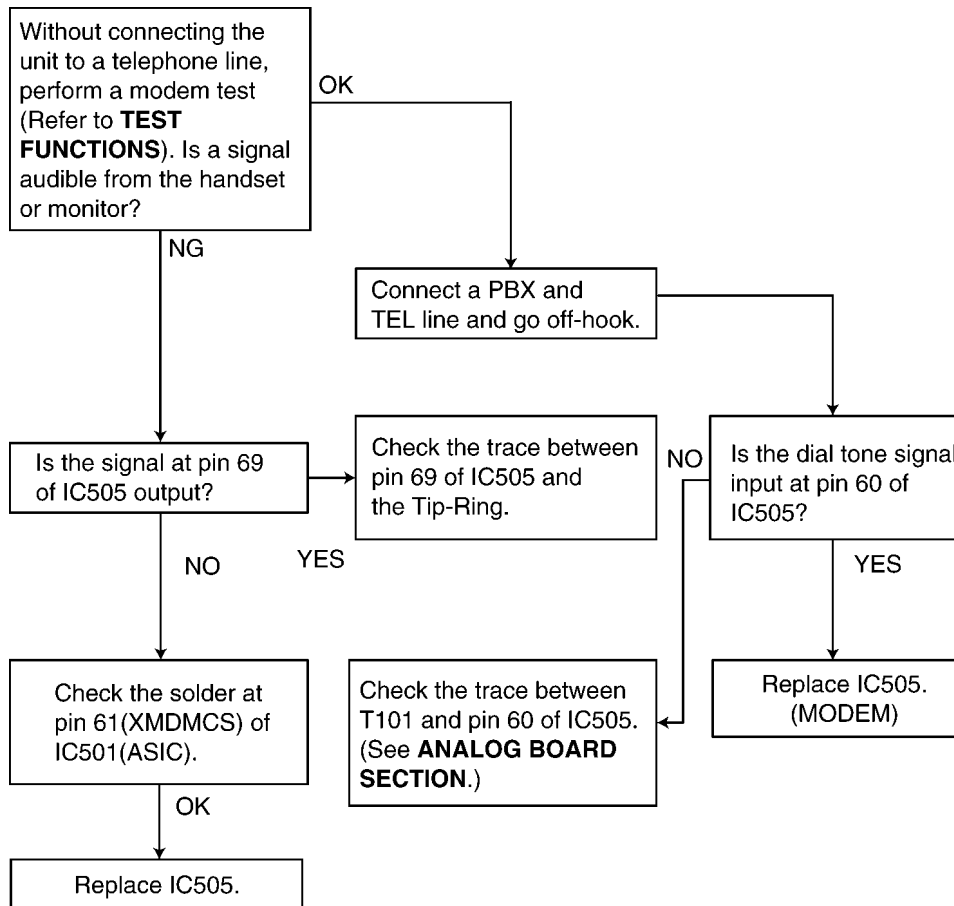

**CROSS REFERENCE:**

**TEST FUNCTIONS** (P.50)

**ANALOG BOARD SECTION** (P.105)

### 6.6.5.1.5. THE UNIT CAN COPY, BUT CANNOT EITHER TRANSMIT/RECEIVE LONG DISTANCE OR INTERNATIONAL COMMUNICATIONS

The following two causes can be considered for this symptom.

**Cause 1:**

The other party is executing automatic dialing, the call has been received by this unit, and the CED or DIS signal response time is too long. (In most cases, this unit detects the CNG signal and can respond to CED or DIS.) (According to the ITU-T standard, the communication procedure is cancelled when there is no response from the other party within 35 sec, so that the other party releases the line.)

(Response Time)

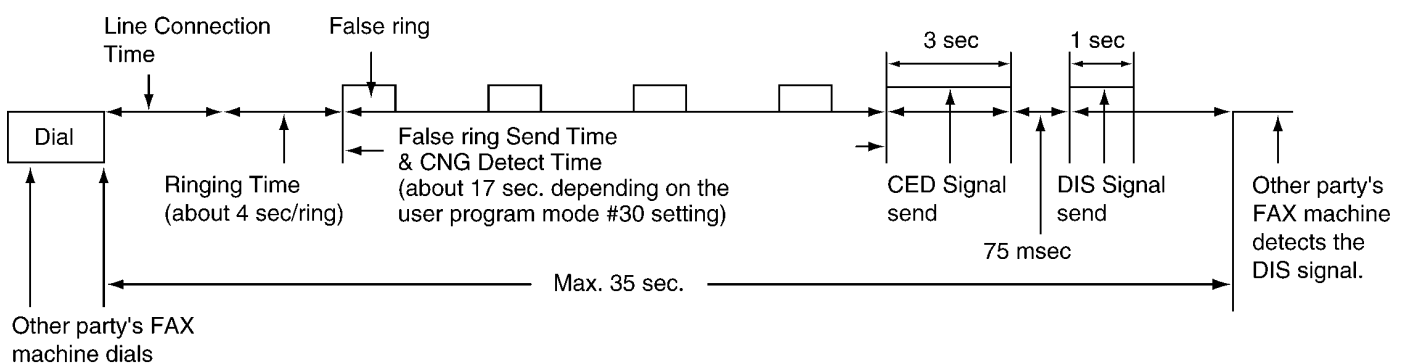

**(Cause and Countermeasure)**

As shown in the chart above, the total handshaking time must be reduced, but because of the long distance connection and linking of several stations, the line connection time cannot be reduced. Accordingly, the following countermeasures should be tried.

(A)... As the 35 sec. count is started directly after dialing or directly after the START button has been pressed for models with a START button, the other party should be called manually, if possible. Another possibility is entering two pauses at the end of the auto dial number on the transmission side. Then the count start time can be delayed for 2 pauses (about 10 sec.).

**Cause 2:**

Erroneous detection because of an echo or an echo canceler.

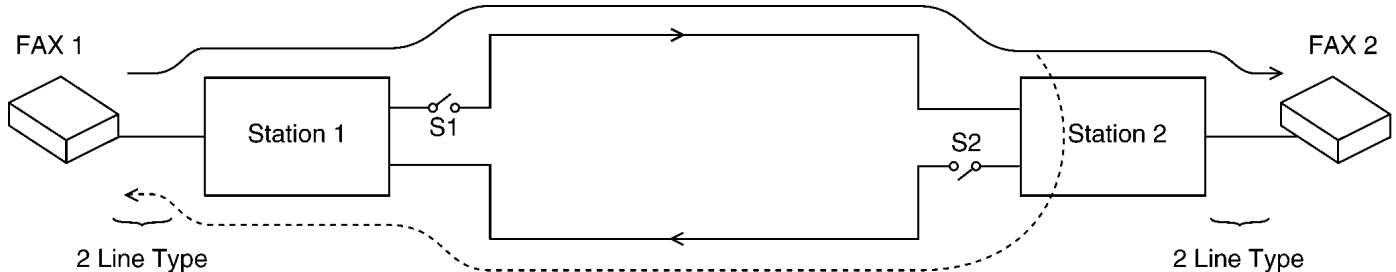
**(Echo/Echo Canceler)**

The signal from FAX1 reaches FAX2 via stations 1 and 2, but the reflection signal at station 2 also returns via station 1 (echo). As the distance between station 1 and station 2 is far, the echo returns to FAX 1 at a max of 600 msec after transmission. There is a possibility that this signal is detected erroneously as the signal from FAX2. For a normal call, there is also a possibility that the echo of their own voice will make the call difficult to understand. For this reason, each station (station 1 and station 2) attaches echo cancelers (S1 and S2) for international lines or long distance lines. For the echo canceler, the level of the transmission signal from FAX 1 is compared with the level of the reception signal from FAX2. When the transmission signal is larger, S1 is closed while S2 is opened when it is smaller. In other words, for transmission from FAX1, S1 is closed and S2 is open, so that the echo does not return to FAX1.



**(Causes and Countermeasures)**

No.	Countermeasure Side	Echo Communication Problem Example	Countermeasure	Service Code
1	Sending side	Some time is needed to compare the level of the receiving and sending signals for the echo canceler. The header of the training signal lacks due to a switching delay to close S1.	Add a dummy signal to the beginning of the training signal.	Service code (521) (International mode select) This countermeasure becomes the default value.
2	Receiving side	The echo canceler function stops according to a CED signal frequency of 2100Hz (S1 and S2 are both ON), a DIS signal is returned as an echo, and a DCS signal from the sending side overlaps the DIS echo. Then the receiving side FAX cannot retrieve the DCS signal. (Refer to Fig. a)	Change to a 1100Hz CED signal frequency. (Refer to Fig. b)	Service code (520) (CED frequency select)
	Receiving side		Change the regular time of 75 msec between the CED signal and DIS signal to 500 msec. This will give at least 250 msec to recover the echo canceler operation. (Refer to Fig. c)	Service code (593) (Time between CED and 300 bps)
	Sending side		The sending side FAX sends a DCS signal not after receiving the 1st DIS signal but after receiving the 2nd DIS signal. (Refer to Fig. d)	Service code (594) (Overseas DIS detection select)
3	Sending side	Communication failure occurs in a long distance communication on the telephone line without an echo canceler.	Decrease the transmission level from -10 dBm to -15 dBm and the echo level will decrease.	Service code (596) (Transmit level set)
4	Sending side Receiving side	or	Decrease the receiving sensitivity from -13 dBm to about -32 dBm so an echo signal will not be received.	Service code (598) (Receiving sensitivity)
5	Sending side Receiving side	There are some cases (e.g. Mobil comms.) which cause the collision of TX / RX signals due to the delay / echo and noise of the network / terminal. (Refer to Fig. e)	Set additional Pause time (Service mode: code No. 774) in between the original and its repeated signals, to prevent the collision of the signals at both end.	Service code (774) (T4 timer)

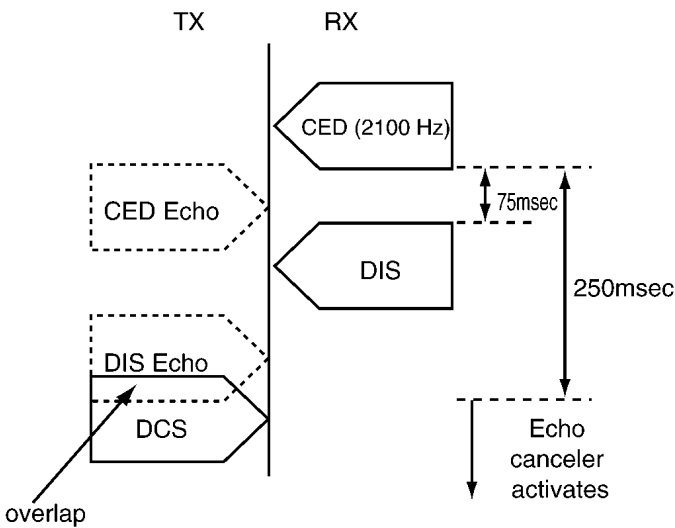

Fig. a (Overlapping the Echo of the DIS signal and DCS signal)

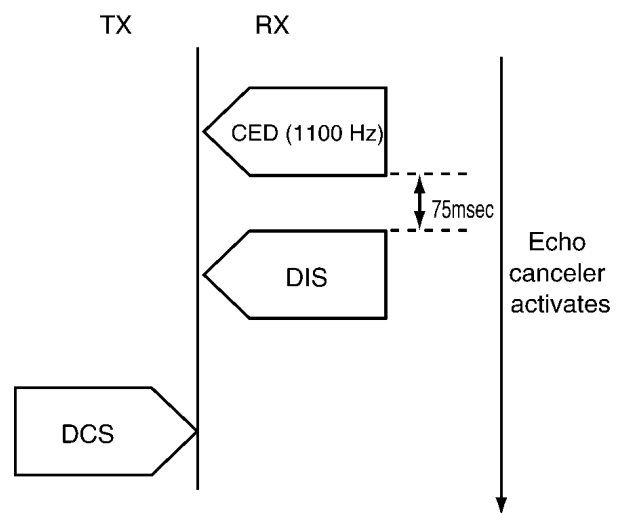

Fig. b (Countermeasure by Changing the CED Frequency)

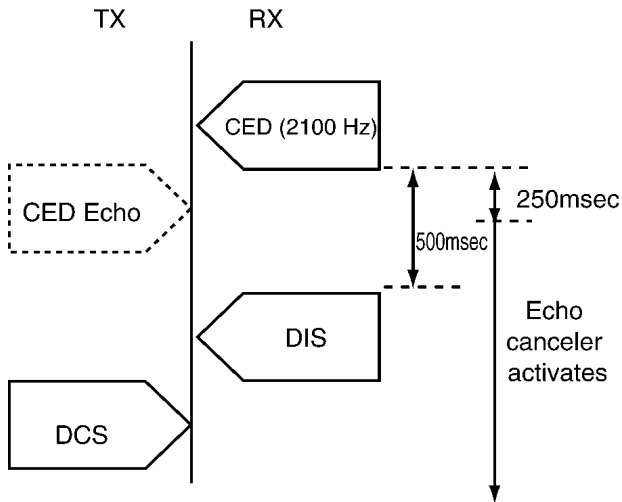

Fig. c (Countermeasure by Changing the Interval Between CED and DIS)

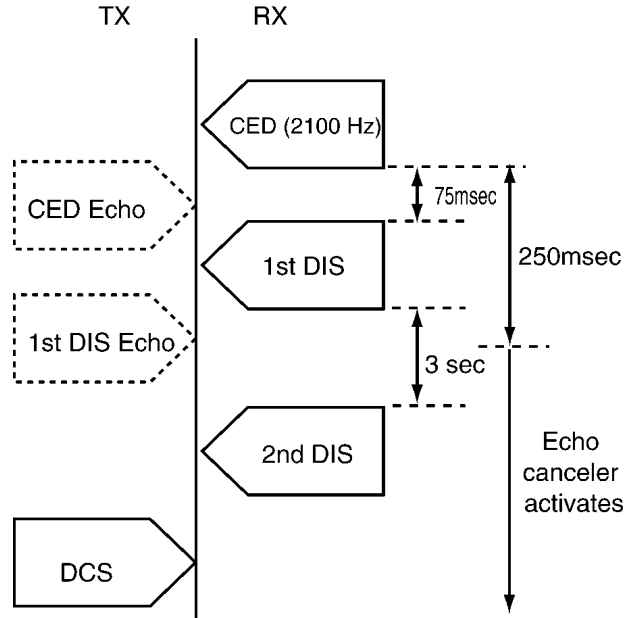
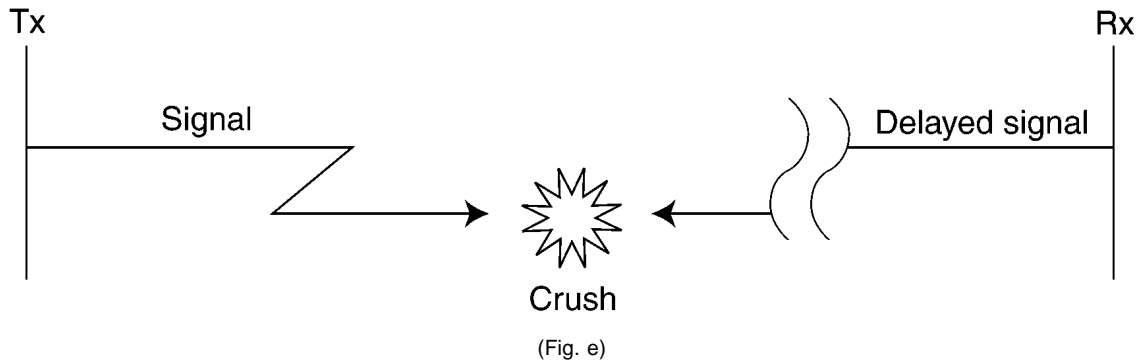

Fig. d (Countermeasure by Ignoring the 1st DIS)

<TX side signal>	<RX side signal>	<Countermeasure>
2nd / 3rd DCS / Training	& delayed CFR / FTT	at TX side
2nd / 3rd EOP / EOM / MPS	& delayed MCF / PIP / PIN / RTP / RTN	at TX side
delayed DCS	& 2nd / 3rd / --- DIS	at RX side



### 6.6.5.1.6. THE UNIT CAN COPY, BUT THE TRANSMISSION AND RECEPTION IMAGE ARE INCORRECT

(Long distance or international communication operation)

This symptom highly depends on the transmission and reception capability of the other FAX unit and the line conditions. The countermeasures for this unit are shown below.

#### Transmission Operation:

Set the transmitting speed to 4800BPS (service mode: code No. 717) or select the overseas mode.

#### Reception Operation:

If 80% or more of the reception is incorrect, set the receiving speed to 4800BPS. (Service mode: code No. 718)

- Refer to **SERVICE FUNCTION TABLE** (P.48).

### 6.6.5.1.7. HOW TO RECORD FAX SIGNAL BY USING PC

Recording FAX signal is one of the useful analysis measures to solve communication problems.

The way of recording easily by using PC is shown as follows.

#### 1. Equipment

- 1 jig
- 1 PC (with LINE IN)
- 1 audio cord (mini jack supported)
- 2 tel cords

Parts No.	Parts Name & Description	Qt'y
PQJJ1T004Z	JACK1, JACK2	2
PQJJ1D010Z	PIN JACK	1
ECQE2155KF or ECQE2E155KC	CAPACITOR	2
MA4020	DIODE	2

#### 2. Setting up

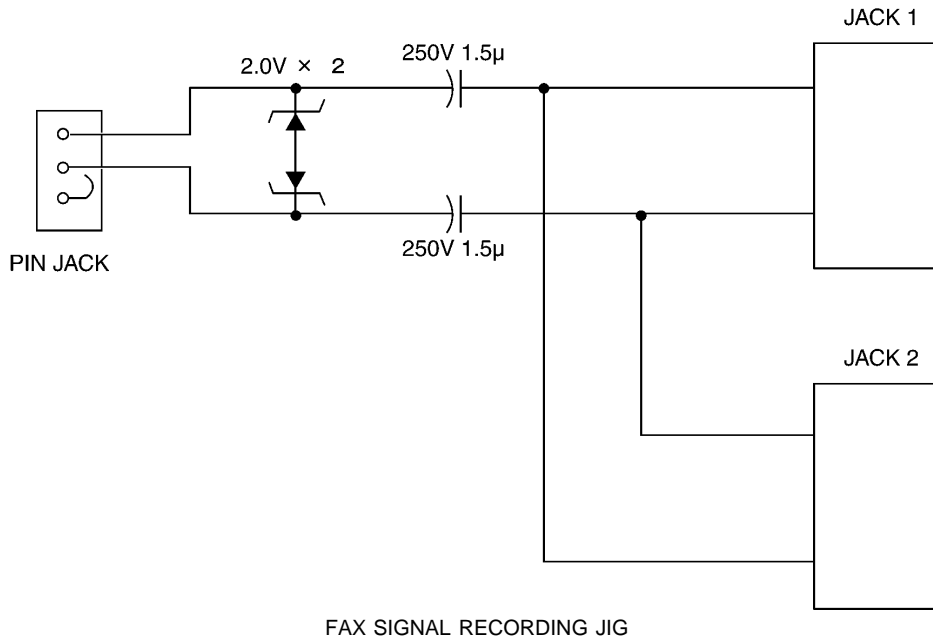

#### 3. Connecting PC and JIG

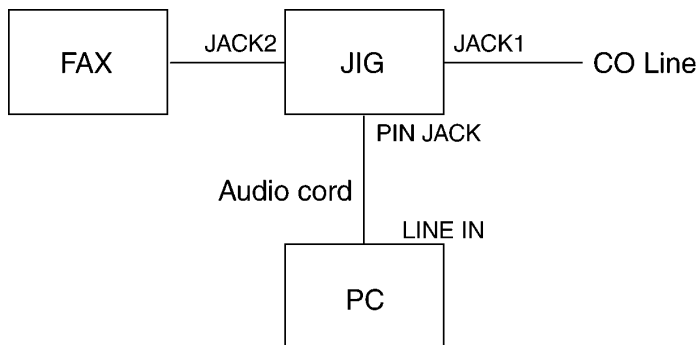

#### 4. PC setting and recording

1. Set LINE IN to be valid in the volume control setting.  
Refer to the PC instruction book.
2. Start up the PC software " SOUND RECORDER". (This software is bundled to Windows OS, which can create WAV file.)  
Set the audio format " PCM 22.050kHz, 8bit, mono".
3. Click the record button and start recording after acquisition the signal.

#### Note:

- Not to be wind wave patterns on the wave monitor.
- Please compress the recording data when you send attaching to E-Mail because the data size will be so heavy.
- Any software which can create WAV files is available.

### 6.6.5.1.8. HOW TO OUTPUT THE JOURNAL REPORT

1. Press [MENU] button.
2. Press [#], then [8] and [4].
3. Press [SET] button.
4. The report is printed out.

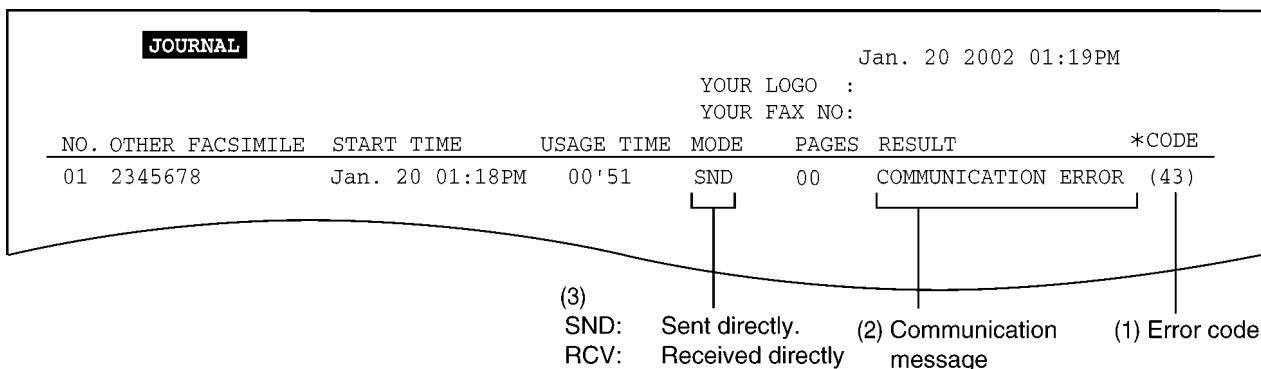

**Error code table:**

(1) CODE	(2) RESULT	(3) MODE	SYMPTOM	Counter-measure*
	PRESSED THE STOP KEY	SND & RCV	Communication was interrupted by the STOP button.	
	DOCUMENT JAMMED	SND	The document paper is jammed.	
	NO DOCUMENT	SND	No document paper.	
28	COMMUNICATION ERROR	SND & RCV	-	
40	OTHER FAX NOT RESPONDING	SND	Transmission is finished when the T1 TIMER expires.	1
41	COMMUNICATION ERROR	SND	DCN is received after DCS transmission.	2
42	COMMUNICATION ERROR	SND	FTT is received after transmission of a 2400BSP training signal.	3
43	COMMUNICATION ERROR	SND	No response after post message is transmitted three times.	4
44	COMMUNICATION ERROR	SND	RTN and PIN are received.	5
46	COMMUNICATION ERROR	RCV	No response after FTT is transmitted.	6
48	COMMUNICATION ERROR	RCV	No post message.	7
49	COMMUNICATION ERROR	RCV	RTN is transmitted.	8
50	COMMUNICATION ERROR	RCV	PIN is transmitted (to PRI-Q).	8
51	COMMUNICATION ERROR	RCV	PIN is transmitted.	8
52	OTHER FAX NOT RESPONDING	RCV	Reception is finished when the T1 TIMER expires.	9
54	ERROR-NOT YOUR UNIT	RCV	DCN is received after DIS transmission.	11
58	COMMUNICATION ERROR	RCV	DCN is received after FTT transmission.	13
59	ERROR-NOT YOUR UNIT	SND	DCN responds to the post message.	14
65	COMMUNICATION ERROR	SND	DCN is received before DIS reception.	2
65	COMMUNICATION ERROR	RCV	Reception is not EOP, EOM PIP, PIN, RTP or RTN.	2
68	COMMUNICATION ERROR	RCV	No response at the other party after MCF or CFR is transmitted.	13
70	ERROR-NOT YOUR UNIT	RCV	DCN is received after CFR transmission.	13
72	COMMUNICATION ERROR	RCV	Carrier is cut when the image signal is received.	16
74	JUNK FAX PROH. REJECT	RCV	The junk fax prohibitor of your unit rejected fax reception.	
75	MEMORY FULL	RCV	The document was not received due to memory full.	
79	CANCELED	SND	The multi-station transmission was rejected by the user.	
FF	COMMUNICATION ERROR	SND & RCV	Modem error. For the DCN, DCN, etc. abbreviations, refer to <b>MODEM SECTION (P.138)</b> .	12

SND=TRANSMISSION RCV=RECEPTION

Most fax communication problems can be resolved by the following steps.

1. Change the transmit level. (Service code: 596, refer to **SERVICE FUNCTION TABLE (P.48)**.)
2. Change the TX speed/RX speed. (Service code: 717/718, refer to **SERVICE FUNCTION TABLE (P.48)**.)

**Note\*:**

If the problem remains, see the following "**Countermeasure**" flow chart.

Countermeasure

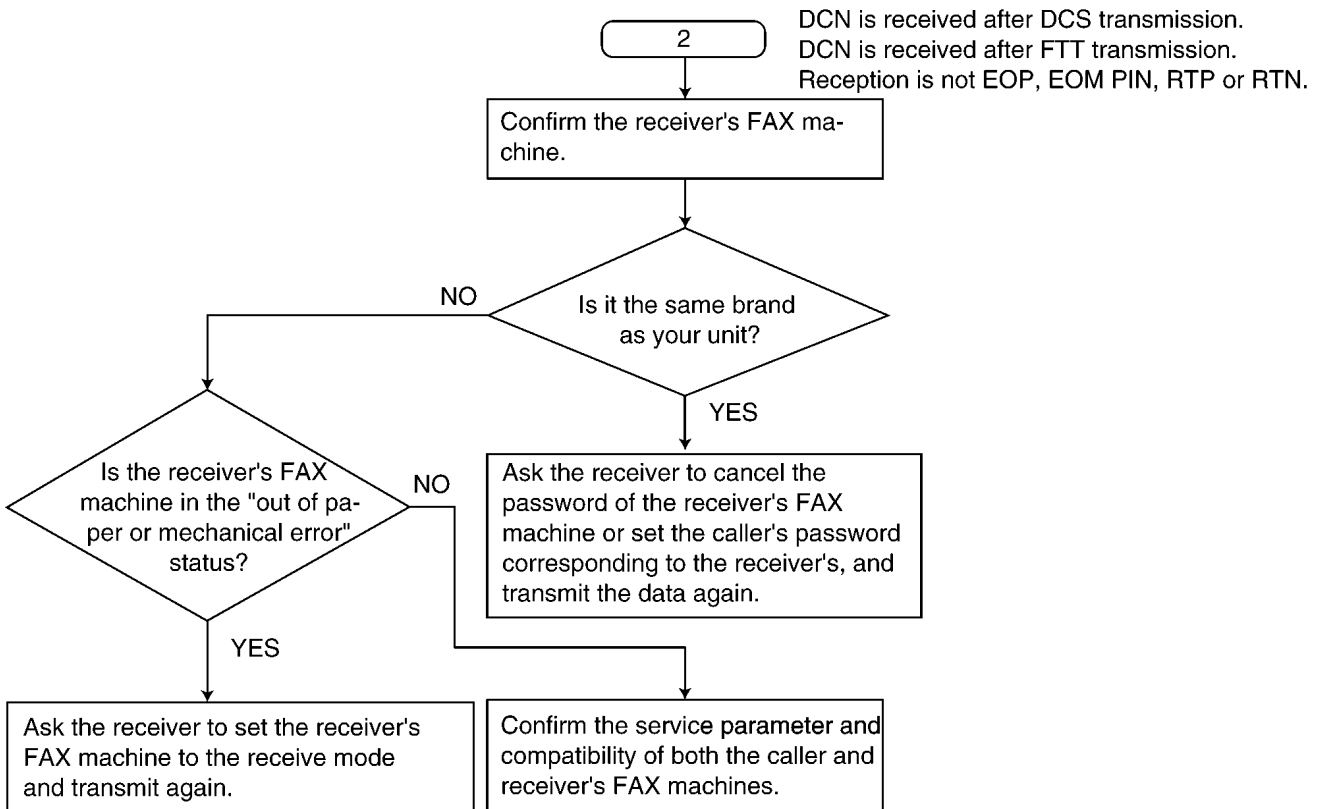
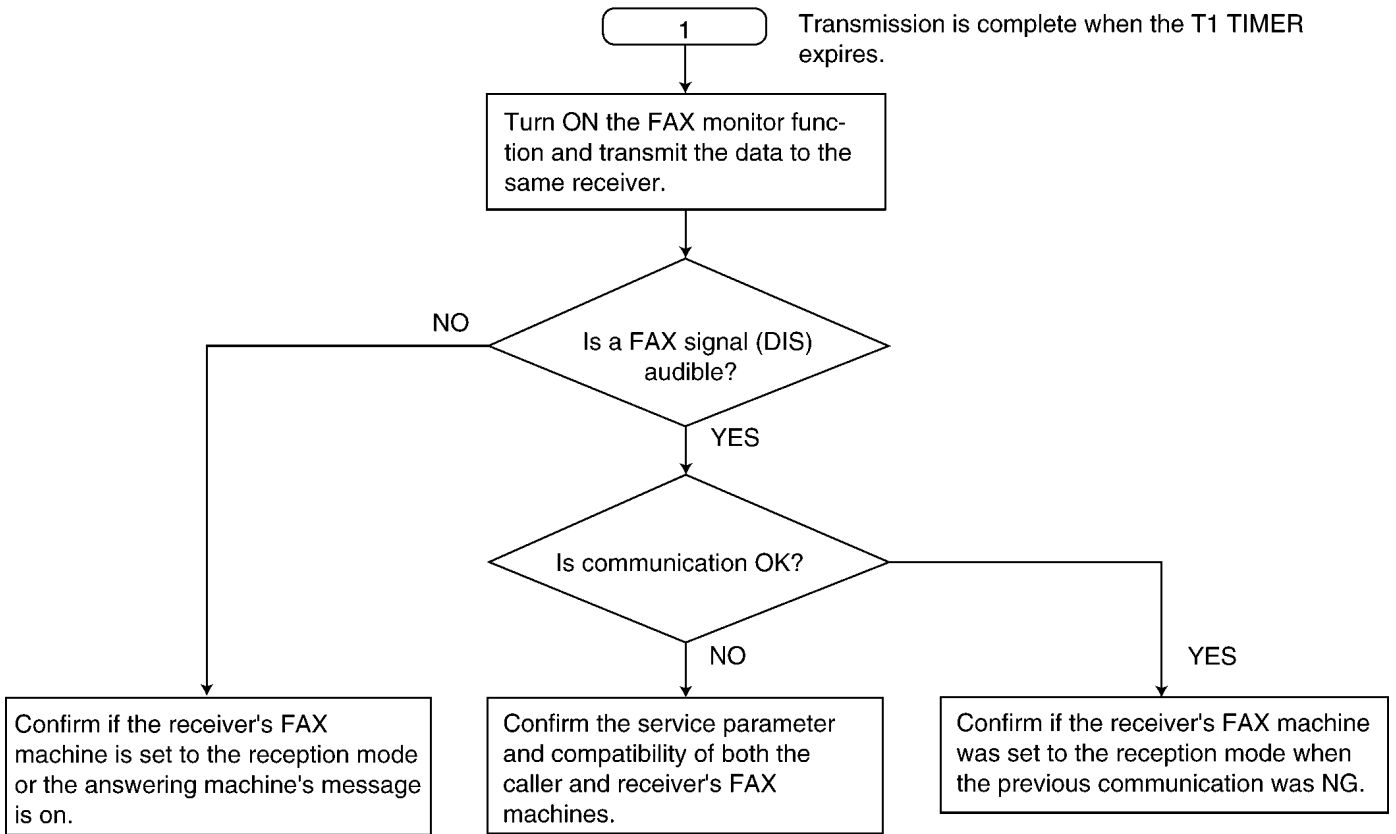

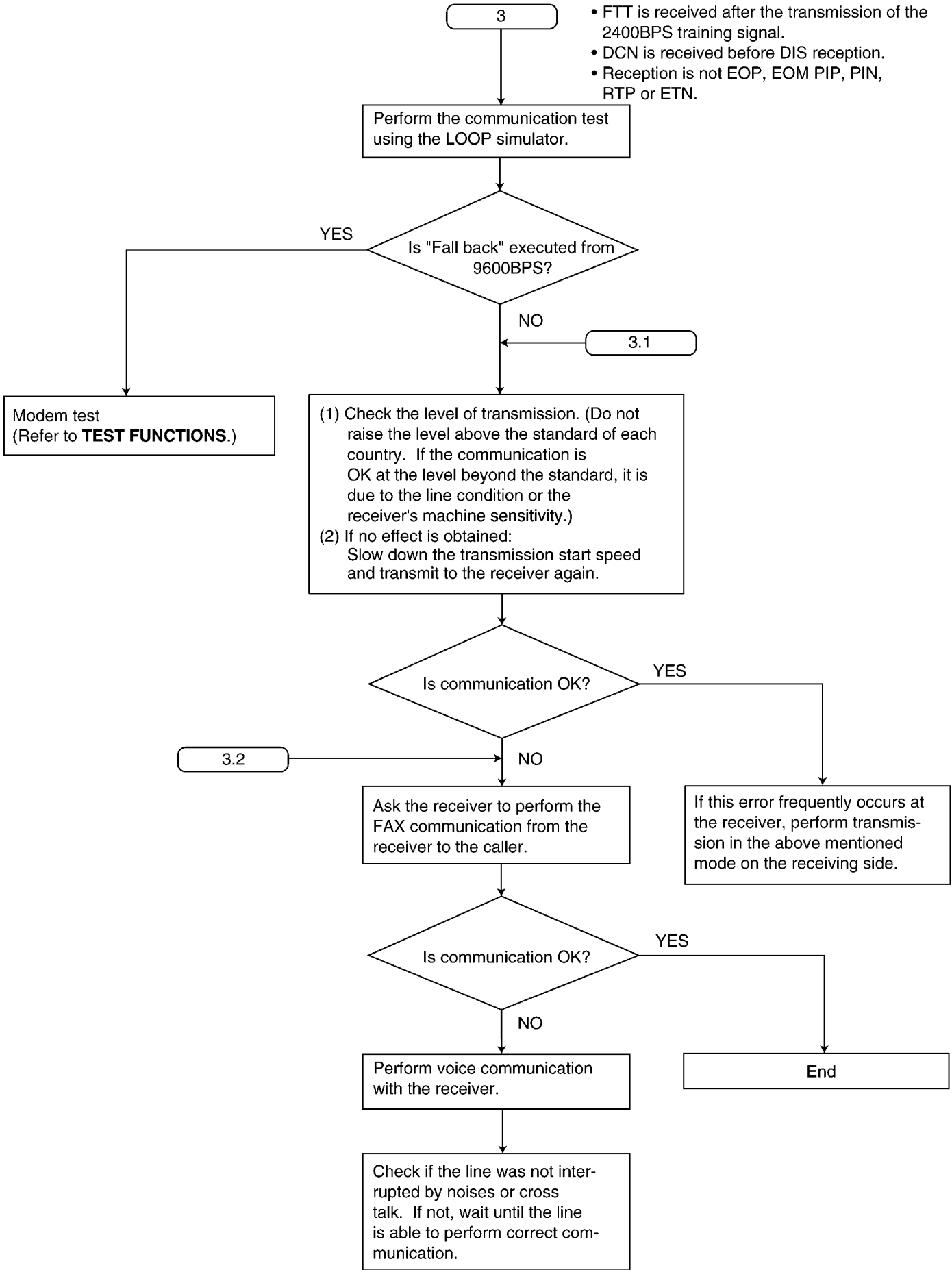

- FTT is received after the transmission of the 2400BPS training signal.
- DCN is received before DIS reception.
- Reception is not EOP, EOM PIP, PIN, RTP or ETN.

**CROSS REFERENCE:**  
**TEST FUNCTIONS (P.50)**

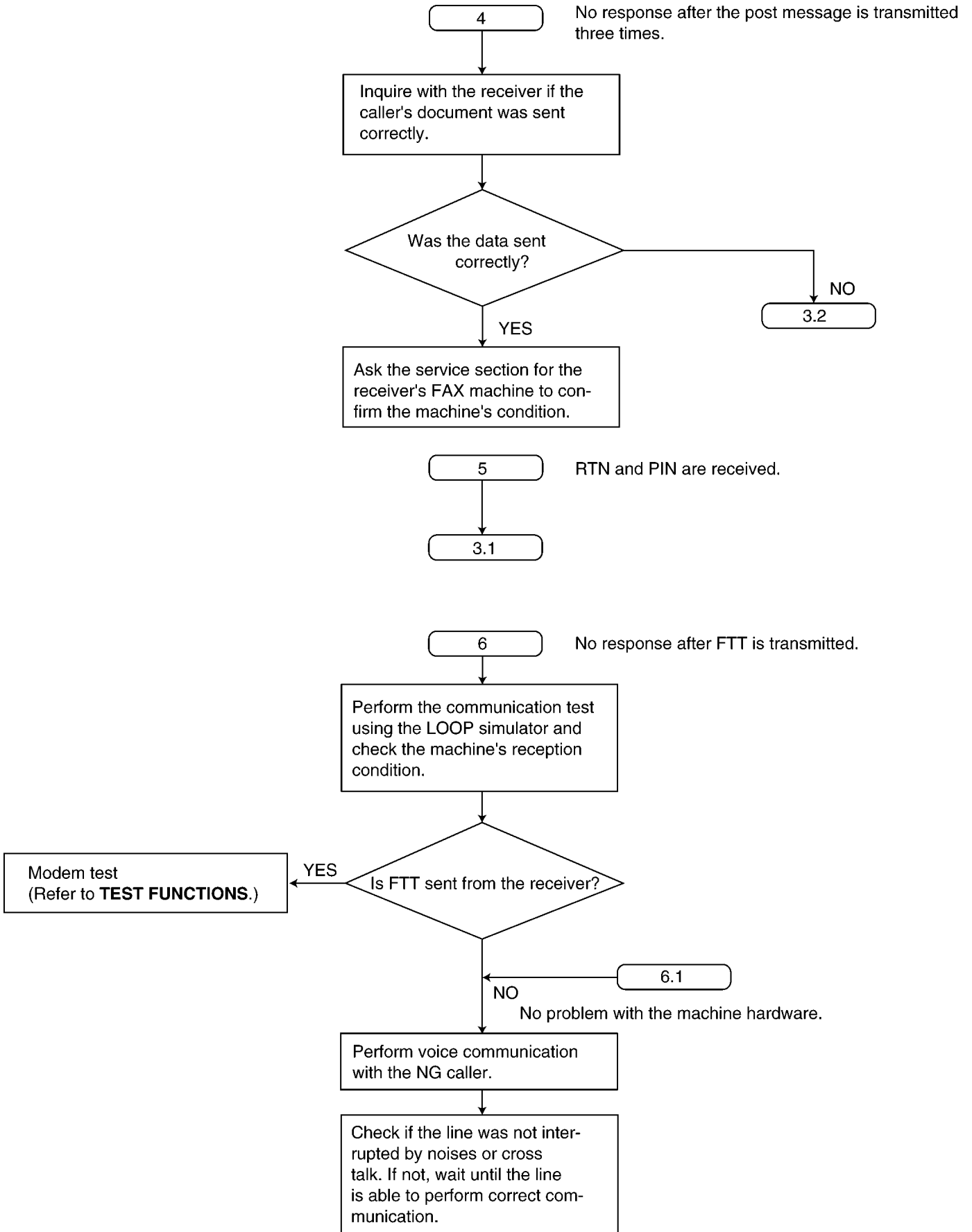

**CROSS REFERENCE:**  
**TEST FUNCTIONS (P.50)**

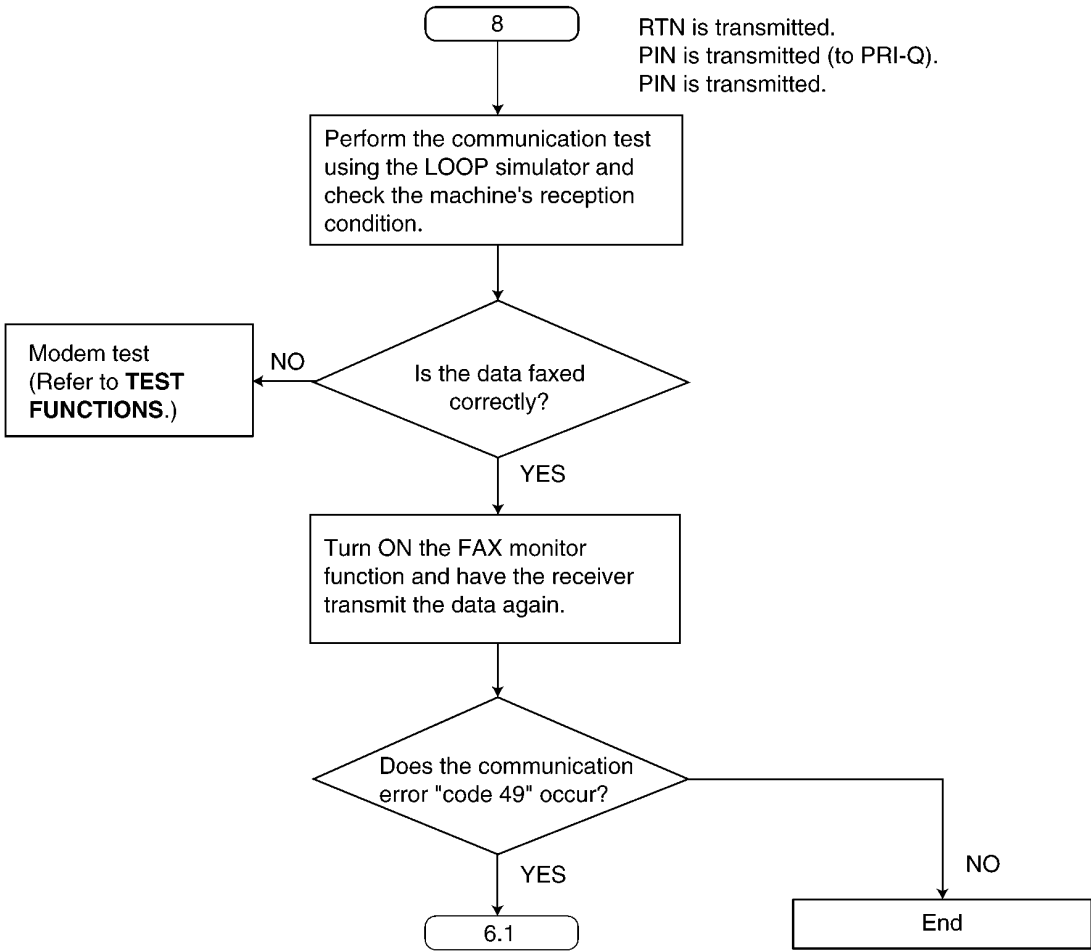
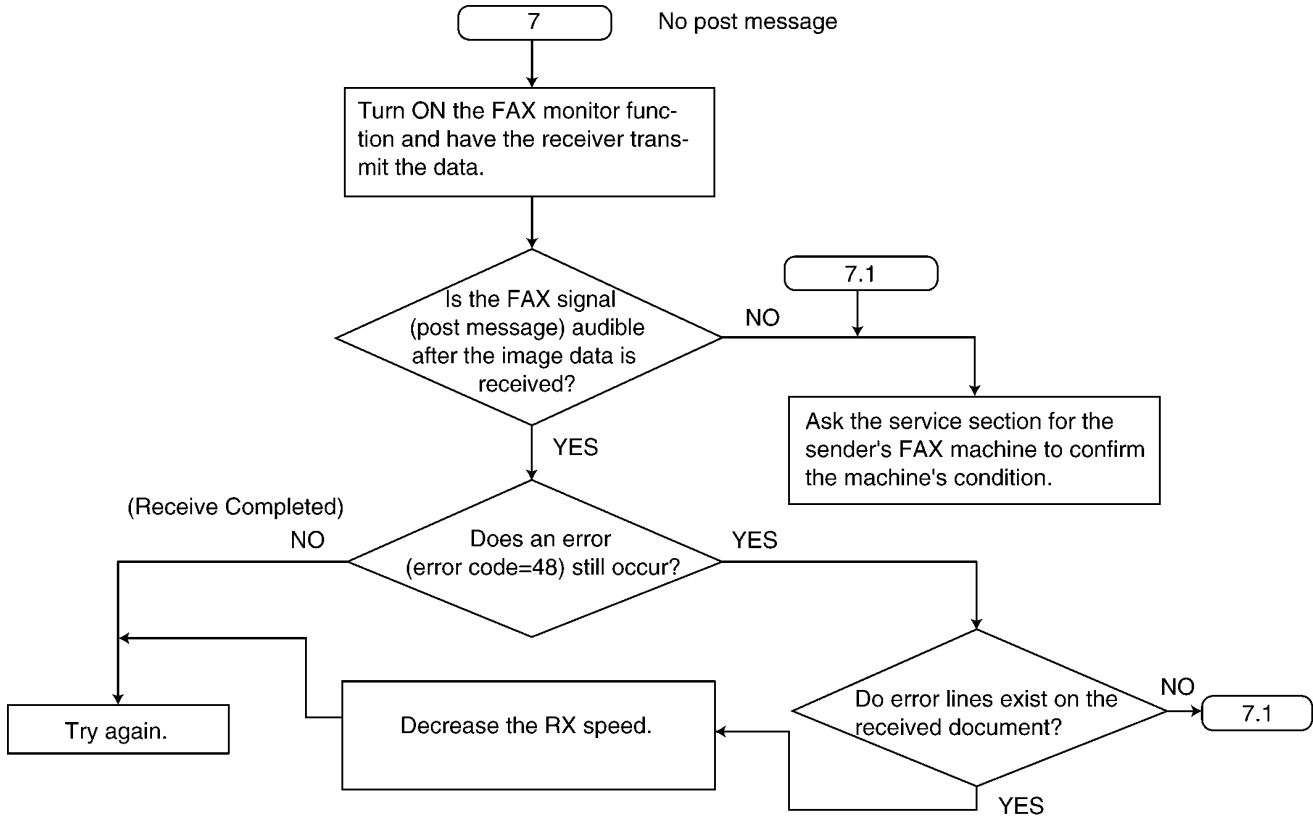

**CROSS REFERENCE:**  
**TEST FUNCTIONS (P.50)**



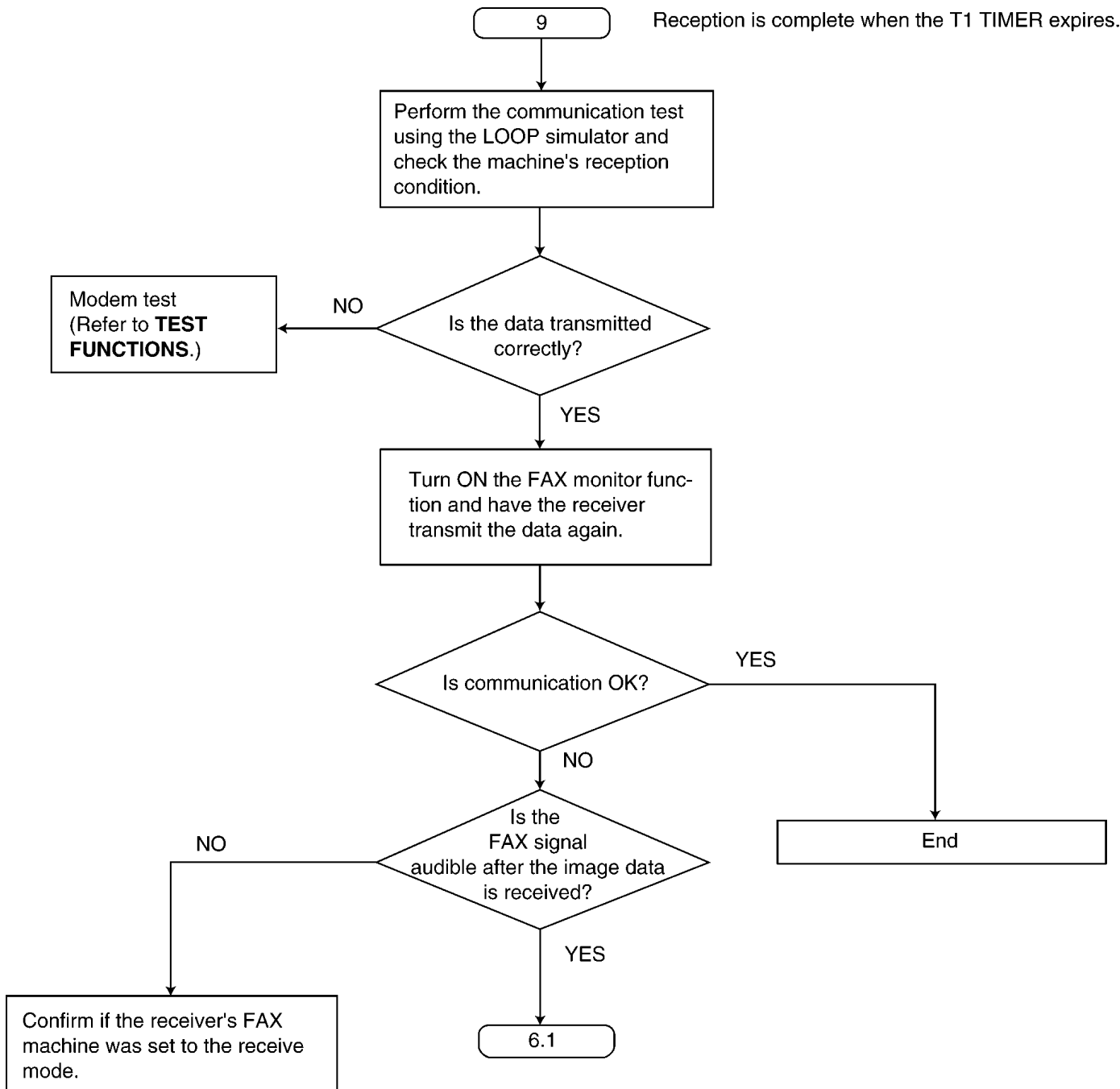

**CROSS REFERENCE:**  
**TEST FUNCTIONS (P.50)**

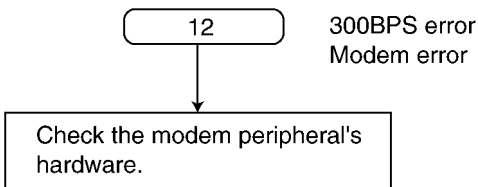
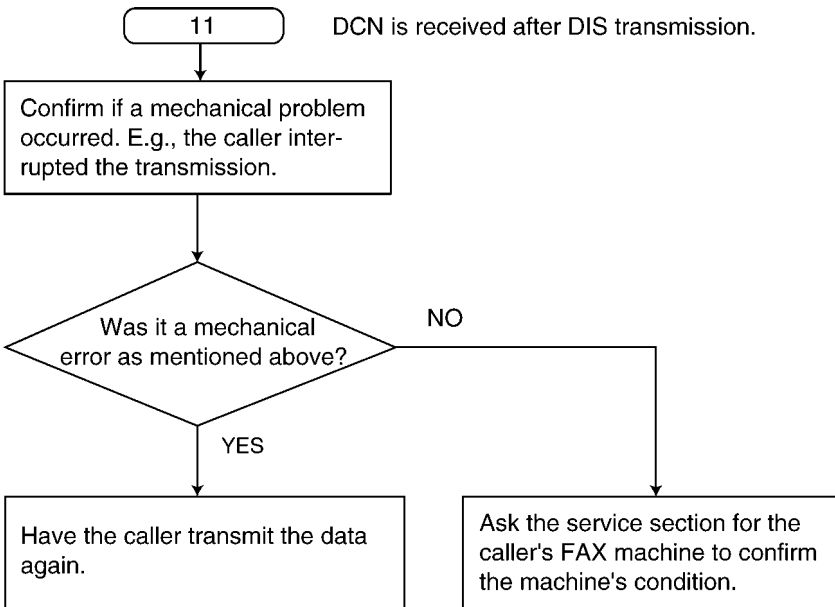
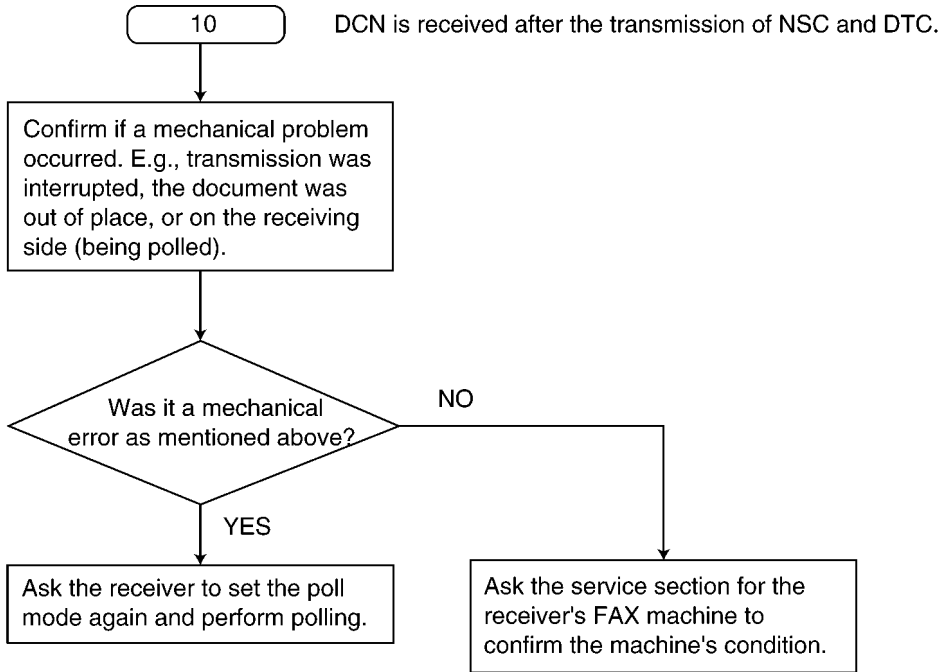

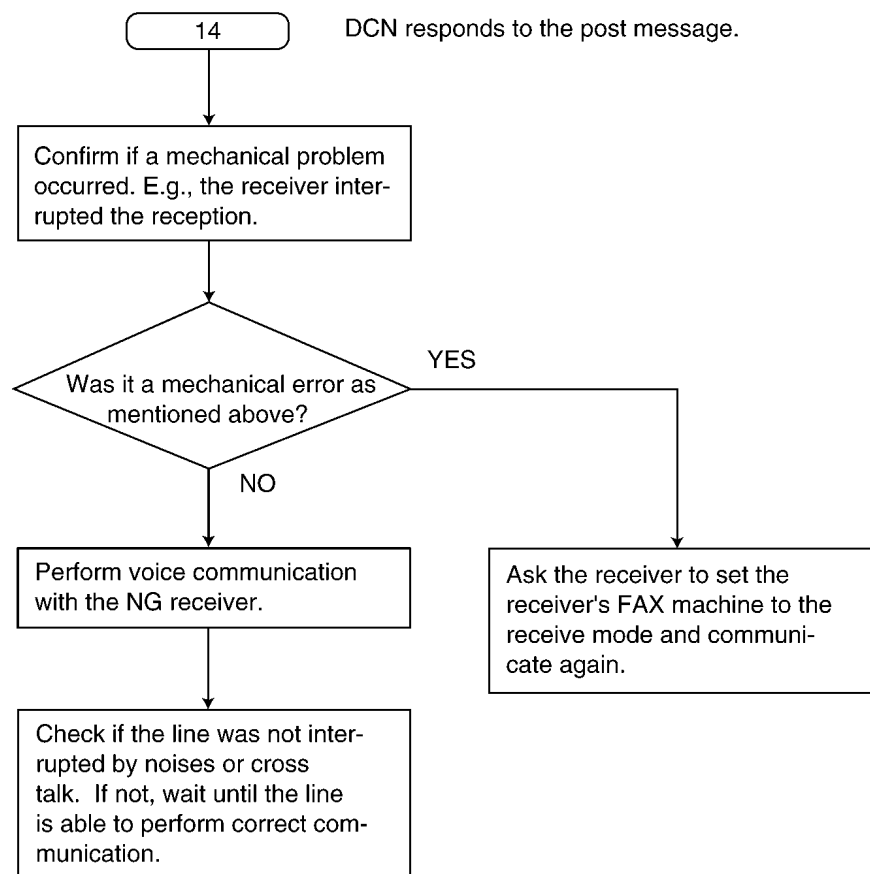
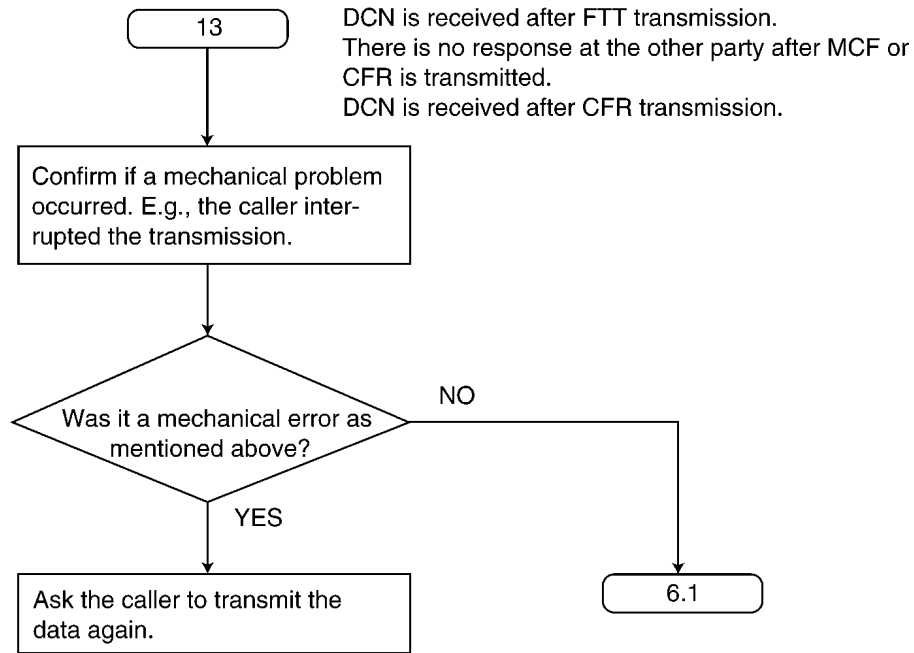

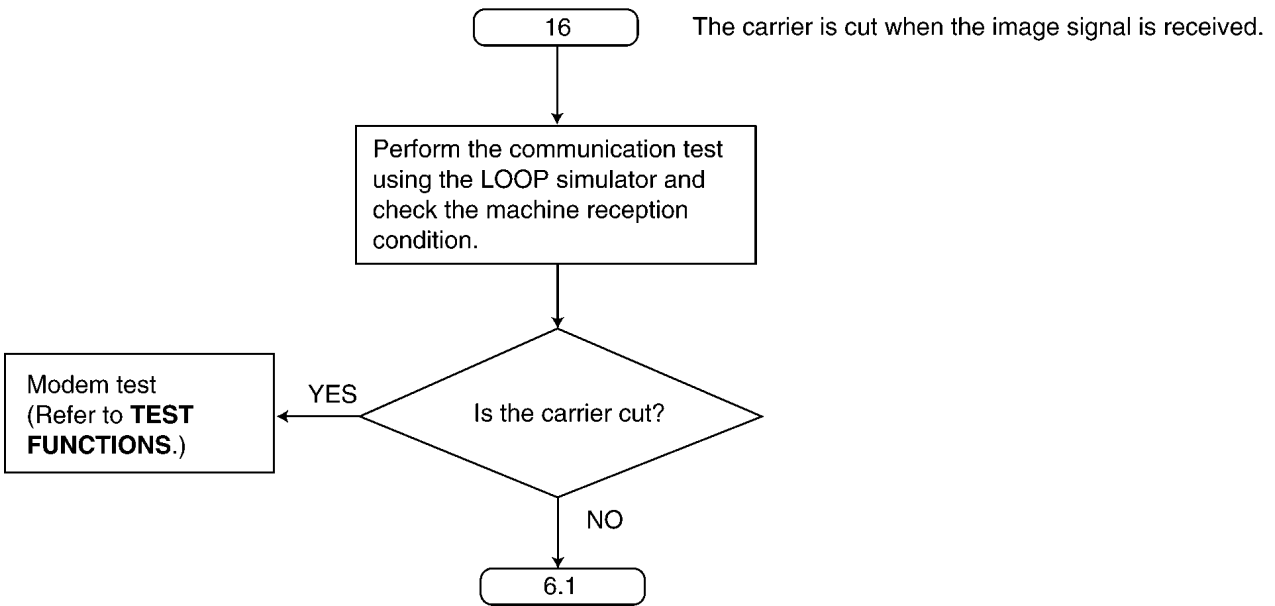
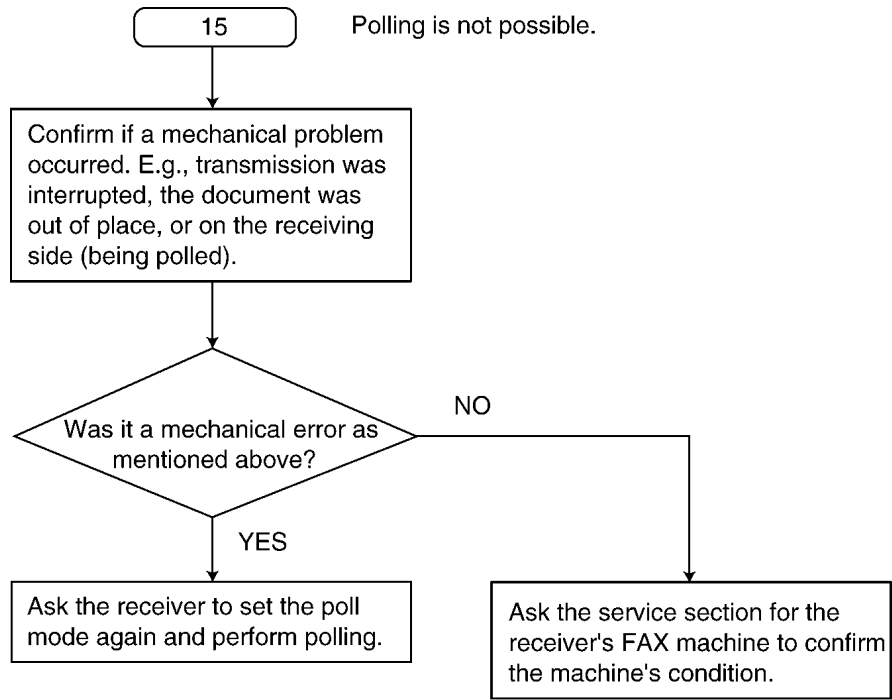

**CROSS REFERENCE:**  
**TEST FUNCTIONS (P.50)**

### 6.6.6. SPECIAL SERVICE JOURNAL REPORTS

Journal 2 and Journal 3 shown below, which are special journals giving the additional detailed information about the latest 35 communications, can be printed by Service Code 881 or 882. Remote printing function for the journal reports (JOURNAL, JOURNAL 2 and JOURNAL 3) is also available for service technicians. (Refer to **REMOTE PROGRAMMING (P.53)**.) The JOURNAL report only gives you basic information about a communication, but the other two journal reports provide different information on the same item (communication).

Jan. 23 2003 09:51AM  
YOUR LOGO :  
YOUR FAX NO:

NO.	OTHER FACSIMILE	START TIME	USAGE TIME	MODE	PAGES	RESULT	*CODE
01	3332222	Jan. 21 02:14PM	00'45	SND	01	OK	
02	9998765	Jan. 21 03:17PM	00'58	SND	02	OK	
03	John	Jan. 21 05:18PM	00'48	RCV	01	OK	
04	555556677	Jan. 22 10:35AM	02'45	RCV	03	COMMUNICATION ERROR	(46)

Jan. 23 2003 09:51AM

NO.	(1) RCV. MODE	(2) SPEED (CNT.)	(3) RESOLUTION	(4) RCV-TRIG. (CNT.)	(5) ERROR->MEMORY
01	TEL	9600BPS	STD.		
02	TEL	9600BPS	FINE		
03	FAX ONLY	7200BPS	STD.	FAX MOD	
04	FAX ONLY	9600BPS	STD.	CNG (0003)	

**NO RESPONSE DISAPPEARED ON JOURNAL**

NO.	(1) START TIME	(4) RCV MODE	(4) RCV-TRIG (CNT.)
	YOUR LOGO		
	YOUR FAX NUMBER		

Jan. 23 2003 09:51AM

NO.	(6) ENCODE	(7) MSLT	(8) EQM (RX)	(9) ERROR LINE (RX)	(10) MAKER CODE
01	MH	20msec	0000	00000	79
02	MH	20msec	0000	00000	00
03	MR	20msec	1200	00013	00
04	MR	20msec	0000	00000	00

**HOW TO READ JOURNAL REPORTS:**

**Example:**

1. Look at **NO. 01** in the JOURNAL. If you want to know about the details about that item, see **NO. 01** in the JOURNAL 2 and the JOURNAL 3. You can get the following information.

- \* MODE: Fax transmission
- \* RCV. MODE: TEL
- \* TX SPEED: 9.6 kbps
- \* RESOLUTION: standard
- \* ENCODE: MH
- \* MAKER CODE: 79

2. Look at **NO. 04** in the JOURNAL 2. CNG (0003) indicates that the CNG signal has been received three times since the purchase date.

For further details, see **JOURNAL 2 (P.94)** and **JOURNAL 3 (P.95)**.

### 6.6.6.1. JOURNAL 2

Refer to JOURNAL 2 in **PRINTOUT EXAMPLE**(P.95).

Journal 2 displays the additional detailed information about the last 35 communications.

#### Descriptions:

##### (1) RCV. MODE

Indicates which receive mode the unit was in when the unit received a fax message.

This information is also displayed when the unit transmitted a fax message.

##### (2) SPEED

Indicates the speed of the communication. If multiple pages are transmitted or received, it indicates the last page's communication speed. If there is a communication error, "?" is displayed.

##### (3) RESOLUTION

Indicates the resolution of the communication. If multiple pages are transmitted or received, it indicates the last page's resolution. If there is a communication error, "?" is displayed.

##### (4) RCV-TRIG. (CNT.)

Indicates the trigger that causes the unit to switch to the fax receive mode. The available options are listed in JOURNAL 2 in **PRINTOUT EXAMPLE**(P.95). The values in parentheses indicate how many times the trigger has been used. (For example, "0003" means three times.)

No.	Display	Function
1	FAX MODE	Means the unit received a fax message in the FAX mode.
2	MAN RCV	Means the unit received a fax message by manual operation.
3	FRN RCV	Means the unit received a fax message by friendly signal detection.
4	VOX	Means the unit detected silence or no voice.
5	RMT DTMF	Means the unit detected DTMF (Remote Fax activation code) entered remotely.
6	PAL DTMF	Means the unit detected DTMF (Remote Fax activation code) entered by a parallel connected telephone.
7	TURN-ON	Means the unit started to receive after 10 rings. (Remote Turn On: Service Code #573)
8	TIME OUT	Means the unit started to receive after Ring Time Out in the EXT-TAM or TEL/FAX mode.
9	IDENT	Means the unit detected Ring Detection.
10	CNG OGM	Means the unit detected the CNG while it was sending the Dummy Ring Back Tone in the TEL/FAX mode. OR Means the unit detected the CNG while it was sending the OGM in the ANS/FAX mode.
11	CNG ICM	Means the unit detected the CNG while it was recording the ICM in the ANS/FAX mode.

##### (5) ERROR→MEMORY

Indicates the reason why the unit received a fax message in memory.

If you look at No.11 in the JOURNAL 2 in **PRINTOUT EXAMPLE**(P.95), it shows the fax message was received in memory due to "PAPER OUT" error.

#### **NO RESPONSE DISAPPEARED ON JOURNAL**

The "**NO RESPONSE DISAPPEARED ON JOURNAL**" displays the information about the last 10 communications terminated by "No Response". (Some of the communications terminated by "No Response" were not displayed in the JOURNAL.)

When a fax transmission cannot be performed because the other party's unit is set to the TEL mode, "No response" will be printed.

### 6.6.6.2. JOURNAL 3

Refer to JOURNAL 3 in PRINTOUT EXAMPLE (P.95).

#### Description

##### (6) ENCODE

Compression Code: MH/MR/MMR

##### (7) MSLT

MSLT means Minimum Scan Line Time. Used only at the factory.

##### (8) EQM

EQM means Eye Quality Monitor. Used only at the factory.

##### (9) ERROR LINE (RX)

When an error occurs while receiving a fax, this shows the number of error lines.

##### (10) MAKER CODE

This shows a 2 digit code of the other party's fax machine brand.

0E: "KX" model

00: Unknown

79: "UF" model

19: "Xerox" model

### 6.6.6.3. PRINTOUT EXAMPLE

#### JOURNAL2

Mar. 25 2003 01:59PM

NO.	RCV. MODE	SPEED (CNT.)	RESOLUTION	RCV-TRIG. (CNT.)	ERROR->MEMORY
01	FAX ONLY	9600BPS	FINE.	FAX MOD	
02	FAX ONLY	9600BPS	STD.	FAX MOD	
03	FAX ONLY	9600BPS	FINE.		
04	FAX ONLY	9600BPS	FINE.	FAX MOD	
05	FAX ONLY	9600BPS	FINE.	FAX MOD	
06	FAX ONLY	9600BPS	FINE.	FAX MOD	
07	FAX ONLY	9600BPS	FINE.		
08	FAX ONLY	9600BPS	FINE.		
09	FAX ONLY	9600BPS	FINE.		
10	FAX ONLY	9600BPS	STD.	FAX MOD	
11	FAX ONLY	9600BPS	FINE.	FAX MOD	PAPER OUT
12	FAX ONLY	9600BPS	STD.	FAX MOD	
13	FAX ONLY	9600BPS	STD.		
14	FAX ONLY	?	?		
15	FAX ONLY	?	?		
16	FAX ONLY	?	?		
17	FAX ONLY	9600BPS	STD.		
18	FAX ONLY	9600BPS	FINE.	FAX MOD	
19	FAX ONLY	9600BPS	STD.	FAX MOD	
20	FAX ONLY	9600BPS	S-FINE.		
21	FAX ONLY	9600BPS	FINE.		
22	FAX ONLY	9600BPS	FINE.	FAX MOD	
23	FAX ONLY	?	?	FAX MOD	
24	FAX ONLY	9600BPS	STD.	FAX MOD	
25	FAX ONLY	9600BPS	STD.	FAX MOD	
26	FAX ONLY	9600BPS	FINE.	FAX MOD	
27	FAX ONLY	9600BPS	FINE.		
28	FAX ONLY	9600BPS	STD.	FAX MOD	
29	FAX ONLY	9600BPS	FINE.	FAX MOD	
30	FAX ONLY	9600BPS	S-FINE.	FAX MOD	
31	FAX ONLY	9600BPS	STD.	FAX MOD	
32	FAX ONLY	9600BPS	STD.	FAX MOD	
33	FAX ONLY	?	?	FAX MOD	
34	FAX ONLY	9600BPS	STD.	FAX MOD	
35	FAX ONLY	9600BPS	STD.	FAX MOD	

#### NO RESPONSE DISAPPEARED ON JOURNAL

NO.	START TIME	RCV MODE	RCV-TRIG. (CNT.)
-----	------------	----------	------------------

## JOURNAL3

Mar. 25 2003 01:58PM

NO.	ENCODE	MSLT	EGM(RX)	ERROR LINE(RX)	MAKER CODE
01	MR	10msec	007A	00000	0E
02	MR	20msec	016B	00000	00
03	MH	10msec	0000	00000	00
04	MR	20msec	019B	00003	00
05	MR	20msec	0156	00011	00
06	MR	20msec	0113	00000	00
07	MR	5msec	0000	00000	79
08	MR	5msec	0000	00000	79
09	MR	0msec	0000	00000	19
10	MR	20msec	0100	00000	00
11	MR	10msec	0073	00000	0E
12	MR	20msec	012B	00000	00
13	MH	20msec	0000	00000	79
14	MH	20msec	0000	00000	00
15	MH	20msec	0000	00000	00
16	MH	20msec	0000	00000	00
17	MR	5msec	0000	00000	79
18	MR	10msec	00AB	00004	0E
19	MR	20msec	0124	00000	00
20	MR	20msec	0000	00000	00
21	MR	20msec	0000	00000	00
22	MR	20msec	0135	00000	00
23	MR	20msec	0000	00000	00
24	MR	20msec	01BC	00000	00
25	MR	20msec	01AC	00000	00
26	MR	20msec	020F	00000	00
27	MR	10msec	0000	00000	0E
28	MR	20msec	01DF	00000	00
29	MR	20msec	01EA	00000	00
30	MR	20msec	00CD	00000	00
31	MR	20msec	02F8	00000	0E
32	MR	10msec	04F8	00000	0E
33	MR	10msec	0000	00000	00
34	MR	20msec	03B6	00000	0E
35	MH	20msec	00E0	00000	00



## 6.6.7. DIGITAL BOARD SECTION

When the unit fails to boot up the system, take the troubleshooting procedures very carefully. It may have a serious problem. The symptom: No response when the power is turned on. (No LCD display, and keys are not accepted.)

The first step is to check the power source. If there is no problem with the power supply unit, the problem may lie in the digital unit (main board).

As there are many potential causes in this case (ASIC, DRAM, etc.), it may be difficult to specify what you should check first. If a mistake is made in the order of checks, a normal part may be determined faulty, wasting both time and money.

Although the tendency is to regard the problem as a serious one (IC malfunction, etc.), usually most cases are caused by solder faults (poor contact due to a tunnel in the solder, signal short circuit due to solder waste).

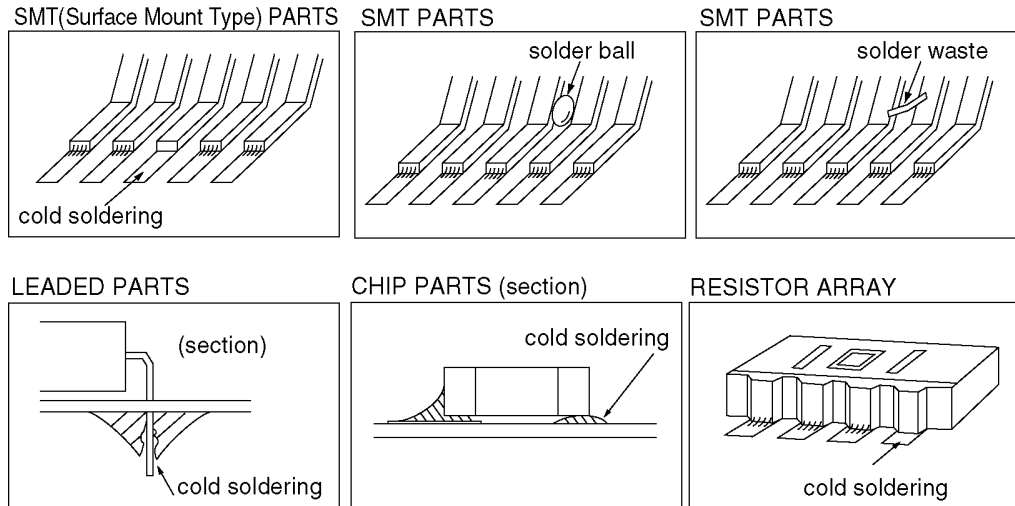

### Note:

1. Electrical continuity may have existed at the factory check, but a faulty contact occurred as a result of vibration, etc., during transport.
2. Solder waste remaining on the board may get caught under the IC during transport, causing a short circuit.

Before we begin mass production, several hundred trial units are produced at the plant, various tests are applied and any malfunctions are analyzed. (In past experiences, digital IC (especially DRAM and FLASH ROM) malfunctions are extremely rare after installation in the product.)

This may be repaired by replacing the IC, (DRAM etc.). However, the real cause may not have been an IC malfunction but a soldering fault instead.

Soldering faults difficult to detect with the naked eye are common, particularly for ASIC and RA (Resistor Array). But if you have an oscilloscope, you can easily determine the problem site or IC malfunction by checking the main signal lines.

Even if you don't have such a measuring instrument, by checking each main signal line and resoldering it, in many cases the problem will be resolved.

An explanation of the main signals (for booting up the unit) is presented below.

**Don't replace ICs or stop repairing until checking the signal lines.**

**An IC malfunction rarely occurs. (By understanding the necessary signals for booting up the unit, the "Not Boot up" display is not a serious problem.)**

### What are the main signals for booting up the unit?

The ASIC (IC501) controls all the other digital ICs. When the power is turned on, the ASIC retrieves the operation code stored in the FLASH ROM (IC523), then follows the instructions for controlling each IC. All ICs have some inner registers that are assigned to a certain address.

It is the address bus by which the ASIC designates the location inside each IC. And the data bus reads or writes the data in order to transmit the instructions from the ASIC to the ICs.

These signal lines are all controlled by voltages of 3.3V (H) or 0V (L).

Between the DRAM (IC503), Gate Array IC (IC520) signal lines are controlled by voltages of 5V (H) or 0V (L).

Digital Block Diagram

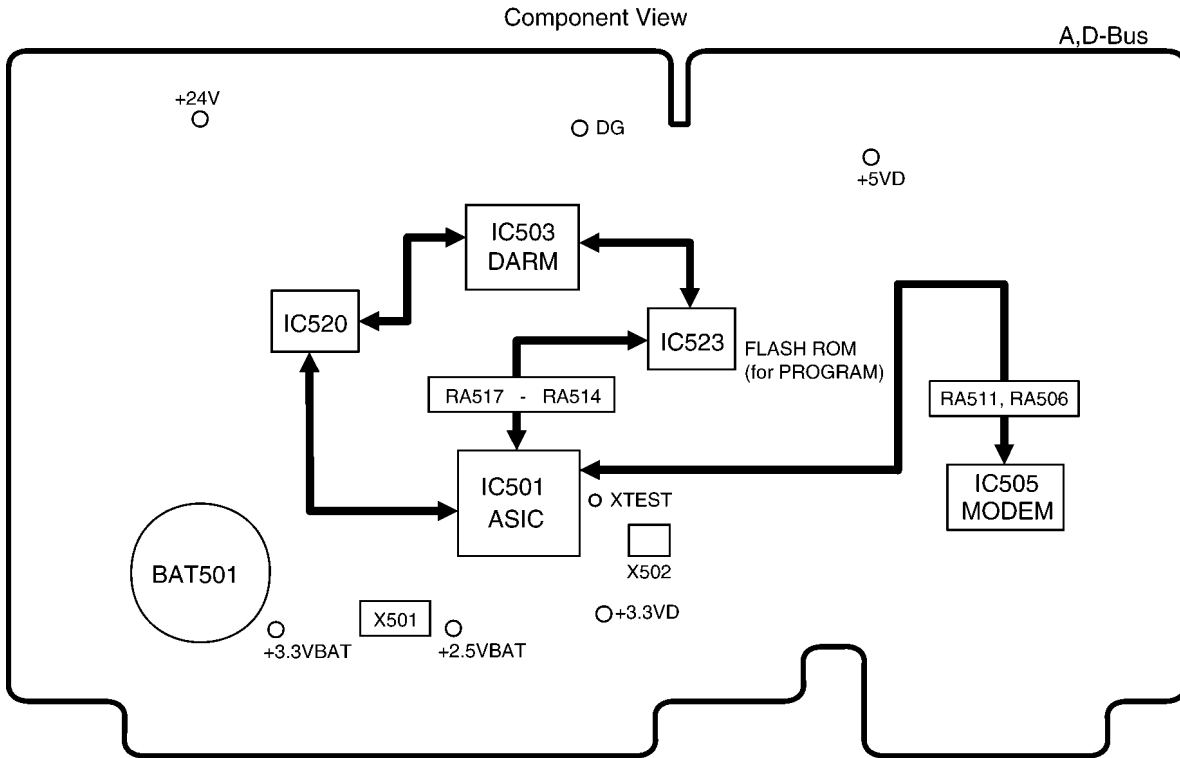

You also need to check the signal lines listed here [List 1] when the unit fails to boot up the system. Those signal lines should remain normal. Other signal lines are not directly related to that failure even if they have faults or troubles.

[List 1]

①	D0~D7	(Data Bus)
②	A0~A15	(Address Bus)
③	$\overline{RD}$	(Read Signal)
	$\overline{ROMCS}$	(ROM Select Signal)
	$\overline{WR}$	(Write Signal)
④	RBA0~RBA5	(Bank Address Signal)
⑤	$\overline{RAS}$	(DRAM Row Address Strobe Signal)
	$\overline{CAS}$	(DRAM Column Address Strobe Signal)
⑥	MDMCS	(Modem Select Signal)

As long as these signals remain normal, once the power is turned on, each IC can repeatedly output 3.3V (H) and 0V (L) (IC503 and IC520 output 5V(H) and 0V(L)). The following shows NG and normal wave patterns.

NG Wave pattern (Refer to NG EXAMPLE)

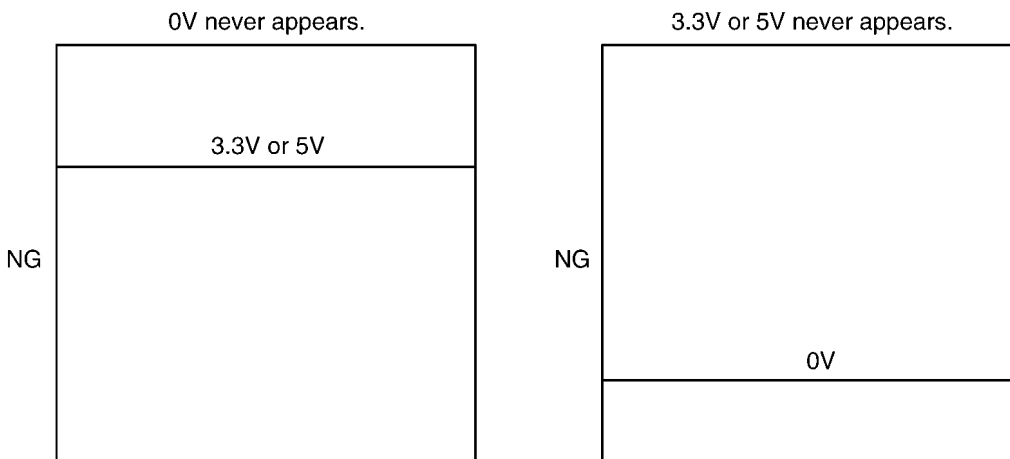

## Normal Wave Patterns

① D0~D7 200ns/div, 1V/div

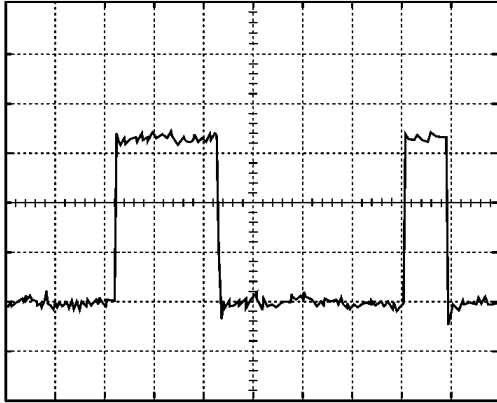

② A0~A5 200ns/div, 1V/div

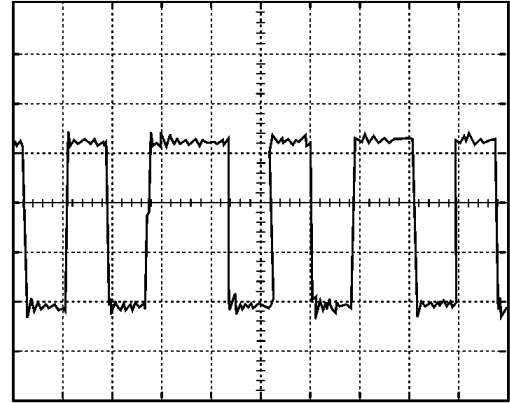

③  $\overline{RD}$  100ns/div, 1V/div

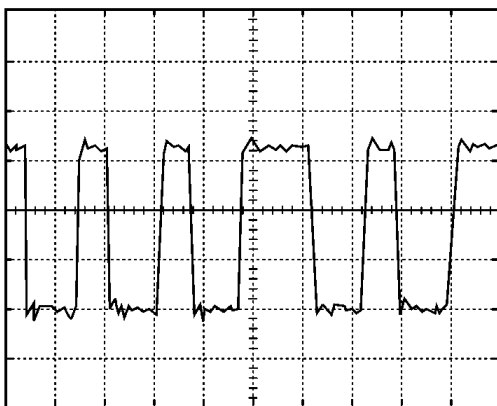

④  $\overline{ROMCS}$  400ns/div, 1V/div

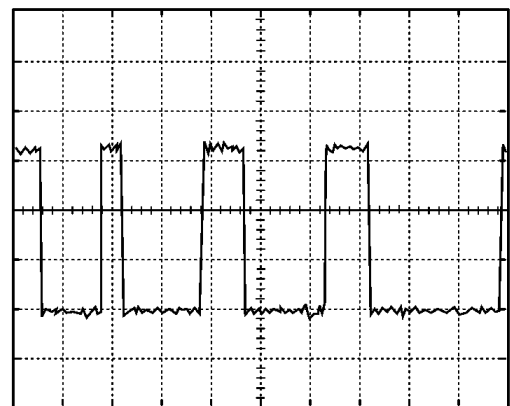

⑤  $\overline{RAS}$ ,  $\overline{CAS}$  100ns/div, 1V/div

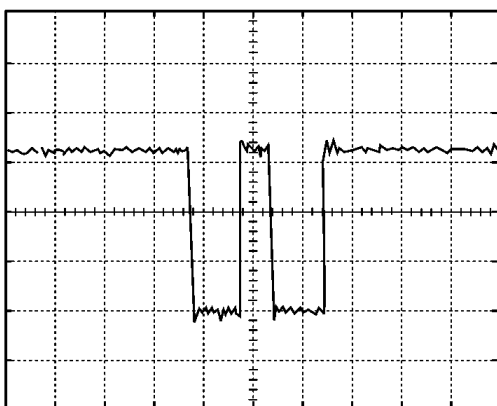

### Remarks:

When you use an oscilloscope to judge whether a signal to be tested is normal or NG, perform the signal check in exactly the same order as in [List 1]. (If the ASIC fails to access the FLASH ROM, the ASIC cannot access DRAM normally.)

The digital circuit actually operates according to the timing combinations of these signals. If the timing of these signals is even slightly delayed, the circuit will not work. Nor will it if the IC is defective and the output voltage level is not normal although the timing of these signals is accurate enough to meet the specifications. (Make sure that your oscilloscope is calibrated before starting a test.)

Therefore, it is imperative to confirm whether each IC outputs the signal at the correct level. (See the **I/O Pin No. Diagram**.) The signal level should be constantly output at between 3.3V (H) and 0V (L) as described earlier.

### Note:

Simply check the output level and make sure if the IC repeatedly outputs the signal at between 3.3V (H) and 0V (L).

I/O and Pin No. Diagram

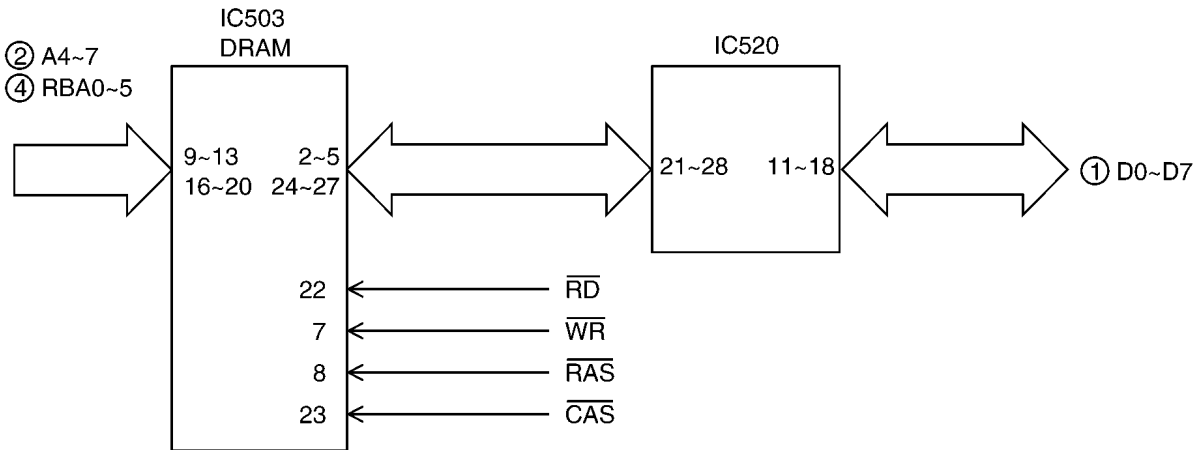
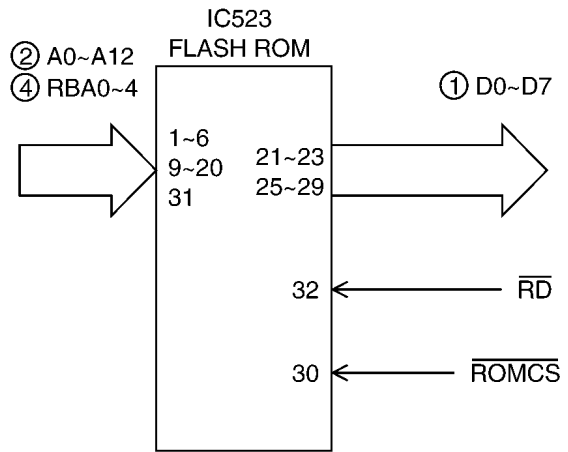
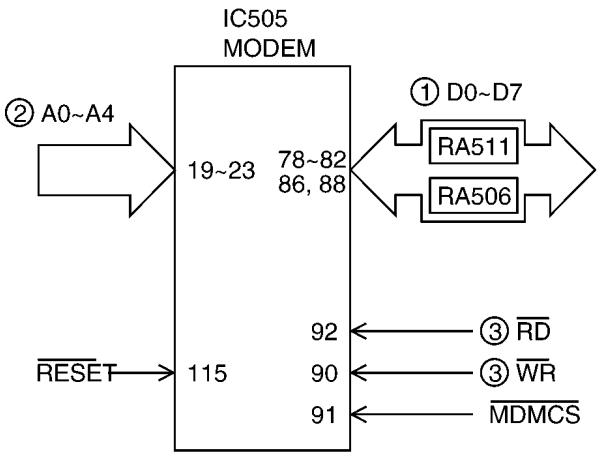
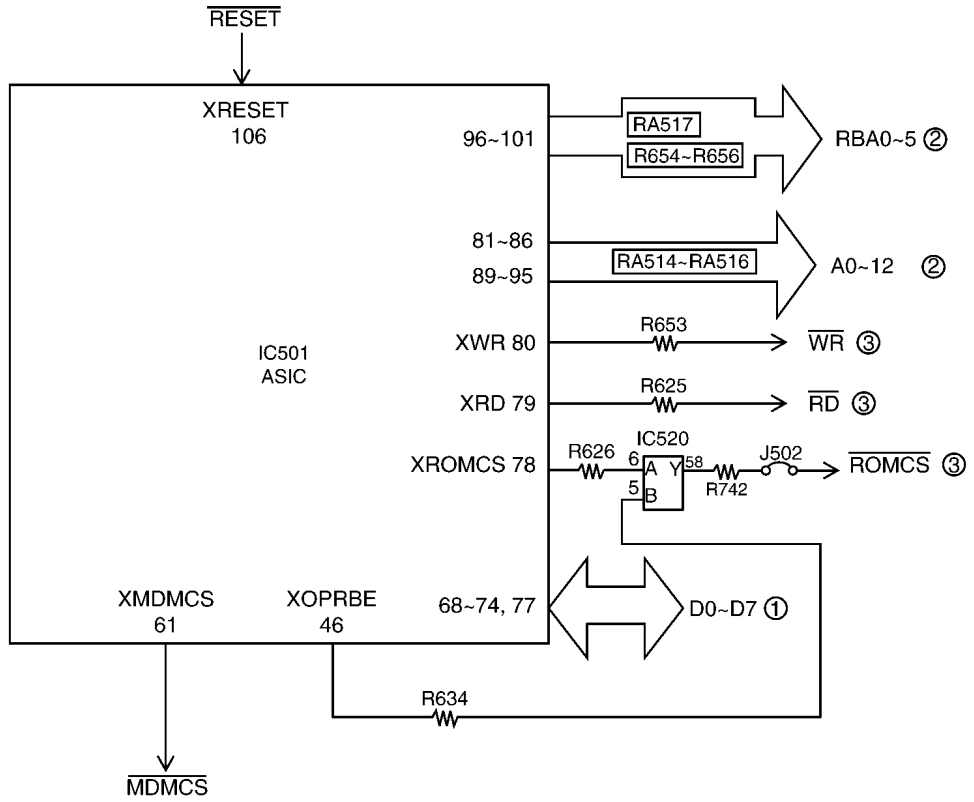

### 6.6.7.1. CHECK THE STATUS OF THE DIGITAL BOARD

Please check the status (voltage) of test lands **A** and **B**.  
The result may tell you a defective point.

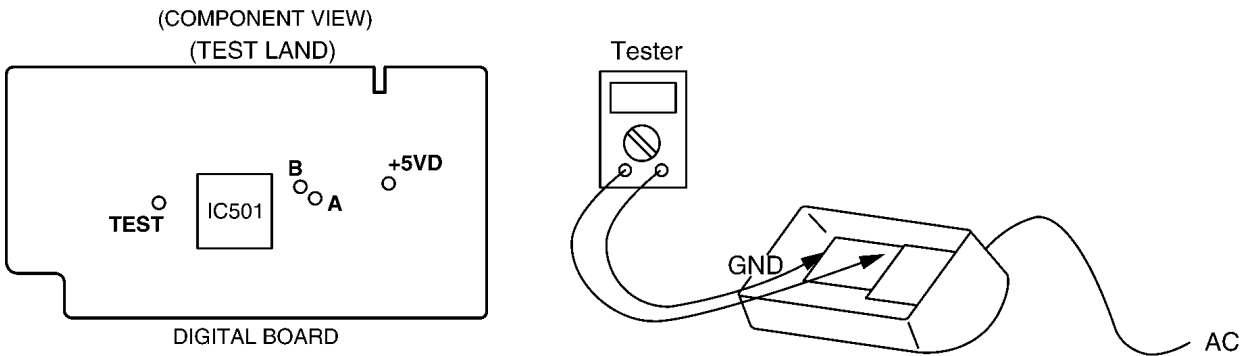

- Turn off the power supply.
- Short using a metallic object, such as tweezers, between the **TEST** point and **+5V** land, and turn on the AC power for a few seconds. And then remove a metallic object.
- Check the following voltages using an oscilloscope or tester.
- To cancel the status check mode, turn off the AC power.

Defective point	Check point voltage		Check items
	A	B	
RTC (IC501)	0V	0V	IC501( RTC is included in IC501)
DRAM (IC503)	0V	5V	IC503(8,23 pin), R549, R551, IC501(62, 63 pin), L507, RA509, RA510, IC520, R548, R550, R731
MODEM (IC505)	5V	0V	IC501(61 pin), IC505(90, 91, 92 pin), RA506, RA511, L510, L515, L519, L520, R564, C553, C554, Q525, Q526
ALL OK	5V	5V	

- This indicates that the Add/Data Bus, RAM, ROM, MODEM, and ASIC are all connected to the ASIC properly and that control from the ASIC is possible.

Please check the soldering and conduction of these components.  
If there is no problem, replace the ICs.

If you still have a problem with the digital board,  
please refer to **NG wave pattern**.

**CROSS REFERENCE:**

NG Wave pattern (Refer to NG EXAMPLE) (P.98)

### 6.6.7.2. INITIALIZING ERROR

After the power is turned on, the ASIC initializes and checks each IC.

The ROM, DRAM, and modem are checked.

If initialization fails for the ICs, the system will not boot up.

In this case, please find the cause as follows.

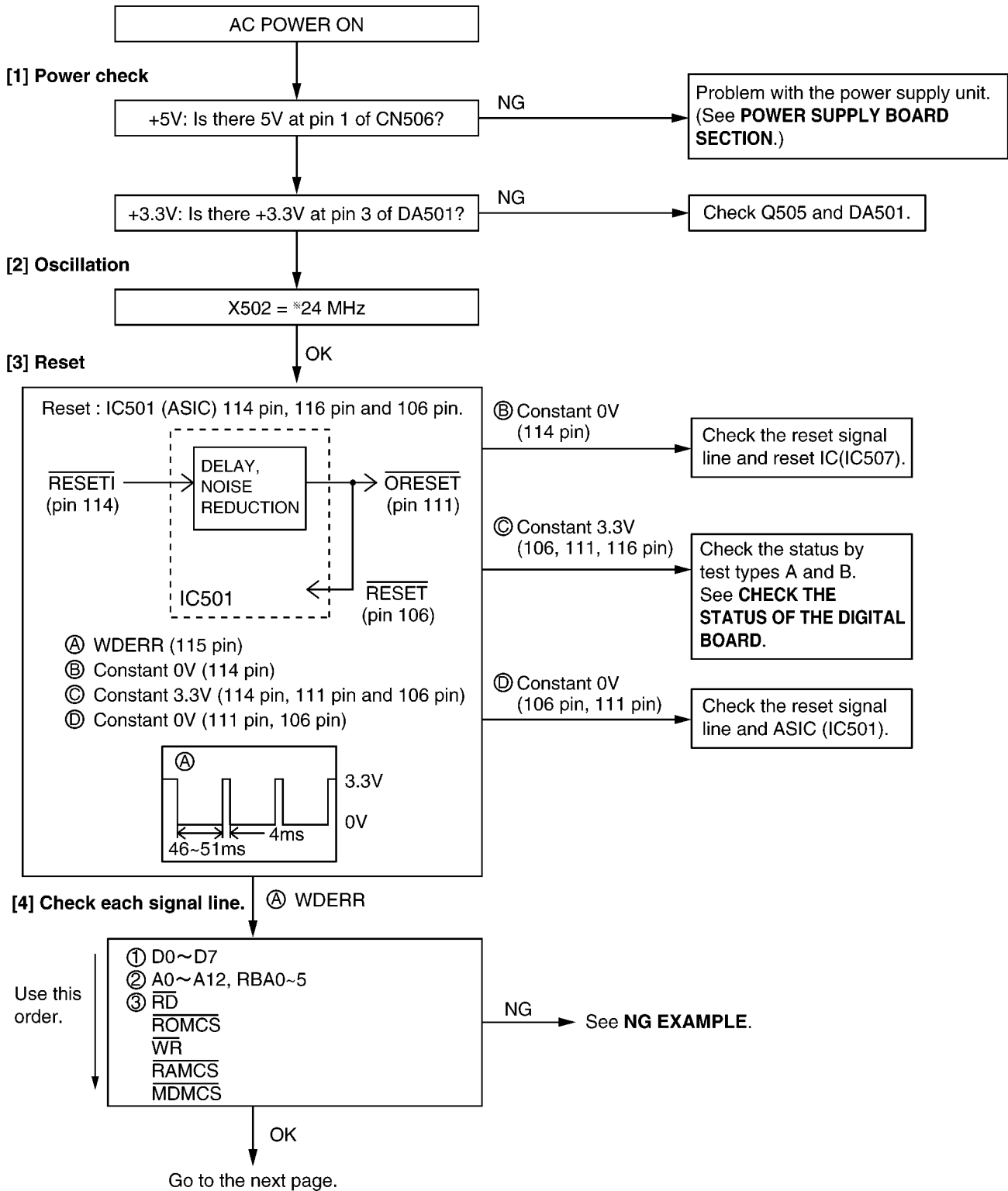

**CROSS REFERENCE:**

**NG EXAMPLE** (P.104)

**CHECK THE STATUS OF THE DIGITAL BOARD** (P.101)

**POWER SUPPLY BOARD SECTION** (P.108)

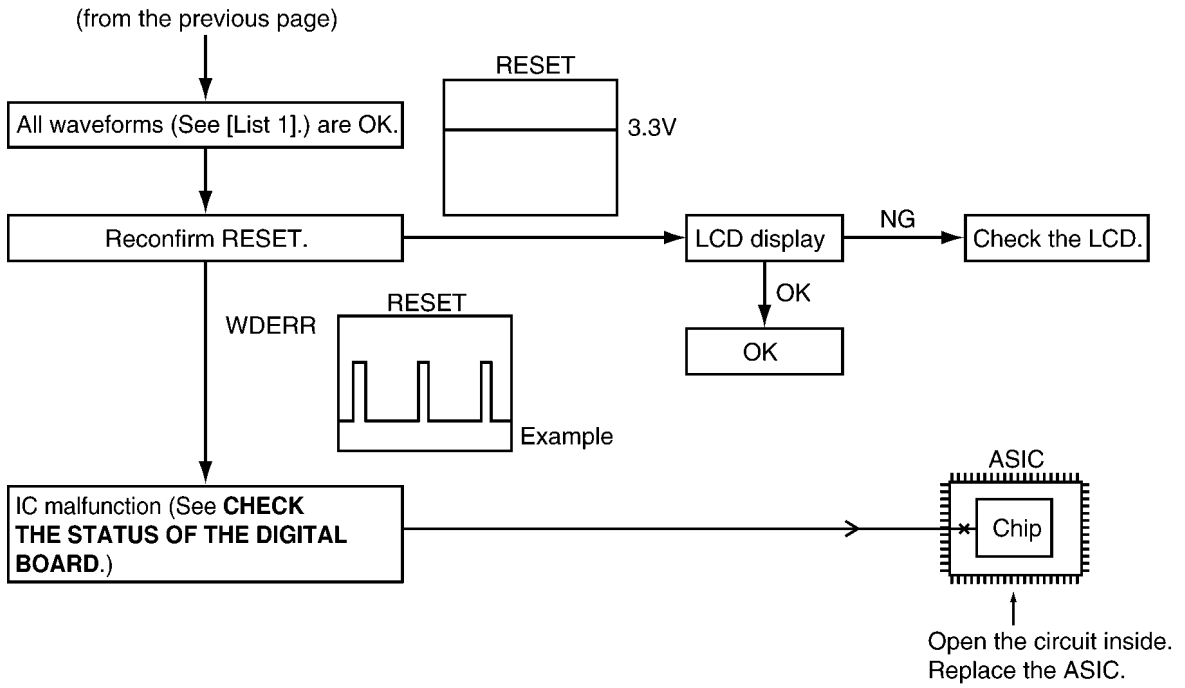

**CROSS REFERENCE:**

**CHECK THE STATUS OF THE DIGITAL BOARD (P.101)**

**Other NG example while the power is ON and the LCD displays the following.**

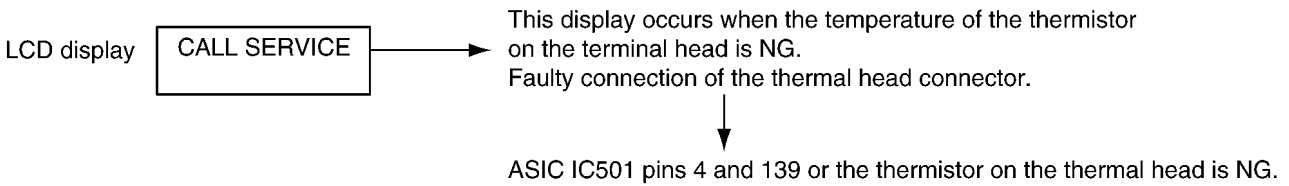

### 6.6.7.3. NG EXAMPLE

1.

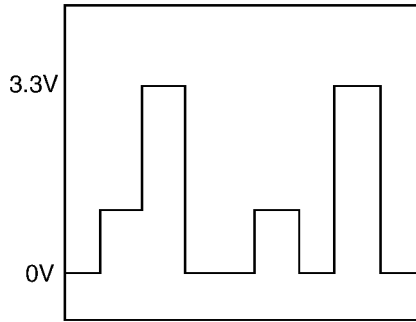

Short circuit from the adjacent signal wires.  
Check for a short circuit in the RA and IC leads and the signal wire at the through hole.

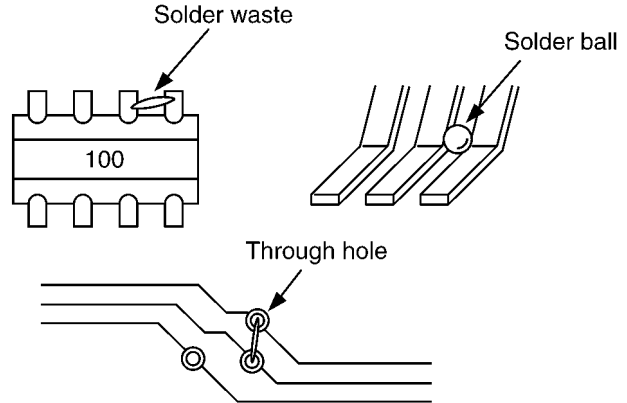

2.

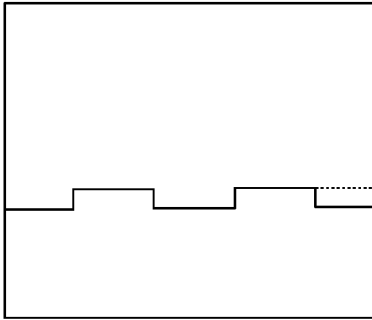

Short between the signal line and GND.

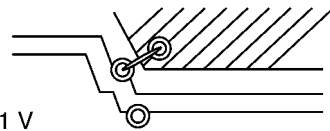

Approx. 0 or 1 V

OR IC malfunction

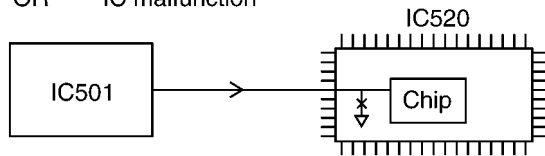

3.

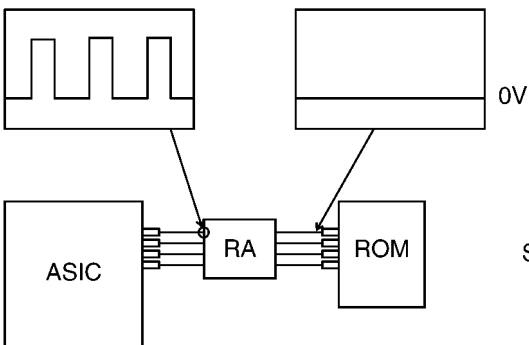

Solder fault on RA.



## 6.6.8. ANALOG BOARD SECTION

This chapter provides the testing procedures required for the analog parts. A signal route to be tested is determined depending upon purposes. For example, the handset TX route begins at the handset microphone and the signal is output to the telephone line. The signal mainly flowing on this route is analog. You can trace the signal with an oscilloscope. The signal flow on each route is shown in the Check Sheet here. If you find a specific problem in the unit, for example if you cannot communicate with the H/S, trace that signal route locally with the following Check Sheet and locate the faulty point.

### 6.6.8.1. CHECK SHEET

(SYMPTOM) ITEMS TO CHECK	IN	signal ROUTE	OUT
MONITOR		TEL LINE→T101→C112→R112→IC101(2-1)→CN101(4)→{CN517(4)→IC509(9-8)→C570→R575→Q508(B-C)→C601→R566→IC501(32-31)→C579→R587→IC511(6-7)→CN517(16)}→CN101(16)→C172→R172→IC102(4-5, 8)→CN105(1, 2)→SPEAKER	
Handset TX		HS MIC→CN104(4)→L110→C139→R139→IC101(6)→IC101(7)→CN101(6)→{CN517(6)→R593→CN104(1)→L107→C140→R125→IC101(5)}→C586→R594→C581→R583→IC511(2-1)→CN517(3)}→CN101(3)→C125→R121→T101→TEL LINE	
Handset RX		TEL LINE→T101→C112→R112→IC101(2-1)→CN101(4)→{CN517(4)→IC509(9-8)→C570→R575→Q508(B-C)→C601→R566→IC501(32-31)→C579→R587→IC511(6-7)→R584→C576→IC509(4-3)→CN517(7)}→CN101(7)→JJ103→R134→Q103(B-E)→C132→R149→L108→CN104(3)→Handset SP	
FAX TX DTMF for TEL Line		{IC505(69)→IC509(1-2)→C571→R579→IC511(2-1)→CN517(3)}→CN101(3)→C125→R121→T101→TEL LINE	
FAX RX		TEL LINE→T101→C112→R112→IC101(2-1)→CN101(4)→{CN517(4)→C573→R576→IC505(60)	
DTMF MONITOR	HS	IC505(72)→C567→R571→Q508(B-C)→C601→R566→IC501(32-31)→C579→IC511(5-7)→R586→C576→IC509(4-3)→CN501(10)}→CN101(10)→R132→Q102(B-E)→C126→L108→CN104(3)→Handset SP	
	SP	{IC505(72)→C670→R571→Q508(B-C)→C601→R566→IC501(32-31)→C579→IC511(6-7)→CN517(16)}→CN101(16)→C172→R172→IC102(4-5, 8)→CN105(1, 2)→SPEAKER	
CNG / DTMF / VOX Detection		TEL LINE→T101→R120→C113→Q101(C-E)→C114→R114→IC101(2-1)→CN101(4)→{CN517(4)→C573→R576→IC505(60)	
Caller ID		TEL LINE→T101→R120→C113→Q101(C-E)→C114→R114→IC101(2-1)→CN101(4)→{CN517(4)→C577→R582→IC505(62)}	
Ringing / Alarm / Beep / Key Tones		IC501(29)→R568→Q511(E-C)→C568→R572→Q508(B-C)→C601→R566→IC501(32-31)→C579→IC511(6-7)→CN517(16)}→CN101(16)→C172→R172→IC102(4-5, 8)→CN105(1, 2)→SPEAKER	

**Note:**

{ }: Inside the digital board

### 6.6.8.2. DEFECTIVE ITS (Integrated Telephone System) SECTION

#### 1. No handset transmission / reception and no monitor reception

Perform a signal test in the **ITS or the NCU section** and locate a defective point (where the signal disappears) on each route between the handset microphone and telephone line (sending), or between the telephone line and the handset speaker (receiving), or between the microphone and the telephone line (sending), or between the telephone line and the speaker (receiving). Check the components at that point. **CHECK SHEET (P.105)** is useful for this investigation.

#### 2. No pulse dialing

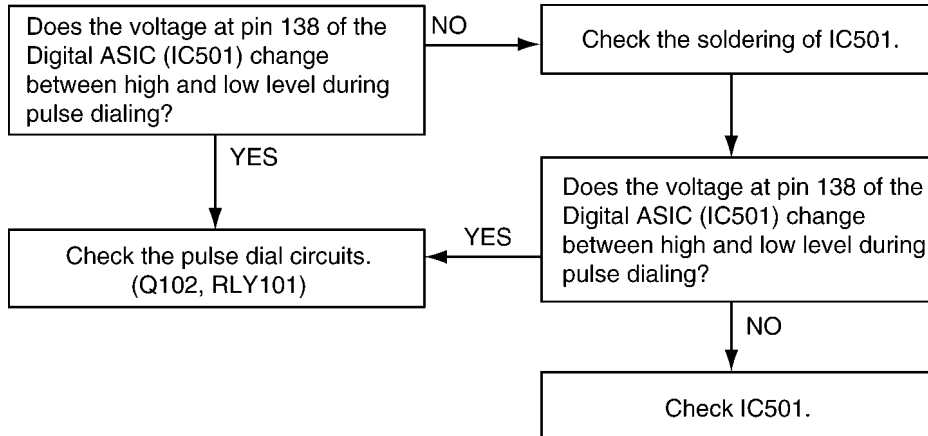

#### 3. No ring tone (or No bell)

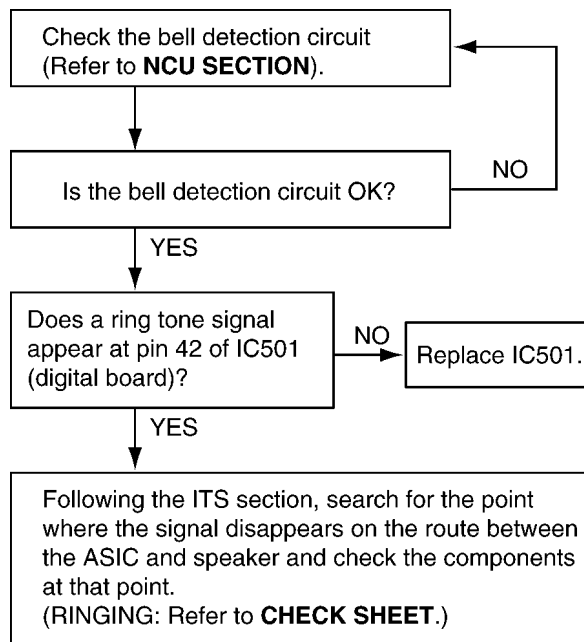

**CROSS REFERENCE:**  
**CHECK SHEET (P.105)**  
**NCU SECTION (P.147)**

4. No tone dialing

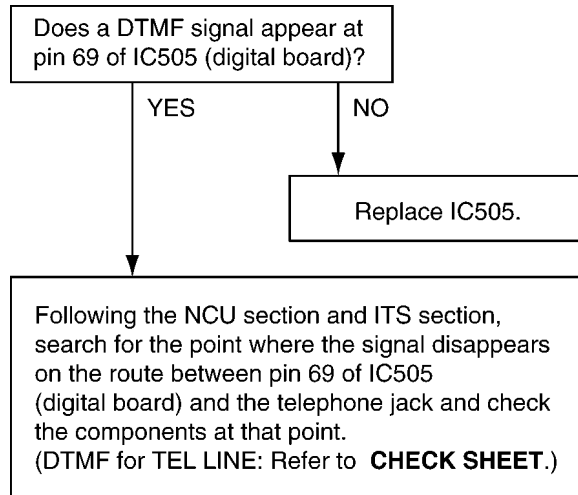

**CROSS REFERENCE:**  
**CHECK SHEET (P.105)**

6.6.8.3. DETECTIVE TAM INTERFACE SECTION

1. The FAX turns on, but does not arrive through TAM.

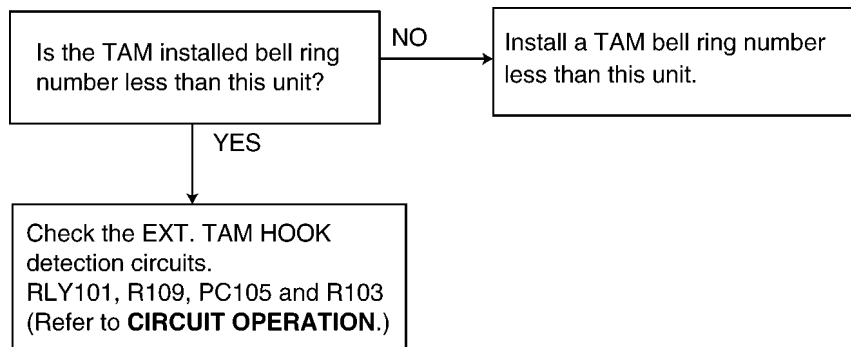

**CROSS REFERENCE:**  
**CIRCUIT OPERATION (P.153)**

2. A FAX is received, but won't switch from TAM to FAX.

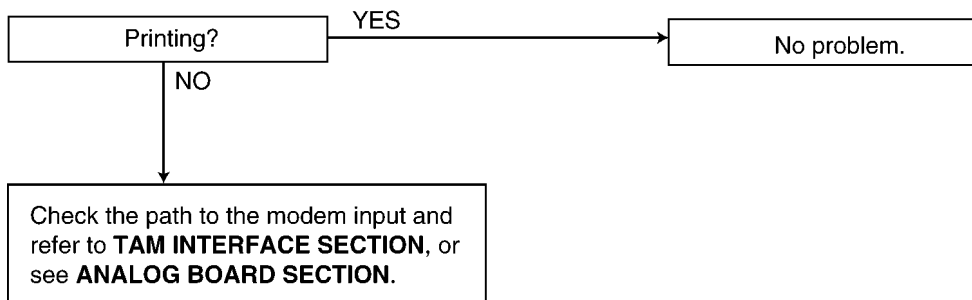

**CROSS REFERENCE:**  
**ANALOG BOARD SECTION (P.105)**  
**TAM INTERFACE SECTION (P.152)**

## 6.6.9. POWER SUPPLY BOARD SECTION

### 6.6.9.1. KEY COMPONENTS FOR TROUBLESHOOTING

Check the following parts first: F101, D101-D104, C106, Q101, PC101 and IC101.

This comes from our experience with experimental tests. For example: power supply and lightning surge voltage test, withstanding voltage test, intentional short circuit test, etc.

**Caution:**

If you find a melted fuse in the unit, do not turn on the power until you locate and repair the faulty parts (except for the fuse); otherwise the fuse will melt again and you cannot pinpoint the faulty point.

In most cases, the symptom is that nothing is output. It is more likely that the fault is in the primary side rather than the secondary side. Check the primary side first.

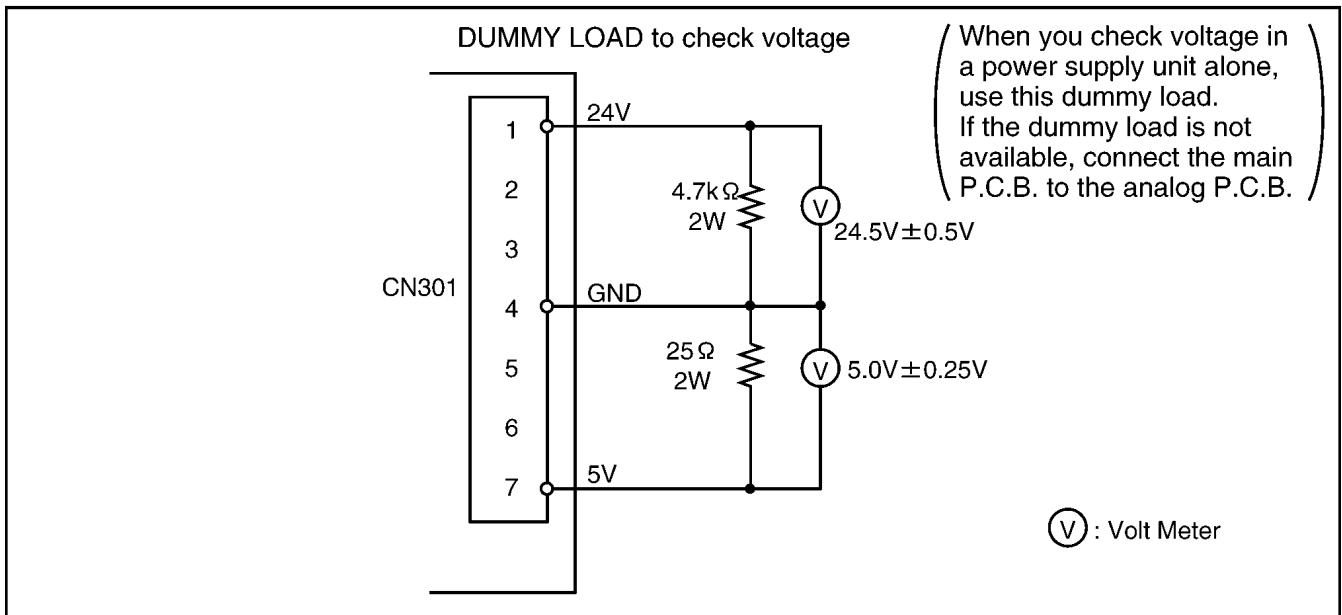
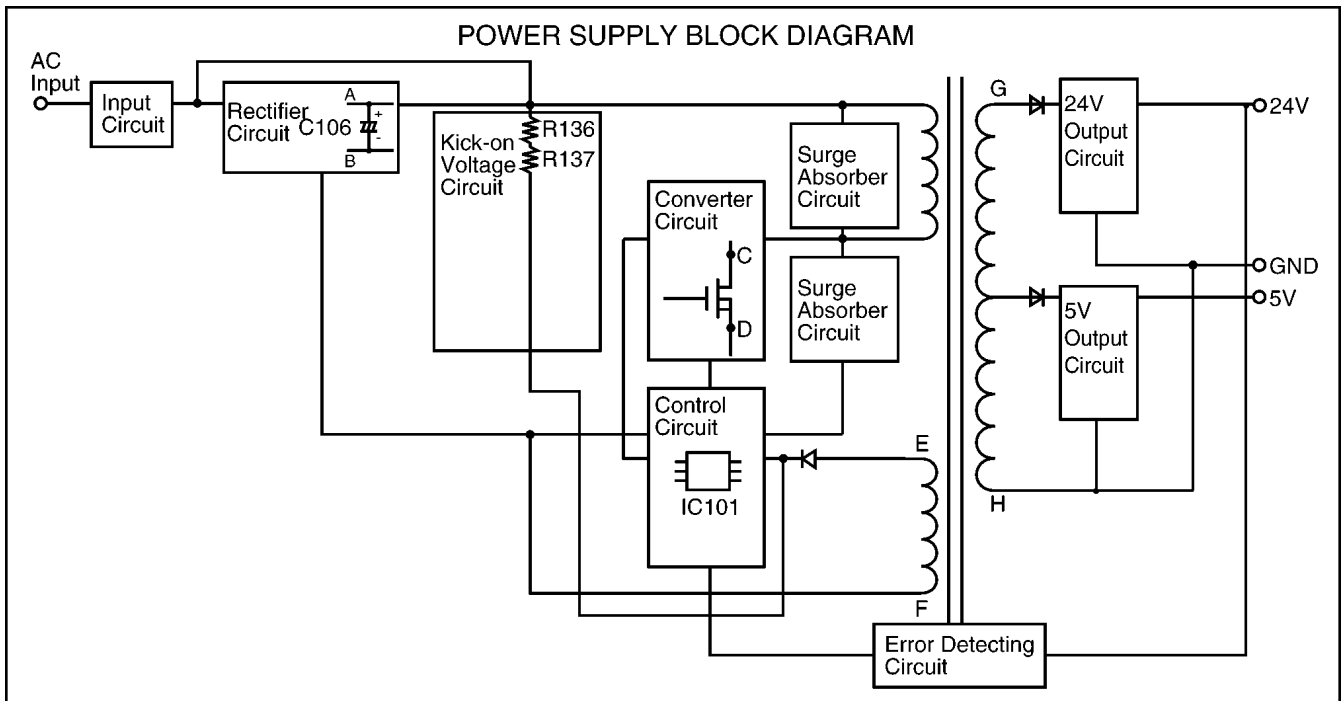

### 6.6.9.2. TROUBLESHOOTING FLOW CHART

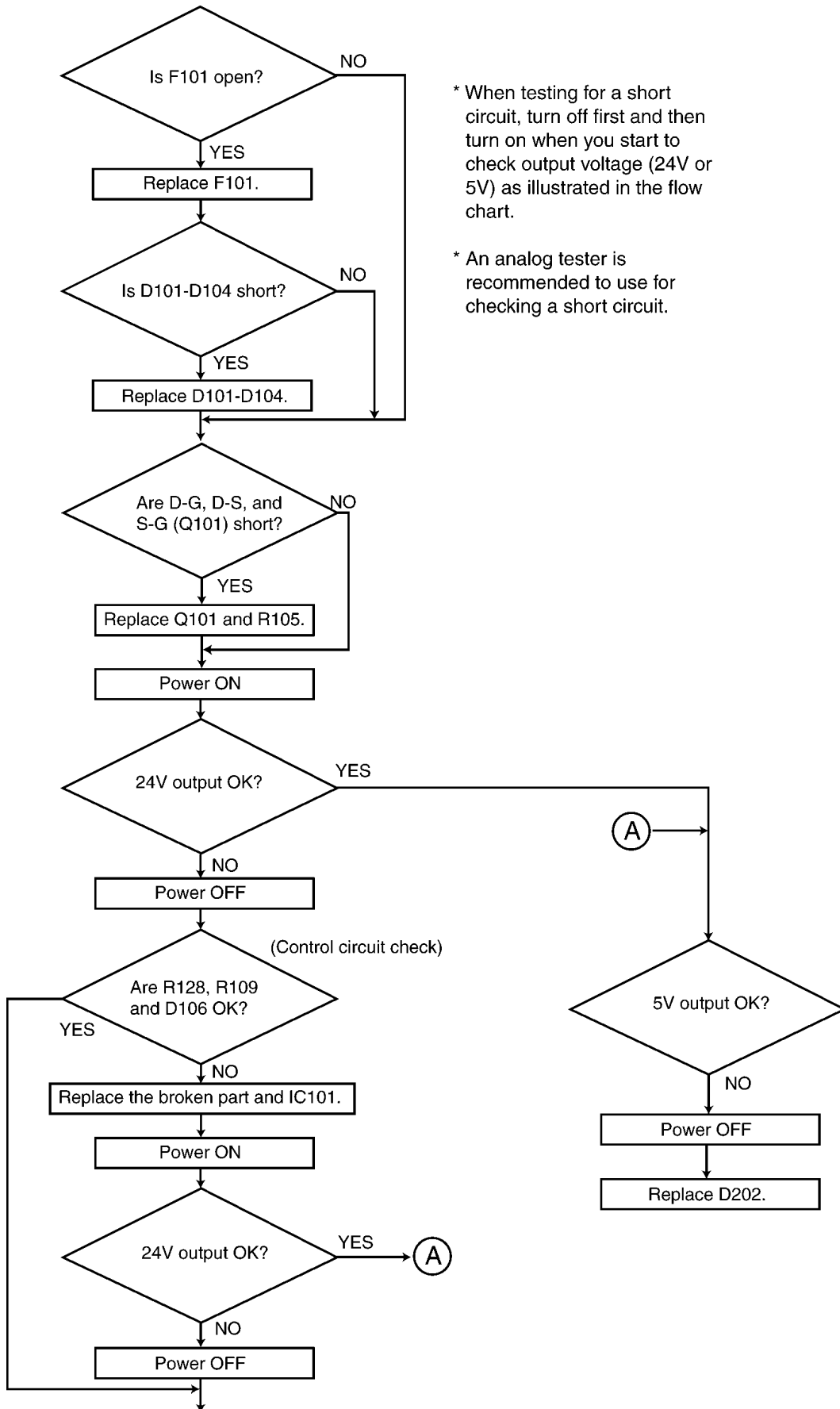

\* When testing for a short circuit, turn off first and then turn on when you start to check output voltage (24V or 5V) as illustrated in the flow chart.

\* An analog tester is recommended to use for checking a short circuit.

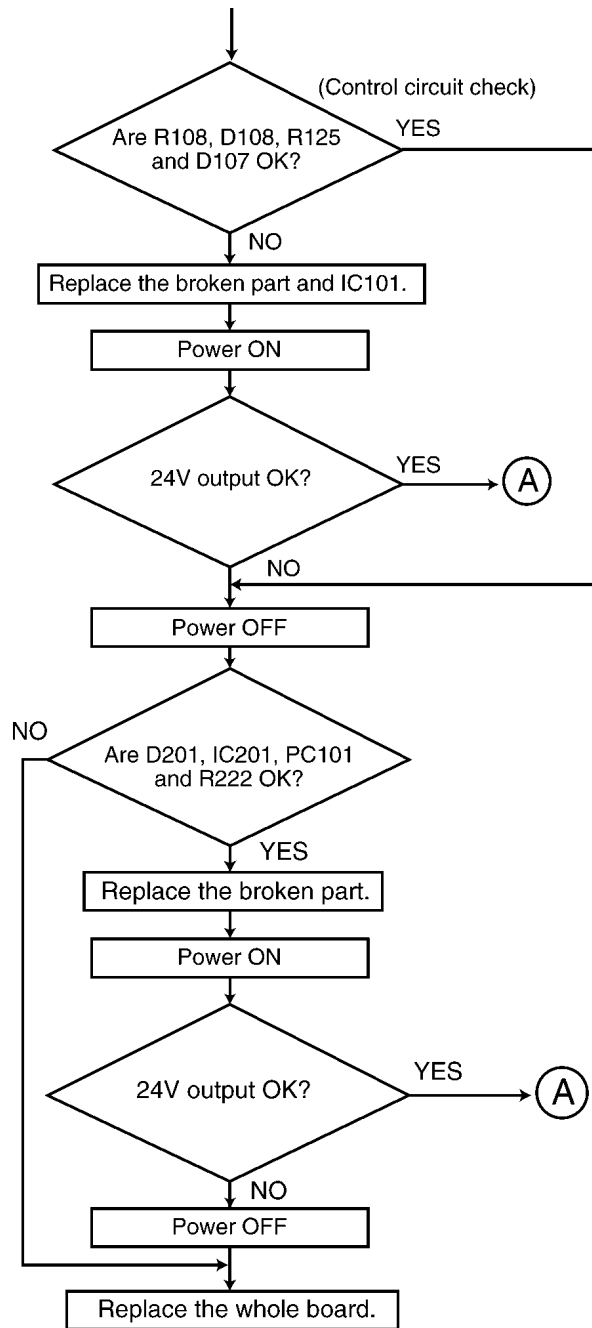

### 6.6.9.3. BROKEN PARTS REPAIR DETAILS

(D101, D102, D103, D104)

Check for a short-circuit in terminal 4. If D101, D102, D103 and D104 are short-circuits, F101 will melt (open). In this case, replace all of the parts (D101, D102, D103, D104, F101).

(Q101)

The worst case of Q101 is a short-circuit between the Drain and Gate because damage expands to the peripheral circuit of Q101. This is due to a very high voltage through the Gate circuit which is composed of R128, R109, D106 and IC101. You should change all of the parts listed as follows.

F101, Q101, R128, R109, D106, IC101

(D201)

If D201 is broken, the oscillation circuit in the power supply cannot operate. Check it with an electric tester.

## 6.6.10. OPERATION PANEL SECTION

### 6.6.10.1. NO KEY OPERATION

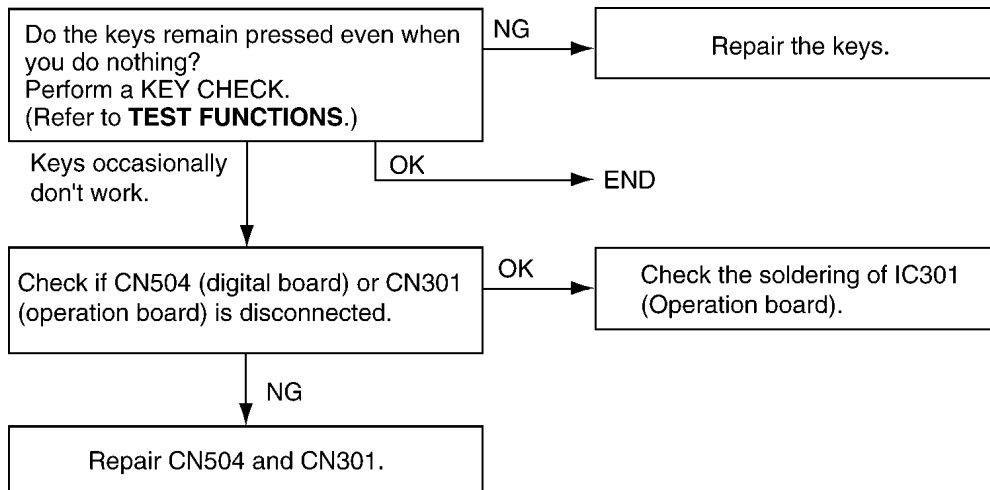

#### CROSS REFERENCE:

TEST FUNCTIONS (P.50)

### 6.6.10.2. NO LCD INDICATION

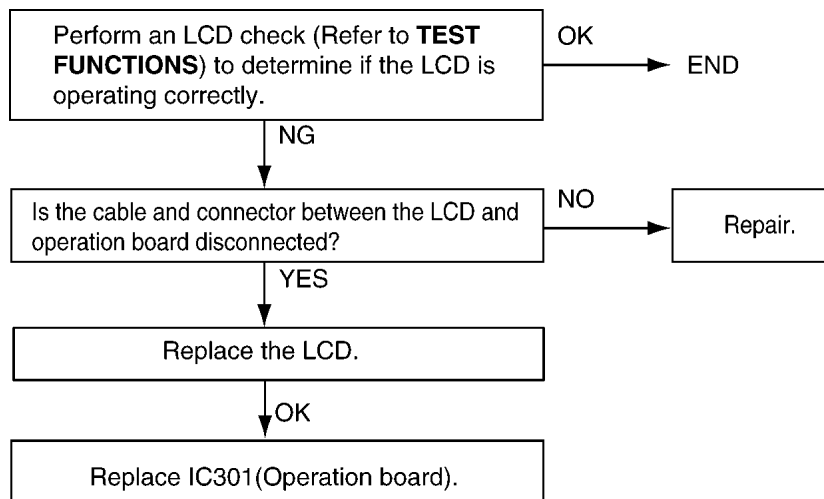

#### CROSS REFERENCE:

TEST FUNCTIONS (P.50)

### 6.6.11. SENSOR SECTION

Refer to **SENSORS AND SWITCHES**(P.135) for the circuit descriptions.

The Test Function makes the sensor circuit check easier. (Refer to **TEST FUNCTIONS**(P.50).)

For example, as for "COVER OPEN SENSOR", "CO" is turned ON/OFF on the display when you open or close the front cover. Also, document sensor, read position sensor, recording paper sensor and jam sensor are turned ON/OFF by the copy operation. Therefore, each sensor can be checked for proper mechanical operation.

As for the electric check, check whether each voltage is right or not with following flowchart turning each sensor lever ON/OFF manually.

#### 6.6.11.1. CHECK THE DOCUMENT TOP SW (SW352)....."REMOVE DOCUMENT"

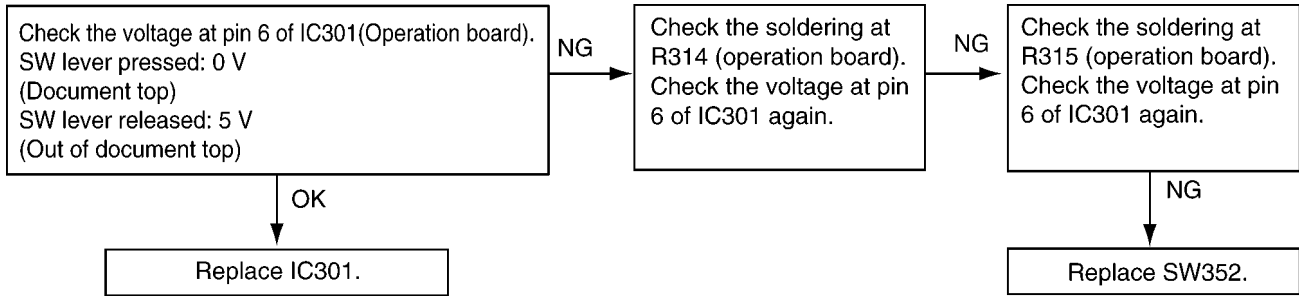

#### 6.6.11.2. CHECK THE DOCUMENT SET SW (SW353)....."CHECK DOCUMENT"

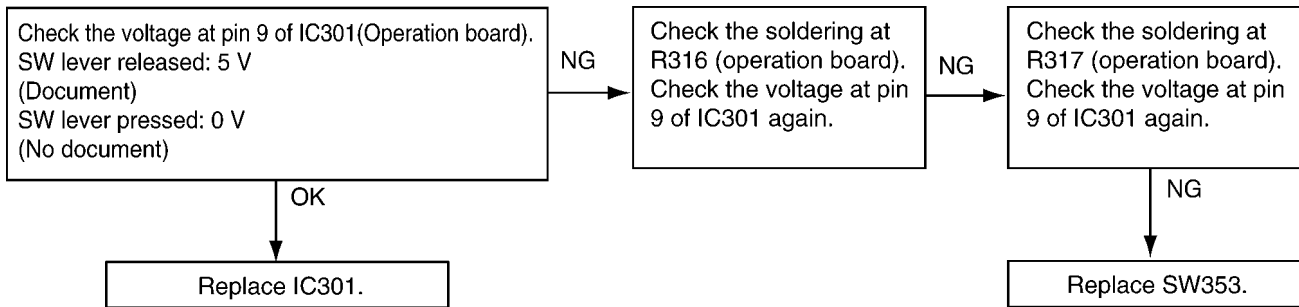

#### 6.6.11.3. CHECK THE COVER OPEN (SW502)....."COVER OPEN "

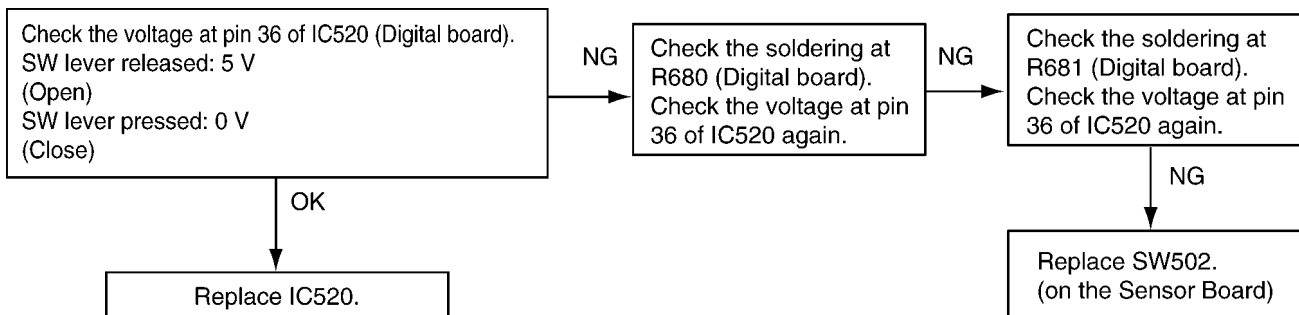



**6.6.11.4. CHECK THE HOOK SWITCH (SW101)**

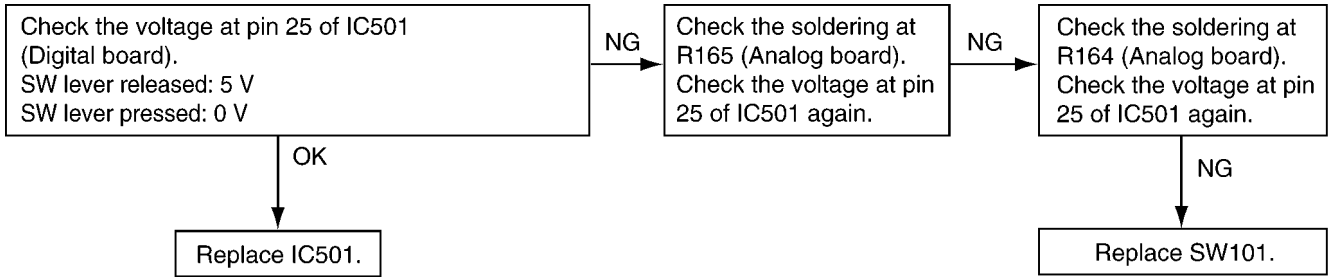

**6.6.11.5. CHECK THE PAPER TOP SENSER (PS501)....."PAPER JAMMED"**

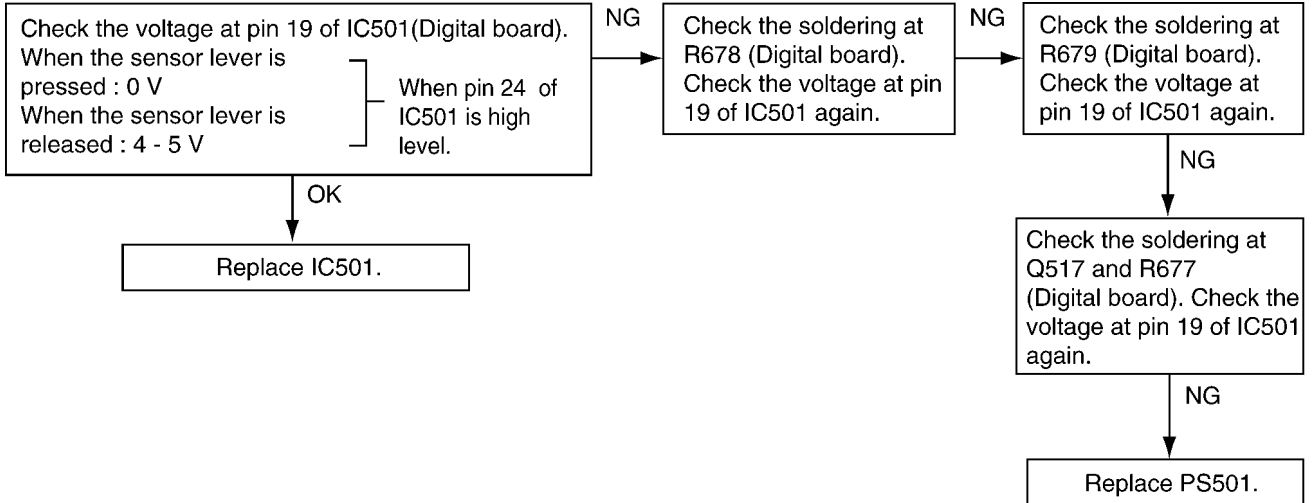

**6.6.11.6. CHECK THE FILM SENSER (SW501)....."CHECK FILM SLACK"**

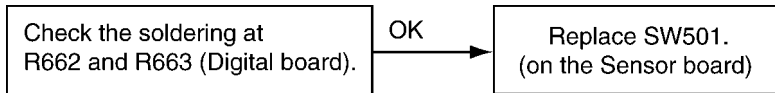

### 6.6.12. CIS (Contact Image Sensor) SECTION

Refer to **SCANNING BLOCK**(P.132).

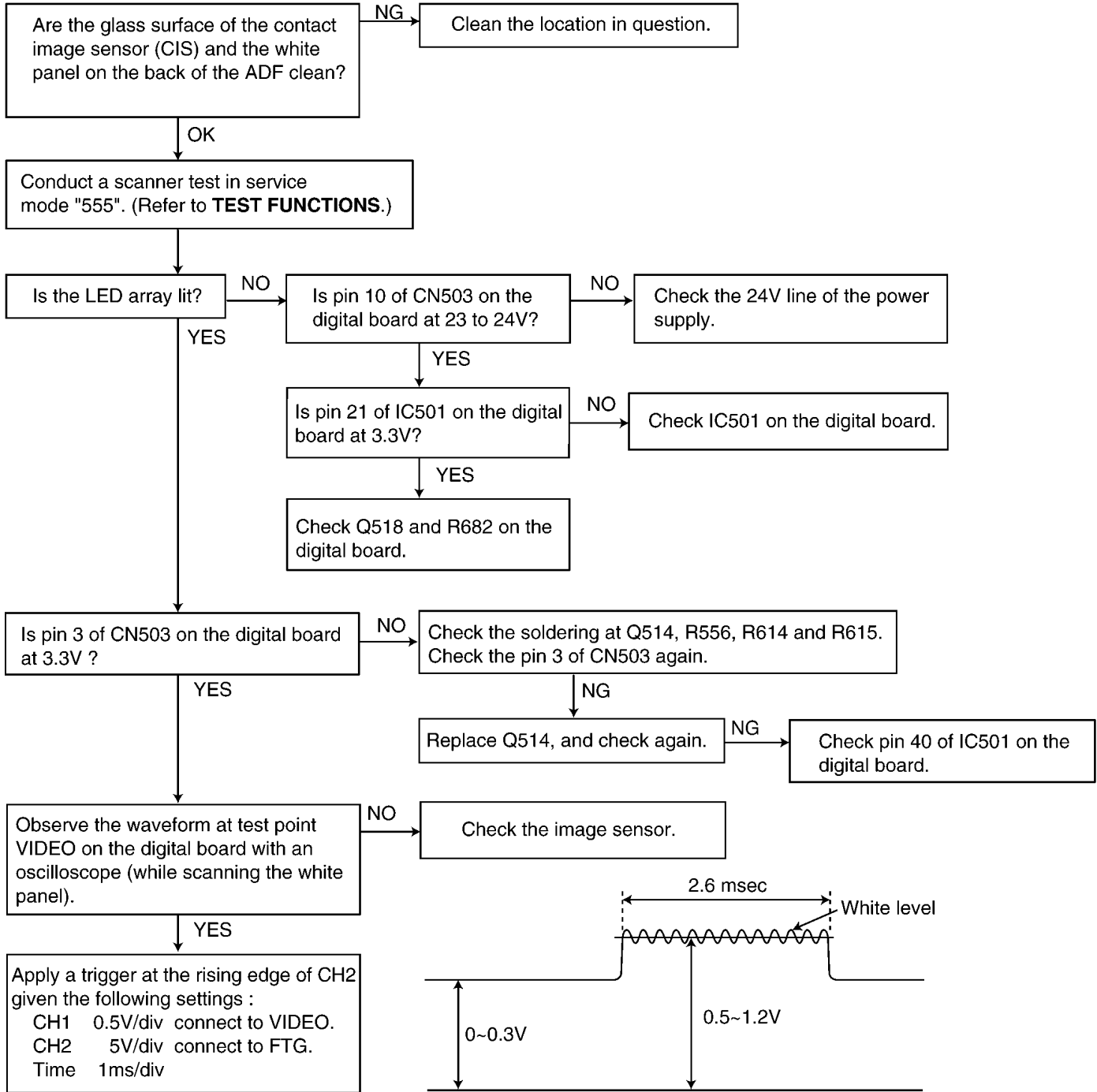

Digital Board  
(Component View)

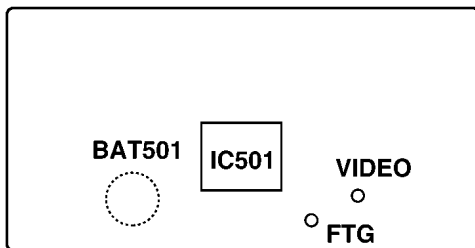

**CROSS REFERENCE:**

**TEST FUNCTIONS** (P.50)

### 6.6.13. THERMAL HEAD SECTION

Refer to **THERMAL HEAD**(P.129).

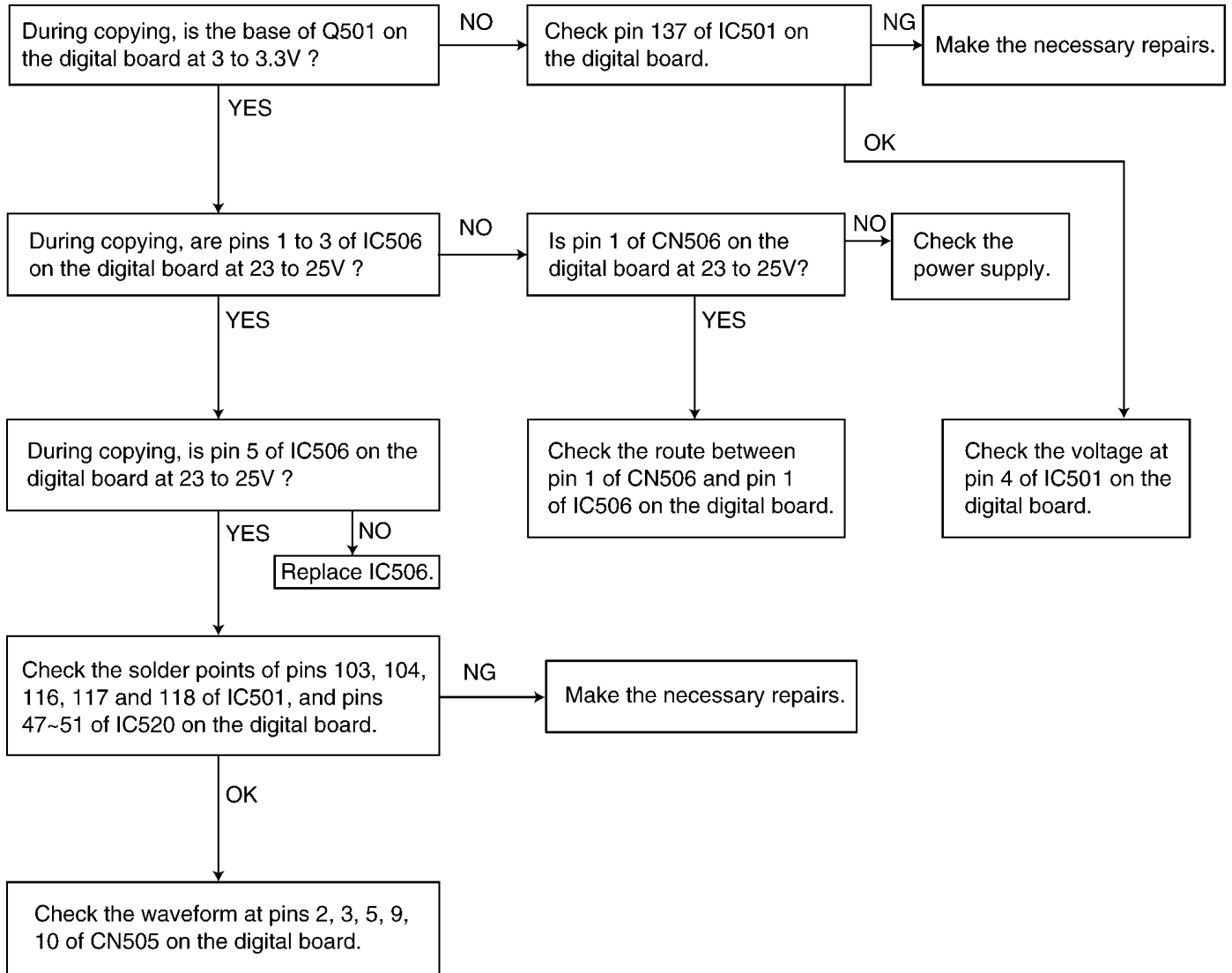

# 7 CIRCUIT OPERATIONS

## 7.1. CONNECTION DIAGRAM

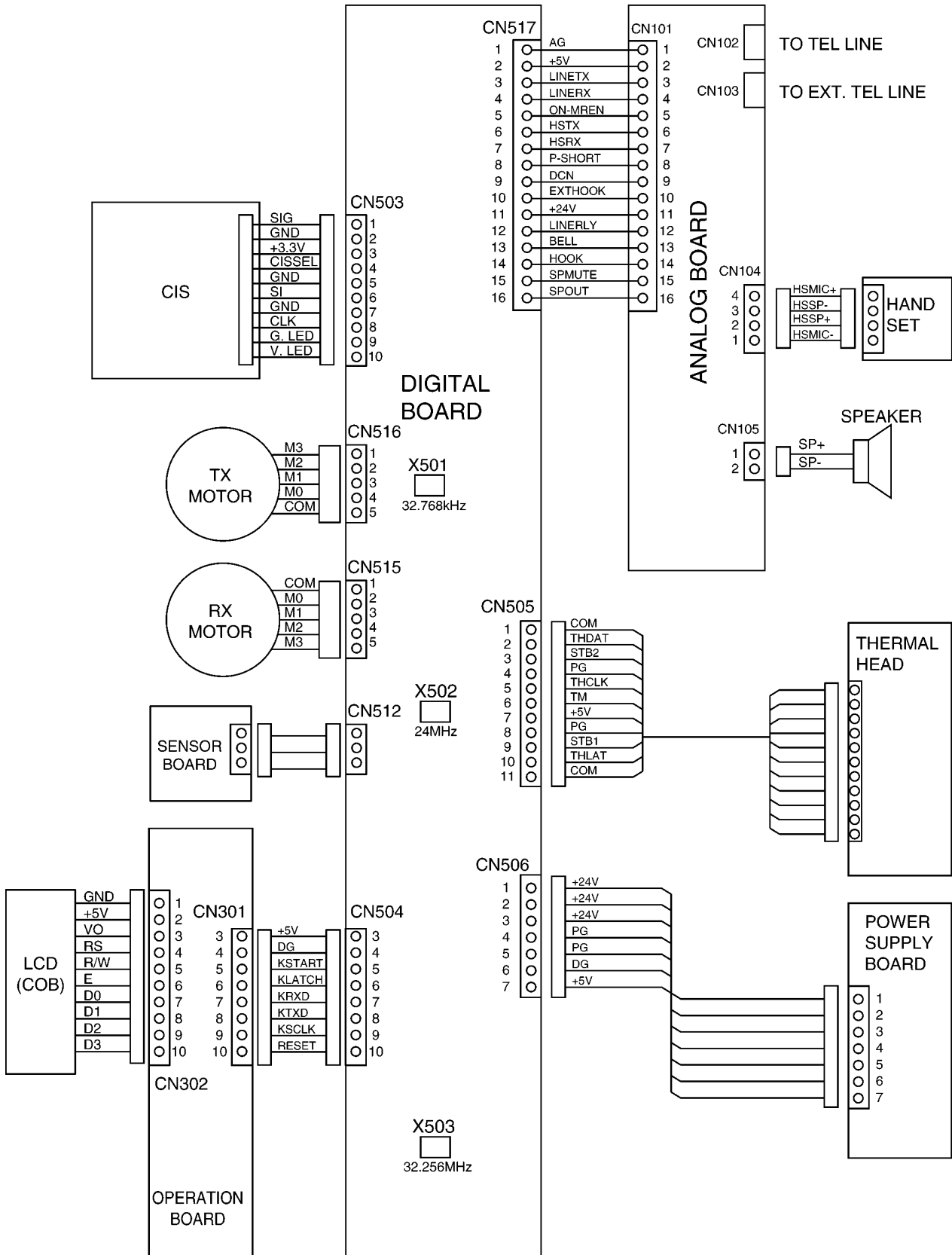

## 7.2. GENERAL BLOCK DIAGRAM

The following is an outline of each device IC on the digital board. (Refer to **GENERAL BLOCK DIAGRAM**(P.118).).

### 1. ASIC (IC501)

Composed mainly of an address decoder and a modem control.

Controls the general FAX operations.

Controls the operation panel I/F.

Controls the thermal head I/F and CIS I/F.

Performs the image processing.

CPU and Real time clock

### 2. Flash ROM (IC523)

Contains all of the program instructions on the unit operations.

This memory is used mainly for the parameter working in the storage area.

### 3. Dynamic RAM (IC503)

This memory is used mainly for the parameter working in the storage area.

### 4. MODEM (IC505)

Performs the modulation and the demodulation for FAX communication.

### 5. Read Section

CIS image sensor to read transmitted documents.

### 6. Motor Driver (IC508 and IC510)

Drives the transmission motor and the reception motor.

### 7. Thermal Head

Contains heat-emitting elements for dot matrix image printing.

### 8. Analog Board

Composed of ITS circuit and NCU circuit.

### 9. Sensor Section

Composed of a cover open and film detection switch, a document set switch, a document top switch, a paper top sensor.

### 10. Power Supply Board Switching Section

Supplies +5V and +24V to the unit.

### 7.2.1. GENERAL BLOCK DIAGRAM

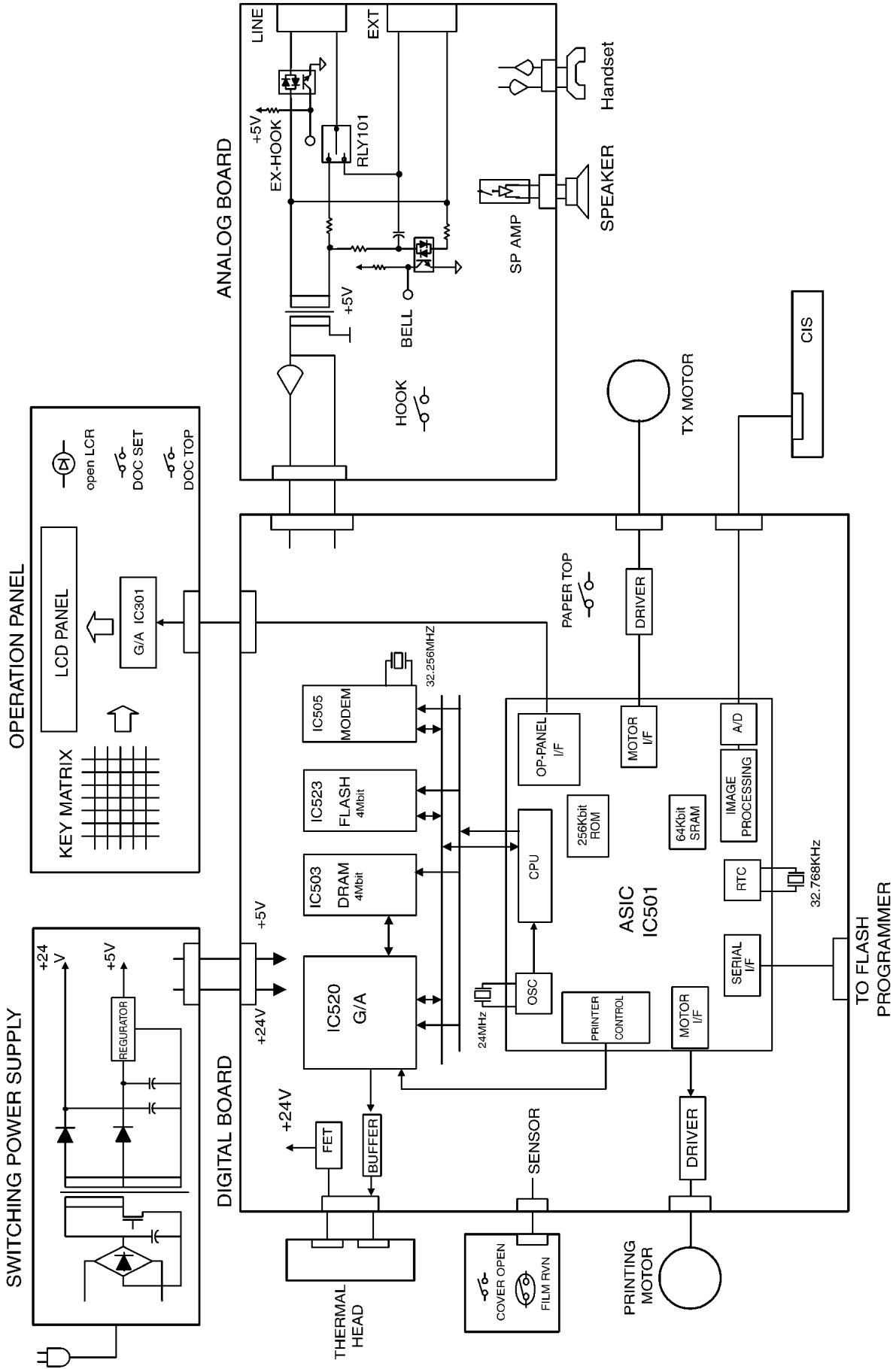

### 7.3. CONTROL SECTION

#### 7.3.1. BLOCK DIAGRAM

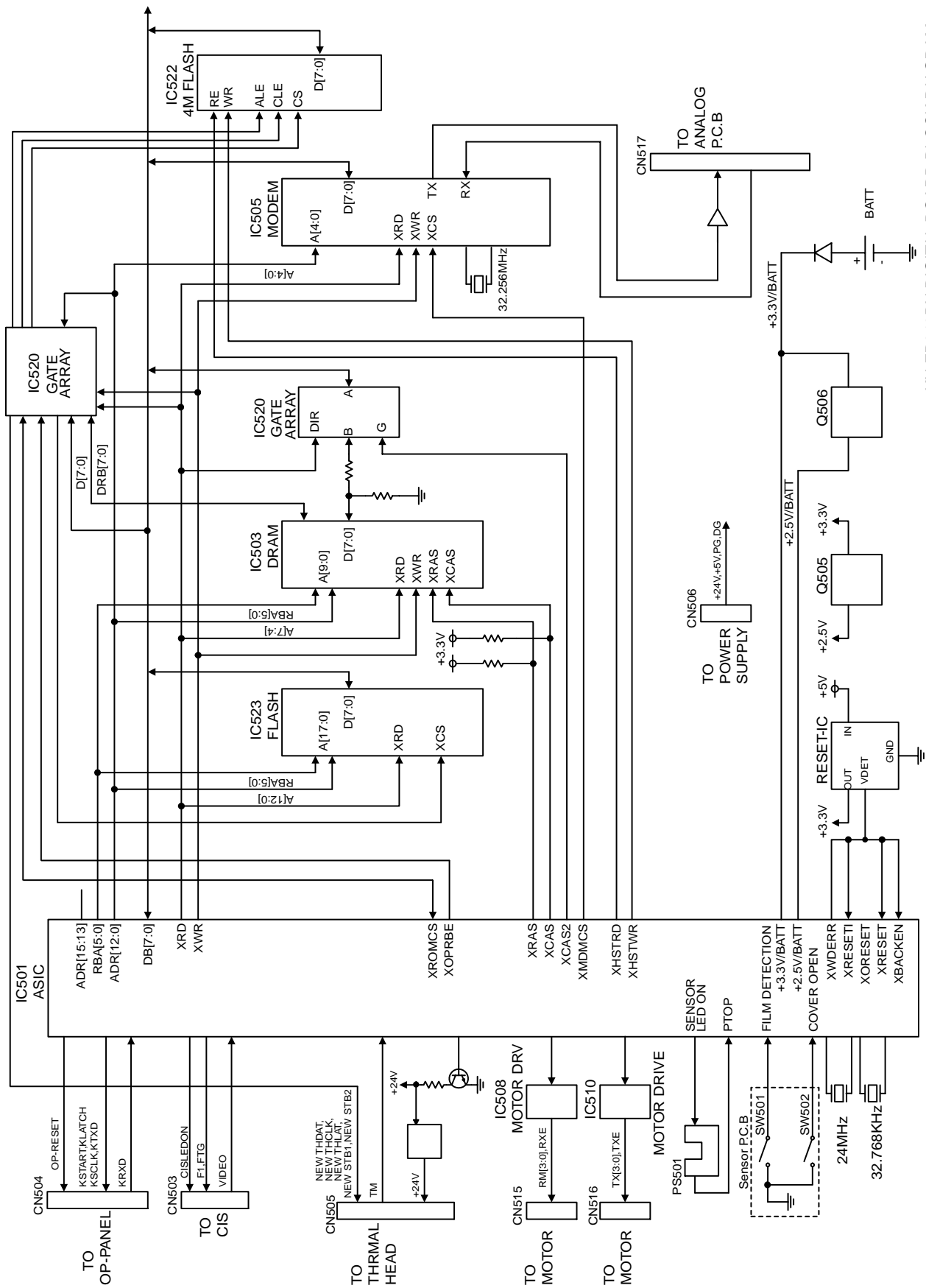

KX-FP342BX: DIGITAL BOARD BLOCK DIAGRAM

### 7.3.2. MEMORY MAP

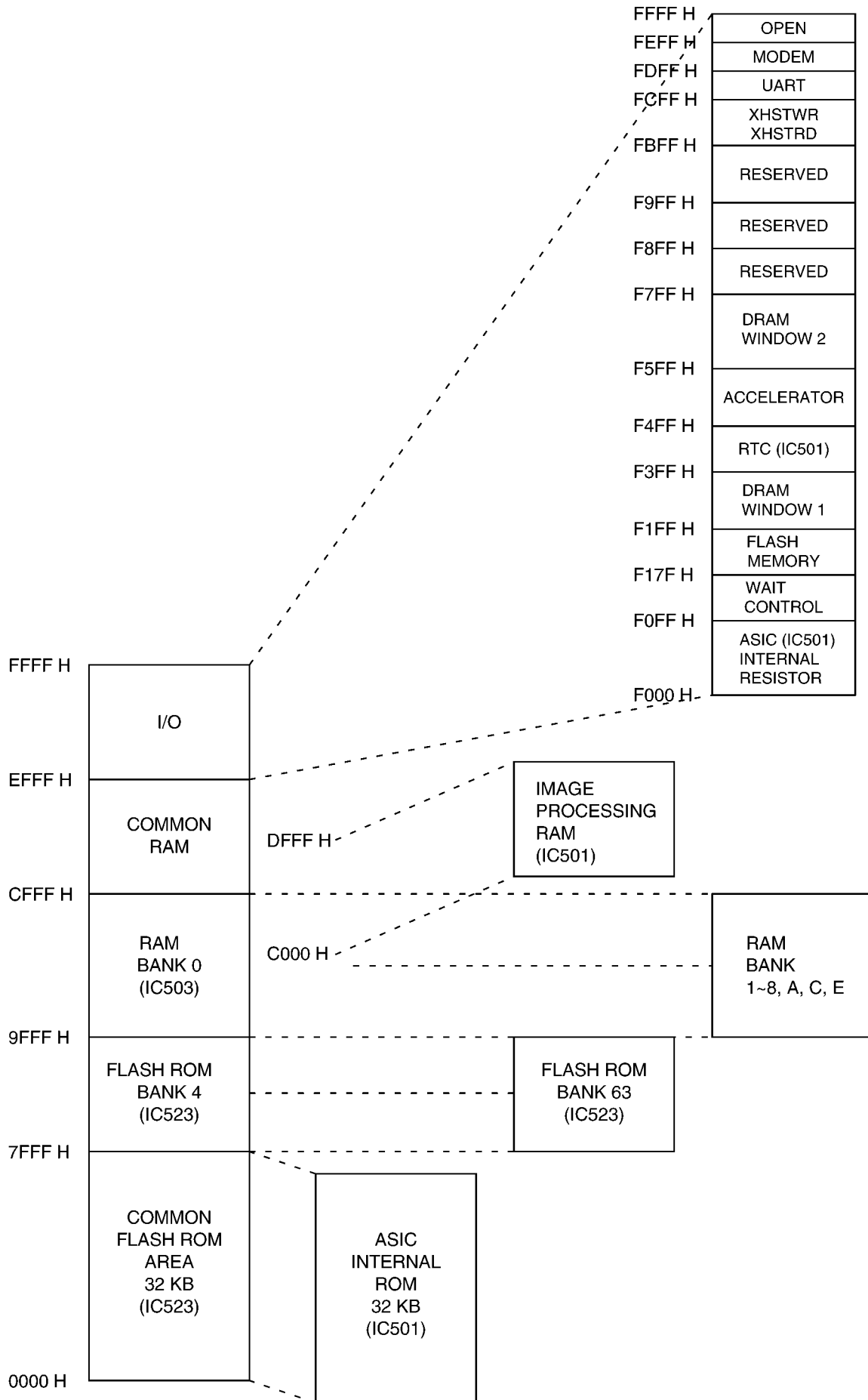



### 7.3.3. ASIC (IC501)

This custom IC is used for the general FAX operations.

1. CPU:

This model uses a Z80 equivalent to the CPU operating at 12 MHz. Most of the peripheral functions are performed by custom-designed LSIs. Therefore, the CPU only works for processing the results.

2. RTC:

Real Time Clock

3. DECODER:

Decodes the address.

4. ROM/RAM I/F:

Controls the SELECT signal of ROM or RAM and the bank switching.

5. CIS I/F:

Controls the document reading.

6. IMAGE DATA RAM:

This memory is programmed into the ASIC and uses 8 KB for the image processing. (See Fig. A.)\*

7. THERMAL HEAD I/F:

Transmits the recorded data to the thermal head.

8. MOTOR I/F:

Controls the transmission motor which feeds the document.  
Controls the receiving motor which feeds the recording paper.

9. OPERATION PANEL I/F:

Serial interface with Operation Panel.

10. I/O PORT:

I/O Port Interface.

11. ANALOG UNIT:

Electronic volume for the handset and the monitor.  
Sends beep tones, etc.

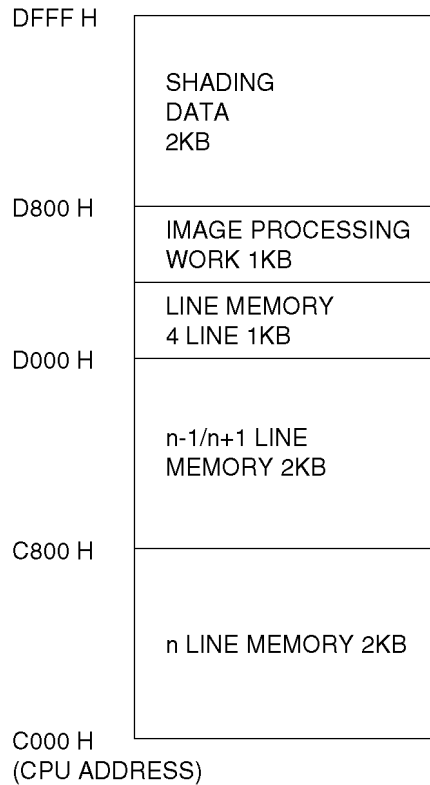

Fig. A

**Note\*:**

This memory is incorporated into the ASIC (IC501) and used for the image processing.

Fig. A shows the memory map of the Image Data RAM.

### 7.3.4. FLASH MEMORY (IC523)

The 512KB ROM (FLASH MEMORY) carries a common area of 32KB and bank areas which each have 8KB (BK4~BK63). The addresses from 0000H to 7FFFH are for the common area and from 8000H to 9FFFH are for the bank areas.

### 7.3.5. DYNAMIC RAM (IC503)

The DRAM serves as CPU and receives memory.

The address is F200H~F3FFH (DRAM access window 1) and F600H~F7FFH (DRAM access window 2).

#### Descriptions of Pin Distribution (IC501)

NO.	SIGNAL	I/O	POWER SUPPLIED VOLTAGE	DESCRIPTION
1	VSSA		GND	POWER SOURCE (ANALOG GND)
2	VDDA 3.3		3.3V	POWER SOURCE (ANALOG +3.3V)
3	AIN1	A	3.3V	CCD IMAGE SIGNAL INPUT
4	AIN2	A	3.3V	THERMISTOR TEMPERATURE WATCH INPUT
5	AIN3	A	3.3V	-----
6	AMON	A	3.3V	ANALOG SIGNAL MONITOR TERMINAL
7	VSS		GND	POWER SOURCE (GND)
8	X32OUT	O	3.3V/BATT	RTC (32.768KHz) CONNECTION
9	X32IN	I	3.3V/BATT	RTC (32.768KHz) CONNECTION
10	VDD (3.3V / B)		-----	POWER SOURCE (+3.3V/LITHIUM BATTERY)
11	XBACEN	I	3.3V/BATT	BACKUP ENABLE
12	XRAMCS	O	3.3V/BATT	NOT USED
13	VDD (3.3V / B)		-----	POWER SOURCE(+3.3V / LITHIUM BATTERY)
14	VDD (2.5V/B)		-----	POWER SOURCE (+2.5V / LITHIUM BATTERY)
15	FTG	O	3.3V	SH SIGNAL OUTPUT FOR CIS (SI)
16	F1	O	3.3V	01 SIGNAL OUTPUT FOR CIS (CLK)
17	F2/OP	O	3.3V	OUTPUT PORT (HSTXMUTE)
18	FR/OP	O	3.3V	OUTPUT PORT (MDMRST)
19	CPC	I	3.3V	INPUT PORT (PTOP)
20	RVN	I	3.3V	INPUT PORT (REED)
21	IRDATXD/IOP	O	3.3V	OUTPUT PORT (CISLED)
22	IRDARXD/IOP80	I	3.3V	INPUT PORT (DSR)
23	TXD/IOP	I	3.3V	INPUT PORT (TXD)
24	RXD/IOP	O	3.3V	OUTPUT PORT (SENLED1)
25	XRTS/IOP	I	3.3V	INPUT PORT (HOOK)
26	XCTS/IOP	O	3.3V	OUTPUT PORT (SPMUTE)
27	VDD (2.5V)		3.3V	POWER SOURCE (+2.5V)
28	TONE1	A	3.3V	TONE OUTPUT
29	TONE2	A	3.3V	TONE OUTPUT
30	VOLUREF	A	3.3V	ANALOG REF VOLTAGE
31	VOLUOUT	A	3.3V	VOLUME OUTPUT
32	VOLUIN	A	3.3V	VOLUME INPUT
33	XNMI	I	3.3V	HIGH FIXED
34	FMEMDO/IOP	O	3.3V	OUTPUT PORT (ON-MREN)
35	VDD (3.3V)		-----	POWER SOURCE (+3.3V)
36	VSS		GND	POWER SOURCE (GND)
37	VSS		GND	POWER SOURCE (GND)
38	VDD (3.3V)		-----	POWER SOURCE (+3.3V)
39	MIDAT/IOP	O	3.3V	OUTPUT PORT (TONE1EN)
40	MICLK/IOP	O	3.3V	OUTPUT PORT (CISON)
41	MILAT/IOP	O	3.3V	OUTPUT PORT (OPERESSET)
42	20KOSC/IOP	I	3.3V	INPUT PORT (BELL)
43	XWAIT	I	3.3V	INPUT PORT (KOVER)
44	HSTRD/IOP	O	3.3V	NOT USED
45	HSTWR/IOP	O	3.3V	NOT USED
46	XOPRBE	O	3.3V	MFCS
47	ADR15	O	3.3V	CPU ADDRESS BUS 15 (NOT USED)
48	ADR14	O	3.3V	CPU ADDRESS BUS 14 (NOT USED)
49	ADR13	O	3.3V	CPU ADDRESS BUS 13 (NOT USED)
50	VDD (2.5V)		-----	POWER SOURCE (+2.5V)
51	XOUT	O	3.3V	SYSTEM CLOCK (24MHz)
52	XIN	I	3.3V	SYSTEM CLOCK (24MHz)
53	VSS		GND	POWER SOURCE (GND)
54	VDD (3.3V)		-----	POWER SOURCE (+3.3V)
55	XTEST	O	3.3V	24MHz CLOCK
56	TEST1	I	3.3V	HIGH FIXED

NO.	SIGNAL	I/O	POWER SUPPLIED VOLTAGE	DESCRIPTION
57	TEST2	I	3.3V	HIGH FIXED
58	TEST3	I	3.3V	HIGH FIXED
59	TEST4	I	3.3V	HIGH FIXED
60	XMDMINT	I	3.3V	MODEM INTERRUPT
61	XMDMCS	O	3.3V	MODEM CHIP SELECT
62	XRAS/IOP	O	3.3V	DRAM (IC503) ROW ADDRESS STROBE
63	XCAS1/IOP	O	3.3V	DRAM (IC503) CULUM ADDRESS STROBE
64	XCAS2/IOP	O	3.3V	DRAM(IC503) CHIPSELECT
65	XRESCS2	O	3.3V	GATE ARRAY CHIP SELECT
66	DB3	I/O	3.3V	CPU DATA BUS 3
67	DB2	I/O	3.3V	CPU DATA BUS 2
68	DB4	I/O	3.3V	CPU DATA BUS 4
69	DB1	I/O	3.3V	CPU DATA BUS 1
70	DB5	I/O	3.3V	CPU DATA BUS 5
71	VDD (3.3V)		-----	POWER SOURCE (+3.3V)
72	VSS		GND	POWER SOURCE (GND)
73	VSS		GND	POWER SOURCE (GND)
74	VDD (3.3V)		3.3V	POWER SOURCE (+3.3V)
75	DB0	I/O	3.3V	CPU DATA BUS 0
76	DB6	I/O	3.3V	CPU DATA BUS 6
77	DB7	I/O	3.3V	CPU DATA BUS 7
78	XROMCS	O	3.3V	ROM (IC523) CHIP SELECT
79	RD	O	3.3V	CPU RD
80	WR	O	3.3V	CPU WR
81	ADR0	O	3.3V	CPU ADDRESS BUS 0
82	ADR1	O	3.3V	CPU ADDRESS BUS 1
83	ADR2	O	3.3V	CPU ADDRESS BUS 2
84	ADR3	O	3.3V	CPU ADDRESS BUS 3
85	ADR4	O	3.3V	CPU ADDRESS BUS 4
86	ADR5	O	3.3V	CPU ADDRESS BUS 5
87	VSS		GND	POWER SOURCE (GND)
88	VDD (2.5V)		-----	POWER SOURCE (+2.5V)
89	ADR6	O	3.3V	CPU ADDRESS BUS 6
90	ADR7	O	3.3V	CPU ADDRESS BUS 7
91	ADR8	O	3.3V	CPU ADDRESS BUS 8
92	ADR9	O	3.3V	CPU ADDRESS 9
93	ADR10	O	3.3V	CPU ADDRESS 10
94	ADR11	O	3.3V	CPU ADDRESS 11
95	ADR12	O	3.3V	CPU ADDRESS 12
96	RBA0	O	3.3V	ROM/RAM BANK ADDRESS 0
97	RBA1	O	3.3V	ROM/RAM BANK ADDRESS 1
98	RBA2	O	3.3V	ROM/RAM BANK ADDRESS 2
99	RBA3	O	3.3V	ROM/RAM BANK ADDRESS 3
100	RBA4	O	3.3V	ROM/RAM BANK ADDRESS 4
101	RBA5	O	3.3V	ROM/RAM BANK ADDRESS 5
102	RBA6/IOP96	O	3.3V	A19
103	STB1	O	3.3V	STROBE SIGNAL OUTPUT TO THERMAL HEAD
104	STB2	O	3.3V	STROBE SIGNAL OUTPUT TO THERMAL HEAD
105	STB3	O	3.3V	NOT USED
106	XRESET	I	3.3V	RESET INPUT
107	VDD (3.3V)		-----	POWER SOURCE (+3.3V)
108	VSS		GND	POWER SOURCE (GND)
109	VSS		GND	POWER SOURCE (GND)
110	VDD (3.3V)		-----	POWER SOURCE (+3.3V)
111	XORESET	O	3.3V	RESET OUTPUT
112	VDD(5V)		3.3V	POWER SOURCE (+5V)
113	VSS		GND	POWER SOURCE (ANALOG GND)
114	XRESETI	I	3.3V	RESET INPUT
115	WDERR	O	3.3V	WATCHED ERROR OUTPUT SIGNAL
116	THDAT	O	3.3V	RECORDED IMAGE OUTPUT
117	THCLK	O	3.3V	CLOCK OUTPUT FOR DATA TRANSFER
118	THLAT	O	3.3V	PULSE OUTPUT FOR DATA LATCH
119	STBNP	I	3.3V	INPUT PORT (TEST)
120	RM0/IOP	O	3.3V	RX MOTOR A PHASE
121	RM1/IOP	O	3.3V	RX MOTOR B PHASE
122	RM2/IOP	O	3.3V	RX MOTOR /A PHASE

NO.	SIGNAL	I/O	POWER SUPPLIED VOLTAGE	DESCRIPTION
123	RM3/IOP	O	3.3V	RX MOTOR /B PHASE
124	RXE/IOP	O	3.3V	RX MOTOR ENABLE SIGNAL
125	TMO	O	3.3V	TX MOTOR A PHASE
126	VDD (2.5V)		3.3V	POWER SOURCE (+2.5V)
127	VSS		GND	POWER SOURCE (GND)
128	TM1/IOP	O	3.3V	TX MOTOR B PHASE
129	TM2/IOP	O	3.3V	TX MOTOR /A PHASE
130	TM3/IOP	O	3.3V	TX MOTOR /B PHASE
131	TXE/IOP	O	3.3V	TX MOTOR ENABLE SIGNAL
132	KSTART	O	3.3V	OPERATION PANEL CONTROL
133	KLATCH	O	3.3V	OPERATION PANEL CONTROL
134	KSCLK	O	3.3V	OPERATION PANEL CONTROL
135	KTXD	O	3.3V	OPERATION PANEL CONTROL
136	KRXD	I	3.3V	OPERATION PANEL CONTROL
137	FMEMCLK/IOP	O	3.3V	OUTPUT PORT (THON)
138	FMEMDI/IOP	O	3.3V	OUTPUT PORT (LINERLY)
139	ADSEL1	O	3.3V	CHANNEL SELECT SIGNAL FOR AIN2
140	VDDA (2.5V)		3.3V	POWER SOURCE (ANALOG +2.5V)
141	VREFB	A	2.5V	A/D CONVERTER'S ZERO STANDARD VOLTAGE OUTPUT
142	VCL	A	3.3V	ANALOG PART STANDARD VOLTAGE SIGNAL
143	VREFT	A	3.3V	A/D CONVERTER'S FULL SCALE VOLTAGE OUTPUT
144	VSSA		GND	POWER SOURCE (ANALOG GND)

### 7.3.6. RESET CIRCUIT (WATCH DOG TIMER)

The output signal (reset) from pin 4 of the voltage detect IC (IC507) is input to the ASIC (IC501) 114 and 106 pins.

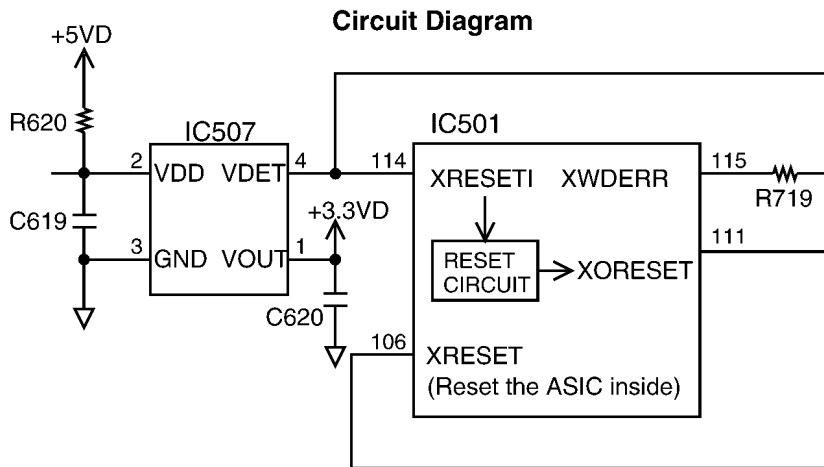

1. During a momentary power interruption, a positive reset pulse of 50~70 msec is generated and the system is reset completely.

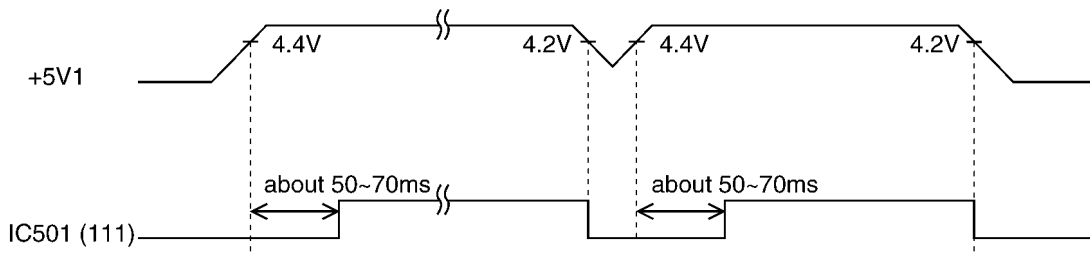

2. The watch dog timer, built-in the ASIC (IC501), is initialized by the CPU about every 1.5 ms.

When a watch dog error occurs, pin 115 of the ASIC (IC501) becomes low level.

The terminal of the 'WDERR' signal is connected to the reset line, so the 'WDERR' signal works as the reset signal.

### 7.3.7. RTC BACKUP CIRCUIT

#### 1. Function

This unit has a lithium battery (BAT501) which works for Real Time Clock IC (RTC: inside IC501).  
 The RTC continues to work, backed up by a lithium battery even when the power switch is OFF.  
 The user parameters for autodial numbers, the system setup data and others are in the FLASH ROM (IC523).

#### 2. RTC Inside (IC501) Backup Circuit Operation

When the power switch is turned ON, power is supplied through Q506 to the RTC (inside IC501). At this time, the voltage at pin 14 of the IC501 is +2.5V. When the power switch is turned OFF, the BAT501 supplies power to RTC through D503 and Q506. The voltage at pin 14 of IC501 is about +2.2V. When the power switch is OFF and the voltage of +3.3V decreases, pin 14 of RTC (IC501) becomes roughly the same voltage as the battery voltage. RTC goes into the backup mode, in which the power consumption is lower.

**Circuit Diagram**

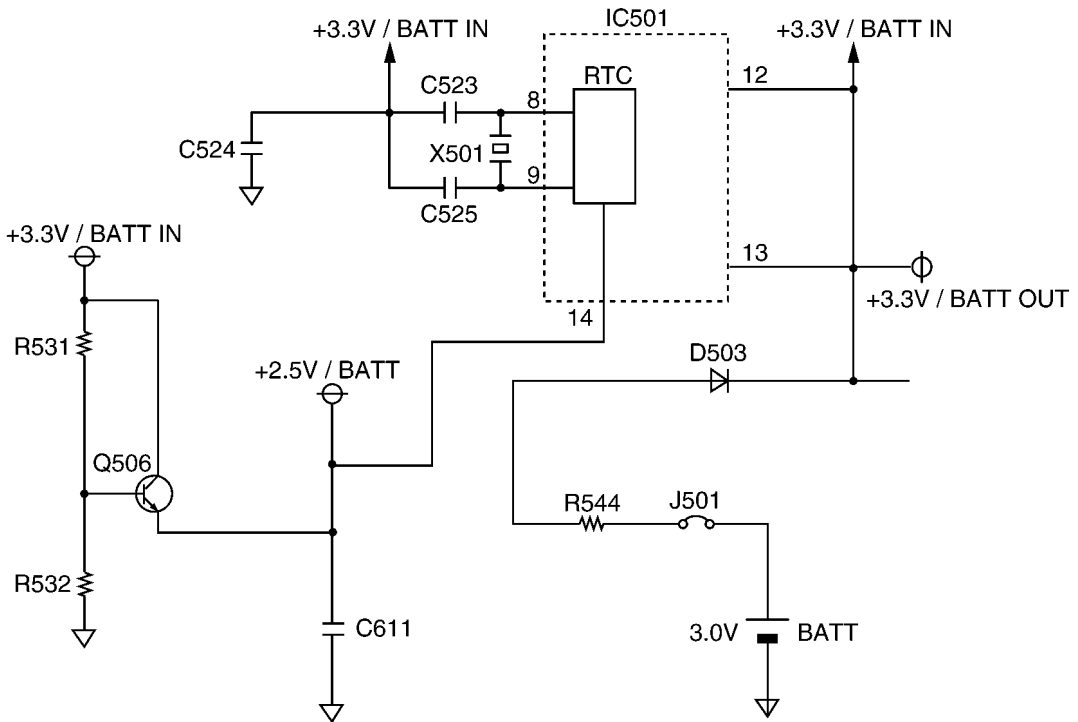

### 7.3.8. SUPERVISION CIRCUIT FOR THE THERMAL HEAD TEMPERATURE

#### 1. Function

The thermistor changes the resistor according to the temperature and uses the thermistor's characteristics. The output of pin 137 of IC501 becomes a low level. Then when it becomes a high level, it triggers point A. In point C, according to the voltage output time, the thermal head's temperature is detected.

After the thermal head temperature is converted to voltage in B, it is then changed to digital data in the A/D converter inside IC501. The CPU decides the strobe width of the thermal head according to this value. Therefore, this circuit can keep the thermal head at an even temperature in order to stabilize the printing density and prevent the head from being overheated.

**Circuit Diagram**

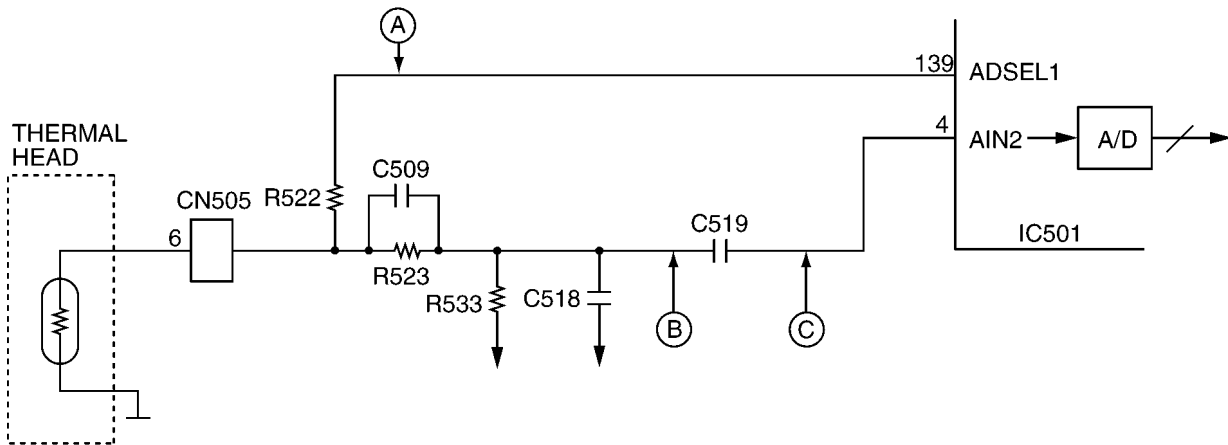

**Timing Chart**

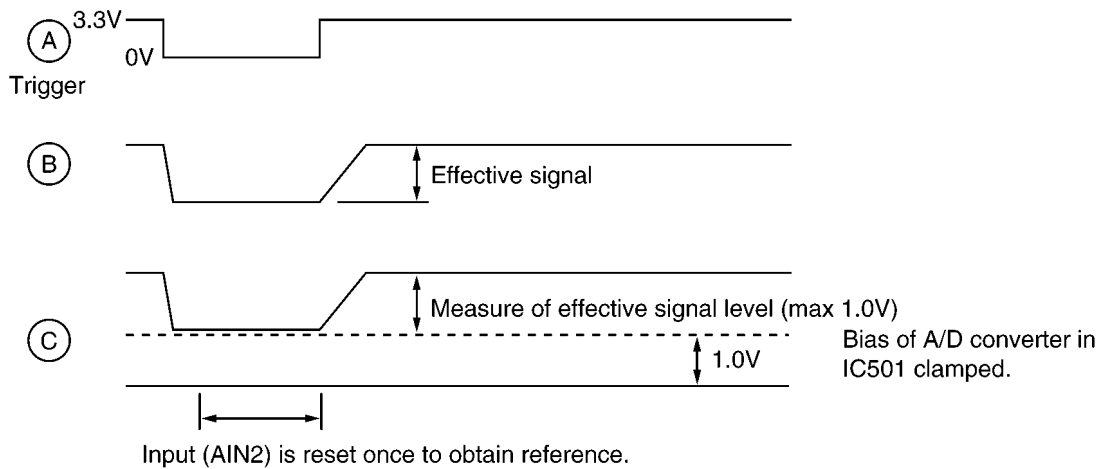

## 7.4. FACSIMILE SECTION

### 7.4.1. IMAGE DATA FLOW DURING FACSIMILE OPERATION

#### Copy (Fine, Super-Fine, Half Tone)

1. Line information is read by CIS (to be used as the reference white level) via route1, and is input to IC501. Refer to **BLOCK DIAGRAM**(P.128)
2. In IC501, the data is adjusted to a suitable level for A/D conversion in the Analog Signal Processing Section, and via route2 it is input to A/D conversion (8 bit). After finishing A/D conversion, the data is input to the Image Processing Section via route3. Then via route4 and route5, it is stored in RAM as shading data.
3. The draft's information that is read by CIS is input to IC501 via route1. After it is adjusted to a suitable level for A/D conversion via route2, the draft's information is converted to A/D (8 bit), and it is input to the Image Processing Section. The other side, the shading data which flows from RAM via route6 and route7, is input to the Image Processing Section. After finishing the draft's information image processing, white is regarded as "0" and black is regarded as "1". Then via routes4 and 5, they are stored in RAM.
4. The white/black data stored as above via routes6 and 8 is input to the P/S converter. The white/black data converted to serial data in the P/S converter is input to the Thermal Head via route9 and is printed out on recording paper.

#### Note:

- Standard: Reads 3.85 times/mm
- Fine: Reads 7.7 times/mm
- Super-Fine: Reads 15.4 times/mm

#### Transmission

1. Same processing as **Copy** items 1 - 3.
2. The data stored in the RAM of IC501 is output from IC501 via routes6 and 10, and is stored in the system bus. Via route11, it is stored in the communication buffer inside DRAM (IC503).
3. While retrieving data stored in the communication buffer synchronous with the modem, the CPU (inside IC501) inputs the data to the modem along route12, where it is converted to serial analog data and forwarded over the telephone lines via the NCU Section.

#### Reception

1. The serial analog image data is received over the telephone lines and input to the modem via the NCU section, where it is demodulated to parallel digital data. Then the CPU (IC501) stores the data in the communication buffer DRAM (IC503) along route12.
2. The data stored in DRAM (IC503) is decoded by the CPU (IC501) via route12, and is stored in DRAM (IC503) via routes13 and 5.
3. Same processing as **Copy** item 4.

### 7.4.2. BLOCK DIAGRAM

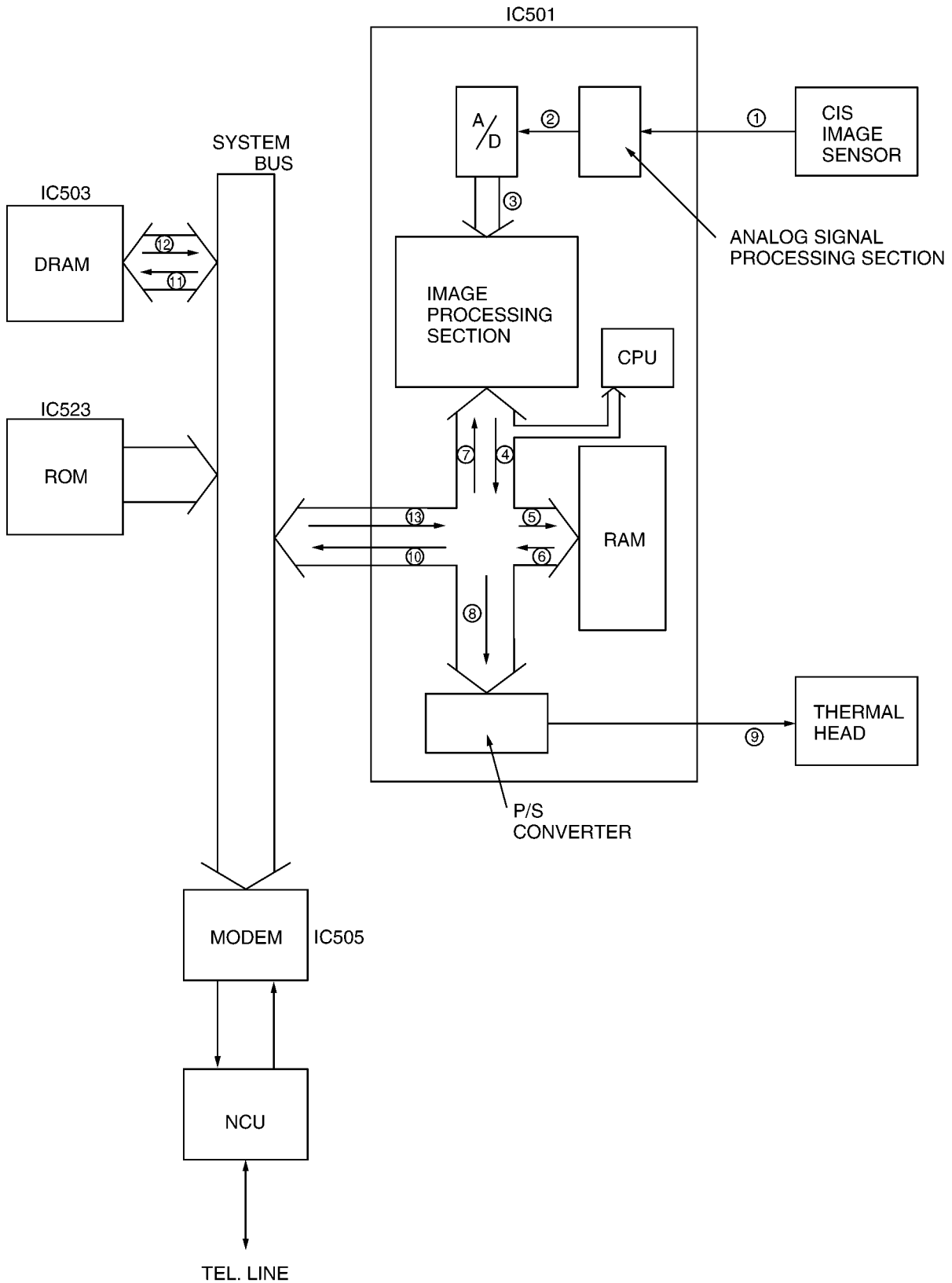



## 7.4.3. THERMAL HEAD

### 1. Function

This unit utilizes the state of the art thermal printer technology.

The ink film is chemically processed. The ink film is comprised of two parts: an ink layer and a base film. When the thermalhead contacts this ink film, it emits heat momentarily, and the ink layer is melted and transferred to the paper. If this continues, letters and/or diagrams appear, and the original document is reproduced.

#### COMPOSITION OF THE RECEIVE RECORD SECTION (THERMAL RECORDING FORMAT)

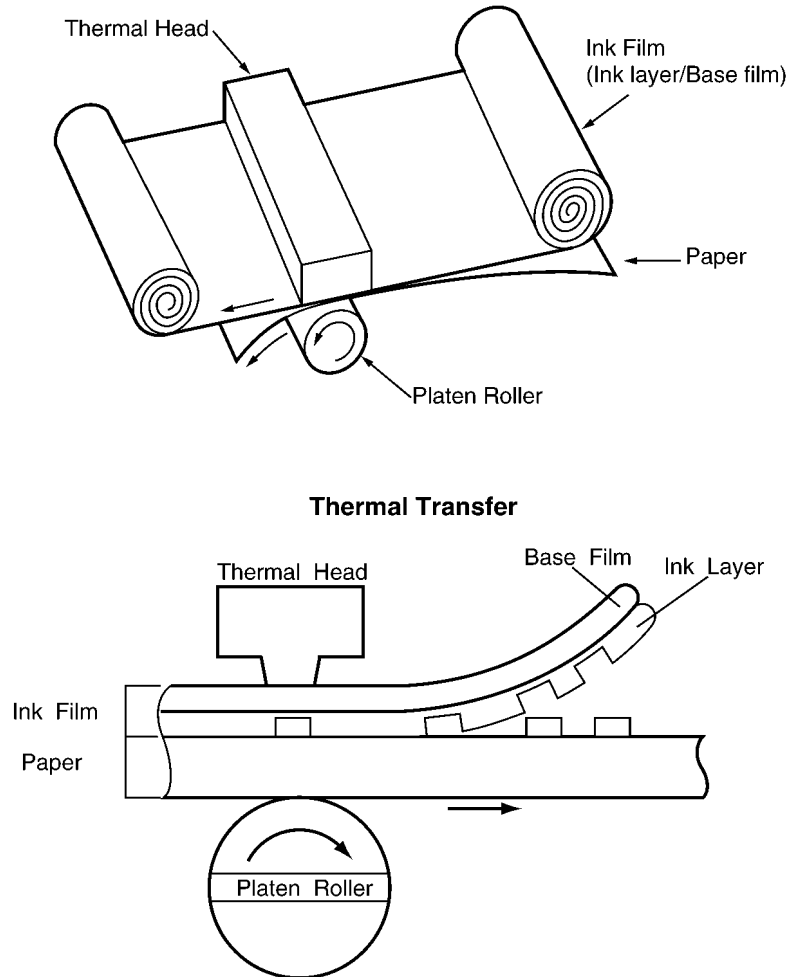

### 2. Circuit Operation

Refer to the block diagram and the timing chart on the following page.

There are 9 driver ICs aligned horizontally on the thermal head and each one of these ICs can drive 192 heat-emitting registers. This means that one line is at a density of  $192 \times 9 = 1728$  dots  $\approx$  (8 dots/mm).

White/Black (white=0, black=1) data in one line increment is synchronized at IC520 pin 39 (NEWTHCLK), and sent from IC520 pin 40 (NEWTHDAT) to the shift register of the ICs. The shift registers of the 9 ICs are connected in series, and upon the shift of the 1728 dot increment, the shift register becomes filled with data, and a latch pulse is emitted to each IC from IC520 pin 38 (NEWTHLAT).

With this latch pulse, all the contents of the shift registers are latched to the latch registers. Thereafter, through the addition of strobes from the IC520 pins 44 and 45, only the dot location of black (=1) among latched data activates the driver, and the current passes to heat the emitting body to cause heat emission.

Here, the two line strobes, NEWSTB1 to NEWSTB2, impress as required for one-line printout.

When the thermal head is not used, the IC501 pin 137 (THON) becomes low, Q501 turns OFF, IC506 turns OFF, and the +24V power supply for the thermal head driver is not impressed to protect the IC.

### 3. Print Speed of Copier

2ppm→4ppm when copied meeting with the following conditions;

- (1) Resolution: Fine
- (2) Scale: 100%
- (3) Print duty: 50% or less

\*standard chart: ITU-T No.1 (Refer to **ITU-T No.1 TEST CHART** (P.162).)

#### (i) Print Duty 50% or less

The sequence is shown on **TIMING CHART** (P.131).

When print duty is 50% or less, IC520 pin 44 and 45 (NEWSTB1/NEWSTB2) are composed IC501 pin 103 (STB1) and IC501 pin 104 (STB2). (logic-AND)

[Print speed of one-line: 4.608msec]

#### (ii) Print Duty more than 50%

The sequence is shown on **TIMING CHART** (P.131).

When print duty is more than 50%, IC520 pin 45 (NEWSTB1) and IC501 pin 103 (STB1) are the same signal.

[IC520 pin 44 (NEWSTB2) and IC501 pin 104 (STB2) are the same signal.]

[Print speed of one-line: 4.608msec x 2 = 9.216msec]

### Circuit Diagram

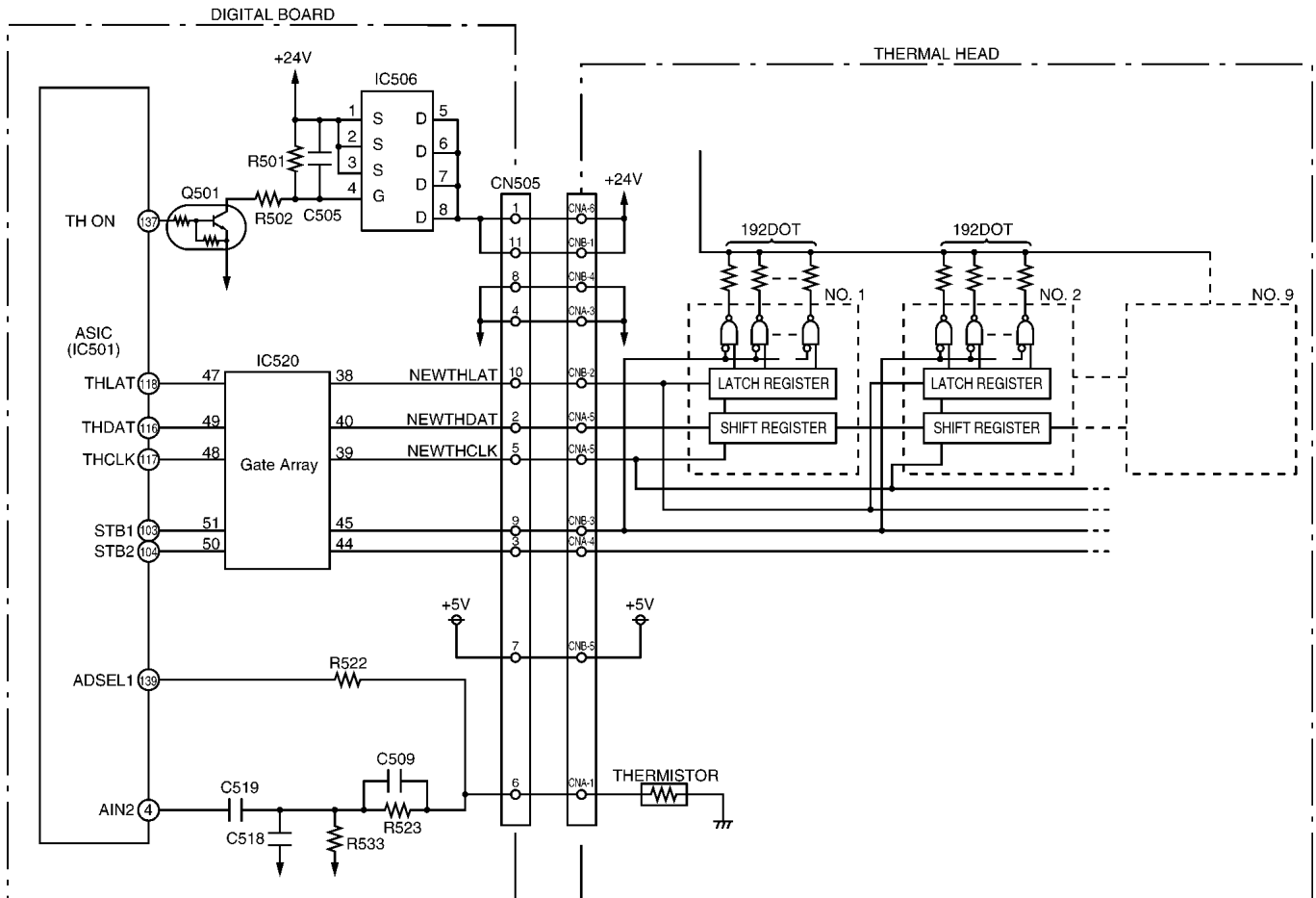

**TIMING CHART**

**(i) Print Duty 50% or less**

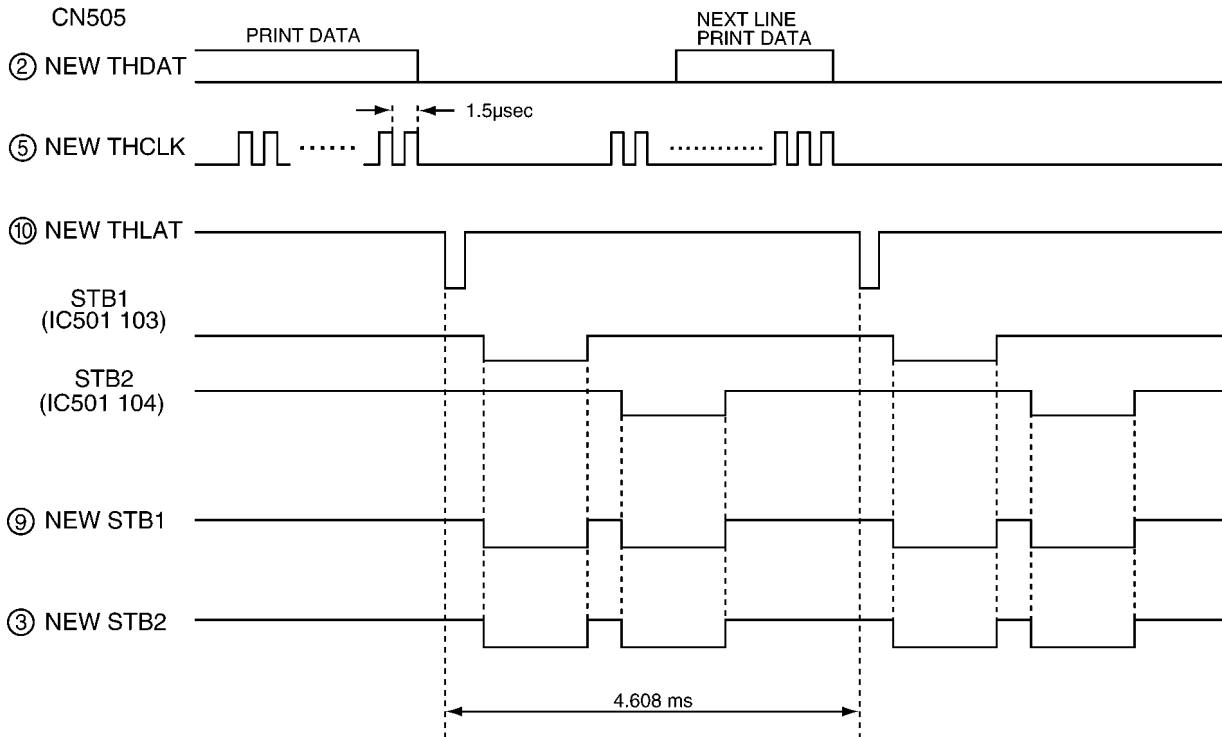

**(ii) Print Duty more than 50%**

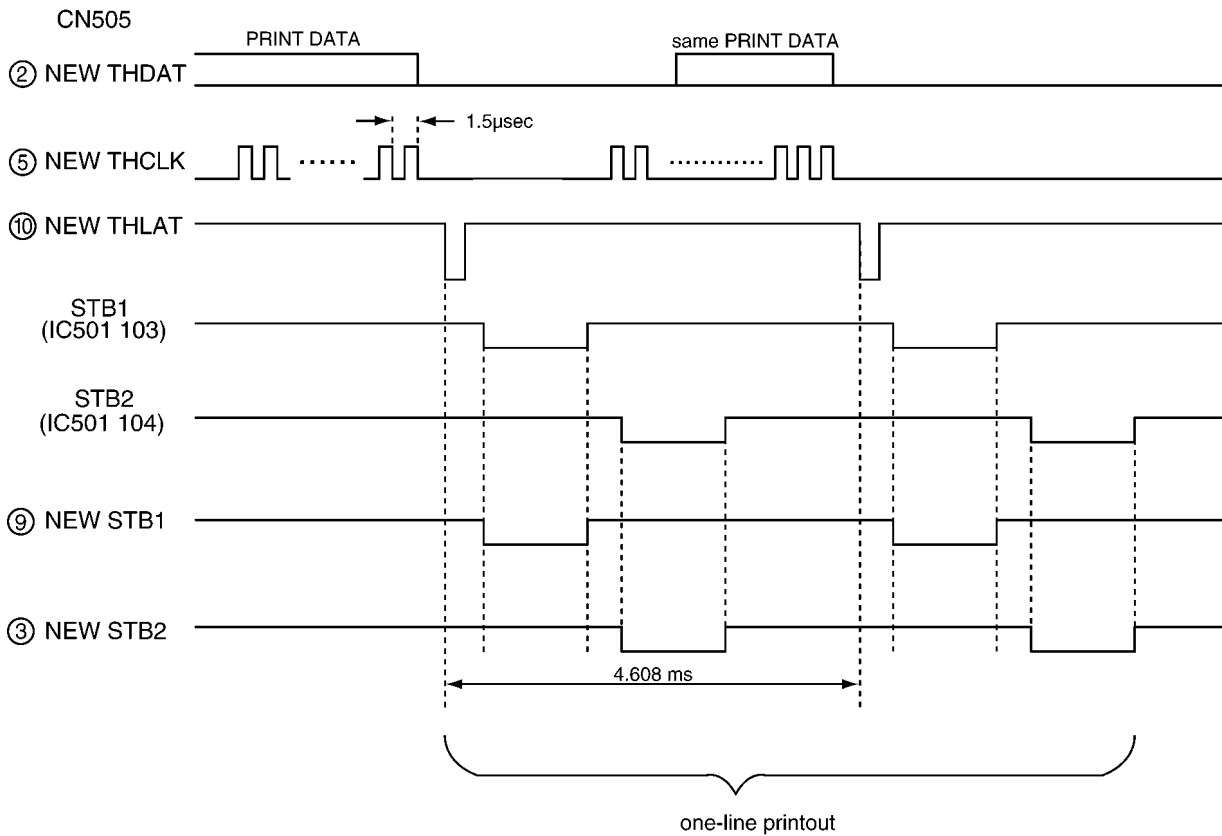

### 7.4.4. SCANNING BLOCK

The scanning block of this device consists of a control circuit and a contact image sensor made up of a celfoc lens array, an LED array, and photoelectric conversion elements.

**Circuit Diagram**

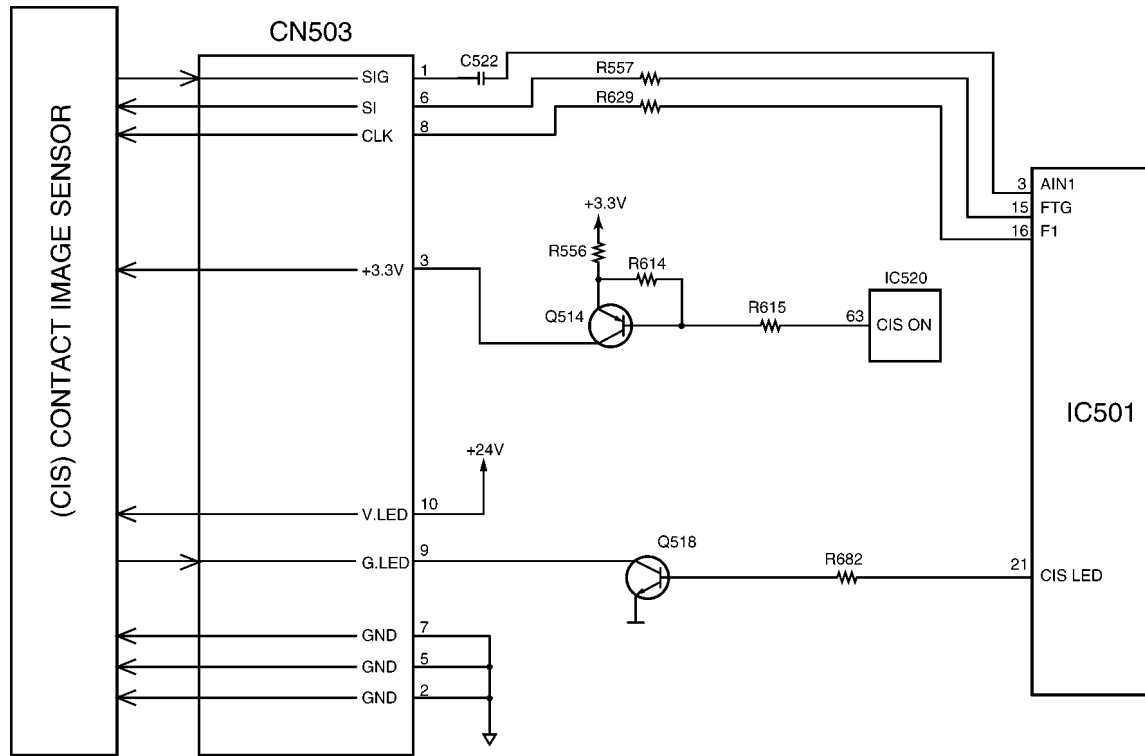

When an original document is inserted and the start button pressed, pin 21 of IC501 goes to a high level and the transistor Q507 turns on. This applies voltage to the LED array to light it. The contact image sensor is driven by each of the FTG-F1 signals output from IC501, and the original image illuminated by the LED array undergoes photoelectric conversion to output an analog image signal (SIG). The analog image signal is input to the system ASIC on AIN1 (pin 3 of IC501) and converted into 8-bit data by the A/D converter inside IC501. Then this signal undergoes digital processing in order to obtain a high-quality image.

### 7.4.5. STEPPING MOTOR DRIVE CIRCUIT (TX)

#### 1. Function

The stepping motor works for transmission.

#### 2. Motor

During motor driving, pin 131 of ASIC IC501 becomes a high level, and Q507, Q504 turns ON. As a result, +24V is supplied to the motor coil.

Stepping pulses are output from ASIC IC501 pins, 125, 128~130, causing driver IC510 pins, 16~13 to drive the Motor Coil. The motor coil is energized sequentially in 2 phase increments, which causes a 1-step rotation. A 1-step rotation feeds 0.13 mm of document paper.

The timing chart is below.

**Stepping Monitor Timing Chart**

• 1-2 Phase

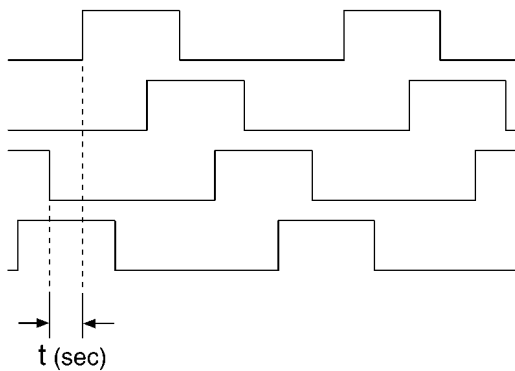

**Stepping Motor Drive Mode**

Function	Mode	Phase Pattern	Speed
Copy	Fine or photo	1-2	432 pps (t=1/432)
	Super Fine	1-2	216 pps (t=1/216)
Paper Feed	—	1-2	432 pps (t=1/432)
Stand-by	—	All phases are currently off.	None

**Circuit Diagram**

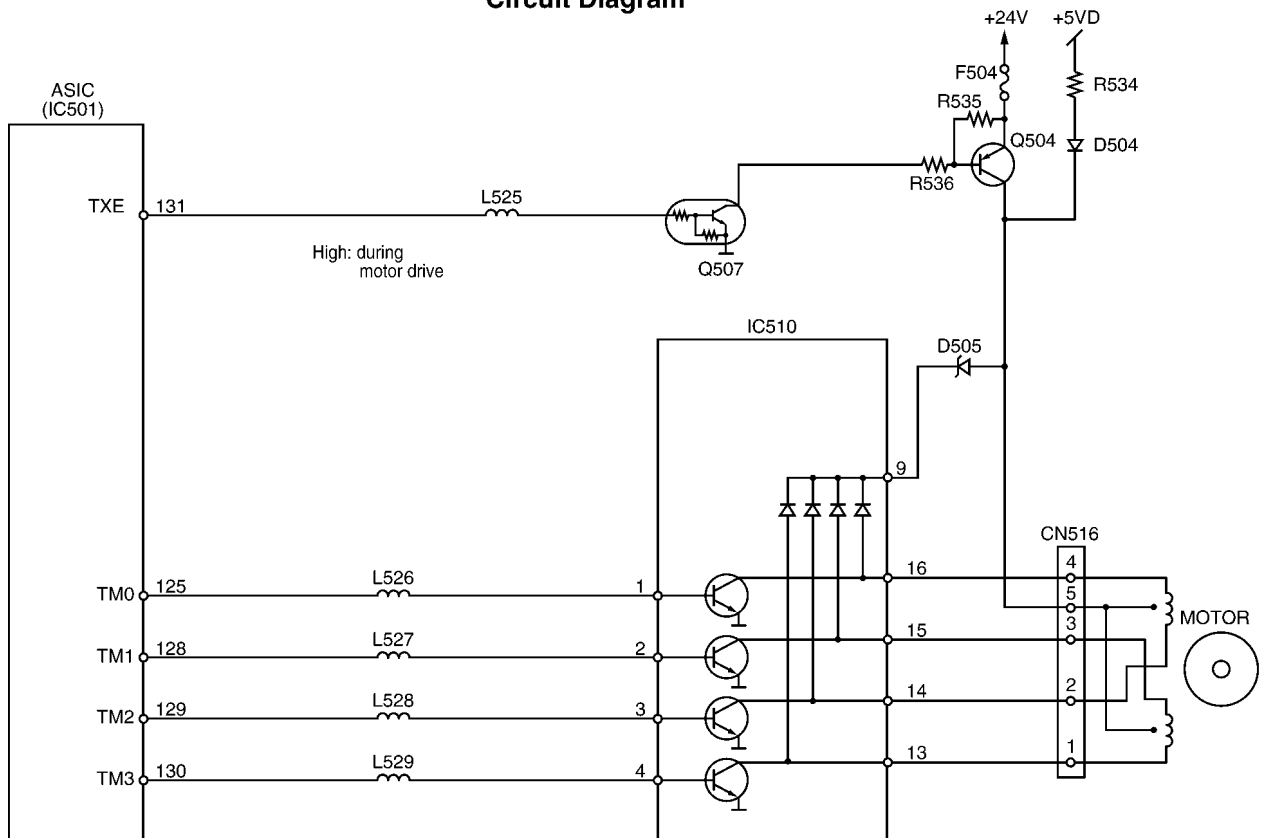

The motor suspends while it is in the receive mode (about 70~80 msec), pin 131 of ASIC IC501 becomes a low level and Q507 turns OFF. Then Q504 also turns OFF, and instead of +24 V, +5 V is supplied through D504 so that the motor is held in place. When the system is in the stand-by mode, all of the motor drive transistors turn OFF. Consequently, the motor current stops.

### 7.4.6. STEPPING MOTOR DRIVE CIRCUIT (RX)

**1. Function**

The stepping motor works for reception.

**2. Motor**

During motor driving, pin 124 of ASIC IC501 becomes a high level, and Q503, Q502 turns ON. As a result, +24V is supplied to the motor coil.

Stepping pulses are output from ASIC IC501 pins, 120~123, causing driver IC508 pins, 16~13 to drive the Motor Coil. The motor coil is energized sequentially in 2 phase increments, which causes a 1-step rotation. A 1-step rotation feeds 0.13 mm of recording paper.

The timing chart is below.

**Stepping Monitor Timing Chart**

• 1-2 Phase

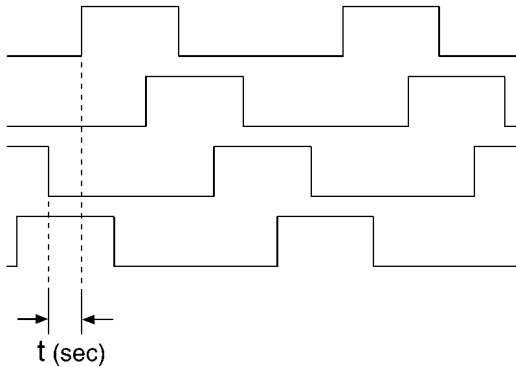

**Stepping Motor Drive Mode**

Function	Mode	Phase Pattern	Speed
Copy	Fine or photo	1-2	432 pps (t=1/432)
	Super Fine	1-2	216 pps (t=1/216)
Paper Feed	—	1-2	432 pps (t=1/432)
Stand-by	—	All phases are currently off.	None

**Circuit Diagram**

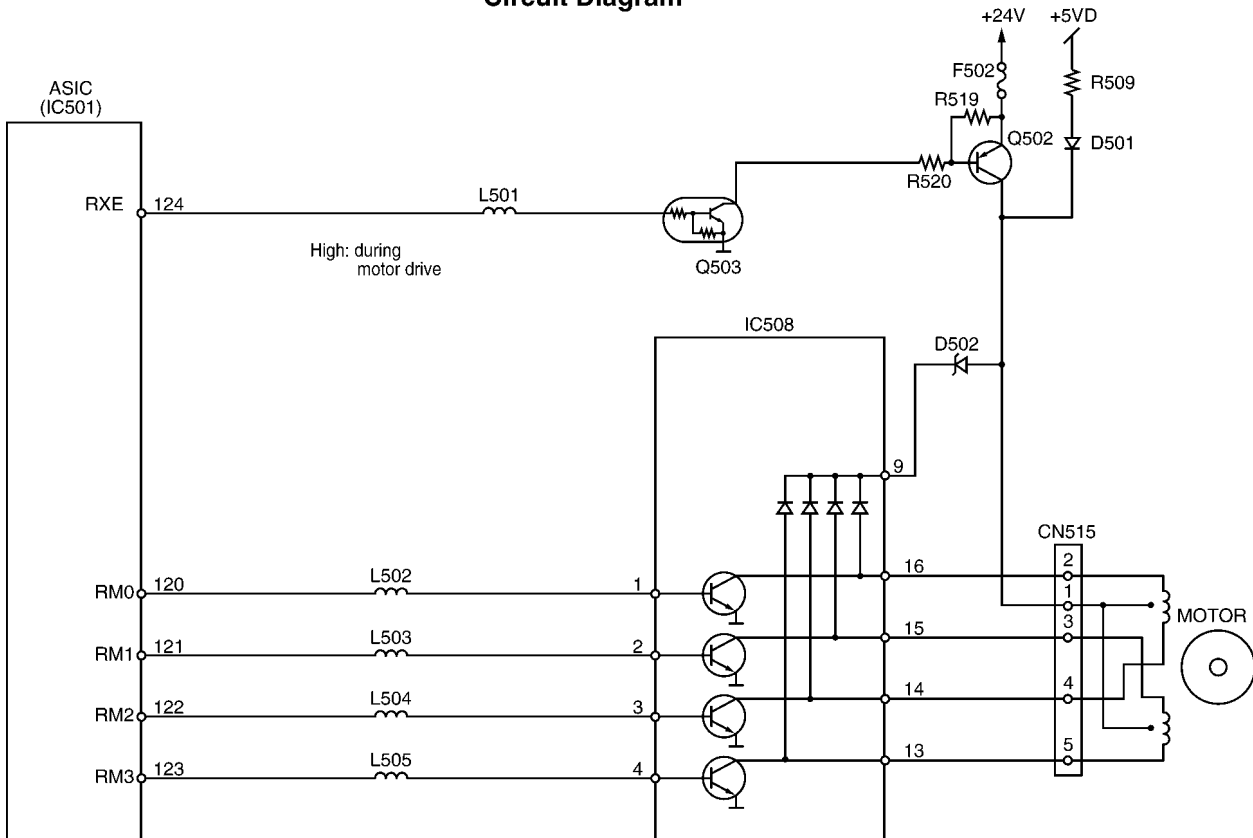

The motor suspends while it is in the receive mode (about 70~80 msec), pin 124 of ASIC IC501 becomes a low level and Q503 turns OFF. Then Q502 also turns OFF, and instead of +24 V, +5 V is supplied through D501 so that the motor is held in place. When the system is in the stand-by mode, all of the motor drive transistors turn OFF. Consequently, the motor current stops.

## 7.5. GEAR SECTION

Refer to **GEAR SECTION** (P.23) for Gear operation.

## 7.6. SENSORS AND SWITCHES

All of the sensor and switches are shown below. See **TEST FUNCTIONS**(P.50). (#815: Sensor Check)

Sensor Circuit Location	Sensor	Sensor or Switch Name	Message Error
Operation Panel	SW353	Document set SW	[CHECK DOCUMENT]
	SW352	Document top SW	[REMOVE DOCUMENT]
Digital PCB	PS501	Paper Top	[PAPER JAMMED]
Analog P.C.B	SW101	Hook	_____
Sensor P.C.B	SW501	Film Detection	[CHECK FILM SLACK]
	SW502	Cover Open SW	[COVER OPEN]

### Sensor Locations

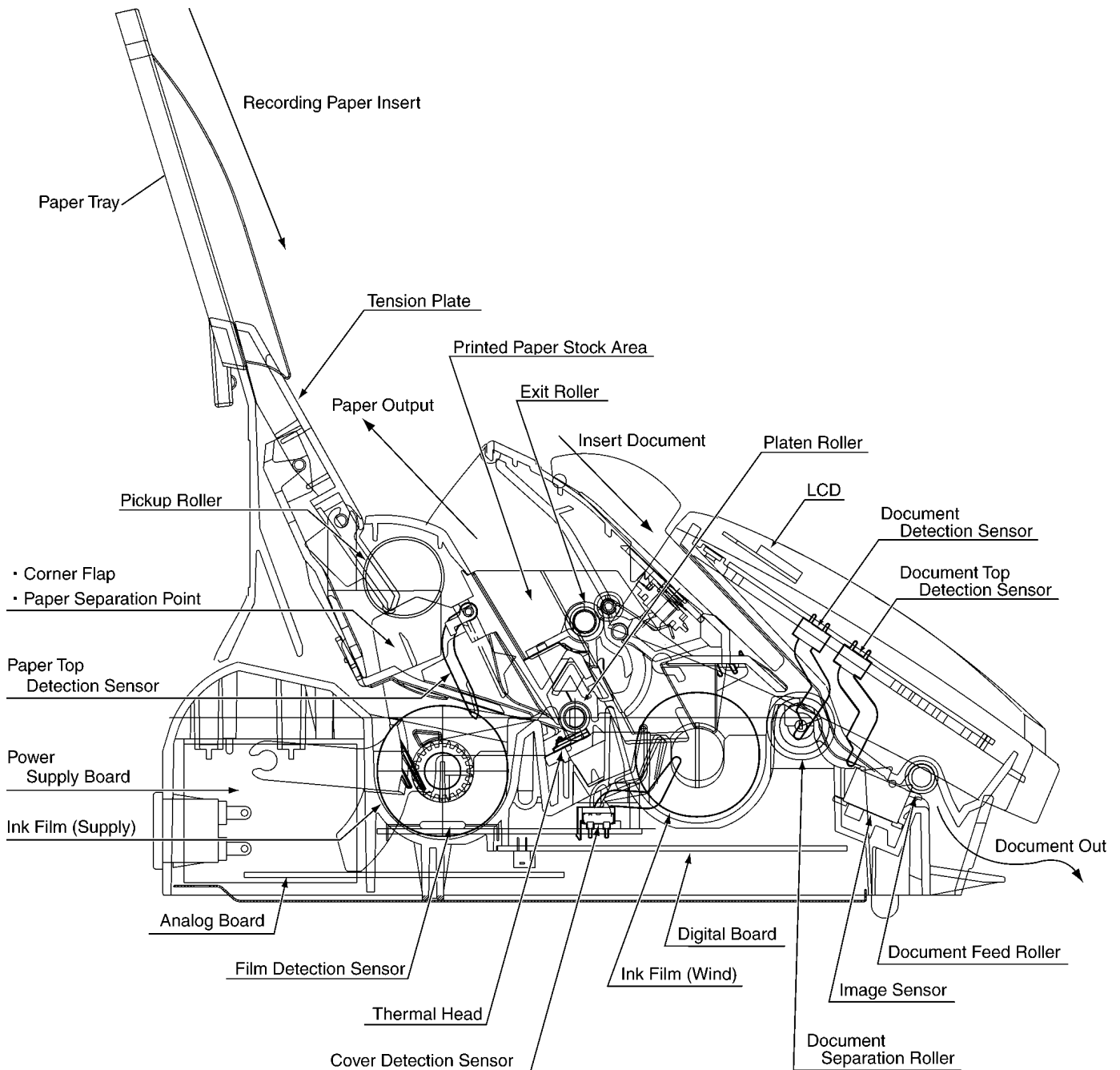

### 7.6.1. DOCUMENT TOP SW (SW352)....."REMOVE DOCUMENT"

When a document is brought to the read position, the SW turns ON, and the input signal of IC301-6 pin (Operation) becomes a low level. When there is no document at the read position, the SW turns OFF, and the input signal of IC301-6 pin (Operation) becomes a high level.

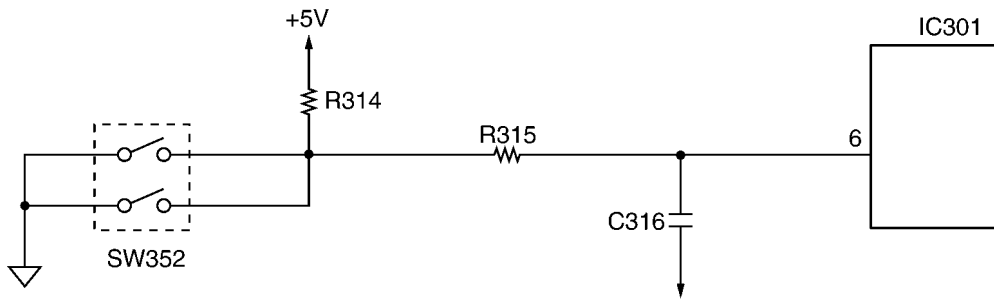

Operation Board		
	Photo transistor	Signal (IC301-6 pin)
Out of the Read Position	OFF	High level
At the Read Position	ON	Low level

### 7.6.2. DOCUMENT SET SW (SW353)....."CHECK DOCUMENT"

When a document is set, the SW turns ON, and the input signal of IC301-9 pin (Operation) becomes a low level. When there is no document, the SW turns ON, and the input signal of IC301-9 pin (Operation) becomes a high level.

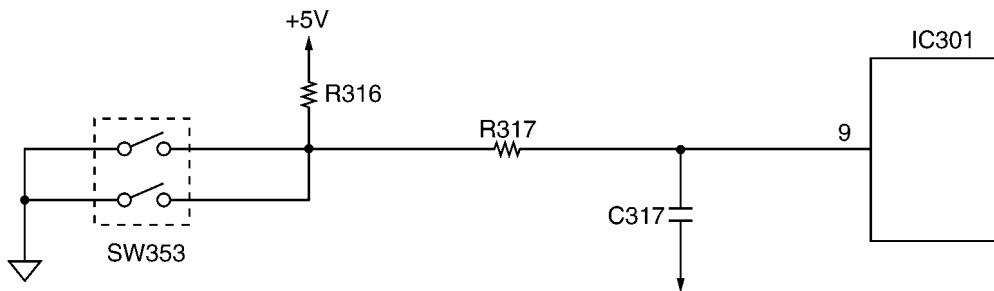

Operation Board		
	Photo transistor	Signal (IC301-9 pin)
No document	OFF	High level
Set document	ON	Low level

### 7.6.3. COVER OPEN SW (SW502)....."COVER OPEN "

When the operation panel cover is closed and a film is set, the SW becomes ON, and the input signal of IC520-36 pin (Digital) becomes a low level. When the cover is opened, the SW becomes OFF, and the input signal of IC520-36 pin (Digital) becomes a high level.

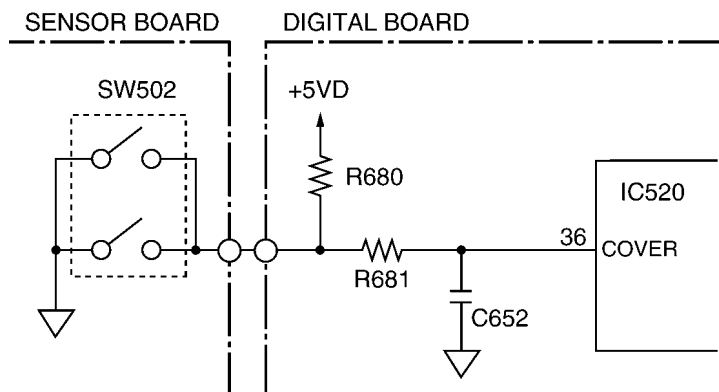

Sensor Board		
	SW	Signal (IC520-36 pin)
Cover open	OFF	High level
Cover closed	ON	Low level



### 7.6.4. HOOK SWITCH (SW101)

When the handset is lifted, the switch turns OFF, and the signal at pin 25 of IC501 becomes high.

When the handset is returned, the switch turns ON, and the signal at pin 25 of IC501 becomes low.

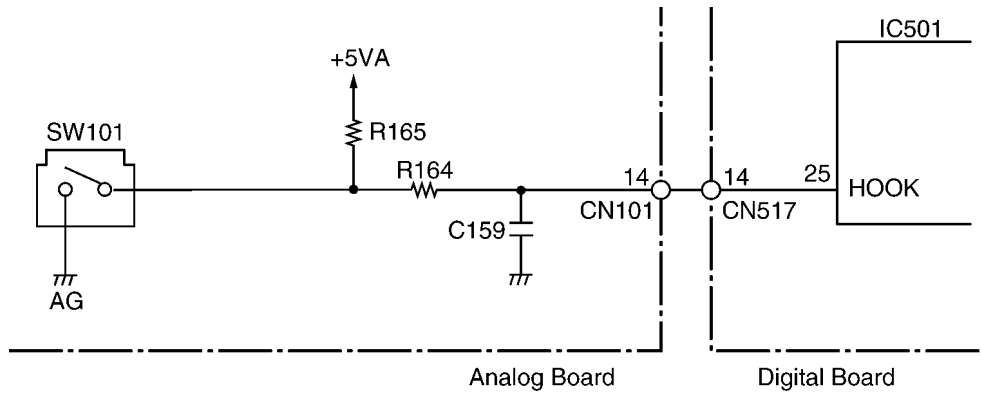

Digital Board		
	SW	Signal (IC501-25 pin)
ON-Hook	ON	Low level
OFF-Hook	OFF	High level

### 7.6.5. PAPER TOP SENSOR (PS501)....."PAPER JAMMED"

When the recording paper is loaded on the print head, the shelter plate shuts the sensor light, and the photo transistor turns OFF. The input signal of IC501-19 pin becomes a high level. Usually, the shelter plate is lifted, the photo transistor turns ON, and the input signal of IC501-19 pin becomes a low level.

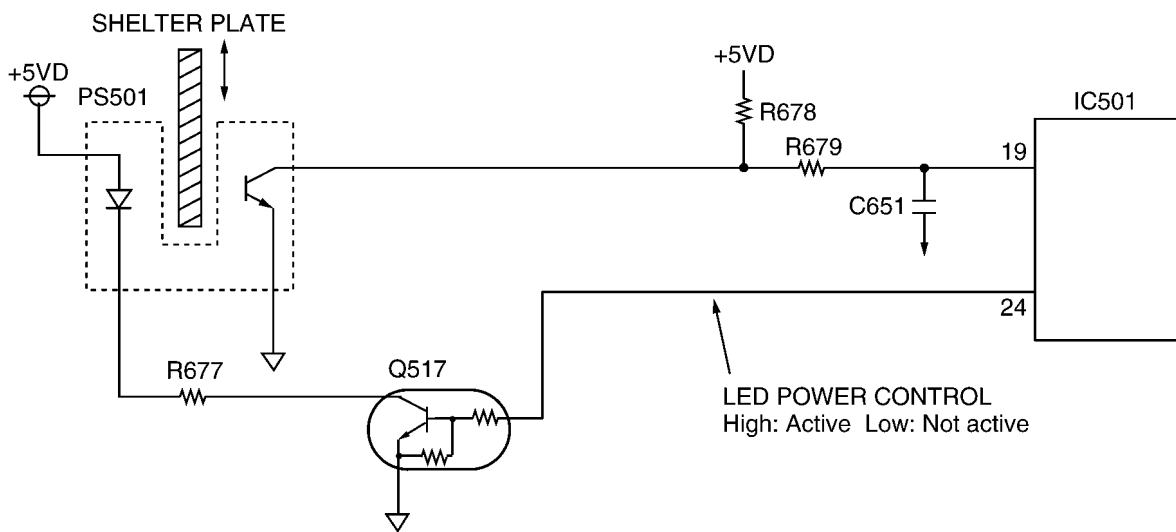

	Photo transistor	Signal (IC501-19 pin)
Recording paper top	OFF	High level
No recording paper	ON	Low level

## 7.7. MODEM SECTION

### 7.7.1. FUNCTION

The unit uses a 1 chip modem (IC505) that serves as an interface between the control section for FAX transmission and reception and the telephone line. During a transmitting operation, the digital image signals are modulated and sent to the telephone line.

During a receiving operation, the analog image signals which are received via the telephone line are demodulated and converted into digital image signals. The communication format and procedures for FAX communication are standardized by ITU-T. This 1 chip modem (IC505) has hardware which sends and detects all of the necessary signals for FAX communication.

It can be controlled by writing commands from the CPU (IC501: inside ASIC) to the register in the modem (IC505).

This modem (IC505) also sends DTMF signals, generates a call tone (from the speaker), and detects a busy tone and dial tones.

Overview of Facsimile Communication Procedures (ITU-T Recommendation):

#### 1. ON CCITT (International Telegraph and Telephone Consultative Committee)

The No. XIV Group of ITU-T, one of the four permanent organizations of the International Telecommunications Union (ITU), investigates and make recommendations on international standards for facsimiles.

#### 2. Definition of Each Group

- Group I (G1)

Official A-4 size documents without using formats which reduce the band width of a signal are sent over telephone lines. Determined in 1968.

Transmission for about 6 minutes at a scanning line density of 3.85 lines/mm.

- Group II (G2)

Using reduction technology in the modulation/demodulation format, an A-4 size document is sent at an official scanning line density of 3.85 lines/mm for about 3 minutes.

Methods to suppress redundancy are not used.

Determined in 1976.

- Group III (G3)

Method of suppressing redundancy in the image signal prior to modulation is used. An A-4 size document is sent within about one minute.

Determined in 1980.

- Group IV (G4)

Transmission is via the data network. A method is provided for suppressing redundancy in signals prior to transmission, and error-free reception of transmission is possible.

The scope of these facsimile applications is not limited simply to transmission of written statements. Through symbiotic linkages with other communication methods, it can be expected to expand to include integrated services.

### 3. Facsimile Call Time Series

#### Facsimile Call Time Series

As shown in the following diagram, the facsimile call time series is divided into five phases.

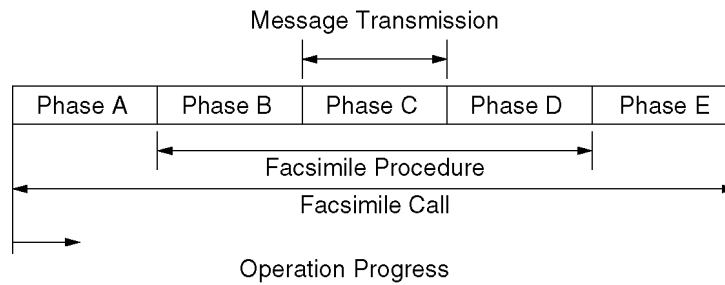

#### Phase A : Call setting

Call setting can be manual/automatic.

#### Phase B : Pre-message procedure

Phase B is a pre-processing procedure and sequence for confirming the status of the terminal, transmission route, etc., and for terminal control. It implements terminal preparation status, determines and displays terminal constants, confirms synchronization status, etc. and prepares for transmission of facsimile messages.

#### Phase C : Message transmission

Phase C is the procedure for the transmitting facsimile messages.

#### Phase D : Post message procedure

Phase D is the procedure for confirming that the message is completed and received. For continuous transmission, phase B or phase C is repeated for transmission.

#### Phase E : Call retrieval

Phase E is the procedure for call retrieval, that is for circuit disconnection.

### 4. Concerning Transmission Time

$$\boxed{\text{Transmission Time}} = \boxed{\text{Control Time}} + \boxed{\text{Image Transmission Time}} + \boxed{\text{Hold Time}}$$

Transmission time consists of the following.

#### Control time:

This is time at the start of transmission when the functions at the sending and receiving sides are confirmed, the transmission mode is established, and transmission and reception are synchronized.

#### Image transmission time:

This is the time required for the transmission of document contents (image data). In general, this time is recorded in the catalog, etc.

#### Hold time:

This is the time required after the document contents have been sent to confirm that the document was actually sent, and to check for telephone reservations and/or the existence of continuous transmission.

### 5. Facsimile Standards

Item	Telephone Network Facsimile
	G3 Machine
Connection Control Mode	Telephone Network Signal Mode
Terminal Control Mode	T. 30 Binary
Facsimile Signal Format	Digital
Modulation Mode	PSK (V. 27 ter) or QAM (V. 29)
Transmission Speed	300 bps (Control Signal) 2400, 4800, 7200, 9600 bps (FAX Signal)
Redundancy Compression Process (Coding Mode)	1 dimension : MH Mode 2 dimension : MR Mode (K=2.4)
Resolution	Main Scan : 8 pel/mm Sub Scan : 3.85, 7.7l/mm
Line Synchronization Signal	EOL Signal
1 Line Transmission Time [ms/line]	Depends on the degree of data reduction. Minimum Value : 10, 20 Can be recognized in 40ms.

## 6. Explanation of Communication and Compression Technology

### a. G3 Communication Signals (T. 30 Binary Process)

For G3 Facsimile communication, this is the procedure for exchanging control signals between the sending and receiving machines both before and after transmission of image signals.

Control signals at 300 bps FSK are: 1850 Hz...0, 1650Hz...1.

An example of a binary process in G3 communication is shown below.

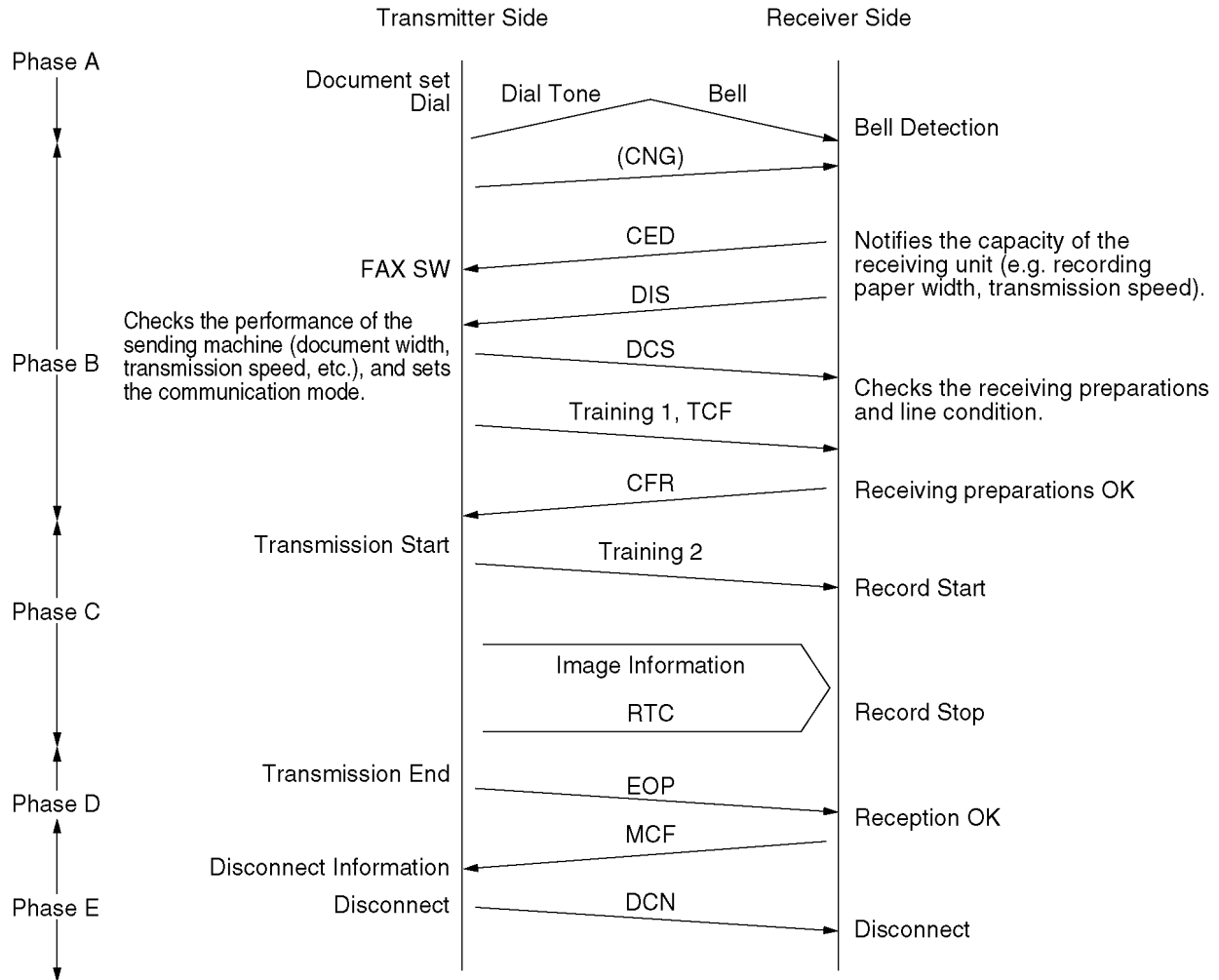

#### Explanation of Signals

Control signals are comprised mainly of 8-bit identification signals and the data signals added to them. Data signals are added to DIS and DCS signals.

Signal.....DIS (Digital Identification Signal)

Identification Signal Format.....00000001

#### Function:

Notifies the capacity of the receiving unit. The added data signals are as follows.

Signal.....DCS (Digital Command Signal)

Identification Signal Format.....X1000001

**Example** (Some models do not support the following items.):

Bit No.	DIS/DTC	DCS
1	Transmitter --- T.2 operation	
2	Receiver --- T.2 operation	Receiver --- T.2 operation
3	T.2 IOC = 176	T.2 IOC = 176
4	Transmitter --- T.3 operation	
5	Receiver --- T.3 operation	Receiver --- T.3 operation
6	Reserved for future T.3 operation features	

Bit No.	DIS/DTC	DCS
7	Reserved for future T.3 operation features.	
8	Reserved for future T.3 operation features.	
9	Transmitter --- T.4 operation	
10	Receiver --- T.4 operation	Receiver --- T.4 operation
11, 12, 13, 14 0, 0, 0, 0 0, 1, 0, 0 1, 0, 0, 0 1, 1, 0, 0 0, 0, 1, 0 0, 1, 1, 0 1, 0, 1, 0 1, 1, 1, 0 0, 0, 0, 1 0, 1, 0, 1 1, 0, 0, 1 1, 1, 0, 1 0, 0, 1, 1 0, 1, 1, 1 1, 0, 1, 1 1, 1, 1, 1	Data signaling rate V.27 ter fall back mode V.27 ter V.29 V.27 ter and V.29 Not used Reserved Not used V.27 ter and V.29 and V.33 Not used Reserved Not used V.27 ter and V.29 and V.33 and V.17 Not used Reserved Reserved Not used Reserved	Data signaling rate 2400 bit/s, V.27 ter 4800 bit/s, V.27 ter 9600 bit/s, V.29 7200 bit/s, V.29 14400 bit/s, V.33 12000 bit/s, V.33 Reserved Reserved 14400 bit/s, V.17 12000 bit/s, V.17 9600 bit/s, V.17 7200 bit/s, V.17 Reserved Reserved Reserved Reserved
15	R8x7.7 lines/mm and/or 200x200 pels/25.4mm	R8x7.7 lines/mm and/or 200x200 pels/25.4mm
16	Two-dimensional coding capability	Two-dimensional coding capability
17, 18 (0, 0) (0, 1) (1, 0) (1, 1)	Recording width capabilities 1728 picture elements along scan line length of 215 mm ± 1% 1728 picture elements along scan line length of 215 mm ± 1% 2048 picture elements along scan line length of 255 mm ± 1% 2432 picture elements along scan line length of 303 mm ± 1% 1728 picture elements along scan line length of 215 mm ± 1% 2048 picture elements along scan line length of 255 mm ± 1% Invalid	Recording width 1728 picture elements along scan line length of 215 mm ± 1% 2432 picture elements along scan line length of 303 mm ± 1% 2048 picture elements along scan line length of 255 mm ± 1% Invalid
19, 20 (0, 0) (0, 1) (1, 0) (1, 1)	Maximum recording length capability A4 (297 mm) Unlimited A4 (297 mm) and B4 (364 mm) Invalid	Maximum recording length A4 (297 mm) Unlimited B4 (364 mm) Invalid
21, 22, 23 (0, 0, 0) (0, 0, 1) (0, 1, 0) (1, 0, 0) (0, 1, 1) (1, 1, 0) (1, 0, 1) (1, 1, 1)	Minimum scan line time capability of the receiver 20 ms at 3.85 l/mm: $T_{7.7} = T_{3.85}$ 40 ms at 3.85 l/mm: $T_{7.7} = T_{3.85}$ 10 ms at 3.85 l/mm: $T_{7.7} = T_{3.85}$ 5 ms at 3.85 l/mm: $T_{7.7} = T_{3.85}$ 10 ms at 3.85 l/mm: $T_{7.7} = 1/2 T_{3.85}$ 20 ms at 3.85 l/mm: $T_{7.7} = 1/2 T_{3.85}$ 40 ms at 3.85 l/mm: $T_{7.7} = 1/2 T_{3.85}$ 0 ms at 3.85 l/mm: $T_{7.7} = T_{3.85}$	Minimum scan line time 20 ms 40 ms 10 ms 5 ms    0 ms
24	Extend field	Extend field
25	2400 bit/s handshaking	2400 bit/s handshaking
26	Uncompressed mode	Uncompressed mode
27	Error correction mode	Error correction mode
28	Set to "0".	Frame size 0 = 256 octets 1 = 64 octets
29	Error limiting mode	Error limiting mode
30	Reserved for G4 capability on PSTN	Reserved for G4 capability on PSTN
31	T.6 coding capability	T.6 coding enabled
32	Extend field	Extend field
33 (0) (1)	Validity of bits 17, 18 Bits 17, 18 are valid Bits 17, 18 are invalid	Recording width Recording width indicated by bits 17, 18 Recording width indicated by this field bit information
34	Recording width capability 1216 picture elements along scan line length of 151 ± mm 1%	Middle 1216 elements of 1728 picture elements
35	Recording width capability 864 picture elements along scan line length of 107 ± mm 1%	Middle 864 elements of 1728 picture elements
36	Recording width capability 1728 picture elements along scan line length of 151 ± mm 1%	Invalid
37	Recording width capability 1728 picture elements along scan line length of 107 ± mm 1%	Invalid
38	Reserved for future recording width capability.	
39	Reserved for future recording width capability.	
40	Extend field	Extend field

Bit No.	DIS/DTC	DCS
41	R8×15.4 lines/mm	R8×15.4 lines/mm
42	300×300 pels/25.4 mm	300×300 pels/25.4 mm
43	R16×15.4 lines/mm and/or 400×400 pels/25.4 mm	R16×15.4 lines/mm and/or 400×400 pels/25.4 mm
44	Inch based resolution preferred	Resolution type selection "0" : neuritic based resolution "1" : inch based resolution
45	Metric based resolution preferred	Don't care
46	Minimum scan line time capability for higher resolutions "0" : $T_{15.4} = T_{7.7}$ "1" : $T_{15.4} = 1/2T_{7.7}$	Don't care
47	Selective Polling capability	Set to "0".
48	Extend field	Extend field

Note 1 - Standard facsimile units conforming to T.2 must have the following capability : Index of cooperation (IOC)=264.

Note 2 - Standard facsimile units conforming to T.3 must have the following capability : Index of cooperation (IOC)=264.

Note 3 - Standard facsimile units conforming to T.4 must have the following capability : Paper length=297 mm.

Signal	Identification Signal Format	Function
Training 1	_____	A fixed pattern is transmitted to the receiving side at a speed (2400 to 9600 bps) designated by DCS, and the receiving side optimizes the automatic equalizer, etc., according to this signal.
TCF (Training Check)	_____	Sends 0 continuously for 1.5 seconds at the same speed as the training signal.
CFR (Confirmation to Receive)	X0100001	Notifies the sending side that TCF has been properly received. If TCF is not properly received, FTT (Failure To Train) X0100010 is relayed to the sender. The sender then reduces the transmission speed by one stage and initiates training once again.
Training 2	_____	Used for reconfirming the receiving side like training 1.
Image Signal	Refer to the next page.	_____
RTC (Return to Control)	_____	Sends 12 bits (0...01 × 6 times) to the receiver at the same speed as the image signal and notifies completion of transmission of the first sheet.
EOP (End of Procedure)	X1110100	End of one communication
MCF (Message Confirmation)	X0110001	End of 1 page reception
DCN (Disconnect)	X1011111	Phase E starts.
MPS (Multi-Page Signal)	X1110010	Completion of transmission of 1 page. If there are still more documents to be sent, they are output instead of EOP. After MCF reception, the sender transmits an image signal of the second sheet.
PRI-EOP (Procedural Interrupt-EOP)	X1111100	If there is an operator call from the sender, it is output after RTC.
PIP (Procedural Interrupt Positive)	X0110101	This is output when an operator call is received.

**b. Redundancy Compression Process Coding Mode**

This unit uses one-dimensional MH format.

(a) Document

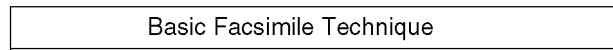

(b) Part of document



(c) Run length and image signals equivalent to (b)

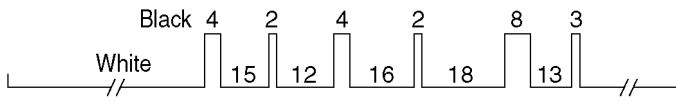

Modified Huffman (MH) Code		
Run length	Code for White Line	Code for Black Line
0	00110101	000011011
1	000111	010
2	0111	11
3	1000	10
4	1011	011
5	1100	0011
6	1110	0010
7	1111	00011
8	10011	000101
9	10100	000100
10	00111	0000100
11	01000	0000101
12	001000	0000111
13	000011	00000100
14	110100	00000111
15	110101	000011000
16	101010	0000010111
17	101011	0000011000
18	0100111	0000001000

(d) Codification of (c) according to MH formula

00110111101010 (White 400)    011 (Black 4)    110101 (White 15)    11 (Black 2)    001000 (White 12)    011 (Black 4)    101010 (White 16)

11 (Black 2)    0100111 (White 18)    000101 (Black 8)    000011 (White 13)    10 (Black 3)

(c) Total bit number before MH codification (497 bit)

(d) Total bit number after MH codification (63 bit)

## 7.7.2. MODEM CIRCUIT OPERATION

The modem (IC505) has all the hardware satisfying the ITU-T standards mentioned previously.

When the ASIC IC501 (61) is brought to a low level, the modem (IC505) is chip-selected and the resistors inside IC are selected by the select signals from ASIC (IC501) ADR0-ADR4 (pin 81~85). Commands are written through the data bus, and all processing is controlled by the ASIC (IC501) according to ITU-T procedures. Here, the INT signal dispatched from IRQ (pins 108 and 121 of IC505) to the ASIC (IC501) implements post processing.

This modem (IC505) has an automatic application equalizer. With training signal 1 or 2 at the time of G3 reception, it can automatically establish the optimum equalizer. The modem (IC505) clock is supplied by X503.

### 1. Facsimile Transmission/DTMF Line Send

The digital image data on the data bus is modulated in the modem (IC505), and sent from pin 69, Analog SW IC509(1→2), amplifier IC511(2→1) and the NCU section to the telephone line.

Refer to **CHECK SHEET** (P.105).

### 2. Facsimile Reception

The analog image data which is received from the telephone line passes through the NCU section and enters pin 60 of the modem (IC505). The signals that enter pin 60 of the modem (IC505) are demodulated in the board to digital image signals, then placed on the data bus.

In this case, the image signals from the telephone line are transmitted serially. Hence, they are placed on the bus in 8 bit units. Here, the internal equalizer circuit reduces the image signals to a long-distance receiving level.

This is designed to correct the characteristics of the frequency band centered around 3 kHz and maintain a constant receiving sensitivity.

It can be set in the service mode.

Refer to **CHECK SHEET** (P.105).

### 3. DTMF Transmission (Monitor tone)

The DTMF signal generated in the modem (IC505) is output from pin 69, and the NCU section to the telephone line the same as facsimile transmission signals.

#### (DTMF Monitor Tone)

Refer to **CHECK SHEET** (P.105).

### 4. Busy/Dial Tone Detection

The path is the same as FAX receiving. When it is detected, the carrier detect bit of the resistor in the modem (IC505) becomes 1, and this status is monitored by ASIC (IC501).



## 7.8. ANALOG SECTION

### 1. Function

The analog section serves as an interface between the telephone line. The digital board (IC505) for transmission and reception of FAX signals, switches between the digital board (IC505) and other sections by means of a multiplexer in the NCU section. The control signals to the individual analog sections are output mainly from ASIC IC501, and the status information for the various sections is also held in ASIC IC501.

Simple explanations for the various sections are given below.

### 2. Circuit Operation

#### [NCU Section]

This is the interface between the telephone line and external telephone. This is composed of a bell detection circuit, pulse dial generation circuit, EXT. TAM OFF-HOOK detect circuit, vox circuit, amplifier circuit for line transmission and reception, sidetone circuit, etc.

#### [Modem (IC505)]

This is used for FAX signal tone modulation, DTMF signal transmission. The DTMF signal is placed into the TX system.

### 7.8.1. ANALOG UNIT BLOCK DIAGRAM

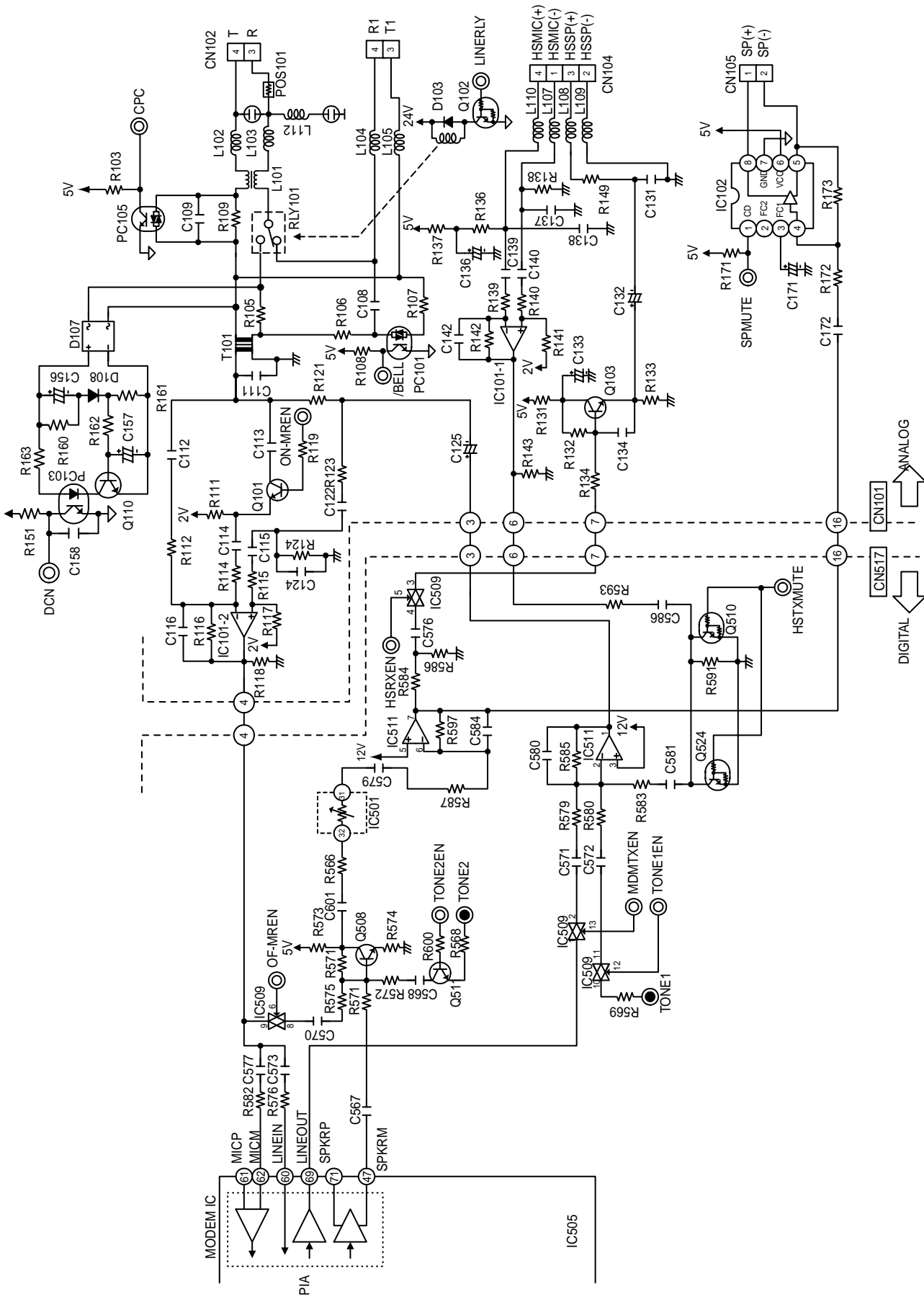

KX-FP342BX : ANALOG BOARD BLOCK DIAGRAM

## 7.9. NCU SECTION

### 7.9.1. GENERAL

This section is the interface between the telephone line and external telephone. It is composed of an EXT. TEL line relay (RLY101), bell detection circuit, pulse dial circuit, TAM interface circuit, line amplifier and sidetone circuits and a multiplexer.

### 7.9.2. EXT. TEL. LINE RELAY (RLY101)

#### 1. Circuit Operation

Normally, this relay switches to the external telephone side (break) and switches to the open side (make) while OFF-HOOK.

{ IC501 (138) High Level → CN517 (12) High Level } → CN101 (12) High Level → Q102 ON → RLY101 (make)

### 7.9.3. BELL DETECTION CIRCUIT

#### 1. Circuit Operation

The signal waveform for each point is indicated below. The signal (low level section) input to pin 42 of ASIC IC501 on the digital board is read by ASIC and judged as a bell.

TEL LINE → PC101 (1, 2 - 4) → IC501 (42)

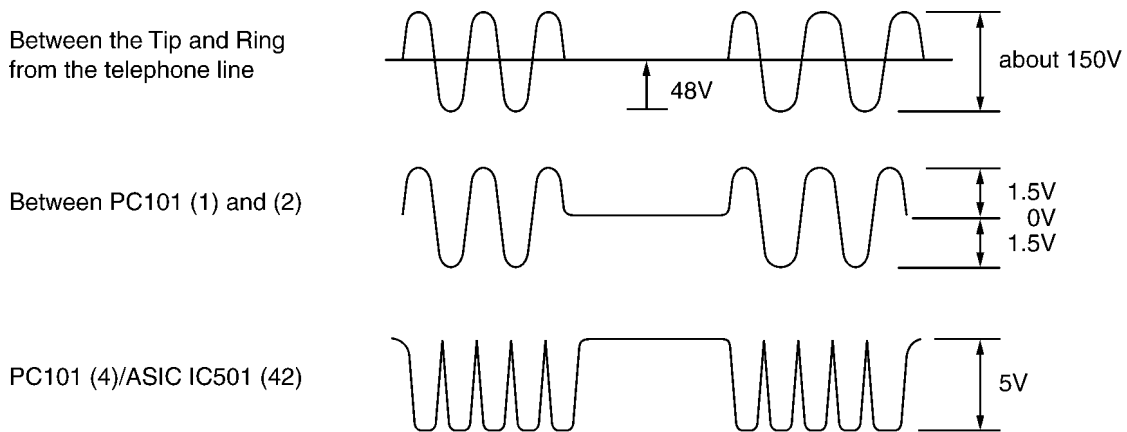

### 7.9.4. TAM INTERFACE CIRCUIT

This circuit is to switch between FAX receiving and the external TAM's message recording automatically. This circuit consists of an EXT. TAM OFF-HOOK detect circuit, monitor transformer, multiplexer, amplifier, and VOX detect circuit.

For details, please refer to **TAM INTERFACE SECTION** (P.152).

### 7.9.5. PULSE DIAL CIRCUIT AND ON / OFF HOOK CIRCUIT

While OFF-HOOK, RLY101 is ON. Q102 turns on by pin (138) of IC501 as well. On the other hand, while ON-HOOK, Q102 turns OFF by pin (138) of IC501, then the line turns OFF. ON/OFF-HOOK, controlled by pin (138) of IC501, makes the pulse dial operation possible.

IC501 (138) LINE RLY Low Level → CN517 (12) → CN101 (12) → Q102 OFF → RLY101 OFF : DC Loop OFF

IC501 (138) LINE RLY High Level → CN517 (12) → CN101 (12) → Q102 ON → RLY101 ON : DC Loop ON

## 7.9.6. LINE AMPLIFIER AND SIDE TONE CIRCUIT

### 1. Circuit Operation

The reception signal output from the line transformer T101 is input to pin (2) of IC101 via C112 and R112 and then the signal is amplified at pin (1) of IC101 and sent to the reception system at 11.6dB.

The transmission signal goes through C571 and R579 and enters IC511-pin (2), where the signal is amplified to about 24.8dB. Then, it is output from pin (1) of IC101 and transmitted to T101 via C125 and R121. If the side tone circuit is not applied, the transmission signal will return to the reception amplifier via C112 and R112. When the side tone circuit is active, the signal output from IC101 pin (1) passes through C125, R123, C122, C115 and R115 and goes into the amplifier IC101 pin (3). This circuit is used to cancel the transmission return signal.

### Side Tone Circuit

Transmission Signal: C571 → R579 → IC511 (2)(1) → CN517(3) → CN101(3) → C125 → R121 → T101 → Telephone Line

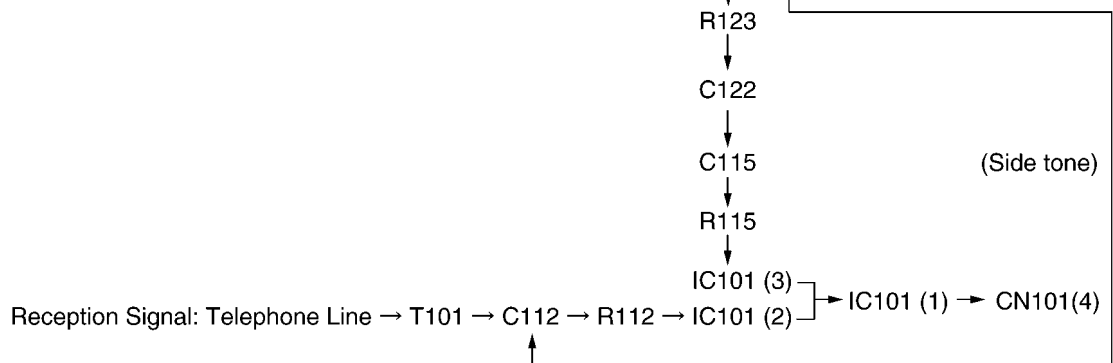

### 7.9.7. CALLING LINE IDENTIFICATION CIRCUIT

#### 1. Function

This unit is compatible with the Caller ID service offered by your local telephone company. To use this feature, you must subscribe to a Caller ID service. The data for the caller ID from the telephone exchange is sent during the interval between the first and second rings of the bell signal. The data from the telephone exchange is a modem signal which is modulated in an FSK (Frequency Shift Keying) format. Data "0" is a 1200 Hz sine wave, and data 1 a 2200 Hz sine wave.

There are two type of the message format which can be received:i.e.the single data message format and multiple data message format.

The multiple data format allows to transmit the name and data code information in addition to the time and telephone number data.

When there is multiple data in the unit, the name or telephone number are displayed.

#### 2. Circuit Operation:

The caller ID signal input from TEL LINE is processed with MODEM (IC505).

Refer to **CHECK SHEET** (P.105) for the route of caller ID signal.

**Timing Chart**

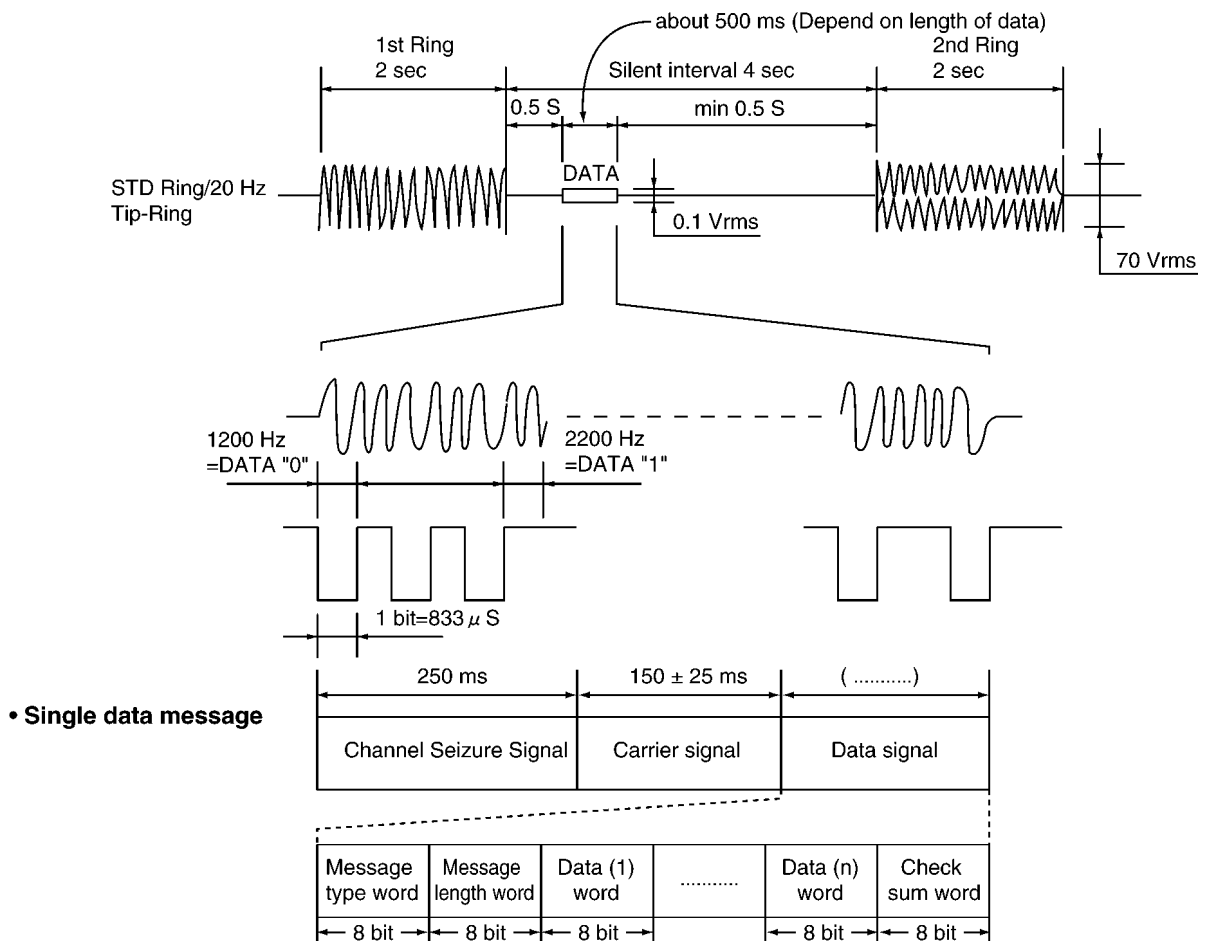

- 1 word = All 8 bit data
- Message Type Word = Fixed value "00000100"
- Message Length Word = number of the data word
- Data word = The data value (month, day, hour, minute, telephone number)

• Multiple data message

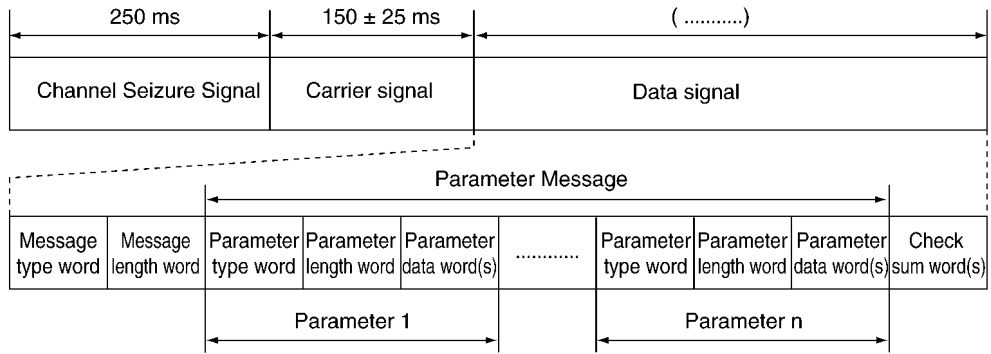

- 1 word = All 8 bit data
- Message Type = Fixed value "10000000"
- Message Length Word = number of the Parameter Message word
- Parameter Type Word = Kind of data (ex. the time, phone number)
- Parameter Length Word = number of the Parameter data word
- Parameter Word (s) = the data value

## 7.10. ITS (Integrated Telephone System) AND MONITOR SECTION

### 7.10.1. GENERAL

During the monitor operation, the speaker output passes through the power amplifier (IC102) [Analog board].

The DTMF signal is output from the modem (IC505: digital board). The alarm tone, the key tone, bell tone, and beep are output from gate array IC501 (digital board). During a pulse dial operation, the monitor tone is output from gate array IC501.

### 7.10.2. TELEPHONE MONITOR

#### 1. Function

This is the function when you are not holding the handset and can hear the caller's voice from the line.

#### 2. Signal path

Refer to **CHECK SHEET** (P.105).

### 7.10.3. HANDSET CIRCUIT

#### 1. Function

This circuit controls the conversation over the handset, i.e. the transmitted and received voices to and from the handset.

#### 2. Signal path (Transmission signal)

Refer to **CHECK SHEET** (P.105).

#### 3. Signal path (Reception signal)

Refer to **CHECK SHEET** (P.105).

### 7.10.4. MONITOR CIRCUIT

#### 1. Function

This circuit monitors various tones, such as 1 DTMF tone, 2 Alarm/Beep/Key tone/Bell.

#### 2. Signal path

##### a. DTMF MONITOR

(Speaker Operation)

Refer to **CHECK SHEET** (P.105).

(Handset Operation)

Refer to **CHECK SHEET** (P.105).

##### b. ALARM/BEEP/KEY TONE/BELL

Refer to **CHECK SHEET** (P.105).

## 7.11. TAM INTERFACE SECTION

### 7.11.1. FUNCTION

If EXT. TAM is selected in the Receive mode, the unit receives documents for FAX calls or the external TAM records a voice message automatically.

To switch between the answering machine and facsimile in the EXT. TAM Mode.

#	EXTERNAL TAM OPERATION	UNIT OPERATION
1	When the bell signal rings as many times as the number memorized into the connected answering machine (TAM), the answering machine is connected to the line and the answering message is sent out to the line. (OGM out for 8 ~ 16 sec.)	The length of the answering message should be 8~16 seconds. While the message is being played, the unit starts to detect the CNG signal.(A) If the unit detects the CNG signal, it will switch to FAX receiving and disconnect the external TAM automatically.
2	After sending the OGM, the answering machine starts to record the message of the other party (ICM recording).	After the OGM of the external TAM is finished, the unit starts to detect approximately 5 seconds of no sound detection. (B) If no sound is detected, the unit will switch to FAX receiving and disconnect the external TAM automatically. If the unit cannot detect the CNG signal or no sound for about 30 seconds, the unit will disconnect the line. (C)

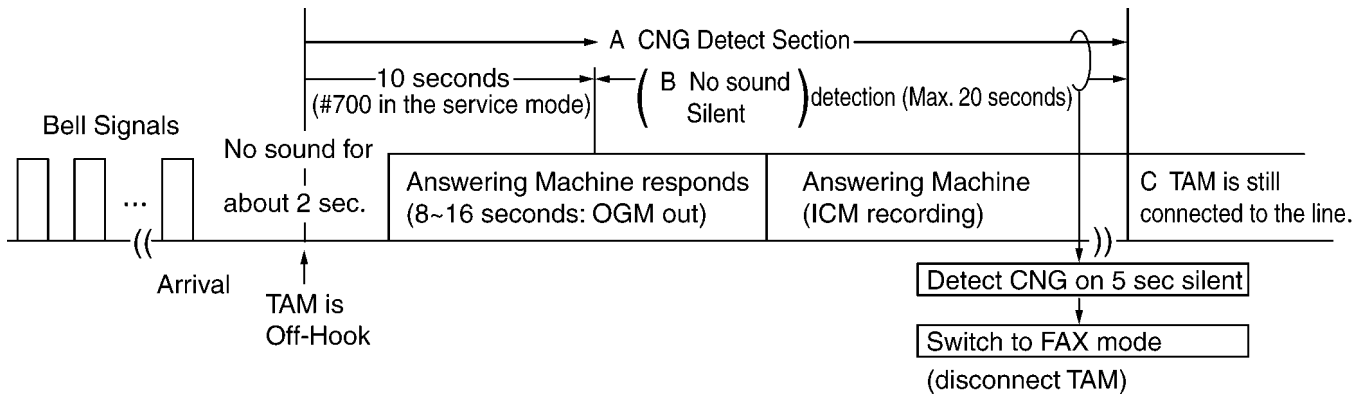

**Attention 1:**

No sound detection lasts 20 seconds after the telephone call is received at the answering machine. If there is no sound for more than 5 seconds (#701 in the service mode), it switches to the facsimile.

**Attention 2:**

When the answering machine cannot answer the telephone call because of disconnection or the recording tape is full, the unit picks up the call after 5 rings (#006 in the feature). Then it switches to the facsimile.



## 7.11.2. CIRCUIT OPERATION

The TAM INTERFACE circuit consists of an EXT. TAM HOOK detection circuit, CNG signal from the other party's detection circuit, VOX detection circuit (to judge sound/no-sound) and RLY101 (to separate EXT. TAM).

### 1. EXT. TAM HOOK detection circuit

A bell is received at EXT. TAM and EXT. TAM is connected to the line, making a DC LOOP. Then, PC105 detects this voltage. During detection, PC105 (4) becomes low.

(DC LOOP)

Tip → L102 → PC105 (2, 1) → L105 → Tip1 → (EXT.TAM) → Ring 1 → L104 → RLY101(5, 3) → L103 → POS101 → Ring

### 2. CNG/VOX signal detection circuit

The CNG signal from the other party's FAX is detected in MODEM IC505 (digital board).

(Signal path)

Refer to **CHECK SHEET** (P.105).

### 3. Remote receiving

This is the parallel-connected DTMF signal for the TEL or EXT.TEL mode between T and R. When the other party is a FAX, the unit switches to FAX receiving.

(Signal Path)

Detects the DTMF signal in the MODEM.

## 7.12. OPERATION BOARD SECTION

The unit consists of a LCD (Liquid crystal display), KEYS and LEDs (light-emitting diodes). They are controlled by the Gate Array (IC301) and ASIC (IC501: on the DIGITAL BOARD).

The key matrix table is shown below.

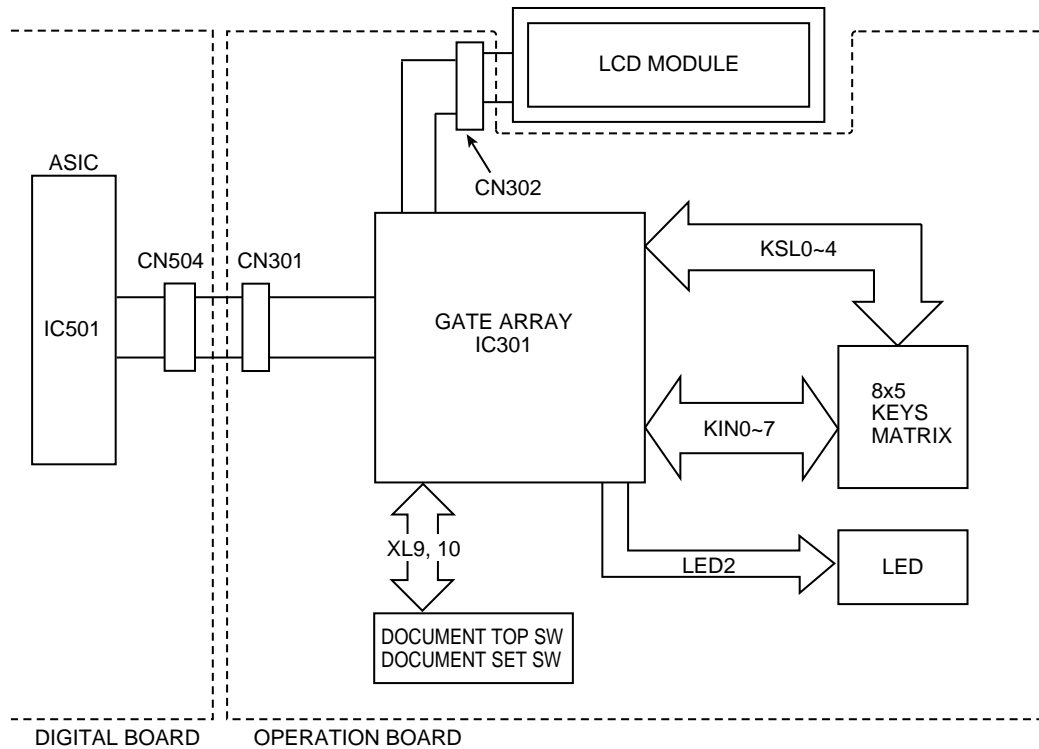

KX-FP342BX:OPERATION BOARD BLOCK DIAGRAM

### Key Matrix

	KIN0	KIN1	KIN2	KIN3	KIN4	KIN5	KIN6	KIN7
KSL0	SW301 FAX / START / SET	SW304 1	SW309 2	SW314 3	SW319 COPY		SW328 HELP	SW333 SEARCH
KSL1	SW302 MONITOR	SW305 4	SW310 5	SW315 6	SW320 STOP		SW329 RECEIVE MODE	SW334 JUNK FAX PROHIBITOR
KSL2		SW306 ✳	SW311 0	SW316 #	SW321 PREV	SW326 MENU	SW330 S5	SW335 S2
KSL3	SW303 VOL (-)	SW307 FLASH	SW312 REDIAL/PAUSE	SW317 HANDSET MUTE	SW322 NEXT		SW331 LOWER	SW336 S3
KSL4		SW308 7	SW313 8	SW318 9		SW327 VOL(+)	SW332 S4	SW337 S1

### XL

	XL10	XL9
	DOCUMENT SET	DOCUMENT TOP

### LED

JUNK FAX PROHIBITOR LED ON/OFF port.....LED2 (IC301-36)

### 7.13. LCD SECTION

The Gate Array (IC301) works only for writing the ASCII code from the data bus (D4~D7). V0 is supplied for the crystal drive. R303, R305, and R306 are density control resistors.

Consequently, in this unit, the timing (positive clock) is generated by the LCD interface circuitry in the gate array (IC301).

#### Circuit Diagram

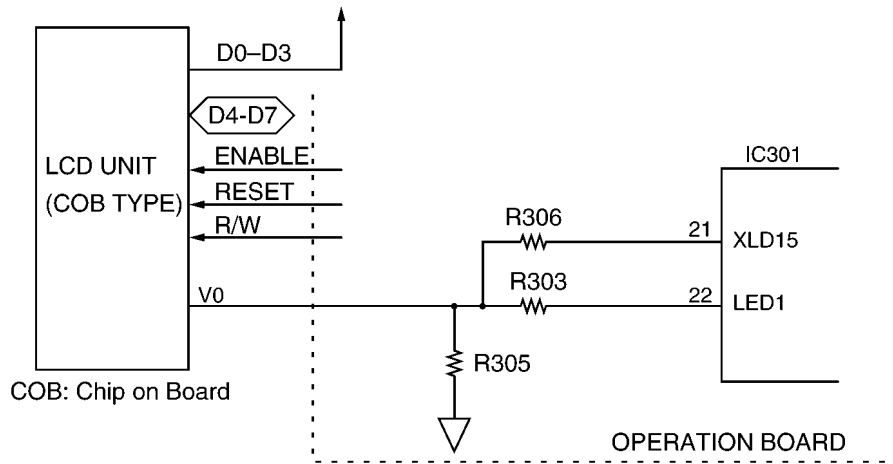

#### Timing Chart

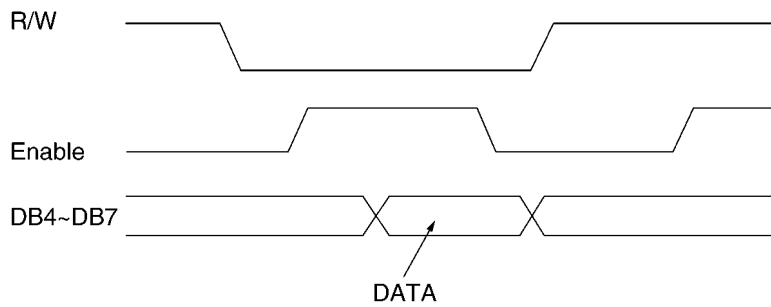

Display mode	Density	Normal	Darker
2 lines (X1.0)	LED1 (IC301-22pin)	H	L
	XLD15 (IC301-21pin)	L	L
X1.5	LED1	H	H
	XLD15	Hi-Z	L

## 7.14. POWER SUPPLY BOARD SECTION

This power supply board uses the switching regulator method.

### Block Diagram

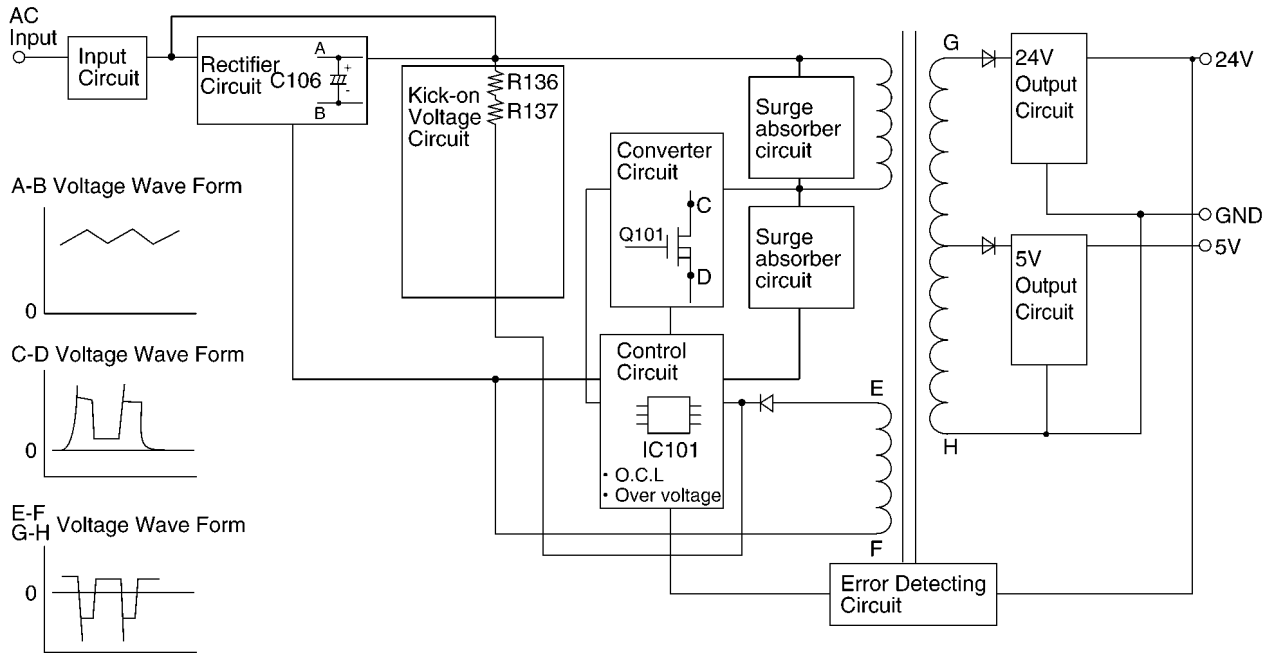

#### [Input Circuit]

The input current goes into the input rectifier circuit through the filter circuit. The filter circuit decreases the noise voltage and the noise electric field strength.

#### [Rectifier Circuit]

The input current is rectified by D101~ D104 and charges C106 to make DC voltage. Then it supplies power to the converter circuit.

#### [Kick-on voltage circuit]

Bias is applied to the Q101 gate via this circuit when the AC power is turned on and Q101 begins operating.

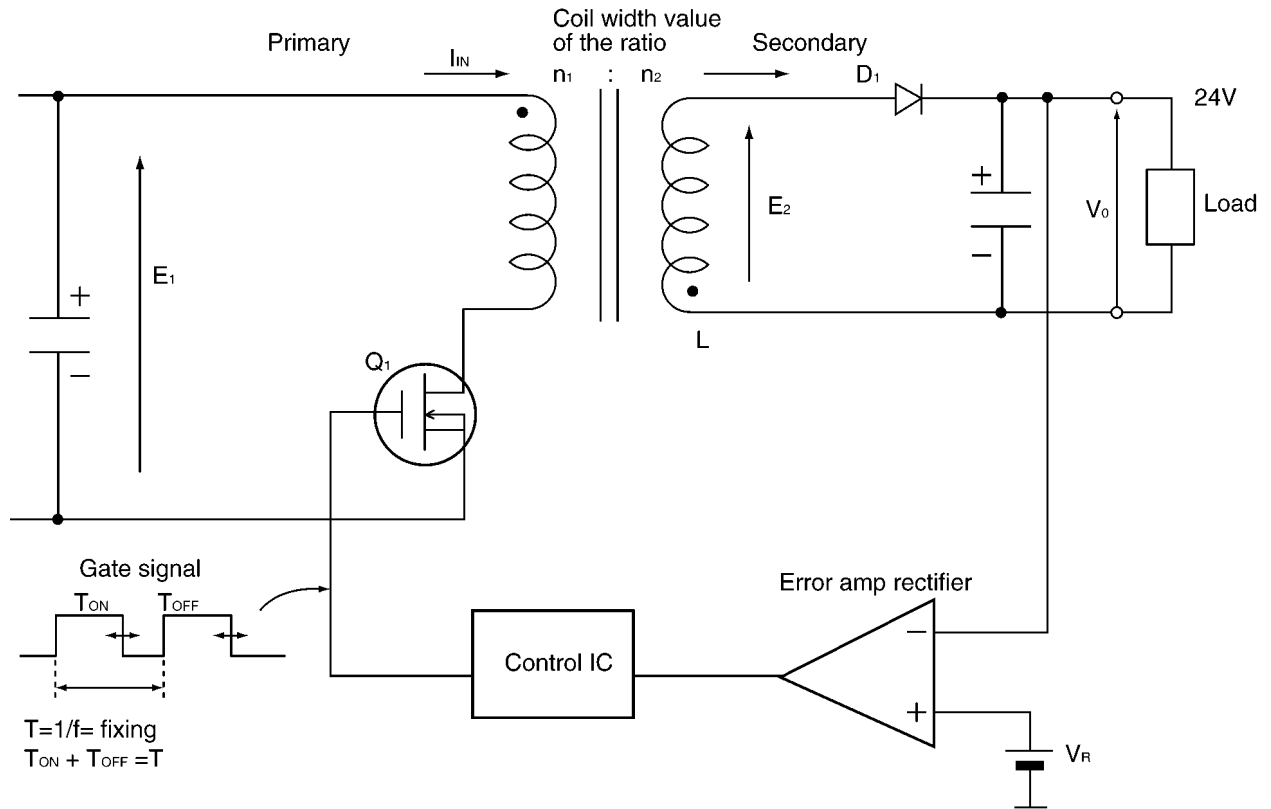

The following is an overview of how the power supply unit is controlled.  
 The control method of this power supply unit is pulse width modulation.

When  $Q_1$  is ON, the energy is charged in the transfer primary coil according to  $E_1$ . When  $Q_1$  is OFF, the energy is output from the secondary transfer as follows.

$L \rightarrow D_1 \rightarrow \text{Load} \rightarrow L$

Then the power is supplied to the Load. When  $Q_1$  is ON, power is not output from the secondary side. The output voltage is fed back in the control IC according to the error amp rectifier. Then depending on how  $T_{ON}$  is controlled, stabilization occurs. Also, when the current load becomes too large, in order to decrease the voltage output, the increase in  $\tau$  is controlled and the output voltage is stabilized.

Therefore, basically the timing:  $T_{on}/T_{off}$  of  $Q_1$  controls the output voltage.

Output/Input voltage value of ratio

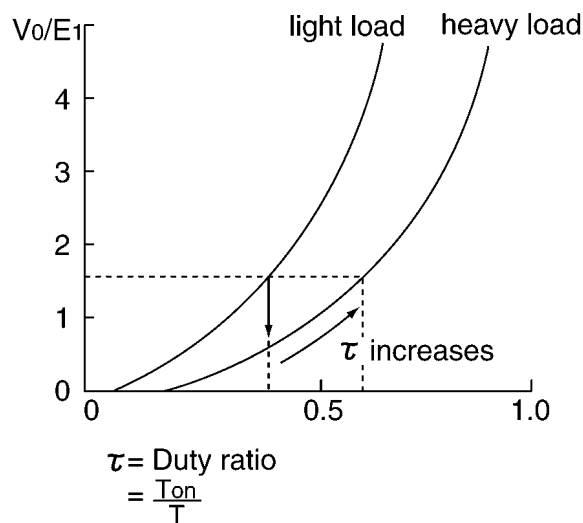

**[Surge Absorber Circuit]**

This circuit is for absorbing surge voltage generated by the transformer.

**[Control Circuit and Detecting Circuit]**

The control circuit amplifies the output with increased voltage detected in the error detecting circuit. Then it drives the main transistor.

In this power supply, the duty ratio is defined by changing the ON period of the main transistor.

This is shown as follows.

When the output voltage of the 24V circuit increases, the current of the photo coupler PC101 increases, the pulse width of the output control IC becomes narrower and the ON period of Q101 becomes shorter.

**[Over Current Limiter (O.C.L)]**

The highest drain current (Q101) is limited by a limiter circuit (IC101) of 24V. The 24V output is limited by this circuit.

**[Over Voltage Circuit]**

If the 24V output increases because the error detecting circuit or control circuit is broken, IC101 will recognize this signal and output becomes 0V.

**Dummy load method (to quickly check the power supply output)**

Refer to **POWER SUPPLY BOARD SECTION** (P.108).

# 8 REFERENCE MATERIAL DATA

## 8.1. TERMINAL GUIDE OF THE ICs TRANSISTORS AND DIODES

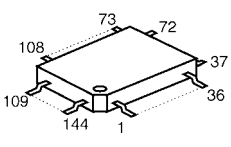
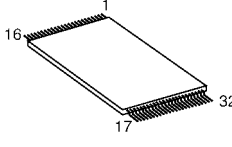
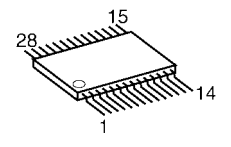
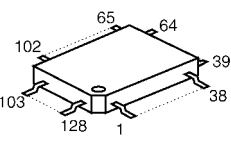
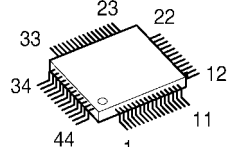
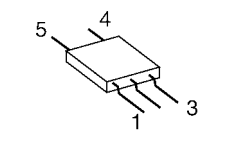
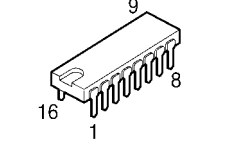
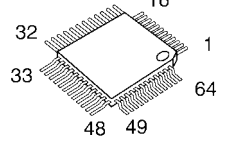
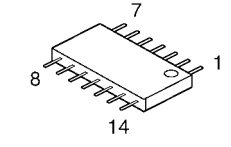
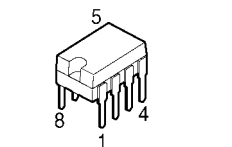
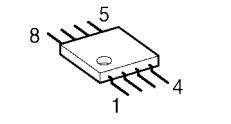
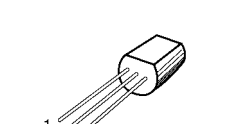
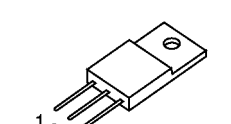
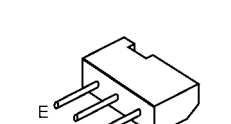
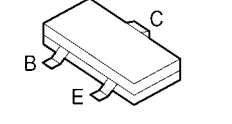
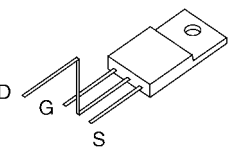
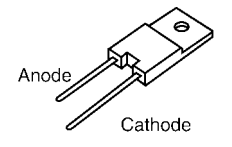
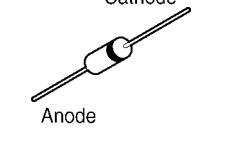
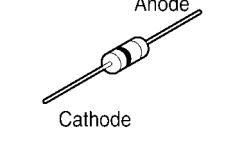
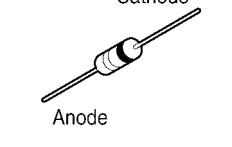
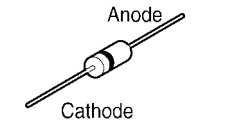
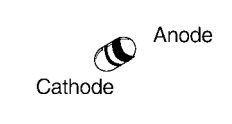
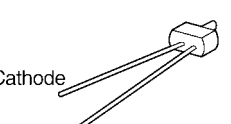
 <p>C1ZBZ0001896</p>	 <p>PFWIFP342BX</p>	 <p>PFVIMS5148EF</p>	 <p>PFVIR676812</p>	 <p>MN7D032Z9J</p>
 <p>PFVII5510011</p>	 <p>PFVIT2003APS</p>	 <p>C1ZBZ0002029</p>	 <p>PQVITC4066BF</p>	 <p>PFVIFA5317P</p>
 <p>PQVIMC34119M PFVINJM4558M PQVINJM2904F PFVTSI4431DY</p>	 <p>AN1431T</p>	 <p>AN7805F</p>	 <p>2SB1322</p>	 <p>PQVTDTC143E PQVTDTC114EU 2SB1218A, 2SD1819A UN5113</p>
 <p>PFVTF510KM10</p>	 <p>PFVDSF5LC20U</p>	 <p>1SS119</p>	 <p>MA7160, PFVD1N4005 MA4220, PFVDD1NL20U</p>	 <p>PFVDRMRLS245 MA4056</p>
 <p>PQVDERA1802 PFVDEG01C, MA165</p>	 <p>RLS71</p>	 <p>PQVDSL325MC</p>		

## 8.2. HOW TO REPLACE THE FLAT PACKAGE IC

Even if you do not have the special tools (for example, a spot heater) to remove the Flat IC, with some solder (large amount), a soldering iron and a cutter knife, you can easily remove the ICs that have more than 100 pins.

### 8.2.1. PREPARATION

#### 8.2.1.1. For Power Supply Board

- SOLDER

Sparkle Solder 115A-1, 115B-1 OR Almit Solder KR-19, KR-19RMA

- Soldering iron

Recommended power consumption is between 30 W to 40 W.

Temperature of Copper Rod  $662 \pm 50^{\circ}\text{F}$  ( $350 \pm 10^{\circ}\text{C}$ )

(An expert may handle a 60~80 W iron, but a beginner might damage the foil by overheating.)

- Flux

HI115 Specific gravity 0.863

(Original flux should be replaced daily.)

#### 8.2.1.2. For P.C.Board with “PbF” marking

- PbF (: Pb free) Solder

- Soldering Iron

Tip Temperature of  $700^{\circ}\text{F} \pm 20^{\circ}\text{F}$  ( $370^{\circ}\text{C} \pm 10^{\circ}\text{C}$ )

**Note:** We recommend a 30 to 40 Watt soldering iron. An expert may be able to use a 60 to 80 Watt iron where someone with less experience could overheat and damage the PCB foil.

- Flux

Recommended Flux: Specific Gravity → 0.82.

Type → RMA (lower residue, non-cleaning type)

**Note:** See **ABOUT LEAD FREE SOLDER (PbF: Pb free)** (P.3).

### 8.2.2. FLAT PACKAGE IC REMOVAL PROCEDURE

1. Put plenty of solder on the IC pins so that the pins can be completely covered.

**Note:**

If the IC pins are not soldered enough, you may give pressure to the P.C. board when cutting the pins with a cutter.

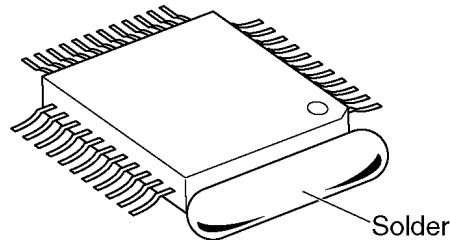

2. Make a few cuts into the joint (between the IC and its pins) first and then cut off the pins thoroughly.

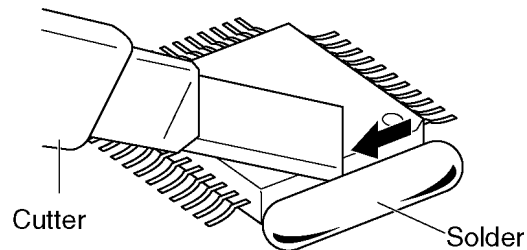

3. While the solder melts, remove it together with the IC pins.

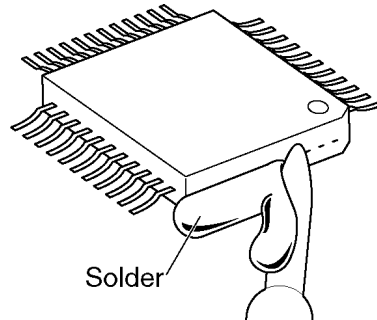

When you attach a new IC to the board, remove all solder left on the land with some tools like a soldering wire. If some solder is left at the joint on the board, the new IC will not be attached properly.



### 8.2.3. FLAT PACKAGE IC INSTALLATION PROCEDURE

1. Temporarily fix the FLAT PACKAGE IC, soldering the two marked pins.

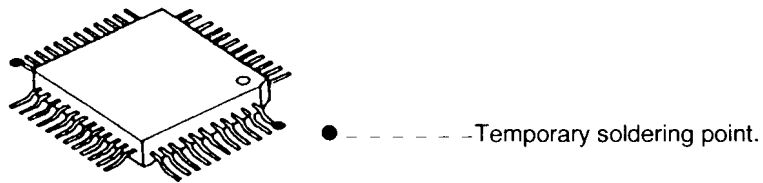

\*Check the accuracy of the IC setting with the corresponding soldering foil.

2. Apply flux to all pins of the FLAT PACKAGE IC.

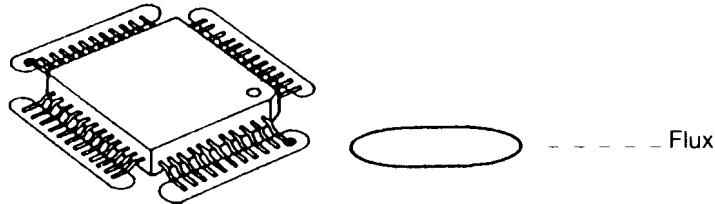

3. Solder the pins, sliding the soldering iron in the direction of the arrow.

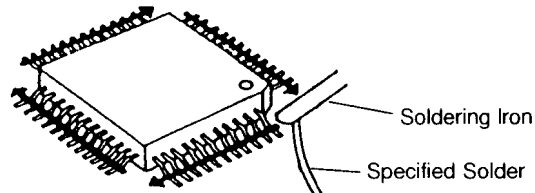

### 8.2.4. BRIDGE MODIFICATION PROCEDURE

1. Lightly resolder the bridged portion.
2. Remove the remaining solder along the pins using a soldering iron as shown in the figure below.

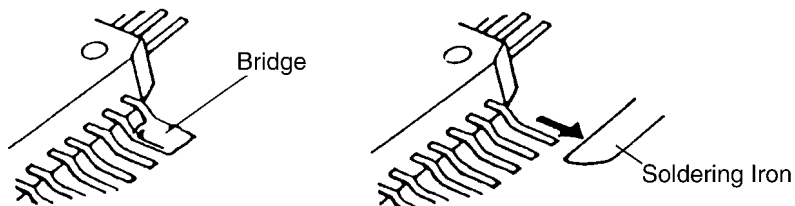

## 8.3. TEST CHART

### 8.3.1. ITU-T No.1 TEST CHART



## THE SLEREXE COMPANY LIMITED

SAPORS LANE - BOOLE - DORSET - BH 25 8 ER

TELEPHONE BOOLE (945 13) 51617 - TELEX 123456

Our Ref. 350/PJC/EAC

18th January, 1972.

Dr. P.N. Cundall,  
Mining Surveys Ltd.,  
Holroyd Road,  
Reading,  
Berks.

Dear Pete,

Permit me to introduce you to the facility of facsimile transmission.

In facsimile a photocell is caused to perform a raster scan over the subject copy. The variations of print density on the document cause the photocell to generate an analogous electrical video signal. This signal is used to modulate a carrier, which is transmitted to a remote destination over a radio or cable communications link.

At the remote terminal, demodulation reconstructs the video signal, which is used to modulate the density of print produced by a printing device. This device is scanning in a raster scan synchronised with that at the transmitting terminal. As a result, a facsimile copy of the subject document is produced.

Probably you have uses for this facility in your organisation.

Yours sincerely,

P.J. CROSS  
Group Leader - Facsimile Research



# 9 FIXTURES AND TOOLS

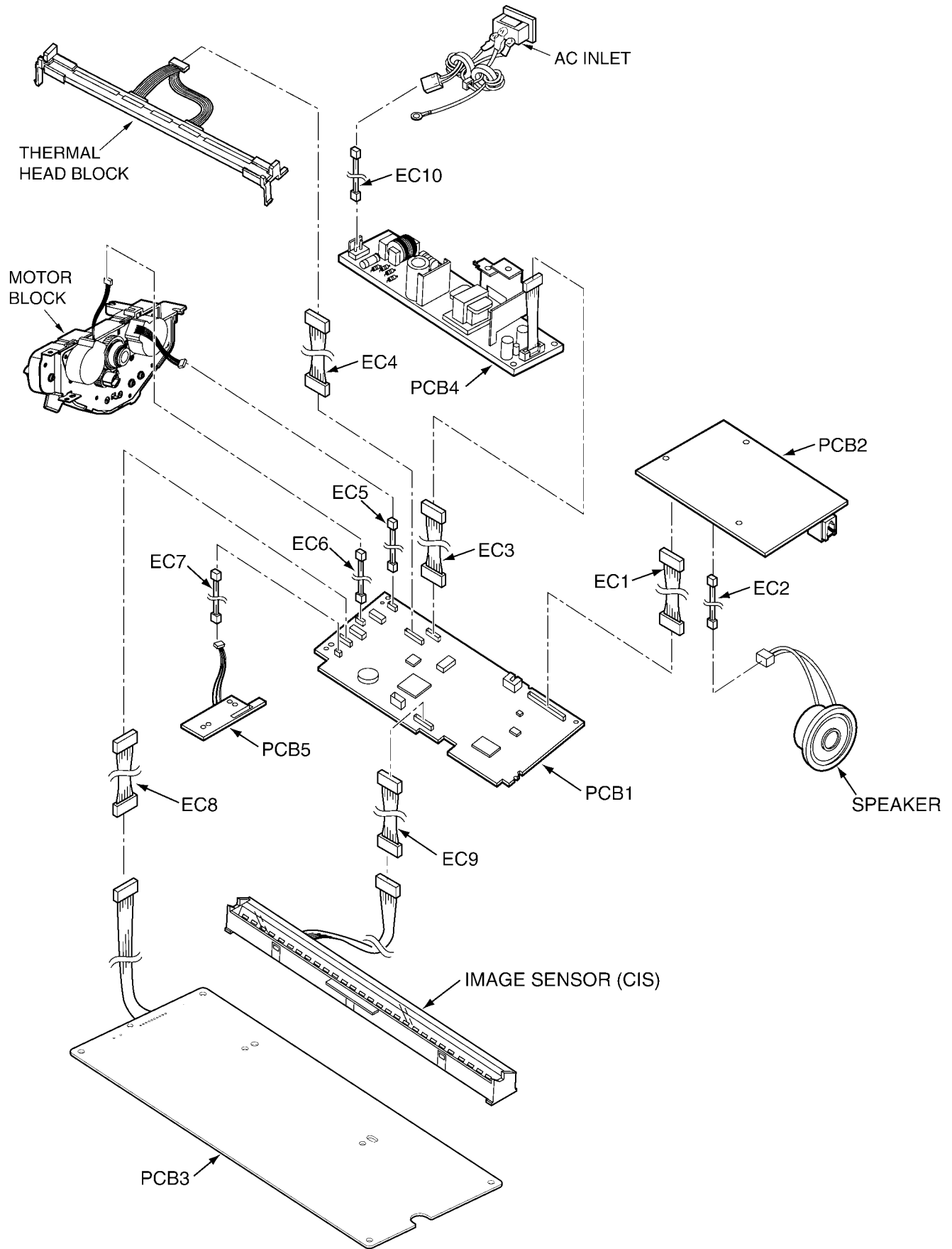

# 10 CABINET, MECHANICAL AND ELECTRICAL PARTS LOCATION

## 10.1. GENERAL SECTION

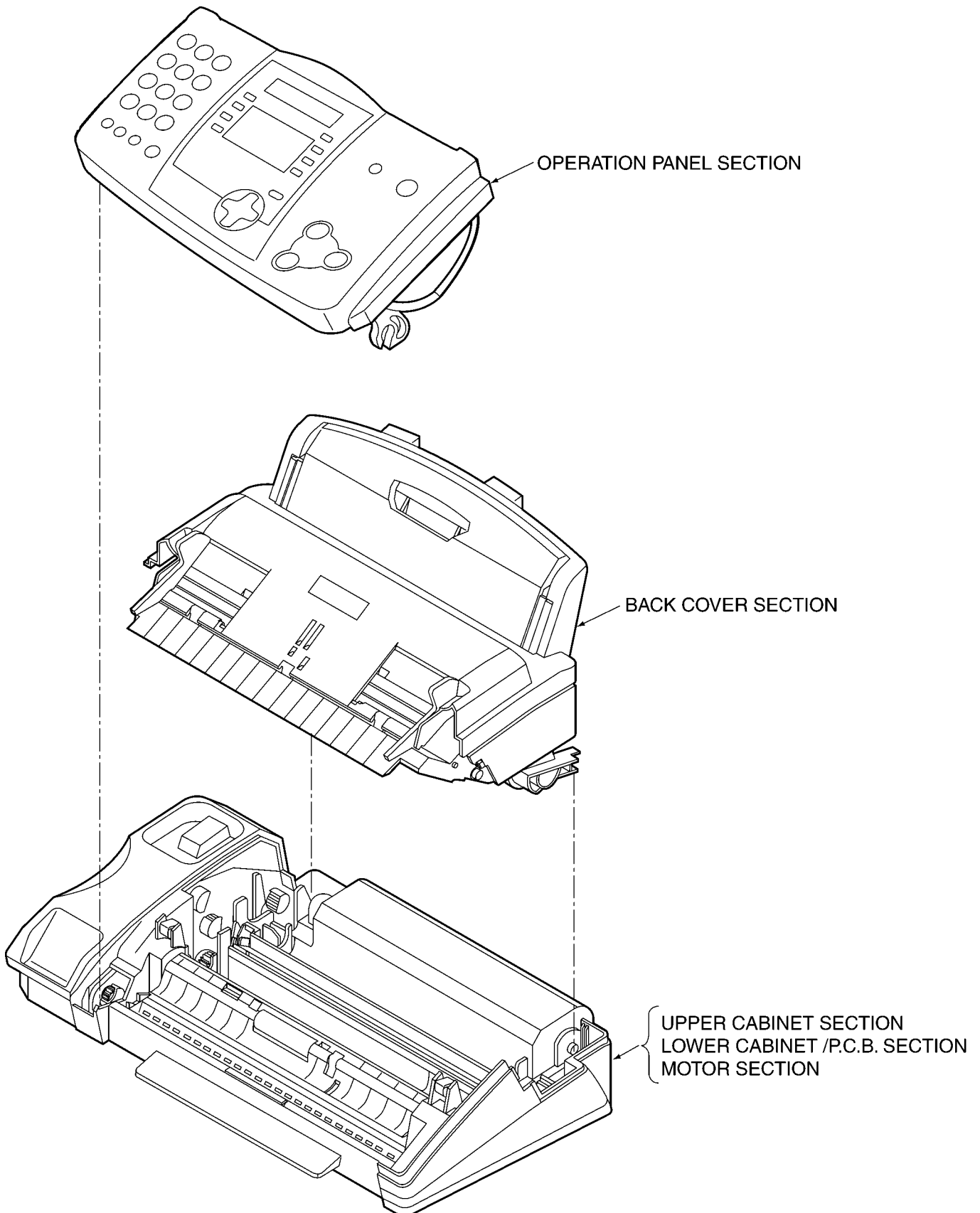

## 10.2. OPERATION PANEL SECTION

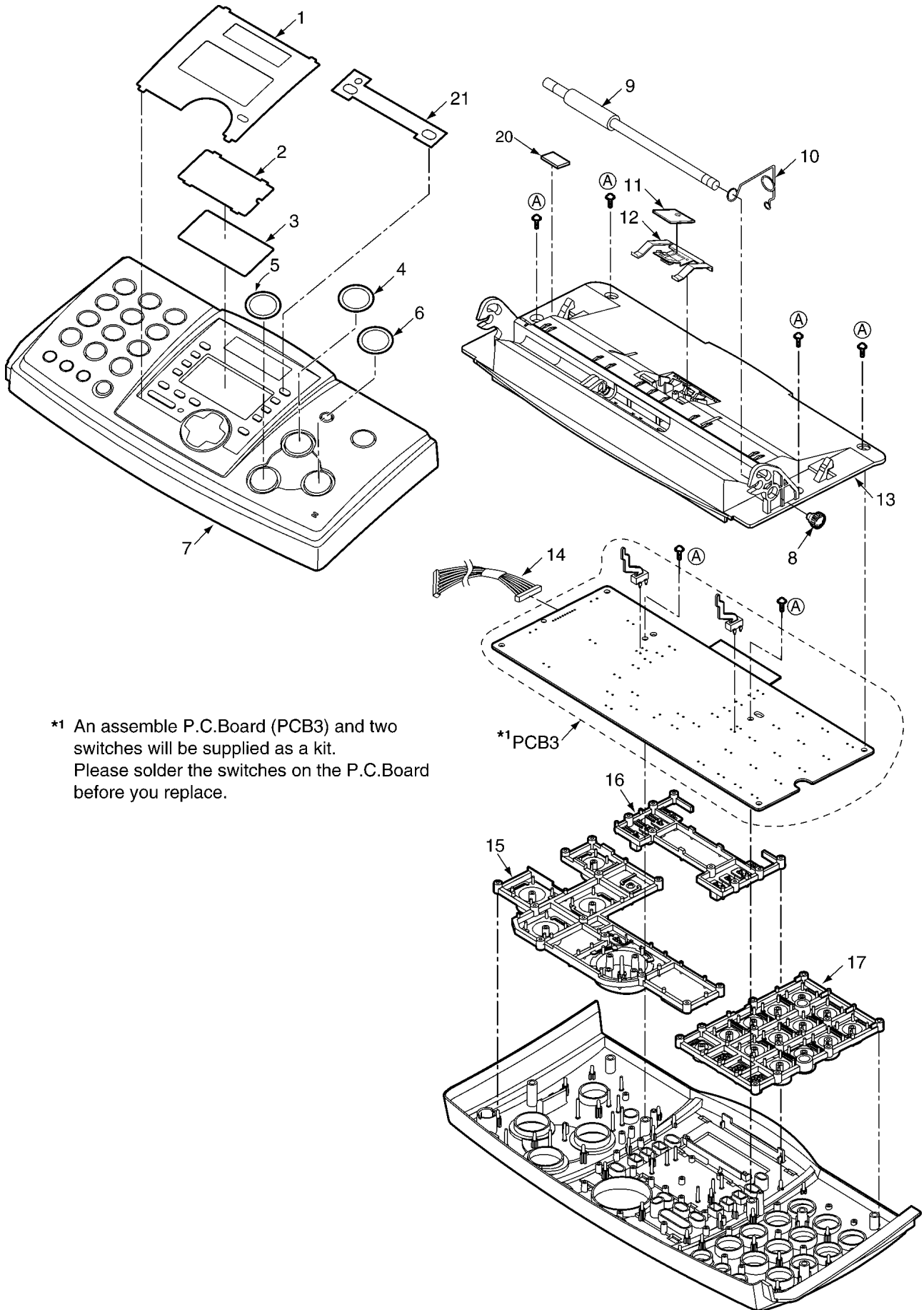

### 10.3. BACK COVER SECTION

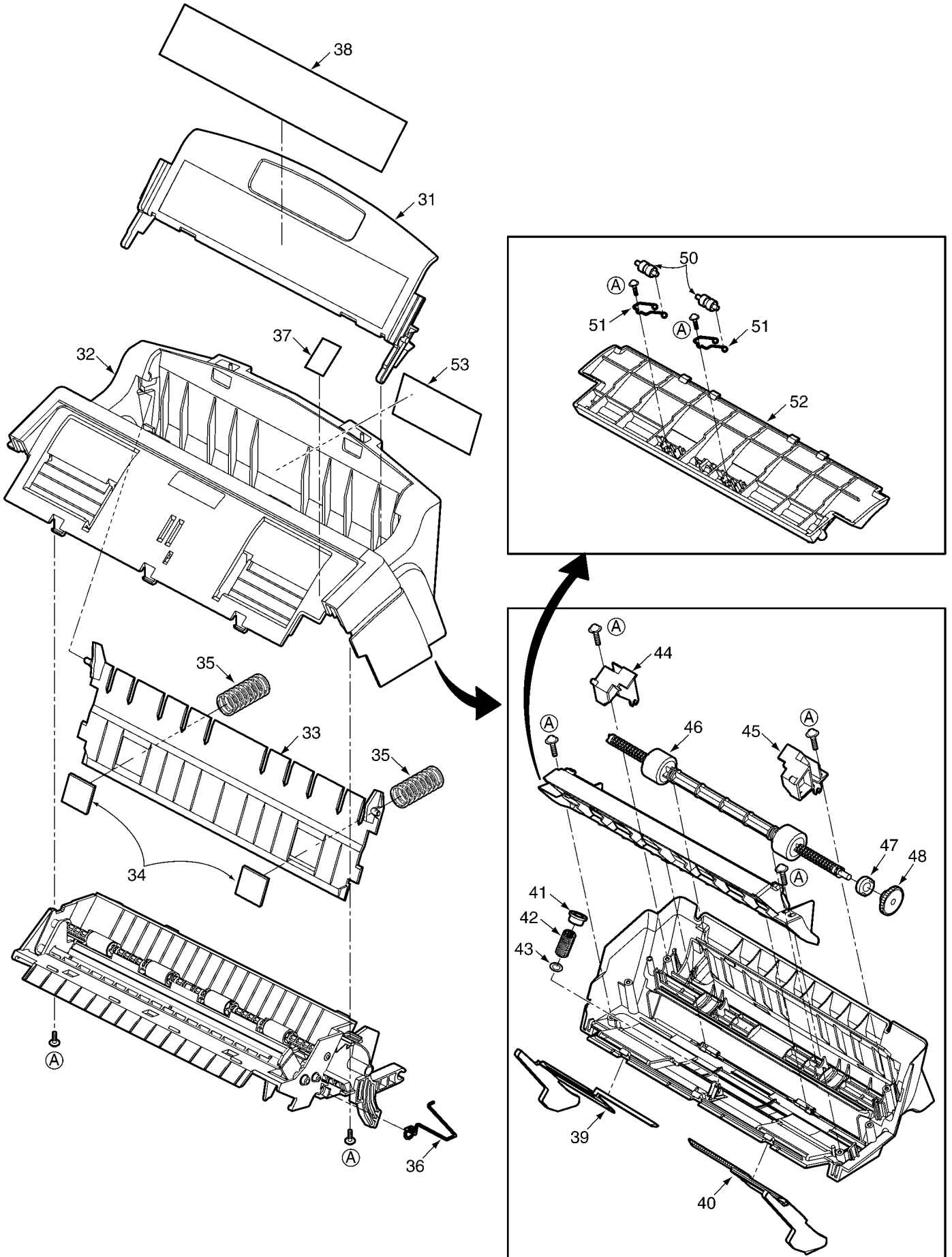

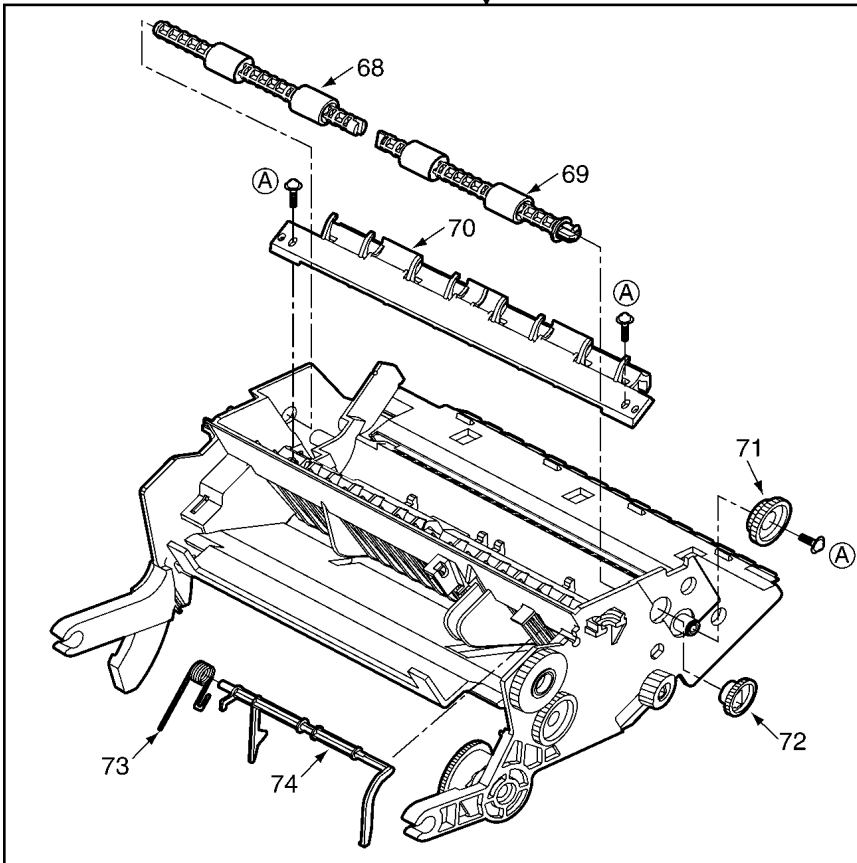
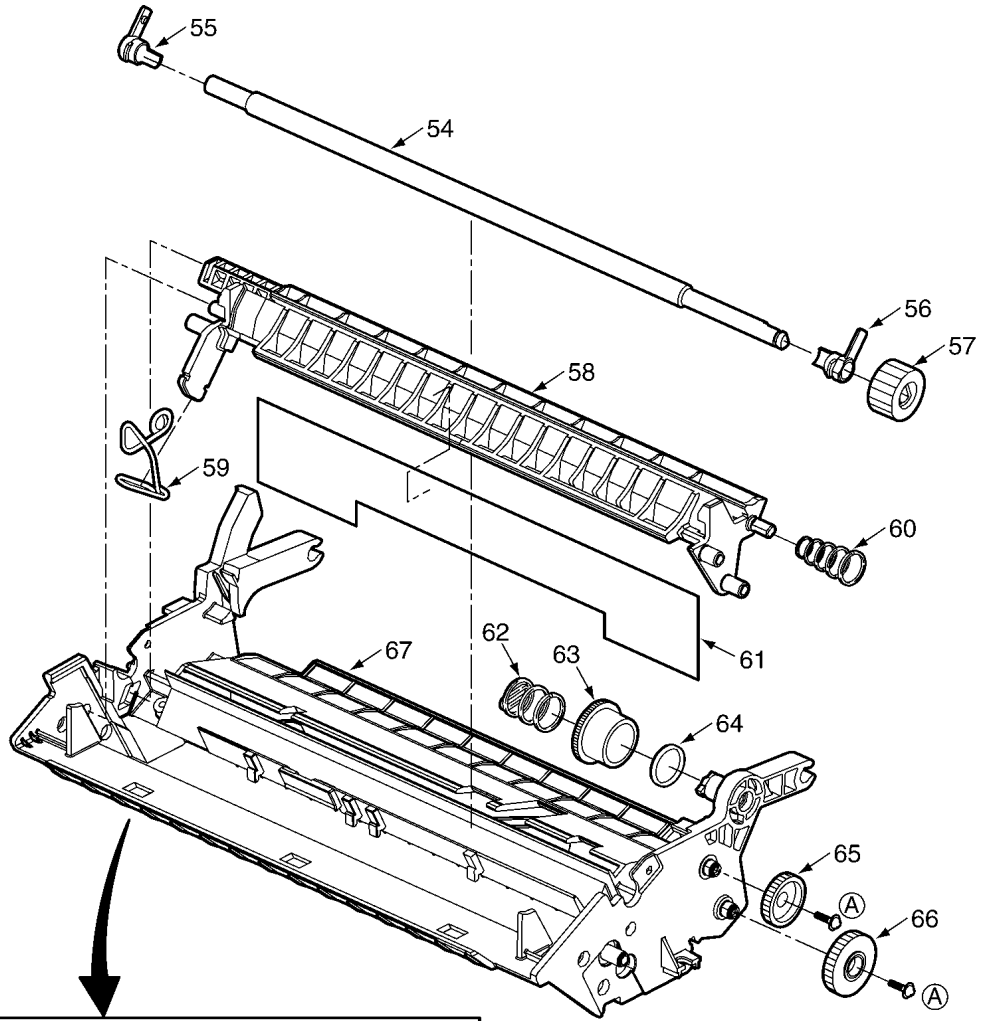



### 10.4. UPPER CABINET SECTION

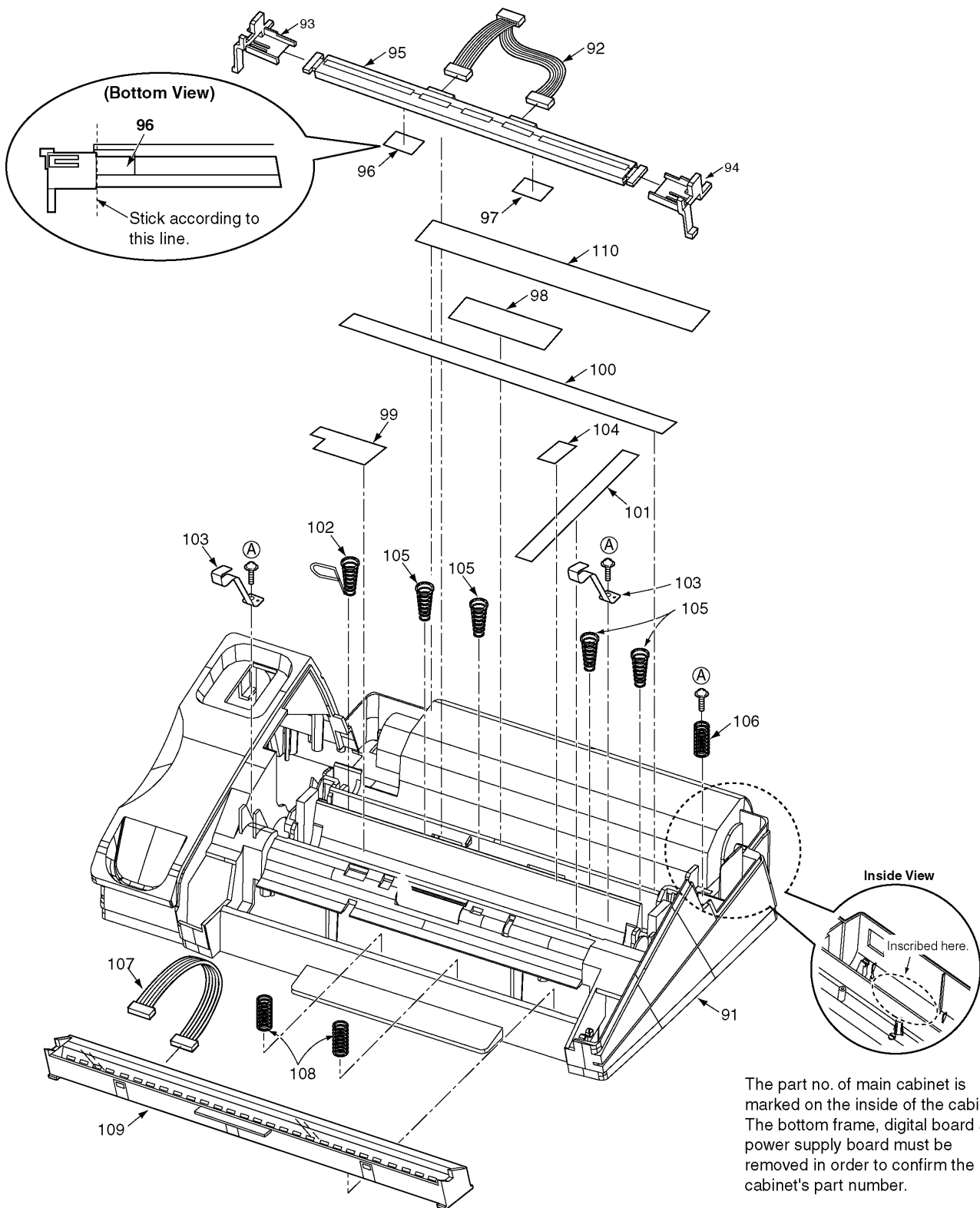

# 10.5. LOWER CABINET / P.C.BOARD SECTION

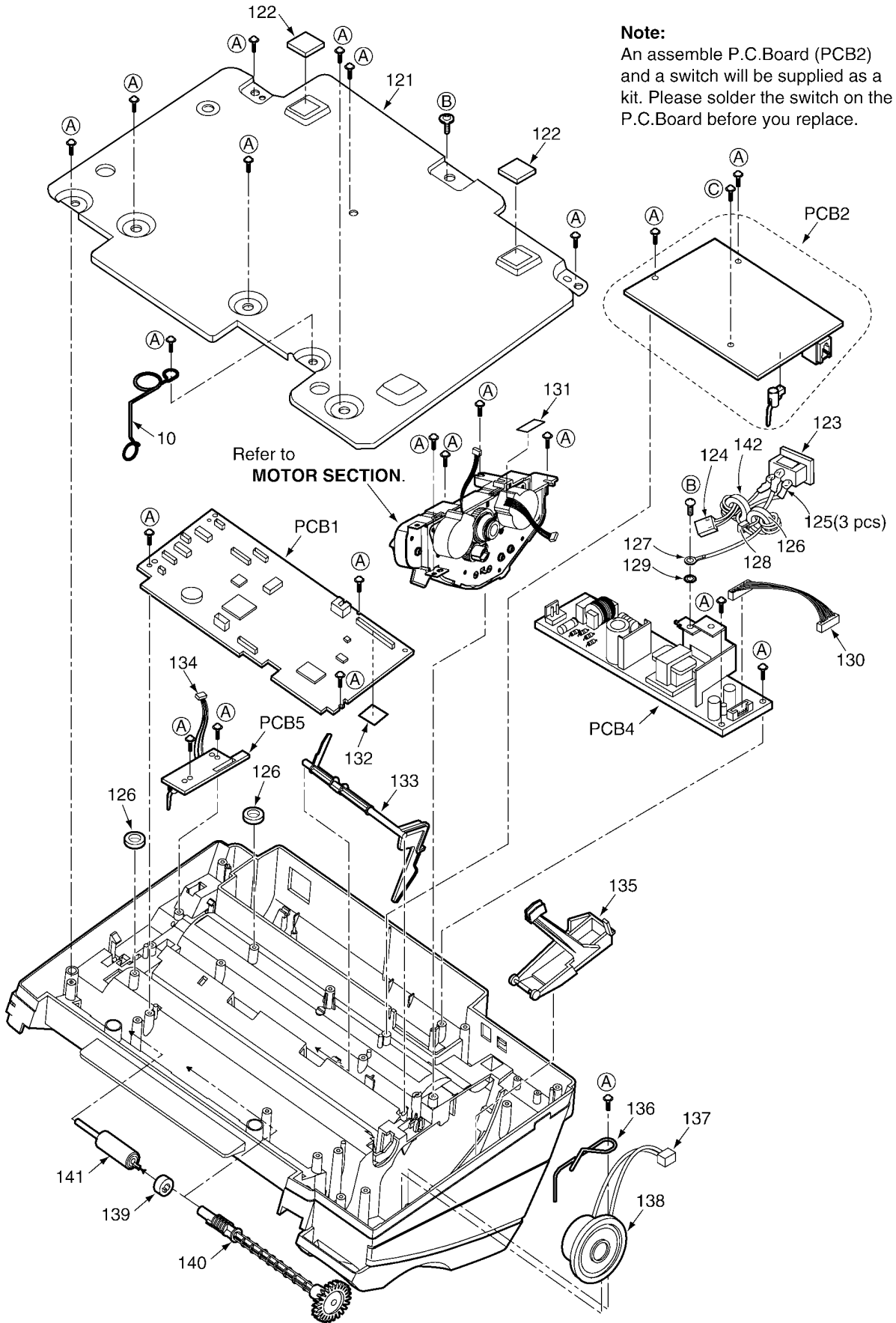

**CROSS REFERENCE:**  
**MOTOR SECTION (P.171)**

### 10.6. MOTOR SECTION

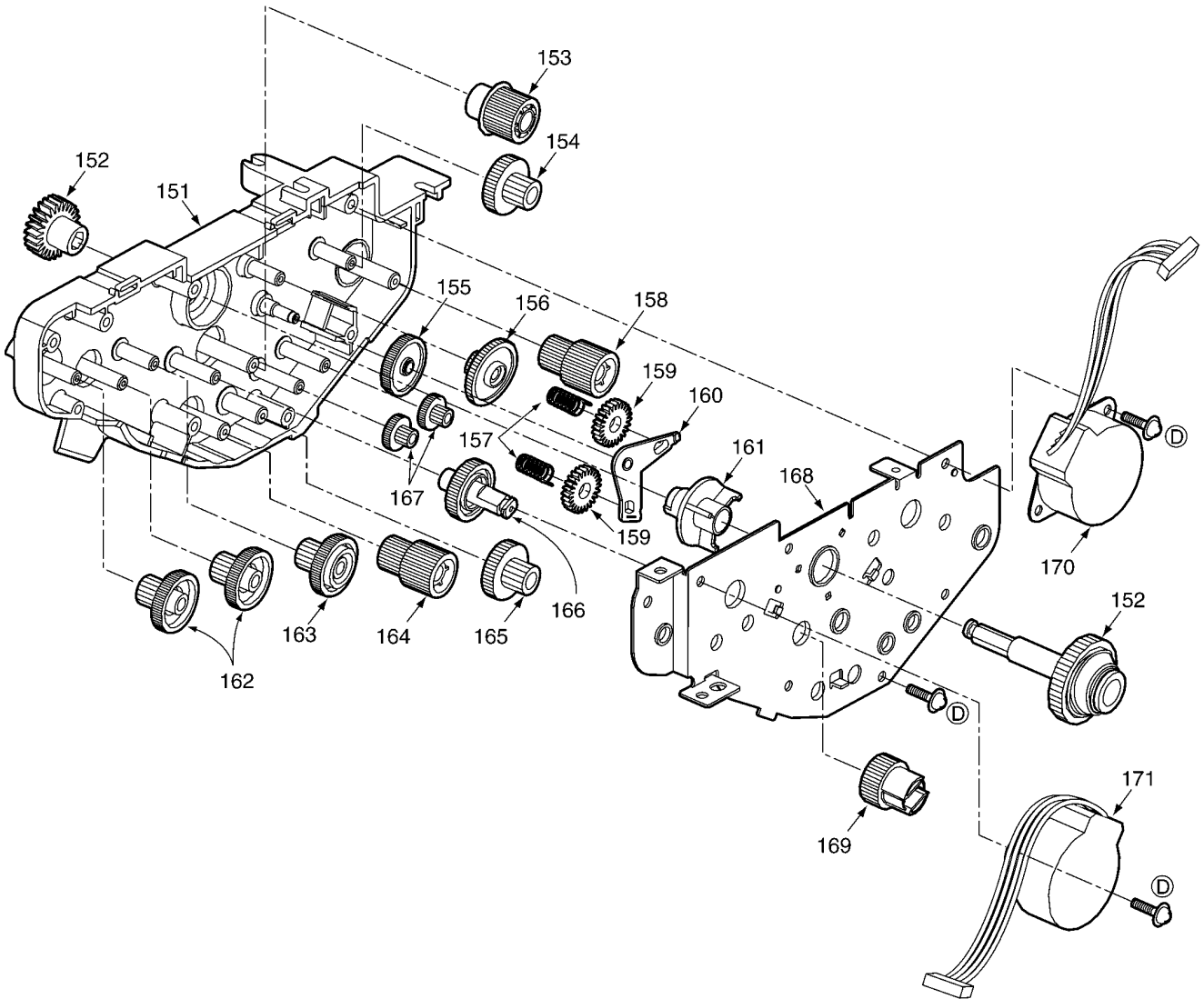

### 10.7. ACTUAL SIZE OF SCREWS

	Part No.	Illustration
(A)	XTW3+S10P	3mm
(B)	XSB4+6	
(C)	XTW3+U14L	
(D)	XTW26+10P	2.6mm
(E)	XTW3+W10P	

# 11 ACCESSORIES AND PACKING MATERIALS

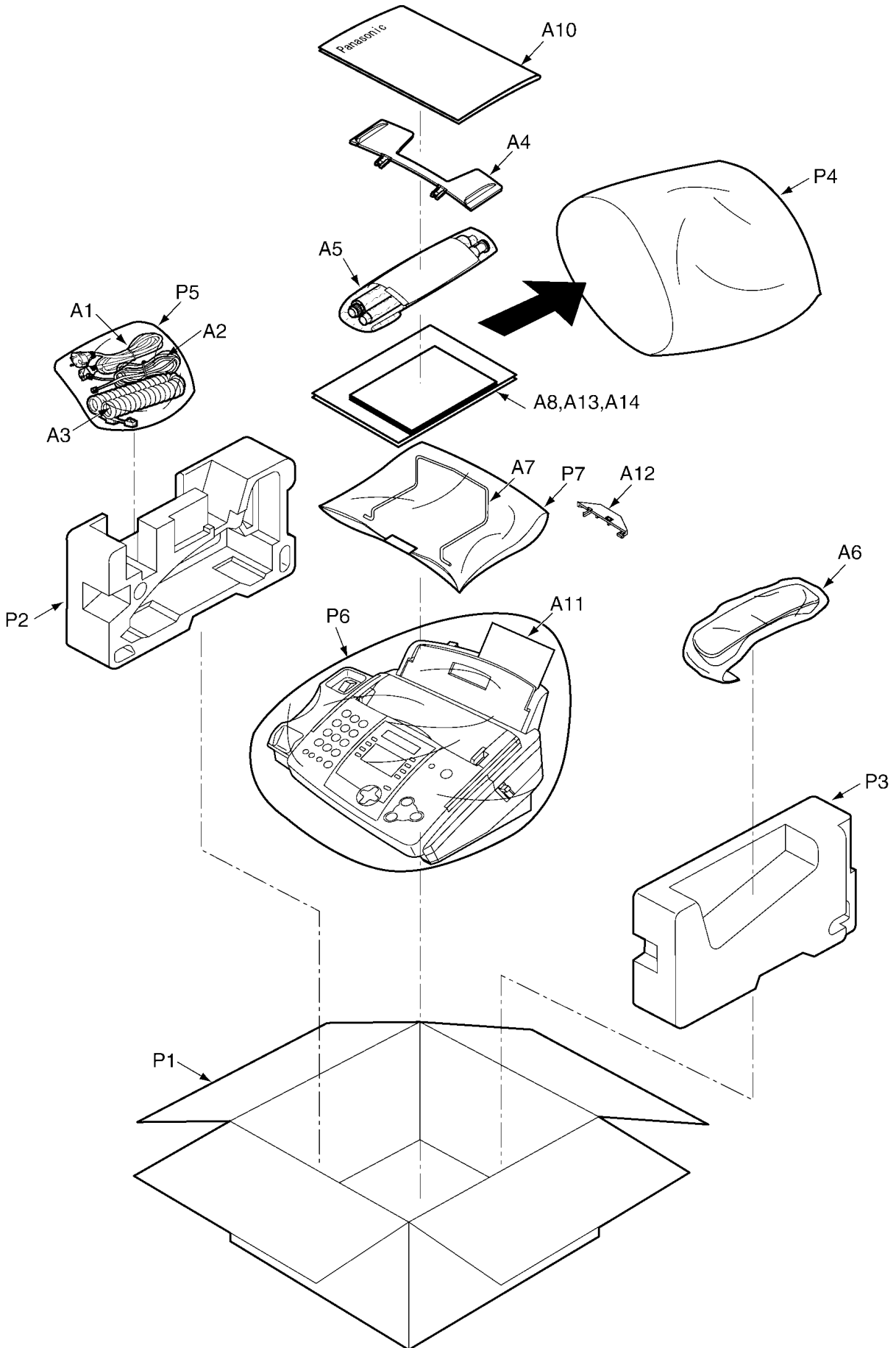

# 12 REPLACEMENT PARTS LIST

## 1. RTL (Retention Time Limited)

Note:

The marking (RTL) indicates that the Retention Time is limited for this item.

After the discontinuation of this assembly in production, the item will continue to be available for a specific period of time. The retention period of availability is dependent on the type of assembly, and in accordance with the laws governing parts and product retention.

After the end of this period, the assembly will no longer be available.

## 2. Important safety notice

Components identified by  $\triangle$  mark have special characteristics important for safety. When replacing any of these components, use only manufacture's specified parts.

3. The S mark means the part is one of some identical parts. For that reason, it may be different from the installed part.

4. ISO code (Example: ABS-HB) of the remarks column shows quality of the material and a flame resisting grade about plastics.

## 5. RESISTORS & CAPACITORS

Unless otherwise specified;

All resistors are in ohms ( $\Omega$ ) K=1000 $\Omega$ , M=1000k $\Omega$

All capacitors are in MICRO FARADS ( $\mu$ F) P= $\mu$ F

\*Type & Wattage of Resistor

Type

ERC:Solid	ERX:Metal Film	PQRD:Carbon
ERD:Carbon	ERG:Metal Oxide	PQRQ:Fuse
PQ4R:Chip	ERO:Metal Film	ERF:Wire Wound

Wattege

10,16,18:1/8W	14,25,S2:1/4W	12,50,S1:1/2W	1:1W	2:2W	5:5W
---------------	---------------	---------------	------	------	------

ECFD:Semi-Conductor	ECCD,ECKD,PQCBC,PQVP : Ceramic
ECQS:Styrol	ECQM,ECQV,ECQE,ECQU,ECQB : Polyester
PQCBX,ECUV:Chip	ECEA,ECSZ,ECOS : Electrolytic
ECMS:Mica	ECQP : Polypropylene

Voltage

ECQ Type	ECQG ECQV Type	ECSZ Type	Others		
1H : 50V	05 : 50V	OF : 3.15V	OJ : 6.3V	1V : 35V	
2A : 100V	1 : 100V	1A : 10V	1A : 10V	50,1H : 50V	
2E : 250V	2 : 200V	1V : 35V	1C : 16V	1J : 63V	
2H : 500V		OJ : 6.3V	1E,25 : 25V	2A : 100V	

## 12.1. CABINET AND ELECTRICAL PARTS

### 12.1.1. OPERATION PANEL SECTION

Ref. No.	Part No.	Part Name & Description	Remarks
1	PFGP1220V	PANEL, LCD	
2	PFGV1014Z	TRANSPARENT PLATE	
3	PFGD1049Z	CARD, TEL.	
4	PFHX1616Z	PLASTIC PARTS, RING COPY	
5	PFHX1618Z	PLASTIC PARTS, RING STOP	
6	PFHX1617Z	PLASTIC PARTS, RING START	
7	PFGG1199X1	GRILLE, OPERATION PANEL	PS-HB
8	PFDG1148Z	GEAR, DOCUMENT EXIT ROLLER	POM-HB
9	PFDN1040Z	ROLLER, DOCUMENT EXIT	

Ref. No.	Part No.	Part Name & Description	Remarks
10	PFUS1405Z	TORSION SPRING, EARTH	
11	PFHG1075Z	RUBBER PARTS, DOC. SEPARATION	
12	PFUS1417Z	LEAF SPRING, DOC. SEPARATION	
13	PFUV1054W	COVER, OPERATION PANEL	PS-HB
14	PFJS08Q86Z	CONNECTOR, 8 PIN	
15	PFBX1181Y1	PUSH BUTTON, START	ABS-HB
16	PFBX1180Z1	PUSH BUTTON, DIRECTION	ABS-HB
17	PFBX1179X1	PUSH BUTTON, DIAL	ABS-HB
18	Not Used		
19	Not Used		
20	PFHX1620Z	SPACER, SHEET	
21	PFHX1630Z	SPACER, LCD SHEET	

### 12.1.2. BACK COVER SECTION

Ref. No.	Part No.	Part Name & Description	Remarks
31	PFDE1189Y1	LEVER, CASSETTE	PS-HB
32	PFKV1071Y1	COVER, U TURN	PS-HB
33	PFKS1039W	TRAY, CASSETTE PLATE	PS-HB
34	PFHG1088Z	RUBBER PARTS, PAPER SEPARATION	
35	PFUS1414Z	TORSION SPRING, PICK UP	
36	PFUS1409Z	TORSION SPRING, EARTH	
37	PFQT1945Z	INDICATION LABEL, OPEN	
38	PFQT1932N	INDICATION LABEL, PAPER SET	
39	PFKR1028Y1	GUIDE, DOCUMENT/R	ABS-HB
40	PFKR1027X1	GUIDE, DOCUMENT/L	ABS-HB
41	PFDG1293Z	GEAR, DOCUMENT	POM-HB
42	PFUS1034Z	TORSION SPRING, GUIDE DOC.	
43	PFHX1605Z	SPACER, SLIDER GEAR SHEET	
44	PFHR1188Y	GUIDE, CORNER/R	POM-HB
45	PFHR1187Y	GUIDE, CORNER/L	POM-HB
46	PFDN1062Z	ROLLER, PICK UP	POM-HB
47	PFDE1188Z	SPACER, PICK UP DELAY	POM-HB
48	PFDG1290Z	GEAR, PICK UP ROLLER	POM-HB
49	Not Used		
50	PFDR1040Z	ROLLER, SUPPORT	
51	PFUS1407Y	TORSION SPRING, EXIT SUB ROLLER	
52	PFUV1055Y	COVER, GUIDE	PS-HB
53	PFGT2188Z-M	NAME PLATE, AL	S
54	PFDN1043Z	ROLLER, PLATEN	
55	PFDJ1029Z	SPACER, PLATEN/L	POM-HB
56	PFDJ1030Z	SPACER, PLATEN/R	POM-HB
57	PFDG1165Y	GEAR, PLATEN	POM-HB
58	PFDE1192Y1	LEVER, LOCK	ABS-GF20-HB
59	PFUS1404Z	TORSION SPRING, EARTH LEVER	
60	PFUS1258Z	COIL SPRING, LOCK LEVER	
61	PFHX1596Z	SPACER, LOCK LEVER SHEET	
62	PFUS1232Z	COIL SPRING, BACK TENSION	
63	PFDG1160Z	GEAR BACK TENSION	POM-HB
64	PFHS1029Z	COVER, BACK TENSION	
65	PFDG1291Z	GEAR, PICK UP IDLER	POM-HB
66	PFDG1292Z	GEAR, PICK UP IDLER	POM-HB
67	PFUA1042Y	CHASSIS, U TURN	PS-HB
68	PFDN1060Z	ROLLER, EXIT/L	POM-HB
69	PFDN1061Z	ROLLER, EXIT/R	POM-HB
70	PFUG1015Z	GUIDE, BASE	PS-HB
71	PFDG1289Z	GEAR, EXIT IDLER	POM-HB
72	PFDG1288Z	GEAR, EXIT ROLLER	POM-HB
73	PFUS1237Z	COIL SPRING, PAPER TOP	
74	PFDE1194Z	LEVER, PAPER TOP SENSOR	POM-HB

### 12.1.3. UPPER CABINET SECTION

Ref. No.	Part No.	Part Name & Description	Remarks
91	PFKML103V1	CABINET BODY, MAIN	PS-V0
92	PFJS11Q69Y	CONNECTOR, 11 PIN	
93	PFHR1373Z	GUIDE, HOLDER HEAD/L	POM-HB
94	PFHR1374Z	GUIDE, HOLDER HEAD/R	POM-HB
95	PFJHS026Z	PRINTER UNITS, THERMAL HEAD	S
96	PFHX1606Z	SPACER, HEAD SHEET	
97	PFHX1607Z	SPACER, HEAD SHEET	
98	PFHX1608Z	SPACER, RIBBON GUIDE SHEET	
99	PFQT2089Z	INDICATION LABEL, BLUE GEAR	
100	PFHX1462Z	COVER, STATIC ELEC. SHEET	
101	PFHX1344Z	INSULATOR, STATIC ELEC. SHEET	
102	PFUS1335Z	TORSION SPRING, HEAD	
103	PFUS1418Z	TORSION SPRING, OPERATION PANEL LOCK	
104	PFHX1491Z	SPACER, JOINT SHEET	
105	PFUS1235Z	COIL SPRING, HEAD	
106	PFUS1254Z	COIL SPRING, POP UP	
107	PFJS10Q72Z	CONNECTOR, 10 PIN	
108	PFUS1233Z	COIL SPRING, CIS	
109	N2GZBE000004	IMAGE SENSOR, CIS	
110	PFQT1934Z	INDICATION LABEL, INK FILM	

### 12.1.4. LOWER CABINET / P.C.B. SECTION

Ref. No.	Part No.	Part Name & Description	Remarks
121	PFMD1063Y	FRAME, BOTTOM	
122	PFHG1050Z	RUBBER PARTS, LEG	
123	PFJP03S04Z	CONNECTOR, 3 PIN	△
124	PFJS02R19Y	CONNECTOR, 2 PIN	
125	PQMX10010Z	COVER, SUMI TUBE	
126	PQLB1E1	INSULATOR, FERRITE CORE	S
127	WLR18YK26CM4	LEAD WIRE, EARTH	S
128	PQHR945Z	BAND	
129	XWC4B	WASHER	
130	PFJS07Q67Z	CONNECTOR	
131	PFHX1350Z	SPACER, HEAD SHEET	
132	PFHX1588Z	SPACER, DIGITAL SHEET	
133	PFDE1191Y	LEVER, PAPER TOP SENSOR	POM-HB
134	PFJS03Q47Z	CONNECTOR, 3 PIN	
135	PFBH1022Y1	PUSH BUTTON, HOOK	ABS-HB
136	PFUS1338Y	TORSION SPRING, SPEAKER	
137	PFJS02Q68Z	CONNECTOR, 2 PIN	
138	PFAS50P006Z	SPEAKER	S
139	PFDE1133Z	SPACER, DELAY	POM-HB
140	PFDF1087Z	SHAFT, DOC. SEPARATION	POM-HB
141	PFDR1014Z	ROLLER, DOC. SEPARATION	
142	KR06TT251508	INSULATOR, FERRITE CORE	S

### 12.1.5. MOTOR SECTION

Ref. No.	Part No.	Part Name & Description	Remarks
151	PFUA1041Y	CHASSIS, GEAR BASE	PBT+ABS -V1
152	PFDX1022Z	GEAR ASS'Y, TORQUE LIMIT	POM-HB
153	PFDG1151Z	GEAR	POM-HB
154	PFDG1287Z	GEAR	POM-HB
155	PFDG1150Z	GEAR	POM-HB
156	PFDG1149Z	GEAR	POM-HB
157	PFUS1231Y	COIL SPRING	
158	PFDG1158Z	GEAR	POM-HB
159	PFDG1159Z	GEAR	POM-HB
160	PFHR1355Y	ARM	POM-HB
161	PFHR1186Z	SPACER, SUPPORT BASE	POM-HB
162	PFDG1282Z	GEAR	POM-HB
163	PFDG1283Z	GEAR	POM-HB
164	PFDG1284Z	GEAR	POM-HB
165	PFDG1285Z	GEAR	POM-HB

Ref. No.	Part No.	Part Name & Description	Remarks
166	PFDG1153Z	GEAR	POM-HB
167	PFDG1286Z	GEAR	POM-HB
168	PFMD1062Z	FRAME	
169	PFDG1154Z	GEAR	POM-HB
170	35S1S15DGNH	DC MOTOR, RX	
171	35S1S15DGNF	DC MOTOR, TX	

### 12.1.6. ACCESSORIES AND PACKING MATERIALS

Ref. No.	Part No.	Part Name & Description	Remarks
A1	PQJA10038Y	POWER CORD	△
A2	PQJA10075Z	CORD, TELEPHONE	S
A3	PFJA04C002Z	CORD, HANDSET	
A4	PFKS1076Z1	TRAY, RECORDING PAPER	PS-HB
A5	PFPE1243Z	ACCESSORY PARTS, INK RIBBON (70M)	
A6	PFJXE0805Z	HANDSET ASS'Y	S
A7	PFUS1406Z	TRAY, RECORDING PAPER SUPPORT	
A8	PFQX1830Z	INSTRUCTION BOOK	
A9	Not Used		
A10	PFQW1942Z	INSTRUCTION BOOK, QUICK START SHEET	
A11	PFHP1114Z	LEAFLET, PROTECTION PAPER	
A12	PFKS1080Z1	TRAY, A4 SPACER	
A13	PFQW1943Z	LEAFLET (ARABIC)	
A14	PFQW1944Z	LEAFLET (PERSIA)	
P1	PFPE1406Z-M	GIFT BOX	S
P2	PFPN1286Z	CUSHION, LEFT	
P3	PFPN1287Z	CUSHION, RIGHT	
P4	XZB32X45A04	PROTECTION COVER	
P5	XZB20X35A04	PROTECTION COVER	
P6	PFPH1011Z	PACKING SHEET	
P7	XZB20X30A04	PROTECTION COVER	

### 12.2. DIGITAL BOARD PARTS

Ref. No.	Part No.	Part Name & Description	Remarks
PCB1	PFWP1FP342BX	DIGITAL BOARD ASS'Y (RTL)	
		(ICs)	
IC501	C1ZBZ0001896	IC	
IC503	PFVIMS5148EF	IC	S
IC505	PFVIR676812	IC	
IC507	PFVII5510011	IC	
IC508	PFVIT2003APS	IC	S
IC509	PQVITC4066BF	IC	S
IC510	PFVIT2003APS	IC	S
IC511	PFVINJM4558M	IC	S
IC520	C1ZBZ0002029	IC	
IC523	PFWIFP342BX	IC (ROM)	
		(TRANSISTORS)	
Q501	PQVTDTC143E	TRANSISTOR (SI)	S
Q502	2SB1322	TRANSISTOR (SI)	S
Q503	PQVTDTC143E	TRANSISTOR (SI)	S
Q504	2SB1322	TRANSISTOR (SI)	S
Q505	2SD1819A	TRANSISTOR (SI)	S
Q506	2SD1819A	TRANSISTOR (SI)	S
Q507	PQVTDTC143E	TRANSISTOR (SI)	S
Q508	2SD1819A	TRANSISTOR (SI)	S
Q509	2SD1819A	TRANSISTOR (SI)	S
Q510	PQVTDTC114EU	TRANSISTOR (SI)	S
Q511	2SD1819A	TRANSISTOR (SI)	S
Q514	2SB1218A	TRANSISTOR (SI)	
Q517	PQVTDTC143E	TRANSISTOR (SI)	S
Q518	2SD1819A	TRANSISTOR (SI)	S
Q524	PQVTDTC114EU	TRANSISTOR (SI)	S

Ref. No.	Part No.	Part Name & Description	Remarks
Q525	UN5113	TRANSISTOR(SI)	S
Q526	PQVTDTC143E	TRANSISTOR(SI)	S
IC506	PFVTSI4431DY	TRANSISTOR(SI)	S
		(DIODES)	
D501	PFVDRMRLS245	DIODE(SI)	S
D502	MA7160	DIODE(SI)	
D503	RLS71	DIODE(SI)	
D504	PFVDRMRLS245	DIODE(SI)	S
D505	MA7160	DIODE(SI)	
		(BATTERY)	
BAT501	PFSU1004Z	LITHIUM BATTERY	S
		(CONNECTORS)	
CN503	PQJP10G30Z	CONNECTOR, 10 PIN	S
CN504	PQJP8G30Z	CONNECTOR, 8 PIN	S
CN505	PQJP11G30Z	CONNECTOR, 11 PIN	S
CN506	PQJP7G30Y	CONNECTOR, 7 PIN	S
CN508	PQJS08X54Z	CONNECTOR, 8 PIN	
CN512	PQJP3G30Y	CONNECTOR, 3 PIN	S
CN515	PQJP5G30Y	CONNECTOR, 5 PIN	S
CN516	PQJP05G100Z	CONNECTOR, 5 PIN	
CN517	PQJP16A19Z	CONNECTOR, 16 PIN	S
		(FUSE RESISTORS)	
F503	PFRB0031125T	FUSE RESISTOR	S
F504	PFRB0031125T	FUSE RESISTOR	S
		(CERAMIC FILTERS)	
L506	PFVF1A121ST	CERAMIC FILTER	
L514	PFVF1A121ST	CERAMIC FILTER	
		(COILS)	
L512	PQLQR2KA20T	COIL	S
L519	PQLQR2KA113	COIL	S
L522	PQLQR2KA20T	COIL	S
L531	PQLQR2KA20T	COIL	S
L532	PQLQR2KA113	COIL	S
L533	PQLQR2KA113	COIL	S
		(COMPONENTS COMBINATIONS)	
RA506	EXB38V271JV	RESISTOR ARRAY	
RA509	EXB38V101JV	RESISTOR ARRAY	
RA510	EXB38V101JV	RESISTOR ARRAY	
RA511	EXB38V271JV	RESISTOR ARRAY	
RA513	EXB38V103JV	RESISTOR ARRAY	
RA514	EXB38V101JV	RESISTOR ARRAY	
RA515	EXB38V101JV	RESISTOR ARRAY	
RA516	EXB38V101JV	RESISTOR ARRAY	
RA517	EXB38V101JV	RESISTOR ARRAY	
		(CRYSTAL OSCILLATORS)	
X501	PFVCCFS32Z	CRYSTAL OSCILLATOR	S
X502	PFVBKB240ZAT	CRYSTAL OSCILLATOR	S
X503	PFVC32256ZAT	CRYSTAL OSCILLATOR	S
		(PHOTO ELECTRIC TRANSDUCER)	
PS501	PFVISG257	PHOTO SENSOR	S
		(RESISTORS)	
L501	ERJ3GEYJ101	100	
L502	ERJ3GEYJ101	100	
L503	ERJ3GEYJ101	100	
L504	ERJ3GEYJ101	100	
L505	ERJ3GEYJ101	100	
L507	ERJ3GEY0R00	0	
L509	ERJ3GEY0R00	0	
L510	ERJ3GEY0R00	0	
L515	ERJ3GEY0R00	0	
L516	ERJ3GEYJ101	100	
L517	ERJ3GEYJ101	100	
L518	ERJ3GEY0R00	0	

Ref. No.	Part No.	Part Name & Description	Remarks
L520	ERJ3GEY0R00	0	
L525	ERJ3GEYJ101	100	
L526	ERJ3GEYJ101	100	
L527	ERJ3GEYJ101	100	
L528	ERJ3GEYJ101	100	
L529	ERJ3GEYJ101	100	
L530	ERJ3GEY0R00	0	
R501	ERJ3GEYJ562	5.6k	
R502	ERJ3GEYJ472	4.7k	
R503	ERJ3GEYJ101	100	
R504	ERJ3GEYJ181	180	
R505	ERJ3GEYJ101	100	
R506	ERJ3GEYJ181	180	
R507	ERJ3GEYJ101	100	
R510	ERJ3GEYJ101	100	
R511	ERJ3GEYJ101	100	
R512	ERJ3GEYJ101	100	
R513	ERJ3GEYJ102	1k	
R515	ERJ3GEYJ101	100	
R517	ERJ3GEYJ101	100	
R518	ERJ3GEY0R00	0	
R519	ERJ3GEYJ821	820	
R520	ERD51VJ152	1.5k	S
R522	ERJ3GEYJ223	22k	
R523	ERJ3GEYJ433	43k	
R526	ERJ3EKF1101	1.1k	
R529	ERJ3EKF3602	36k	
R531	ERJ3GEYJ334	330k	
R532	ERJ3GEYJ475	4.7M	
R533	ERJ3GEYJ203	20k	
R534	ERJ3GEY0R00	0	
R535	ERJ3GEYJ821	820	
R536	ERD51VJ152	1.5k	S
R538	ERJ3GEYJ101	100	
R539	ERJ3GEYJ101	100	
R540	ERJ3GEYJ101	100	
R541	ERJ3GEYJ101	100	
R542	ERJ3GEYJ101	100	
R543	ERJ3GEYJ101	100	
R544	ERJ3GEYJ222	2.2k	
R545	ERJ3GEYJ471	470	
R548	ERJ3GEYJ103	10k	
R549	ERJ3GEYJ101	100	
R550	ERJ3GEYJ103	10k	
R551	ERJ3GEYJ101	100	
R552	ERJ3GEYJ470	47	
R553	ERJ3GEYJ105	1M	
R554	ERJ3GEYJ472	4.7k	
R555	PQ4R18XJ220	22	S
R556	ERJ6GEYJ6R8	6.8	
R557	ERJ3GEYJ271	270	
R558	ERJ3GEYJ272	2.7k	
R559	ERJ3GEYJ103	10k	
R560	ERJ3GEYJ103	10k	
R561	ERJ3GEYJ472	4.7k	
R563	ERJ3GEYJ221	220	
R564	ERJ3GEYJ103	10k	
R565	ERJ3GEYJ222	2.2k	
R566	ERJ3GEYJ102	1k	
R567	ERJ3GEYJ102	1k	
R568	ERJ3GEYJ103	10k	
R569	ERJ3GEYJ683	68k	
R570	ERJ3GEYJ474	470k	
R571	ERJ3GEYJ105	1M	
R572	ERJ3GEYJ185	1.8M	
R573	ERJ3GEYJ222	2.2k	
R574	ERJ3GEYJ152	1.5k	
R575	ERJ3GEYJ103	10k	
R576	ERJ3GEYJ103	10k	
R577	ERJ3GEY0R00	0	
R579	ERJ3GEYJ303	30k	
R580	ERJ3GEYJ154	150k	

Ref. No.	Part No.	Part Name & Description	Remarks
R581	ERJ3GEYJ103	10k	
R582	ERJ3GEYJ102	1k	
R583	ERJ3GEYJ333	33k	
R584	ERJ3GEYJ392	3.9k	
R585	ERJ3GEYJ474	470k	
R586	ERJ3GEYJ153	15k	
R587	ERJ3GEYJ473	47k	
R589	ERJ3GEYJ224	220k	
R590	ERJ3GEYJ224	220k	
R591	ERJ3GEYJ103	10k	
R593	ERJ3GEYJ563	56k	
R594	ERJ3GEYJ682	6.8k	
R597	ERJ3GEYJ334	330k	
R600	ERJ3GEYJ473	47k	
R603	ERG2SJ391	390	
R614	ERJ3GEYJ472	4.7k	
R615	ERJ3GEYJ222	2.2k	
R619	ERJ3GEYJ104	100k	
R620	ERJ8GEYJ2R2	2.2	
R621	ERJ3GEYJ4R7	4.7	
R622	PQ4R10XJ331	330	S
R625	ERJ3GEYJ101	100	
R626	ERJ3GEYJ101	100	
R629	ERJ3GEYJ101	100	
R634	ERJ3GEY0R00	0	
R653	ERJ3GEYJ101	100	
R654	ERJ3GEYJ101	100	
R655	ERJ3GEYJ101	100	
R656	ERJ3GEYJ101	100	
R659	ERJ3GEYJ472	4.7k	
R662	ERJ3GEYJ472	4.7k	
R663	ERJ3GEYJ472	4.7k	
R677	ERJ3GEYJ331	330	
R678	ERJ3GEYJ563	56k	
R679	ERJ3GEYJ562	5.6k	
R680	ERJ3GEYJ472	4.7k	
R681	ERJ3GEYJ101	100	
R682	ERJ3GEYJ103	10k	
R683	ERJ3GEYJ472	4.7k	
R684	ERJ3GEYJ472	4.7k	
R685	ERJ3GEYJ101	100	
R688	ERJ3GEY0R00	0	
R699	ERJ3GEY0R00	0	
R700	ERJ3GEY0R00	0	
R701	ERJ3GEY0R00	0	
R702	ERJ3GEYJ102	1k	
R703	ERJ3GEYJ102	1k	
R704	ERJ3GEYJ102	1k	
R705	ERJ3GEYJ103	10k	
R719	ERJ3GEYJ472	4.7k	
R720	ERJ3GEYJ103	10k	
R721	ERJ3GEYJ103	10k	
R722	ERJ3GEYJ103	10k	
R723	ERJ3GEYJ103	10k	
R724	ERJ3GEYJ103	10k	
R725	ERJ3GEYJ103	10k	
R726	ERJ3GEYJ103	10k	
R727	ERJ3GEYJ103	10k	
R728	ERJ3GEYJ472	4.7k	
R731	ERJ3GEYJ103	10k	
R742	ERJ3GEYJ271	270	
R743	ERJ3GEYJ472	4.7k	
		(CAPACITORS)	
C502	ECUV1H104ZFV	0.1	S
C503	ECEA1CK101	100	S
C504	PQCUV1H104ZF	0.1	S
C509	ECUV1H102KBV	0.001	S
C510	ECUV1H104ZFV	0.1	S
C513	ECUV1H104ZFV	0.1	S
C514	ECUV1H104ZFV	0.1	S
C515	ECUV1H104ZFV	0.1	S
C516	ECUV1H104ZFV	0.1	S

Ref. No.	Part No.	Part Name & Description	Remarks
C517	ECUV1H104ZFV	0.1	S
C518	ECUV1H222KBV	0.0022	S
C519	ECUV1C104KBV	0.1	S
C522	ECUV1C104KBV	0.1	S
C523	ECUV1H150JCV	15P	S
C524	ECUV1H104ZFV	0.1	S
C525	ECUV1H150JCV	15P	S
C526	ECUV1H102KBV	0.001	S
C527	ECUV1H104ZFV	0.1	S
C529	ECUV1H104ZFV	0.1	S
C531	ECUV1H104ZFV	0.1	S
C533	ECUV1H104ZFV	0.1	S
C534	ECEA1CK101	100	S
C535	ECUV1H104ZFV	0.1	S
C536	ECUV1H104ZFV	0.1	S
C537	ECUV1H104ZFV	0.1	S
C538	ECUV1H104ZFV	0.1	S
C539	ECUV1H101JCV	100P	S
C540	ECUV1H100JCV	10P	S
C541	ECUV1H100JCV	10P	S
C542	ECUV1H104ZFV	0.1	S
C543	ECUV1H104ZFV	0.1	S
C545	ECUV1H104ZFV	0.1	S
C546	ECUV1H104ZFV	0.1	S
C547	ECUV1H104ZFV	0.1	S
C548	ECEA1CK101	100	S
C549	ECUV1C104KBV	0.1	S
C550	ECUV1H330JCV	33P	S
C551	ECEA1CK101	100	S
C553	ECUV1H472KBV	0.0047	S
C554	ECUV1H472KBV	0.0047	S
C559	ECUV1H104ZFV	0.1	S
C560	ECUV1H104ZFV	0.1	S
C564	ECEA1CKS100	10	S
C565	ECEA1CKS100	10	S
C566	ECUV1H104ZFV	0.1	S
C568	ECUV1H102KBV	0.001	S
C569	ECUV1H104ZFV	0.1	S
C570	ECUV1C273KBV	0.027	S
C571	ECUV1C104KBV	0.1	S
C572	ECUV1H103KBV	0.01	S
C573	ECUV1C104KBV	0.1	S
C575	ECUV1H104ZFV	0.1	S
C576	ECUV1C104KBV	0.1	S
C577	ECUV1H102KBV	0.001	S
C578	ECUV1H104ZFV	0.1	S
C579	ECUV1C104KBV	0.1	S
C580	ECUV1H390JCV	39P	S
C581	ECUV1H223KBV	0.022	S
C582	PQCUV1H104ZF	0.1	S
C583	ECUV1H104ZFV	0.1	S
C584	ECUV1H181JCV	180P	S
C585	ECUV1H104ZFV	0.1	S
C586	ECUV1C104KBV	0.1	S
C588	ECEA1HKS100	10	S
C589	ECUV1H104ZFV	0.1	S
C591	ECUV1H472KBV	0.0047	S
C592	ECUV1H472KBV	0.0047	S
C598	ECUV1H120JCV	12P	S
C599	ECUV1H100JCV	10P	S
C600	ECUV1H560JCV	56P	S
C601	ECUV1C104KBV	0.1	S
C604	ECUV1H102KBV	0.001	S
C605	ECUV1H104ZFV	0.1	S
C606	ECUV1H102KBV	0.001	S
C609	ECUV1H104ZFV	0.1	S
C610	ECUV1H104ZFV	0.1	S
C611	ECUV1H104ZFV	0.1	S
C614	ECUV1H104ZFV	0.1	S
C618	ECUV1H102KBV	0.001	S
C619	ECUV1H104ZFV	0.1	S
C620	ECUV1H104ZFV	0.1	S
C621	ECUV1H104ZFV	0.1	S



Ref. No.	Part No.	Part Name & Description	Remarks
C623	ECEA1CK101	100	S
C625	ECEA1CK101	100	S
C626	ECUV1H104ZFB	0.1	S
C628	ECUV1H104ZFB	0.1	S
C634	ECUV1H104ZFB	0.1	S
C635	ECUV1H104ZFB	0.1	S
C646	ECUV1C104KBV	0.1	S
C651	ECUV1H102KBV	0.001	S
C652	ECUV1H102KBV	0.001	S
C654	ECUV1H104ZFB	0.1	S
C655	ECUV1H104ZFB	0.1	S
C656	ECUV1H104ZFB	0.1	S
C670	ECUV1H102KBV	0.001	S

## 12.3. ANALOG BOARD PARTS

Ref. No.	Part No.	Part Name & Description	Remarks
PCB2	PFWP2HD333LS	ANALOG BOARD ASS'Y (RTL)	△
		(ICs)	
IC101	PQVINJM2904F	IC	S
IC102	PQVIMC34119M	IC	S
		(TRANSISTORS)	
Q101	2SD1819A	TRANSISTOR(SI)	S
Q102	PQVTDTC143E	TRANSISTOR(SI)	S
Q103	2SD1819A	TRANSISTOR(SI)	S
		(DIODES)	
D101	MA4056	DIODE(SI)	
D102	MA4056	DIODE(SI)	
D103	1SS119	DIODE(SI)	S
D105	1SS119	DIODE(SI)	S
D106	1SS119	DIODE(SI)	S
		(CONNECTORS AND JACKS)	
CN101	PQJS16A10Z	CONNECTOR, 16 PIN	S
CN102	PFJJ1T01Z	JACK	S
CN103	PFJJ1T01Z	JACK	S
CN104	PQJJ1TB18Z	JACK	S
CN105	PQJP02G100Z	CONNECTOR, 2 PIN	
		(SWITCH)	
SW101	PFSHA011Z	SWITCH, HOOK	
		(COILS)	
L102	PQLQR2KA213	COIL	S
L103	PQLQR2KA213	COIL	S
L104	PQLQR2KA213	COIL	S
L105	PQLQR2KA213	COIL	S
L107	PQLQR2KA113	COIL	S
L108	PQLQR2KA113	COIL	S
L109	PQLQR2KA113	COIL	S
L110	PQLQR2KA113	COIL	S
		(PHOTO ELECTRIC TRANSDUCERS)	
PC101	0N3181	PHOTO COUPLER	△
PC105	CNC7S102	PHOTO COUPLER	△
		(THERMISTOR)	
POS101	PQRPAR390N	POSISTOR	△ S
		(RELAY)	
RLY101	PFSL001Z	RELAY	△ S
		(VARISTORS)	
SA101	PQVDDSS301L	VARIATOR (SURGE ABSORBER)	S
SA102	PFRZ002Z	VARIATOR (SURGE ABSORBER)	△ S
		(TRANSFORMER)	
T101	G4A1A0000151	TRANSFORMER	△

Ref. No.	Part No.	Part Name & Description	Remarks
		(RESISTORS)	
R101	ERJ3GEYJ123	12k	
R102	ERJ3GEYJ682	6.8k	
R103	ERJ3GEYJ222	2.2k	
R105	ERG2S151	150	
R106	ERDS1TJ103	10k	S
R107	ERDS1TJ473	47k	S
R108	ERJ3GEYJ393	39k	
R109	ERDS2TJ221	220	S
R111	ERJ3GEYJ564	560k	
R112	ERJ3GEYJ124	120k	
R114	ERJ3GEYJ183	18k	
R115	ERJ3GEYJ124	120k	
R116	ERJ3GEYJ224	220k	
R117	ERJ3GEYJ224	220k	
R118	ERJ3GEYJ222	2.2k	
R119	ERJ3GEYJ334	330k	
R121	ERDS2TJ331	330	S
R123	ERJ3GEYJ333	33k	
R124	ERJ3GEYJ913	91k	
R125	ERJ3GEYJ0R00	0	
R131	ERJ3GEYJ101	100	
R132	ERJ3GEYJ473	47k	
R133	ERJ3GEYJ331	330	
R134	ERJ3GEYJ562	5.6k	
R136	ERJ3GEYJ152	1.5k	
R137	ERJ3GEYJ331	330	
R138	ERJ3GEYJ152	1.5k	
R139	ERJ3GEYJ183	18k	
R140	ERJ3GEYJ183	18k	
R141	ERJ3GEYJ394	390k	
R142	ERJ3GEYJ394	390k	
R143	ERJ3GEYJ222	2.2k	
R149	ERJ3GEYJ680	68	
R151	ERJ3GEYJ473	47k	
R164	ERJ3GEYJ101	100	
R165	ERJ3GEYJ472	4.7k	
R171	ERJ3GEYJ103	10k	
R172	ERJ3GEYJ103	10k	
R173	ERJ3GEYJ103	10k	
R175	ERJ3GEYJ114	110k	
R176	ERJ3GEYJ154	150k	
		(CAPACITORS)	
C102	ECEA1CKS470	47	S
C108	ECQE2E105KZ	1	S
C109	ECUV1H333KDV	0.033	S
C111	ECUV1H103KBV	0.01	S
C112	ECUV1H123KBV	0.012	S
C113	ECUV1C104KBV	0.1	S
C114	ECUV1C473KBV	0.047	S
C115	ECUV1H123KBV	0.012	S
C116	ECUV1H820JCV	82P	S
C118	ECUV1H104ZFB	0.1	S
C122	ECUV1H153KBV	0.015	S
C124	ECUV1H561JCV	560P	S
C125	ECEA1HKS100	10	S
C131	ECUV1H103KBV	0.01	S
C132	ECEA1CKS100	10	S
C133	ECEA1CKS470	47	S
C134	ECUV1H472KBV	0.0047	S
C136	ECEA1CKS470	47	S
C137	ECUV1H103KBV	0.01	S
C138	ECUV1H103KBV	0.01	S
C139	ECUV1C104KBV	0.1	S
C140	ECUV1C104KBV	0.1	S
C142	ECUV1H221JCV	220P	S
C159	ECUV1H103KBV	0.01	S
C171	ECEA1HKA4R7	4.7	
C172	ECUV1C393KBV	0.039	S
C173	ECUV1H102KBV	0.001	S
C175	ECUV1H681KBV	680P	S

Ref. No.	Part No.	Part Name & Description	Remarks
C176	ECUV1H681KBV	680P	S

## 12.4. OPERATION BOARD PARTS

Ref. No.	Part No.	Part Name & Description	Remarks
PCB3	FFWP3FHD331M	OPERATION BOARD ASS'Y (RTL)	
		(IC)	
IC301	MN7D032Z9J	IC	
		(DIODE)	
LED302	PQVDSL325MC	LED	S
		(LCD)	
CN302	L5DAAF00001	LIQUID CRYSTAL DISPLAY	
		(CONNECTOR)	
CN301	PQJP8G43Y	CONNECTOR, 8 PIN	S
		(SWITCHES)	
SW301	PQSH1A105Z	PUSH SWITCH	S
SW302	PQSH1A105Z	PUSH SWITCH	S
SW303	PQSH1A105Z	PUSH SWITCH	S
SW304	PQSH1A105Z	PUSH SWITCH	S
SW305	PQSH1A105Z	PUSH SWITCH	S
SW306	PQSH1A105Z	PUSH SWITCH	S
SW307	PQSH1A105Z	PUSH SWITCH	S
SW308	PQSH1A105Z	PUSH SWITCH	S
SW309	PQSH1A105Z	PUSH SWITCH	S
SW310	PQSH1A105Z	PUSH SWITCH	S
SW311	PQSH1A105Z	PUSH SWITCH	S
SW312	PQSH1A105Z	PUSH SWITCH	S
SW313	PQSH1A105Z	PUSH SWITCH	S
SW314	PQSH1A105Z	PUSH SWITCH	S
SW315	PQSH1A105Z	PUSH SWITCH	S
SW316	PQSH1A105Z	PUSH SWITCH	S
SW317	PQSH1A105Z	PUSH SWITCH	S
SW318	PQSH1A105Z	PUSH SWITCH	S
SW319	PQSH1A105Z	PUSH SWITCH	S
SW320	PQSH1A105Z	PUSH SWITCH	S
SW321	PQSH1A105Z	PUSH SWITCH	S
SW322	PQSH1A105Z	PUSH SWITCH	S
SW326	PQSH1A105Z	PUSH SWITCH	S
SW327	PQSH1A105Z	PUSH SWITCH	S
SW328	PQSH1A105Z	PUSH SWITCH	S
SW329	PQSH1A105Z	PUSH SWITCH	S
SW330	PQSH1A105Z	PUSH SWITCH	S
SW331	PQSH1A105Z	PUSH SWITCH	S
SW332	PQSH1A105Z	PUSH SWITCH	S
SW333	PQSH1A105Z	PUSH SWITCH	S
SW334	PQSH1A105Z	PUSH SWITCH	S
SW335	PQSH1A105Z	PUSH SWITCH	S
SW336	PQSH1A105Z	PUSH SWITCH	S
SW337	PQSH1A105Z	PUSH SWITCH	S
SW352	FFSH1A002Z	SWITCH, DOCUMENT TOP	
SW353	FFSH1A002Z	SWITCH, DOCUMENT SET	
		(RESISTORS)	
R302	ERJ3GEYJ271	270	
R303	ERJ3GEYJ183	18k	
R305	ERJ3GEYJ222	2.2k	
R306	ERJ3GEYJ222	2.2k	
R313	ERJ3GEYJ221	220	
R314	ERJ3GEYJ472	4.7k	
R315	ERJ3GEYJ101	100	
R316	ERJ3GEYJ472	4.7k	
R317	ERJ3GEYJ101	100	
R318	ERJ3GEYJ4R7	4.7	
R320	ERJ3GEY0R00	0	
R321	ERJ3GEY0R00	0	

Ref. No.	Part No.	Part Name & Description	Remarks
R322	ERJ3GEY0R00	0	
R323	ERJ3GEY0R00	0	
R324	ERJ3GEY0R00	0	
R325	ERJ3GEY0R00	0	
R326	ERJ3GEY0R00	0	
		(CAPACITORS)	
C302	ECUV1C104KEV	0.1	S
C303	ECEA0JKS101	100	
C304	ECUV1C104KEV	0.1	S
C306	ECUV1H101JCV	100P	S
C308	ECUV1H331JCV	330P	S
C309	ECUV1H331JCV	330P	S
C310	ECUV1C104KEV	0.1	S
C311	ECUV1C104KEV	0.1	S
C314	ECUV1C104KEV	0.1	S
C316	ECUV1H103KBV	0.01	S
C317	ECUV1H103KEV	0.01	S

## 12.5. POWER SUPPLY BOARD PARTS

Ref. No.	Part No.	Part Name & Description	Remarks
PCB4	N0AZ2GF00001	POWER SUPPLY BOARD ASS'Y (RTL)	△
		(ICs)	
IC101	PFVIFA5317P	IC	
IC201	AN1431T	IC	
IC202	AN7805F	IC	
		(TRANSISTOR)	
Q101	2SK2651	TRANSISTOR (SI)	△
		(DIODES)	
D101	PFVD1N4005	DIODE (SI)	△ S
D102	PFVD1N4005	DIODE (SI)	△ S
D103	PFVD1N4005	DIODE (SI)	△ S
D104	PFVD1N4005	DIODE (SI)	△ S
D105	PFVDEG01C	DIODE (SI)	S
D106	MA165	DIODE (SI)	
D107	MA4220	DIODE (SI)	
D108	PQVDERA1802	DIODE (SI)	S
D201	PFVDSF5LC20U	DIODE (SI)	S
D202	PFVD11DQ10	DIODE (SI)	S
		(COIL)	
L101	ELF15N005A	COIL	△
		(COMPONENT PART)	
L103	EXCELDR35	COMPONENT PART	
		(CONNECTORS)	
CN301	PQJP7G30Z	CONNECTOR, 7PIN	△
CN31	PQJP2D98Z	CONNECTOR, 2PIN	△
		(FUSE)	
F101	PQBA2C31TRLW	FUSE	△ S
		(PHOTO ELECTRIC TRANSDUCER)	
PC101	PFVIPC123	PHOTO COUPLER	△ S
		(THERMISTOR)	
TH101	PFRT57235S80	THERMISTOR	S
		(TRANSFORMER)	
T101	PFLTSTRW226V	TRANSFORMER	△ S
		(VARIABLE RESISTOR)	
VR201	EVNDJAA03B53	VARIABLE RESISTOR	

Ref. No.	Part No.	Part Name & Description	Remarks
		(VARISTOR)	
ZNR101	ERZV10DK751U	VARISTOR	△ s
		(RESISTORS)	
R101	ERDSL1J105	1M	△
R102	ERDS2TJ334	330k	
R103	ERDS2TJ334	330k	
R104	ERG2SJ304	300k	
R105	ERX2SJR22	0.22	
R106	ERG2SJ470	47	
R107	ERG2SJ304	300k	
R108	ERDS2FJ150	15	
R109	ERDS2TJ100	10	
R121	ERJ3GEYJ103	10k	
R122	ERJ3GEYJ331	330	
R124	ERJ3GEYJ181	180	
R125	ERJ3GEYJ103	10k	
R126	ERJ3GEYF562	5.6k	
R127	ERJ3GEYJ182	1.8k	
R128	PQ4R10XJ101	100	s
R136	PQ4R10XJ104	100k	s
R137	PQ4R10XJ104	100k	s
R202	ERG2SJ152	1.5k	
R203	ERDS2FJ470	47	
R221	PQ4R10XJ222	2.2k	s
R222	PQ4R10XJ222	2.2k	s
R223	PQ4R10XJ101	100	s
R224	PQ4R10XJ273	27k	s
R225	PQ4R10XJ332	3.3k	s
		(CAPACITORS)	
C101	ECQU2A224MG	0.22	△
C102	ECQU2A104MG	0.1	△
C103	PFKD2E3KH102	0.001	s
C105	PFKDE2GA222M	0.0022	△
C106	PFCEA400SX68	68	s
C108	ECKD3A102KBP	0.001	
C109	ECA1VHG470	47	
C110	PFKDD2GA222M	0.0022	s
C119	ECKD3A470KBP	47p	
C121	ECUV1H472JCV	0.0047	
C122	ECJ1VB1A224K	0.22	
C123	ECUV1H561JCV	560p	
C124	ECUV1E104KBV	0.1	s
C201	PFCEA35F471	470	s
C202	ECKN3A102KBP	0.001	
C203	PFCEA16B470	47	s
C204	PFCEA35A47M	47	s
C205	PFCEA50A1M	1	s
C206	ECKN3A102KBP	0.001	
C221	ECUV1E104KBV	0.1	
C222	ECUV1H104ZFB	0.1	

Ref. No.	Part No.	Part Name & Description	Remarks
EC2	PQZZ2K12Z	EXTENSION CORD, 2 PIN	
EC3	PQZZ7K5Z	EXTENSION CORD, 7 PIN	
EC4	PFZZ11K12Z	EXTENSION CORD, 11 PIN	
EC5	PFZZ5K13Z	EXTENSION CORD, 5 PIN	
EC6	PQZZ5K6Z	EXTENSION CORD, 5 PIN	
EC7	PQZZ3K5Z	EXTENSION CORD, 3 PIN	
EC8	PQZZ8K18Z	EXTENSION CORD, 8 PIN	
EC9	PFZZ10K1Z	EXTENSION CORD, 10 PIN	
EC10	PQZZ2K13Z	EXTENSION CORD, 2 PIN	
	KM79811245C0	BASIC FACSIMILE TECHNIQUE	

**Note:**

Tools and Extension Cords are useful for servicing.  
(They make servicing easy.)

**12.6. SENSOR BOARD PARTS**

Ref. No.	Part No.	Part Name & Description	Remarks
PCB5	PFLP1431MZ	SENSOR BOARD ASS'Y (RTL)	
		(CONNECTOR)	
CN501	PQJP3G43Z	CONNECTOR, 3 PIN	s
		(SWITCHES)	
SW501	KOMA11000030	REED SW, FILM DETECTION	
SW502	PFSHA011Z	PUSH SWITCH, COVER OPEN	

**12.7. FIXTURES AND TOOLS**

Ref. No.	Part No.	Part Name & Description	Remarks
EC1	PFZZ16K5Z	EXTENSION CORD, 16 PIN	

# 8 REFERENCE MATERIAL DATA

## 8.1. TERMINAL GUIDE OF THE ICs TRANSISTORS AND DIODES

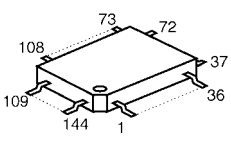
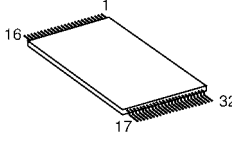
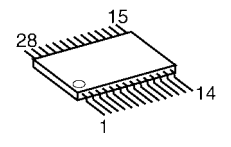
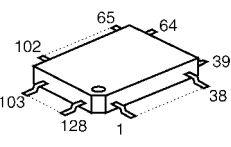
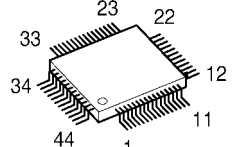
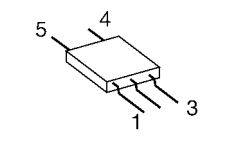
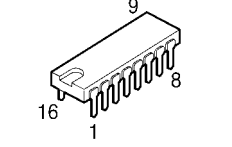
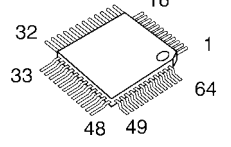
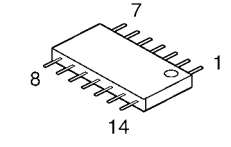
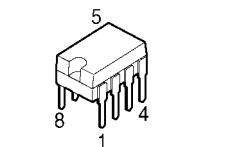
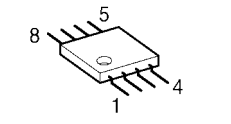
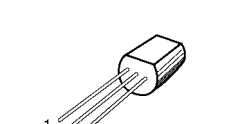
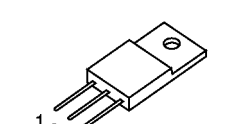
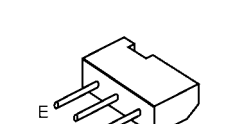
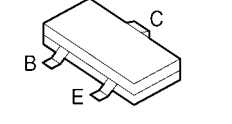
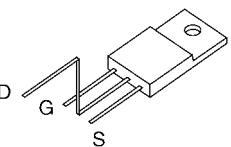
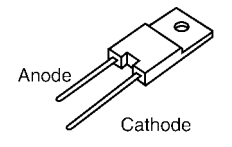
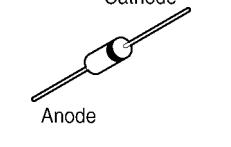
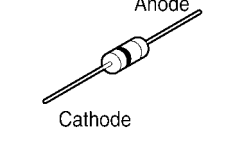
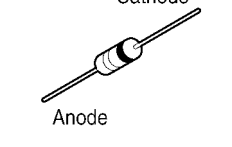
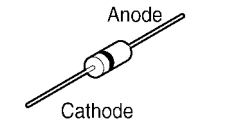
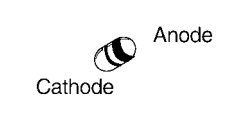
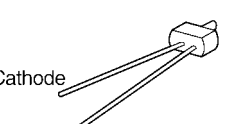
 <p>C1ZBZ0001896</p>	 <p>PFWIFP342BX</p>	 <p>PFVIMS5148EF</p>	 <p>PFVIR676812</p>	 <p>MN7D032Z9J</p>
 <p>PFVII5510011</p>	 <p>PFVIT2003APS</p>	 <p>C1ZBZ0002029</p>	 <p>PQVITC4066BF</p>	 <p>PFVIFA5317P</p>
 <p>PQVIMC34119M PFVINJM4558M PQVINJM2904F PFVTSI4431DY</p>	 <p>AN1431T</p>	 <p>AN7805F</p>	 <p>2SB1322</p>	 <p>PQVTDTC143E PQVTDTC114EU 2SB1218A, 2SD1819A UN5113</p>
 <p>PFVTF510KM10</p>	 <p>PFVDSF5LC20U</p>	 <p>1SS119</p>	 <p>MA7160, PFVD1N4005 MA4220, PFVDD1NL20U</p>	 <p>PFVDRMRLS245 MA4056</p>
 <p>PQVDERA1802 PFVDEG01C, MA165</p>	 <p>RLS71</p>	 <p>PQVDSL325MC</p>		

## 8.2. HOW TO REPLACE THE FLAT PACKAGE IC

Even if you do not have the special tools (for example, a spot heater) to remove the Flat IC, with some solder (large amount), a soldering iron and a cutter knife, you can easily remove the ICs that have more than 100 pins.

### 8.2.1. PREPARATION

#### 8.2.1.1. For Power Supply Board

- SOLDER

Sparkle Solder 115A-1, 115B-1 OR Almit Solder KR-19, KR-19RMA

- Soldering iron

Recommended power consumption is between 30 W to 40 W.

Temperature of Copper Rod  $662 \pm 50^{\circ}\text{F}$  ( $350 \pm 10^{\circ}\text{C}$ )

(An expert may handle a 60~80 W iron, but a beginner might damage the foil by overheating.)

- Flux

HI115 Specific gravity 0.863

(Original flux should be replaced daily.)

#### 8.2.1.2. For P.C.Board with "PbF" marking

- PbF (: Pb free) Solder

- Soldering Iron

Tip Temperature of  $700^{\circ}\text{F} \pm 20^{\circ}\text{F}$  ( $370^{\circ}\text{C} \pm 10^{\circ}\text{C}$ )

**Note:** We recommend a 30 to 40 Watt soldering iron. An expert may be able to use a 60 to 80 Watt iron where someone with less experience could overheat and damage the PCB foil.

- Flux

Recommended Flux: Specific Gravity  $\rightarrow 0.82$ .

Type  $\rightarrow$  RMA (lower residue, non-cleaning type)

**Note:** See **ABOUT LEAD FREE SOLDER (PbF: Pb free)** (P.3).

### 8.2.2. FLAT PACKAGE IC REMOVAL PROCEDURE

1. Put plenty of solder on the IC pins so that the pins can be completely covered.

**Note:**

If the IC pins are not soldered enough, you may give pressure to the P.C. board when cutting the pins with a cutter.

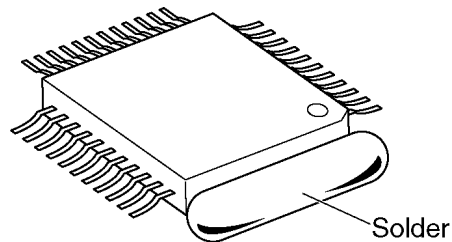

2. Make a few cuts into the joint (between the IC and its pins) first and then cut off the pins thoroughly.

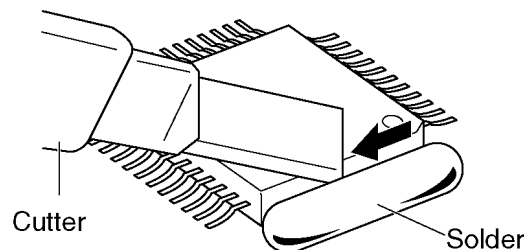

3. While the solder melts, remove it together with the IC pins.

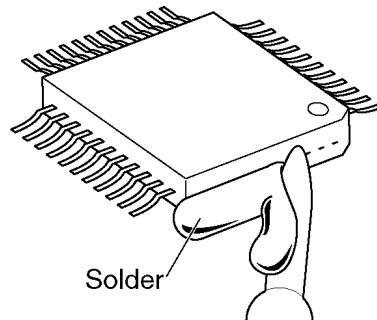

When you attach a new IC to the board, remove all solder left on the land with some tools like a soldering wire. If some solder is left at the joint on the board, the new IC will not be attached properly.

### 8.2.3. FLAT PACKAGE IC INSTALLATION PROCEDURE

1. Temporarily fix the FLAT PACKAGE IC, soldering the two marked pins.

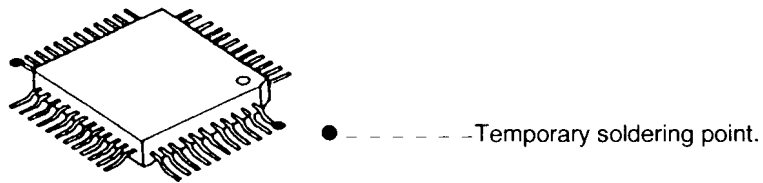

\*Check the accuracy of the IC setting with the corresponding soldering foil.

2. Apply flux to all pins of the FLAT PACKAGE IC.

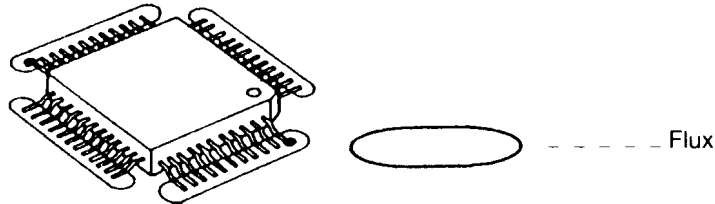

3. Solder the pins, sliding the soldering iron in the direction of the arrow.

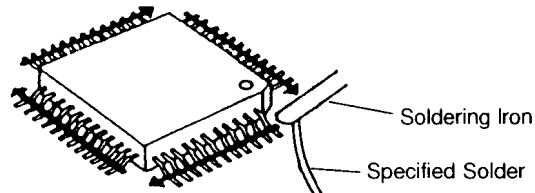

### 8.2.4. BRIDGE MODIFICATION PROCEDURE

1. Lightly resolder the bridged portion.
2. Remove the remaining solder along the pins using a soldering iron as shown in the figure below.

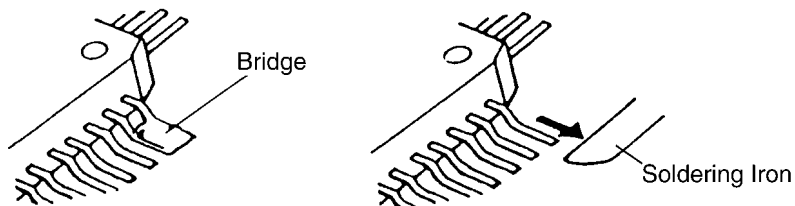

## 8.3. TEST CHART

### 8.3.1. ITU-T No.1 TEST CHART



## THE SLEREXE COMPANY LIMITED

SAPORS LANE - BOOLE - DORSET - BH 25 8 ER

TELEPHONE BOOLE (945 13) 51617 - TELEX 123456

Our Ref. 350/PJC/EAC

18th January, 1972.

Dr. P.N. Cundall,  
Mining Surveys Ltd.,  
Holroyd Road,  
Reading,  
Berks.

Dear Pete,

Permit me to introduce you to the facility of facsimile transmission.

In facsimile a photocell is caused to perform a raster scan over the subject copy. The variations of print density on the document cause the photocell to generate an analogous electrical video signal. This signal is used to modulate a carrier, which is transmitted to a remote destination over a radio or cable communications link.

At the remote terminal, demodulation reconstructs the video signal, which is used to modulate the density of print produced by a printing device. This device is scanning in a raster scan synchronised with that at the transmitting terminal. As a result, a facsimile copy of the subject document is produced.

Probably you have uses for this facility in your organisation.

Yours sincerely,

A handwritten signature in cursive script that reads "Phil."

P.J. CROSS  
Group Leader - Facsimile Research

### 8.3.2. ITU-T No.2 TEST CHART

CCITT N° 2 : Mire pour test de Transmission

<p>23</p> <p>24</p> <p>25</p> <p>26</p> <p>27</p>	<p>28</p>
<p>29</p>	<p>29</p>
<p>30</p>	<p>30</p>
<p>31</p>	<p>31</p>
<p>32</p>	<p>32</p>
<p>33</p>	<p>33</p>
<p>34</p>	<p>34</p>
<p>35</p>	<p>35</p>



# 9 FIXTURES AND TOOLS

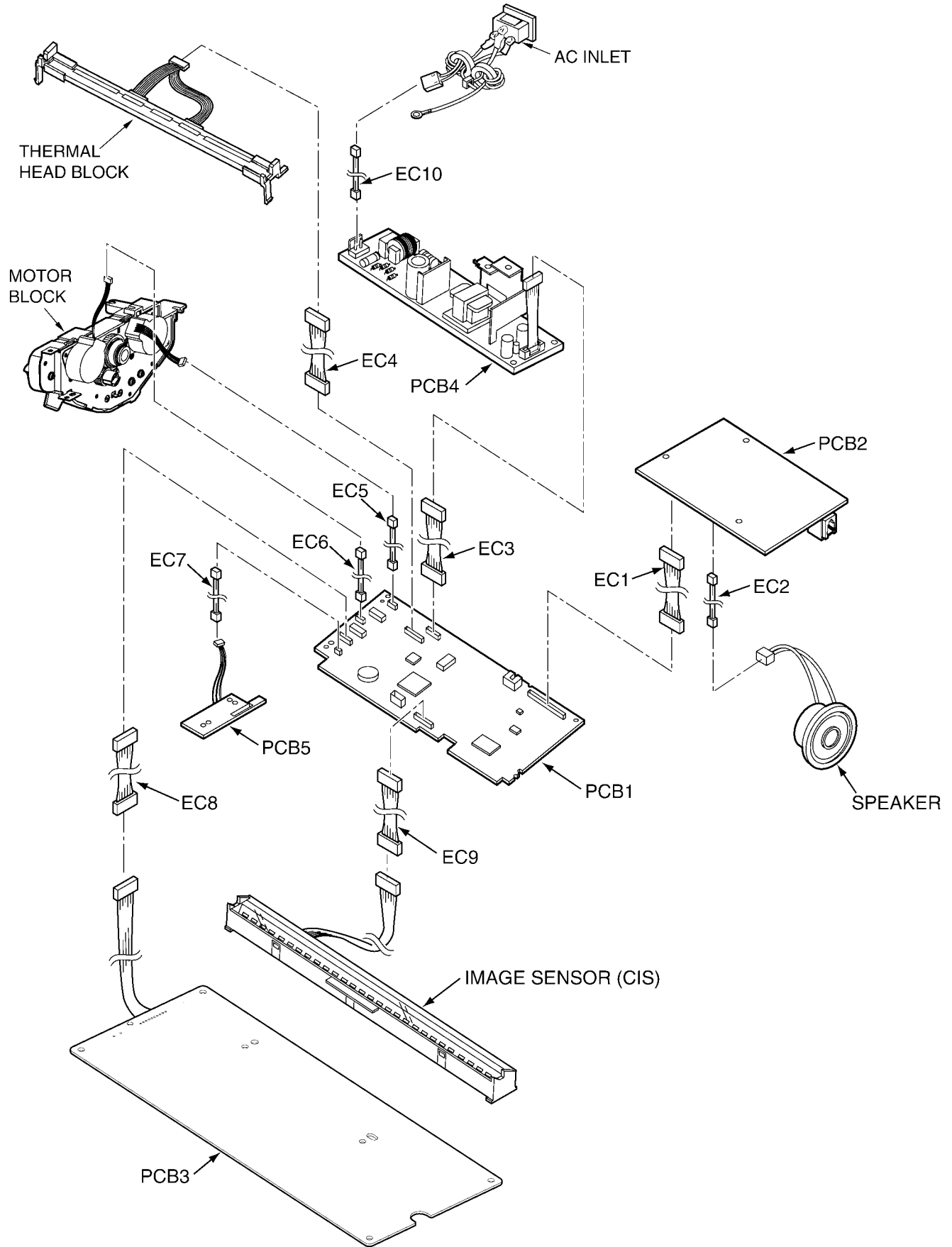

# 10 CABINET, MECHANICAL AND ELECTRICAL PARTS LOCATION

## 10.1. GENERAL SECTION

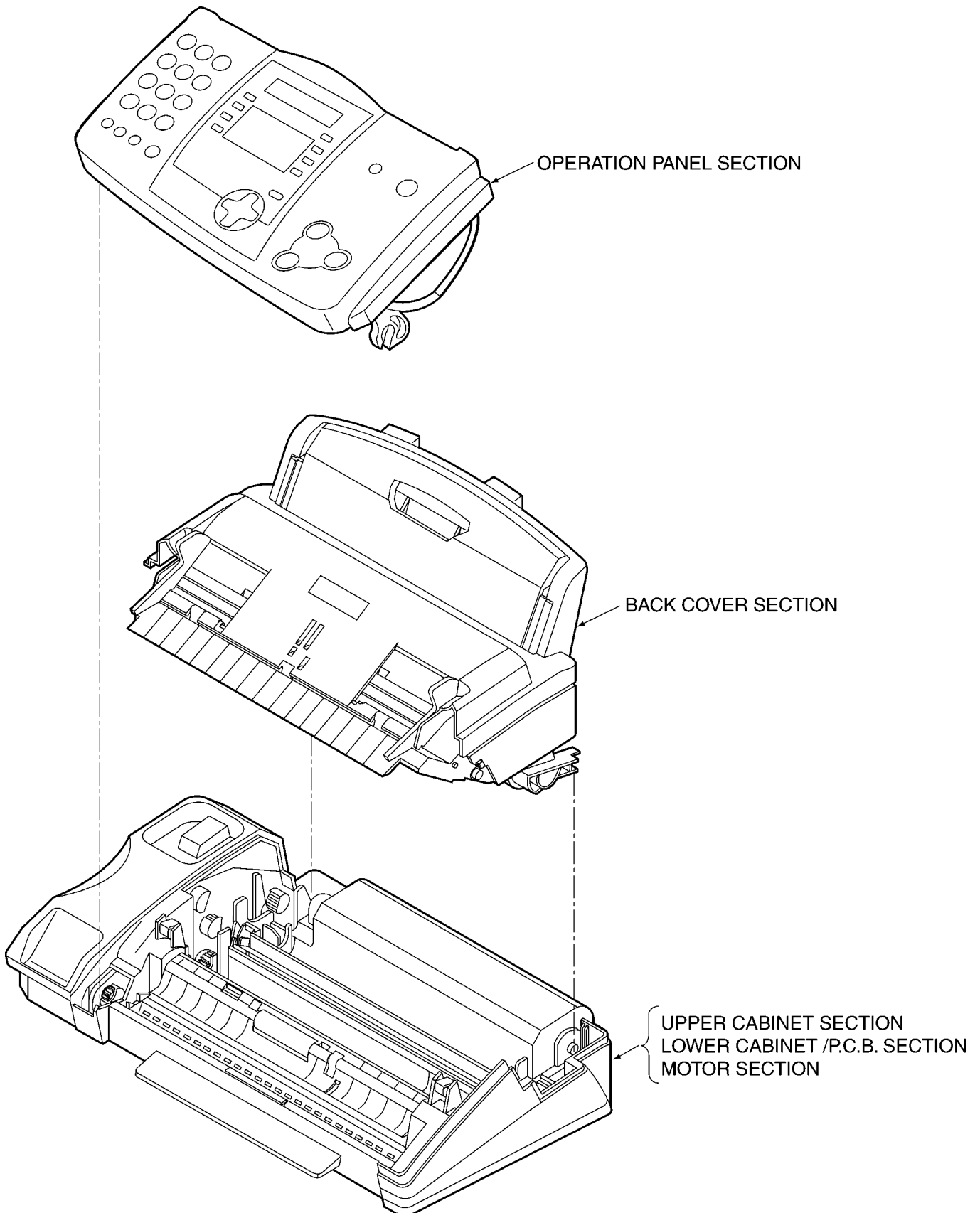

## 10.2. OPERATION PANEL SECTION

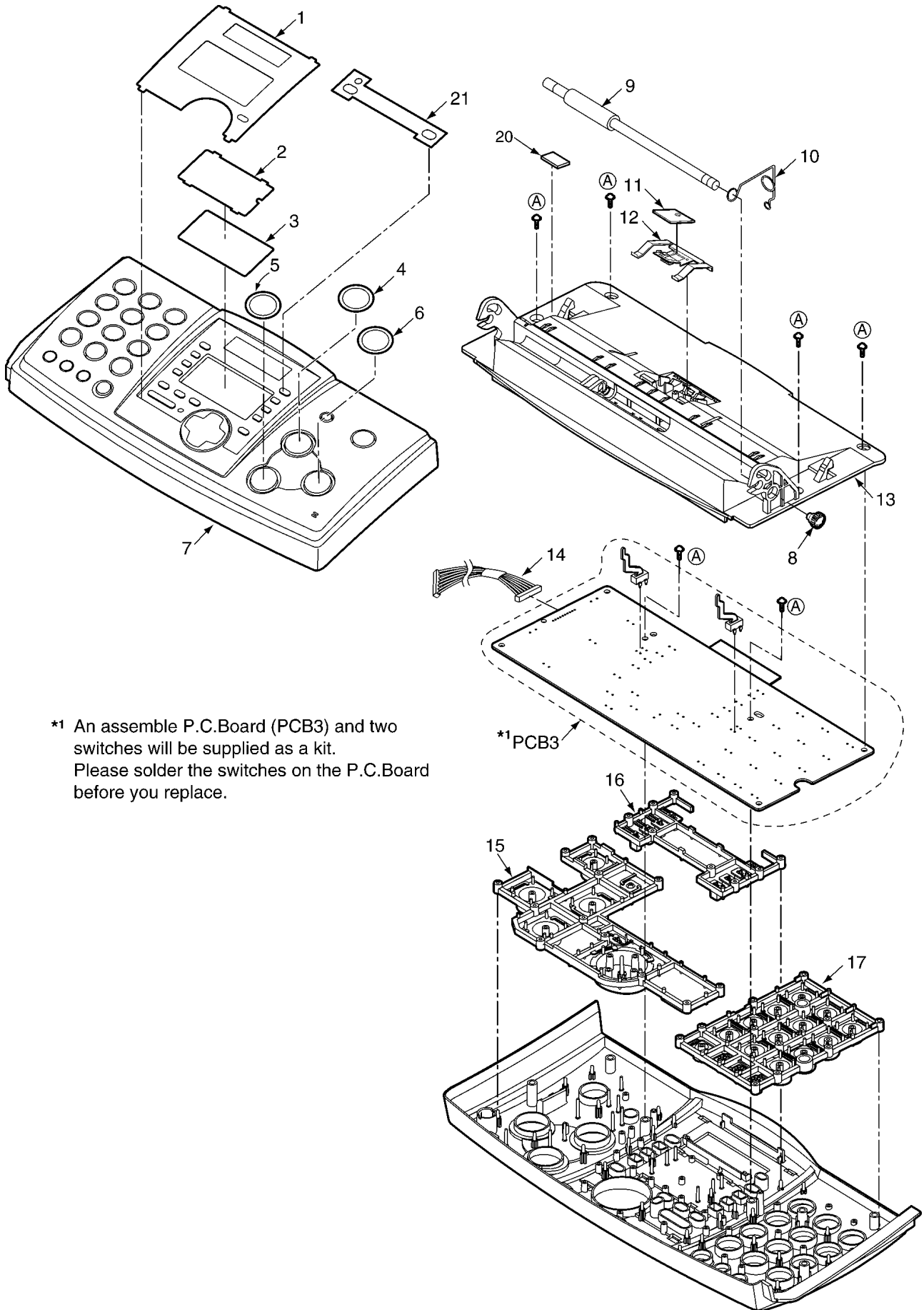

### 10.3. BACK COVER SECTION

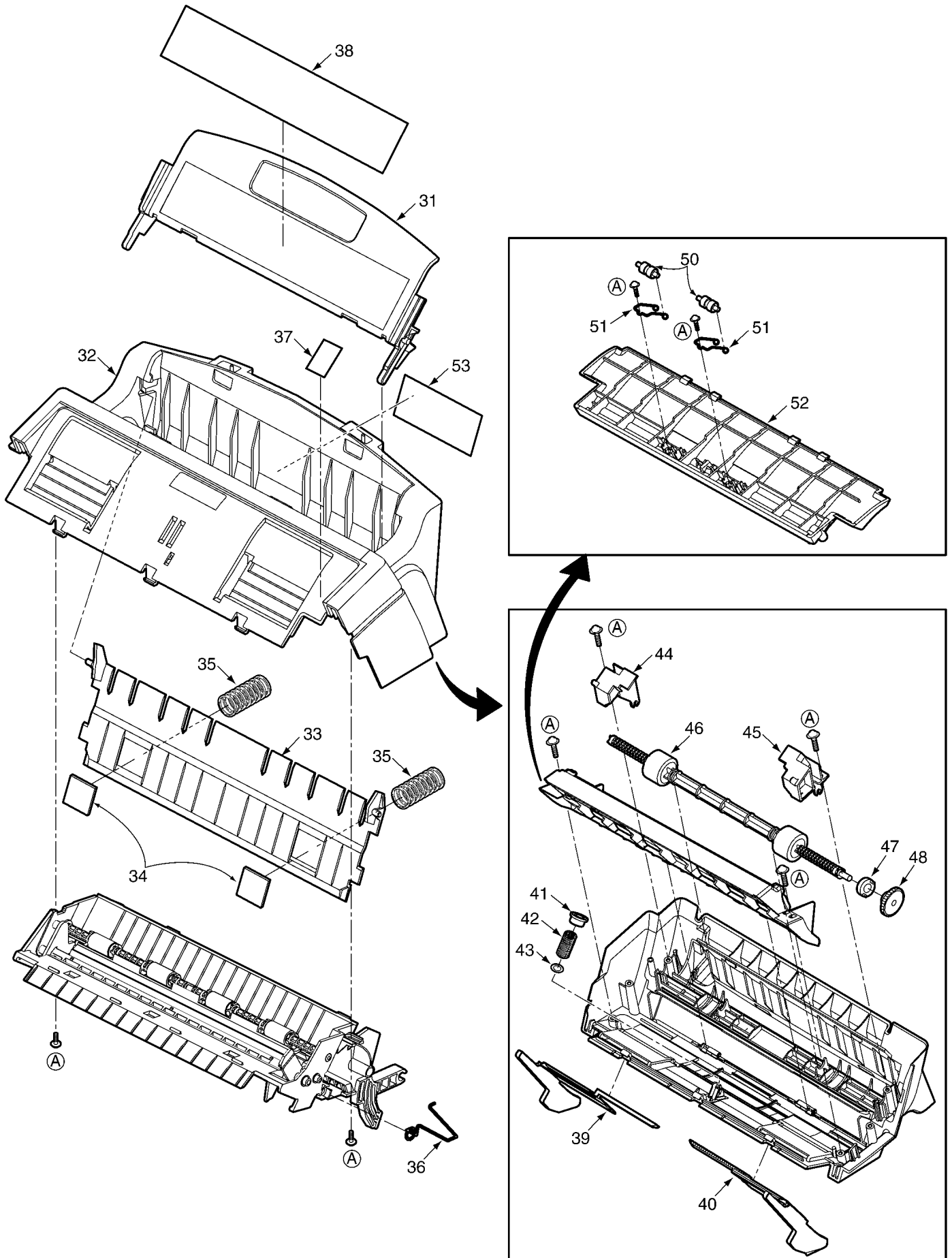

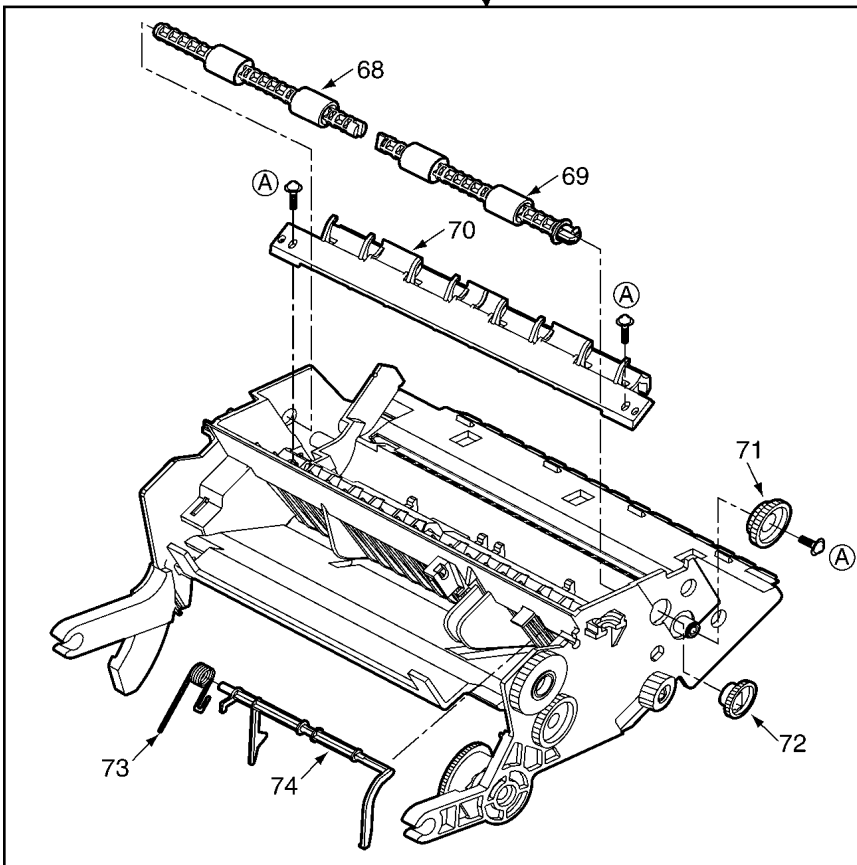
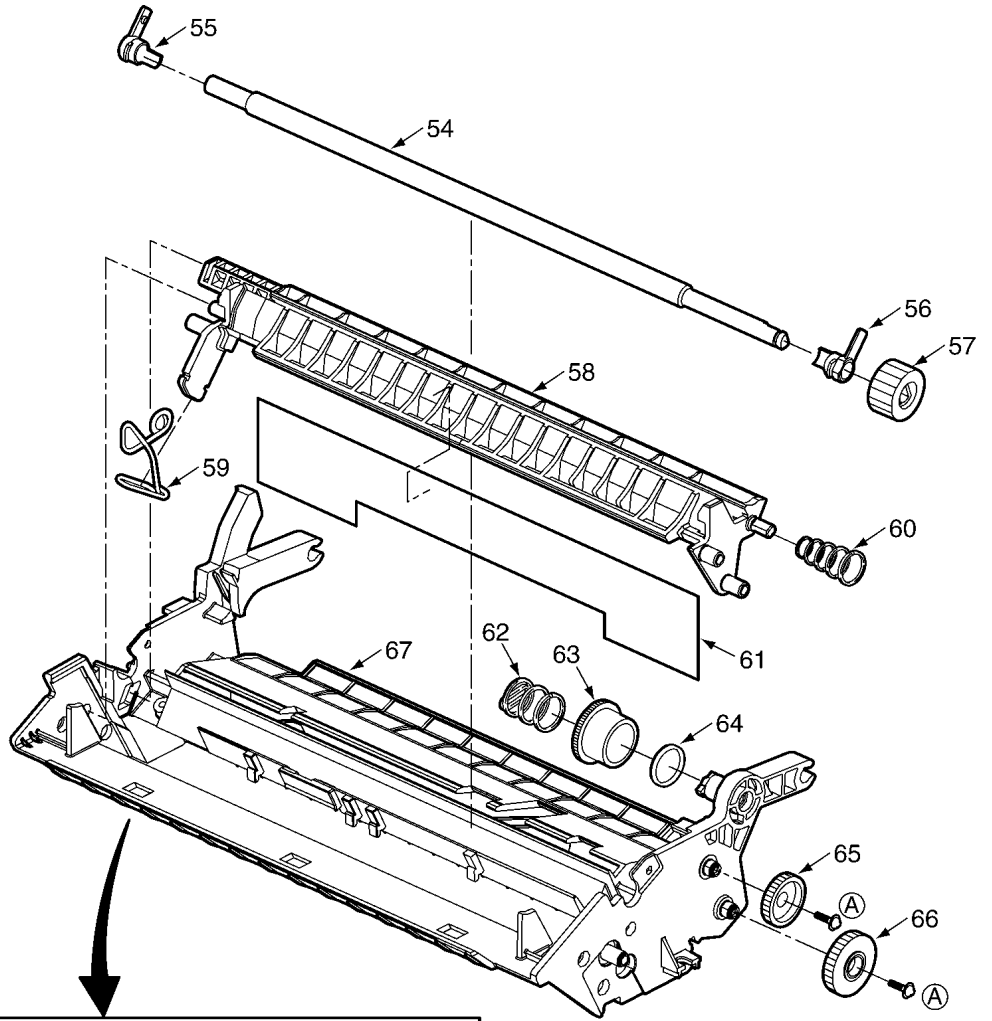

### 10.4. UPPER CABINET SECTION

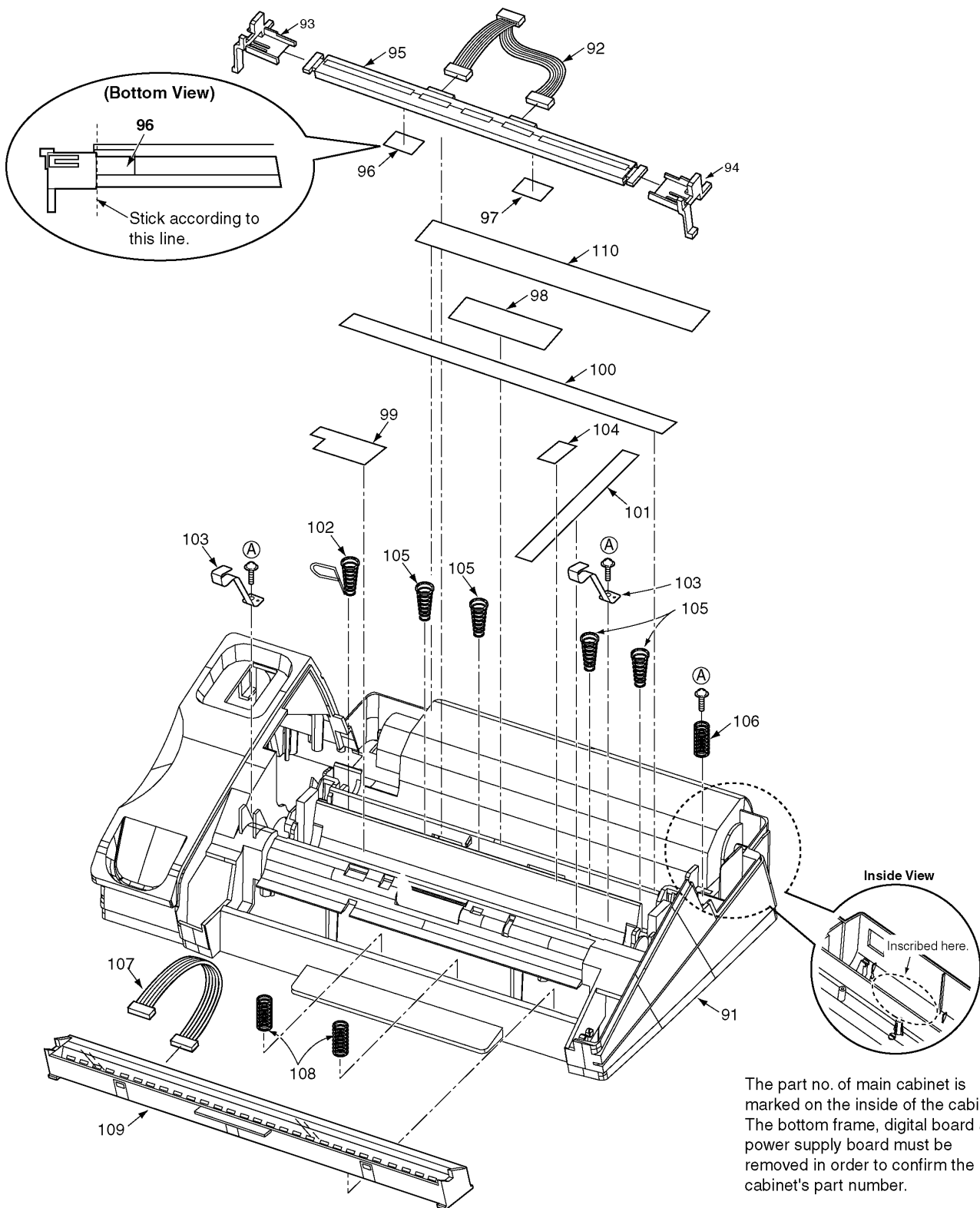

# 10.5. LOWER CABINET / P.C.BOARD SECTION

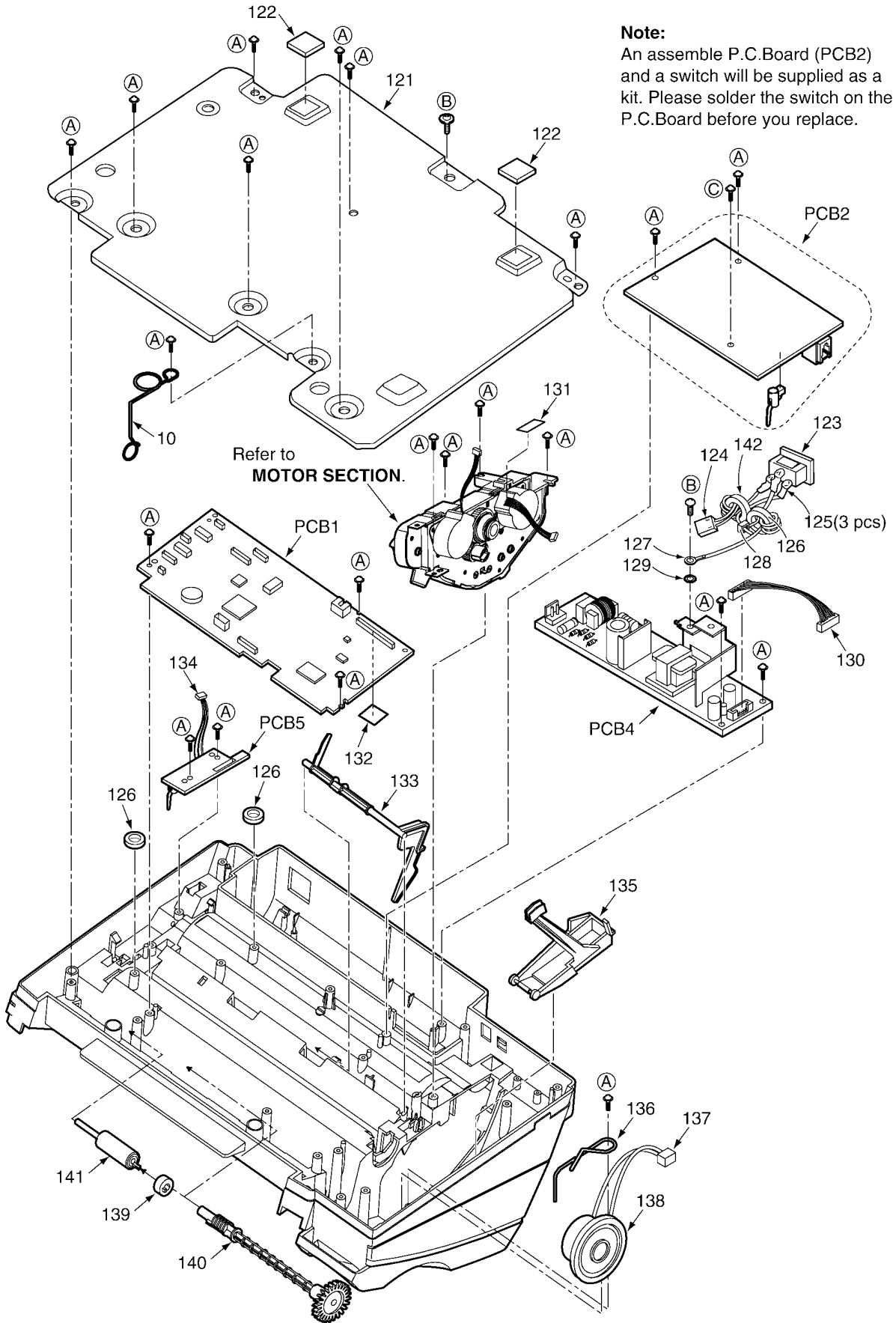



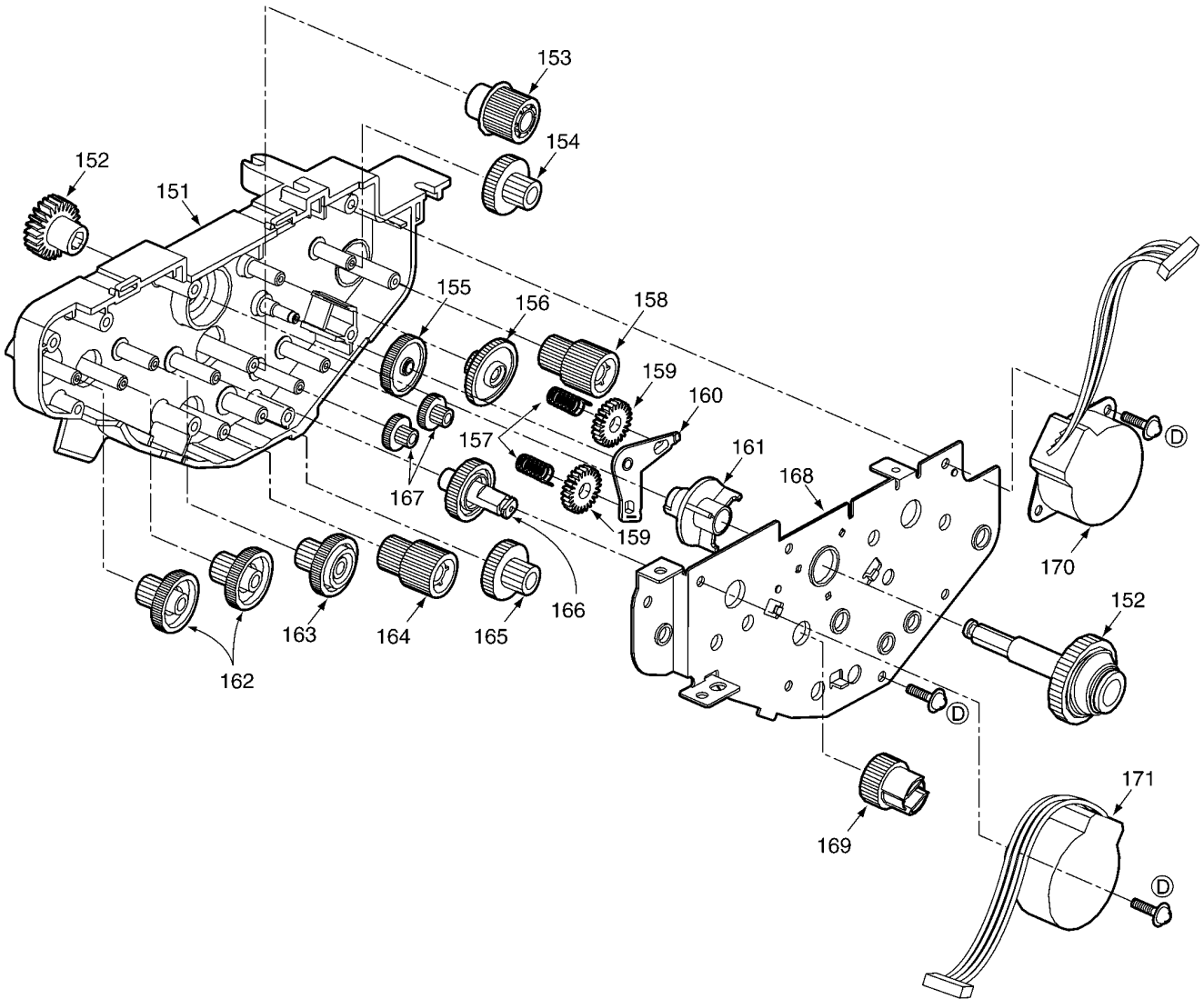

**CROSS REFERENCE:**  
MOTOR SECTION (P.171)

### 10.6. MOTOR SECTION

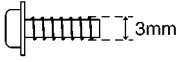

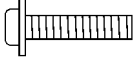
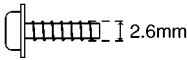
### 10.7. ACTUAL SIZE OF SCREWS

	Part No.	Illustration
(A)	XTW3+S10P	 3mm
(B)	XSB4+6	
(C)	XTW3+U14L	
(D)	XTW26+10P	 2.6mm
(E)	XTW3+W10P	



# 11 ACCESSORIES AND PACKING MATERIALS

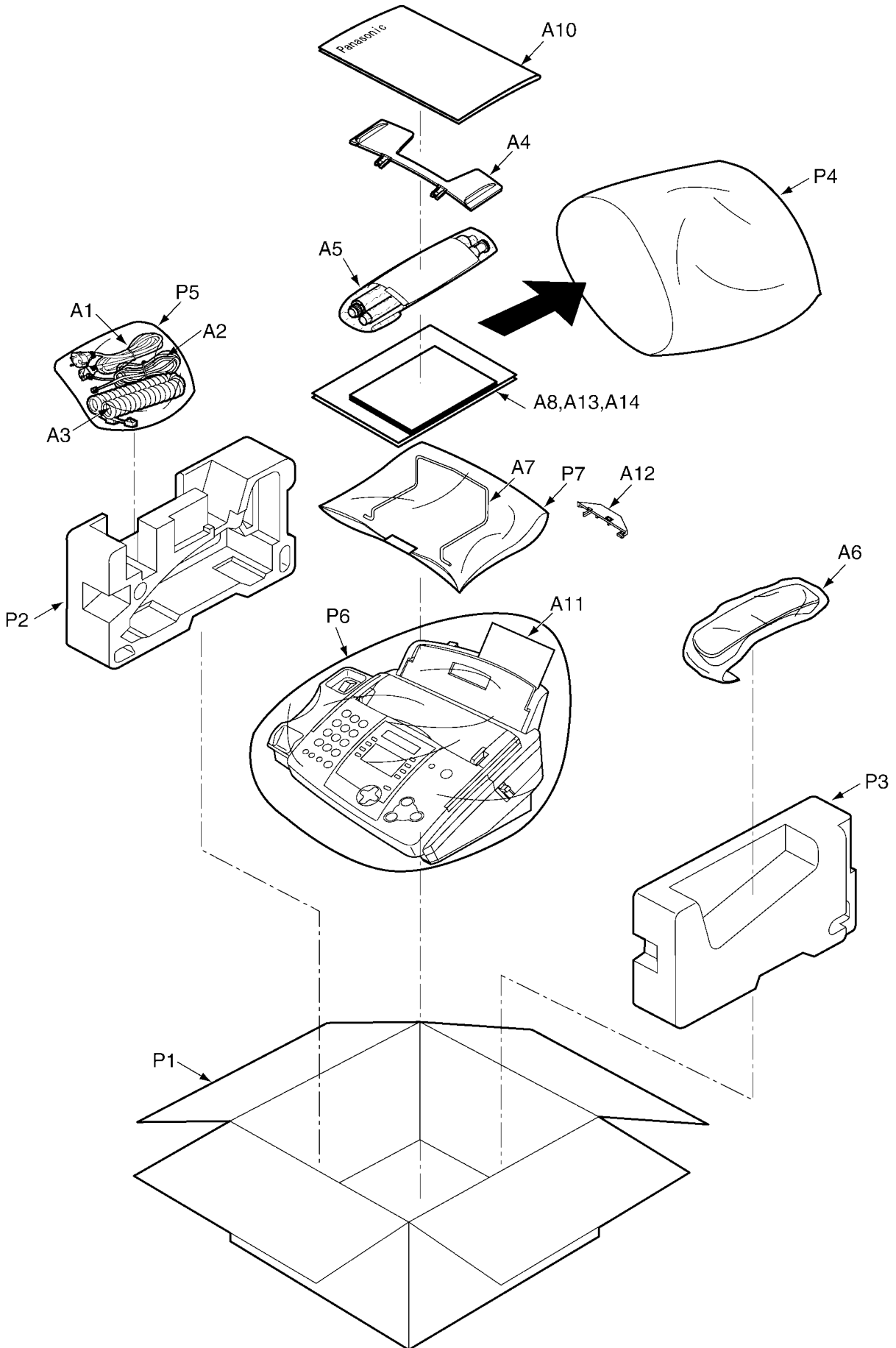

# 12 REPLACEMENT PARTS LIST

## 1. RTL (Retention Time Limited)

Note:

The marking (RTL) indicates that the Retention Time is limited for this item.

After the discontinuation of this assembly in production, the item will continue to be available for a specific period of time. The retention period of availability is dependent on the type of assembly, and in accordance with the laws governing parts and product retention.

After the end of this period, the assembly will no longer be available.

## 2. Important safety notice

Components identified by  $\triangle$  mark have special characteristics important for safety. When replacing any of these components, use only manufacture's specified parts.

3. The S mark means the part is one of some identical parts. For that reason, it may be different from the installed part.

4. ISO code (Example: ABS-HB) of the remarks column shows quality of the material and a flame resisting grade about plastics.

## 5. RESISTORS & CAPACITORS

Unless otherwise specified;

All resistors are in ohms ( $\Omega$ ) K=1000 $\Omega$ , M=1000k $\Omega$

All capacitors are in MICRO FARADS ( $\mu$ F) P= $\mu$ F

\*Type & Wattage of Resistor

Type

ERC:Solid	ERX:Metal Film	PQRD:Carbon
ERD:Carbon	ERG:Metal Oxide	PQRQ:Fuse
PQ4R:Chip	ERO:Metal Film	ERF:Wire Wound

Wattege

10,16,18:1/8W	14,25,S2:1/4W	12,50,S1:1/2W	1:1W	2:2W	5:5W
---------------	---------------	---------------	------	------	------

ECFD:Semi-Conductor	ECCD,ECKD,PQCBC,PQVP : Ceramic
ECQS:Styrol	ECQM,ECQV,ECQE,ECQU,ECQB : Polyester
PQCBX,ECUV:Chip	ECEA,ECSZ,ECOS : Electrolytic
ECMS:Mica	ECQP : Polypropylene

Voltage

ECQ Type	ECQG ECQV Type	ECSZ Type	Others		
1H : 50V	05 : 50V	OF : 3.15V	OJ : 6.3V	1V : 35V	
2A : 100V	1 : 100V	1A : 10V	1A : 10V	50,1H : 50V	
2E : 250V	2 : 200V	1V : 35V	1C : 16V	1J : 63V	
2H : 500V		OJ : 6.3V	1E,25 : 25V	2A : 100V	

## 12.1. CABINET AND ELECTRICAL PARTS

### 12.1.1. OPERATION PANEL SECTION

Ref. No.	Part No.	Part Name & Description	Remarks
1	PFGP1220V	PANEL, LCD	
2	PFGV1014Z	TRANSPARENT PLATE	
3	PFGD1049Z	CARD, TEL.	
4	PFHX1616Z	PLASTIC PARTS, RING COPY	
5	PFHX1618Z	PLASTIC PARTS, RING STOP	
6	PFHX1617Z	PLASTIC PARTS, RING START	
7	PFGG1199X1	GRILLE, OPERATION PANEL	PS-HB
8	PFDG1148Z	GEAR, DOCUMENT EXIT ROLLER	POM-HB
9	PFDN1040Z	ROLLER, DOCUMENT EXIT	

Ref. No.	Part No.	Part Name & Description	Remarks
10	PFUS1405Z	TORSION SPRING, EARTH	
11	PFHG1075Z	RUBBER PARTS, DOC. SEPARATION	
12	PFUS1417Z	LEAF SPRING, DOC. SEPARATION	
13	PFUV1054W	COVER, OPERATION PANEL	PS-HB
14	PFJS08Q86Z	CONNECTOR, 8 PIN	
15	PFBX1181Y1	PUSH BUTTON, START	ABS-HB
16	PFBX1180Z1	PUSH BUTTON, DIRECTION	ABS-HB
17	PFBX1179X1	PUSH BUTTON, DIAL	ABS-HB
18	Not Used		
19	Not Used		
20	PFHX1620Z	SPACER, SHEET	
21	PFHX1630Z	SPACER, LCD SHEET	

### 12.1.2. BACK COVER SECTION

Ref. No.	Part No.	Part Name & Description	Remarks
31	PFDE1189Y1	LEVER, CASSETTE	PS-HB
32	PFKV1071Y1	COVER, U TURN	PS-HB
33	PFKS1039W	TRAY, CASSETTE PLATE	PS-HB
34	PFHG1088Z	RUBBER PARTS, PAPER SEPARATION	
35	PFUS1414Z	TORSION SPRING, PICK UP	
36	PFUS1409Z	TORSION SPRING, EARTH	
37	PFQT1945Z	INDICATION LABEL, OPEN	
38	PFQT1932N	INDICATION LABEL, PAPER SET	
39	PFKR1028Y1	GUIDE, DOCUMENT/R	ABS-HB
40	PFKR1027X1	GUIDE, DOCUMENT/L	ABS-HB
41	PFDG1293Z	GEAR, DOCUMENT	POM-HB
42	PFUS1034Z	TORSION SPRING, GUIDE DOC.	
43	PFHX1605Z	SPACER, SLIDER GEAR SHEET	
44	PFHR1188Y	GUIDE, CORNER/R	POM-HB
45	PFHR1187Y	GUIDE, CORNER/L	POM-HB
46	PFDN1062Z	ROLLER, PICK UP	POM-HB
47	PFDE1188Z	SPACER, PICK UP DELAY	POM-HB
48	PFDG1290Z	GEAR, PICK UP ROLLER	POM-HB
49	Not Used		
50	PFDR1040Z	ROLLER, SUPPORT	
51	PFUS1407Y	TORSION SPRING, EXIT SUB ROLLER	
52	PFUV1055Y	COVER, GUIDE	PS-HB
53	PFGT2188Z-M	NAME PLATE, AL	S
54	PFDN1043Z	ROLLER, PLATEN	
55	PFDJ1029Z	SPACER, PLATEN/L	POM-HB
56	PFDJ1030Z	SPACER, PLATEN/R	POM-HB
57	PFDG1165Y	GEAR, PLATEN	POM-HB
58	PFDE1192Y1	LEVER, LOCK	ABS-GF20-HB
59	PFUS1404Z	TORSION SPRING, EARTH LEVER	
60	PFUS1258Z	COIL SPRING, LOCK LEVER	
61	PFHX1596Z	SPACER, LOCK LEVER SHEET	
62	PFUS1232Z	COIL SPRING, BACK TENSION	
63	PFDG1160Z	GEAR BACK TENSION	POM-HB
64	PFHS1029Z	COVER, BACK TENSION	
65	PFDG1291Z	GEAR, PICK UP IDLER	POM-HB
66	PFDG1292Z	GEAR, PICK UP IDLER	POM-HB
67	PFUA1042Y	CHASSIS, U TURN	PS-HB
68	PFDN1060Z	ROLLER, EXIT/L	POM-HB
69	PFDN1061Z	ROLLER, EXIT/R	POM-HB
70	PFUG1015Z	GUIDE, BASE	PS-HB
71	PFDG1289Z	GEAR, EXIT IDLER	POM-HB
72	PFDG1288Z	GEAR, EXIT ROLLER	POM-HB
73	PFUS1237Z	COIL SPRING, PAPER TOP	
74	PFDE1194Z	LEVER, PAPER TOP SENSOR	POM-HB

### 12.1.3. UPPER CABINET SECTION

Ref. No.	Part No.	Part Name & Description	Remarks
91	PFKML103V1	CABINET BODY, MAIN	PS-V0
92	PFJS11Q69Y	CONNECTOR, 11 PIN	
93	PFHR1373Z	GUIDE, HOLDER HEAD/L	POM-HB
94	PFHR1374Z	GUIDE, HOLDER HEAD/R	POM-HB
95	PFJHS026Z	PRINTER UNITS, THERMAL HEAD	S
96	PFHX1606Z	SPACER, HEAD SHEET	
97	PFHX1607Z	SPACER, HEAD SHEET	
98	PFHX1608Z	SPACER, RIBBON GUIDE SHEET	
99	PFQT2089Z	INDICATION LABEL, BLUE GEAR	
100	PFHX1462Z	COVER, STATIC ELEC. SHEET	
101	PFHX1344Z	INSULATOR, STATIC ELEC. SHEET	
102	PFUS1335Z	TORSION SPRING, HEAD	
103	PFUS1418Z	TORSION SPRING, OPERATION PANEL LOCK	
104	PFHX1491Z	SPACER, JOINT SHEET	
105	PFUS1235Z	COIL SPRING, HEAD	
106	PFUS1254Z	COIL SPRING, POP UP	
107	PFJS10Q72Z	CONNECTOR, 10 PIN	
108	PFUS1233Z	COIL SPRING, CIS	
109	N2GZBE000004	IMAGE SENSOR, CIS	
110	PFQT1934Z	INDICATION LABEL, INK FILM	

### 12.1.4. LOWER CABINET / P.C.B. SECTION

Ref. No.	Part No.	Part Name & Description	Remarks
121	PFMD1063Y	FRAME, BOTTOM	
122	PFHG1050Z	RUBBER PARTS, LEG	
123	PFJP03S04Z	CONNECTOR, 3 PIN	△
124	PFJS02R19Y	CONNECTOR, 2 PIN	
125	PQMX10010Z	COVER, SUMI TUBE	
126	PQLB1E1	INSULATOR, FERRITE CORE	S
127	WLR18YK26CM4	LEAD WIRE, EARTH	S
128	PQHR945Z	BAND	
129	XWC4B	WASHER	
130	PFJS07Q67Z	CONNECTOR	
131	PFHX1350Z	SPACER, HEAD SHEET	
132	PFHX1588Z	SPACER, DIGITAL SHEET	
133	PFDE1191Y	LEVER, PAPER TOP SENSOR	POM-HB
134	PFJS03Q47Z	CONNECTOR, 3 PIN	
135	PFBH1022Y1	PUSH BUTTON, HOOK	ABS-HB
136	PFUS1338Y	TORSION SPRING, SPEAKER	
137	PFJS02Q68Z	CONNECTOR, 2 PIN	
138	PFAS50P006Z	SPEAKER	S
139	PFDE1133Z	SPACER, DELAY	POM-HB
140	PFDF1087Z	SHAFT, DOC. SEPARATION	POM-HB
141	PFDR1014Z	ROLLER, DOC. SEPARATION	
142	KR06TT251508	INSULATOR, FERRITE CORE	S

### 12.1.5. MOTOR SECTION

Ref. No.	Part No.	Part Name & Description	Remarks
151	PFUA1041Y	CHASSIS, GEAR BASE	PBT+ABS -V1
152	PFDX1022Z	GEAR ASS'Y, TORQUE LIMIT	POM-HB
153	PFDG1151Z	GEAR	POM-HB
154	PFDG1287Z	GEAR	POM-HB
155	PFDG1150Z	GEAR	POM-HB
156	PFDG1149Z	GEAR	POM-HB
157	PFUS1231Y	COIL SPRING	
158	PFDG1158Z	GEAR	POM-HB
159	PFDG1159Z	GEAR	POM-HB
160	PFHR1355Y	ARM	POM-HB
161	PFHR1186Z	SPACER, SUPPORT BASE	POM-HB
162	PFDG1282Z	GEAR	POM-HB
163	PFDG1283Z	GEAR	POM-HB
164	PFDG1284Z	GEAR	POM-HB
165	PFDG1285Z	GEAR	POM-HB

Ref. No.	Part No.	Part Name & Description	Remarks
166	PFDG1153Z	GEAR	POM-HB
167	PFDG1286Z	GEAR	POM-HB
168	PFMD1062Z	FRAME	
169	PFDG1154Z	GEAR	POM-HB
170	35S1S15DGNH	DC MOTOR, RX	
171	35S1S15DGNF	DC MOTOR, TX	

### 12.1.6. ACCESSORIES AND PACKING MATERIALS

Ref. No.	Part No.	Part Name & Description	Remarks
A1	PQJA10038Y	POWER CORD	△
A2	PQJA10075Z	CORD, TELEPHONE	S
A3	PFJA04C002Z	CORD, HANDSET	
A4	PFKS1076Z1	TRAY, RECORDING PAPER	PS-HB
A5	PFPE1243Z	ACCESSORY PARTS, INK RIBBON (70M)	
A6	PFJXE0805Z	HANDSET ASS'Y	S
A7	PFUS1406Z	TRAY, RECORDING PAPER SUPPORT	
A8	PFQX1830Z	INSTRUCTION BOOK	
A9	Not Used		
A10	PFQW1942Z	INSTRUCTION BOOK, QUICK START SHEET	
A11	PFHP1114Z	LEAFLET, PROTECTION PAPER	
A12	PFKS1080Z1	TRAY, A4 SPACER	
A13	PFQW1943Z	LEAFLET (ARABIC)	
A14	PFQW1944Z	LEAFLET (PERSIA)	
P1	PFPE1406Z-M	GIFT BOX	S
P2	PFPN1286Z	CUSHION, LEFT	
P3	PFPN1287Z	CUSHION, RIGHT	
P4	XZB32X45A04	PROTECTION COVER	
P5	XZB20X35A04	PROTECTION COVER	
P6	PFPH1011Z	PACKING SHEET	
P7	XZB20X30A04	PROTECTION COVER	

### 12.2. DIGITAL BOARD PARTS

Ref. No.	Part No.	Part Name & Description	Remarks
PCB1	PFWP1FP342BX	DIGITAL BOARD ASS'Y (RTL)	
		(ICs)	
IC501	C1ZBZ0001896	IC	
IC503	PFVIMS5148EF	IC	S
IC505	PFVIR676812	IC	
IC507	PFVII5510011	IC	
IC508	PFVIT2003APS	IC	S
IC509	PQVITC4066BF	IC	S
IC510	PFVIT2003APS	IC	S
IC511	PFVINJM4558M	IC	S
IC520	C1ZBZ0002029	IC	
IC523	PFWIFP342BX	IC (ROM)	
		(TRANSISTORS)	
Q501	PQVTDTC143E	TRANSISTOR (SI)	S
Q502	2SB1322	TRANSISTOR (SI)	S
Q503	PQVTDTC143E	TRANSISTOR (SI)	S
Q504	2SB1322	TRANSISTOR (SI)	S
Q505	2SD1819A	TRANSISTOR (SI)	S
Q506	2SD1819A	TRANSISTOR (SI)	S
Q507	PQVTDTC143E	TRANSISTOR (SI)	S
Q508	2SD1819A	TRANSISTOR (SI)	S
Q509	2SD1819A	TRANSISTOR (SI)	S
Q510	PQVTDTC114EU	TRANSISTOR (SI)	S
Q511	2SD1819A	TRANSISTOR (SI)	S
Q514	2SB1218A	TRANSISTOR (SI)	
Q517	PQVTDTC143E	TRANSISTOR (SI)	S
Q518	2SD1819A	TRANSISTOR (SI)	S
Q524	PQVTDTC114EU	TRANSISTOR (SI)	S

Ref. No.	Part No.	Part Name & Description	Remarks
Q525	UN5113	TRANSISTOR(SI)	S
Q526	PQVTDTC143E	TRANSISTOR(SI)	S
IC506	PFVTSI4431DY	TRANSISTOR(SI)	S
		(DIODES)	
D501	PFVDRMRLS245	DIODE(SI)	S
D502	MA7160	DIODE(SI)	
D503	RLS71	DIODE(SI)	
D504	PFVDRMRLS245	DIODE(SI)	S
D505	MA7160	DIODE(SI)	
		(BATTERY)	
BAT501	PFSU1004Z	LITHIUM BATTERY	S
		(CONNECTORS)	
CN503	PQJP10G30Z	CONNECTOR, 10 PIN	S
CN504	PQJP8G30Z	CONNECTOR, 8 PIN	S
CN505	PQJP11G30Z	CONNECTOR, 11 PIN	S
CN506	PQJP7G30Y	CONNECTOR, 7 PIN	S
CN508	PQJS08X54Z	CONNECTOR, 8 PIN	
CN512	PQJP3G30Y	CONNECTOR, 3 PIN	S
CN515	PQJP5G30Y	CONNECTOR, 5 PIN	S
CN516	PQJP05G100Z	CONNECTOR, 5 PIN	
CN517	PQJP16A19Z	CONNECTOR, 16 PIN	S
		(FUSE RESISTORS)	
F503	PFRB0031125T	FUSE RESISTOR	S
F504	PFRB0031125T	FUSE RESISTOR	S
		(CERAMIC FILTERS)	
L506	PFVF1A121ST	CERAMIC FILTER	
L514	PFVF1A121ST	CERAMIC FILTER	
		(COILS)	
L512	PQLQR2KA20T	COIL	S
L519	PQLQR2KA113	COIL	S
L522	PQLQR2KA20T	COIL	S
L531	PQLQR2KA20T	COIL	S
L532	PQLQR2KA113	COIL	S
L533	PQLQR2KA113	COIL	S
		(COMPONENTS COMBINATIONS)	
RA506	EXB38V271JV	RESISTOR ARRAY	
RA509	EXB38V101JV	RESISTOR ARRAY	
RA510	EXB38V101JV	RESISTOR ARRAY	
RA511	EXB38V271JV	RESISTOR ARRAY	
RA513	EXB38V103JV	RESISTOR ARRAY	
RA514	EXB38V101JV	RESISTOR ARRAY	
RA515	EXB38V101JV	RESISTOR ARRAY	
RA516	EXB38V101JV	RESISTOR ARRAY	
RA517	EXB38V101JV	RESISTOR ARRAY	
		(CRYSTAL OSCILLATORS)	
X501	PFVCCFS32Z	CRYSTAL OSCILLATOR	S
X502	PFVBKB240ZAT	CRYSTAL OSCILLATOR	S
X503	PFVC32256ZAT	CRYSTAL OSCILLATOR	S
		(PHOTO ELECTRIC TRANSDUCER)	
PS501	PFVISG257	PHOTO SENSOR	S
		(RESISTORS)	
L501	ERJ3GEYJ101	100	
L502	ERJ3GEYJ101	100	
L503	ERJ3GEYJ101	100	
L504	ERJ3GEYJ101	100	
L505	ERJ3GEYJ101	100	
L507	ERJ3GEY0R00	0	
L509	ERJ3GEY0R00	0	
L510	ERJ3GEY0R00	0	
L515	ERJ3GEY0R00	0	
L516	ERJ3GEYJ101	100	
L517	ERJ3GEYJ101	100	
L518	ERJ3GEY0R00	0	

Ref. No.	Part No.	Part Name & Description	Remarks
L520	ERJ3GEY0R00	0	
L525	ERJ3GEYJ101	100	
L526	ERJ3GEYJ101	100	
L527	ERJ3GEYJ101	100	
L528	ERJ3GEYJ101	100	
L529	ERJ3GEYJ101	100	
L530	ERJ3GEY0R00	0	
R501	ERJ3GEYJ562	5.6k	
R502	ERJ3GEYJ472	4.7k	
R503	ERJ3GEYJ101	100	
R504	ERJ3GEYJ181	180	
R505	ERJ3GEYJ101	100	
R506	ERJ3GEYJ181	180	
R507	ERJ3GEYJ101	100	
R510	ERJ3GEYJ101	100	
R511	ERJ3GEYJ101	100	
R512	ERJ3GEYJ101	100	
R513	ERJ3GEYJ102	1k	
R515	ERJ3GEYJ101	100	
R517	ERJ3GEYJ101	100	
R518	ERJ3GEY0R00	0	
R519	ERJ3GEYJ821	820	
R520	ERD51VJ152	1.5k	S
R522	ERJ3GEYJ223	22k	
R523	ERJ3GEYJ433	43k	
R526	ERJ3EKF1101	1.1k	
R529	ERJ3EKF3602	36k	
R531	ERJ3GEYJ334	330k	
R532	ERJ3GEYJ475	4.7M	
R533	ERJ3GEYJ203	20k	
R534	ERJ3GEY0R00	0	
R535	ERJ3GEYJ821	820	
R536	ERD51VJ152	1.5k	S
R538	ERJ3GEYJ101	100	
R539	ERJ3GEYJ101	100	
R540	ERJ3GEYJ101	100	
R541	ERJ3GEYJ101	100	
R542	ERJ3GEYJ101	100	
R543	ERJ3GEYJ101	100	
R544	ERJ3GEYJ222	2.2k	
R545	ERJ3GEYJ471	470	
R548	ERJ3GEYJ103	10k	
R549	ERJ3GEYJ101	100	
R550	ERJ3GEYJ103	10k	
R551	ERJ3GEYJ101	100	
R552	ERJ3GEYJ470	47	
R553	ERJ3GEYJ105	1M	
R554	ERJ3GEYJ472	4.7k	
R555	PQ4R18XJ220	22	S
R556	ERJ6GEYJ6R8	6.8	
R557	ERJ3GEYJ271	270	
R558	ERJ3GEYJ272	2.7k	
R559	ERJ3GEYJ103	10k	
R560	ERJ3GEYJ103	10k	
R561	ERJ3GEYJ472	4.7k	
R563	ERJ3GEYJ221	220	
R564	ERJ3GEYJ103	10k	
R565	ERJ3GEYJ222	2.2k	
R566	ERJ3GEYJ102	1k	
R567	ERJ3GEYJ102	1k	
R568	ERJ3GEYJ103	10k	
R569	ERJ3GEYJ683	68k	
R570	ERJ3GEYJ474	470k	
R571	ERJ3GEYJ105	1M	
R572	ERJ3GEYJ185	1.8M	
R573	ERJ3GEYJ222	2.2k	
R574	ERJ3GEYJ152	1.5k	
R575	ERJ3GEYJ103	10k	
R576	ERJ3GEYJ103	10k	
R577	ERJ3GEY0R00	0	
R579	ERJ3GEYJ303	30k	
R580	ERJ3GEYJ154	150k	

Ref. No.	Part No.	Part Name & Description	Remarks
R581	ERJ3GEYJ103	10k	
R582	ERJ3GEYJ102	1k	
R583	ERJ3GEYJ333	33k	
R584	ERJ3GEYJ392	3.9k	
R585	ERJ3GEYJ474	470k	
R586	ERJ3GEYJ153	15k	
R587	ERJ3GEYJ473	47k	
R589	ERJ3GEYJ224	220k	
R590	ERJ3GEYJ224	220k	
R591	ERJ3GEYJ103	10k	
R593	ERJ3GEYJ563	56k	
R594	ERJ3GEYJ682	6.8k	
R597	ERJ3GEYJ334	330k	
R600	ERJ3GEYJ473	47k	
R603	ERG2SJ391	390	
R614	ERJ3GEYJ472	4.7k	
R615	ERJ3GEYJ222	2.2k	
R619	ERJ3GEYJ104	100k	
R620	ERJ8GEYJ2R2	2.2	
R621	ERJ3GEYJ4R7	4.7	
R622	PQ4R10XJ331	330	S
R625	ERJ3GEYJ101	100	
R626	ERJ3GEYJ101	100	
R629	ERJ3GEYJ101	100	
R634	ERJ3GEY0R00	0	
R653	ERJ3GEYJ101	100	
R654	ERJ3GEYJ101	100	
R655	ERJ3GEYJ101	100	
R656	ERJ3GEYJ101	100	
R659	ERJ3GEYJ472	4.7k	
R662	ERJ3GEYJ472	4.7k	
R663	ERJ3GEYJ472	4.7k	
R677	ERJ3GEYJ331	330	
R678	ERJ3GEYJ563	56k	
R679	ERJ3GEYJ562	5.6k	
R680	ERJ3GEYJ472	4.7k	
R681	ERJ3GEYJ101	100	
R682	ERJ3GEYJ103	10k	
R683	ERJ3GEYJ472	4.7k	
R684	ERJ3GEYJ472	4.7k	
R685	ERJ3GEYJ101	100	
R688	ERJ3GEY0R00	0	
R699	ERJ3GEY0R00	0	
R700	ERJ3GEY0R00	0	
R701	ERJ3GEY0R00	0	
R702	ERJ3GEYJ102	1k	
R703	ERJ3GEYJ102	1k	
R704	ERJ3GEYJ102	1k	
R705	ERJ3GEYJ103	10k	
R719	ERJ3GEYJ472	4.7k	
R720	ERJ3GEYJ103	10k	
R721	ERJ3GEYJ103	10k	
R722	ERJ3GEYJ103	10k	
R723	ERJ3GEYJ103	10k	
R724	ERJ3GEYJ103	10k	
R725	ERJ3GEYJ103	10k	
R726	ERJ3GEYJ103	10k	
R727	ERJ3GEYJ103	10k	
R728	ERJ3GEYJ472	4.7k	
R731	ERJ3GEYJ103	10k	
R742	ERJ3GEYJ271	270	
R743	ERJ3GEYJ472	4.7k	
		(CAPACITORS)	
C502	ECUV1H104ZFV	0.1	S
C503	ECEA1CK101	100	S
C504	PQCUV1H104ZF	0.1	S
C509	ECUV1H102KBV	0.001	S
C510	ECUV1H104ZFV	0.1	S
C513	ECUV1H104ZFV	0.1	S
C514	ECUV1H104ZFV	0.1	S
C515	ECUV1H104ZFV	0.1	S
C516	ECUV1H104ZFV	0.1	S

Ref. No.	Part No.	Part Name & Description	Remarks
C517	ECUV1H104ZFV	0.1	S
C518	ECUV1H222KBV	0.0022	S
C519	ECUV1C104KBV	0.1	S
C522	ECUV1C104KBV	0.1	S
C523	ECUV1H150JCV	15P	S
C524	ECUV1H104ZFV	0.1	S
C525	ECUV1H150JCV	15P	S
C526	ECUV1H102KBV	0.001	S
C527	ECUV1H104ZFV	0.1	S
C529	ECUV1H104ZFV	0.1	S
C531	ECUV1H104ZFV	0.1	S
C533	ECUV1H104ZFV	0.1	S
C534	ECEA1CK101	100	S
C535	ECUV1H104ZFV	0.1	S
C536	ECUV1H104ZFV	0.1	S
C537	ECUV1H104ZFV	0.1	S
C538	ECUV1H104ZFV	0.1	S
C539	ECUV1H101JCV	100P	S
C540	ECUV1H100JCV	10P	S
C541	ECUV1H100JCV	10P	S
C542	ECUV1H104ZFV	0.1	S
C543	ECUV1H104ZFV	0.1	S
C545	ECUV1H104ZFV	0.1	S
C546	ECUV1H104ZFV	0.1	S
C547	ECUV1H104ZFV	0.1	S
C548	ECEA1CK101	100	S
C549	ECUV1C104KBV	0.1	S
C550	ECUV1H330JCV	33P	S
C551	ECEA1CK101	100	S
C553	ECUV1H472KBV	0.0047	S
C554	ECUV1H472KBV	0.0047	S
C559	ECUV1H104ZFV	0.1	S
C560	ECUV1H104ZFV	0.1	S
C564	ECEA1CKS100	10	S
C565	ECEA1CKS100	10	S
C566	ECUV1H104ZFV	0.1	S
C568	ECUV1H102KBV	0.001	S
C569	ECUV1H104ZFV	0.1	S
C570	ECUV1C273KBV	0.027	S
C571	ECUV1C104KBV	0.1	S
C572	ECUV1H103KBV	0.01	S
C573	ECUV1C104KBV	0.1	S
C575	ECUV1H104ZFV	0.1	S
C576	ECUV1C104KBV	0.1	S
C577	ECUV1H102KBV	0.001	S
C578	ECUV1H104ZFV	0.1	S
C579	ECUV1C104KBV	0.1	S
C580	ECUV1H390JCV	39P	S
C581	ECUV1H223KBV	0.022	S
C582	PQCUV1H104ZF	0.1	S
C583	ECUV1H104ZFV	0.1	S
C584	ECUV1H181JCV	180P	S
C585	ECUV1H104ZFV	0.1	S
C586	ECUV1C104KBV	0.1	S
C588	ECEA1HKS100	10	S
C589	ECUV1H104ZFV	0.1	S
C591	ECUV1H472KBV	0.0047	S
C592	ECUV1H472KBV	0.0047	S
C598	ECUV1H120JCV	12P	S
C599	ECUV1H100JCV	10P	S
C600	ECUV1H560JCV	56P	S
C601	ECUV1C104KBV	0.1	S
C604	ECUV1H102KBV	0.001	S
C605	ECUV1H104ZFV	0.1	S
C606	ECUV1H102KBV	0.001	S
C609	ECUV1H104ZFV	0.1	S
C610	ECUV1H104ZFV	0.1	S
C611	ECUV1H104ZFV	0.1	S
C614	ECUV1H104ZFV	0.1	S
C618	ECUV1H102KBV	0.001	S
C619	ECUV1H104ZFV	0.1	S
C620	ECUV1H104ZFV	0.1	S
C621	ECUV1H104ZFV	0.1	S

Ref. No.	Part No.	Part Name & Description	Remarks
C623	ECEA1CK101	100	S
C625	ECEA1CK101	100	S
C626	ECUV1H104ZFB	0.1	S
C628	ECUV1H104ZFB	0.1	S
C634	ECUV1H104ZFB	0.1	S
C635	ECUV1H104ZFB	0.1	S
C646	ECUV1C104KBV	0.1	S
C651	ECUV1H102KBV	0.001	S
C652	ECUV1H102KBV	0.001	S
C654	ECUV1H104ZFB	0.1	S
C655	ECUV1H104ZFB	0.1	S
C656	ECUV1H104ZFB	0.1	S
C670	ECUV1H102KBV	0.001	S

## 12.3. ANALOG BOARD PARTS

Ref. No.	Part No.	Part Name & Description	Remarks
PCB2	PFWP2HD333LS	ANALOG BOARD ASS'Y (RTL)	△
		(ICs)	
IC101	PQVINJM2904F	IC	S
IC102	PQVIMC34119M	IC	S
		(TRANSISTORS)	
Q101	2SD1819A	TRANSISTOR(SI)	S
Q102	PQVTDTC143E	TRANSISTOR(SI)	S
Q103	2SD1819A	TRANSISTOR(SI)	S
		(DIODES)	
D101	MA4056	DIODE(SI)	
D102	MA4056	DIODE(SI)	
D103	1SS119	DIODE(SI)	S
D105	1SS119	DIODE(SI)	S
D106	1SS119	DIODE(SI)	S
		(CONNECTORS AND JACKS)	
CN101	PQJS16A10Z	CONNECTOR, 16 PIN	S
CN102	PFJJ1T01Z	JACK	S
CN103	PFJJ1T01Z	JACK	S
CN104	PQJJ1TB18Z	JACK	S
CN105	PQJP02G100Z	CONNECTOR, 2 PIN	
		(SWITCH)	
SW101	PFSHA011Z	SWITCH, HOOK	
		(COILS)	
L102	PQLQR2KA213	COIL	S
L103	PQLQR2KA213	COIL	S
L104	PQLQR2KA213	COIL	S
L105	PQLQR2KA213	COIL	S
L107	PQLQR2KA113	COIL	S
L108	PQLQR2KA113	COIL	S
L109	PQLQR2KA113	COIL	S
L110	PQLQR2KA113	COIL	S
		(PHOTO ELECTRIC TRANSDUCERS)	
PC101	0N3181	PHOTO COUPLER	△
PC105	CNC7S102	PHOTO COUPLER	△
		(THERMISTOR)	
POS101	PQRPAR390N	POSISTOR	△ S
		(RELAY)	
RLY101	PFSL001Z	RELAY	△ S
		(VARISTORS)	
SA101	PQVDDSS301L	VARISTOR (SURGE ABSORBER)	S
SA102	PFRZ002Z	VARISTOR (SURGE ABSORBER)	△ S
		(TRANSFORMER)	
T101	G4A1A0000151	TRANSFORMER	△

Ref. No.	Part No.	Part Name & Description	Remarks
		(RESISTORS)	
R101	ERJ3GEYJ123	12k	
R102	ERJ3GEYJ682	6.8k	
R103	ERJ3GEYJ222	2.2k	
R105	ERG2SJ151	150	
R106	ERDS1TJ103	10k	S
R107	ERDS1TJ473	47k	S
R108	ERJ3GEYJ393	39k	
R109	ERDS2TJ221	220	S
R111	ERJ3GEYJ564	560k	
R112	ERJ3GEYJ124	120k	
R114	ERJ3GEYJ183	18k	
R115	ERJ3GEYJ124	120k	
R116	ERJ3GEYJ224	220k	
R117	ERJ3GEYJ224	220k	
R118	ERJ3GEYJ222	2.2k	
R119	ERJ3GEYJ334	330k	
R121	ERDS2TJ331	330	S
R123	ERJ3GEYJ333	33k	
R124	ERJ3GEYJ913	91k	
R125	ERJ3GEYJ0R00	0	
R131	ERJ3GEYJ101	100	
R132	ERJ3GEYJ473	47k	
R133	ERJ3GEYJ331	330	
R134	ERJ3GEYJ562	5.6k	
R136	ERJ3GEYJ152	1.5k	
R137	ERJ3GEYJ331	330	
R138	ERJ3GEYJ152	1.5k	
R139	ERJ3GEYJ183	18k	
R140	ERJ3GEYJ183	18k	
R141	ERJ3GEYJ394	390k	
R142	ERJ3GEYJ394	390k	
R143	ERJ3GEYJ222	2.2k	
R149	ERJ3GEYJ680	68	
R151	ERJ3GEYJ473	47k	
R164	ERJ3GEYJ101	100	
R165	ERJ3GEYJ472	4.7k	
R171	ERJ3GEYJ103	10k	
R172	ERJ3GEYJ103	10k	
R173	ERJ3GEYJ103	10k	
R175	ERJ3GEYJ114	110k	
R176	ERJ3GEYJ154	150k	
		(CAPACITORS)	
C102	ECEA1CKS470	47	S
C108	ECQE2E105KZ	1	S
C109	ECUV1H333KDV	0.033	S
C111	ECUV1H103KBV	0.01	S
C112	ECUV1H123KBV	0.012	S
C113	ECUV1C104KBV	0.1	S
C114	ECUV1C473KBV	0.047	S
C115	ECUV1H123KBV	0.012	S
C116	ECUV1H820JCV	82P	S
C118	ECUV1H104ZFB	0.1	S
C122	ECUV1H153KBV	0.015	S
C124	ECUV1H561JCV	560P	S
C125	ECEA1HKS100	10	S
C131	ECUV1H103KBV	0.01	S
C132	ECEA1CKS100	10	S
C133	ECEA1CKS470	47	S
C134	ECUV1H472KBV	0.0047	S
C136	ECEA1CKS470	47	S
C137	ECUV1H103KBV	0.01	S
C138	ECUV1H103KBV	0.01	S
C139	ECUV1C104KBV	0.1	S
C140	ECUV1C104KBV	0.1	S
C142	ECUV1H221JCV	220P	S
C159	ECUV1H103KBV	0.01	S
C171	ECEA1HKA4R7	4.7	
C172	ECUV1C393KBV	0.039	S
C173	ECUV1H102KBV	0.001	S
C175	ECUV1H681KBV	680P	S

Ref. No.	Part No.	Part Name & Description	Remarks
C176	ECUV1H681KBV	680P	S

### 12.4. OPERATION BOARD PARTS

Ref. No.	Part No.	Part Name & Description	Remarks
PCB3	FFWP3FHD331M	OPERATION BOARD ASS'Y (RTL)	
		(IC)	
IC301	MN7D032Z9J	IC	
		(DIODE)	
LED302	PQVDSL325MC	LED	S
		(LCD)	
CN302	L5DAAF00001	LIQUID CRYSTAL DISPLAY	
		(CONNECTOR)	
CN301	PQJP8G43Y	CONNECTOR, 8 PIN	S
		(SWITCHES)	
SW301	PQSH1A105Z	PUSH SWITCH	S
SW302	PQSH1A105Z	PUSH SWITCH	S
SW303	PQSH1A105Z	PUSH SWITCH	S
SW304	PQSH1A105Z	PUSH SWITCH	S
SW305	PQSH1A105Z	PUSH SWITCH	S
SW306	PQSH1A105Z	PUSH SWITCH	S
SW307	PQSH1A105Z	PUSH SWITCH	S
SW308	PQSH1A105Z	PUSH SWITCH	S
SW309	PQSH1A105Z	PUSH SWITCH	S
SW310	PQSH1A105Z	PUSH SWITCH	S
SW311	PQSH1A105Z	PUSH SWITCH	S
SW312	PQSH1A105Z	PUSH SWITCH	S
SW313	PQSH1A105Z	PUSH SWITCH	S
SW314	PQSH1A105Z	PUSH SWITCH	S
SW315	PQSH1A105Z	PUSH SWITCH	S
SW316	PQSH1A105Z	PUSH SWITCH	S
SW317	PQSH1A105Z	PUSH SWITCH	S
SW318	PQSH1A105Z	PUSH SWITCH	S
SW319	PQSH1A105Z	PUSH SWITCH	S
SW320	PQSH1A105Z	PUSH SWITCH	S
SW321	PQSH1A105Z	PUSH SWITCH	S
SW322	PQSH1A105Z	PUSH SWITCH	S
SW326	PQSH1A105Z	PUSH SWITCH	S
SW327	PQSH1A105Z	PUSH SWITCH	S
SW328	PQSH1A105Z	PUSH SWITCH	S
SW329	PQSH1A105Z	PUSH SWITCH	S
SW330	PQSH1A105Z	PUSH SWITCH	S
SW331	PQSH1A105Z	PUSH SWITCH	S
SW332	PQSH1A105Z	PUSH SWITCH	S
SW333	PQSH1A105Z	PUSH SWITCH	S
SW334	PQSH1A105Z	PUSH SWITCH	S
SW335	PQSH1A105Z	PUSH SWITCH	S
SW336	PQSH1A105Z	PUSH SWITCH	S
SW337	PQSH1A105Z	PUSH SWITCH	S
SW352	FFSH1A002Z	SWITCH, DOCUMENT TOP	
SW353	FFSH1A002Z	SWITCH, DOCUMENT SET	
		(RESISTORS)	
R302	ERJ3GEYJ271	270	
R303	ERJ3GEYJ183	18k	
R305	ERJ3GEYJ222	2.2k	
R306	ERJ3GEYJ222	2.2k	
R313	ERJ3GEYJ221	220	
R314	ERJ3GEYJ472	4.7k	
R315	ERJ3GEYJ101	100	
R316	ERJ3GEYJ472	4.7k	
R317	ERJ3GEYJ101	100	
R318	ERJ3GEYJ4R7	4.7	
R320	ERJ3GEY0R00	0	
R321	ERJ3GEY0R00	0	

Ref. No.	Part No.	Part Name & Description	Remarks
R322	ERJ3GEY0R00	0	
R323	ERJ3GEY0R00	0	
R324	ERJ3GEY0R00	0	
R325	ERJ3GEY0R00	0	
R326	ERJ3GEY0R00	0	
		(CAPACITORS)	
C302	ECUV1C104KEV	0.1	S
C303	ECEA0JKS101	100	
C304	ECUV1C104KEV	0.1	S
C306	ECUV1H101JCV	100P	S
C308	ECUV1H331JCV	330P	S
C309	ECUV1H331JCV	330P	S
C310	ECUV1C104KEV	0.1	S
C311	ECUV1C104KEV	0.1	S
C314	ECUV1C104KEV	0.1	S
C316	ECUV1H103KBV	0.01	S
C317	ECUV1H103KEV	0.01	S

### 12.5. POWER SUPPLY BOARD PARTS

Ref. No.	Part No.	Part Name & Description	Remarks
PCB4	N0AZ2GF00001	POWER SUPPLY BOARD ASS'Y (RTL)	△
		(ICs)	
IC101	PFVIFA5317P	IC	
IC201	AN1431T	IC	
IC202	AN7805F	IC	
		(TRANSISTOR)	
Q101	2SK2651	TRANSISTOR (SI)	△
		(DIODES)	
D101	PFVD1N4005	DIODE (SI)	△ S
D102	PFVD1N4005	DIODE (SI)	△ S
D103	PFVD1N4005	DIODE (SI)	△ S
D104	PFVD1N4005	DIODE (SI)	△ S
D105	PFVDEG01C	DIODE (SI)	S
D106	MA165	DIODE (SI)	
D107	MA4220	DIODE (SI)	
D108	PQVDERA1802	DIODE (SI)	S
D201	PFVDSF5LC20U	DIODE (SI)	S
D202	PFVD11DQ10	DIODE (SI)	S
		(COIL)	
L101	ELF15N005A	COIL	△
		(COMPONENT PART)	
L103	EXCELDR35	COMPONENT PART	
		(CONNECTORS)	
CN301	PQJP7G30Z	CONNECTOR, 7PIN	△
CN31	PQJP2D98Z	CONNECTOR, 2PIN	△
		(FUSE)	
F101	PQBA2C31TRLW	FUSE	△ S
		(PHOTO ELECTRIC TRANSDUCER)	
PC101	PFVIPC123	PHOTO COUPLER	△ S
		(THERMISTOR)	
TH101	PFRT57235S80	THERMISTOR	S
		(TRANSFORMER)	
T101	PFLTSTRW226V	TRANSFORMER	△ S
		(VARIABLE RESISTOR)	
VR201	EVNDJAA03B53	VARIABLE RESISTOR	

Ref. No.	Part No.	Part Name & Description	Remarks
		(VARISTOR)	
ZNR101	ERZV10DK751U	VARISTOR	△ s
		(RESISTORS)	
R101	ERDSL1J105	1M	△
R102	ERDS2TJ334	330k	
R103	ERDS2TJ334	330k	
R104	ERG2SJ304	300k	
R105	ERX2SJR22	0.22	
R106	ERG2SJ470	47	
R107	ERG2SJ304	300k	
R108	ERDS2FJ150	15	
R109	ERDS2TJ100	10	
R121	ERJ3GEYJ103	10k	
R122	ERJ3GEYJ331	330	
R124	ERJ3GEYJ181	180	
R125	ERJ3GEYJ103	10k	
R126	ERJ3GEYF562	5.6k	
R127	ERJ3GEYJ182	1.8k	
R128	PQ4R10XJ101	100	s
R136	PQ4R10XJ104	100k	s
R137	PQ4R10XJ104	100k	s
R202	ERG2SJ152	1.5k	
R203	ERDS2FJ470	47	
R221	PQ4R10XJ222	2.2k	s
R222	PQ4R10XJ222	2.2k	s
R223	PQ4R10XJ101	100	s
R224	PQ4R10XJ273	27k	s
R225	PQ4R10XJ332	3.3k	s
		(CAPACITORS)	
C101	ECQU2A224MG	0.22	△
C102	ECQU2A104MG	0.1	△
C103	PFKD2E3KH102	0.001	s
C105	PFKDE2GA222M	0.0022	△
C106	PFCEA400SX68	68	s
C108	ECKD3A102KBP	0.001	
C109	ECA1VHG470	47	
C110	PFKDD2GA222M	0.0022	s
C119	ECKD3A470KBP	47p	
C121	ECUV1H472JCV	0.0047	
C122	ECJ1VB1A224K	0.22	
C123	ECUV1H561JCV	560p	
C124	ECUV1E104KBV	0.1	s
C201	PFCEA35F471	470	s
C202	ECKN3A102KBP	0.001	
C203	PFCEA16B470	47	s
C204	PFCEA35A47M	47	s
C205	PFCEA50A1M	1	s
C206	ECKN3A102KBP	0.001	
C221	ECUV1E104KBV	0.1	
C222	ECUV1H104ZFB	0.1	

Ref. No.	Part No.	Part Name & Description	Remarks
EC2	PQZZ2K12Z	EXTENSION CORD, 2 PIN	
EC3	PQZZ7K5Z	EXTENSION CORD, 7 PIN	
EC4	PFZZ11K12Z	EXTENSION CORD, 11 PIN	
EC5	PFZZ5K13Z	EXTENSION CORD, 5 PIN	
EC6	PQZZ5K6Z	EXTENSION CORD, 5 PIN	
EC7	PQZZ3K5Z	EXTENSION CORD, 3 PIN	
EC8	PQZZ8K18Z	EXTENSION CORD, 8 PIN	
EC9	PFZZ10K1Z	EXTENSION CORD, 10 PIN	
EC10	PQZZ2K13Z	EXTENSION CORD, 2 PIN	
	KM79811245C0	BASIC FACSIMILE TECHNIQUE	

**Note:**

Tools and Extension Cords are useful for servicing.  
(They make servicing easy.)

**12.6. SENSOR BOARD PARTS**

Ref. No.	Part No.	Part Name & Description	Remarks
PCB5	PFLP1431MZ	SENSOR BOARD ASS'Y (RTL)	
		(CONNECTOR)	
CN501	PQJP3G43Z	CONNECTOR, 3 PIN	s
		(SWITCHES)	
SW501	KOMA11000030	REED SW, FILM DETECTION	
SW502	PFSHA011Z	PUSH SWITCH, COVER OPEN	

**12.7. FIXTURES AND TOOLS**

Ref. No.	Part No.	Part Name & Description	Remarks
EC1	PFZZ16K5Z	EXTENSION CORD, 16 PIN	





13.1.2. DIGITAL BOARD (PCB1): BOTTOM VIEW

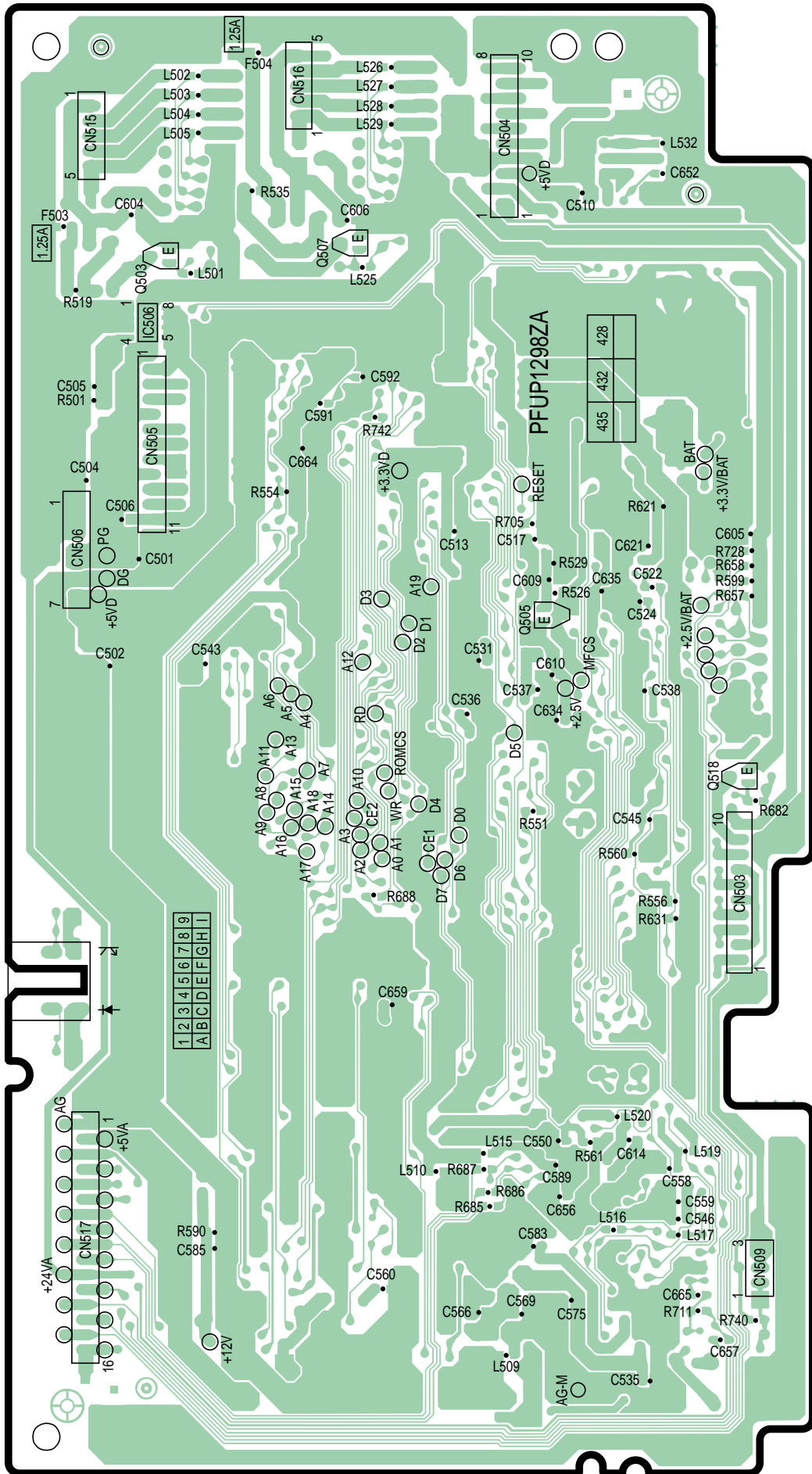

KX-FP342BX : DIGITAL BOARD(PCB1) : BOTTOM VIEW

### 13.2. ANALOG BOARD (PCB2)

#### 13.2.1. ANALOG BOARD: COMPONENT VIEW

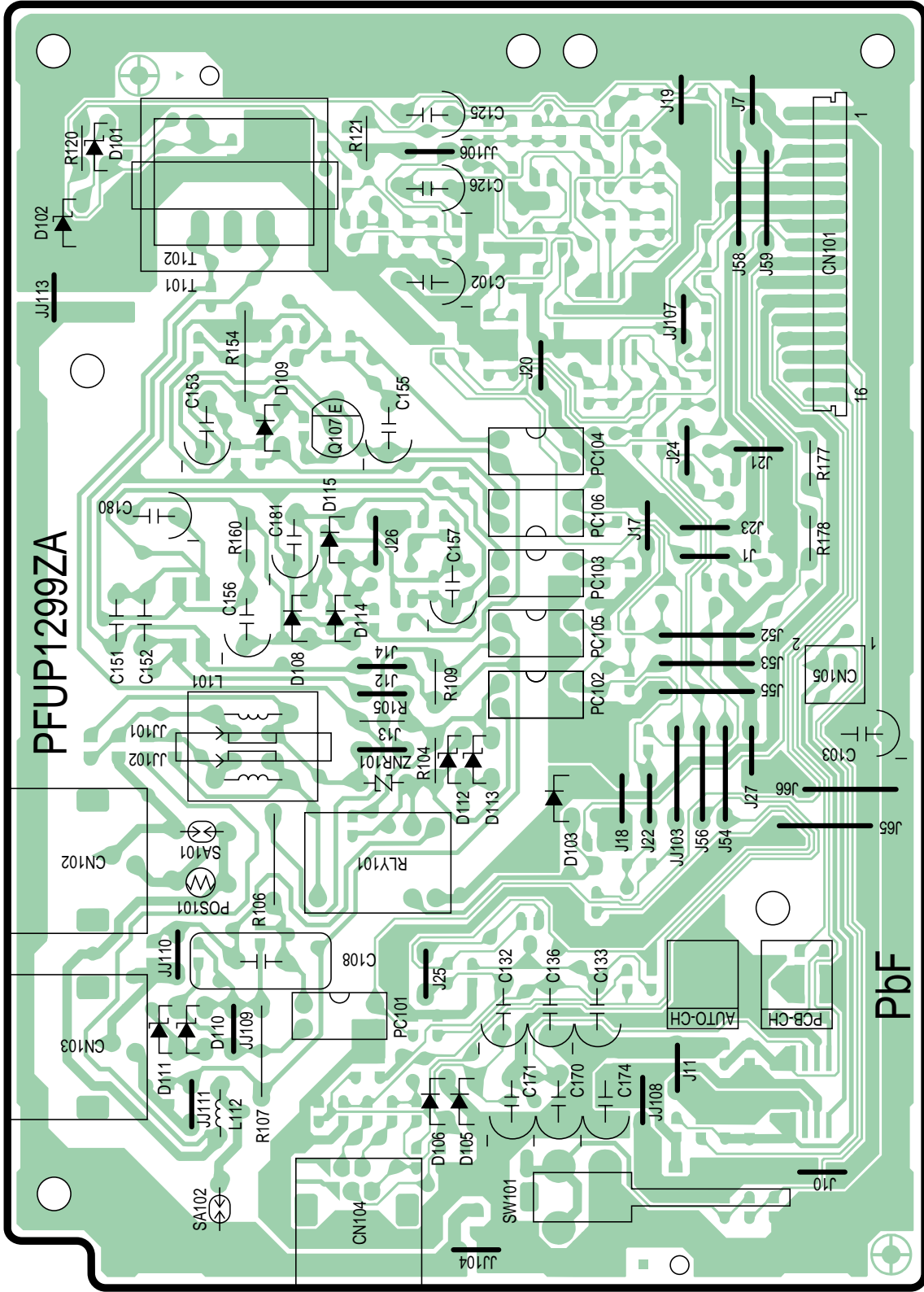

**Note:** The position of "PbF" marking sometimes may change.

KX-FP342BX : ANALOG BOARD(PCB2) : COMPONENT VIEW

13.2.2. ANALOG BOARD: BOTTOM VIEW

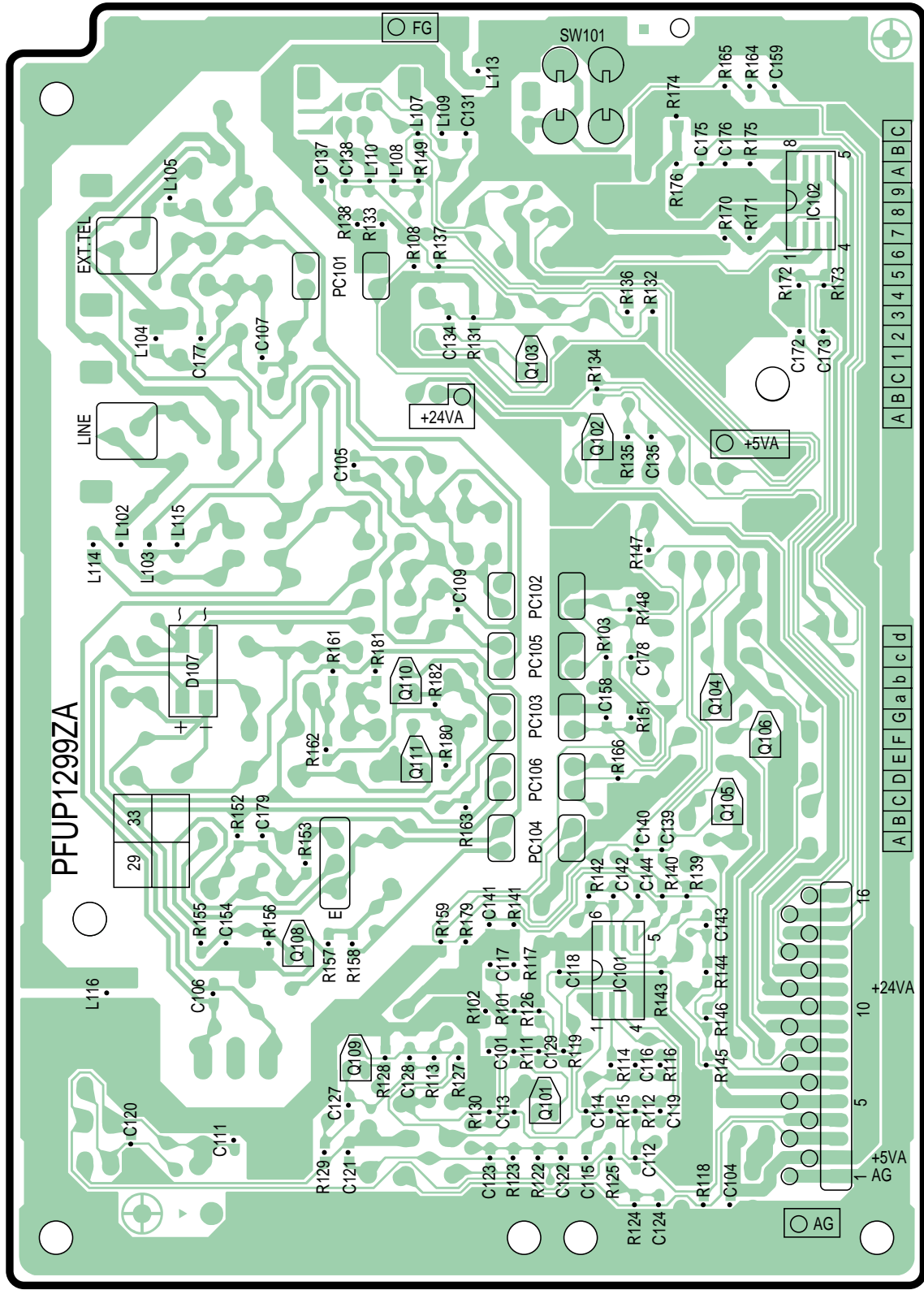

KX-FP342BX : ANALOG BOARD(PCB2) : BOTTOM VIEW

### 13.3. OPERATION BOARD (PCB3)

#### 13.3.1. OPERATION BOARD : COMPONENT VIEW

Note: The position of "PbF" marking sometimes may change.

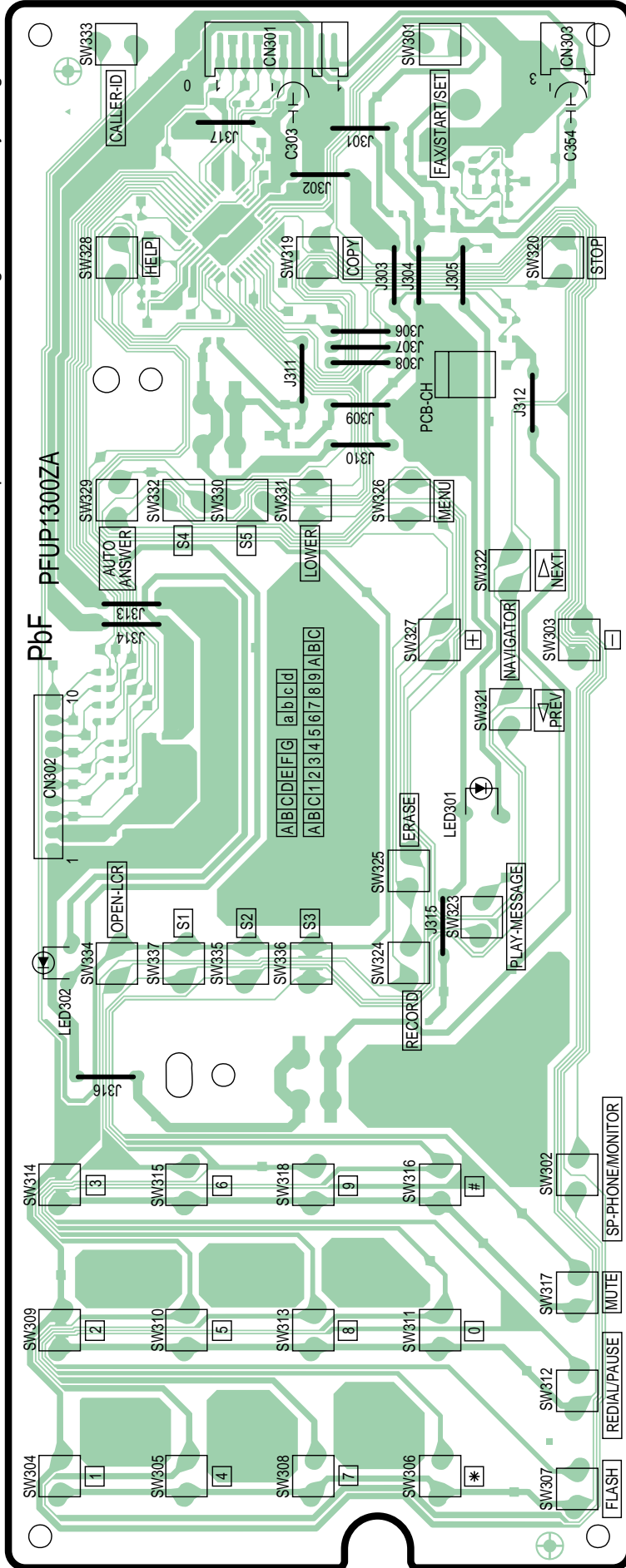

KX-FP342BX : OPERATION BOARD(PCB3) : COMPONENT VIEW

**13.3.2. OPERATION BOARD : BOTTOM VIEW**

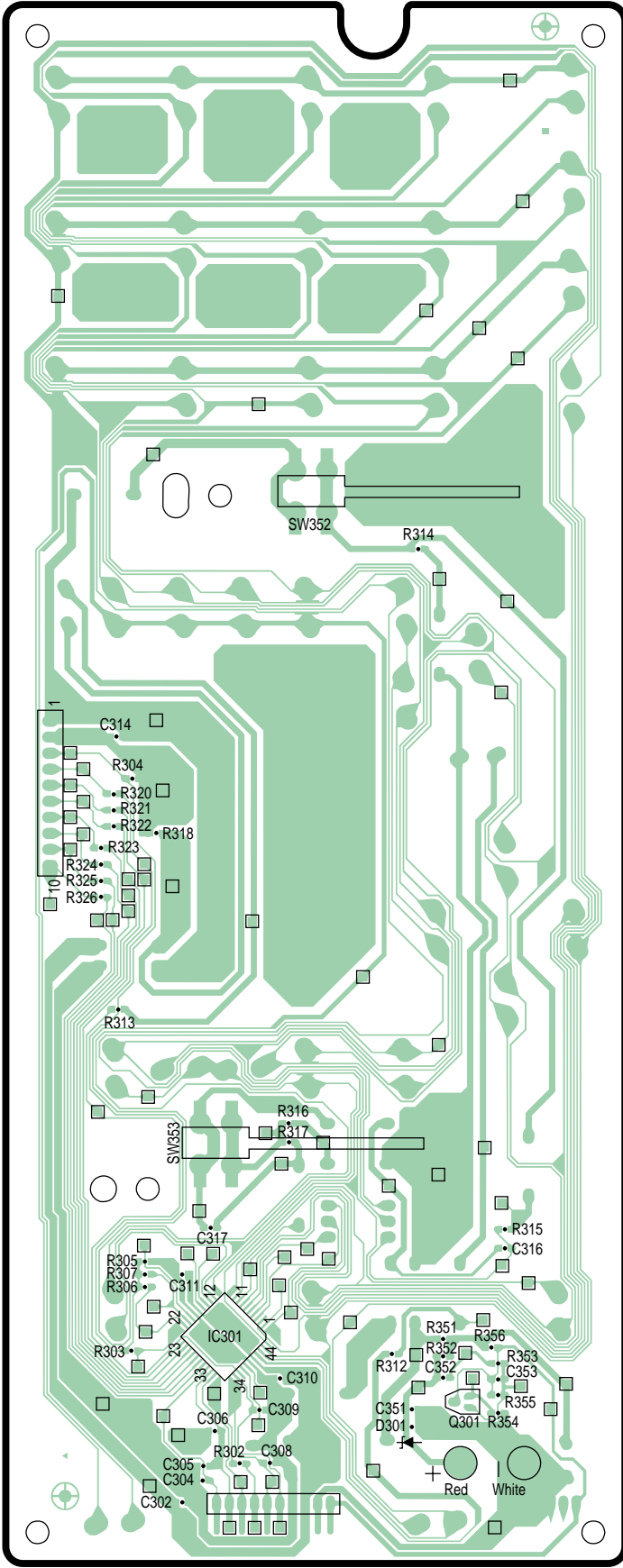

KX-FP342BX : OPERATION BOARD(PCB3) : BOTTOM VIEW

**13.4. SENSOR BOARD (PCB5)**

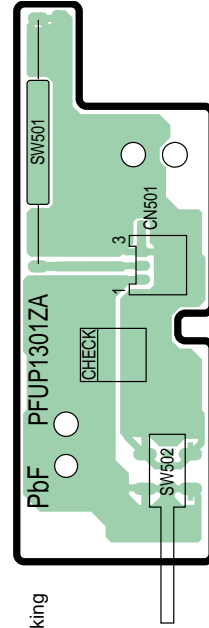

KX-FP342BX : SENSOR BOARD(PCB5)

ote: The position of "PbF" marking sometimes may change.

### 13.5. POWER SUPPLY BOARD (PCB4)

(COMPONENT VIEW)

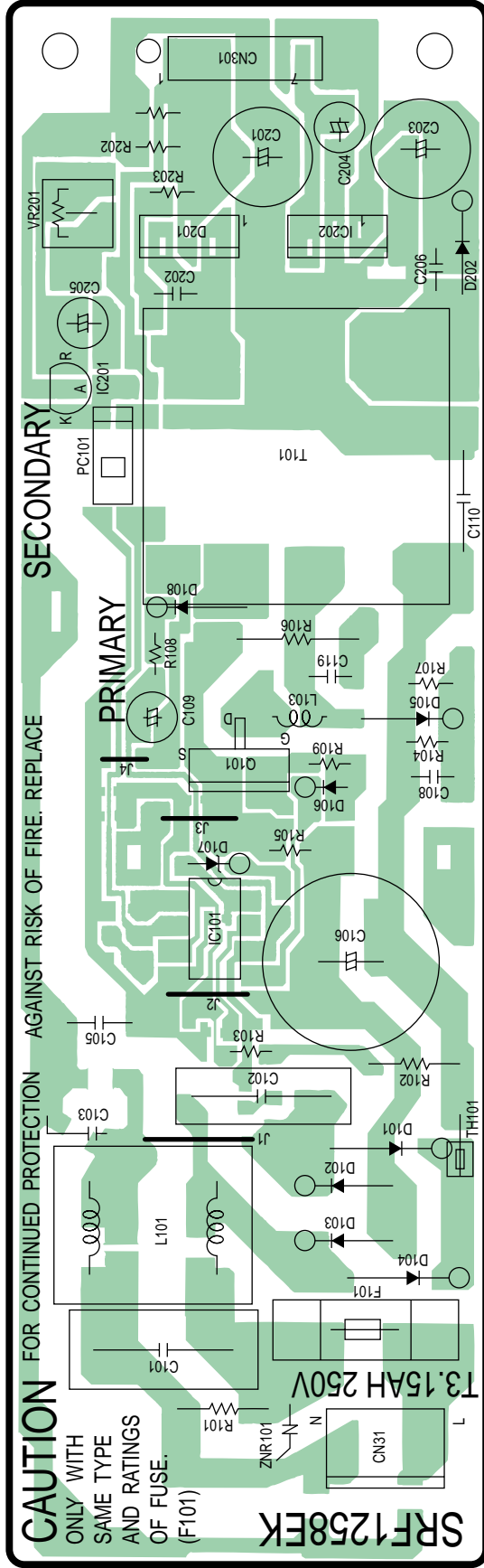

(BOTTOM VIEW)

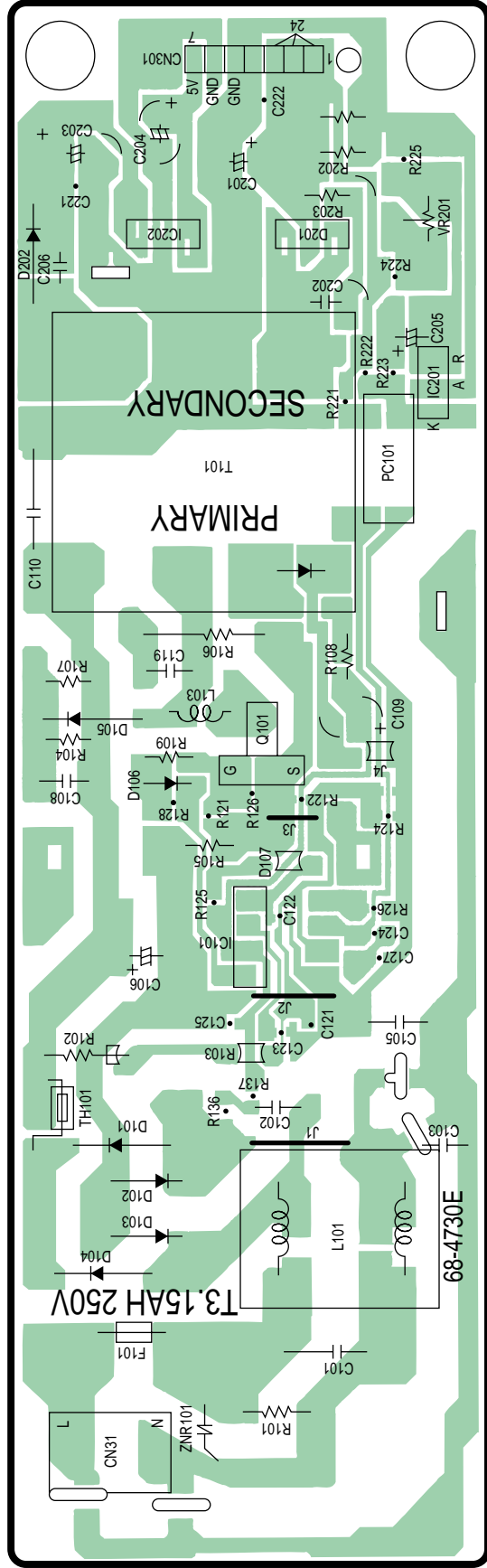

KX-FP342BX : POWER SUPPLY BOARD (PCB4)

# 14 FOR THE SCHEMATIC DIAGRAMS

## Note:

1. DC voltage measurements are taken with an oscilloscope or a tester with a ground.
2. The schematic diagrams and circuit board may be modified at any time with the development of new technology.

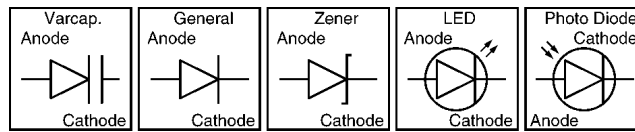

### Important safety notice

Components identified by  mark have special characteristics important for safety. When replacing any of these components, use only the manufacturer's specified parts.



# 15 SCHEMATIC DIAGRAM

## 15.1. ANALOG BOARD (PCB2)

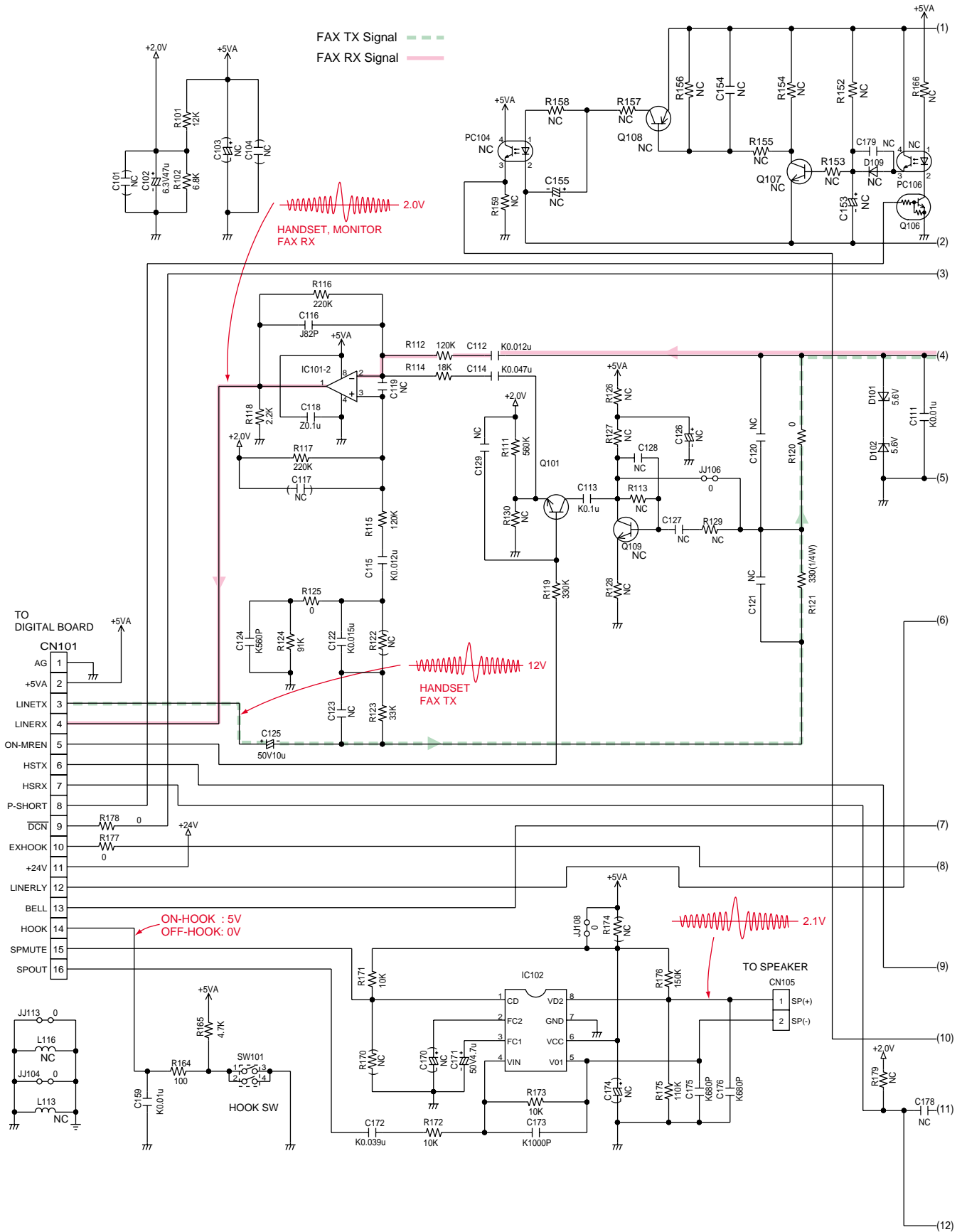

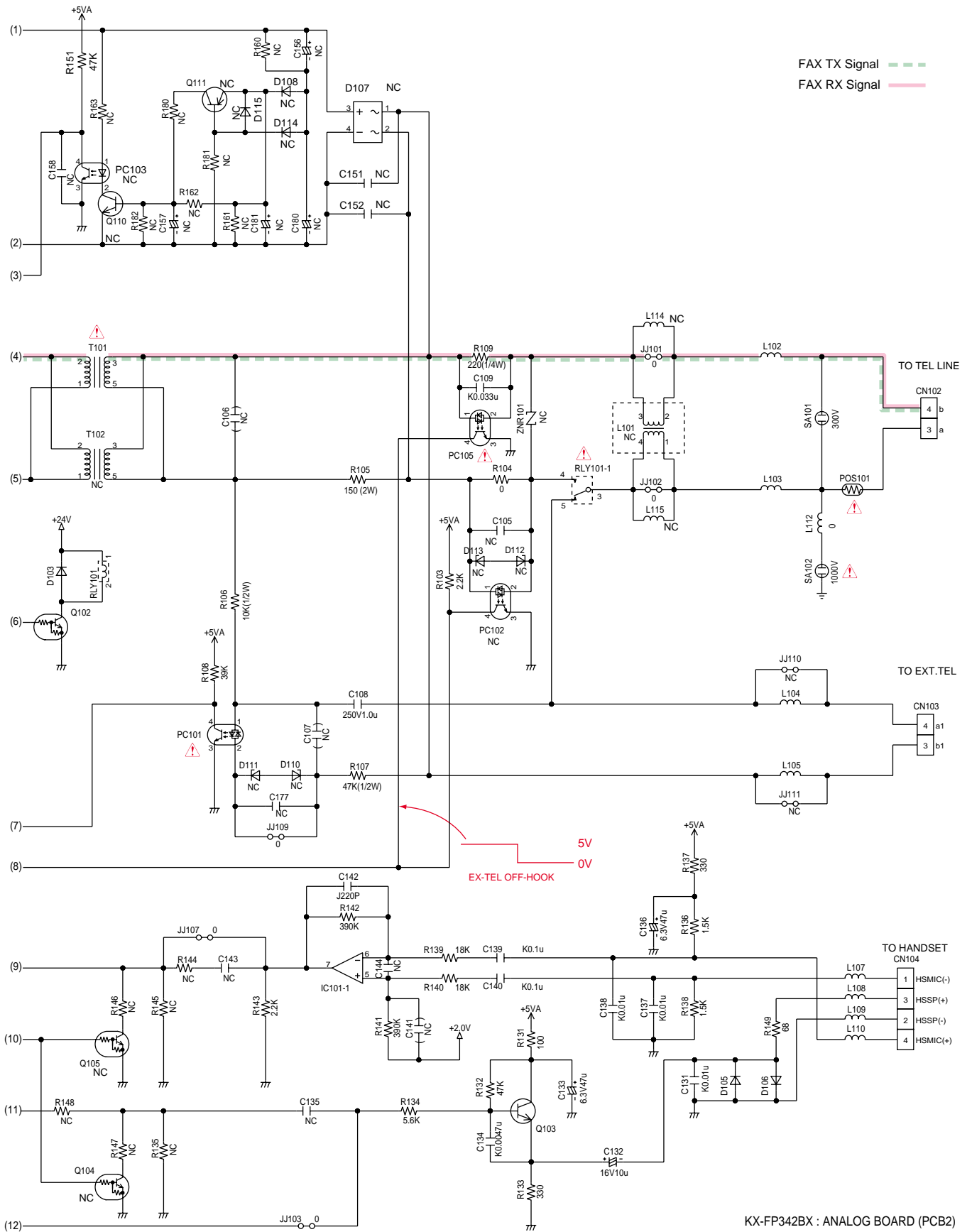

KX-FP342BX : ANALOG BOARD (PCB2)

# 15.2. DIGITAL BOARD (PCB1)

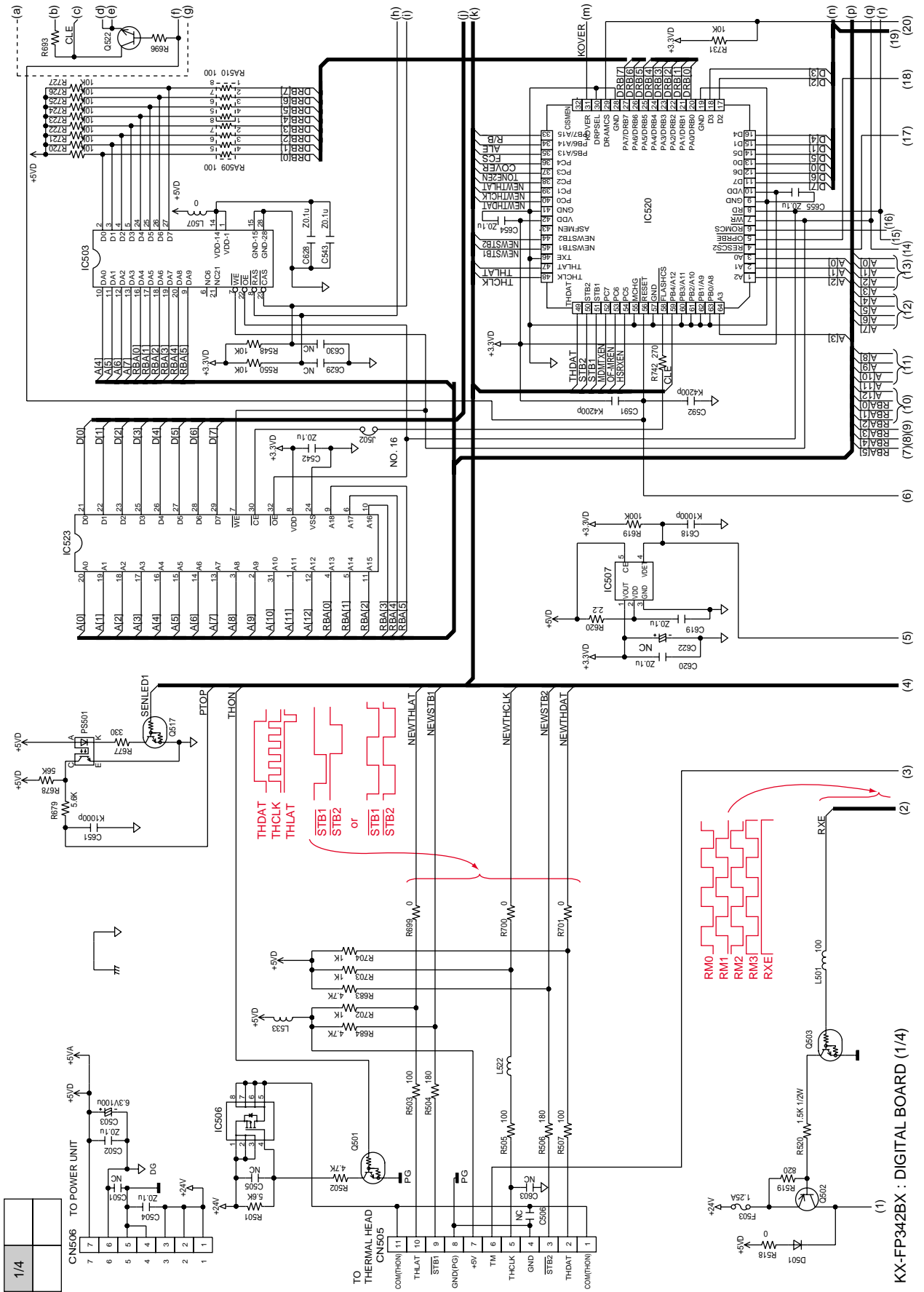

KX-FP342BX : DIGITAL BOARD (1/4)

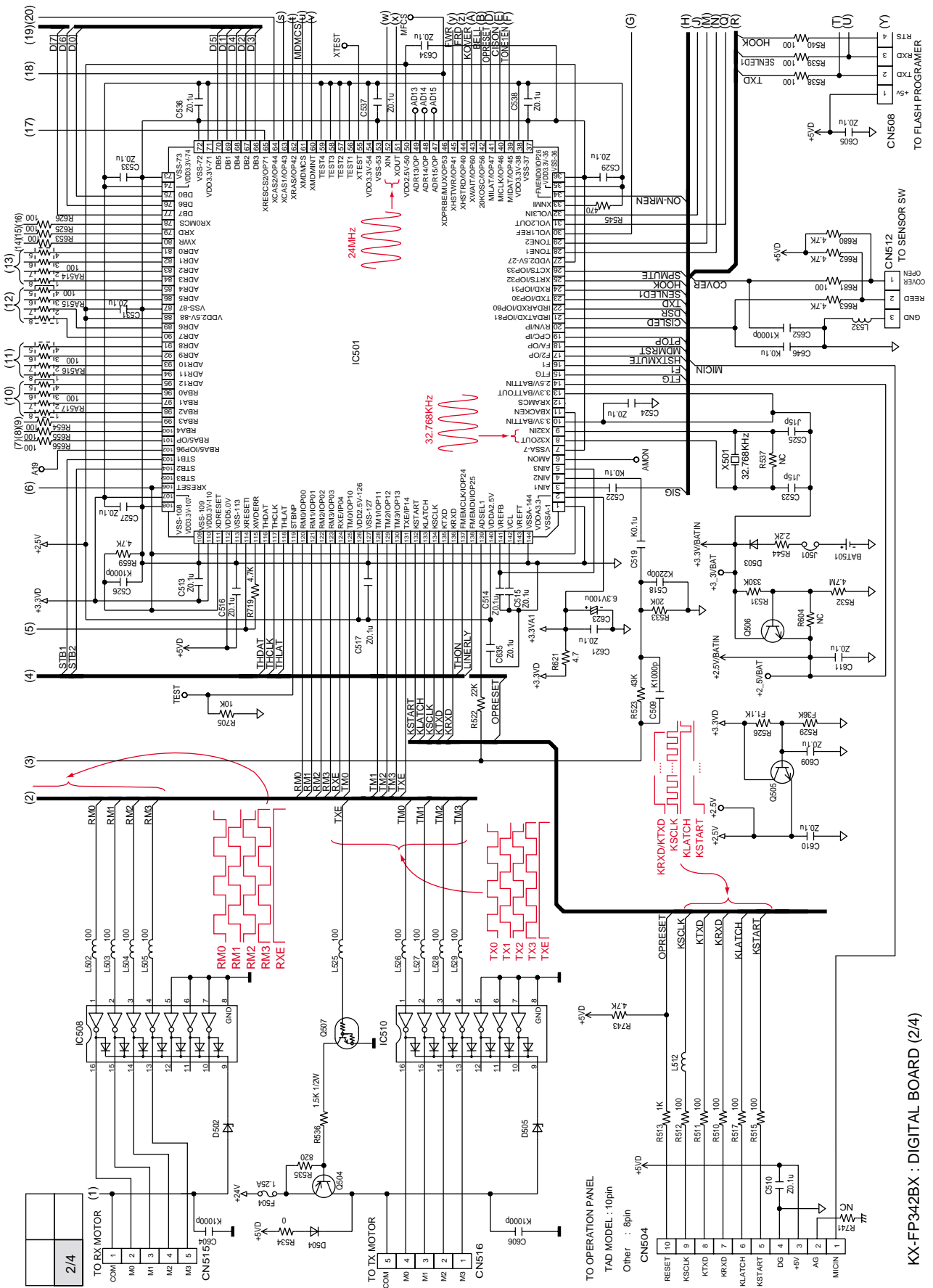

KX-FP342BX : DIGITAL BOARD (2/4)

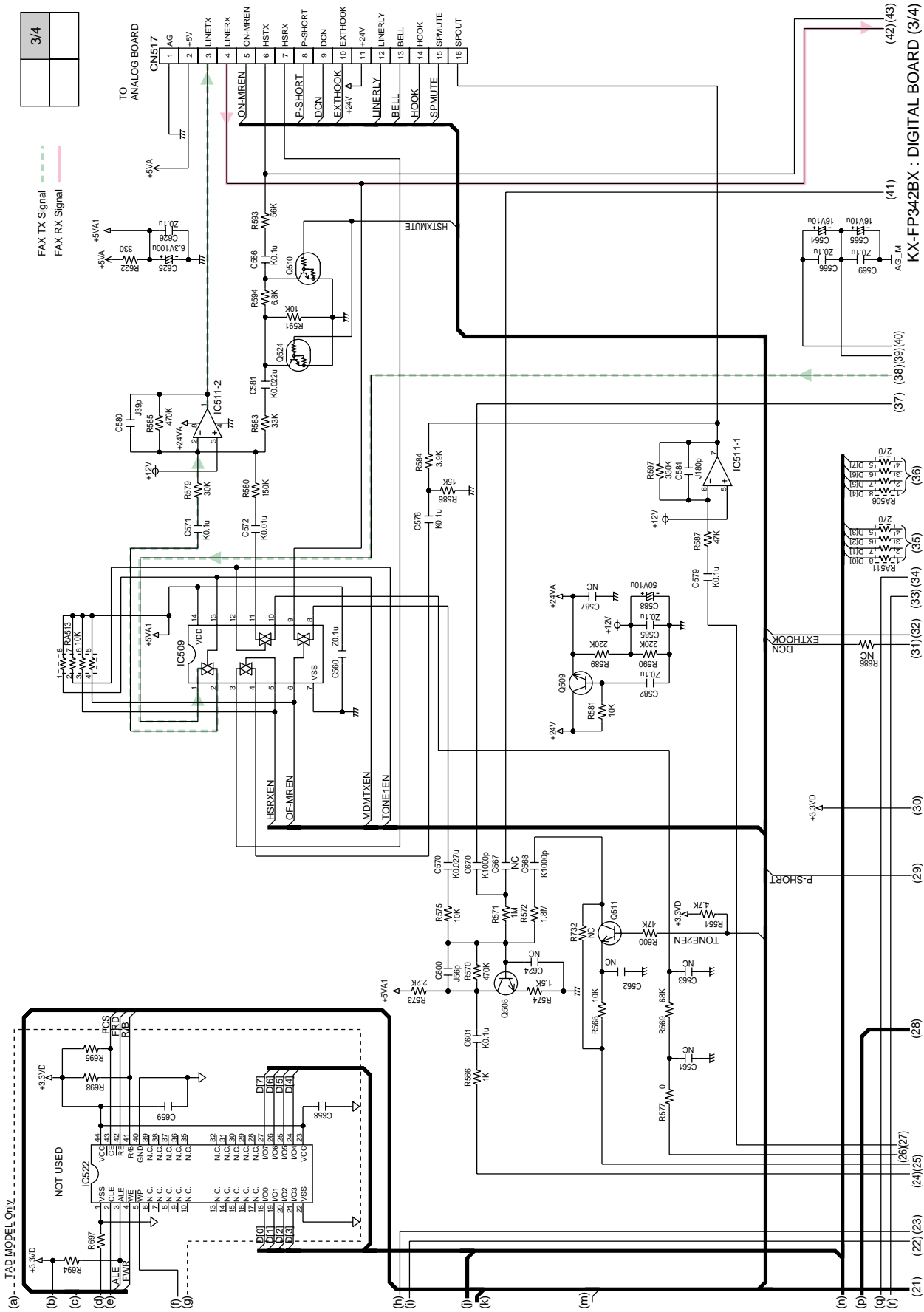



# 15.3. OPERATION BOARD (PCB3)

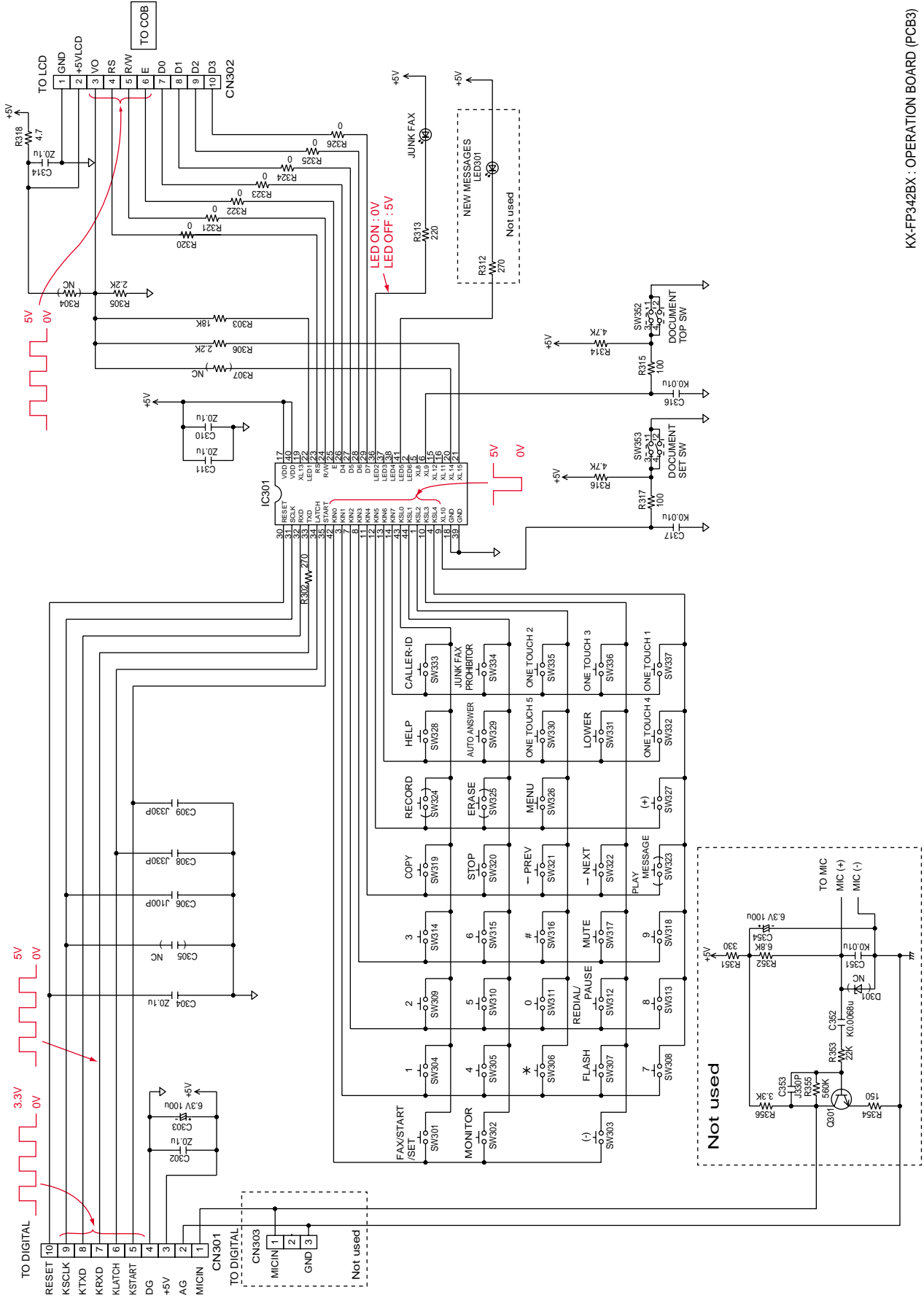

KX-FP342BX : OPERATION BOARD (PCB3)

### 15.4. POWER SUPPLY BOARD (PCB4)

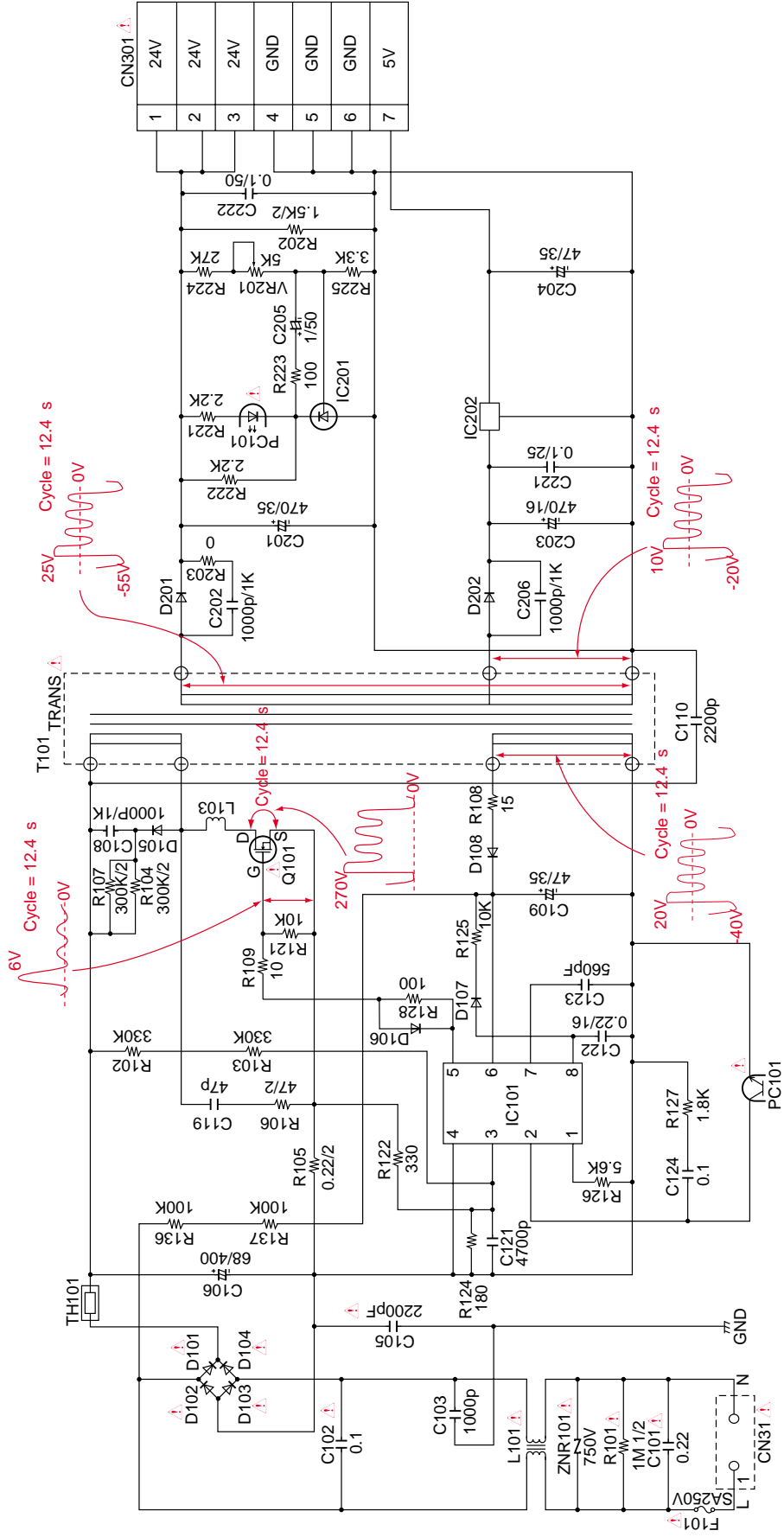

KX-FP342BX : POWER SUPPLY BOARD (PCB4)



### 15.5. SENSOR BOARD (PCB5)

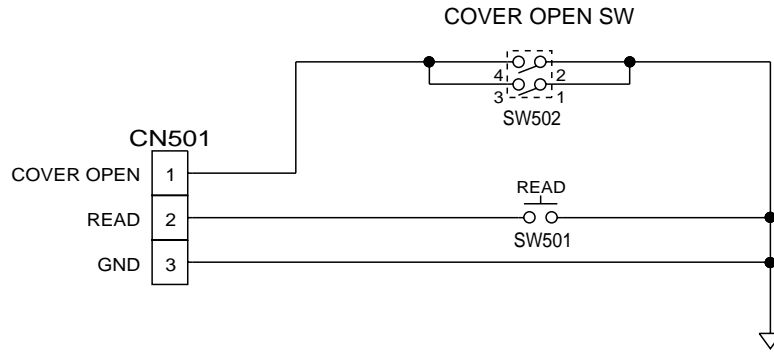

KX-FP342BX : SENSOR BOARD (PCB5)