

Service Manual

Meat Grinder

Model No. **MK-MG1300WTN**
MK-MG1300WTZ
MK-MG1300WTQ

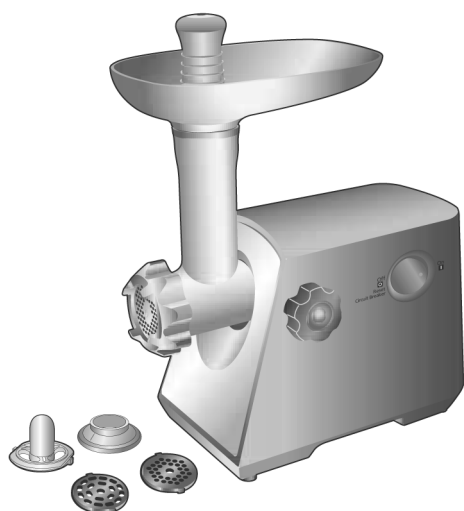

MK-MSG1300WTN (QATAR, ETC)
 MK-MSG1300WTZ (UAE, SAUDI, KUWAIT)
 MK-MSG1300WTQ (RUSSIA, UKRAINE, ETC)

⚠ WARNING

This service information is designed for experienced repair technicians only and is not designed for use by the general public. It does not contain warnings or cautions to advise non-technical individuals of potential dangers in attempting to service a product. Products powered by electricity should be serviced or repaired only by experienced professional technicians. Any attempt to service or repair the product or products dealt with in this service information by anyone else could result in serious injury or death.

IMPORTANT SAFETY NOTICE

There are special components used in this equipment which are important for safety. These parts are marked by **⚠** in the Schematic Diagrams, Circuit Board Diagrams, Exploded Views and Replacement Parts List. It is essential that these critical parts should be replaced with manufacturer's specified parts to prevent shock, fire or other hazards. Do not modify the original design without permission of manufacturer.

TABLE OF CONTENTS

	PAGE		PAGE
1 PRECAUTIONS (Strictly follow these instructions.) -----	2	6.3. SYMPTOM : A.C. motor running, but feed screw failure to turn. -----	8
2 Specifications -----	2	6.4. SYMPTOM : A.C. motor running too noisy and meat grinding too slow. -----	8
3 Schematic Diagram -----	2	6.5. SYMPTOM : A.C. motor running noise unusual. -----	8
4 Basic Wiring Diagram -----	3	6.6. SYMPTOM : Smell of burning from A.C. motor. -----	8
5 Disassembly and Assembly Instruction -----	4	7 Exploded View and Replacement Parts List -----	9
5.1. Disassembly of Motor Housing-----	4	7.1. Exploded View-----	9
5.2. Disassembly of Motor Set & Gear Box-----	5	7.2. Packing-----	10
5.3. Disassembly of Switch-----	6	7.3. Replacement Parts List-----	11
5.4. Disassembly of Switch P.C.B.-----	7		
6 Troubleshooting Guide -----	8		
6.1. SYMPTOM : A.C. motor interrupted when feeding meat (overloaded).-----	8		
6.2. SYMPTOM : Switch turned on, but A.C. motor failure to start.-----	8		

Panasonic®

© 2011 Panasonic Manufacturing Malaysia Berhad (6100-K). Unauthorized copying and distribution is a violation of law.

1 PRECAUTIONS (Strictly follow these instructions.)

CAUTION

Do not grind too hard meat. If the grinder gets stuck, do not force meat into it.

CAUTION

You may feel the feed screw vibrating during use. It is not a trouble. Do not over tighten the locking knob.

CAUTION

Keep in mind that some parts of the grinder cannot be washed in a dishwasher.

CAUTION

This meat grinder is for household use only.

2 Specifications

Destination	Qatar, ETC	Saudi, Kuwait, UAE	Russia, Ukraine, Etc
Model	MK-MG1300WTN	MK-MG1300WTZ	MK-MG1300WTQ
Power Source	AC220V~240V 50/60Hz		
Motor Power	220W - 240W		
Protective Device	Circuit Breaker AC250 V 1.6 A (4.5s - 7.0s)		
Type of Switch	THUMBLER SWITCH		
Power Cord Length	0.9 m		
Hopper Material	Aluminium		
Dimensions (WXDXH)	155mm X 255mm X 214mm		
Weight (approx.)	3.1kg		
Meat Grinding (Middle Grind Cutter)	BEEF 1000 g/min, MUTTON 650 g/min		
Cutter Type	Rough Grind 0 (Hole 7 x 16 pcs), Middle Grind 0 (Hole 5 x 30 pcs), Fine Grind 0 (Hole 3 x 78 pcs)		
Kubbe Attachments	Yes	Yes	NO

3 Schematic Diagram

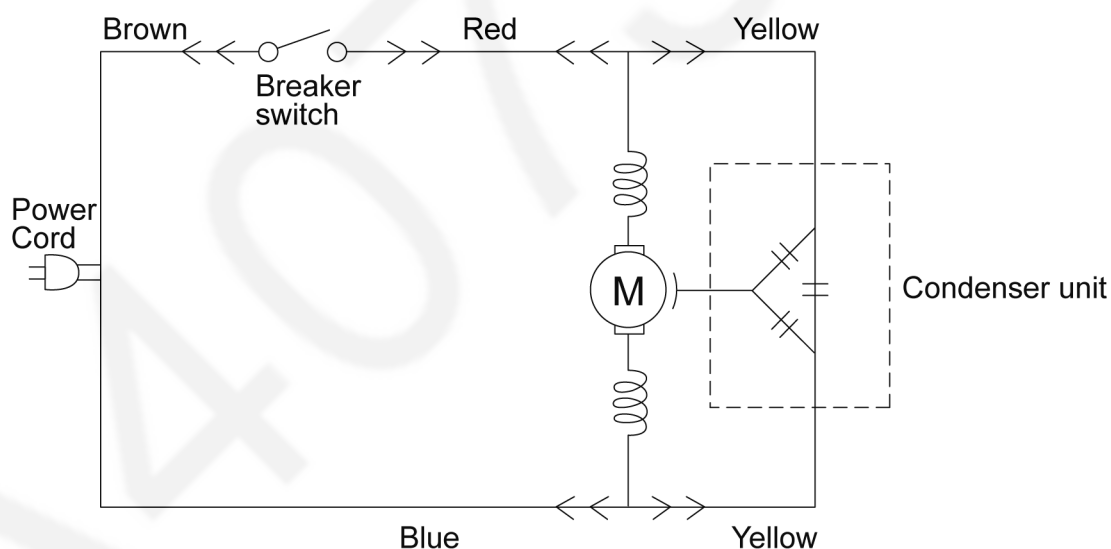

4 Basic Wiring Diagram

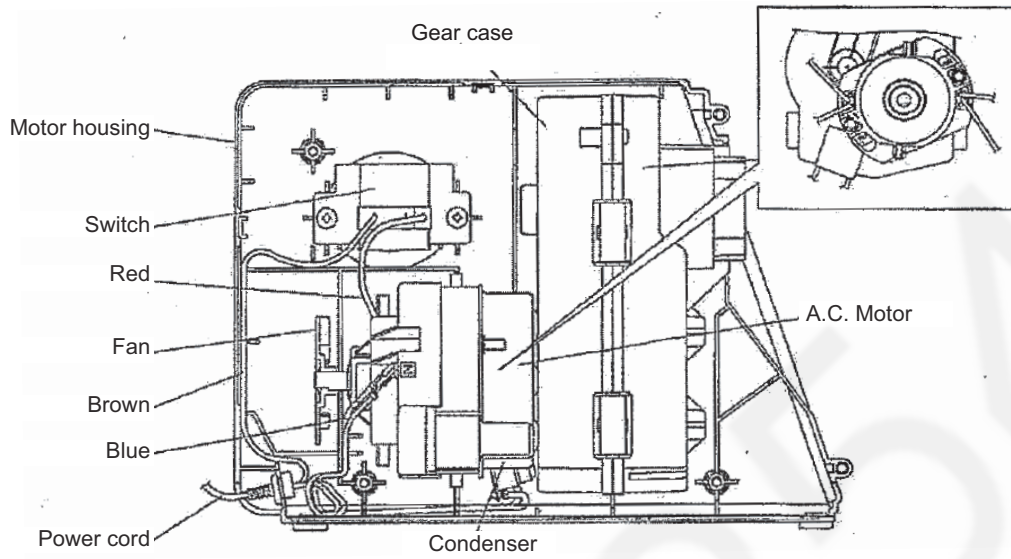

5 Disassembly and Assembly Instruction

5.1. Disassembly of Motor Housing

Step 1 Remove 4 screws.

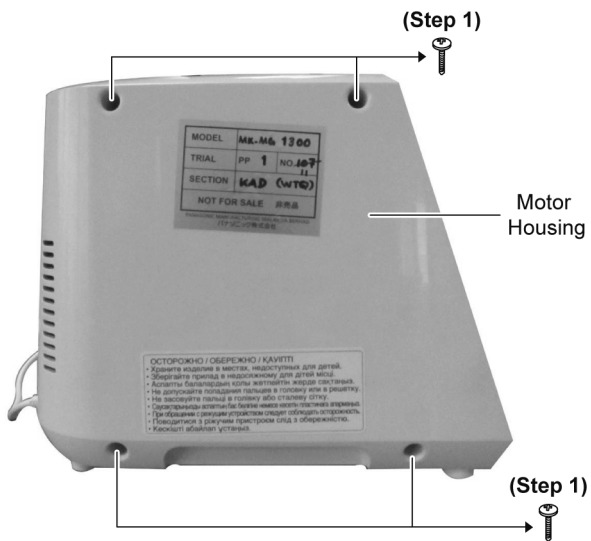

Step 2 Remove Locking Knob.

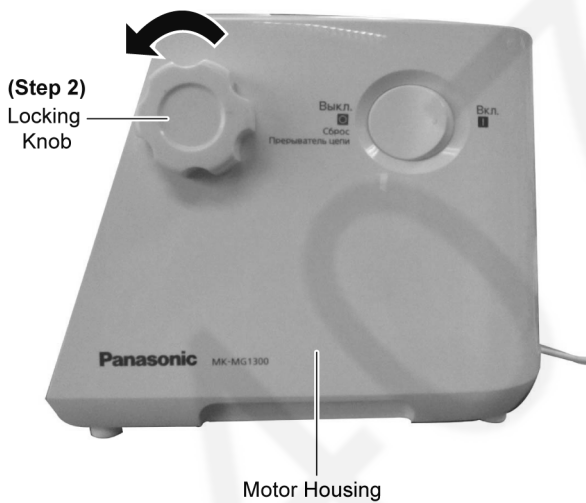

Step 3 Open Motor Housing.

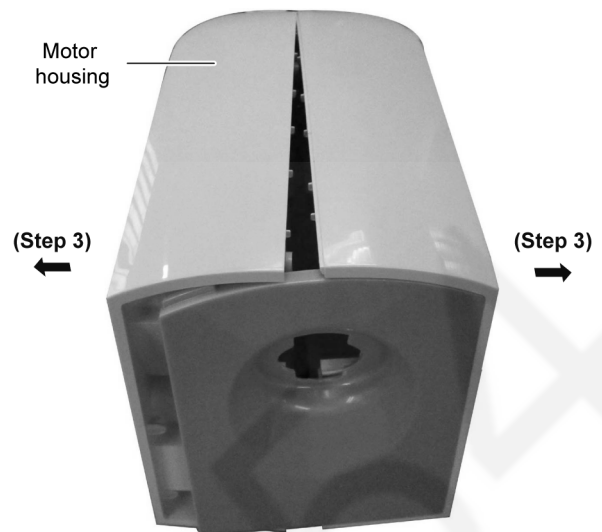

5.2. Disassembly of Motor Set & Gear Box

Step 1 Pull up Gear box.

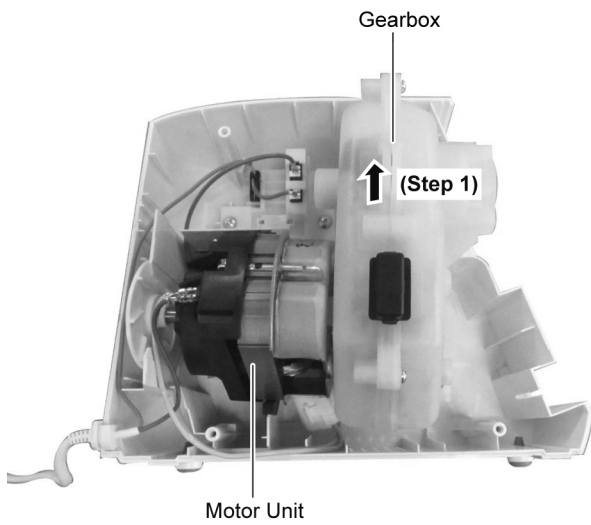

Step 2 Place the Motor Unit as shown in diagram to remove 2 screws.

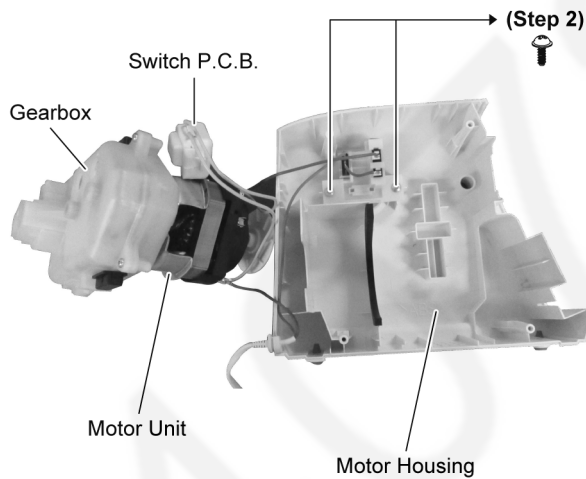

Step 3 Detach connectors from Motor Unit.

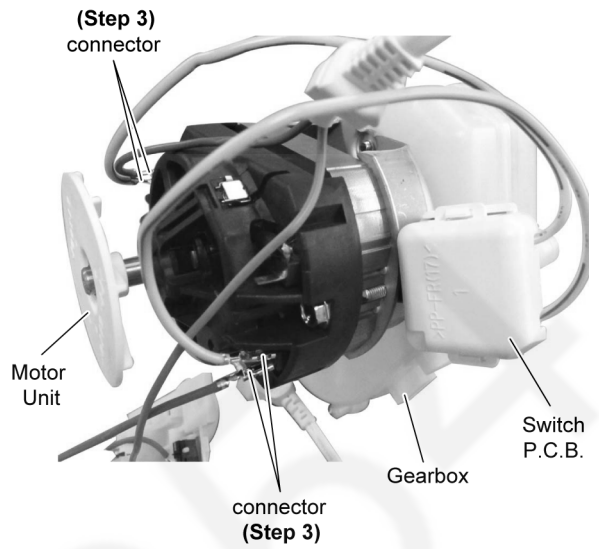

Step 4 Remove 4 screws.

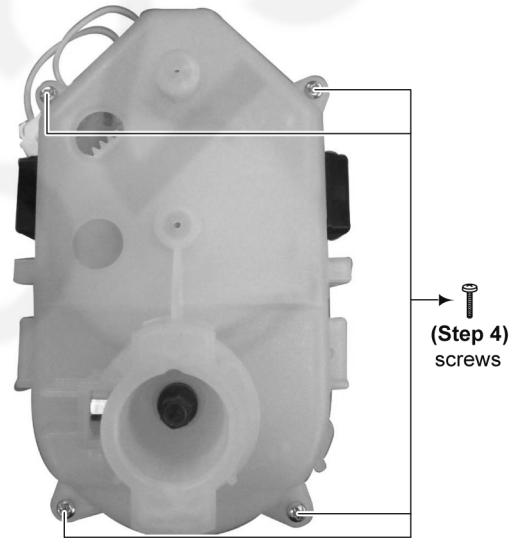

Step 5 Release 2 Rubber Holders.

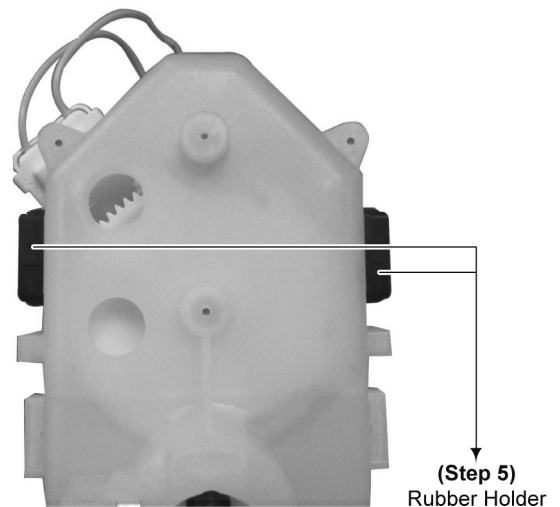

Step 6 Remove Top Gear Cover.

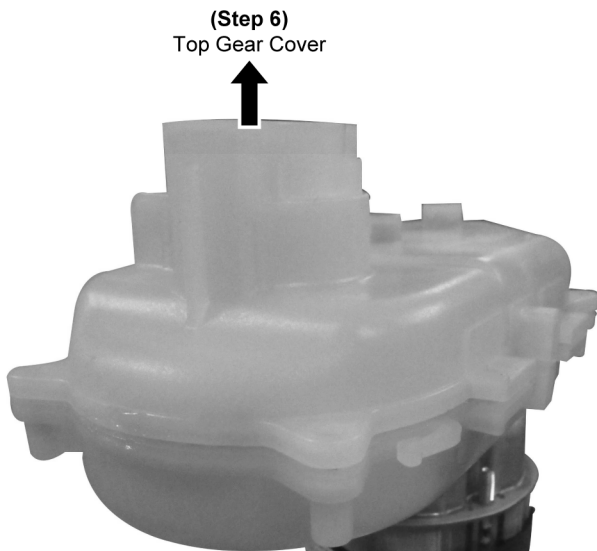

Step 7 Remove Gears

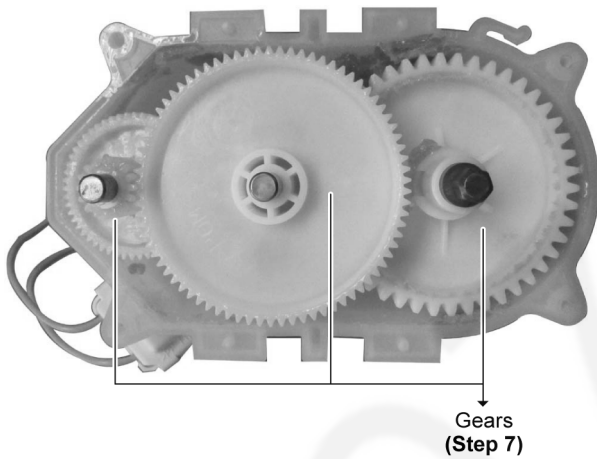

Step 8 Remove 3 screws.

Step 9 Remove Bottom Gear Cover.

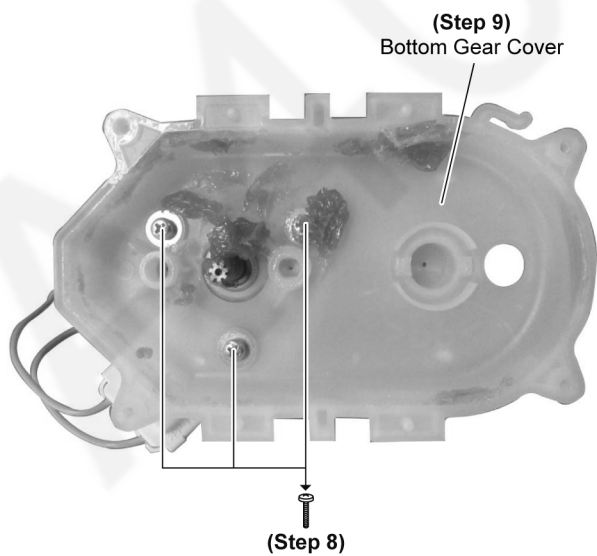

5.3. Disassembly of Switch

Step 1 Use small screwdriver to push out the catch as diagram shown.

Step 2 Remove Switch.

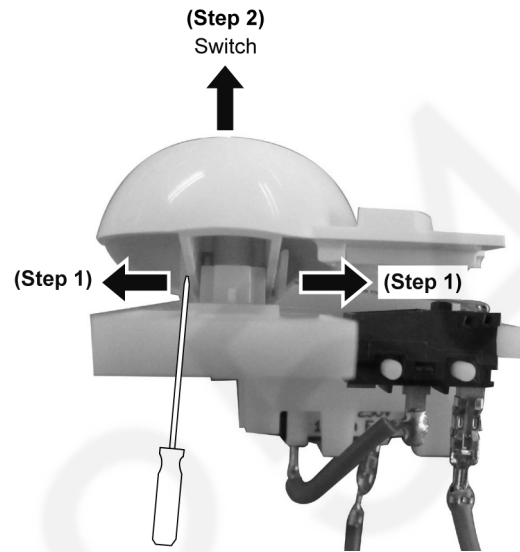

Step 3 Desolder the pin to detach wire.

Step 4 Remove Micro Switch.

Caution When removing Micro Switch, please take note of the catches.

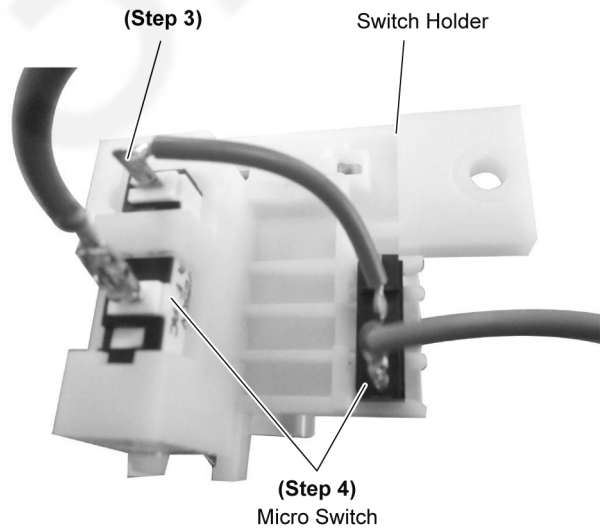

5.4. Disassembly of Switch P.C.B.

Step 1 Remove Switch Cover.

Caution When removing Micro Switch, please take note of the catches.

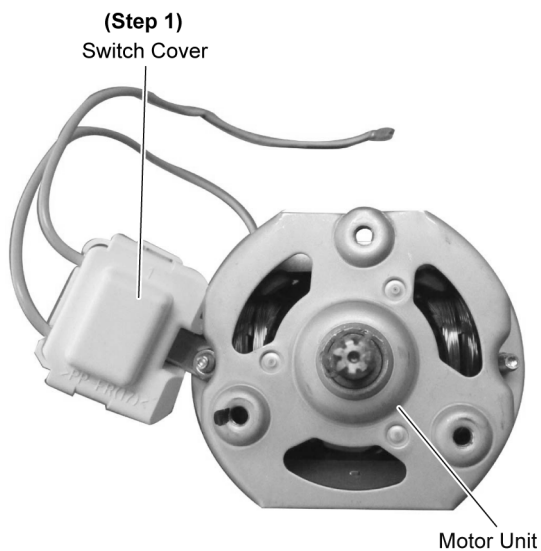

Step 2 Remove nut.

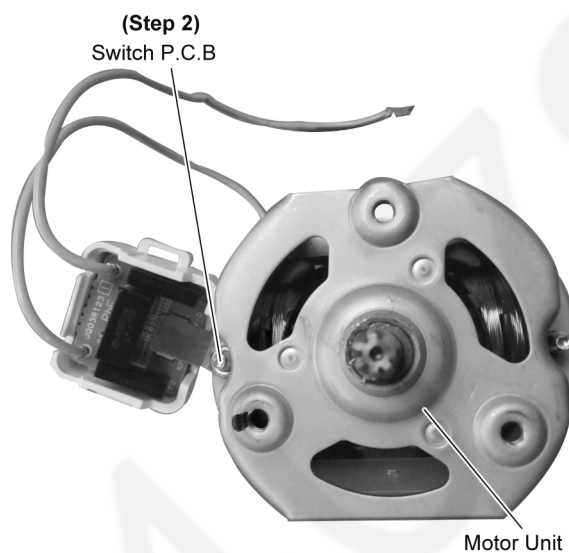

Step 3 Remove Switch P.C.B..

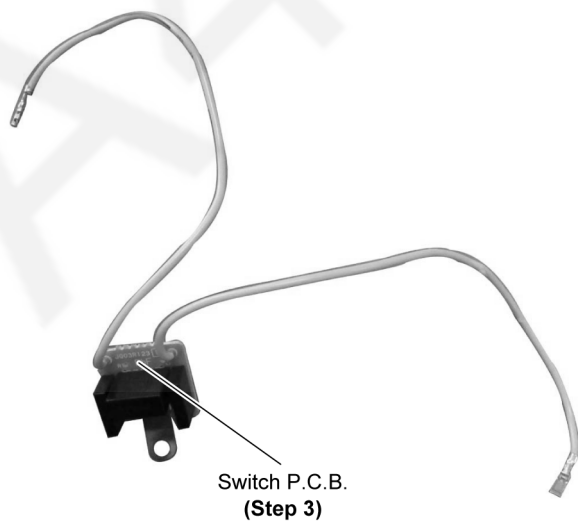

6 Troubleshooting Guide

6.1. SYMPTOM : A.C. motor interrupted when feeding meat (overloaded).

Causes	Remedy
Too hard meat being fed.	Take out the hard meat.
Too much meat being fed at once.	Reduce the meat feed rate.
Used for too long continuously.	Follow the specified operating time.
Circuit breaker activated.	Switch off and on again to reset the breaker.

6.2. SYMPTOM : Switch turned on, but A.C. motor failure to start.

Causes	Remedy
Power cord broken.	Replace the power cord.
Lead wire terminal in poor contact.	Repair or replace the lead wire terminal.
Switch in poor contact.	Replace the switch.
Carbon brush worn out.	Replace the carbon brush.
A.C. motor coil broken.	Replace the A.C. motor.

6.3. SYMPTOM : A.C. motor running, but feed screw failure to turn.

Causes	Remedy
Gears worn out.	Replace the gears.
Gears damaged.	Replace the gears.
Feed screw worn out.	Replace the feed screw.
Feed screw damaged.	Replace the feed screw.

6.4. SYMPTOM : A.C. motor running too noisy and meat grinding too slow.

Causes	Remedy
Carbon brush worn out.	Replace the carbon brush.
Gears worn out or damaged.	Replace the gears.
Cutting blade or cutting plate worn out.	Replace the cutting blade or cutting plate.

6.5. SYMPTOM : A.C. motor running noise unusual.

Causes	Remedy
Foreign matter caught in gears.	Take out the foreign matter.
Gears worn out or damaged.	Replace the gears.

6.6. SYMPTOM : Smell of burning from A.C. motor.

Causes	Remedy
A.C. motor insulation degraded.	Replace the A.C. motor.

7 Exploded View and Replacement Parts List

7.1. Exploded View

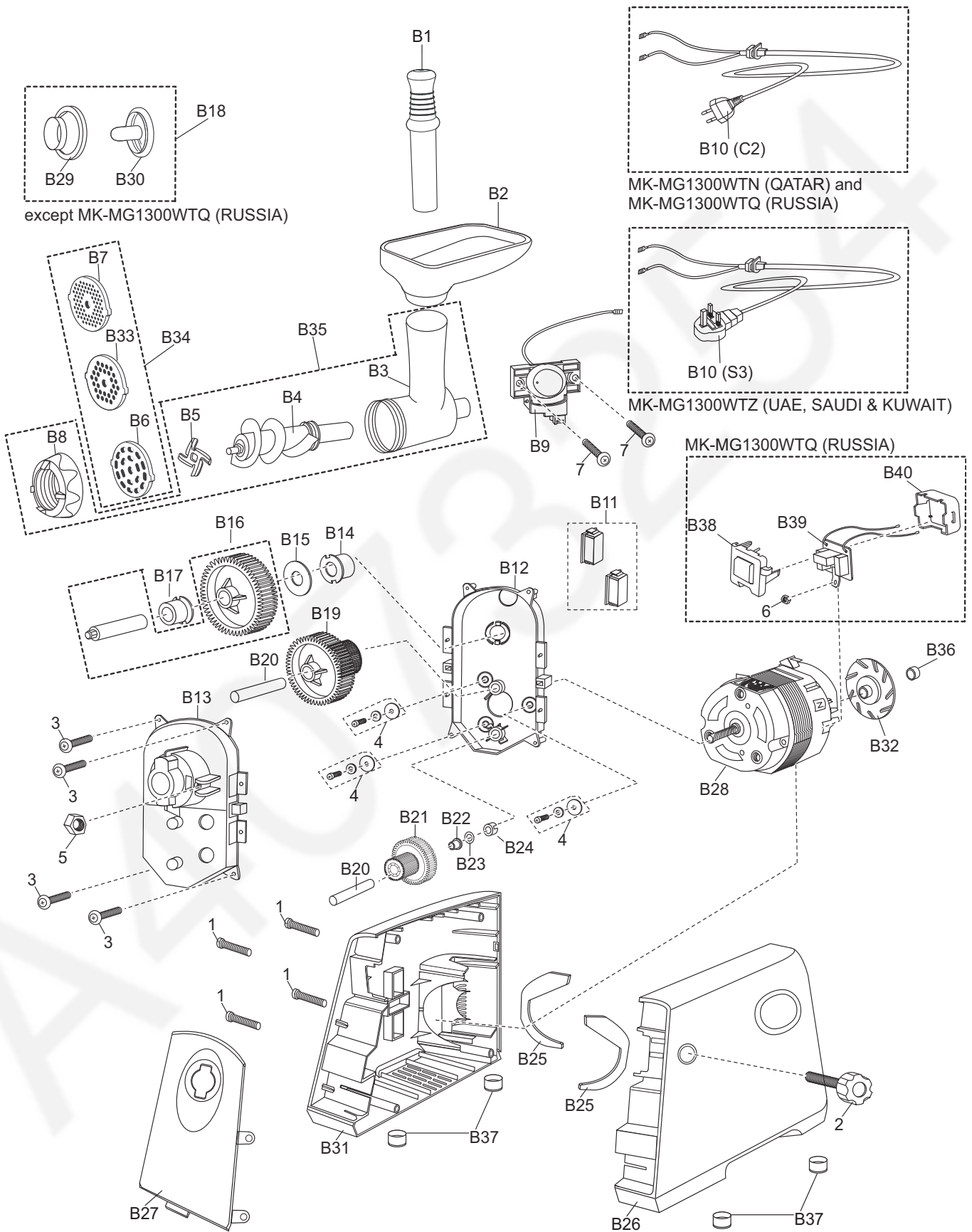

7.2. Packing

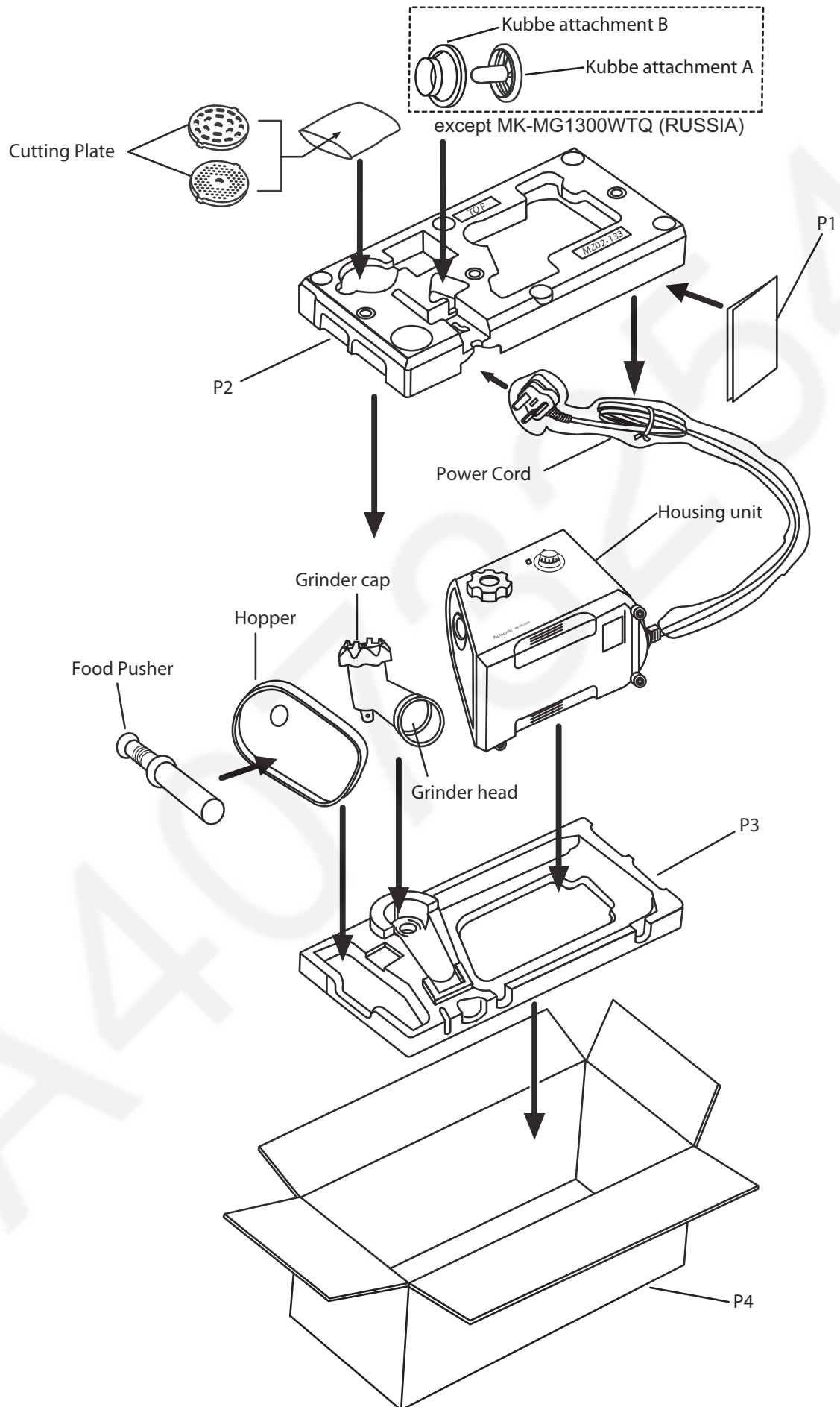

7.3. Replacement Parts List

7.3.1. MK-MG1300WTN (QATAR, ETC)

Safety	Ref. No.	Part No.	Part Name & Description	Qty	Remarks
	B1	AME04-1072W0	PLUNGER	1	
	B2	AME03-133-KS	HOPPER	1	ALUMINIUM
	B3	AME01-121	SCREW BODY	1	
	B4	AME97-121	SCREW (U)	1	
	B5	AM12C18000	ROTATING CUTTER	1	
	B6	AM08C18100	CUTTER A	1	
	B7	AM10C18100	CUTTER C	1	
	B8	AME02-121	BODY COVER	1	
	B9	AMN98-126-W4	COMPLETE SWITCH ASS'Y	1	
△	B10	AMP96-126	CORD UNIT	1	C2 PLUG
	B11	AMB34-133	GEAR CUSHION RUBBER	2	
	B12	AMB26-1073	GEAR CASE	1	
	B13	AMB89-1073	GEAR CASE COVER LID UNIT	1	
	B14	AM04B18100	OILLESS BEARING A	1	
	B15	AM18B18000	WASHER B	1	
	B16	AM95B27300	C GEAR UNIT	1	
	B17	AM05B18100	OILLESS BEARING B	1	
	B18	AM24Q27300	KUBBE COMPLETE	1	
	B19	AM09B27300	B GEAR	1	
	B20	AM26B18300	A GEAR SHAFT	2	
	B21	AM96B18300	A GEAR UNIT	1	
	B22	AM06B18000	OILLESS BEARING C	1	
	B23	AM56B18100	WASHER C	1	
	B24	AMB38-126	GEAR CASE CAP	3	
	B25	AMB35-133	MOTOR CUSHION RUBBER	2	
	B26	AMB91Y132-W4	BODY LEFT UNIT	1	
	B27	AMB21-126-H3	FRONT PLATE	1	
△	B28	ATXM121A	MOTOR	1	
	B29	AM24C27300	KUBBE COVER	1	
	B30	AM96C27300	KUBBE UNIT	1	
	B31	AMB19-126-W4	BODY RIGHT	1	
	B32	AMM31-121	FAN	1	
	B33	AME05-121	CUTTER F	1	
	B34	AMA20-121	FIXED CUTTER COMPLETE	1	
	B35	AMA32-121	COMPLETE SCREW BODY	1	
	B36	ASPN-8	PUSH NUT	1	
	B37	AJ33A53000	FOOT	4	
	1	XTN4+20BFJ	SCREW	4	
	2	AMB85-133-W4	FIX KNOB UNIT	1	
	3	XTN4+20BFJ	PLUS TAPPING SCREW	4	
	4	XYN4+20BFJ	SCREW WITH SPRING AND ROUND WASHER	3	
	5	XNG8BFJ	HEXAGONAL NUT	1	
	6	XNG5EFJ	HEXAGONAL NUT	1	
	7	XTT4+16BFJ	THRUST TAPPING SCREW	2	
			PACKING LIST		
△	P1	AMZ50Y132	OPERATING INSTRUCTION	1	
	P2	AMZ02-126	TOP CUSHION	1	
	P3	AMZ03-126	BOTTOM CUSHION	1	
	P4	AMZ01Y132	CARTON BOX	1	

7.3.2. MK-MG1300WTZ (SAUDI, KUWAIT, UAE)

Safety	Ref. No.	Part No.	Part Name & Description	Qty	Remarks
	B1	AME04-1072W0	PLUNGER	1	
	B2	AME03-133-KS	HOPPER	1	ALUMINIUM
	B3	AME01-121	SCREW BODY	1	
	B4	AME97-121	SCREW (U)	1	
	B5	AM12C18000	ROTATING CUTTER	1	
	B6	AM08C18100	CUTTER A	1	
	B7	AM10C18100	CUTTER C	1	
	B8	AME02-121	BODY COVER	1	
	B9	AMN98-126-W4	COMPLETE SWITCH ASS'Y	1	
△	B10	AMP91J126	CORD UNIT	1	S3 PULG WITH CAP
	B11	AMB34-133	GEAR CUSHION RUBBER	2	
	B12	AMB26-1073	GEAR CASE	1	
	B13	AMB89-1073	GEAR CASE COVER LID UNIT	1	
	B14	AM04B18100	OILLESS BEARING A	1	
	B15	AM18B18000	WASHER B	1	
	B16	AM95B27300	C GEAR UNIT	1	
	B17	AM05B18100	OILLESS BEARING B	1	
	B18	AM24Q27300	KUBBE COMPLETE	1	
	B19	AM09B27300	B GEAR	1	
	B20	AM26B18300	A GEAR SHAFT	2	
	B21	AM96B18300	A GEAR UNIT	1	
	B22	AM06B18000	OILLESS BEARING C	1	
	B23	AM56B18100	WASHER C	1	
	B24	AMB38-126	GEAR CASE CAP	3	
	B25	AMB35-133	MOTOR CUSHION RUBBER	2	
	B26	AMB91Y132-W4	BODY LEFT UNIT	1	
	B27	AMB21-126-H3	FRONT PLATE	1	
△	B28	ATXM121A	MOTOR	1	
	B29	AM24C27300	KUBBE COVER	1	
	B30	AM96C27300	KUBBE UNIT	1	
	B31	AMB19-126-W4	BODY RIGHT	1	
	B32	AMM31-121	FAN	1	
	B33	AME05-121	CUTTER F	1	
	B34	AMA20-121	FIXED CUTTER COMPLETE	1	
	B35	AMA32-121	COMPLETE SCREW BODY	1	
	B36	ASPN-8	PUSH NUT	1	
	B37	AJ33A53000	FOOT	4	
	1	XTN4+20BFJ	SCREW	4	
	2	AMB85-133-W4	FIX KNOB UNIT	1	
	3	XTN4+20BFJ	PLUS TAPPING SCREW	4	
	4	XYN4+20BFJ	SCREW WITH SPRING AND ROUND WASHER	3	
	5	XNG8BFJ	HEXAGONAL NUT	1	
	6	XNG5EFJ	HEXAGONAL NUT	1	
	7	XTT4+16BFJ	THRUST TAPPING SCREW	2	
			PACKING LIST		
△	P1	AMZ50Y132	OPERATING INSTRUCTION	1	
	P2	AMZ02-126	TOP CUSHION	1	
	P3	AMZ03-126	BOTTOM CUSHION	1	
	P4	AMZ01Y132	CARTON BOX	1	

7.3.3. MK-MG1300WTQ (RUSSIA, UKRAINE, ETC)

Safety	Ref. No.	Part No.	Part Name & Description	Qty	Remarks
	B1	AME04-1072W0	PLUNGER	1	
	B2	AME03-133-KS	HOPPER	1	ALUMINIUM
	B3	AME01-121	SCREW BODY	1	
	B4	AME97-121	SCREW (U)	1	
	B5	AM12C18000	ROTATING CUTTER	1	
	B6	AM08C18100	CUTTER A	1	
	B7	AM10C18100	CUTTER C	1	
	B8	AME02-121	BODY COVER	1	
	B9	AMN98-126-W4	COMPLETE SWITCH ASS'Y	1	
△	B10	AMP96-126	CORD UNIT	1	C2 PULG
	B11	AMB34-133	GEAR CUSHION RUBBER	2	
	B12	AMB26-1073	GEAR CASE	1	
	B13	AMB89-1073	GEAR CASE COVER LID UNIT	1	
	B14	AM04B18100	OILLESS BEARING A	1	
	B15	AM18B18000	WASHER B	1	
	B16	AM95B27300	C GEAR UNIT	1	
	B17	AM05B18100	OILLESS BEARING B	1	
	B19	AM09B27300	B GEAR	1	
	B20	AM26B18300	A GEAR SHAFT	2	
	B21	AM96B18300	A GEAR UNIT	1	
	B22	AM06B18000	OILLESS BEARING C	1	
	B23	AM56B18100	WASHER C	1	
	B24	AMB38-126	GEAR CASE CAP	3	
	B25	AMB35-133	MOTOR CUSHION RUBBER	2	
	B26	AMB91K132-W4	BODY LEFT UNIT	1	
	B27	AMB21-126-H3	FRONT PLATE	1	
△	B28	ATXM121AR	MOTOR	1	
	B31	AMB19-126-W4	BODY RIGHT	1	
	B32	AMM31-121	FAN	1	
	B33	AME05-121	CUTTER F	1	
	B34	AMA20-121	FIXED CUTTER COMPLETE	1	
	B35	AMA32-121	COMPLETE SCREW BODY	1	
	B36	ASPN-8	PUSH NUT	1	
	B37	AJ33A53000	FOOT	4	
	B38	AME20-1211	CAPACITOR BASE COVER A	1	
	B39	AME21-1211	CAPACITOR BASE COVER B	1	
	B40	AMQ98J113	CAPACITOR BASE UNIT	1	
	1	XTN4+20BFJ	SCREW	4	
	2	AMB85-133W4	FIX KNOB UNIT	1	
	3	XTN4+20BFJ	PLUS TAPPING SCREW	4	
	4	XYN4+20BFJ	SCREW WITH SPRING AND ROUND WASHER	3	
	5	XNG8BFJ	HEXAGONAL NUT	1	
	6	XNG5EFJ	HEXAGONAL NUT	1	
			PACKING LIST		
△	P1	AMZ99K132	OPERATING INSTRUCTION ASS'Y	1	
△	P1	AMZ50K132	OPERATING INSTRUCTION	1	
△	P1	AMZ52K132	OPERATING INSTRUCTION B	1	
	P2	AMZ02-126	TOP CUSHION	1	
	P3	AMZ03-126	BOTTOM CUSHION	1	
	P4	AMZ01K132	CARTON BOX	1	

MMH1111