

Service Manual

Juicer

Model No. MJ-DJ01

Destination : CHINA, HONGKONG, VIETNAM, RBD, SINGAPORE, MALAYSIA, THAILAND, CIS, UK, EUROPE, PGF, SAUDI ARABIA, UAE, KUWAIT, NIGERIA

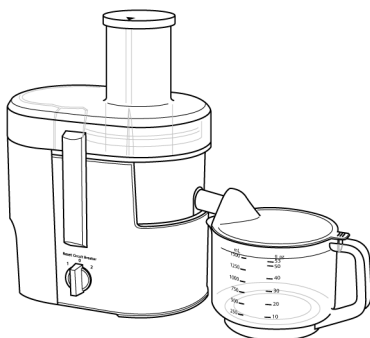

⚠ WARNING

This service information is designed for experienced repair technicians only and is not designed for use by the general public. It does not contain warnings or cautions to advise non-technical individuals of potential dangers in attempting to service a product. Products powered by electricity should be serviced or repaired only by experienced professional technicians. Any attempt to service or repair the product or products dealt with in this service information by anyone else could result in serious injury or death.

IMPORTANT SAFETY NOTICE

There are special components used in this equipment which are important for safety. These parts are marked by **⚠** in the Schematic Diagrams, Circuit Board Diagrams, Exploded Views and Replacement Parts List. It is essential that these critical parts should be replaced with manufacturer's specified parts to prevent shock, fire or other hazards. Do not modify the original design without permission of manufacturer.

TABLE OF CONTENTS

	PAGE	PAGE
1 Specifications	2	
2 Schematic Diagram	3	
2.1. With EMC	3	
2.2. Without EMC	4	
3 Basic Wiring Diagram	4	
4 Troubleshooting Guide	5	
4.1. The Juicer commons	5	
4.2. The Juicer	5	
5 Disassembly Instructions	7	
5.1. Disassembly Procudere	7	
6 Exploded View and Replacement Parts List	9	
6.1. Exploded View	9	
6.2. Replacement Parts List	10	

1 Specifications

MODEL	MJ-DJ01SSD-HK, MJ-DJ01SSQ-CN,	MJ-DJ01SRA-VN, MJ-DJ01SSG-BD, MJ-DJ01SSG-BN, MJ-DJ01SSG-LA, MJ-DJ01SSG-LK, MJ-DJ01SSG-MM, MJ-DJ01SSP-SG, MJ-DJ01SSL-MY, MJ-DJ01SSN-TH, MJ-DJ01STQ-RU, MJ-DJ01SXC-GB, MJ-DJ01SXE-DE, MJ-DJ01STN-AE, MJ-DJ01STN-AF, MJ-DJ01STN-EG, MJ-DJ01STN-LB, MJ-DJ01STN-OM, MJ-DJ01STN-PK, MJ-DJ01STN-QA, MJ-DJ01STZ-KW, MJ-DJ01STZ-NG, MJ-DJ01STZ-SA
Power supply	220 V ~ 50-60 Hz	220 V - 240 V ~ 50-60 Hz
Power consumption	240 W	240 - 270 W
Operation rating	Continuous {Repetition 2 min. ON, 2 min. OFF}	
Dimensions(HxWxD) (approx.)	384 mm x 216 mm x 305 mm	
Weight (approx.)	4.1 kg	4.4 kg
Attachments	1.5 L Juice Cup, 2.0 L Pulp Container	
Rotary switch	2 Speed	

2 Schematic Diagram

2.1. With EMC

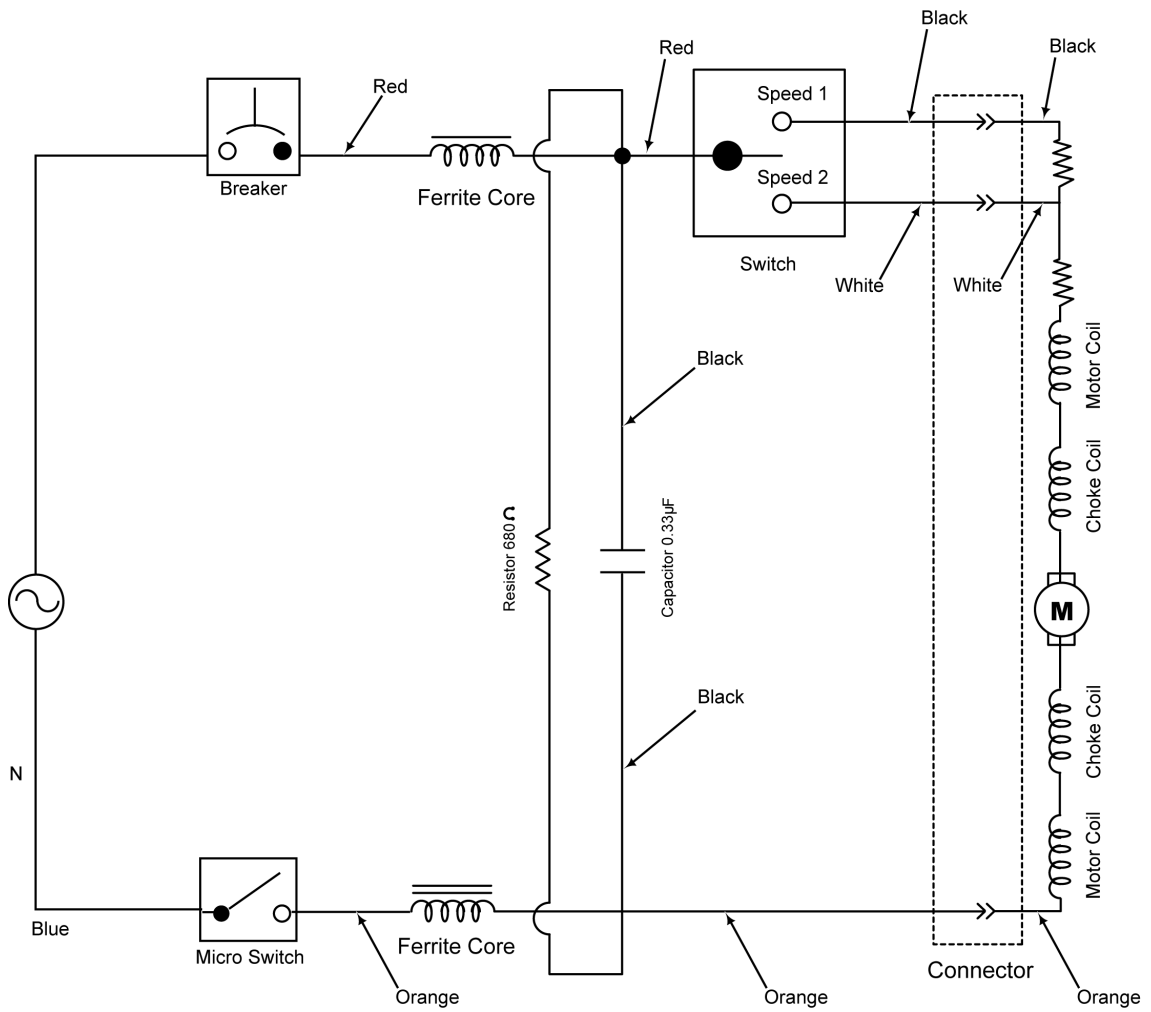

2.2. Without EMC

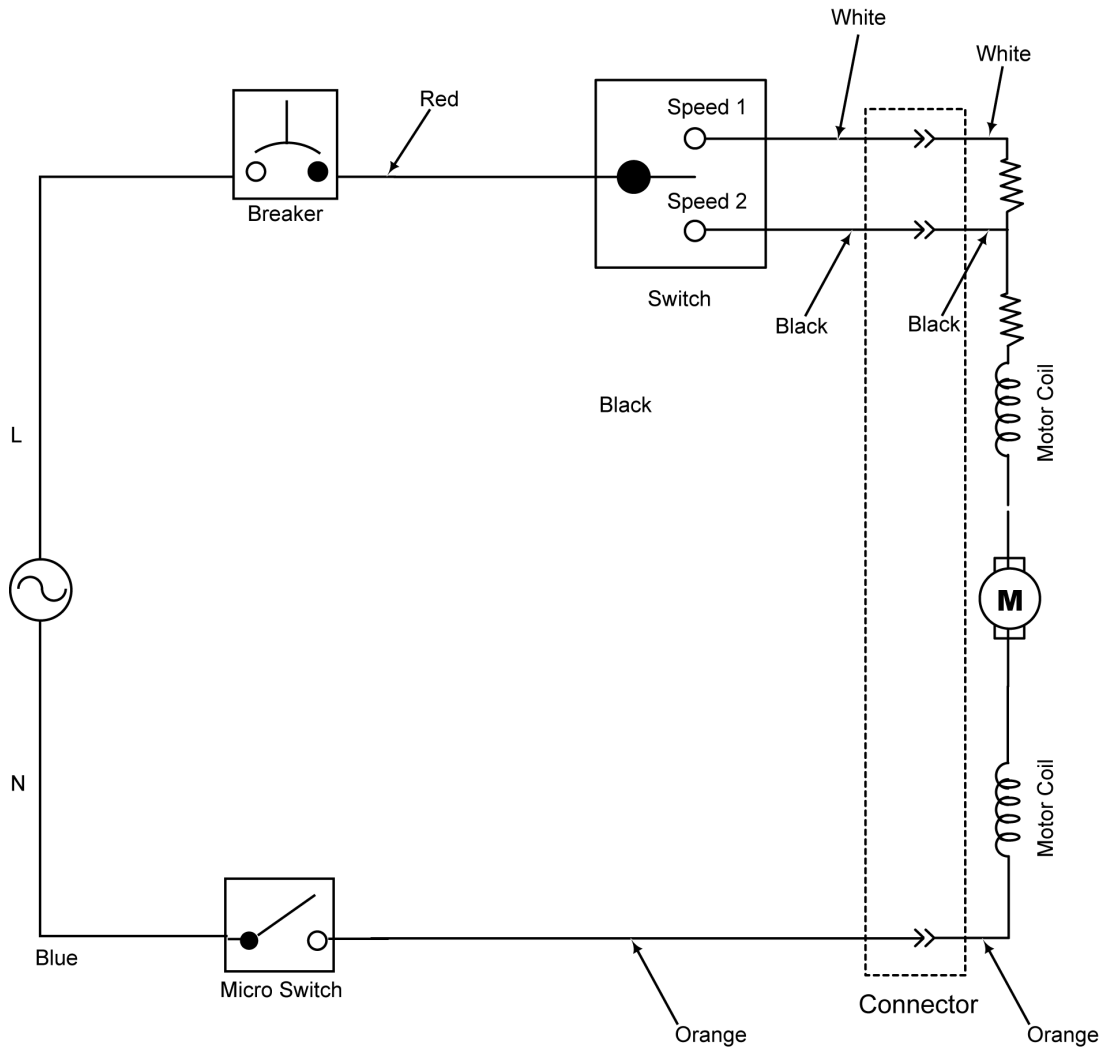

3 Basic Wiring Diagram

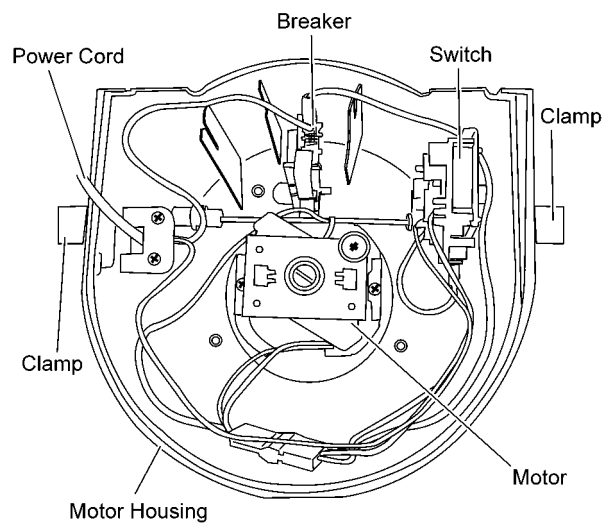

4 Troubleshooting Guide

4.1. The Juicer commons

4.1.1. SYMPTOM : Motor doesn't rotate

Cause	Remedy
Switch malfunction	Replace the switch
Cord cut or disconnected	Replace the cord

4.1.2. SYMPTOM : Motor "roars" but doesn't rotate. (Turn the switch off immediately)

Cause	Remedy
Motor bearing rushed	Disassemble and apply oil, or replace the motor

4.1.3. SYMPTOM : Motor overheats

Cause	Remedy
High voltage	Adjust it
Shorted motor	Replace the motor
Unloaded operation	Be sure that something is in the container before operating
Overload (rotation is impeded by a hard object, or a high viscosity substance in the container)	Refer to operation

4.1.4. SYMPTOM : Unusual odor

Cause	Remedy
Overheating	Refer to the section concerning overheating of the motor
Liquid leaking into motor	Refer to the section concerning liquid leakage
Motor absorbing moisture	Dry the motor or replace it

4.2. The Juicer

4.2.1. SYMPTOM : Motor "roars" but doesn't rotate. (Switch off immediately)

Cause	Remedy
The spinner is contacting bottom of inlet	After removing cutter base, decrease the number of adjustment rings
Foreign materials are clogged between the spinner and the cutter	Remove them
Hard materials or seeds are clogged between the inlet bottom and the cutter	Remove them

4.2.2. SYMPTOM : Noise, vibration

Case	Remedy
Deformation of spinner	Replace the spinner
Residue has collected unevenly	Clean the spinner
Incompletely fastened clasp	Fasten it completely Replace it
The fastening part of the container cover clasp is worn out	Replace the cover
Incompletely fastened back cover	Fasten it completely
Incorrect placement of the main unit	Inspect the rubber feet Use on a level surface

4.2.3. SYMPTOM : The spinner is difficult to install and remove

Cause	Remedy
The clutch pin of the cutter base doesn't operate smoothly	Examine the clutch pin; replace it if necessary
Foreign materials are clogged between the cutter base and the spinner base	Remove them

4.2.4. SYMPTOM : Juice is poorly extracted

Cause	Remedy
Cutter doesn't operate well	Replace complete spinner
Spinner is broken	Replace complete spinner
Continuous use for a long period	Remove the residue
Too large a gap between inlet bottom and cutter blade	Adjust it within the range of 1.0 - 1.4mm

4.2.5. SYMPTOM : Juice contains too much residue

Cause	Remedy
Cutter blade is worn out	Replace the spinner (complete)
Gap between inlet bottom and cutter blade is too large	Use two or three adjusting washers on the motor shaft

4.2.6. SYMPTOM : Cutter rubs against inlet bottom

Cause	Remedy
Gear incompletely engaged between cutter base and spinner	Engage the gear
Too many adjustment rings on the motor shaft	Decrease the number of adjustment rings and adjust the gap within the range of 1.0 - 1.4mm

4.2.7. SYMPTOM : Leakage of juice

Cause	Remedy
Container and/or cover deformed or broken	Replace the container or cover
Incorrect clasp fastening	Examine the clasp; adjust the fastening force
Foreign materials are clogged between the container cover and the container	Clean it and remove them
Excessive vibration	Clean it and adjust the spinner balance

5 Disassembly Instructions

5.1. Disassembly Procedure

Step 1 Unscrew 4 screws from Bottom Plate.

Step 2 Remove Power Knob A Assy.

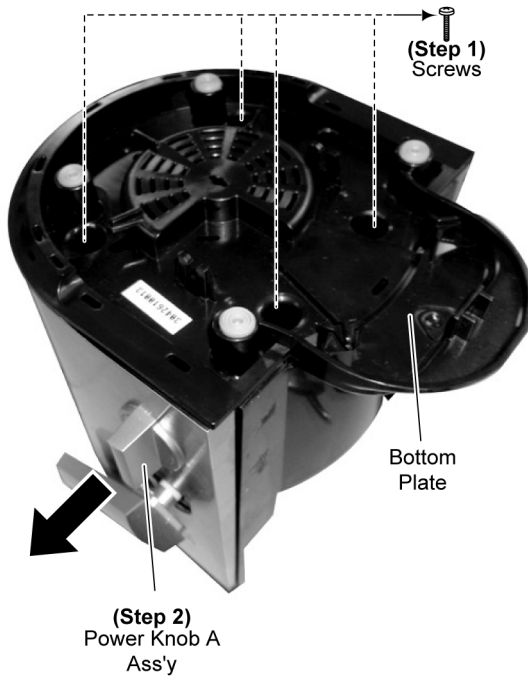

Step 6 Detach Connector.

Step 7 Remove Switch Assy.

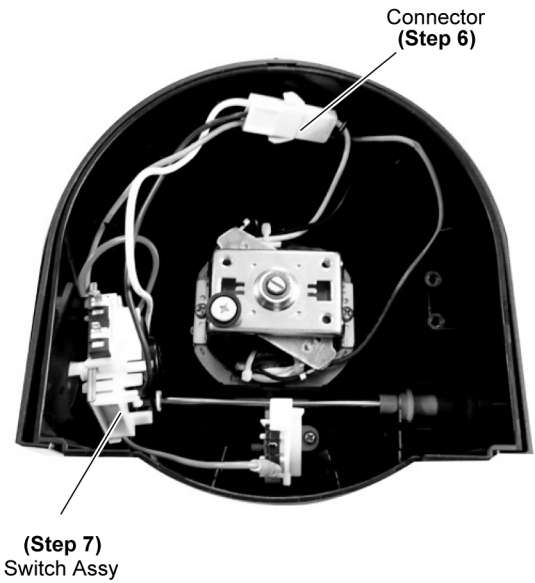

Step 8 Release Clip.

Step 9 Release Rod.

Step 3 Unscrew 3 screws from Cord Holder.

Step 4 Detach Connector.

Step 5 Detach Connector.

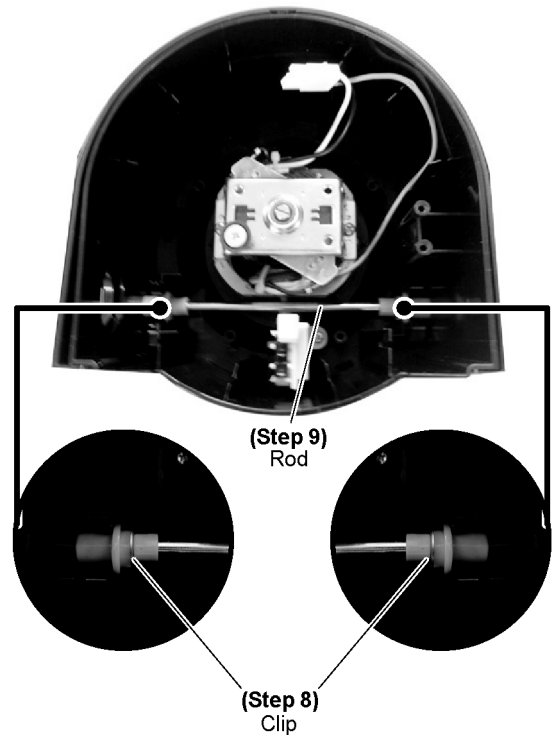
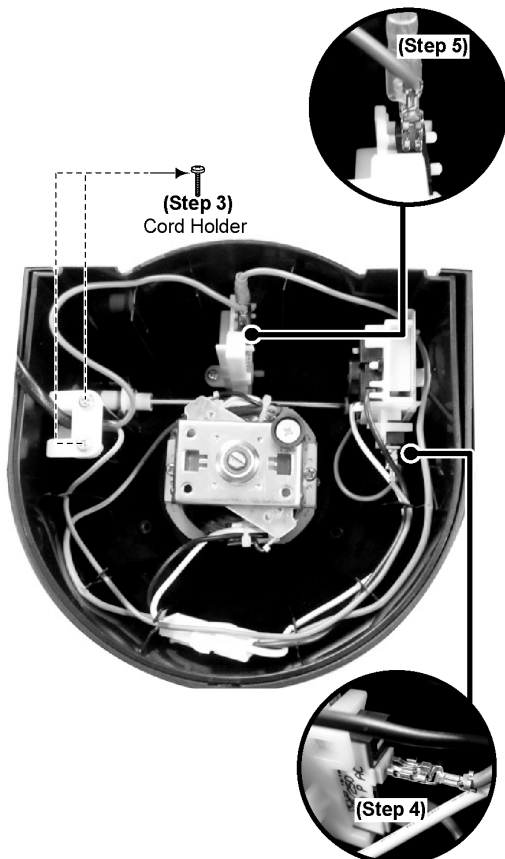

Step 10 Unscrew 3 screws.

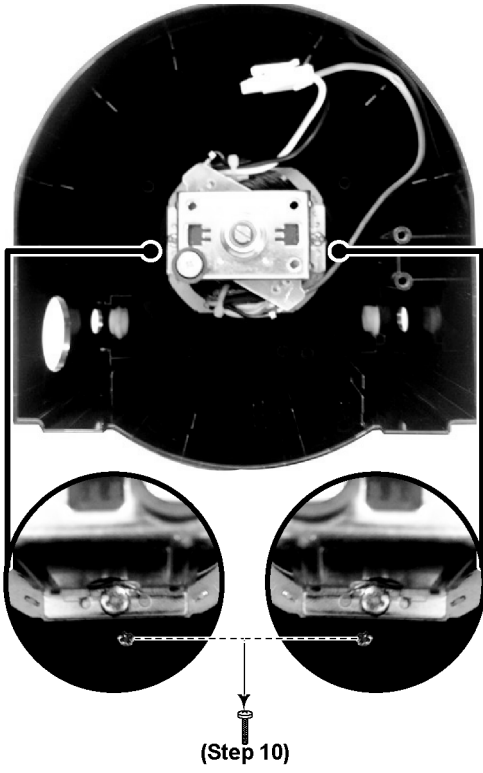

Step 11 Remove Connector Complete.

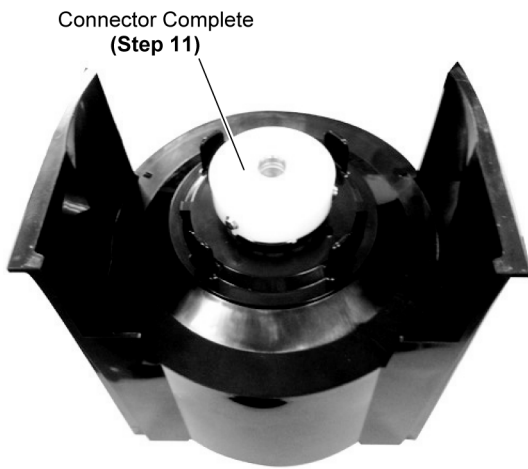

6 Exploded View and Replacement Parts List

6.1. Exploded View

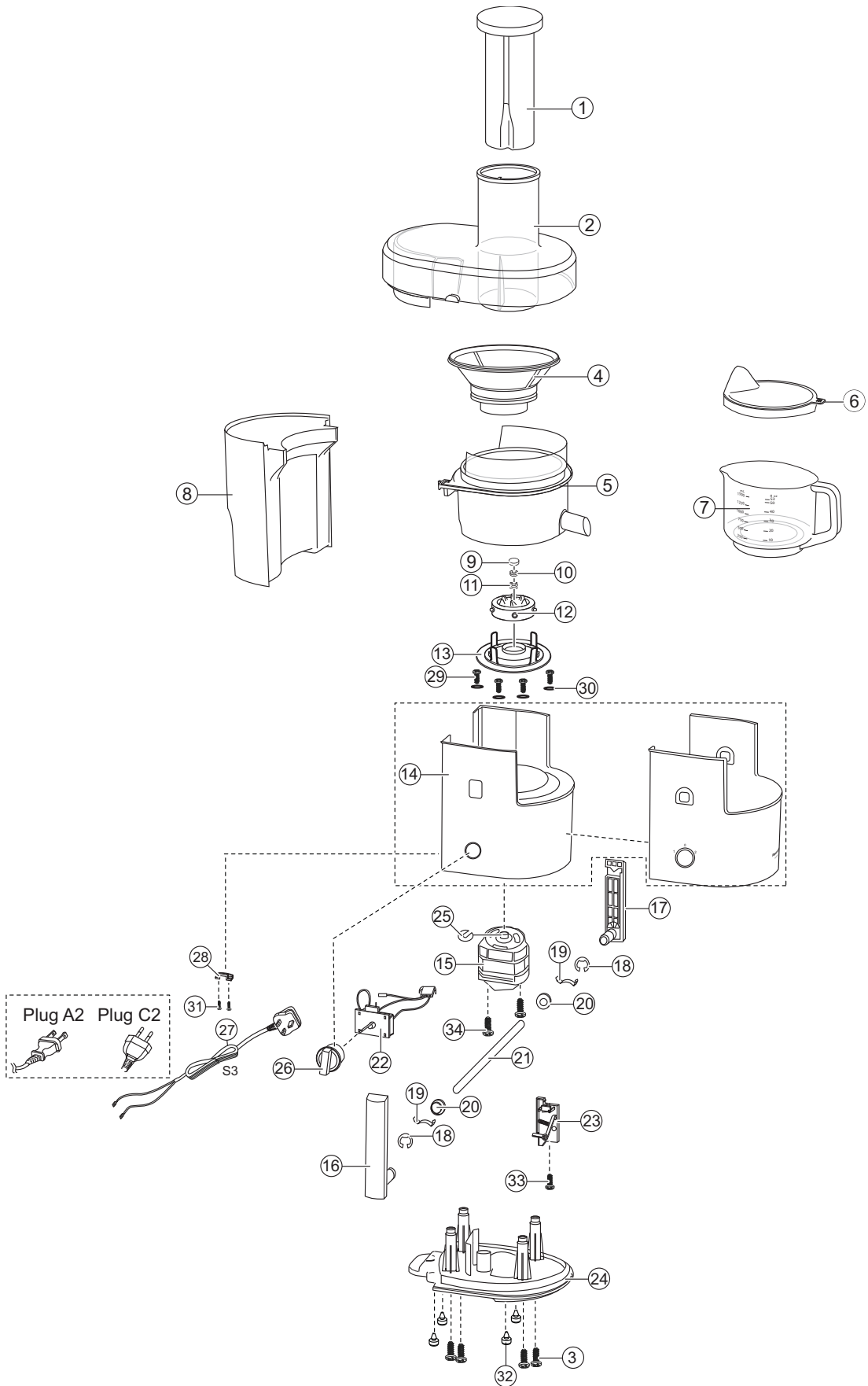

6.2. Replacement Parts List

Safety	Ref. No.	Part No.	Part Name & Description	Qty	Remarks
	1	AJD58-151-K0	PLUNGER UNIT	1	
	2	AJD89P151-K0	CONTAINER LID UNIT	1	
	3	AJJ12-1511	STAR SHAPE SCREW	4	
△	4	AJA04-151	SPINNER COMPLETE	1	
	5	AJD98-151-K0	CONTAINER ASSY	1	
	6	AJD87-151-K0	JUICER CUP COVER UNIT	1	
	6	AJD87P151-K0	JUICER CUP COVER UNIT	1	MJ-DJ01SSQ MJ-DJ01SXC & MJ-DJ01SXE
	7	AJD05-151-X0	JUICER CUP	1	
	8	AJD24-151-K0	PULP CONTAINER	1	
	9	AJF03-123	CONNECTOR CAP RUBBER	1	
	10	AJF02M1141	NUT	1	
	11	AJJ03M1141	TOOTH LOCK WASHER	1	
	12	AJ07QA0600	CONNECTOR COMPLETE	1	
	13	AJA14-151-K0	JUICER ATTACHMENT RIB	1	
	14	AJA94P151-K0	MOTOR HOUSING PANEL ASS'Y	1	MJ-DJ01SSQ & MJ-DJ01SSD (CHINESE)
	14	AJA94E151-K0	MOTOR HOUSING PANEL ASS'Y	1	MJ-DJ01SRA, MJ-DJ01SSG, MJ-DJ01SSP, MJ-DJ01SSL, MJ-DJ01SSN, MJ-DJ01SXC, MJ-DJ01SXE, MJ-DJ01STN & MJ-DJ01STZ (ENGLISH)
	14	AJA94K151-K0	MOTOR HOUSING PANEL ASS'Y	1	MJ-DJ01STQ (RUSIA)
△	15	AHC8820A230601B	MOTOR ASS'Y	1	MJ-DJ01SRA, MJ-DJ01SSG, MJ-DJ01SSP, MJ-DJ01SSL, MJ-DJ01SSN, MJ-DJ01STN & MJ-DJ01STZ
△	15	AHC8820A230601	MOTOR ASS'Y	1	MJ-DJ01SSQ, MJ-DJ01SSD, MJ-DJ01STQ, MJ-DJ01SXC & MJ-DJ01SXE
	16	AJG98-151-S2	CLAMP B UNIT	1	
	17	AJG99-151-S2	CLAMP A UNIT	2	
	18	XUC9FJ	E-RING	2	
	19	AJG05-151	CLAMP SPRING	2	
	20	AJG09-151	SPACER	1	
	21	AJG06-151	CLAMP SHAFT	1	
△	22	AJN96K151	COMPLETE SWITCH ASS'Y	1	MJ-DJ01SSQ, MJ-DJ01SSD, MJ-DJ01STQ, MJ-DJ01SXC & MJ-DJ01SXE
△	22	AJN96V151	COMPLETE SWITCH ASS'Y	1	MJ-DJ01SRA, MJ-DJ01SSG, MJ-DJ01SSP, MJ-DJ01SSL, MJ-DJ01SSN, MJ-DJ01STN & MJ-DJ01STZ
	23	AJG92-151	MICRO SWITCH ASS'Y	1	
	24	AJB98-151-K0	BOTTOM PLATE UNIT	1	
	25	XUE6FP	U-CLIP	1	
	26	AJN97-151-S2	ROTARY KNOB ASS'Y	1	
△	27	AJP99H151-K0	POWER CORD (S3)	1	MJ-DJ01SSD, MJ-DJ01STQ, MJ-DJ01SXC & MJ-DJ01STZ
△	27	AJP99M151-K0	POWER CORD (C2)	1	MJ-DJ01SRA, MJ-DJ01SSG, MJ-DJ01SSP, MJ-DJ01SSL, MJ-DJ01SXE & MJ-DJ01STN
	27	AJP99P151-K0	POWER CORD (A2)	1	MJ-DJ01SSQ & MJ-DJ01SSN
	28	AJB13-151	CORD CLIP	4	
	29	AMX56A98100	MOTOR SCREW	4	
	30	AJB06M114	MOTOR SCREW RUBBER	2	
	31	XTN4+16BFJ	PAN HEAD TAPPING SCREW	1	
	32	AJ33A53000	FOOT	1	
	33	XTN4+16BFJ	PAN HEAD TAPPING SCREW	2	

Safety	Ref. No.	Part No.	Part Name & Description	Qty	Remarks
	34	XTN4+16BFJ	PAN HEAD TAPPING SCREW		
			PACKING SPECIFICATIONS	1	
		AJZ01P151	CARTON BOX	1	MJ-DJ01SSQ
		AJZ01H151	CARTON BOX	1	MJ-DJ01SSD
		AJZ01Z151	CARTON BOX	1	MJ-DJ01SRA, MJ-DJ01SSG, MJ-DJ01SSP, MJ-DJ01SSN, MJ-DJ01SSL, MJ-DJ01STN & MJ-DJ01STZ
		AJZ01K151	CARTON BOX	1	MJ-DJ01STQ
		AJZ01G151	CARTON BOX	1	MJ-DJ01SXC & MJ-DJ01SXE
		AJZ02M151	LEFT CUSTION	1	
		AJZ03M151	RIGHT CUSHION	1	
△		AJZ50P151	OPERATING INSTRUCTION	1	MJ-DJ01SSQ
△		AJZ50Y151	OPERATING INSTRUCTION	1	MJ-DJ01SSD, MJ-DJ01SSG, MJ-DJ01SSP, MJ-DJ01STN & MJ-DJ01STZ
△		AJZ50T151	OPERATING INSTRUCTION	1	MJ-DJ01SSN, MJ-DJ01SSL & MJ-DJ01SRA
△		AJZ50K151	OPERATING INSTRUCTION	1	MJ-DJ01STQ
△		AJZ50G151	OPERATING INSTRUCTION	1	MJ-DJ01SXC & MJ-DJ01SXE
		AJZ05-151	SPINNER PAD	1	

MMH1305