

# Service Manual

## Electronic Warm Jar

**SR-DE103 / SR-DE183**  
**SR-MS103 / SR-MS183**

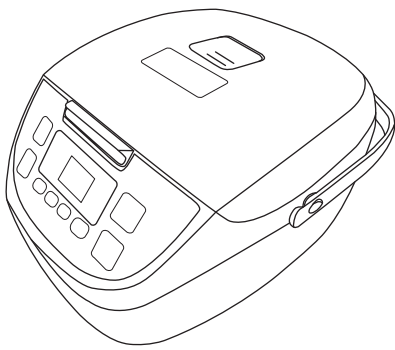

**SR-DE103 / SR-DE183**

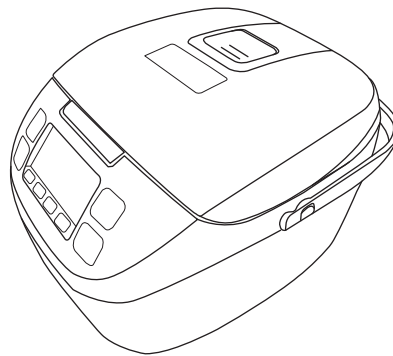

**SR-MS103 / SR-MS183**

**Product Colour**  
White (W)

### Destination

Thailand, Hong Kong, Malaysia,  
Singapore (RBD), Indonesia, PSV,  
Singapore (DBD), Taiwan,  
USA & Canada, Panama,  
Australia & New Zealand.

### IMPORTANT SAFETY NOTICE

There are special components used in this equipment which are important for safety. These parts are marked by  in the Schematic Diagrams, Circuit Board Diagrams, Exploded Views and Replacement Parts List. It is essential that these critical parts should be replaced with manufacturer's specified parts to prevent shock, fire or other hazards. Do not modify the original design without permission of manufacturer.

---

# CONTENT

---

	<b>Page</b>
1. Warning	3
2. Specification	4
3. Diagram	
3.1 Circuit Diagram	
3.1.1 SR-DE103 / SR-DE183	5
3.2.1 SR-MS103 / SR-MS183	6
3.2 Block Diagram	7
3.3 Wiring Diagram	8
4. Troubleshooting	
4.1 Before troubleshooting	9
4.2 Self-diagnosing	9
5. Troubleshooting-Part I (for the main unit)	10
6. Quick Check Test for the Control Board	11
7. Troubleshooting-Part II (for the P.C.B.)	12
8. Test Method	
8.1 Bubble Test	13
8.2 Steaming Test	13
8.3 Keep Warm Test	13
9. Replacing of P.C.B. (Comp.)	14 - 16
10. Replacing of Cast Heater	17
11. Replacing of Pan Sensor and Thermal Fuse	18
12. Parts Exploded View and Replacement Parts List	
12.1 Part Exploded View	19
12.2 Packing View	20
12.3 Replacement Parts List : SR-DE103 / SR-DE183	21 - 22
12.4 Replacement Parts List : SR-MS103 / SR-MS183	23 - 24

# 1. WARNING

## WARNING

The service information is designed for experienced repair technicians only and is not designed for use by the general public. It does not contain warnings or cautions to advise non-technical individuals of potential dangers in attempting to service a product. Products powered by electricity should be serviced or repaired only by experienced professional technicians. Any attempt to service or repair the product or products dealt within this service information by anyone else could result in serious injury or death.

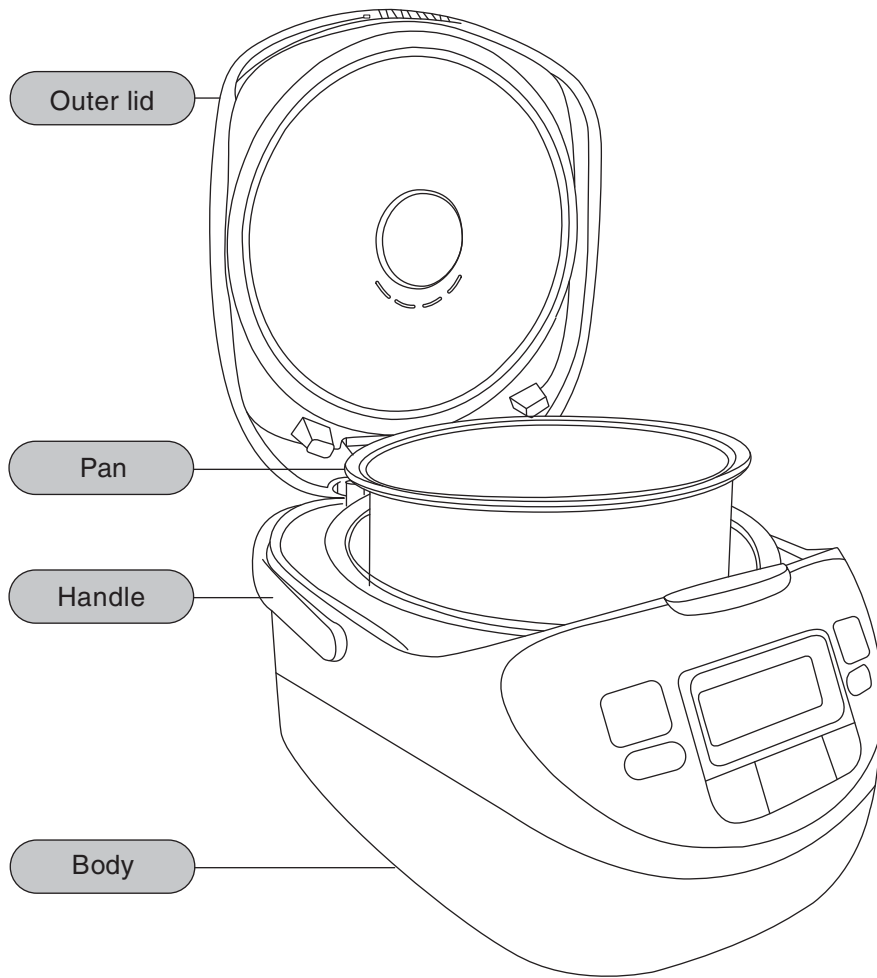

## Accessory

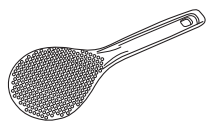

Scoop



Measuring cup

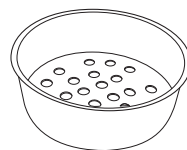

Steaming basket

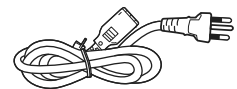

Power cord

## 2. SPECIFICATION

MODEL		SR-DE103	SR-DE183	SR-MS103	SR-MS183
Colour Name		White	White	White	White
Colour Code		W	W	W	W
Power Supply	110V/60Hz	Taiwan	Taiwan	Taiwan	Taiwan
	120V/50Hz	USA & Canada Panama	-	USA & Canada	USA & Canada
	220V/50Hz	Thailand Hong Kong	Thailand Hong Kong, PSV Singapore (RBD) Indonesia	Thailand Hong Kong, PSV Singapore (RBD)	Thailand Hong Kong, PSV Singapore (RBD)
	230V/50Hz	Singapore (DBD)	Singapore (DBD)	Singapore (DBD)	Singapore (DBD)
	240V/50Hz	Malaysia, AUS/NZ	Malaysia, AUS/NZ	AUS/NZ	AUS/NZ
Power Consumption	Cooking	750W	750W	750W	750W
	Keeping Warm	70W	80W	77W	87W
Cooking Capacity	White Rice	1 ~ 5 cups	2 ~ 10 cups	1 ~ 5 cups	2 ~ 10 cups
Product Dimension	Width	274 mm	274 mm	274 mm	274 mm
	Depth	351 mm	351 mm	351 mm	351 mm
	Height	197 mm	245 mm	197 mm	245 mm
Weight	Approx.	2.8 Kg	3.1 Kg	2.6 Kg	3.0 Kg
Keep Warm Temperature	USA & Canada Panama	73 ± 4 °C			
	Indonesia	77 ± 4 °C			
	Others	75 ± 4 °C			
Center Thermostat Working Temperature		127 ± 6 °C			
Thermal Fuse Specification		172 °C			
Accessories		Steaming basket, Scoop, Measuring cup, Power cord			
* If any change occurred to the appearance, wiring or other parts of the warm jar due to property improvement or other reasons, there will be additional notice.					

# 3. DIAGRAM

## 3.1 Circuit Diagram

### 3.1.1 SR-DE103 / SR-DE183

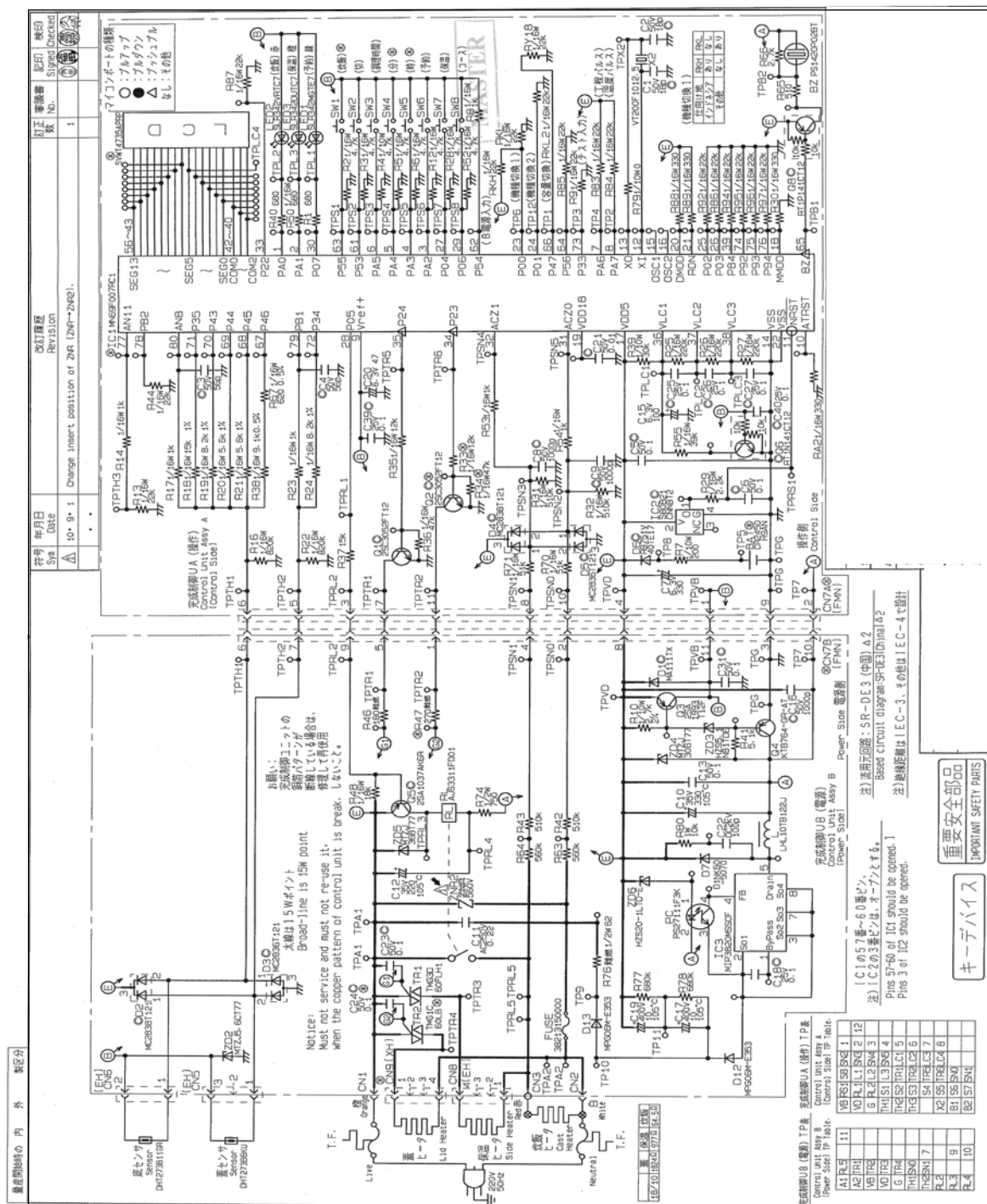

Unit:mm

3.1.2 SR-MS103 / SR-MS183

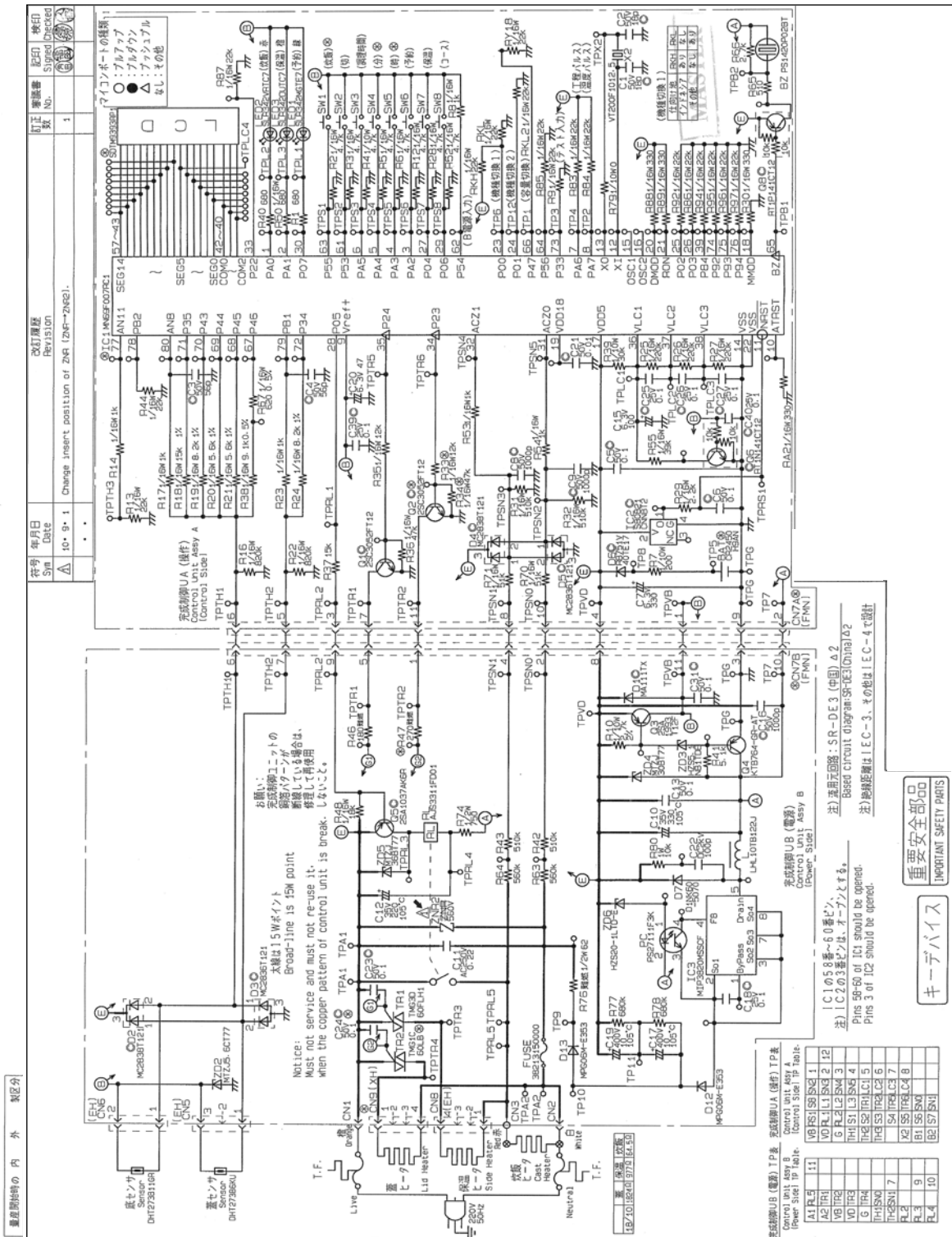

Unit:mm

### 3.2 Block Diagram

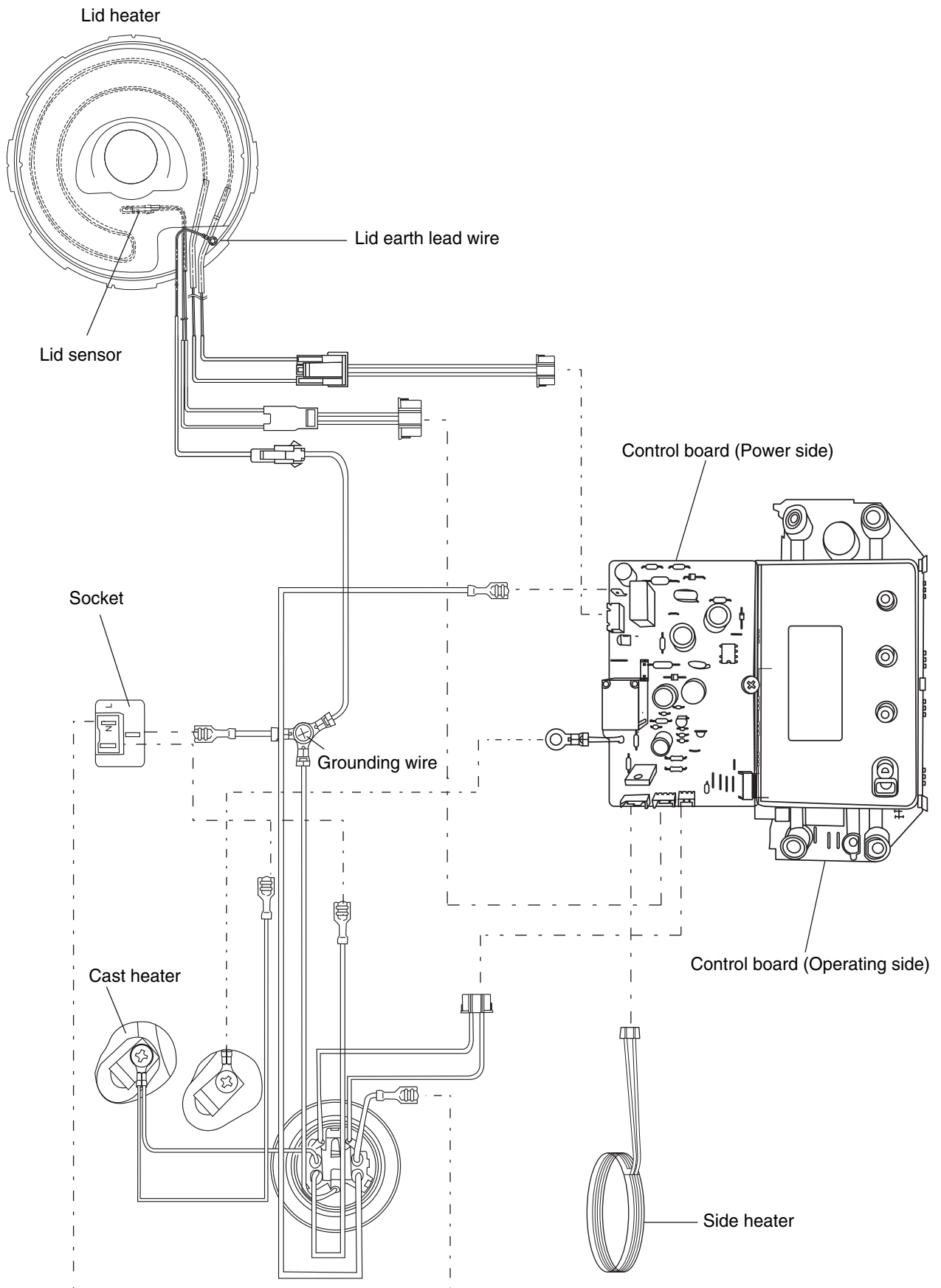

### 3.3 Wiring Diagram

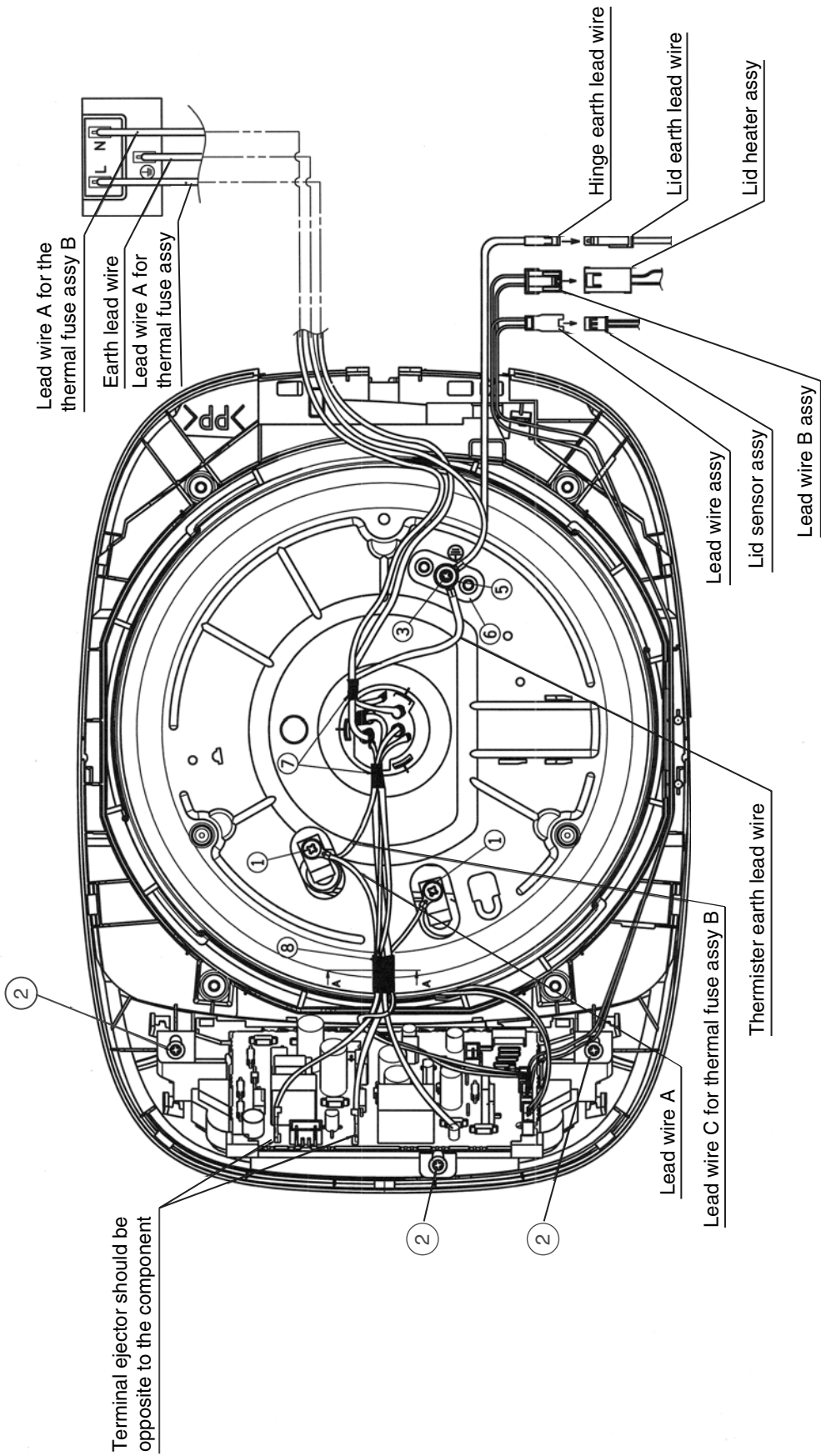



## 4. TROUBLESHOOTING

Before repairing the warm jar from users, please confirm whether it is complete (pan, lid, keep warm pin, etc.) and inquiry the user for specific malfunctions. Please turn off the power before checking the circuit or component.

### 4.1 Before troubleshooting

Troubleshooting will be proceeded in two steps, one for the main unit and the other for control circuit board. Please refer to part I before any checking. If the malfunctioned item is unavailable in the troubleshooting table, please proceed the basic test to check the control circuit board (refer to page 7). Then decide proper measures according to the troubleshooting description in part II.

The malfunctioned component and its location are indicated in the right side of trouble symptom.

Each component is designated with a number of checking sequence, please refer to it. Please refer to page 7 for information of diagnosing the malfunctioned parts on panel (for reference only).

#### Precautions for operating microprocessor or control circuit

The microcomputer is composed of CMOS digital IC and MOS FET, so it is quite sensitive to electrostatic, such as electrostatic from body, clothes, iron, etc. Please handle it carefully as per following instructions :

- The handling personnel should be well grounded.
- The iron should be grounded. Do not use the iron with poor insulation. The iron with microcomputer control is suggested.
- Do not touch the IC pin or other components before grounded. Do not put the circuit board on conductive surface that may be charged.
- Do not insert the components from reverse side of the circuit board.
- Do not apply high resistance (x10k) when proceeding continuous measurement with multi-meter, otherwise, the IC and other components on the circuit board may be damaged due to the high voltage.
- Try to shorten the welding time (within several seconds).
- Please turn off the power before replacing any component.
- The transformer for control panel has a voltage of AC 110V, 120V, 220V, 230V, 240V, so please take care when handling the electric control board to avoid electric shock or hurt.

### 4.2 Self-diagnosing

The following symbols will appear on LCD automatically when it is abnormal.

#### Display

Symbol	Symptom	Remedy
U14	The "Keep Warm" function is cut off automatically when the operation exceeds 96 hours.	Press [ Keep Warm / Off ] button to resume keeping warm (Do not set keeping warm for more than 12 hours).
H01	All the buttons are inoperative.	Replace the pan sensor (pan sensor is broken off), or check the branch component of pan sensor on the computer panel.
H02	All the buttons are inoperative.	Replace the pan sensor (pan sensor is broken off), or check the branch component of lid sensor on the computer panel.
H05	All the buttons are inoperative.	Replace relay or P.C.B. (Cause : The relay is in fault).

## 5. TROUBLESHOOTING-PART I (for the main unit)

Note : Mark ○ means the components that may malfunction.

Drawing No.		15	23	44	48	48	54	61	6	22									Remark	
Symptom	Malfunctioned Component	Lid Heater	Cast Heater	Warming Heater	Pan Sensor	Thermal Fuse	Terminal	AC Cord	Outer Lid Comp.	Pan									Parts on the P.C.B. ※ Refer to page 8, when the malfunctioned parts are supposed to be on the P.C.B.	
	Unit Description																			
Does not cook	Cooking LED lights up		○																○	
	Cooking LED does not light up				○	○	○	○											○	If the fuse melts, check and remove the cause firstly, then replace the malfunctioned part.
	LED does not operate at all																		○	
	Indicates "H01" on LCD				○														○	
	Indicates "H02" on LCD								○										○	
	Indicates "H05" on LCD																		○	
Cannot cook rice correctly (stops early or cooking is uneven, etc.)		○		○						○								○	This may occur due to user's improper measurement or insufficient loosening of rice.	
Rice on bottom of the inner pan is scorched		○		○						○								○	Check that there is on dirt or foreign substances stuck to the surface of the pan sensor.	
Keep Warm temperature is high (over 78 °C)					○													○		
Keep Warm temperature is low (below 68 °C)		○	○	○	○					○								○		
Does not Keep warm	Keep Warm LED lights up	○		○														○		
Droplets fall onto the surface of rice		○								○								○	This may occur by unplugging or insufficient loosening of rice.	
The surface of rice dries up				○														○	This may occur when the lid is kept open for a long time, insufficient loosening of rice or falling of "Keep Warm" pin.	
The bottom of warm jar melts and fires					○													○		

## 6. QUICK CHECK TEST FOR THE CONTROL BOARD

Check performance of the P.C.B. in the following procedure. If any failure detected, repeat the performance again. (Refer to page 8). If still abnormal, replace spare parts on the control panel or the whole control board (comp.) according to “Troubleshooting-Part II” on page 12 and “Problem Diagnosing Table” under subject of “4.2 Self-diagnosing” on page 9.

1.

Connect the unit to a power source by inserting the plug into an outlet. In the stand-by mode, press the [Start], [Menu Select] and [Keep Warm] button simultaneously with fingers.

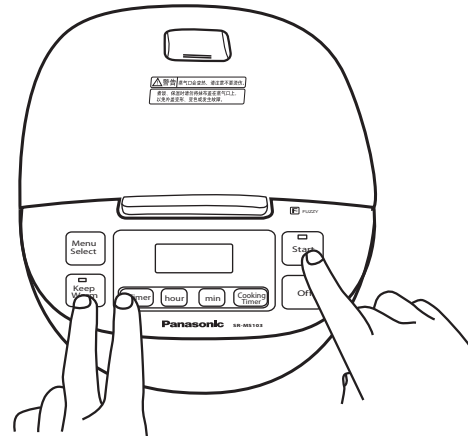

[Fig. A]

2.

With the keys pressed, if all areas on the LCD panel light up, as shown at right in Fig. B, the control board can be judged to be normal. (Releasing any or all of the three keys will cancel the test condition)

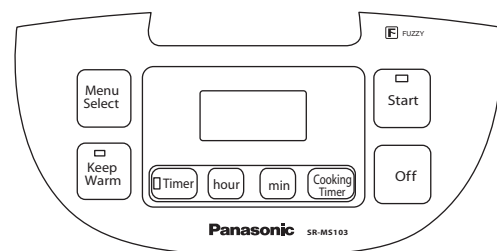

[Fig. B]

3.

When releasing the three keys, the [Hour] lights up as shown in right Fig. C and the buzzer sounds, then cooking starts. When the pan sensor temperature reaches the cooking end level, the heating operation switches to the warming mode.

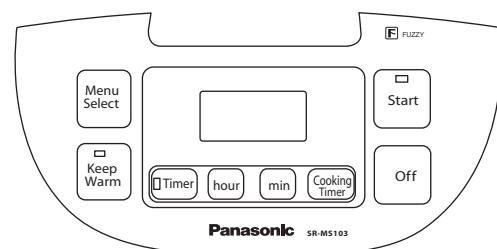

[Fig. C]

4.

Press the [Keep Warm] button. Operate and check whether other function buttons are normal.

If the above 1 to 4 operation proves to be normal, the P.C.B. comp. can be judged as OK.

## 7. TROUBLESHOOTING-PART II (for the P.C.B.)

**Note :** Mark ○ means the components that may malfunction.

Drawing No.		38	SW	LCD	X1	BZ	T	RL	TR1	BAT					Remark					
Symptom	Unit Description	P.C.B. (comp.)	Parts on the control panel																	
			Tact Switch	LCD	Cermic Resonator	Buzzer	Transformer	Relay	Triac	Flat Cable	Li Battery									
Does not cook	Cooking LED lights up	○						○			○									
	Cooking LED does not light up	○	○			○		○				○								
	LED does not operate at all	○	○			○		○				○								
Cannot cook rice correctly (stops early or cooking is uneven, etc.)		○						○												
Rice on bottom of the inner pan is scorched		○						○												
Keep Warm temperature is high (over 78 °C)		○									○									
Keep Warm temperature is low (below 68 °C)		○									○	○								
Does not Keep warm	Keep Warm LED lights up	○									○	○								
Does not keep warm continuously		○									○									
Droplets fall onto the surface of rice		○									○	○								
Buzzer does not sound	Other operations are normal	○				○														
Part of the LCD is blank		○		○																
The clock display disappears after unplugging													○							

## 8. TEST METHOD

### 8.1 Bubble test

1. Insert the pan into the cooker main body and turn it slightly clockwise and anti-clockwise to place the pan properly on top of the cast heater.
2. Pour small quantity of water into the pan so that the bottom of the pan is immersed with water. Close the lid completely.
3. After connecting to power, select [Quick] from [Menu Select] and then press [Start] button.
4. When the water boils, the cooker will blow off steam. When you see the steam, open the lid, and then press the brim of the pan to completely touch it to the cast heater. Then check the water bubbling condition.

#### See the right figures :

- Water bubbles appear at three areas and are distributed evenly around the circle.....Acceptable
- Water bubbles are distributed unevenly and not around the circle.....Unacceptable
- The unacceptable result is possibly due to incomplete contact of bottom of pan and the cast heater. So please check the heater surface for foreign material and remove them or replace the defective part (pan or cast heater).

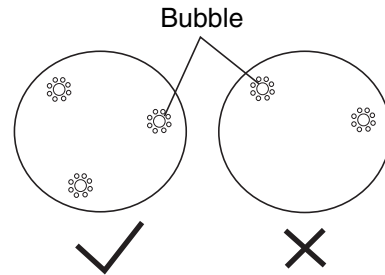

### 8.2 Steaming test

After confirming the bubble test is acceptable, spread two or three sheets of tissue paper (or gauze) over bottom of the pan to leave the cooker on without closing the lid.

#### Note :

- Be sure to fully open the lid to protect the plastic parts from thermal distortion caused by steam.
- Make holes in the tissue paper (or gauze), as shown, so that it will not float up during steaming.

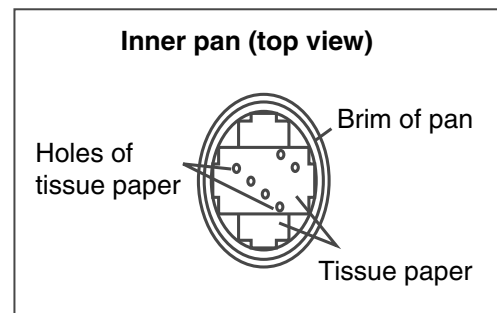

### 8.3 Keep Warm test

1. Place a mercury thermometer between urethane foam blocks as shown below. Urethane foam blocks (ASN-300) and the thermometer (ASN-150H) are supplied as spare parts.
2. Place the urethane foam blocks holding the thermometer into central bottom of the pan and allow the cooker to run in the “Keep Warm” condition for more than 1 hour.
3. More than 1 hour later, open the lid and read the temperature within 10 seconds.
  - If it is within 69°C - 77°C, then considered as normal.
  - If the warming temperature is out of this range, check whether there is any dirt or foreign material stuck on the pan sensor or bottom of the pan, if so, please remove them.
  - If nothing is found, adjust the warming temperature and replace the control circuit board (comp.)

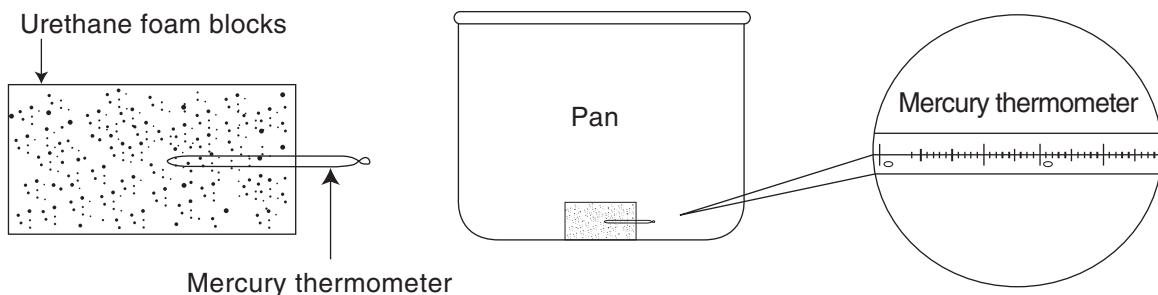

## 9. REPLACING OF P.C.B. (Comp.)

### 1. Remove the power socket (comp.)

- Open the lid and place the cooker upside down on a rubber sheet to protect it, as shown in the right figure.
- Unplug the power cord.
- Remove the screw (1) on power socket cover and take out the power socket and its cover (comp.)
- Remove the wiring of power socket (3 places).

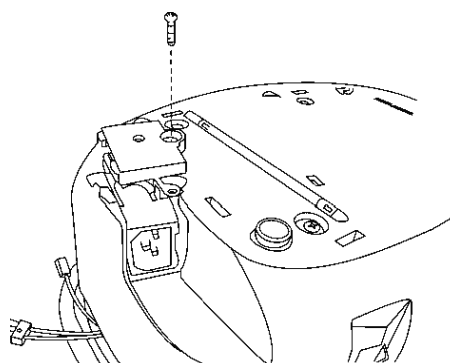

### 2. Remove the retaining screw of the body

- Remove the 4 retaining screws of the body.

Retaining screw of the body

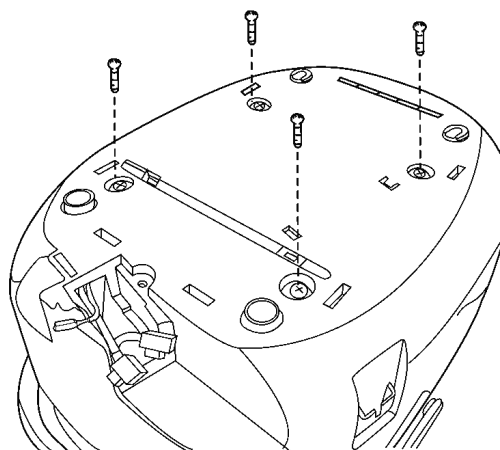

### 3. Remove the hinge cover

- Remove the retaining screw first, and then insert the screwdriver between hinge cover and body, as shown in the right figure.
- Pry the screwdriver outward like a lever to disconnect the hinge cover.

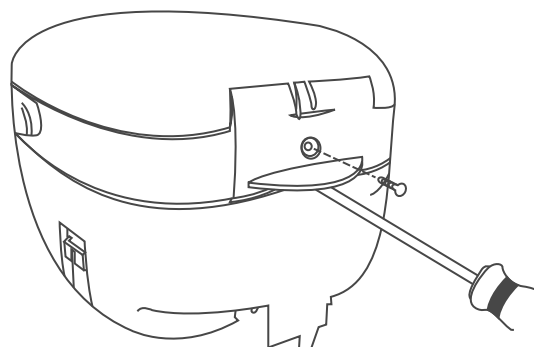

**4. Remove the body of cooker**

- Place the cooker upside down on a rubber sheet, then insert the screwdriver upright for about 30 - 40 mm., as shown in the right figure.
- Turn the screwdriver in arrow direction to remove the body, as shown in the right figure.

**Note :**

- Do not knock at the screwdriver, otherwise the parts contacted with screwdriver will be damaged. Please follow the above procedures to remove.

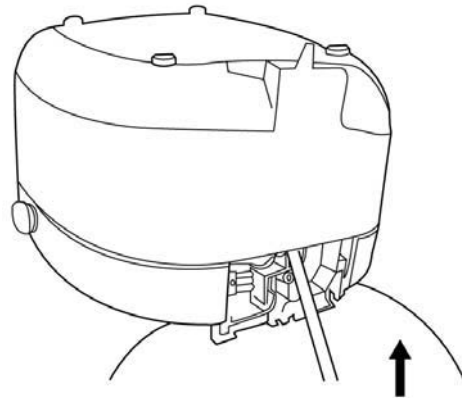
**5. Remove the wiring of P.C.B. component**

- Pull out each connector with a pincers.
- Pull out the fastening terminals (3 places) with a pincers.

**Note :**

- For connectors or thing like this, please pull outward directly. If pulled out in different directions, the coil may be damaged or P.C.B. cracks due to the pressure applied on it.
- When pulling out the fastening terminal, please press the pin down in arrow direction while pulling. Otherwise, the terminal can not be pulled out.

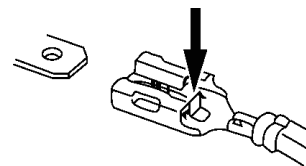
**6. Remove the P.C.B. base (comp.)**

- Remove the fire-retardant tape attached on the P.C.B.
  - Unplug the wiring connected to P.C.B.
  - Remove the retaining screw on P.C.B. base (3 places).
  - Take out the P.C.B. base directly with hand.
  - Remove another fire-retardant tape attached on the P.C.B.
- ※ Please wear an anti-static wring strap or take relative measures to prevent electric shock.

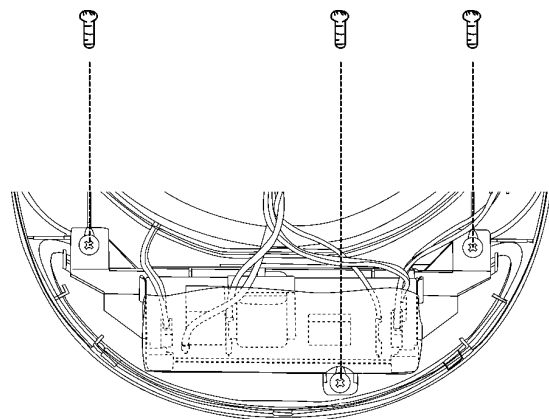

**7. Take out the P.C.B. component**

- Remove the tabs at (a) gently, then take out the P.C.B. (operating side) while lifting.
- Remove another fire-retardant tape attached on the bottom of the P.C.B.
- Remove the retaining screws gently. Then take out the P.C.B. (power side) while lifting.

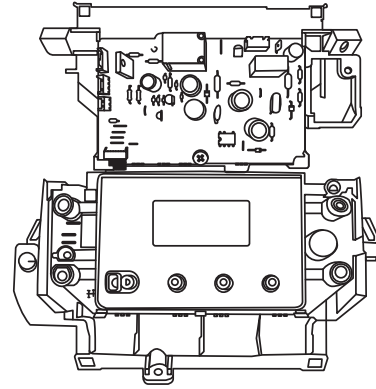
**8. Assembly of P.C.B. base (comp.)**

- When assembling the P.C.B. base (comp.), please proceed in reverse to disassembly.

**Note :**

- When reassembling, make sure to attach the fire-retardant tapes as what they are before removing.



## 10. REPLACING OF CAST HEATER

### 1. Remove the power socket (comp.) and body

- Remove the power socket and body in referring to replacing of P.C.B. base (comp.)

### 2. Remove the base of sensor

- Tear off the retaining tapes (2 places) on the wiring of the pan sensor.
- Remove the connections (2 places) between pan sensor and P.C.B.
- Remove the wiring (1 place) connected between pan sensor and cast heater.
- Remove the connection (1 place) between cast heater and P.C.B.
- Remove the grounding wire.
- Remove the connections (3 places) on base of sensor.
- Take out the base of sensor.

### 3. Remove the cast heater

- Remove the retaining screw of cast heater (3 pieces).
- Take out the cast heater from protection frame.

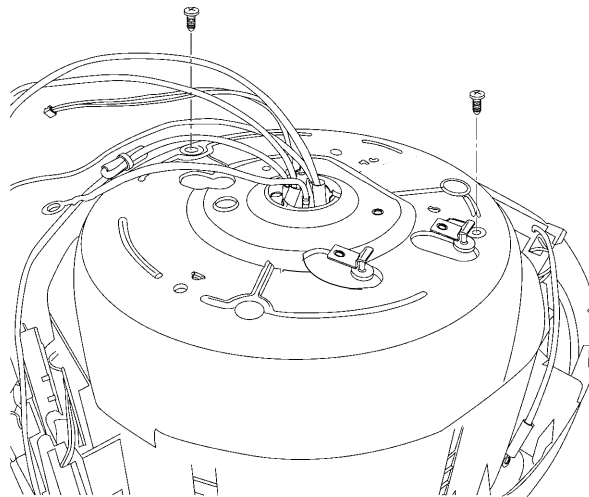

### 4. Reassembly

- Please reassemble the cast heater in reverse to disassembly.

**Note :**

- When reassembling, make sure to attach the fire-retardant tapes as what they are before removing.

## 11. REPLACING OF PAN SENSOR AND THERMAL FUSE

### 1. Remove the cast heater

- Remove the cast heater in referring to replacing of cast heater.

### 2. Remove the pan sensor

- Upright the tabs (3 places) as shown in the right figure, then take out the pan sensor.

**Note :**

- Do not deform the spring when removing.

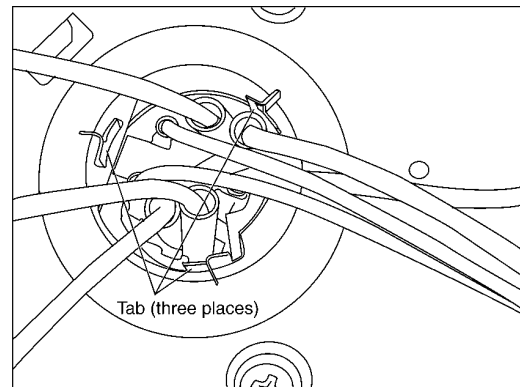

### 3. Replacing of thermal fuse

- The procedure of replacing of pan sensor is actually a procedure of replacing of thermal fuse A/B, for they both fixed inside of pan sensor.

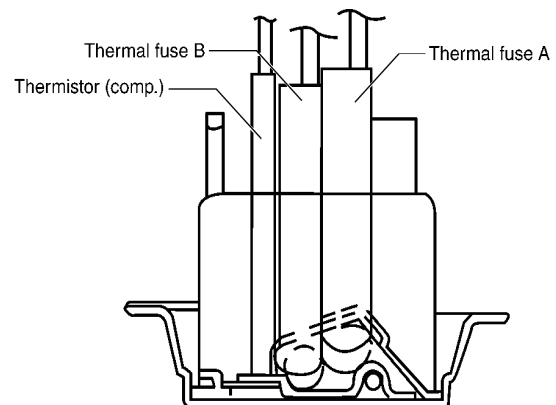

### 4. Reassembly

- Please reassemble the pan sensor in reverse to disassembly.

**Note :**

- Do not deform the spring when assembling.
- Do not slant the spring when assembling.
- Check the direction of pan sensor.

# 12. PARTS EXPLODED VIEW AND REPLACEMENT PARTS LIST

## 12.1 Parts Exploded View

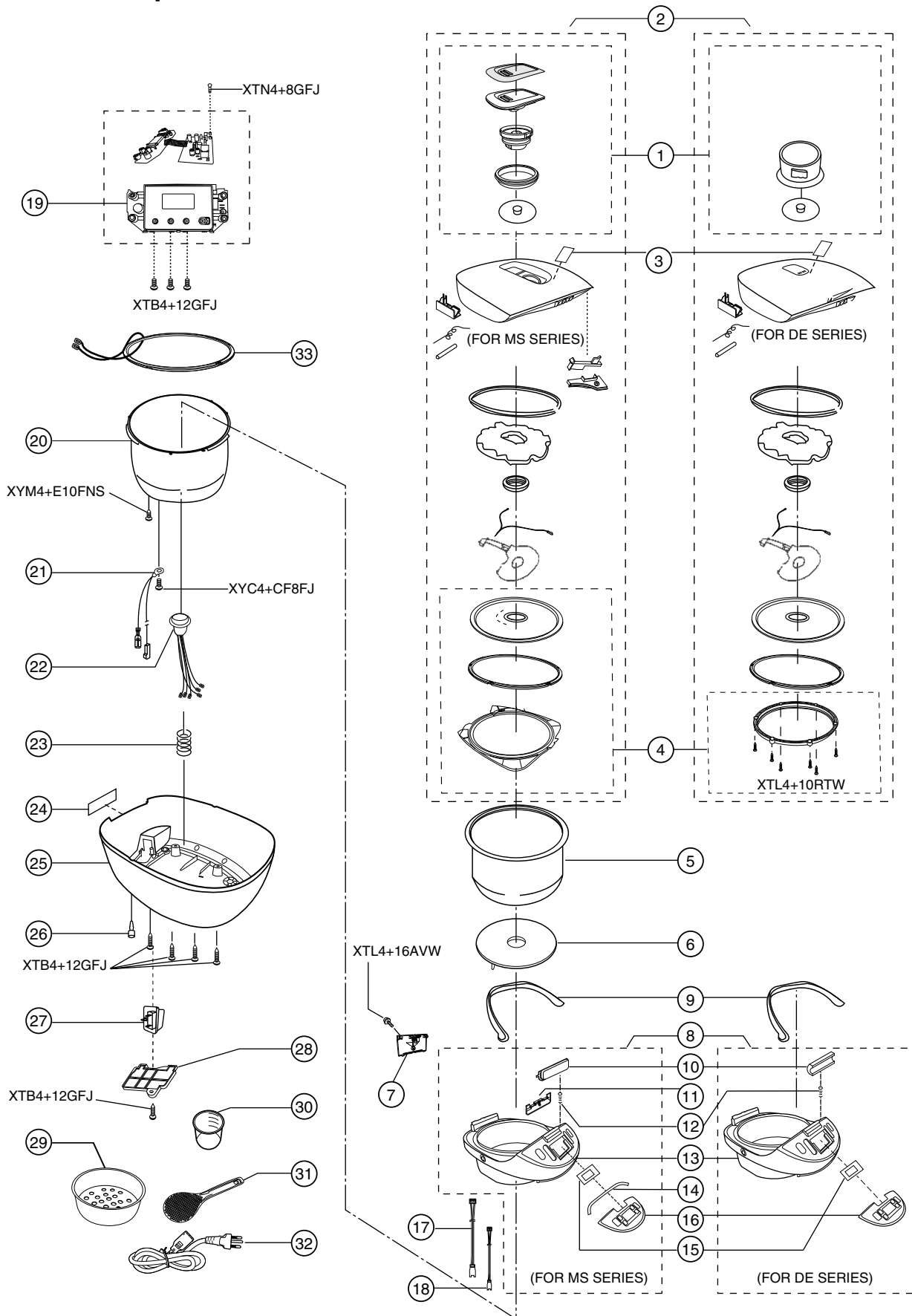

## 12.2 Packing View

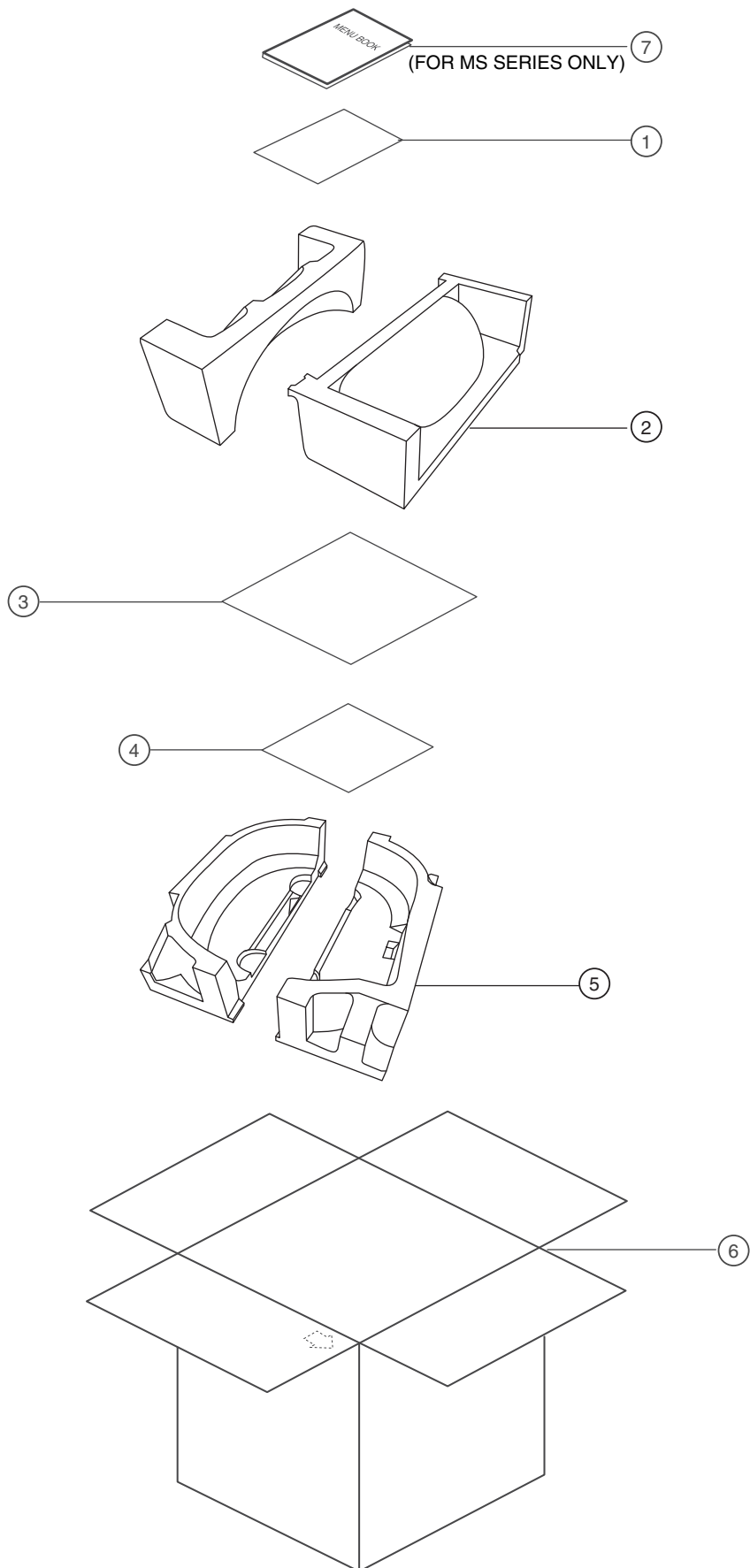

**Important safety notice :**

Components identified by mark have special characteristics important for safety.  
When replacing any of these components, use only manufacturer's specified part.

**12.3 Replacement Parts List : SR-DE103 / SR-DE183****Parts List**

REF. NO.	PART NAME	PART NO.	SAFETY	MODEL		COUNTRY / Q'TY											REMARK		
				DE103	DE183	TH	HK	PSV	SIN-RBD	INDO	SIN-DBD	MY	TW	USA/CND	PAN	AU/NZ			
1	STEAM VENT ASSY	ARB54T977-0U		•	•	1	1	1	1	1	1	1	1	1	1	1	1		
2	OUTER LID ASSY	ARB01T977W9U		•	•	1													
		ARB01H977W9U		•	•		1												
		ARB01V977W9U		•	•				1	1									
		ARB01L977W9U		•	•					1									
		ARB01S977W9U		•	•						1								
		ARB01M977W9U		•	•								1						1
		ARB01U977W9U		•	•									1					
		ARB01A978W9U		•											1				
		ARB01B978W9U		•													1		
3	LID CAUTION LABEL	ARB32T975	S	•	•	1												ENGLISH / THAI	
		ARB32H975	S	•	•		1				1	1						ENGLISH	
		ARB32V975	S	•	•			1	1										ENGLISH / VIETNAM
		ARB32L977	S	•	•					1									INDONESIAN
		ARB32A975	S	•	•									1					ENGLISH / FRENCH
		ARB32B978	S	•	•											1			ENGLISH / SPAIN
		ARB32U975	S	•	•									1					CHINESE
4	PAN PACKING HOLDER	ARH69T977-W9		•	•	1	1	1	1	1	1	1	1	1	1	1	1		
5	INNER PAN	ARE50T977		•	•	1		1	1	1	1	1						1	
		ARE50T9771		•	•		1							1					CHANGE WATER LEVEL
		ARE50T978		•	•	1					1	1							1
6	CAST HEATER ASSY	ARL20T975-0U	S	•	•	1	1	1	1	1									
		ARL20S975-0U	S	•	•							1							
		ARL20M977-0U	S	•	•								1						1
		ARL20U975-0U	S	•	•									1					
		ARL20A975-0U	S	•	•										1	1			
7	HINGE COVER	ARE40T975-W9		•	•	1	1	1	1	1	1	1	1	1	1	1	1		
8	UPPER FRAME ASSY	ARE00T977W9U		•	•	1	1	1	1	1	1	1	1	1	1	1	1		
		ARE00A978W9U		•	•										1	1			
9	HANDLE	ARB10T975-W9		•	•	1	1	1	1	1	1	1	1	1	1	1	1		
10	HOOK BUTTON	ARE05T977-W9		•	•	1	1	1	1	1	1	1	1	1	1	1	1		
12	HOOK BUTTON SPRING	ARE06EA29		•	•	1	1	1	1	1	1	1	1	1	1	1	1		
13	UPPER FRAME	ARE00T977-W9		•	•	1	1	1	1	1	1	1	1					1	
		ARE00T978-W9		•	•										1	1			
15	DECORATIVE PANEL B	ARN24T977-NK		•	•	1	1	1	1	1	1	1		1	1	1	1		
		ARN24U977-NK		•	•									1					
16	DECORATIVE PANEL	ARN21T977-AV		•	•	1	1	1	1	1	1	1						1	
		ARN21U977-AV		•	•									1					
		ARN21T978-AV		•	•	1	1					1	1		1	1	1		
		ARN21U978-AV		•	•									1					
17	LEAD WIRE A ASSY	ARN97T975-0U	S	•	•	1	1	1	1	1	1	1	1	1	1	1	1		
18	LEAD WIRE B ASSY	ARN98T975-0U	S	•	•	1	1	1	1	1	1	1	1	1	1	1	1		
19	PCB BASE ASSY	ARH01T977-0U	S	•	•	1		1	1		1	1						1	
		ARH01H977-0U	S	•	•		1												
		ARH01L977-0U	S	•	•					1									
		ARH01U977-0U	S	•	•								1						
		ARH01A978-0U	S	•	•									1	1				
20	PROTECTING FRAME COMPLETE	ARE20T975		•	•	1	1	1	1	1	1	1	1					1	
		ARE20T976		•	•	1	1				1	1	1	1	1	1	1	1	
21	HINGE EARTH LEAD WIRE	ARE46T962	S	•	•	1													
		ARE46H962	S	•	•		1	1	1	1	1	1	1					1	
		ARE46T976	S	•	•		1												
		ARE46S976	S	•	•		1				1	1	1					1	
22	THERMOSTAT ASSY	ARS10T975-0U	S	•	•	1													
		ARS10H975-0U	S	•	•		1	1	1	1	1	1						1	
		ARS10U975-0U	S	•	•								1						

**Parts List**

REF. NO.	PART NAME	PART NO.	SAFETY	MODEL		COUNTRY / Q'TY											REMARK	
				DE103	DE183	TH	HK	PSV	SIN-RBD	INDO	SIN-DBD	MY	TW	USA/CND	PAN	AU/NZ		
		ARS10U976-0U	S	•		1												
		ARS10H976-0U	S	•			1				1	1						1
		ARS10U976-0U	S	•									1					
		ARS10A976-0U	S	•										1	1			
23	OUTER SPRING	AQS61T2701		•	•	1	1	1	1	1	1	1	1	1	1	1	1	1
24	NAME PLATE	ARY30T977-W9	S	•		1												
		ARY30H977-W9	S	•		1												
		ARY30V9771W9	S	•				1										
		ARY30Y977-W9	S	•					1									
		ARY30L977-W9	S	•						1								
		ARY30S977-W9	S	•							1							
		ARY30M977-W9	S	•								1						
		ARY30U977-W9	S	•									1					
		ARY30Z977-W9	S	•														1
		ARY30T978-W9	S	•			1											
		ARY30H978-W9	S	•				1										
		ARY30S978-W9	S	•							1							
		ARY30M978-W9	S	•								1						
		ARY30U978-W9	S	•									1					
		ARY30A9781W9	S	•										1				
		ARY30B9781W9	S	•												1		
ARY30Z978-W9	S	•														1		
25	BODY	ARE10T975-W9		•		1	1	1	1	1	1	1	1				1	
		ARE10T976-W9		•		1	1				1	1	1				1	
		ARE10A976-W9		•										1	1			CHANGE MATERIAL TO PP NH601
26	FOOT RUBBER	ARH90E7221		•	•	2	2	2	2	2	2	2	2	2	2	2	2	
27	INLET	ARG10T92010U	S	•	•	1	1	1	1	1	1	1	1				1	
		ARF19T93410U	S	•										1	1			
28	INLET PLATE	ARF27T975-W9		•	•	1	1	1	1	1	1	1	1	1	1	1	1	
29	STEAMING BASKET	ARK53T975-W9		•	•	1		1	1	1	1	1	1	1	1	1	1	
		ARK53ED37WQU		•	•		1											
30	MEASURING CUP	ASR792-454BK		•	•	1	1	1	1	1	1	1	1	1	1	1	1	
31	RICE SCOOP	ARK02T975-W9		•	•	1	1	1	1	1	1	1	1	1	1	1	1	
32	POWER CORD ASSY (C-3)	ARQ00T959-0U	S	•	•	1												
		POWER CORD ASSY (SH-3)	S	•	•			1	1	1								
		POWER CORD ASSY (S-3)	S	•	•		1											
		POWER CORD ASSY (S-3)	S	•	•						1	1						
		POWER CORD ASSY (A-3)	S	•	•								1					
		POWER CORD ASSY (A-2P)	S	•	•									1	1			
POWER CORD ASSY (A-3)	S	•	•												1			
33	SIDE HEATER ASSY	ARL10T975-0U	S	•		1	1	1	1	1								
		ARL10S975-0U	S	•							1	1				1		
		ARL10U975-0U	S	•									1					
		ARL10T976-0U	S	•		1	1											
		ARL10S976-0U	S	•							1	1				1		
		ARL10U976-0U	S	•									1					
ARL10A976-0U	S	•										1	1					

### Screws

REF. NO.	PART NAME	PART NO.	SAFETY	MODEL		COUNTRY / Q'TY											REMARK		
				DE103	DE183	TH	HK	PSV	SIN-RBD	INDO	SIN-DBD	MY	TW	USA/CND	PAN	AU/NZ			
	TAPPING SCREW	XTB4+12GFJ		•	•	4	4	4	4	4	4	4	4	4	4	4	4	4	FIX BODY
	TAPPING SCREW	XTB4+12GFJ		•	•	3	3	3	3	3	3	3	3	3	3	3	3	3	FIX PCB BASE ASSY
	SEMS TAPPING SCREW	XYC4+CF8FJ		•	•	1	1	1	1	1	1	1	1	1	1	1	1	1	FIX EARTH CONNECTION
	TAPPING SCREW	XTN4+16AVW		•	•	1	1	1	1	1	1	1	1	1	1	1	1	1	FIX HINGE COVER
	TAPPING SCREW	XTB4+12GFJ		•	•	1	1	1	1	1	1	1	1	1	1	1	1	1	FIX INLET PLATE
	SEMS TAPPING SCREW	XYN4+C10FNS		•	•	1	1	1	1	1	1	1	1	1	1	1	1	1	FIX CAST HEATER ASSY
	SEMS SCREW	XYN4+C7FNS		•	•	2	2	2	2	2	2	2	2	2	2	2	2	2	FIX INTERNAL WIRING

### Packing List

REF. NO.	PART NAME	PART NO.	SAFETY	MODEL		COUNTRY / Q'TY											REMARK				
				DE103	DE183	TH	HK	PSV	SIN-RBD	INDO	SIN-DBD	MY	TW	USA/CND	PAN	AU/NZ					
1	OPERATION INSTRUCTION	ARZ19T977	S	•	•	1													ENGLISH / THAI		
		ARZ19H977	S	•	•		1												ENGLISH / CHINESE		
		ARZ19V977	S		•			1	1										ENGLISH / VIETNAMESE		
		ARZ19L9771	S		•					1									INDONESIAN		
		ARZ19S977	S	•	•						1								ENGLISH / CHINESE		
		ARZ19M977	S	•	•								1						ENGLISH / CHINESE/ MALAYSIA		
		ARZ19U977	S	•	•									1					CHINESE		
	OPERATION INSTRUCTION A	ARZ19A978-A	S	•										1	1			ENGLISH / FRENCH / CHINESE			
	OPERATION INSTRUCTION B	ARZ19A978-B	S	•										1	1			KOREAN / SPANISH			
	OPERATION INSTRUCTION	ARZ19Z977	S	•	•												1	ENGLISH / CHINESE			
2	UPPER PAD ASSY	ARZ04T975-OU		•	•	1	1	1	1	1	1	1	1	1	1	1	1	1			
3	POLYETHYLENE SHEET	ASR762T929-K		•	•	1	1	1	1	1	1	1	1	1	1	1	1	1			
4	RUST PROOF PAPER	ASR758T344B		•	•	1	1	1	1	1	1	1	1	1	1	1	1	1			
5	LOW PAD ASSY	ARZ11T975-OU		•	•	1	1	1	1	1	1	1	1	1	1	1	1	1			
6	INNER PACKING CASE	ARZ01T977-W9	S		•	1															
		ARZ01H977-W9	S		•		1														
		ARZ01V977-W9	S		•				1												
		ARZ01Y977-W9	S		•					1											
		ARZ01L977-W9	S		•						1										
		ARZ01S977-W9	S		•							1									
		ARZ01M977-W9	S		•								1								
		ARZ01U977-W9	S		•									1							
		ARZ01Z977-W9	S		•															1	
		ARZ01T978-W9	S	•			1														
		ARZ01H978-W9	S	•				1													
		ARZ01S978-W9	S	•									1								
		ARZ01M978-W9	S	•										1							
		ARZ01U978-W9	S	•											1						
		ARZ01A978-W9	S	•												1					
		ARZ01B978-W9	S	•														1			
ARZ01Z978-W9	S	•																1			

## 12.4 Replacement Parts List : SR-MS103 / SR-MS183

### Parts List

REF. NO.	PART NAME	PART NO.	SAFETY	MODEL		COUNTRY / Q'TY								REMARK
				MS103	MS183	TH	HK	PSV	SIN-RBD	SIN-DBD	TW	USA/CND	AU/NZ	
1	STEAM VENT ASSY	ARC00T975W9U		•	•	1	1	1	1	1	1	1	1	
2	OUTER LID ASSY	ARB01T975W9U		•	•	1								
		ARB01H975W9U		•	•		1							
		ARB01V975W9U		•	•			1	1					
		ARB01S975W9U		•	•					1				
		ARB01U975W9U		•	•						1			
		ARB01A975W9U		•	•							1		
		ARB01Z975W9U		•	•								1	
3	LID CAUTION LABEL	ARB32T975	S	•	•	1								ENGLISH / THAI
		ARB32H975	S	•	•		1			1			1	ENGLISH
		ARB32V975	S	•	•			1	1					ENGLISH / VIETNAM
		ARB32U975	S	•	•						1			CHINESE
		ARB32A975	S	•	•							1		ENGLISH / FRENCH
4	INNER LID ASSY	ARC80T975-0U		•	•	1	1	1	1	1	1	1	1	
5	INNER PAN	ARE50T975			•	1		1	1	1			1	
		ARE50T9751			•		1				1	1		CHANGE WATER LEVEL
		ARE50T976		•		1		1	1	1	1	1	1	
6	CAST HEATER ASSY	ARL20T975-0U	S	•	•	1	1	1	1					
		ARL20S975-0U	S	•	•					1				
		ARL20U975-0U	S	•	•						1			
		ARL20A975-0U	S	•	•							1		
		ARL20M977-0U	S	•	•								1	
7	HINGE COVER	ARE40T975-W9		•	•	1	1	1	1	1	1	1	1	
8	UPPER FRAME ASSY	ARE00T975W9U		•	•	1	1	1	1	1	1		1	
		ARE00A975W9U		•	•							1		
9	HANDLE	ARB10T975-W9		•	•	1	1	1	1	1	1	1	1	
10	HOOK BUTTON	ARE08T975-W9		•	•	1	1	1	1	1	1	1	1	
11	HOOK BUTTON SHAFT	ARE05T975-W9		•	•	1	1	1	1	1	1	1	1	
12	HOOK BUTTON SPRING	ARE09ED37		•	•	1	1	1	1	1	1	1	1	
13	UPPER NAME	ARE00T975-W9		•	•	1	1	1	1	1	1		1	
		ARE00A975-W9		•	•							1		
14	ESCUTCHEON SEAL	ARN34T975		•	•	1	1	1	1	1	1	1	1	
15	DECORATIVE PANEL B	ARN24T975-OG		•	•	1	1	1	1	1	1	1	1	
		ARN24U975-OG		•	•							1		
16	ESCUTCHEON	ARN11T975-AV			•	1	1	1	1	1		1	1	
		ARN11U975-AV			•						1			
		ARN11T976-AV		•		1	1	1	1	1		1	1	
		ARN11U976-AV		•							1			
17	LEAD WIRE A ASSY	ARN97T975-0U	S	•	•	1	1	1	1	1	1	1	1	
18	LEAD WIRE B ASSY	ARN98T975-0U	S	•	•	1	1	1	1	1	1	1	1	
19	PCB BASE ASSY	ARH01T975-0U	S	•	•	1		1	1	1			1	
		ARH01H975-0U	S	•	•		1							
		ARH01U975-0U	S	•	•						1			
		ARH01A975-0U	S	•	•							1		
20	PROTECTING FRAME COMPLETE	ARE20T975			•	1	1	1	1	1	1	1	1	
		ARE20T976		•		1	1	1	1	1	1	1	1	
21	HINGE EARTH LEAD WIRE	ARE46T962	S		•	1								
		ARE46H962	S		•		1	1	1	1	1		1	
		ARE46T976	S	•		1								
		ARE46S976	S	•			1	1	1	1	1		1	
22	THERMOSTAT ASSY	ARS10T975-0U	S		•	1								
		ARS10H975-0U	S		•		1	1	1	1			1	
		ARS10U975-0U	S		•						1			
		ARS10A975-0U	S		•							1		
		ARS10T976-0U	S	•		1								
		ARS10H976-0U	S	•			1	1	1	1			1	
		ARS10U976-0U	S	•							1			
23	OUTER SPRING	AQS61T2701		•	•	1	1	1	1	1	1	1	1	
24	NAME PLATE	ARY30T975-W9	S		•	1								



**Parts List**

REF. NO.	PART NAME	PART NO.	SAFETY	MODEL		COUNTRY / Q'TY							REMARK		
				MS103	MS183	TH	HK	PSV	SIN-RBD	SIN-DBD	TW	USA/CND		AU/NZ	
		ARY30H975-W9	S		•			1							
		ARY30V9751W9	S		•			1							
		ARY30Y975-W9	S		•				1						
		ARY30S975-W9	S		•					1					
		ARY30U975-W9	S		•						1				
		ARY30A9751W9	S		•							1			
		ARY30Z975-W9	S		•								1		
		ARY30T976-W9	S	•		1									
		ARY30H976-W9	S	•			1								
		ARY30V9761W9	S	•				1							
		ARY30Y976-W9	S	•					1						
		ARY30S976-W9	S	•						1					
		ARY30U976-W9	S	•							1				
		ARY30A9761W9	S	•								1			
		ARY30Z976-W9	S	•									1		
25	BODY	ARE10T975-W9			•	1	1	1	1	1	1		1		
		ARE10A975-W9			•							1			CHANGE MATERIAL TO PP NH601
		ARE10T976-W9		•		1	1	1	1	1	1		1		
		ARE10A976-W9		•								1			CHANGE MATERIAL TO PP NH601
26	FOOT RUBBER	ARH90E7221		•	•	2	2	2	2	2	2	2	2		
27	INLET	ARG10T92010U	S	•	•	1	1	1	1	1	1		1		
		ARF19T93410U	S	•	•							1			
28	INLET PLATE	ARF27T975-W9		•	•	1	1	1	1	1	1	1	1		
29	STEAMING BASKET	ARK53T975-W9		•	•	1		1	1	1	1	1	1		
		ARK53ED37WQU		•	•		1								
30	MEASURING CUP	ASR792-454BK		•	•	1	1	1	1	1	1	1	1		
31	RICE SCOOP	ARK02T975-W9		•	•	1	1	1	1	1	1		1		
32	POWER CORD ASSY (C-3)	ARQ00T959-0U	S	•	•	1									
	POWER CORD ASSY (SH-3)	ARQ00T920-0U	S	•	•			1	1						
	POWER CORD ASSY (S-3)	ARQ00M96110U	S	•	•		1								
	POWER CORD ASSY (S-3)	ARQ00S975-0U	S	•	•					1					
	POWER CORD ASSY (A-3)	AQQ00U526-0U	S	•	•						1				
	POWER CORD ASSY (A-2P)	ARQ00A97510U	S	•	•							1			
	POWER CORD ASSY (A-3)	ARQ00Z975-0U	S	•	•								1		
33	SIDE HEATER ASSY	ARL10T975-0U	S	•	•	1	1	1	1						
		ARL10S975-0U	S	•	•					1				1	
		ARL10U975-0U	S	•	•						1				
		ARL10A975-0U	S	•	•							1			
		ARL10T976-0U	S	•	•	1	1	1	1						
		ARL10S976-0U	S	•	•					1				1	
		ARL10U976-0U	S	•	•						1				
		ARL10A976-0U	S	•	•							1			

## Screws

REF. NO.	PART NAME	PART NO.	SAFETY	MODEL		COUNTRY / Q'TY							REMARK		
				MS103	MS183	TH	HK	PSV	SIN-RBD	SIN-DBD	TW	USA/CND		AU/NZ	
	TAPPING SCREW	XTB4+12GFJ		•	•	4	4	4	4	4	4	4	4	4	FIX BODY
	TAPPING SCREW	XTB4+12GFJ		•	•	3	3	3	3	3	3	3	3	3	FIX PCB BASE ASSY
	SEMS TAPPING SCREW	XYC4+CF8FJ		•	•	1	1	1	1	1	1			1	FIX EARTH CONNECTION
	TAPPING SCREW	XTN4+16AVW		•	•	1	1	1	1	1	1	1	1	1	FIX HINGE COVER
	TAPPING SCREW	XTB4+12GFJ		•	•	1	1	1	1	1	1	1	1	1	FIX INLET PLATE
	SEMS TAPPING SCREW	XYN4+C10FNS		•	•	1	1	1	1	1	1	1	1	1	FIX CAST HEATER ASSY
	SEMS SCREW	XYN4+C7FNS		•	•	2	2	2	2	2	2	2	2	2	FIX INTERNAL WIRING

## Packing List

REF. NO.	PART NAME	PART NO.	SAFETY	MODEL		COUNTRY / Q'TY							REMARK			
				MS103	MS183	TH	HK	PSV	SIN-RBD	SIN-DBD	TW	USA/CND		AU/NZ		
1	OPERATION INSTRUCTION	ARZ19T975	S	•	•	1									ENGLISH / THAI	
		ARZ19H975	S	•	•		1								ENGLISH / CHINESE	
		ARZ19V975	S	•	•			1	1						ENGLISH / VIETNAMESE	
		ARZ19S975	S	•	•					1					ENGLISH / CHINESE	
		ARZ19U9751	S	•	•						1				CHINESE	
	OPERATION INSTRUCTION A	ARZ19A975-A	S	•	•							1			ENGLISH / FRENCH / CHINESE	
	OPERATION INSTRUCTION B	ARZ19A975-B	S	•	•							1			KOREAN / SPANISH	
	OPERATION INSTRUCTION	ARZ19Z975	S	•	•								1		ENGLISH / CHINESE	
2	UPPER PAD ASSY	ARZ04T975-0U		•	•	1	1	1	1	1	1	1	1	1		
3	POLYETHYLENE SHEET	ASR762T929-K		•	•	1	1	1	1	1	1	1	1	1		
4	RUST PROOF PAPER	ASR758T344B		•	•	1	1	1	1	1	1	1	1	1		
5	LOW PAD ASSY	ARZ11T975-0U		•	•	1	1	1	1	1	1	1	1	1		
6	INNER PACKING CASE	ARZ01T975-W9	S		•	1										
		ARZ01H975-W9	S		•		1									
		ARZ01V975-W9	S		•			1								
		ARZ01Y975-W9	S		•				1							
		ARZ01S975-W9	S		•					1						
		ARZ01U975-W9	S		•						1					
		ARZ01A975-W9	S		•							1				
		ARZ01Z975-W9	S		•									1		
		ARZ01T976-W9	S	•			1									
		ARZ01H976-W9	S	•				1								
		ARZ01V976-W9	S	•					1							
		ARZ01Y976-W9	S	•						1						
		ARZ01S976-W9	S	•							1					
		ARZ01U976-W9	S	•								1				
ARZ01A976-W9	S	•									1					
ARZ01Z976-W9	S	•											1			
7	MENU BOOK	ARZ20T9751		•	•	1		1	1						THAI / ENGLISH / VIETNAMESE	
		ARZ20S9751		•	•		1			1	1	1			ENGLISH / CHINESE (KH) / CHINESE (TW)	
		ARZ20A975		•	•							1			FRENCH / KOREAN / SPANISH	
		ARZ20Z975		•	•									1		ENGLISH / CHINESE

## DETAIL CHANGE NOTICE

REVISION	ITEM NO.	PAGE	DETAIL	REMARK
MAR. 2011	1	1	REVISE ADD. REVISION AND DESTINATION	ADD. COUNTRIES FOR SALES AS TW, USA/CND, PANAMA AND AU/NZ
	2	4	REVISE SPEC.	ADD. DATA OF NEW COUNTRIES
	3	19	CUTTING INLET CASE BUT ADD. FOOT RUBBER IN EXPLODE VIEW NO. 26	REVISE PARTS TO USE ASSEMBLY
	4	21 - 26	ADD. COUNTRIES & PART LIST	ADD. COUNTRIES AND PART LIST FOR TW, USA/CND, PANAMA AND AU/NZ
	5	22, 25	ADD. PART NO. OF STEAMING BASKET	REVISE FOR HONG KONG MODEL ONLY
	6	26	REVISE PART NO. OF OPERATION INSTRUCTION	PRODUCT NAME IS WRONG