

Service Manual

Drum Type Washing Machine

Model No. **NA-128VB6WAE**

Model No. **NA-128VB6WPG**

Product Colour : White

Destination : United Arab Emirates (UAE), Iran, Libya



⚠ WARNING

This service information is designed for experienced repair technicians only and is not designed for use by the general public. It does not contain warnings or cautions to advise non-technical individuals of potential dangers in attempting to service a product. Products powered by electricity should be serviced or repaired only by experienced professional technicians. Any attempt to service or repair the product or products dealt with in this service information by anyone else could result in serious injury or death.

IMPORTANT SAFETY NOTICE

There are special components used in this equipment which are important for safety. These parts are marked by **⚠** in the Schematic Diagrams, Circuit Board Diagrams, Exploded Views and Replacement Parts List. It is essential that these critical parts should be replaced with manufacturer's specified parts to prevent shock, fire or other hazards. Do not modify the original design without permission of manufacturer.

TABLE OF CONTENTS

	PAGE	PAGE
1 Safety Precautions -----	2	
2 Specifications -----	3	
3 Location of Controls and Components -----	5	
4 Installation Instructions -----	6	
5 Operating Instructions -----	8	
6 Test Mode -----	10	
7 Service Mode -----	12	
8 Troubleshooting Guide -----	14	
9 Critical Torque Values -----	15	
10 Disassembly and Assembly Instructions -----	16	
11 Component Specifications -----	33	
12 Wiring Connection Diagram -----	42	
13 Exploded View and Replacement Parts List -----	44	



Panasonic

© Panasonic Corporation 2015 Unauthorized copying and distribution is a violation of law.



1 Safety Precautions

In order to prevent any accident during repair work and ensure security of the product after repair work, somethings surely followed are explained below.

■The level of the arised damages or dangers, when indicated contents are ignored, are classified by following indications and explained.

	Warning The content in the column of this indication is "Be assumed that possibly die or get seriously injured".
	Attention The content in the column of this indication is "Be assumed that possibly get damages or possibly only damaged object occurred".

■Types of the contents being followed are classified by following figured symbols and explained.
(The following is an example of expression in pictures.)

	This figured symbol means caution " Attention ".
	This figured symbol means must not do " Prohibition ".
	This figured symbol means surely execute " Instructions ".

Warning

Connection of cables should be done according to regular work.



- Connection of cables should be tightened reliably with strength using solderless terminal. (specified parts always using regular bonding plier)
- Install a fire protection cover (fireproof) covering connection area completely, and close opening area by tape. (Please reuse the fire protection cover which came with the product.)
- When drawing cables around, fixing those cables with cable suppression part. Do not touch rotating part, high temperature part and surface of metal.
- Be sure to replace with cable unit when any cable was snapped. When a part of the cable unit was cut you must not do the connection repair. It may be the cause of smoke, ignition or receiving an electric shock.

Be careful about receiving an electric shock.



When doing electric connection service such as voltage measurement, please be careful enough about receiving an electric shock at electric charging parts and cable terminal parts.

Pull out electric plug when doing repair work.



Disassembling, assembling and replacing parts should be done after pulling out electric plug. Receiving an electric shock or getting an injury may occur.

Be sure to use specified parts.



Always use specified parts for the parts with mark  in the electric circuit diagrams and parts list. It may be the cause of smoke, ignition or damage.

Do not touch any rotating object with hand unless it stops completely.



Slow rotation may also roll in your hands and cause injury.

Rebuilding is prohibited.



Do not rebuild machine parts and components when repairing service. It may be the cause of damage or ignition.

Straightly pull out or insert in huasuton terminal.



Do not twist it. It may be the cause of damage or ignition.

Attention

Please wear gloves when disassembling, replacing and assembling.



Always wear gloves to prevent an injury by the metal end face or an electric shock at the time of the electricity service.

Please be careful to the edges of the metal end face.



Wear the working clothes of long sleeves to prevent an injury by the metal end face or please work after covering the end face with tape or towel.

2 Specifications





2.1. Product Specifications

Model		NA-128VB6
Product Type		Front Loader
Capacity		8 kg
Max Spin Speed		1200 rpm
Drum Volume		55 lt
Energy Label Rating		A+++
Energy Consumption		194 kWh / annum
Water Consumption		9900 L/annum
Noise Level	Wash	58 dBA
	Spin	74 dBA
Control Panel		LCD Display
Wash Programs		15 settings
Spin Speed Setting		7 setting
Dimensions	Height	84.5 cm
	Width	59.7 cm
	Depth	55.7 cm
Door Opening		Large door opening
Delay Time Setting		Yes
Colour		White
Water Protection		Overflow Protection
Other Features		Child Lock
Packaging		Shrink package

2.2. Name Plate

Panasonic

Ser. No. 380001

Model No. NA-128VB6	BASIC TYPE NO: PB1255CAL
220-240V ~ 50Hz	Panasonic Corporation
 1200/min	Made in Turkey
P 2200W	Fabriqu� en Turquie
	
	IPX4



2.3. Dimension

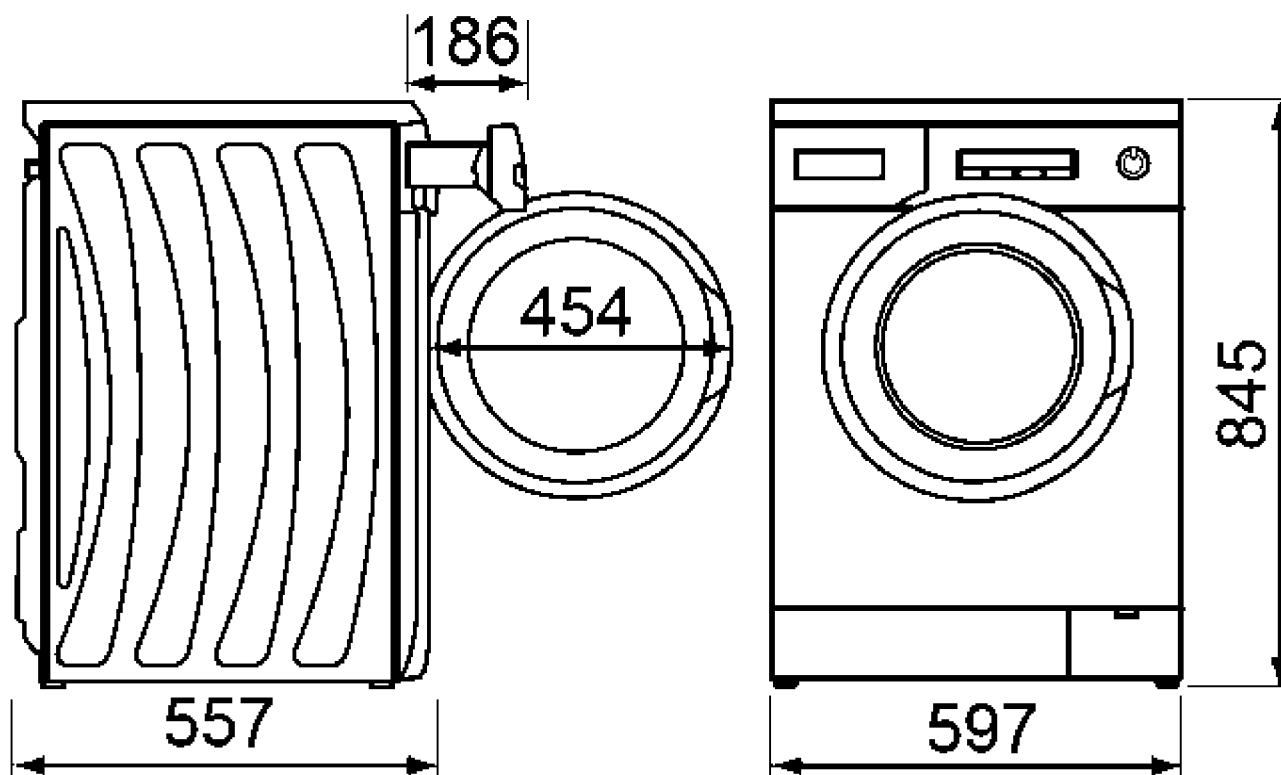

Dimension in millimetres
NA-128VB6

3 Location of Controls and Components

Your washing machine

Detergent drawer

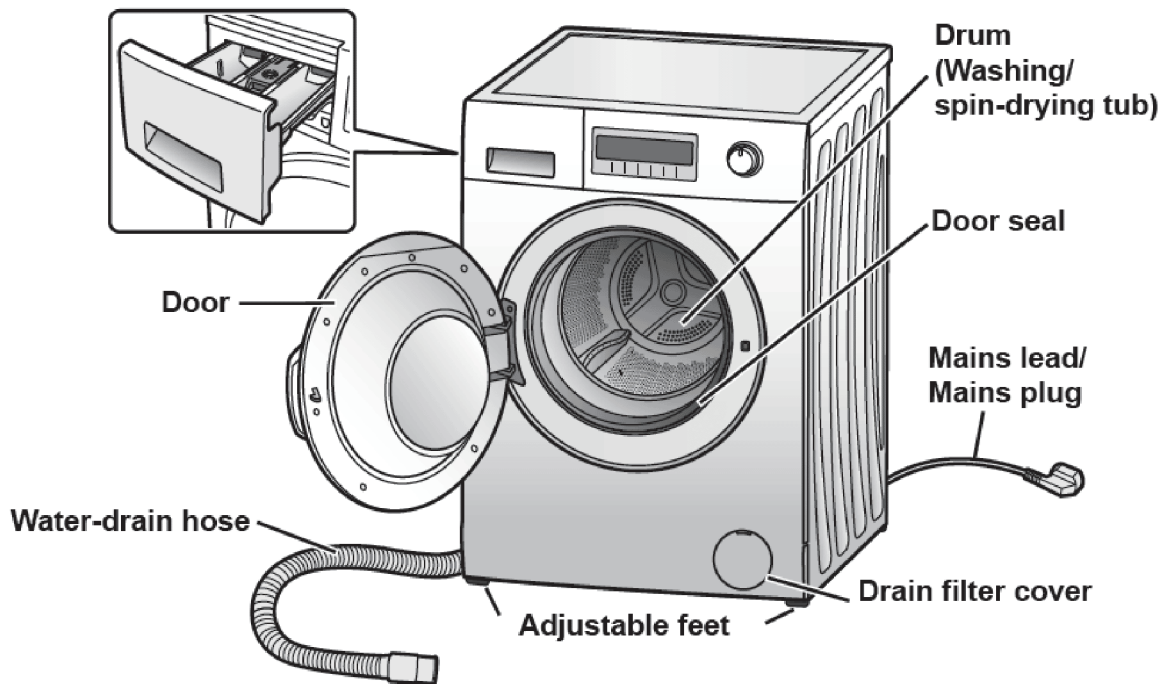

Accessories

Make sure that all the accessories are supplied with the appliance.

Elbow

For fixing the water-drain hose



Liquid detergent level plate



Cover cap (x4)



Water-supply hose

Either one of these hoses is supplied with the appliance.



4 Installation Instructions

4.1. Moving and Installing

4.1.1. Removal of Transportation Screw

1. Transportation screws, which are located at the back side of the machine, must be removed before running the machine.
2. Loosen the screws by turning them anticlockwise with a suitable spanner.

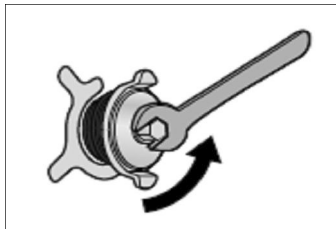

3. Pull out the screws and rubber washers.

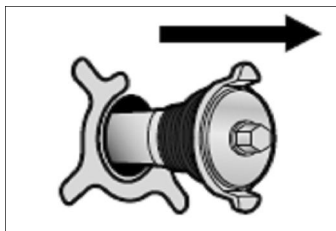

4. The holes where the transport screws have been removed should be covered with the plastic transport caps found in the accessories bag.
5. The transportation screws that have been removed from the machine must be re-used in any future transporting of the machine.

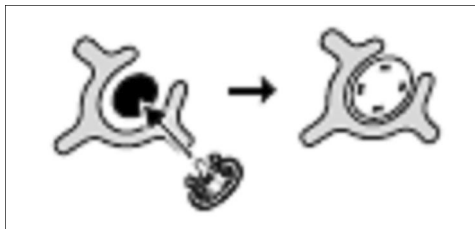

4.1.2. Foot Adjustment

1. Do not install machine on rugs or similar surfaces.
2. For machine to work silently and without any vibration, it should be installed on a flat, non-slippery firm surface. Any suspended floor must be suitably strengthened.
3. You can adjust the level of machine using its feet.
4. First, loosen the plastic adjustment nut away from the cabinet base.
5. Change the level by adjusting the feet upwards or downwards.
6. After level has been reached, tighten the plastic adjustment nut again by rotating it upwards against the base of the cabinet.
7. Never put cartons, wooden blocks or similar materials under the machine to balance irregularities of the floor.

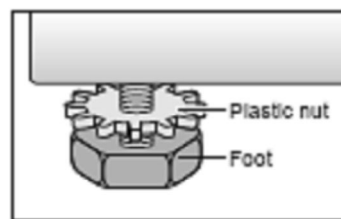

4.1.3. Electrical Connection

1. Washing machine requires a 50Hz supply of 220-240Volts.
2. A special earthed plug has been attached to the supply cord of washing machine. This plug must be fitted to an earthed socket. The fuse value fitted to this plug should be 13 amps. If you have any doubts about electrical supply, consult a qualified electrician.

THIS APPLIANCE MUST BE EARTHED.
Insert the machine's plug to a grounded socket which you can easily reach.

4.1.4. Water Supply Connection

1. Washing machine is supplied with a single (cold) water inlet.
2. To prevent leakage from the connection joints, a rubber washer is included in the hose packing. Fit this washer at the end of water inlet hose on the tap side.
3. Connect the hose to the water inlet valve. Tighten the plastic connector by hand. Please call a qualified plumber if you are unsure about this.
4. Water pressure of 0,1-1 MPa from tap will enable machine to work more efficiently. (0,1 MPa pressure means water flow of more than 8 litres in 1 minute from a fully opened tap)
5. After connection is complete, check for leakage by turning on tap completely.
6. Make sure that water inlet hoses can not become folded, damaged, stretched or crushed when the washing machine is in its final position.
7. Mount the water inlet hose to a $\frac{3}{4}$ " threaded water tap.

4.1.5. Drain Connection

1. Make sure that water inlet hoses are not folded, twisted, crushed or stretched.
2. The drain hose should be mounted at a minimum height of 60 cm, and a maximum height of 100 cm from the floor.
3. The end of the drain hose can be connected directly to a drainage stand-pipe or alternatively to a specific connection point designed for that purpose on the waste outlet of a sink unit.
4. Do not extend the drain hose or guarantee will be invalidated.

4.2. Detergent Box Group

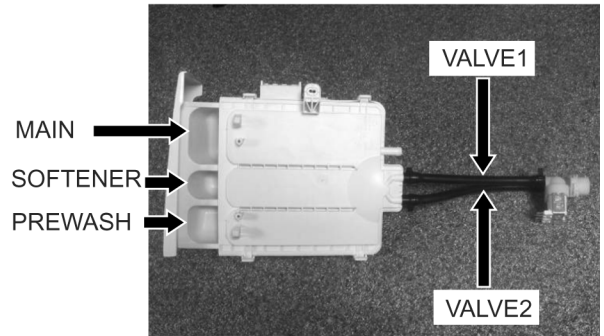

PREWASH = WATER ENTRY VALVE 1
MAIN = WATER ENTRY VALVE 2
SOFTENER = WATER ENTRY VALVE 1 + VALVE 2

5 Operating Instructions

5.1. LCD Screen, Function Buttons & Knobs

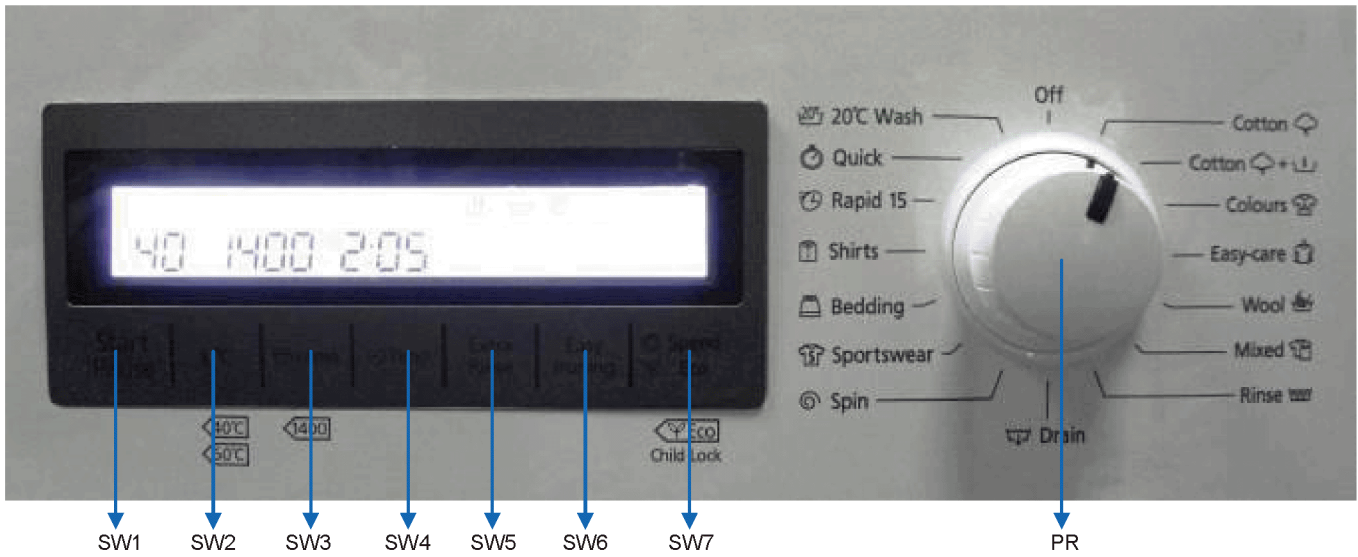



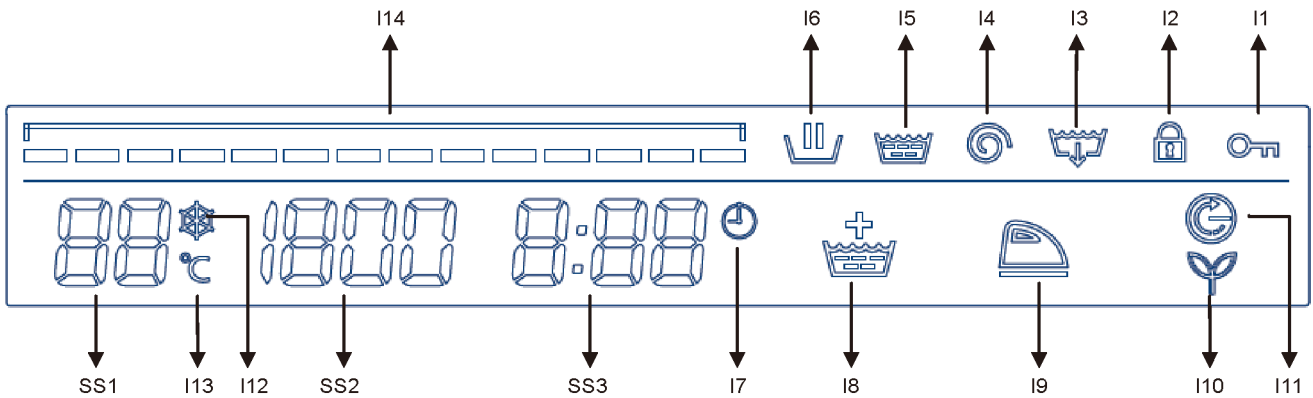









PR	Program selector 16 programs including off position
SW1	Switch 1, Start / Pause
SW2	Switch 2, Temperature Selection
SW3	Switch 3, Spin Speed Selection
SW4	Switch 4, Delay Timer Selection
SW5	Switch 5, Extra Rinse Option
SW6	Switch 6, Easy Ironing Option
SW7	Switch 7, Eco/Speed Mode Option



SS1	7 Segment LCD for Temperature Display	I8	Extra Rinse Symbol
SS2	7 Segment LCD for Spin Speed Display	I9	Easy Ironing Symbol
SS3	7 Segment LCD for Remaining Time	I10	Eco Mode Symbol
I1	Child Lock Symbol	I11	Speed Mode Symbol
I2	Door Lock Symbol	I12	Cold Wash Symbol
I3	Drain Phase Symbol	I13	Temperature Sign
I4	Spin Phase Symbol	I14	Program Proceeding Zone
I5	Rinse Phase Symbol	Slow Blink	ON 0.5 sec, OFF 0.5 sec, ON 0.5 sec
I6	Wash Phase Symbol	Fast Blink	ON 0.10 sec, OFF 0.10 sec, ON 0.10 se
I7	Delay Symbol		

5.2. Program Details

Power and Water Consumption

Programme	Temperature	Load (kg)	Power consumption (kWh) ¹⁾	Water consumption (L) ²⁾	Time ²⁾
			148V/6 128V/6	148V/6 128V/6	148V/6 128V/6
 Cotton	40 °C	8	0.92	60	2:05
 Cotton + Eco function	40 °C ¹⁾	4	0.71	41	2:50
	60 °C ¹⁾	8	0.95	51	3:20
		4	0.77	41	2:55
 Cotton (Prewash)	40 °C	8	0.98	70	2:23
 Colours	40 °C	4	0.91	52	1:45
 Easy-care	40 °C	4	0.60	55	1:25
 Hand Wash	30 °C	2	0.32	68	1:30
 Allergy-care	60 °C	4	3.08	87	3:20
 Wool	30 °C	2	0.10	50	0:40
 Shirts	40 °C	2	0.60	45	1:25
 Mixed	30 °C	3.5	0.46	55	1:25
 Quick	40 °C	4	0.48	38	1:08
 Rapid 15	30 °C	2	0.10	30	0:15
 20°C Wash	20 °C	4	0.31	42	1:40

1) Results calculated based on the maximum spin speed comply with EN 60456.

2) The power, water consumption, and time indicated in the table may vary depending on variations in pressures, water hardness and temperatures, room temperatures, types and amounts of laundry, voltage fluctuations and functions to be used.

5.3. Child Lock

Activation

1. Press SW7 for 5 seconds.



2. The Child Lock Symbol on appears on the LCD display as Child Lock is active.



Deactivation

1. Press SW7 for 5 seconds.

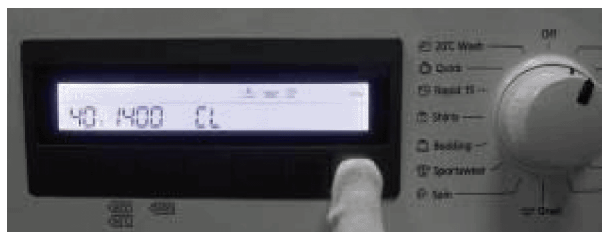

2. The Child Lock Symbol will disappear on LCD display upon deactivation.



6 Test Mode

6.1. Autotest

1. Set PR to program 3 (Colours)



2. While pressing SW5 (Extra Rinse), change position of the PR from third program to second (Cotton-Prewash), and release SW5.



3. Autotest starts.



AUTOTEST													
	5	10	15	20	25	30	35	40	45	50	55	60	65
Time in seconds (to be adjusted)													
Entering autotest													
Changing power to 220 50Hz													
Main Voltage 50 Hz													
Door Lock Powered (Depends on door lock)													
Motor Ramp to max spin (max. is 15 sec.)													
Time until motor is stopped (Depends on the motor stop time)													
Motor Preferred Run (Direction to Right)													
Motor Inverse Run (Direction to Left)													
EV1 (flowrate dependent of washer)													
EV2 (flowrate dependent of washer)													
Test stopped until E.Rinse button is pressed (symbol blinking)													
EV1 + EV2 valves up to autotest level frequency (Depends on the water level)													
NTC check													
Heather resistance													
Pump													
EPS measurement													
End Visualization													

Ntc detection Software will detect NTC's resistance value and will check if the temperature is between 5°C < Tdetected < 40°C. If it is inside the range, heating step will be done.

If temperature value is outside the range, then it means NTC is detecting the temperature in a wrong way and heating step will be skipped.

EPS measurement: The frequency value should be between 46.04Hz - 43.40Hz. It checks the EPS and if it OK, it continues the autotest, if it is NOK then cancel the Autotest and go to the selection mode. Also if any frequency can not be detected, then it mean

7 Service Mode

7.1. Service Autotest

1. Set PR to program 3 (Colours) and press SW2 (T°C)



2. While pressing the SW2, change PR position from third to second, and release the SW2 button.



3. Bring PR to desired test step (1st ,2nd or 3rd program position) as soon as "SAU" is displayed on LCD.



LCD Display status:

I2 Door Lock Symbol → Fixed on

SS3 → SAU

	Step1	Step2	Step3
	PR Position: Program 1 (Cotton)	PR Position: Program 2 (Cotton Prewash)	PR Position: Program 3 (Colours)
	Result	Result	Result
	HEATER ON	PUMP ON	TEST PROGRAM ON (Rapid 12')
Comments :	When entering in service test, door will be locked.		Test is over Door will be unlocked, machine will go to END state.

The test steps are as below ;

Step 1 :

- Selector Program 1 (Cotton) will be "HEATER ON"
- Before heating it should take water till first level frequency then start heating.
- Heater will be on max. 8 minutes after this 8 minutes if the temp. doesn't change more than 2 °C then it will give NTC failure. (E05).
- Or if the NTC connection is broken then it should give again E05 NTC failure.
- At the end of heating, "SAU" visualization should make slow blink to indicate that the step is over.
- Note : If user changes the selector position, machine will do what is defined for the new selected position.

Step 2 :

- Selector Program 2 (Cotton Prewash) will be "PUMP ON"
- Temperature will be measured, if it is higher than 50 °C, it should take 60 sec. cooling water, and then make "Drain + 5 sec."
- At the end of pump activation, "SAU" visualization should make slow blink to indicate that the step is over.

Step 3 :

- Selector position 3 (Colours) will be a 12 mins test program where all functions of the appliance will be checked.
- Machine will make exactly the same algorithm of Super Rapid 12'.
So, time for selector position 3 is 12 minutes.
- At the end of test program "End" is visualized on LCD and door is unlocked.

7.2. Failure Codes

Error Indication	Error Number	Indication For User	Indication For Service
		Yes/No	Yes/No
Door is not locked	E01	Yes	Yes
Door is unlocked during programme	E01	Yes	Yes
Lack of water	E02	Yes	Yes
Pump failure	E03	Yes	Yes
Overflow	E04	Yes	Yes
NTC or Heater Failure	E05	No	Yes
Motor Failure - 1 (Tachometer open-short circuit or motor connector is disconnected)	E06	No	Yes
Motor Failure - 2 (triac short circuit)	E08	No	Yes
Electronic Pressure Sensor	E10	No	Yes

8 Troubleshooting Guide

All repairs which must be done on the machine should be done by authorized agents only. When a repair is required for machine or you are unable to eliminate the failure with the help of the information given below:

- Unplug the machine.
- Close the water tap.

FAILURE	PROBABLE CAUSE	METHODS OF ELIMINATION
Machine does not operate.	It is unplugged.	Insert the plug into the socket.
	Fuse is defective.	Change fuse.
	Start / Pause button has not been pressed.	Press the start / pause button.
	The program knob is in 0 (off) status.	Bring the program knob on the desired status.
	The door is not shut properly.	Shut the door properly. You should hear the click.
Machine does not receive water.	Child lock is active.	See section 5.3.
	Water tap is closed.	Open water tap.
	The water inlet hose may be bent.	Check the water inlet hose.
	The water inlet hose is obstructed.	Clean the filters of water inlet hose.
	The water inlet filter is obstructed.	Clean the valve inlet filters.
Machine is not draining water.	The door is not shut properly.	Shut the door properly. You should hear the click.
	The drain hose is obstructed or bent.	Check the drain hose.
	The pump filter is obstructed.	Clean the pump filter.
Machine is vibrating.	The clothes are not placed inside the machine in a well-balanced manner.	Spread the clothes inside the machine in an orderly and well-balanced manner.
	The feet of machine are not adjusted.	Adjust the feet.
	Transportation screws are not removed.	Remove transportation screws.
	There is a small amount of clothes in the device.	It does not prevent operation of the machine.
Excessive foam in the detergent drawer.	Excessive amount of clothes are filled in the machine or the clothes are not placed in a well-balanced manner.	Do not exceed the recommended quantity of clothes and spared clothes in the machine in a well-balanced manner.
	Too much detergent has been used.	Press the start/pause button. In order to stop the foam, dilute one table-spoon of softener in half liter of water and pour it in the detergent drawer. Press the start/pause button after 5-10 minutes. Arrange the amount of the detergent properly in the next washing process.
The washing result is bad.	Wrong detergent has been used.	Use only the detergents produced for full automatic machines.
	Laundry too dirty for the program you have selected.	Select a suitable program.
The washing result is not good.	The amount of detergent used is not sufficient.	Use more detergent according to the detergent.
	Clothes exceeding the maximum capacity has been filled in machine.	Put the clothes in machine in a manner not to exceed its maximum capacity.
	Water may be hard.	Use the amount of detergent according to the declaration of the detergent producer.
The water is seen in the drum during washing.	Distribution of the clothes in machine is not well-balanced.	Spread the clothes inside the machine in an orderly and well-balanced manner.
	No failure. The water is at the lower part of the drum.	
There are residues of detergent on the clothes.	The pieces of some detergents which do not dissolve in water may stick to clothes as white stains.	By calibrating machine for "Rinsing" program, make an additional rinsing or eliminate the stains After drying with the help of a brush.
There are grey stains on the clothes.	These stains may be caused by oil, cream or ointment.	In the next washing operation, use the maximum detergent amount declared by the detergent producer.
The spinning process is not done or starts with delay.	No failure. The unbalanced load control works in that way.	The unbalanced load control system will try to distribute clothes in a homogenous manner. After clothes are distributed, passage to spinning process will be realized. In the next washing process, place clothes into the machine in a well-balanced manner.

9 Critical Torque Values

	ASSEMBLY LOCATION	BOLT/NUT	TORQUE MIN. (Nm)	TORQUE NOM. (Nm)	TORQUE MAX. (Nm)	Air Pressure Wrench (rpm)
*	Transport Screw Assembly	Transport Screws	6.50	6.50	7.00	1000
*	Motor Assembly	Motor Screws	6.00	6.50	7.50	800
*	Front Concrete Weight - Front Tub Assembly	Front Counterweight Screws	14.00	14.50	14.75	600
*	Upper Counter Weight Assembly	Upper Counter Weight Screws	25.00	27.50	30.00	440
*	Pulley - Drive Shaft - Washing Group Assembly	Pulley – Drive Shaft Assembly Bolt	39.50	40.00	40.50	440
*	Heater Assembly	Heater Assembly Nut	3.85	4.00	4.00	970

The bolts/nuts above are important for product safety purposes. Please tighten screw, bolts and nuts according to the torque values given in table above.

10 Disassembly and Assembly Instructions

10.1. Top Plate

1. Remove two screws that fix the top-plate at the back.



2. Push the top-plate back and pull it up.

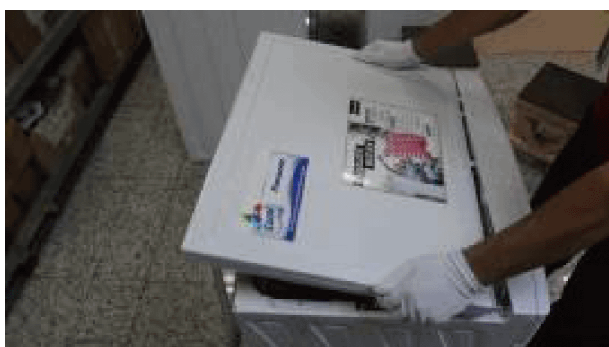

10.2. Door

1. Remove two screws that fix the door. (by using T25 tool)

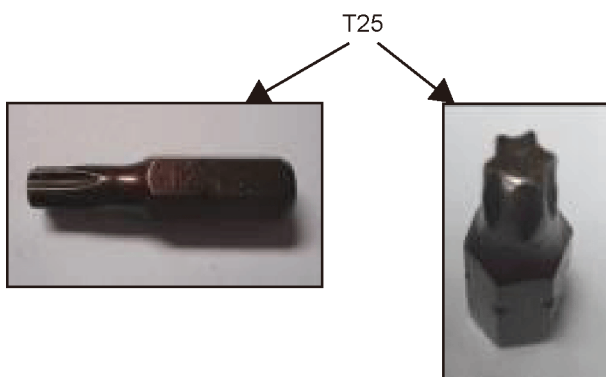

2. Pull the door up.



3. Remove screws that fix the door group.



4. Put the door outside plastic with helping screwdriver.

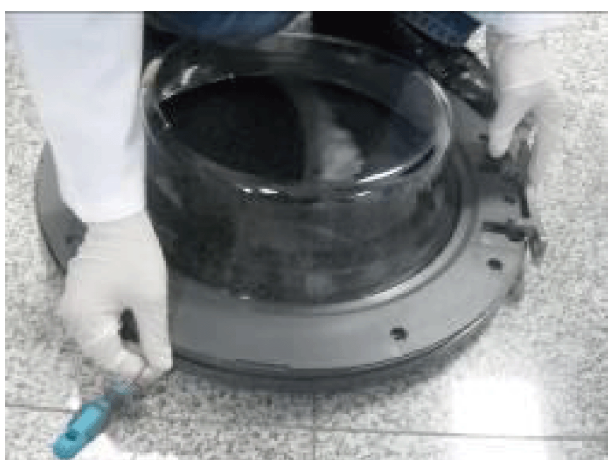

5. Remove the door inside plastic.



6. Remove six screws that fix the door hinge.



7. Remove the door handle.



8. Remove the door handle pin.

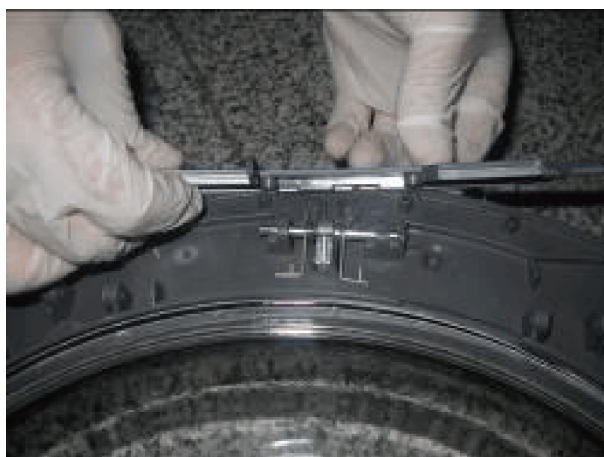

10.3. Spring Wire

1. First remove the spring wire fixing the tub bellows seal by using the small size screwdriver.
Pull the tub bellows seal.



2. Remove the tub bellows seal-body fixing spring.



10.4. Detergent Drawer

1. Gently pull the detergent drawer.



2. While pressing siphon cover keep pulling drawer to remove it.



10.5. Control Panel

1. Remove the screw which fixes the control panel to the front panel.



2. Remove two screws fixing control panel.

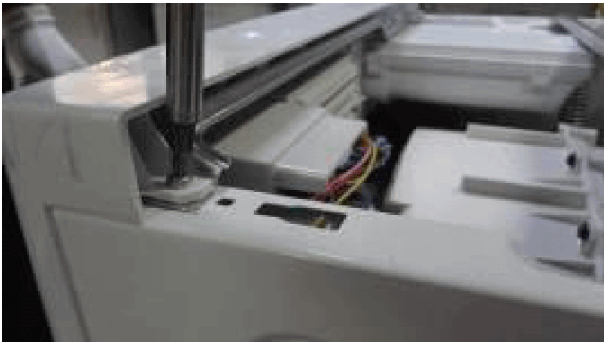

3. Pull the control panel out.



10.6. Electronic Card

1. Depress the taps fixing the card by using a screwdriver.

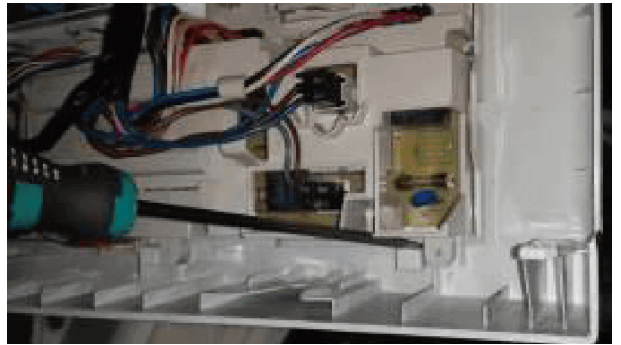

2. Release the socket fixing plastic by depressing the taps with the help of a screwdriver.



3. Remove the card out off panel.

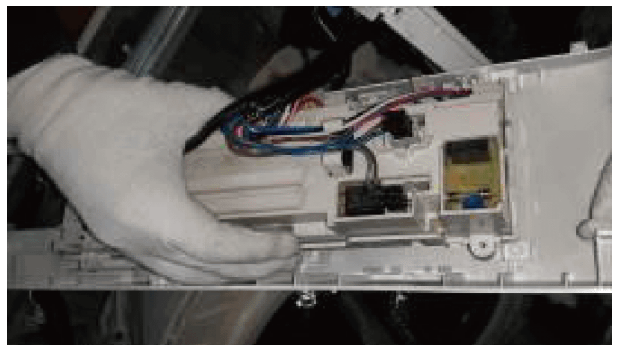

4. Remove the sockets on the card.

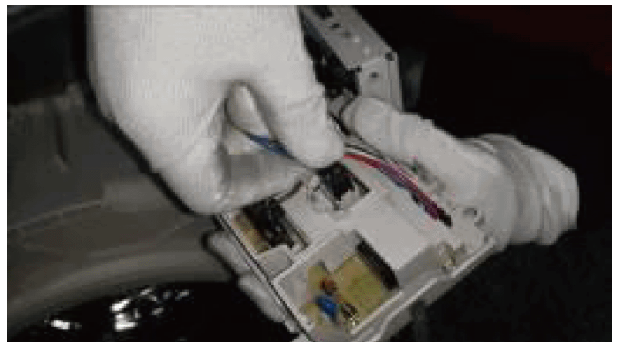

5. After releasing sockets, remove PCB box from its housing around the box.



6. Disassemble the PCB box and its cover.

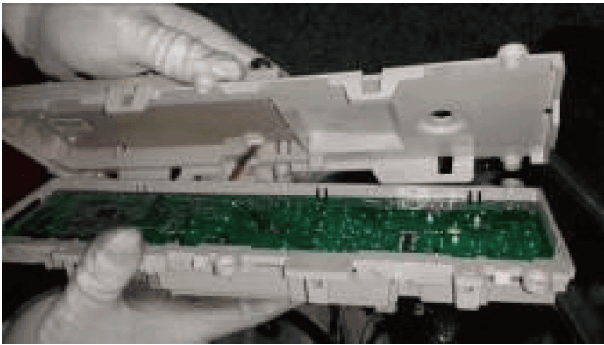

7. Remove the PCB card by depressing the tabs that fix it.

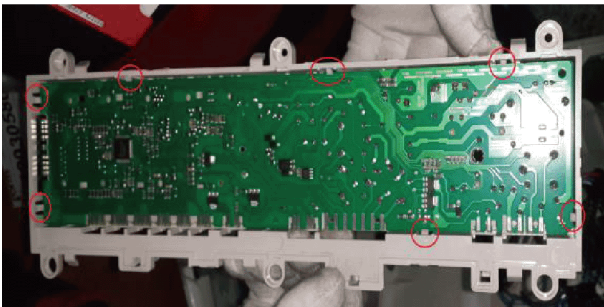

8. Remove the connector that fix the LCD screen.

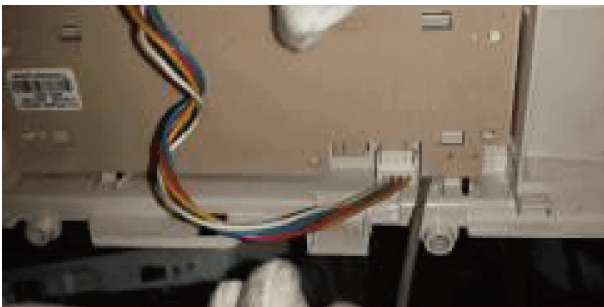

9. Remove the card from its housing and unplug its connector.

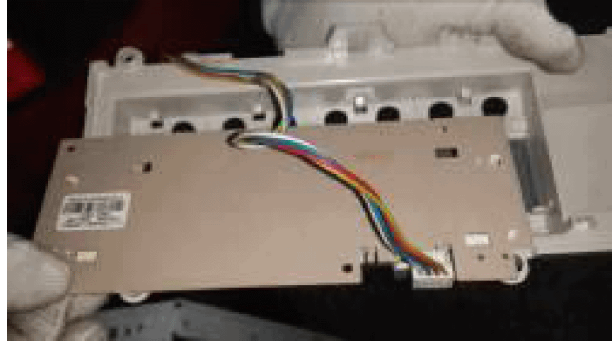

10. Remove the LCD screen by depressing the tabs by using a screwdriver.

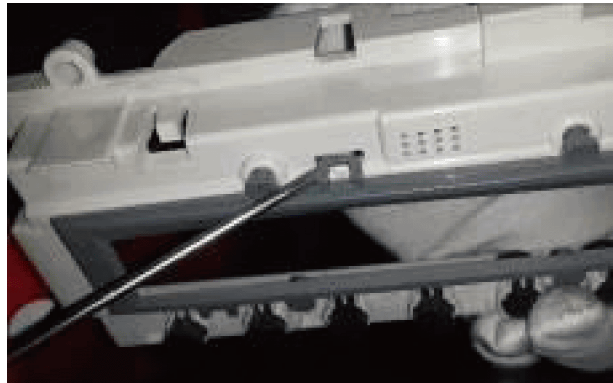

10.7. Front Panel

1. Remove the screw fixing the front panel at the bottom.



2. Remove two screws fixing the door lock.



3.



4. Remove the tub bellows seal.



5. Remove two screws fixing front panel to body.

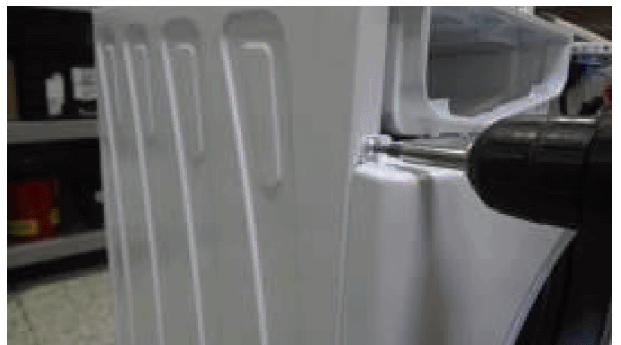

6. Remove the screw fixing twinjet elbow.



7. Pull front panel up.



8. Remove front panel.

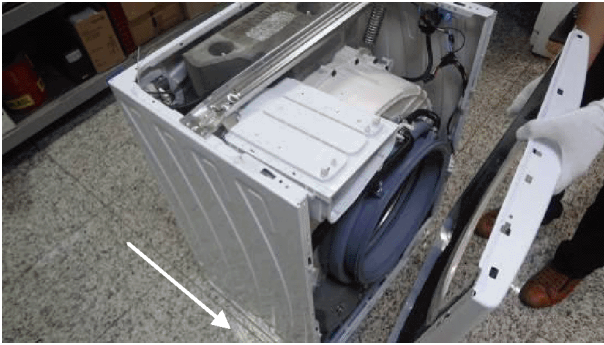

10.8. Support Bracket

1. Remove two clips fixing detergent drawer housing to upper support bracket.

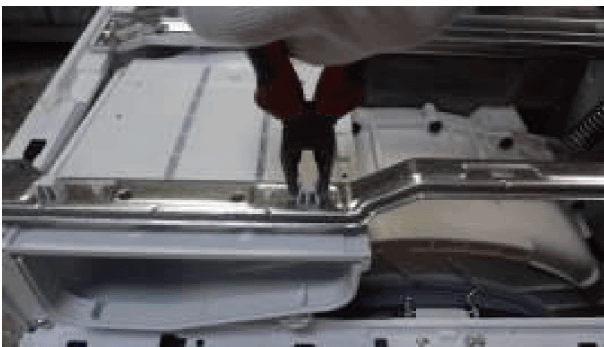

10.9. Detergent Drawer Housing

1. Remove the tub bellow hose by releasing the holder extensions of bellow hose.



2. Unplug connectors from feed valve.



3. Slightly turn the feed valve counter-clockwise to remove.

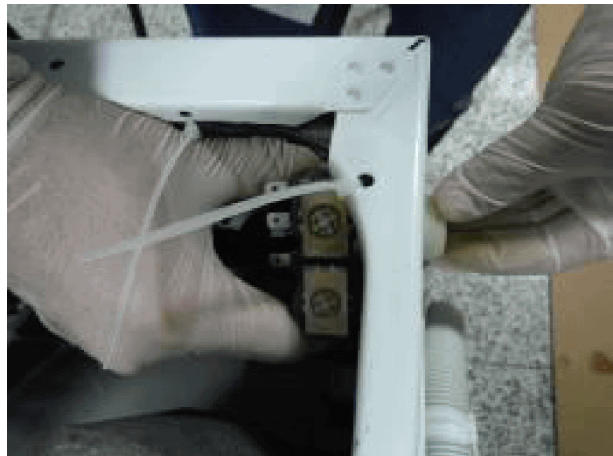

4. Remove the detergent drawer housing assembly.



10.10. Power Cable Group and EMI Filter

1. Remove the five connectors that is connected to the EMI filter.



2. Remove two screws fixing the EMI filter.



3. Pull the power cable group up.

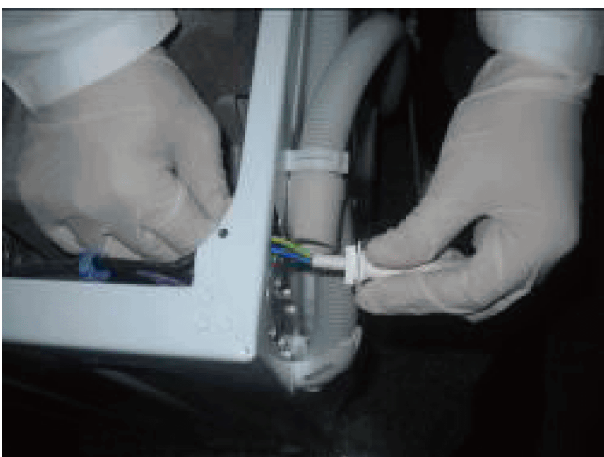

4. Remove EMI filter.

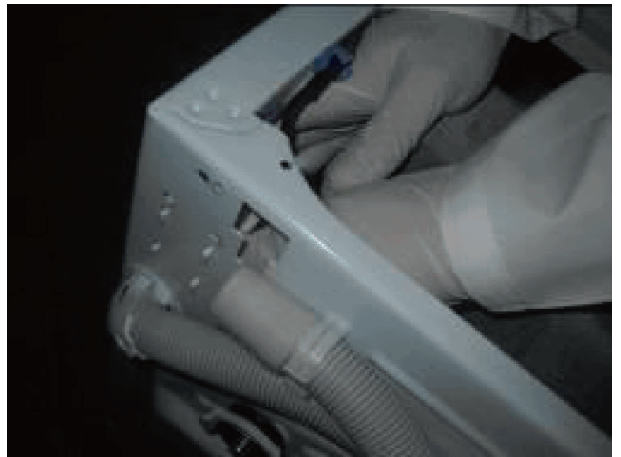

10.11. Electronic Pressure Switch (EPS)

1. Unplug EPS connector.



2. Pull EPS up.

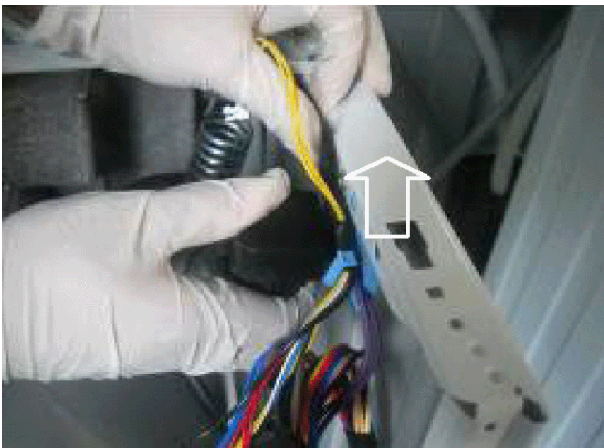

3. Remove clamp from EPS hose.



10.12. Door Lock

1. Unplug door lock connector.



10.13. DC CARD

1. Remove the bolts that fix DC card by using a screwdriver(T25).

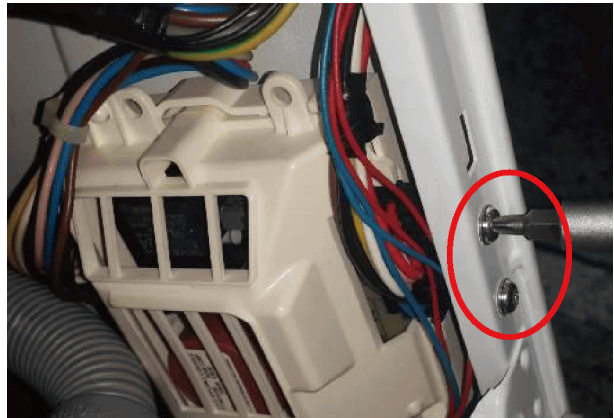

2. Remove the card after releasing it from its connector.

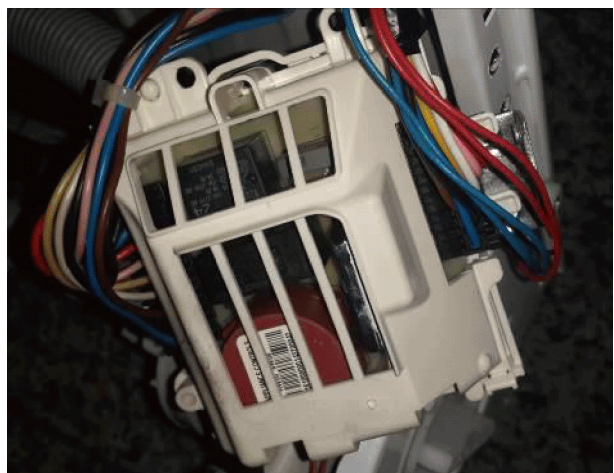

10.14. Drain Pump

1. Remove clamp holding drain hose by using a plier.



2. Remove clamp fixing tub outlet hose.



3. Unplug drain pump connector.



4. Remove screws holding drain pump.

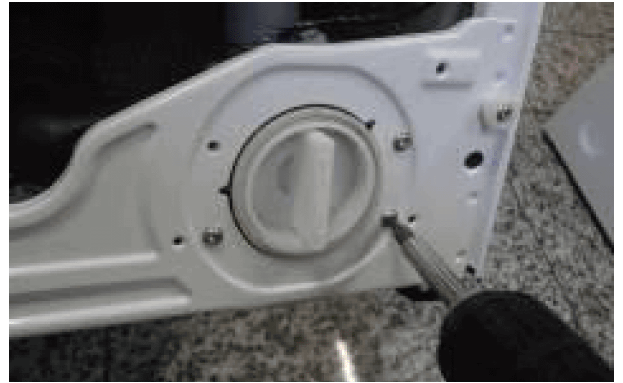

10.15. Front Counterweight

1. Remove three screws on the front counterweight.
(Wrench size 13 mm)



2. Gently pull counterweight out.



10.16. Heater

1. Unplug heater connectors.



2. Remove nut (8 mm) fixing the heater.



3. Pull heater out gently holding both sides.

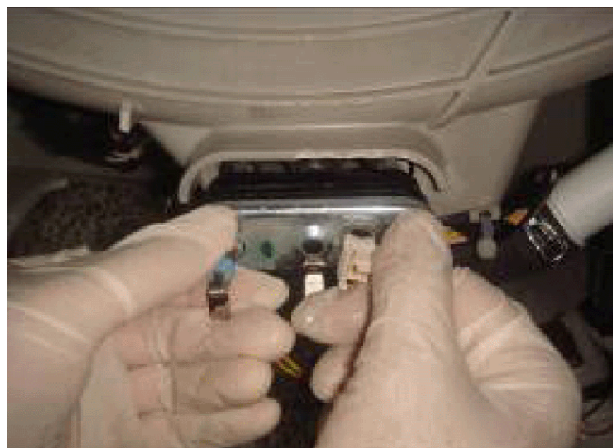

10.17. Twinjet System

1. Remove twinjet hoses from tub bellow seal pulling them up.

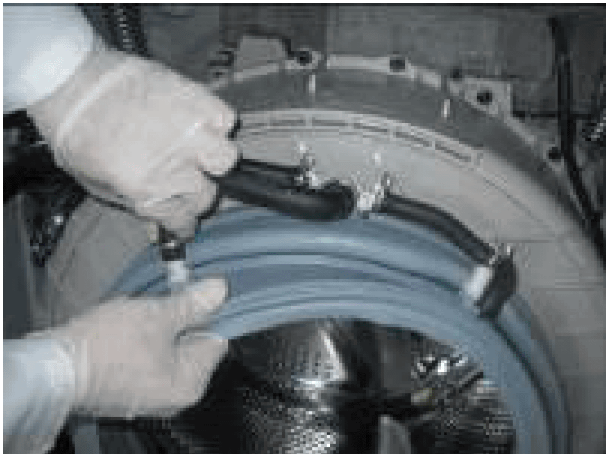

2. Remove screw fixing circulation pump.

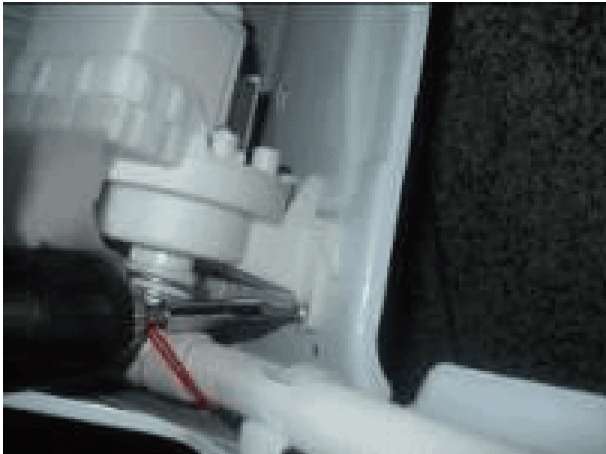

3. Lay the appliance down and press on ratchet holding circulation pump.

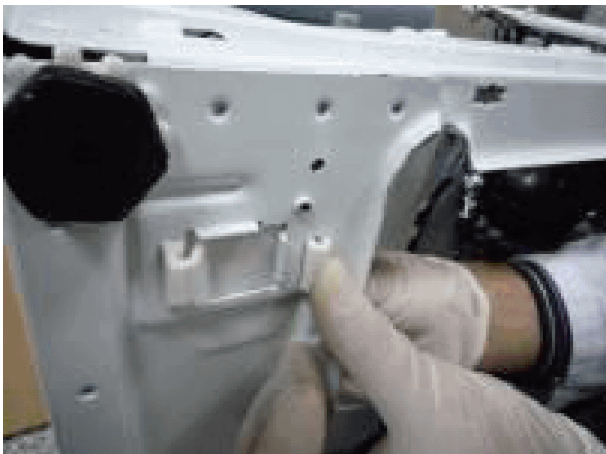

4. Remove circulation pump.

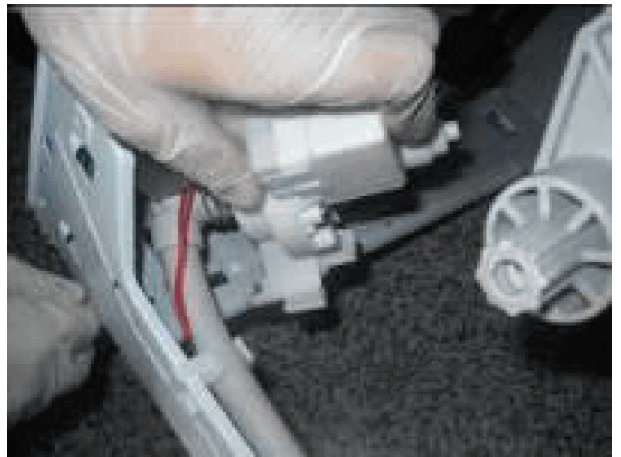

5. Remove cable connector.



6. Remove hose connecting circulation pump to drain pump.



10.18. Tub Bellow Seal

1. Remove the tub gasket clip by using small screwdriver.

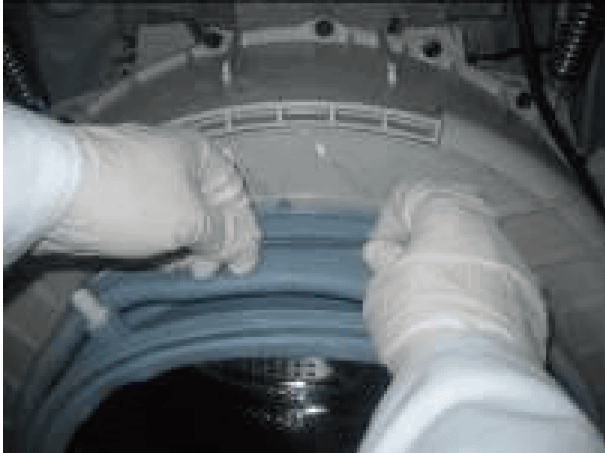

2. Hold the tub bellows seal and gasket-body fixing spring together, and pull them out.



10.19. Transport Screw

1. Remove four transport screws.



2. Hold the transport screw and pull it out.



10.20. Upper Counterweight

1. Remove two screws fixing the upper counterweight by using box wrench size 13 mm.



2. Hold and carry upper-counterweight out.



10.21. Washing Group

1. Unplug motor connectors.

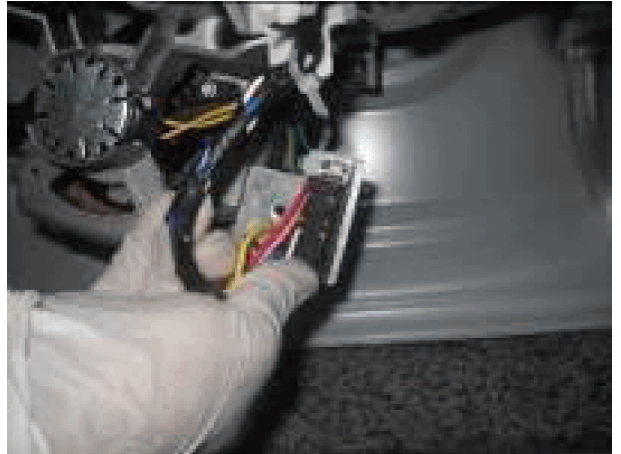

2. Cut all the cable ties which fix cable group.

a)



b)



c)

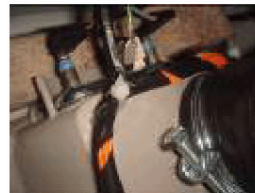

d)

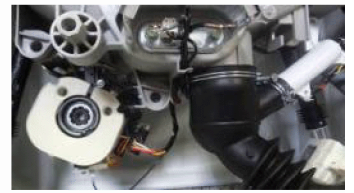

3. Remove the screws fixing hanger bracket.



4. Remove the washing group carrying it out through front side.

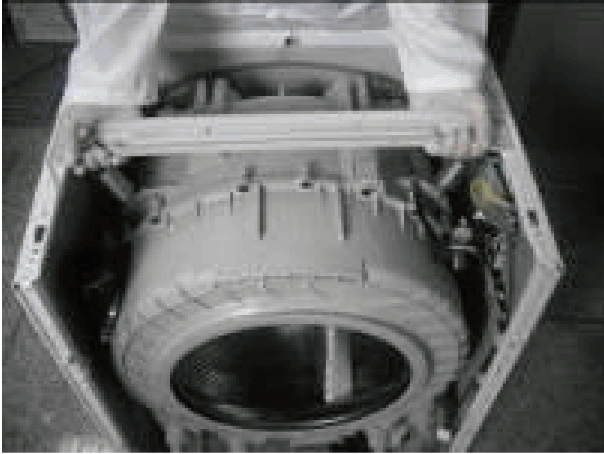

10.22. Shock Absorber Pin

1. Remove shock absorber pins squeezing the ratchet by a pliers.



10.23. Belt

1. Remove the belt rotating the driven pulley.



10.24. Driven Pulley

1. Remove the bolt at the center of pulley by tucking a wooden bar avoids rotation.



2. Remove pulley.



10.25. Motor

1. Remove two screws holding motor by using box wrench.

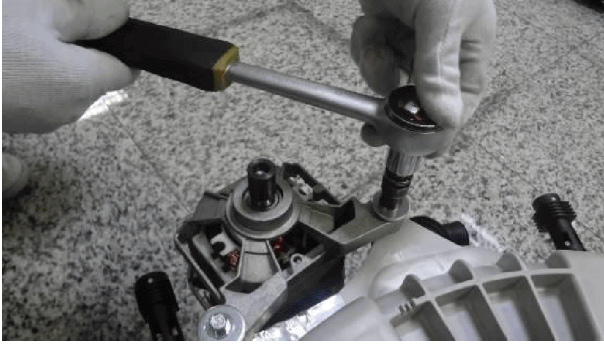

2. Pull motor up.



10.26. Tub

1. Remove tub inlet bellow hose loosening the clamp squeezing it by using a pliers.



2. Remove screw holding EPS reservoir.



3. Remove tub outlet bellowed hose loosening screwed-clamp.



4. Remove 19 screws around tub using box wrench size 8 mm.



5. Remove front tub.



6. Remove drum.



11 Component Specifications

11.1. Drain Pump

Drain pump is both a mechanical and electrical component which is used to drain water inside the washing machine. It has an synchronous motor inside. For better performance maintenance, pump filter should be cleaned regularly.

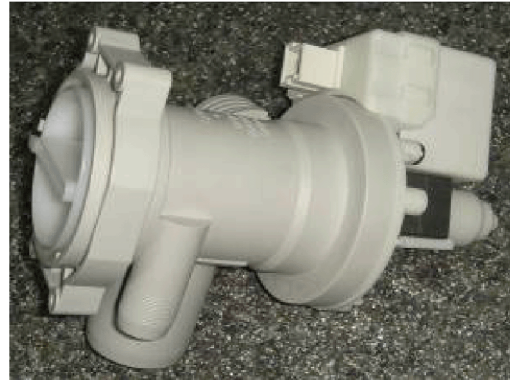

Drain pump

Technical features

Nominal voltage	220-240 V	Resistor (coil)	136 Ω ($\pm 5\%$)
Nominal current	0.28 A ($\pm 10\%$)	Water flow	17 L/min (to 1 m height)
Nominal power	37 W	Thermal protector	YES
Frequency	50 Hz		

Testing component

Check the resistance value on the component with multimeter as shown below.
Resistance value should be between 131 - 141 Ω

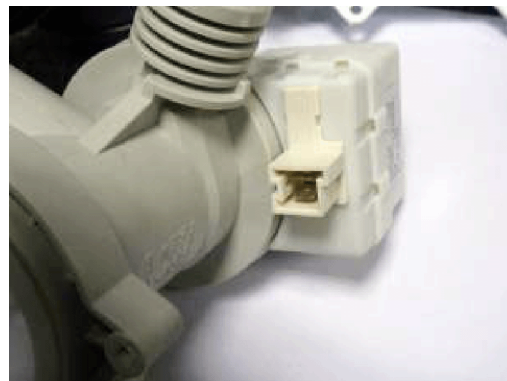

You can determine the ohm value of drain pump by measuring from the socket with two blue cables connected to the electronic card as shown in the figure.(referring X10 on the wiring diagram)

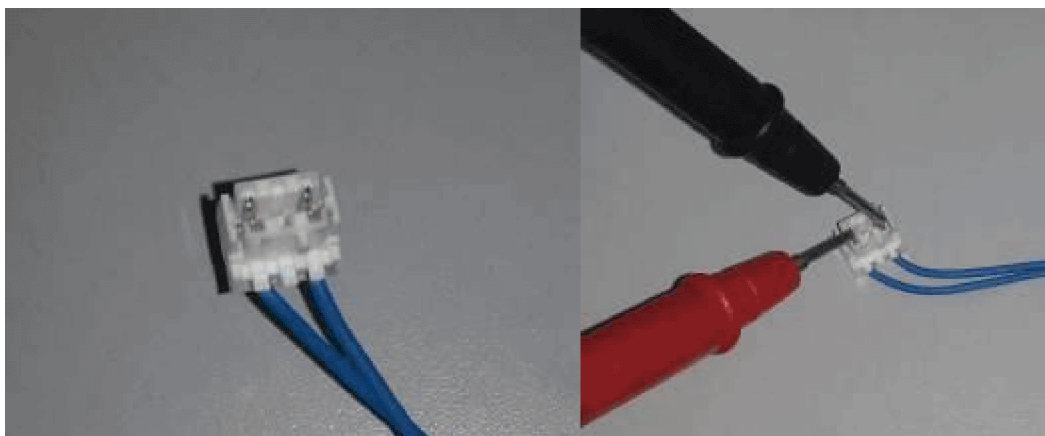

Component test

11.2. Heater

Heating element (Resistance) is a component which is designed to regulate temperature of water inside the drum. It has three connections: Phase, neutral and ground connections.



Resistance

Technical features

Heater type	Tubular heating element with NTC-sensor	Nominal power	2000 W ($\pm 5\%$)
Nominal voltage	230 V	Resistance	26.4 $\pm 5\%$ Ω
		Thermal fuse	2 sided

Testing component

Check the resistance value on the component with multimeter as shown below.
Resistance value should be between 26.4 $\pm 5\%$ Ω



You can determine the ohm value of resistance by measuring from the socket with grey and brown cables (referring to X6 on the electronic card).

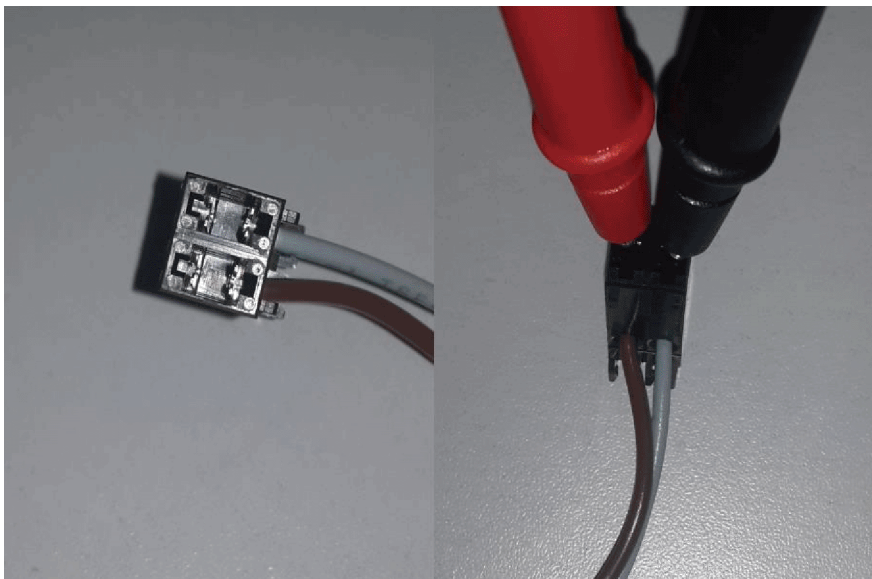

Component test

11.3. NTC

Component which sends signals to PCB about the water temperature inside the tub. The Resistance (Ohm) value of the NTC decreases as the temperature increases.



NTC

Technical features

Tem (°C)	R min (kΩ)	R max (kΩ)
-10	54.9	62.6
-5	43.0	48.6
0	33.9	38.1
5	27.0	30.1
10	21.6	23.9
15	17.4	19.1
20	14.1	15.4
25	11.5	12.5
30	9.4	10.2
35	7.8	8.3
40	6.4	6.9
45	5.4	5.7

Tem (°C)	R min (kΩ)	R max (kΩ)
50	4.5	4.7
55	3.8	3.9
60	3.2	3.3
65	2.7	2.8
70	2.3	2.4
75	1.9	2
80	1.7	1.8
85	1.4	1.5
90	1.2	1.3
95	1.1	1.1
100	0.9	1

NTC Resistance vs. NTC Temperature

Testing component

Check the resistance value on the component with multimeter as shown below.



You can determine the ohm value by measuring from the socket with two black cables (referring to X7 on the wiring diagram). NTC resistance value varies depending on temperature.



Component test

11.4. Valve

Valve is an electrical and mechanical component which is designed to take water from the network system into the washing machine. It is operated by PCB card.



Valve

Technical features

Nominal voltage	220-240 V	Rated flow	7 L/min ($\pm 15\%$)
Nominal power	8 VA	Operating water pressure	0.02 - 1 Mpa
Frequency	50-60 Hz		

Testing component

Check the resistance value on the component with multimeter as shown below. Valve water flow rate should be between 6 - 8 L/min. Each valve coil resistance values should be between 3.3 - 4.2 k Ω





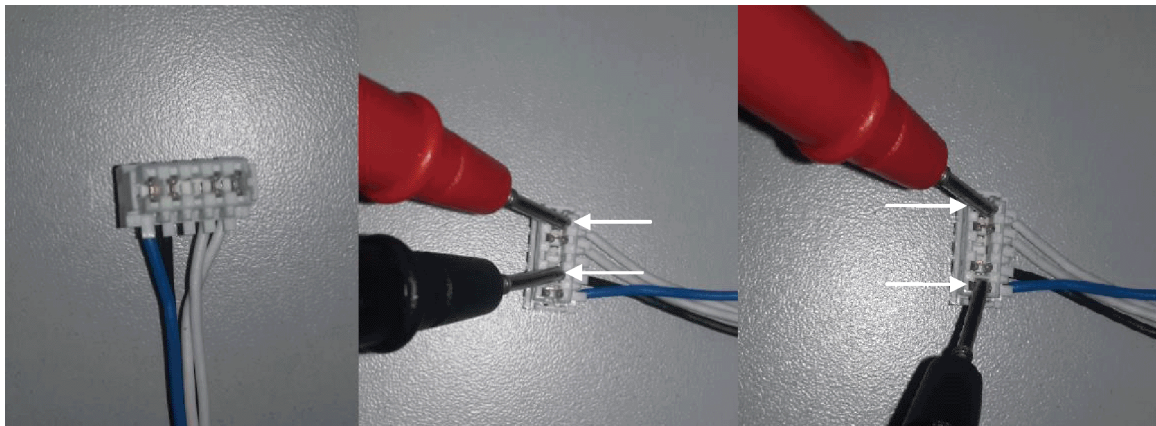

You can determine the resistance value of the main wash valve by measuring from the large socket which has one blue, one black and two white cables as shown in the figure below (refers X5 on the wiring diagram). Each valve coil resistance values should be between 3.3 - 4.2 kohm.

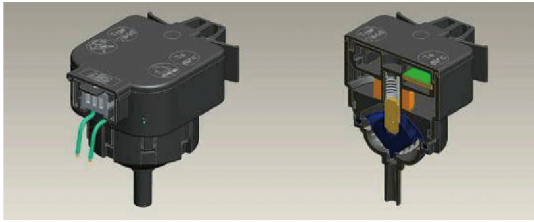

Component test

11.5. Electronic Pressure Sensor (EPS)

<p>Electromagnetic field occurs due to movement of pressurized membrane. The spring moves vertically by nucleus due to electromagnetic field. The water level is regulated according to the frequency changes of the spring by electronic card.</p>	 <p style="text-align: center;">EPS</p>
Testing component	
<p>Push the door lock slider with screwdriver.</p>	
<p>Select the 1st program and start the machine.</p>	
<p>Unplug power cable when as soon as water intake finishes and drum begins to rotate.</p>	
<p>Check the water level inside the drum with ruler. It should be 10 cm ±1.</p>	

11.6. Motor

The washing machine has an asynchronous motor. It is controlled by the PCB. It is essential to check the motor for correct diagnosis and quick servicing. In the below picture, socket points on the motor is shown to measure with multimeter.

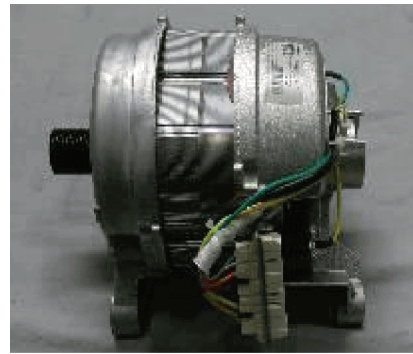

Motor

Motor socket terminals

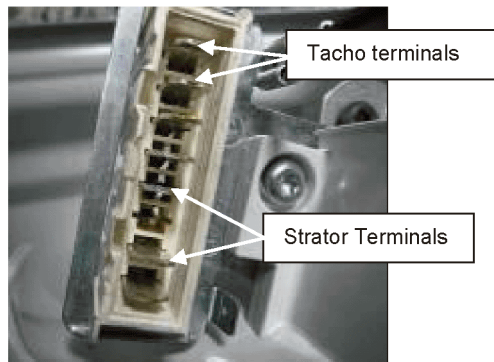

Testing components

Tacho resistance control

Check the motor tacho terminals on the motor socket with multimeter as shown in the picture above.

You can determine the ohm value by measuring from pink and red cables on the large socket as shown in the figure (referring X2 on the wiring diagram)

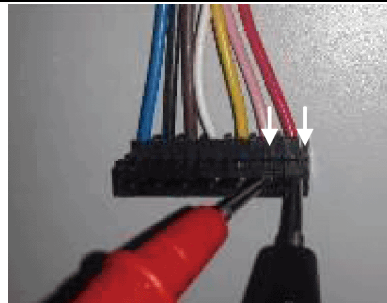

Stator Resistance Control

Check the motor stator terminals on the motor socket with multimeter as shown in the picture.

You can determine the ohm value by measuring from black and brown cables on the large (referring X2 on as shown in right figure. For resistance values, refer to the table below.

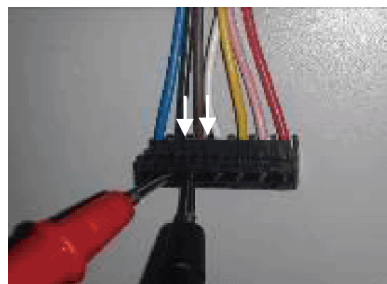

Tacho and stator resistance values of motor:

STATOR (Ω)	TACHO (Ω)	TEMPERATURE
$3,30 \pm 7\% \Omega$	$184 \pm 7\% \Omega$	20°C

11.7. Door Lock

Door lock is activated at the beginning of the program in order to prevent the door from opening. Locking is generated by supplying power to PTC-bimetal, after max 6sec (220V), the bimetal will be warm and ready to close the contacts. Thus the first impulse to the solenoid will allow the contact to close and consequently the slider will be locked by the pin of the sliderlock. The second impulse causes no electrical and mechanical modifications. It can be unlocked by the third impulse; the contact is opened even if the PTC-bimetal remains energized.

Emergency Opening System (PTC-Bimetal) In Case of Lack of Electric Energy

- In case of lack of electric energy during a washing cycle, the PTC-bimetal assembly will cool down and after minimum 60 sec (considering previous power supply of 30 sec min and $T=20\text{ }^{\circ}\text{C}$) the door will be unlocked and thus can be opened.
- In case the door is closed when current comes back, the PTC-bimetal assembly will heat again, the slider lock will lock, the contact will close and the program will continue from where it stopped.

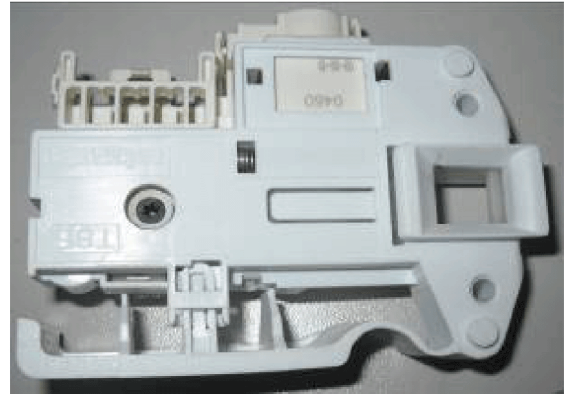

Door lock

Technical features

Nominal voltage 250 V

Testing component

Check the resistance value on the component with multi-meter as shown in below figures. Resistance value on the (PTC overload + solenoid) should be $240\Omega \pm 20\%$ at $25\text{ }^{\circ}\text{C}$. That resistance value can be measured from terminal 3-4 (refer to section12 Wiring Connection Diagram).

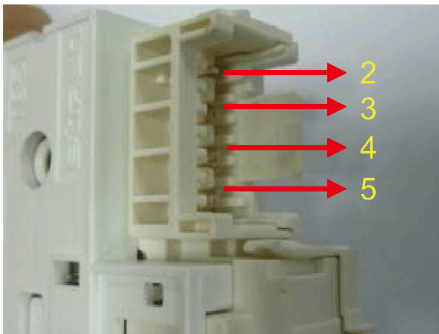

You can determine the ohm value of PTC by measuring from cables those are shown in the figure below as 3 and 4. (Referring X3 on the wiring diagram).

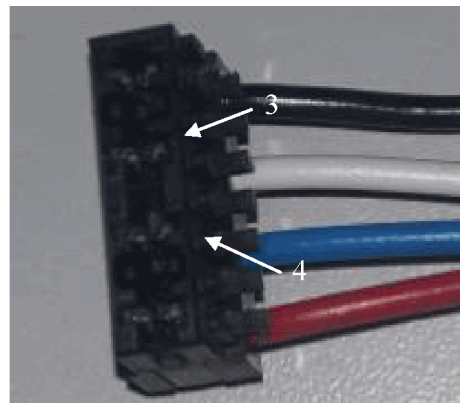
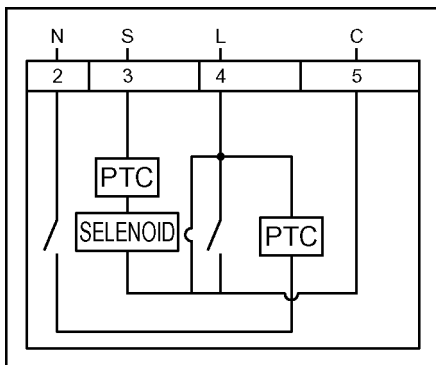

Component test

11.8. DC Module Board

- DC module electronic board is used as an additional board in DC machine models in order to convert AC voltage to DC voltage and provide bridge and relay components.
- Input of DC board is provided by X1 connector and output of board is provided by X2 connector.

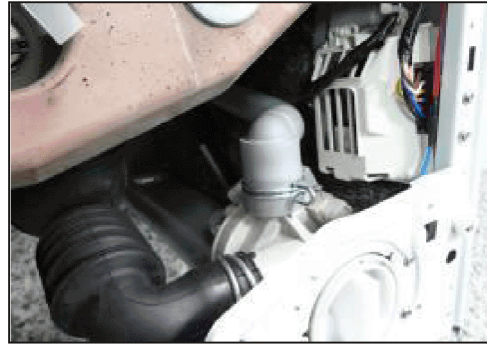
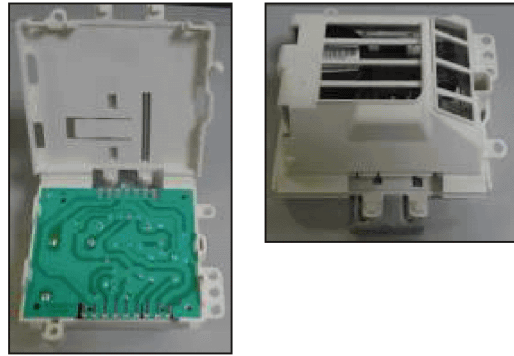

DC Module Board

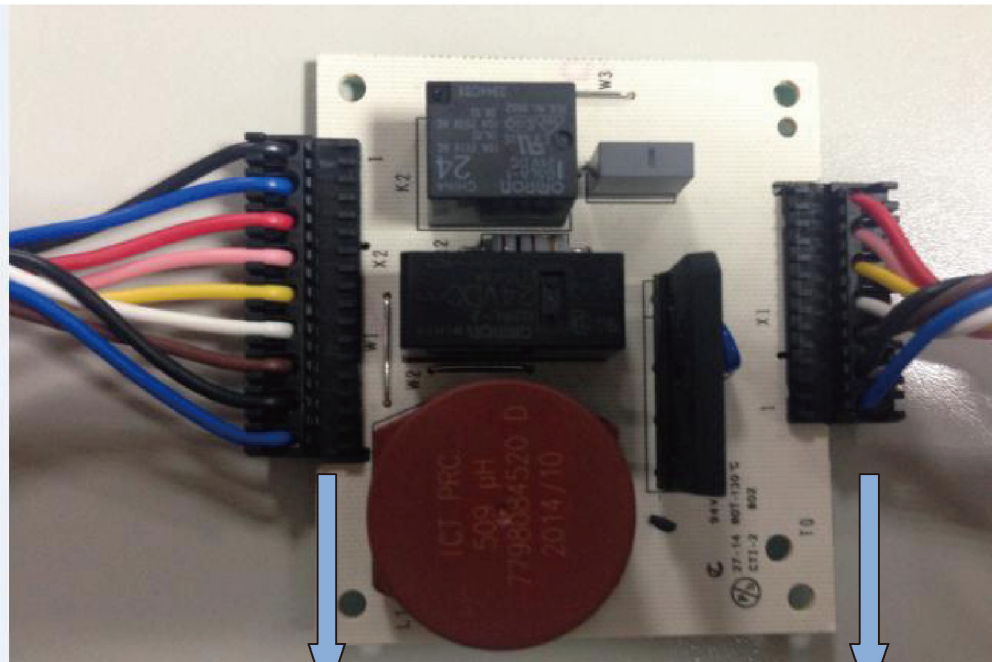

DC module-Motor
connection

DC module-Main board
connection

11.9. Circulation Pump

The component is used for circulation of water inside the drum in order to increase washing performance.

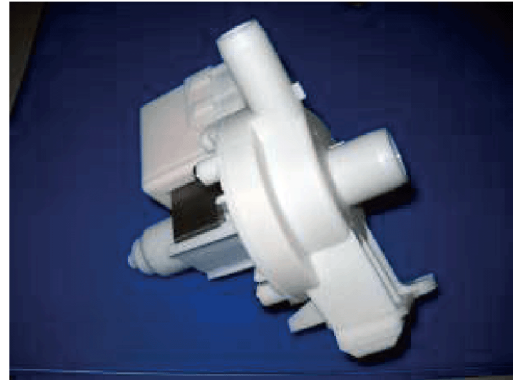

Circulation Pump

Technical features

Nominal voltage	220-240 V
Frequency	50 Hz
Resistor (coil)	169,5 Ω (\pm 5%)

Testing component

Check the resistance value on the component with multimeter as shown below.
Resistance value should be between 160 - 180 Ω



You can determine the ohm value by measuring from the red cable at 5th and red cable at 12th position in the small socket (refer wiring diagram in section 12) as shown below figure. Resistance value should be between 160 - 180 Ω

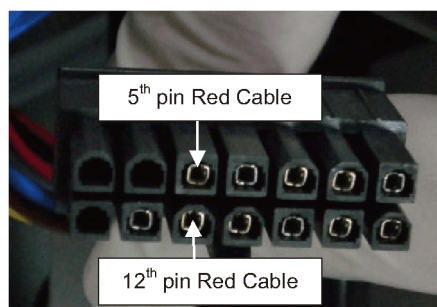

Component test

12 Wiring Connection Diagram

12.1. Wiring Diagram (Board)

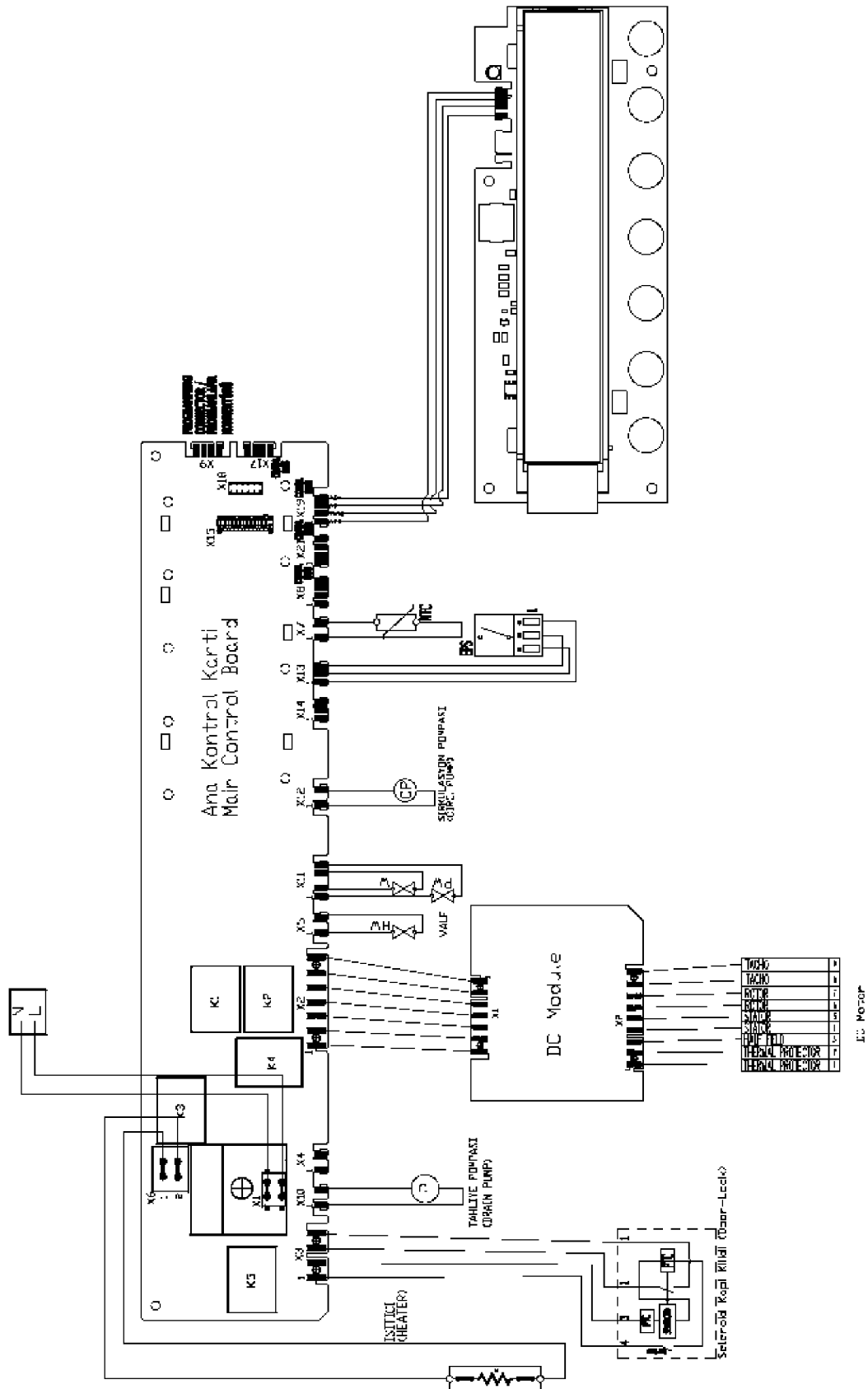

12.2. Wiring Diagram (Socket)

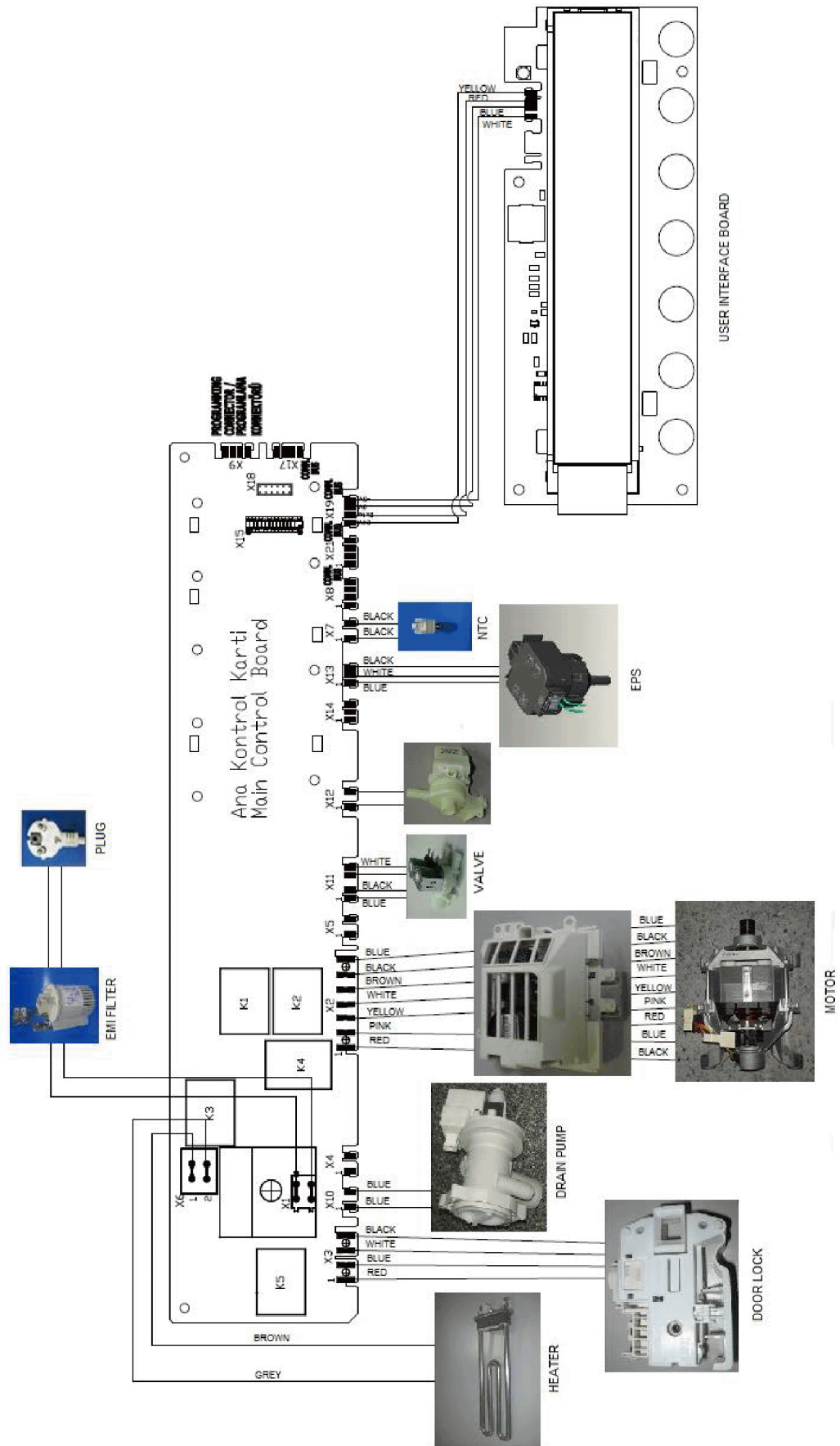

13 Exploded View and Replacement Parts List

13.1. Control Panel Spare Parts

13.1.1. Exploded View of Control Panel Parts

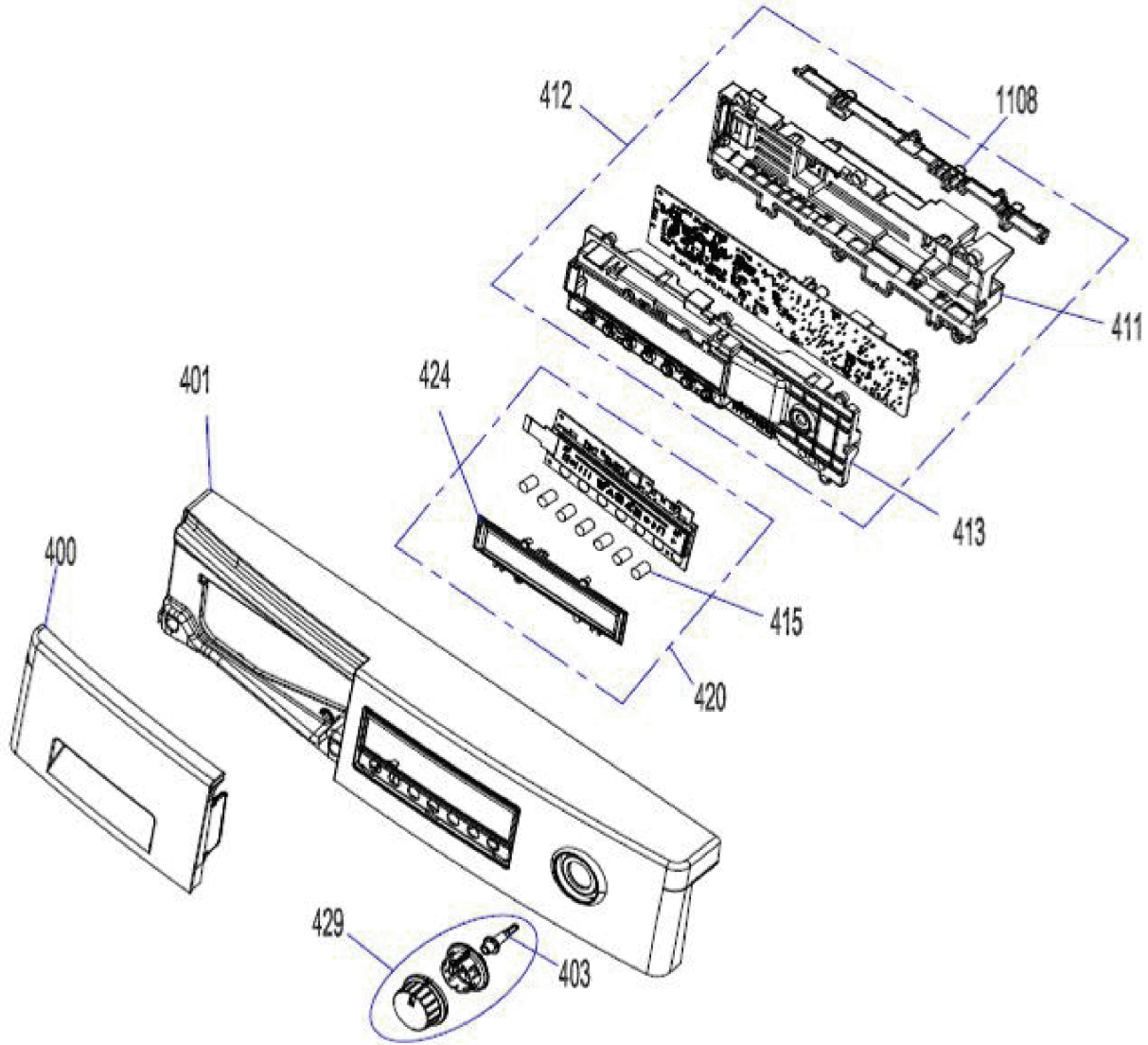

13.1.2. Control Panel Spare Parts

(U) : Indicates parts at the remarks that can be replaced by user.

⚠ : Components identified with ⚠ have special characteristics important for safety. When replacing any of these components use only manufacture's specified parts.

Safety	Ref. No.	Part Name & Description	Parts No.	Qty	Remarks
	400	DETERGENT DRAWER COVER	AXWDV-144368	1	NA-128VB6WAE
			AXWDV-144374	1	NA-128VB6WPG
	401	CONTROL PANEL	AXWCV-144367	1	NA-128VB6WAE
			AXWCV-144373	1	NA-128VB6WPG
⚠	412	ELECTRONIC CARD GR.	AXW24V-64704	1	
	411	PCB BOX	AXWPB-128166	1	
	413	PCB BOX REAR COVER	AXW2CF-91225	1	
	415	TOUCH BUTTONS	AXW146-19208	1	
⚠	420	FL CARD GROUP	AXW146-57870	1	
	424	LCD FRAME	AXWLF-134899	1	
	403	PROGRAM ADJUSTMENT SHAFT	AXWSH-069325	1	
	429	PR. ADJ.KNOB GR	AXWSH-132581	1	
	1108	SOCKET HOLDER/K200-1	AXWSH-132583	1	

13.2. Front Panel Spare Parts

13.2.1. Exploded View of Front Panel Spare Parts

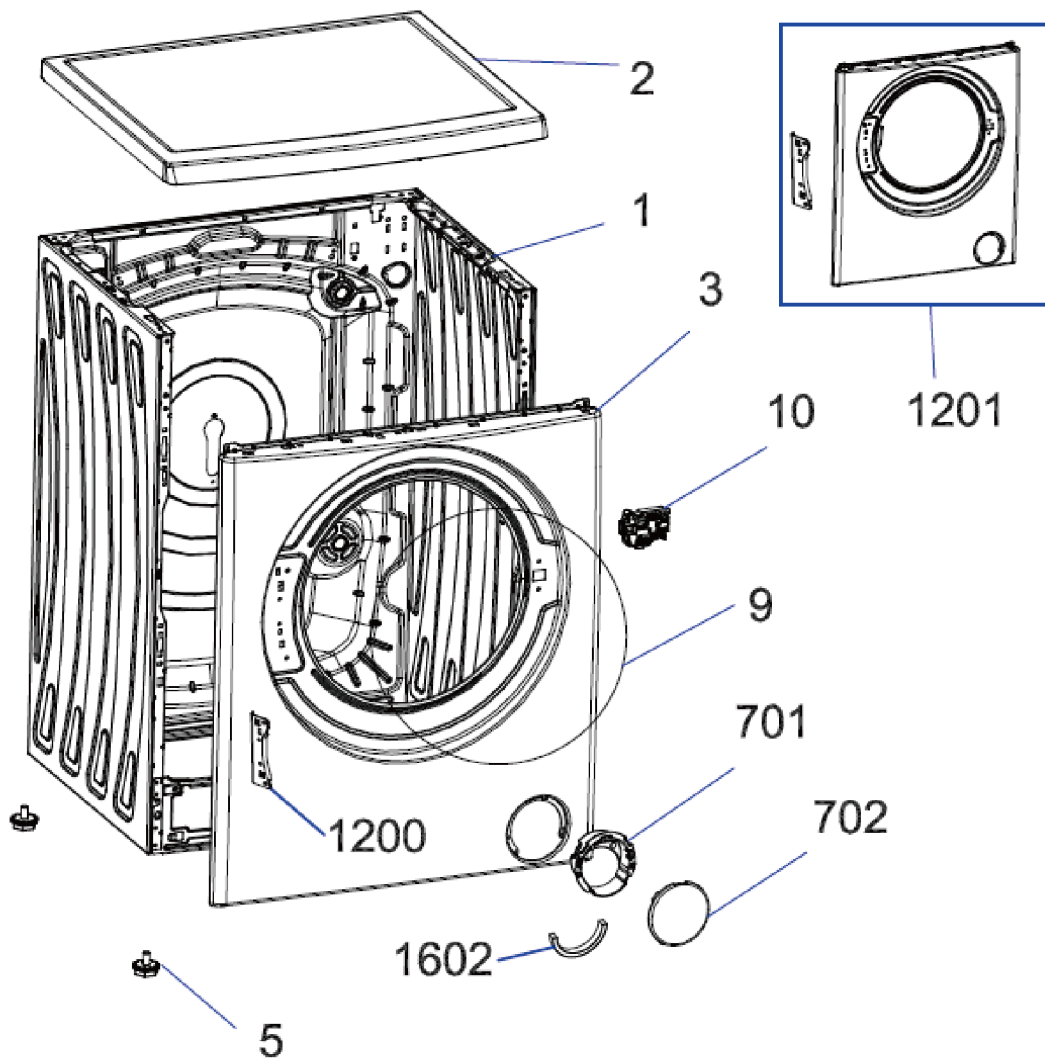

13.2.2. Front Panel Spare Parts List

Safety	Ref. No.	Part Name & Description	Part No.	Qty	Remarks
	1	BODY GROUP PAINTED	AXW1AB-13521	1	
	2	UPPER TRAY GROUP	AXW11N-16357	1	
	3	FRONT PANEL GROUP	AXW1BB-27924	1	
	5	ADJUSTABLE FEET GR.	AXW31-00778	4	
	9	HOUSING FRAME BELLOW CLIP-PHY-TON	AXW1Z-023407	1	
△	10	DOOR LOCK	AXW1619-4463	1	
	701	PUMP COVER HOUSING	AXW130-05807	1	
	702	PUMP COVER	AXW140-67962	1	
	1200	HINGE SUPPORT SHEET	AXWHSS-19456	1	
	1201	FRONT PANEL GROUP (3+1200)	AXW1BB-54562	1	
	1602	DRAIN HOSE SPONGE	AXW1DH-12749	1	

13.3. Washing Group Spare Parts

13.3.1. Exploded View of Washing Group Spare Parts

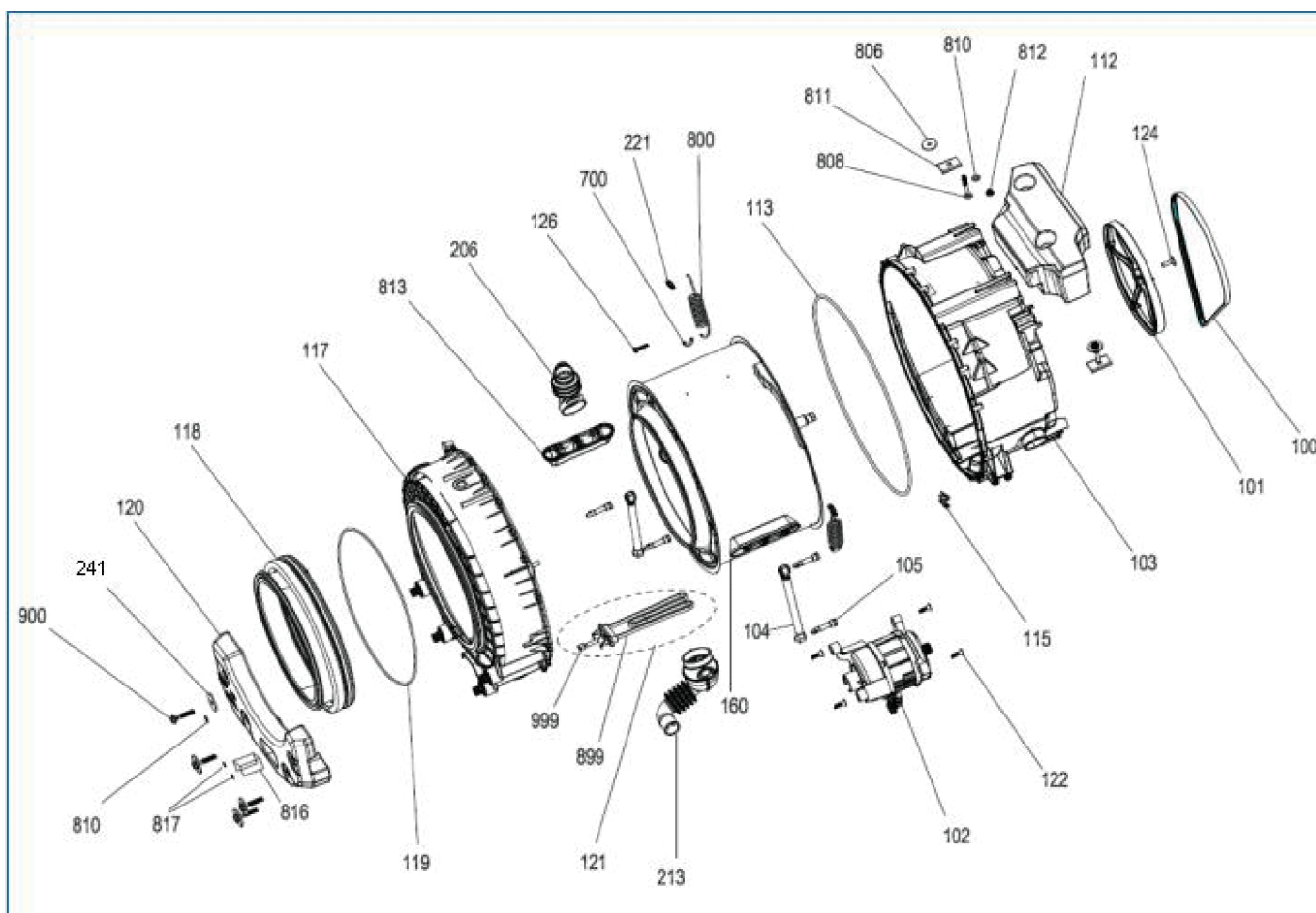

13.3.2. Washing Group Spare Parts List

Safety	Ref. No.	Part Name & Description	Part No.	Qty	Remarks
	103	REAR TUB GROUP	AXW12A-37596	1	
	117	FRONT TUB	AXW32G-26347	1	
	160	DRUM GROUP	AXW22B-13470	1	
△	102	MOTOR	AXW401-16256	1	
	113	TUB SEAL	AXW212-15077	1	
	101	DRIVEN PULLEY	AXW502-00499	1	
	100	BELT	AXW412-25178	1	
	122	COUNTERSUNK HEAD BOLT 8×28 TORX	AXWSS1-07899	4	
	206	TUB ENTERANCE WITH BELLOW HOSE	AXWEBH-87110	1	
	118	TUB BELLOWS SEAL	AXW212-25995	1	
	126	HEXAGON HEAD BOLT 6×30 PT	AXWSS3-15518	19	
	900	HEXAGON HEAD BOLT 10×52	AXWSB1-23804	4	
	241	PLAIN WASHER 10.5×40×2.5	AXW420-08965	4	
	810	PLAIN WASHER (SAFETY)	AXWSW1-06960	4	
	105	SHOCK ABSORBER PIN-2	AXWSAP-25094	4	
	119	TUB GASKET CLIP	AXW212-08555	1	
	120	FRONT CONCRETE WEIGHT	AXW1231-9244	1	
△	121	RESISTANCE GR	AXWRG1-96002	1	
△	999	NTC	AXW1EV-35970	1	
△	899	RESISTANCE WITHOUT NTC	AXWRG1-16814	1	
	115	RESISTANCE FIXING WIRE	AXWRFW-18738	1	
	104	SHOCK ABSORBER	AXWSA1-11587	2	
	213	TUB EXIT BELLOWS GR(HOSE+BALL)	AXW1250-7585	1	
	124	COUNTERSUNK HEAD BOLT M 8×29	AXWSB2-05142	1	
	700	TUB HANGER SPRING PART	AXWTHS-19298	2	
	800	TUB SPRING	AXW3441-5308	2	
	808	MUSHROOM HEAD SQUARE NECK BOLT M 8×65	AXWSB3-03063	2	
	806	PLAIN WASHER 8.4×28×3	AXWSW2-07454	2	
	811	UPPER CRT SUPPORT SHEETIRON PART	AXWUCS-16379	2	
	812	HEX.NUT WITH FLANGE SERRATED M8	AXWXNF-06921	2	
	813	PLASTIC LIFTER	AXW1PL-56336	3	
	112	UPPER CONCRETE WEIGHT	AXW1231-0333	1	
	221	HANGER SPRING SHEETIRON PLS.	AXW1HS-16727	2	
	816	RESISTANCE PROTECTION FOIL-1-C	AXW1PF-07557	1	
	817	SCREW 3,5×7PAN HEAD WITH COLAR CROSS RE.	AXWSS4-15637	2	

13.4. Detergent Drawer Group Spare Parts

13.4.1. Exploded View of Detergent Drawer Group Spare Parts

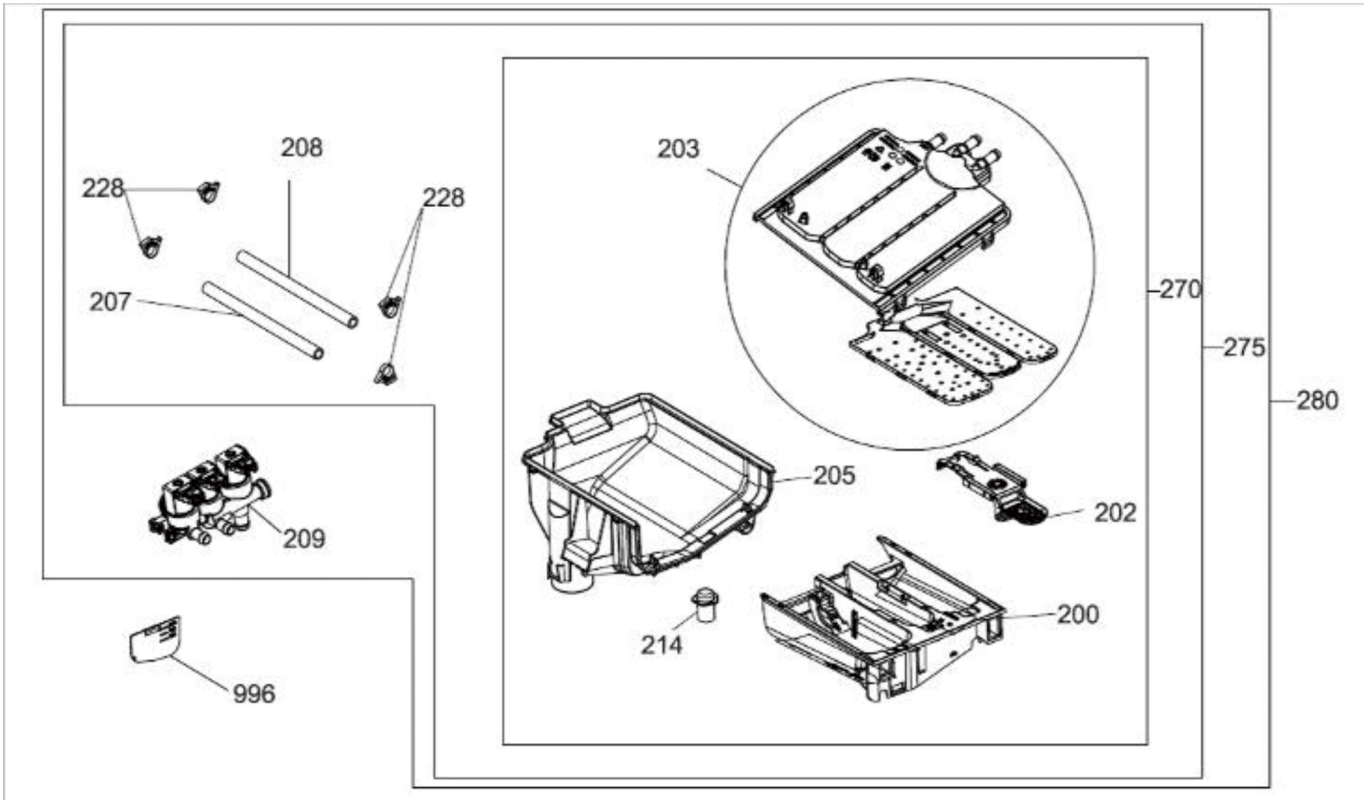

13.4.2. Detergent Drawer Group Spare Parts List

Safety	Ref. No.	Part Name & Description	Part No.	Qty	Remarks
	200	DETERGENT DRAWER	AXW1V-065303	1	
	202	SIPHON COVER	AXW1PV-65308	1	(U)
	214	DETERGENT DRAWER LOC.PART-BLUE	AXW1DD-65309	1	
	203	WATER DISTRIBUTION PLATE GR	AXW1WD-65322	1	
	205	DETERGENT DRAWER HOUSING	AXW1DD-65304	1	
	228	PLASTIC HOSE CLAMP	AXW1PH-04189	4	
	207	VALVE-DETERGENT BOX HOSE	AXW1VD-04536	1	220mm
	208	VALVE-DETERGENT BOX HOSE	AXW1VD-07796		240mm
△	209	VALVE(TWO EXIT)	AXW1VT-13042	1	
	270	DETERGENT BOX GROUP	AXW21D-65326	1	
	275	DETERGENT BOX GROUP/HOSE	AXW31D-65331	1	
	280	DETERGENT BOX GROUP/FULL	AXW41D-10243	1	
△	996	LIQUID DETERGENT LEVEL PLATE	AXW51D-65310	1	

13.5. Pressure Switch Hose Group Spare Parts

13.5.1. Exploded View of Pressure Switch Hose Group Spare Parts

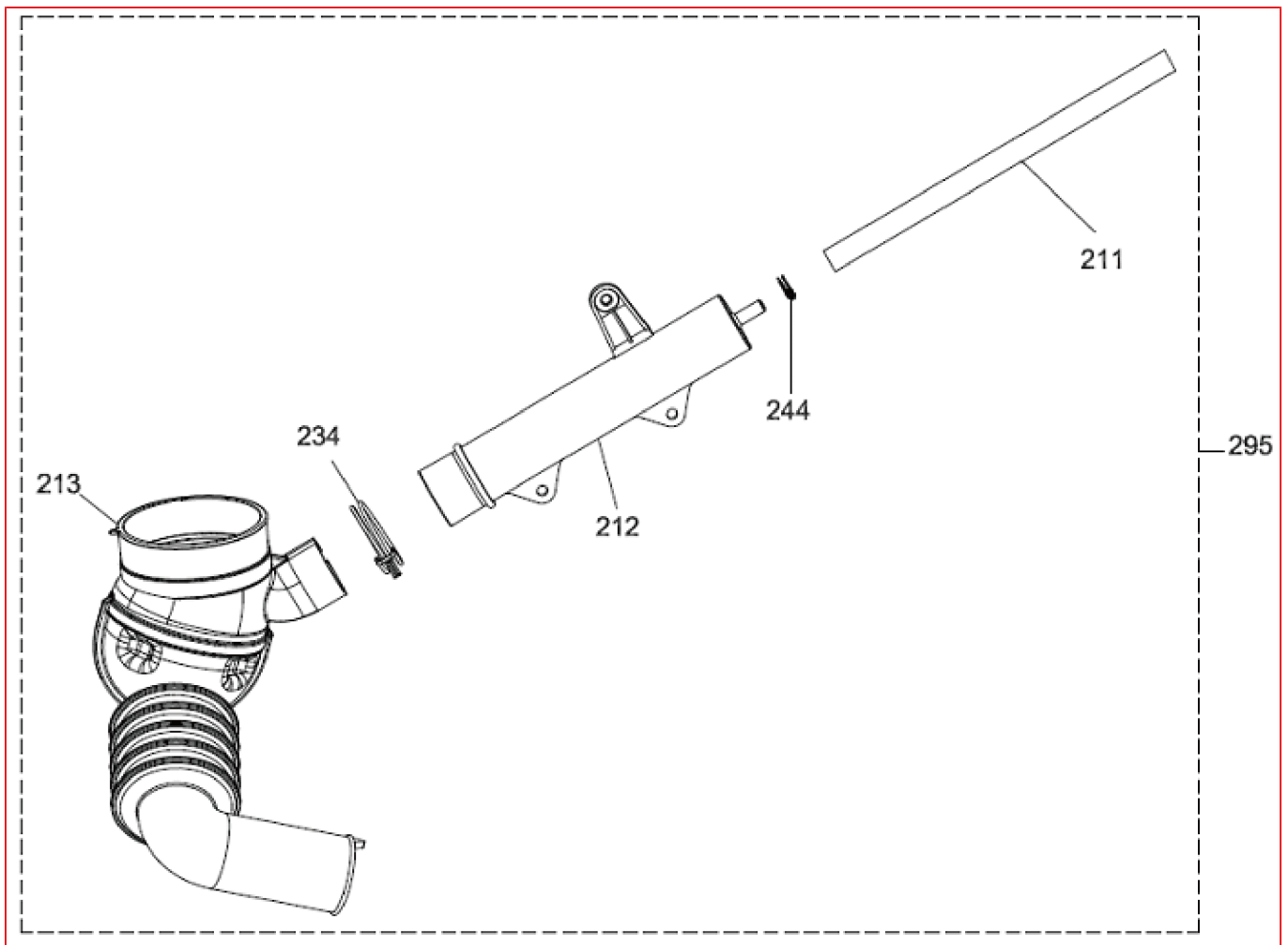

13.5.2. Pressure Switch Hose Group Spare Parts List

Safety	Ref. No.	Part Name & Description	Part No.	Qty	Remarks
	211	PRESSURE SWITCH HOSE (EPDM)	AXW1PS-78599	1	
	212	PRESSURE SWITCH WATER RESERVOIR	AXW1PS-88879	1	
	213	TUB EXIT BELLOWS GR(HOSE+BALL)	AXW1250-7585	1	
	234	HOSE CLAMP ϕ 32,7	AXW1HC-07366	1	
	244	HOSE CLAMP ϕ 9,6	AXW1HC-08991	1	
	295	PRESSURE SWITCH HOSE GR.PYTHON BALL SYST	AXW2PS-79698	1	

13.6. Body Group Spare Parts

13.6.1. Exploded View of Body Group Spare Parts

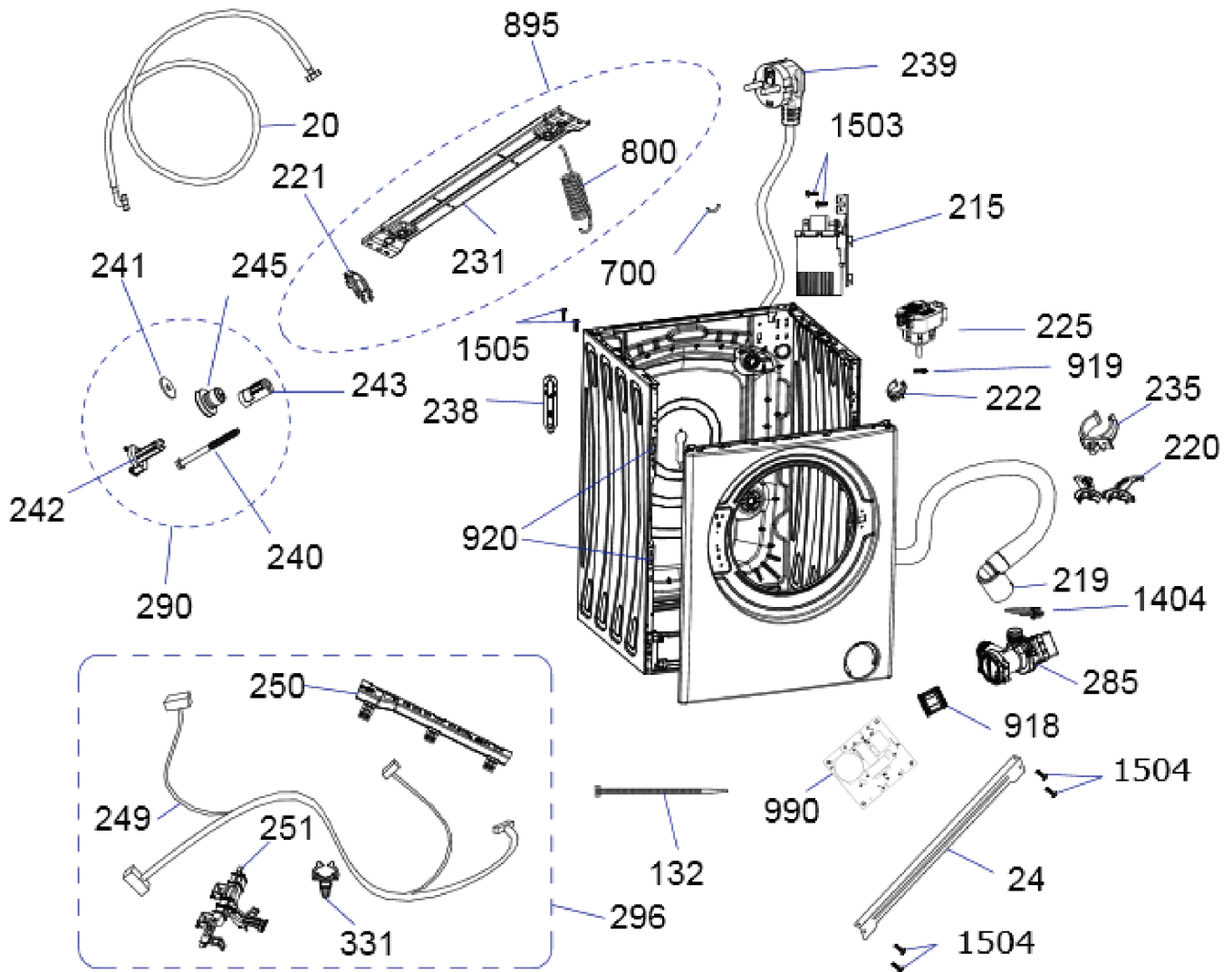

13.6.2. Body Group Spare Parts List

Safety	Ref. No.	Part Name & Description	Part No.	Qty	Remarks
	20	WATER ENTRY HOSE GROUP	AXW12C-14423	1	
	24	UPPER SUPPORT BRAKET	AXW1US-96100	1	
△	285	PUMP GROUP	AXW8FT-06391	1	
	220	DRAIN HOSE ROUTER PLASTIC	AXW1DH-19322	1	
	219	DRAIN HOSE	AXW1DH-74837	1	
△	225	ELECTRONIC PRESSURE SENSOR	AXW1EP-06187	1	
△	215	EMI FILTER	AXW2EF-15002	1	
△	296	CABLE GR	AXW2CB-26676	1	
△	249	CABLE HARNESS	AXW14B-26677	1	
	250	CABLE HARNESS HOLDER PLS	AXW1CH-93407	1	
	251	CABLE HOLDER AND ROUTER PLASTIC	AXW1CH-28367	1	
	331	PUSH MOUNT CABLE-TIE-110*2,5MM	AXW1CH-85086	1	
	895	SPRING HANGER BRACKET GROUP	AXW1SH-44195	1	
	800	TUB SPRING	AXW3441-5308	2	
	231	SPRING HANGER BRACKET	AXW2SH-79359	1	
	221	HANGER SPRING BRACKET PLS.	AXW1HS-16727	2	
	700	TUB HANGER SPRING PART (PLASTIC HOUSING PART BETWEEN TUB AND SPRING HOOK)	AXWTHS-19298	2	
	235	DRAIN HOSE HOLDING PLS	AXW1HC-14270	4	
△	239	POWER CORD GROUP	AXW4A-17512	1	NA-128VB6WAE
			AXW4A-17511	1	NA-128VB6WPG
	222	PRESSURE SWITCH MOUNTING CLIP	AXW1HC-22768	1	
	238	SPEED CONTROL HOLE STOPPER	AXW1SC-06161	1	
	290	TRANSPORT SCREW GROUP-II	AXW2TS-15676	4	
	242	TRANSPORT SCREW PLASTIC-A-II	AXW1TS-18528	4	
	243	TRANSPORT SCREW PLASTIC-B-II	AXW1TS-60789	4	
	240	TRANSPORT SCREW	AXWSB4-08363	4	
	245	TRANSPORT SCREW EPDM	AXW1TS-60790	4	
	241	PLAIN WASHER 8,30×29×2	AXWSW1-15272	4	
	132	CABLE TIE(YKB150)	AXWCT-075920	7	
	918	DRAIN FILTER	AXWDF-120197	1	
	919	HOSE CLAMP ϕ 8,6	AXWHC-003440	1	
	920	FRONT PANEL DROP FIXING PLASTIC-II	AXW1TP-20456	4	
△	990	DC CARD	AXW24V-57871	1	
	1404	HORT.KLPC. ϕ 35,0	AXWHC-006977	1	
	1503	ST 4,2×9,5 PAN HEAD W.COL.T.UNDER.SER.EA	AXWSS7-16042	2	
	1504	ISO 7049 ST 4,2×13 TORX	AXWSS6-14453	4	
	1505	ST 4,2×9,5 TRTSB	AXWSS5-14454	4	

13.7. Porthole Group Spare Parts

13.7.1. Exploded View of Porthole Group Spare Parts

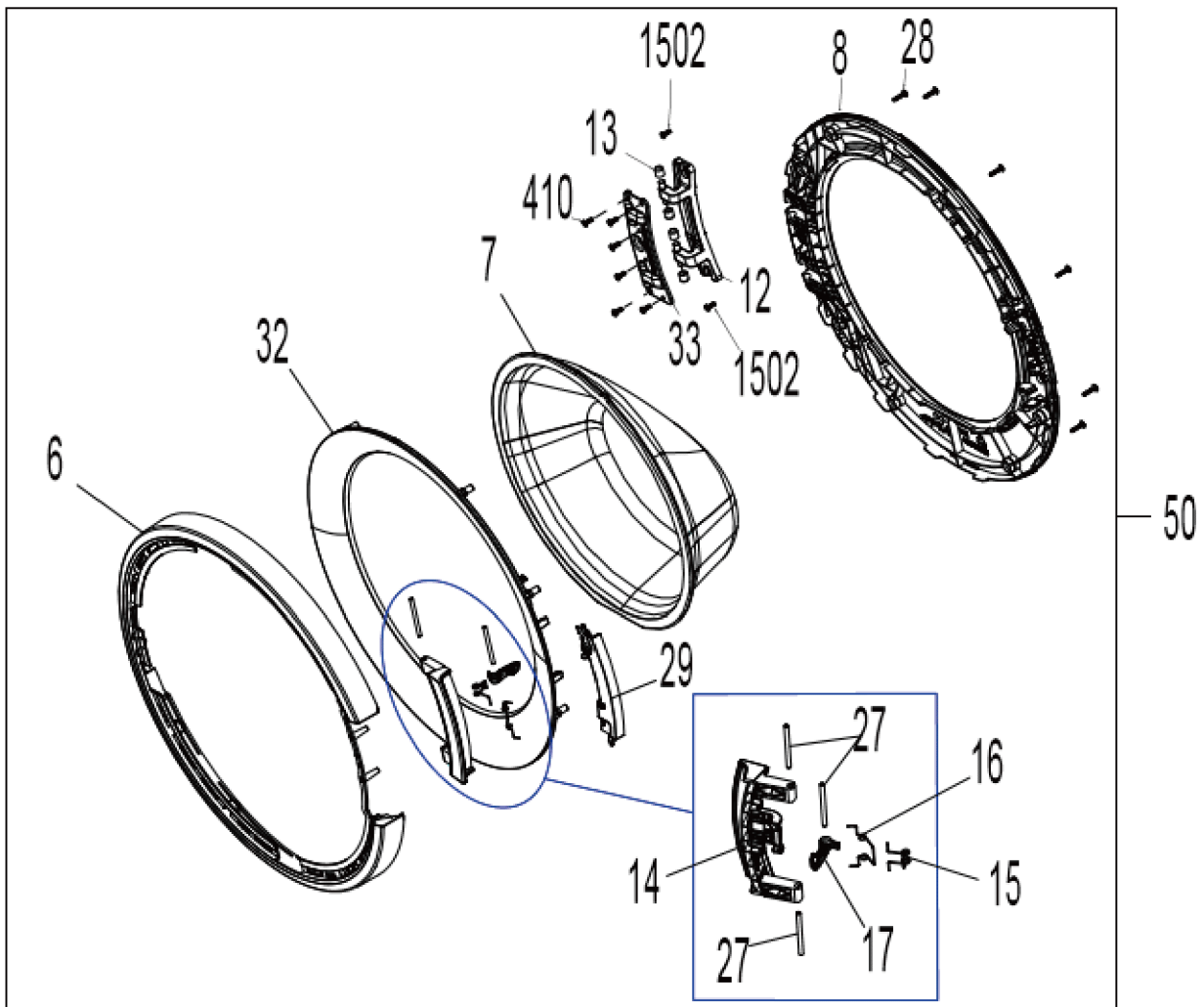

13.7.2. Porthole Group Spare Parts List

Safety	Ref. No.	Part Name & Description	Part No.	Qty	Remarks
	6	OUTER DOOR PLASTIC	AXW1DP-93322	1	
	7	DOOR GLASS	AXW1GD-03771	1	
	8	INNER DOOR PLASTIC	AXW1DP-86999	1	
	12	HINGE II-M5	AXW192-15559	1	
	13	HINGE BUSHING II	AXW192-23907	4	
	14	DOOR HANDLE	AXW1DH-04266	1	
	15	HOOK SPRING	AXW1HS-07443	1	
	16	HANDLE SPRING	AXW1HS-14985	1	
	17	DOOR HOOK II.(METAL)	AXW1DH-08931	1	
	27	DOOR HANDLE TONGUE PIN	AXW1DH-07434	3	
	28	SCREW 3.5x16PAN.HE.WITH COL.CR.RE.UN.HE.	AXWSS7-08715	9	
	29	OUTER DOOR PLS INSERT PART	AXW1DS-06270	1	
	32	OUTER DOOR PLS. INNER FRAME	AXW1DS-80609	1	
	33	DOOR HINGE SUPPORT SHEET	AXW192-08152	1	
	50	PORTHOLE GROUP	AXW2DP-32501	1	(U)
	410	SCREW 4x12 PAN HEAD WITH COLLAR UNDER HE	AXWSB9-16360	6	
	1502	SCREW M5x8 TSB	AXWSST-15092	2	

13.8. CIRCULATION GROUP

13.8.1. Exploded View of Circulation Pump Spare Parts

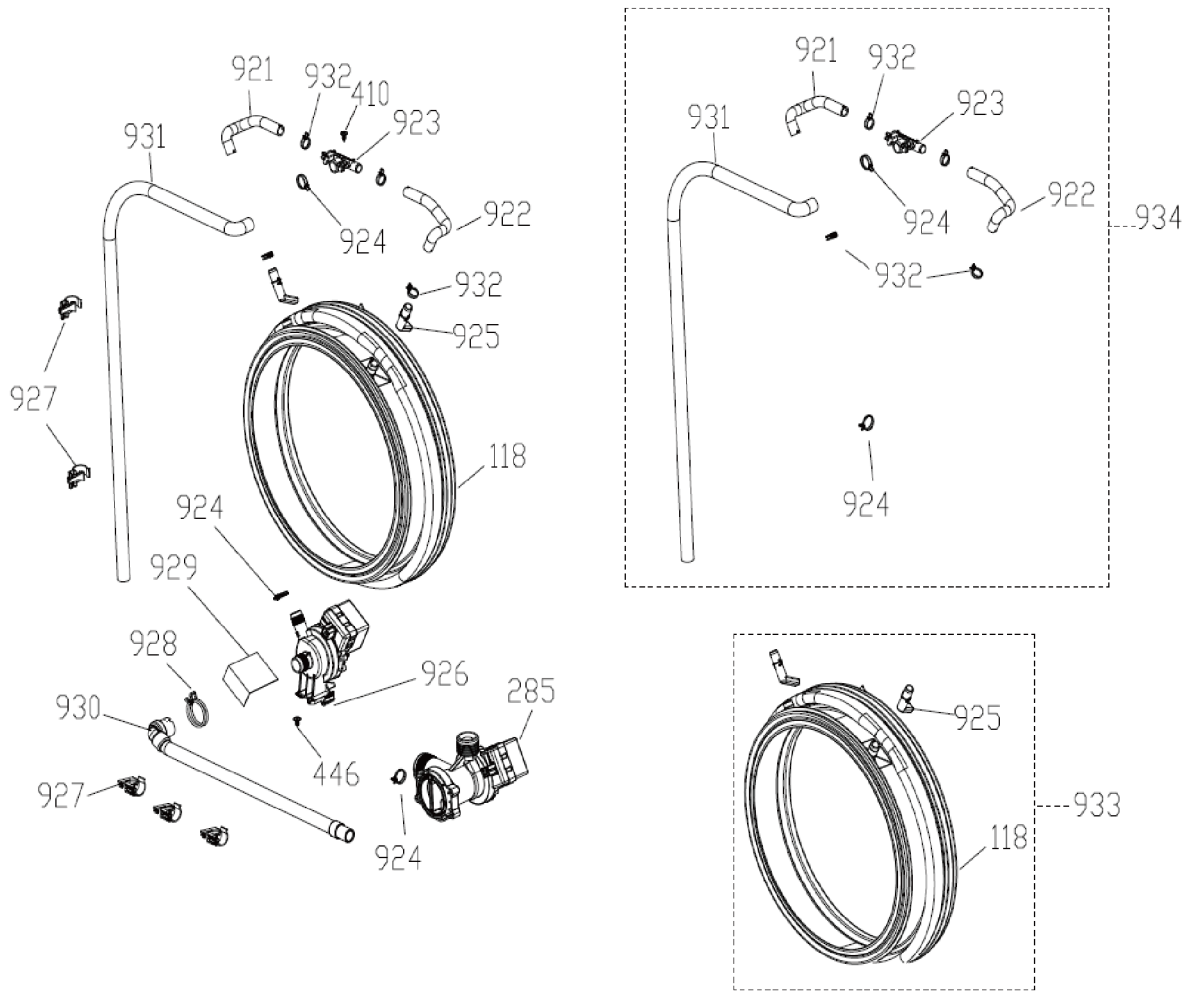

13.8.2. Circulation Pump Spare Parts List

Safety	Ref. No.	Part Name & Description	Part No.	Qty	Remarks
	118	TUB BELLOWS SEAL	AXW212-25995	1	
	285	PUMP GROUP(FILTER)(THER. PROTECT.)	AXW8FT-06391	1	
	410	SCREW 4x14 PAN HEAD TYPE 2	AXWSB8-16360	1	
	446	ISO 7049 ST 4,2x13 TYPE 2	AXWSS2-08716	1	
	921	TWIN JET HORN/LEFT	AXWTJH-25993	1	
	922	TWIN JET HORN/RIGHT	AXWTJH-25992	1	
	923	TWIN JET T-ELBOW	AXWTJT-25561	1	
	924	HANDCUFFS ϕ 20.2	AXW2HC-08653	3	
	925	TWIN JET NOZZLE	AXWTJN-25574	2	
	926	CIRCULATION PUMP	AXW8CP-08568	1	
	927	TWIN JET CABLE HOSE HOLDER PLASTIC	AXWTJC-25867	5	
	928	HANDCUFFS ϕ 26.8	AXW2HC-09578	1	
	929	PUMP PROTECTION FOIL-3	AXW1PF-10025	1	
	930	TWIN JET HOSE_N NO:1	AXWTJH-25194	1	
	931	TWIN JET HOSE_H NO:2	AXWTJH-31321	1	
	932	HANDCUFFS ϕ 15.88	AXW2HC-08652	4	
	933	PYTHON-CIRCULATION TUB GASKET GR	AXWTJH-31321	1	
	934	TWIN_JET HOSE GROUP	AXWTJH-34816	1	

13.9. Accessories

13.9.1. Accessories



994



995

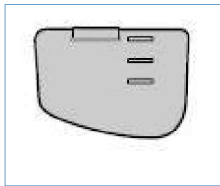

996



997



998

13.9.2. Accessories Spare Parts List

Safety	Ref. No.	Part Name & Description	Part No.	Qty	Remarks
	994	USER'S MANUAL	AXW4F-174912	1	NA-128VB6WAE ENGLISH
			AXW4F-174913	1	NA-128VB6WAE ARABIC
			AXW4F-174925	1	NA-128VB6WPG ENGLISH
			AXW4F-174926	1	NA-128VB6WPG ARABIC
	995	ENERGY LABEL	AXW90EL-4915	1	NA-128VB6WAE
			AXW90EL-4927	1	NA-128VB6WPG
	996	LIQUID DETERGENT LEVEL PLATE	AXW51D-65310	1	
	997	DRAIN HOSE COAT RACK	AXW90HC-0601	1	
	998	TRANSPORT SCREW STOPPER	AXW1TS-16405	4	

13.10. Packaging Group Spare Parts

13.10.1. Exploded View of Packaging Group Spare Parts

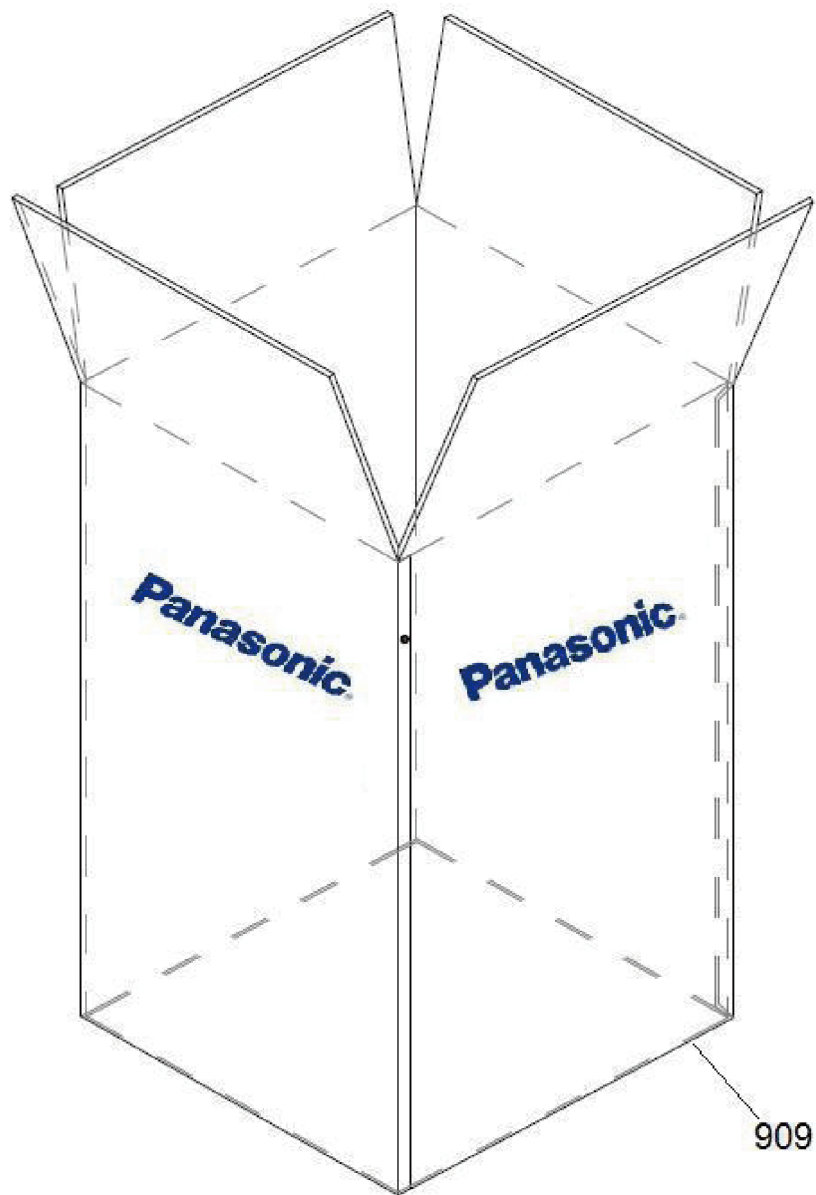

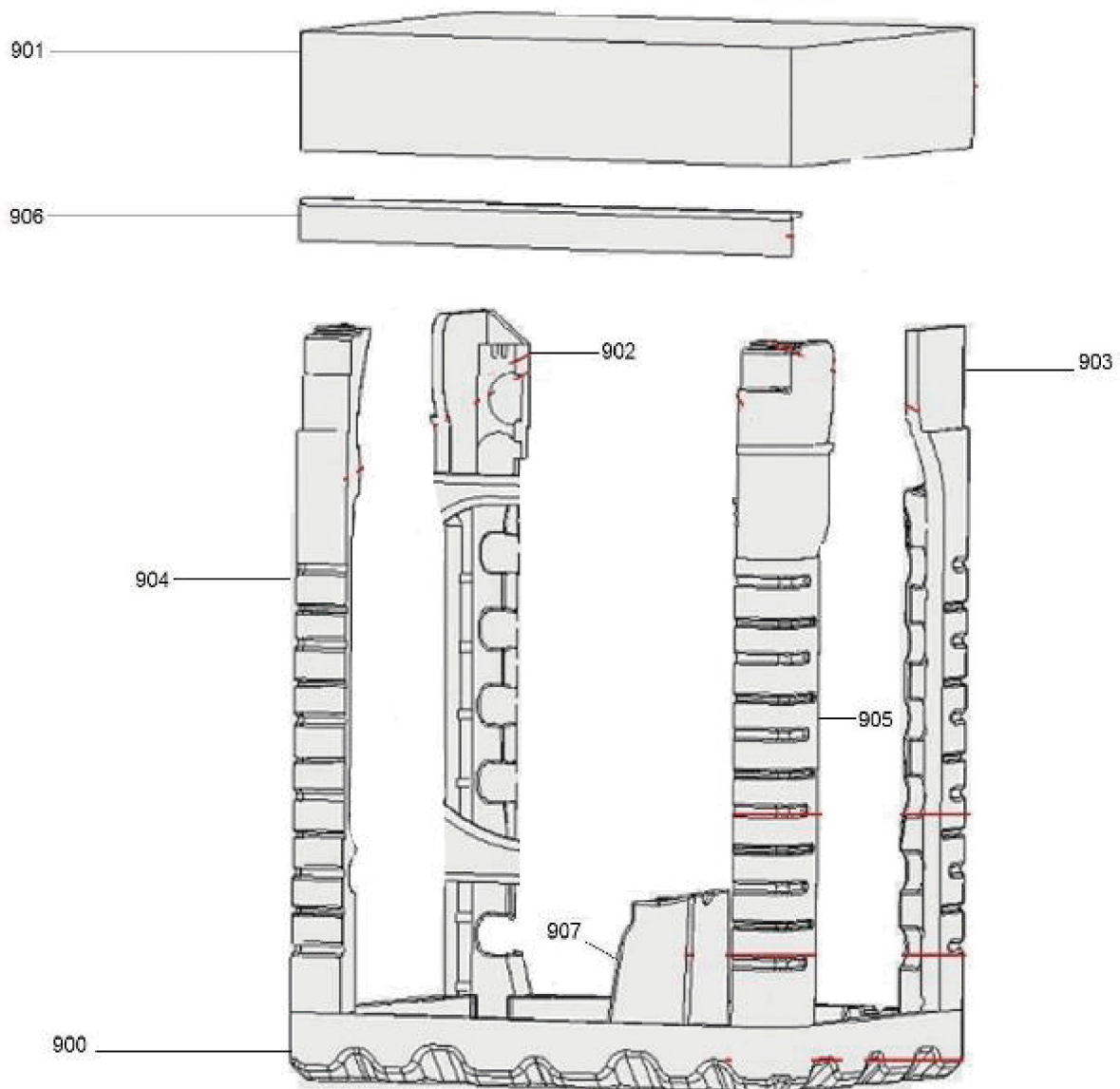

13.10.2. Package Group Spare Parts List

Safety	Ref. No.	Part Name & Description	Part No.	Qty	Remarks
	900	BOTTOM STYROFOAM	AXWPV-015438	1	
	901	TOP CARTON	AXWPV-152487	1	
	902	REAR STYROFOAM(LEFT)	AXWPV-277830	1	
	903	REAR STYROFOAM(RIGHT)	AXWPV-277820	1	
	904	FRONT STYROFOAM LEFT	AXWPV-277810	1	
	905	FRONT STYROFOAM RIGHT	AXWPV-280760	1	
	906	CORNER CARDBOARD	AXWPV-002040	1	
	907	TUB SUPPORT STYROFOAM	AXWPV-053000	1	
	909	PACKAGE CARTON	AXWPV-160505	1	