

# Service Manual

## Drum Type Washing Machine

Model No. **NA-107VC4W01**

Product Color : White

Destination : India

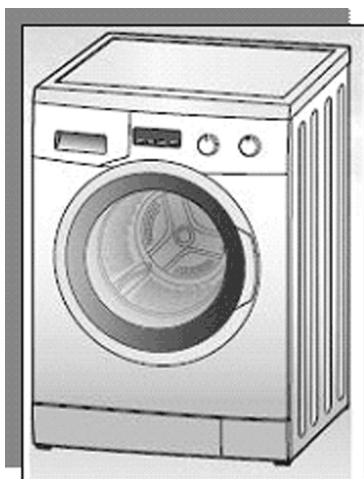

### **⚠ WARNING**

This service information is designed for experienced repair technicians only and is not designed for use by the general public. It does not contain warnings or cautions to advise non-technical individuals of potential dangers in attempting to service a product. Products powered by electricity should be serviced or repaired only by experienced professional technicians. Any attempt to service or repair the product or products dealt with in this service information by anyone else could result in serious injury or death.

### **IMPORTANT SAFETY NOTICE**

There are special components used in this equipment which are important for safety. These parts are marked by **⚠** in the Schematic Diagrams, Circuit Board Diagrams, Exploded Views and Replacement Parts List. It is essential that these critical parts should be replaced with manufacturer's specified parts to prevent shock, fire or other hazards. Do not modify the original design without permission of manufacturer.

## TABLE OF CONTENTS

	PAGE		PAGE
<b>1 Safety Precautions</b> -----	<b>3</b>	7.1. Service Autotest-----	13
<b>2 Specifications</b> -----	<b>4</b>	7.2. Failure Codes-----	14
2.1. Product Specifications-----	4	<b>8 Troubleshooting Guide</b> -----	<b>15</b>
2.2. Name Plate-----	4	<b>9 Disassembly and Assembly Instructions</b> -----	<b>16</b>
<b>3 Location of Controls and Components</b> -----	<b>5</b>	9.1. Torque Values-----	16
<b>4 Installation Instructions</b> -----	<b>6</b>	9.2. Top Plate-----	17
4.1. Moving and Installing-----	6	9.3. Door-----	17
4.2. Detergent Box Group-----	7	9.4. Spring Wire-----	19
<b>5 Operating Instructions</b> -----	<b>8</b>	9.5. Detergent Drawer-----	19
5.1. LCD Screen, Function Buttons & Knobs-----	8	9.6. Control Panel-----	20
5.2. Program List-----	8	9.7. Kick Plate-----	21
5.3. Program Details-----	9	9.8. Front Panel-----	21
5.4. Program Details with Half Load Defection-----	9	9.9. Upper Support Bracket-----	23
5.5. Child Lock-----	10	9.10. Detergent Drawer Housing-----	23
<b>6 Test Mode</b> -----	<b>11</b>	9.11. Power Cable Group and Parasite Filter-----	24
6.1. Autotest-----	11	9.12. Electronic Pressure Switch (EPS)-----	25
<b>7 Service Mode</b> -----	<b>13</b>	9.13. Door Lock-----	25

# Panasonic®



© Panasonic Corporation 2012 Unauthorized copying and distribution is a violation of law.

9.14. Pump Motor	25
9.15. Front Counterweight	26
9.16. Heater	26
9.17. Tub Bellows Seal	27
9.18. Transport Screw	27
9.19. Upper Counterweight	28
9.20. Washing Group	28
9.21. Shock Absorber PIN	29
9.22. Belt	29
9.23. Driven Pulley	29
9.24. Motor	29
9.25. Tub Entrance with Bellow Hose	30
9.26. Pressure Switch Hose Group	30
9.27. Tub	30
9.28. Drum	30
<b>10 Measurements and Adjustments</b>	<b>31</b>
10.1. Drain Pump	31
10.2. Resistance	32
10.3. NTC	33
10.4. Valve	34
10.5. Electronic Pressure Switch (EPS)	35
10.6. Motor (For NA-107VC4)	36
10.7. Door Lock	37
<b>11 Dimensions</b>	<b>39</b>
<b>12 Wiring Connection Diagram</b>	<b>40</b>
12.1. Wiring Diagram NA-107VC4	40
<b>13 Exploded View and Replacement Parts List</b>	<b>42</b>
13.1. Control Panel Parts	42
13.2. Front Panel Parts	44
13.3. Washing Group Parts	45
13.4. Detergent Drawer Group Parts	47
13.5. Pressure Switch Hose Group Parts	48
13.6. Body Group Parts	49
13.7. Porthole Group Parts	51
13.8. Accessories	52
13.9. Packaging Group Parts	54



# 1 Safety Precautions

In order to prevent any accident during repair work and ensure security of the product after repair work, somethings surely followed are explained below.

■ The level of the arised damages or dangers, when indicated contents are ignored, are classified by following indications and explained.

	<b>Warning</b> The content in the column of this indication is "Be assumed that possibly die or get seriously injured".
	<b>Attention</b> The content in the column of this indication is "Be assumed that possibly get damages or possibly only damaged object occurred".

■ Types of the contents being followed are classified by following figured symbols and explained.  
(The following is an example of expression in pictures.)

	This figured symbol means caution " <b>Attention</b> ".
	This figured symbol means must not do " <b>Prohibition</b> ".
	This figured symbol means surely execute " <b>Instructions</b> ".

## **Warning**

### Connection of cables should be done according to regular work.



- Connection of cables should be tightened reliably with strength using solderless terminal. (specified parts always using regular bonding plier)
- Install a fire protection cover (fireproof) covering connection area completely, and close opening area by tape. (Please reuse the fire protection cover which came with the product.)
- When drawing cables around, fixing those cables with cable suppression part. Do not touch rotating part, high temperature part and surface of metal.
- Be sure to replace with cable unit when any cable was snapped. When a part of the cable unit was cut you must not do the connection repair. It may be the cause of smoke, ignition or receiving an electric shock.

### Be careful about receiving an electric shock.



When doing electric connection service such as voltage measurement, please be careful enough about receiving an electric shock at electric charging parts and cable terminal parts.

### Pull out electric plug when doing repair work.



Disassembling, assembling and replacing parts should be done after pulling out electric plug. Receiving an electric shock or getting an injury may occur.

### Be sure to use specified parts.



Always use specified parts for the parts with mark  in the electric circuit diagrams and parts list. It may be the cause of smoke, ignition or damage.

### Do not touch any rotating object with hand unless it stops completely.



Slow rotation may also roll in your hands and cause injury.

### Rebuilding is prohibited.



Do not rebuild machine parts and components when repairing service. It may be the cause of damage or ignition.

### Straightly pull out or insert in huasuton terminal.



Do not twist it. It may be the cause of damage or ignition.

## **Attention**

### Please wear gloves when disassembling, replacing and assembling.



Always wear gloves to prevent an injury by the metal end face or an electric shock at the time of the electricity service.

### Please be careful to the edges of the metal end face.



Wear the working clothes of long sleeves to prevent an injury by the metal end face or please work after covering the end face with tape or towel.

## 2 Specifications

### 2.1. Product Specifications

		NA-107VC4
Product Type		Front Loader
Capacity		7 kg
Max Spin Speed		1000 r/min
Drum Volume		50 L
Energy Label Rating		A+
Energy Consumption		222 kWh / annum
Water Consumption		10337 L/annum
Noise Level	Wash	58 dBA
	Spin	77 dBA
Control Panel		LED display, E-Type
Wash Programs		15 settings
Spin Speed Setting		6 setting
Dimensions	Height	85 cm
	Width	60 cm
	Depth	58 cm
Door Opening		Large door opening
Delay Start		Yes
Color		White
Water Protection		aquastop hose for Germany only
Other Features		Child Lock Twinjet system
Packaging		Shrink package

### 2.2. Name Plate

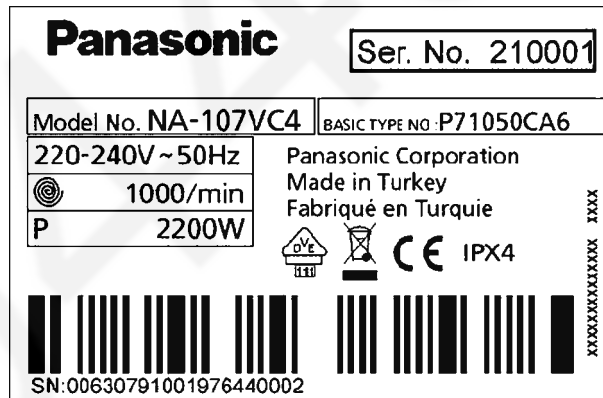



### 3 Location of Controls and Components

#### Your washing machine

Detergent drawer

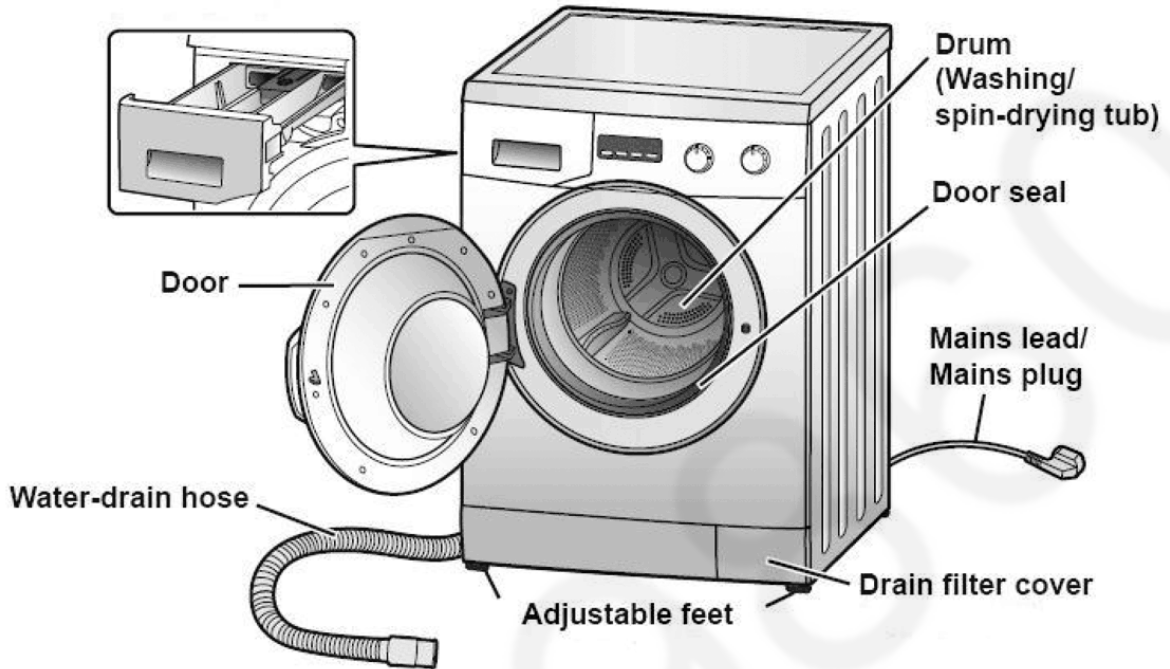

#### Caution

Do NOT bend the mains lead when the appliance is running.

#### Accessories

Make sure that all the accessories are supplied with the appliance.

#### Elbow

For fixing the water-drain hose



#### Liquid detergent level plate



#### Cover cap (x4)



#### Water-supply hose

Either one of these hoses is supplied with the appliance.



Standard  
Hose

Hose with  
water-supply valve  
(Not available for UK models)



## 4 Installation Instructions

### 4.1. Moving and Installing

#### 4.1.1. Removal of Transportation Screw

1. Transportation screws, which are located at the back side of the machine, must be removed before running the machine.
2. Loosen the screws by turning them anticlockwise with a suitable spanner.

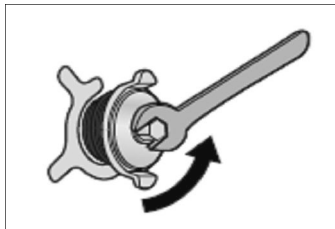

3. Pull out the screws and rubber washers.

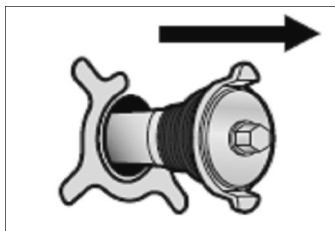

4. The holes where the transport screws have been removed should be covered with the plastic transport caps found in the accessories bag.



5. The transportation screws that have been removed from the machine must be re-used in any future transporting of the machine.

#### 4.1.2. Foot Adjustment

1. Do not install machine on rugs or similar surfaces.
2. For machine to work silently and without any vibration, it should be installed on a flat, non-slippery firm surface. Any suspended floor must be suitably strengthened.
3. You can adjust the level of machine using its feet.
4. First, loosen the plastic adjustment nut away from the cabinet base.
5. Change the level by adjusting the feet upwards or downwards.
6. After level has been reached, tighten the plastic adjustment nut again by rotating it upwards against the base of the cabinet.
7. Never put cartons, wooden blocks or similar materials under the machine to balance irregularities of the floor.

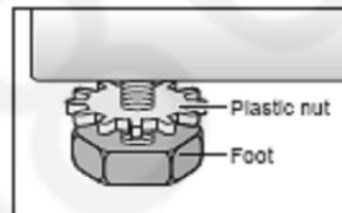

#### 4.1.3. Electrical Connection

1. Washing machine requires a 50Hz supply of 220-240Volts.
2. A special earthed plug has been attached to the supply cord of washing machine. This plug must be fitted to an earthed socket. The fuse value fitted to this plug should be 13 amps. If you have any doubts about electrical supply, consult a qualified electrician.

**THIS APPLIANCE MUST BE EARTHED.**  
**Insert the machine's plug to a grounded socket which you can easily reach.**

#### 4.1.4. Water Supply Connection

1. Washing machine is supplied with a single (cold) water inlet.
2. To prevent leakage from the connection joints, a rubber washer is included in the hose packing. Fit this washer at the end of water inlet hose on the tap side.
3. Connect the hose to the water inlet valve. Tighten the plastic connector by hand. Please call a qualified plumber if you are unsure about this.
4. Water pressure of 0,1-1 MPa from tap will enable machine to work more efficiently. (0,1 MPa pressure means water flow of more than 8 litres in 1 minute from a fully opened tap)
5. After connection is complete, check for leakage by turning on tap completely.
6. Make sure that water inlet hoses can not become folded, damaged, stretched or crushed when the washing machine is in its final position.
7. Mount the water inlet hose to a  $\frac{3}{4}$  inch threaded water tap.

#### 4.1.5. Drain Connection

1. Make sure that water inlet hoses are not folded, twisted, crushed or stretched.
2. The drain hose should be mounted at a minimum height of 60 cm, and a maximum height of 100 cm from the floor.
3. The end of the drain hose can be connected directly to a drainage stand-pipe or alternatively to a specific connection point designed for that purpose on the waste outlet of a sink unit.
4. Do not extend the drain hose or guarantee will be invalidated.

#### 4.2. Detergent Box Group

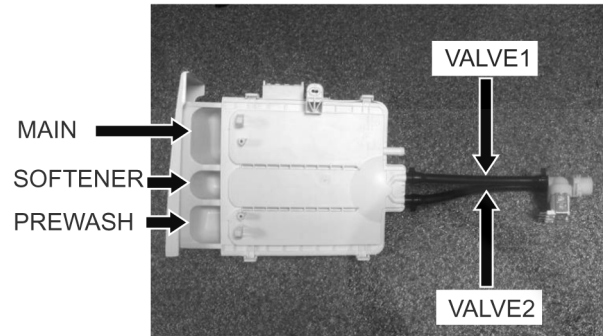

PREWASH = WATER ENTRY VALVE 1  
MAIN = WATER ENTRY VALVE 2  
SOFTENER = WATER ENTRY VALVE 1 + VALVE 2

# 5 Operating Instructions

## 5.1. LCD Screen, Function Buttons & Knobs

For NA-107VC4

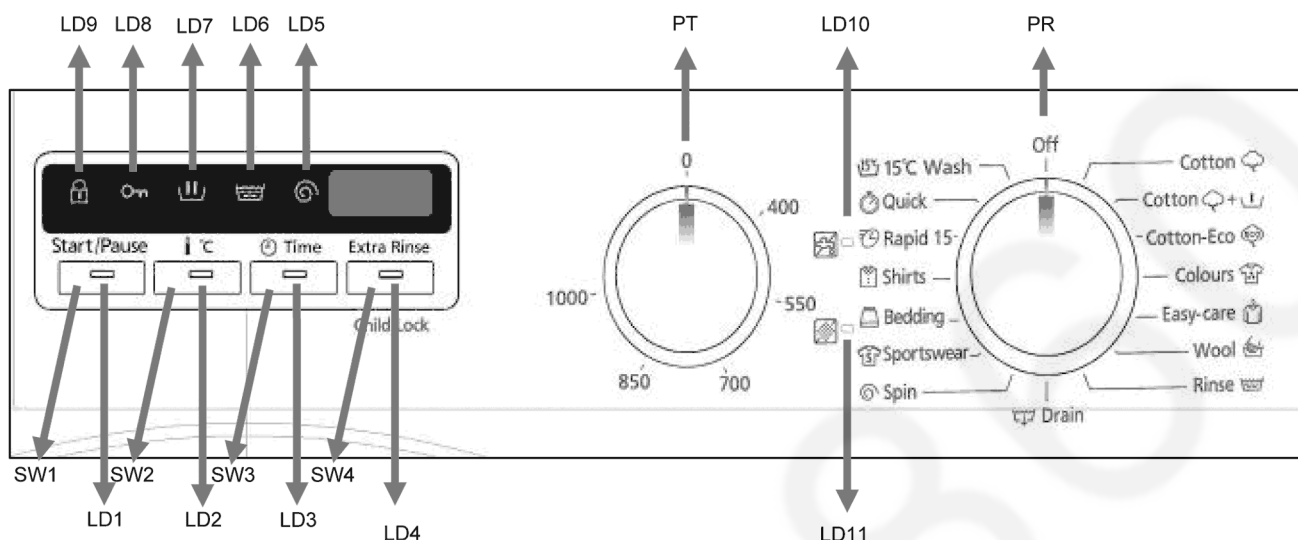

PR	Program selector 16 programs with ON/OFF.
SW1	Switch 1, Start / Pause
SW2	Switch 2, Temperature Selection
SW3	Switch 3, Delay Time Function
SW4	Switch 4, Extra Rinse
PT	PT speed potentiometer
LD1	Switch 1- Start/ Pause Led
LD2	Temperature Function Button Led
LD3	Delay Time Function Button Led
LD4	Extra Rinse Function Button Led
LD5	Spin Phase Led
LD6	Rinse Phase Led
LD7	Wash Phase Led
LD8	Child Lock Activation Led
LD9	Door Lock Led
LD10	Lack Of Water Indication Led
LD11	Pump Failure Indication Led

## 5.2. Program List

Knob Position	Program
Pos1	Cotton
Pos2	Cotton + PW
Pos3	Cotton - Eco
Pos4	Colours
Pos5	Easy-care
Pos6	Wool
Pos7	Rinse
Pos8	Drain
Pos9	Spin
Pos10	Sportswear
Pos11	Bedding
Pos12	Shirts
Pos13	Rapid 15'
Pos14	Quick
Pos15	15 °C Wash
Pos16	STOP

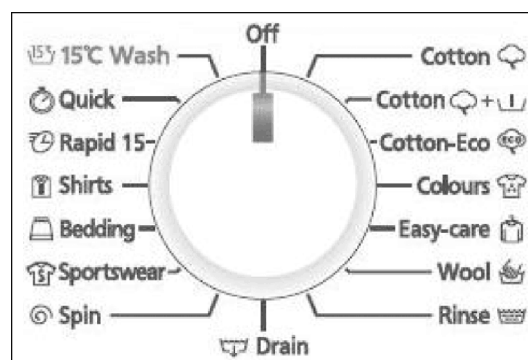

### 5.3. Program Details

Programmes	Available Temperature	Program Duration (min)*	Energy (kwh)*	Water Consumption (L)*
Cotton	Cold - 90	125	0,92	62
Cotton Eco	Cold - 60	143	0,98	74
Cotton PreWash	Cold - 60	200	1,19	50
Easy Care	Cold - 40	105	0,61	47
Coulores	Cold - 60	85	1,00	56
Wool	Cold - 30	40	0,15	50
Quick	WIT	36	0,48	38
Rapid 15	Cold - 40	3	0,10	32
15 °C Wash	Cold - 60	15	0,22	45
Sports Wear	Cold - 40	105	0,62	42
Shirts	WIT	65	0,60	44
Bedding	-	85	0,30	50
Rinse	-	15	0,05	58
Spin	-	68	0,08	-
Drain	-	105	0,02	-

\* : Programme duration, Energy and Water Consumption are given for the cycles for programmes are started in set temperature.

WIT: Water Inlet Temperature

- : Programmes do not take water

- Temperature may vary depending on the heating time
- Durations may vary according to wash load (weight and type), tap water and ambient temperature and selected extra functions.

### 5.4. Program Details with Half Load Defection

Full Load / Half Load	Programmes	Programme Set Temperature	Available Temperature	Program Duration (min)*	Energy (kwh)*	Water Consumption (L)
Full Load	Cotton Eco	40	Cold - 60	125	0,98	74
	Cotton Eco	60	Cold - 60	200	1,19	50
Half Load	HL Cotton Eco	40	Cold - 60	102	0,62	42
	HL Cotton Eco	60	Cold - 60	165	0,66	42

## 5.5. Child Lock

### Activation

1. Press the fourth function button for 4-5 seconds.



2. The Child Lock Symbol is appeared on the LCD display.

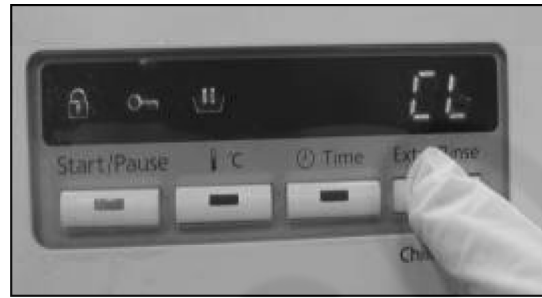

### Deactivation

1. Press the fourth function button for 4-5 seconds.



2. The Child Lock Symbol is deleted on the LCD display.



# 6 Test Mode

## 6.1. Autotest

1. After selecting spin speed to max, select the program 3 (Cotton Eco)



2. While pressing Extra Rinse button, change position of the third to second, and release the Extra Rinse button immediately.

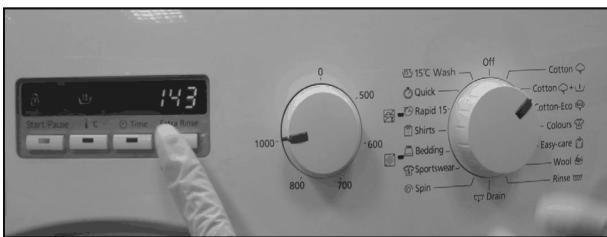

3. Autotest starts.



AUTOTEST													
	5	10	15	20	25	30	35	40	45	50	55	60	65
Time in seconds (to be adjusted)													
Entering autotest													
Changing power to 220 50Hz													
Main Voltage 50 Hz													
Door Lock Powered (Depends on door lock)													
Motor Ramp to max spin (max. is 15 sec.)													
Time until motor is stopped (Depends on the motor stop time)													
Motor Preferred Run (Direction to Right)													
Motor Inverse Run (Direction to Left)													
EV1 (flowrate dependent of washer)													
EV2 (flowrate dependent of washer)													
Test stopped until E.Rinse button is pressed (symbol blinking)													
EV1 + EV2 valves up to first level frequency (Depends on the water level) (if machine is a hot water one, take water from Hot Valve)													
NTC check													
Heather resistance													
Pump													
EPS measurement													
End Visualization													

**Ntc detection:** Software will detect NTC's resistance value and will check if the temperature is between 5°C < Temperature detected < 40°C. If it is inside the range, heating step will be done. If temperature value is outside the range, then it means NTC is detecting the temperature in a wrong way and heating step will be skipped.

**EPS measurement:** It checks the EPS and if it OK, it continues the autotest; if it is Not OK then cancel the Autotest and go to the selection mode. Also if any frequency can not be detected, then it means there is problem with connection or EPS, so it gives E10 which is EPS error and cancels the autotest & goes to the selection mode.



# 7 Service Mode

## 7.1. Service Autotest

1. Set program knob at Cotton Eco after selection spin speed to max.
2. While pressing the T °C button, change position of the third to second, and remove the T °C button within 1 second.

During test [SAU] is visualized on display :

LD1 Start / Pause Button LED → ON  
 LD9 Door Lock LED → ON (in a 30 sec)  
 Display → [SAU]

	Selector Cotton	Selector Cotton Prewash	Selector Cotton Eco
	Result	Result	Result
	HEATER ON	PUMP ON	TEST PROGRAM ON
Comments :	When entering in service test, door will be locked.		Test is over Door will be unlocked, machine will go to ENS state.

The test steps are as below ;

### Step 1 :

- Selector Cotton will be [HEATER ON]
- Before heating it should take water till first level frequency then start heating.
- Heater will be on max. 8 minutes after this 8 minutes if the temp. doesn't change more than 2 °C then it will give NTC failure. (E05).
- Or if the NTC connection is broken then it should give again E05 NTC failure.
- At the end of heating, [SAU] visualization should make slow blink to indicate that the step is over.
- Note : If user changes the selector position, machine will do what is defined for the new selected position.

### Step 2 :

- Selector Cotton with Prewash will be [PUMP ON]
- Temperature will be measured, if it is higher than 50 °C, it should take 60 sec. cooling water, and then make [Drain + 5 sec.]
- At the end of pump activation, [SAU] visualization should make slow blink to indicate that the step is over.

### Step 3 :

- Selector Cotton Eco will be 15 minutes test program.
- So, time for selector position 3 is 15 minutes.
- At the end of 15 minutes test program [END] is visualized and door is unlocked. During test pressing other buttons makes no change.
- LD1 Start / Pause button LED → ON  
 LD9 Door Lock LED → When the door is unlocked it will be off  
 Display → [END]

### 15 Minutes Test Program

- Total water consumption : 30 L (14L Main Wash, 16L Rinse)
- Total duration : 15 min. (8 min Main Wash, 7 min Rinse)
- Total 53 r/min motor movement : 6.5 min. (4.5 min Main Wash, 2 min Rinse)
- Heating : 1,5 min during Main Wash
- Spinning :  
 400 r/min (After Main Wash)  
 800 r/min (After Rinse)
- Number of Rinses : 1

## 7.2. Failure Codes

Error Indication	Error Number	Indication For User	Indication For Service
		Yes/No	Yes/No
Door is not locked	E01	Yes	Yes
Door is unlocked during programme	E01	Yes	Yes
Lack of water	E02	Yes	Yes
Pump failure	E03	Yes	Yes
Overflow	E04	Yes	Yes
NTC or Heater Failure	E05	No	Yes
Motor Failure - 1 (Tachometer open-short circuit or motor connector is disconnected)	E06	No	Yes
Motor Failure - 2 (triac short circuit)	E08	No	Yes
Electronic Pressure Sensor	E10	No	Yes

## 8 Troubleshooting Guide

All repairs which must be done on the machine should be done by authorized agents only. When a repair is required for machine or you are unable to eliminate the failure with the help of the information given below:

- Unplug the machine.
- Close the water tap.

FAILURE	PROBABLE CAUSE	METHODS OF ELIMINATION
<b>Machine does not operate.</b>	It is unplugged.	Insert the plug into the socket.
	Fuse is defective.	Change fuse.
	Start / Pause button has not been pressed.	Press the start / pause button.
	The program knob is in 0 (off) status.	Bring the program knob on the desired status.
	The door is not shut properly.	Shut the door properly. You should hear the click.
	Child lock is active.	Refer to 5.5. Child Lock.
<b>Machine does not receive water.</b>	Water tap is closed.	Open water tap.
	The water inlet hose may be bent.	Check the water inlet hose.
	The water inlet hose is obstructed.	Clean the filters of water inlet hose.
	The water inlet filter is obstructed.	Clean the valve inlet filters.
	The door is not shut properly.	Shut the door properly. You should hear the click.
<b>Machine is not draining water.</b>	The drain hose is obstructed or bent.	Check the drain hose.
	The pump filter is obstructed.	Clean the pump filter.
	The clothes are not placed inside the machine in a well-balanced manner.	Spread the clothes inside the machine in an orderly and well-balanced manner.
<b>Machine is vibrating.</b>	The feet of machine are not adjusted.	Adjust the feet.
	Transportation screws are not removed.	Remove transportation screws.
	There is a small amount of clothes in the device.	It does not prevent operation of the machine.
	Excessive amount of clothes are filled in the machine or the clothes are not placed in a well-balanced manner.	Do not exceed the recommended quantity of clothes and spaced clothes in the machine in a well-balanced manner.
<b>Excessive foam in the detergent drawer</b>	Too much detergent has been used.	Press the start/pause button. In order to stop the foam, dilute one table-spoon of softener in half liter of water and pour it in the detergent drawer. Press the start/pause button after 5-10 minutes. Arrange the amount of the detergent properly in the next washing process.
	Wrong detergent has been used.	Use only the detergents produced for full automatic machines.
<b>The washing result is bad.</b>	Laundry too dirty for the program you have selected.	Select a suitable program.
	The amount of detergent used is not sufficient.	Use more detergent according to the detergent.
<b>The washing result is not good.</b>	Clothes exceeding the maximum capacity has been filled in machine.	Put the clothes in machine in a manner not to exceed its maximum capacity.
	Water may be hard.	Use the amount of detergent according to the declaration of the detergent producer.
	Distribution of the clothes in machine is not well-balanced.	Spread the clothes inside the machine in an orderly and well-balanced manner.
<b>The water is seen in the drum during washing.</b>	No failure. The water is at the lower part of the drum.	
<b>There are residues of detergent on the clothes.</b>	The pieces of some detergents which do not dissolve in water may stick to clothes as white stains.	By calibrating machine for [Rinsing] program, make an additional rinsing or eliminate the stains After drying with the help of a brush.
<b>There are grey stains on the clothes.</b>	These stains may be caused by oil, cream or ointment.	In the next washing operation, use the maximum detergent amount declared by the detergent producer.
<b>The spinning process is not done or starts with delay.</b>	No failure. The unbalanced load control works in that way.	The unbalanced load control system will try to distribute clothes in a homogenous manner. After clothes are distributed, passage to spinning process will be realized. In the next washing process, place clothes into the machine in a well-balanced manner.

# 9 Disassembly and Assembly Instructions

## 9.1. Torque Values

ASSEMBLY LOCATION	PART NAME	SAP CODE	TORQUE MIN. (Nm)	TORQUE NOM. (Nm)	TORQUE MAX. (Nm)
Parazit Filter - Cabinet Assembly	ISO 7049 ST 4.2X9.5 R Underhead Serrated	35001817	2,34	2,60	2,86
Pressure Switch Supporting Plastic - Cabinet Assembly	SCREW 4X12 PAN HEAD WITH COLLAR UNDER HEAD SERRATED	37013513	1,44	1,60	1,76
Hinge - Cabinet Assembly Without Hing Support Sheet	SCREW TT M4X8 PAN HEAD CROSS RECESS	35007417	1,40	1,65	1,90
Speed Control Hole Tapper - Cabinet Assembly	ISO 7049 ST 4.2X9.5 R Underhead Serrated	35001817	1,50	1,50	1,60
Spring Supporting Sheet - Cabinet Assembly	ISO 7049 ST 4.2X9.5 R Underhead Serrated	35001817	1,98	2,20	2,42
Front Panel - Cabinet Assembly	ISO 7049 ST 4.2X9.5 R Underhead Serrated	35001817	2,30	2,40	2,80
Front Panel - Plint Assembly	ISO 7049 ST 4.8X9.5 R Underhead Serrated	37010108	2,40	3,50	3,70
Middle Support Braket - Cabinet Assembly	ISO 7049 ST 4.2X9.5 R Underhead Serrated	35001817	2,43	2,70	2,97
Control Panel - Front Panel Assembly	ISO 7049 ST 4,2x13 TYPE 2	37007273	2,43	2,70	2,97
Door Lock - Cabinet Assembly	ISO 7049 ST 4,2x16	35008931	1,10	1,60	1,70
Adjustable Foot	M10x1,25 6g	47000778	2,50	2,80	3,10
Top Support Sheet - Cabinet Assembly	ISO 7049 ST 4.2X9.5 R Underhead Serrated	35001817	2,43	2,70	2,97
Front Panel Drop Fixing Plastic	ISO 7049 ST 4,2x16	35008931	2,50	2,70	2,90
Mechanic Control Panel Program Knob Supporting Sheet MV1	SCREW 3.5X9 PAN HEAD WITH COLLAR CROSS RECESS	35007387	0,50	1,00	1,00
Mechanic Control Panel Program Knob Supporting Sheet MV2	SCREW 3.5X9 PAN HEAD WITH COLLAR CROSS RECESS	35007387	0,50	1,00	1,00
Detergent Drawer - Control Panel Assembly	SCREW 4X14 PAN HEAD TYPE 2	37007242	1,00	1,00	1,20
Detergent Drawer - Spring Supporting Sheet Assembly	ISO 7049 ST 4,2x16	35008931	1,44	1,60	1,76
Drum Group Type A	COUNTERSUNK HEAD BOLT M6X22 TORX INOX	37000513	13,00	14,00	16,00
Transport Screw Assembly	TRANSPORT SCREW GROUP 2	37009655	6,50	6,50	7,00
Motor Assembly	COUNTERSUNK HEAD BOLT 8X28 TORX	37007899	6,00	6,50	7,50
Front Concrete Weight - Front Tub Assembly	HEXAGON HEAD BOLT 10X52	35007415	17,50	18,00	19,00
Upper Counter Weight Assembly	MUSHROOM HEAD SQUARE NECK BOLT M 8X65 WITH M8 NUT	37003063	25,00	27,50	30,00
Pulley - Drive Shaft - Washing Group Assembly	COUNTERSUNK HEAD BOLT M 8X29	37005142	39,50	40,00	40,50
Drum Wrapper Sheet-Plastic Lifter Assembly	SCREW 4X14 PAN HEAD INOX	37007086	0,90	1,00	1,10
Front Tub - Rear Tub Assembly	HEXAGON HEAD BOLT 6x30 PT	37014521	4,50	4,70	5,00
	HEXAGON HEAD BOLT 6x30 DELTA PT	37008870	5,00	5,25	5,50
Motor Cover Assembly	THREAD ROLLING SCREW M4X12 PAN HEAD TORX	35008716	1,10	1,20	1,30
Front Tub- Resistance Protection Foil 1	SCREW 3,5X7 PAN HEAD WITH COLAR CROSS RE.	37015637	0,60	0,75	0,90

## 9.2. Top Plate

1. Remove two screws that fix the top-plate at the back.



2. Push the top-plate back and pull it up.

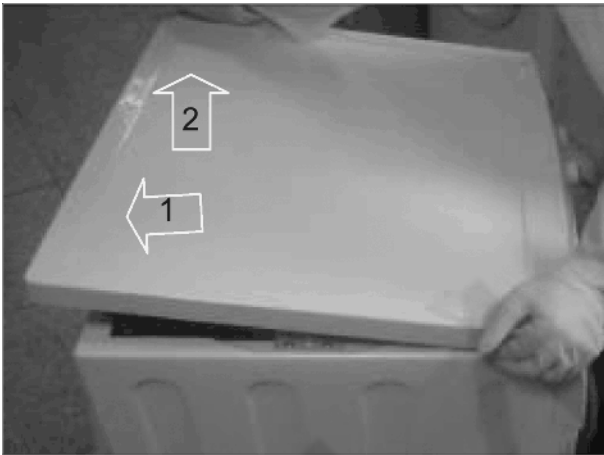

## 9.3. Door

1. Remove two screws that fix the door. (by using the T25)



T25



2. Pull the door up.



3. Remove screws that fix the door group.



4. Put the door outside plastic with helping screwdriver as it is shown in the picture.



5. Remove the door inside plastic as it is shown in the picture.



6. Remove six screws that fix the door hinge as it is shown in the picture.



7. Remove the door handle as it is shown in the picture.



8. Remove the door handle pin as it is shown in the pictures.



## 9.4. Spring Wire

1. First remove the spring wire fixing the tub bellows seal by using the small size screw driver.  
Pull the tub bellows seal as it is shown in the picture.



2. Remove the tub bellows seal-body fixing spring.



## 9.5. Detergent Drawer

1. Remove the detergent drawer and pull it up carefully.



## 9.6. Control Panel

1. Remove the screw which fix the control panel to the front panel.

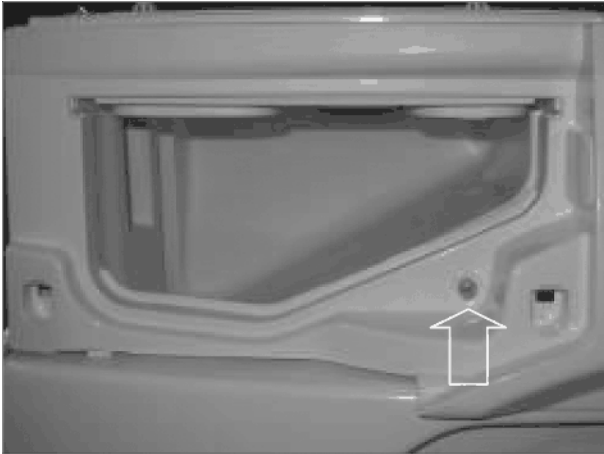

2. Remove three screws fixing the control panel.

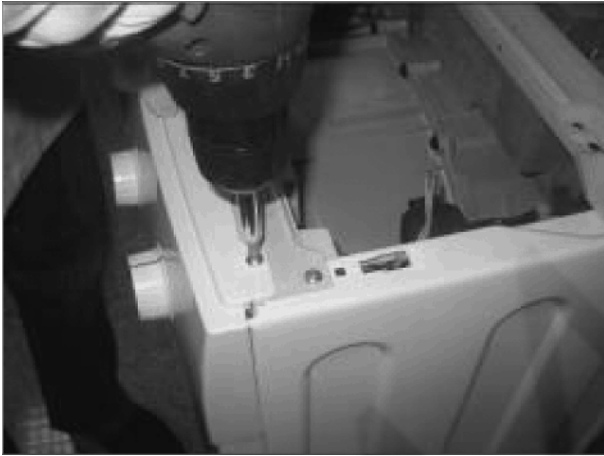

3. Pull the control panel up.



4. Remove connectors as it is shown in the picture.



5. Remove electronic card cover as it is shown in the pictures by using small screw driver.

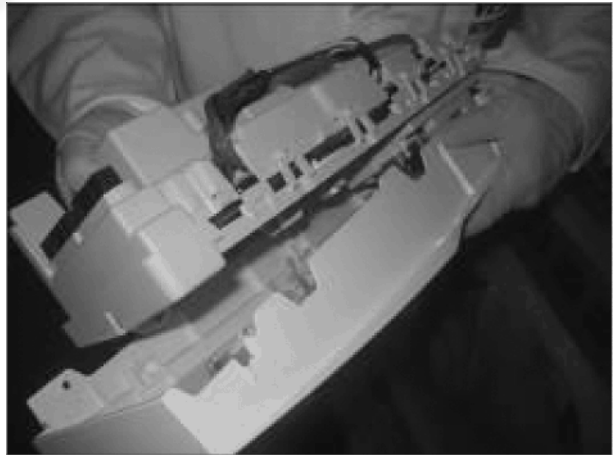



## 9.7. Kick Plate

1. Remove the right part of the kickplate as it is shown in the picture.



2. Remove two screws fixing the kickplate.



3. Pull the kickplate left and push it down.

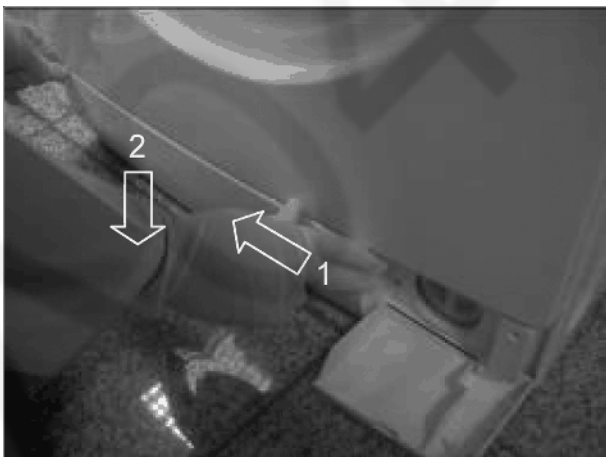

## 9.8. Front Panel

1. Remove two screws fixing the front panel at the bottom as it is shown in the picture by using T25.



2. Remove two screws fixing the door lock as it is shown in the pictures.



3. Remove the tub bellows seal as it is shown in the pictures.



4. Remove two screws fixing front panel at the upper as it is shown in the picture.



5. Remove the front panel as it is shown in the pictures.



## 9.9. Upper Support Bracket

1. Remove two screws fixing the body group at the front as it is shown in the picture.



2. Remove two screws fixing the body group at the upper as it is shown in the picture.



3. Remove detergent drawer group two clips fixing the upper support bracket as it is shown in the picture.



## 9.10. Detergent Drawer Housing

1. Remove the tub seal clamp by using the pliers, which is attached to the detergent drawer housing.



2. Remove the four connectors that is connected to the feed valve as it is shown in the picture.

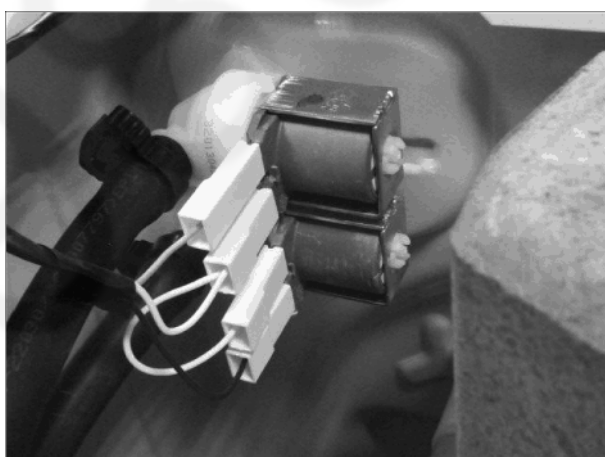

3. Turn the feed valve counter clockwise slightly to remove.



4. Remove the detergent drawer housing assembly.



3. Pull the power cable group up as it is shown in the picture.

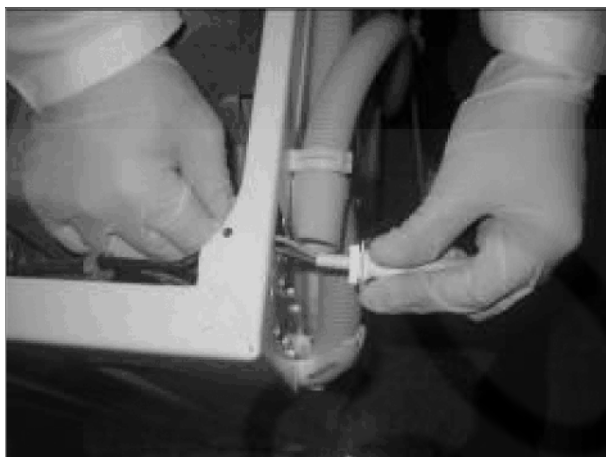

## 9.11. Power Cable Group and Parasite Filter

1. Remove the five connectors that is connected to the parasite filter.



2. Remove two screws fixing the parasite filter.



4. Remove parasite filter fixing body group as it is shown in the picture.



## 9.12. Electronic Pressure Switch (EPS)

1. Remove the connector that is connected to the EPS.

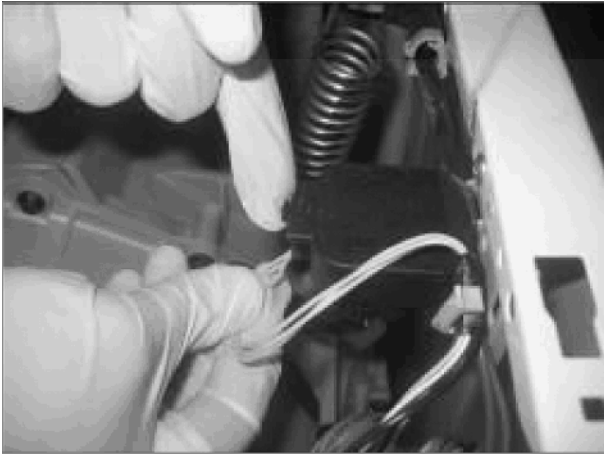

2. Pull the EPS upward to remove as it is shown in the picture.

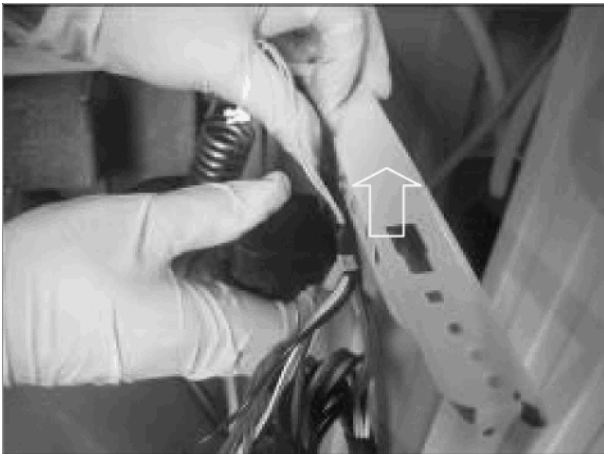

3. Remove the EPS hose handcuffs and EPS hose as it is shown in the picture.



## 9.13. Door Lock

1. Remove the connector that is connected to the door lock.

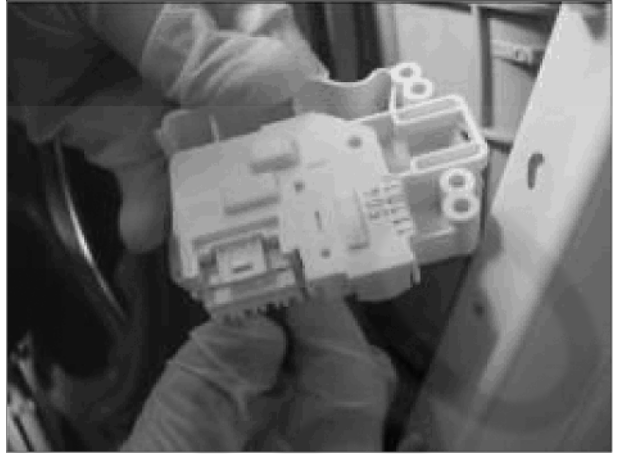

## 9.14. Pump Motor

1. Remove pipe clip that fixes the drain hose.



2. Remove pipe clip fixing the tub outlet hose.



3. Remove the connector that is connected to the pump motor.



4. Remove four screws fixing the pump motor.



## 9.15. Front Counterweight

1. Remove four screws fixing the front counterweight on the front. (Box wrench size 13 mm)



2. Pull the counterweight back.



## 9.16. Heater

1. Remove the four connectors that is connected to the heater.



2. Remove one nut fixing the heater slightly (box wrench size 8 mm)



2. Hold the tub bellows seal and gasket-body fixing spring together, and pull them up.



3. Hold the heater and pull it out.



### 9.18. Transport Screw

1. Remove four transport screws. (box wrench size 10 mm)



### 9.17. Tub Bellows Seal

1. Remove the tub gasket clip by using small screwdriver.



2. Hold the transport screw and pull it out.





## 9.19. Upper Counterweight

1. Remove two screws fixing the upper counterweight by using box wrench size 13 mm.



2. Remove the upper counterweight.



2. Cut the five lead wire holders as shown the pictures.

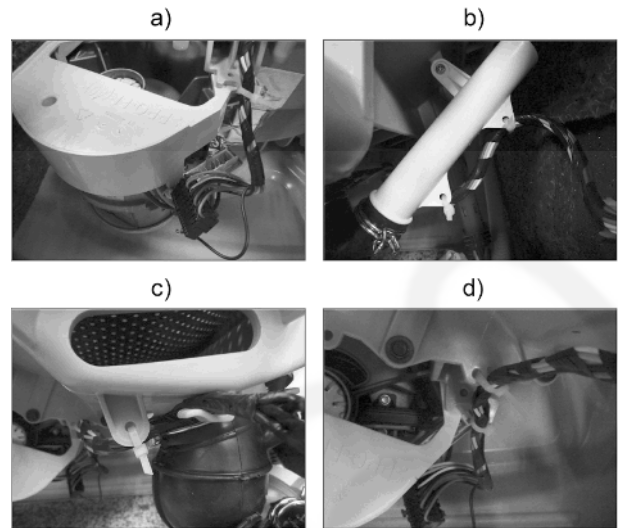

3. Remove the four screws fixing the spring hanger sheet iron.



4. Remove the washing group as it is shown in the picture.

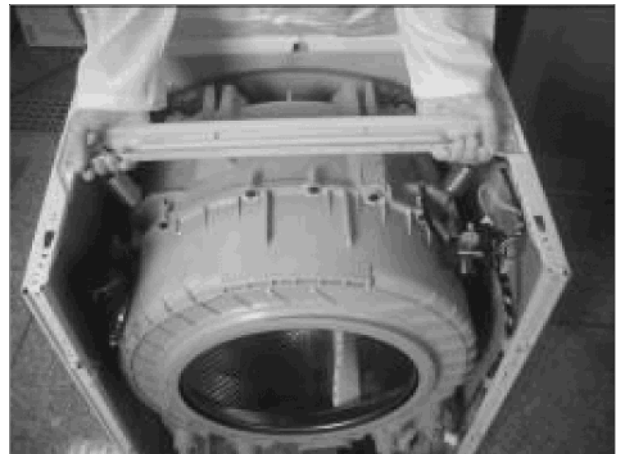

## 9.20. Washing Group

1. Remove the connector that is connected to the motor.





### 9.21. Shock Absorber PIN

1. Remove two pins fixing the shock absorber as shown in the picture.

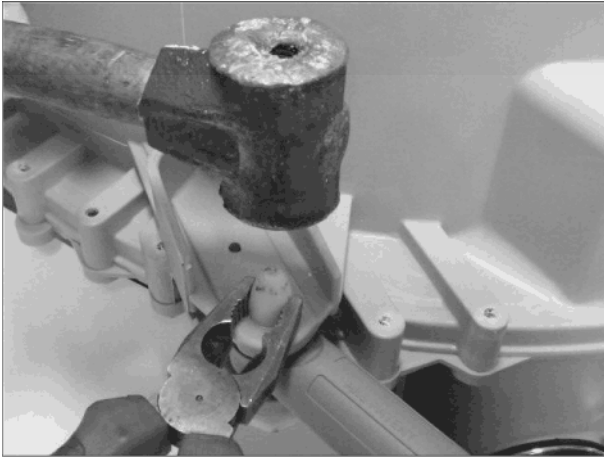

2. Remove the driven pulley it is shown the picture.



### 9.22. Belt

1. Remove the belt as it is shown the picture.



### 9.24. Motor

1. Remove the four screws fastening the motor under the tub by using T40.



2. Pull the motor up for disassembly.

### 9.23. Driven Pulley

1. Remove the screw fixing driven pulley it is shown the picture (By using T40).



### 9.25. Tub Entrance with Bellow Hose

1. Remove the tub entrance with bellow hose.



### 9.27. Tub

1. Remove nineteen screws fixing tub using box wrench size 8 mm.



### 9.26. Pressure Switch Hose Group

1. Remove screw fixing the pressure switch water reservoir.



2. Remove the tub exit with bellow hose with ball by using box wrench size 10 mm.



### 9.28. Drum

1. Remove the drum.



# 10 Measurements and Adjustments

## 10.1. Drain Pump

Drain pump is both a mechanical and electrical component which is used to drain water inside the washing machine. It has an synchronous motor inside. For better performance maintenance, pump filter should be cleaned regularly.

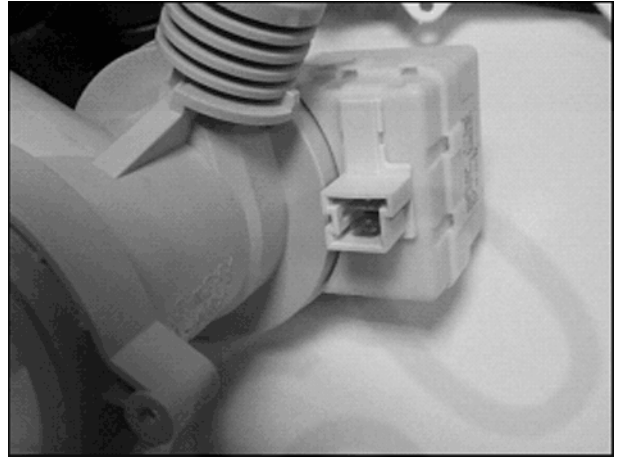
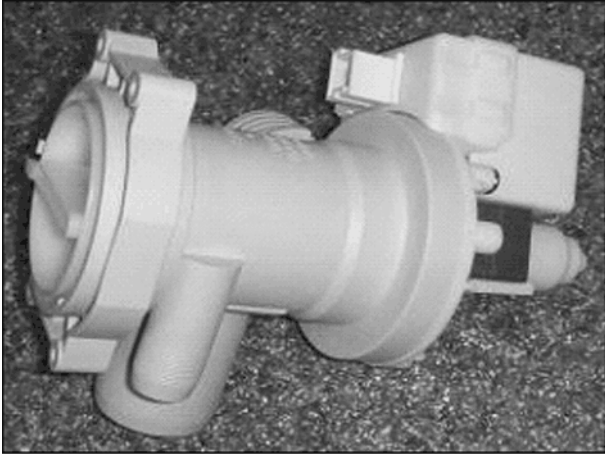

### 10.1.3. Component Controlling By Connection Measurement

#### 10.1.1. Technical Features

Nominal voltage	220 - 240 V
Nominal current	0.28 A ( $\pm 10\%$ )
Nominal power	37 W
Frequency	50 Hz
Resistor (coil)	136 $\Omega$ ( $\pm 5\%$ )
Water flow:	17 L/min (to 1 m height)
Thermal protector	YES

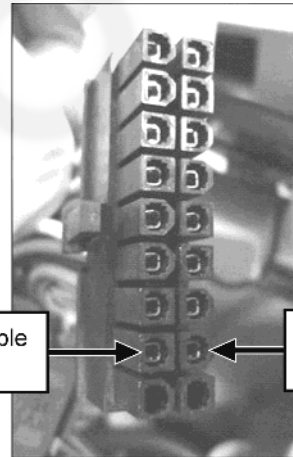

Blue Cable at 11th

Blue Cable at 2nd

#### 10.1.2. Checking of Component

Check the resistance value on the component with multimeter as shown in belows figures.

Resistance value should be between 131 - 141  $\Omega$ .



Checking the component

You can determine the ohm value by measuring from the blue cable at 2nd and blue cable at 11th position in the large socket (refer to 12 Wiring Connection Diagram) as shown in belows figures.

Resistance value should be between 131 - 141  $\Omega$ .

## 10.2. Resistance

Heating element (Resistance) is a component which is designed to regulate temperature of water inside the drum. It has three connections: Phase, notral and ground connections.

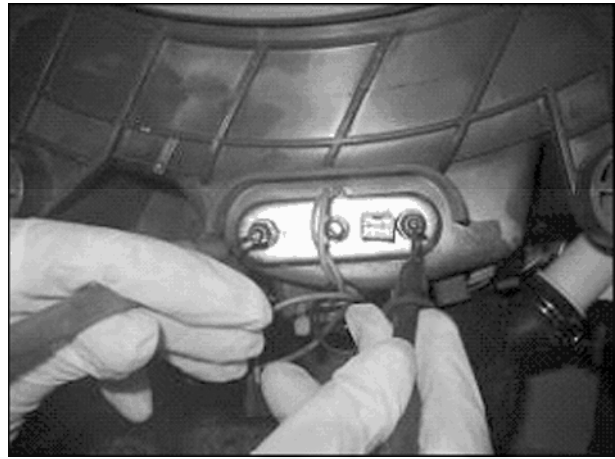
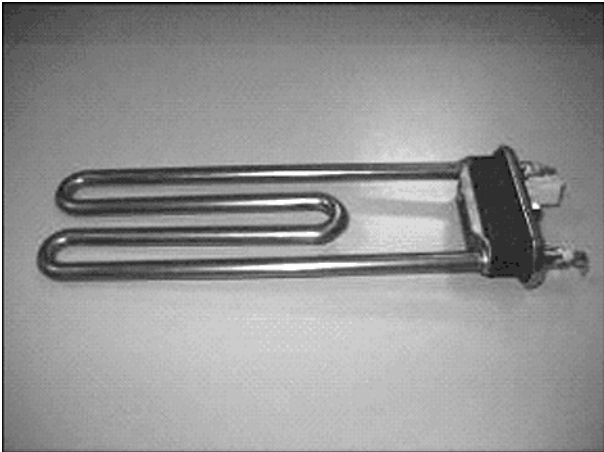

### 10.2.3. Component Controlling By Connection Measurement

#### 10.2.1. Technical Features

Kind of heating	Tubular heating element with NTC - sensor
Nominal voltage	230 V
Nominal power	2000 W ( $\pm 5\%$ )
Resistance	$24,8 \pm 5\% \Omega$
Thermal fuse	2 - sided

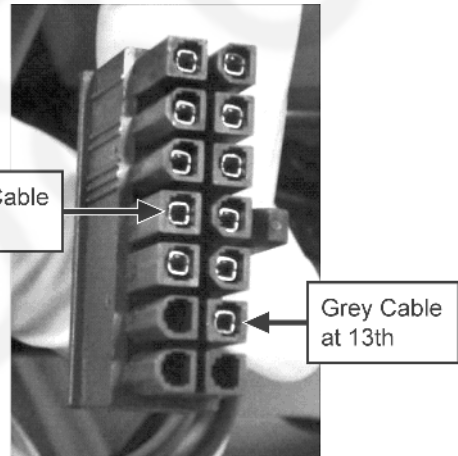

#### 10.2.2. Checking of Component

Check the resistance value on the component with multimeter as shown in below pictures.



Checking the component

You can determine the ohm value by measuring from the grey cable at 13th and brown cable at 4th position in the small socket (refer to 12 Wiring Connection Diagram) as shown in belows figures.

Resistance value should be between 23 - 27 Ohm.

### 10.3. NTC

Component which sends signals to PCB about the water temperature inside the tub.

The Resistance (Ohm) value of the NTC decreases as the temperature increases.



### 10.3.2. Checking of Component

Check the resistance value on the component with multimeter as shown in below pictures.

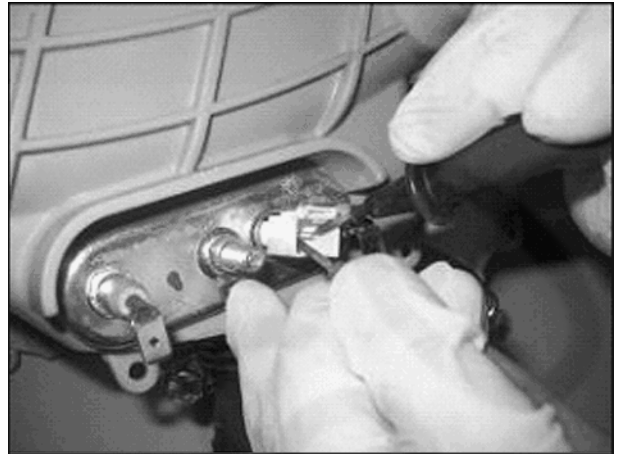

Checking the component



### 10.3.1. Technical Features

NTC Tempure - Resistance Values

Tem (°C)	R min (kΩ)	R max (kΩ)
-10	54,9	62,6
-5	43,0	48,6
0	33,9	38,1
5	27,0	30,1
10	21,6	23,9
15	17,4	19,1
20	14,1	15,4
25	11,5	12,5
30	9,4	10,2
35	7,8	8,3
40	6,4	6,9
45	5,4	5,7
50	4,5	4,7
55	3,8	3,9
60	3,2	3,3
65	2,7	2,8
70	2,3	2,4
75	1,9	2,0
80	1,7	1,8
85	1,4	1,5
90	1,2	1,3
95	1,1	1,1
100	0,9	1,0

### 10.3.3. Component Controlling By Connection Measurement

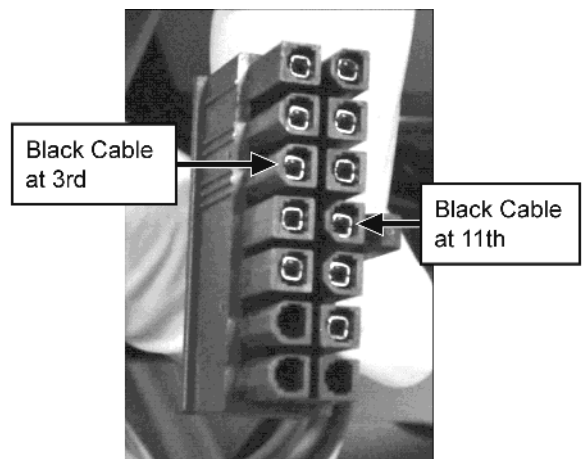

You can determine the ohm value by measuring from the black cable at 3rd and black cable at 11th position in the small socket (refer to 12 Wiring Connection Diagram) as shown in belows figures.

NTC resistance value varies depending on temperature.

## 10.4. Valve

Valve is an electrical and mechanical component which is designed to take water from the network system into the wash-machine. It is operated by PCB card.

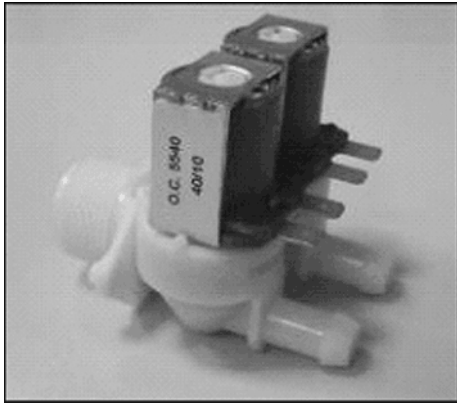

### 10.4.1. Technical Features

Nominal voltage	220 - 240 V
Nominal power	8 VA
Frequency	50-60 Hz
Rated flow:	7 L/min ( $\pm 15\%$ )
Operating water pressure	0.03 - 1 Mpa

### 10.4.2. Checking of Component

Check the resistance value on the component with multimeter as shown in below pictures.

Valve water flow rate should be between 6 L/min - 8 L/min.

Each valve bobbin resistance values should be between 3,3 - 4.2 kohm.



Checking the component



### 10.4.3. Component Controlling By Connection Measurement

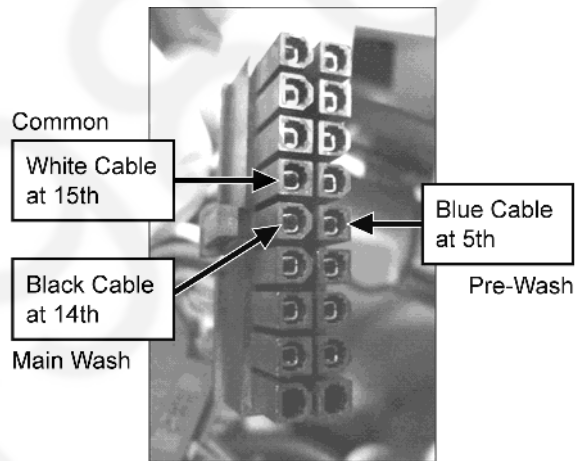

You can determine the ohm value of the main wash valve by measuring from the blue cable at 5th and white cable at 15th position or the pre-wash valve by measuring from the black cable at 14th and white cable at 15th position in the large socket (refer to 12 Wiring Connection Diagram) as shown in belows figures.

Each valve bobbin resistance values should be between 3,3 - 4.2 kohm.



## 10.5. Electronic Pressure Switch (EPS)

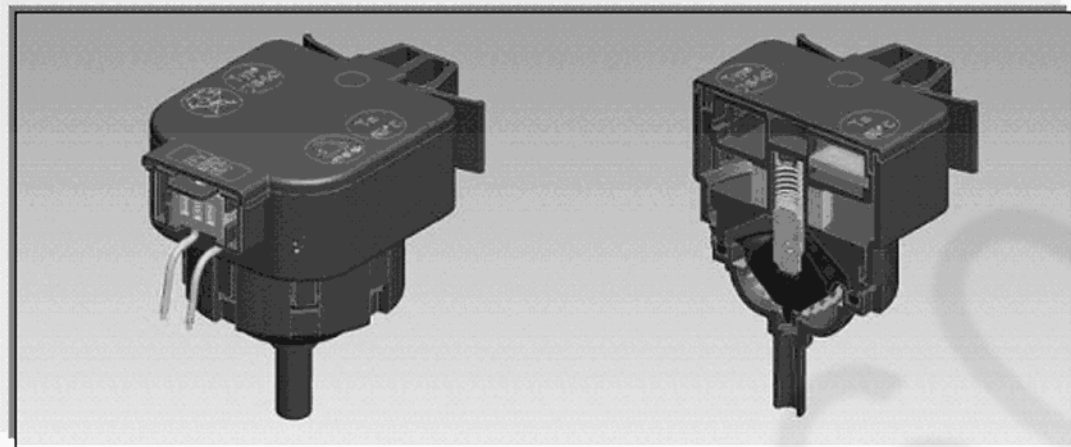

### 10.5.1. Technical Features

Electromagnetic field occurs as a result of the vibration of the membrane which is under pressure in the coil. The nucleus part is moved up and down by the electromagnetic field. The water level is regulated by the frequency which is controlled by the PCB and changes according to the movement of the nucleus part.

### 10.5.2. Checking of Component

1. Push the door lock slider with screwdriver.



2. Select the 1st program and start the machine.



3. Cut off the energy input when the water intake finishes and drum begins to rotate.



4. Check the water level inside the drum with ruler. It should be 10 cm  $\pm$ 1.



## 10.6. Motor (For NA-107VC4)

The washing machine has an asynchronous motor. It is controlled by the PCB.

It is essential to check the motor for correct diagnosis and quick servicing. In the below picture, socket points on the motor is shown to measure with multimeter.

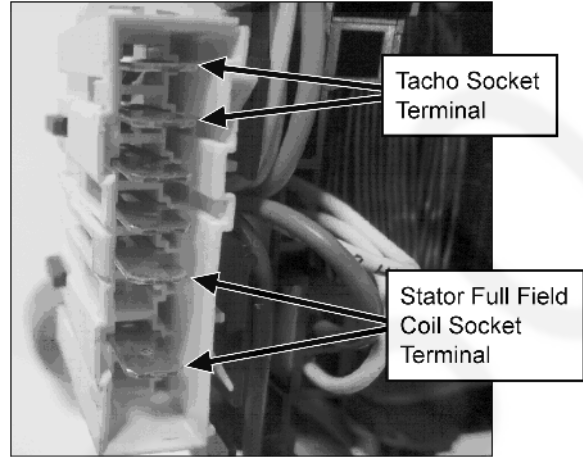
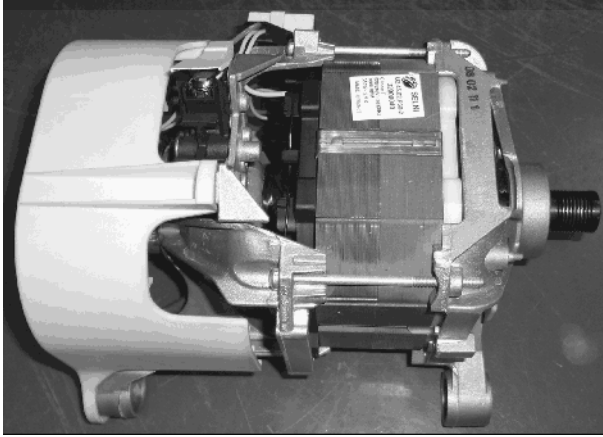

Motor Socket Terminals

Tacho and stator (full field-half field) ohm resistance values for the motor types are listed in the below table.

Resistance values for the motor types

MOTOR CODE	SUPPLIER	STATOR (FULL FIELD) (ohm)	TACHO (ohm)	TEMPERATURE
32017607	SELNI	1.15 $\Omega$ $\pm$ 0,07	87,7 $\pm$ 10	20 °C - 25 °C

### 10.6.1. Resistance Controlling By Connection Measurement (Tacho)

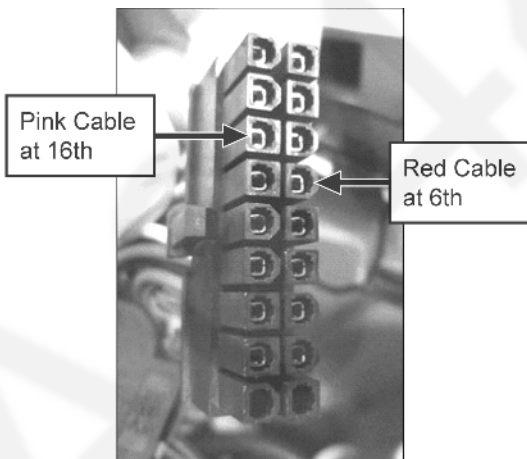

You can determine the ohm value by measuring from the pink cable at 16th and red cable at 6th position in the large socket (refer to 12 Wiring Connection Diagram) as shown in belows figures. For resistance values, refer to the table.

### 10.6.2. Resistance Controlling By Connection Measurement (Stator)

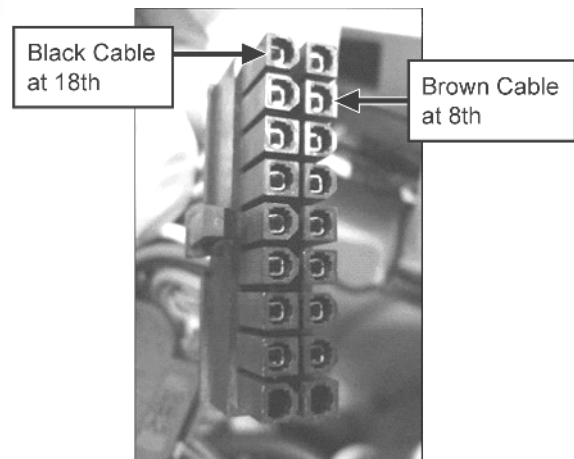

You can determine the ohm value by measuring from the brown cable at 8th and black cable at 18th position in the large socket (refer to 12 Wiring Connection Diagram) as shown in belows figures. For resistance values, refer to the table.



## 10.7. Door Lock

Door lock is activated at the beginning of the program in order to prevent the door from opening. Locking is generated by supplying power to PTC-bimetal, after max 6sec (220V), the bimetal will be warm and ready to close the contacts. Thus the first impulse to the solenoid will allow the contact to close and consequently the slider will be locked by the pin of the slider-lock. The second impulse causes no electrical and mechanical modifications. It can be unlocked by the third impulse; the contact is opened even if the PTC-bimetal remains energized.

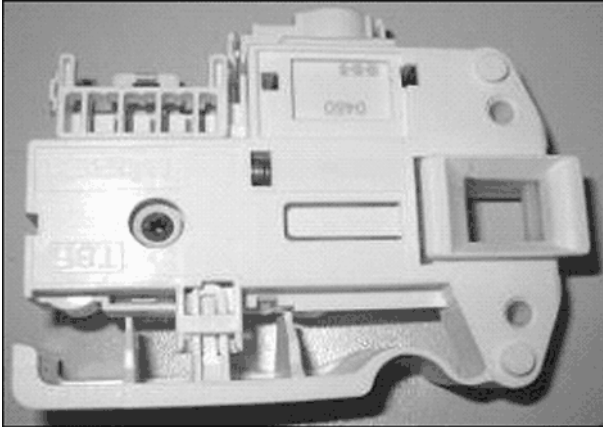

### Emergency Opening System (PTC-Bimetal) In Case of Lack of Electric Energy

- In case of lack of electric energy during a washing cycle, the PTC-bimetal assembly will cool down and after minimum 60 sec (considering previous power supply of 30 sec min and  $T=20\text{ }^{\circ}\text{C}$ ) the door will be unlocked and thus can be opened.
- In case the door is closed when current comes back, the PTC-bimetal assembly will heat again, the slider-lock will lock, the contact will close and the program will continue from where it stopped.

### 10.7.1. Technical Features

Nominal voltage	250 V
-----------------	-------

### 10.7.2. Checking of Component

Check the resistance value on the component with multi-meter as shown in below figures.

Resistance value on the (PTC overload + solenoid) should be  $240\Omega \pm 20\%$  at  $25\text{ }^{\circ}\text{C}$ . That resistance value can be measured from terminal 3-4 (refer to 12 Wiring Connection Diagram).

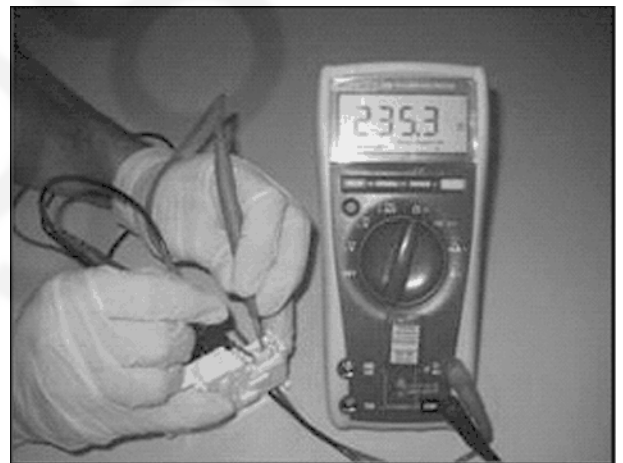
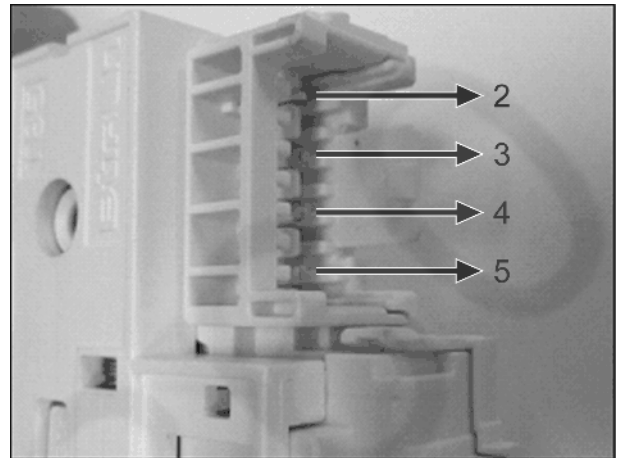

### 10.7.3. Component Controlling By Connection Measurement

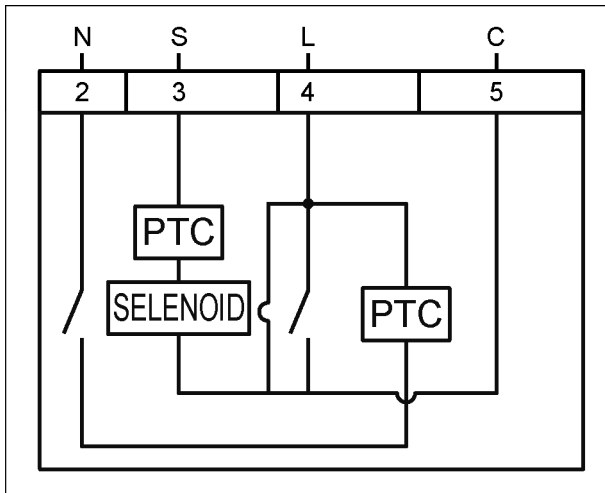

This socket shows the connection between terminal 3-4 (See wiring diagram (\*\*\*) above). The resistance read from terminal 3-4 is the resistance of PTC overload plus resistance of solenoid.

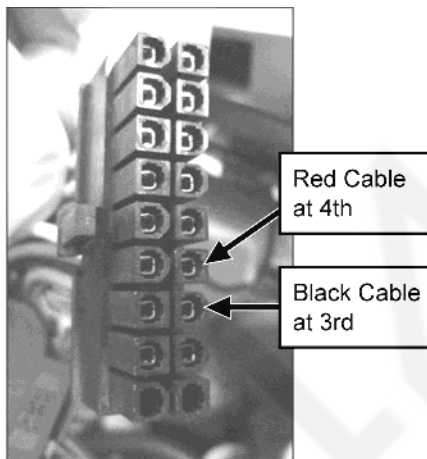

## 11 Dimensions

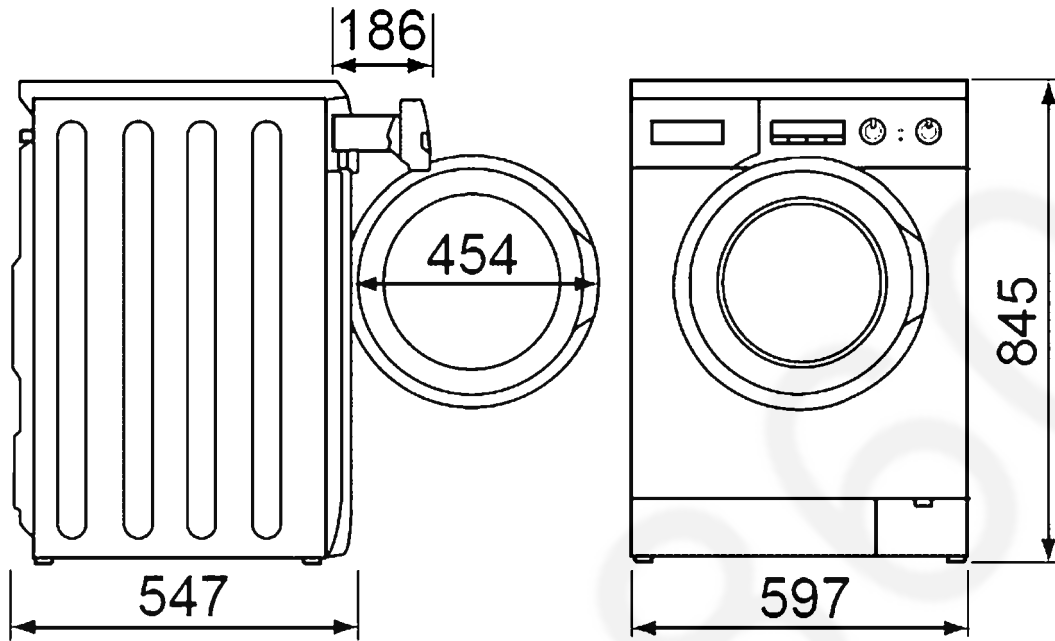

Dimension in millimetres  
NA-107VC4

# 12 Wiring Connection Diagram

## 12.1. Wiring Diagram NA-107VC4

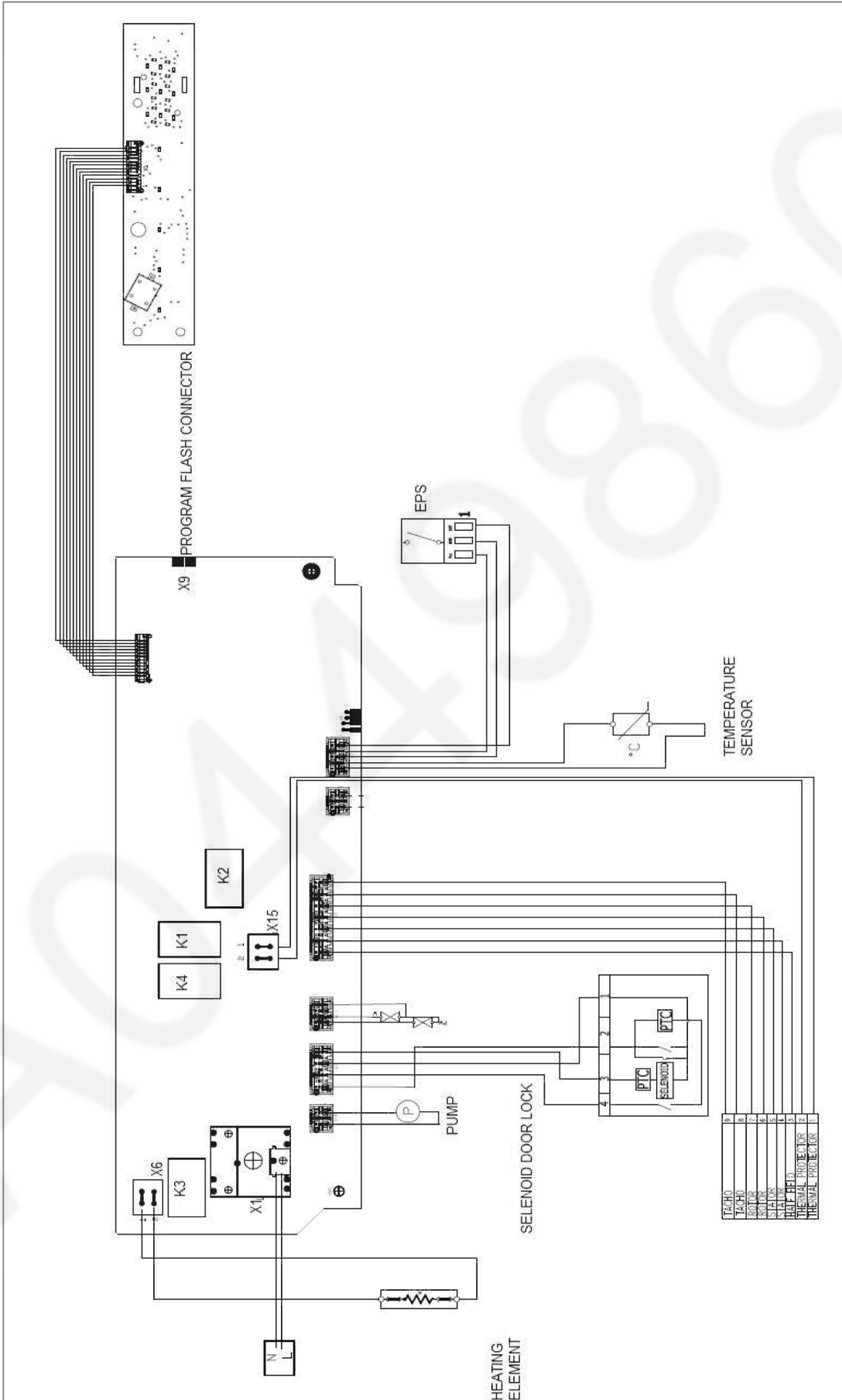

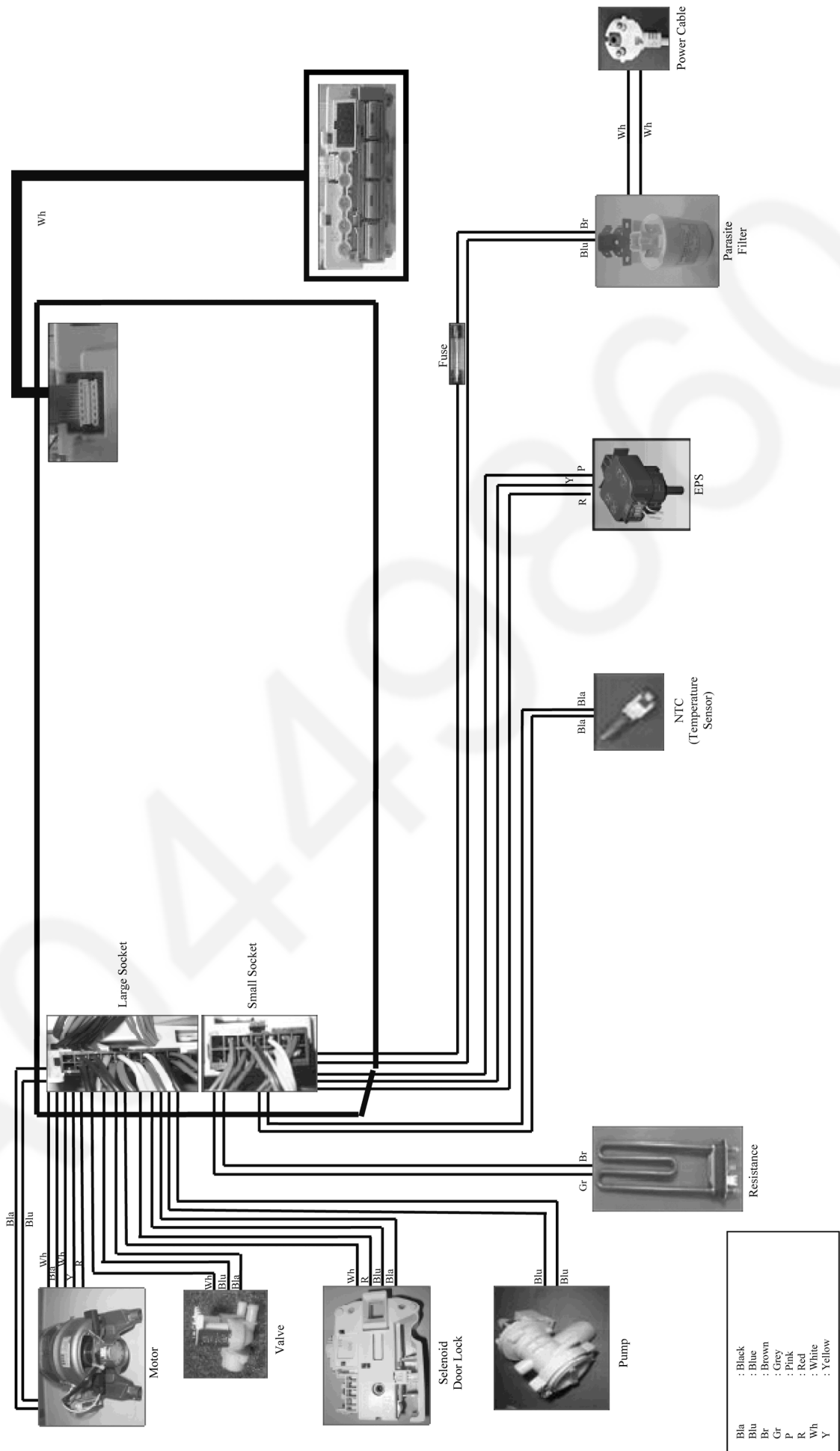

## 13. Exploded View and Replacement Part List

### 13.1. Control Panel Parts

#### 13.1.1. Exploded View Control Panel Parts

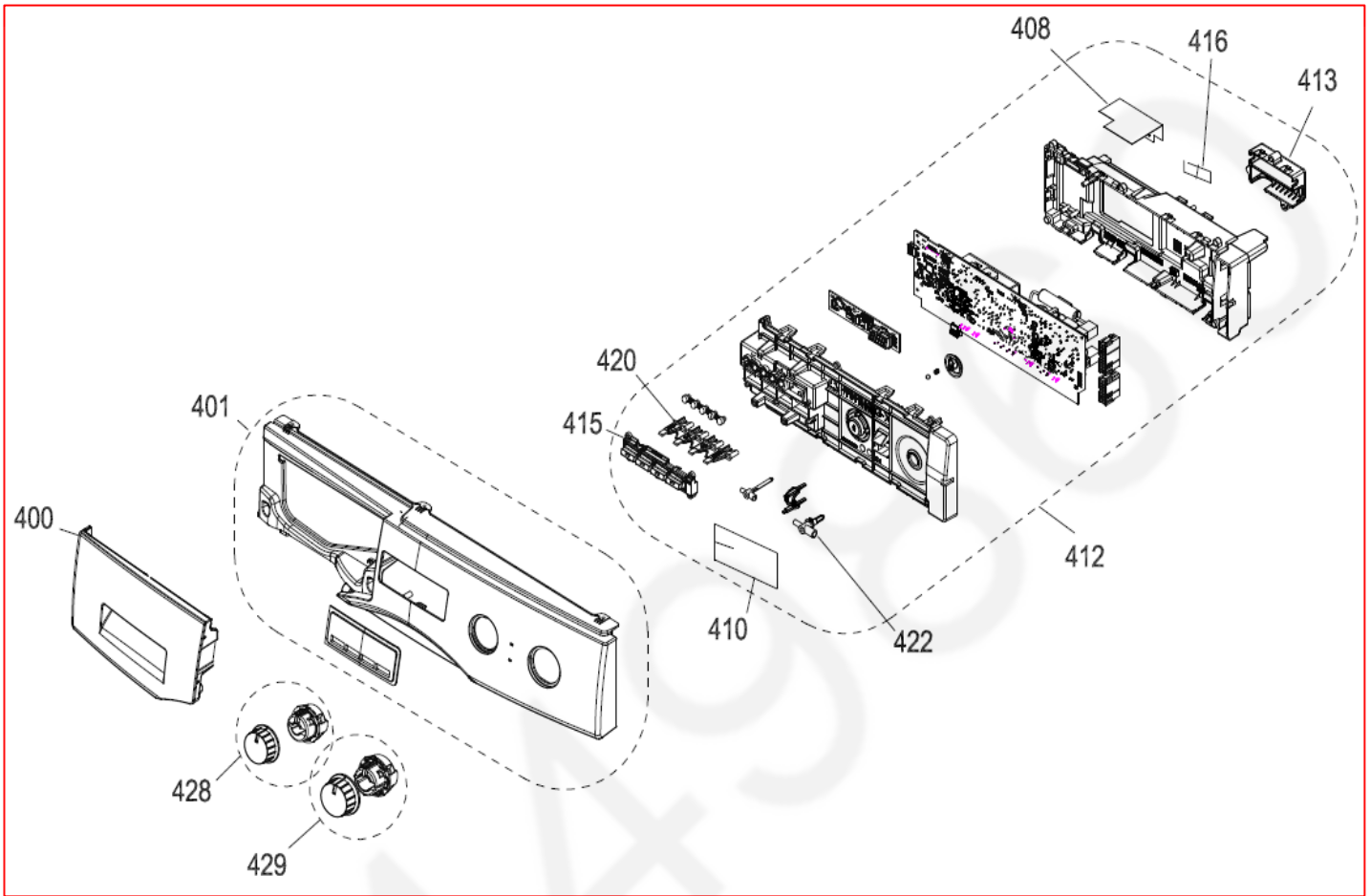

#### 13.1.2. Control Panel Replacement Parts List - A

(U) : Indicates parts at the remarks that can be replaced by user.

⚠ : Components identified ⚠ mark have special characteristics important for safety. When replacing any of these components use only manufacture's specified parts.

REF. NO	PART NAME	QTY	CODE	REMARKS
400	DETERGENT DRAWER COVER	1	AXWDV-769090	
401	CONTROL PANEL	1	AXWCV-769080	
408	PCB FOIL	1	AXW1FS-7092	
410	DISPLAY FOIL	1	AXW1FS-7315	
412	ELECTRONIC CARD GR.	1	AXW24V-67089	
413	CABLE AND FUSE FOLDER COVER	1	AXW2CF-55340	
415	SELECTION BUTTONS	1	AXW146-55880	
416	FUSE	1	AXW1FS-13553	⚠ 20 A
420	LIGHT GUIDE QUAD	1	AXW146-55333	
422	PROGRAM ADJ. SHAFT	1	AXW336-55341	
428	SPIN / HEAT ADJ. KNOB GR.	1	AXW6C-565960	
429	PROGRAM ADJ. KNOB GR.	1	AXW6C-565950	

## 13.2 Front Panel Parts

### 13.2.1. Exploded View Front Panel Parts

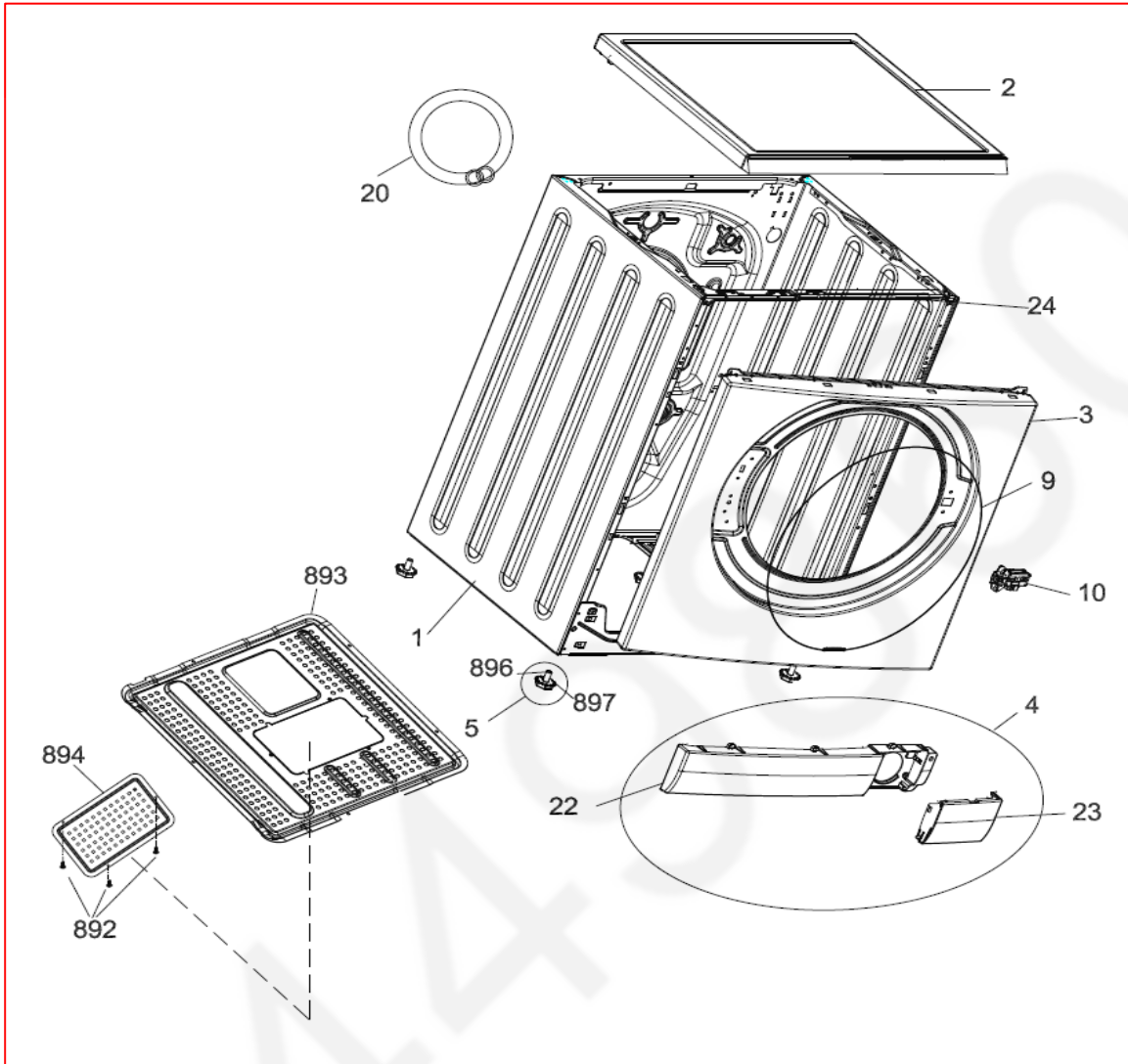

### 13.2.2. Front Panel Replacement Parts Part List

REF. NO	PART NAME	CODE	QTY	REMARKS
1	BODY GROUP PAINTED	AXW1AB-37787	1	
2	UPPER TRAY GROUP	AXW11N-07630	1	(U)
3	FRONT PANEL GROUP	AXW1BB-42790	1	
4	PLINTH GROUP	AXW22S-23758	1	
5	ADJUSTABLE FEET GR.	AXW31-00778	4	
9	HOUSING FRAM BELLOW CLIP-PHT	AXW1Z-08309	1	
10	DOOR LOCK	AXW1619-3597	1	⚠
20	WATER ENTRY HOSE GROUP	AXW12C-14423	1	
22	PLINTH	AXW130-23756	1	
23	PLINTH COVER	AXW140-23757	1	(U)
24	UPPER SUPPORT BRACKET	AXW1US-70732	1	
892	SCREW TT M4X8 PAN HEAD CR	AXWSCR-07417	3	
893	BOTTOM PLATE	AXWBP-172050	1	
894	BOTTOM PLATE COVER	AXWBP-172060	1	
896	SCREW M10X30	AXWSCR-01322	4	
897	FOOT ADJ STAMP PLS	AXWADJ-14905	4	

### 13.3 Washing Group Parts

#### 13.3.1. Exploded View Washing Group Parts

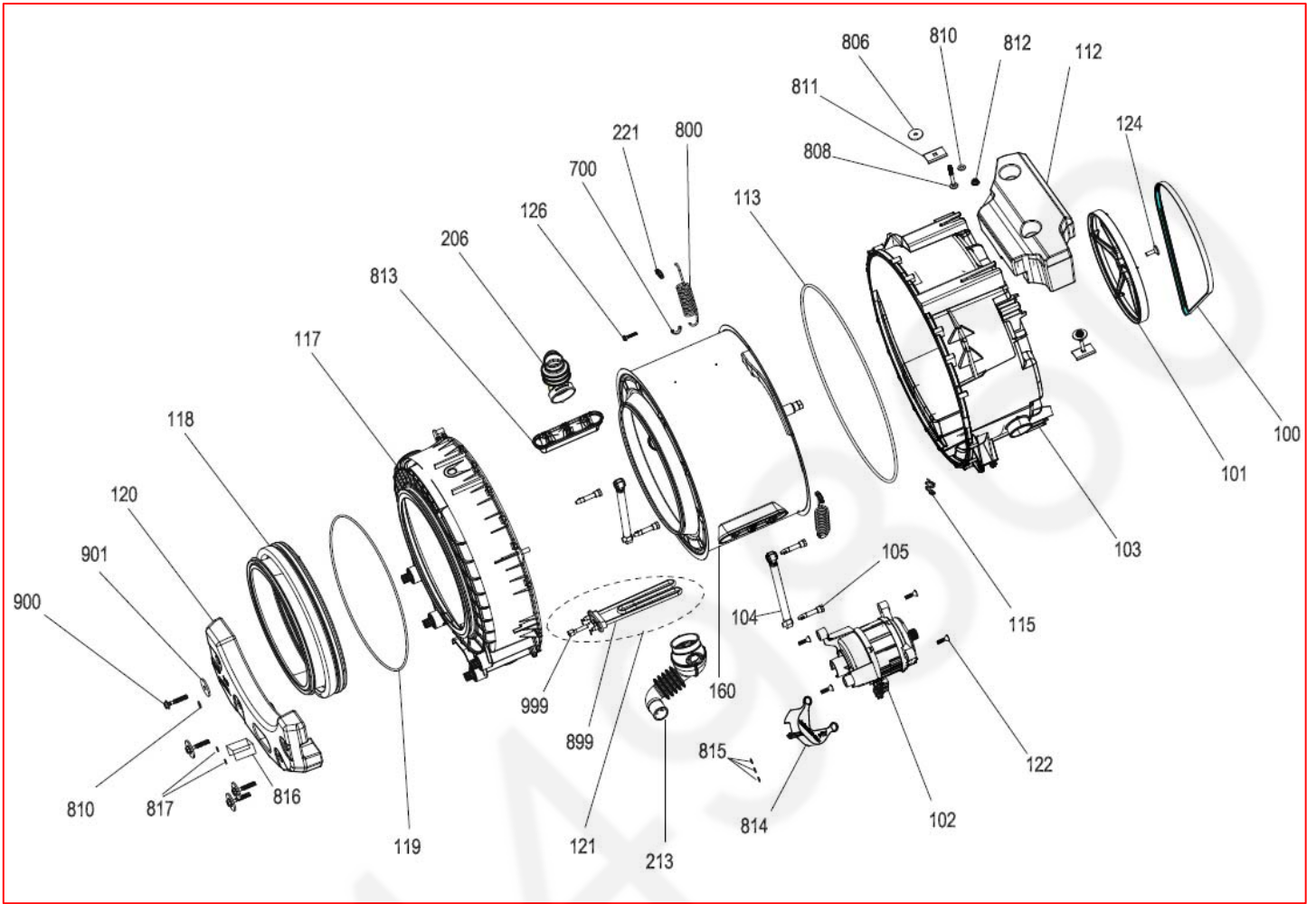



### 13.3.2. Washing Group Replacement Parts List - A

REF. NO	PART NAME	CODE	QTY	MODEL	REMARKS
103	REAR TUB GROUP	AXW12A-89470	1		
117	FRONT TUB	AXW32G-59330	1		
160	DRUM GROUP	AXW22B-33867	1		
102	MOTOR	AXW401-76070	1		⚠
113	TUB SEAL	AXW212-15077	1		
101	DRIVEN PULLEY	AXW502-00499	1		
100	BELT	AXW412-54890	1		
122	COUNTERSUNK HEAD BLT 8X28 TRX	AXWSS1-07899	4		
206	TUB ENTRANCE WITH BELLOW HOSE	AXWEBH-14409	1		
118	TUB BELLOWS SEAL	AXW212-49530	1		
126	HEXAGON HEAD BOLT 6X30 PT	AXWSS3-14521	19		
900	HEXAGON HEAD BOLT 10 X 52	AXWSB1-07415	4		
901	PLAIN WASHER 10.5X40X2.5	AXW420-08965	4		
810	CONICAL SPRING WSR 8.4X18X2	AXWSW1-15272	4		
105	SHOCK ABSORBER PIN	AXWSAP-25094	4		
119	TUB GASKET CLIP	AXW212-08555	1		
120	FRONT CONCRETE WEIGHT	AXW1231-3571	1		
121	RESISTANCE GR	AXWRG1-31166	1		⚠
999	NTC TEMP SENSOR	AXW1EV-35970	1		⚠
899	RESISTANCE WITHOUT NTC	AXWRG1-12964	1		⚠
115	RESISTANCE FIXING WIRE	AXWRFW-14491	1		
104	SHOCK ABSORBER	AXWSA1-01197	2		
213	TUB EXIT BELLOW HOSE WITH BALL	AXW1250-0200	1		
124	COUNTERSUNK HEAD BOLT M 8X29	AXWSB2-05142	1		
700	TUB HANGER SPRING PART	AXWTHS-19298	2		
800	TUB SPRING	AXW3441-5307	2		
808	MUSHROOM HED SQ NCK BLT M 8X65	AXWSB3-03063	2		
806	PLAIN WASHER 8.4X28X3	AXWSW2-07454	2		
811	UPR CRT SUPPORT SHEETIRON PART	AXWUCS-00507	2		
812	HEX.NUT W FLANGE SERRATED M8 D	AXWXNF-00615	2		
813	PLASTIC LIFTER	AXW1PL-55352	3		
112	UPPER CONCRETE WEIGHT	AXW1231-3323	1		
221	HANGER SPRING SHEETIRON PLS.	AXW1HS-16727	2		
815	SCREW TT M4X12 PAN HEAD TORX	AXWSS2-08716	3		
816	FRONT TUB-RESIST PRTECT FOIL	AXW1PF-07557	1		
817	SCW 3,5X7 P-HEAD W CLR CRS RE.	AXWSS4-15637	2		

## 13.4 Detergent Drawer Group Parts

### 13.4.1. Exploded View Detergent Drawer Group Parts

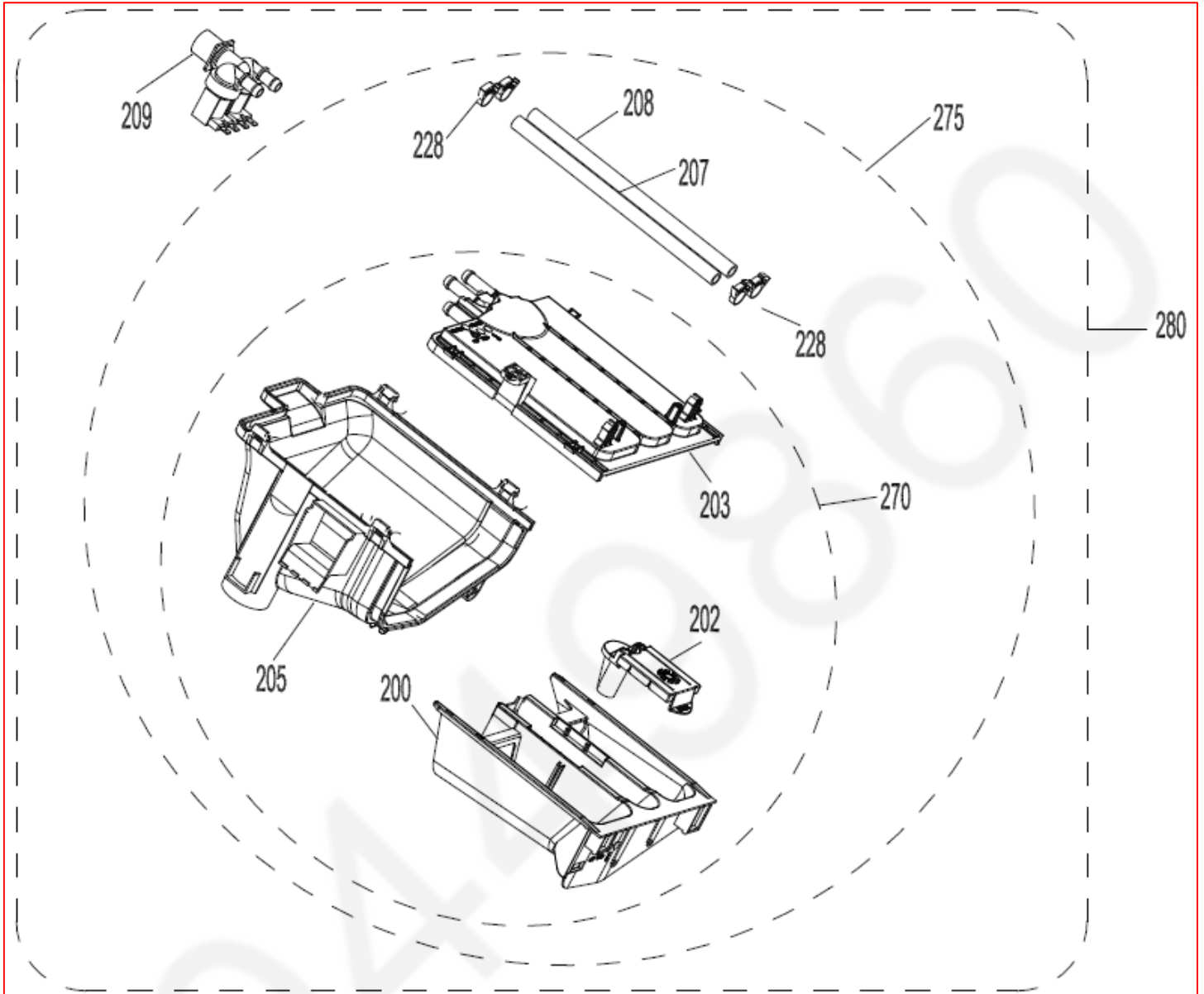

### 13.4.2. Detergent Drawer Group Replacement Parts List

REF. NO	PART NAME	CODE	QTY	MODEL	REMARKS
203	WATER DISTRIBUTION PLATE GR	AXW1WD-19141	1		
205	DETERGENT DRAWER HOUSING	AXW1DD-19136	1		
200	DETERGENT DRAWER	AXW1V-605590	1		
202	SIPHON COVER	AXW1PV-05600	1		(U)
228	PLASTIC HOSE CLAMP	AXW1PH-04189	4		
207	VALVE-DETERGENT BOX HOSE	AXW1VD-04536	1		
208	VALVE-DETERGENT BOX HOSE	AXW1VD-07796	1		
209	VALVE(TWO EXIT)	AXW1VT-13042	1		⚠
270	DETERGENT BOX GROUP	AXW21D-60571	1		
275	DETERGENT BOX GROUP/HOSE	AXW31D-60572	1		
280	DETERGENT BOX GROUP/FULL	AXW41D-56640	1		⚠

## 13.5 Pressure Switch Hose Group Parts

### 13.5.1. Exploded View Pressure Switch Hose Group Parts

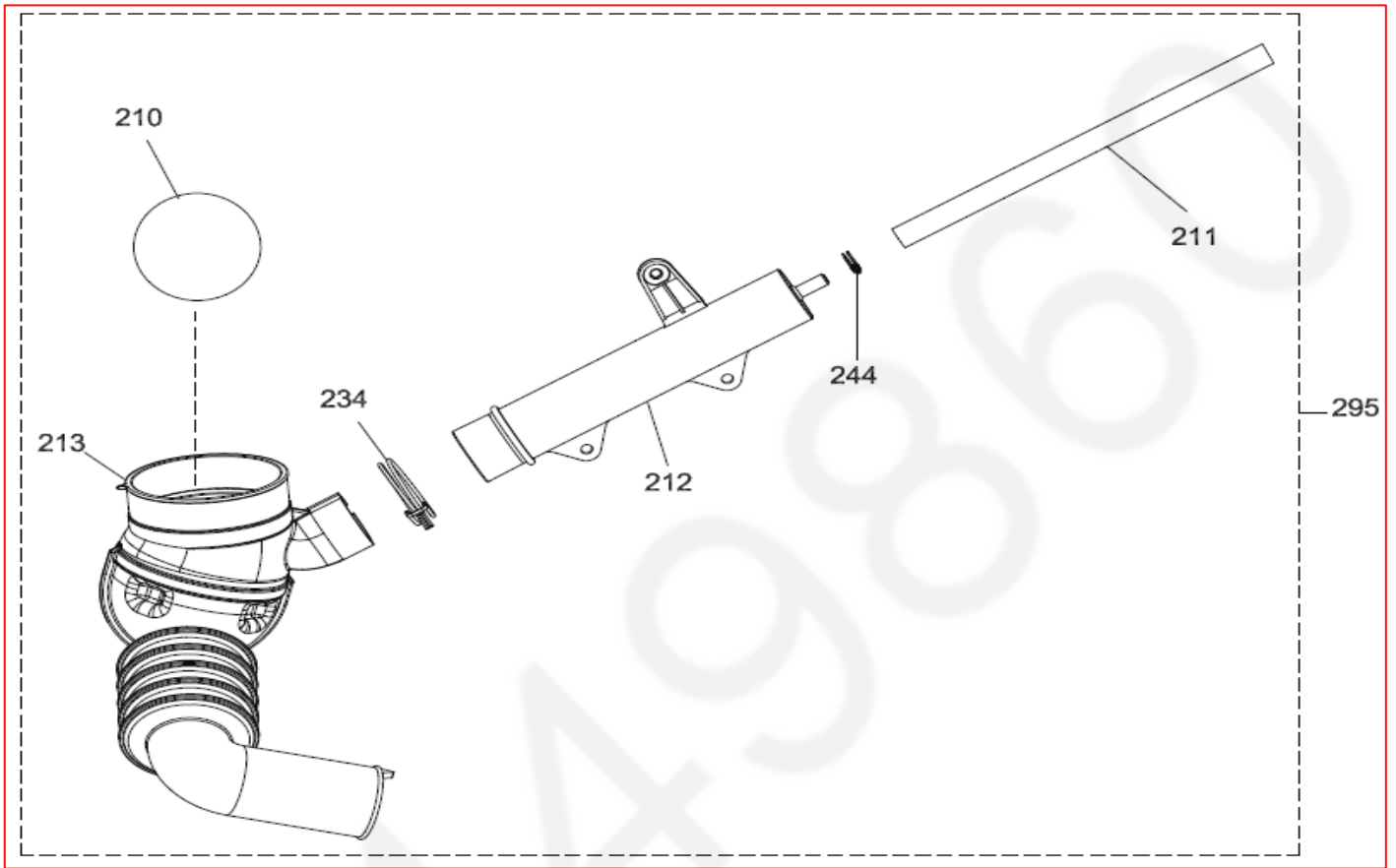

### 13.5.2. Pressure Switch Hose Group Replacement Parts List

REF. NO	PART NAME	CODE	QTY	REMARKS
210	TUB EXIT BELLOW HOSE BALL	AXW1BB-10200	1	
211	PRESSURE SWITCH HOSE	AXW1PS-19319	1	
212	PRESSURE SW WATER RESERVOIR	AXW1PS-20089	1	
213	TUB EXIT WITH BELLOW HOSE	AXW1250-4954	1	
234	HOSE HANDCUFFS O32,7	AXW1HC-07366	1	
244	HOSE HANDCUFFS	AXW1HC-08991	1	
295	PRESSURE SW H GR.PYT BALL SYST	AXW2PS-29739	1	

## 13.6 Body Group Parts

### 13.6.1. Exploded View Body Group Parts

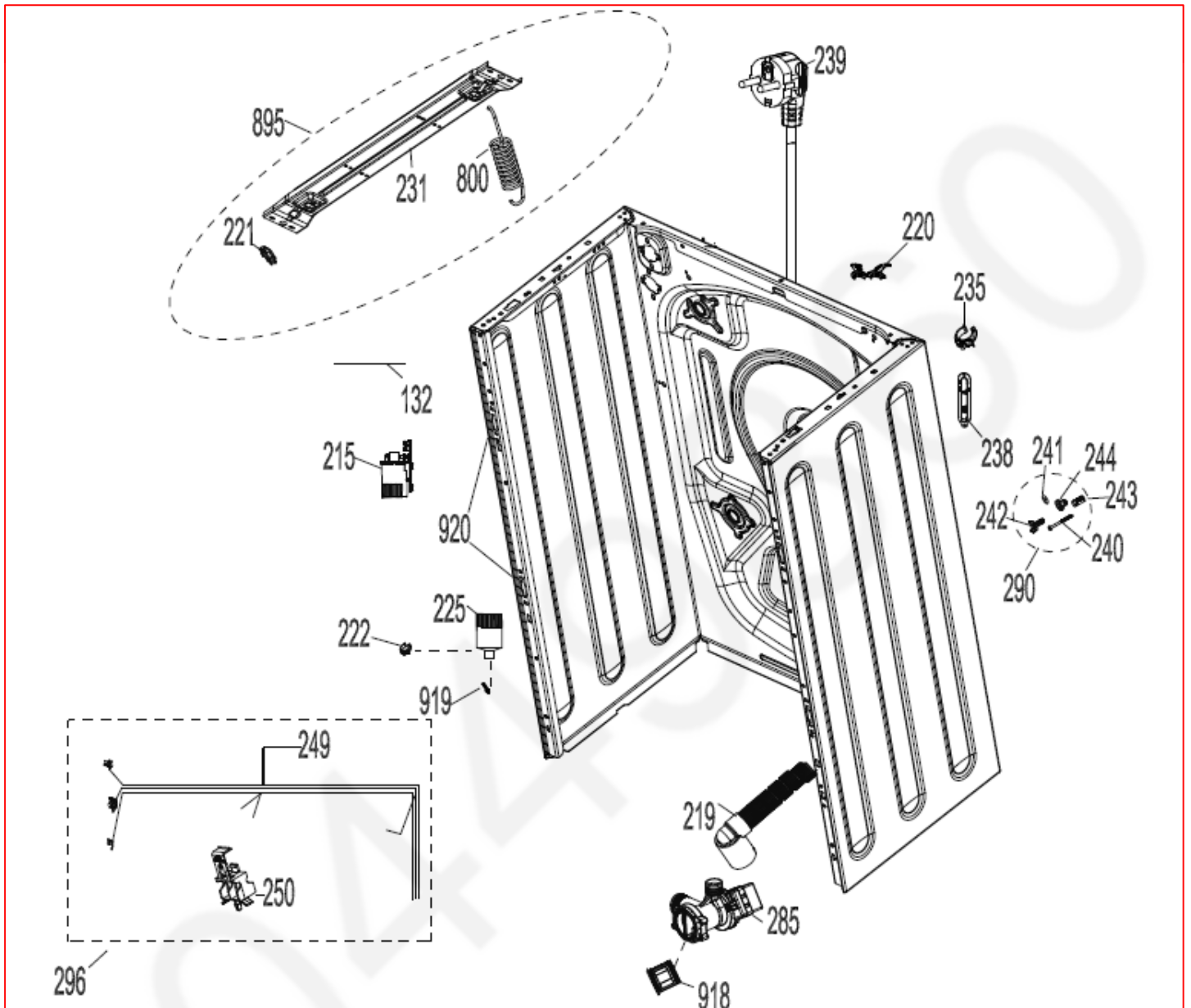

### 13.6.2. Body Group Replacement Parts List

REF. NO	PART NAME	CODE	QTY	MODEL	REMARKS
285	PUMP GR.(FLTR,TH,PROTECT)	AXW8FT-07280	1		⚠
220	DRAIN HOSE ROUTER PLASTIC	AXW1DH-19322	1		
219	DRAIN HOSE	AXW1DH-74837	1		
225	ELECTRONIC PRESSURE SENSOR	AXW1EP-06187	1		⚠
215	EMI FILTER	AXW2EF-15002	1		⚠
249	CBL HARN	AXW14B-35620	1		⚠
250	CABLE HARNESS HOLDER PLS	AXW1CH-22148	1		
800	TUB SPRING	AXW3441-5307	2		
221	HANGER SPRING SHEETIRON PLS.	AXW1HS-16727	2		
235	DRAIN HOSE HOLDING PLS	AXW1HC-14270	4		
239	POWER CORD GROUP IND	AXW4A-17560	1		⚠
222	PRESSURE SW MOUNTING CLIP	AXW1HC-22768	1		
238	SPEED CONTROL HOLE STOPPER	AXW1SC-16338	1		
296	CBL GR	AXW2CB-35610	1		⚠
242	TRANSPORT SCREW PLASTIC-A-II-P	AXW1TS-60786	4		
243	TRANSPORT SCREW PLASTIC-B-II-P	AXW1TS-60789	4		
240	TRANSPORT SCREW-2	AXWSB4-08363	4		
241	PLAIN WASHER 10.5X40X2.5	AXW420-08965	4		
231	SPRING HANGER SHEETIRON GR	AXW2SH-70737	1		
290	TRANSPORT SCREW GROUP	AXW2TS-15676	4		
132	CABLE TIE YKB150	AXWCT-075920	7		
918	DRAIN FILTER	AXWDF-653900	1		
919	HOSE CLAMP DIA 8.6	AXWHC-003440	1		
920	FRONT P DROP FIXING PL	AXWPV-204560	4		

## 13.7 Porthole Group Parts

### 13.7.1. Exploded View Porthole Group Parts

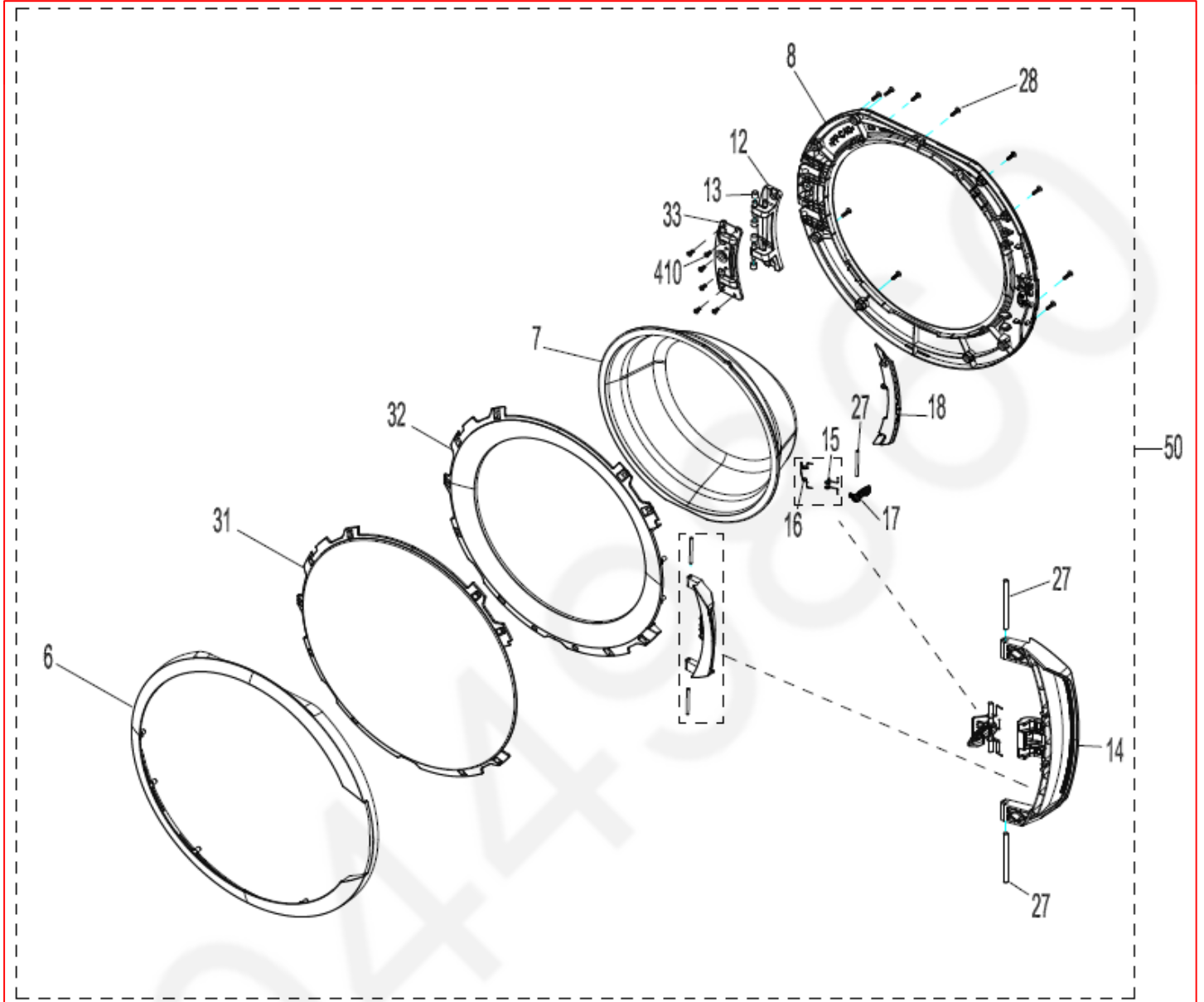

### 13.7.2. Porthole Group Replacement Parts List

REF. NO	PART NAME	CODE	QTY	REMARKS
28	SCR 3.5X16PAN.HE.W COL.CR.RE.	AXWSS7-08715	10	
8	INNER DOOR PLASTIC	AXW1DP-55347	1	
12	HINGE II-M5	AXW192-15559	1	
13	HINGE BUSHING II	AXW192-23907	4	
33	DOOR HINGE SUPPORT SHEET	AXW192-08152	1	
410	SCR 4X12PAN HE W CLR UNDER HE	AXWSB8-13513	6	
18	INNER DOOR PLS INSERT PART	AXW1DP-55348	1	
17	DOOR HOOK II.(METAL)	AXW1DH-08931	1	
15	HOOK SPRING	AXW1HS-07443	1	
16	HANDLE SPRING	AXW1HS-14985	1	
7	DOOR GLASS	AXW1GD-03771	1	
27	DOOR HANDLE TONGUE PIN	AXW1DH-07434	3	
14	DOOR HANDLE	AXW1DH-55346	1	
32	OUTER DOOR PLS. INNER FRAME	AXW1DS-55920	1	
31	FRONT DOOR COVER	AXW1DC-55940	1	
6	OUTER DOOR PLASTIC	AXW1DP-55344	1	
50	PORTHOLE GROUP	AXW2DP-55950	1	(U)

# 13.8 Accessories

## 13.8.1. Accessories View

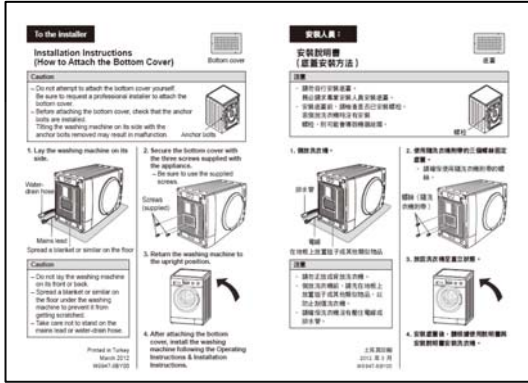

990

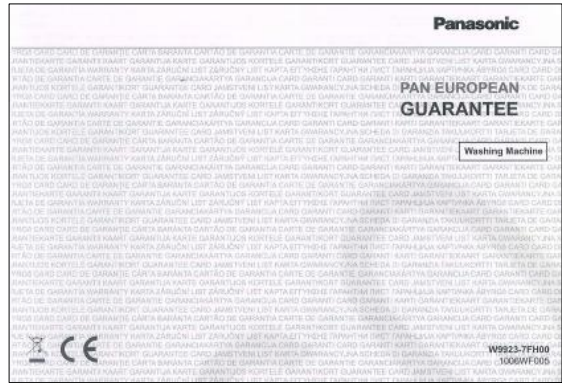

992

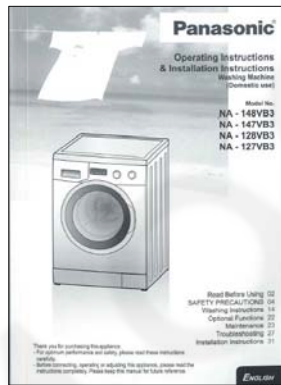

994



996



997



998

## 13.8.2. Accessories Replacement Parts List

REF. NO	PART NAME	CODE	QTY	REMARKS
990	INSTALLATION SHEET (BOTTOM COVER)	AXW4F-67869	1	
992	SERVICE LIST GUARANTEE	—	1	
994	USER'S MANUEL EN	—	1	ENGLISH
995	ENERGY LABEL	AXW90EL-8830	1	
996	LIQUID DETERGENT LEVEL PLATE	AXW90LD-9158	1	
997	DRAIN HOSE COAT RACK	AXW90HC-0601	1	
998	TRANSPORT SCREW STOPPER	AXW1TS-14437	5	



## 13.9. Packaging Group Parts

### 13.9.1. Exploded View Packaging Group Accessories

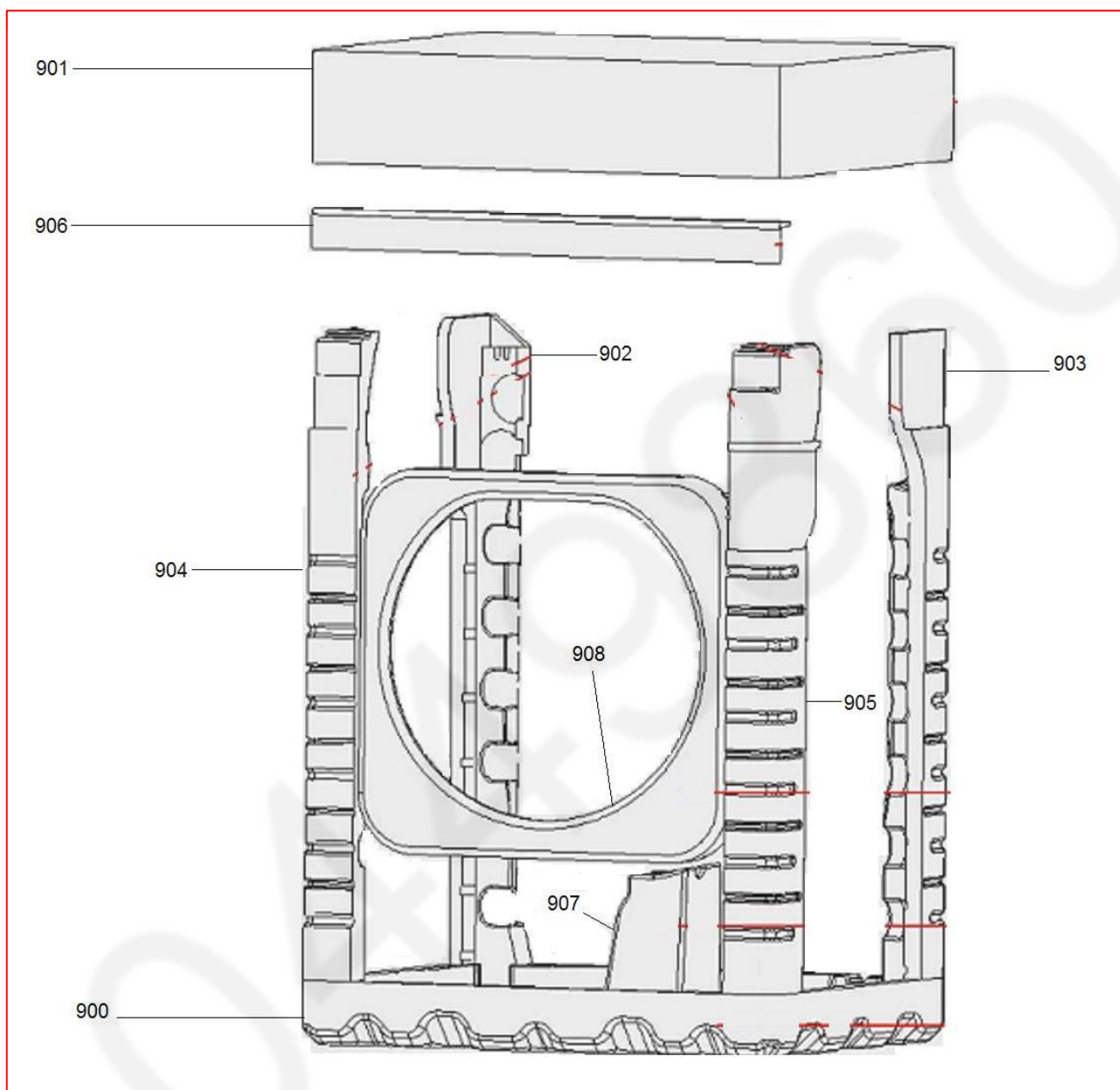



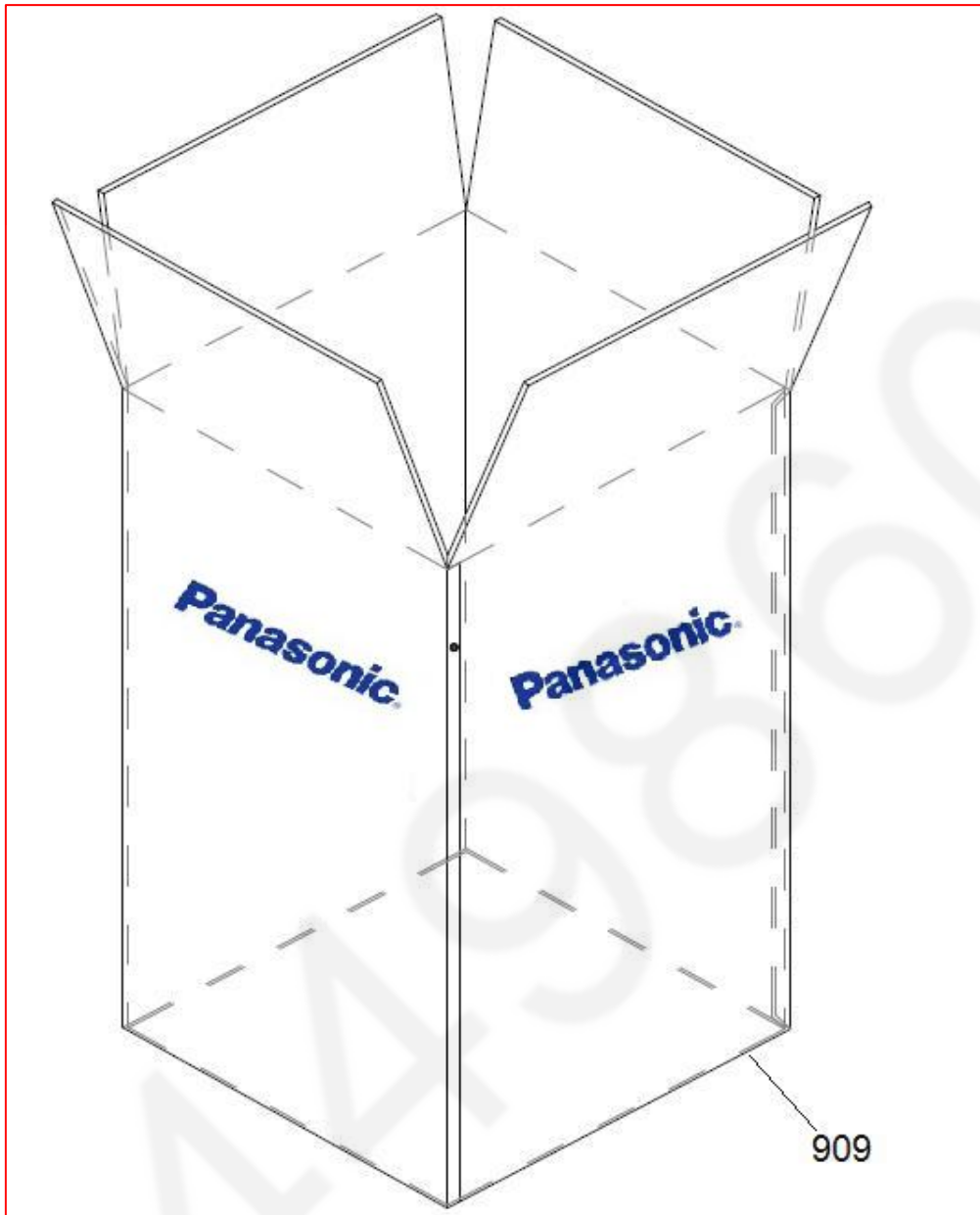

### 13.9.2. Package Group Replacement Parts List

REF. NO	PART NAME	CODE	QTY	MODEL
900	BOTTOM STYROFOAM	AXWPV-154370	1	
901	TOP CARTON	AXWPV-678640	1	
902	REAR STYROFOAM(LEFT)	AXWPV-277830	1	
903	REAR STYROFOAM(RIGHT)	AXWPV-277820	1	
904	FRONT STYRF L-SIGMA PLUS 2	AXWPV-277810	1	
905	FRONT STYRF R-SIGMA PLUS 2	AXWPV-280760	1	
906	CORNER CARDBOARD	AXWPV-002040	1	
907	TUB SUPPORT STYROFOAM	AXWPV-053000	1	
908	PORTHOLE PRO. STYROFOAM	AXWPV-244940	1	
909	PACKAGE CARTON 7K	-	1	