

Service Manual

Vacuum Cleaner

Model No. **MC-YL699-S146**
MC-YL699-S346
MC-YL699-S149
MC-YL699-S747
MC-YL699-S147

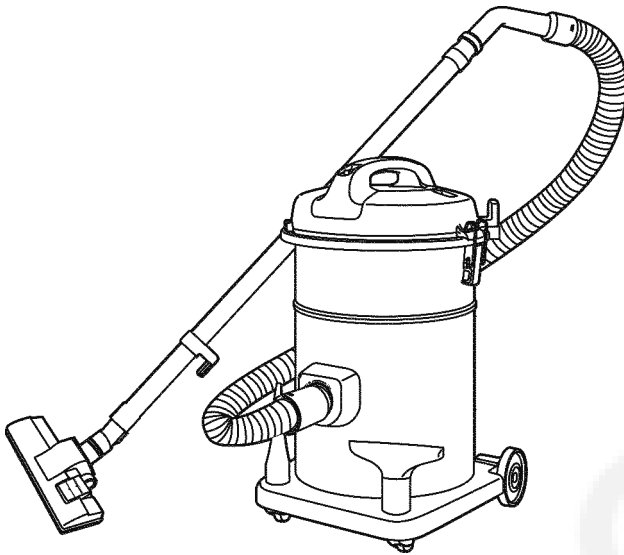

Product Color : Black & Silver
 Destination : 1.General -----YL699-S146
 2.Egypt -----YL699-S346
 3.Iran -----YL699-S149
 4.Saudi Arabia -----YL699-S747
 Kuwait
 5.UAE -----YL699-S147

⚠ WARNING

This service information is designed for experienced repair technicians only and is not designed for use by the general public. It does not contain warnings or cautions to advise non-technical individuals of potential dangers in attempting to service a product. Products powered by electricity should be serviced or repaired only by experienced professional technicians. Any attempt to service or repair the product or products dealt with in this service information by anyone else could result in serious injury or death.

IMPORTANT SAFETY NOTICE

There are special components used in this equipment which are important for safety. These parts are marked by **⚠** in the Schematic Diagrams, Circuit Board Diagrams, Exploded Views and Replacement Parts List. It is essential that these critical parts should be replaced with manufacturer's specified parts to prevent shock, fire or other hazards. Do not modify the original design without permission of manufacturer.

TABLE OF CONTENTS

	PAGE		PAGE
1 Specifications	2	7 Exploded View and Replacement Parts List	12
2 Location of Controls and Components	3	7.1. EXPLODED VIEW (ATTACHMENTS)	12
3 Troubleshooting Guide	5	7.2. PARTS LIST (ATTACHMENTS)	12
4 Disassembly and Assembly Instructions	6	7.3. EXPLODED VIEW (BODY UNIT)	13
4.1. Main body and the dust box separation	6	7.4. PARTS LIST (BODY UNIT)	14
4.2. Motor removal	6	7.5. PACKING INSTRUCTIONS	15
4.3. Air outlet cover unit removal	8	7.6. PACKING LIST	16
4.4. Main switch (with fuse) removal	8		
4.5. Fuse replacement	9		
4.6. Power cord replacement	9		
4.7. Indicator pipe unit removal	9		
4.8. Cloth bag unit removal	10		
5 Wiring Connection Diagram	11		
6 Schematic Diagram	11		

Panasonic®

© Panasonic Corporation 2009 Unauthorized copying and distribution is a violation of law.

1 Specifications

Model No.	MC-YL699
Motor power	2100W
Dust capacity	20.0L
Cord Length	8.0m
Weight (With Attachments)	7.2kg
Extension Wand	METAL × 2
Blower Operation	I
Floor Nozzle	2-Step
Dimensions (WxLxH)	584mm x 340mm x 366mm
Attachments	Crevice Tool / Upholstery Nozzle

Specifications are subject to change without notice for further improvement.

2 Location of Controls and Components

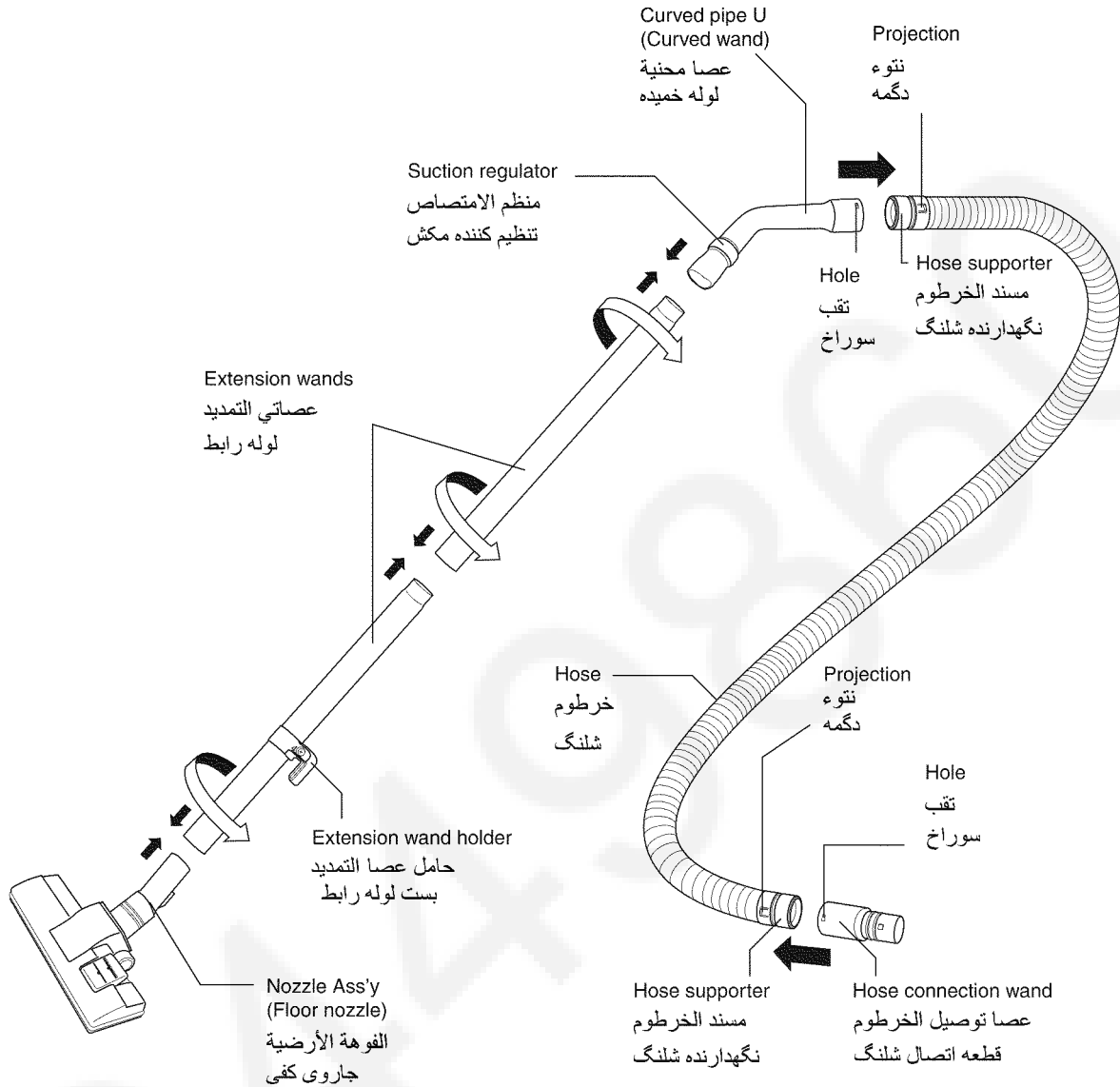

NOTE

- At the beginning when you purchase this product, accessories like curved wand, hose, crevice tool and upholstery nozzle are located inside the dust box.
- Push together until the projection clicks into place in the curved wand / hose connection wand hole.

توجه

- عند بداية شراء هذا المنتج، فإن ملحقات مثل العصا المنحنية والخرطوم وأداة الشق وفتحة الفرش تكون داخل صندوق الغبار.
- ادفع معا حتى ينحکم النتوء بطقه في مكانة داخل فتحة العصا المنحنية / عصا توصيل الخرطوم.

ملاحظة

- در ابتدا که این محصول را خریداری می‌کنید، تجهیزات جانبی آن مانند لوله خرطومی، شیلنگ، گوشه گیر و سر شیلنگی در محفظه گرد و غبار قرار دارند.
- لرامدگی لوله خمیده را خوب در حفره رابط ورودی وصل لوله جاروبرقی وارد نمایید تا خوب جا بیفتد.

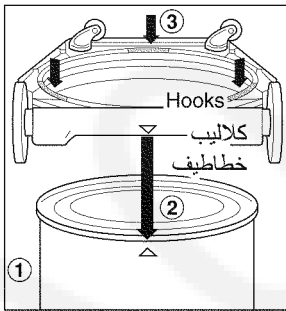
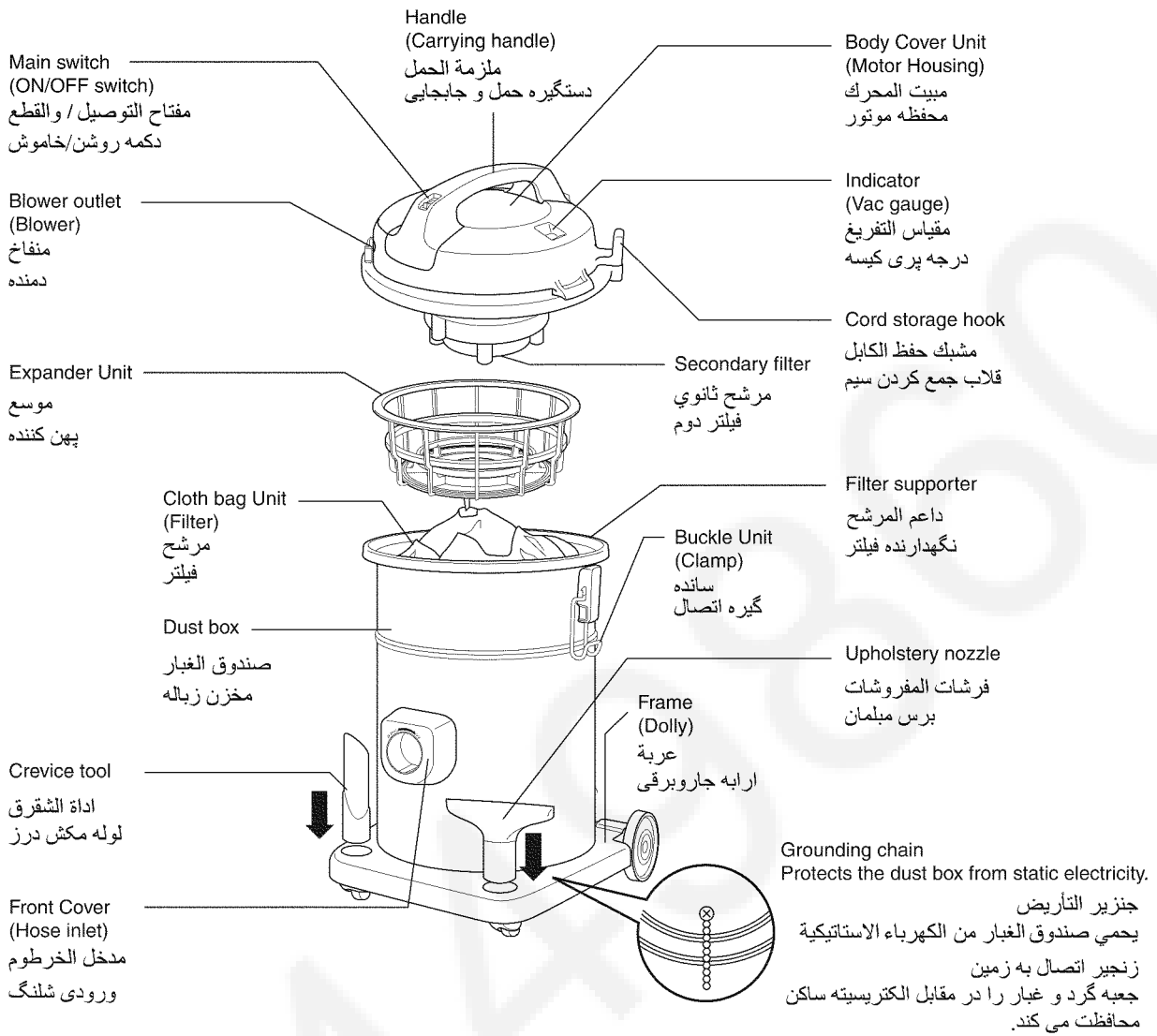

- Align the triangle markings and push in the dust box until it clicks into place with the dolly. (Once it is fixed into place, it cannot be removed.)
- خذ العلامات المثلثية وادفع صندوق الغبار حتى ينحکم بطقة في مكانه في العربة. (عندما يثبت في مكانه، لن يمكن رفعة.)
- علامت سه گوش را خوب بر هم منطبق و تنظیم نموده، مخزن زباله را با فشار جا بزنیید به نحوی که (مخزن زباله به خوبی بروی چرخ سوار و نصب شود.)

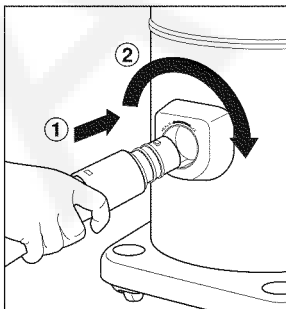

- Insert the hose connection wand into the hose inlet.
- ادخل عصا توصيل الخرطوم بمدخل الخرطوم.
- رابط لوله ای اتصال شلنگ را در قسمت ورودی شلنگ قرار دهید.

3 Troubleshooting Guide

CONDITION	CHECKPOINT	METHOD OF INSPECTION	CAUSE / REMEDY
Motor fails to rotate when it is switched on	Meltdown of fuse unit	Check fuse continuity. (Visual and conduction check)	Replace the main switch (with fuse). *Check the motor at same time. There may be the possibility of a motor problem
	Continuity of power cord unit	Check power supply cord continuity. Check the continuity between 1. Lead wire connection of main unit switch 2. Lead wire connection terminal of the motor and the blades of the plug using a tester.	Replace the power cord unit
	Continuity of the switch	Check with tester between both terminals on the switch, while turning switch ON/OFF.	If there is no continuity, replace the main switch (with fuse).
	Check of the motor connection faston terminals	Check if it is securely connected by pulling on the lead wire.	Securely connect.
	Continuity of the motor	Check the continuity between both terminals (1. Orange connection of lead wire 2. Brown connection of lead wire) (lead wire connection terminal) of the motor.	If there is not continuity, replace motor set. (Disconnection of the coil inside the motor)
	Wearing of the carbon brush	Visually check if one side of the carbon brush is worn out abnormally.	Replace motor set.
Suction is weak	Clogging in extension pipe / nozzle assy / hose assy	Check for clogging in each part	Remove dust or replace parts
	Clogging in the cloth bag / filter of the dust compartment	Check for clogging in each part	Clean
Abnormal sound	Indicator pipe unit (Air protector)	Is it full of dust? Clogging	Clean Remove dust from each parts
	Motor	Problem with the motor or carbon brush	Replace the motor set.

4 Disassembly and Assembly Instructions

Caution:

1. When disassembling, check the component fitting state and wirings. After repairing, always restore them to the original state.
2. Carefully handle the removed components, packing, etc. If they are damaged, then replace them with new ones.
3. After repairing, check that the components, etc., in the vicinity of the repaired sections are not damaged, the removed components are in place, and the wirings are restored to the original state. Carry out the test run. Also check that the following requirements are met.
 - Insulation resistance
Must be $5\ \Omega$ or more when a DC voltage of 500 V is applied across the power plug and the motor core for one second.
 - Dielectric strength
Must withstand an AC voltage of 1,250 V applied across the power plug and the motor core for one minute.
4. Do not alter the model, parts, or materials during repair.
5. If a wiring unit is supplied as a repair part, replace the whole unit with the new one instead of repairing or reconnecting the broken portions only.
6. Insert/remove the fast-on terminals by pushing/pulling them straight out without jiggling them or applying unnecessary force.

4.1. Main body and the dust box separation

1. Remove the buckle, and remove the main body from the dust compartment.

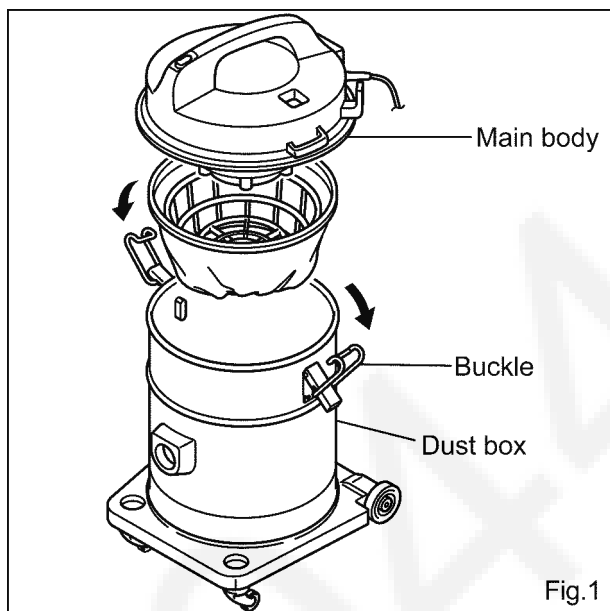

4.2. Motor removal

1. Flip the main body, and remove the 4 screws holding the upper body unit with the body cover unit, and remove the upper body.

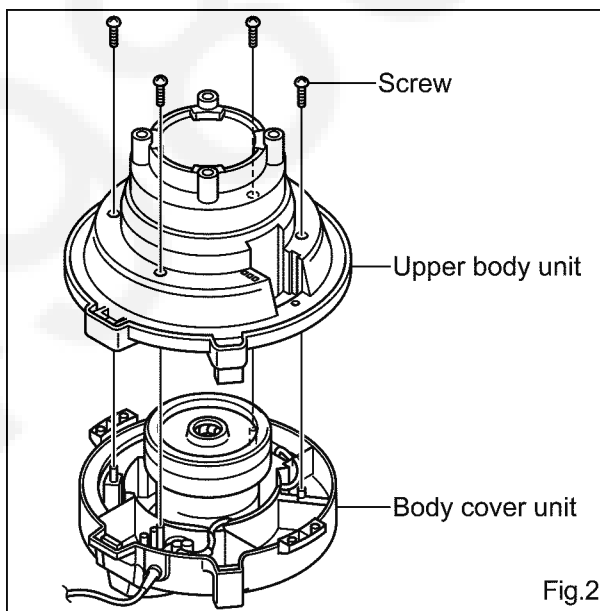

2. Separate the motor from the body cover.

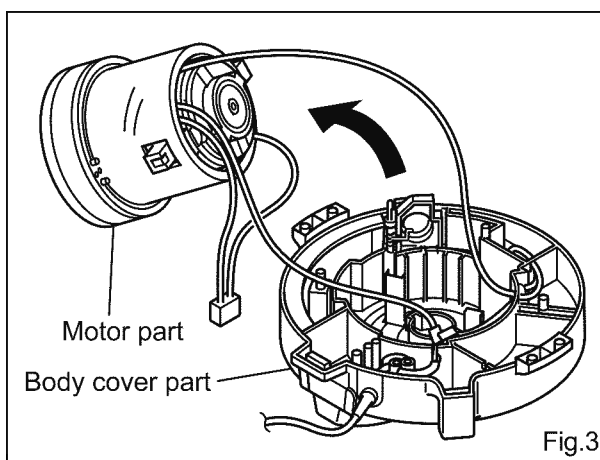

<Assembly precaution>

When mounting, align form of the motor support rubber (rear) unit with form of the body cover connection

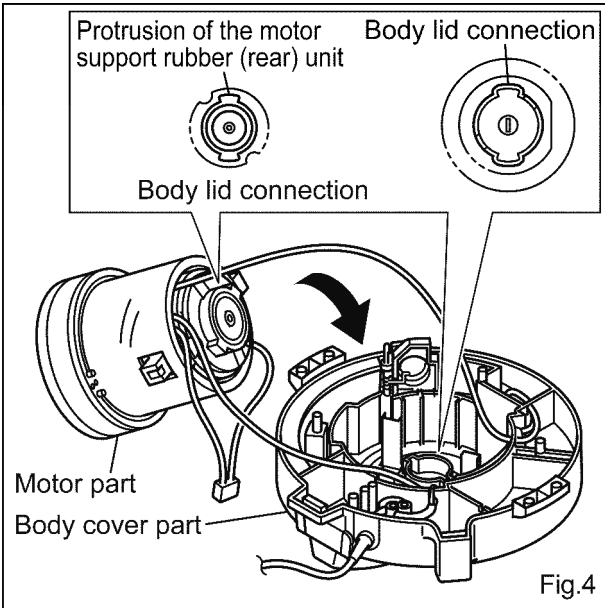

4. Remove the noise suppressor unit, the motor support rubber (front), and the motor support rubber (rear) unit.

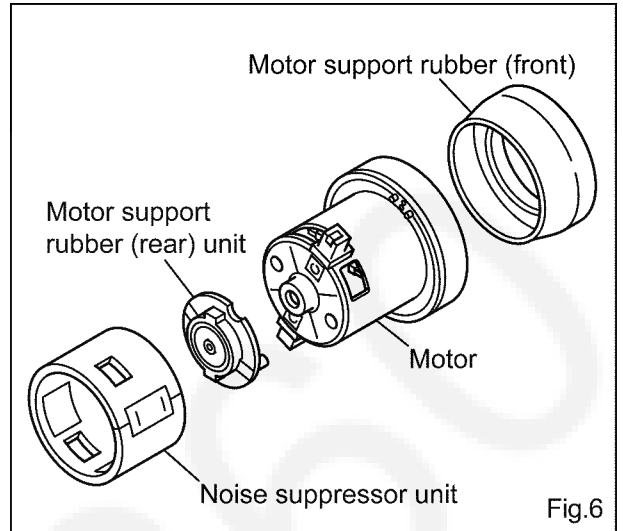

3. Remove the lead wires by shifting the noise suppressor unit.

* Take care not to damage the noise suppressor when shifting the noise suppressor unit.

* There is a tape (glass tape) wrapped on the faston terminals, and when removing the faston terminals, press on to the protrusion on the faston terminal (arrow) as shown in fig. 5.

It can be removed by pressing on the tape from above.

* When mounting the motor, make sure to wrap the faston terminals of the connected lead wires with the protection tape B (glass tape).

⚠ WARNING	
!	Pull the faston terminals straight out without twisting.

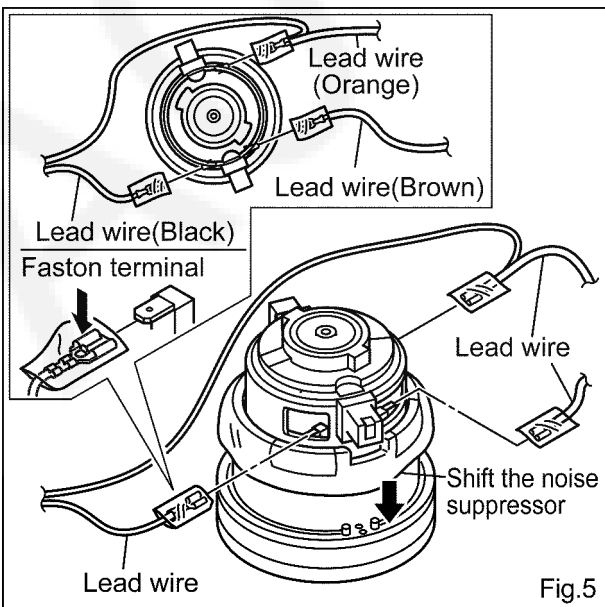

4.3. Air outlet cover unit removal

1. Peel off the exhaust packing unit and remove the air outlet cover unit.

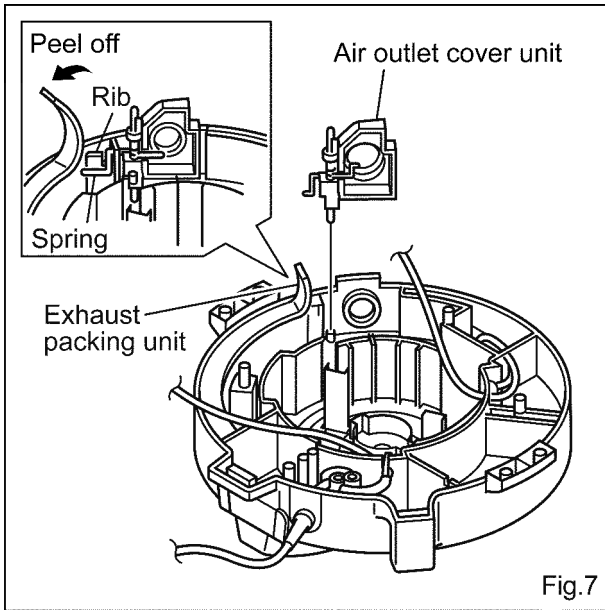

Fig.7

* Locations of parts mounted to air outlet cover unit

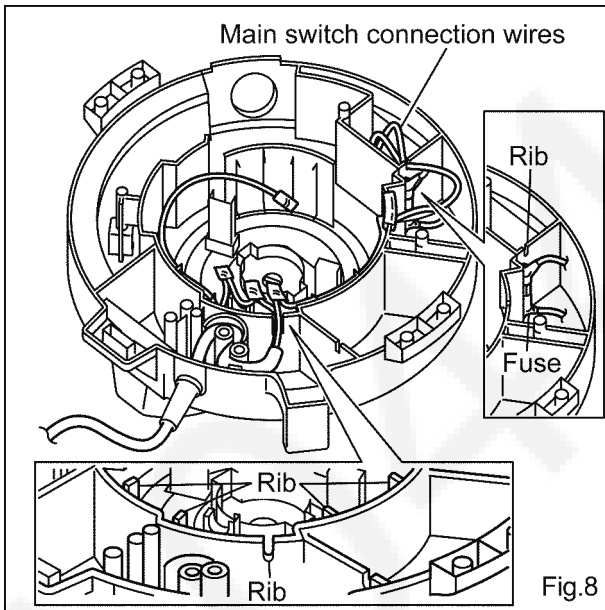

Fig.8

4.4. Main switch (with fuse) removal

1. Remove the 2 screws mounting the handle.
2. Flip the body cover and remove the handle.

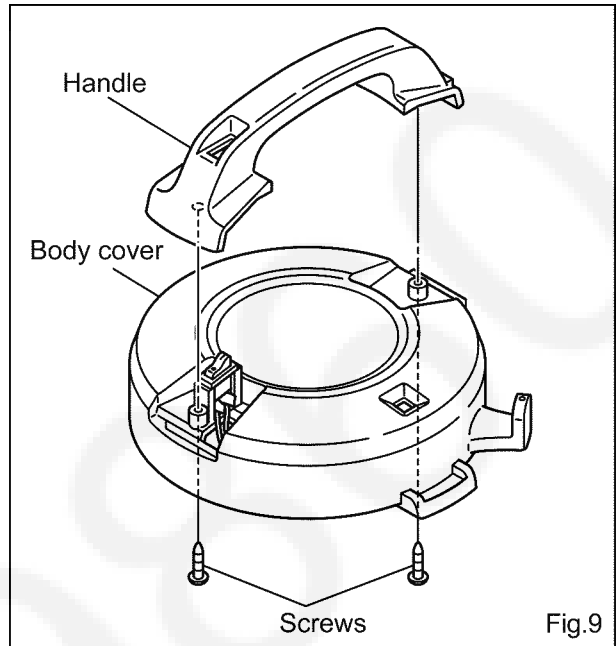

Fig.9

3. Remove the main switch and replace with the new main switch.

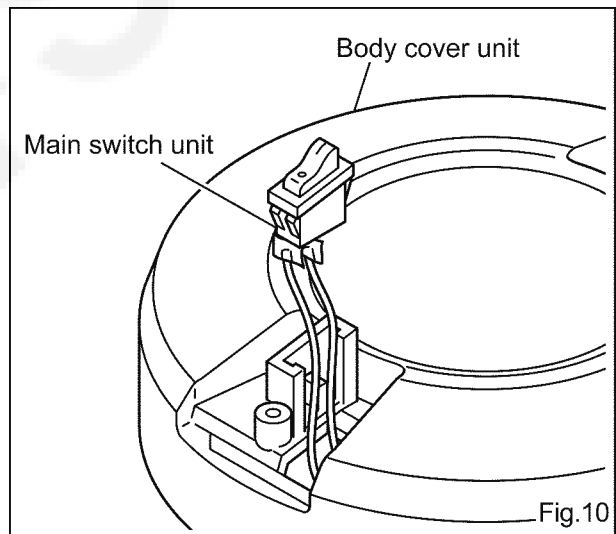
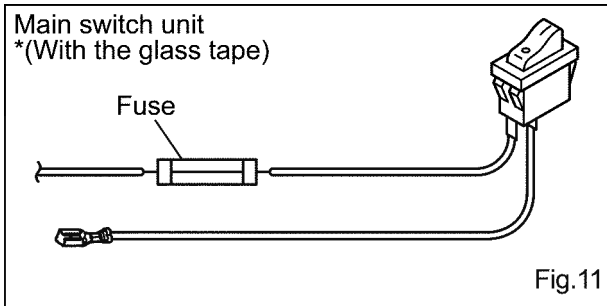

Fig.10

* Main switch has a fuse built-in.
Also, there are tapes (glass tapes) wrapped on each part.

4.5. Fuse replacement

* Fuse is supplied by the main switch (with fuse)



4.6. Power cord replacement

1. Cut the lead wires at the root of the crimp contact and remove the power cord.

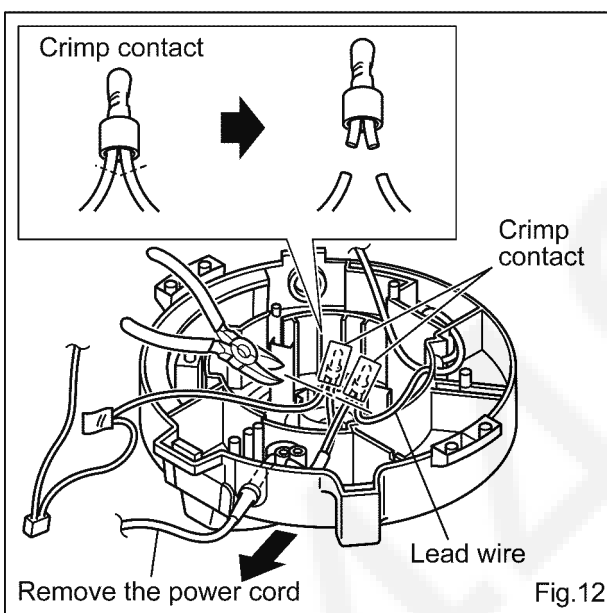

* Make sure to wrap the crimp contact with the protection tape B (glass tape) after replacement.

2. Place the new power cord between the ribs of the body cover unit, and connect the wires with crimp contact.

* Use the dedicated tool to crimp the crimp contact
* Wrap the crimp contact with the protection tape B (glass tape).

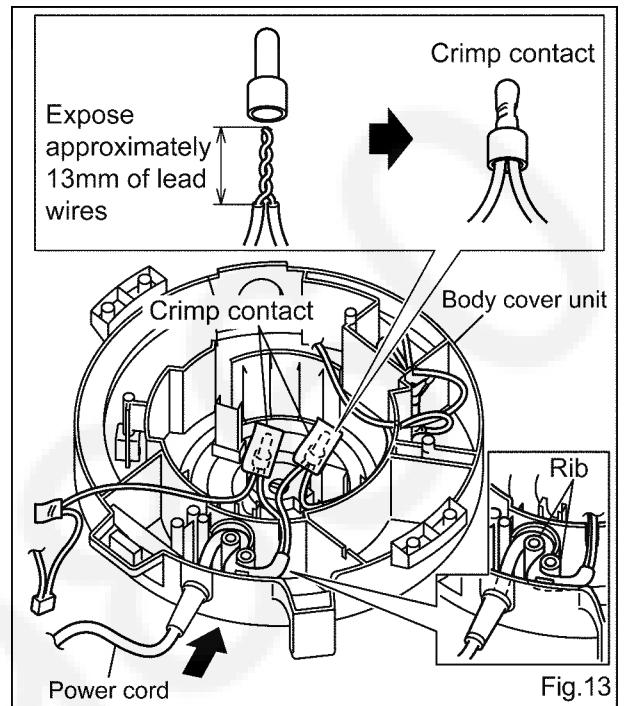

4.7. Indicator pipe unit removal

1. Remove the 1 screw mounting the indicator pipe unit with the body upper unit, and remove the indicator pipe unit.

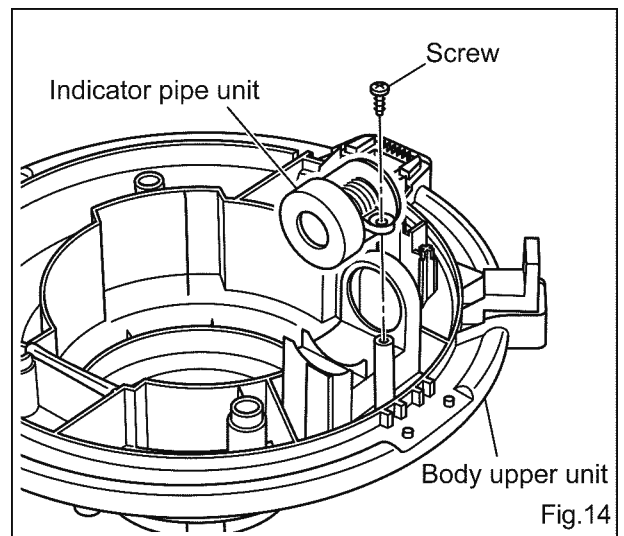

4.8. Cloth bag unit removal

1. Remove the cloth bag unit from the expander.

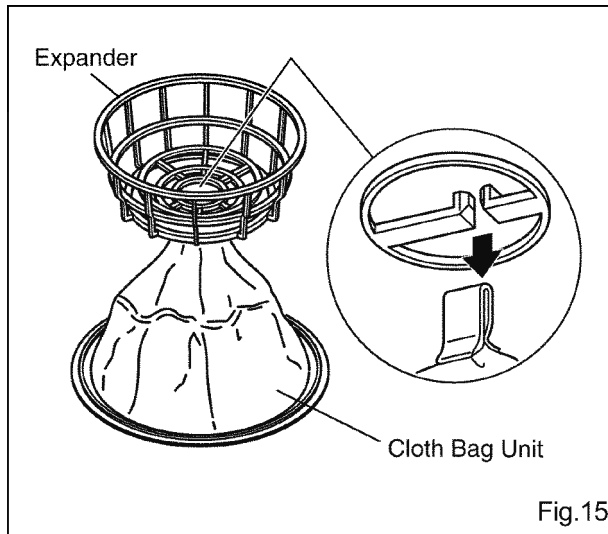

5 Wiring Connection Diagram

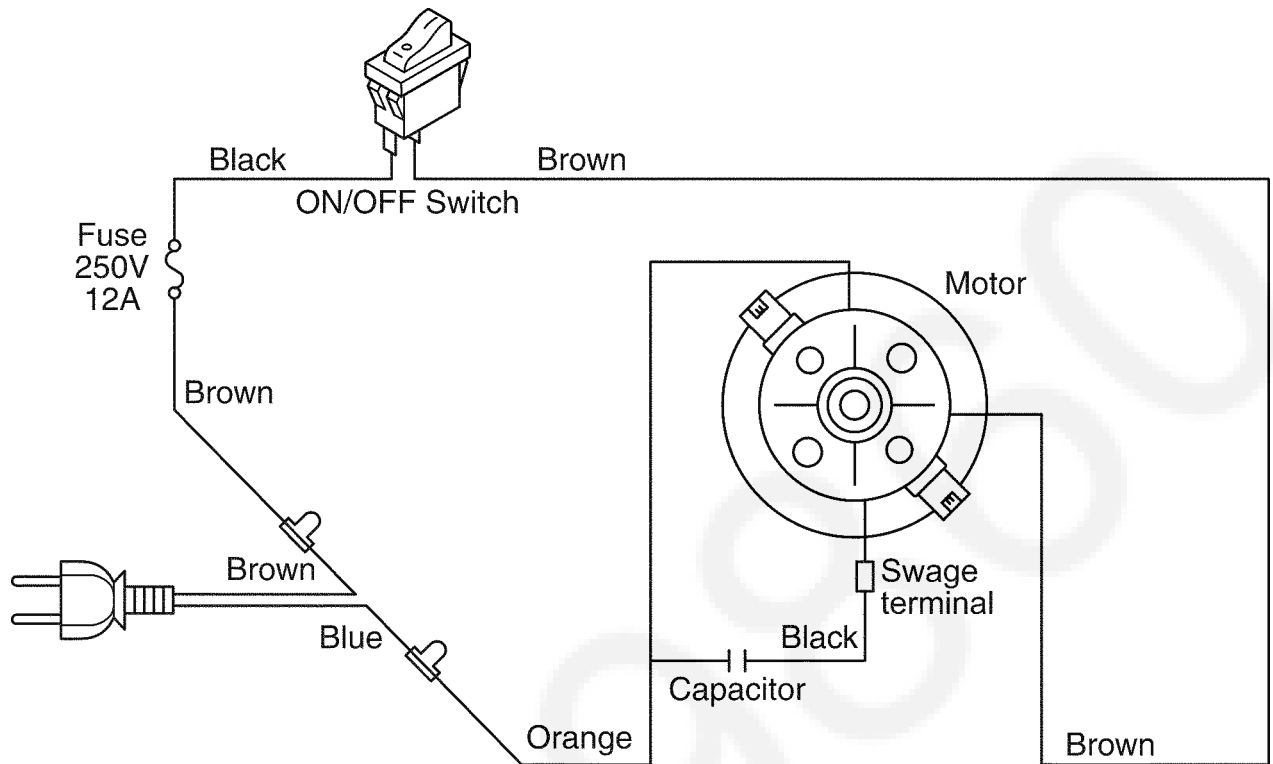

6 Schematic Diagram

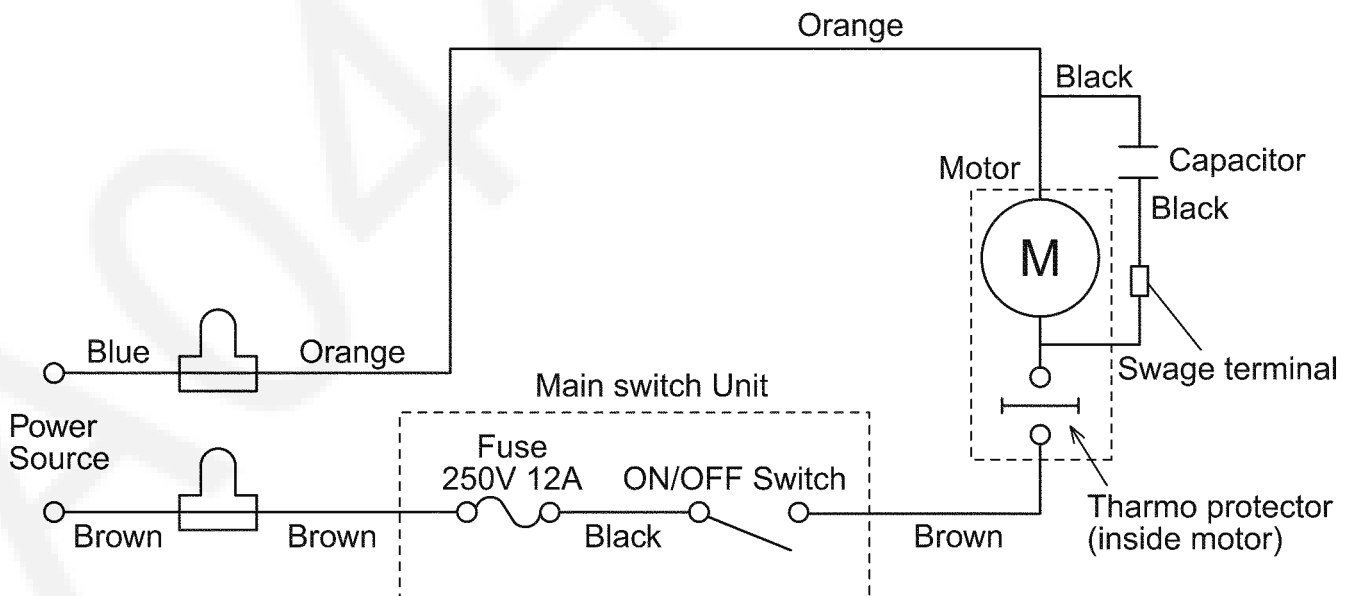

7 Exploded View and Replacement Parts List

7.1. EXPLODED VIEW (ATTACHMENTS)

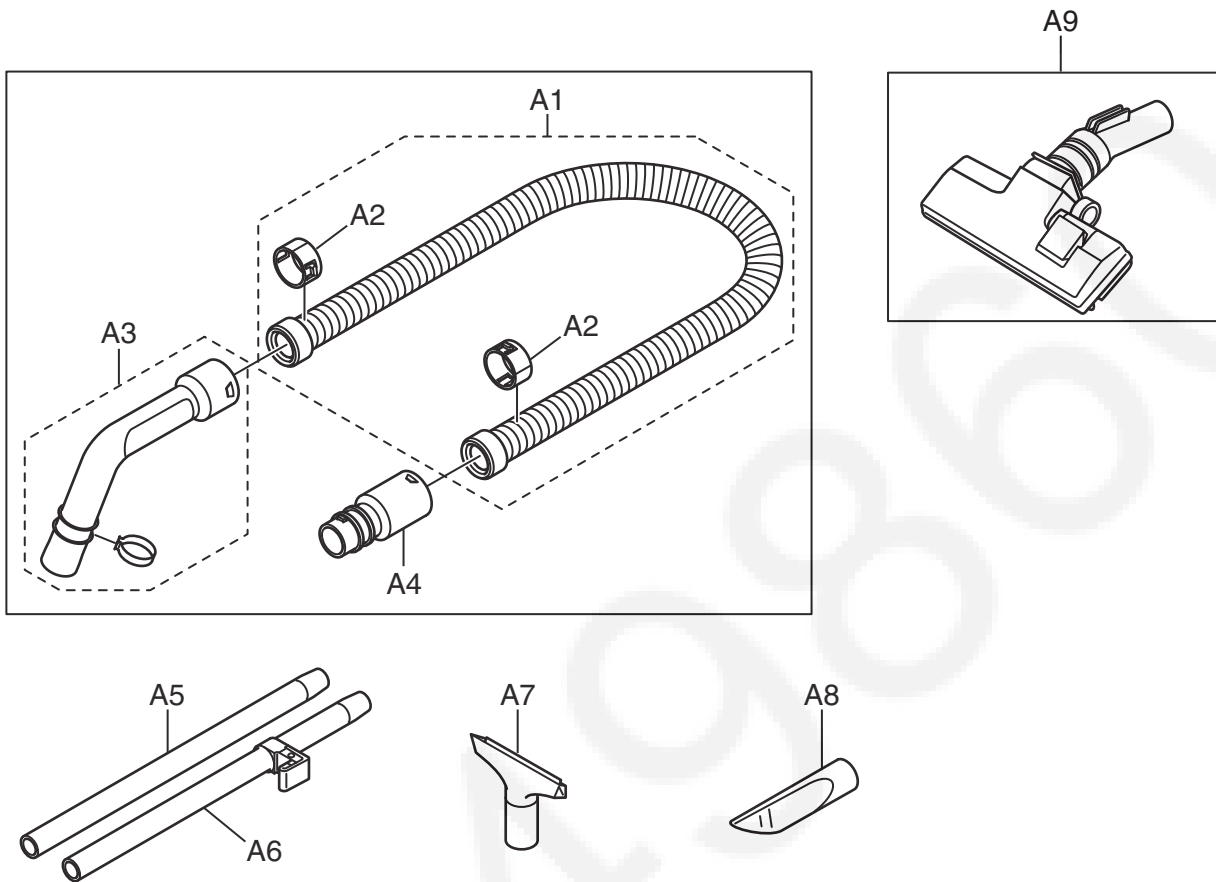

7.2. PARTS LIST (ATTACHMENTS)

Safety	Ref.No	Service Parts No.	Part Name & Description	Q'TY	Remarks
	A1	AMC84P-DD0V	HOSE U	1	
	A1	AMC84P7X000J	HOSE U	1	UAE only
	A2	AMC24P-OR0V	HOSE SUPPORTER	2	
	A3	AMC98P4Y000J	CURVED PIPE UNIT	1	
	A4	AMV09P99000J	JOINT PIPE UNIT	1	
	A5	AMC99PDE000J	EXTENSION WAND UNIT	1	
	A6	AMV99P81000J	EXTENSION WAND UNIT	1	With Holder
	A7	AMV86R81000J	UPHOLSTERY NOZZLE	1	
	A8	AMC60R-DB03	CREVICE TOOL	1	
	A9	AMC99R-RS0U	NOZZLE ASSY	1	

7.3. EXPLODED VIEW (BODY UNIT)

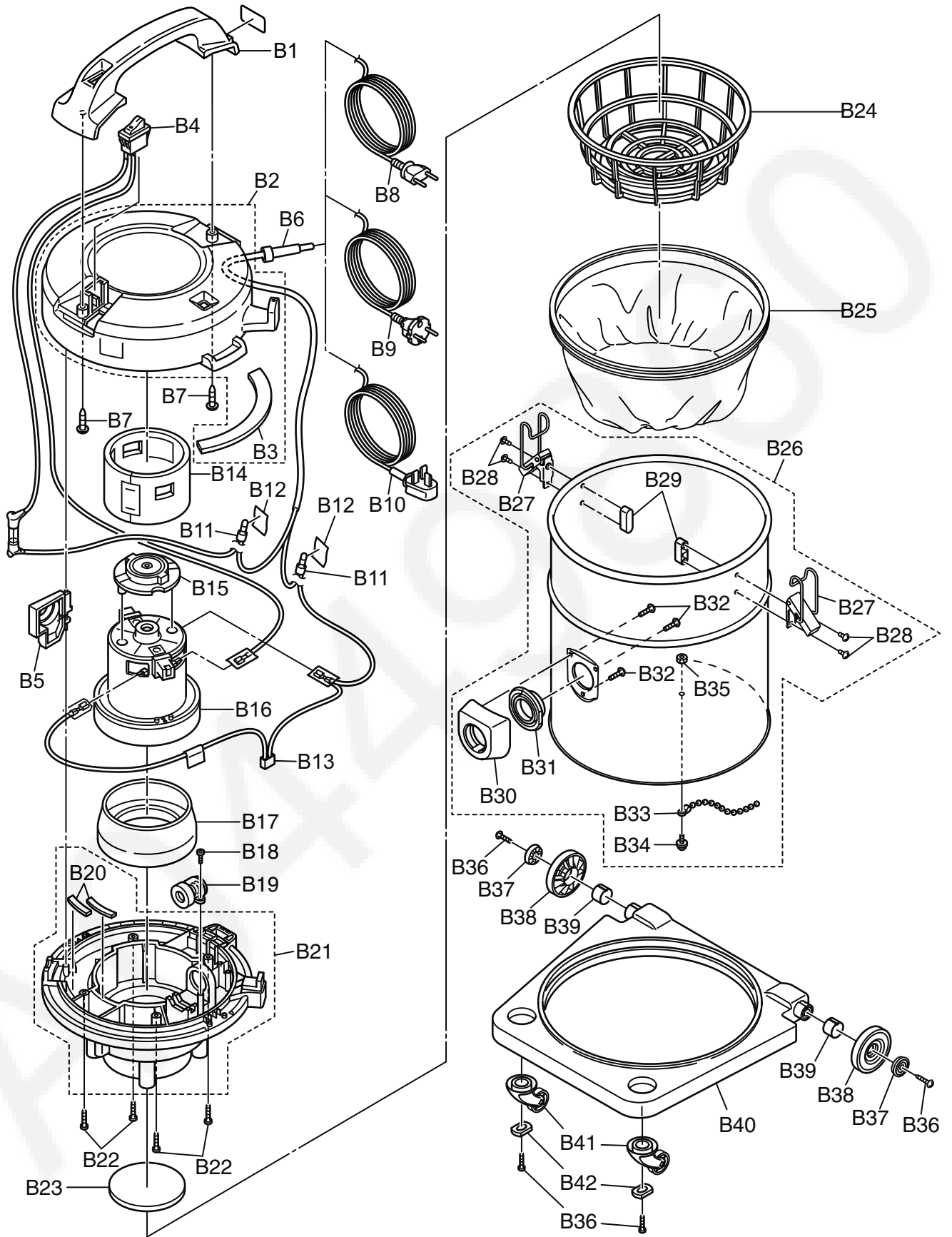

7.4. PARTS LIST (BODY UNIT)

Safety	Ref.No	Service Parts No.	Part Name & Description	Q'TY	Remarks
	B1	AMV01B810K0J	HANDLE	1	(Carrying handle)
	B2	AMV92A990K0J	BODY COVER UNIT	1	(Moter Housing)
	B3	AMV85L81000J	EXHAUST PACKING UNIT	1	
△	B4	AMV98E8100CJ	MAIN SWITCH	1	With Fuse 12A
	B5	AMC96L-DD0V	BLOWER OUTLET UNIT	1	With Cover Spring
	B6	AMC51E-BY0	CORD BUSHING	1	
	B7	XTT4+20BFJ	TRUSS SCREW	2	
△	B8	AMC96E-VH0	POWER CORD W/PLUG (C2P)	1	Egypt. General
△	B9	AMC91EVH00EJ	POWER CORD	1	Iran only
△	B10	AMC93EVG008J	POWER CORD W/PLUG (C3P)	1	Saudi Arabia. Kuwait. UAE
	B11	CE-230	CRIMP CONTACT	2	WIRE CONNECTOR
△	B12	AMS7RAS5000J	PROTECTION TAPE B	2	(Service exclusive use)
△	B13	AMV94F81000J	CAPACITOR UNIT	1	
	B14	AMV99G81000J	NOISE SUPPRESSOR UNIT	1	
	B15	AMV0AF99000J	MOTOR SUPPORT RUBBER UNIT (REAR)	1	
△	B16	AMV0FF9900CJ	MOTOR SET	1	AC220V-240V
	B17	AMV02F99000J	MOTOR SUPPORT RUBBER (FRONT)	1	
	B18	XTN4+12BFJ	SCREW	1	
	B19	AMV99M81000J	INDICATOR PIPE UNIT	1	(Vac gauge)
	B20	AMV81A81000J	TIGHT PACKING	2	
	B21	AMV98A990K0J	UPPER BODY UNIT	1	
	B22	XTN4+25BFJ	SCREW	4	
	B23	AMC30K-QN0	FILTER	1	(Secondary filter)
	B24	AMC18K-DD0	EXPANDER	1	
	B25	AMV99K810H0J	CLOTH BAG UNIT	1	(Filter)
	B26	AMV0QA99000J	LOWER BODY ASSY	1	
	B27	AMV99D810K0J	BUCKLE UNIT	2	(Clamp)
	B28	XTN4+12BFJ	SCREW	4	
	B29	AMV32D81000J	BUCKLE PLATE	2	
	B30	AMC01HDD0V0J	FRONT COVER	1	(Hose inlet)
	B31	AMC50K-J300C	VALVE GROMMET	1	
	B32	XTT35+16BFJ	SCREW	3	
	B33	AMC56HQN000J	GROUNDING CHAIN	1	
	B34	XYN3+F8FJ	SCREW	1	
	B35	XNG3EFJ	NUT	1	
	B36	XTN4+16BFJ	SCREW	4	
	B37	AMC05C-L90H	WHEEL CAP	2	
	B38	AMC01C-9403	WHEEL	2	
	B39	AMC02C-9700C	WHEEL SUPPORTER	2	
	B40	AMC43A-QN0V	FRAME	1	(Dolly)
	B41	AMC95C-0E0H	CASTER UNIT	2	
	B42	AMC26C-B00	CASTER WASHER	2	

7.5. PACKING INSTRUCTIONS

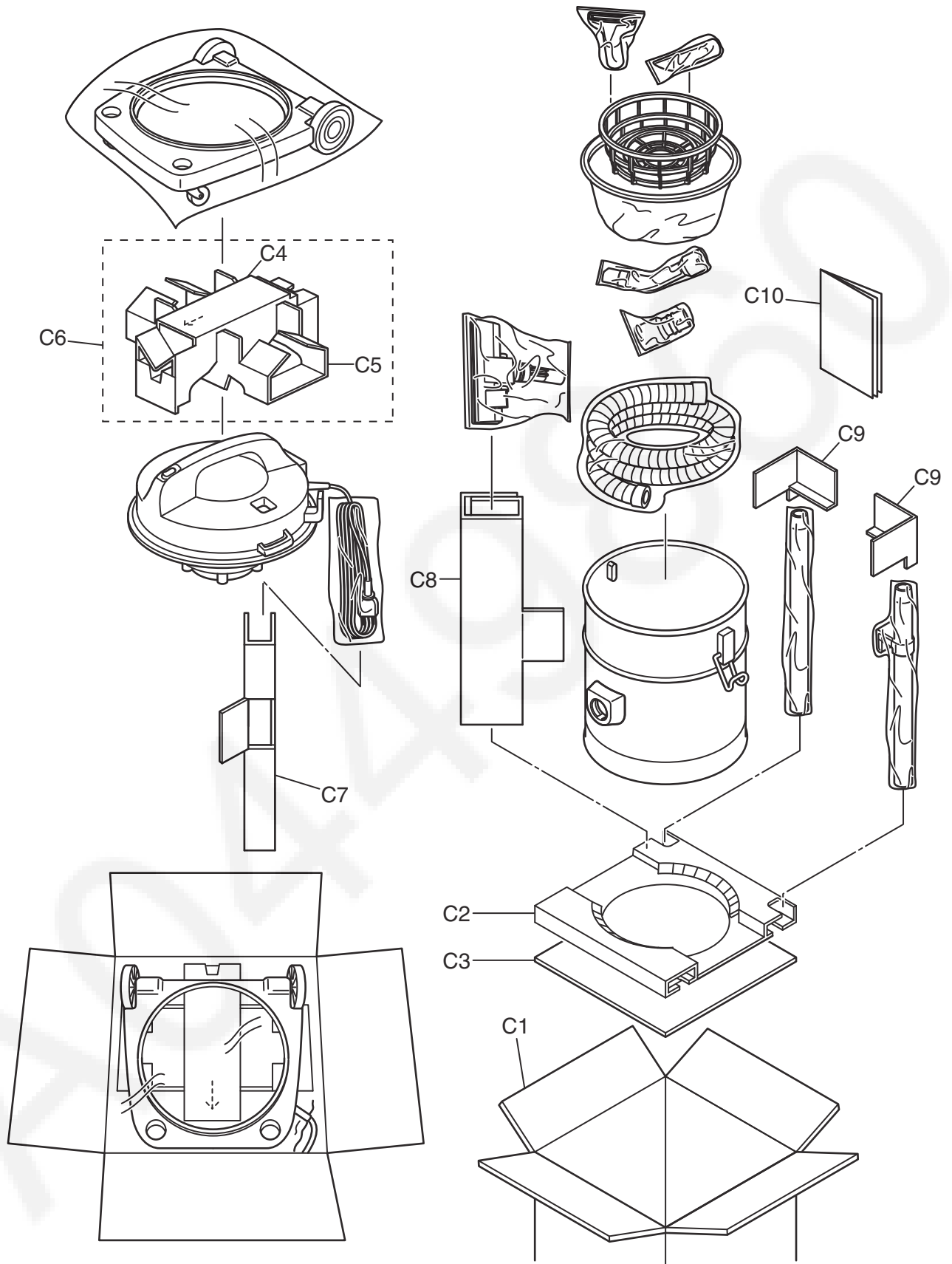

7.6. PACKING LIST

Safety	Ref.No	Service Parts No.	Part Name & Description	Q'TY	Remarks
	C1	AMV61Z990S0J	Individual Carton	1	
	C1	AMV61Z990SXJ	Individual Carton	1	Egypt only
	C2	AMC63Z-QN0	Bottom Plate	1	
	C3	AMC56Z-QN0	Cushion Bottom	1	
	C4	AMC70Z-QN0	Cushion B	1	
	C5	AMC69Z-QN0	Cushion A	1	
	C6	AMC98Z-QN0	Cushion Unit	1	
	C7	AMC68Z-QN0	Rear Protector	1	
	C8	AMC78Z-QN0	Supporter	1	
	C9	AMC72Z-QN0	Tiper	2	
	C10	AMV01Z99000J	Instruction Book	1	
	-	AMV10Z99000J	Body Bag	1	
	-	AMV19Z99000J	Cord Bag	1	