

Service Manual

Vacuum Cleaner

Model No. MC-YL635T146-BN
 MC-YL635T146-NP
 MC-YL635T147-AE
 MC-YL635T149-AE
 MC-YL635T149-EG
 MC-YL635T149-JO
 MC-YL635T149-LB
 MC-YL635T149-LY
 MC-YL635T149-OM
 MC-YL635T149-QA
 MC-YL635T747-KW
 MC-YL635T747-NG
 MC-YL635T747-SA
 MC-YL635TB41-TH
 MC-YL635TN46-VN

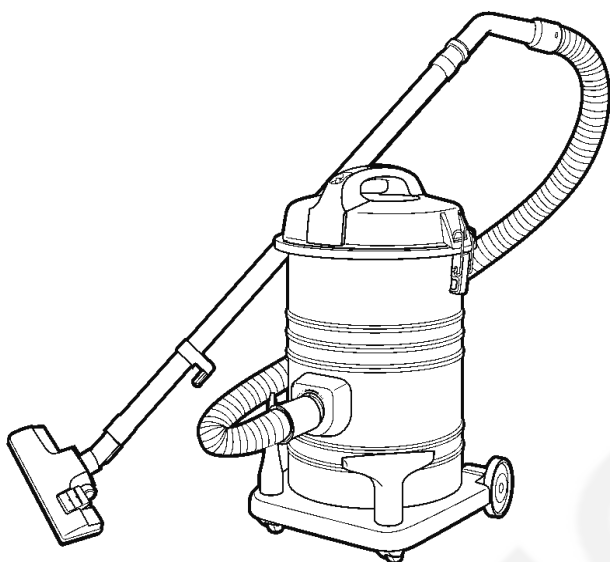

Destination : Brunei, Nepal, UAE, Egypt, Jordan,
 Lubnan, Libya, Oman, Qatar, Kuwait,
 Nigeria, Saudi Arabia, Thailand, Vietnam

⚠ WARNING

This service information is designed for experienced repair technicians only and is not designed for use by the general public. It does not contain warnings or cautions to advise non-technical individuals of potential dangers in attempting to service a product. Products powered by electricity should be serviced or repaired only by experienced professional technicians. Any attempt to service or repair the product or products dealt with in this service information by anyone else could result in serious injury or death.

IMPORTANT SAFETY NOTICE

There are special components used in this equipment which are important for safety. These parts are marked by **⚠** in the Schematic Diagrams, Circuit Board Diagrams, Exploded Views and Replacement Parts List. It is essential that these critical parts should be replaced with manufacturer's specified parts to prevent shock, fire or other hazards. Do not modify the original design without permission of manufacturer.

Panasonic[®]

© Panasonic Corporation 2016 Unauthorized copying and distribution is a violation of law.

TABLE OF CONTENTS

	PAGE
1 Specifications	3
2 Pictorial Diagram	3
3 Schematic Diagram	3
4 Disassembly and Assembly Instruction	4
4.1. Disassembly of Lower Body.....	4
4.2. Disassembly of Body Cover	4
4.3. Disassembly of Main Switch	5
4.4. Disassembly of Motor	6
5 Trouble Shooting Chart	7
6 Exploded View and Replacement Parts List	8
6.1. Exploded View	8
6.2. Attachment Exploded View	9
6.3. Packing Instruction.....	10
6.4. Replacement Parts List.....	11

1 Specifications

Model	MC-YL635 Series
Power Source	220 - 240V 50/60Hz (For Malaysia 240V - 50Hz)
In Power (Max)	2200W
In Power (IEC)	1550 - 1800W
Dimensions (L x W x H)mm	363mmX353mmX594mm
Nett Weight (kg)	5.8 kg
Dust Capacity (L)	21L
Cord Length	8m

2 Pictorial Diagram

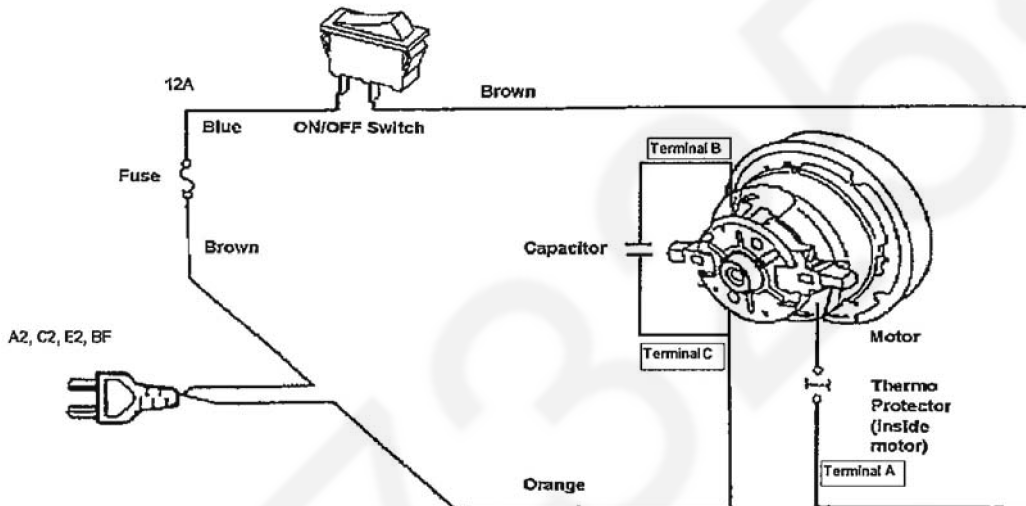

3 Schematic Diagram

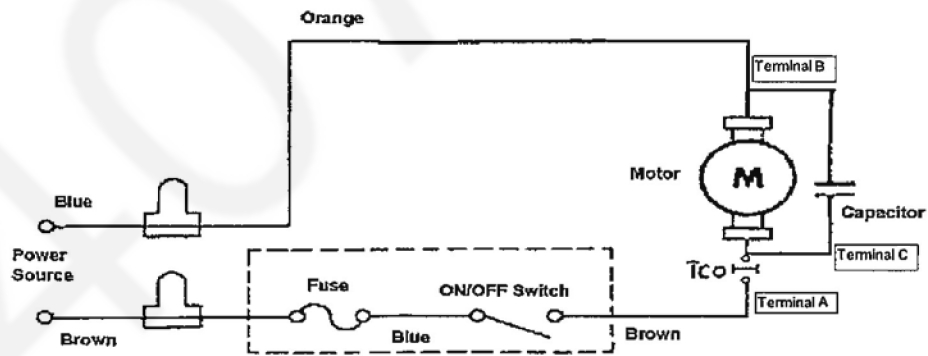

4 Disassembly and Assembly Instruction

4.1. Disassembly of Lower Body

Step 1 Release Buckles.



Step 2 Take out Body Cover from Lower Body.



4.2. Disassembly of Body Cover

Step 1 Remove 4 screws from Upper Body.

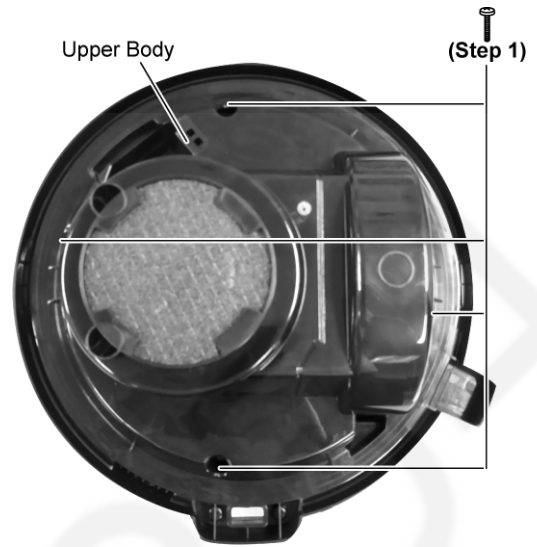

Step 2 Take out Body Cover from Upper Body.

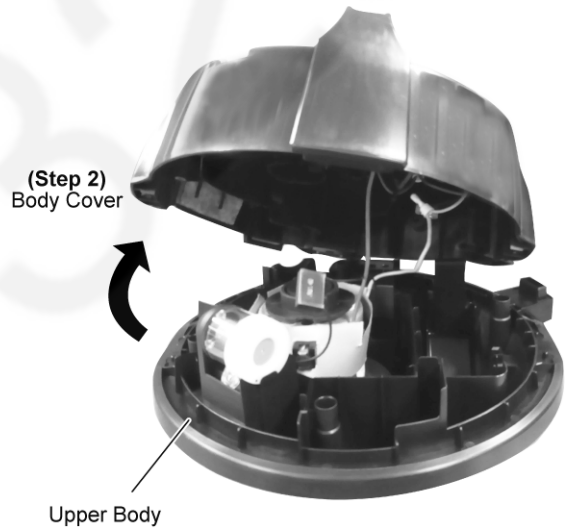

4.3. Disassembly of Main Switch

Step 1 Remove 2 screws from Body Cover.

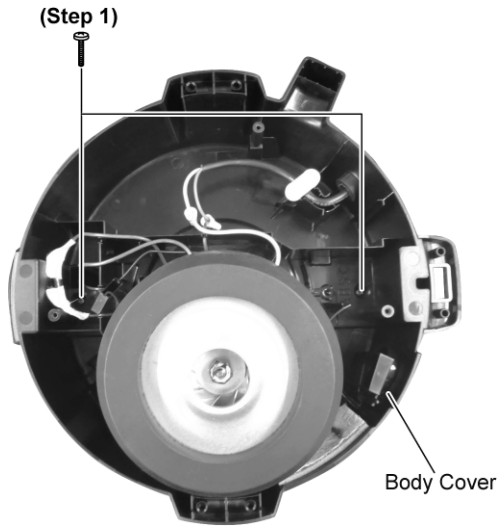

Step 3 Remove Main Switch from Body Cover.



Step 2 Take out Handle from Body Cover.



Step 4 Release Wires from Wire Holder.

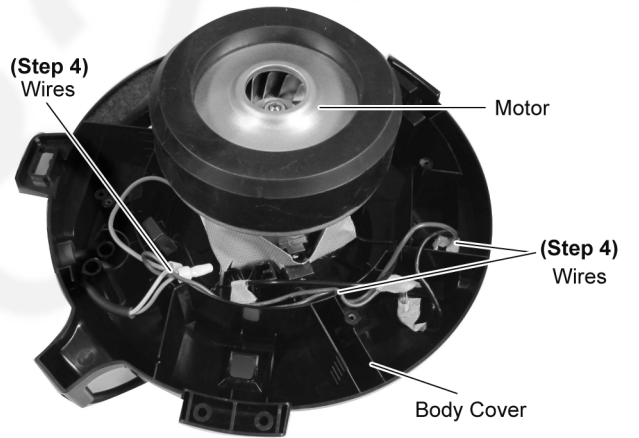

4.4. Disassembly of Motor

Step 1 Take out Silicon Cloth.

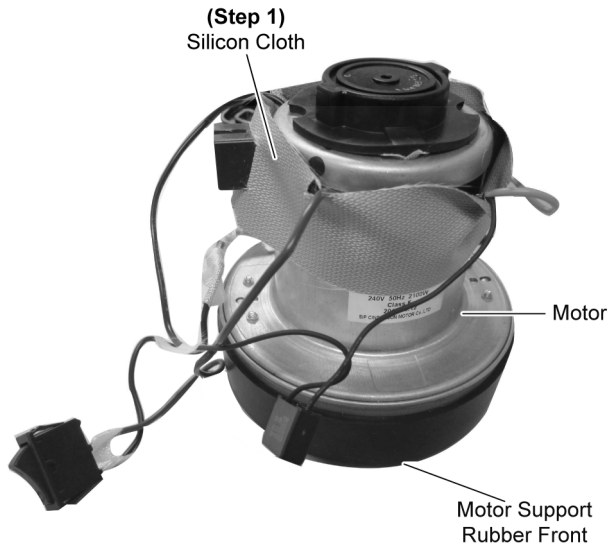

Step 2 Release Wire Connectors from Motor.

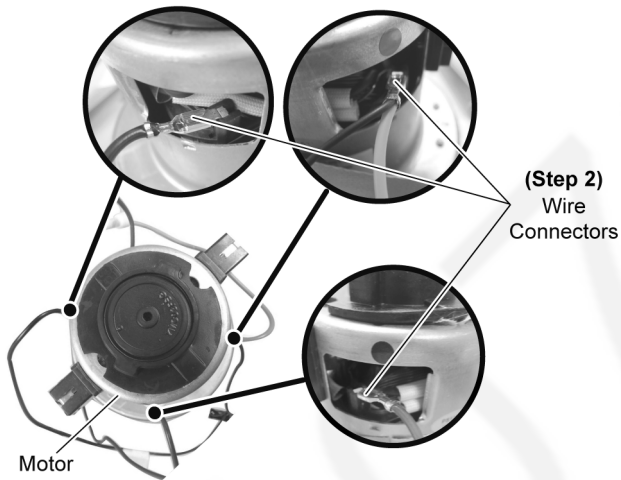

5 Trouble Shooting Chart

PROBLEM	POSSIBLE CAUSE	POSSIBLE SOLUTION
The appliance not operate.	1. Unplugged at socket outlet.	1. Plug in firmly, turn on the appliance.
Poor job of dirt pick-up.	1. Full or clogged Dust Box. 2. Clogged Nozzle. 3. Clogged Hose. 4. Hose not inserted fully. 5. Dirty Filters.	1. Empty the Dust Box. 2. Check for clogs. 3. Check for clogs. 4. Check Hose Connection. 5. Clean all the Filter.
The appliance stops during operation.	1. Full or clogged Dust Box. 2. Clogged Nozzle. 3. Clogged Hose. 4. Thermal protector tripped.	1. Empty the Dust Box. 2. Check for clogs. 3. Check for clogs. 4. Unplug the appliance, allow to cool and thermal protector will reset itself (Wait about 60 minutes).

6 Exploded View and Replacement Parts List

6.1. Exploded View

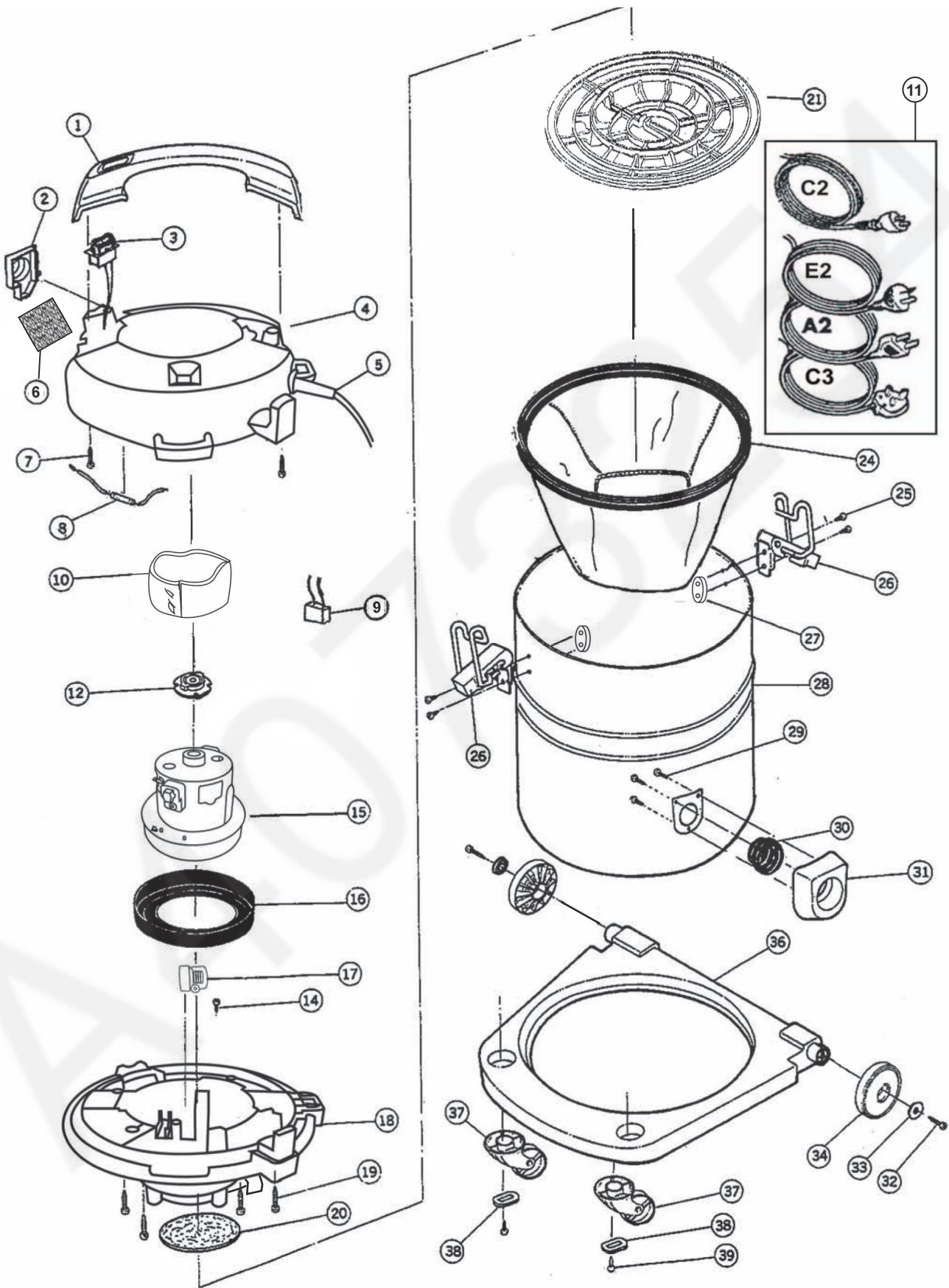

6.2. Attachment Exploded View

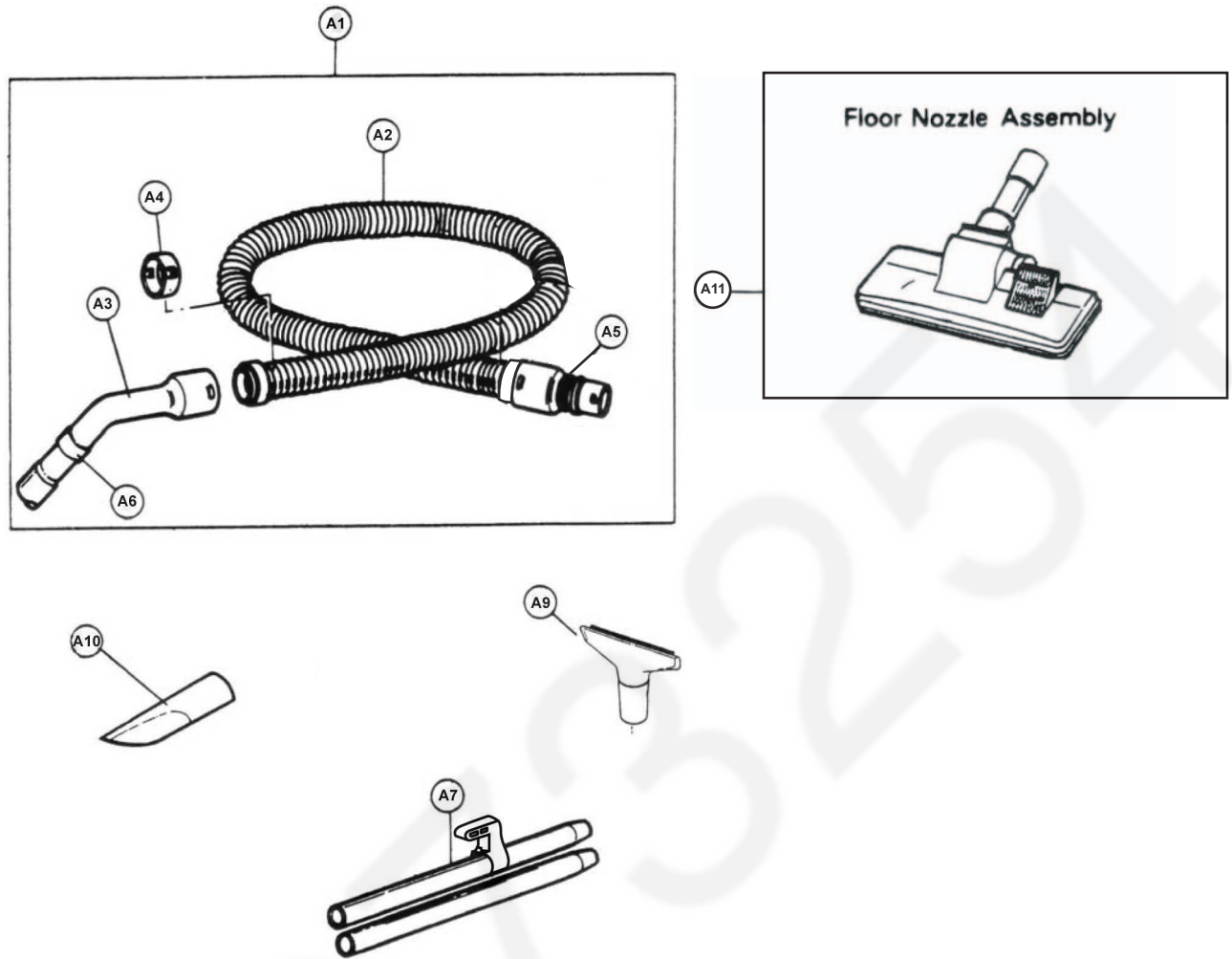

6.3. Packing Instruction

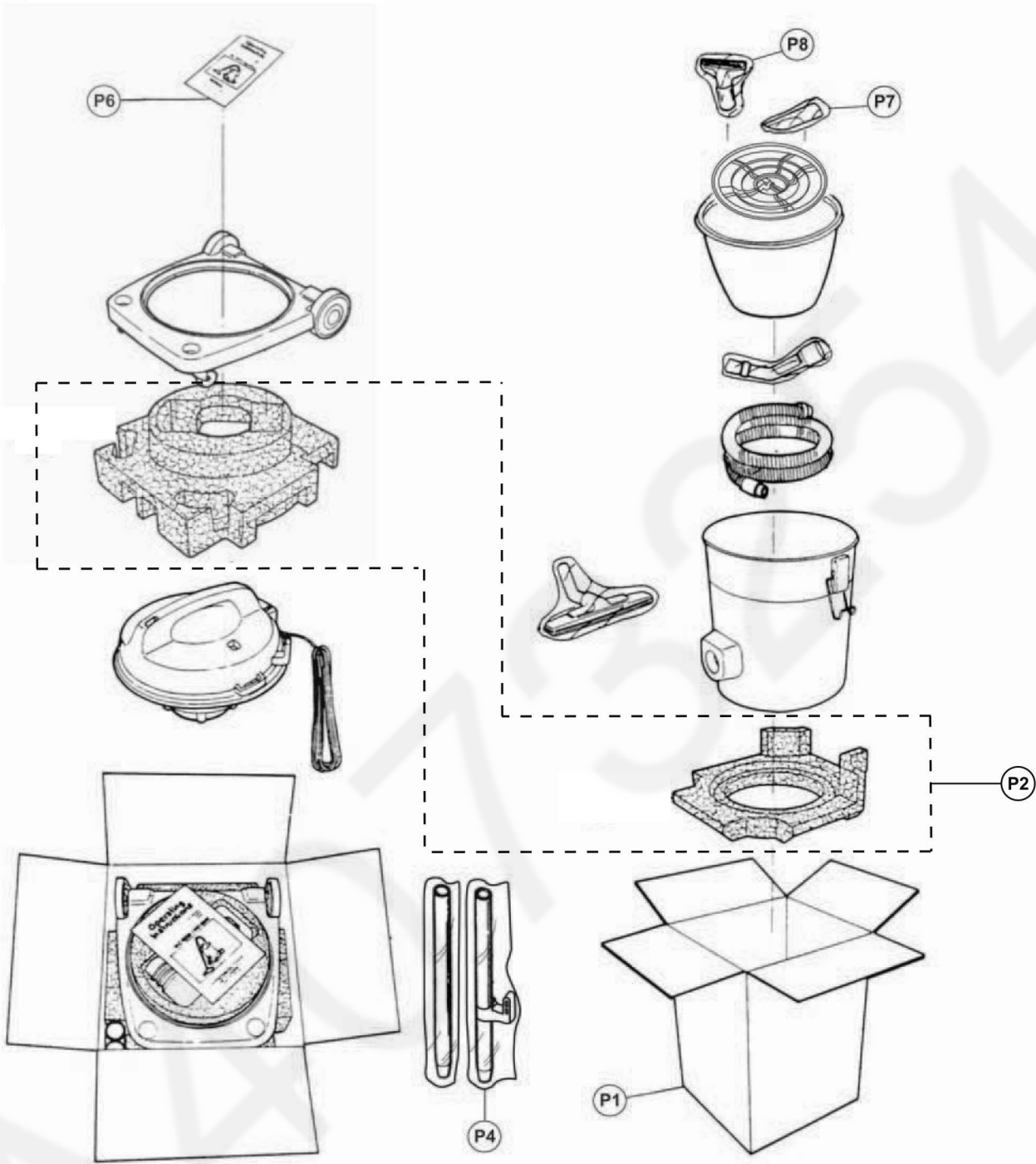

6.4. Replacement Parts List

Safety	Ref. No.	Part No.	Part Name & Description	Qty	Remarks
	1	YMV01BLD0K0	HANDLE	1	
	2	YMV96LLD0K0	BLOWER OULET UNIT	1	
△	3	YMV98ELE000	MAIN SWITCH	1	
	4	YMV24ALE0K0	BODY COVER	1	
	5	YMC51EBY000	CORD BUSHING	1	
	6	YMV85LLD000	EXHAUST PACKING UNIT	1	
	7	XTT4+20BFJ	TRUSS TAP SCREW	2	
△	8	YMV97W8100C	FUSE UNIT (12A)	1	
	9	YMV46F7A000	CAPACITOR OKAYA	1	
△	10	YMV0NA81100	SILICON CLOTH	1	
△	11	YMC97EVH10B-T	POWER CORD A2	1	MC-YL635TB41
△	11	YMC91EVG10E	POWER CORD E2	1	MC-YL635T149-AE, MC-YL635T149-EG, MC-YL635T149-JO, MC-YL635T149-LB
△	11	YMC96EVH10LT	POWER CORD C2	1	MC-YL635T146
△	11	YMC91EVG10ET	POWER CORD E2	1	MC-YL635T149-LY, OM, QA
△	11	YMC93EVG308-T	POWER CORD C3	1	MC-YL635T147, MC-YL635T747
△	11	YMC96EVH10L	POWER CORD C2	1	MC-YL635TN46
	12	YMC03FSG000	MOTOR SUPPORTER RUBBER REAR	1	
	14	XTN4+12BFJ	PAN SCREW	1	
△	15	YMV92F81205	FAN MOTOR UNIT	1	MC-YL635T147, MC-YL635T149, MC-YL635T747
△	15	YMV92F8120C	FAN MOTOR UNIT	1	MC-YL635T146, MC-YL635TB41, MC-YL635TN46
	16	YMC02FQU000	MOTOR SUPPORT RUBBER FRONT	1	
	17	YMV99MLD000	INDICATOR PIPE UNIT	1	
	18	YMV98ALE0K0	UPPER BODY UNIT	1	
	19	XTN4+20BFJ	PAN TAP SCREW	1	
	20	YMV30K81000	FILTER	1	
	21	YMV18KFP000	EXPANDER	1	
	24	YMV99K81000	CLOTH BAG UNIT	1	
	25	XTN4+16BFJ	PAN HEAD RECESS SCREW	4	
	26	YMV99D81000	BUCKLE UNIT	2	
	27	YMV32D81000	BUCKLE KNOB	2	
	28	YMV97ALE0L0-BA	LOWER BODY UNIT	1	
	29	XTT35+16BFJ	TRUSS TAP SCREW	3	
	30	YMV50KLD000	VALVE GRAMMET	1	
	31	YMV01HLD0K0	FRONT COVER	1	
	32	XTN4+16BFJ	PAN TAP SCREW	2	
	33	YMV05CLD0K0	WHEEL CAP	2	
	34	YMV01CFP0V0	WHEEL	2	
	36	YMC43A0E0K0	FRAME	1	
	37	YMC95C0E1H0	CASTER UNIT	2	
	38	YMC26CB0100	WASHER	2	
	39	XTN4+16BFJ	PAN TAP SCREW	2	
			Attachment List		
	A1	YMV94PLD0K0-P	HOSE ASSY (1.4M)	1	
	A2	YMV01PBW000	HOSE	1	
△	A3	YMC98P4Y200	CURVED PIPE UNIT	1	
	A4	YMC24P0R1V0	HOSE SUPPORTER GREY	2	
	A5	YMV02PLD0K0	CONNECTION PIPE	1	
	A6	YMC54P7K060	SUCTION REGULATOR	1	
△	A7	YMV99PBA000	EXTENSION WAND ASS'Y	1	METAL
	A9	YMV86R81100	UPHOLSTERY NOZZLE UNIT	1	
	A10	YMC60R0G3V0	CREVICE NOZZLE	1	
	A11	YMV99RFP200	FLOOR NOZZLE ASSY	1	

Safety	Ref. No.	Part No.	Part Name & Description	Qty	Remarks
			PACKING LIST		
	P1	YMV61ZLE000	INDIVIDUAL CARTON	1	
	P2	YMV98ZLD000	CUSHION UNIT	1	
	P4	YMV14Z81000	EXTENSION WAND BAG	1	
△	P6	YMV01ZLD005	INSTRUCTION BOOK	1	ENGLISH, VIETNAM, THAILAND
△	P6	YMV01ZLD00B	INSTRUCTION BOOK	1	ENGLISH, ARAB, PERSIAN
	P7	YMV20Z81100	CREVICE NOZZLE BAG	1	
	P8	YMV37Z8110	UPHOSTERY NOZZLE BAG	1	

MMH1301