

Service Manual

Vacuum Cleaner

Model No. **MC-YL623G147-AE**

MC-YL623G149-AE

MC-YL623G747-SA

MC-YL623G149-QA

MC-YL623G447-HK

MC-YL623G747-NG

MC-YL623G149-LY

MC-YL623G149-EG

MC-YL623G149-JO

MC-YL623G149-LB

MC-YL623G747-KW

MC-YL623G149-FJ

MC-YL623G149-OM

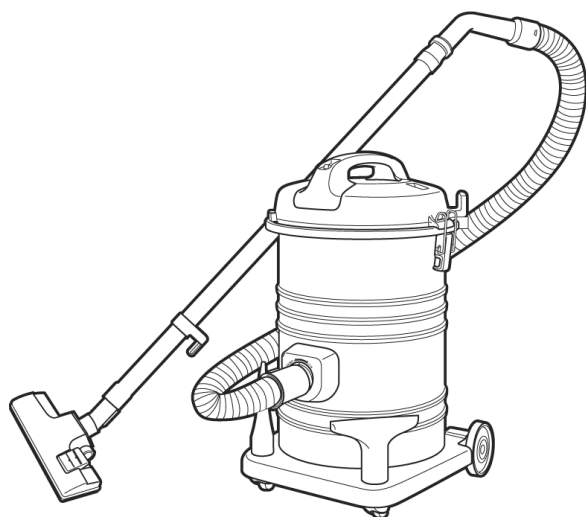

Destination : UAE, SAUDI ARABIA, QATAR, HONG KONG, NIGERIA, LIBYA, EGYPT, JORDAN, LEBANON, KUWAIT, FIJI & OMAN

⚠ WARNING

This service information is designed for experienced repair technicians only and is not designed for use by the general public. It does not contain warnings or cautions to advise non-technical individuals of potential dangers in attempting to service a product. Products powered by electricity should be serviced or repaired only by experienced professional technicians. Any attempt to service or repair the product or products dealt with in this service information by anyone else could result in serious injury or death.

IMPORTANT SAFETY NOTICE

There are special components used in this equipment which are important for safety. These parts are marked by **⚠** in the Schematic Diagrams, Circuit Board Diagrams, Exploded Views and Replacement Parts List. It is essential that these critical parts should be replaced with manufacturer's specified parts to prevent shock, fire or other hazards. Do not modify the original design without permission of manufacturer.

TABLE OF CONTENTS

	PAGE		PAGE
1 Specifications	3	3 Schematic Diagram	3
2 Pictorial Diagram	3	4 Disassembly and Assembly Instruction	4

Panasonic®

© 2012 Panasonic Manufacturing Malaysia Berhad (6100-K). Unauthorized copying and distribution is a violation of law.

4.1. Disassembly of Lower Body-----	4
4.2. Disassembly of Body Cover-----	4
4.3. Disassembly of Main Switch Ass'y-----	5
4.4. Disassembly of Motor-----	6
5 Trouble Shooting Chart-----	7
6 Exploded View and Replacement Parts List-----	8
6.1. Exploded View-----	8
6.2. Attachment Exploded View-----	9
6.3. Packing Instruction-----	10
6.4. Replacement Parts List-----	11

1 Specifications

Model	MC-YL623G Series
Power Source	220 - 240V
Frequency (Hz)	50/60Hz, 50Hz
Motor Power	1800W
Dimensions (L x W x H)	366mmX340mmX544mm
Net Weight (kg)	6.9 kg
Extension Wands	Metal
Floor Nozzle	Bottom Plastic
Attachments	Hose, Extension Wand, Floor Nozzle, Curved Ward, Crevice Nozzle, Upholstery Nozzle

2 Pictorial Diagram

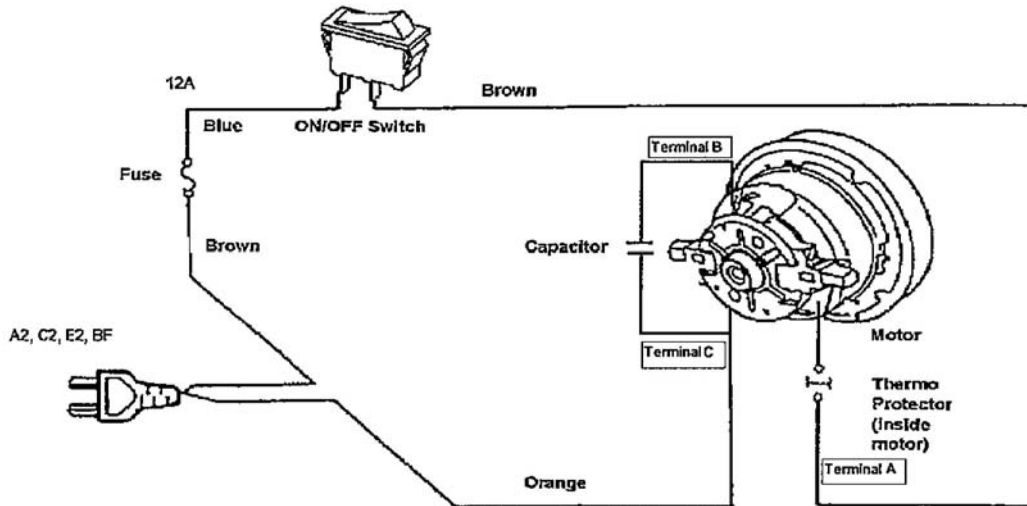

3 Schematic Diagram

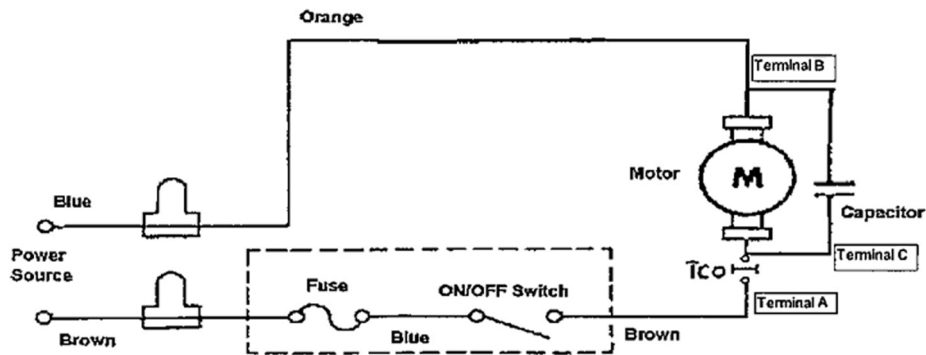

4 Disassembly and Assembly Instruction

4.1. Disassembly of Lower Body

Step 1 Release Buckles.

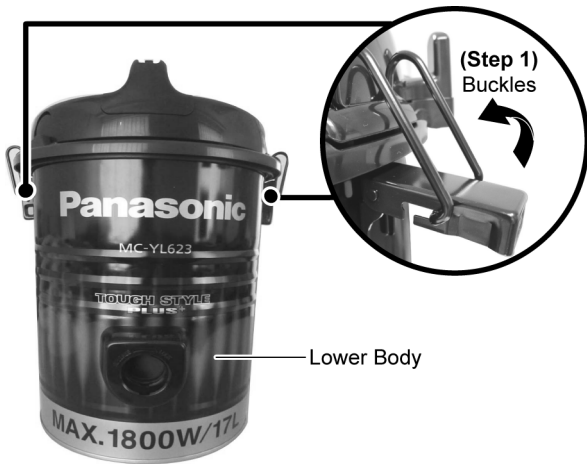

Step 2 Take out Body Cover from Lower Body.



4.2. Disassembly of Body Cover

Step 1 Remove 4 screws from Upper Body.

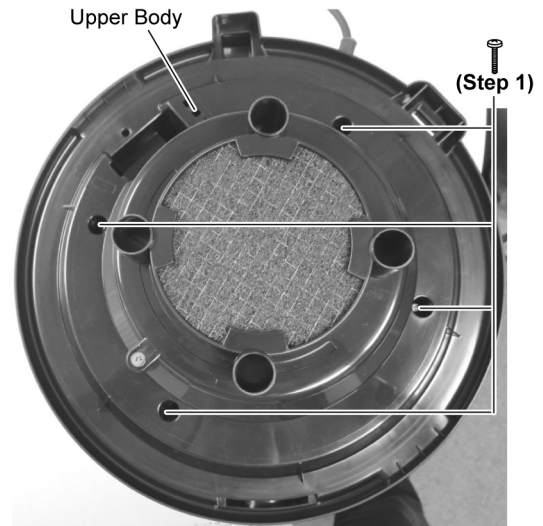

Step 2 Take out Body Cover from Upper Body.

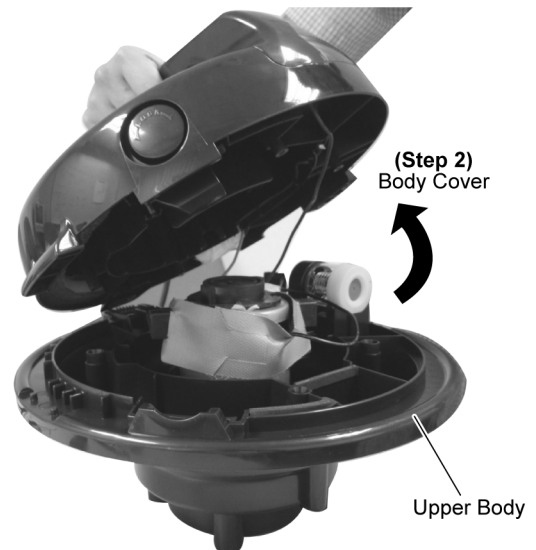

4.3. Disassembly of Main Switch Ass'y

Step 1 Remove 2 screws from Body Cover.

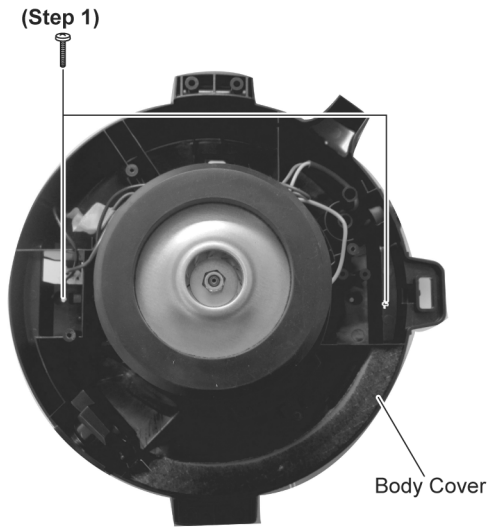

Step 2 Take out Handle from Body Cover.

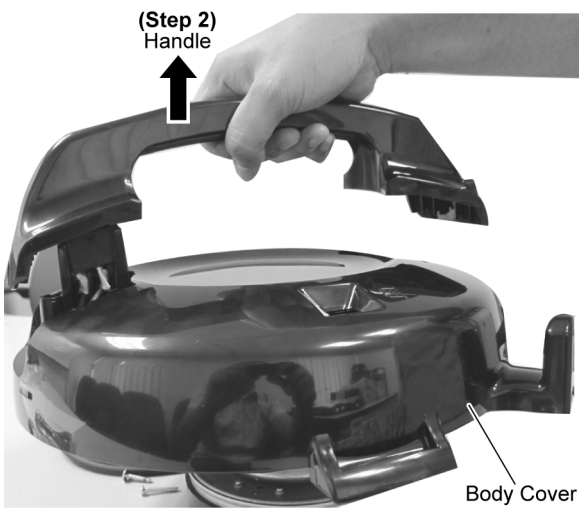

Step 3 Remove Main Switch Assy from Body Cover.



Step 4 Release Wires from Wire Holder.

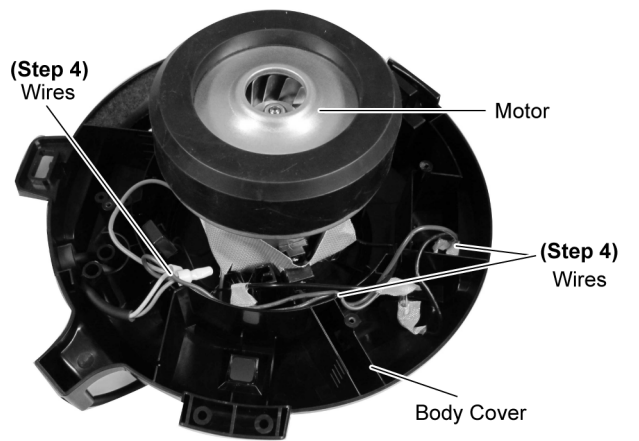

4.4. Disassembly of Motor

Step 1 Take out Silicon Cloth.

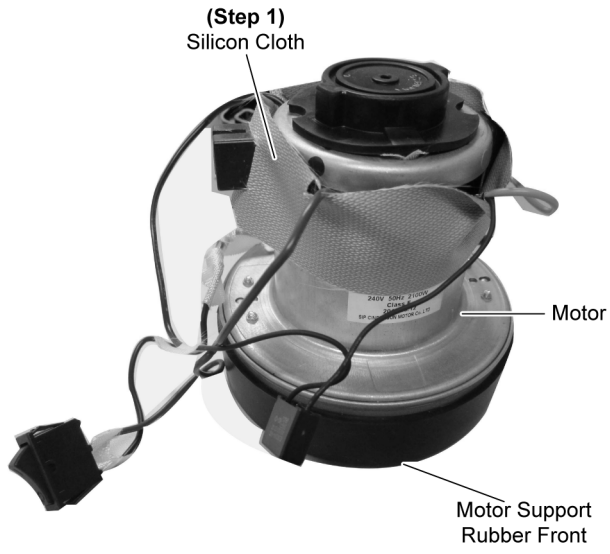

Step 2 Release Wire Connectors from Motor.

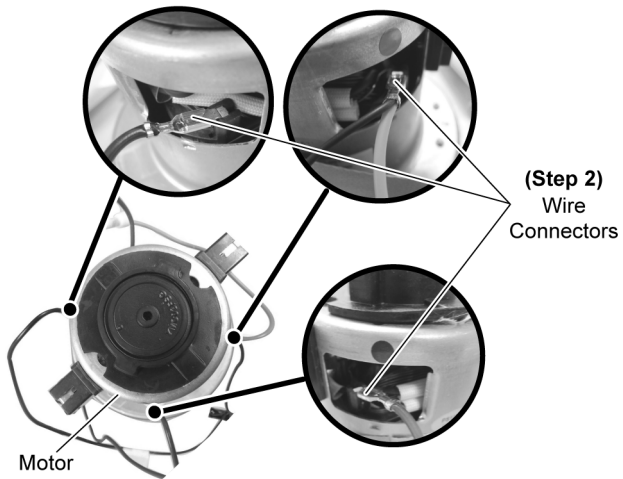

5 Trouble Shooting Chart

PROBLEM	POSSIBLE CAUSE	POSSIBLE SOLUTION
The appliance not operate.	1. Unplugged at socket outlet.	1. Plug in firmly, turn on the appliance.
Poor job of dirt pick-up.	1. Full or clogged Dust Box. 2. Clogged Nozzle. 3. Clogged Hose. 4. Hose not inserted fully. 5. Dirty Filters.	1. Empty the Dust Box. 2. Check for clogs. 3. Check for clogs. 4. Check Hose Connection. 5. Clean all the Filter.
The appliance stops during operation.	1. Full or clogged Dust Box. 2. Clogged Nozzle. 3. Clogged Hose. 4. Thermal protector tripped.	1. Empty the Dust Box. 2. Check for clogs. 3. Check for clogs. 4. Unplug the appliance, allow to cool and thermal protector will reset itself (Wait about 60 minutes).

6 Exploded View and Replacement Parts List

6.1. Exploded View

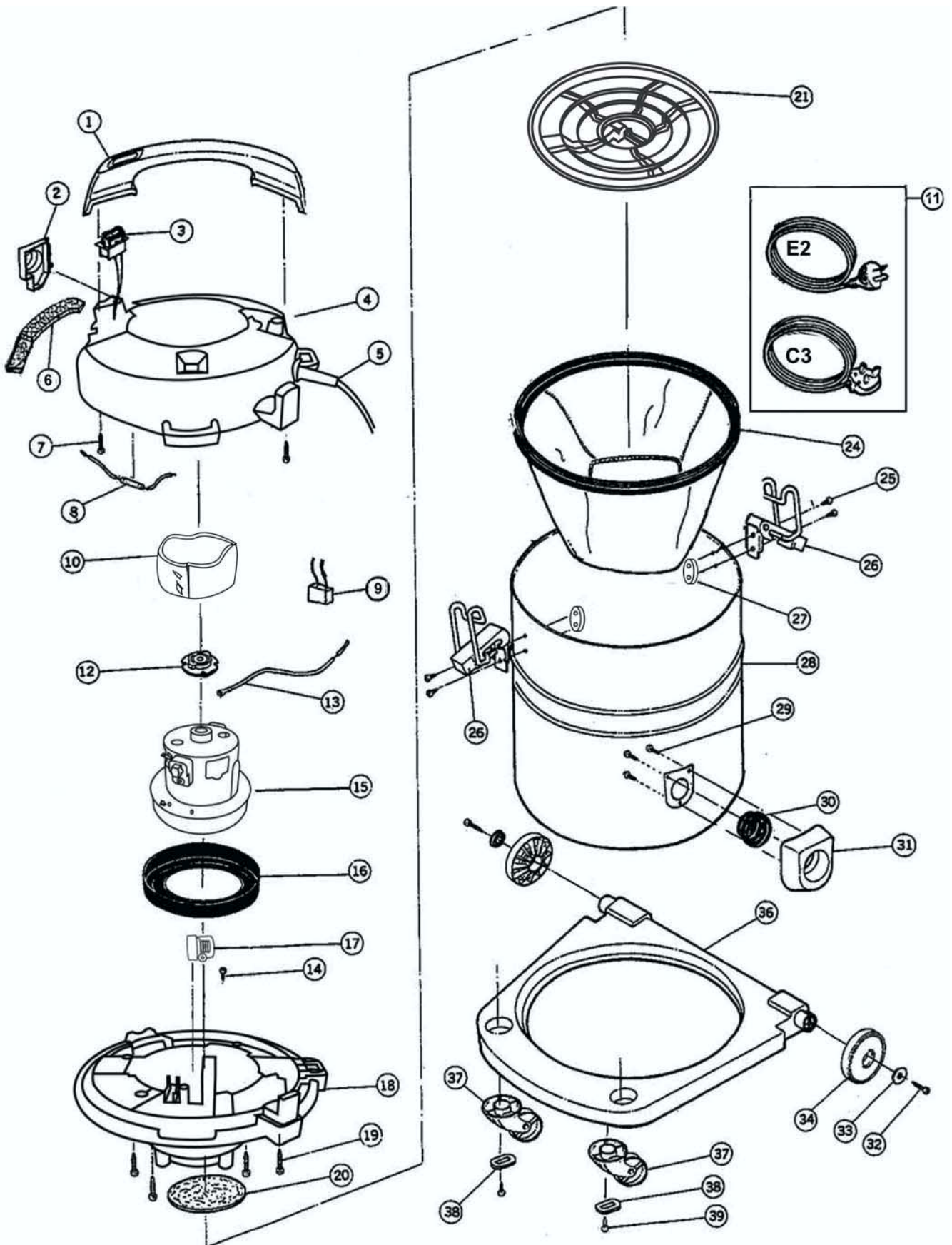

6.2. Attachment Exploded View

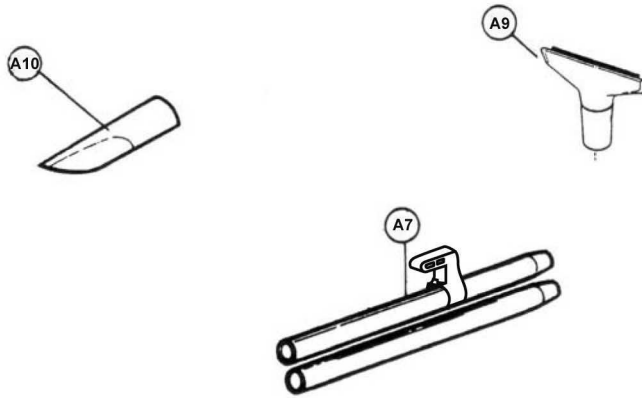
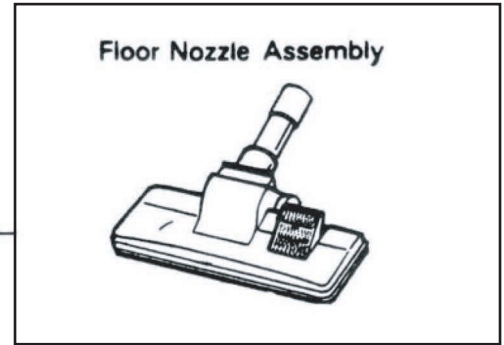
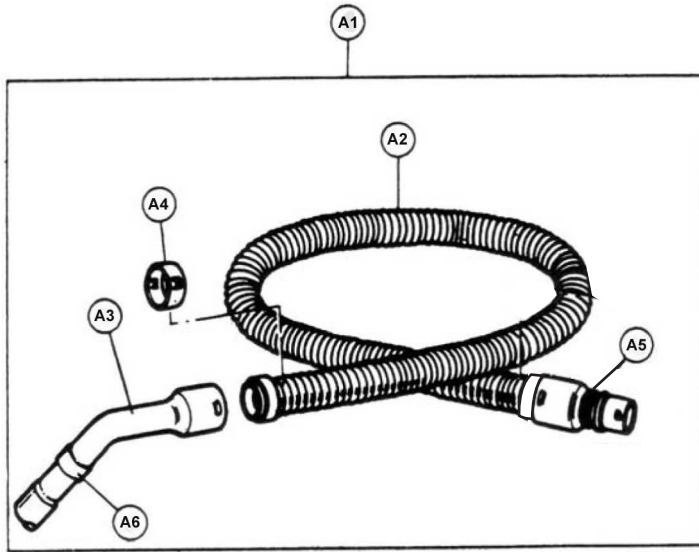

6.3. Packing Instruction

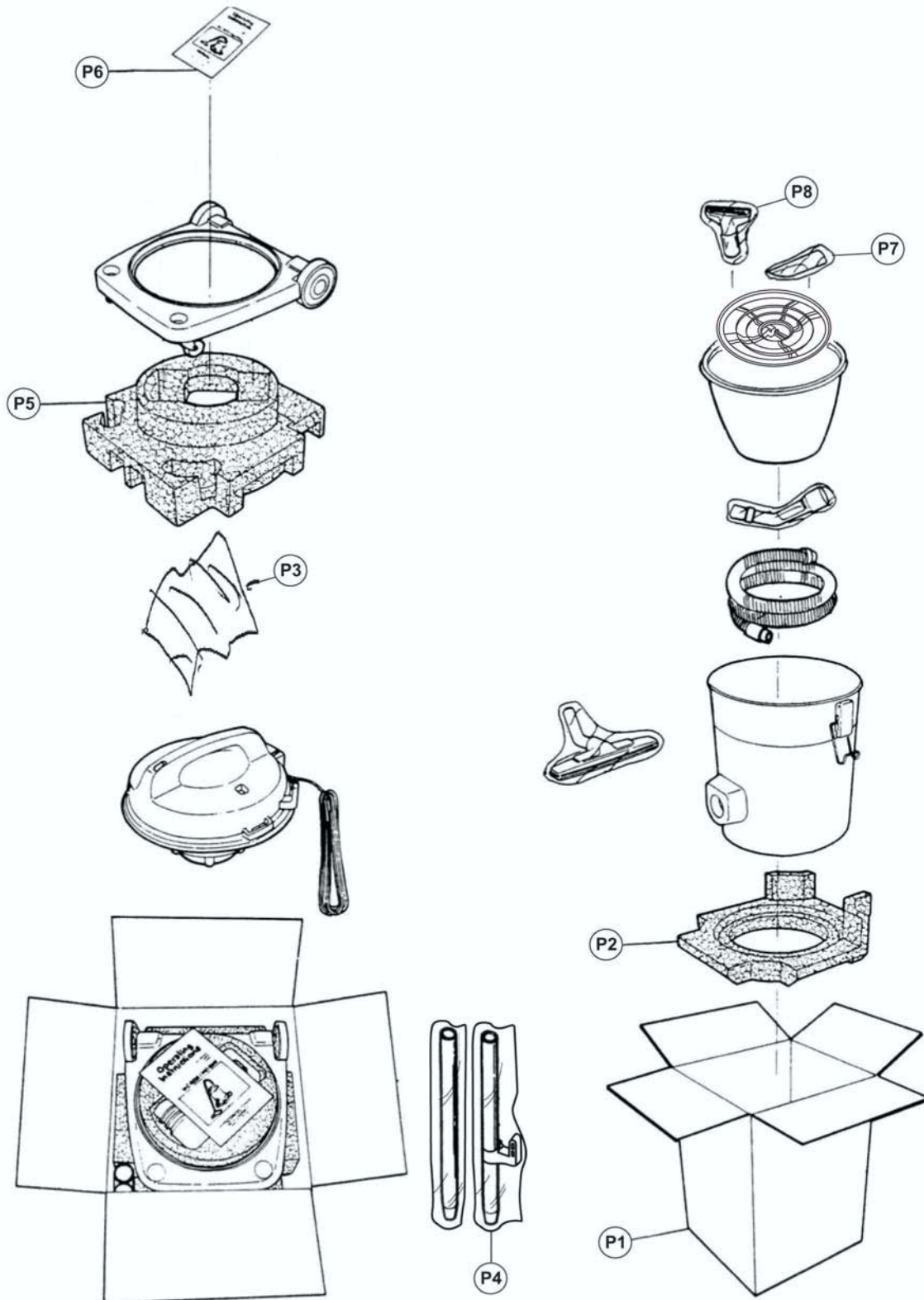

6.4. Replacement Parts List

Safety	Ref. No.	Part No.	Part Name & Description	Qty	Remarks
	1	YMV01B810K0	HANDLE	1	
	2	YMC96LDD1V0	BLOWER OULET UNIT	1	
	3	YMV98E8110C	MAIN SWITCH ASSY	1	
	4	YMV24A810K0	BODY COVER	1	
	5	YMC51EBY000	CORD BUSHING	1	
	6	YMC30LNS000	OUTLET FILTER	1	
	7	XTT4+20BFJ	TRUSS TAP SCREW	2	
	8	YMV97W8100C	FUSE ASSY (12A)	1	
	9	YMV46F61000	CAPACITOR (0.22)	1	
	10	YMV0NA81100	SILICON CLOTH	1	
	11	YMC93EVG208-T	POWER CORD W/PLUG C3 (1.00mm ²)	1	MC-YL623G147-AE, MC-YL623G747-SA, MC-YL623G747-NG, MC-YL623G747-KW, MC-YL623G447-HK
	11	YMC91EVG10E	POWER CORD W/PLUG E2 (1.00mm ²)	1	MC-YL623G149-AE, MC-YL623G149-LY, MC-YL623G149-LB, MC-YL623G149-JO, MC-YL623G149-EG, MC-YL623G149-QA, MC-YL623G149-OM, MC-YL623G149-FJ
	12	YMC03FSG000	MOTOR SUPPORTER RUBBER REAR	1	
	13	YMR083R170U	BLACK LEAD WIRE	1	
	14	XTN4+12BFJ	PAN SCREW	1	
	15	YMV92F8010C	FAN MOTOR UNIT (1904W)	1	
	16	YMC02FQU000	MOTOR SUPPORT RUBBER FRONT	1	
	17	YMV99M7Y104	INDICATOR PIPE UNIT	1	
	18	YMV98A7Y000	UPPER BODY UNIT	1	
	19	XTN4+25BFJ	PAN HEAD RECESS SCREW	4	
	20	YMV30K81000	FILTER	1	
	21	YMV18KFP000	EXPANDER	1	
	24	YMV99K81000	CLOTH BAG UNIT	1	
	25	XTN4+16BFJ	PAN HEAD RECESS SCREW	4	
	26	YMV99D81000	BUCKLE UNIT	2	
	27	YMV32D81000	BUCKLE KNOB	2	
	28	YMV97AG50G0	LOWER BODY UNIT	1	
	29	XTT35+16BFJ	TRUSS TAP SCREW	3	
	30	YMC50KJ3100	VALVE GRAMMET	1	
	31	YMC01HDD0K0	FRONT COVER	1	
	32	XTN4+16BFJ	PAN TAP SCREW	2	
	33	YMC05CL91H0	WHEEL CAP	2	
	34	YMV01CFP0V0	WHEEL	2	
	36	YMV43AG30K0	FRAME	1	
	37	YMC95C0E1H0	CASTER UNIT	2	
	38	YMC26CB0100	WASHER	2	
	39	XTN4+16BFJ	PAN TAP SCREW	2	
			Attachment List		
	A1	YMV94PFP0V0-P	HOSE ASSY (1.4M)	1	
	A2	YMV01PBW000	HOSE	1	
	A3	YMC98P4Y200	CURVED WAND ASSY	1	
	A4	YMC24P0R1V0	HOSE SUPPORTER	2	
	A5	YMV02PFP0V0	CONNECTION PIPE	1	
	A6	YMC54P7K0V0	SUCTION REGULATOR	1	
	A7	YMV99PBA000	EXTENSION WAND ASSY	1	METAL
	A9	YMV86R81100	UPHOLSTERY NOZZLE UNIT	1	
	A10	YMC60R0G3V0	CREVICE NOZZLE	1	
	A11	YMC99RXQ100	FLOOR NOZZLE ASSY	1	
			PACKING LIST		
	P1	YMV61ZG500C	CARTON BOX	1	
	P2	YMV70Z81000	CUSHION BOTTOM	1	

Safety	Ref. No.	Part No.	Part Name & Description	Qty	Remarks
	P3	YMC76ZXQ100	PE LINER	1	
	P4	YMV14Z7Z000	EXTENSION WAND BAG	1	
	P5	YMV69Z81000	CUSHION TOP	1	
	P6	YMV01ZFP100	INSTRUCTION MANUAL	1	
	P6	YMV01ZG4000	INSTRUCTION MANUAL	1	MC-YL623G447-HK ONLY
	P7	YMV20Z81100	CREVICE NOZZLE BAG	1	
	P8	YMV37Z81100	UPHOSTERY NOZZLE BAG	1	

MMH1212