

Service Manual

Vacuum Cleaner

Model No. **MC-CJ915-R747**
MC-CJ915-R149
MC-CJ915-R147
MC-CJ915-W747
MC-CJ915-W149
MC-CJ915-W147

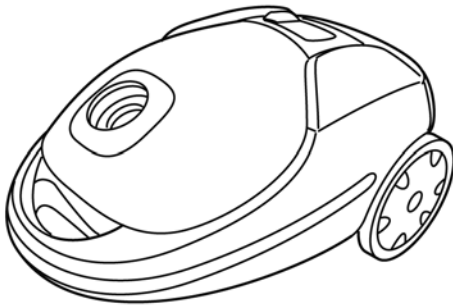

Product Color : (R) Red , (W) White

Destination : 1.Saudi Arabia, Kuwait

MC-CJ915-R747

MC-CJ915-W747

2.Iran

MC-CJ915-R149

MC-CJ915-W149

3.UAE

MC-CJ915-R147

MC-CJ915-W147

WARNING

This service information is designed for experienced repair technicians only and is not designed for use by the general public. It does not contain warnings or cautions to advise non-technical individuals of potential dangers in attempting to service a product. Products powered by electricity should be serviced or repaired only by experienced professional technicians. Any attempt to service or repair the product or products dealt with in this service information by anyone else could result in serious injury or death.

IMPORTANT SAFETY NOTICE

There are special components used in this equipment which are important for safety. These parts are marked by  in the Schematic Diagrams, Circuit Board Diagrams, Exploded Views and Replacement Parts List. It is essential that these critical parts should be replaced with manufacturer's specified parts to prevent shock, fire or other hazards. Do not modify the original design without permission of manufacturer.

Panasonic[®]

© Panasonic Corporation 2012 Unauthorized copying and distribution is a violation of law.

TABLE OF CONTENTS

	PAGE	PAGE
1 Specifications	3	
2 Location of Controls and Components	4	
3 Troubleshooting Guide	5	
4 Disassembly and Assembly Instructions	7	
4.1. Disassembly of the Dust Cover Assy	7	
4.2. Disassembly of the Dust Bag Holder	8	
4.3. Disassembly of Body Cover Assy, Switch Pedal, Cord Rewind Button	9	
4.4. Disassembly of Upper Body, Handle Cover, and Guide Lever	10	
4.5. Disassembly of Motor Case Set	12	
4.6. Disassembly of Cord Reel Unit	12	
4.7. Disassembly of Rail Base Unit	13	
4.8. Disassembly of Fan Motor Unit	13	
4.9. Disassembly of P.C.B. Assy	15	
4.10. Replacement of Blower Cover	16	
5 Wiring Connection Diagram	17	
6 Exploded View and Replacement Parts List	18	
6.1. EXPLODED VIEW (ATTACHMENTS)	18	
6.2. PARTS LIST (ATTACHMENTS)	19	
6.3. EXPLODED VIEW (BODY UNIT)	20	
6.4. PARTS LIST (BODY UNIT)	21	

1 Specifications

Model No.	MC-CJ915
Power source	220V-240V ~ 50/60Hz
Max. input	2100W
Nominal input	1550-1900W
Dimensions (WxLxH)	320mm x 500mm x 265mm
Net weight	6.1kg
Cord length	5m
Extension Wand	Telescopic(Magic Telescopic Wand)
Nozzle	Floor nozzle(3D EZ nozzle)
Crevice nozzle	1
Dusting brush	1

2 Location of Controls and Components

First, assemble the parts together. (Hose, Telescopic wand, Floor nozzle)

Parts are set surely so as not to come off.

Connect the edge of the hose and the upper end of the telescopic wand by inserting one into the other and twisting together.

Attach the floor nozzle to the other end while aligning the raised section with the hole.

(When removing them, push the tab down while pulling on the telescopic wand.)



Alternative nozzles

Crevice nozzle:
For narrow gaps, etc.

Dusting brush:
For furniture, venetian blinds, etc.

2 Adjust the nozzle to suit the floor

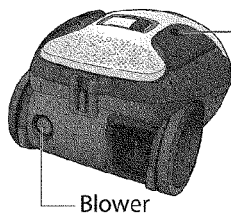
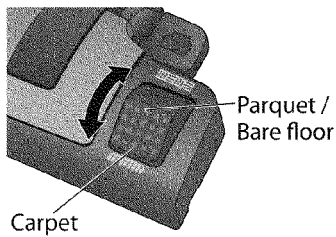

Cord rewind pedal
Press the mark, not the edge of the pedal.

Blower

Telescopic wand
Length may be adjusted.

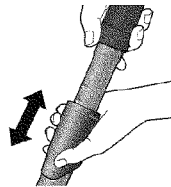

Release pedal

Release pedal

**Floor nozzle
(3D EZ Nozzle)**

Suction regulator
Use when strong suction causes the nozzle to stick to the floor, hindering movement.

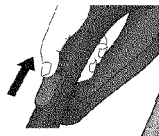

Hose

Variable Power control

ON/OFF Switch pedal

Plug

Dust cover

Power cord

Cloth dust bag (in body)

Dust indicator

Turn the power control to the highest setting and lift the nozzle off the floor.
If the dust indicator turns red, the cloth dust bag is full and requires replacing the cloth dust bag.

How to use Blower

For locations where the nozzle will not enter, connect the hose to the blower and blow the dust out.

Step 1

Turn off the appliance, release the connection pipe from hose inlet. Connect the hose to the blower.

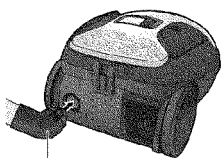

Connection pipe

Step 2

Turn on the appliance and blow the dust out.

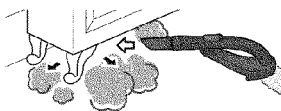

Step 3

Turn off the appliance, connect the connection pipe to the hose inlet. After this, turn on the appliance and clean the dust.



Hose inlet

How to use 3D EZ Nozzle

Remove the floor nozzle by pressing the release pedal and you can use EZ Crevice or EZ Upholstery easily anytime.

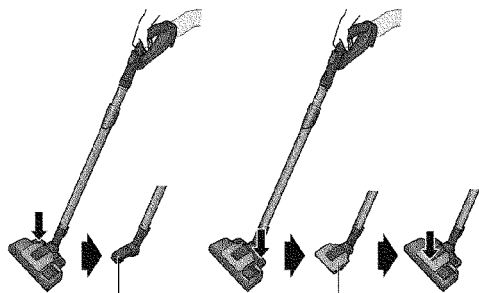

EZ Crevice
For narrow gaps, etc.

EZ Upholstery
For sofa, etc.

1 Start operation

Press

Press the mark, not the edge of the pedal.

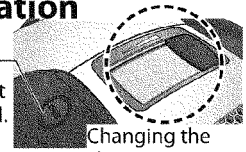

Changing the cleaning power.

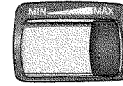

To increase or decrease the power, slide the variable power control.

3 Troubleshooting Guide

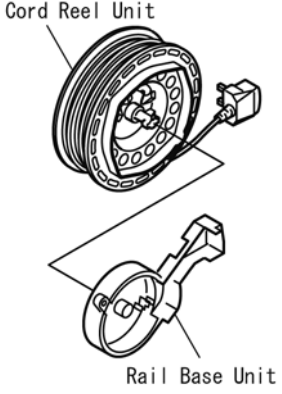
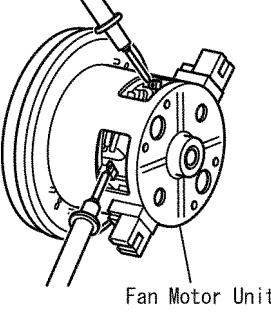
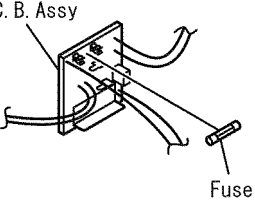
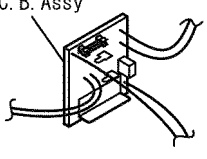
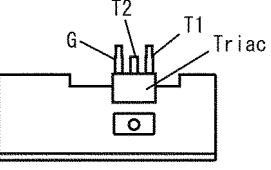
CONDITION	CHECKPOINT	FIGURE	CHECK METHOD	REMEDY
The Motor doesn't rotate.	CORD REEL UNIT RAIL BASE UNIT	 <p>Cord Reel Unit</p> <p>Rail Base Unit</p>	<ul style="list-style-type: none"> • Check the continuity at both ends of the Plug and both ends of the Lead Wire Terminal of the Cord Reel Unit. (Disconnection check) • There must be no problems between the Cord Reel Unit and the Rail Base Unit (e.g. burns in the contact, entry of dust). 	<ul style="list-style-type: none"> • If there is no continuity, replace the Cord Reel Unit, or the Rail Base Unit.
MOTOR		 <p>Fan Motor Unit</p>	<ul style="list-style-type: none"> • Check the continuity between the terminals of the Motor. • Confirm that the Motor can be rotated by fingers without being locked. • Visually check for burns in the Motor (e.g. burns in the coil). 	<ul style="list-style-type: none"> • If there is a problem, replace the Fan Motor Unit. • * Also check and replace the Fuse.(on the P.C.B. Assy)
FUSE		 <p>P. C. B. Assy</p> <p>Fuse</p>	<ul style="list-style-type: none"> • Check if the Fuse has blown. Causes of fuse blowing: <ol style="list-style-type: none"> 1. Overcurrent 2. Burn of the Motor 3. Short-circuiting due to incorrect wiring 	<ul style="list-style-type: none"> • If the Fuse has blown, remove the cause and replace the Fuse. • *If a burn in the Motor caused the Fuse to blow, then also replace the Motor.
P.C.B. ASSY		 <p>P. C. B. Assy</p>	<ul style="list-style-type: none"> • Check the internal components for problems. (Burnt, melted, broken, etc.) • There must be no broken foil of the Printed Circuit Board. • There must be no breaks in the Lead Wires. 	<ul style="list-style-type: none"> • If there is a problem, replace the P.C.B. Assy.
TRIAC (on the P.C.B. Assy)		 <p>G</p> <p>T2</p> <p>T1</p> <p>Triac</p>	<ul style="list-style-type: none"> • Check the Triac by conducting the following inspection. <div style="background-color: black; color: white; padding: 5px; text-align: center; font-weight: bold;"> Check the Triac on the P.C.B. Assy </div> <p>*Using a tester, see if continuity is detected between each pair of Triac legs. The normality are as follows.</p> <ol style="list-style-type: none"> 1. T1 - T2 : No continuity 2. T2 - G : No continuity 3. T1 - G : Continuity <p>*Connect the T1 side to the positive side of the tester, and then check the continuity.</p>	<ul style="list-style-type: none"> • If there is a problem, replace the P.C.B. Assy.

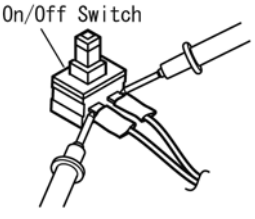
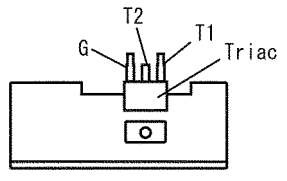
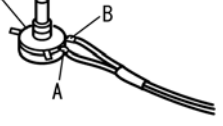
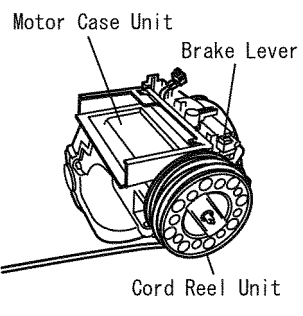
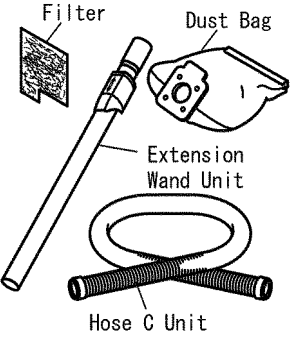
CONDITION	CHECKPOINT	FIGURE	CHECK METHOD	REMEDY
	ON/OFF SWITCH (in the P.C.B. Assy)		<ul style="list-style-type: none"> Check the continuity by pressing the On/Off Switch. 	<ul style="list-style-type: none"> If there is a problem, replace the P.C.B. Assy.
1. The Motor doesn't rotate. 2. The Power Control doesn't function.	TRIAC (on the P.C.B. Assy)		<ul style="list-style-type: none"> Check that the Triac has not been short-circuited. If there is continuity between T1 and T2, then there is a problem in the components. 	<ul style="list-style-type: none"> If there is a problem, replace the P.C.B. Assy.
	POWER CONTROL VOLUME (in the P.C.B. Assy)		<ul style="list-style-type: none"> The resistance between A and B must be switchable. 0~470Ω 	<ul style="list-style-type: none"> If there is a problem, replace the P.C.B. Assy.
The Cord cannot be pulled out.	CORD REEL UNIT MOTOR CASE UNIT		<ul style="list-style-type: none"> If the Cord cannot be pulled out, press the Brake Lever and confirm that the Cord can be rewound. Repeat operations to rewind and pull out the Cord two or three times and confirm that it can be normally rewound. 	<ul style="list-style-type: none"> If it is impossible to resolve the problem due to an abnormal condition of the Cord, separate the Body, untwist the Cord, and rewind it. Or, replace the Cord Reel Unit and rewind the Cord.
1. The Cord cannot be rewound. 2. The pulled out Cord cannot be locked.			Separate the Body and; <ul style="list-style-type: none"> Confirm that a sufficient number of spare turns have been made. Confirm that the Cord Reel Spring is working. Confirm that the Brake Lever Unit is working correctly to stop the Cord from rewinding. 	<ul style="list-style-type: none"> Make spare turns according to the engraved number of turns, or; Replace the Cord Reel Unit. Replace the Motor Case Unit.
1. The suction power is low. 2. The Motor stops during vacuuming. (The Thermo Protector in the Fan Motor Unit works.)	DUST BAG FILTER EXTENSION WAND UNIT HOSE C UNIT		Check for clogging with dust. <ul style="list-style-type: none"> Dust Bag Filter (in the Dust Box) Hose C Unit Extension Wand Unit 	Remove dust. <ul style="list-style-type: none"> Replace any broken Dust Bag, Filter, and/or Hose C Unit.

4 Disassembly and Assembly Instructions

Important: Always turn the vacuum cleaner is power off before replacing components.

Remove the power cord and plug from the mains.

*** Attention**

(1) When disassembling the vacuum cleaner, check the connections and wiring (pulling) of each component, and ensure that everything is restored correctly once repairs are complete.

(2) Handle all disassembled components and packing with care, and be sure to replace any components that may be accidentally damaged.

(3) Once repair operations are complete, always inspect the area around the repairs for any degradation, and ensure that all components that were removed for repair have been replaced in the correct wiring configurations. It is also necessary to test the operation of the vacuum cleaner and ensure that it is safe for subsequent use.

- Insulation resistance:

Must be at least $5M\Omega$ when a direct current of 500V is applied between the power plug terminals and the exterior of the motor.

- Dielectric strength:

Must be able to withstand 1250V of alternating current applied between the power plug terminals and the exterior of the motor for one minute.

(4) Do not make changes to models, components, or materials during repairs and services.

(5) If a wiring unit has been supplied as a spare part, the wiring unit must be simply replaced as it is, without any additional repairs or connections made to even part of the wiring.

(6) Insert/remove the fast-on terminals by pushing/pulling them straight out without jiggling them or applying unnecessary force.

4.1. Disassembly of the Dust Cover Assy

1. Open the Dust Cover Assy and insert a slotted screwdriver in the gap between the Dust Cover Assy and the Upper Body.

Move the slotted screwdriver in the direction of the arrow, and disassemble the Dust Cover Assy pulling upward.

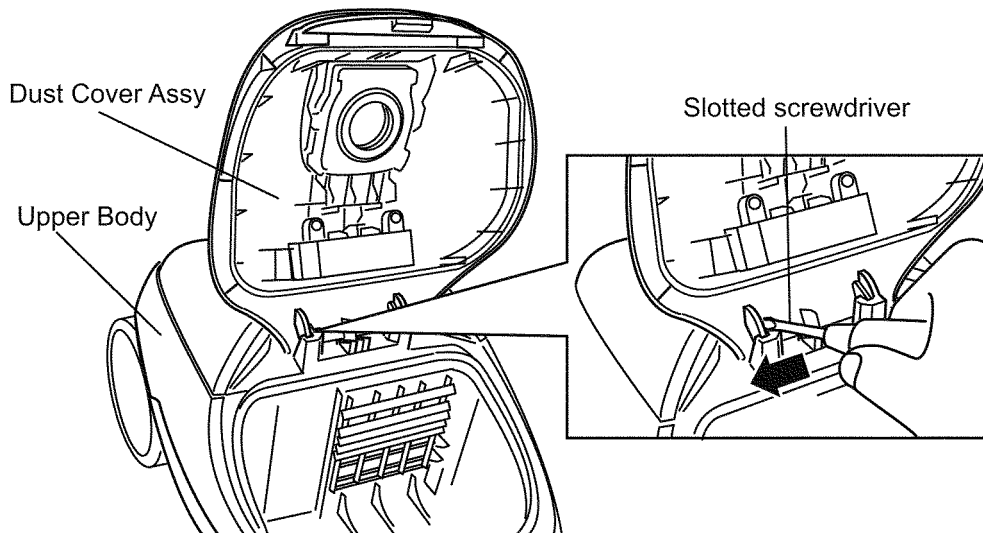

Fig.1

4.2. Disassembly of the Dust Bag Holder

1. Remove the Dust Bag Holder by inserting a slotted screwdriver into the mount of the Dust Bag Holder on the Lower Body Unit.

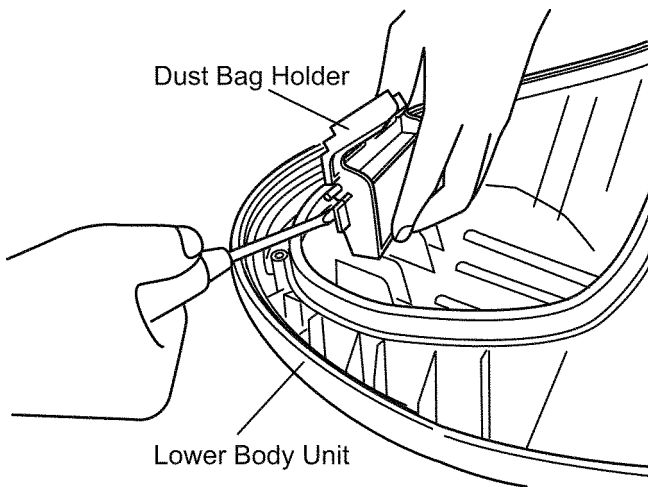

Fig.2

Caution (There is a Spring inside)

*** When replacing the Dust Bag Holder, disassemble and replace the Spring mounted inside.**

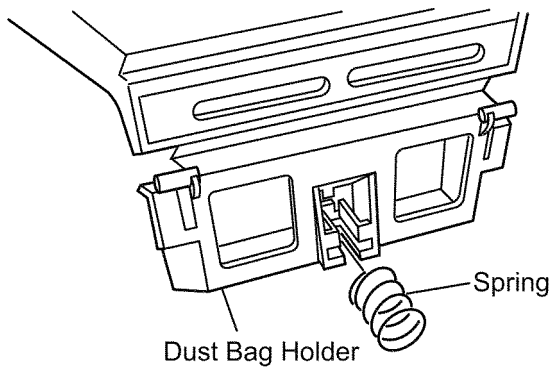

Fig.3

4.3. Disassembly of Body Cover Assy, Switch Pedal, Cord Rewind Button

1. Remove the Filter Case

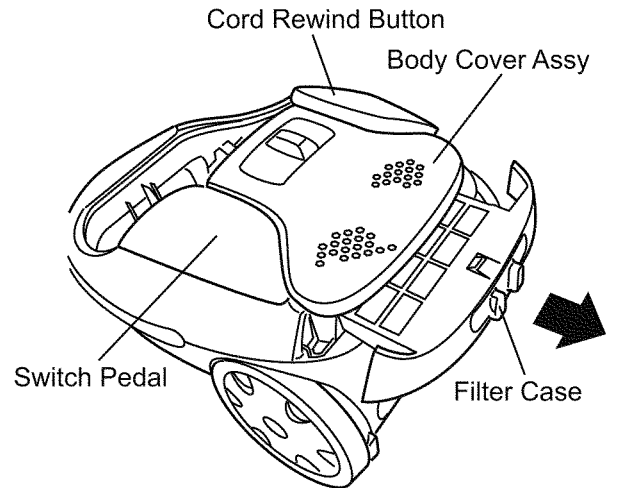

Fig.4

2. Remove 3 screws and disassemble the Body Cover Assy

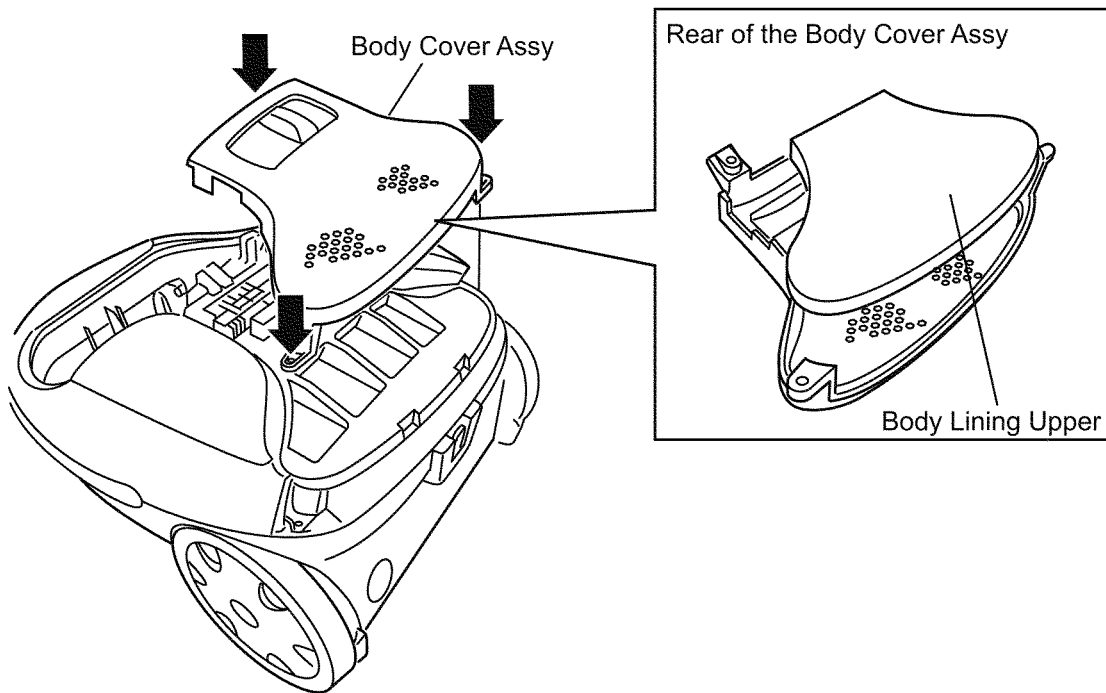

Fig.5

3. Disassemble the Switch Pedal/Cord Rewind Button toward the direction of the arrow
Caution: (Spring is placed inside.)
***Be careful not to lose the Spring.**

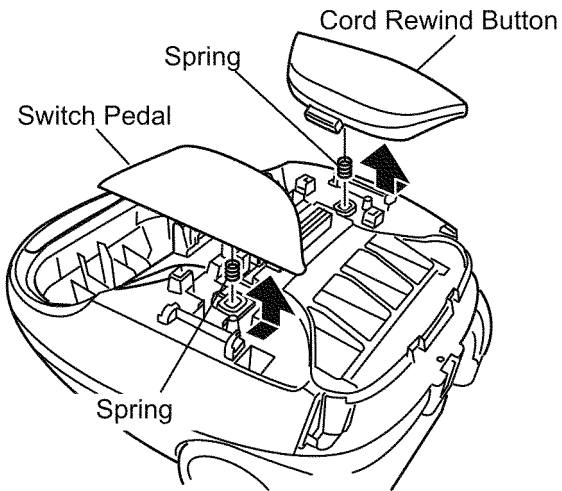

Fig.6

4.4. Disassembly of Upper Body, Handle Cover, and Guide Lever

1. Disassemble the Body Cover Assy and Switch Pedal as described in (4.3).

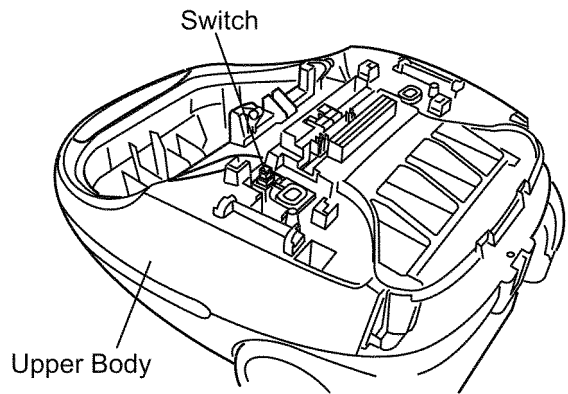

Fig.7

2. Remove the Switch (part of the P.C.B. Assy) from the Upper Body by pressing the tab in direction of the arrow.

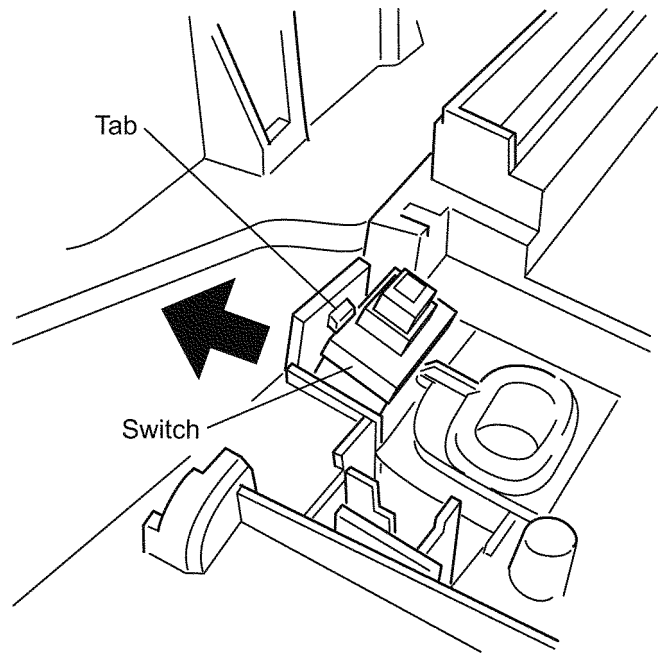

Fig.8

3. Slide the Switch, and push it inward at the position shown in the figure.

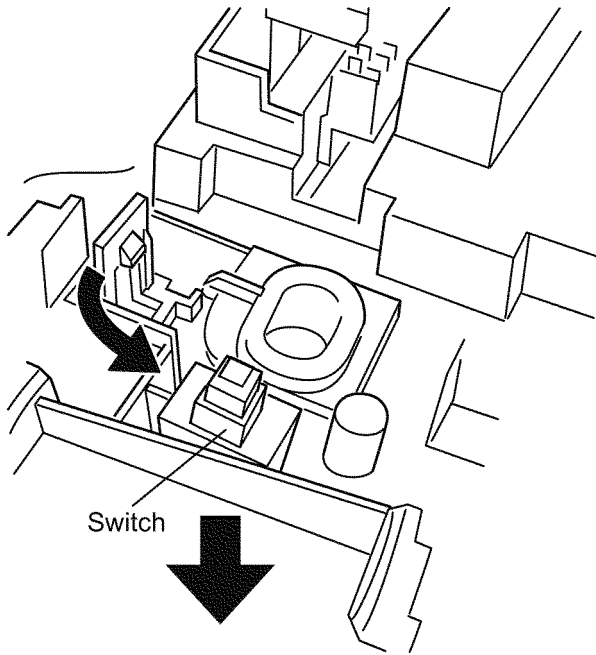

Fig.9

4. Remove 7 screws and disassemble the Upper Body slowly pulling it upwards.

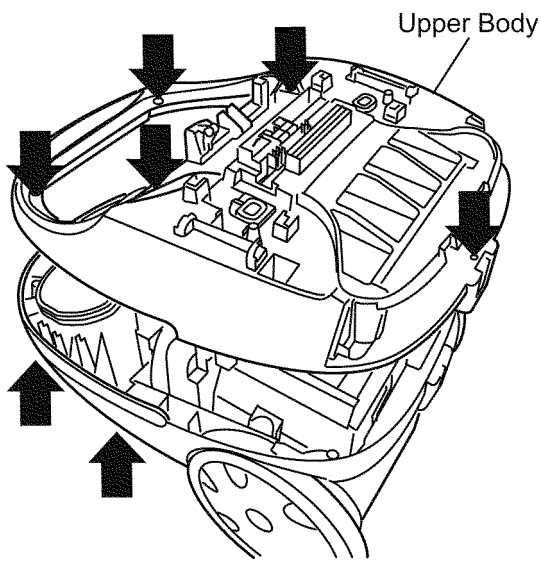

Fig.10

5. Disassembly of Handle Cover
Disassemble the Handle Cover from the Upper Body.

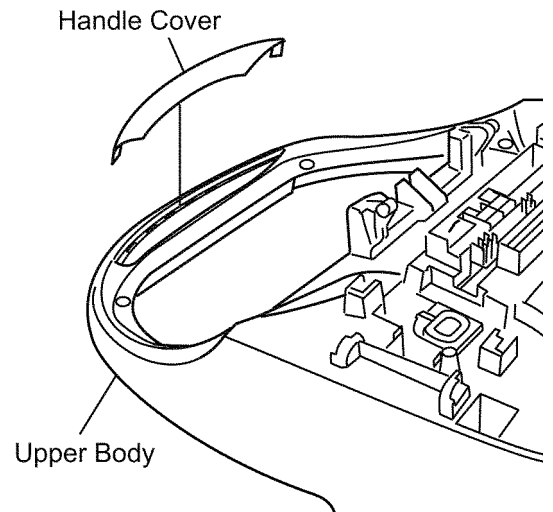

Fig.11

6. Disassembly of Guide Lever
Slide and disassemble the Guide Lever to the direction of the arrow.

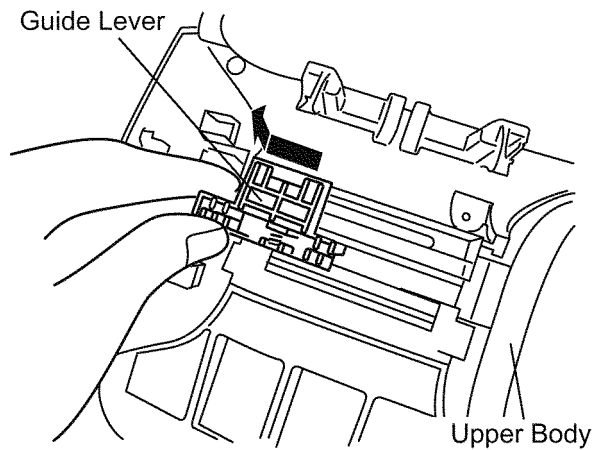

Fig.12

4.5. Disassembly of Motor Case Set

1. Disassemble the Rear Cover to the direction of the arrow, and disassemble the Motor Case Set pulling upward.

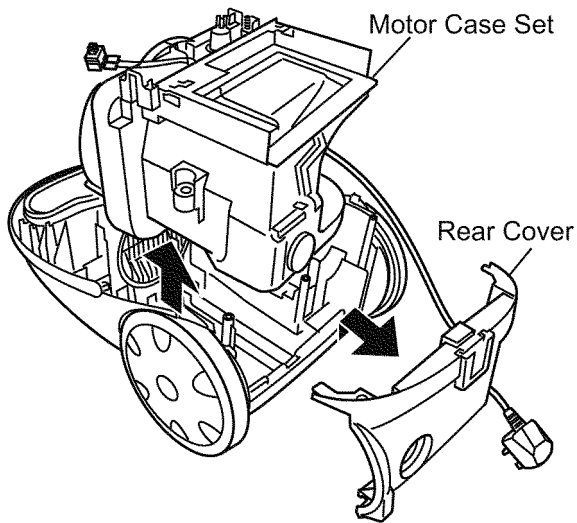

Fig.13

4.6. Disassembly of Cord Reel Unit

1. Release the pretension of the Cord Reel Unit slowly by holding on the Power Plug and pressing on the Brake Lever.

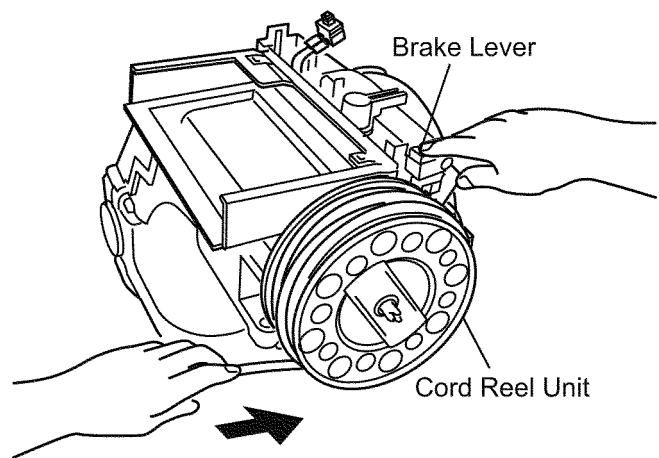

Fig.14

2. Remove the Cord Reel Unit from the Motor Case Set by inserting a slotted screwdriver into the shaft of the Cord Reel Unit and turning it 90 degrees counter-clockwise.

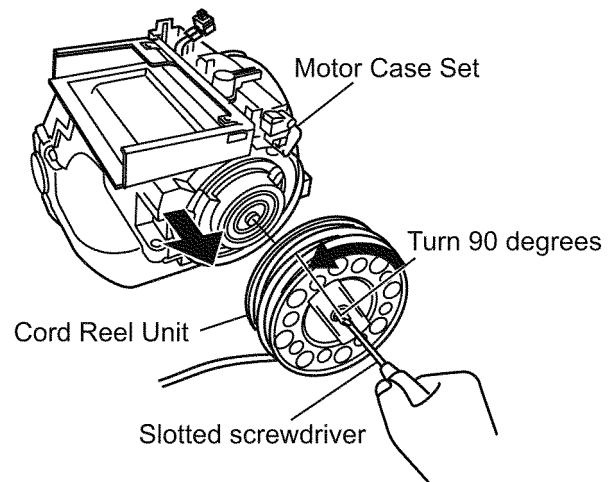

Fig.15

To assemble

- a. Assemble in reverse order of the disassembly
- b. Pretension the Cord Reel Unit
<How to pretension the Cord Reel Unit>
 - a. Turn the Cord Reel Unit holding on the Plug
 - b. Number of turns for pretension of the Cord is engraved on the steel plate at the side of the Cord Reel Unit

4.7. Disassembly of Rail Base Unit

1. Remove screw and disassemble the Rail Base Unit from the Motor Case Set.

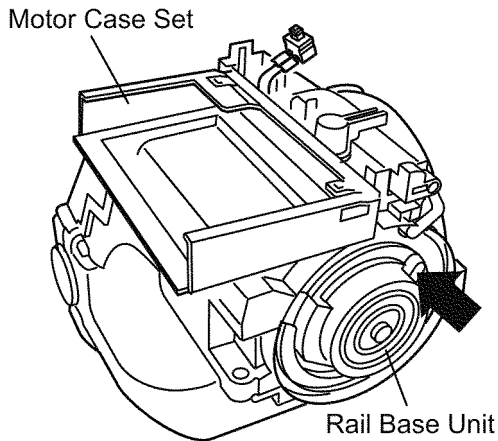

Fig.16

2. Remove the faston terminals on the Rail Base Unit.

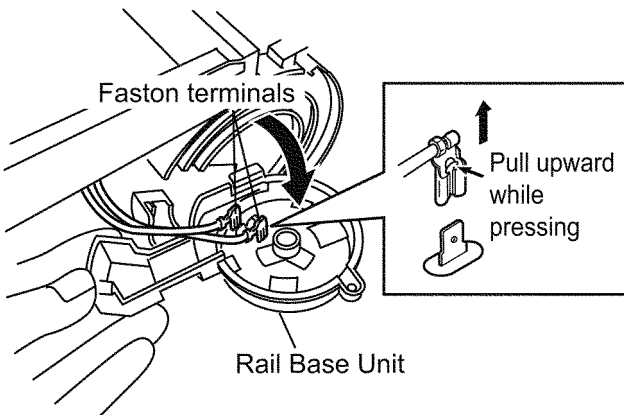

Fig.17

⚠ WARNING	
!	Pull the faston terminals straight out without twisting.

*** Apply the included furoyl when replacing the Rail Base Unit or the Cord Reel Unit. (Refer to the included instruction sheet for detail)**

4.8. Disassembly of Fan Motor Unit

1. Disassemble the Swivel Cap and remove 3 screws.

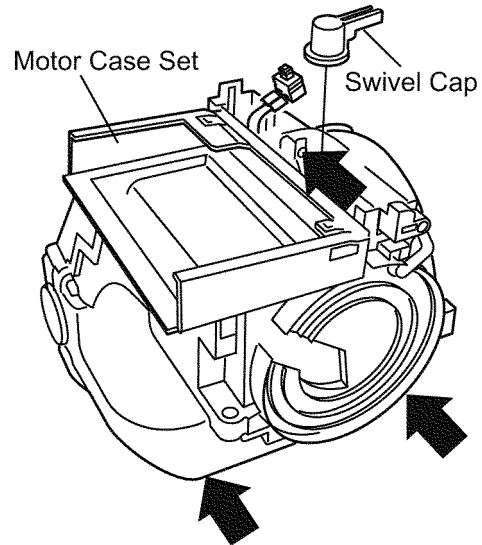

Fig.18

2. Remove the tabs (4 positions) of the Motor Case Unit and Motor Support Cover, and disassemble the Motor Case Unit and the Motor Support Cover.

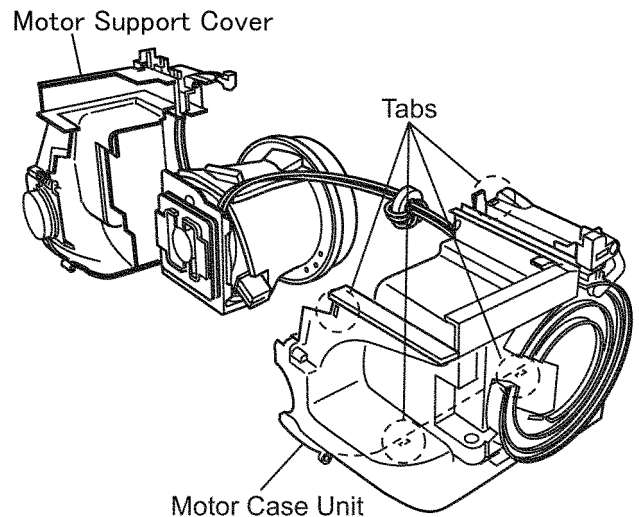

Fig.19

3. Disassemble the Noise Suppressor Unit
4. Disassemble the Motor Support Rubber (Rear)
5. Remove 2 screws and disassemble the Motor Support Front
6. Remove the Motor Support Front AU
7. Remove the faston terminals on the Lead Wire C Unit.

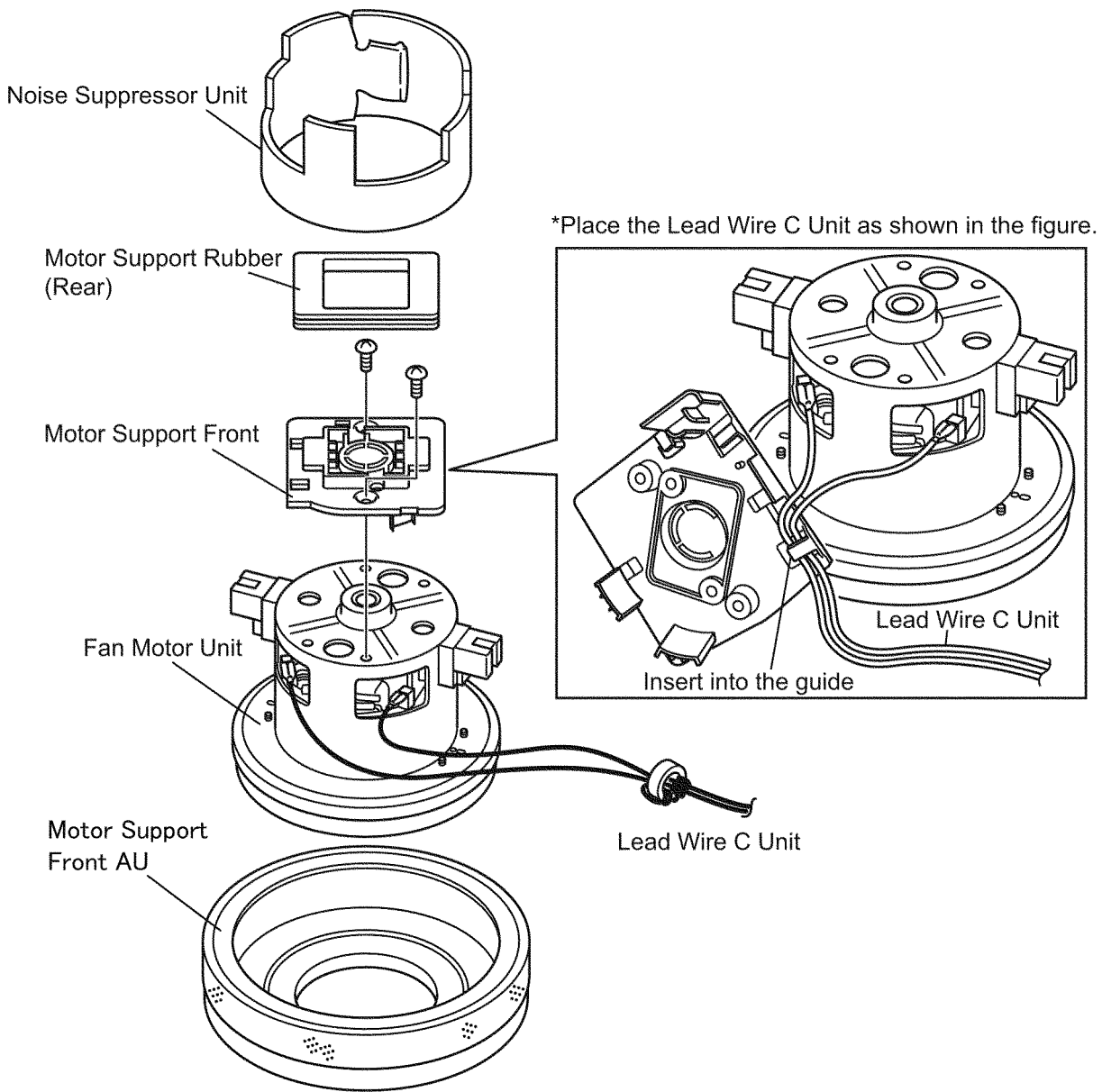

Fig.20

Wiring diagram for assembly

Place the ferrite core as shown in the figure, and assemble the Motor Case Unit taking care of the wiring of each wire.

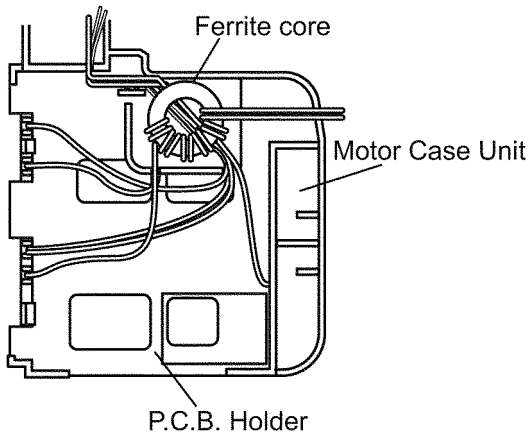

Fig.21

4.9. Disassembly of P.C.B. Assy

1. Disassembly of Volume (a part of P.C.B. Assy)

Disassemble the Volume by widening the tab of the Motor Case Unit using a slotted screwdriver.

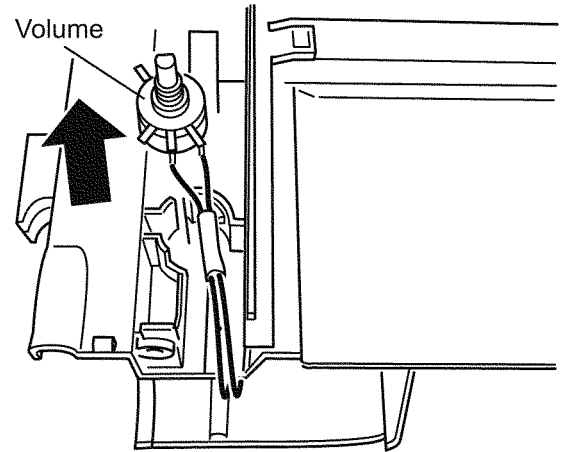
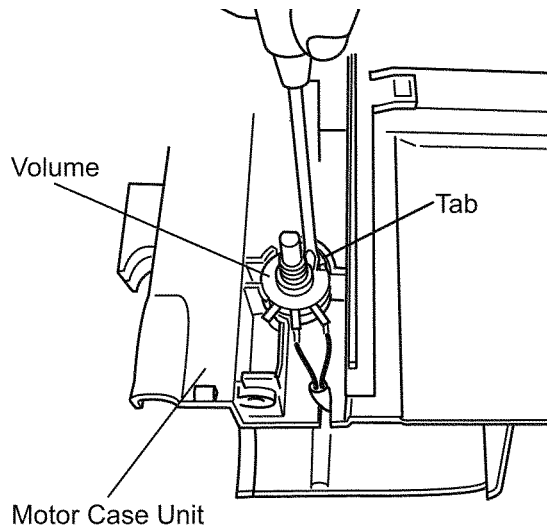

Fig.22

2. Disassemble the P.C.B. Holder by pressing on the tabs (2 positions) on the Motor Case Unit with your finger.

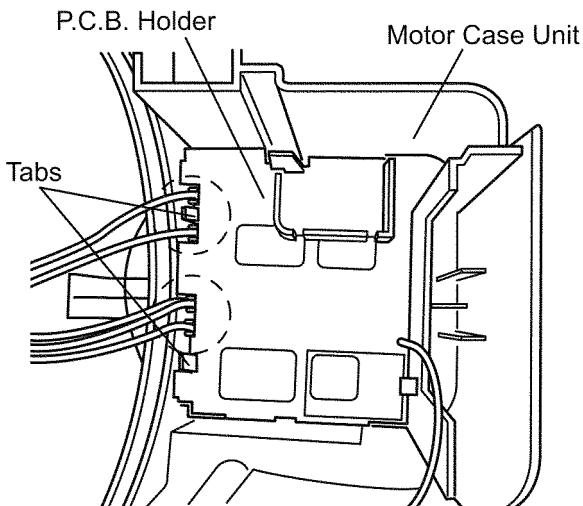

Fig.23

3. Remove the faston terminals and disassemble the P.C.B. Assy.

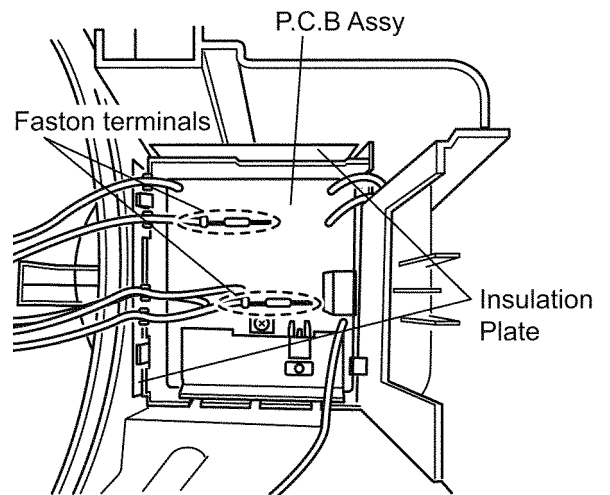

Fig.24

⚠ WARNING



Pull the faston terminals straight out without twisting.

4.10. Replacement of Blower Cover

1. Assemble the Spring (for Blower Cover) onto the Blower Cover

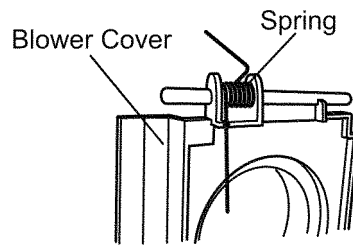

Fig.25

2. Assemble by inserting the shaft of the Blower Cover into the boss hole.

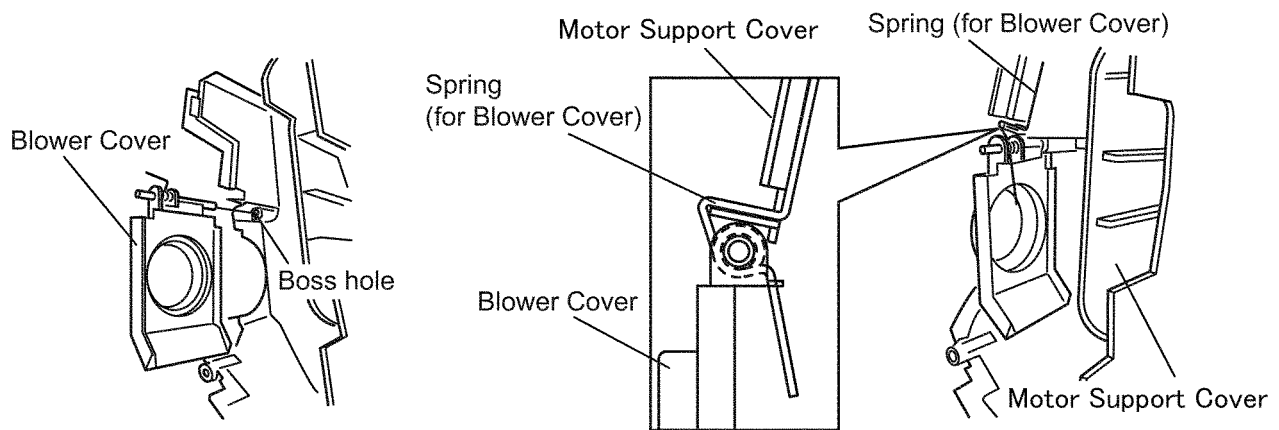

Fig.26

5 Wiring Connection Diagram

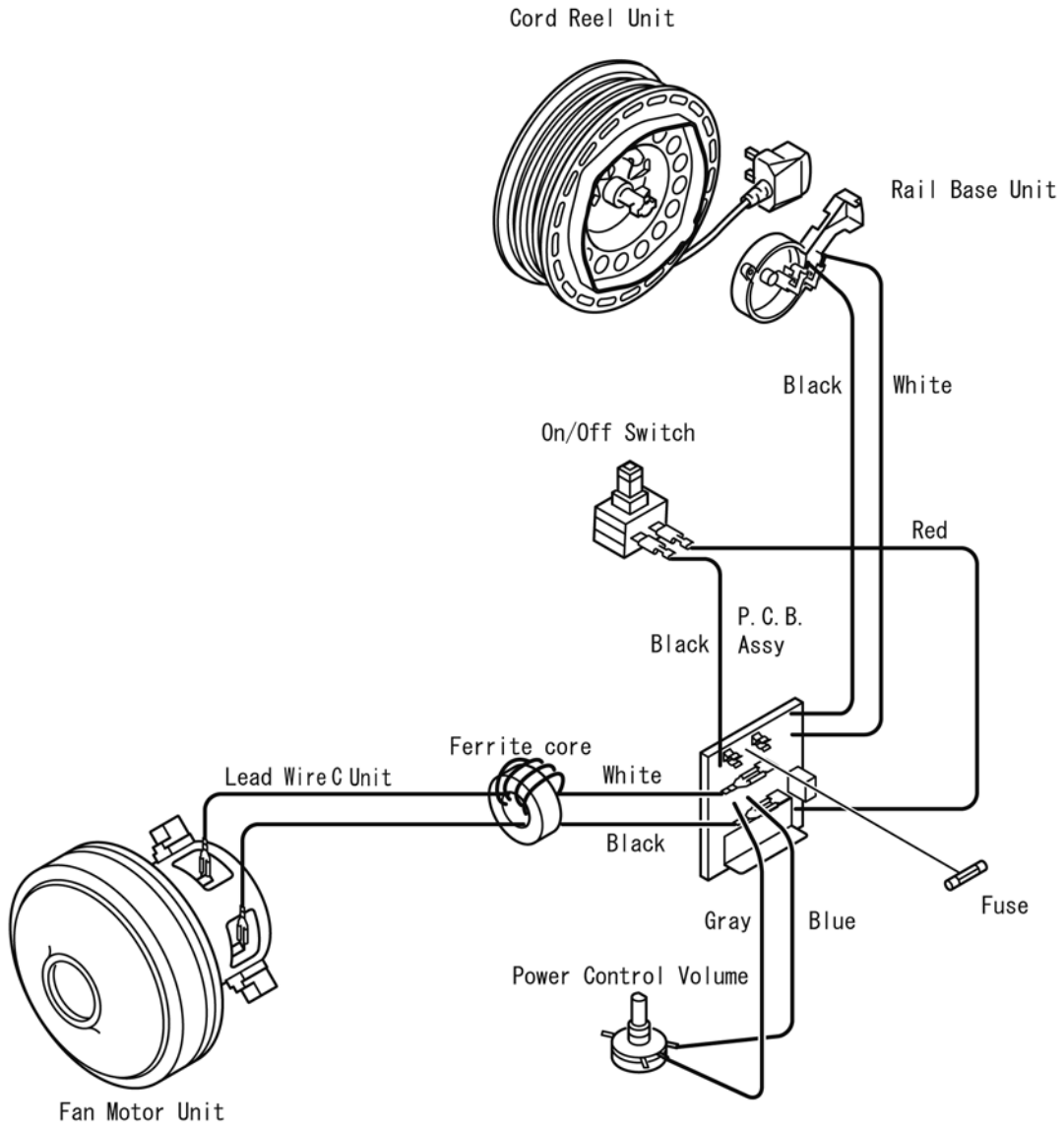
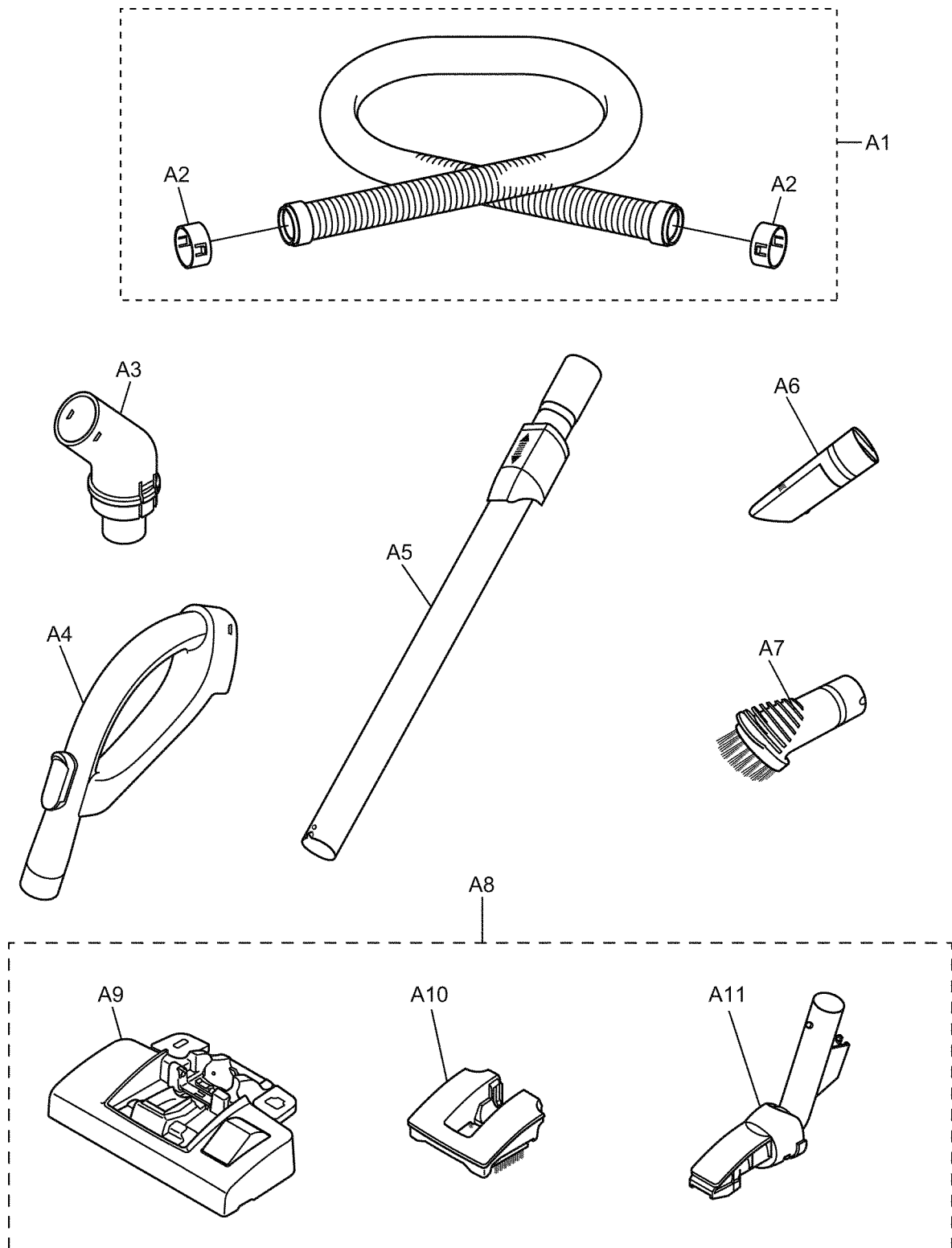

Fig.27

6 Exploded View and Replacement Parts List

6.1. EXPLODED VIEW (ATTACHMENTS)



6.2. PARTS LIST (ATTACHMENTS)

Safety	Ref. No.	Service Parts No.	Parts Name & Description	Q'ty	Remarks
	A1	AMV75PB60V0J	HOSE C UNIT	1	(HOSE)
	A2	AMC24P-0R0V	HOSE SUPPORTER	2	
	A3	AMV92PB80V0J	CONNECTION PIPE	1	
	A4	AMV98PB80V0J	CURVED WAND	1	(SUCTION REGULATOR)
	A5	AMV99P9U000J	EXTENSION WAND UNIT	1	(TELESCOPIC WAND)
	A6	AMC60RMV060J	CREVICE TOOL	1	(CREVICE NOZZLE)
	A7	AMV88RB6000J	DUSTING BRUSH UNIT	1	(DUSTING BRUSH)
	A8	AMV99RB80V0J	FLOOR NOZZLE ASSY	1	(FLOOR NOZZLE)
	A9	AMV96QB80V0J	FLOOR NOZZLE UNIT	1	
	A10	AMV88RB8000J	DUSTING BRUSH UNIT	1	(EZ UPHOLSTERY)
	A11	AMV97QB80V0J	CREVICE TOOL UNIT	1	(EZ CREVICE)

6.3. EXPLODED VIEW (BODY UNIT)

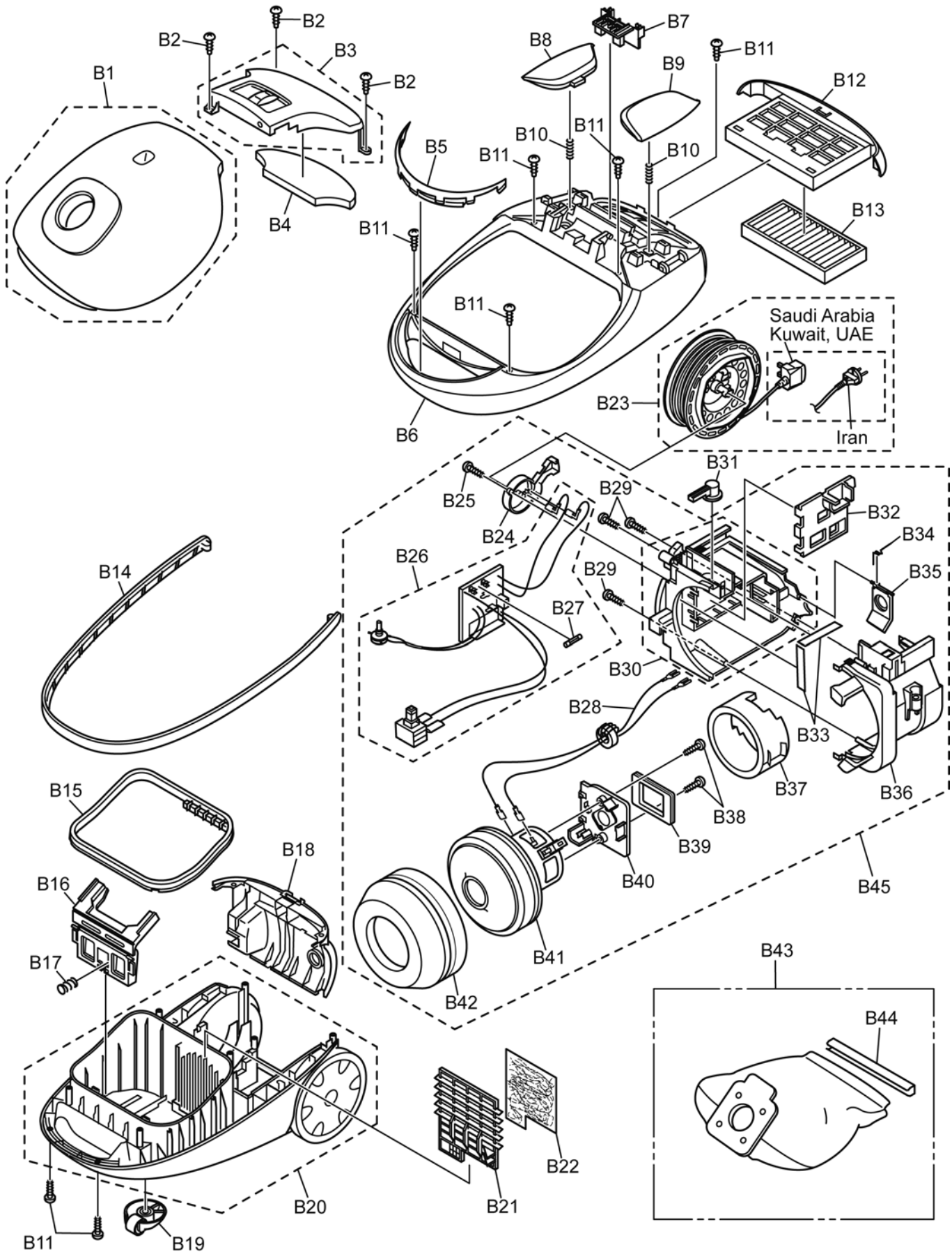

6.4. PARTS LIST (BODY UNIT)

Safety	Ref. No.	Service Parts No.	Parts Name & Description	Q'ty	Remarks
	B1	AMV93KB60R0J	DUST COVER ASSY	1	RED
	B1	AMV93KB60W0J	DUST COVER ASSY	1	WHITE
	B2	XTN4+20BFJ	SCREW	3	
	B3	AMV0YAB60R0J	BODY COVER ASSY	1	RED
	B3	AMV0YAB60W0J	BODY COVER ASSY	1	WHITE
	B4	AMV02GB6000J	BODY LINING UPPER	1	
	B5	AMV06BB8020J	HANDLE COVER	1	
	B6	AMV02AB80V0J	UPPER BODY	1	
	B7	AMV75NB80V0J	GUIDE LEVER	1	
	B8	AMV46NB80V0J	CORD REWIND BUTTON	1	(CORD REWIND PEDAL)
	B9	AMV05EB80V0J	SWITCH PEDAL	1	(ON/OFF SWITCH PEDAL)
	B10	AMC71N-4P0	SPRING	2	
	B11	XTN4+20BFJ	SCREW	7	
	B12	AMV42KB80V0J	FILTER CASE	1	
	B13	AMV85LB8000J	EXHAUST PACKING UNIT	1	(HEPA FILTER)
	B14	AMV31AB8020J	FURNITURE GUARD	1	
	B15	AMV73KB80V0J	DUST BOX PACKING	1	
	B16	AMV23KB8000J	DUST BAG HOLDER	1	
	B17	AMC34DYP000J	SPRING	1	
	B18	AMV01LB80V0J	REAR COVER	1	
	B19	AMC95C-0G0Z	CASTER UNIT	1	
	B20	AMV97AB60V0J	LOWER BODY UNIT	1	
	B21	AMC43KRH000J	PRE-FILTER	1	
	B22	AMC30K-RH0	FILTER	1	(PRE MOTOR FILTER)
△	B23	AMV99NB6008J	CORD REEL UNIT	1	SAUDI ARABIA , KUWAIT , UAE
△	B23	AMV99NB600EJ	CORD REEL UNIT	1	IRAN
△	B24	AMV98NB8000J	RAIL BASE UNIT	1	
	B25	XTN4+14BFJ	SCREW	1	
△	B26	AMV87GB6000J	P.C.B ASSY	1	
△	B27	AMV13WB8000J	FUSE	1	250V , 12A
△	B28	AMV69VB6000J	LEAD WIRE C UNIT	1	
	B29	XTN4+14BFJ	SCREW	3	
△	B30	AMV99FB6000J	MOTOR CASE UNIT	1	
	B31	AMV25QB8000J	SWIVEL CAP	1	
△	B32	AMV59VB8000J	P.C.B HOLDER	1	
△	B33	AMV23EB8000J	INSULATION PLATE	2	
	B34	AMC33L-UF0	SPRING(FOR BLOWER COVER)	1	
	B35	AMV29LB80V0J	BLOWER COVER	1	
△	B36	AMV63FB8000J	MOTOR SUPPORT COVER	1	
△	B37	AMV99GB6000J	NOISE SUPPRESSOR UNIT	1	
	B38	XTT4+10FFJ	SCREW	2	
	B39	AMC03FYD000J	MOTOR SUPPORT RUBBER(REAR)	1	
△	B40	AMV07FB8000J	MOTOR SUPPORT FRONT	1	
△	B41	AMV92FB600CJ	FAN MOTOR UNIT	1	
	B42	AMV0VFB7000J	MOTOR SUPPORT FRONT AU	1	
	B43	AMC99K-UF0	DUST BAG (CLOTH)	1	(CLOTH DUST BAG)
	B44	AMC23K-UG0	DUST BAG SUPPORTER	1	
	B45	AMV0PFB6000J	MOTOR CASE SET	1	
	-	AMV61ZB6000J	INDIVIDUAL CARTON	1	
	-	AMV69ZB8000J	CUSHION A	1	
	-	AMV70ZB8000J	CUSHION B	1	
	-	AMV0TZB8000J	CUSHION C	1	
	-	AMV01ZB6000J	INSTRUCTION BOOK	1	MC-CJ915/913/911
	-	AMV10ZB8000J	BODY BAG	1	
	-	AMV46ZB8000J	PARTITION BOARD	1	
	-	AMV72Z9U000J	CUSHION PLATE A	1	
	-	AMV56ZB8000J	CUSHION BOTTOM	1	SAUDI ARABIA , KUWAIT , UAE