

Service Manual

Vacuum Cleaner

Model No. **MC-CJ905-R747**
MC-CJ905-R349
MC-CJ905-R149
MC-CJ905-R147
MC-CJ905-K747
MC-CJ905-K349
MC-CJ905-K149
MC-CJ905-K147

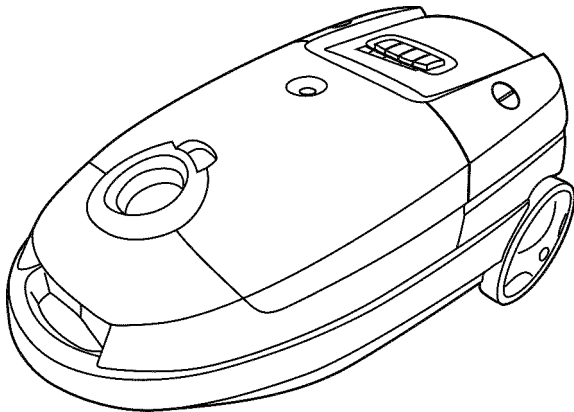

Product Color : (R) Red
 (K) Black

Destination : 1.Saudi Arabia, Kuwait --- MC-CJ905-R747
 --- MC-CJ905-K747
 2.Iran --- MC-CJ905-R149
 --- MC-CJ905-K149
 3.Egypt --- MC-CJ905-R349
 --- MC-CJ905-K349
 4.UAE --- MC-CJ905-R147
 --- MC-CJ905-K147

⚠ WARNING

This service information is designed for experienced repair technicians only and is not designed for use by the general public. It does not contain warnings or cautions to advise non-technical individuals of potential dangers in attempting to service a product. Products powered by electricity should be serviced or repaired only by experienced professional technicians. Any attempt to service or repair the product or products dealt with in this service information by anyone else could result in serious injury or death.

IMPORTANT SAFETY NOTICE

There are special components used in this equipment which are important for safety. These parts are marked by **⚠** in the Schematic Diagrams, Circuit Board Diagrams, Exploded Views and Replacement Parts List. It is essential that these critical parts should be replaced with manufacturer's specified parts to prevent shock, fire or other hazards. Do not modify the original design without permission of manufacturer.

Panasonic[®]

© Panasonic Corporation 2010 Unauthorized copying and distribution is a violation of law.

TABLE OF CONTENTS

	PAGE
1 Specifications -----	3
2 Location of Controls and Components -----	4
3 Troubleshooting Guide -----	5
4 Disassembly and Assembly Instructions -----	7
4.1. Removal of Dust Cover-----	7
4.2. Removal of Dust Bag Holder-----	8
4.3. Removal of Body Cover Unit, Cord Rewind Button, and Switch Pedal-----	8
4.4. Removal of Upper Body Unit and Power Control Switch-----	9
4.5. Removal of ON/OFF Switch (with Fuse and Capacitor)-----	10
4.6. Moter Assy(with motor support cover and motor case)-----	10
4.7. Removal of Motor Set-----	11
4.8. Removal of Thermo Protector-----	12
4.9. Removal of Cord Reel Partition Unit-----	12
4.10. Removal of Cord Reel Unit-----	12
5 Wiring Connection Diagram -----	13
6 Printed Circuit Board -----	14
7 Exploded View and Replacement Parts List -----	15
7.1. EXPLODED VIEW (ATTACHMENTS)-----	15
7.2. PARTS LIST (ATTACHMENTS)-----	15
7.3. EXPLODED VIEW (BODY UNIT)-----	16
7.4. PARTS LIST (BODY UNIT)-----	17

PAGE

1 Specifications

Model No.	MC-CJ905
Power source	220 V - 240 V ~ 50 /60 Hz
Max. input	2000 W
Nominal input	1350 - 1600 W
Dimensions (WxLxH)	315 mm x 557 mm x 252 mm
Net weight	7.0kg
Extension Wand	Telescopic
Crevice nozzle	1
Upholstery nozzle	1
Dusting brush	1

2 Location of Controls and Components

First, assemble the parts together.
(Hose, Extension wand, Floor nozzle)

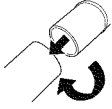

Parts are set surely so as not to come off.

2 Adjust the nozzle to suit the floor

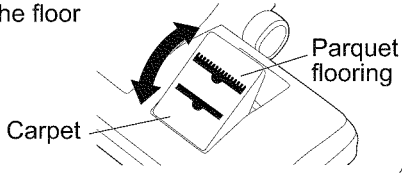

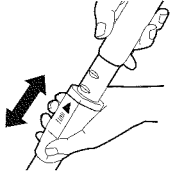

Telescopic wand
*MC-CJ905
Length may be adjusted.



Floor nozzle
*MC-CJ905

Alternative nozzles

-  Crevice nozzle:
For narrow gaps, etc.
-  Upholstery nozzle:
For cushions, covers, etc.
-  Dusting brush:
For furniture, venetian blinds, etc.

1 Start operation

Press .
Press the ① mark,
not the edge of the
pedal.

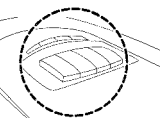

Changing the
cleaning power.

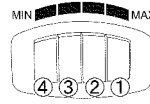

*MC-CJ905

- MAX ① High Position: For carpets etc.
② Standard Position: For hard floors
and walls etc.
③ Medium Position: For sofas and
chairs etc.
MIN ④ Low Position: For curtains etc.

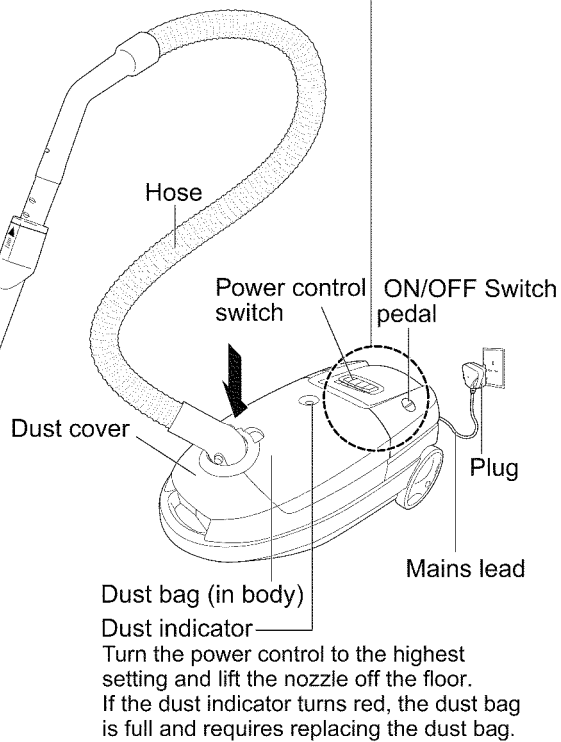

Cord rewind pedal

Press the  mark,
not the edge of
the pedal.

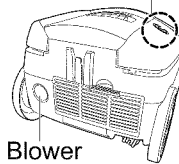

Blower

For locations where the nozzle will not enter, connect the hose to the blower and blow the dust out.

3 Troubleshooting Guide

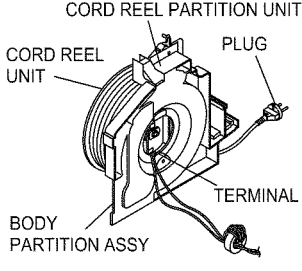
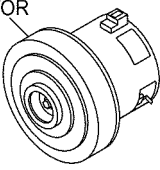
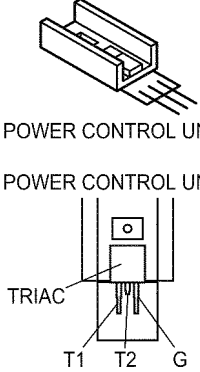
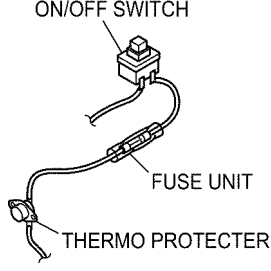
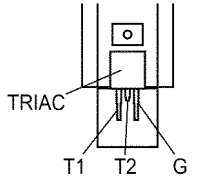
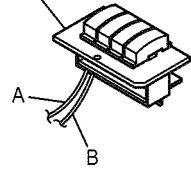
CONDITION	CHECKPOINT	FIGURE	CHECK METHOD	REMEDY
The motor doesn't rotate.	CORD REEL PARTITION UNIT	 <p>CORD REEL PARTITION UNIT</p> <p>CORD REEL UNIT</p> <p>PLUG</p> <p>TERMINAL</p> <p>BODY PARTITION ASSY</p>	<ul style="list-style-type: none"> • Check the continuity at both ends of the Plug and both ends of the Lead Wire Terminal of the Cord Reel Partition Unit. (Disconnection check) • Check the continuity of the Lead Wire connected to the Body Partition Assy. • There must be no problems between the Cord Reel Assy and the Body Partition Assy (e.g. burns in the contact, entry of dust). 	<ul style="list-style-type: none"> • If there is no continuity, replace the Cord Reel Assy, Body Partition Assy, or Cord Reel Partition Unit.
	MOTOR	 <p>MOTOR</p>	<ul style="list-style-type: none"> • Check the continuity between the terminals of the Motor. • Confirm that the Motor can be rotated by fingers without being locked. • Visually check for burns in the Motor (e.g. burns in the coil). 	<ul style="list-style-type: none"> • If there is a problem, replace the Motor Set. * Also check and replace the ON/OFF Switch (with the Fuse Unit).
	POWER CONTROL UNIT	 <p>POWER CONTROL UNIT</p> <p>POWER CONTROL UNIT</p> <p>TRIAC</p> <p>T1 T2 G</p>	<ul style="list-style-type: none"> • There must be no broken components. If they are normal: <ol style="list-style-type: none"> (1) T1-T2: There is not continuity. (2) T1-G: There is continuity. • There must be no broken foil of the Printed Circuit Board. • There must be no breaks in the Lead Wires. 	<ul style="list-style-type: none"> • If there is a problem, replace the Power Control Unit.
	FUSE UNIT	 <p>ON/OFF SWITCH</p> <p>FUSE UNIT</p> <p>THERMO PROTECTOR</p>	<ul style="list-style-type: none"> • Check if the Fuse has blown. Causes of fuse blowing: <ol style="list-style-type: none"> 1. Overcurrent 2. Burn of the Motor 3. Short-circuiting due to incorrect wiring • Continuity check. 	<ul style="list-style-type: none"> • Replace the ON/OFF Switch (with the Fuse Unit/Thermo Protector). *If a burn in the Motor caused the Fuse to blow, then also replace the Motor.
THERMO PROTECTOR ON/OFF SWITCH		<ul style="list-style-type: none"> • Check the continuity by pressing the ON/OFF Switch. 		
1. The Motor doesn't rotate. 2. The Power Control doesn't function.	POWER CONTROL UNIT	 <p>POWER CONTROL UNIT</p> <p>TRIAC</p> <p>T1 T2 G</p>	<ul style="list-style-type: none"> • Check that the Triac has not been short-circuited. If there is continuity between T1 and T2, then there is a problem in the components. 	<ul style="list-style-type: none"> • Replace the Power Control Unit.
	POWER CONTROL SWITCH	 <p>POWER CONTROL SWITCH</p> <p>A</p> <p>B</p>	<ul style="list-style-type: none"> • The resistance between A and B must be switchable. * See the circuit diagram (6. Printed Circuit Board) for the switch resistances. 	<ul style="list-style-type: none"> • Replace the Power Control Switch.

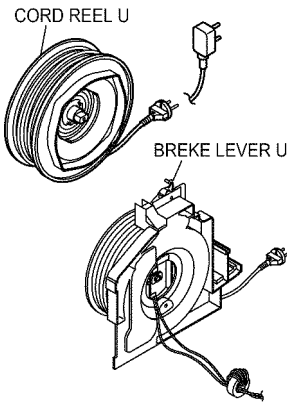
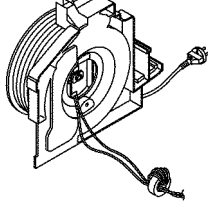
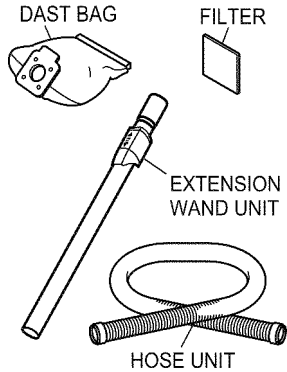
CONDITION	CHECKPOINT	FIGURE	CHECK METHOD	REMEDY
The Cord cannot be pulled out.	CORD REEL PARTITION UNIT	 <p>CORD REEL U BREKE LEVER U</p>	<ul style="list-style-type: none"> • If the Cord cannot be pulled out, press the Brake Lever and confirm that the Cord can be rewound. <p>Repeat operations to rewind and pull out the Cord two or three times and confirm that it can be normally rewound.</p>	<ul style="list-style-type: none"> • If it is impossible to resolve the problem due to an abnormal condition of the Cord, separate the Body, untwist the Cord, and rewind it. Or, replace the Cord Reel Unit and rewind the Cord.
1. The Cord cannot be rewound. 2. The pulled out Cord cannot be locked.			<p>Separate the Body and;</p> <ul style="list-style-type: none"> • Confirm that a sufficient number of spare turns have been made. • Confirm that the Cord Reel Spring is working. • Confirm that the Brake Lever Unit is working correctly to stop the Cord from rewinding. 	<ul style="list-style-type: none"> • Make spare turns according to the engraved number of turns, or; Replace the Cord Reel Unit. Replace the Cord Reel Partition Unit.
1. The suction power is low. 2. The Motor stops during vacuuming. (The Thermo Protector works.)	DAST BAG FILTER EXTENSION WAND UNIT HOSE	 <p>DAST BAG FILTER EXTENSION WAND UNIT HOSE UNIT</p>	<p>Check for clogging with dust.</p> <ul style="list-style-type: none"> • Dust Bag • Filter (in the Dust Box) • Hose • Extension Wand 	<p>Remove dust.</p> <ul style="list-style-type: none"> • Replace any broken Dust Bag, Filter, and/or Hose.

4 Disassembly and Assembly Instructions

Important: Always turn the vacuum cleaner's power off before replacing components.

Remove the power cord and plug from the mains.

* Attention

- (1) When disassembling the vacuum cleaner, check the connections and wiring (pulling) of each component, and ensure that everything is restored correctly once repairs are complete.
- (2) Handle all disassembled components and packing with care, and be sure to replace any components that may be accidentally damaged.
- (3) Once repair operations are complete, always inspect the area around the repairs for any degradation, and ensure that all components that were removed for repair have been replaced in the correct wiring configurations. It is also necessary to test the operation of the vacuum cleaner and ensure that it is safe for subsequent use.

- Insulation resistance:

Must be at least $5M\Omega$ when a direct current of 500V is applied between the power plug terminals and the exterior of the motor.

- Dielectric strength:

Must be able to withstand 1250V of alternating current applied between the power plug terminals and the exterior of the motor for one minute.

(4) Do not make changes to models, components, or materials during repairs and services.

(5) If a wiring unit has been supplied as a spare part, the wiring unit must be simply replaced as it is, without any additional repairs or connections made to even part of the wiring.

(6) Insert/remove the fast-on terminals by pushing/pulling them straight out without jiggling them or applying unnecessary force.

4.1. Removal of Dust Cover

1. Open Dust Cover Unit and insert a slotted screwdriver between the Dust Cover Unit and Upper Body Unit. Move the screwdriver in the direction of the arrow and remove the Dust Cover Unit by pulling it upward.

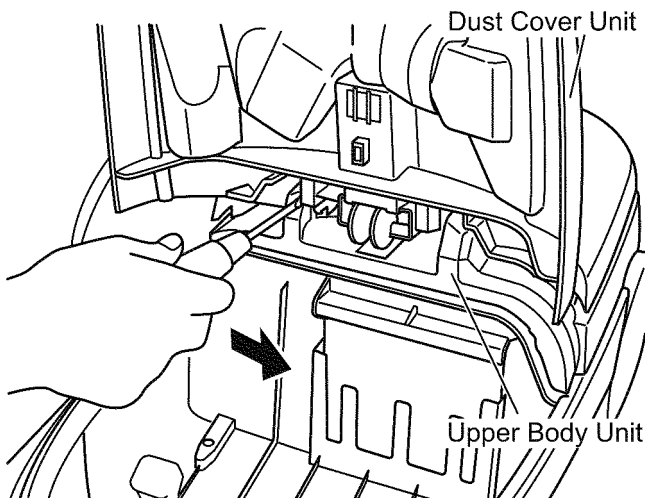

Fig.1

2. Disengage the four hooks of the Dust Box Plate.

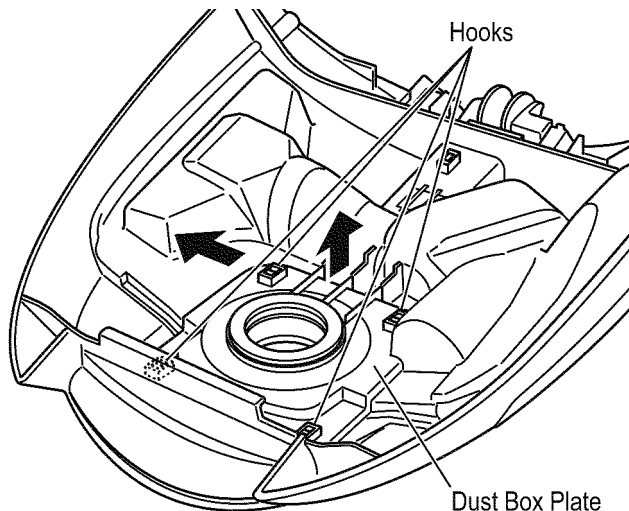

Fig.2

3. Remove the Dust Box Plate, Hose Fitting Rubber, and Suction Inlet from the Dust Cover.

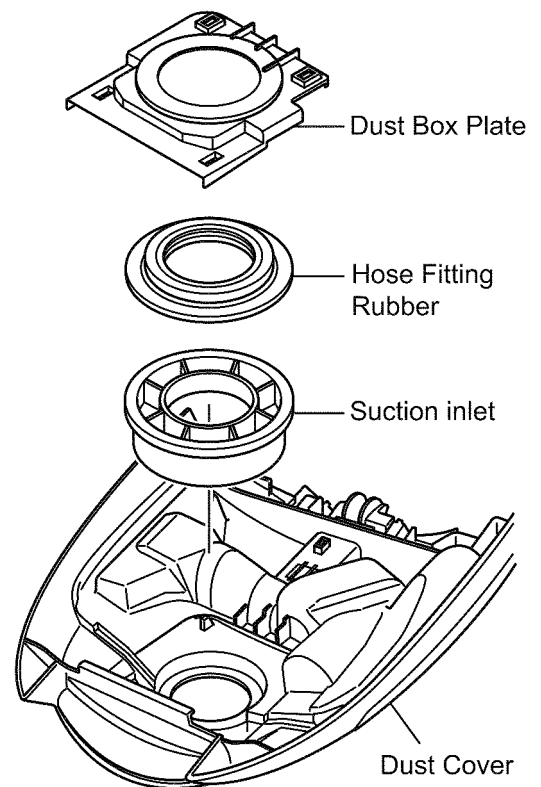

Fig.3

4.2. Removal of Dust Bag Holder

1. Insert a slotted screwdriver into the joint of the Dust Bag Holder in the Lower Body Unit and take out the Dust Bag Holder.

*** Be careful not to lose the Spring on the back of the Dust Bag Holder.**

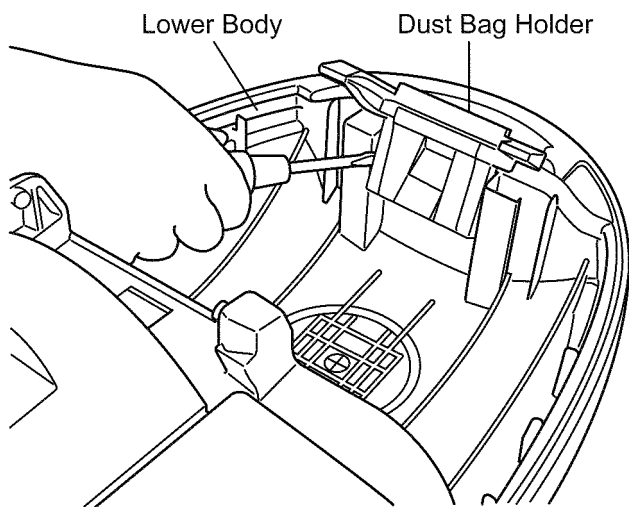

Fig.4

Assembling:

1. The assembly operation is the reverse of that of disassembly.
2. Check that the Dust Bag Holder works properly.

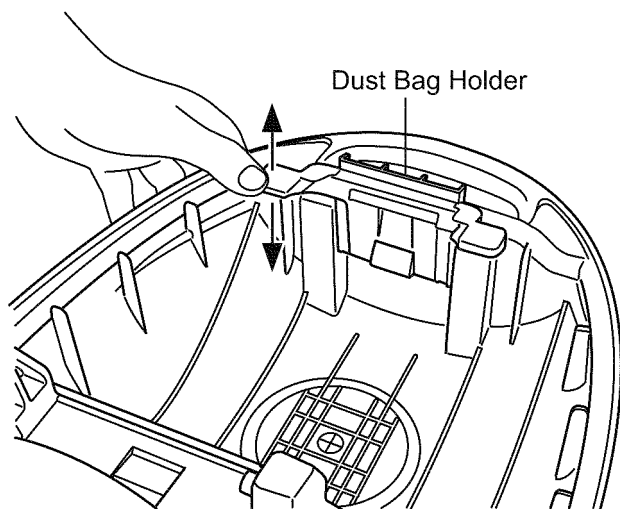
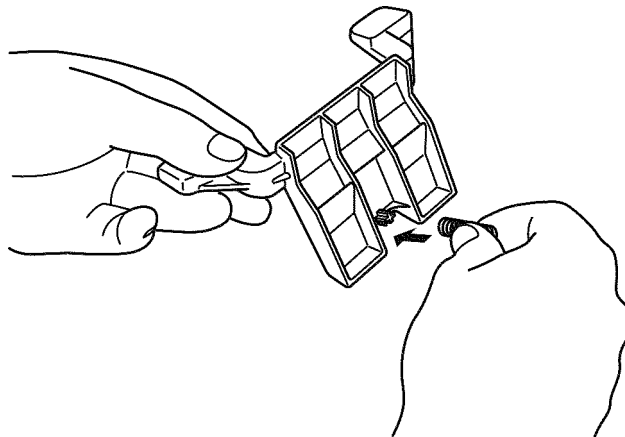

Fig.5

*** Don't forget to attach the Spring.**



4.3. Removal of Body Cover Unit, Cord Rewind Button, and Switch Pedal

1. Remove the screw of the Body Cover Unit.

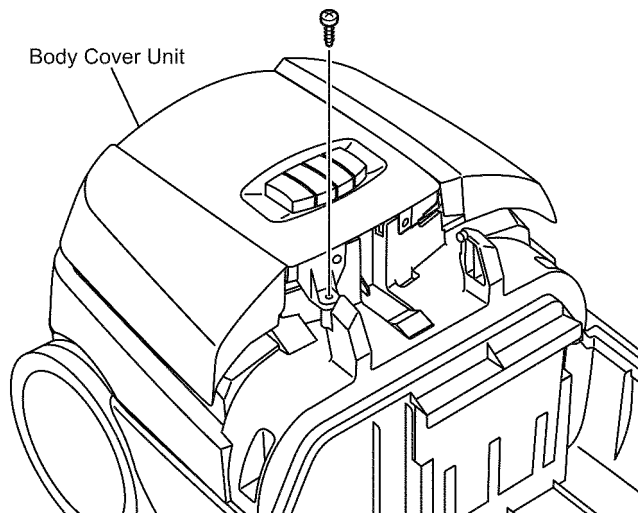

Fig.6

2. Remove the Body Cover Unit from the two projections of the Upper Body Unit using a slotted screwdriver as shown in the figure below.

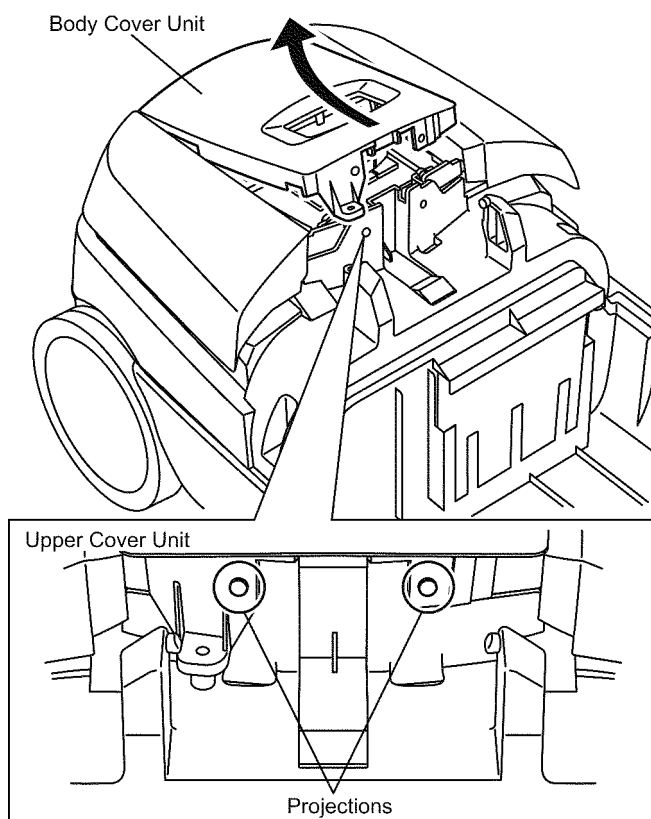

Fig.7

3. Remove the Cord Rewind Button and the ON/OFF Switch Button.

Caution: (Spring is placed inside.)
*** Be careful not to lose the Spring.**

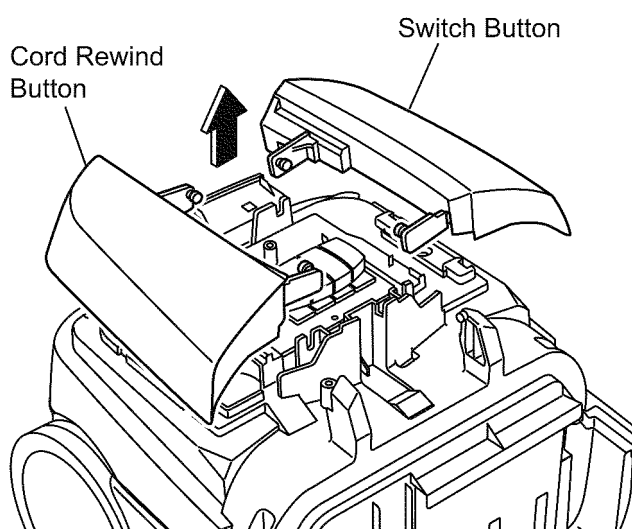

Fig.8

4.4. Removal of Upper Body Unit and Power Control Switch

1. Remove the four screws of the Upper Body Unit.
2. Slowly pull up and remove the Upper Body Unit.

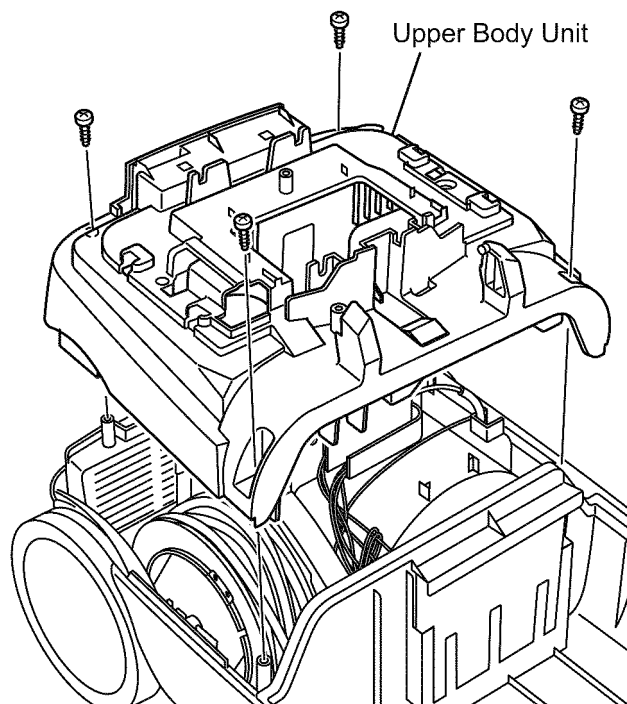

Fig.9

3. Remove the screw of the Power Control Switch and then remove the Power Control Switch.

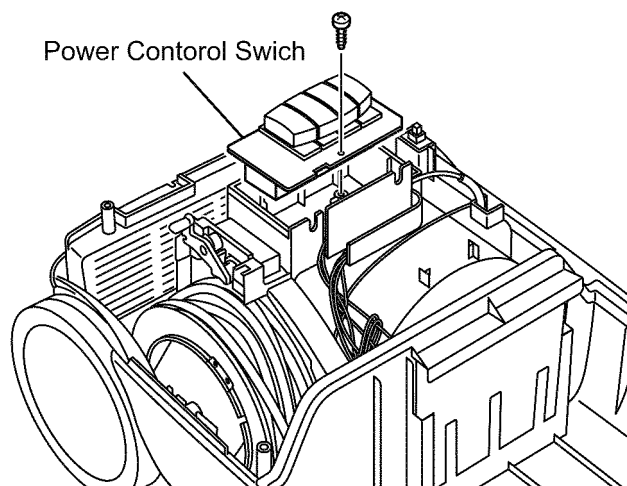

Fig.10

4.5. Removal of ON/OFF Switch (with Fuse and Capacitor)

1. Remove the Fuse Unit and the ON/OFF Switch from the Motor Support Cover Unit.

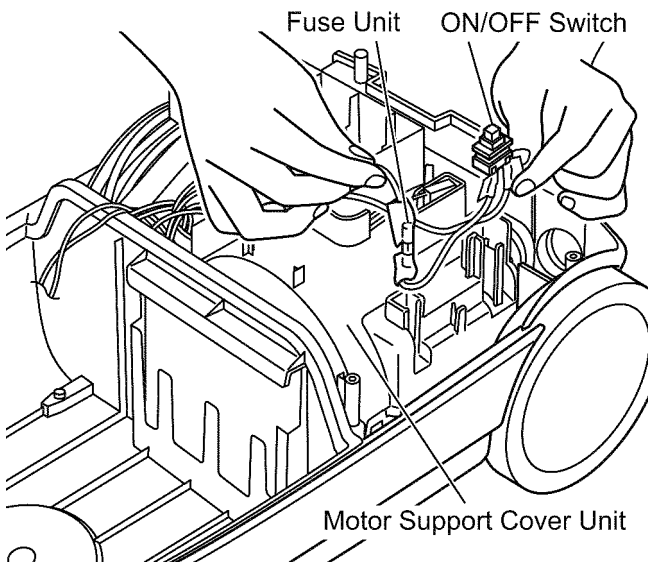

Fig.11

2. Remove the Capacitor.

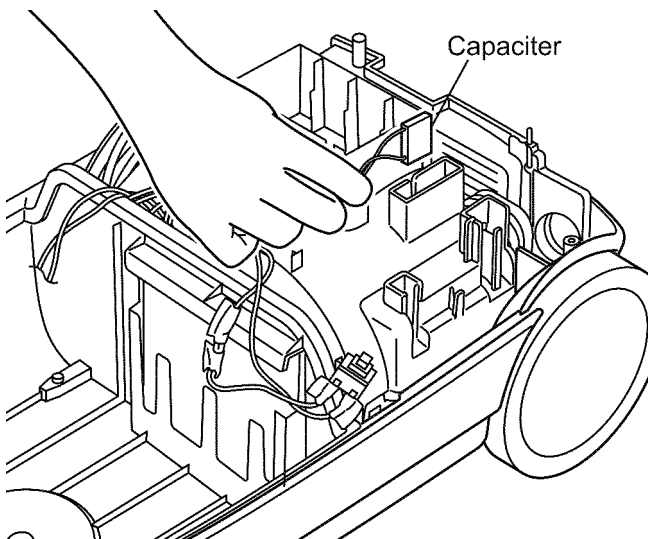

Fig.12

4.6. Motor Assy(with motor support cover and motor case)

1. Remove the Motor Assy from the Lower Body Unit.

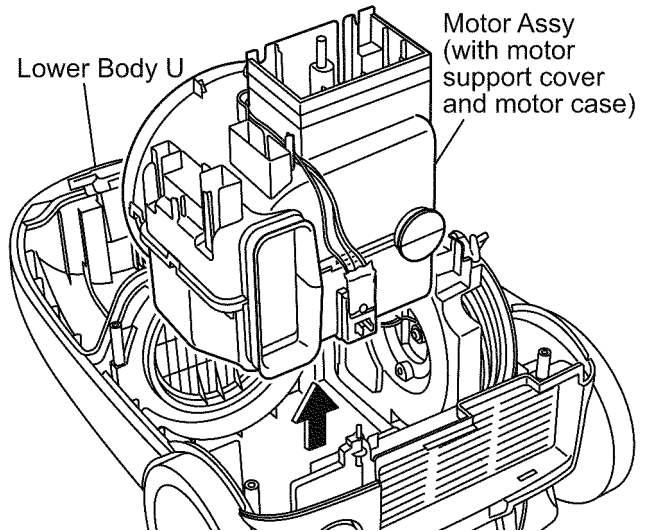

Fig.13

2. Pinch the stopper of the Motor Case Unit with needle-nose pliers as shown in the figure below and remove the Power Control Unit.

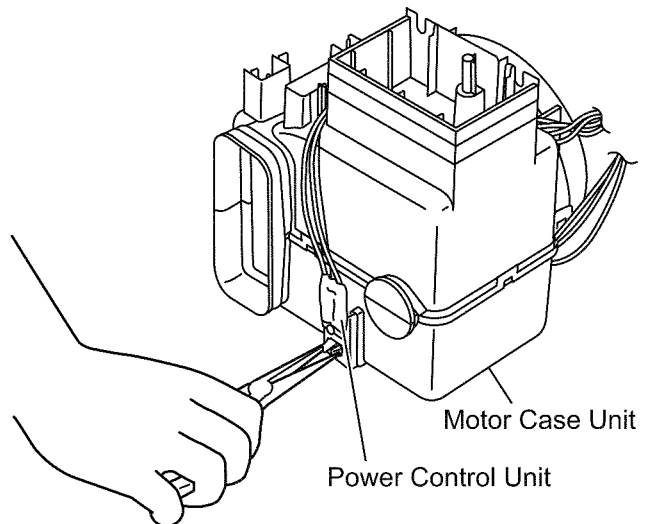

Fig.14

4.7. Removal of Motor Set

1. Remove the Motor Support Cover Unit.
2. Remove the Motor Set from the Motor Case Unit.

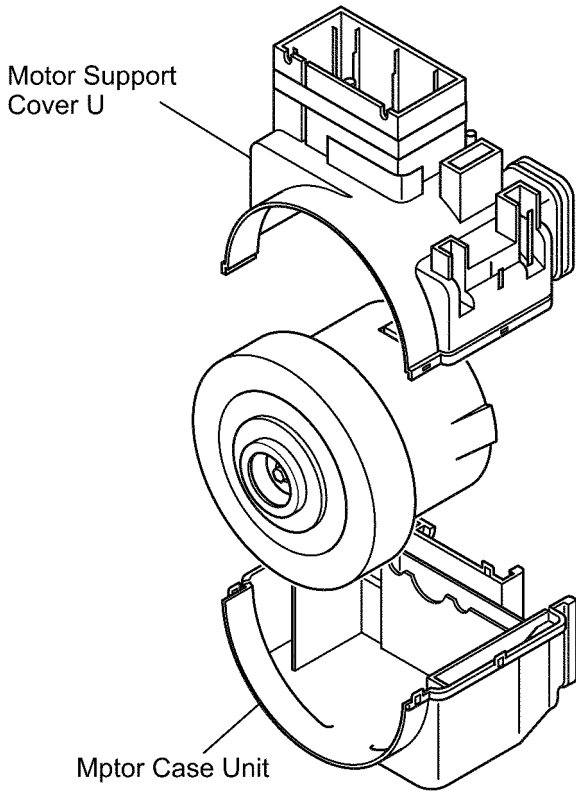

Fig.15

3. Remove the screws from the Motor Support Rubber and then remove the Motor Support Rubber (two pieces).
4. Remove the Noise Suppressor Unit.
5. Remove the Lead Wires.
6. Remove the Motor Support Rubber (Front).

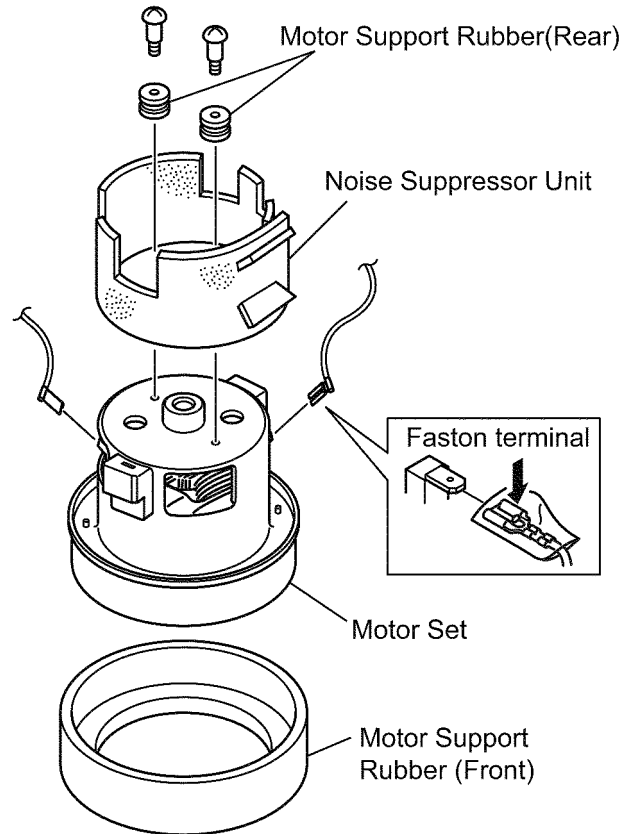
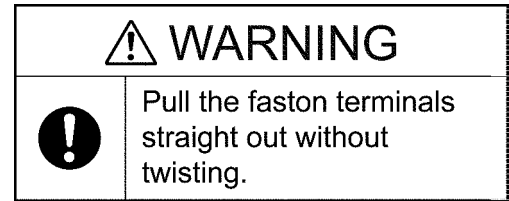

Fig.16

4.8. Removal of Thermo Protector

1. Remove the Thermo Protector.

* The Thermo Protector is supplied as an assembly with an ON/OFF Switch Unit (with Thermo Protector and Fuse).

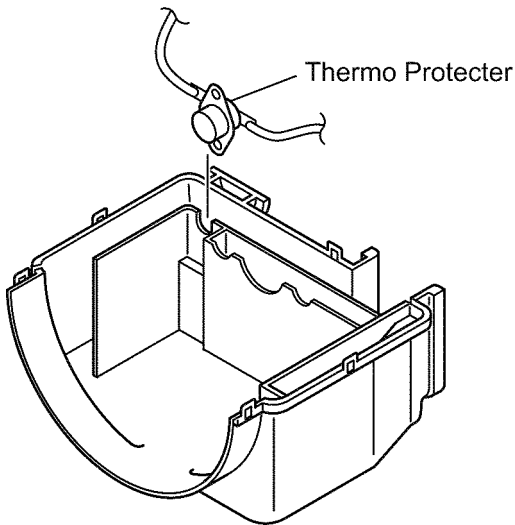

Fig.17

4.9. Removal of Cord Reel Partition Unit

1. Remove the Cord Reel Partition Unit from the Lower Body by holding its rear side and lifting it up in a backward direction.
2. Cut the Lead Wires at the base of the Wire Connector.

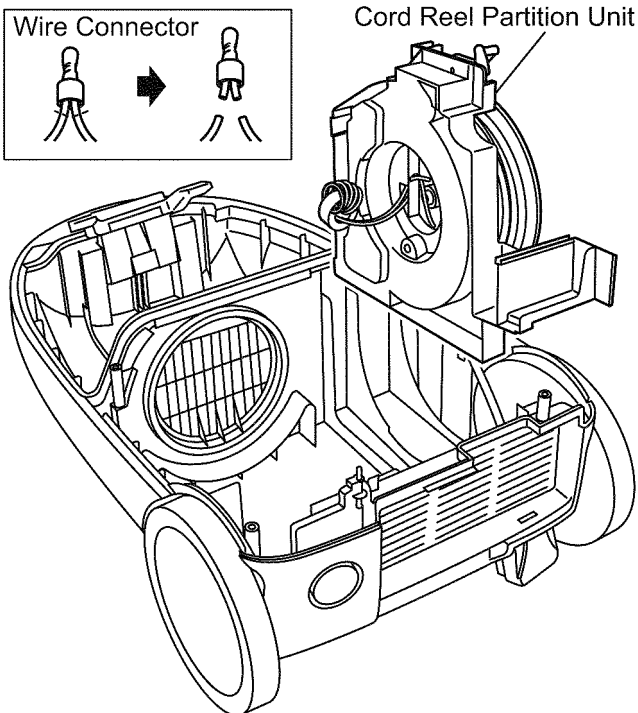
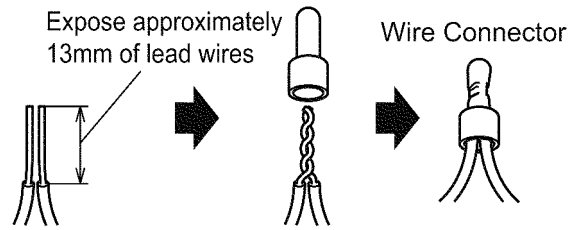

Fig.18

※ Use the dedicated tool to crimp the crimp contact.



Assembling:

When replacing the Cord Reel Partition Unit with a new one, connect it using Wire Connector CE-230 and wrap Gasket V (Glass Tape) around it.

4.10. Removal of Cord Reel Unit

1. Press the Brake Lever Unit of the Cord Reel Partition Unit to unwind spare turns.

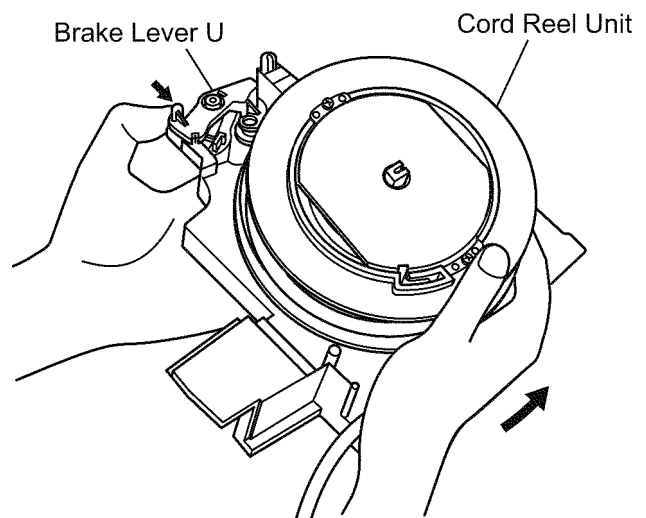

Fig.20

2. Remove the center screw and remove the Cord Reel Unit.

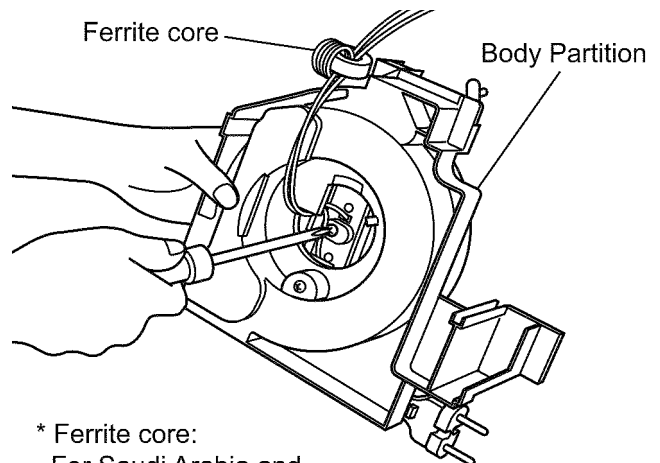

Fig.21

* Ferrite core:
For Saudi Arabia and Kuwait only. Not for UAE or Iran or Egypt.

Assembling:

* When replacing the Cord Reel Unit with a new one, place it in the Body Partition in the reverse order of disassembly by screwing it.

5 Wiring Connection Diagram

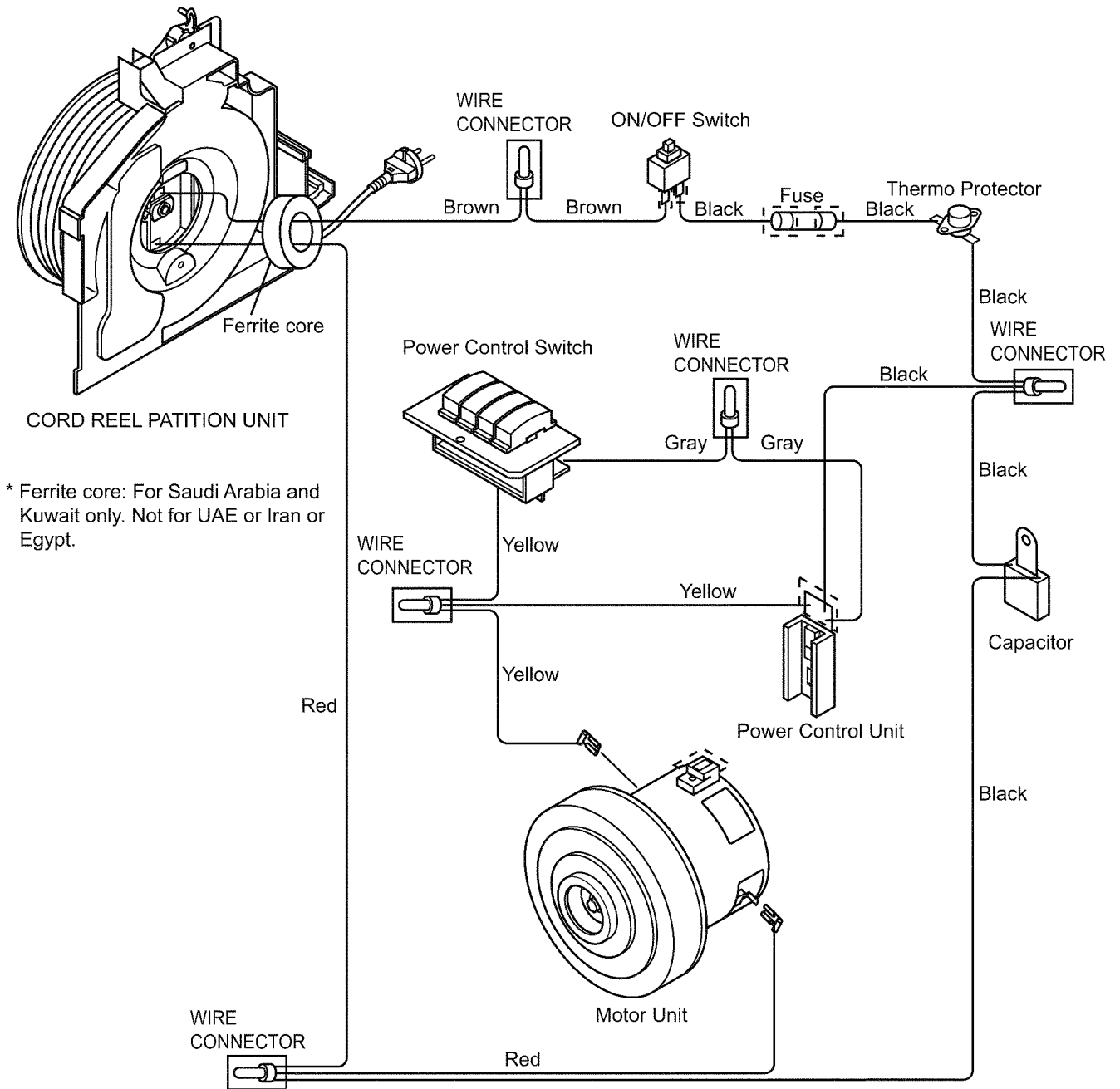

* When using the Wire Connector (CE-230) for connection purposes, be sure to wrap Gasket V (Glass Tape) around it. After removing the Tape from the other parts, also be sure to wrap the Tape around them.

 Attach Gasket V (AMC56L18000J) when repairing.

 Gasket V included with the Parts Unit

6 Printed Circuit Board

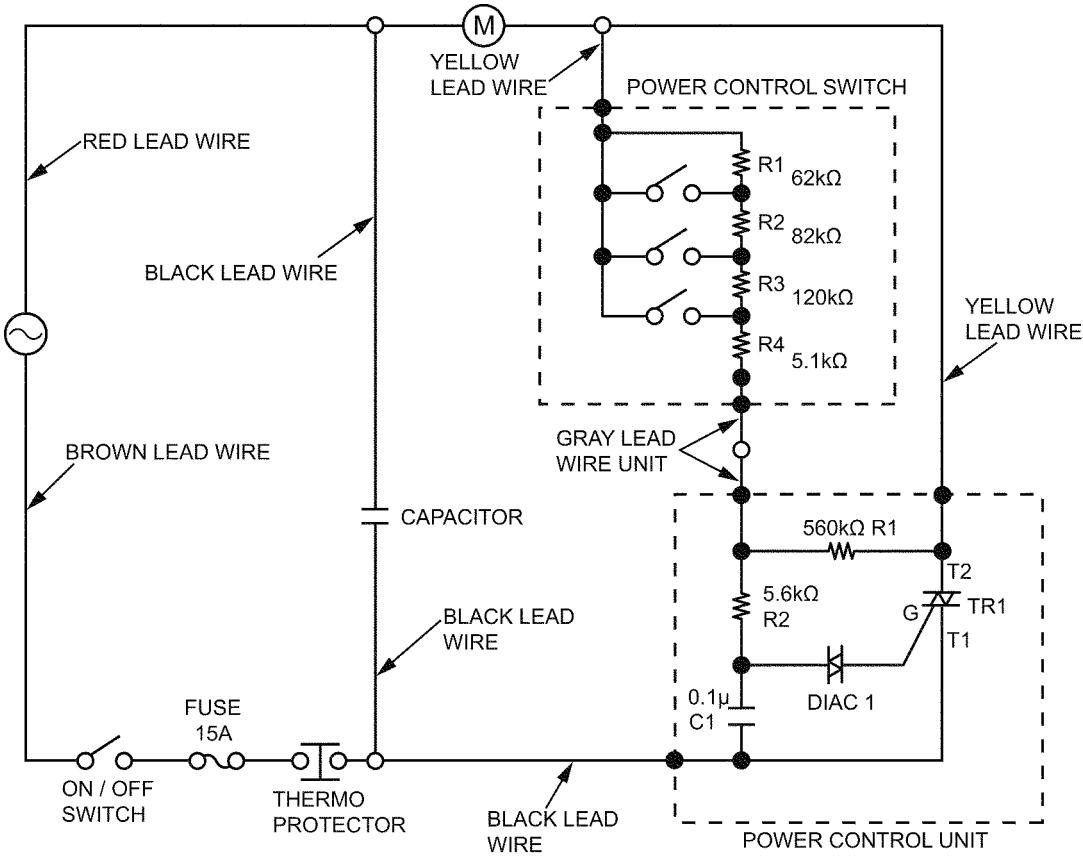

Resistances of the Power Control Switch



A	5.1kΩ	±5%
B	125.1kΩ	±5%
C	207.1kΩ	±5%
D	269.1kΩ	±5%

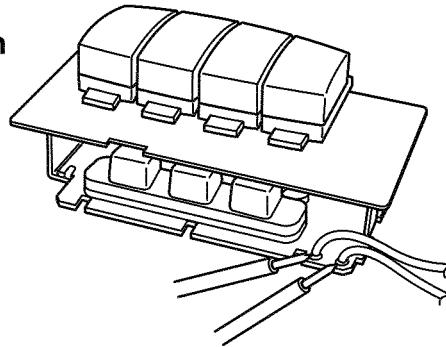

• Power Control Switch check

* Press switches A through D and measure the resistance between the Lead Wires of the switch.

7 Exploded View and Replacement Parts List

7.1. EXPLODED VIEW (ATTACHMENTS)

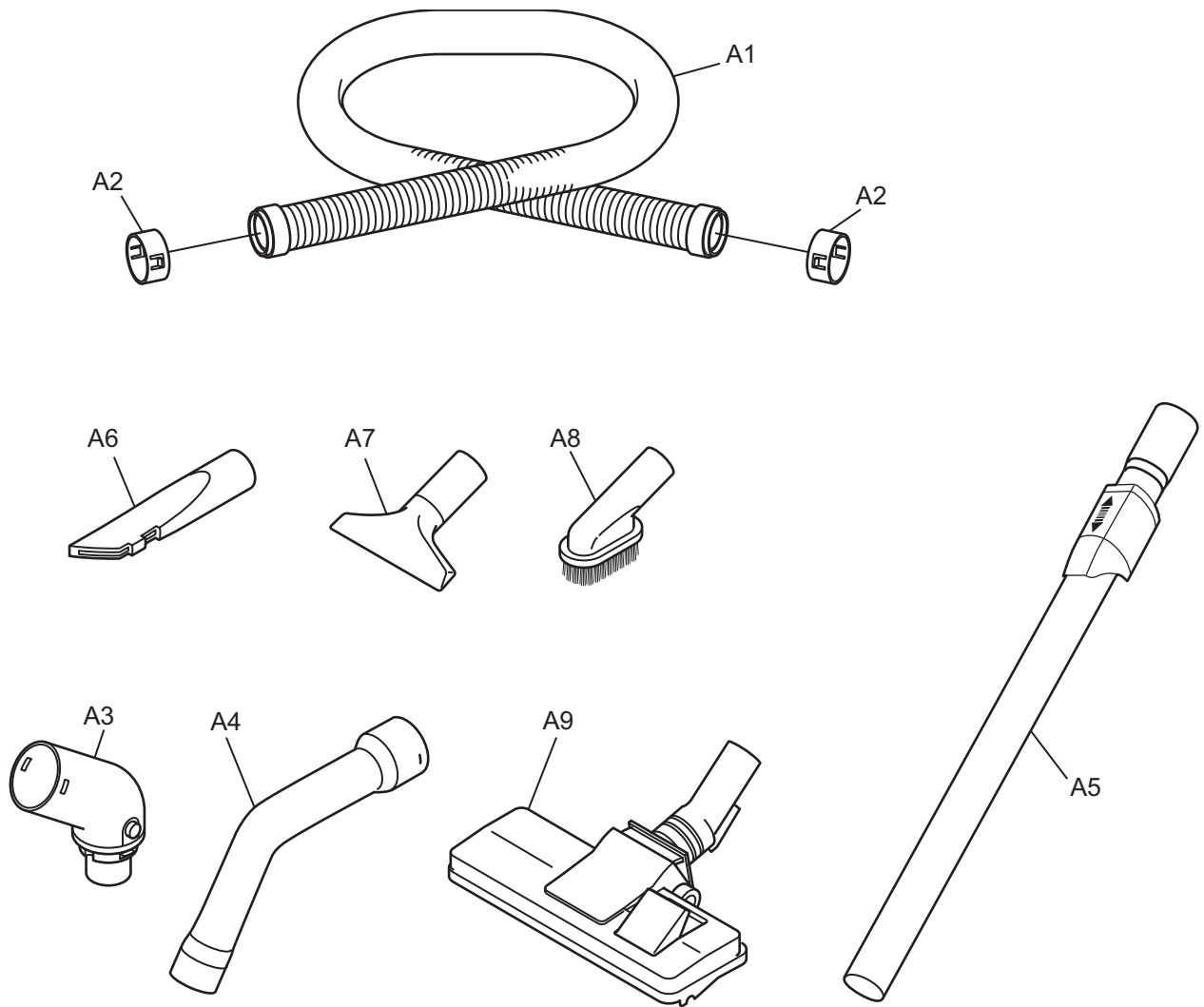

7.2. PARTS LIST (ATTACHMENTS)

Safety	Ref.No	Service Parts No.	Part Name & Description	Q'TY	Remarks
	A1	AMV84P9U0S0J	HOSE UNIT	1	(HOSE)
	A2	AMC24P-0R0V	HOSE SUPPORTER	2	
	A3	AMC92P-GA0V	CONNECTION PIPE	1	
	A4	AMC98P-GA0V	CURVED PIPE UNIT	1	
	A5	AMC99P-HP0	EXTENSION WAND UNIT	1	(TELESCOPIC WAND)
	A6	AMC60R-DB03	CREVICE TOOL	1	(CREVICE NOZZLE)
	A7	AMC86R-860V	UPHOLSTERY BRUSH	1	(UPHOLSTERY NOZZLE)
	A8	AMC88R-7K0V	DUSTING BRUSH	1	
	A9	AMC99R-GA0U	FLOOR NOZZLE ASSY	1	(FLOOR NOZZLE)

7.3. EXPLODED VIEW (BODY UNIT)

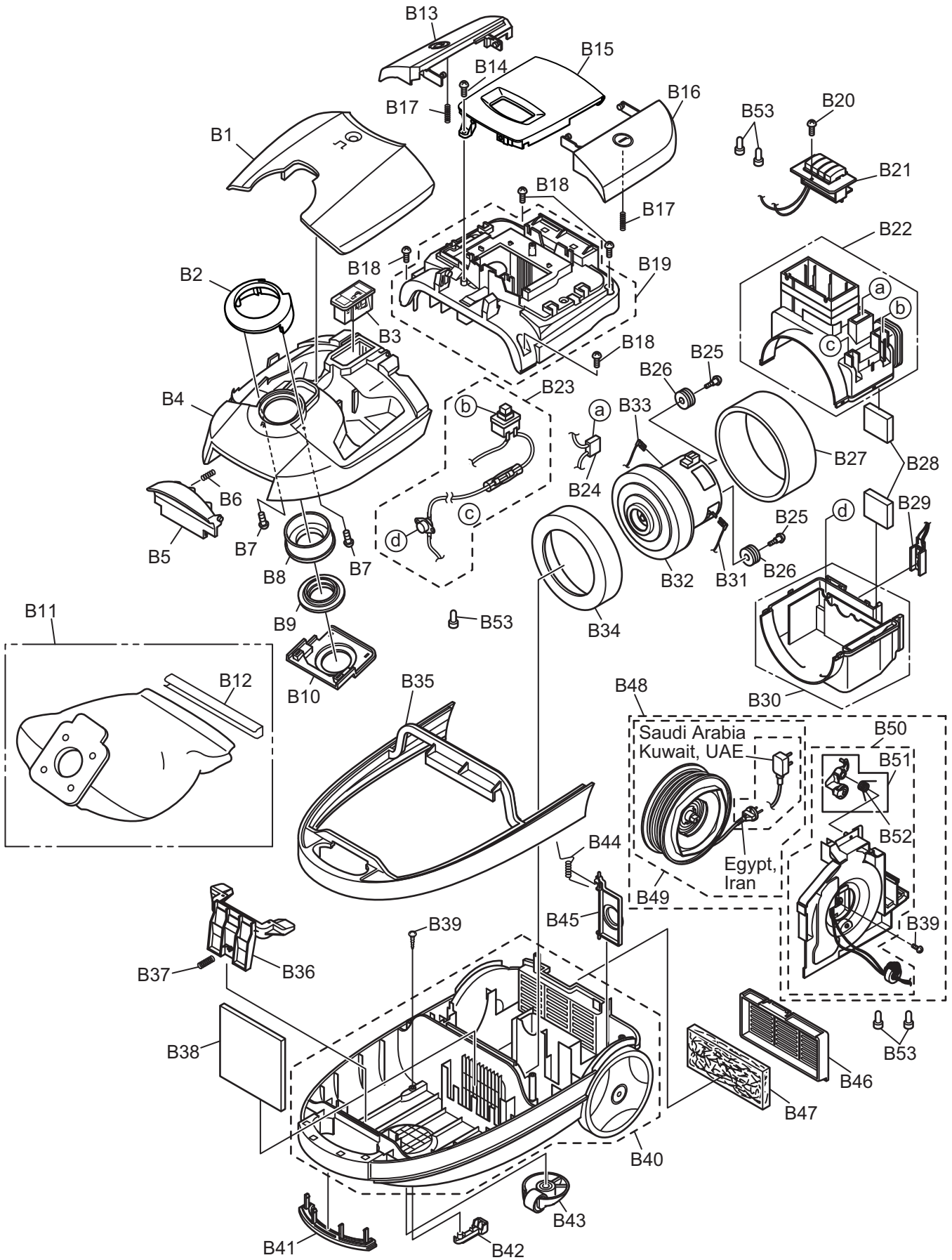

7.4. PARTS LIST (BODY UNIT)

Safety	Ref.No	Service Parts No.	Part Name & Description	Q'TY	Remarks
	B1	AMV83P9V0Q0J	TOOL STORAGE COVER	1	RED
	B1	AMV83P9V0K0J	TOOL STORAGE COVER	1	BRACK
	B2	AMV59H9U0S0J	FRONT MARK PRINT	1	
	B3	AMV98M9U000J	INDICATOR UNIT	1	(DAST INDICATOR)
	B4	AMV60K9U0Q0J	DUST COVER	1	RED
	B4	AMV60K9U0K0J	DUST COVER	1	BRACK
	B5	AMC01DUF0Q0J	DUST COVER CATCH	1	RED
	B5	AMC01D-UF0K	DUST COVER CATCH	1	BRACK
	B6	AMC18D-GA0	SPRING	1	
	B7	XTN4+12BFJ	SCREW	2	
	B8	AMC60H-GA0V	SUCTION INLET	1	
	B9	AMC64H-GA0	HOSE FITTING RUBBER	1	
	B10	AMC25K-UF0	DUST BOX PLATE	1	
	B11	AMC99K-UF0	DAST BAG	1	(CLOTH DAST BAG)
	B12	AMC23K-UG0	DAST BAG SUPPOTER	1	
	B13	AMV46N9U0K0J	CORD REWIND BUTTON	1	(CORD REWIND PEDAL)
	B14	XTN4+16BFJ	SCREW	1	
	B15	AMV92A9V0S0J	BODY COVER UNIT	1	
	B16	AMV05E9U0K0J	ON/OFF SWITCH BUTTON	1	(ON/OFF SWITCH PEDAL)
	B17	AMC71N-4P0	SPRING	2	
	B18	XTN4+20BFJ	SCREW	4	
	B19	AMV98A9U0Q0J	UPPER BODY UNIT	1	RED
	B19	AMV98A9U0K0J	UPPER BODY UNIT	1	BRACK
	B20	XTN3+10BFJ	SCREW	1	
△	B21	AMV89E9U0S0J	POWER CONTOROL SWITCH	1	
△	B22	AMC93F-UH0	MOTOR SUPPORT COVER U	1	
△	B23	AMC98E-UH0	ON/OFF SWITCH	1	With a Fuse (15A)
	B24	AMV46F9U000J	CAPACITOR	1	
	B25	AMC68A-1T0	SCREW	2	
	B26	AMC07F-1T0	MOTOR SUPPORT RUBBER	2	
△	B27	AMV99G9U000J	NOISE SUPPRESSOR UNIT	1	
	B28	AMC03L-UF0	GASKET A	2	
	B29	AMC39V-KM0	POWER CONTROL UNIT	1	
△	B30	AMC87F-UG0	MOTOR CASE U	1	
△	B31	AMC84GUG000J	YELLOW LEAD WIRE	1	YELLOW
△	B32	AMV0FF9U000J	MOTOR SET	1	
△	B33	AMC81GUG000J	RED LEAD WIRE	1	RED
	B34	AMC02F-UF0	MOTOR SUPPORT RUBBER(FRONT	1	
	B35	AMC31A-UF0K	FURNITURE GUARD	1	
	B36	AMC23K-UF0	DUST BAG HOLDER	1	
	B37	AMC46H-UF0	SPRING (FOR DUST BAG HOLDER)	1	
	B38	AMC30K-UF0	FILTER	1	(PRE MOTOR FILTER)
	B39	XTN4+16BFJ	SCREW	2	
	B40	AMC97AUF0K0J	LOWER BODY UNIT	1	
	B41	AMC06B-UF0K	HANDLE COVER	1	
	B42	AMC76P-UF0V	NOZZLE HOLDER	1	
	B43	AMC95C-0G0Z	CASTER UNIT	1	
	B44	AMC33L-UF0	SPRING (FOR BLOWER COVER	1	
	B45	AMC29L-UF0V	BLOWER COVER	1	
	B46	AMC01L-UF0V	REAR COVER	1	
	B47	AMC85L-UF0	EXHAUST PACKING U	1	(ANTI-BACTERIA FILTER)
△	B48	AMV91N9U003J	CORD REEL PARTITION UNIT	1	UAE
△	B48	AMV91N9U005J	CORD REEL PARTITION UNIT	1	SAUDI ARABIA, KUWAIT
△	B48	AMC91NUF00CJ	CORD REEL PARTITION UNIT	1	EGYPT, IRAN
△	B49	AMV99N9U005J	CORD REEL UNIT	1	SAUDI ARABIA, KUWAIT, UAE
△	B49	AMC99N-UF00C	CORD REEL UNIT	1	EGYPT, IRAN
	B50	AMC96AUF005J	BODY PARTITION ASSY	1	SAUDI ARABIA, KUWAIT
	B50	AMC96AUF000J	BODY PARTITION ASSY	1	EGYPT, UAE, IRAN
	B51	AMC94N-UF0	BLAKE LEVER U	1	
	B52	AMC47N-B80	BRAKE SPRING	1	
△	B53	CE-230	WIRE CONNECTOR	5	
△	-	AMC56L18000J	GASKET V	5	Glass Tape
	-	AMV61Z9V000J	INDIVIDUAL CARTON	1	SAUDI ARABIA, KUWAIT, UAE, IRAN
	-	AMV61Z9V00XJ	INDIVIDUAL CARTON	1	EGYPT
	-	AMC69Z-UF0	CUSHION A	1	
	-	AMV01Z9U000J	INSTRUCTION BOOK	1	
	-	AMC10Z-RD0	BODY BAG	1	
	-	AMV72Z9U000J	CUSHION PLATE A	1	