

Service Manual

Vacuum Cleaner

Model No. MC-CG717R249-AE

Destination: Iran

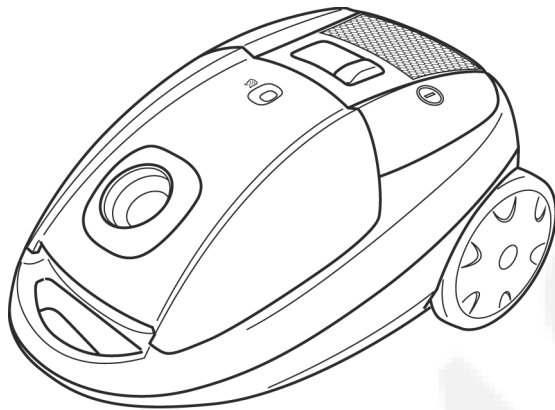

Subject : Change Specifications for Iran

Please file and use this supplement manual together with the service manual for Model No. MC-CG717, Order No. PMMA110825CE.

⚠ WARNING

This service information is designed for experienced repair technicians only and is not designed for use by the general public. It does not contain warnings or cautions to advise non-technical individuals of potential dangers in attempting to service a product. Products powered by electricity should be serviced or repaired only by experienced professional technicians. Any attempt to service or repair the product or products dealt with in this service information by anyone else could result in serious injury or death.

IMPORTANT SAFETY NOTICE

There are special components used in this equipment which are important for safety. These parts are marked by ⚠ in the Schematic Diagrams, Circuit Board Diagrams, Exploded Views and Replacement Parts List. It is essential that these critical parts should be replaced with manufacturer's specified parts to prevent shock, fire or other hazards. Do not modify the original design without permission of manufacturer.

TABLE OF CONTENTS

	PAGE		PAGE
1 Specifications -----	2	4.2. Attachment Exploded View -----	5
2 Schematic Diagram -----	2	4.3. Packing Instruction -----	6
3 Wiring Connection Diagram -----	3	4.4. Replacement Part List -----	7
4 Exploded View and Replacement Parts List -----	4	4.4.1. Part List -----	7
4.1. Exploded View -----	4		



© 2016 Panasonic Manufacturing Malaysia Berhad (6100-K). Unauthorized copying and distribution is a violation of law.

1 Specifications

Model	MC-CG717
Power Source	220V~240V~50/60Hz
Input Power (Max)	2300W
Input Power (IEC)	1600-2000W
Power Control	SLIDE
Dust Capacity	6.0L
Automatic Cord Rewind	O
Vac Gauge	O
Exhaust Filter	HEPA
Extension Wands	METAL TELESCOPIC WAND
Blower Operation	O
Floor Nozzle	2-STEP
Dust Bag	CLOTH
Dimension (H × W × L)	265mm × 320mm × 500mm
Net Weight	6.5 kg
Cord Length	5.0 m
Cleaning Tools	CREVICE TOOL / DUSTING BRUSH

2 Schematic Diagram

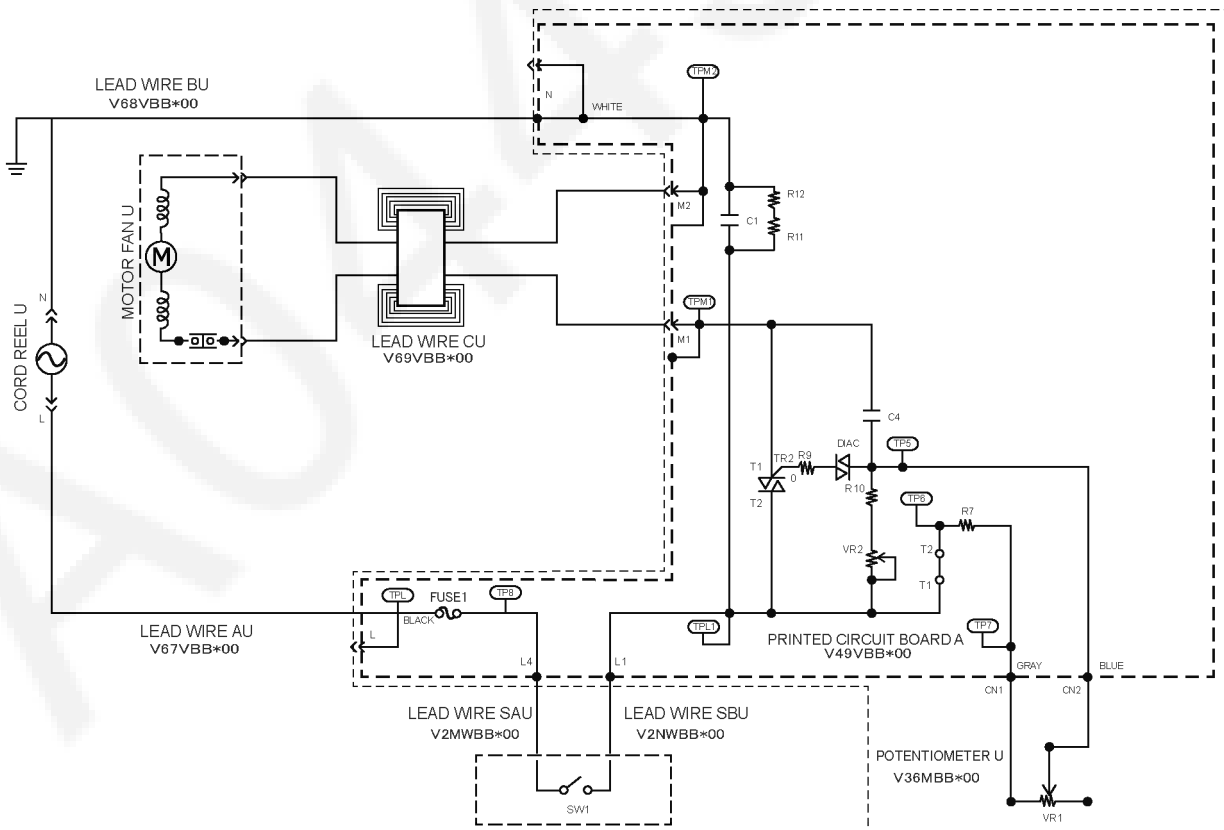

3 Wiring Connection Diagram

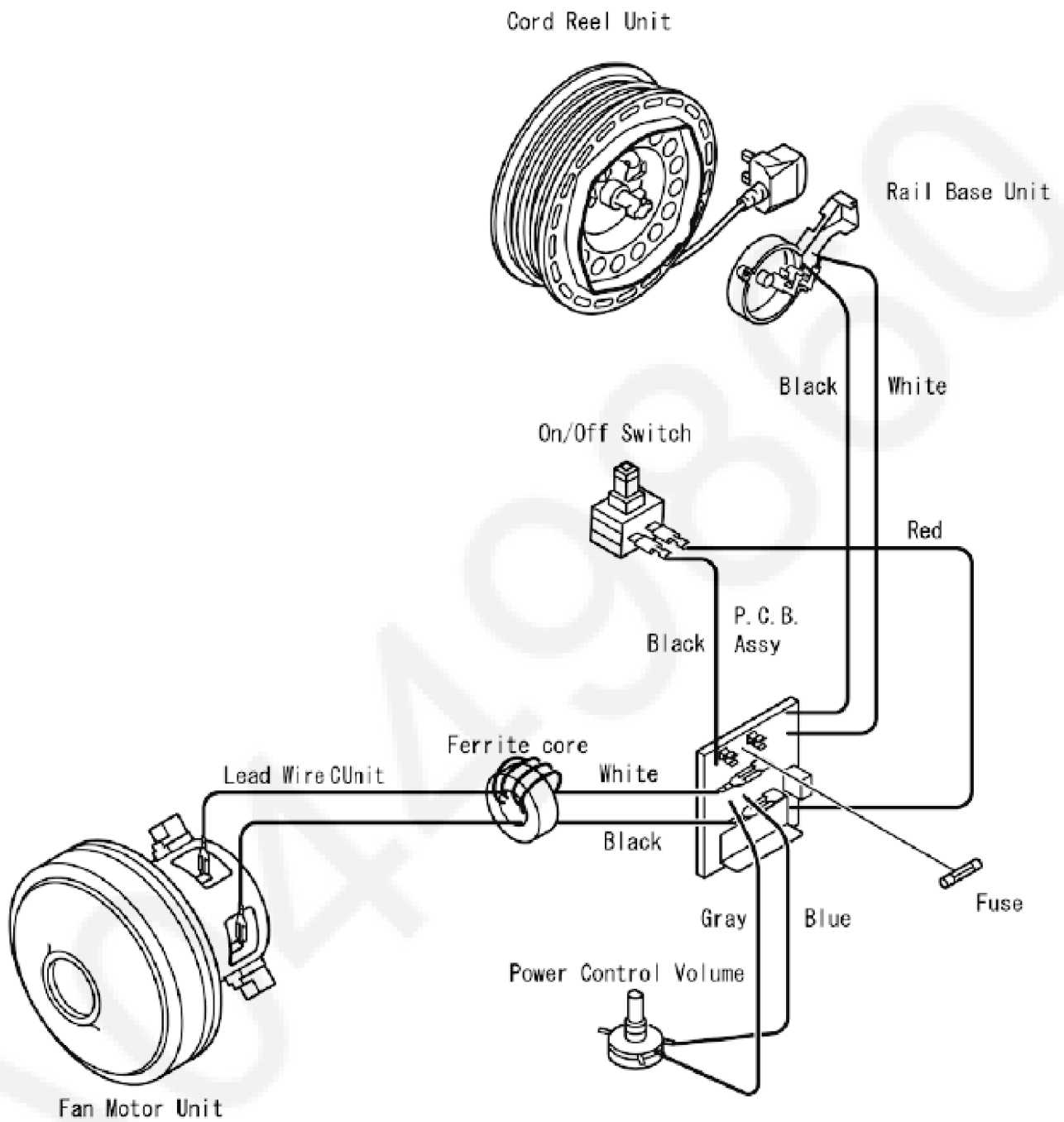

4 Exploded View and Replacement Parts List

4.1. Exploded View

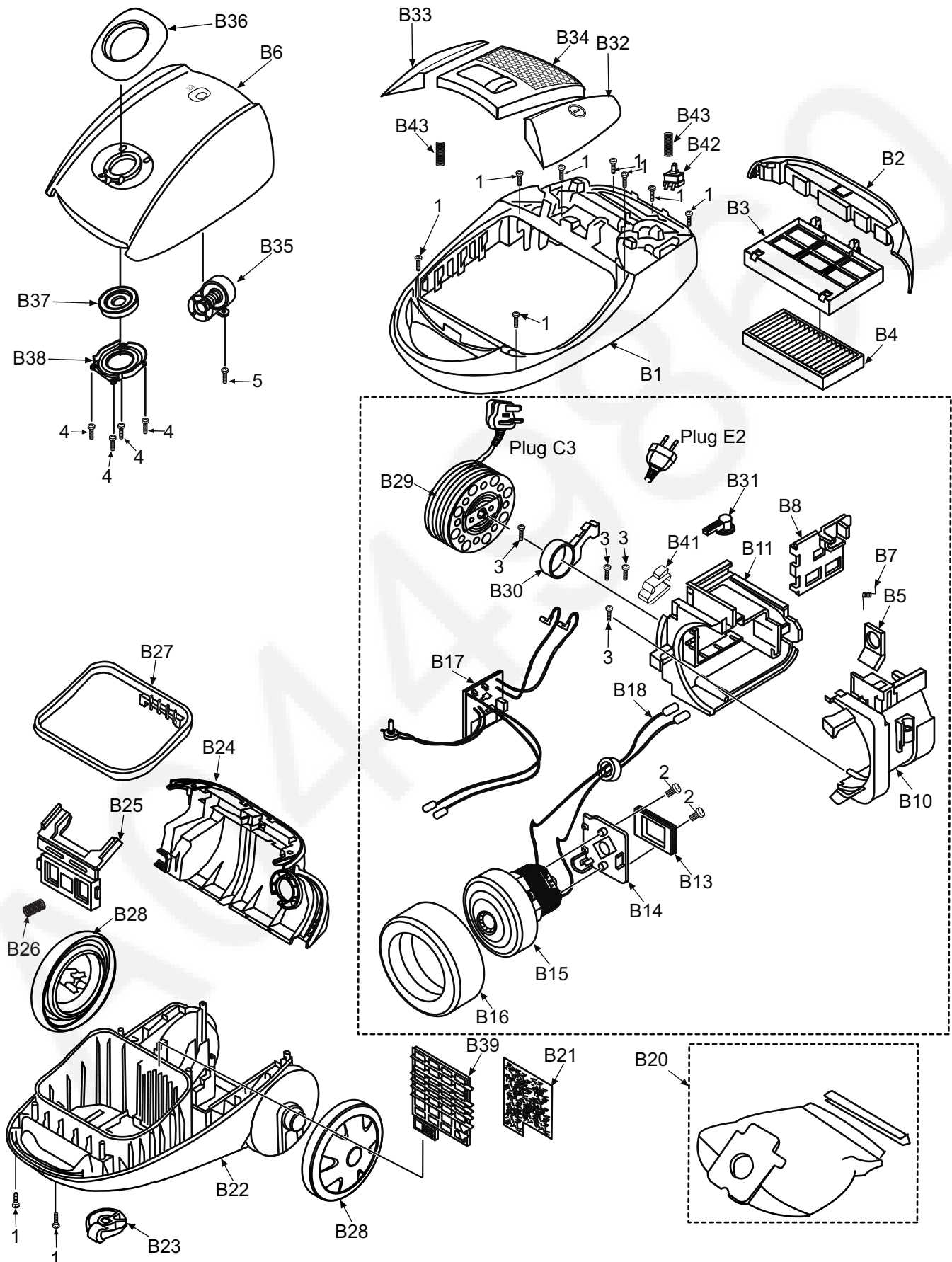

4.2. Attachment Exploded View

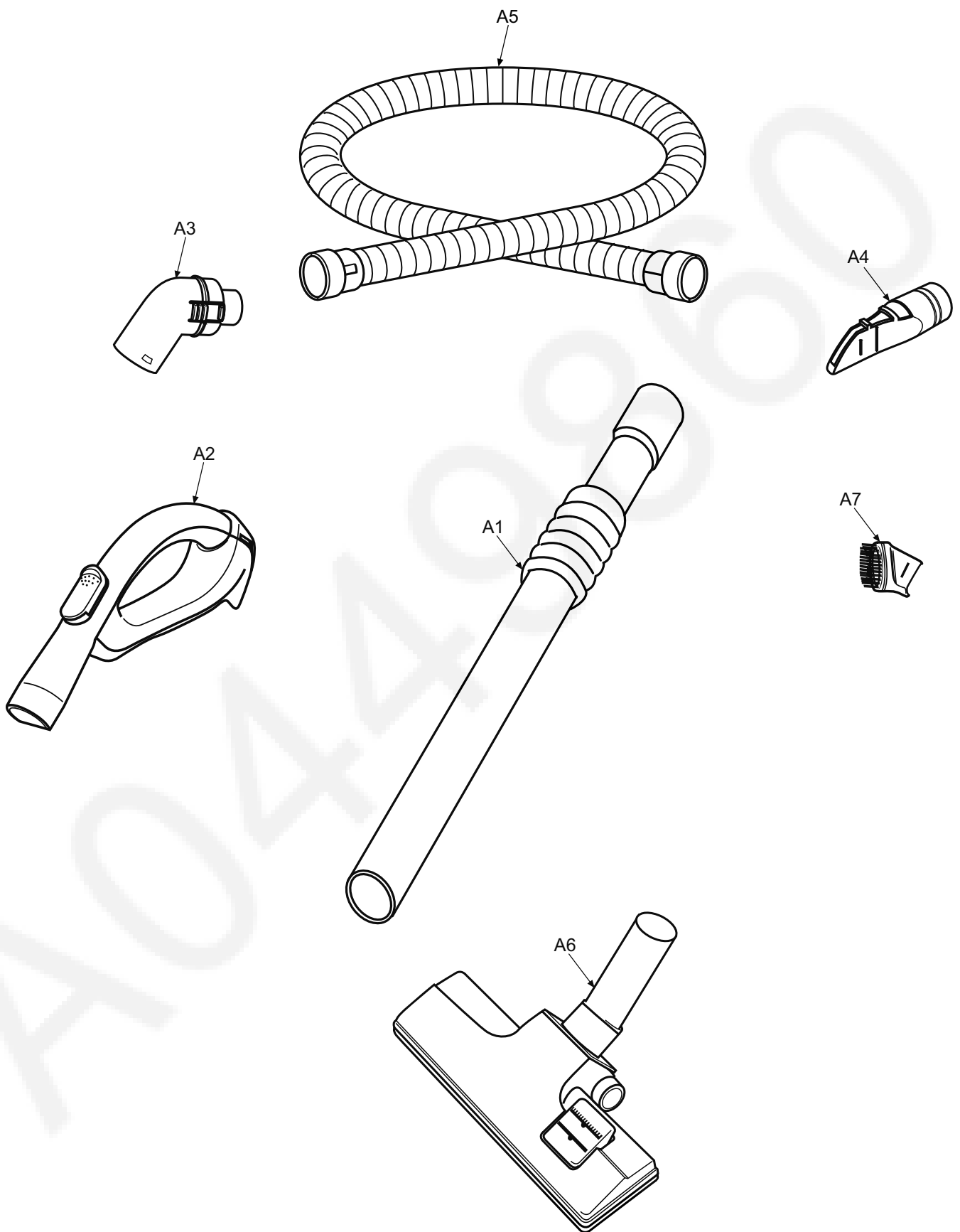

4.3. Packing Instruction

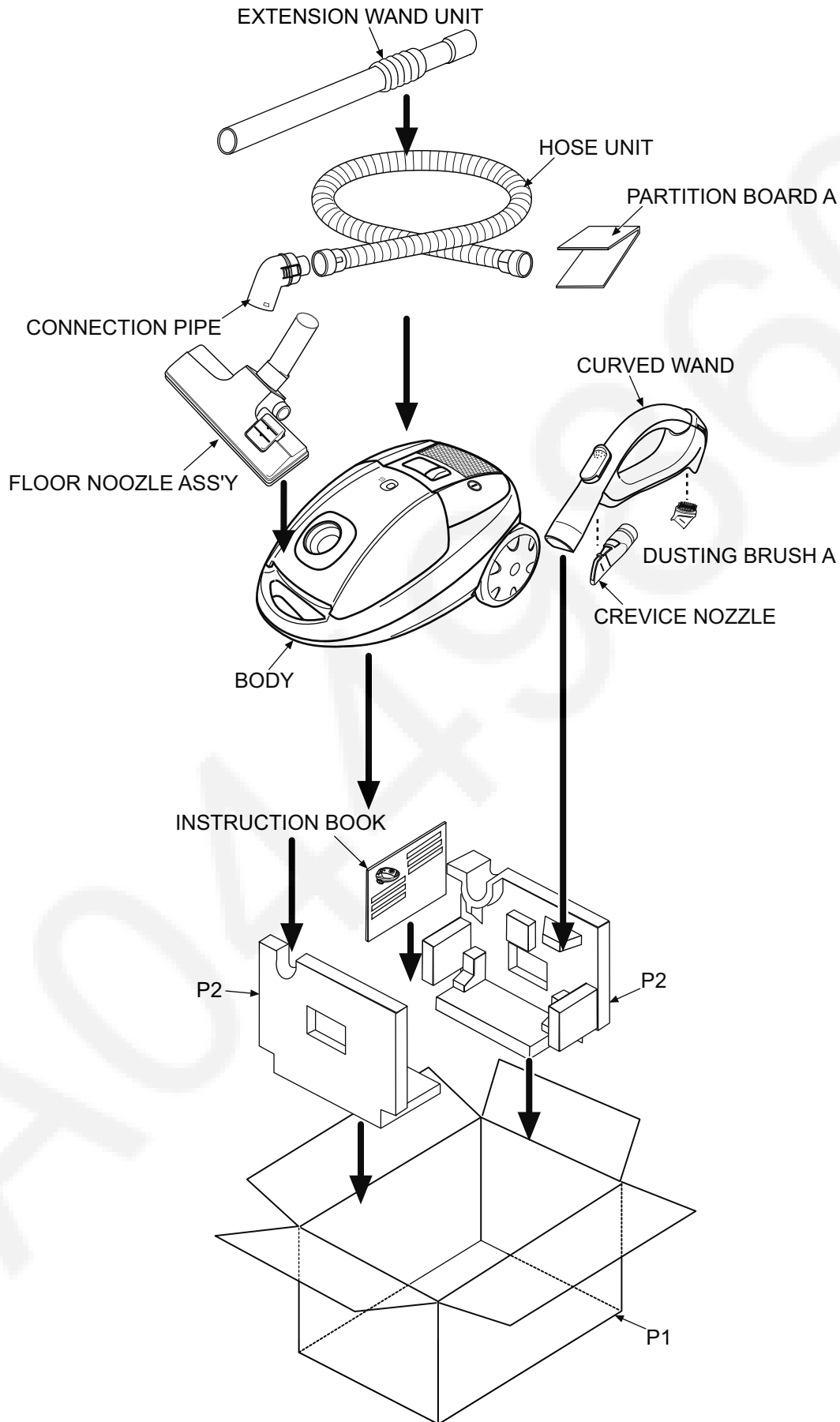

4.4. Replacement Part List

Important safety notice:

Components identified by \triangle mark have special characteristics important for safety.

When replacing any of these components, use only manufacturer's specified parts.

4.4.1. Part List

Safety	Ref. No.	Part No.	Part Name & Description	Qty	Remarks
	1	XTN4+20BFJ	PAN TAP SCREW	10	
	2	XTN4+10FFJ	SCREW	2	
	3	XTN4+14BFJ	TAPPING SCREW	4	
	4	XTN4+12BFJ	PAN TAP SCREW	4	
	5	XTN4+12BFJ	PAN TAP SCREW	1	
	B1	YMV02ABW000	UPPER BODY	1	
	B2	YMV32KBW000	FILTER SUPPORTER	1	
	B3	YMV42KBW000	FILTER CASE	1	
	B4	YMV95KBW000	FILTER ASS'Y	1	
	B5	YMV96LBW000	BLOWER OUTLET UNIT	1	
	B6	YMV92LBW0RI	DUST COVER UNIT	1	
	B7	YMV33LBW000	BLOWER COVER SPRING	1	
	B8	YMV59VBW000	PCB HOLDER	1	
	B10	YMV63FBW000	MOTOR SUPPORT COVER	1	
	B11	YMV09FBW100	MOTOR CASE	1	
	B13	YMV02FBY100	MOTOR SUPP. RUBBER FRONT	1	
	B14	YMV07FBW000	MOTOR SUPPORT FRONT	1	
\triangle	B15	YMV92FBW00I	MOTOR FAN UNIT	1	
	B16	YMV03FBW000	MOTOR SUPPORT RUBBER REAR	1	
\triangle	B17	YMV89VB6000	PCB A UNIT	1	
\triangle	B18	YMV69VBX000	LEAD WIRE C UNIT	1	
	B20	YMC99KXQ100	CLOTH BAG UNIT	1	
	B21	YMV37KBW000	SECONDARY FILTER	1	
	B22	YMV03ABW200	LOWER BODY	1	
	B23	YMC95C7K100	CASTER UNIT	1	
	B24	YMV01LBW100	REAR COVER	1	
	B25	YMV23KBW000	SUPPORTER	1	
	B26	YMV46HBW000	BAG CLAMPER SPRING	1	
	B27	YMV73KBW100	DUST BOX PACKING	1	
	B28	YMV01CBW000	WHEEL	2	
\triangle	B29	YMV99NBW00Q	CORD REEL UNIT	1	E2 PLUG
\triangle	B30	YMV98NBW000	RAIL BASE UNIT	1	
	B31	YMV25QBW000	SWIVEL CAP	1	
	B32	YMV05EBW000	SWITCH PEDAL	1	
	B33	YMV46NBW000	CORD REWIND BUTTON	1	
	B34	YMV02GBY000	BODY LINING UPPER	1	
	B35	YMV99MCH100	INDICATER UNIT	1	
	B36	YMV63HBW000	FRONT MARK	1	
	B37	YMV64HBW000	SUCTION INLET PACKING	1	
	B38	YMV25KBW000	DUST BOX PLATE	1	
	B39	YMV43KBW000	PRE FILTER	1	
	B41	YMV43NBW000	BRAKE LEVER	1	
\triangle	B42	YMV01E7B000	ON / OFF SWITCH	1	
	B43	YMV71NBW000	SPRING BRAKE BUTTON	2	
	A1	YMV99PBW000	METAL WAND TELESCOPIC	1	
	A2	YMV98PBW000	CURVE WAND UNIT	1	
	A3	YMV27HBW000	CONNECTION WAND	1	
	A4	YMV60R9L080	CREVICE NOZZLE	1	
	A5	YMC84PXP200-P	HOSE UNIT	1	
	A6	YMC99RXQ000	FLOOR NOZZLE ASS'Y	1	
	A7	YMC88RYX080	DUSTING BRUSH UNIT	1	
	P1	YMV61ZBW000	INDIVIDUAL CARTON	1	
	P2	YMV98ZBX000	CUSHION UNIT	1	
\triangle		YMV01ZBW100	INSTRUCTION MANUAL	1	