

Service Manual

Vacuum Cleaner

Model No. MC-CG715

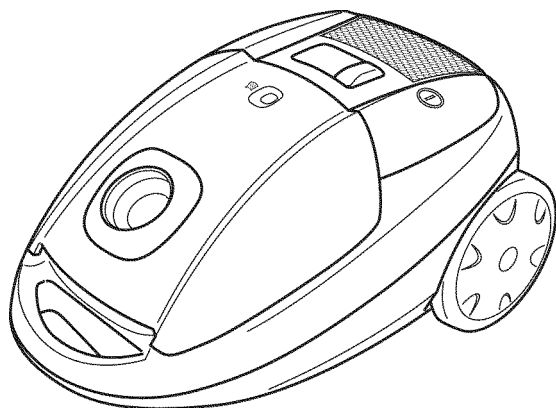

⚠ WARNING

This service information is designed for experienced repair technicians only and is not designed for use by the general public. It does not contain warnings or cautions to advise non-technical individuals of potential dangers in attempting to service a product. Products powered by electricity should be serviced or repaired only by experienced professional technicians. Any attempt to service or repair the product or products dealt with in this service information by anyone else could result in serious injury or death.

IMPORTANT SAFETY NOTICE

There are special components used in this equipment which are important for safety. These parts are marked by ⚠ in the Schematic Diagrams, Circuit Board Diagrams, Exploded Views and Replacement Parts List. It is essential that these critical parts should be replaced with manufacturer's specified parts to prevent shock, fire or other hazards. Do not modify the original design without permission of manufacturer.

TABLE OF CONTENTS

	PAGE		PAGE
1 Specifications	2	6.4. Replacement Parts List	16
2 Schematic Diagram	2		
3 Wiring Connection Diagram	3		
4 Trouble Shooting Chart	4		
5 Disassembly and Assembly Instruction	6		
5.1. Disassembly of Upper and Lower Body	6		
5.2. Disassembly of Body Lining Upper	7		
5.3. Disassembly of Switch Pedal.....	8		
5.4. Disassembly of Cord Rewind Button	9		
5.5. Disassembly of Motor Case Set	9		
5.6. Disassembly of Cord Reel Unit	10		
5.7. Disassembly of Rail Base Unit.....	10		
5.8. Disassembly of Fan Motor Unit	11		
5.9. Disassembly of P.C.B. Ass'y.....	12		
6 Exploded View and Replacement Parts List	13		
6.1. Exploded View	13		
6.2. Attachment Exploded View	14		
6.3. Packing Instruction	15		

1 Specifications

Model	MC-CG715
Power Source	220V~240V~50/60Hz
Input Power (Max)	2100W
Input Power (IEC)	1550-1900W
Power Control	SLIDE
Dust Capacity	6.0L
Automatic Cord Rewind	0
Vac Gauge	0
Exhaust Filter	HEPA
Extension Wands	MAGIC TELESCOPIC WAND
Blower Operation	0
Floor Nozzle	2-STEP
Dust Bag	CLOTH
Dimension (H x W x L) mm	265mm X 320mm X 500mm
Net Weight	6.1 KG
Cord Length	5.0 M
Cleaning Tools	CREVICE TOOL / DUSTING BRUSH

2 Schematic Diagram

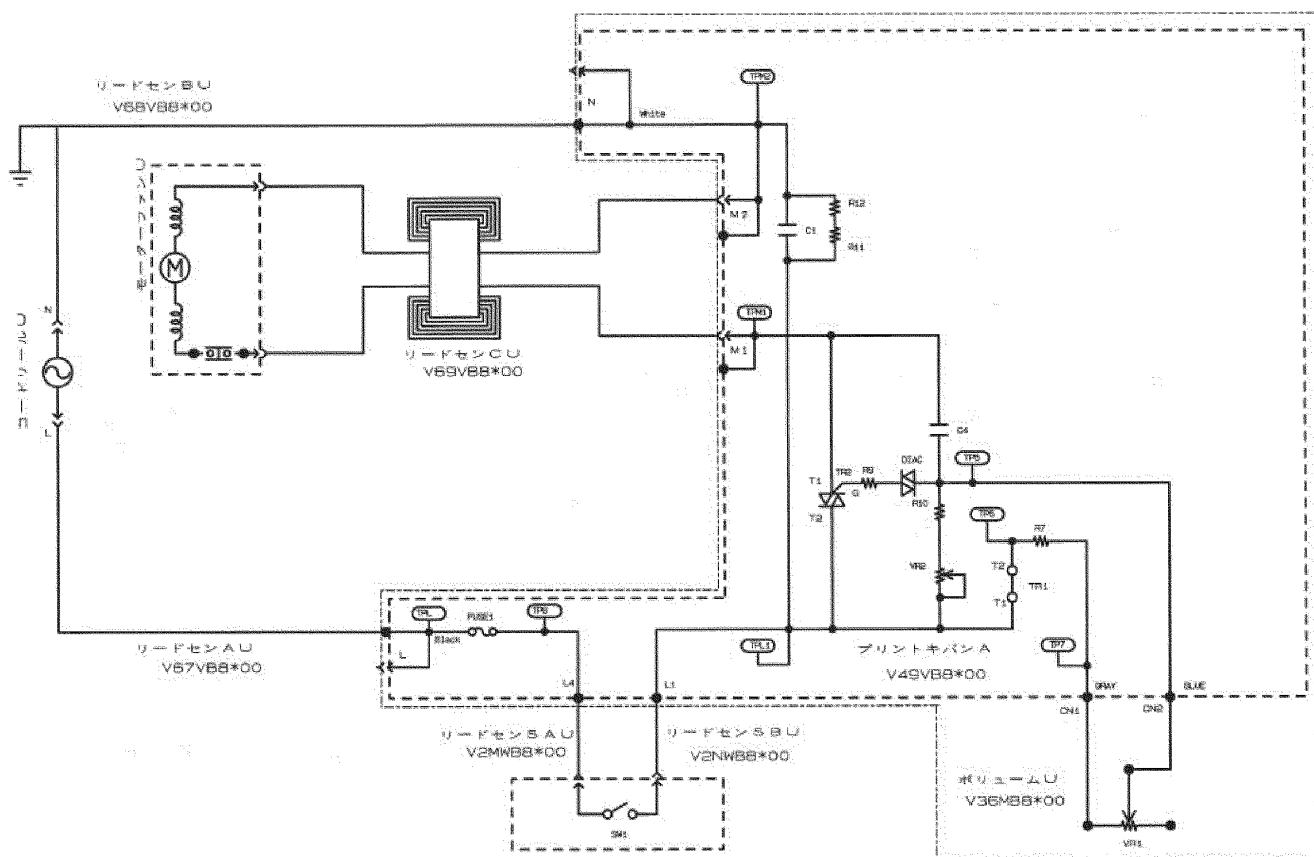

3 Wiring Connection Diagram

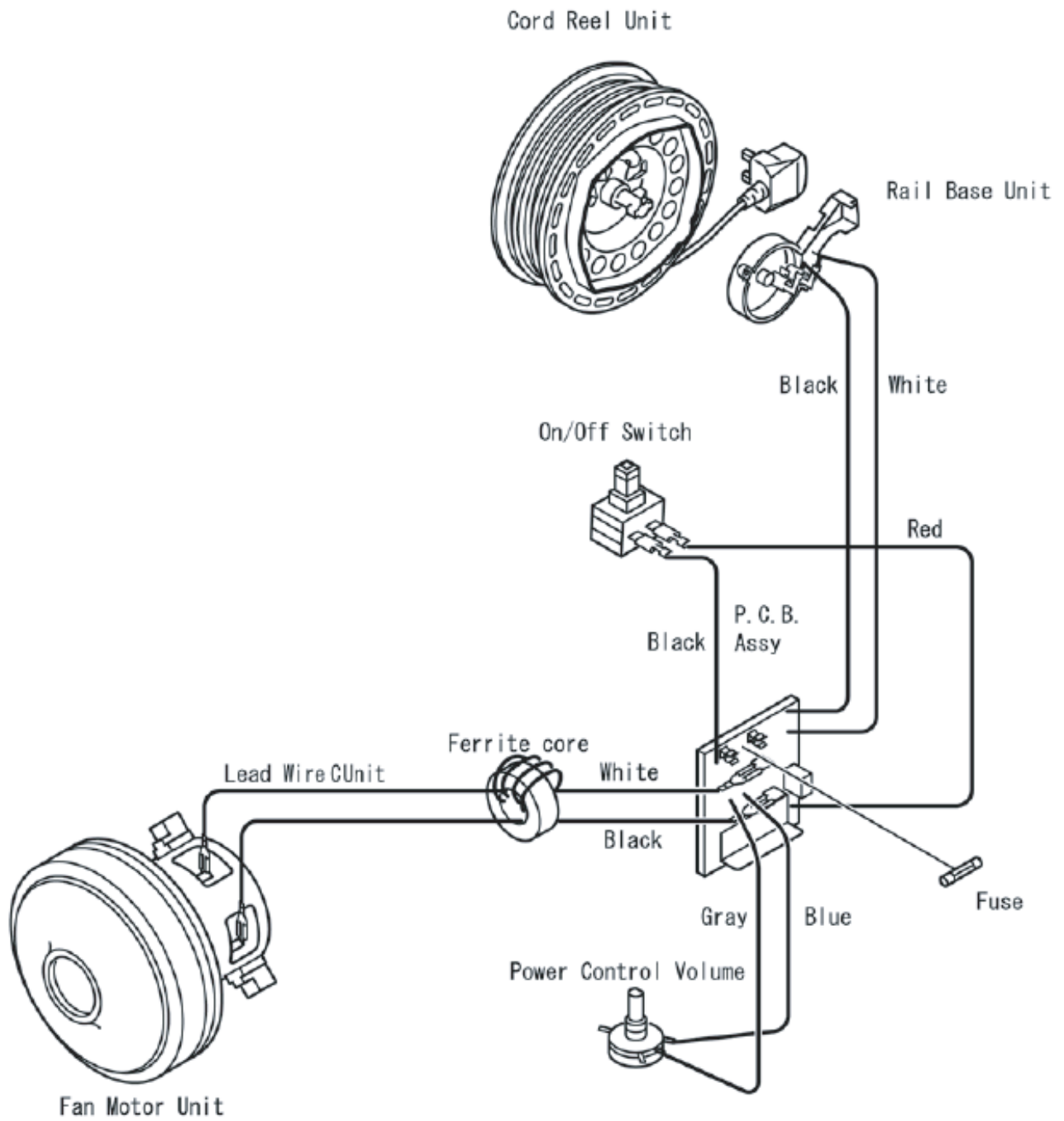

4 Trouble Shooting Chart

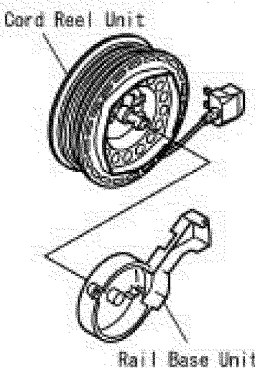
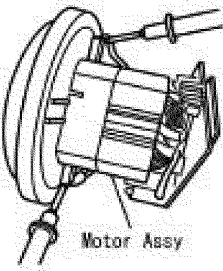
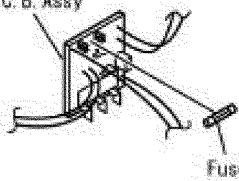
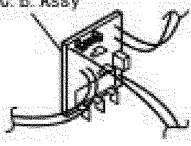
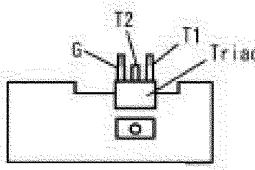
CONDITION	CHECKPOINT	FIGURE	CHECK METHOD	REMEDY
The Motor doesn't rotate.	CORD REEL UNIT RAIL BASE UNIT	 <p>Cord Reel Unit</p> <p>Rail Base Unit</p>	<ul style="list-style-type: none"> • Check the continuity at both ends of the Plug and both ends of the Lead Wire Terminal of the Cord Reel Unit. (Disconnection check) • There must be no problems between the Cord Reel Unit and the Rail Base Unit (e.g. burms in the contact, entry of dust). 	<ul style="list-style-type: none"> • If there is no continuity, replace the Cord Reel Unit, or the Rail Base Unit.
	MOTOR	 <p>Motor Assy</p>	<ul style="list-style-type: none"> • Check the continuity between the terminals of the Motor. • Confirm that the Motor can be rotated by fingers without being locked. • Visually check for burms in the Motor (e.g. burms in the coil). 	<ul style="list-style-type: none"> • If there is a problem, replace the Motor Assy. • * Also check and replace the Fuse (on the P.C.B. Assy)
	FUSE	 <p>P. C. B. Assy</p> <p>Fuse</p>	<ul style="list-style-type: none"> • Check if the Fuse has blown. Causes of fuse blowing: <ol style="list-style-type: none"> 1. Overcurrent 2. Burn of the Motor 3. Short-circuiting due to incorrect wiring 	<ul style="list-style-type: none"> • If the Fuse has blown, remove the cause and replace the Fuse. • *If a burn in the Motor caused the Fuse to blow, then also replace the Motor.
	P.C.B. ASSY	 <p>P. C. B. Assy</p>	<ul style="list-style-type: none"> • Check the internal components for problems. (Burnt, melted, broken, etc.) • There must be no broken foil of the Printed Circuit Board. • There must be no breaks in the Lead Wires. 	<ul style="list-style-type: none"> • If there is a problem, replace the P.C.B. Assy.
	TRIAC (on the P.C.B. Assy)	 <p>T2</p> <p>T1</p> <p>G</p> <p>Triac</p>	<ul style="list-style-type: none"> • Check the Triac by conducting the following inspection. <div style="background-color: #cccccc; padding: 5px; text-align: center; font-weight: bold;">Check the Triac on the P.C.B. Assy</div> <p>*Using a tester, see if continuity is detected between each pair of Triac legs. The normality are as follows.</p> <ol style="list-style-type: none"> 1. T1 - T2 : No continuity 2. T2 - G : No continuity 3. T1 - G : Continuity <p>*Connect the T1 side to the positive side of the tester, and then check the continuity.</p>	<ul style="list-style-type: none"> • If there is a problem, replace the P.C.B. Assy.

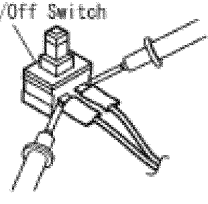
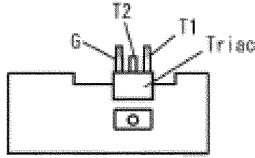
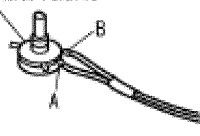
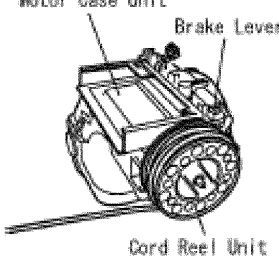
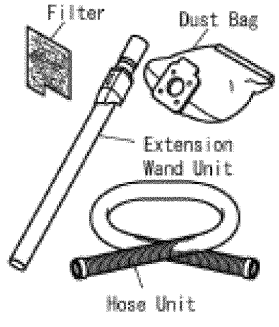
CONDITION	CHECKPOINT	FIGURE	CHECK METHOD	REMEDY
	ON/OFF SWITCH (in the P.C.B. Assy)		<ul style="list-style-type: none"> Check the continuity by pressing the On/Off Switch. 	<ul style="list-style-type: none"> If there is a problem, replace the P.C.B. Assy.
1. The Motor doesn't rotate. 2. The Power Control doesn't function.	TRIAC (on the P.C.B. Assy)		<ul style="list-style-type: none"> Check that the Triac has not been short-circuited. If there is continuity between T1 and T2, then there is a problem in the components. 	<ul style="list-style-type: none"> If there is a problem, replace the P.C.B. Assy.
	POWER CONTROL VOLUME (in the P.C.B. Assy)		<ul style="list-style-type: none"> The resistance between A and B must be switchable. 0~470Ω 	<ul style="list-style-type: none"> If there is a problem, replace the P.C.B. Assy.
The Cord cannot be pulled out.	CORD REEL UNIT MOTOR CASE UNIT		<ul style="list-style-type: none"> If the Cord cannot be pulled out, press the Brake Lever and confirm that the Cord can be rewound. Repeat operations to rewind and pull out the Cord two or three times and confirm that it can be normally rewound. 	<ul style="list-style-type: none"> If it is impossible to resolve the problem due to an abnormal condition of the Cord, separate the Body, untwist the Cord, and rewind it. Or, replace the Cord Reel Unit and rewind the Cord.
1. The Cord cannot be rewound. 2. The pulled out Cord cannot be locked.			<ul style="list-style-type: none"> Separate the Body and; <ul style="list-style-type: none"> Confirm that a sufficient number of spare turns have been made. Confirm that the Cord Reel Spring is working. Confirm that the Brake Lever Unit is working correctly to stop the Cord from rewinding. 	<ul style="list-style-type: none"> Make spare turns according to the engraved number of turns, or; Replace the Cord Reel Unit. Replace the Motor Case Unit.
1. The suction power is low. 2. The Motor stops during vacuuming. (The Thermo Protector in the Motor Assy works.)	DUST BAG FILTER EXTENSION WAND UNIT HOSE UNIT		<ul style="list-style-type: none"> Check for clogging with dust. <ul style="list-style-type: none"> Dust Bag Filter (in the Dust Box) Hose Unit Extension Wand Unit 	<ul style="list-style-type: none"> Remove dust. <ul style="list-style-type: none"> Replace any broken Dust Bag, Filter, and/or Hose Unit.

5 Disassembly and Assembly Instruction

5.1. Disassembly of Upper and Lower Body

Step 1 Open the Dust Cover.

Step 2 Remove the Dust Bag.

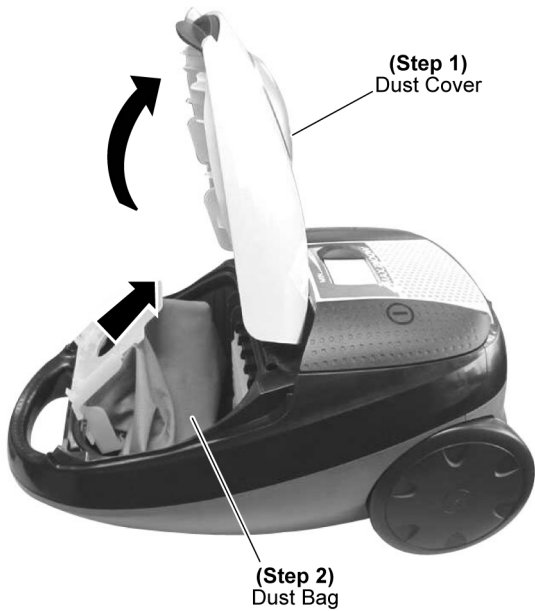

Step 3 Remove 4 screws from the front side and 2 screws from bottom side of the body.

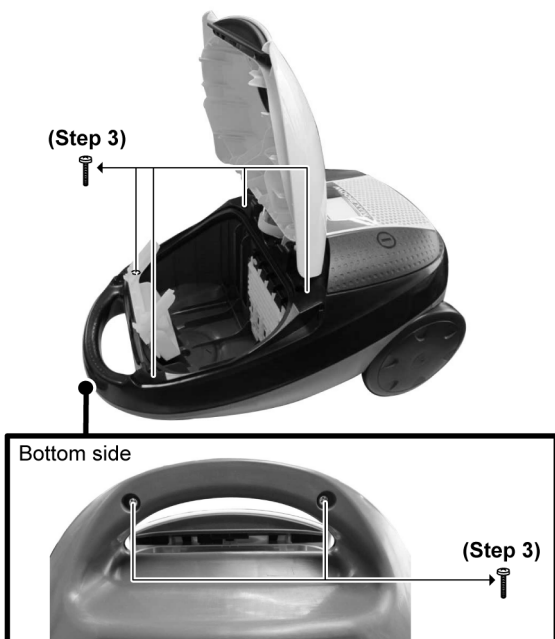

Step 4 Pull out the Exhaust Cover.

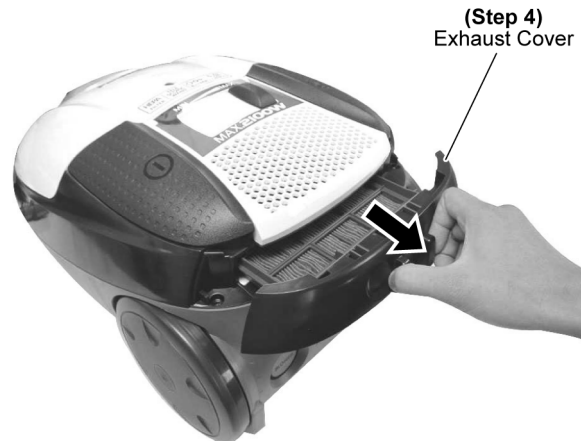

Step 5 Remove 3 screws from back side of the body.



Step 6 Lift up the Upper Body while holding Lower Body.

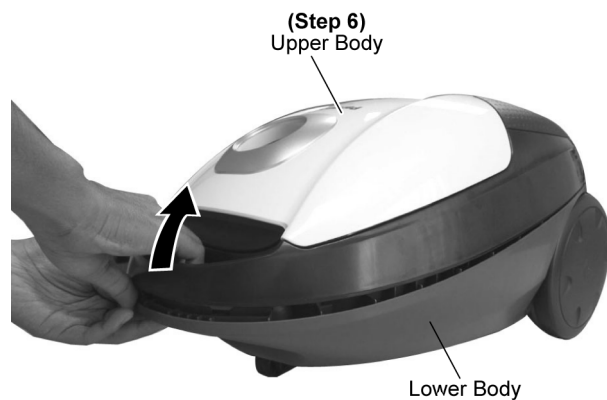

Step 7 Place the set as diagram shown and disconnect the Wire Terminal from switch at the Upper Body.

Caution: Remove tape that wrap Wire Terminal and Switch before disconnect it.

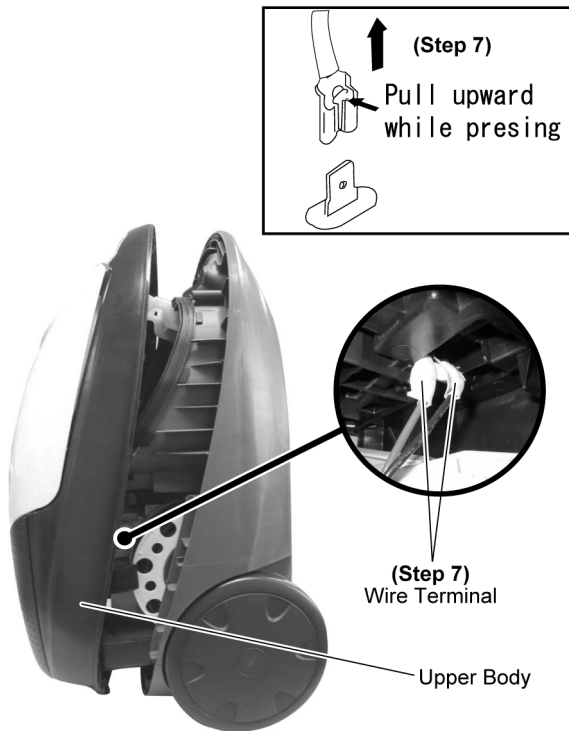

Step 8 Remove the Upper Body from Lower Body.

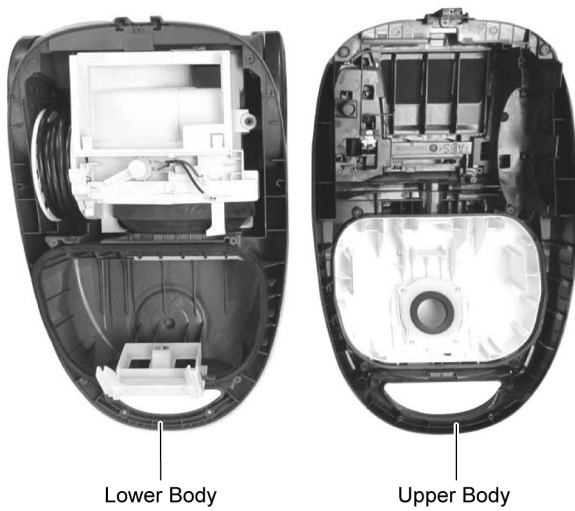

5.2. Disassembly of Body Lining Upper

Step 1 Place the Upper Body as diagram shown and open the Dust Cover.

Step 2 Remove 1 screw.



Step 3 Place the Upper Body as diagram shown and release Catch.

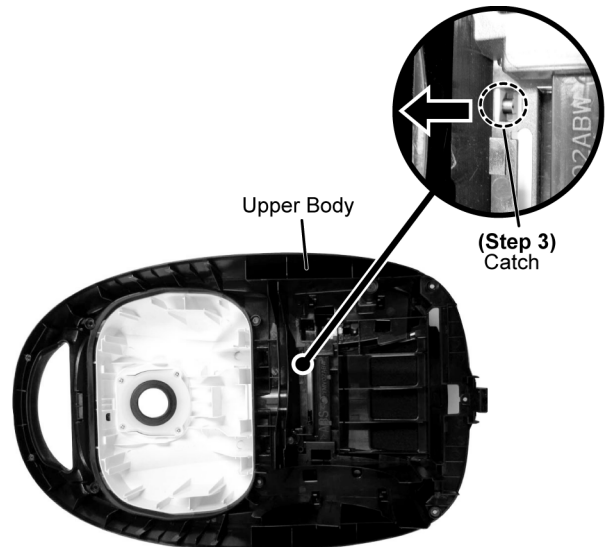

Step 4 Place the Upper Body as diagram shown and take out the Body Lining Upper

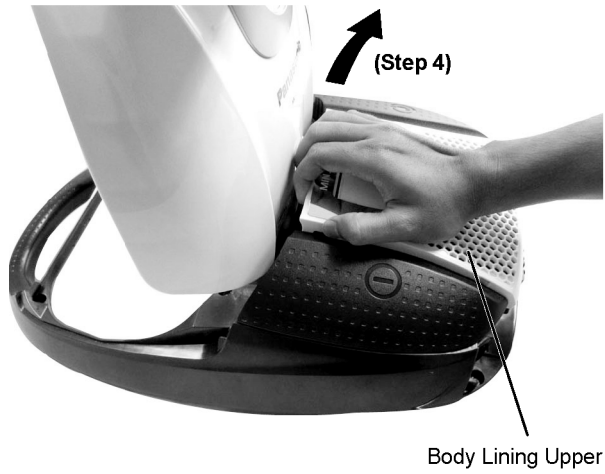

5.3. Disassembly of Switch Pedal

Step 1 Place the Upper Body as diagram shown and release Catches.

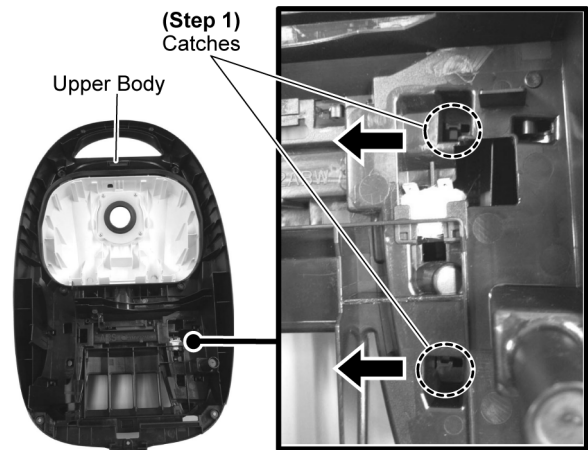

Step 2 Remove Switch.



5.4. Disassembly of Cord Rewind Button

Step 1 Place the Upper Body as diagram shown and release Catches.

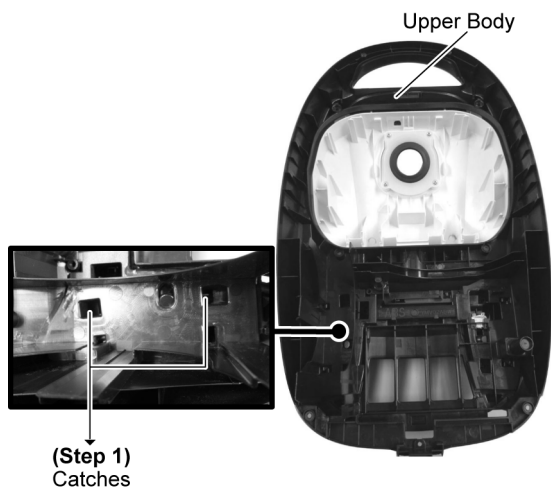

5.5. Disassembly of Motor Case Set

Step 1 Release Rear Cover from Screw Holders.

Step 2 Remove Rear Cover.



Step 3 Pull up the Motor Case Set from the Lower Body.

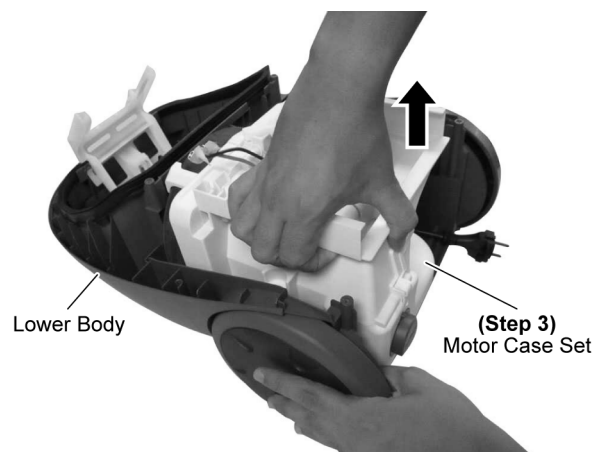

5.6. Disassembly of Cord Reel Unit

Step 1 Release the pretension of the Cord Reel Unit slowly by holding on the Power Plug and pressing on the Brake Lever.

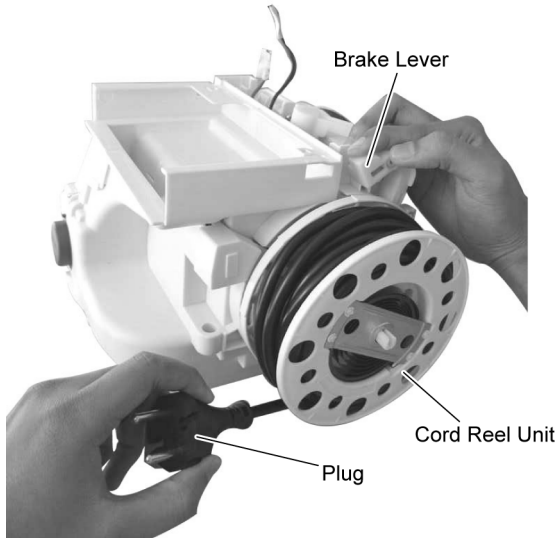

Step 2 Remove the Cord Reel Unit from the Motor Case Set by inserting a slotted screwdriver into the shaft of the Cord Reel Unit and turning it 90° counter-clockwise.

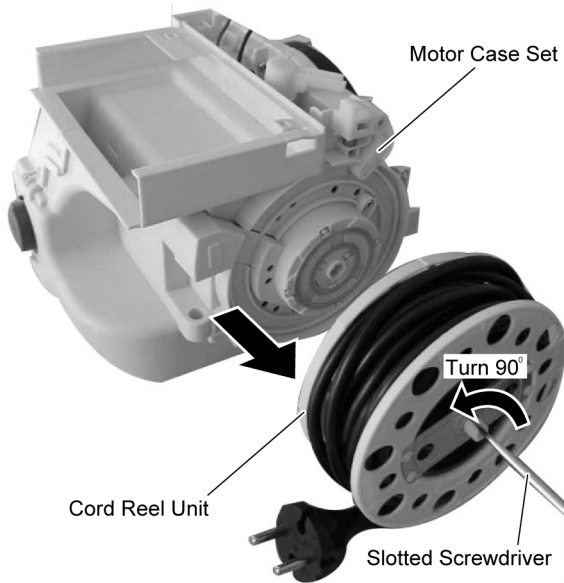

To assemble:

Step 1 Assemble in reverse order of the disassembly.

Step 2 Pretension the Cord Reel Unit.

- Turn the Cord Reel Unit holding on the plug
- Number of turns for pretension of the Cord is engraved on the steel at the side of Cord Reel Unit.

5.7. Disassembly of Rail Base Unit

Step 1 Remove 1 screw.

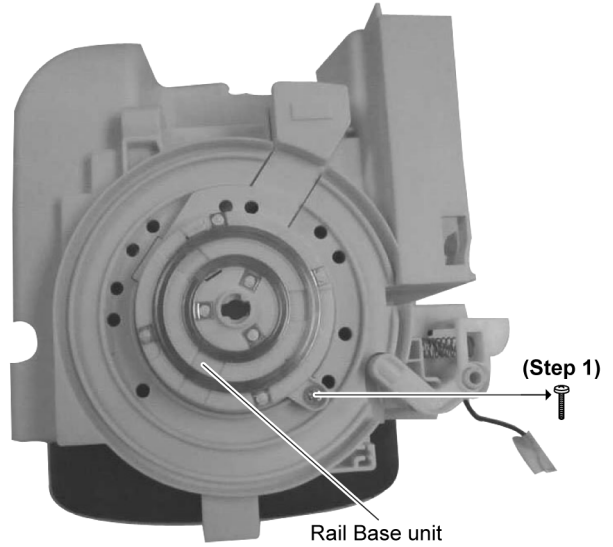

Step 2 Release Catch and pull upward.

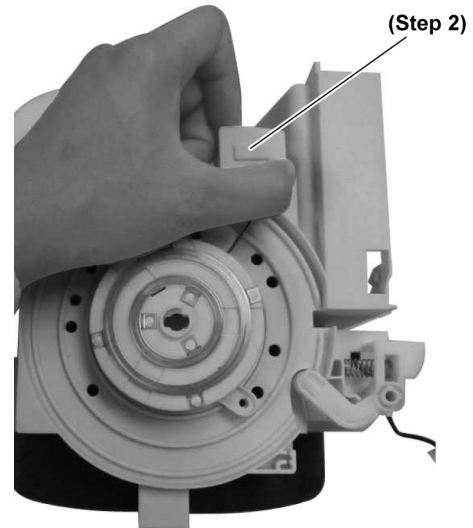

Step 3 Remove Faston Terminals on Rail Base Unit.

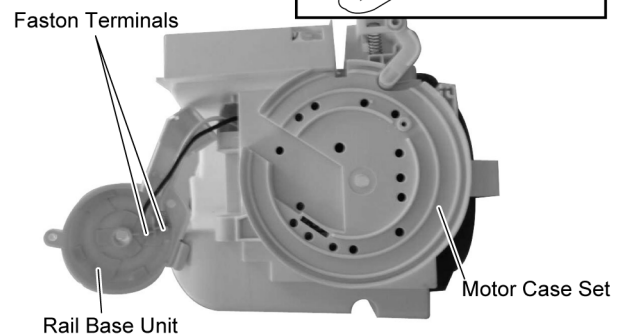
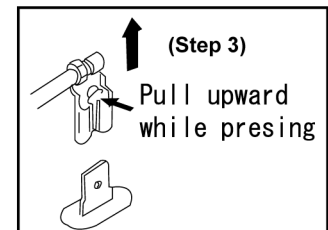

5.8. Disassembly of Fan Motor Unit

Step 1 Remove Swivel Cap.

Step 2 Remove 1 screw from top and 2 screws bottom Motor Case Set.

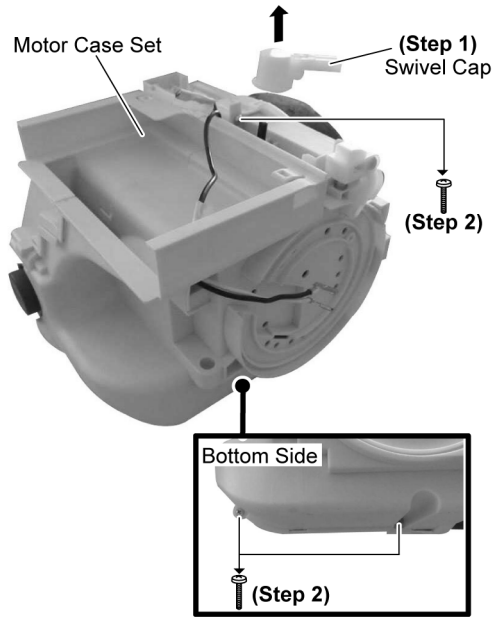

Step 3 Remove Tabs.

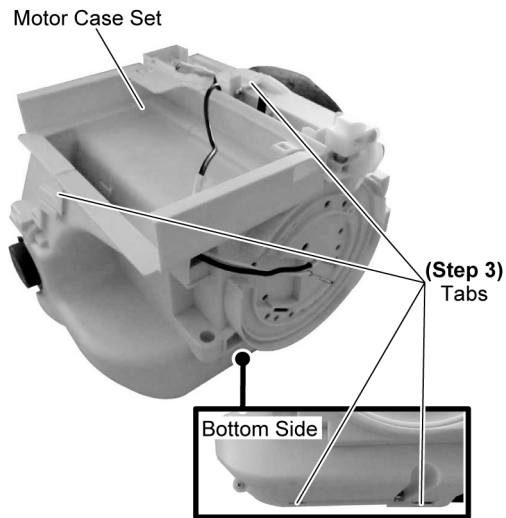

Step 4 Lift up the Motor Case Unit.

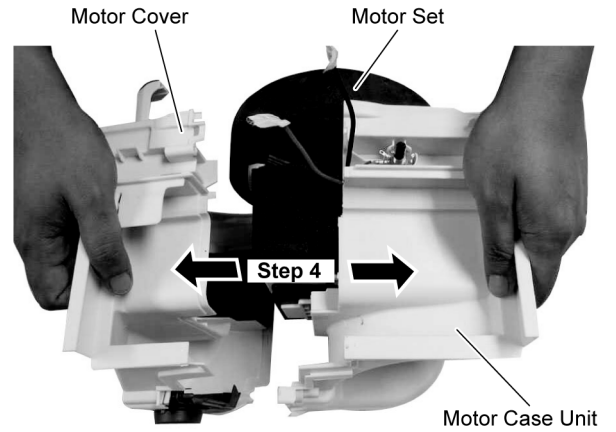

Step 5 Disconnect the Wire Terminal and remove the Motor Set.

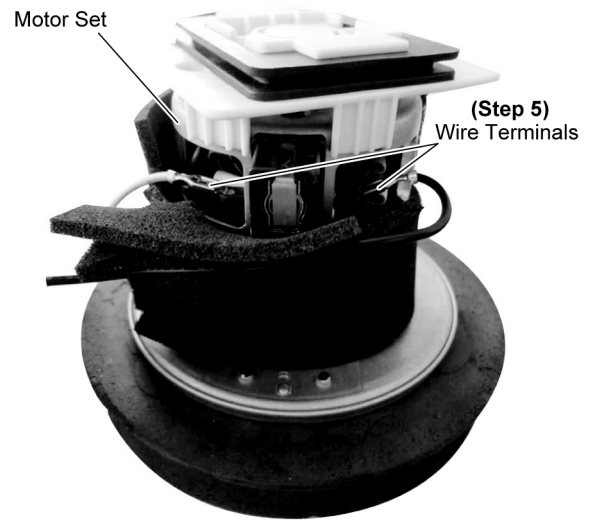

Step 6 Remove the Noise Suppressor Unit and Motor Support Rubbers.

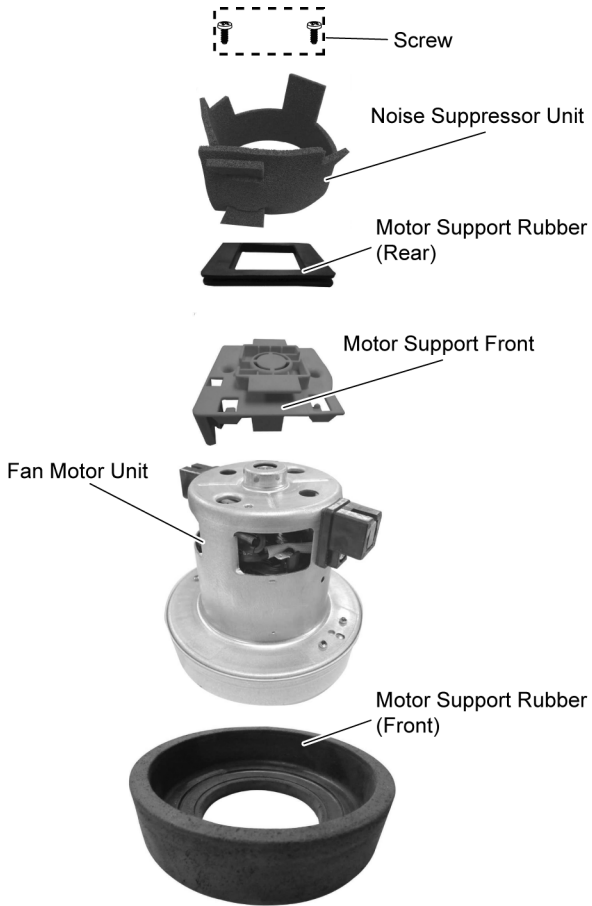

5.9. Disassembly of P.C.B. Ass'y

Step 1 Disassemble the Power Control Volume by widening the Tab using Screwdriver.

Step 2 Remove Power Control Volume Upward.

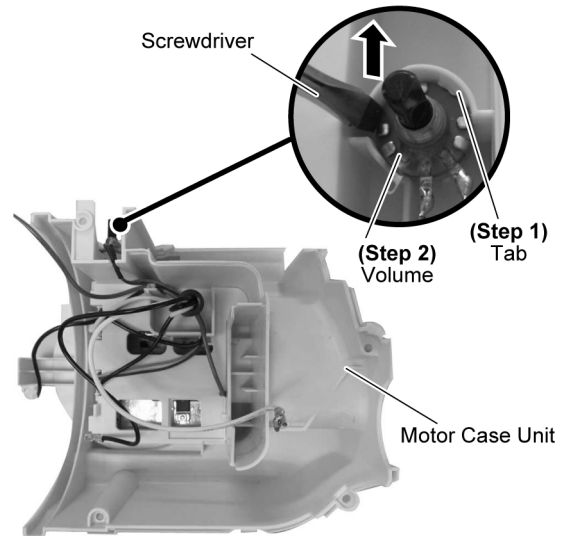

Step 3 Release Tabs and remove P.C.B. Cover.

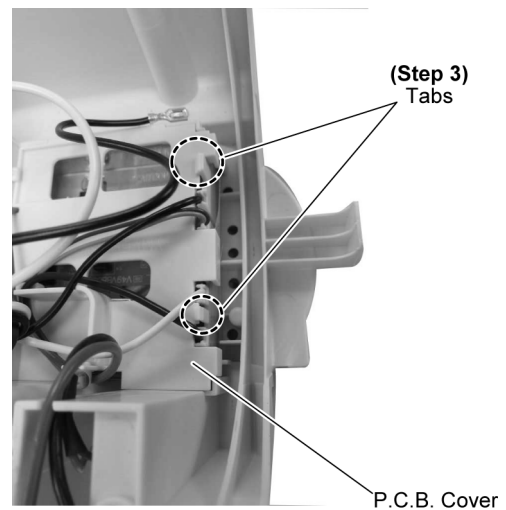

To reassemble the unit, reverse the disassembly procedure above.

6 Exploded View and Replacement Parts List

6.1. Exploded View

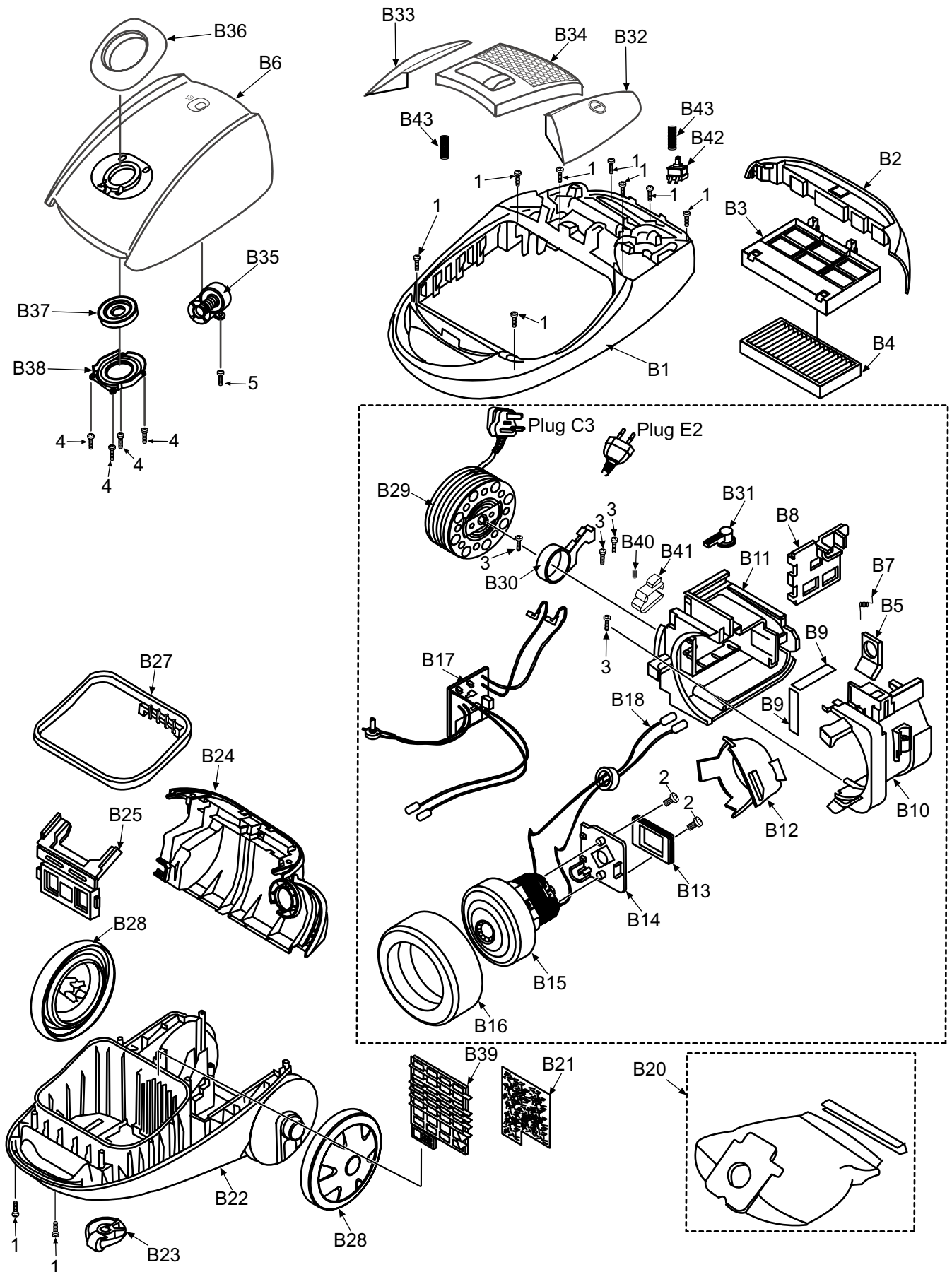

6.2. Attachment Exploded View

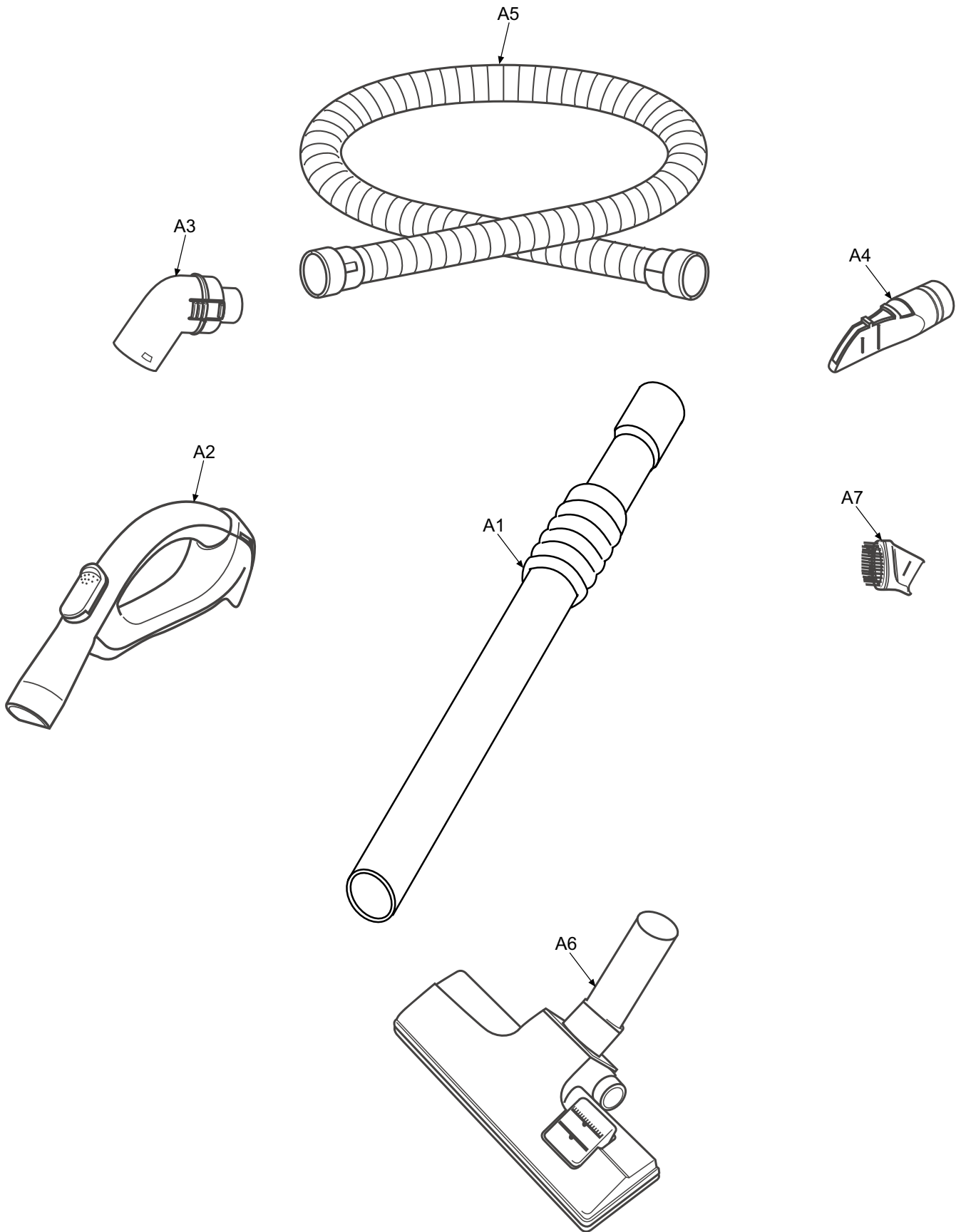

6.3. Packing Instruction

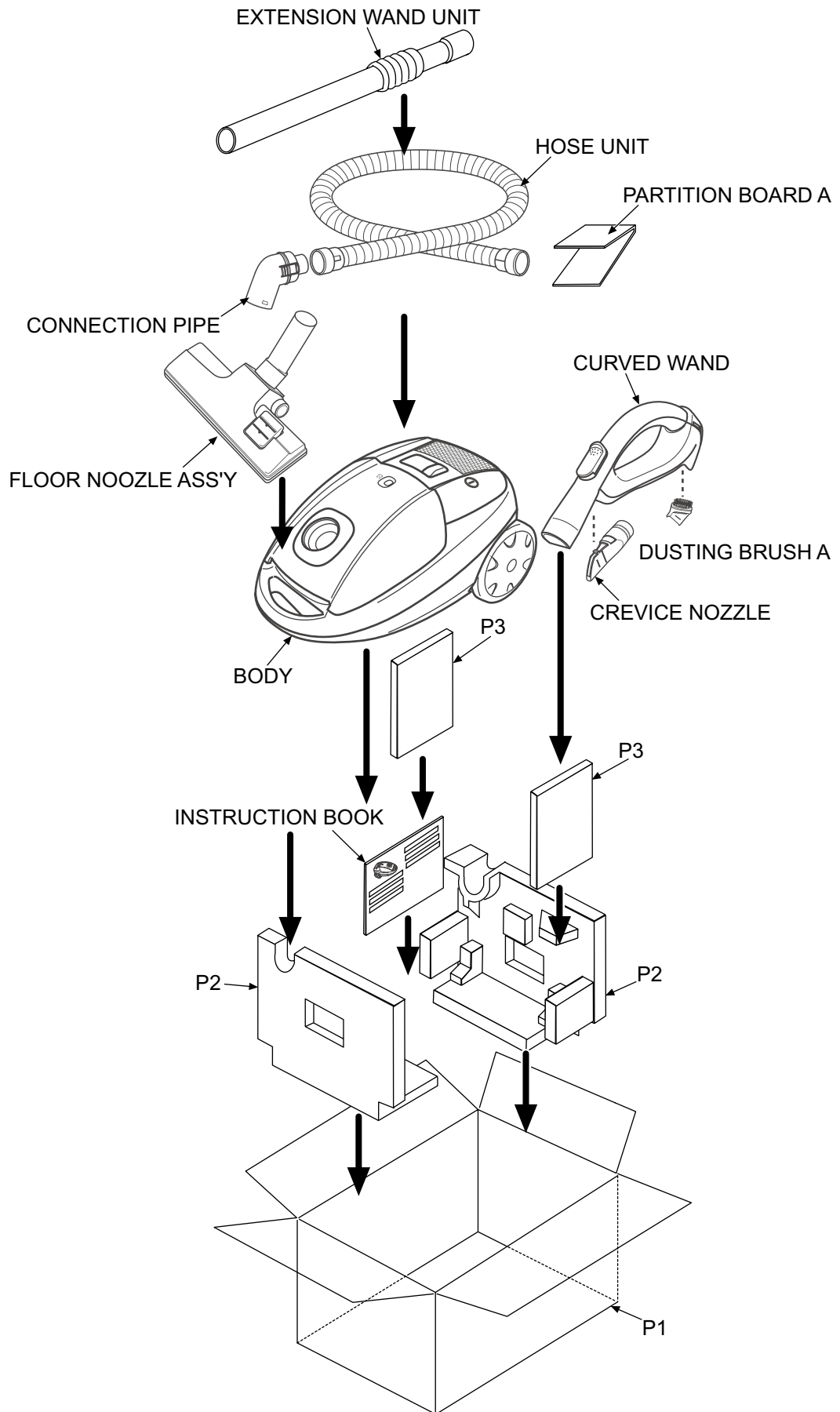

6.4. Replacement Parts List

Safety	Ref. No.	Part No.	Part Name & Description	Qty	Remarks
	1	XTN4+20BFJ	PAN TAP SCREW	10	
	2	XTN4+10FFJ	SCREW	2	
	3	XTN4+14BFJ	TAPPING SCREW	4	
	4	XTN4+12BFJ	PAN TAP SCREW	4	
	5	XTN4+12BFJ	PAN TAP SCREW	1	
	B1	YMV02ABW000	UPPER BODY	1	
	B2	YMV32KBW000	FILTER SUPPORTER	1	
	B3	YMV42KBW000	FILTER CASE	1	
	B4	YMV95KBW000	FILTER ASS'Y	1	
	B5	YMV96LBW000	BLOWER OUTLET UNIT	1	
	B6	YMV93KBX0K0	DUST COVER UNIT	1	BLACK
	B6	YMV93KBX0W0	DUST COVER UNIT	1	WHITE
	B7	YMV33LBW000	BLOWER COVER SPRING	1	
	B8	YMV59VBW000	PCB HOLDER	1	
	B9	YMV23EBW000	INSULATION PLATE	2	
	B10	YMV63FBW000	MOTOR SUPPORT COVER	1	
	B11	YMV09FBW000	MOTOR CASE	1	
	B12	YMV99GBX000	NOISE SUPPRESSOR UNIT	1	
	B13	YMV02FBX000	MOTOR SUPPORT RUBBER FRONT	1	
	B14	YMV07FCH000	MOTOR SUPPORT FRONT	1	
△	B15	YMV92FB600C	MOTOR FAN UNIT	1	
	B16	YMV03FBW000	MOTOR SUPPORT RUBBER REAR	1	
△	B17	YMV89VB6000	PCB A UNIT	1	
△	B18	YMV69VBX000	LEAD WIRE C UNIT	1	
	B20	YMC99KXQ000	CLOTH BAG UNIT	1	
	B21	YMV37KBW000	SECONDARY FILTER	1	
	B22	YMV03ABW000	LOWER BODY	1	
	B23	YMC95C7K100	CASTER UNIT	1	
	B24	YMV01LBW000	REAR COVER	1	
	B25	YMV23KBW000	SUPPORTER	1	
	B27	YMV73KBW000	DUST BOX PACKING	1	
	B28	YMV01CBX000	WHEEL	2	
△	B29	YMV99NBW000	CORD REEL UNIT	1	C3 PLUG
△	B29	YMV99NBW00Q	CORD REEL UNIT	1	E2 PLUG
△	B30	YMV98NBW000	RAIL BASE UNIT	1	
	B31	YMV25QBW000	SWIVEL CAP	1	
	B32	YMV05EBW000	SWITCH PEDAL	1	
	B33	YMV46NBW000	CORD REWIND BUTTON	1	
	B34	YMV02GBW000	BODY LINING UPPER	1	
	B35	YMV99MBW000	INDICATOR PIPE UNIT	1	
	B36	YMV63HBW000	FRONT MARK	1	
	B37	YMV64HBW000	SUCTION INLET PACKING	1	
	B38	YMV25KBW000	DUST BOX PLATE	1	
	B39	YMV43KBW000	PRE FILTER	1	
	B41	YMV43NBW000	BRAKE LEVER	1	
△	B42	YMV01E7B000	ON / OFF SWITCH	1	
	B43	YMV871NBW000	SPRING BRAKE BUTTON	2	
	A1	YMV99PBW000	METAL WAND TELESCOPIC	1	
	A2	YMV98PBW000	CURVE WAND UNIT	1	
	A3	YMV27HBW000	CONNECTION WAND	1	
	A4	YMV60R9L080	CREVICE NOZZLE	1	
	A5	YMC84PXP000	HOSE UNIT	1	
	A6	YMC99RXQ000	FLOOR NOZZLE ASS'Y	1	
	A7	YMC88RYX080	DUSTING BRUSH UNIT	1	
	P1	YMV61ZBX000	INDIVIDUAL CARTON	1	
	P2	YMV98ZBW000	CUSHION UNIT	1	
	P3	YMV46ZBW000	PARTITION BOARD	2	
△		YMV01ZBW000	INSTRUCTION BOOK	1	

