

Service Manual

Vacuum Cleaner
MC-9050/MC-9060/MC-9070

SUPPLEMENT



Please use this Manual together with Service Manual model MC-9026/MC-9028 Order No. MELCOM 9204-78, MC-9027/MC-9029 Order No. MELCOM 9510-93 and MC-9030 Order No. MELCOM 9808-303

SPECIFICATIONS

Model	MC-9050	MC-9060	MC-9070
Power Source	AC127V, AC220V~240V		AC220V~240V
Frequency (Hz)	50/60Hz		
Motor Power	1400W	1500W	1600W
Dust Capacity	15.0 litres	17.0 litres	20.0 litres
Dimensions (H x W x L)	514mm x 340mm x 366mm	544mm x 340mm x 366mm	584mm x 340mm x 366mm
Weight (With Attachment)	6.9kg	7.5kg	7.6kg
Cord Length	8.0m		
Attachments	Hose, Extension Wand, Floor Nozzle Extension Wand Holder Crevice Tool Upholstery Nozzle		

* Specifications are subject to change without notice for further improvement.

⚠ WARNING

This service information is designed for experienced repair technicians only and is not designed for use by the general public. It does not contain warnings or cautions to advise non-technical individuals of potential dangers in attempting to service a product. Products powered by electricity should be serviced or repaired only by experienced professional technicians. Any attempt to service or repair the product or products dealt with in this service information by anyone else could result in serious injury or death.

Panasonic

© 2004 Matsushita Electric Co., (M) Bhd. All rights reserved. Unauthorized copying and distribution is a violation of law. (Company No. 6100K)

PICTORIAL DIAGRAM

AC220V 50/60Hz, AC240V 50Hz
 WITH CAPACITOR AND FUSE
 MODEL : MC-9050/MC-9060/MC-9070
 CORD : A-2, C-2

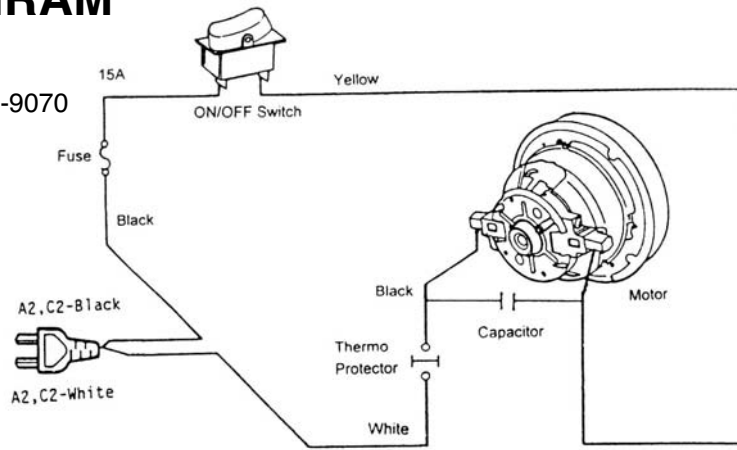

SCHEMATIC DIAGRAM

AC220V 50/60Hz, AC240V 50Hz
 WITH CAPACITOR AND FUSE
 MODEL : MC-9050/MC-9060/MC-9070
 CORD : A-2, C-2

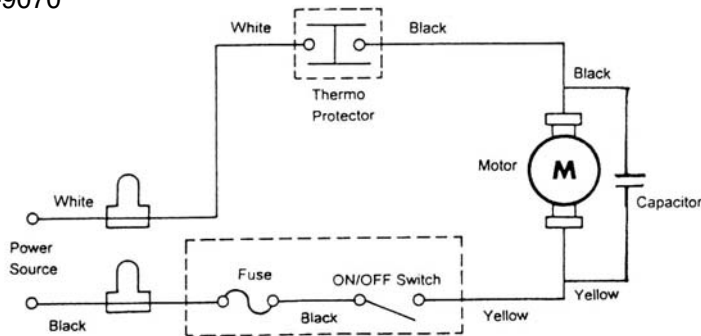

PICTORIAL DIAGRAM

AC220V 50/60Hz, AC240V 50Hz
 WITH CAPACITOR
 MODEL : MC-9050/MC-9060/MC-9070
 CORD : C-3

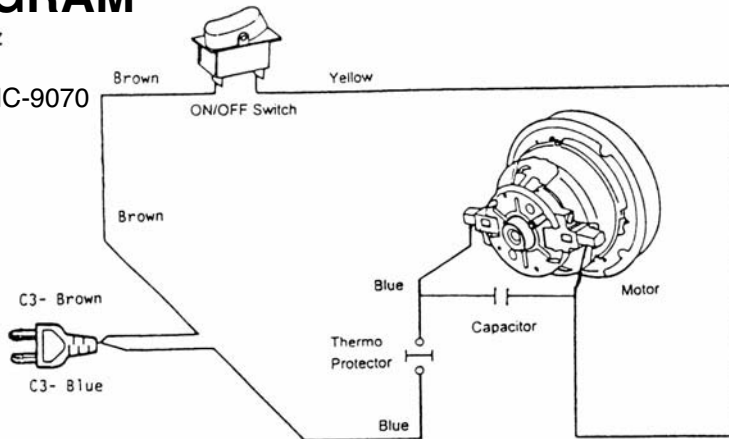

SCHEMATIC DIAGRAM

AC220V 50/60Hz, AC240V 50Hz
 WITH CAPACITOR
 MODEL : MC-9050/MC-9060/MC-9070
 CORD : C-3

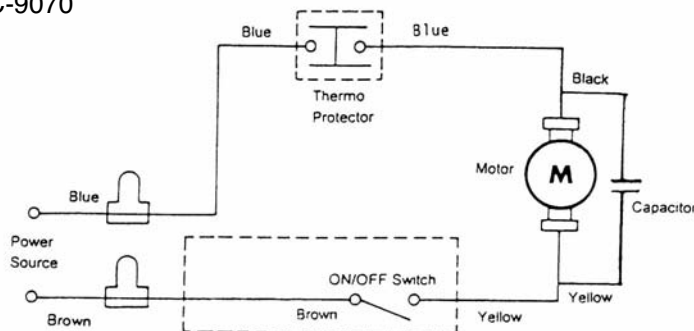

EXPLODED VIEW

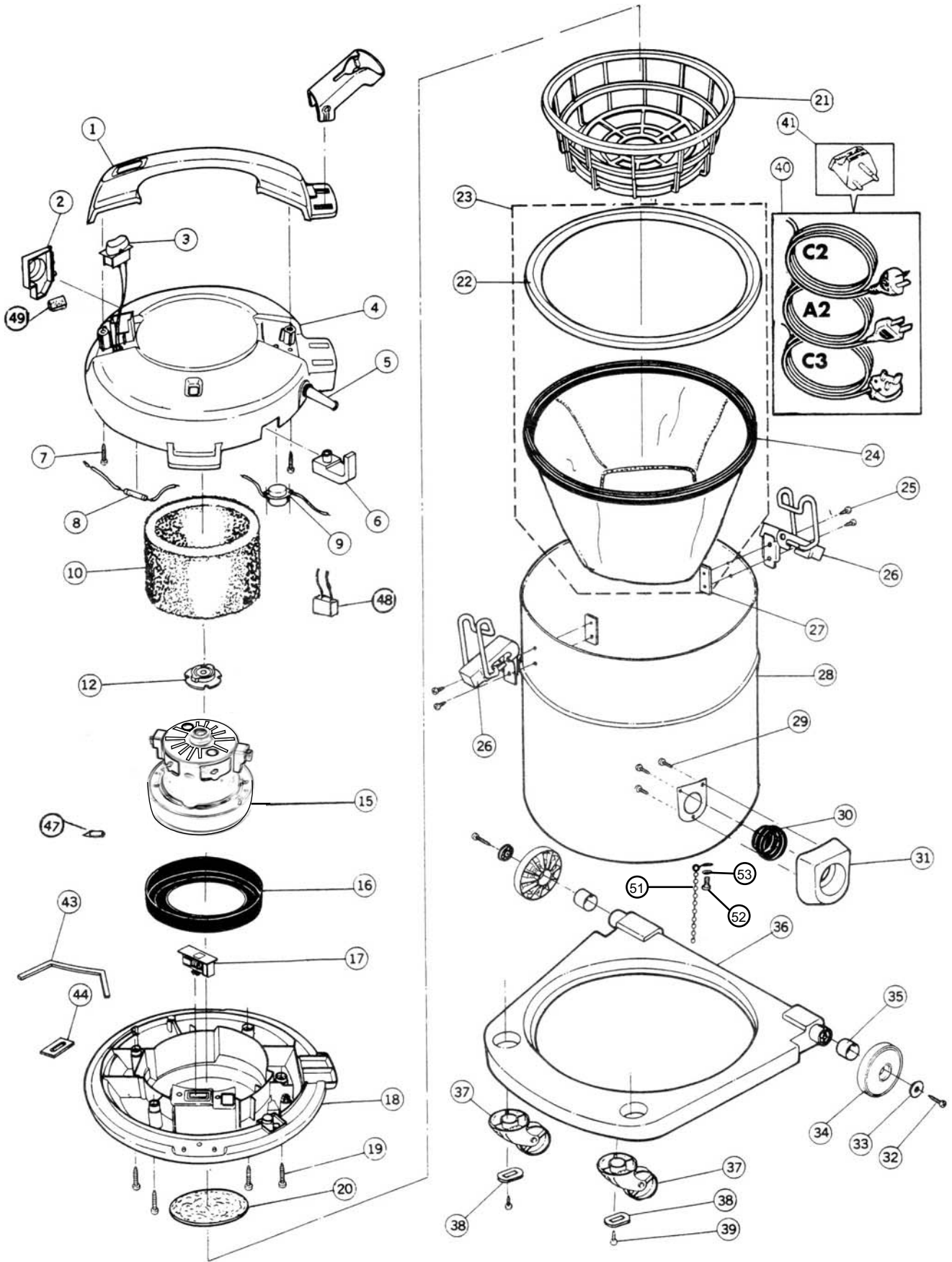

REPLACEMENT PART LIST

REF. NO.	PART NAME	PART NO.	MODEL(PCS/SET)			
			MC-9050	MC-9060	MC-9070	
1	Handle	AMC01BDE0G0	1	-	-	GREEN
(1)	Handle	AMC01BDE0R0	-	1	-	Red
(1)	Handle	AMC01BDE2L0	-	-	1	Brown
2	Blower Outlet Unit	AMC96LDD0V0	1	1	1	Dark Grey
3	Main Switch Unit	YMC98EVH00B	1	1	1	
(3)	Main Switch Unit	YMC98EVH000	1	1		for A2 SAUDI ARABIA 127V Country ONLY
4	Body Cover Unit	YMC24AVF000	1	-	-	GREEN
4	Body Cover Unit	YMC24AVG000	-	1	-	Red
(4)	Body Cover Unit	YMC24AVH000	-	-	1	Brown
5	Cord Bushing	AMC51EBY000	1	1	1	
6	Cord Storage Hook	AMC53EJJ0G0	1	-	-	Blue
(6)	Cord Storage Hook	AMC53EJJ0R0	-	1	-	Red
(6)	Cord Storage Hook	AMC53EJJ0L0		-	1	Brown
7	Truss Tap Screw	XTT4 + 20BFY	2	2	2	
8	Fuse Assembly (12A)	YMC97WVH00B	1	1	1	For 220V-240V GENERAL VERSION
(8)	Fuse Assembly (15A)	YMC97WVH00A	1	1	-	for A2 SAUDI ARABIA 127V Country ONLY
9	Thermo Protector Unit	YMC98WVH000	1	1	1	
10	Noise Suppressor Unit	AMC99GMW100	1	1	1	
12	Rear Motor Supporter	YMC03FSG000	1	1	1	
15	Motor Unit	YMC92FTW004	1	1	-	AC127V
(15)	Motor Unit	YMC92FTX00C	1	-	-	AC220V~240V
(15)	Motor Unit	YMC92FRT00C	-	1	-	AC220V~240V
16	Front Motor Support	AMC02F-SE000	1	1	1	
17	Indicator Unit	YMC99MVF000	1	-	-	
(17)	Indicator Unit	YMC99MVH000	-	1	1	(Except mc-9060 127V S.Arabia 1)
18	Upper Body Unit	AMC02ASE000	1	1	1	Black
19	Pan Head Recess Screw	XTN4+25FFY	4	4	4	
20	Filter	AMC30KVH000	1	1	1	
21	Expander	AMC18KDD000	1	1	1	
22	Bag Supporter	AMC10KC9000	1	1	1	
23	Filter Unit	AMC95KDD000	1	1	1	
24	Cloth Bag Unit	AMC99KDD000	1	1	1	
25	Pan Head Recess Screw	XYN4 + C6FYS	4	4	4	
26	Buckle Unit	AMC99DJJ000	2	2	2	
27	Buckle Plate	AMC32DB3000	2	2	2	
28	Lower Body	YMC03AVF000	1	-	-	15 litres - Green
(28)	Lower Body	YMC03AVG000	-	1	-	17 litres - Red
(28)	Lower Body	YMC03AVH000	-	-	1	20 litres - Brown
29	Truss Tapping Screw	XTT35 + 16BFY	2	2	2	
30	Air Valve Grommet	AMC50KJ3000	1	1	1	
31	Front Cover	AMC01HDD0K0	1	1	1	Black
32	Pan Tapping Screw	XTN4 + 16BFY	2	2	2	
33	Wheel Cap	AMC05CL90V0	2	2	2	
34	Wheel	AMC01C940V0	2	2	2	
35	Wheel Supporter	AMC02C97000	2	2	2	
36	Frame	AMC43A0E0V0	1	1	1	
37	Caster Unit	AMC95C0E000	2	2	2	
38	Washer	AMC26CB000	2	2	2	
39	Pan Tapping Screw	XTN4 + 16BFY	2	2	2	
40	Power Cord W/Plug (C-3)	YMC93ESE10H	1	1	1	H.Kong ONLY(1.00 mm ²)
(40)	Power Cord W/Plug (C-3)	YMC93EVH00A	1	1	1	(1.00 mm ²)
40	Power Cord W/Plug (C-3)	YMC93ESD00A	1	1	1	(0.75mm ²)
(40)	Power Cord W/Plug (A-2)	YMC97EVG004	1	1	-	S.Arabia 127V (1.8mm ²)
(40)	Power Cord W/Plug (A-2)	AMC97ENS00B	1	1	1	Thailand,Philippines
(40)	Power Cord W/Plug (C-2)	YMC96EVH000	1			(1.00 mm ²)
(40)	Power Cord W/Plug (C-2)	YMC96EVF000		1	1	(0.75 mm ²)
41	Plug Adapter C2/B2	AMC16W-8300B	1	1	1	
43	Tight Packing	AMC81ADD000	1	1	1	
44	Indicator Packing	AMC09MDD000	1	1	1	
(45)	Exhaust Packing Unit	YMC85LVH100	1	1	1	
47	Fasten Connector	TANS148520	2	2	2	
48	Capacitor	YMC46FMW00E	1	1	1	
49	Exhaust Packing	AMC60LNS000	1	1	1	
50	Motor Case Rubber	YMC14FTX100	1	1	1	
51	Grounding Chain	YMC56HQN000	1	1	1	
52	Screw Washer	XTT3+8FFY	1	1	1	
53	Nut	XNF3EFYS	1	1	1	
54	Washer	YMC09USL000	1	1	1	

ATTACHMENT PART LIST

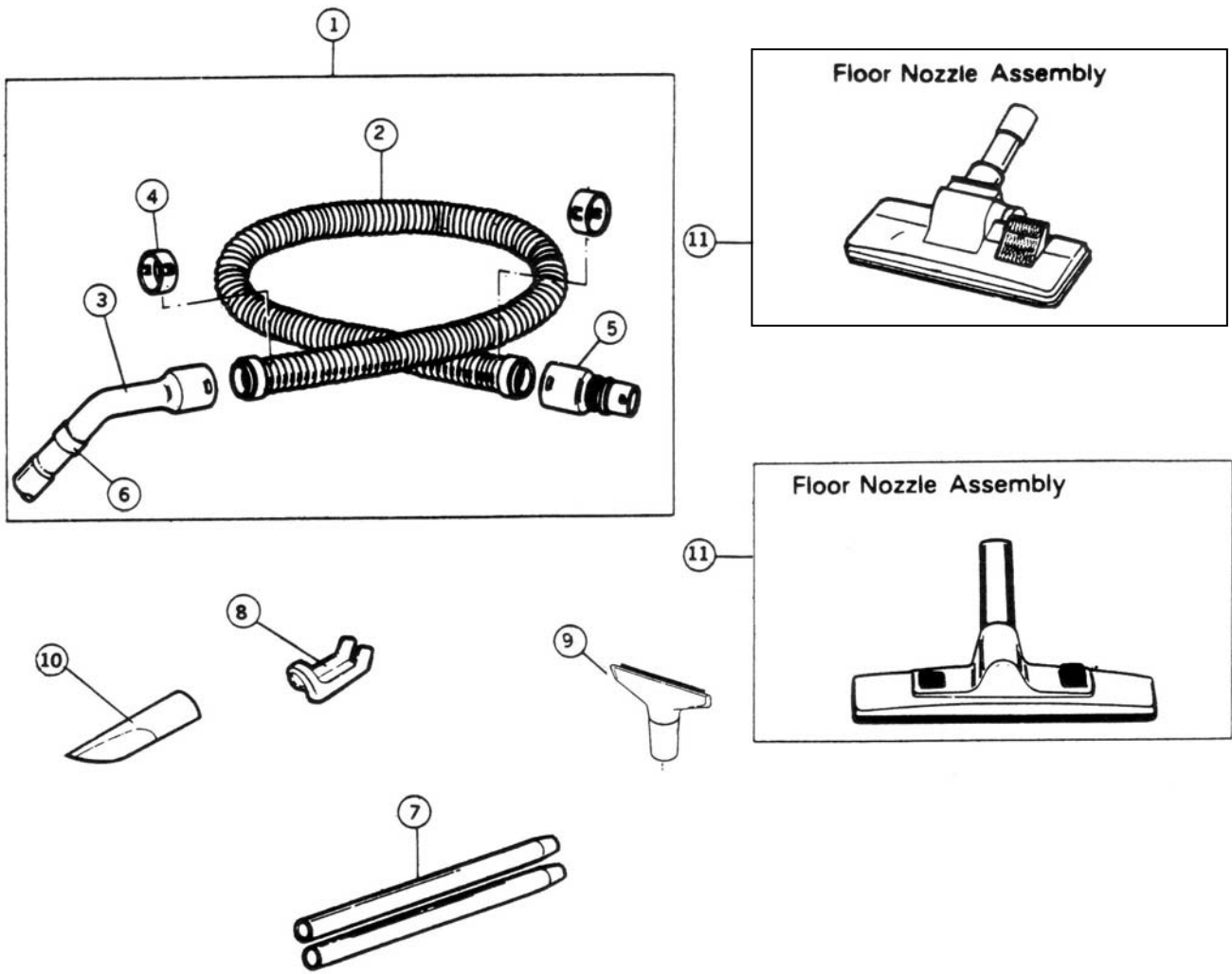

EXPLODE VIEW (ATTACHMENT)

REF. NO.	PART NAME	PART NO.	MODEL (PCS/SET)			REMARKS
			MC-9050	MC-9060	MC-9070	
1	Hose Unit	AMC94PDD0V0	1	1	1	
2	Hose	AMC01PDD0V0	1	1	1	
3	Curved Wand	AMC30P0R1V0	-	-	-	
(3)	Curved Wand	YMC98PDE0V0	1	1	1	Antistatic
4	Hose Supporter	AMC24P-0R0V0	2	2	2	
5	Connection Pipe	AMC02P-0R0V0	1	1	1	
6	Suction Regulator	AMC54P7K000	1	1	1	
7	Extension Wand	AMC40P-B12V0	-	-	-	Plastic
(7)	Extension Wand	YMC40PQW000	2	2	2	Metal
8	Extension Wand Holder	AMC70P-K200	1	1	1	
9	Upholstery Nozzle Unit	AMC62R860VA	1	1	1	
10	Crevice Tool	YMC60R0G2V0	1	1	1	
11	Floor Nozzle Ass'y	AMC99RRS000	-	1	1	
(11)	Floor Nozzle Ass'y	AMC99R6L000	1	-	-	

TROUBLESHOOTING

Problem	Check
Motor does not operate.	<ul style="list-style-type: none"> ● Is the plug fully plugged into the wall socket?
Suction power is weak.	<ul style="list-style-type: none"> ● Thoroughly wash the filter. ● Is the cover of the vacuum cleaner firmly closed?
The motor turns off during vacuuming.	<ul style="list-style-type: none"> ● A safety device is operating. <ol style="list-style-type: none"> ① Remove the refuse caught in the nozzle or hose. ② Wait approximately 5 to 25 minutes. The safety device will release and you can then resume operations.

MAINTAINING OUR VACUUM CLEANER



Warning

■ Before maintaining
 Turn off the on/off switch and unplug the power cord.

 May cause an electrical shock or injury

- NOTE**
- Dry filters completely in the air.
 - Do not bend, pull, and step on the hose or put anything heavy on it.

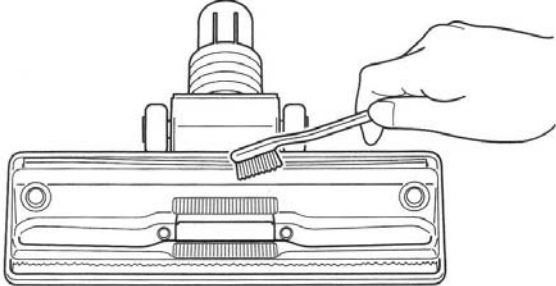
Floor nozzle



Remove refuse with the brush.

Vacuum cleaner body and accessories



Wipe with a soft cloth soaked with water.

MAINTAINING THE FILTER

1

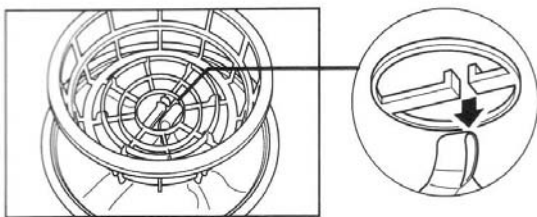

Remove the expander from the filter as illustrated.

2

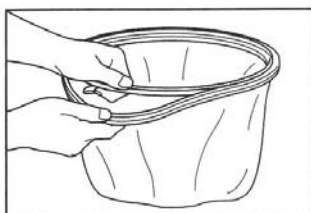

Dismount the filter while holding the filter frame.

3

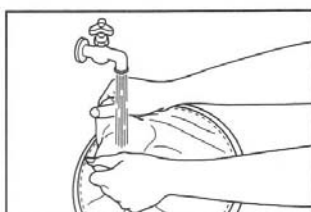

Wash the filter in water by hand. (Do not use washer or dryer.)

4

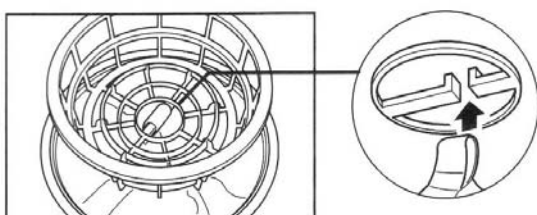

When filter becomes completely dry, replace it as in the same manner in reverse.

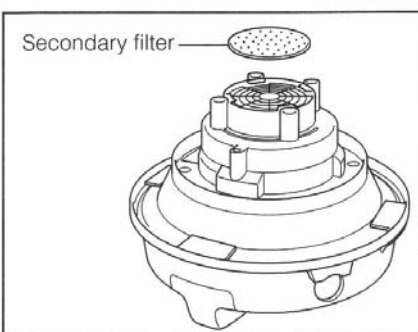

■ When secondary filter becomes dirty

⇒ Rinse it with water and dry completely before reusing.

REMOVING THE FILTER

■ If the vac gauge turns red, discard the dust.

1

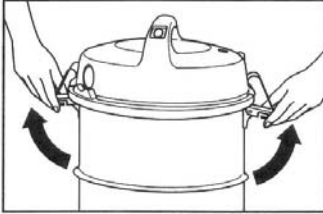

Pull the clamps upward,

2

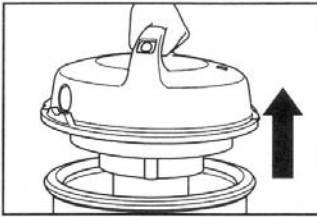

Remove the motor housing hanging upward with the carrying handle.

3

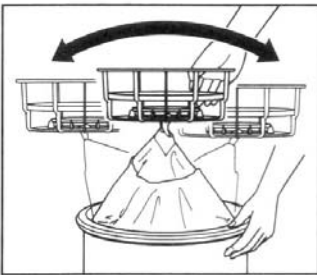

Pull the expander upward and shake it about ten times.
(Never shake up and down. / Leave the hose connected.)

4

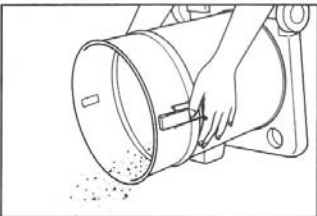

Remove the Filter and empty dirt and dust.

PACKING INSTRUCTION

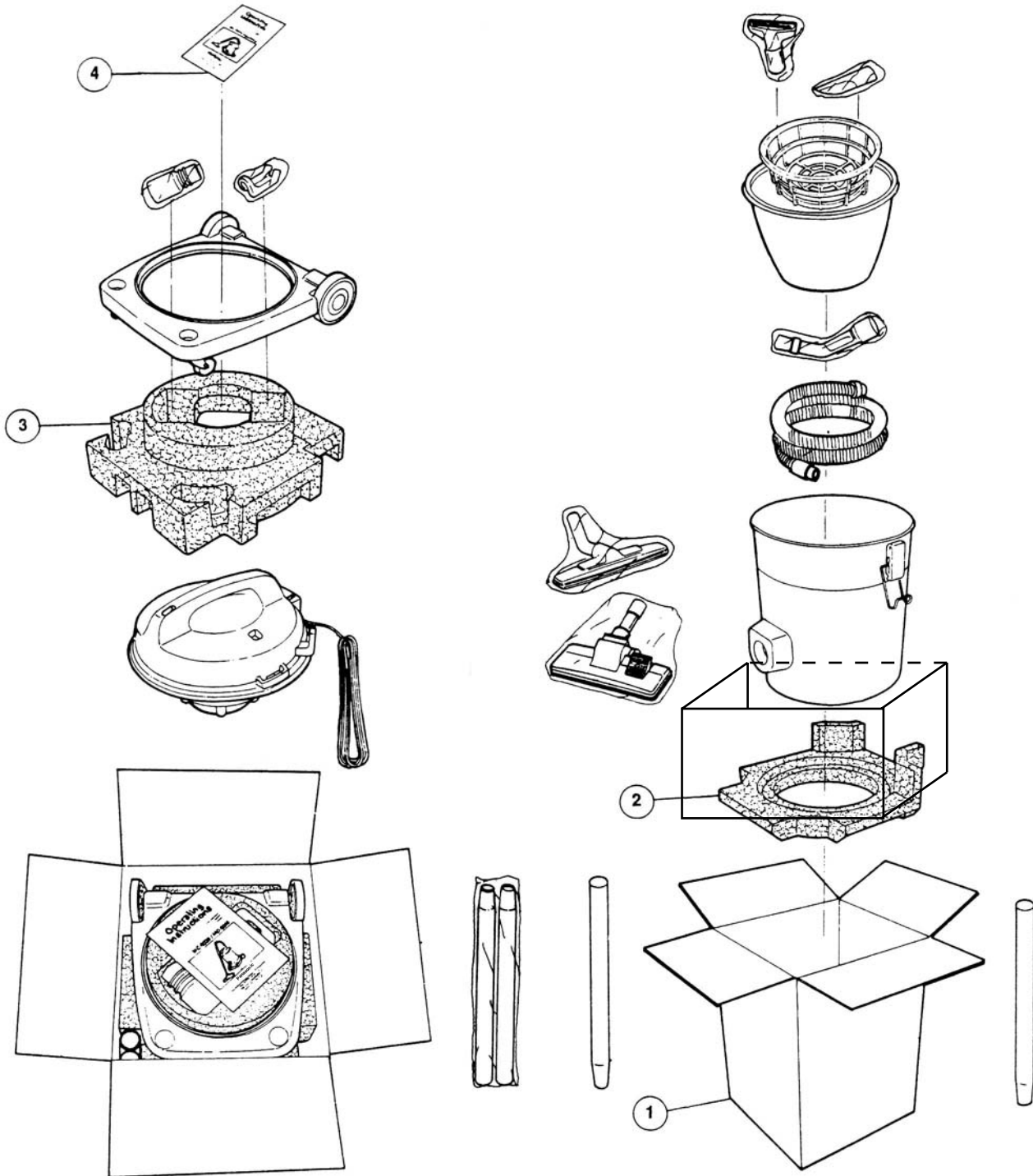

PACKING LIST

REF. NO.	PART NAME	PART NO.	MODEL (PCS/SET)			REMARKS
			MC-9050	MC-9060	MC-9070	
1	Individual Carton	YMC61ZVF000	1	-	-	
(1)	Individual Carton	YMC61ZVG000	-	-	1	
(1)	Individual Carton	YMC61ZVH00X	-	-	1	Egypt
(1)	Individual Carton	YMC61ZVH000	-	-	1	
2	Cushion C	AMC69ZVH100	1	1	1	
2	Cushion B	AMC70ZSE000	1	1	1	
5	Cushion A	AMC69ZSE000	1	1	1	
6	Instruction Book	YMC01ZHV000	1	1	1	General