

Service Manual

Refrigerator

NR-BY552XS
NR-BY552XW
NR-BY602XS



NR-BY552XS, XW

NR-BY602XS

Product Colour

Stainless Touch (XS)
Korean White (XW)

Destination

Thailand, Malaysia, Singapore
Indonesia, Vietnam, India
Philippines, GULF, PGF
Australia/New Zealand



CFCs have been used in refrigerant as refrigerator and the insulation materials for many years. But it is now known that these compounds which once seemed so ideal for use as cleaning agents and in refrigeration systems, destroy the earth's ozone layer as a result, an international body decided on a total worldwide ban of harmful CFCs by the end of 1995.

⚠ WARNING

The service information is designed for experienced repair technicians only and is not designed for use by the general public. It does not contain warnings or cautions to advise non-technical individuals of potential dangers in attempting to service a product. Products powered by electricity should be serviced or repaired only by experienced professional technicians. Any attempt to service or repair the product or products dealt within this service information by anyone else could result in serious injury or death.

IMPORTANT SAFETY NOTICE

There are special components used in this equipment which are important for safety. These parts are marked by **⚠** in the Schematic Diagrams, Circuit Board Diagrams, Exploded Views and Replacement Parts List. It is essential that these critical parts should be replaced with manufacturer's specified parts to prevent shock, fire or other hazards. Do not modify the original design without permission of manufacturer.







CONTENT

	Page
1. Safety Cautions for Repairing	3
1.1 Warning	
1.2 Caution	
2. Specification and Components	
2.1 NR-BY552XS, XW	4
2.2 NR-BY602XS	5
3. Performance Data	6
3.1 NR-BY552X (AT 32 ± 1°C)	
3.2 NR-BY602X (AT 32 ± 1°C)	
4. Display Specification	7
5. Self Protecting Function	
5.1 Protecting for IC	8
5.2 Protection for compressor locked	9
5.3 Protection for power supply dropping	10
6. Self Diagnosing Function	11
7. Temperature Control	12
8. Inverter Control Display	13
9. Refrigerator Instruction Guideline	14
10. Troubleshooting Guide	
10.1 Not cool at all [Both PC & FC (compressor does not operate)]	15
10.2 Cool, not enough [Both PC & FC (compressor operates)]	16 - 17
10.3 Eco-Navi operation doesn't work (PC/FC/IC cooling condition is normal)	18
11. Schematic Diagram	
11.1 Wiring Diagram : NR-BY552XS, XW	19
11.2 Wiring Diagram : NR-BY602XS	20
12. Disassembly Instruction	
12.1 LCD Cover	21
12.2 Cover Control	22
12.3 PCB Control	22
12.4 Feature of Crisper	23
12.5 Maintain method : Take off Crisper handle	23 - 24
12.6 Maintain method : Crisper handle ass'y	24 - 25
13. Parts Exploded View and Replacement Parts List	
13.1 Part Exploded View : Body	26
13.2 Part Exploded View : Door	27
13.3 Part Exploded View : Packing	28
13.4 Replacement Parts List : NR-BY552XS, XW / NR-BY602XS	29 - 31
Detail Change Notice	32







1. SAFETY CAUTIONS FOR REPAIRING

When you repair the refrigerator, please kindly take care for the following cautions.

1.1 Warning

	<p>Before repairing unit, unplug supply cord</p> <ul style="list-style-type: none"> • Before you repair the refrigerator, please unplug the supply cord.
	<p>Use authentic parts when repairing</p> <ul style="list-style-type: none"> • When you replace the parts, please use authentic parts to replace defective parts.
	<p>Caution during brazing</p> <ul style="list-style-type: none"> • When you use touch for brazing, please ensure ventilation. Otherwise, you will be poisoned by carbon monoxide.
	<p>Pay attention to using refrigerant</p> <ul style="list-style-type: none"> • If refrigerant touches fire, the gas becomes poisonous gas.
	<p>Pay attention to getting electricity shock</p> <ul style="list-style-type: none"> • When you check the voltage of terminal, please do not touch the electricity part terminal. • When you replace the parts, please wait for 3 minutes at least for discharging capacitor.
	<p>Check safety after repairing</p> <ul style="list-style-type: none"> • Check the screws, parts, lead wires to take in place. • Check the repairing portion whether circumferential parts are damaged or not. • Check insulation resistance between supply plug and earth. • When install refrigerator, check condition of supply cord and plug. • Wipe off the dust on plug. • Cutting and seal the electric device carefully.

1.2 Caution

	<p>Watch the hot parts</p> <ul style="list-style-type: none"> • During operation and after operation, compressor and pipes are hot. • Also, under these condition, heater are hot. • Do not burn your fingers when you touch it.
	<p>Pay attention to refrigerant</p> <ul style="list-style-type: none"> • Do not touch liquid refrigerant. Otherwise your hands may be burnt.
	<p>Pay attention to edge of parts</p> <ul style="list-style-type: none"> • Otherwise, your fingers may be cut.
	<p>Pay attention to fins of evaporator and condenser</p> <ul style="list-style-type: none"> • Otherwise, your fingers may be cut.
	<p>Before transportatin, adjust the bolt</p> <ul style="list-style-type: none"> • Otherwise, the floor may be damaged.
	<p>Do not touch the pipe after brazing</p> <ul style="list-style-type: none"> • Otherwise, your hands may be burnt.

2. SPECIFICATION AND COMPONENTS

2.1 NR-BY552XS, NR-BY552XW

MODEL	NR-BY552XS								NR-BY552XW
Destination	Thailand	Malaysia	Singapore	Indonesia	Vietnam	India	Philippines	Australia/New Zealand	Australia/New Zealand
Code Attached Model	TH	MY	SG	1D	VN	1N	PH	AU/NZ	AU/NZ
Material Spec.	Stainless								White
System Spec.	Inverter								
Plug	C3P	S3P	S3P	C2P	C2P	B3P	A2P	K3P	K3P
Power Source	220V/50Hz	240V/50Hz	230V/50Hz	220-240V/50Hz	220V/50Hz	230V/50Hz	230V/60Hz	240V/50Hz	240V/50Hz

Specification

Capacity (Total Gross Volume)	551L (FC : 153L, PC : 398L)	
Capacity (Total Storage Volume)	461L (FC : 99L, PC : 362L)	
External Dimension	Width (mm)	775
	Depth (mm)	745
	Height (mm)	1714
Temperature Control	FC : Electronic control (PCB) PC : Baffle damper thermostat	
Defrosting	Full-automatic heater defrost with Micro Controller	
Inner Liner	Vacuum Formed ABS resin	
Insulation	Polyurethane foam (cabinet and door)	
Net Weight	80 Kg	

Sealed Unit

Evaporator	Fin Tube Type	
Condenser	Wrapper Type (concealed condenser)	
Compressor	Model Name	EF1100E13DGH-CO ECS
	Cylinder Capa.	10.17 cm ³ / rev
	REF. Capa.	27 / 52r / s, 75 / 193W
	Power Input	40.5 / 112W
Dryer	Type	Molecular Sieves (XH-9)
	Charging Amt.	5g.
Refrigerant	Type	R600a
	Charging Amt.	65 ± 5g
Lubricating Oil	Type	Freol S -10
	Charging Amt.	215 ± 5ml

Electric Part

Door Switch	Type	D3D-121 (S.P. - S.T.)
	Rating	250V / 0.5A
Fan Motor	Type	FBA11J14VXA Ø 110mm. prop fan (Box Type)
	Rating	DC 14V / 1.54W
Defrosting Control / Electronic PCB Control	Type	PAS - BY602X (Control)
	Defrost Cycle	(1) Ambient Temp. over 34°C 8h
		(2) Ambient Temp. 23°C ~ 33°C 8h
		(3) Ambient Temp. under 22°C 13h
(4) Power on 4h (Rated time)		
Heating Device for Defrosting	Type	MM6-8V41
	Rating	230V / 216W
Overload Protector	Type	MM3-20DCW
	Opening Temp.	105 ± 5°C
	Closing Temp.	61 ± 8°C
	Impression I.	2.0 A ± 75% (AT 70°C)
Automatic Temp. Control Device (PC) (Baffle Damper)	Type	MM1-6187
	Rating	Closed Temp. (normal) -6.0 ± 1.5°C
	Kind	Gas Charge Type
Defrost Sensor (DFC)	Type	NTC
	Rating	B = 3819K ± 2%
		R10 = 3.899KΩ ± 3%
FC Sensor (FCC)	Type	NTC
	Rating	B = 3850K ± 2%
		R-20 = 18.9KΩ ± 1.8%
Ambient Temp. Sensor (ATC)	Type	NTC
	Rating	B = 3435 ± 1%
		R25 = 10.0KΩ ± 3%
Defrost Thermal Fuse	Type	Micro Temp.
	Rating	250V / 10A / 73°C
Light Irradiation Device (PC)	Type	LED Lamp PCB
	Rating	12V / 100mA
Light Irradiation Device (Crisper)	Type	LED Lamp PCB
	Rating	5V / 30mA

2.2 NR-BY602XS

MODEL	NR-BY602XS								
Destination	Thailand	Malaysia	Singapore	Indonesia	Vietnam	India	Philippines	GULF	PGF
Code Attached Model	TH	MY	SG	1D	VN	1N	PH	AE	WG
Material Spec.	Stainless								
System Spec.	Inverter								
Plug	C3P	S3P	S3P	C2P	C2P	B3P	A2P	S3P	C2P (Shuko)
Power Source	220V/50Hz	240V/50Hz	230V/50Hz	220-240V/50Hz	220V/50Hz	230V/50Hz	230V/60Hz	220V/50Hz	220V/50Hz

Specification

Capacity (Total Gross Volume)	602L (FC : 153L, PC : 449L)								
Capacity (Total Storage Volume)	511L (FC : 99L, PC : 412L)								
External Dimension	Width (mm)	775							
	Depth (mm)	745							
	Height (mm)	1846							
Temperature Control	FC : Electronic control (PCB) PC : Baffle damper thermostat								
Defrosting	Full-automatic heater defrost with Micro Controller								
Inner Liner	Vacuum Formed ABS resin								
Insulation	Polyurethane foam (cabinet and door)								
Net Weight	86 Kg								

Sealed Unit

Evaporator	Fin Tube Type								
Condenser	Wrapper Type (concealed condenser)								
Compressor	Model Name	EF1100E13DGH-COEC5							
	Cylinder Capa.	10.17 cm ³ / rev							
	REF. Capa.	27 / 52r / s, 75 / 193W							
	Power Input	40.5 / 112W							
Dryer	Type	Molecular Sieves (XH-9)							
	Charging Amt.	5g.							
Refrigerant	Type	R600a							
	Charging Amt.	65 ± 5g							
Lubricating Oil	Type	Freol S -10							
	Charging Amt.	215 ± 5ml							

Electric Part

Door Switch	Type	D3D-121 (S.P. - S.T.)							
	Rating	250V / 0.5A							
Fan Motor	Type	FBA11J14VXA Ø 110mm. prop fan (Box Type)							
	Rating	DC 14V / 1.54W							
Defrosting Control / Electronic PCB Control	Type	PAS - BY602X (Control)							
	Defrost Cycle	(1) Ambient Temp. over 34°C 8h							
		(2) Ambient Temp. 23°C ~ 33°C 8h							
		(3) Ambient Temp. under 22°C 13h							
(4) Power on 4h (Rated time)									
Heating Device for Defrosting	Type	MM6-8V41							
	Rating	230V / 214W							
Overload Protector	Type	MM3-20DCW							
	Opening Temp.	105 ± 5°C							
	Closing Temp.	61 ± 8°C							
	Impression I.	2.0 A ± 75% (AT 70°C)							
Automatic Temp. Control Device (PC) (Baffle Damper)	Type	MM1-6187							
	Rating	Closed Temp. (normal) -6.0 ± 1.5°C							
	Kind	Gas Charge Type							
Defrost Sensor (DFC)	Type	NTC							
	Rating	B = 3819K ± 2% R10 = 3.899KΩ ± 3%							
FC Sensor (FCC)	Type	NTC							
	Rating	B = 3850K ± 2% R-20 = 18.9KΩ ± 1.8%							
Ambient Temp. Sensor (ATC)	Type	NTC							
	Rating	B = 3435 ± 1% R25 = 10.0KΩ ± 3%							
Defrost Thermal Fuse	Type	Micro Temp.							
	Rating	250V / 10A / 73°C							
Light Irradiation Device (PC)	Type	LED Lamp PCB							
	Rating	12V / 100mA							
Light Irradiation Device (Crisper)	Type	LED Lamp PCB							
	Rating	5V / 30mA							

3. PERFORMANCE DATA

3.1 NR-BY552 (AT $32 \pm 1^\circ\text{C}$)

Thermostat Dial Setting		“ 3 ”	“ 2 ”	“ 1 ”
Mean Fresh Food Compartment Temp.	t3 (°C)	1.5 ± 2.5	4.0 ± 2.5	7.0 ± 2.5
Mean Freezer Load Temp.	(°C)	-22.0 ± 2.5	-20.0 ± 2.5	-15.0 ± 2.5
Vegetable Crisper Temp.	(°C)	-	4.0 ± 2.5	-
PC Door Shelf Upper Temp.	(°C)	-	7.0 ± 2.5	-
Egg Tray Temp.	(°C)	-	4.0 ± 2.5	-
PC Door Shelf Bottom Temp.	(°C)	-	5.0 ± 2.5	-
Chilled Case Temp.	(°C)	-	0.0 ± 2.5	-
Running Ratio	(%)	85 ± 15	80 ± 15	65 ± 15
Power Consumption	(KWh/Day)	-	2.2 or under	-

3.2 NR-BY602 (AT $32 \pm 1^\circ\text{C}$)

Thermostat Dial Setting		“ 3 ”	“ 2 ”	“ 1 ”
Mean Fresh Food Compartment Temp.	t3 (°C)	1.5 ± 2.5	4.0 ± 2.5	7.0 ± 2.5
Mean Freezer Load Temp.	(°C)	-22.0 ± 2.5	-19.5 ± 2.5	-15.0 ± 2.5
Vegetable Crisper Temp.	(°C)	-	5.0 ± 2.5	-
PC Door Shelf Upper Temp.	(°C)	-	8.0 ± 2.5	-
Egg Tray Temp.	(°C)	-	5.0 ± 2.5	-
PC Door Shelf Bottom Temp.	(°C)	-	5.5 ± 2.5	-
Chilled Case Temp.	(°C)	-	1.5 ± 2.5	-
Running Ratio	(%)	85 ± 15	80 ± 15	65 ± 15
Power Consumption	(KWh/Day)	-	2.2 or under	-

4. DISPLAY SPECIFICATION

■ NR-BY602

PROCESS INSPECTION		DISPLAY
IN-PROCESS INSPECTION		
START CONDITION		Operate the following controls within 3 sec., within 30 sec., after power-on while PC and FC door are open. QUICK FREEZING BUTTON → FREEZER CONTROL BUTTON → QUICK FREEZING BUTTON
END CONDITION		① Hold down QUICK FREEZING BUTTON for over a second. (Manual defrost) ② After 4 hours (Defrost start)
CONTENTS FOR CONTROL		COMP : R 6 (71rps) FC FAN : VF4 (Ultrahigh Speed) HEATER : DEFROST HEATER OFF LED : ECONAVI LED and FREEZER LED [NORMAL] BRINKING (ON_1sec/OFF_1sec)
MANUAL DEFROST		Hold down QUICK FREEZING BUTTON for over a sec.
AUTOGNOSIS		During in-process inspection.
JUDGEMENT		Indicate AUTOGNOSIS in which case abnormal condition.
NOISE MODE		For 45 sec., of the start of IN-PROCESS INSPECTION
CONTENTS		COMP : R 7 (80rps)
INSPECTION OF TEMP.		For 30 min., of the start of IN-PROCESS INSPECTION
JUDGEMENT		Normal or abnormality is displayed according to the range of drop of FCC ALL FREEZER LED LIGHTING.....GOOD ALL FREEZER LED BRINKING.....BAD
INSPECTION OF ILLUMINANCE SENSOR	1	During IN-PROCESS INSPECTION
JUDGEMENT		After 1 min., of the start of IN-PROCESS INSPECTION. Abnormality is judged according to variation width of input voltage of illuminance sensor. ECONAVI LED EXTINCTION.....GOOD ECONAVI LED LIGHTING.....BAD

Contents of discussion

- 1 Illuminance sensor will be added. Therefore, an inspection of whether to be able to operate normally is necessary.
 < In-process inspection of illuminance sensor >
- ① ECONAVI LED blinks at the start of in-process inspection → check whether ECONAVI LED blinks.
 - ② ECONAVI LED lights up after 1 min., of the start of in-process inspection (because if there is less input variation, microcomputer judge that as abnormal) → check whether ECONAVI LED lights up.
 - ③ Lighting of illuminance sensor shall be varied manually or automatically after the completion of aging. (If there is input variation corresponding to a dark area and a bright area, microcomputer judges that as normal)
 In Japan, a dark area and a bright area have been created in the place for inspection process.
 - ④ As long as the illuminance sensor is normal, ECONAVI LED goes out → check whether ECONAVI LED goes out.

5. SELF PROTECTING FUNCTION

5.1 Protection for IC

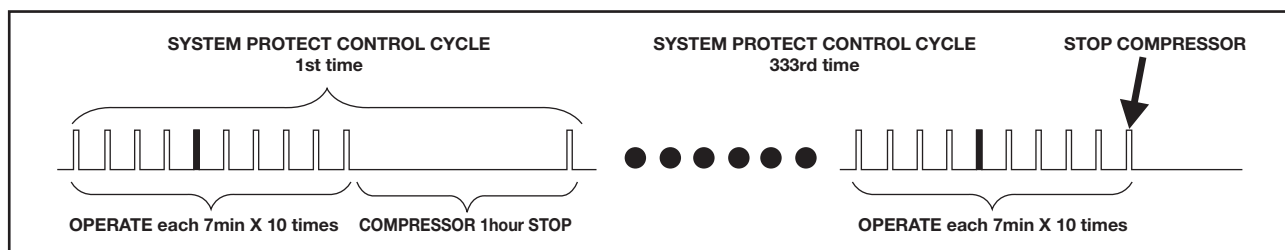
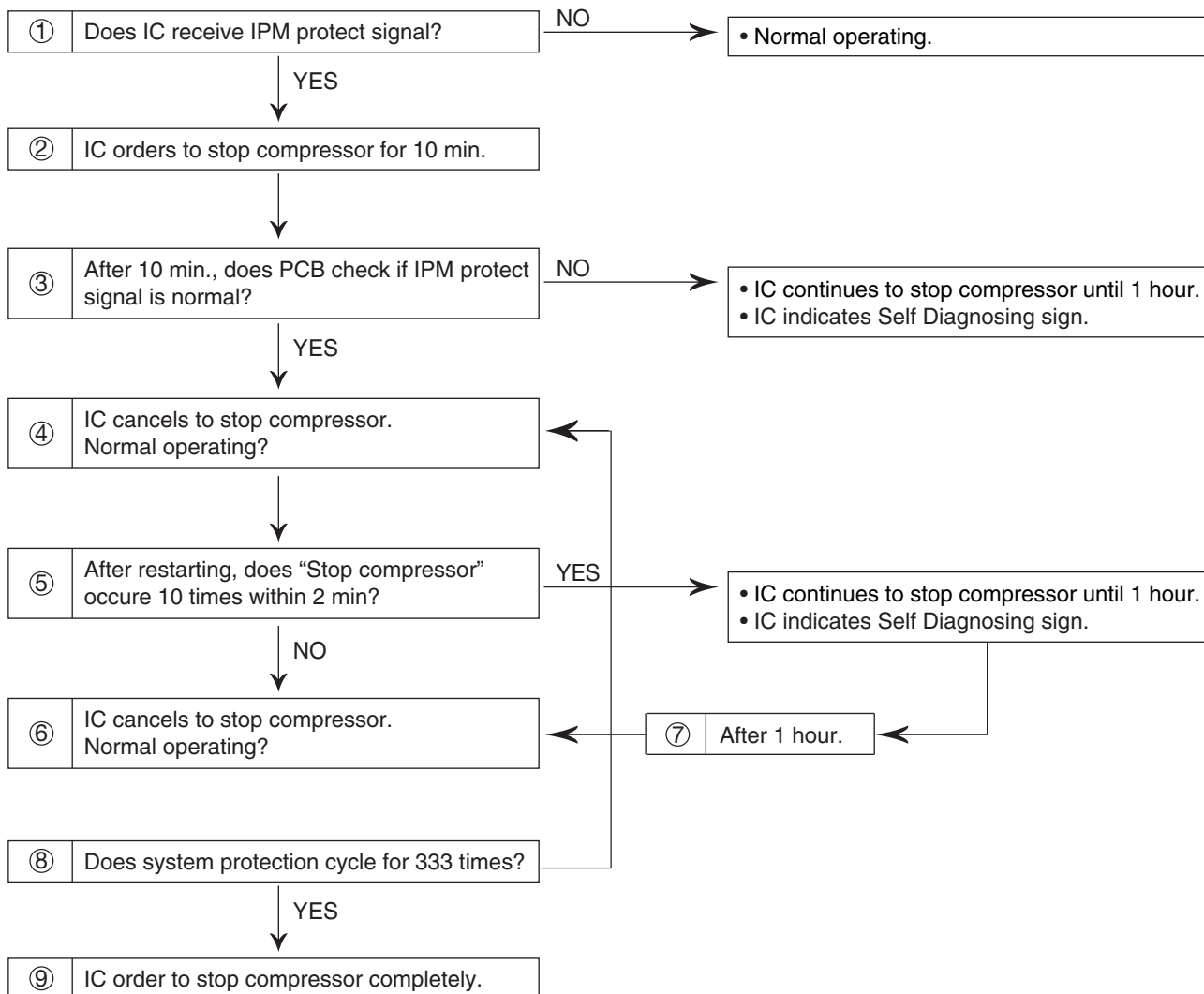

5.2 Protection for compressor locked

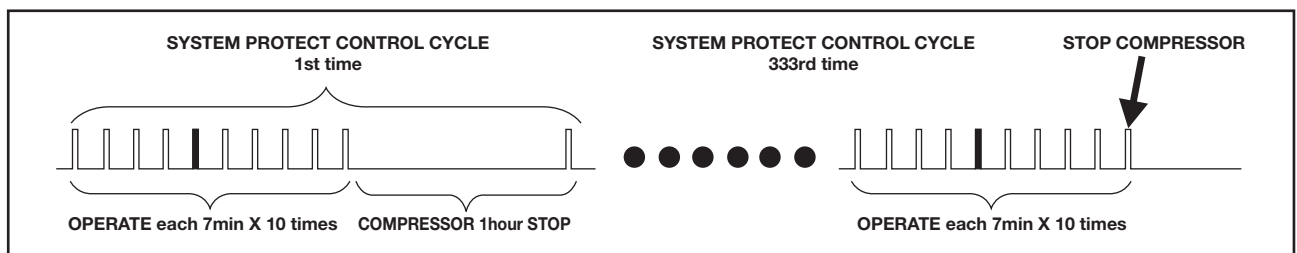
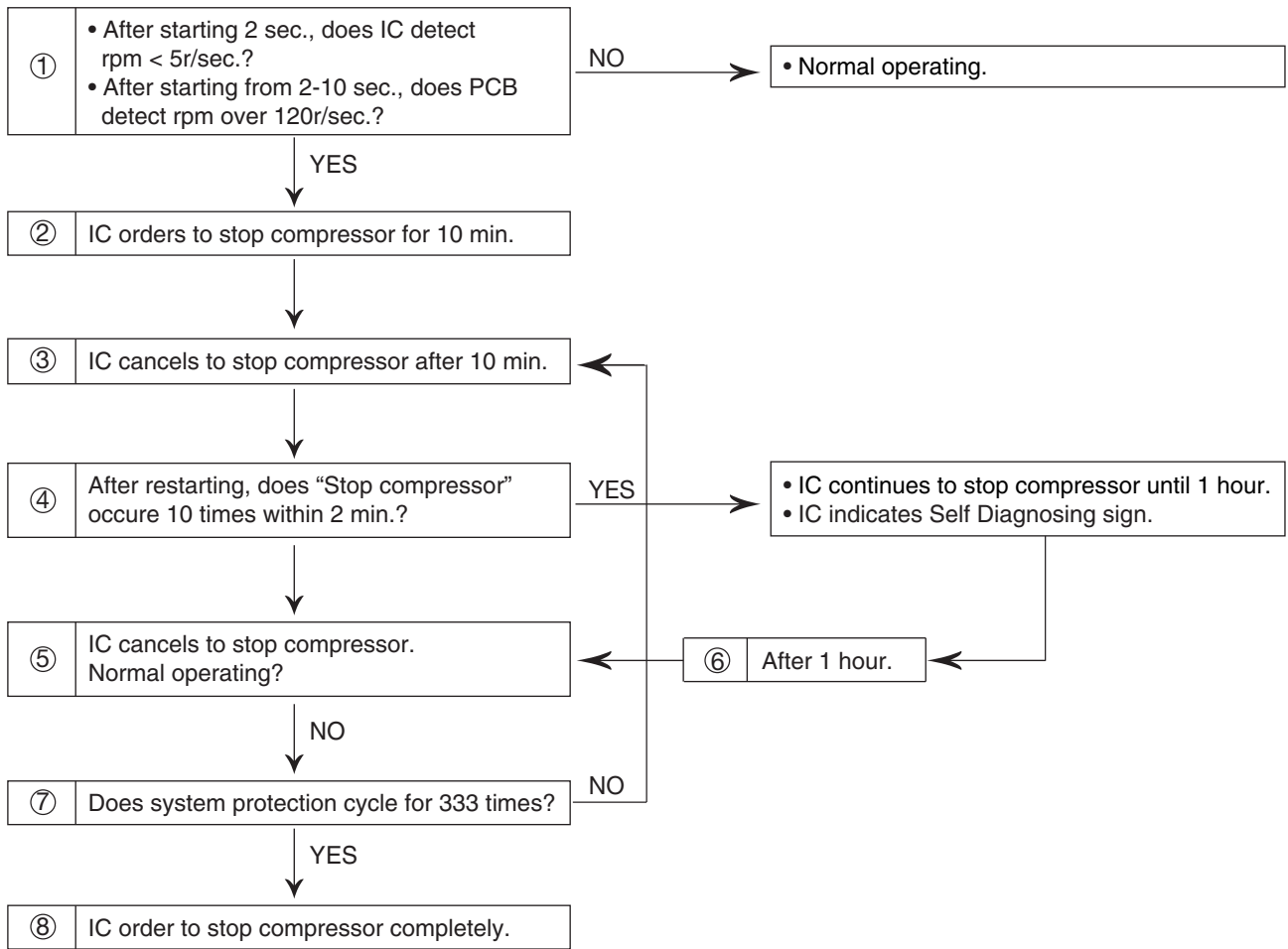

5.3 Protection for power supply dropping

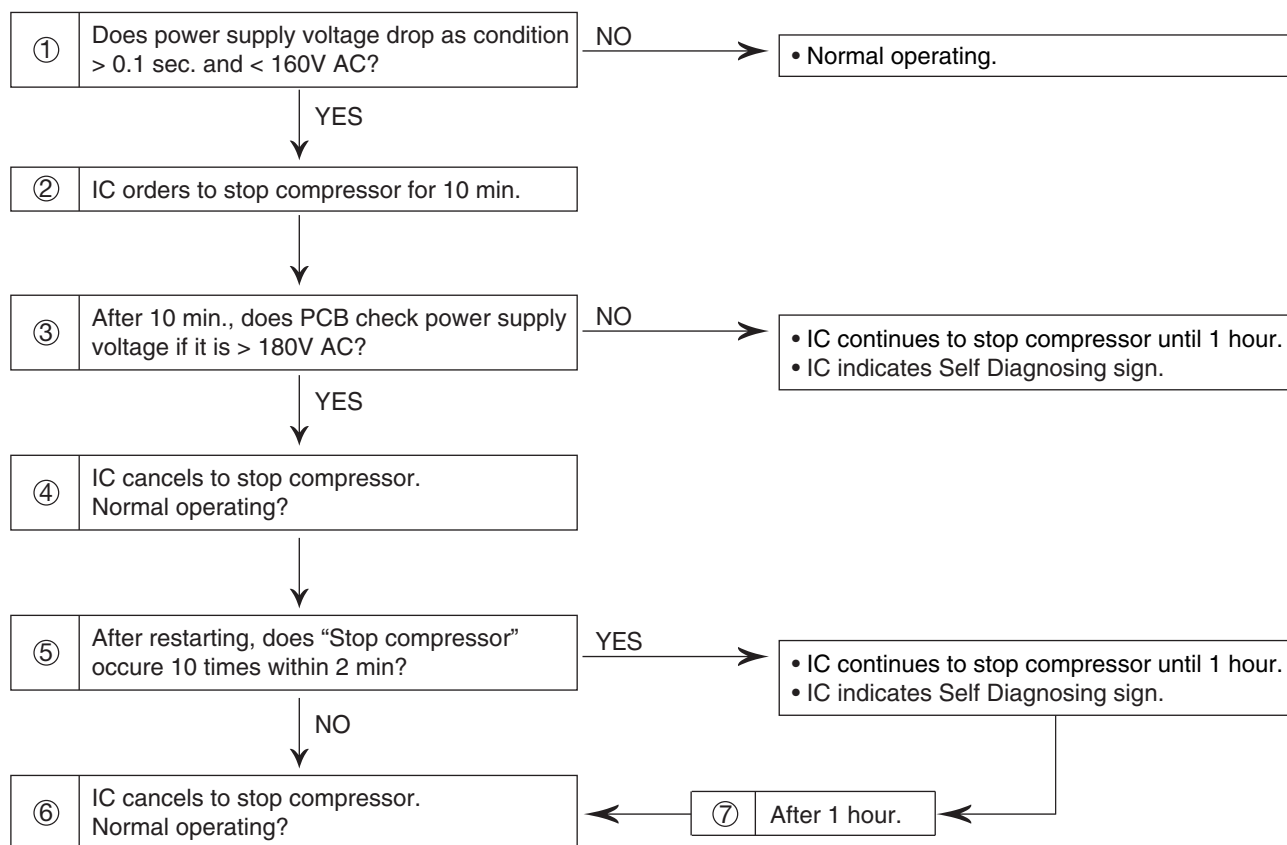

6. SELF DIAGNOSING FUNCTION

When abnormalist is cased in the refrigerator, the sign is displayed on LED as below chart.

How to use “Self Diagnosing” function

1. Opening PC door and FC door,
Push “Quick Freezing” bottom more than 5 sec.
2. After blinking at sec., each LED show as below.
3. “Self Diagnosing” function will be automatically cancel after 7 min., from start operation.

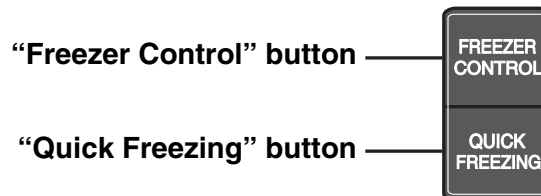

● Lighting ◎ Blinking ○ Off

	ECONAVI LED	QUICK LED	FC CONTROL LED		
			MAX	MED	MIN
FCC	○	◎	○	○	○
DFC	○	●	○	○	○
ATC	◎	●	○	○	○
FC FAN MOTOR	●	●	○	○	○
DEFROST HEATER	●	○	○	○	○
INV COMP	●	◎	○	○	○
PCB	◎	◎	○	○	○
HC LEAK (HIGH PRESSURE)	○	○	○	○	◎
HC LEAK (LOW PRESSURE)	○	○	◎	◎	◎
ILLUMINANCE SENSOR	◎	○	○	○	○

7. TEMPERATURE CONTROL

This refrigerator is special design for appropriate use, which can adjust the temperature level to details “9 Levels” with the following details.

How to operate the “9 Levels” mode

1. Set LED display to “MIN” with the “Freezer Control” button.
2. Press the “Freezer Control” button (for 10 seconds) until the LED display return to show at “MIN” position.
3. Set “9 Levels” mode following below table by pressing the “Freezer Control” button.

To reset the setting “9 Levels” mode

Repeat step 1 & 2, then the refrigerator return to normal operation mode.

Cooling Level					
	Minimum				
Step	1	2	3	4	5
Freezer Control LED Display					

Cooling Level				
		Maximum		
Step	6	7	8	9
Freezer Control LED Display				

Lighting Blinking

8. INVERTER CONTROL DISPLAY

How to operate the “Quick Freezing” mode

■ Quick Freezing

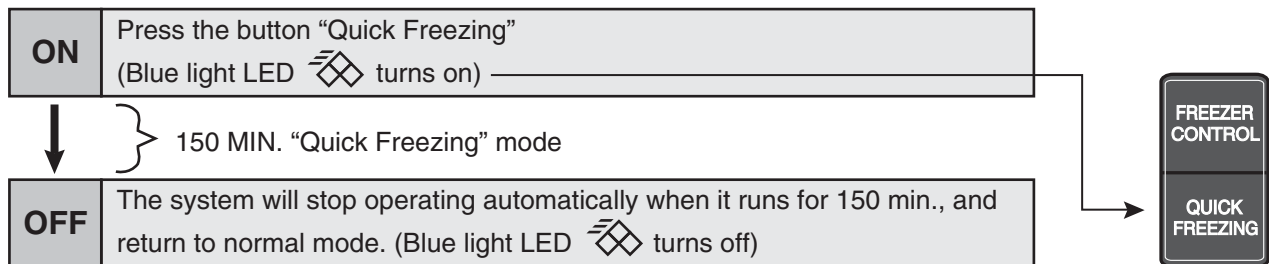

Remarks

- If you want to stop the operation, press the button “Quick Freezing”.
- Blue light LED  flashing means that the defrosting system is now working “Quick Freezing” mode will start right after the defrosting operation is finished.
- Freezer temp. control does not operate during “Quick Freezing” mode.
(The compressor rotation is at the maximum level for “Quick Freezing” mode)

9. REFRIGERATOR INSTRUCTION GUIDELINE

1. Do not open the refrigerator frequently or leave it open for a long time. This is to prevent water dripping inside the refrigerator which will cause the waste of coolness and consuming of energy.
2. Do not refrigerate unnecessary items or hard-to-rot foodstuff such as pumpkin, shallot, garlic, potato as it will make the refrigerator to work over load and waste the storage space without necessity.
3. Adjust the temperature according to the actual operating condition for energy saving.
4. Do not refrigerate the bottles bigger than the door shelf or the tray as the door will not close completely, which will cause the leakage of coolness.
5. Frequently check the door opening seal, it must be closed to the refrigerator's body completely. Do not leave the seal dirty or damaged or deteriorated as the coolness will leak and will cause the consumption of the energy without necessity.
6. If you will not be at home for several days or there are nothing refrigerated in the refrigerator, the plug should be disconnected for energy saving. In this case, clean the refrigerator and leave it half-open to prevent bad odor.
7. Clean the drain tray located over the compressor at the back of the refrigerator every 3 months to prevent the odor generated from humidity.
8. Energy saving dryer pipes and heating pipes embedded around the refrigerator cabinet are helping to prevent "Condensation" on the outer surface of the cabinet without consuming energy. This will make the outer wall of the refrigerator get warm and that is not a malfunction.
9. Drinking water bottles, beverage bottles such as soft drinks and fruit juices should be sealed closely to prevent odor gets into the bottles.

Troubleshooting

Before calling for servicing, please check as follows.

The refrigerator does not operate.

- * Check to be sure that the plug and its socket are in good conditions.
- * Check that there is any problem on main fuse and electricity system in the house or not.

The cooling does not function properly.

- * Check to be sure that the temperature control button is at the proper position.
- * Check that the refrigerator is overloaded with stuff or there is any hot foodstuff refrigerated in it or not.
- * Is the refrigerator located exposing directly to sunlight or heat source?
- * Is the refrigerator door closed completely? Is the refrigerator opened frequently?

Vapor generated inside and outside the cabinet.

- * The Vapor will generated outside the cabinet when the humidity is high (e.g. during rainy season) or the air circulation is not good.
- * If the vapor generated inside the cabinet, check that the door is completely closed or not. Is the refrigerator frequently opened or left opened for a long time? Is there is any hot foodstuff refrigerated in it?

The refrigerator generates noise.

- * Check if the refrigerator is located on a stable floor or is installed properly.
- * Check if there is any object in contact with the refrigerator.

10. TROUBLESHOOTING GUIDE

10.1 Not cool at all [Both PC & FC (compressor does not operate)]

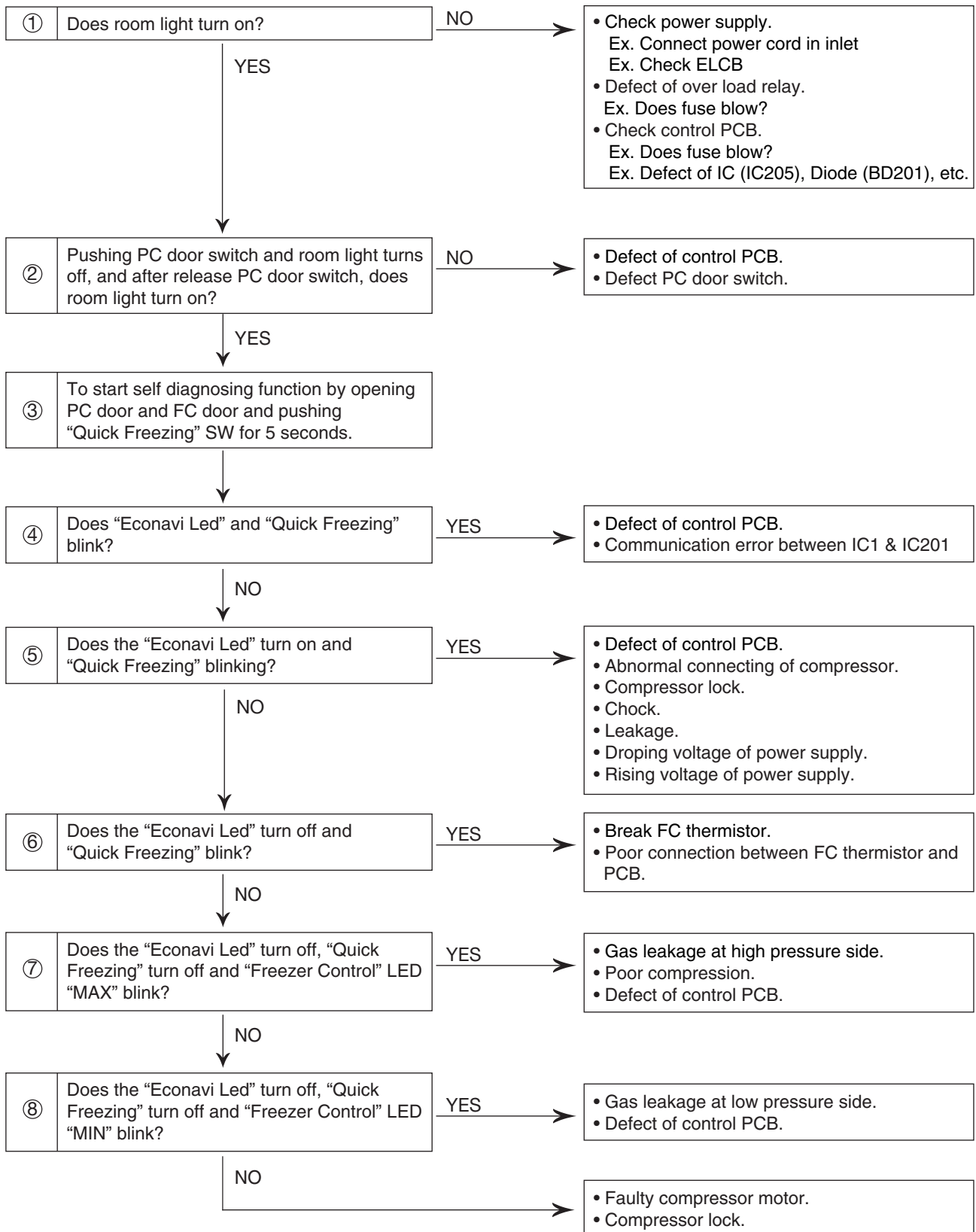

10.2 Cool, not enough [Both PC & FC (compressor operates)]

To confirm when compressor is operating.

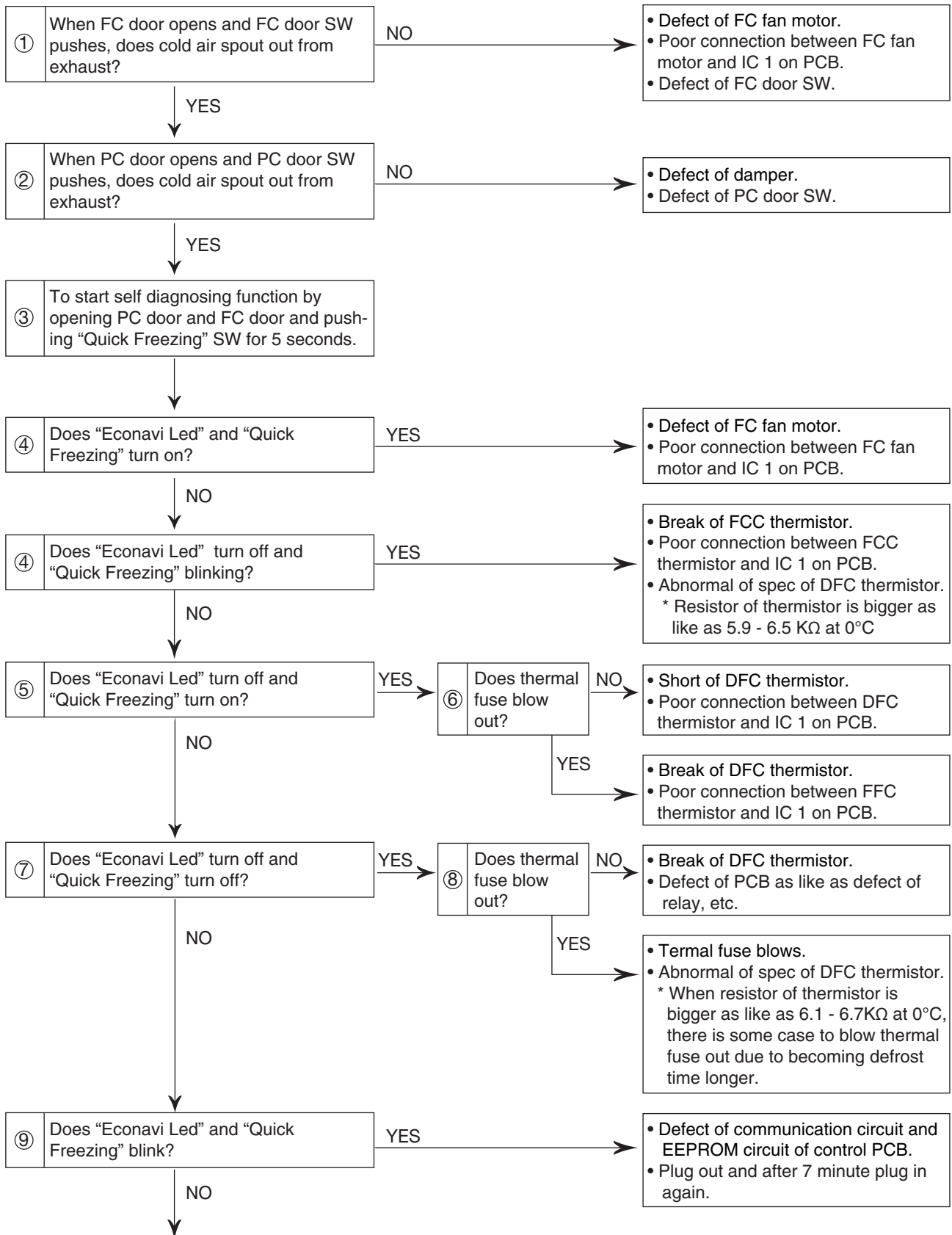

To confirm when compressor is operating.

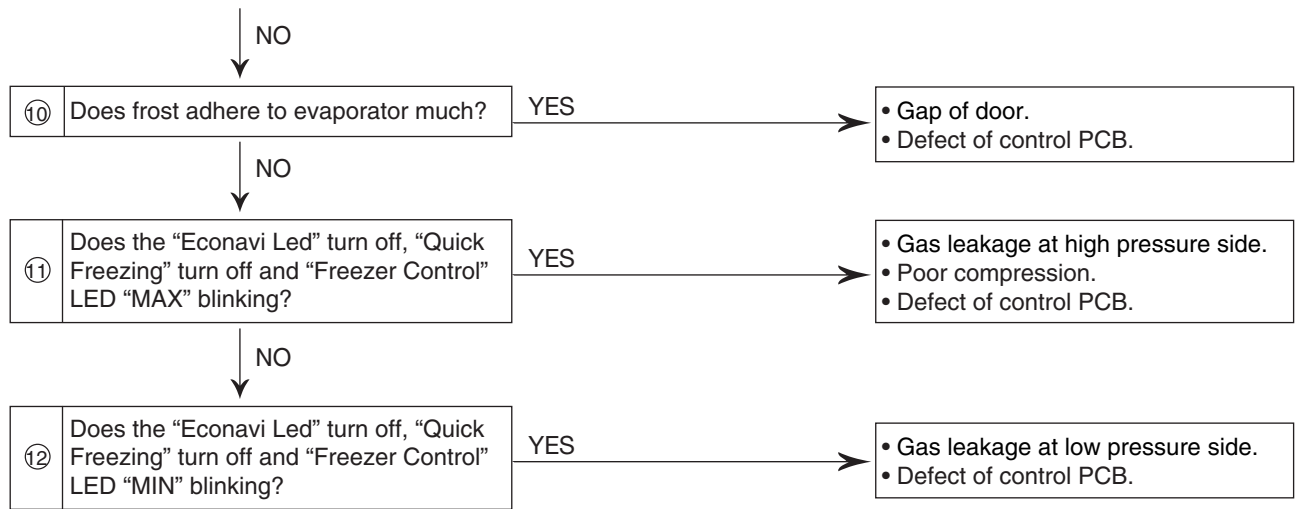

10.3 Eco-NavI operation doesn't work (PC/FC/IC cooling condition is normal)

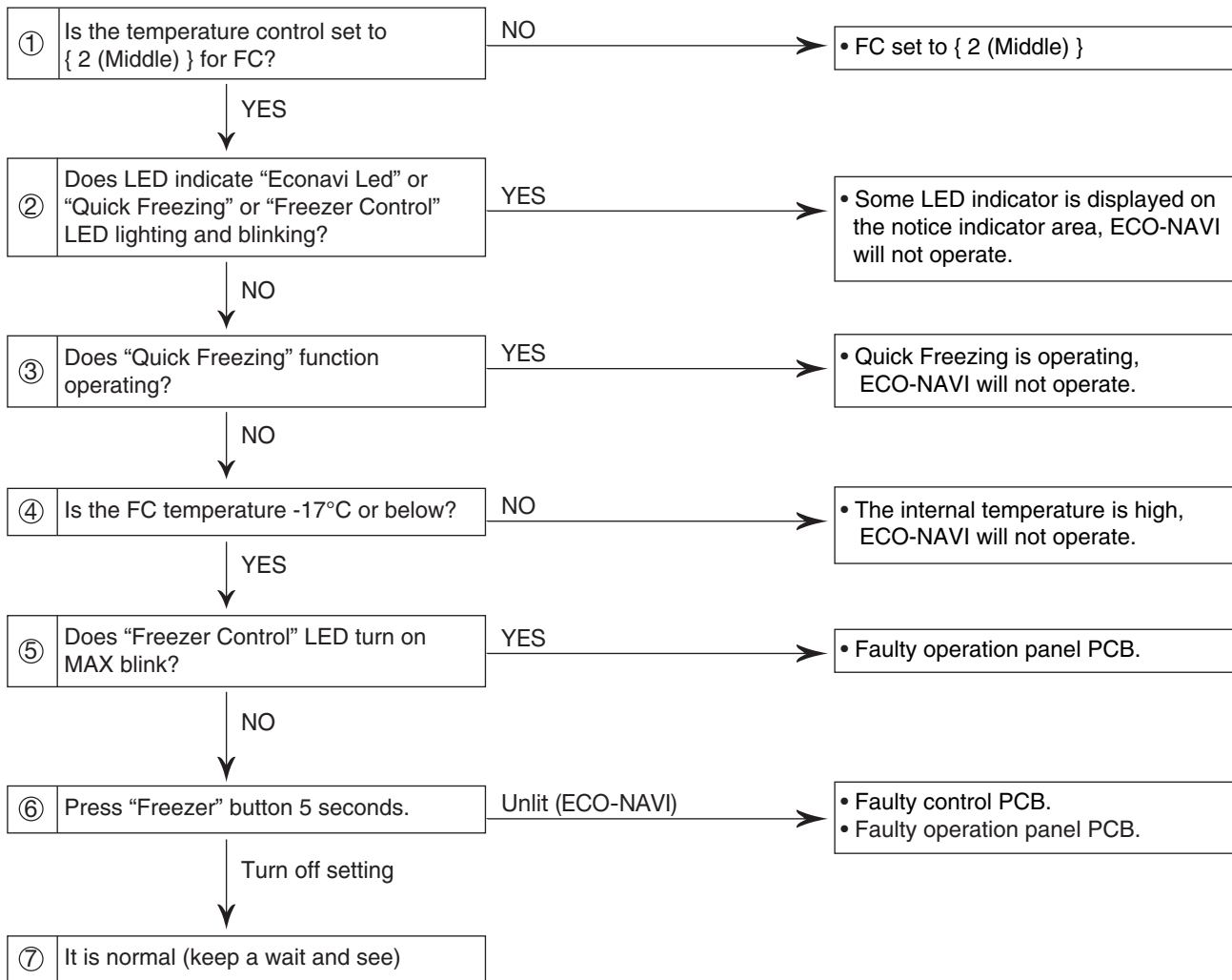

If it meets the above condition, ECO-NAVI operation begins and the lamp lights when the door opening and closing is not done for 3 hours. (with some exceptions)

Test of ECO-NAVI operation. (Quickly confirms for turning on the { ECO-NAVI } lamp)

White in service mode, shield the sensing part of ECO-NAVI sensor from the light.
Keep 1 minute without door opening and closing to turn on the { ECO-NAVI } lamp.

Precondition : The refrigerator compartment and freezer compartment are set to { 2 (Middle) }.

11. SCHEMATIC DIAGRAM

11.1 Wiring Diagram : NR-BY552XS, XW

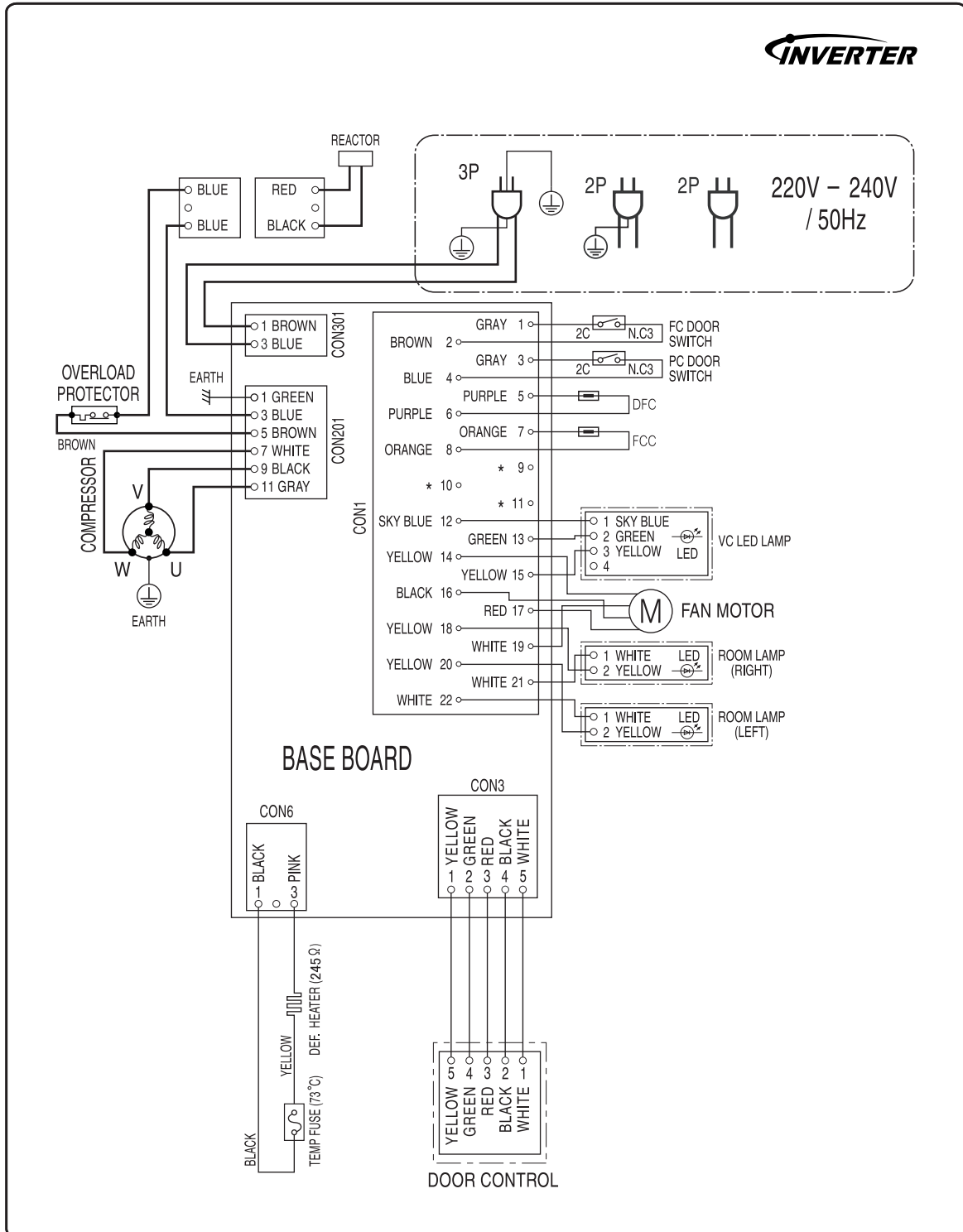

11.2 Wiring Diagram : NR-BY602XS

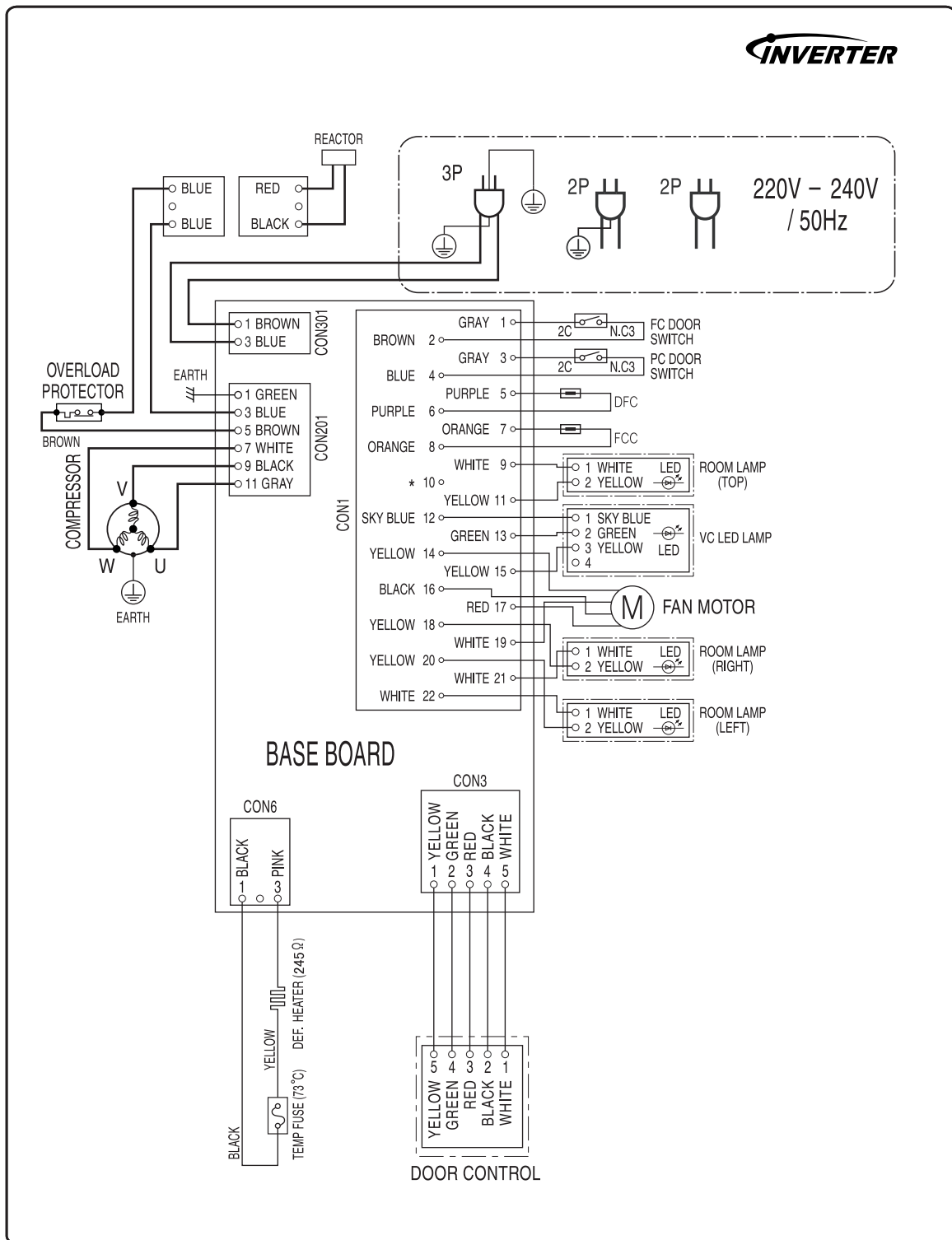

12. DISASSEMBLY INSTRUCTION

12.1 LCD Cover



Fig. 1

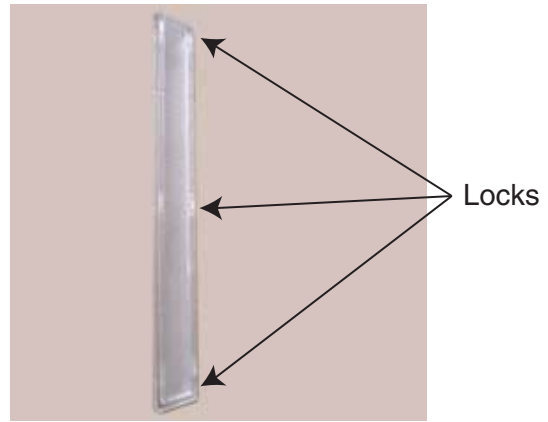

Fig. 2

- Take off LCD cover by use screwdriver put between gaps of LCD cover with liner at the lock point as Fig. 1.
- Check the locks point by see at "Arrow Mark" as Fig. 2.
- Use screwdriver push up the LCD cover for lock loose.



Fig. 3



Fig. 4



Fig. 5

- After change LCD lamp or LCD cover, put LCD cover at one side (left or right) and set locks in position as Fig. 3.
- Set LCD cover by see at the bottom of LCD cover as Fig. 4.
- Use hand hit carefully at LCD cover from the top pass to bottom as Fig. 5.

12.2 Cover Control



Fig. 1



Fig. 2

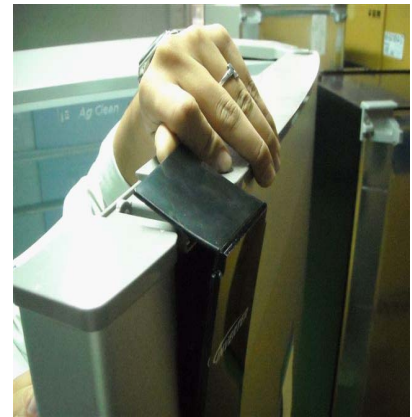

Fig. 3

- Take off Cover sheet at PC door by use cutter as Fig. 1.
- Take off screw at PC door by use screwdriver as Fig. 2.
- Push Cover control up and try to push it in front slowly for locks loose as Fig. 3.

12.3 PCB Control



Fig. 1



Fig. 2



Fig. 3

- Take off Lead wire socket which contact at PCB control as Fig. 1.
- Take off screw at PCB control as Fig. 2.
- Use screwdriver push up PAS-Control for loosening from locks slowly and prevention crack as Fig. 3.

12.4 Feature of Crisper

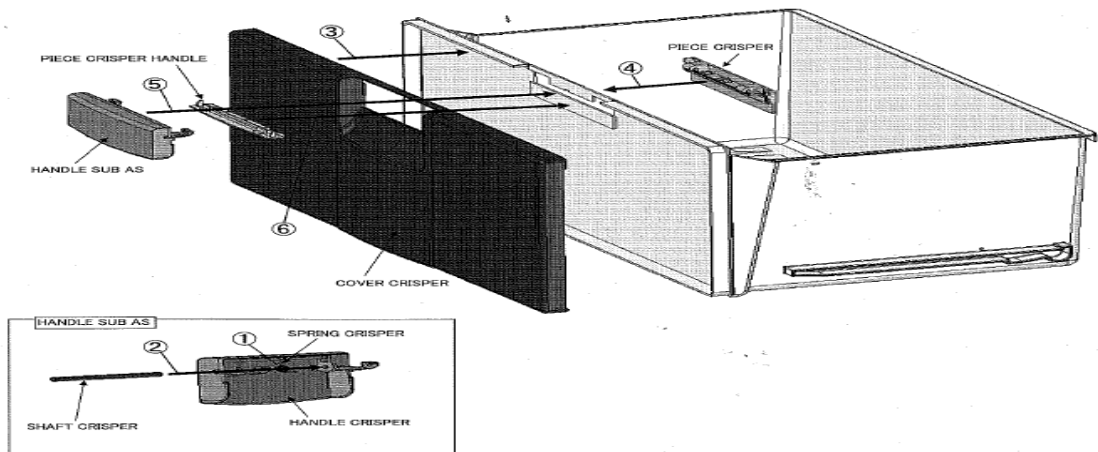

Fig. 1

- Explode part of Crisper As. as Fig. 1.

12.5 Maintain method : Take off Crisper handle



Fig. 2



Fig. 3

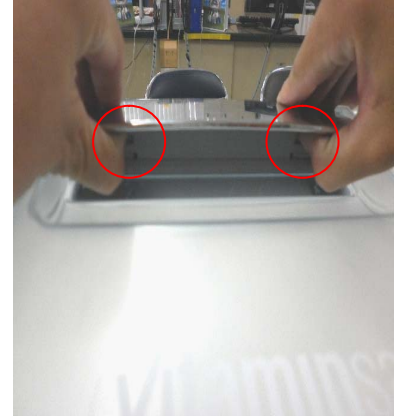

Fig. 4

- Actual part of Crisper handle as Fig. 2.
- Take off by use both thumbs press at buttons under Crisper handle for unlock (can hear 1 click each side) as Fig. 3 and Fig. 4.



Fig. 5



Fig. 6



Fig. 7

- Both hands hold Crisper handle and press down (about 45 degree) for unlock as Fig. 5.
- Both hands hold Crisper handle and carry up for unlock as Fig. 6.
- After take off Crisper handle and remain new piece as Fig. 7.

12.6 Maintain method : Crisper handle ass'y

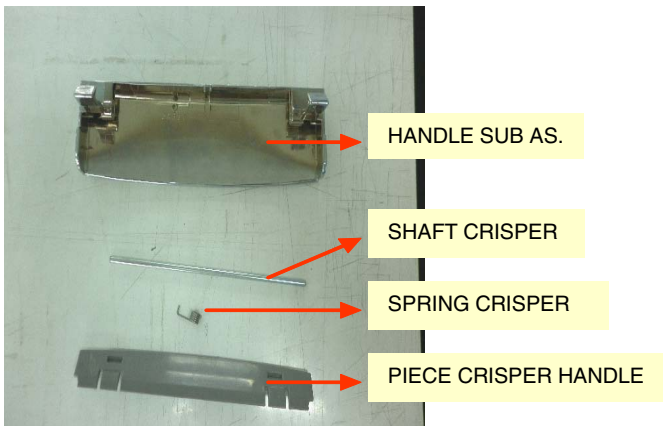

Fig. 8



Fig. 9

- Explode parts of Crisper handle as Fig. 8.
- To lock Spring crisper with Handle sub as. as Fig. 9.



Fig. 10

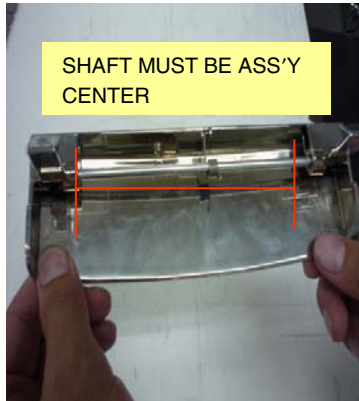

Fig. 11



Fig. 12

- To ass'y Shaft crisper from hole, left side through Spring crisper and finish at hole, right side as Fig. 10.
- To check Shaft crisper must be ass'y center as Fig. 11.
- Shaft crisper must be lock with hole complete as Fig. 12.



Fig. 13



Fig. 14



Fig. 15

- To check both hole of Piece crisper handle as Fig. 13.
- To carry up Handle sub as. with Spring crisper for ass'y lock as Fig. 14.
- To use finger with Spring crisper for ass'y lock with Piece crisper handle as Fig. 15.



Fig. 16



Fig. 17



Fig. 18

- Must be checked inside of Crisper handle to lock complete before use Piece crisper handle double lock (must be ass'y Piece crisper handle correct way as Fig. 16 & Fig. 17).
- To push down by both hands at Piece crisper handle for lock inside as Fig. 18.

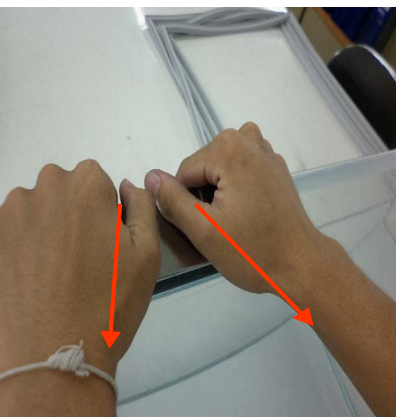

Fig. 19

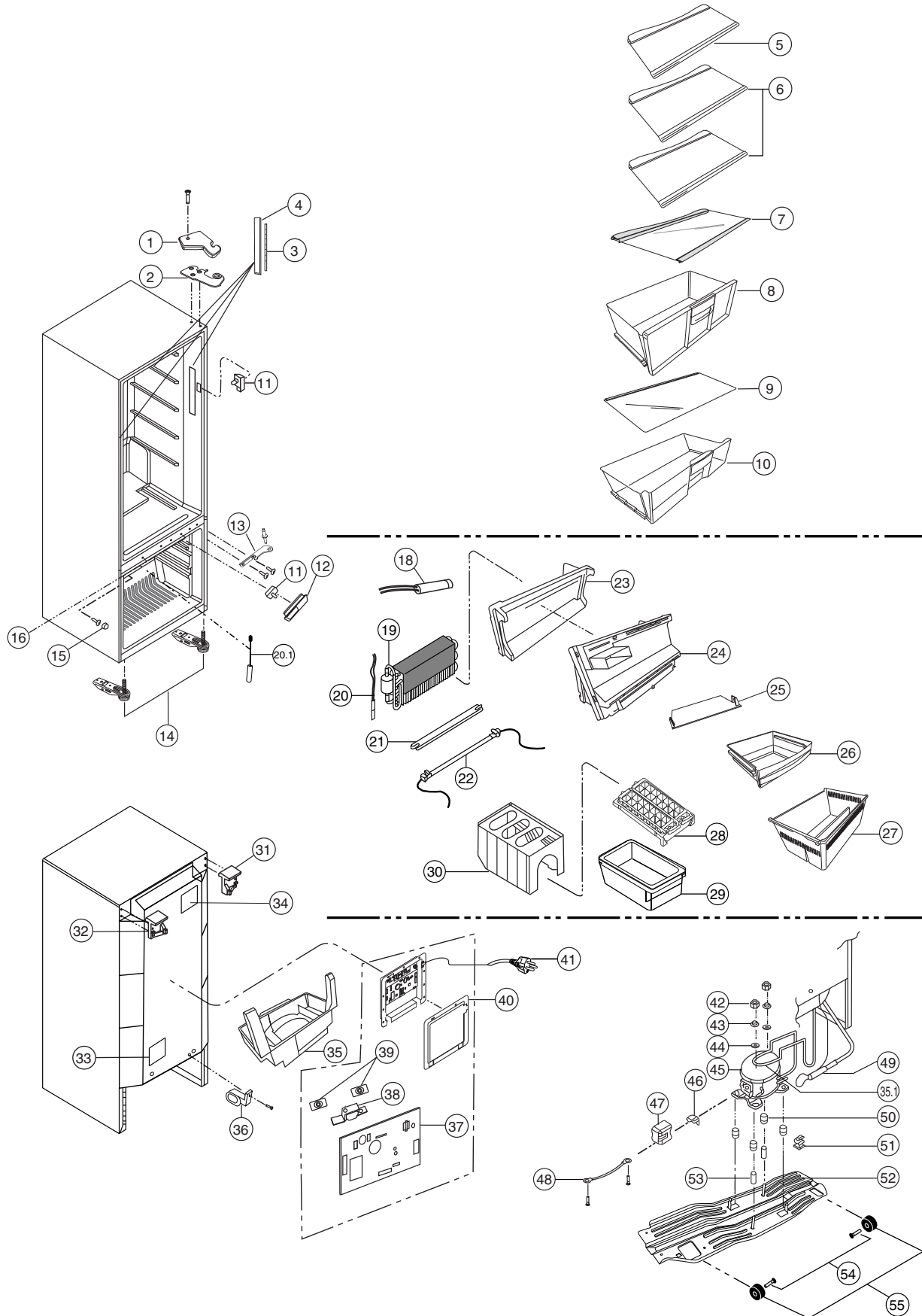

Fig. 20

- To push Crisper handle by both hands for lock it complete as Fig. 19.
- To check Crisper handle for lock complete as Fig. 20.

13. PARTS EXPLODED VIEW AND REPLACEMENT PARTS LIST

13.1 Parts Exploded View : Body



13.2 Parts Exploded View : Door

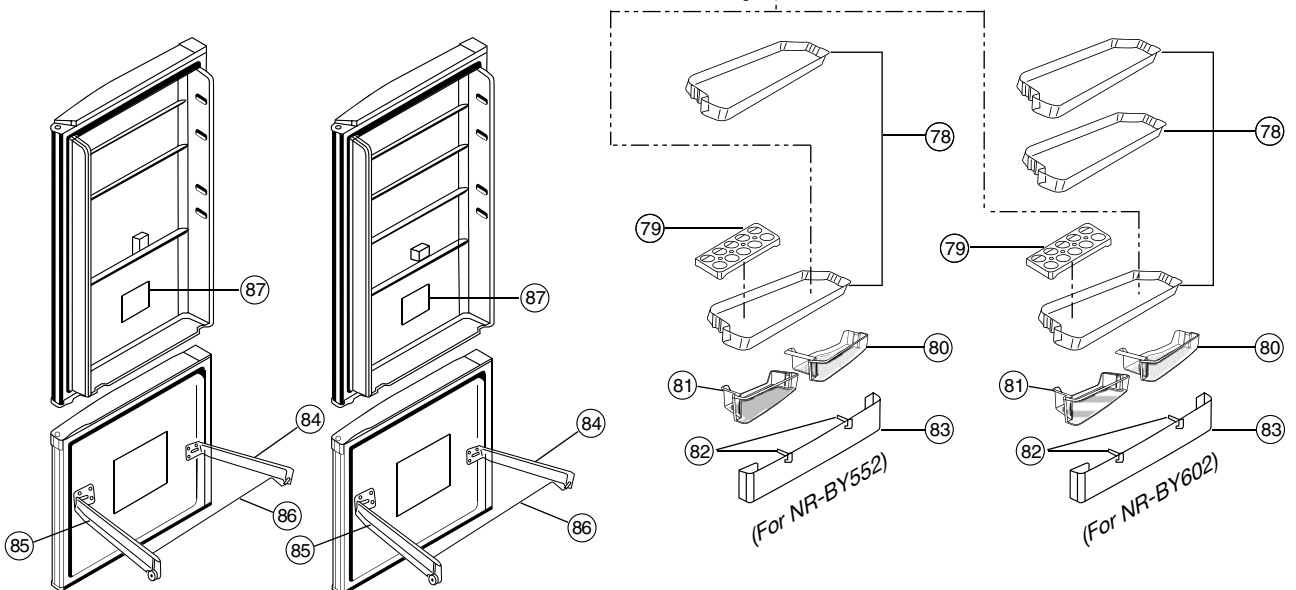
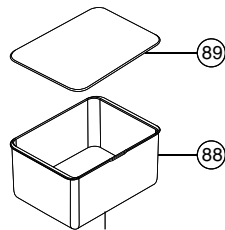
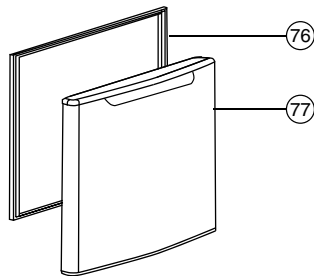
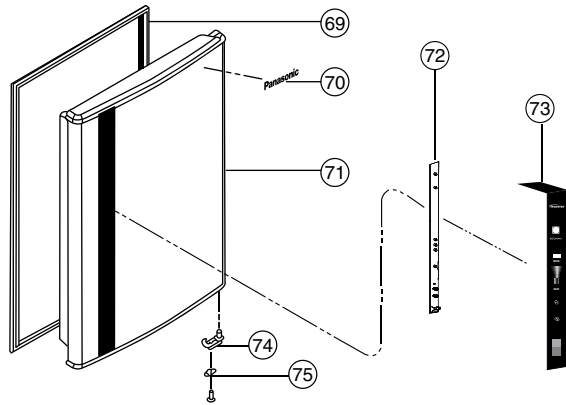
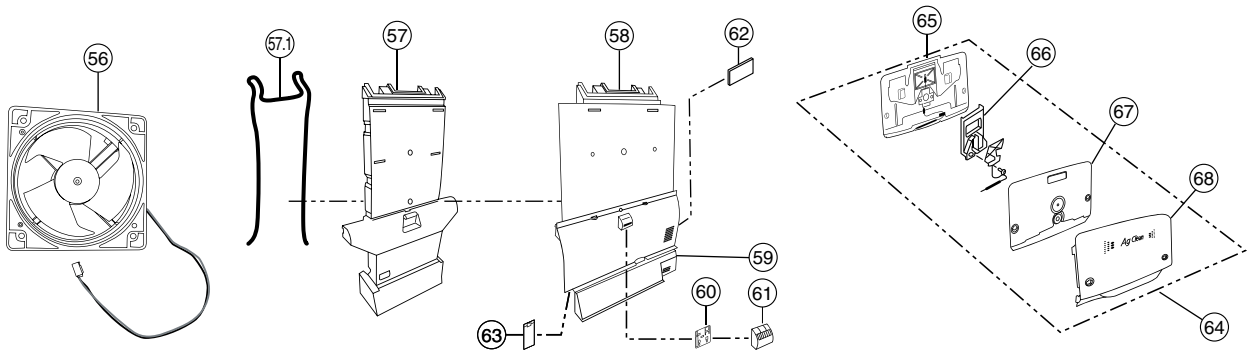

13.3 Parts Exploded View : Packing

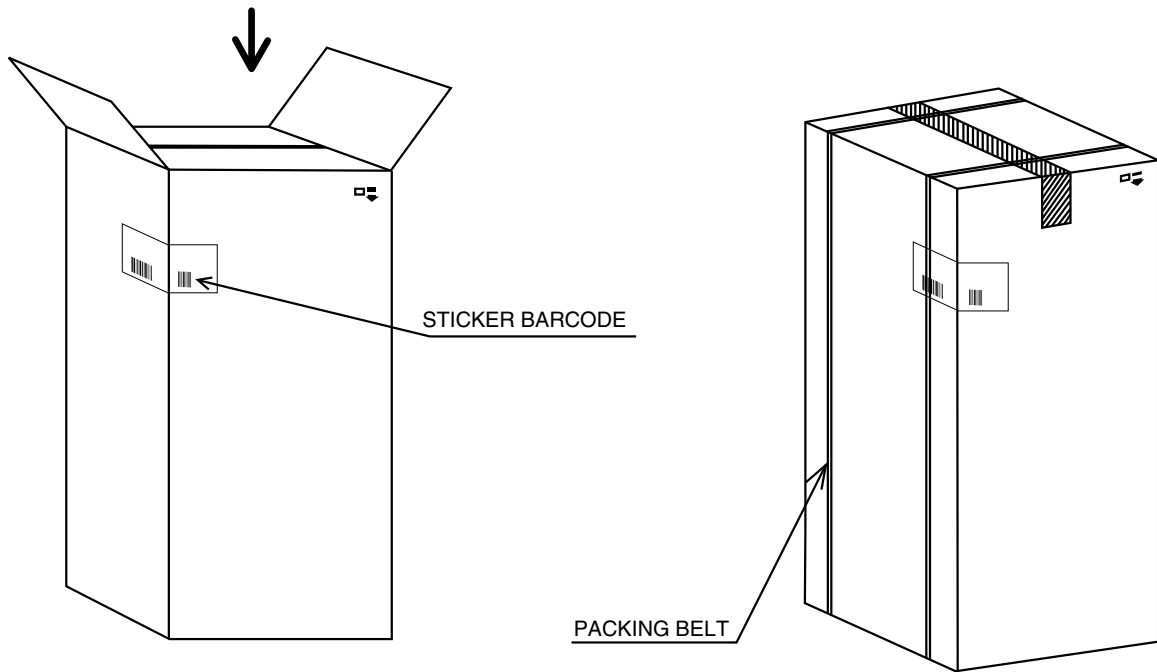

(FOR PROTECT GLASS TRAY SLIDE)

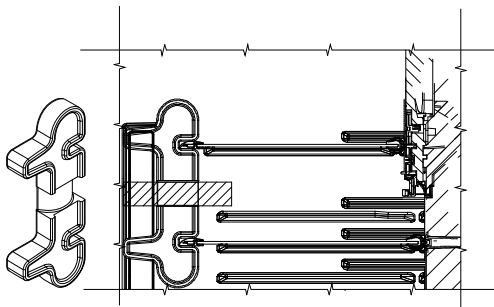

INS. PC PAD 552

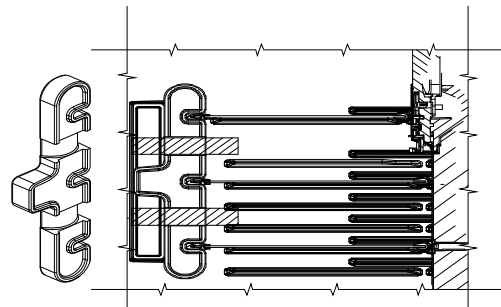

INS. PC PAD 602

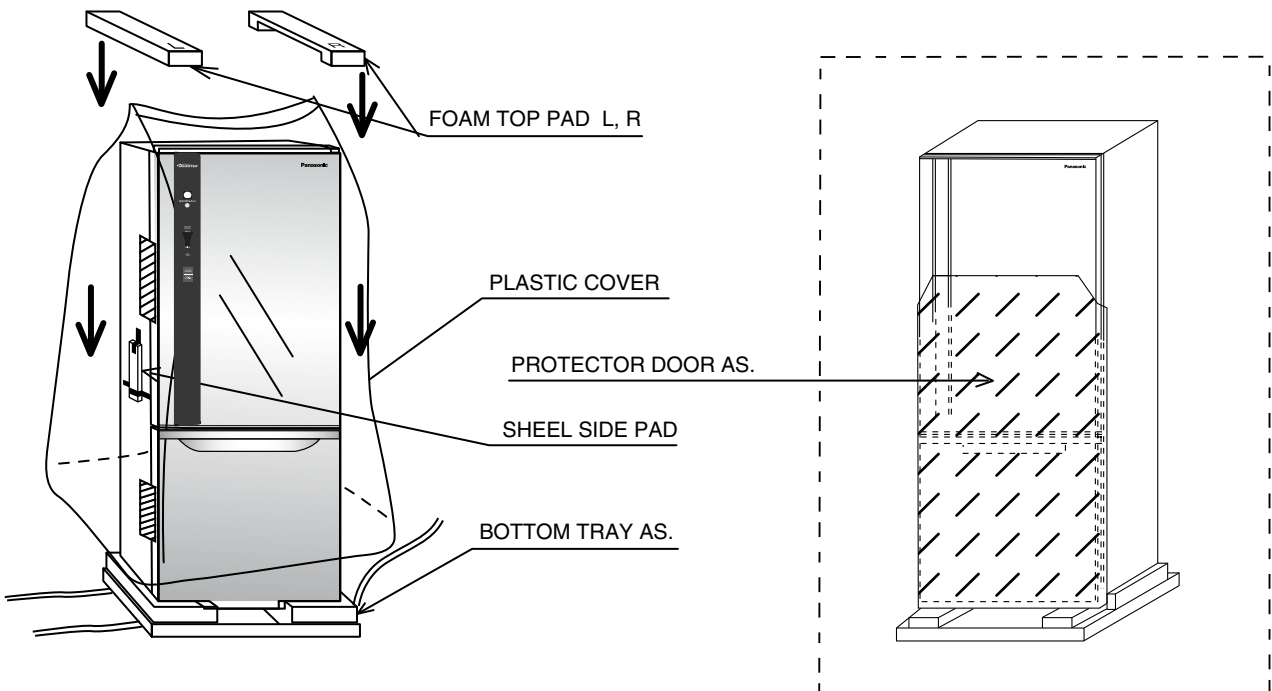

Important safety notice :

Components identified by mark have special characteristics important for safety.
When replacing any of these components, use only manufacturer's specified part.

13.4 Replacement Part List : NR-BY552XS, XW / NR-BY602XS**Parts List**

REF. NO.	PART NAME	PART. NO.	SAFETY	MODEL / Q'TY			REMARK
				BY552		BY602	
				XS	XW	XS	
1	COVER HINGE TOP - XS	CNRAE-139331		1		1	
	COVER HINGE TOP - XW	CNRAE-140950			1		
2	HINGE TOP	CNRAE-139022	S	1	1	1	
3	PAS-BW/BY (LED PCB)	CNRBG-181511		2	2	3	
4	COVER LED LAMP R	CNRAH-291582		1	1	1	SIDE : RIGHT
	COVER LED LAMP L	CNRAH-290283		1	1	2	SIDE : LEFT AND UPPER
5	GLASS TRAY TS AS.	CNRBH-139562		1	1	1	
6	GLASS TRAY T AS.	CNRBH-138623		1	1	2	
7	GLASS TRAY CRISPER AS.	CNRBH-138873		1	1	1	
8	CRISPER AS.	CNRBH-138642		1	1	1	
9	GLASS TRAY CHILLED AS.	CNRBH-138880		1	1	1	
10	CHILLED CASE	CNRAH-261152		1	1	1	
11	DOOR SW.	CNRAG-153290		2	2	2	
12	CASE SW. FC - W	CNRAC-201540		1	1	1	
13	HINGE CENTER	CNRAE-139010	S	1	1	1	
14	CASTER L AS.	CNRBC-324010		1	1	1	SIDE : LEFT
	CASTER R AS.	CNRBC-324020		1	1	1	SIDE : RIGHT
15	CAP PAN H. 4TS (ST)	CNR39-162720		1		1	
16	CAP PAN H. 4TS (W)	CNR39-162431		2	3	2	
18	SENSOR DEF.	CNRAF-140111		1	1	1	
19	COIL	CNRAF-177440		1	1	1	
20	TEMP. FUSE AS.	CNRBG-180841	S	1	1	1	
20.1	SENSOR FCC	CNRAG-164250		1	1	1	
21	COVER RADIANT	CNRAG-163050		1	1	1	
22	HEATER AS. DEFROST	CNRAG-163041	S	1	1	1	
23	INS. COVER COIL F	CNRAF-177452		1	1	1	
24	COVER COIL	CNRAF-177372		1	1	1	
25	PLATE FC	CNRAH-261411		1	1	1	
26	CASE FCT	CNRAH-261171		1	1	1	
27	CASE FCB AS.	CNRBH-138860		1	1	1	
28	ICE CUBE TRAY AS.	CNRBH-135250		1	1	1	
29	BOX ICE TRAY	CNRAH-227460		1	1	1	
30	HOLDER ICE TRAY	CNRAH-261194		1	1	1	
31	HANGER SHELL R	CNRAC-206002		1	1	1	SIDE : RIGHT
32	HANGER SHELL L	CNRAC-206012		1	1	1	SIDE : LEFT
33	LABEL HC BACK	CNRAH-269291	S	1	1	1	LANGUAGE : ENGLISH
		CNRAH-269301	S			1	LANGUAGE : THAI
34	WIRING DIAGRAM	CNRAH-297820		1			FOR XSTH
		CNRAH-293810		1			FOR XSMY
		CNRAH-293820		1			FOR XSSG
		CNRAH-293830		1			FOR XS1D
		CNRAH-293840		1			FOR XSVN
		CNRAH-293850		1			FOR XS1N
		CNRAH-293860		1			FOR XSAU/NZ
		CNRAH-293870		1			FOR XSPH
		CNRAH-293890			1		FOR XWAU/NZ
		CNRAH-293720				1	FOR XSTH
		CNRAH-293730				1	FOR XSMY
		CNRAH-293740				1	FOR XSSG
		CNRAH-293750				1	FOR XS1D
		CNRAH-293760				1	FOR XSVN
		CNRAH-293770				1	FOR XS1N
		CNRAH-293780				1	FOR XSPH
CNRAH-293790				1	FOR XSAE		
CNRAH-293800				1	FOR XSWG		
35	PAN WATER EVA. AS.	CNRBF-150371		1	1	1	
35.1	PIPE WATER EVA.	CNRAF-178940		1	1	1	
36	CLAMP PIPE WATER EVA.	CNRAF-175252		1	1	1	
37	PAS-BY602X (CONTROL)	CNRBG-182680		1	1	1	

Parts List

REF. NO.	PART NAME	PART. NO.	SAFETY	MODEL / Q'TY			REMARK
				BY552		BY602	
				XS	XW	XS	
38	REACTOR	CNRBG-165910		1	1	1	
39	RUBBER REACTOR	CNRAF-156140		2	2	2	
40	COVER CASE BOARD (GI)	CNRAC-214821		1	1	1	
41	SUPPLY CORD AS. - S3P	CNRBG-176222	S	1		1	XSMY, XSSG, XSAE
	SUPPLY CORD AS. - C2P	CNRBG-172281	S	1		1	XS1D, XSVN
	SUPPLY CORD AS. - B3P	CNRBG-172271	S	1		1	XS1N
	SUPPLY CORD AS. - K3P	CNRBG-185900	S	1	1		XSAU/NZ, XWAU/NZ
	SUPPLY CORD AS. - A2P	CNRBG-172291	S	1		1	XSPH
	SUPPLY CORD AS. - C3P	CNRBG-170952	S	1		1	XSTH
	SUPPLY CORD AS. - C2P (SHUKO)	CNRBG-176610	S			1	XSWG
42	HEXAGON NUT 8	CNR38-8170A1		2	2	2	
43	SPRING WASHER 8	CNR38-4270A0		2	2	2	
44	8 WASHER	CNR38-4170A0		2	2	2	
45	COMPRESSOR EF1100E13DGH	CNR91-236420		1	1	1	
46	MOTOR PROTECTOR	CNR06-598070	S	1	1	1	
47	PROTECTOR COVER	CNRAG-170460		1	1	1	
48	EARTH WIRE AS. COMP. 230	CNRBG-156650		1	1	1	
49	5 DRYER W	CNR39-340920		1	1	1	
50	RUBBER GROMMET	CNR01-249530		4	4	4	
51	CLAMPER DRYER	CNR39-163082		1	1	1	
52	CROSSRAIL REAR	CNRAF-177400		1	1	1	
53	SLEEVE COMP.	CNRAJ-112932		2	2	2	
54	PIN CASTER	CNR02-325701		2	2	2	
55	ROLLER 40	CNRAC-116280		2	2	2	
56	FAN MOTOR FC	CNRAG-145641		1	1	1	
57	INS. DUCT PC	CNRAH-261251		1	1		
		CNRAH-261241				1	
57.1	SEAL FOAM DUCT PC A	CNRAJ-167390		1	1		
		CNRAJ-167380				1	
58	PLATE DUCT PC	CNRAH-261212		1	1		
		CNRAH-261202				1	
59	PLATE DUCT PCB	CNRAH-261223		1	1	1	
60	LED KIBAN (VC)	CNRAG-163022		1	1	1	
61	COVER VC LED	CNRAH-261301		1	1	1	
62	AG BIO FILTER	CNRAH-245521		1	1	1	
63	PIECE DUCT PC	CNRAH-261460		1	1	1	
64	CONTROL PANEL AS.	CNRBH-145150		1	1	1	
65	INS. CONTROL PANEL PCB	CNRAH-261291		1	1	1	
66	BAFFLE DAMPER THERMO AS.	CNRBG-184010		1	1	1	
67	INS. CONTROL PANEL PCF	CNRAH-261282		1	1	1	
68	CONTROL PANEL	CNRAH-261231		1	1	1	
69	GASKET DOOR PC	CNRAD-330972		1	1		
		CNRAD-330962				1	
70	EMBLEM	CNRAD-330991		1	1	1	
71	DOOR AS. PC (FOAM) - XS	CNRBD-365781		1			
	DOOR AS. PC (FOAM) - XW	CNRBD-365792			1		
	DOOR AS. PC (FOAM) - XS	CNRBD-365771				1	
72	PAS-CONTROL (DOOR)	CNRBG-182670		1	1		
		CNRBG-182660				1	
73	COVER CONTROL (SUB) AS. BY552	CNRBD-374340		1			
		CNRBD-374880			1		
	COVER CONTROL (SUB) AS. BY602	CNRBD-374330				1	
74	LATCH DOOR	CNRAE-136513		1	1	1	
75	STOPPER DOOR	CNRAD-335500		1	1	1	
76	GASKET DOOR FC	CNRAD-330981		1	1	1	
77	DOOR AS. FC (FOAM) - XS	CNRBD-365720		1		1	
	DOOR AS. FC (FOAM) - XW	CNRBD-365730			1		
78	SHELF EGG	CNRAD-330772		2	2	3	
79	TRAY EGG 10	CNRAD-338110		1	1	1	
80	SHELF PC R	CNRAD-330711		1	1	1	
81	SHELF PC L	CNRAD-330701		1	1	1	
82	SLIDE STOPPER BOTTLE	CNRAD-330941		2	2	2	
83	SHELF BOTTLE	CNRAD-330693		1	1	1	
84	FRAME AS. FC R	CNRBD-340671		1	1	1	FIX BY TRUSS 5 TS16 / CNR38-195541
85	FRAME AS. FC L	CNRBD-340661		1	1	1	FIX BY TRUSS 5 TS16 / CNR38-195541

Parts List

REF. NO.	PART NAME	PART. NO.	SAFETY	MODEL / Q'TY			REMARK
				BY552		BY602	
				XS	XW	XS	
86	SUPPORT REAR	CNRAD-330951		1	1	1	
87	LABEL NAME	CNRAH-297790	S	1			FOR XSTH
		CNRAH-293540	S	1			FOR XSMY
		CNRAH-293550	S	1			FOR XSSG
		CNRAH-293560	S	1			FOR XS1D
		CNRAH-293570	S	1			FOR XSVN
		CNRAH-293580	S	1			FOR XS1N
		CNRAH-293590	S	1			FOR XSAU/NZ
		CNRAH-293600	S	1			FOR XSPH
		CNRAH-293620	S		1		FOR XWAU/NZ
		CNRAH-293450	S			1	FOR XSTH
		CNRAH-293460	S			1	FOR XSMY
		CNRAH-293470	S			1	FOR XSSG
		CNRAH-293480	S			1	FOR XS1D
		CNRAH-293490	S			1	FOR XSVN
		CNRAH-293500	S			1	FOR XS1N
CNRAH-293510	S			1	FOR XSPH		
CNRAH-293520	S			1	FOR XSAE		
CNRAH-293530	S			1	FOR XSWG		
88	UTILITY BOX	CNRAD-354431		1	1	1	
89	COVER UTILITY BOX	CNRAD-354441		1	1	1	

Packing List

REF. NO.	PART NAME	PART. NO.	SAFETY	MODEL / Q'TY			REMARK
				BY552		BY602	
				XS	XW	XS	
	PACKING AS.	CNRBK-129600		1			FOR XSTH
		CNRBK-127670		1			FOR XSMY
		CNRBK-127680		1			FOR XSSG
		CNRBK-127690		1			FOR XS1D
		CNRBK-127700		1			FOR XSVN
		CNRBK-127710		1			FOR XS1N
		CNRBK-127720		1			FOR XSAU/NZ
		CNRBK-127730		1			FOR XSPH
		CNRBK-127750			1		FOR XWAU/NZ
		CNRBK-127580				1	FOR XSTH
		CNRBK-127590				1	FOR XSMY
		CNRBK-127600				1	FOR XSSG
		CNRBK-127610				1	FOR XS1D
		CNRBK-127620				1	FOR XSVN
		CNRBK-127630				1	FOR XS1N
CNRBK-127640				1	FOR XSPH		
CNRBK-127650				1	FOR XSAE		
CNRBK-127660				1	FOR XSWG		
	BOTTOM TRAY AS.	CNRBK-119721		1	1	1	
	PLASTIC COVER	CNRAJ-162080		1	1		
		CNRAJ-162070				1	
	TOP PAD R	CNRAK-141801		1	1	1	SIDE : RIGHT
	TOP PAD L	CNRAK-141792		1	1	1	SIDE : LEFT
	INS. PC PAD 552	CNRAK-153040		2	2		FOR PROTECT GLASS TRAY SLIDE
	INS. PC PAD 602	CNRAK-153030				2	FOR PROTECT GLASS TRAY SLIDE
	SHELL SIDE PAD	CNRAK-142810		2	2	2	FOR BOTH SIDE
	PROTECTOR DOOR AS.	CNRBK-117320		1	1	1	
	INSTRUCTION BOOK	CNRAK-157170		1		1	FOR XSTH
		CNRAK-157180		1		1	FOR XSMY
		CNRAK-157190		1		1	FOR XSSG , XSPH
		CNRAK-157200		1		1	FOR XS1D
		CNRAK-157210		1		1	FOR XSVN
		CNRAK-157220		1		1	FOR XS1N
		CNRAK-157240				1	1
CNRAK-157250		1	1			FOR XSAU/NZ, XWAU/NZ	

DETAIL CHANGE NOTICE

REVISION	ITEM NO.	PAGE	DETAIL	REMARK
JAN. 2012	1	4	ADD THAILAND MODEL	FOR MODEL : NR-BY552XS
	2	29 - 31	ADD PART NAME & NO. AND Q'TY	FOR MODEL : NR-BY552XSTH
FEB. 2012	1	26, 29	ADD SENSOR FCC	ADD PICTURE, PART NAME & NO.
FEB. 2014	1	26, 29	REVISE PICTURE AND ADD PART NAME & NO. OF PIPE WATER EVA.	FOR SALES AS SERVICE PART
	2	27, 30	ADD PICTURE AND PART NAME & NO. OF SEAL FOAM DUCT PC A PART	FOR SALES AS SERVICE PART