





CONTENT

	Page
1. Safety caution for repairing	3
1.1 Warning	
1.2 Caution	
2. Specification and components	
2.1 NR- BK266 SERIES	4
2.2 NR- BK306 SERIES	5
2.3 NR- BK346 SERIES	6
3. Schematic diagram	7
4. Performance data	8
4.1 NR- BK266 SERIES	
4.2 NR- BK306 SERIES	
4.3 NR- BK346 SERIES	
5. Troubleshooting guide	9
6. Disassembly instruction with BK series in English	10-14
6.1 Freezer Compartment	
6.2 Provision Compartment	
6.3 Machine room	
6.4 Replace FC/PC door	
6. Disassembly instruction with BK series in Vietnamese	15-19
7. Parts exploded view and replacement parts list.	
7.1 Parts exploded view: Body	20
7.2 Parts exploded view: Machine room & Door	21
7.3 Parts exploded view: Packing	22-24
7.4 Replacement part list : NR-BK266 SERIES	25-26
7.5 Replacement part list : NR-BK306 SERIES	27-28
7.6 Replacement part list : NR-BK346 SERIES	29-30







1. SAFETY CAUTION FOR REPAIRING

When you repair the refrigerator, please kindly take care for the following cautions

1.1 Warning

	Before repairing unit, unplug supply cord <ul style="list-style-type: none">• Before you repair the refrigerator, please unplug the supply cord
	Use authentic parts when replacing <ul style="list-style-type: none">• When you replace the parts, please use authentic parts to replace defective parts.
	Caution during brazing <ul style="list-style-type: none">• When you use touch for brazing, please ensure ventilation. Otherwise, you will be poisoned by carbon monoxide.
	Pay attention to using refrigerant <ul style="list-style-type: none">• If refrigerant touches fire, the gas becomes poisonous gas.
	Pay attention to getting electricity shock <ul style="list-style-type: none">• When you check the voltage of terminal, please do not touch the electricity part terminal.• When you replace the parts, please wait for 3 minutes at least for discharging capacitor.
	Check safety after repairing <ul style="list-style-type: none">• Check the screws, parts, lead wires to take in place.• Check the repairing portion whether circumferential parts are damaged or not.• Check insulation resistance between supply plug and earth.• When install refrigerator, check condition of supply cord and plug.• Wipe off the dust on plug.• Cutting and seal the electric device carefully.

1.2 Caution

	Watch the hot parts <ul style="list-style-type: none">• During operation and after operation, compressor and pipes are hot.• Also, under these condition, heater are hot.• Do not burn your fingers when you touch it.
	Pay attention to refrigerant <ul style="list-style-type: none">• Do not touch liquid refrigerant. Otherwise your hands may be burnt.
	Pay attention to edge of parts <ul style="list-style-type: none">• Otherwise, your fingers may be cut.
	Pay attention to fins of evaporator and condenser <ul style="list-style-type: none">• Otherwise, your fingers may be cut.
	Before transportation, adjust the bolt <ul style="list-style-type: none">• Otherwise, the floor may be damaged.
	Do not touch the pipe after brazing <ul style="list-style-type: none">• Otherwise, your hands may be burnt.

2. SPECIFICATION AND COMPONENTS

2.1 NR-BK266 SERIES

Model	NR-BK266SN, MS, GS					
Destination	Vietnam	RBD	Malaysia	Sin-DBD	Hong Kong	
Code Attached Model	VN	WA	MY	SG	HK	
Power Source	220V	220~240V	240V	230V	220V	
Plug	C2P	C2P	S3P	S3P	S3P	
Colour Model	SN,MS,GS	SN	SN	SN,GS	SN,MS	
Colour Code	N,S	N	N	N,S	N,S	
System Spec.	Induction					
Material Spec.	PCM = SN, VCM = MS, GS					

Specification

Capacity (*)	Total Volume	262L	262L	262L	262L	234L
	FC	94L	94L	94L	94L	75L
	PC	168L	168L	168L	168L	159L
Internal Dimension [W x D x H]	FC	479 x 445x 443 (mm.)				
	PC	503 x 457 x 796.5 (mm.)				
External Dimension	600 x 614 x 1449 (mm.)					
Installation Space	Side : 50 mm min. / Back : 100 mm min. / Top : 300 mm min.					
Temperature Control	FC	Cold Air Control: Slide shutter				
	PC	PAS - BJ175(Control) , PAS - BK305S(Main)				
Radiant Heater	Type	MM6-4400				
	Rating	220V / 150W				
Defrosting Control	Defrost Cycle	(1) Ambient temp. over 33° C, 8.5h				
		(2) Ambient temp. 25° C ~ 33° C, 8.5h				
		(3) Ambient temp. under 16° C, 13h				
		(4) Power on 4h (Rated time)				
Inner Liner	Vacuum formed HI-PS / Cabinet and door					
Insulation	Cyclo-Pentane / Cabinet and door					
Net Weight	43 Kg					

Sealed Unit

Evaporator	Fin and tube type					
Condenser	Single wall steel tube (Zinc coat), wrapper type					
Compressor	SF51C91RAW5					
Refrigerant	Type	HFC-134a				
	Charging Amt.	120 ± 5g				
Lubricating Oil	Type	α -22				
	Charging Amt.	195 ± 5ml				

Electric Part

Door Switch	Type	S.P. - S.T. / D3D - 121 (Omron)				
	Rating	250V / 0.5A				
Fan Motor	Type	3612JL-04W-S40-G03,Ø81 PROP FAN (BOX TYPE)				
	Rating	DC12V / 0.3A / 3.6W				
Compressor Motor	Type	EQ-BR21, 220V 50Hz/ 2 poles				
	Rating	107W				
PC Sensor (PCC)	Type	NTC				
	Rating	B=3808K / -20/0° C, R0=6.409KΩ± 1 %				
Defrost Sensor (DFC)	Type	NTC				
	Rating	B=3819K ± 2%				
		R10=3.899KΩ± 3%				
Ambient Temp. Sensor (ATC)	Type	NTC				
	Rating	B = 3435K ± 1%				
		R25 = 10.0KΩ ± 3%				
Defrost Thermal Fuse	Type	Micro Temp.				
	Rating	250V / 10A / 73° C				
Running Capacity	Type	401405L				
	Rating	4 μ F - 400V				
Starting Relay	PTH7M330MD2					
Overload Protector	5TM181NHBY					
Light Irradiation Device (PC)	LED Lamp PCB / 12V, 60 mA					

Note: (*) Hong Kong models base on ISO 8561, Malaysia models base on IEC62552. Other models base on ISO 15502.

2.2 NR-BK306 SERIES

Model	NR-BK306SN,MS, GS						
Destination	Vietnam	RBD	Malaysia	Sin-DBD	Hong Kong	PGF	GULF
Code Attached Model	VN	WA	MY	SG	HK	WG	AE
Power Source	220V	220~240V	240V	230V	220V	220~240V	220~240V
Plug	C2P	C2P	S3P	S3P	S3P	C2P(SHUKO)	S3P
Colour Model	SN,MS,GS	SN	SN,MS	SN,GS	SN,MS	SN	SN
Colour Code	N,S	N	N,S	N,S	N,S	N	N
System Spec.	Induction						
Material Spec.	PCM = SN, VCM = MS, GS						

Specification

Capacity (*)	Total Volume	296L	296L	296L	296L	267L	296L	296L
	FC	94L	94L	94L	94L	75L	94L	94L
	PC	202L	202L	202L	202L	192L	202L	202L
Internal Dimension [W x D x H]	FC	479 x 445 x 443 (mm.)						
	PC	503 x 457 x 932.5 (mm.)						
External Dimension	600 x 614 x 1585 (mm.)							
Installation Space	Side : 50 mm min. / Back : 100 mm min. / Top : 300 mm min.							
Temperature Control	FC	Cold Air Control: Slide shutter						
	PC	PAS - BJ175(Control) , PAS - BK305S(Main)						
Radiant Heater	Type	MM6-4400						
	Rating	220V / 150W						
Defrosting Control	Defrost Cycle	(1) Ambient temp. over 33° C, 8.5h						
		(2) Ambient temp. 25° C - 33° C, 8.5h						
		(3) Ambient temp. under 16° C, 13h						
		(4) Power on 4h (Rated time)						
Inner Liner	Vacuum formed HI-PS / Cabinet and door							
Insulation	Cyclo-Pentane / Cabinet and door							
Net Weight	45 Kg							

Sealed Unit

Evaporator	Fin and tube type							
Condenser	Single wall steel tube (Zinc coat), wrapper type							
Compressor	SF51C91RAW5							
Refrigerant	Type	HFC-134a						
	Charging Amt.	120 ± 5g						
Lubricating Oil	Type	α -22						
	Charging Amt.	195 ± 5ml						

Electric Part

Door Switch	Type	S.P. - S.T. / D3D - 121 (Omron)						
	Rating	250V / 0.5A						
Fan Motor	Type	3612JL-04W-S40-G03,Ø81 PROP FAN (BOX TYPE)						
	Rating	DC12V / 0.3A / 3.6W						
Compressor Motor	Type	EQ-BR21, 220V 50Hz/ 2 poles						
	Rating	107W						
PC Sensor (PCC)	Type	NTC						
	Rating	B=3808K / -20/0° C, R0=6.409KΩ ± 1 %						
Defrost Sensor (DFC)	Type	NTC						
	Rating	B=3819K ± 2%						
		R10=3.899KΩ ± 3%						
Ambient Temp. Sensor (ATC)	Type	NTC						
	Rating	B = 3435K ± 1%						
		R25 = 10.0KΩ ± 3%						
Defrost Thermal Fuse	Type	Micro Temp.						
	Rating	250V / 10A / 73° C						
Running Capacity	Type	401405L						
	Rating	4 μF - 400V						
Starting Relay	PTH7M330MD2							
Overload Protector	5TM181NHBYY							
Light Irradiation Device (PC)	LED Lamp PCB / 12V, 60 mA							

Note: (*) Hong Kong models base on ISO 8561, Malaysia models base on IEC62552. Other models base on ISO 15502

2.3 NR-BK346 SERIES

Model	NR-BK346SN,MS,GS						
Destination	Vietnam	RBD	Malaysia	Sin-DBD	Hong Kong	PGF	GULF
Code Attached Model	VN	WA	MY	SG	HK	WG	AE
Power Source	220V	220~240V	240V	230V	220V	220~240V	220~240V
Plug	C2P	C2P	S3P	S3P	S3P	C2P(SHUKO)	S3P
Colour Model	SN,MS,GS	SN	SN,MS	SN,GS	SN,MS	SN	SN
Colour Code	N,S	N	N,S	N,S	N,S	N	N
System Spec.	Induction						
Material Spec.	PCM = SN, VCM = MS, GS						

Specification

Capacity (*)	Total Volume	333L	333L	333L	333L	303L	333L	333L
	FC	94L	94L	94L	94L	75L	94L	94L
	PC	239L	239L	239L	239L	228L	239L	239L
Internal Dimension [W x D x H]	FC	479 x 445 x 443 (mm.)						
	PC	503 x 457 x 1085.5 (mm.)						
External Dimension	600 x 614 x 1738 (mm.)							
Installation Space	Side : 50 mm min. / Back : 100 mm min. / Top : 300 mm min.							
Temperature Control	FC	Cold Air Control: Slide shutter						
	PC	PAS - BJ175(Control) , PAS - BK305S(Main)						
Radiant Heater	Type	MM6-4400						
	Rating	220V / 150W						
Defrosting Control	Defrost Cycle	(1) Ambient temp. over 33° C, 8.5h						
		(2) Ambient temp. 25° C - 33° C, 8.5h						
		(3) Ambient temp. under 16° C, 13h						
		(4) Power on 4h (Rated time)						
Inner Liner	Vacuum formed HI-PS / Cabinet and door							
Insulation	Cyclo-Pentane / Cabinet and door							
Net Weight	49 Kg							

Sealed Unit

Evaporator	Fin and tube type							
Condenser	Single wall steel tube (Zinc coat), wrapper type							
Compressor	SF51C91RAW5							
Refrigerant	Type	HFC-134a						
	Charging Amt.	120 ± 5g						
Lubricating Oil	Type	α -22						
	Charging Amt.	195 ± 5ml						

Electric Part

Door Switch	Type	S.P. - S.T. / D3D - 121 (Omron)						
	Rating	250V / 0.5A						
Fan Motor	Type	3612JL-04W-S40-G03,Ø81 PROP FAN (BOX TYPE)						
	Rating	DC12V / 0.3A / 3.6W						
Compressor Motor	Type	EQ-BR21, 220V 50Hz/ 2 poles						
	Rating	107W						
PC Sensor (PCC)	Type	NTC						
	Rating	B=3808K / -20/0° C, R0=6.409KΩ ± 1 %						
Defrost Sensor (DFC)	Type	NTC						
	Rating	B=3819K ± 2% R10=3.899KΩ ± 3%						
Ambient Temp. Sensor (ATC)	Type	NTC						
	Rating	B = 3435K ± 1% R25 = 10.0KΩ ± 3%						
Defrost Thermal Fuse	Type							
	Rating	250V / 10A / 73° C						
Running Capacity	Type	401405L						
	Rating	4 μF - 400V						
Starting Relay	PTH7M330MD2							
Overload Protector	5TM181NHBYY							
Light Irradiation Device (PC)	LED Lamp PCB / 12V, 60 mA							

Note: (*) Hong Kong models base on ISO 8561, Malaysia models base on IEC62552. Other models base on ISO 15502

3. SCHEMATIC DIAGRAM

NR-BK266 SERIES

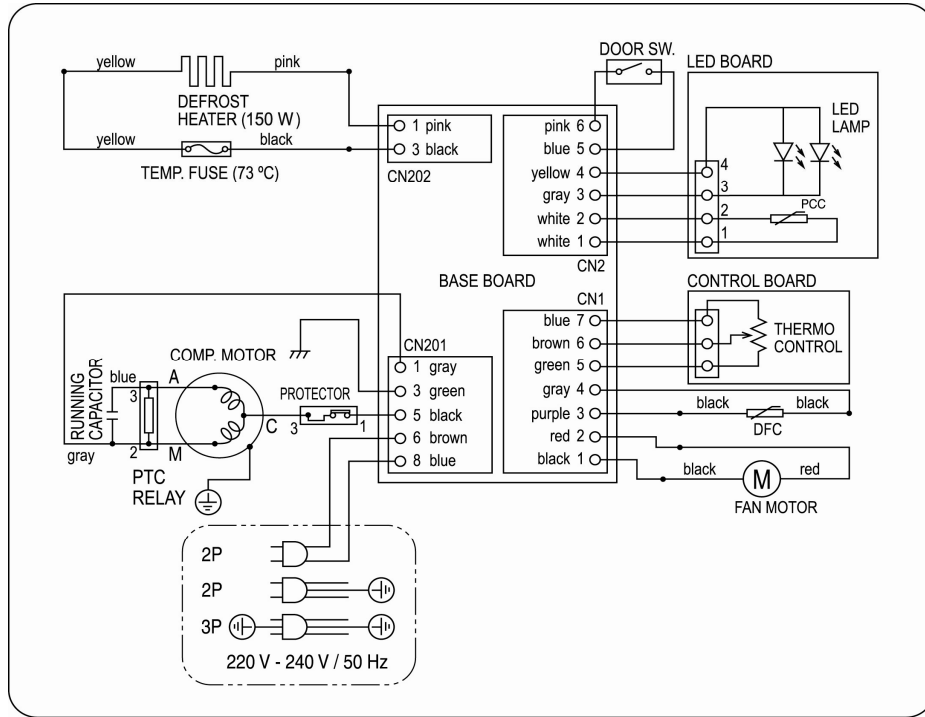

NR-BK306 SERIES NR-BK346 SERIES

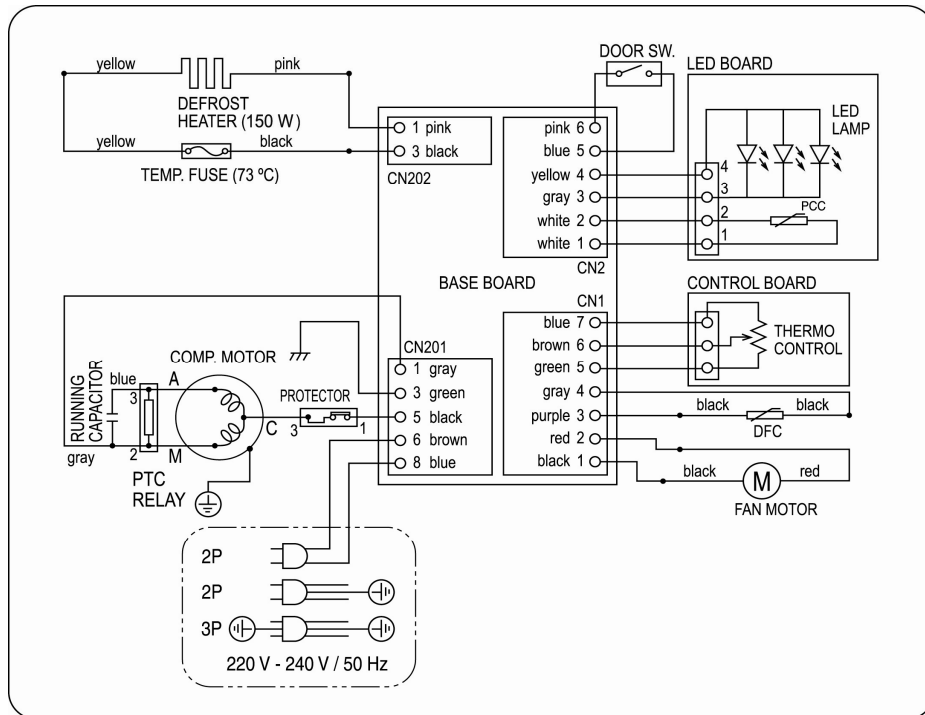

4. PERFORMANCE DATA

4.1 NR- BK266 SERIES

Control setting	FC	REFRIGE MAX	NORMAL	FREEZER MAX
	PC	"1"	"2"	"3"
Mean fresh food compartment	(°C)	5.0 ± 2.5	2.0 ± 2.5	1.0 ± 2.5
Mean freezer compartment	(°C)	-10.0 ± 2.5	-18.5 ± 2.5	-21.0 ± 2.5
FC door shelf	(°C)	-	-17.0 ± 2.5	-
Vegetable case	(°C)	-	3.0 ± 2.5	-
Tray egg	(°C)	-	7.5 ± 2.5	-
PC door shelf top	(°C)	-	5.0 ± 2.5	-
Chilled case	(°C)	-	-1.0 ± 2.5	-
Running ratio		40 ± 15	55 ± 15	65 ± 15

Under no-load condition and ambient temperature at 32°C ± 1°C

4.2 NR- BK306 SERIES

Control setting	FC	REFRIGE MAX	NORMAL	FREEZER MAX
	PC	"1"	"2"	"3"
Mean fresh food compartment	(°C)	5.0 ± 2.5	3.0 ± 2.5	2.0 ± 2.5
Mean freezer compartment	(°C)	-11.0 ± 2.5	-19.0 ± 2.5	-23.0 ± 2.5
FC door shelf	(°C)	-	-18.0 ± 2.5	-
Vegetable case	(°C)	-	5.0 ± 2.5	-
Tray egg	(°C)	-	7.5 ± 2.5	-
PC door shelf top	(°C)	-	5.0 ± 2.5	-
Chilled case	(°C)	-	-1.0 ± 2.5	-
Running ratio	%	40 ± 15	55 ± 15	75 ± 15

Under no-load condition and ambient temperature at 32°C ± 1°C

4.3 NR- BK346 SERIES

Control setting	FC	REFRIGE MAX	NORMAL	FREEZER MAX
	PC	"1"	"2"	"3"
Mean fresh food compartment	(°C)	5.0 ± 2.5	3.0 ± 2.5	2.0 ± 2.5
Mean freezer compartment	(°C)	-11.0 ± 2.5	-19.0 ± 2.5	-23.5 ± 2.5
FC door shelf	(°C)	-	-18.0 ± 2.5	-
Vegetable case	(°C)	-	5.0 ± 2.5	-
Tray egg	(°C)	-	7.5 ± 2.5	-
PC door shelf top	(°C)	-	5.0 ± 2.5	-
Chilled case	(°C)	-	0.5 ± 2.5	-
Running ratio		40 ± 15	55 ± 15	85 ± 15

Under no-load condition and ambient temperature at 32°C ± 1°C

5. TROUBLESHOOTING GUIDE

- Cause: Not cool or not enough cooling

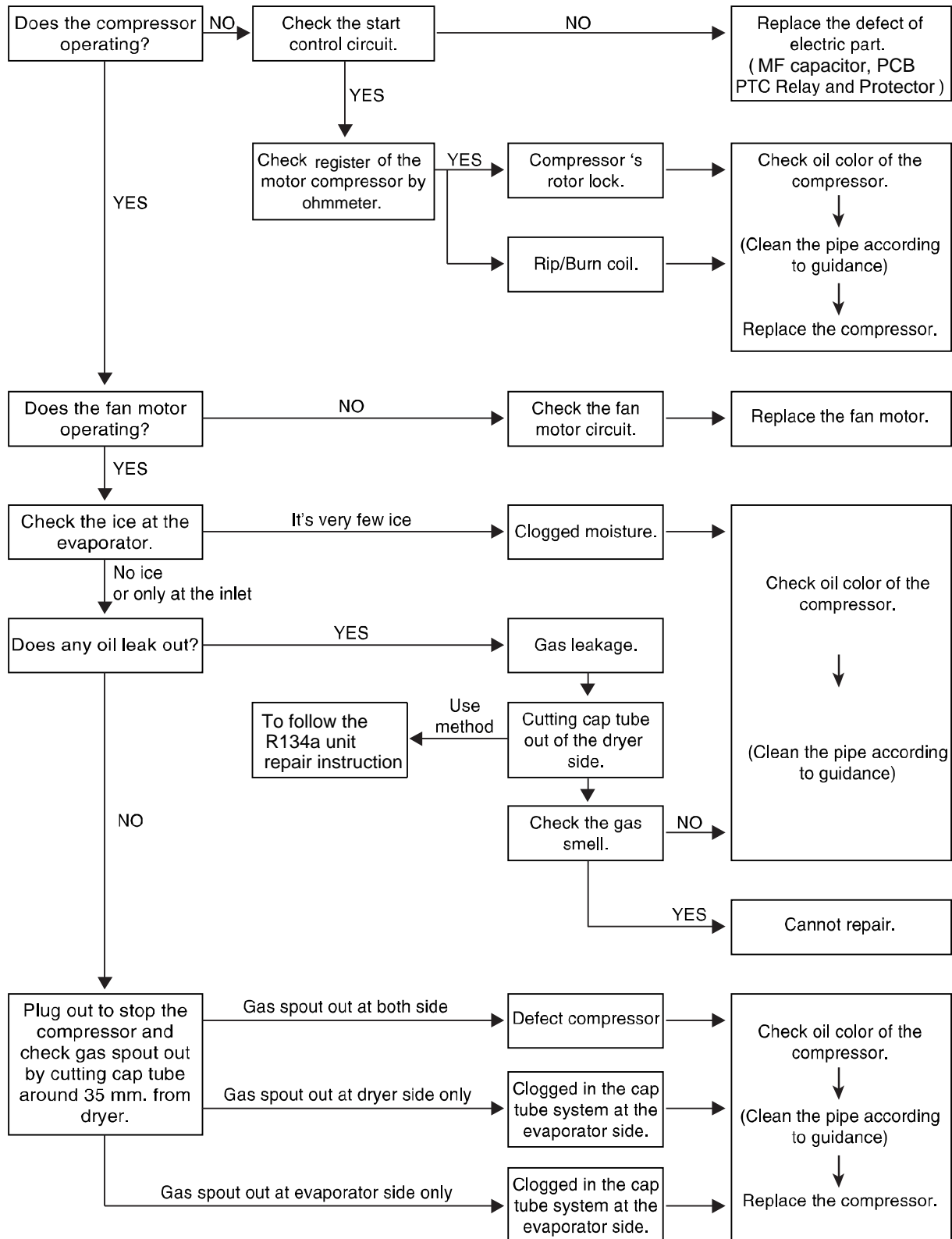

6. DISASSEMBLY INSTRUCTION

WITH MODEL NR-BK266 S SERIES, NR-BK306 SERIES, NR-BK346 SERIES

6.1. Freezer compartment

6.1.1. Remove cover coil:

1. Take out the ice cube tray and tray FC.
2. Use a small screw driver to open the cap of cover coil window.
3. The same way to open the cover of screw.
4. Unscrew 2 screws, then open the cover coil window.
5. Unscrew the third screw, then use pliers to cut tube bending.
6. Undo 4 connectors.
7. Remove the cover coil as show on the figure 7.

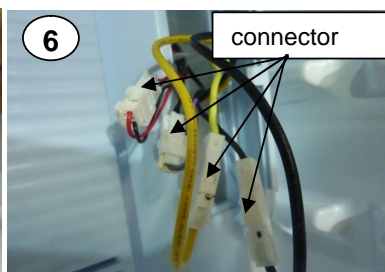
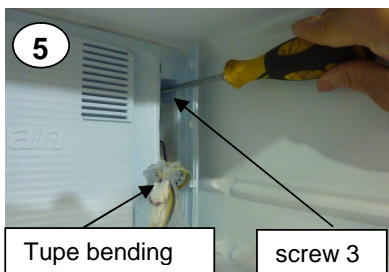
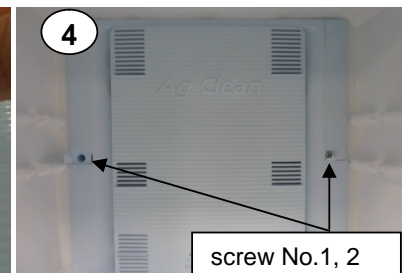
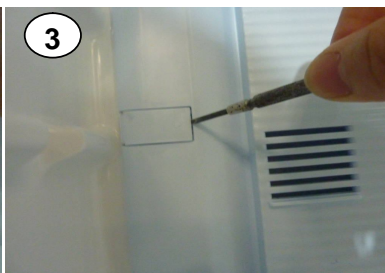
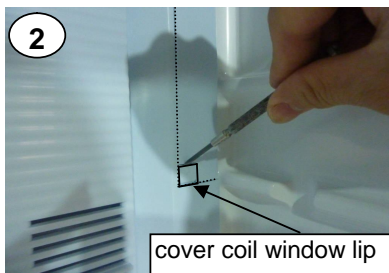

6.1.2. Sensor defrost, Temp. Fuse, Fan motor as

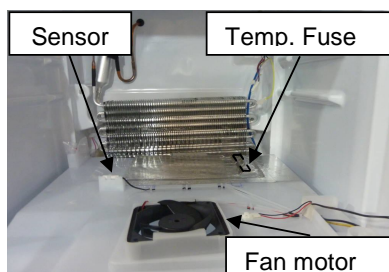

1. Take out sensor defrost.
2. Take off alumi tape 50 (mm), then remove Temp. Fuse.
3. Prise two hooks to remove Fan motor as.
4. Note: Be sure that connect terminal of connectors each other correctly when replacing Sensor, Temp. Fuse and Fan.

6.1.3. Defrost heater as

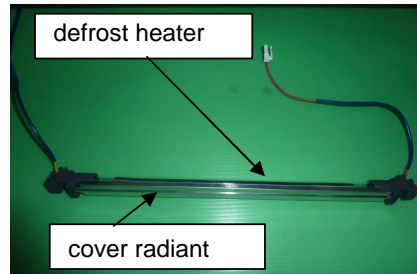
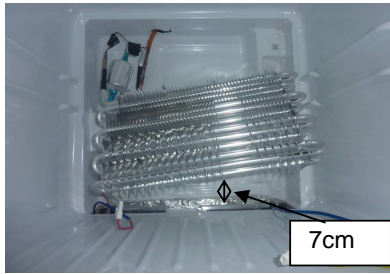

1. Bend the cooper tupe lightly, raise the coil about 7cm.
2. Bend the clamp lightly then take out defrost heater as.
3. Pull out the head of rubber lightly then take out cover radiant.

6.2. Provision compartment

6.2.1. Air guide



1. Take out all the tray, chilled case and crisper before remove the case air guide.
2. Unscrew, then remove the case air guide as follow the direction of arrow.
3. Pull out the air guide installation and remove the Ag filter bio as fig 3.

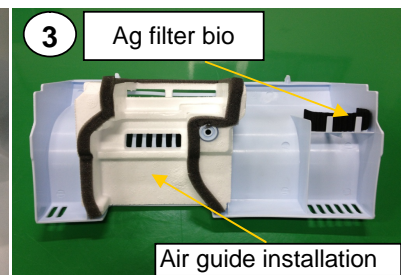
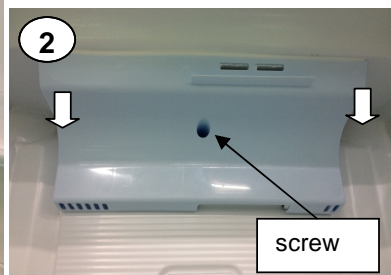

6.2.2. LED lamp

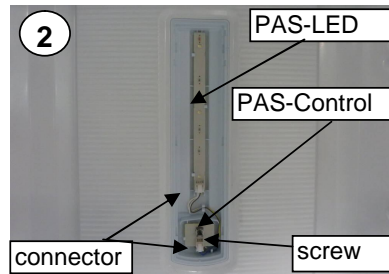
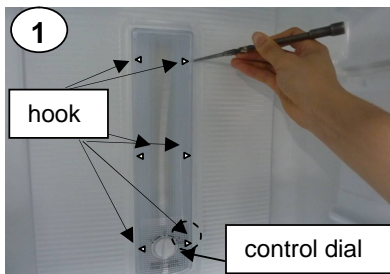

1. Use the slotted- small screw driver to unhook the LED cover follow 6 hooks on the fig 1.
2. Take out the control dial.
3. Unscrew, disconnect two connectors. Then can remove PAS- LED and PAS-control.

6.2.3. Door switch

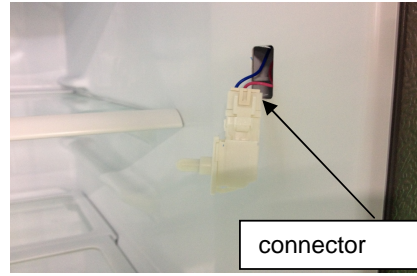

1. Push to the left then pull out door switch.
2. Pull down the door switch lightly, then undo connector.

6.3. Machine room

6.3.1. PCB, Supply cord & harness as wire main, MF capacitor, Relay, Motor protector

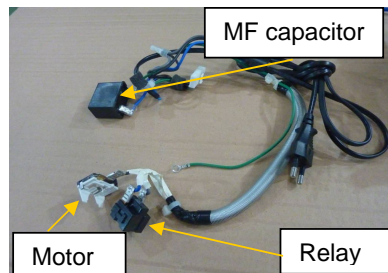
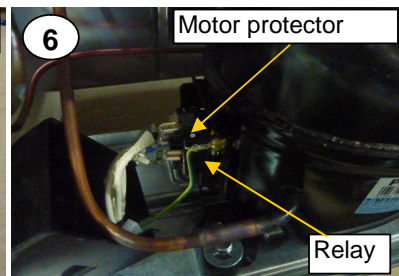
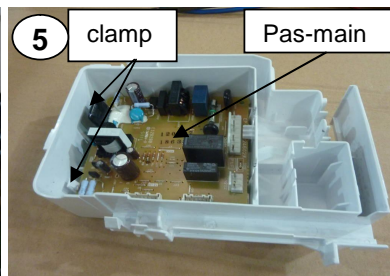
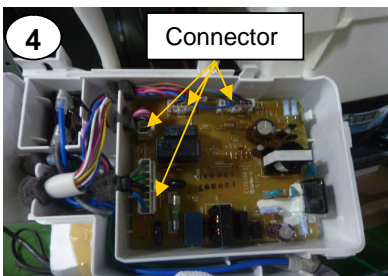
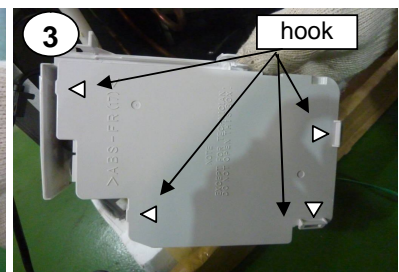
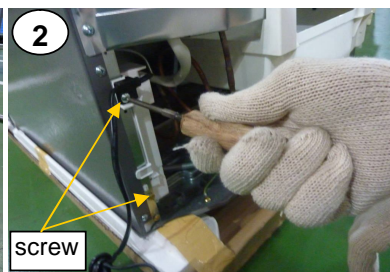
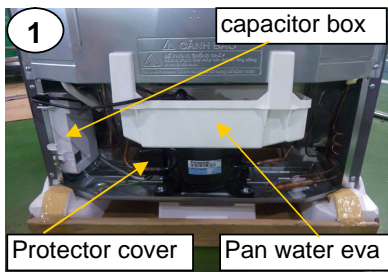

1. Remove the pan water eva.
2. Unscrew 2 screws.
3. Press on hooks to open the capacitor box.
4. Disconnect 4 connectors.
5. Push on two clamps to take out PAS-Main.
6. Remove the protector cover. Pull out PTC relay and motor protector from compressor.
7. Undo two claims with harness as wire main to take out Motor protector and PTC relay.

6.4. Replace FC, PC door

6.4.1. Replace FC door

Disassembly FC door

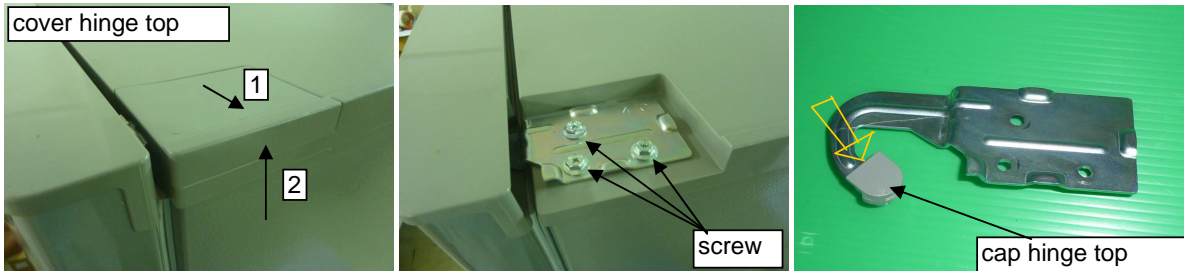

1. Close the FC door then remove cover hinge top:
 - Pull follow direction 1.
 - Push up follow direction 2.
2. Unscrew 3 screws, then lift up the FC door.
3. To remove the hinge top cap: push up then push out follow the direction of the arrow.

Assembly FC door



1. Apply grease to the areas of No. 1 & No. 2 of hinge center.
2. Put FC door : pin of hinge center fit to the hole of latch door.
3. Assembly hinge top: screw follow the order No.1, 2,3.

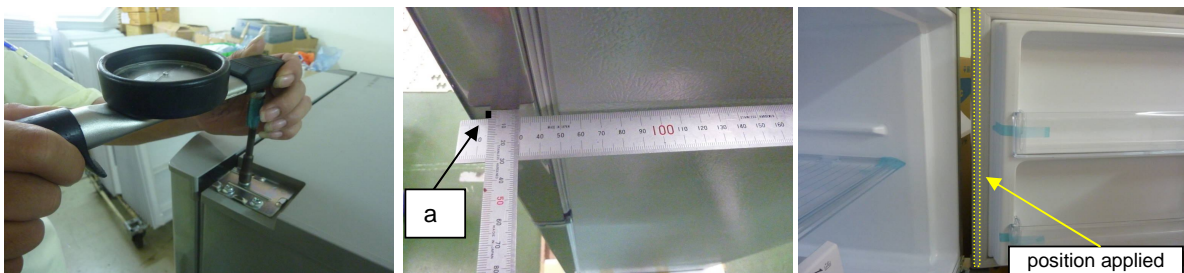

1. Use Torque driver to check force at screw 1, 2, 3 position. Standard is 600 ± 200 N.m. Then assembly cover hinge top.
2. Deviation between FC door and side of cabinet is $a \leq 1$ mm.
3. Apply grease to the line of gasket door FC as figure to avoid the twist of the gasket door.

6.4.2. Replace PC door

Disassembly PC door: FC door must be disassembled before the disassembly of the PC door.

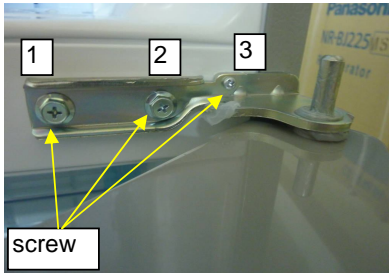

- Unscrew No. 1, 2, 3 of hinge center.
- Lift up the PC door.

Assembly PC door



1. Apply grease to the areas No. 1 & No. 2 of the hinge bottom.
2. Put PC door fit with hinge bottom .
3. Apply grease to the showed line of gasket door FC as figure to avoid the twist of the gasket door.
4. Screw of hinge center and check force at screw 1 and 2. Standard is 600 ± 200 cN.m

6. HƯỚNG DẪN THẢO LẮP

VỚI MODEL NR-BK266 S SERIES, NR-BK306 SERIES, NR-BK346 SERIES

6.1. Ngăn đá

6.1.1. Tháo cover coil:

1. Lấy khay đá và tray FC ra trước khi tháo cover coil.
2. Dùng tua vít nhỏ có cạnh sắc mở nắp đậy cửa sổ cover coil ra.
3. Cũng dùng tua vít nhỏ mở nắp đậy vít ra.
4. Tháo 2 vít, rồi mở cửa sổ cover coil.
5. Tháo vít số 3 như hình vẽ. Sau đó dùng kìm cắt dây thít.
6. Tháo 4 connector.
7. Gỡ cover coil ra như hình 7.

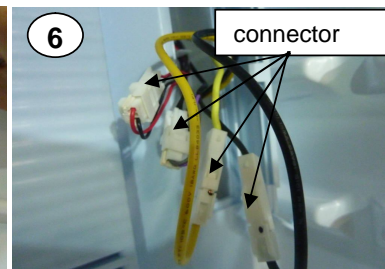
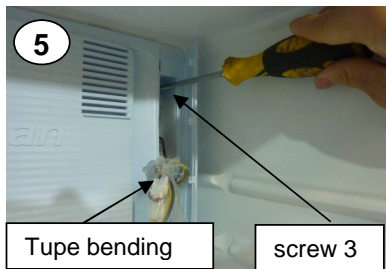
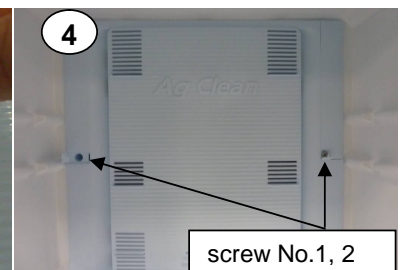
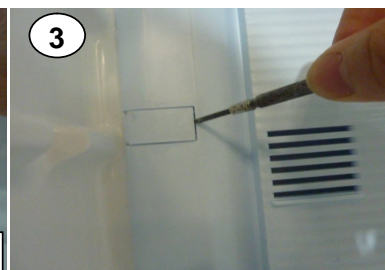
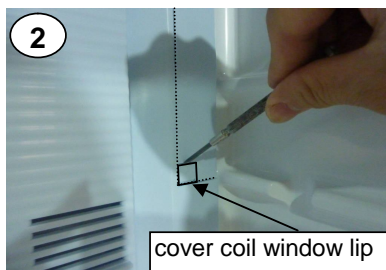

6.1.2. Sensor defrost, Temp. Fuse, Fan motor as

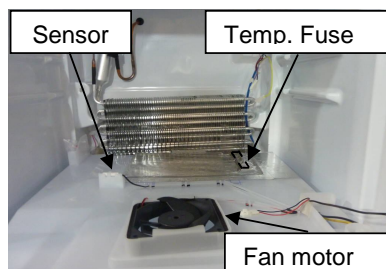

1. Tháo sensor defrost ra
2. Bóc alumi tape 50 (mm) ra, rồi tháo Temp. Fuse.
3. Bẫy vào hai lẫy nhựa để tháo Fan ra.
Chú ý: Khi thay thế Sensor, Temp. Fuse, và Fan phải kết nối đúng các đầu connector với nhau.

6.1.4. Tháo defrost heater as

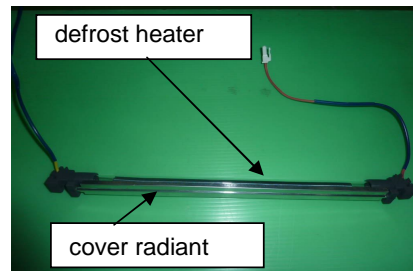
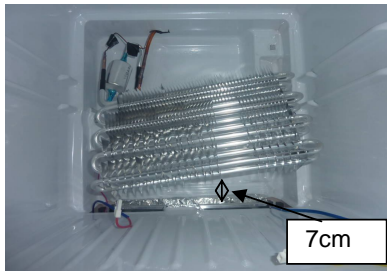

1. Uốn nhẹ ống đồng một chút, nâng nhẹ coil lên khoảng 7cm.
2. Bẻ nhẹ clamp ở hai đầu rồi nhấc defrost heater as ra.
3. Kéo nhẹ hai đầu cao su, nhấc cover radiant ra.

6.2. Ngăn thực phẩm

Lấy ra hết tray PC, chilled case, crisper và cover crisper.

6.2.1. Air guide



1. Lấy hết các tray, chilled case và khay đựng rau trong ngăn PC ra trước khi tháo case air guide.
2. Tháo vít như trên hình 2, rồi gỡ case air guide theo hướng mũi tên.
3. Tháo rời các bộ phận air guide lắp đặt, Ag filter bio như hình 3.

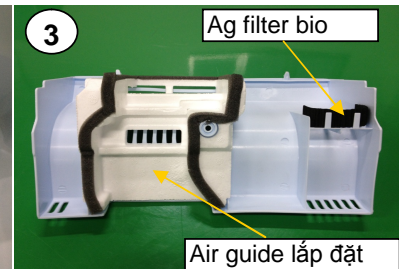
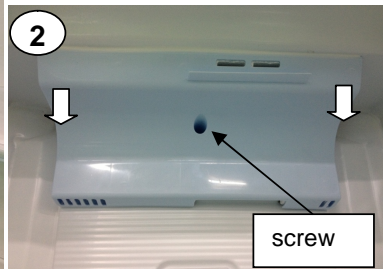

6.2.2. Đèn LED

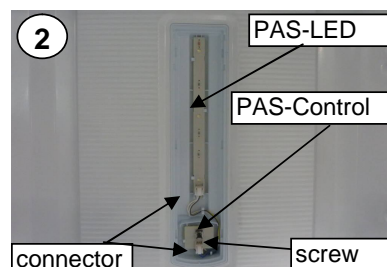
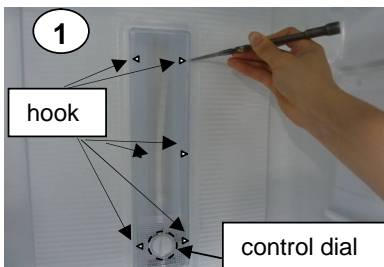

1. Dùng tua vít nhỏ có cạnh sắc tháo cover LED theo 6 lẫy như hình 1. Nhấc control dial ra.
2. Tháo vít, hai connector như hình 2. Sau đó gỡ PAS-LED và PAS-control.

6.2.3. Door switch

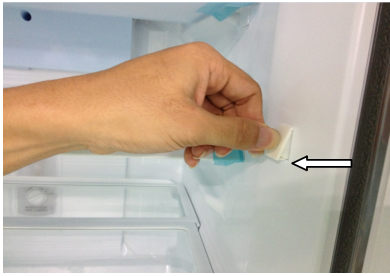

1. Đẩy sang trái một chút rồi kéo ra.

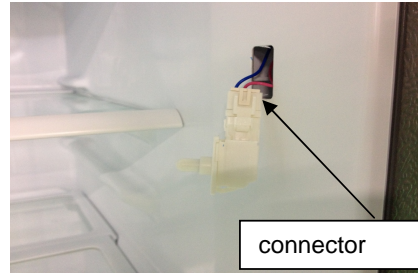

2. Kéo nhẹ door switch xuống, rồi tháo connector.

6.3. Machine room

6.3.1. Supply cord & harness as wire main, MF capacitor, Relay, motor protector

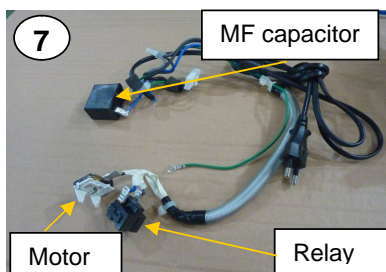
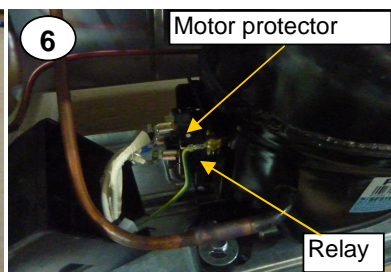
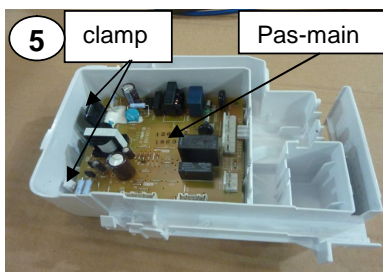
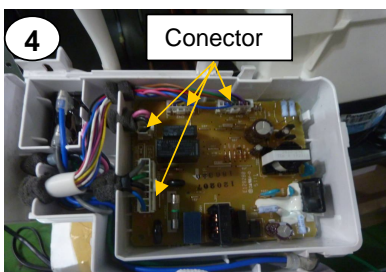
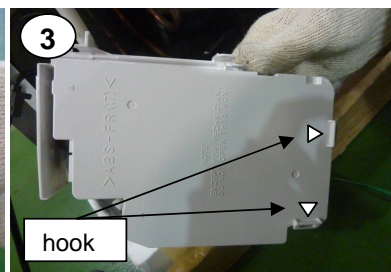
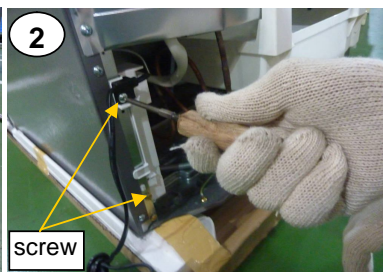
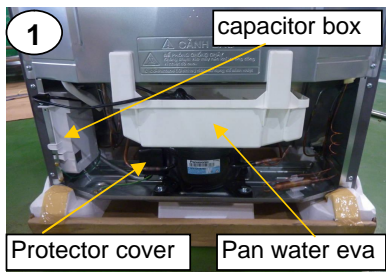

1. Gỡ pan water eva ra.
2. Để tháo capacitor box tháo 2 vít như hình 2.
3. Ấn vào 2 lẫy như hình 3 để mở capacitor box ra.
4. Tháo 4 connector.
5. Ấn vào hai lẫy để đưa PAS-main ra.
6. Gỡ protector cover ra. Rút relay và motor protector ra khỏi compressor.
7. Tháo rời hai kết nối với harness được wire main as, relay và motor protector.

6.4. Thay thế cánh FC, PC

6.4.1. Thay thế cánh FC

Tháo cánh FC

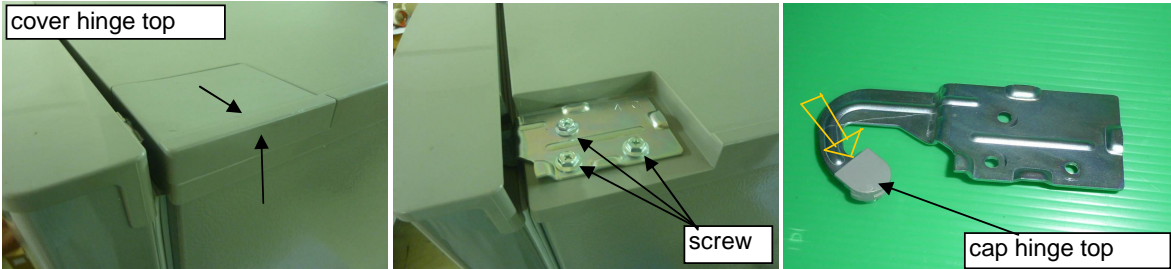

1. Đóng cánh FC lại. Sau đó tháo cover hinge top:
 - Đẩy sang ngang theo mũi tên.
 - Đẩy lên trên theo chiều mũi tên.
2. Tháo 3 vít, rồi nhấc cánh FC ra.
3. Tháo cap hinge top: đẩy lên và đẩy ra theo hướng mũi tên

Lắp cánh FC



1. Bôi mỡ vào vị trí 1 và 2 của hinge center.
2. Đặt cánh FC vào, chốt của hinge center phải khớp với lỗ của latch door.
3. Lắp hinge top: vặn 3 vít theo trình tự vít 1, 2 và 3.

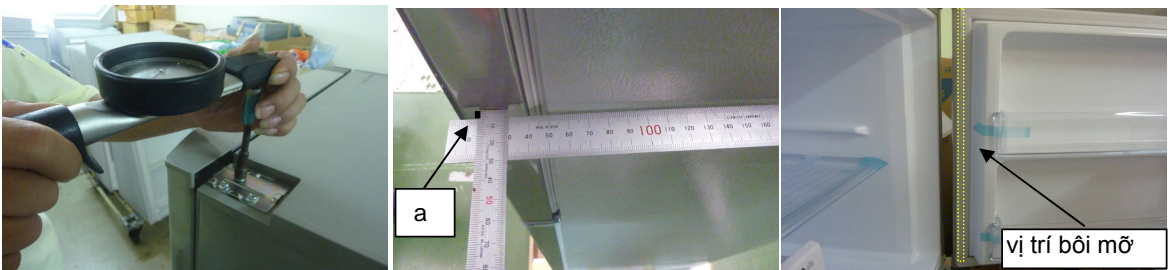

1. Dùng Torque driver kiểm tra lực tại 3 vị trí vít. Tiêu chuẩn $600 \pm 200 \text{cN.m}$.
2. Lắp cover hinge top. Độ lệch giữa cánh FC và hai thành side $a \leq 1 \text{mm}$.
3. Bôi mỡ đều vào đường góc giao nhau cửa để tránh kẹt.

6.4.2. Thay thế cánh PC

Tháo cánh PC: trước khi tháo cánh PC, thì phải tháo cánh FC.

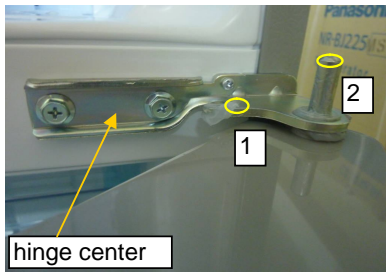

1. Tháo vít 1,2 của hinge center.
2. Nhấc cánh PC ra.

Lắp cánh PC



1. Trước khi lắp cánh PC, bôi mỡ vào vị trí 1,2.
2. Đặt cánh PC vào tương tự như cánh FC.
3. Bôi mỡ vào gioăng cửa như mô tả để tránh hiện tượng kẹt hoặc hở gioăng.
4. Lắp vít hinge center và kiểm tra lực vít tại 2 vị trí vít theo tiêu chuẩn.

7. PARTS EXPLODED VIEW AND REPLACEMENT PARTS LIST

7.1 Parts Exploded View : Body

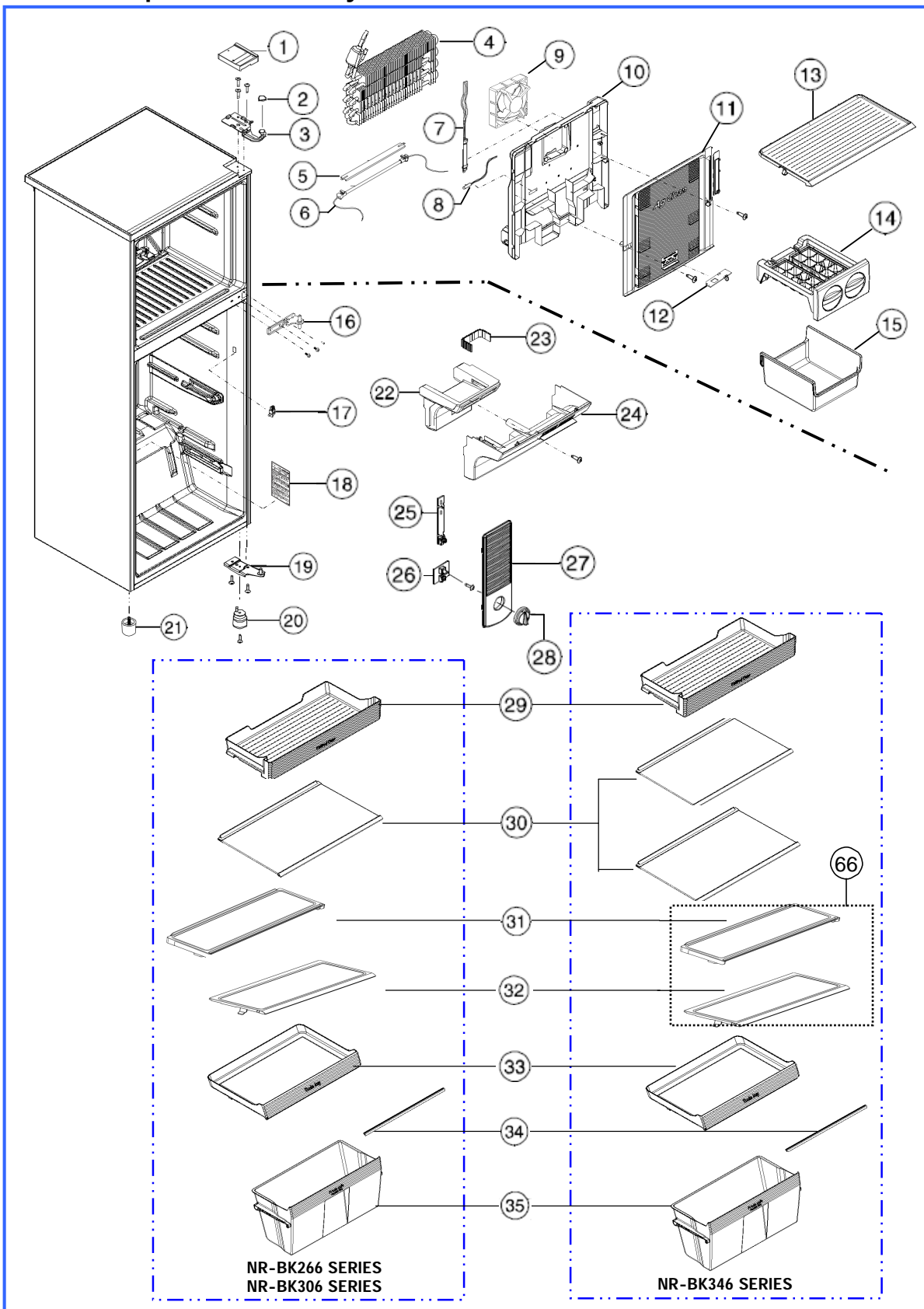

7.2 Parts Exploded View : Machine Room & Door

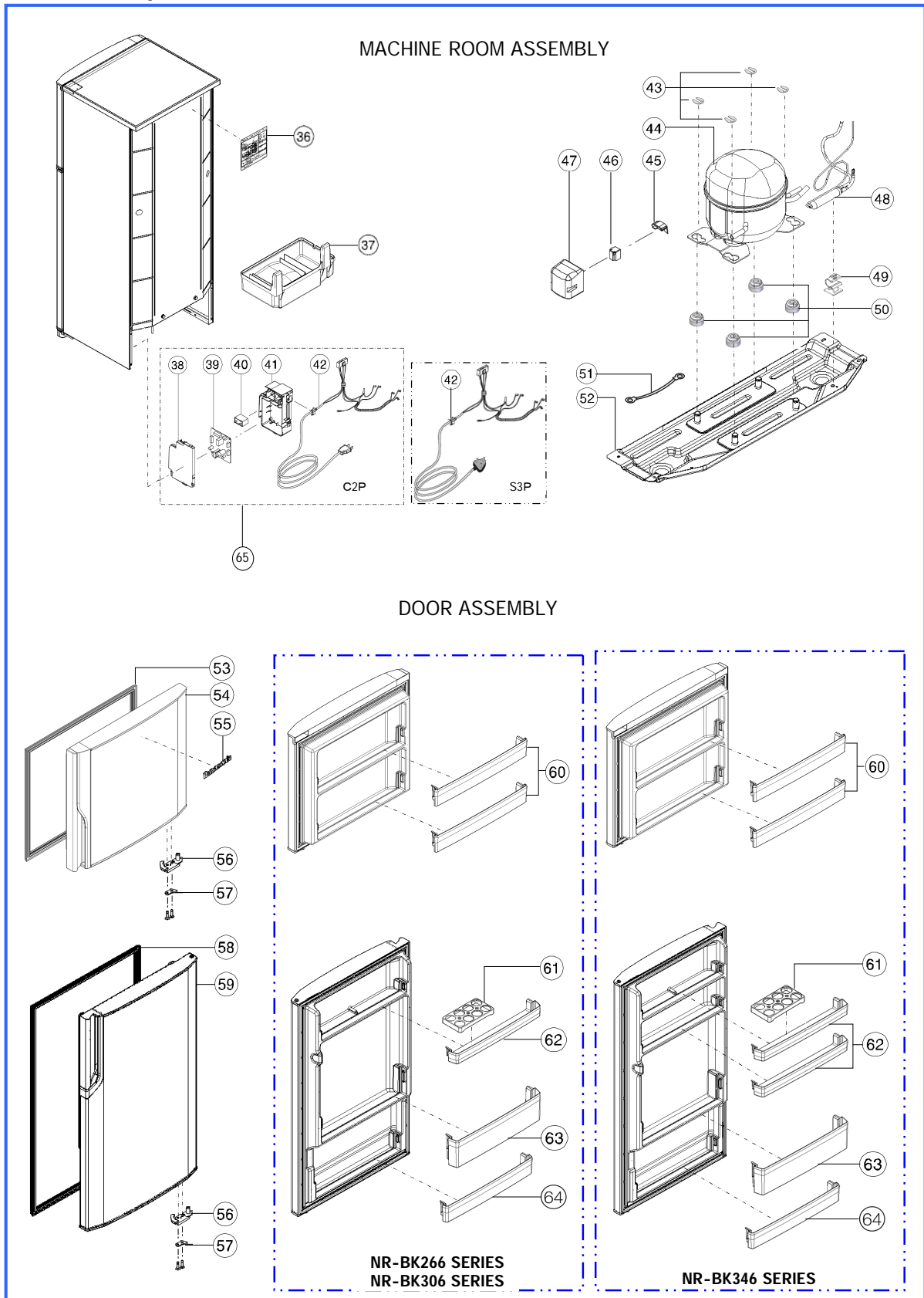

STEP 1

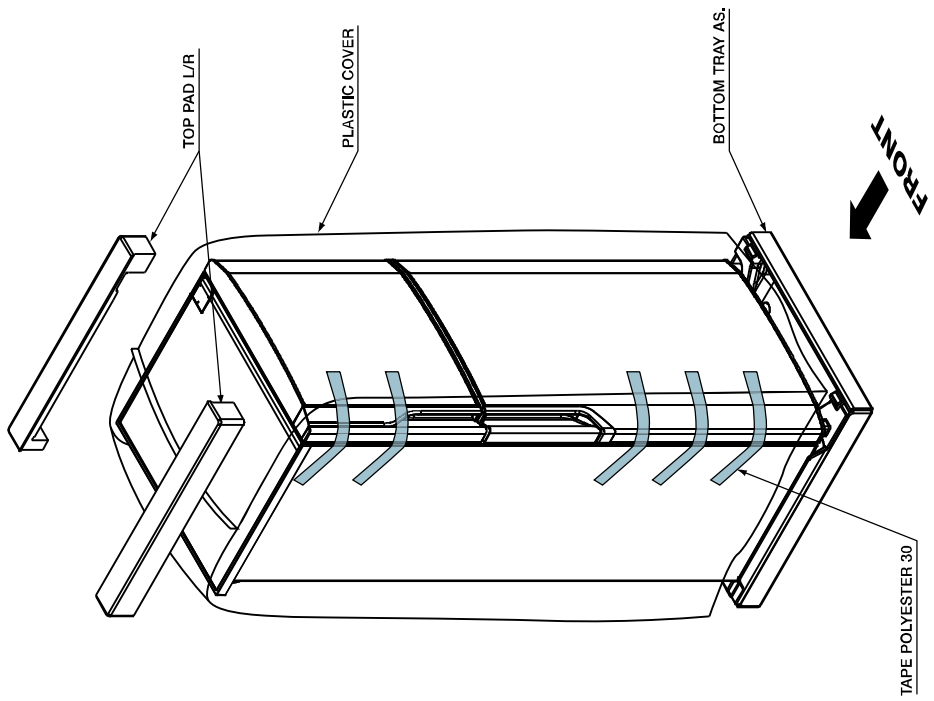

STEP 2

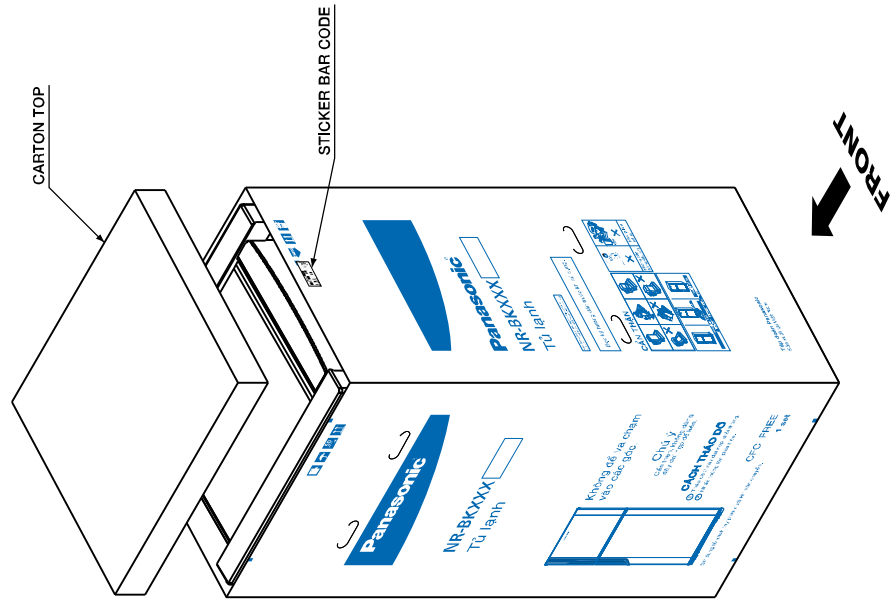

STEP 3



7.3 Part exploded view: Packing
FOR BK SERIES (VIETNAM)

STEP 1

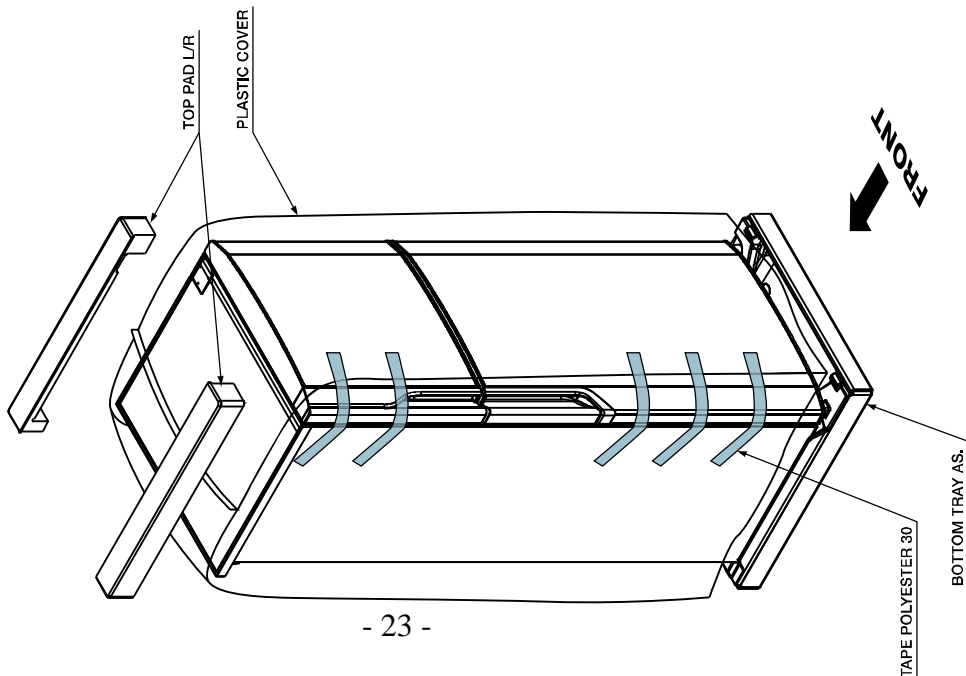

STEP 2

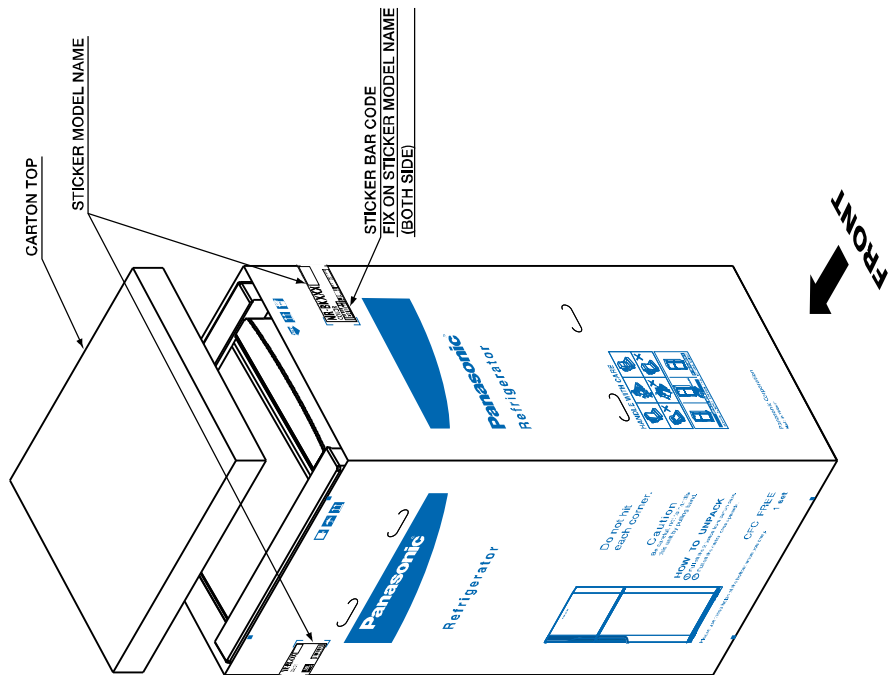

STEP 3



FOR BK SERIES (MALAYSIA, SIN-DBD, PGF, GULF)

STEP 1

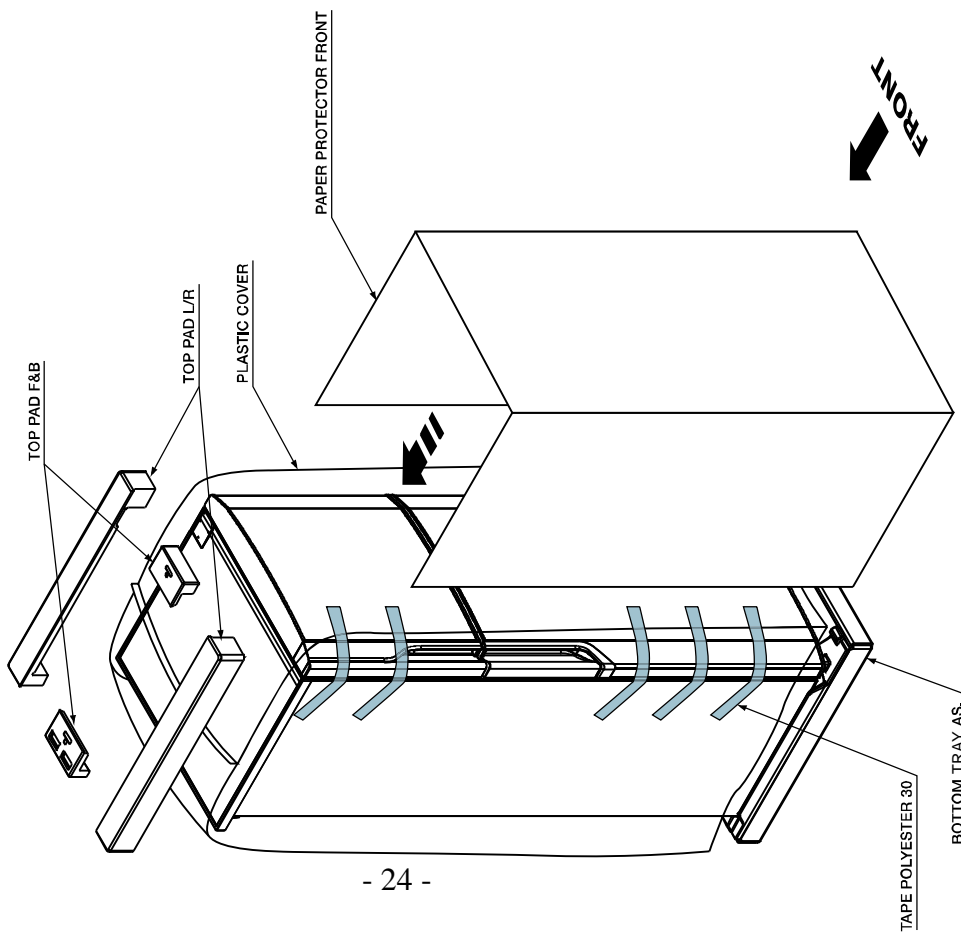

STEP 2

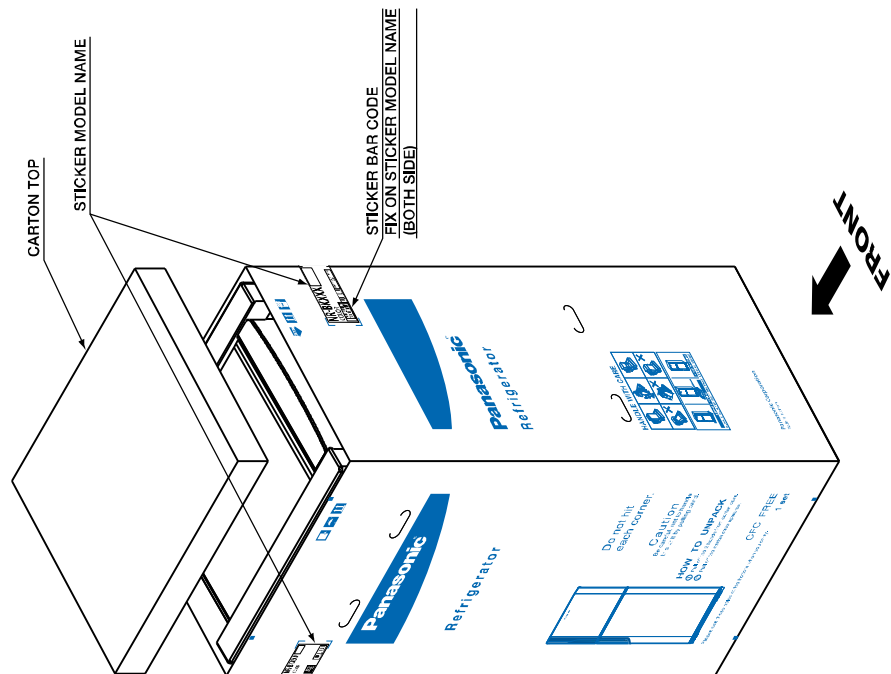

STEP 3

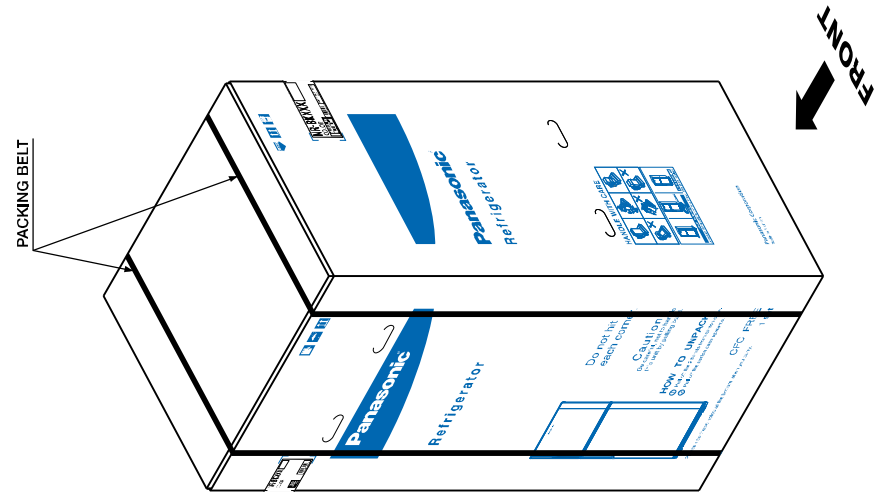

FOR BK SERIES (RBD, HONG KONG)

7.4 Replacement Part List : NR-BK266 SERIES

Parts List

Safety	Ref. No.	Part No.	Part Name	Model/Q' ty					Remark
				NR-BK266SN,MS,GS					
				Vietnam VN	RBD WA	Malaysia MY	Sin-DBD SG	Hong Kong HK	
	1	CNRAE-140782	COVER HINGE TOP-N	1	1		1	1	SN SERIES
		CNRAE-140792	COVER HINGE TOP-S	1	-	-	-	1	MS SERIES
	2	CNRAE-140801	CAP HINGE TOP	1	1	1	1	1	
S	3	CNRAE-140751	HINGE TOP	1	1	1	1	1	
	4	CNRAF-189550	COIL	1	1	1	1	1	
	5	CNRAG-170410	COVER RADIANT	1	1	1	1	1	
S	6	CNRAG-170400	HEATER AS. DEFROST	1	1	1	1	1	
S	7	CNRBG-181440	TEMP. FUSE AS.	1	1	1	1	1	
	8	CNRAG-168920	SENSOR DEFROST	1	1	1	1	1	
	9	CNRBG-182070	FAN MOTOR AS.	1	1	1	1	1	
	10	CNRAF-188520	COVER COIL BACK	1	1	1	1	1	
	11	CNRAF-188500	COVER COIL	1	1	1	1	1	
	12	CNRAF-188510	SHUTTER	1	1	1	1	1	
	13	CNRAH-295580	TRAY FC	1	1	1	1	1	
	14	CNRBH-145450	ICE CUBE TRAY AS.	1	1	1	1	1	
	15	CNRAH-295620	BOX ICE TRAY	1	1	1	1	1	
S	16	CNRAE-141290	HINGE CENTER	1	1	1	1	1	
	17	CNRAG-153290	DOOR SWITCH	1	1	1	1	1	
		CNRAH-315100	LABEL REF. BK266SNVN	1	-	-	-	-	SN SERIES
		CNRAH-315110	LABEL REF. BK266MSVN	1	-	-	-	-	MS SERIES
		CNRAH-316020	LABEL REF. BK266GSVN	1	-	-	-	-	GS SERIES
		CNRAH-315160	LABEL REF. BK266SNWA	-	1	-	-	-	SN SERIES
		CNRAH-315120	LABEL REF. BK266SNMY	-	-	1	-	-	SN SERIES
		CNRAH-315150	LABEL REF. BK266SNSG	-	-	-	1	-	SN SERIES
		CNRAH-316780	LABEL REF. BK266GSSG	-	-	-	1	-	GS SERIES
		CNRAH-315130	LABEL REF. BK266SNHK	-	-	-	-	1	SN SERIES
		CNRAH-315140	LABEL REF. BK266MSHK	-	-	-	-	1	MS SERIES
S	19	CNRAE-141200	HINGE BOTTOM	1	1	1	1	1	
	20	CNRAC-236050	LEG SHELL	1	1	1	1	1	
	21	CNRAC-221910	ADJUSTER BOLT	1	1	1	1	1	
	22	CNRAH-295570	INS. AIR GUIDE	1	1	1	1	1	
	23	CNRAG-245521	AG FILTER BIO	1	1	1	1	1	
	24	CNRAH-295560	CASE AIR GUIDE	1	1	1	1	1	
	25	CNRBG-182060	PAS-BJ175 (LED)	1	1	1	1	1	
	26	CNRBG-182050	PAS-BJ175 (CONTROL)	1	1	1	1	1	
	27	CNRAH-288351	COVER LED (BJ175)	1	1	1	1	1	
	28	CNRAH-288340	DIAL CONTROL	1	1	1	1	1	
	29	CNRAH-295630	CHILLED CASE	1	1	1	1	1	
	30	CNRBH-145460	GLASS TRAY PC AS.	1	1	1	1	1	
	31	CNRAH-312851	TRAY PCF BK6	1	1	1	1	1	
	32	CNRAH-312861	TRAY PCB BK6	1	1	1	1	1	
	33	CNRAH-295690	TRAY CRISPER	1	1	1	1	1	
	34	CNRAH-297190	SASH TRAY CRISPER	1	1	1	1	1	
	35	CNRAH-295700	CRISPER	1	1	1	1	1	
S		CNRAH-315170	LABEL NAME & WIRING D. BK266SNVN	1	-	-	-	-	SN SERIES
S		CNRAH-315180	LABEL NAME & WIRING D. BK266MSVN	1	-	-	-	-	MS SERIES
S		CNRAH-316030	LABEL NAME & WIRING D. BK266GSVN	1	-	-	-	-	GS SERIES
S		CNRAH-315230	LABEL NAME & WIRING D. BK266SNWA	-	1	-	-	-	SN SERIES
S	36	CNRAH-315190	LABEL NAME & WIRING D. BK266SNMY	-	-	1	-	-	SN SERIES
S		CNRAH-315220	LABEL NAME & WIRING D. BK266SNSG	-	-	-	1	-	SN SERIES
S		CNRAH-316870	LABEL NAME & WIRING D. BK266GSSG	-	-	-	1	-	GS SERIES
S		CNRAH-315200	LABEL NAME & WIRING D. BK266SNHK	-	-	-	-	1	SN SERIES
S		CNRAH-315210	LABEL NAME & WIRING D. BK266MSHK	-	-	-	-	1	MS SERIES
	37	CNRAF-189660	PAN WATER EVA.	1	1	1	1	1	
	38	CNRAG-169330	COVER BOX CAPACITOR	1	1	1	1	1	
	39	CNRBG-186320	PAS-BK305S (MAIN)	1	1	1	1	1	
	40	CNRAG-153360	MF. CAPACITOR	1	1	1	1	1	
	41	CNRAG-169320	BOX CAPACITOR	1	1	1	1	1	
S	42	CNRBG-187050	SUPPLY CORD & HARNESS	1	1	-	-	-	C2P
S		CNRBG-184560	WIRE MAIN	-	-	1	1	1	S3P
	43	CNRAJ-162500	U-RING WASHER	4	4	4	4	4	
	44	CNR91-105480	COMPRESSOR	1	1	1	1	1	
S	45	CNR06-598100	MOTOR PROTECTOR	1	1	1	1	1	
S	46	CNR06-592700	PTC. RELAY	1	1	1	1	1	
	47	CNRGD-036540	COVER PROTECTOR	1	1	1	1	1	
	48	CNR39-340920	5 GRAM DRYER W	1	1	1	1	1	
	49	CNR39-163082	CLAMPER DRYER	1	1	1	1	1	
	50	CNR01-219932	RUBBER GROMMET	4	4	4	4	4	

Parts List

Safety	Ref. No.	Part No.	Part Name	Model/Q' ty					Remark
				NR-BK266SN,MS,GS					
				Vietnam	RBD	Malaysia	Sin-DBD	Hong Kong	
VN	WA	MY	SG	HK					
	51	CNRBG-179830	EARTH AS. COMP. 180	1	1	1	1	1	
	52	CNRBF-159520	CROSSRAIL REAR As.	1	1	1	1	1	
	53	CNRAD-358960	GASKET DOOR FC	1	1	1	1	1	
	54	CNRBD-372010	DOOR AS. FC (FOAM) N	1	1	1	1	1	SN SERIES
		CNRBD-393510	DOOR AS. FC (FOAM) MS BK6	1	-	-	-	1	MS SERIES
		CNRBD-393520	DOOR AS. FC (FOAM) GS BK6	1	-	-	1	-	GS SERIES
	55	CNRAD-339801	EMBLEM (Panasonic logo)	1	1	1	1	1	
	56	CNRAD-156574	LATCH DOOR	2	2	2	2	2	
	57	CNRAD-354010	STOPPER DOOR	2	2	2	2	2	
	58	CNRAD-359240	GASKET DOOR PC	1	1	1	1	1	SN SERIES
	59	CNRBD-372100	DOOR AS. PC (FOAM) SN	1	1	1	1	1	MS SERIES
		CNRBD-393640	DOOR AS. PC (FOAM) MS BK266	1	-	-	-	1	GS SERIES
		CNRBD-393790	DOOR AS. PC (FOAM) GS BK266	1	-	-	1	-	
	60	CNRAD-361440	SHELF FC	2	2	2	2	2	
	61	CNRAD-323180	TRAY EGG 8	1	1	1	1	1	
	62	CNRAD-359100	SHELF EGG	1	1	1	1	1	
	63	CNRAD-359110	SHELF BOTTLE	1	1	1	1	1	
	64	CNRAD-359120	SHELF BOTTLE S	1	1	1	1	1	
	65	CNRBG-187060	BOX CAPACITOR AS.	1	1	-	-	-	C2P
		CNRBG-184530		-	-	1	1	1	S3P
	66	CNRBH-147650	SLIDE GLASS TRAY PC AS. BK6	1	1	1	1	1	

Packing List

Ref. No.	Part No.	Part Name	Model/Q' ty					Remark
			NR-BK266SN,MS,GS					
			Vietnam	RBD	Malaysia	Sin-DBD	Hong Kong	
VN	WA	MY	SG	HK				
	CNRAK-158640	CARTON TOP	1	1	1	1	1	
	CNRBK-128470	TOP PAD AS.	1	1	1	1	1	
	CNRBK-128480	TOP PAD F/B AS.	-	1	-	-	1	
	CNRBK-128150	BOTTOM TRAY AS.	1	1	1	1	1	
	CNRAJ-151650	PLASTIC COVER	1	1	1	1	1	
	CNRAK-158660	INS PAD COMP.	1	1	1	1	1	
	CNRAK-170510	INSTRUCTION BOOK VN (VN)	1	-	-	-	-	
	CNRAK-170550	INSTRUCTION BOOK (RBD/ARB/PER)	-	1	-	-	-	
	CNRAK-170520	INSTRUCTION BOOK (MAL/ENG/CHI)	-	-	1	-	-	
	CNRAK-170540	INSTRUCTION BOOK-SG (ENG/CHI)	-	-	-	1	-	
	CNRAK-170530	INSTRUCTION BOOK-HK (CHI/ENG)	-	-	-	-	1	
	CNRBK-136610	PACKING AS. BK266SNVN	1	-	-	-	-	SN SERIES
	CNRBK-136620	PACKING AS. BK266MSVN	1	-	-	-	-	MS SERIES
	CNRBK-136950	PACKING AS. BK266GSVN	1	-	-	-	-	GS SERIES
	CNRBK-136670	PACKING AS. BK266SNWA	-	1	-	-	-	SN SERIES
	CNRBK-136630	PACKING AS. BK266SNMY	-	-	1	-	-	SN SERIES
	CNRBK-136660	PACKING AS. BK266SNSG	-	-	-	1	-	SN SERIES
	CNRBK-137420	PACKING AS. BK266GSSG	-	-	-	1	-	GS SERIES
	CNRBK-136640	PACKING AS. BK266SNHK	-	-	-	-	1	SN SERIES
	CNRBK-136650	PACKING AS. BK266MSHK	-	-	-	-	1	MS SERIES
	CNRAK-158730	PAPER PROTECTOR FRONT BK265	-	1	-	-	1	

7.5 Replacement Part List : NR-BK306 SERIES

Parts List

Safety	Ref. No.	Part No.	Part Name	Model/Q'ty							Remark
				NR-BK306SN,MS,GS							
				Vietnam VN	RBD WA	Malaysia MY	Sin-DBD SG	Hong Kong HK	PGF WG	GULF AE	
	1	CNRAE-140782	COVER HINGE TOP-N	1	1	1	1	1	1	1	SN SERIES
		CNRAE-140792	COVER HINGE TOP-S	1	-	1	-	1	-	-	MS SERIES
	2	CNRAE-140801	CAP HINGE TOP	1	1	1	1	1	1	1	
S	3	CNRAE-140751	HINGE TOP	1	1	1	1	1	1	1	
	4	CNRAF-189550	COIL	1	1	1	1	1	1	1	
	5	CNRAG-170410	COVER RADIANT	1	1	1	1	1	1	1	
S	6	CNRAG-170400	HEATER AS. DEFROST	1	1	1	1	1	1	1	
S	7	CNRBG-181440	TEMP. FUSE AS.	1	1	1	1	1	1	1	
	8	CNRAG-168920	SENSOR DEFROST	1	1	1	1	1	1	1	
	9	CNRBG-182070	FAN MOTOR AS.	1	1	1	1	1	1	1	
	10	CNRAF-188520	COVER COIL BACK	1	1	1	1	1	1	1	
	11	CNRAF-188500	COVER COIL	1	1	1	1	1	1	1	
	12	CNRAF-188510	SHUTTER	1	1	1	1	1	1	1	
	13	CNRAH-295580	TRAY FC	1	1	1	1	1	1	1	
	14	CNRBH-145450	ICE CUBE TRAY AS.	1	1	1	1	1	1	1	
	15	CNRAH-295620	BOX ICE TRAY	1	1	1	1	1	1	1	
S	16	CNRAE-141290	HINGE CENTER	1	1	1	1	1	1	1	
	17	CNRAG-153290	DOOR SWITCH	1	1	1	1	1	1	1	
		CNRAH-314660	LABEL REF. BK306SNVN	1	-	-	-	-	-	-	SN SERIES
		CNRAH-314670	LABEL REF. BK306MSVN	1	-	-	-	-	-	-	MS SERIES
		CNRAH-314680	LABEL REF. BK306GSVN	1	-	-	-	-	-	-	GS SERIES
		CNRAH-314740	LABEL REF. BK306SNWA	-	1	-	-	-	-	-	SN SERIES
		CNRAH-314690	LABEL REF. BK306SNMY	-	-	1	-	-	-	-	SN SERIES
		CNRAH-314700	LABEL REF. BK306MSMY	-	-	1	-	-	-	-	MS SERIES
		CNRAH-314730	LABEL REF. BK306SNSG	-	-	-	1	-	-	-	SN SERIES
		CNRAH-316790	LABEL REF. BK306GSSG	-	-	-	1	-	-	-	GS SERIES
		CNRAH-314710	LABEL REF. BK306SNHK	-	-	-	-	1	-	-	SN SERIES
		CNRAH-314720	LABEL REF. BK306MSHK	-	-	-	-	1	-	-	MS SERIES
		CNRAH-314760	LABEL REF. BK306SNWG	-	-	-	-	-	1	-	SN SERIES
		CNRAH-314750	LABEL REF. BK306SNAE	-	-	-	-	-	-	1	SN SERIES
S	19	CNRAE-141200	HINGE BOTTOM	1	1	1	1	1	1	1	
	20	CNRAC-236050	LEG SHELL	1	1	1	1	1	1	1	
	21	CNRAC-221910	ADJUSTER BOLT	1	1	1	1	1	1	1	
	22	CNRAH-295570	INS. AIR GUIDE	1	1	1	1	1	1	1	
	23	CNRAG-245521	AG FILTER BIO	1	1	1	1	1	1	1	
	24	CNRAH-295560	CASE AIR GUIDE	1	1	1	1	1	1	1	
	25	CNRBG-184500	PAS-BK305 (LED)	1	1	1	1	1	1	1	
	26	CNRBG-182050	PAS-BJ175 (CONTROL)	1	1	1	1	1	1	1	
	27	CNRAH-295550	COVER LED	1	1	1	1	1	1	1	
	28	CNRAH-288340	DIAL CONTROL	1	1	1	1	1	1	1	
	29	CNRAH-295630	CHILLED CASE	1	1	1	1	1	1	1	
	30	CNRBH-145460	GLASS TRAY PC AS.	1	1	1	1	1	1	1	
	31	CNRAH-312851	TRAY PCF BK6	1	1	1	1	1	1	1	
	32	CNRAH-312861	TRAY PCB BK6	1	1	1	1	1	1	1	
	33	CNRAH-295690	TRAY CRISPER	1	1	1	1	1	1	1	
	34	CNRAH-297190	SASH TRAY CRISPER	1	1	1	1	1	1	1	
	35	CNRAH-295700	CRISPER	1	1	1	1	1	1	1	
S		CNRAH-314770	LABEL NAME & WIRING D. BK306SNVN	1	-	-	-	-	-	-	SN SERIES
S		CNRAH-314780	LABEL NAME & WIRING D. BK306MSVN	1	-	-	-	-	-	-	MS SERIES
S		CNRAH-314790	LABEL NAME & WIRING D. BK306GSVN	1	-	-	-	-	-	-	GS SERIES
S		CNRAH-314850	LABEL NAME & WIRING D. BK306SNWA	-	1	-	-	-	-	-	SN SERIES
S		CNRAH-314800	LABEL NAME & WIRING D. BK306SNMY	-	-	1	-	-	-	-	SN SERIES
S		CNRAH-314810	LABEL NAME & WIRING D. BK306MSMY	-	-	1	-	-	-	-	MS SERIES
S		CNRAH-314840	LABEL NAME & WIRING D. BK306SNSG	-	-	-	1	-	-	-	SN SERIES
S		CNRAH-316880	LABEL NAME & WIRING D. BK306GSSG	-	-	-	1	-	-	-	GS SERIES
S		CNRAH-314820	LABEL NAME & WIRING D. BK306SNHK	-	-	-	-	1	-	-	SN SERIES
S		CNRAH-314830	LABEL NAME & WIRING D. BK306MSHK	-	-	-	-	1	-	-	MS SERIES
S		CNRAH-314870	LABEL NAME & WIRING D. BK306SNWG	-	-	-	-	-	1	-	SN SERIES
S		CNRAH-314860	LABEL NAME & WIRING D. BK306SNAE	-	-	-	-	-	-	1	SN SERIES
	37	CNRAF-189660	PAN WATER EVA.	1	1	1	1	1	1	1	
	38	CNRAG-169330	COVER BOX CAPACITOR	1	1	1	1	1	1	1	
	39	CNRBG-186320	PAS-BK305S (MAIN)	1	1	1	1	1	1	1	
	40	CNRAG-153360	MF. CAPACITOR	1	1	1	1	1	1	1	
	41	CNRAG-169320	BOX CAPACITOR	1	1	1	1	1	1	1	
S		CNRBG-187050	SUPPLY CORD & HARNESS	1	1	-	-	-	-	-	C2P
S	42	CNRBG-184560	WIRE MAIN	-	-	1	1	1	-	1	S3P
S		CNRBG-184580		-	-	-	-	-	1	-	C2P(SHUKO)
	43	CNRAJ-162500	U-RING WASHER	4	4	4	4	4	4	4	
	44	CNR91-105480	COMPRESSOR	1	1	1	1	1	1	1	
S	45	CNR06-598100	MOTOR PROTECTOR	1	1	1	1	1	1	1	
S	46	CNR06-592700	PTC. RELAY	1	1	1	1	1	1	1	
	47	CNRGD-036540	COVER PROTECTOR	1	1	1	1	1	1	1	
	48	CNR39-340920	5 GRAM DRYER W	1	1	1	1	1	1	1	
	49	CNR39-163082	CLAMPER DRYER	1	1	1	1	1	1	1	
	50	CNR01-219932	RUBBER GROMMET	4	4	4	4	4	4	4	

Parts List

Safety	Ref. No.	Part No.	Part Name	Model/Q' ty						Remark	
				NR-BK306SN,MS,GS							
				Vietnam VN	RBD WA	Malaysia MY	Sin-DBD SG	Hong Kong HK	PGF WG		GULF AE
	51	CNRBG-179830	EARTH AS. COMP. 180	1	1	1	1	1	1	1	
	52	CNRBF-159520	CROSSRAIL REAR AS.	1	1	1	1	1	1	1	
	53	CNRAD-358960	GASKET DOOR FC	1	1	1	1	1	1	1	
		CNRBD-372010	DOOR AS. FC (FOAM) N	1	1	1	1	1	1	1	SN SERIES
	54	CNRBD-393510	DOOR AS. FC (FOAM) MS BK6	1	-	-	-	-	-	-	MS SERIES
		CNRBD-393520	DOOR AS. FC (FOAM) GS BK6	1	-	-	1	-	-	-	GS SERIES
	55	CNRAD-339801	EMBLEM (Panasonic logo)	1	1	1	1	1	1	1	
	56	CNRAD-156574	LATCH DOOR	2	2	2	2	2	2	2	
	57	CNRAD-354010	STOPPER DOOR	2	2	2	2	2	2	2	
	58	CNRAD-359090	GASKET DOOR PC	1	1	1	1	1	1	1	
		CNRBD-372050	DOOR AS. PC (FOAM) SN	1	1	1	1	1	1	1	SN SERIES
	59	CNRBD-393580	DOOR AS. PC (FOAM) MS BK306	1	-	1	-	1	-	-	MS SERIES
		CNRBD-393590	DOOR AS. PC (FOAM) GS BK306	1	-	-	1	-	-	-	GS SERIES
	60	CNRAD-361440	SHELF FC	2	2	2	2	2	2	2	
	61	CNRAD-323180	TRAY EGG 8	1	1	1	1	1	1	1	
	62	CNRAD-359100	SHELF EGG	1	1	1	1	1	1	1	
	63	CNRAD-359110	SHELF BOTTLE	1	1	1	1	1	1	1	
	64	CNRAD-359120	SHELF BOTTLE S	1	1	1	1	1	1	1	
		CNRBG-187060	BOX CAPACITOR AS.	1	1	-	-	-	-	-	C2P
	65	CNRBG-184530		-	-	1	1	1	-	1	S3P
		CNRBG-184540		-	-	-	-	-	1	-	C2P(SHUKO)
	66	CNRBH-147650	SLIDE GLASS TRAY PC AS. BK	1	1	1	1	1	1	1	

Packing List

Ref. No.	Part No.	Part Name	Model/Q' ty						Remark	
			NR-BK306SN,MS,GS							
			Vietnam VN	RBD WA	Malaysia MY	Sin-DBD SG	Hong Kong HK	PGF WG		GULF AE
	CNRAK-158640	CARTON TOP	1	1	1	1	1	1	1	
	CNRBK-128470	TOP PAD AS.	1	1	1	1	1	1	1	
	CNRBK-128480	TOP PAD F/B AS.	-	1	-	-	1	-	-	
	CNRBK-128150	BOTTOM TRAY AS.	1	1	1	1	1	1	1	
	CNRAJ-151650	PLASTIC COVER	1	1	1	1	1	1	1	
	CNRAK-158660	INS PAD COMP.	1	1	1	1	1	1	1	
	CNRAK-170510	INSTRUCTION BOOK VN (VN)	1	-	-	-	-	-	-	
	CNRAK-170550	INSTRUCTION BOOK (RBD/ARB/PER)	-	1	-	-	-	1	1	
	CNRAK-170520	INSTRUCTION BOOK (MAL/ENG/CHI)	-	-	1	-	-	-	-	
	CNRAK-170540	INSTRUCTION BOOK-SG (ENG/CHI)	-	-	-	1	-	-	-	
	CNRAK-170530	INSTRUCTION BOOK-HK (CHI/ENG)	-	-	-	-	1	-	-	
	CNRBK-136430	PACKING AS. BK306SNVN	1	-	-	-	-	-	-	SN SERIES
	CNRBK-136440	PACKING AS. BK306MSVN	1	-	-	-	-	-	-	MS SERIES
	CNRBK-136450	PACKING AS. BK306GSVN	1	-	-	-	-	-	-	GS SERIES
	CNRBK-136510	PACKING AS. BK306SNWA	-	1	-	-	-	-	-	SN SERIES
	CNRBK-136460	PACKING AS. BK306SNMY	-	-	1	-	-	-	-	SN SERIES
	CNRBK-136470	PACKING AS. BK306MSMY	-	-	1	-	-	-	-	MS SERIES
	CNRBK-136500	PACKING AS. BK306SNSG	-	-	-	1	-	-	-	SN SERIES
	CNRBK-137430	PACKING AS. BK306GSSG	-	-	-	1	-	-	-	GS SERIES
	CNRBK-136480	PACKING AS. BK306SNHK	-	-	-	-	1	-	-	SN SERIES
	CNRBK-136490	PACKING AS. BK306MSHK	-	-	-	-	1	-	-	MS SERIES
	CNRBK-136530	PACKING AS. BK306SNWG	-	-	-	-	-	1	-	SN SERIES
	CNRBK-136520	PACKING AS. BK306SNAE	-	-	-	-	-	-	1	SN SERIES
	CNRAK-158610	PAPER PROTECTOR FRONT BK305	-	1	-	-	1	-	-	

7.6 Replacement Part List : NR-BK346 SERIES

Parts List

Safety	Ref. No.	Part No.	Part Name	Model/Q'ty							Remark	
				NR-BK346SN,MS,GS								
				Vietnam VN	RBD WA	Malaysia MY	Sin-DBD SG	Hong Kong HK	PGF WG	GULF AE		
	1	CNRAE-140782	COVER HINGE TOP-N	1	1	1	1	1	1	1	1	SN SERIES
		CNRAE-140792	COVER HINGE TOP-S	1	-	1	-	1	-	-	-	MS SERIES
	2	CNRAE-140801	CAP HINGE TOP	1	1	1	1	1	1	1	1	
S	3	CNRAE-140751	HINGE TOP	1	1	1	1	1	1	1	1	
	4	CNRAF-189550	COIL	1	1	1	1	1	1	1	1	
	5	CNRAG-170410	COVER RADIANT	1	1	1	1	1	1	1	1	
S	6	CNRAG-170400	HEATER AS. DEFROST	1	1	1	1	1	1	1	1	
S	7	CNRBG-181440	TEMP. FUSE AS.	1	1	1	1	1	1	1	1	
	8	CNRAG-168920	SENSOR DEFROST	1	1	1	1	1	1	1	1	
	9	CNRBG-182070	FAN MOTOR AS.	1	1	1	1	1	1	1	1	
	10	CNRAF-188520	COVER COIL BACK	1	1	1	1	1	1	1	1	
	11	CNRAF-188500	COVER COIL	1	1	1	1	1	1	1	1	
	12	CNRAF-188510	SHUTTER	1	1	1	1	1	1	1	1	
	13	CNRAH-295580	TRAY FC	1	1	1	1	1	1	1	1	
	14	CNRBH-145450	ICE CUBE TRAY AS.	1	1	1	1	1	1	1	1	
	15	CNRAH-295620	BOX ICE TRAY	1	1	1	1	1	1	1	1	
S	16	CNRAE-141290	HINGE CENTER	1	1	1	1	1	1	1	1	
	17	CNRAG-153290	DOOR SWITCH	1	1	1	1	1	1	1	1	
		CNRAH-315390	LABEL REF. BK346SNVN	1	-	-	-	-	-	-	-	SN SERIES
		CNRAH-315400	LABEL REF. BK346MSVN	1	-	-	-	-	-	-	-	MS SERIES
		CNRAH-315410	LABEL REF. BK346GSVN	1	-	-	-	-	-	-	-	GS SERIES
		CNRAH-315470	LABEL REF. BK346SNWA	1	1	-	-	-	-	-	-	SN SERIES
		CNRAH-315420	LABEL REF. BK346SNMY	-	-	1	-	-	-	-	-	SN SERIES
		CNRAH-315430	LABEL REF. BK346MSMY	-	-	1	-	-	-	-	-	MS SERIES
		CNRAH-315460	LABEL REF. BK346SNSG	-	-	-	1	-	-	-	-	SN SERIES
		CNRAH-316800	LABEL REF. BK346GSSG	-	-	-	1	-	-	-	-	GS SERIES
		CNRAH-315440	LABEL REF. BK346SNHK	-	-	-	-	1	-	-	-	SN SERIES
		CNRAH-315450	LABEL REF. BK346MSHK	-	-	-	-	1	-	-	-	MS SERIES
		CNRAH-315490	LABEL REF. BK346SNWG	-	-	-	-	-	1	-	-	SN SERIES
		CNRAH-315480	LABEL REF. BK346SNAE	-	-	-	-	-	-	1	-	SN SERIES
S	19	CNRAE-141200	HINGE BOTTOM	1	1	1	1	1	1	1	1	
	20	CNRAC-236050	LEG SHELL	1	1	1	1	1	1	1	1	
	21	CNRAC-221910	ADJUSTER BOLT	1	1	1	1	1	1	1	1	
	22	CNRAH-295570	INS. AIR GUIDE	1	1	1	1	1	1	1	1	
	23	CNRAG-245521	AG FILTER BIO	1	1	1	1	1	1	1	1	
	24	CNRAH-295560	CASE AIR GUIDE	1	1	1	1	1	1	1	1	
	25	CNRBG-184500	PAS-BK305 (LED)	1	1	1	1	1	1	1	1	
	26	CNRBG-182050	PAS-BJ175 (CONTROL)	1	1	1	1	1	1	1	1	
	27	CNRAH-295550	COVER LED	1	1	1	1	1	1	1	1	
	28	CNRAH-288340	DIAL CONTROL	1	1	1	1	1	1	1	1	
	29	CNRAH-295630	CHILLED CASE	1	1	1	1	1	1	1	1	
	30	CNRBH-145460	GLASS TRAY PC AS.	2	2	2	2	2	2	2	2	
	31	CNRAH-312851	TRAY PCF BK6	1	1	1	1	1	1	1	1	
	32	CNRAH-312861	TRAY PCB BK6	1	1	1	1	1	1	1	1	
	33	CNRAH-295690	TRAY CRISPER	1	1	1	1	1	1	1	1	
	34	CNRAH-297190	SASH TRAY CRISPER	1	1	1	1	1	1	1	1	
	35	CNRAH-295700	CRISPER	1	1	1	1	1	1	1	1	
S		CNRAH-315500	LABEL NAME & WIRING D. BK346SNVN	1	-	-	-	-	-	-	-	SN SERIES
S		CNRAH-315510	LABEL NAME & WIRING D. BK346MSVN	1	-	-	-	-	-	-	-	MS SERIES
S		CNRAH-315520	LABEL NAME & WIRING D. BK346GSVN	1	-	-	-	-	-	-	-	GS SERIES
S		CNRAH-315580	LABEL NAME & WIRING D. BK346SNWA	-	1	-	-	-	-	-	-	SN SERIES
S		CNRAH-315530	LABEL NAME & WIRING D. BK346SNMY	-	-	1	-	-	-	-	-	SN SERIES
S		CNRAH-315540	LABEL NAME & WIRING D. BK346MSMY	-	-	1	-	-	-	-	-	MS SERIES
S		CNRAH-315570	LABEL NAME & WIRING D. BK346SNSG	-	-	-	1	-	-	-	-	SN SERIES
S		CNRAH-316890	LABEL NAME & WIRING D. BK346GSSG	-	-	-	1	-	-	-	-	GS SERIES
S		CNRAH-315550	LABEL NAME & WIRING D. BK346SNHK	-	-	-	-	1	-	-	-	SN SERIES
S		CNRAH-315560	LABEL NAME & WIRING D. BK346MSHK	-	-	-	-	1	-	-	-	MS SERIES
S		CNRAH-315600	LABEL NAME & WIRING D. BK346SNWG	-	-	-	-	-	1	-	-	SN SERIES
S		CNRAH-315590	LABEL NAME & WIRING D. BK346SNAE	-	-	-	-	-	-	1	-	SN SERIES
	37	CNRAF-189660	PAN WATER EVA.	1	1	1	1	1	1	1	1	
	38	CNRAG-169330	COVER BOX CAPACITOR	1	1	1	1	1	1	1	1	
	39	CNRBG-186320	PAS-BK305S (MAIN)	1	1	1	1	1	1	1	1	
	40	CNRAG-153360	MF. CAPACITOR	1	1	1	1	1	1	1	1	
	41	CNRAG-169320	BOX CAPACITOR	1	1	1	1	1	1	1	1	
S		CNRBG-187050	SUPPLY CORD & HARNESS WIRE MAIN	1	1	-	-	-	-	-	-	C2P
S		CNRBG-184560		-	-	1	1	1	-	-	1	S3P
S		CNRBG-184580		-	-	-	-	-	-	1	-	C2P(SHUKO)
	43	CNRAJ-162500	U-RING WASHER	4	4	4	4	4	4	4	4	
	44	CNR91-105480	COMPRESSOR	1	1	1	1	1	1	1	1	
S	45	CNR06-598100	MOTOR PROTECTOR	1	1	1	1	1	1	1	1	
S	46	CNR06-592700	PTC. RELAY	1	1	1	1	1	1	1	1	
	47	CNRGD-036540	COVER PROTECTOR	1	1	1	1	1	1	1	1	
	48	CNR39-340920	5 GRAM DRYER W	1	1	1	1	1	1	1	1	
	49	CNR39-163082	CLAMPER DRYER	1	1	1	1	1	1	1	1	
	50	CNR01-219932	RUBBER GROMMET	4	4	4	4	4	4	4	4	

Parts List

Safety	Ref. No.	Part No.	Part Name	Model/Q' ty							Remark
				NR-BK346SN,MS,GS							
				Vietnam	RBD	Malaysia	Sin-DBD	Hong Kong	PGF	GULF	
VN	WA	MY	SG	HK	WG	AE					
	51	CNRBG-179830	EARTH AS. COMP. 180	1	1	1	1	1	1	1	
	52	CNRBF-159520	CROSSRAIL REAR AS.	1	1	1	1	1	1	1	
	53	CNRAD-358960	GASKET DOOR FC	1	1	1	1	1	1	1	
	54	CNRBD-372010	DOOR AS. FC (FOAM) N	1	1	1	1	1	1	1	SN SERIES
		CNRBD-393510	DOOR AS. FC (FOAM) MS BK6	1	-	1	-	1	-	-	MS SERIES
		CNRBD-393520	DOOR AS. FC (FOAM) GS BK6	1	-	-	1	-	-	-	GS SERIES
	55	CNRAD-339801	EMBLEM (Panasonic logo)	1	1	1	1	1	1	1	
	56	CNRAD-156574	LATCH DOOR	2	2	2	2	2	2	2	
	57	CNRAD-354010	STOPPER DOOR	2	2	2	2	2	2	2	
	58	CNRAD-359310	GASKET DOOR PC	1	1	1	1	1	1	1	
	59	CNRBD-372140	DOOR AS. PC (FOAM) SN	1	1	1	1	1	1	1	SN SERIES
		CNRBD-373690	DOOR AS. PC (FOAM) MS BK346	1	-	1	-	1	-	-	MS SERIES
		CNRBD-373700	DOOR AS. PC (FOAM) GS BK346	1	-	-	1	-	-	-	GS SERIES
	60	CNRAD-361440	SHELF FC	2	2	2	2	2	2	2	
	61	CNRAD-323180	TRAY EGG 8	1	1	1	1	1	1	1	
	62	CNRAD-359100	SHELF EGG	2	2	2	2	2	2	2	
	63	CNRAD-359110	SHELF BOTTLE	1	1	1	1	1	1	1	
	64	CNRAD-359120	SHELF BOTTLE S	1	1	1	1	1	1	1	
	65	CNRBG-187060	BOX CAPACITOR AS.	1	1	-	-	-	-	-	C2P
		CNRBG-184530		-	-	1	1	1	-	1	S3P
		CNRBG-184540		-	-	-	-	-	1	-	C2P(SHUKO)
	66	CNRBH-147650	SLIDE GLASS TRAY PC AS. BK6	1	1	1	1	1	1	1	

Packing List

Ref. No.	Part No.	Part Name	Model/Q' ty							Remark
			NR-BK346SN,MS,GS							
			Vietnam	RBD	Malaysia	Sin-DBD	Hong Kong	PGF	GULF	
VN	WA	MY	SG	HK	WG	AE				
	CNRAK-158640	CARTON TOP	1	1	1	1	1	1	1	
	CNRBK-128470	TOP PAD AS.	1	1	1	1	1	1	1	
	CNRBK-128480	TOP PAD F/B AS.	-	1	-	-	1	-	-	
	CNRBK-128150	BOTTOM TRAY AS.	1	1	1	1	1	1	1	
	CNRAJ-151650	PLASTIC COVER	1	1	1	1	1	1	1	
	CNRAK-158660	INS PAD COMP.	1	1	1	1	1	1	1	
	CNRAK-170510	INSTRUCTION BOOK VN (VN)	1	-	-	-	-	-	-	
	CNRAK-170550	INSTRUCTION BOOK (RBD/ARB/PER)	-	1	-	-	-	1	1	
	CNRAK-170520	INSTRUCTION BOOK (MAL/ENG/CHI)	-	-	1	-	-	-	-	
	CNRAK-170540	INSTRUCTION BOOK-SG (ENG/CHI)	-	-	-	1	-	-	-	
	CNRAK-170530	INSTRUCTION BOOK-HK (CHI/ENG)	-	-	-	-	1	-	-	
	CNRBK-136790	PACKING AS. BK346SNVN	1	-	-	-	-	-	-	SN SERIES
	CNRBK-136800	PACKING AS. BK346MSVN	1	-	-	-	-	-	-	MS SERIES
	CNRBK-136810	PACKING AS. BK346GSVN	1	-	-	-	-	-	-	GS SERIES
	CNRBK-136870	PACKING AS. BK346SNWA	-	1	-	-	-	-	-	SN SERIES
	CNRBK-136820	PACKING AS. BK346SNMY	-	-	1	-	-	-	-	SN SERIES
	CNRBK-136830	PACKING AS. BK346MSMY	-	-	1	-	-	-	-	MS SERIES
	CNRBK-136860	PACKING AS. BK346SNSG	-	-	-	1	-	-	-	SN SERIES
	CNRBK-137440	PACKING AS. BK346GSSG	-	-	-	1	-	-	-	GS SERIES
	CNRBK-136840	PACKING AS. BK346SNHK	-	-	-	-	1	-	-	SN SERIES
	CNRBK-136850	PACKING AS. BK346MSHK	-	-	-	-	1	-	-	MS SERIES
	CNRBK-136890	PACKING AS. BK346SNWG	-	-	-	-	-	1	-	SN SERIES
	CNRBK-136880	PACKING AS. BK346SNAE	-	-	-	-	-	-	1	SN SERIES
	CNRAK-158780	PAPER PROTECTOR FRONT BK345	-	1	-	-	1	-	-	