

Service Manual

Body Hair/Beard Trimmer

Model No. **ER2403**
ER2405

Middle East



⚠ WARNING

This service information is designed for experienced repair technicians only and is not designed for use by the general public. It does not contain warnings or cautions to advise non-technical individuals of potential dangers in attempting to service a product. Products powered by electricity should be serviced or repaired only by experienced professional technicians. Any attempt to service or repair the product or products dealt with in this service information by anyone else could result in serious injury or death.

IMPORTANT SAFETY NOTICE

There are special components used in this equipment which are important for safety. These parts are marked by ⚠ in the Schematic Diagrams, Circuit Board Diagrams, Exploded Views and Replacement Parts List. It is essential that these critical parts should be replaced with manufacturer's specified parts to prevent shock, fire or other hazards. Do not modify the original design without permission of manufacturer.

TABLE OF CONTENTS

	PAGE	PAGE
1 Warning-----	2	
2 Specifications-----	2	
3 Troubleshooting Guide-----	3	
4 Disassembly and Assembly Instructions-----	4	
5 Wiring Connection Diagram-----	9	
6 Schematic Diagram-----	10	
7 Exploded View and Replacement Parts List-----	11	

Panasonic

© 2007 Matsushita Electric Industrial Co., Ltd. All rights reserved. Unauthorized copying and distribution is a violation of law.

1 Warning

Caution:

- Pb free solder has a higher melting point than standard solder; Typically the melting point is 50 - 70°F (30 - 40°C) higher. Please use a soldering iron with temperature control and adjust it to 750 ± 20°F (400 ± 10°C). In case of using high temperature soldering iron, please be careful not to heat too long.
- Pb free solder will tend to splash when heated too high (about 1100°F / 600°C).

2 Specifications

2.1. ER2403

Power source	DC 3.0V (Two AAA (LR03) dry-cell batteries)
Weight	128g (including comb attachment and batteries)

Supplied accessories	Comb attachment
	Cleaning brush
	Oil

2.2. ER2405

Power source	AC 100-240V, 50-60Hz
Power consumption	Approx. 2.0W
Motor voltage	1.2V DC
Rated time	Approx. 50 minutes
Charging time	8 Hours
Weight	126g

Supplied accessories	Comb attachment
	Cleaning brush
	Oil

3 Troubleshooting Guide

3.1. ER2403

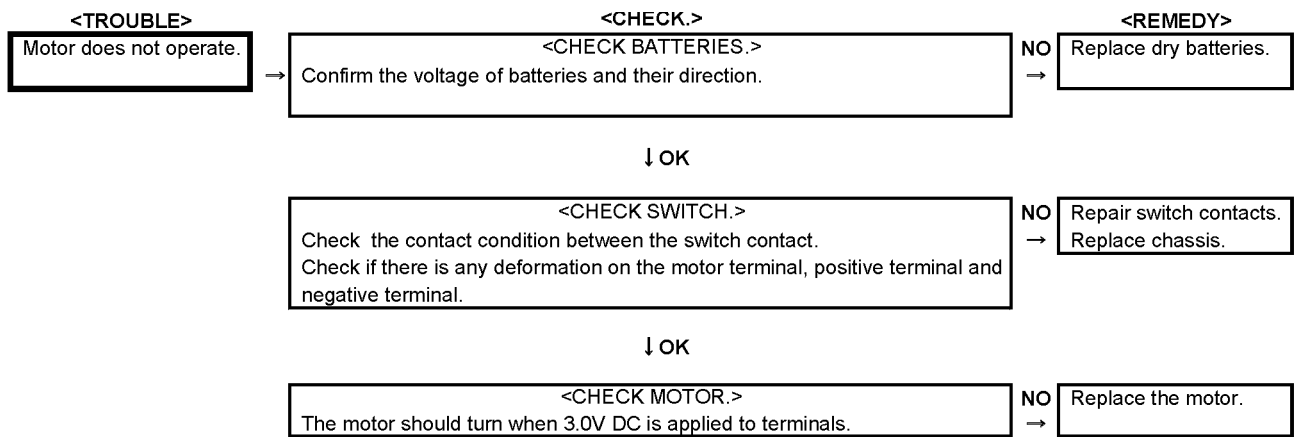

3.2. ER2405

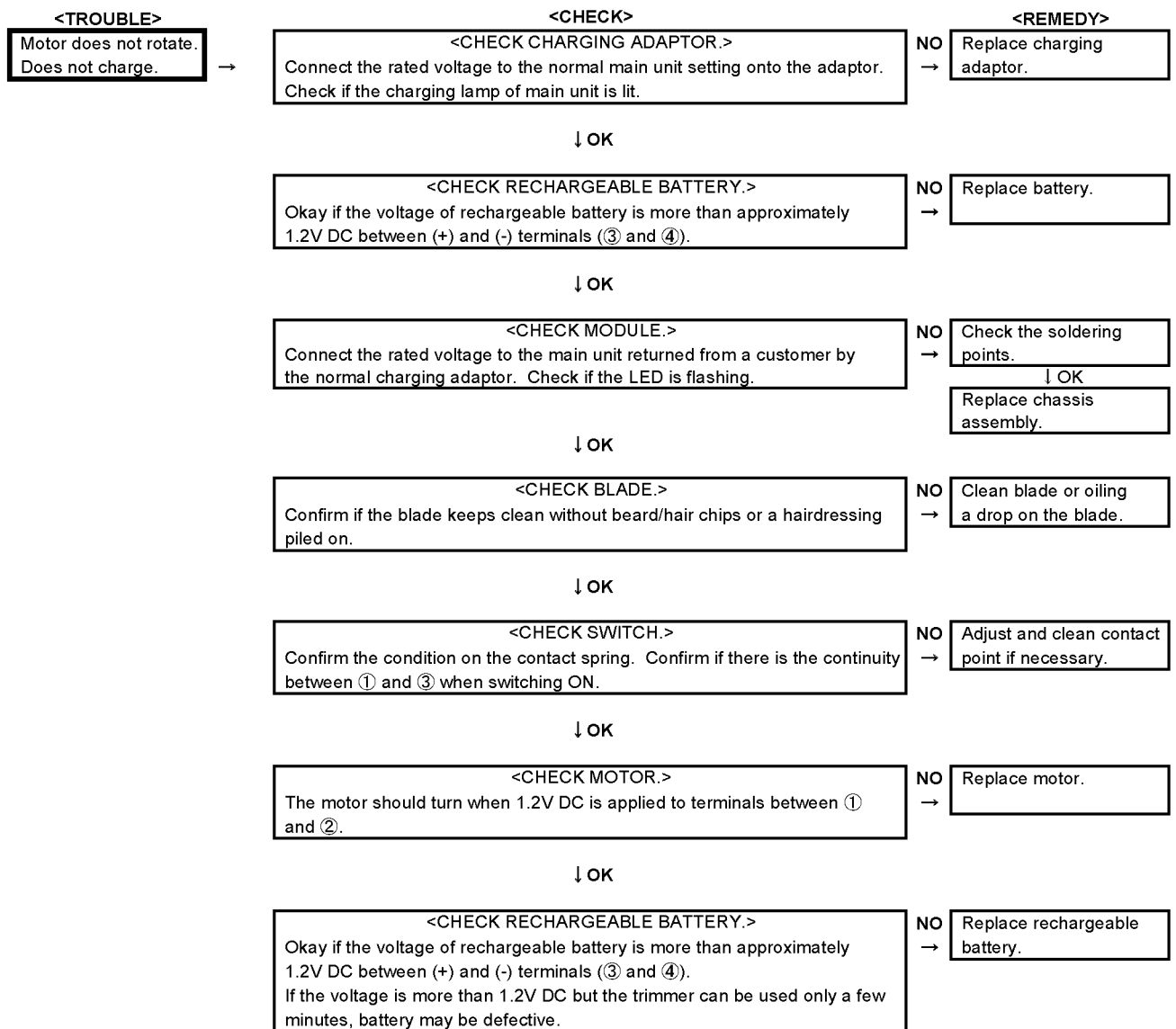

4 Disassembly and Assembly Instructions

4.1. Disassembly Instructions for ER2403

1. Remove the attachment and the blade.
2. Loosen two housing screws.

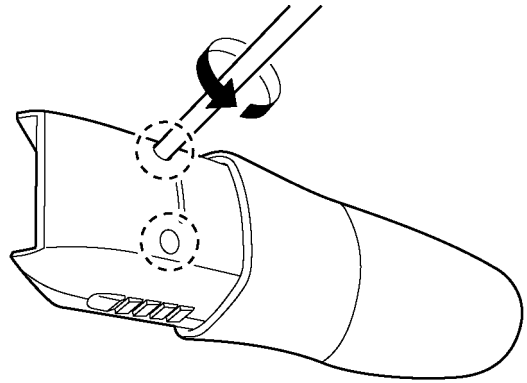

3. Remove the housing C.

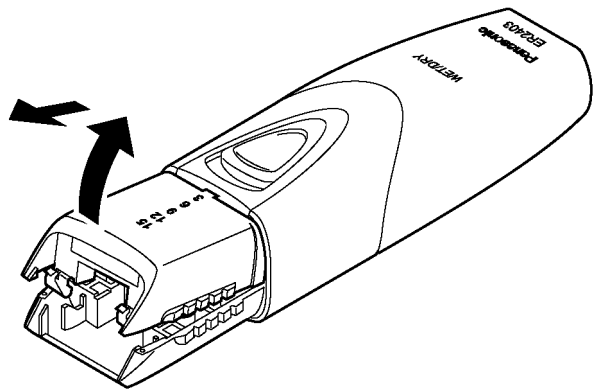

4. Insert the flat-head screwdriver into the hole of switch handle and raise it up.

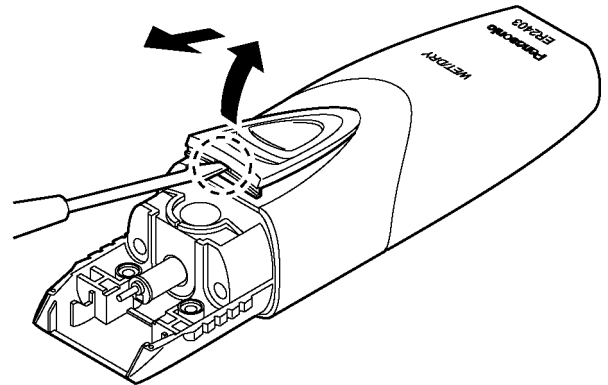

5. Take out the switch cam and the O-ring.

NOTE:

Make sure not to lose them.

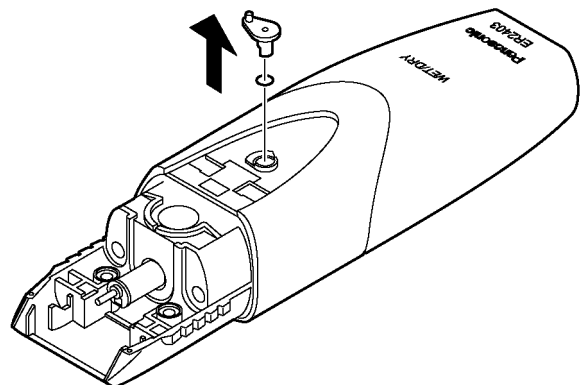

6. Remove the battery cover.

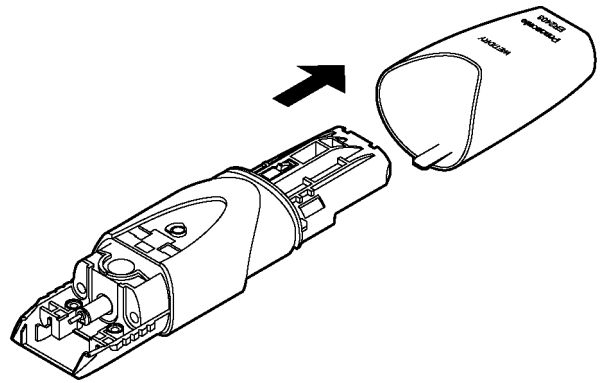

7. Loosen two screws on top.

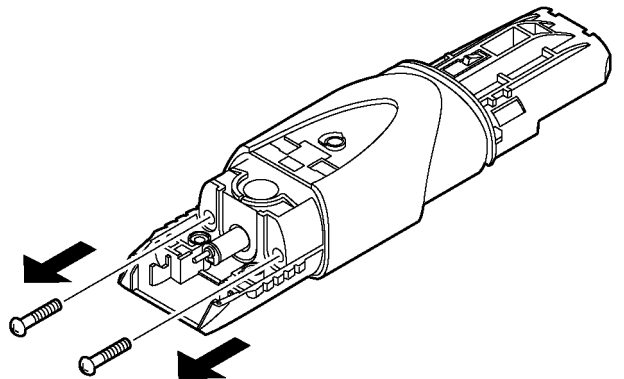

8. Take out the housing B.

NOTE:

Make sure not to lose the O-ring.

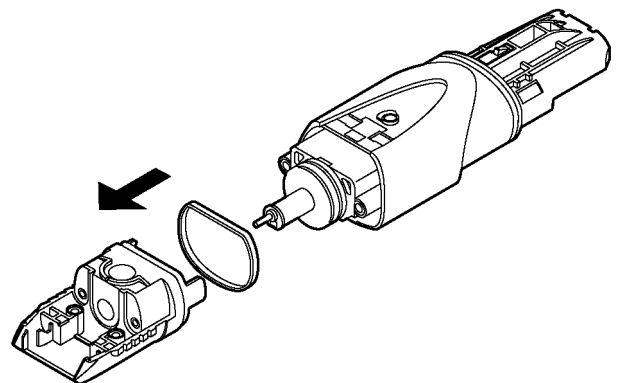

9. Remove the housing A.

NOTE:

Make sure not to lose two screw O-rings.

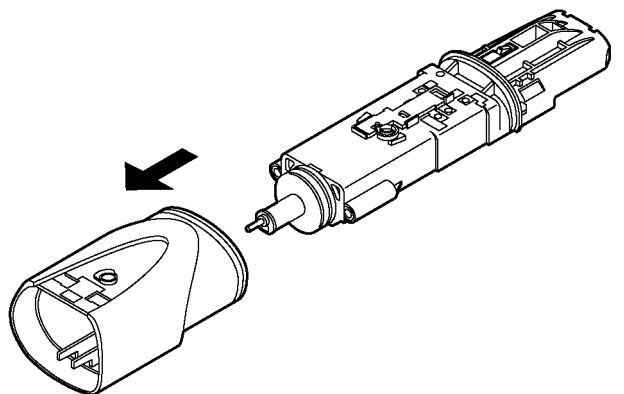

4.2. Disassembly Instructions for ER2405

1. Remove the attachment and the blade.
2. Loosen two housing screws.

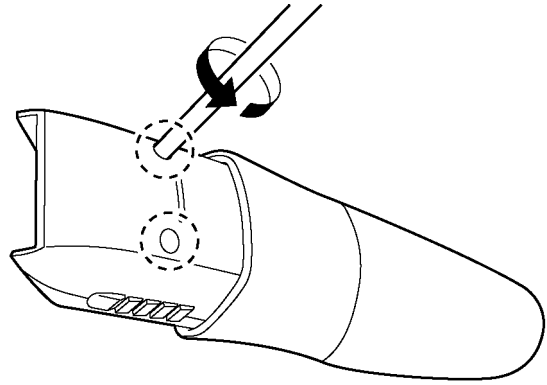

3. Remove the housing C.

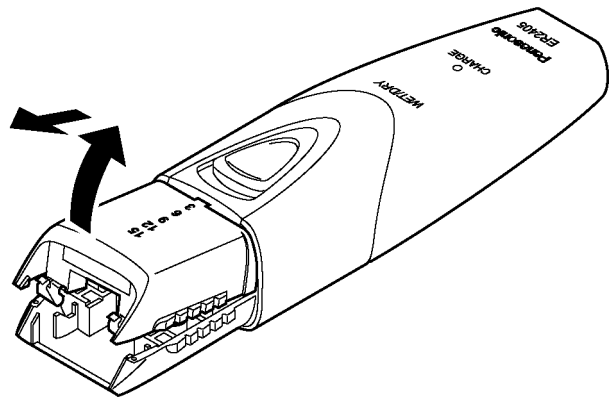

4. Insert the flat-head screwdriver into the hole of switch handle and raise it up.

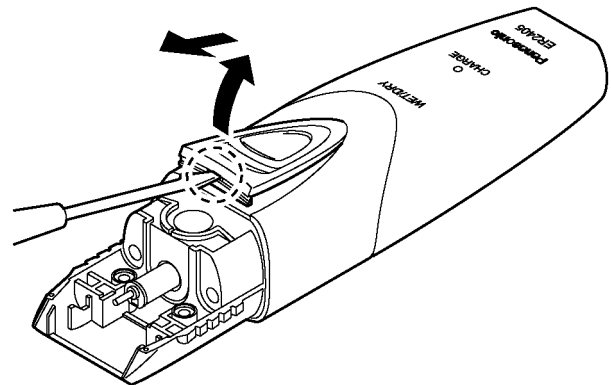

5. Take out the switch cam and the O-ring.

NOTE:

Make sure not to lose them.

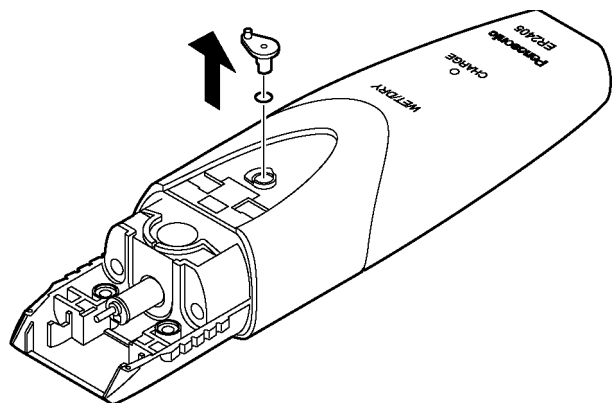

6. Loosen two screws on top.

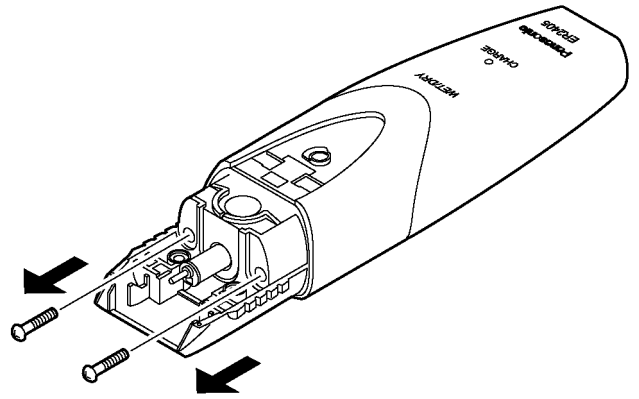

7. Take out the housing B.

NOTE:

Make sure not to lose the O-ring.

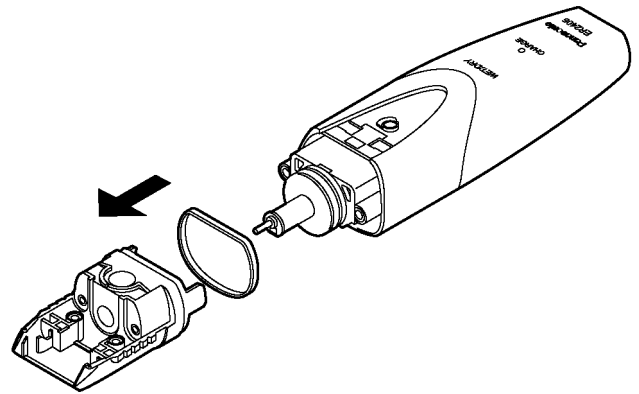

8. Remove the housing A.

NOTE:

Make sure not to lose two screw O-rings.

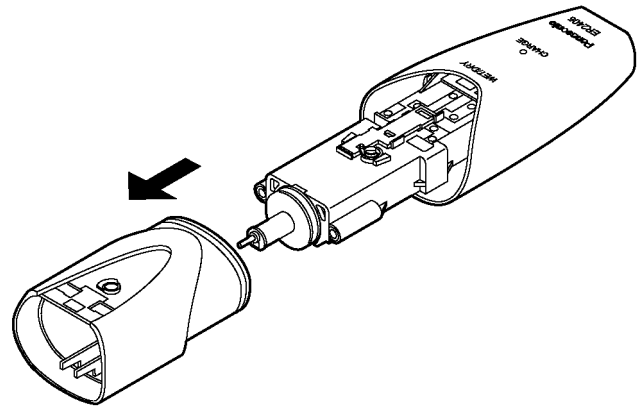

9. Loosen two screws.

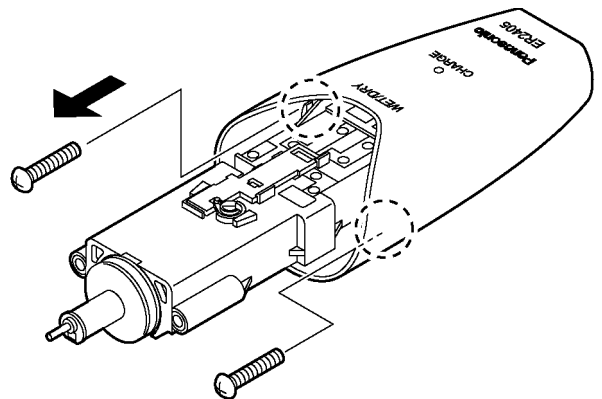

10. Take out the chassis assembly.

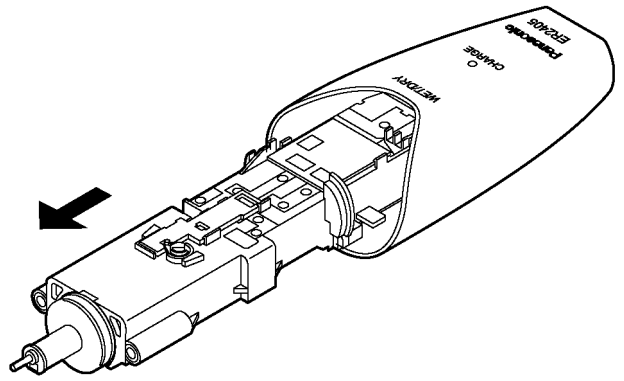

11. Take out the O-ring from the bottom of battery cover.

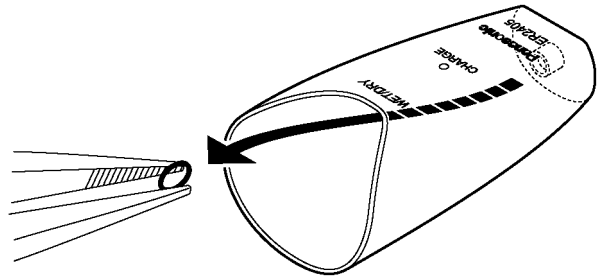

12. Unhook the terminal base to remove from the chassis.

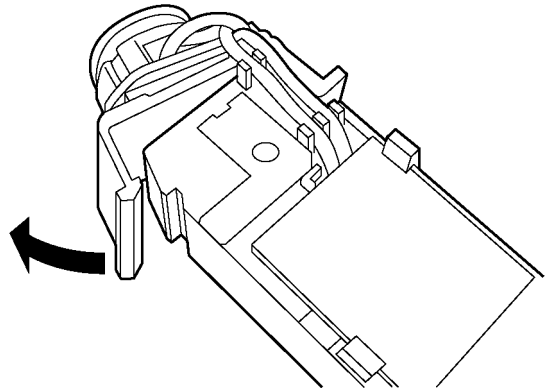

5 Wiring Connection Diagram

5.1. ER2405

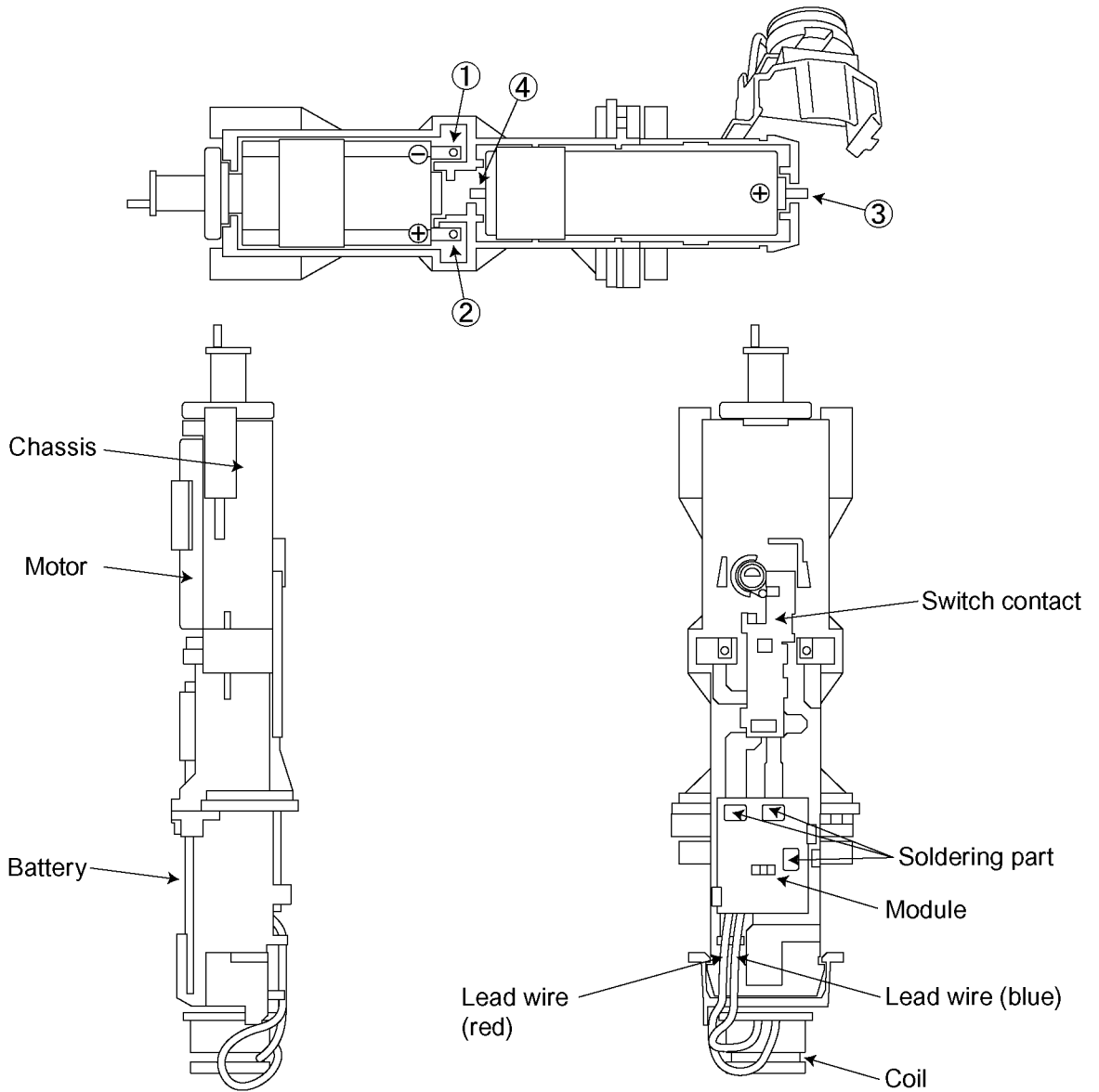

6 Schematic Diagram

6.1. ER2403

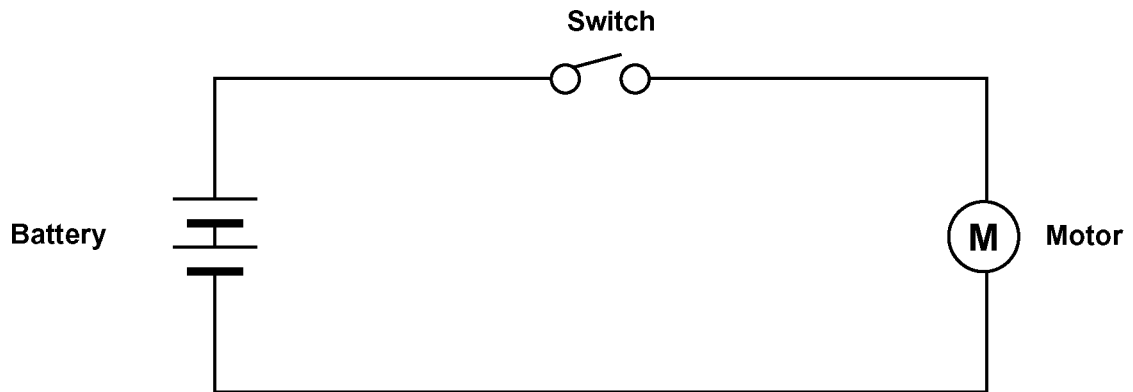

6.2. ER2405

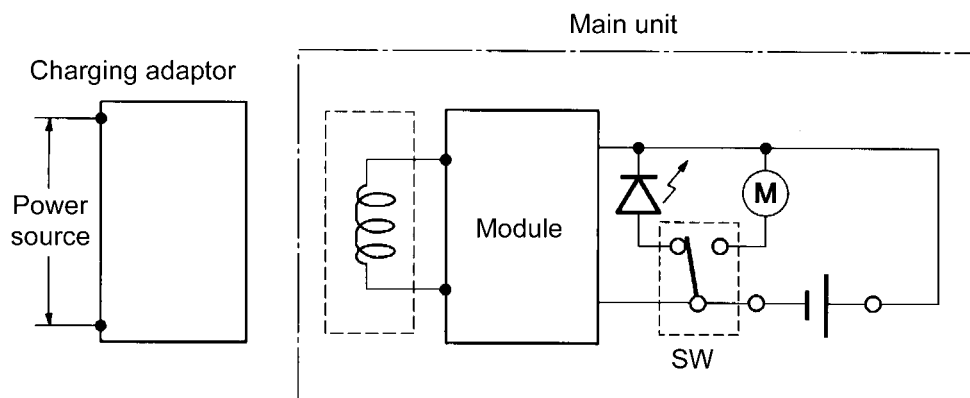

7 Exploded View and Replacement Parts List

Model No. : ER2403 Exploded View for ER2403

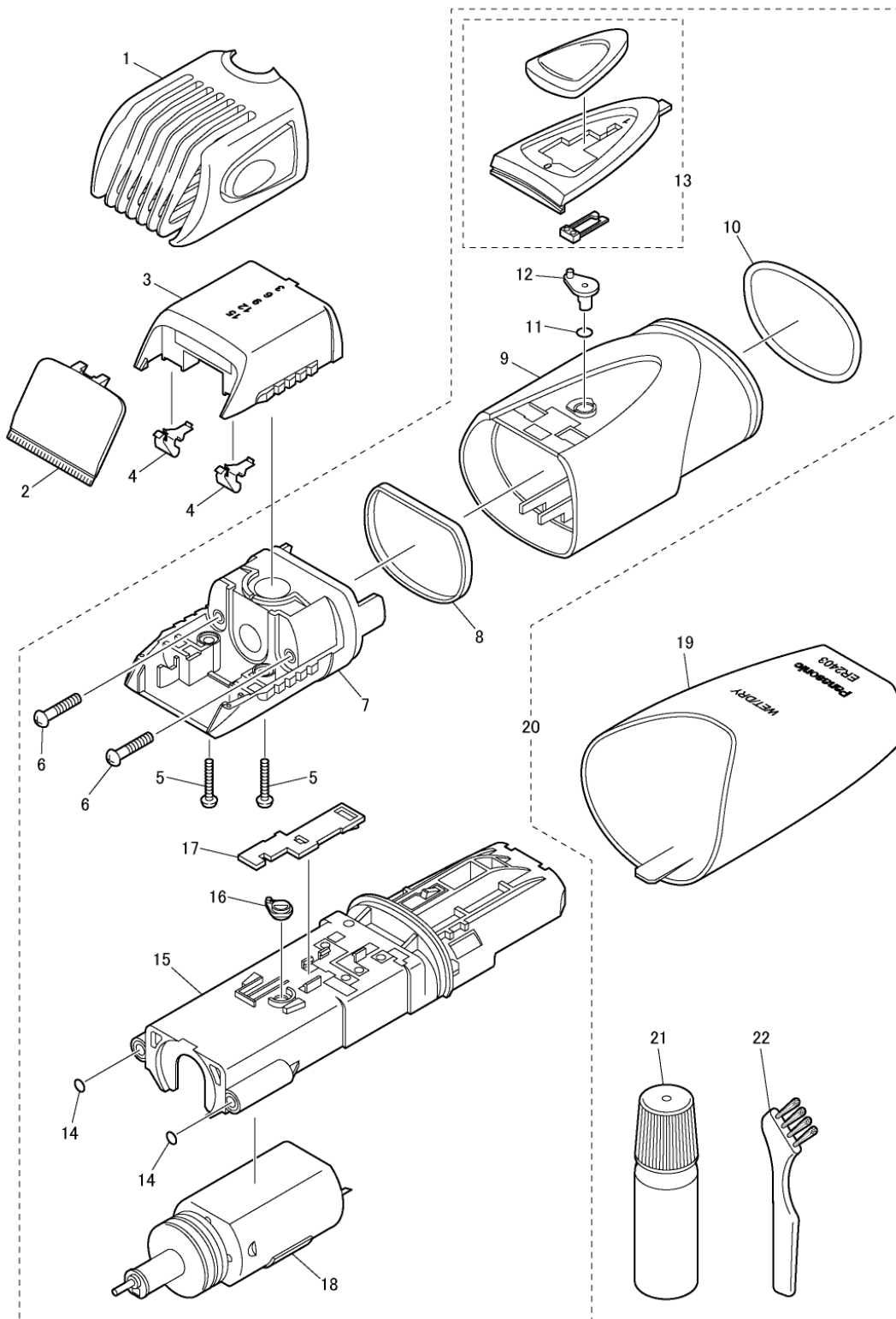

Model No. : ER2403 Parts List

Safety	Ref. No.	Part No.	Part Name & Description	Q'ty	Remarks
ER2403					
	1	WER2405K7397	COMB ATTACHMENT	1	
	2	WER9606E	BLADE BLOCK	1	
	3	WER2405K3077	HOUSING C	1	
	4	WER504L0167	SPRING FOR CUTTER	1ST	
	5	WER2405K6057	TAPPING SCREW	2	(K2-8)
	6	WES7025L9707	SCREW	2	(K2-15)
	7	WER2403K3067	HOUSING B	1	
	8	WER2405L0977	HOUSING B O-RING	1	
	9	WER2403K3057	HOUSING A	1	
	10	WER2405L0987	HOUSING O-RING	1	
	11	WER221L0986	SWITCH O-RING	1	
	12	WER2403L1667	SWITCH CAM	1	
	13	WER2403K3208	SWITCH HANDLE	1	
	14	WER217L0967	SWITCH O-RING	2	(6PCS/PK)
	15	WER2403L0777	CHASSIS	1	
	16	WER2405L1677	CAM	1	
	17	WER2405L3577	SWITCH CONTACT	1	
	18	WER2403L1007	MOTOR	1	
	19	WER2403K3128	BATTERY COVER	1	
	20	WER2403K3038	BODY BLOCK	1	
	21	WER203X7918	OIL	1	
	22	WES76806766	CLEANING BRUSH	1	
	-	WER2403K8008	INDIVIDUAL BOX	1	
	-	WER2403K8108	OPERATING INSTRUCTIONS	1	