

Service Manual

Professional Hair Clipper

Model No. **ER-GC33**

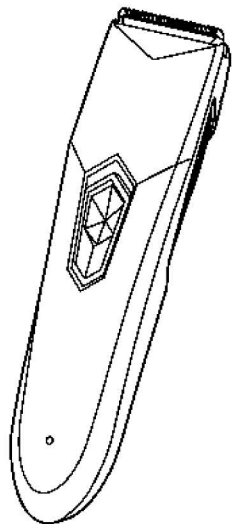

Africa
Middle East

WARNING

This service information is designed for experienced repair technicians only and is not designed for use by the general public. It does not contain warnings or cautions to advise non-technical individuals of potential dangers in attempting to service a product. Products powered by electricity should be serviced or repaired only by experienced professional technicians. Any attempt to service or repair the product or products dealt with in this service information by anyone else could result in serious injury or death.

IMPORTANT SAFETY NOTICE

There are special components used in this equipment which are important for safety. These parts are marked by  in the Schematic Diagrams, Circuit Board Diagrams, Exploded Views and Replacement Parts List. It is essential that these critical parts should be replaced with manufacturer's specified parts to prevent shock, fire or other hazards. Do not modify the original design without permission of manufacturer.

TABLE OF CONTENTS

	PAGE	PAGE
1 Warning -----	2	
2 Specifications -----	2	
3 Troubleshooting Guide -----	3	
4 Disassembly and Assembly Instructions -----	4	
4.1. Disassembly Instructions -----	4	
4.2. Assembly Instructions -----	5	
5 Wiring Connection Diagram -----	6	
6 Schematic Diagram -----	6	
7 Exploded View and Replacement Parts List -----	7	

1 Warning

Caution:

- Pb free solder has a higher melting point than standard solder; Typically the melting point is 50 - 70°F (30 - 40°) higher. Please use a soldering iron with temperature control and adjust it to 750 ± 20°F (400 ± 10°). In case of using high temperature soldering iron, please be careful not to heat too long.
- Pb free solder will tend to splash when heated too high (about 1100°F / 600°C).

2 Specifications

Power source	AC 100-240V, 50-60Hz
Motor voltage	1.2V DC
Charging time	8 hours
Rated usable time with full-charging	40 minutes
Weight	Approx. 180g (Main body)
	Approx. 170g (Adaptor)
Supplied accessories	1-2mm comb attachment
	3-4mm comb attachment
	5-6mm comb attachment
	Comb attachment for underarm (Only for ER-GC33)
	Cleaning brush
	Oil

3 Troubleshooting Guide

(Refer to Wiring Connection Diagram)

<TROUBLE>	<CHECK.>	<REMEDY>
Does not operate.	<p>(Connect adaptor and charge for 10 seconds. Confirm if the switch turn ON.)</p> <p><CHECK ADAPTOR.> Supply the rated voltage to the adaptor. OK if it is more than DC 1.8V between the terminals of the plug.</p>	NO → Replace adaptor.
	<p>↓ OK</p> <p><CHECK SWITCH.> Remove the battery and install the switch to the housing. OK if there is continuity between (1) and (2) with the switch handle ON.</p>	NO → Connecting plate and module.
	<p>↓ OK</p> <p><CHECK MOTOR.> The motor should turn when 1.2V DC is applied to terminals.</p>	NO → Replace motor.
	<p>↓ OK</p> <p><CHECK RECHARGEABLE BATTERY.> Okay if the voltage of rechargeable battery is more than approximately 1.2V DC between (+) and (-) terminals.</p>	NO → Replace rechargeable battery.
	<p>↓ OK</p> <p><CHECK MODULE.> Remove the battery and turn on the switch. OK if there is more than DC1.2V between (1) and (2) terminals on PCB with electricity supplied from the adaptor. NOTE: Make sure of the electrical polarity on adaptor. Remove the battery and turn on the switch.</p>	NO → Replace module.
Does not charge. Does not light the charge indicator lamp.	<p><CHECK RECHARGEABLE BATTERY.> OK if the voltage of rechargeable battery is more than approximately 1.2V DC between (+) and (-) terminals.</p>	NO → Replace rechargeable battery.
	<p>↓ OK</p> <p><CHECK CHARGING CURRENT.> Replace the battery and wire the module & battery assembly referring with the figure 2. Check charging current, if it is more than 75mA when connecting AC power source with swith OFF.</p>	OK → Replace module.

4 Disassembly and Assembly Instructions

4.1. Disassembly Instructions

1. Take out blade.
2. Loosen two screws at right and left side of springs and two screws on housing B.
3. To separate housing A and B with care for preventing breakage of hooks.
4. Take out motor from housing A.
5. Remove module assembly.
6. Remove switch handle.

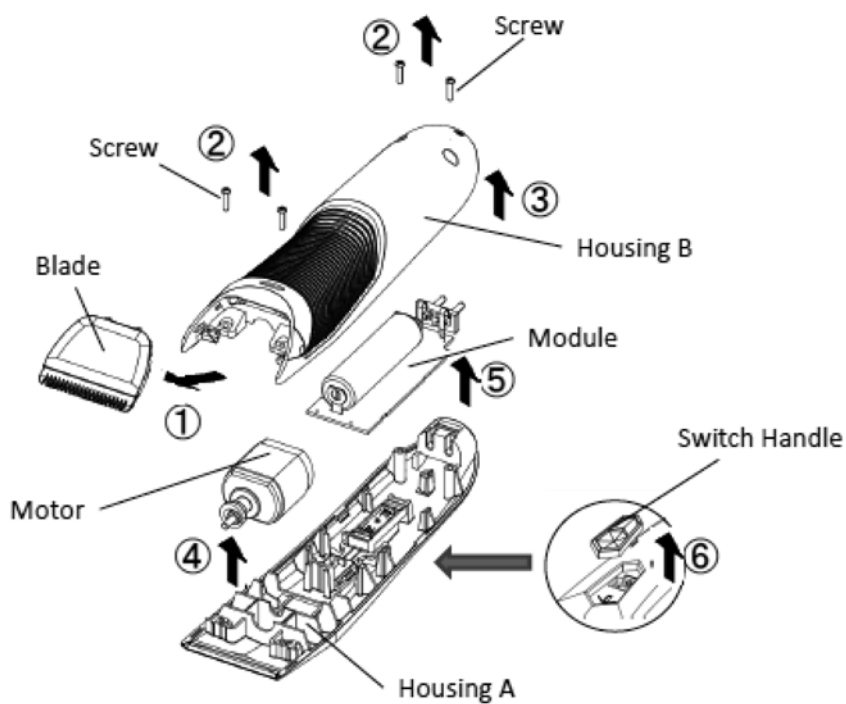

4.2. Assembly Instructions

1. Assemble module block and motor into housing A.

Make sure of a position to be set "o" with both switch handle and switch contact at the rear side of module.

2. Confirm module block or motor to be set into housing A firmly, and then check its operation with connecting adaptor.
3. Assemble housing A and B with care for breakage of housing, and tighten four screws.

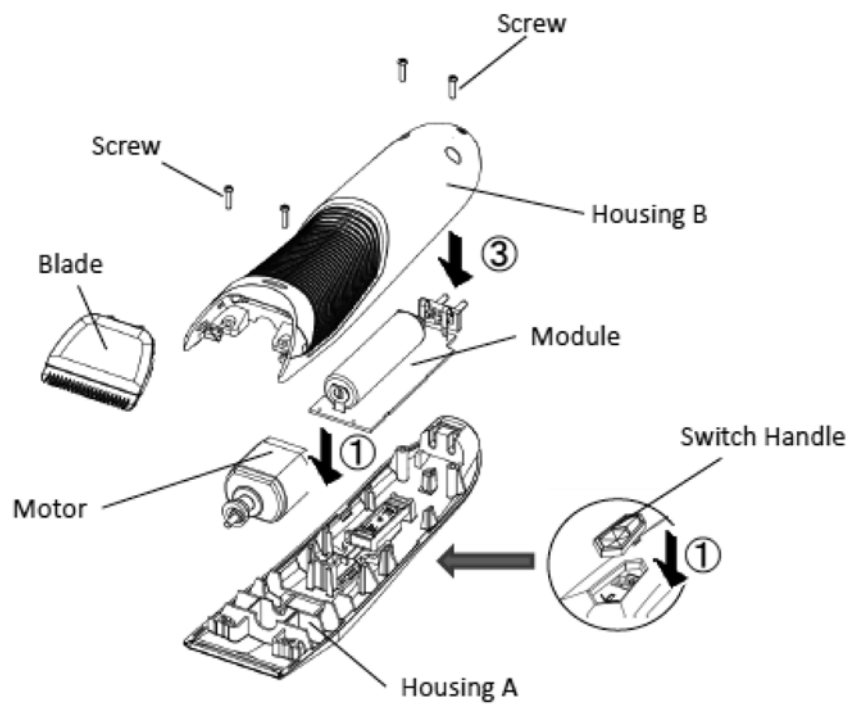

5 Wiring Connection Diagram

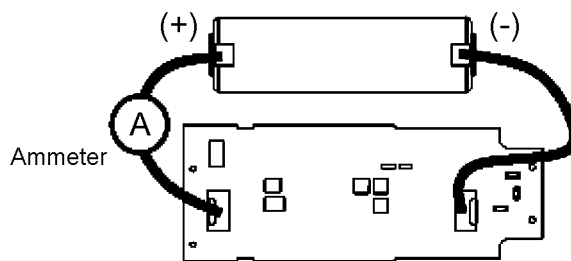
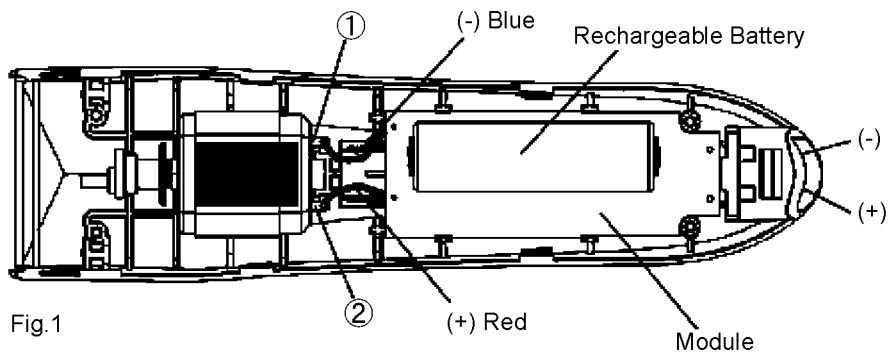

6 Schematic Diagram

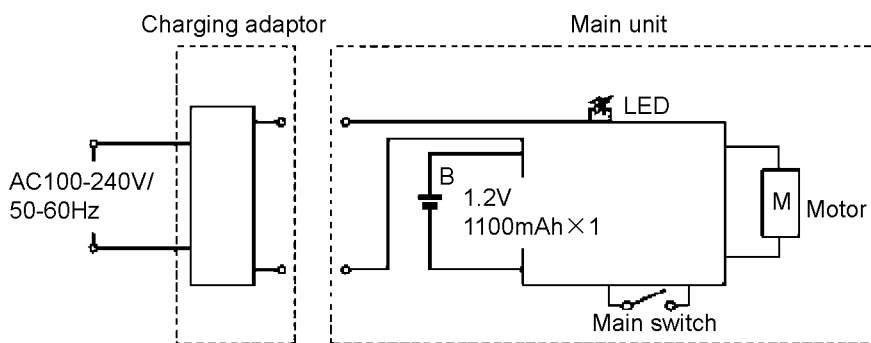

7 Exploded View and Replacement Parts List

7.1. Exploded View for ER-GC33

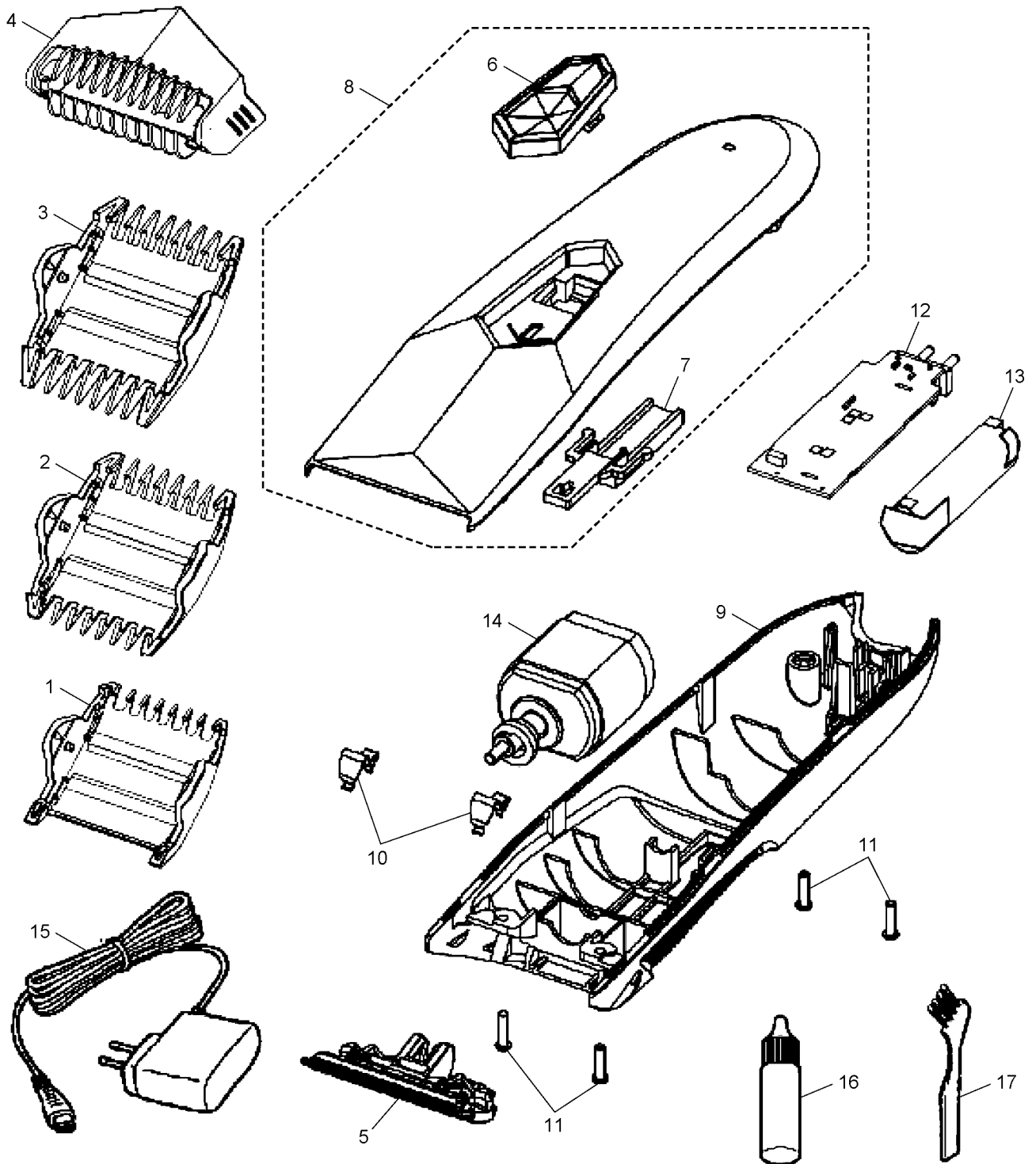

7.2. Replacement Parts List for ER-GC33

Safety	Ref. No.	Part No.	Part Name & Description	Quantity	Remarks
	1	WERC33K7458	COMB ATTACHMENT	1	1-2mm
	2	WERC33K7468	COMB ATTACHMENT	1	3-4mm
	3	WERC33K7478	COMB ATTACHMENT	1	5-6mm
	4	WERC33K7488	EPILATION HEAD FRAME	1	
	5	WER9730E	BLADE BLOCK	1	
	6	WERC33K3108	SWITCH HANDLE	1	
	7	WERC33K3118	CONNECTING PLATE	1	
	8	WERC33K3058	HOUSING A	1	
	9	WERC33K3068	HOUSING B	1	
	10	WER240B0166	BLADE MOUNTING SPRING	2	
	11	WERC33K9008	SCREW	4	K2-8
	12	WERC33L2108	MODULE ASSEMBLY	1	
	13	WERC33L2508	RECHARGEABLE BATTERY	1	Ni-MH TYPE
	14	WERC33L1008	MOTOR	1	
	15	WERC33K7670	ADAPTOR	1	BF-3 PLUG
	15	WERC33K7675	ADAPTOR	1	C2 PLUG
	16	WERC20X7918	OIL	1	
	17	WES76806761	CLEANING BRUSH	1	
	-	WERC33K8008	INDIVIDUAL BOX	1	
	-	WERC33K8009	INDIVIDUAL BOX	1	only for Middle East
	-	WERC33K8108	OPERATING INSTRUCTIONS	1	