

Service Manual

Rechargeable Shaver



Model No. **ES-LV95**

Model No. **ES-LV94**

Model No. **ES-LV65**

Model No. **ES-LV54**

Asia

China

Middle East

⚠ WARNING

This service information is designed for experienced repair technicians only and is not designed for use by the general public. It does not contain warnings or cautions to advise non-technical individuals of potential dangers in attempting to service a product. Products powered by electricity should be serviced or repaired only by experienced professional technicians. Any attempt to service or repair the product or products dealt with in this service information by anyone else could result in serious injury or death.

IMPORTANT SAFETY NOTICE

There are special components used in this equipment which are important for safety. These parts are marked by **⚠** in the Schematic Diagrams, Circuit Board Diagrams, Exploded Views and Replacement Parts List. It is essential that these critical parts should be replaced with manufacturer's specified parts to prevent shock, fire or other hazards. Do not modify the original design without permission of manufacturer.

TABLE OF CONTENTS

	PAGE	PAGE
1 Warning-----	2	
2 Specifications -----	2	
3 Troubleshooting Guide-----	3	
4 Disassembly and Assembly Instructions -----	8	
5 Schematic Diagram-----	13	
6 Exploded View and Replacement Parts List -----	14	

Panasonic

© Panasonic Corporation, 2013.
All rights reserved. Unauthorized copying and distribution is a violation of law.

1 Warning

Caution:

- Pb free solder has a higher melting point than standard solder; Typically the melting point is 50 - 70°F (30 - 40°C) higher. Please use a soldering iron with temperature control and adjust it to 750 ± 20°F (400 ± 10°C). In case of using high temperature soldering iron, please be careful not to heat too long.
- Pb free solder will tend to splash when heated too high (about 1100°F / 600°C).

2 Specifications

Power source	AC 100-240V, 50-60Hz (Automatic voltage conversion)
Power consumption	Approx. 10W (when charging)
Charging time	1 Hour
Shaves per charge	14 times (3 minutes shave)
Weight	200g (without cap)

Supplied accessories	Self-cleaning recharger (ES-LV95 and ES-LV94)
	Soft case
	Oil
	Cleaning brush

3 Troubleshooting Guide

3.1. Main unit and charging adaptor

<TROUBLE>	<CHECK>	<REMEDY>
Motor does not rotate. Does not charge. Functions for a moment and stops.	<p align="center"><CHECK CHARGING ADAPTOR.></p> Supply the rated voltage to the adaptor. And confirm the continuity. OK if it is approx. DC6V between the terminals of the plug at the no-load operation.	NO → Replace charging adaptor.
↓ OK		
	<p align="center"><CHECK RECHARGEABLE BATTERY.></p> Okay if the voltage of rechargeable battery is more than approximately 3.6V DC between (+) and (-) terminal.	NO → Replace rechargeable battery.
↓ OK		
	<p align="center"><CHECK MODULE.></p> Wire the main unit returned from a customer refer with the following figure, and connect the rated voltage to it by the normal adaptor. When switching ON and OFF, check if the indicator  of LCD is lid for ES-LV95 and ES-LV94 or RED LED is lid for ES-LV65 and ES-LV54. Discharge the battery completely and check charging current, if it is more than 600-800mA when connecting the charging adaptor..	NO → Check the soldering points. ↓ OK Replace module.
↓ OK		
	<p align="center"><CHECK LINEAR MOTOR.></p> Wire the main unit returned from a customer refer with the following figure, and connect the rated voltage to it by the normal adaptor. When switching ON and OFF, check if motor rotates. (Once the battery is replaced, the battery needs to charge for a while, otherwise linear motor may not operate.)	NO → Replace linear motor assembly.

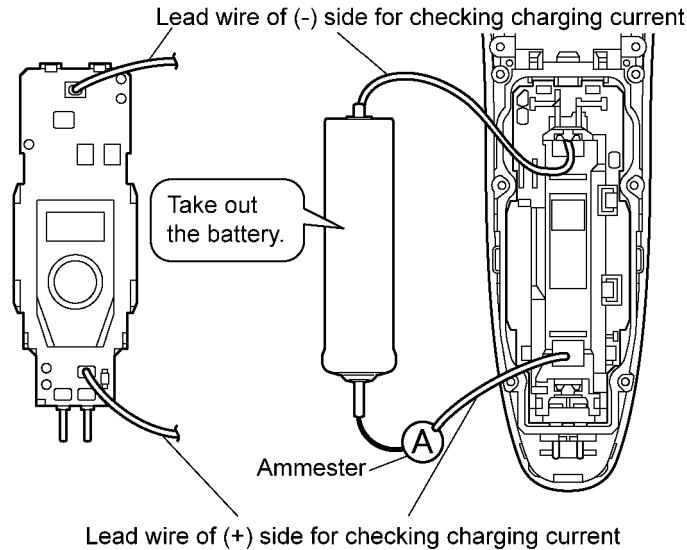

NOTE:

Once taking the battery out, the shaver is RESET. The shaver must be charged for several seconds first.

NOTE:

Completely discharge and then fully charge before returning the shaver to the customer.

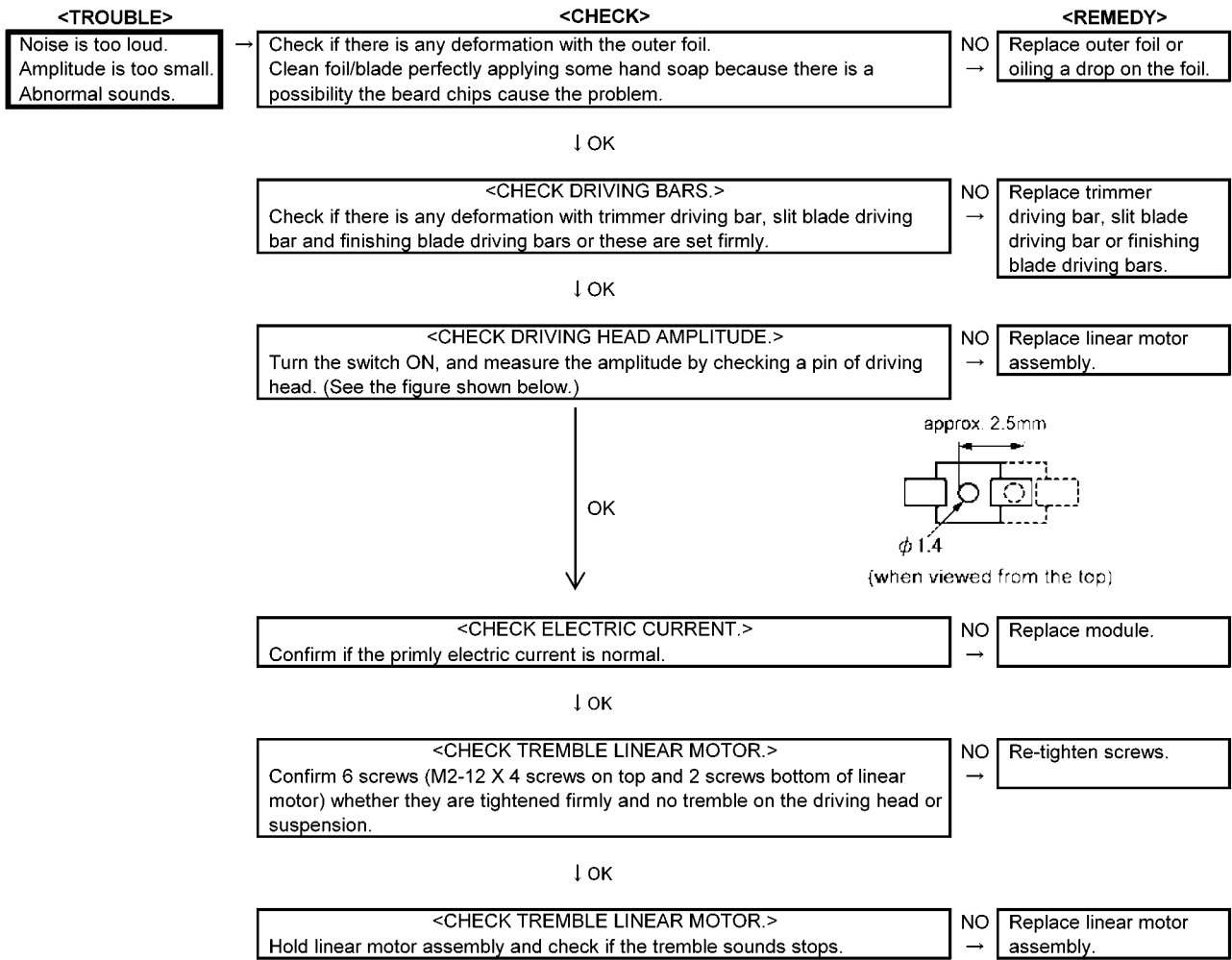

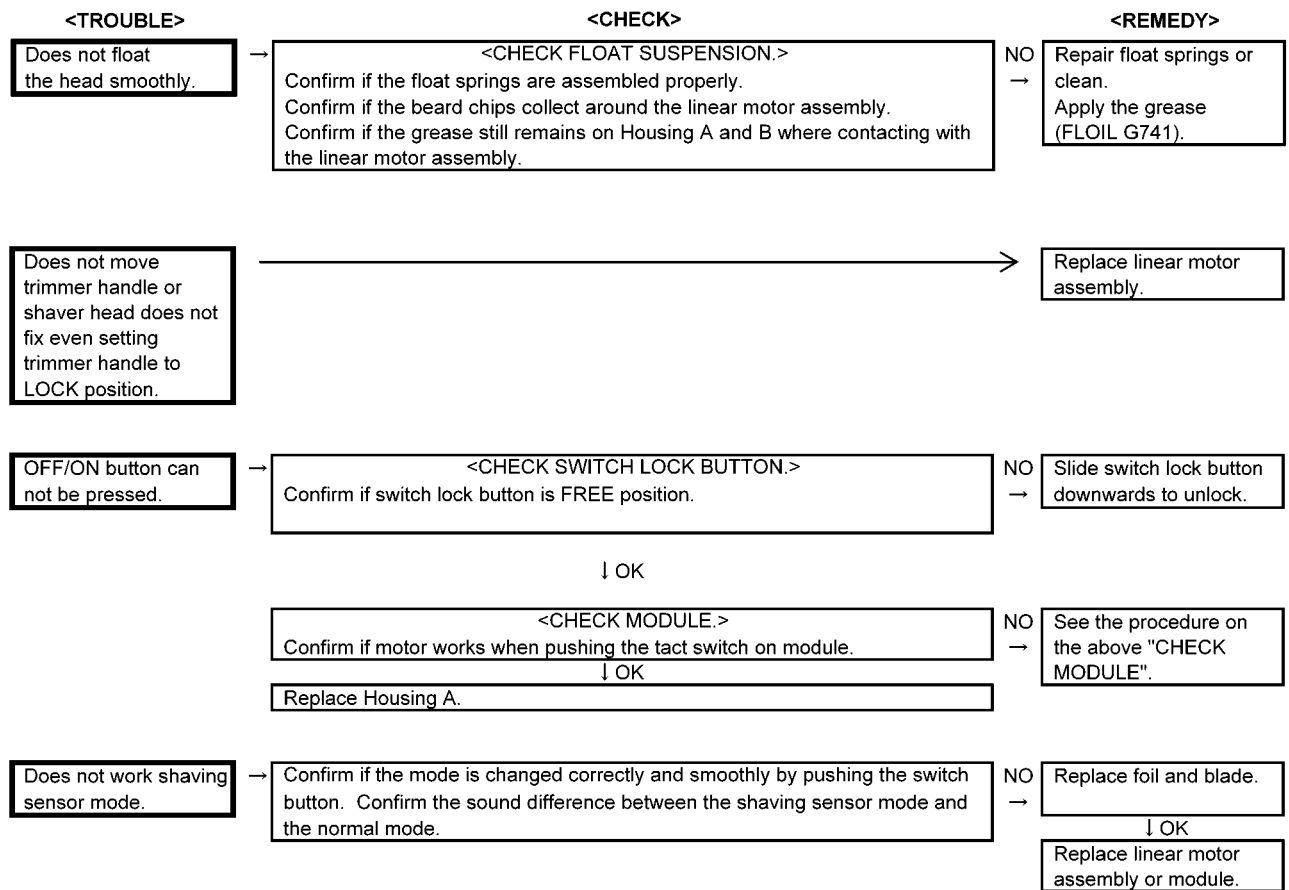

4 Disassembly and Assembly Instructions

4.1. Disassembly instructions

Follow the procedure below to disassemble the main unit.

1. Remove the cap, the outer foil with outer foil frame and the inner blades.

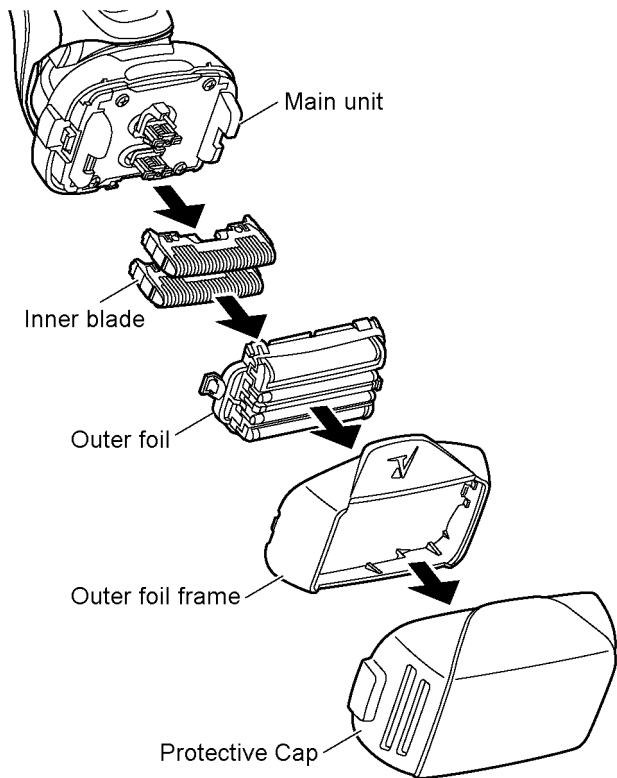

2. How to disassemble the housing A and B.

- a) Loosen a screw.
- b) Remove the bottom cover.
- c) Remove the rear panel.
- d) Loosen 6 screws.
- e) Remove the housing B.

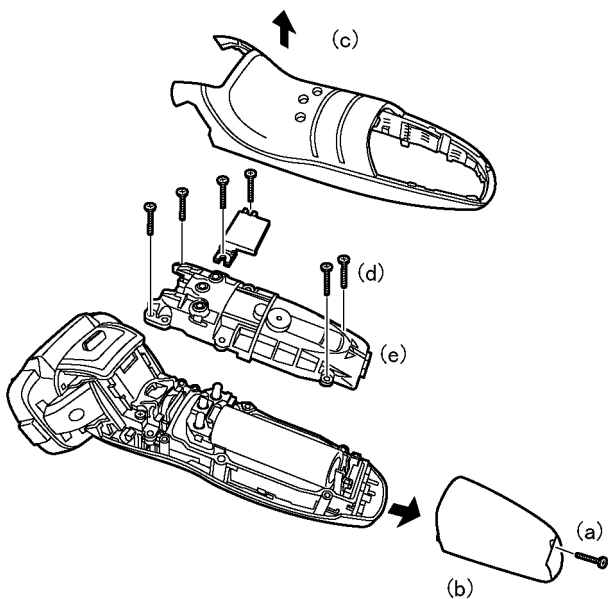

3. To remove the trimmer driving bar, finishing blade driving bar or the slit blade driving bar, press bars outward.

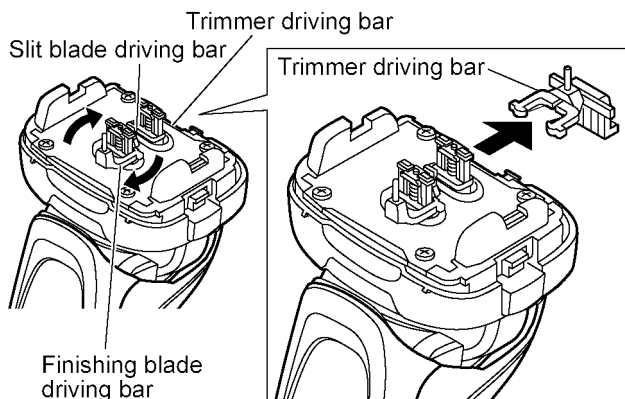

4. Pull up the battery and chassis block from the linear motor side first. Then, slide it upward and take it out from the housing A.

NOTE:

Do not pull the battery and chassis block forcefully due to connecting the linear motor by the lead wires.

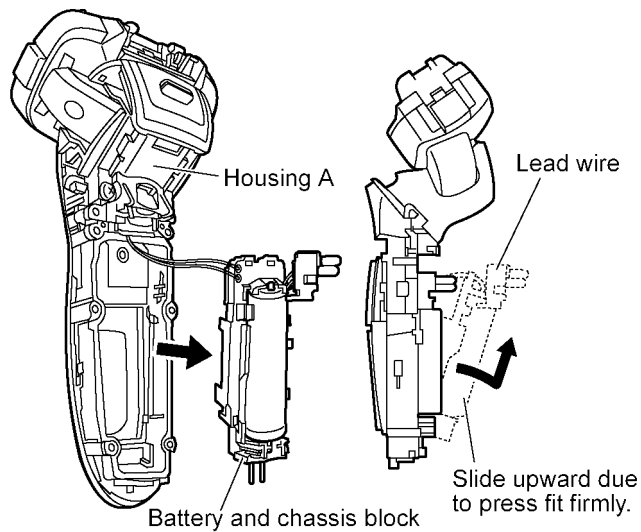

5. Take out the battery from the chassis.

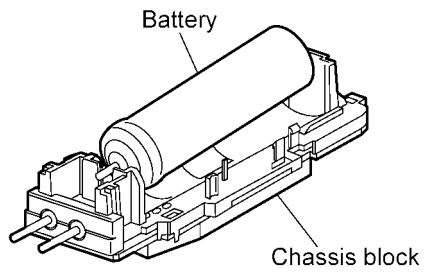

6. Unsolder the lead wires from the module.

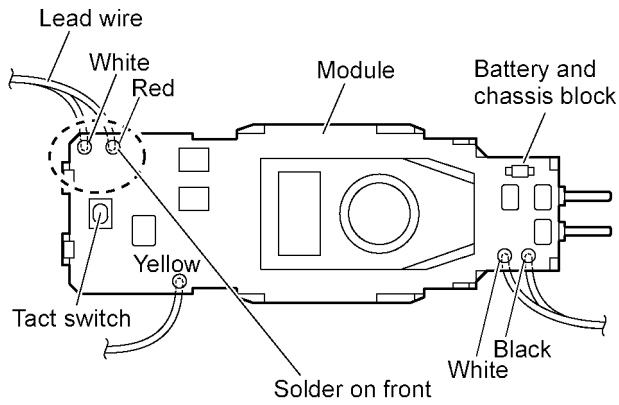

7. Loosen two screws.

8. Move gently the linear motor assembly down and unhook it and remove the float springs from housing A.

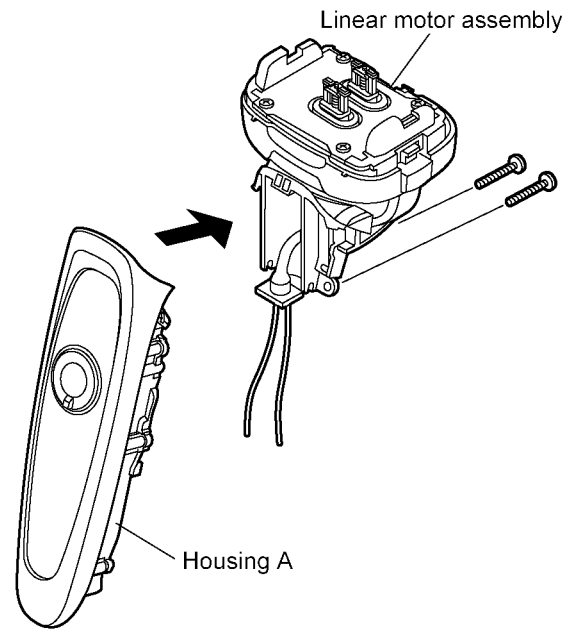

4.2. Caution in assembly

NOTE:

When reassembling, replace the new waterproof seal. Make sure whether there is NO foreign substance sticking around a part covered with waterproof seal.

1. Solder the lead wires with the module.

NOTE:

Make sure of the color of lead wires.

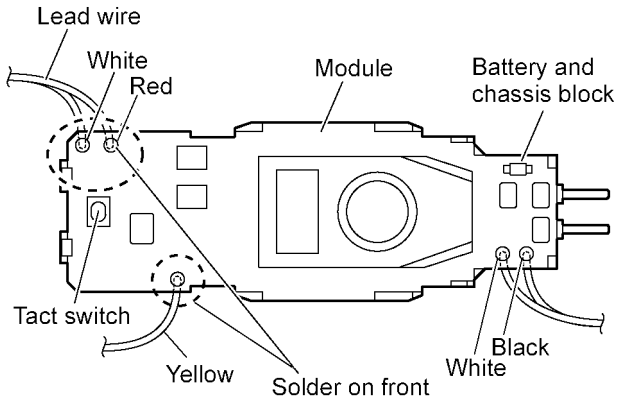

2. Attach the tube holder. Tighten two screws between the linear motor assembly and the housing A.
3. When inserting the module and chassis block into the housing A, confirm if the module does not get any damage or deformation.

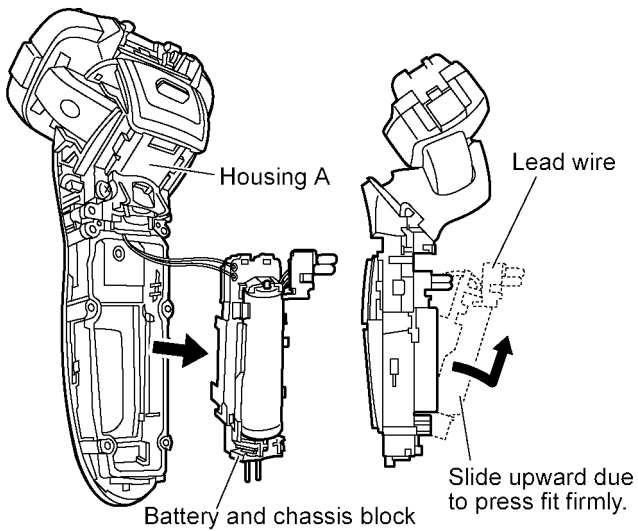

4. Make sure that the lead wires set in position to avoid abnormal noise. Install (+) terminal of battery into the terminal plate at the bottom cover side and firmly set the battery sliding the direction of arrow. Attach (-) terminal of battery.

NOTE:

Once taking the battery out, the shaver is RESET. The shaver must be charged for about 10 seconds first.

NOTE:

Completely discharge and then fully charge before returning the shaver to the customer.

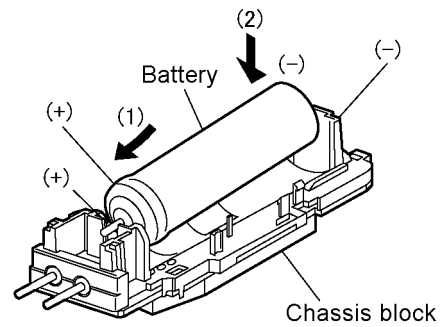

The projection A should be set into the place A'.

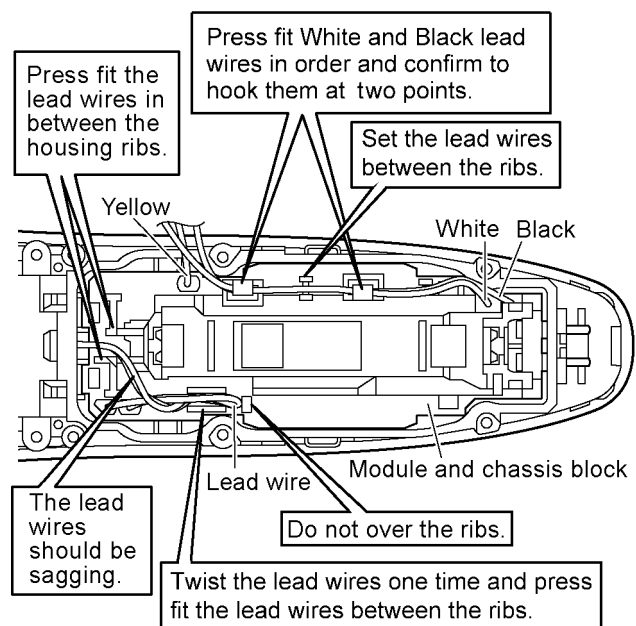
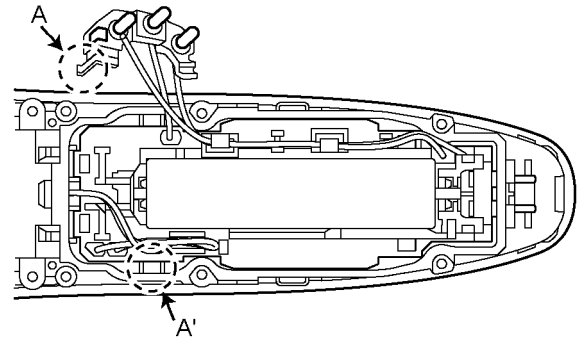

6. Tighten six screws and attach the rear panel firmly.

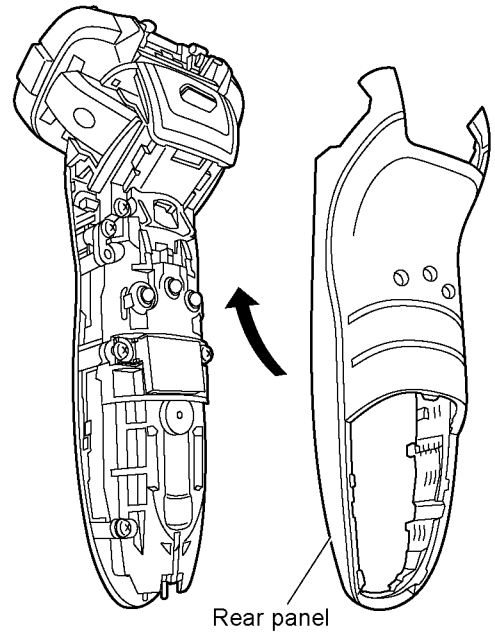
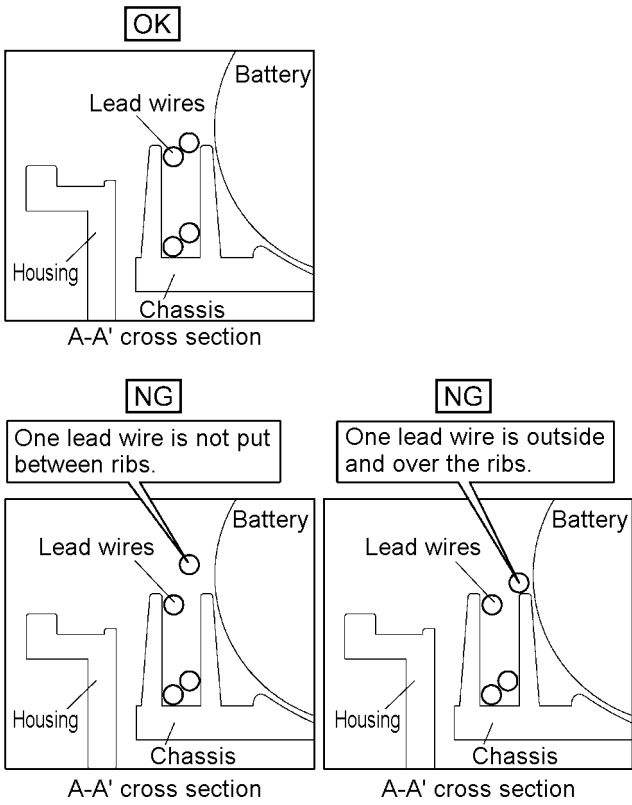

5. When putting the housing A and the housing B together, make sure if the waterproof seal must be fitted properly and no foreign substance sticking around.

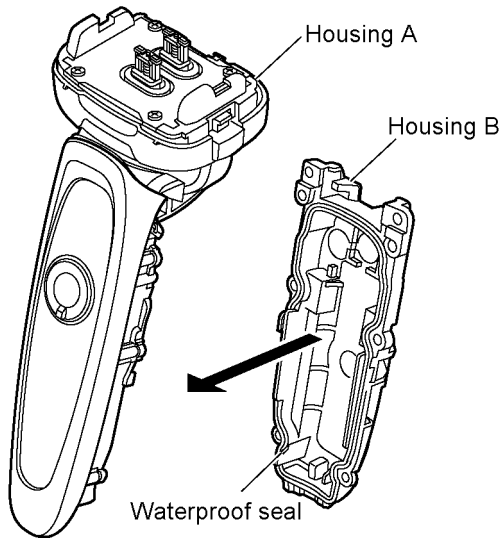

7. Attach the bottom cover and tighten a screw.

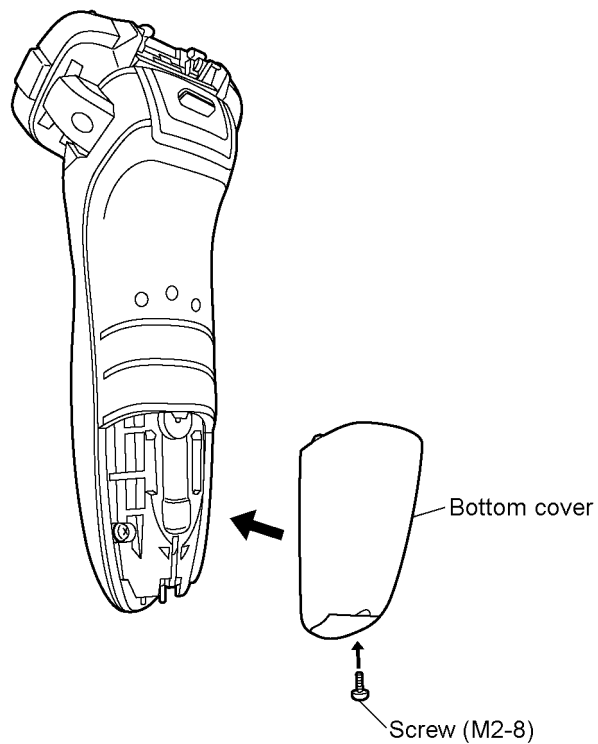

8. Set the trimmer driving bar, the finishing blade driving bar and the slit blade driving bar.

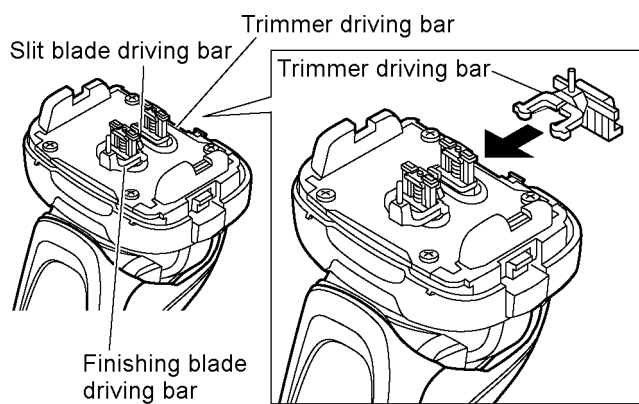

6.5. Exploded View for ES-LV65

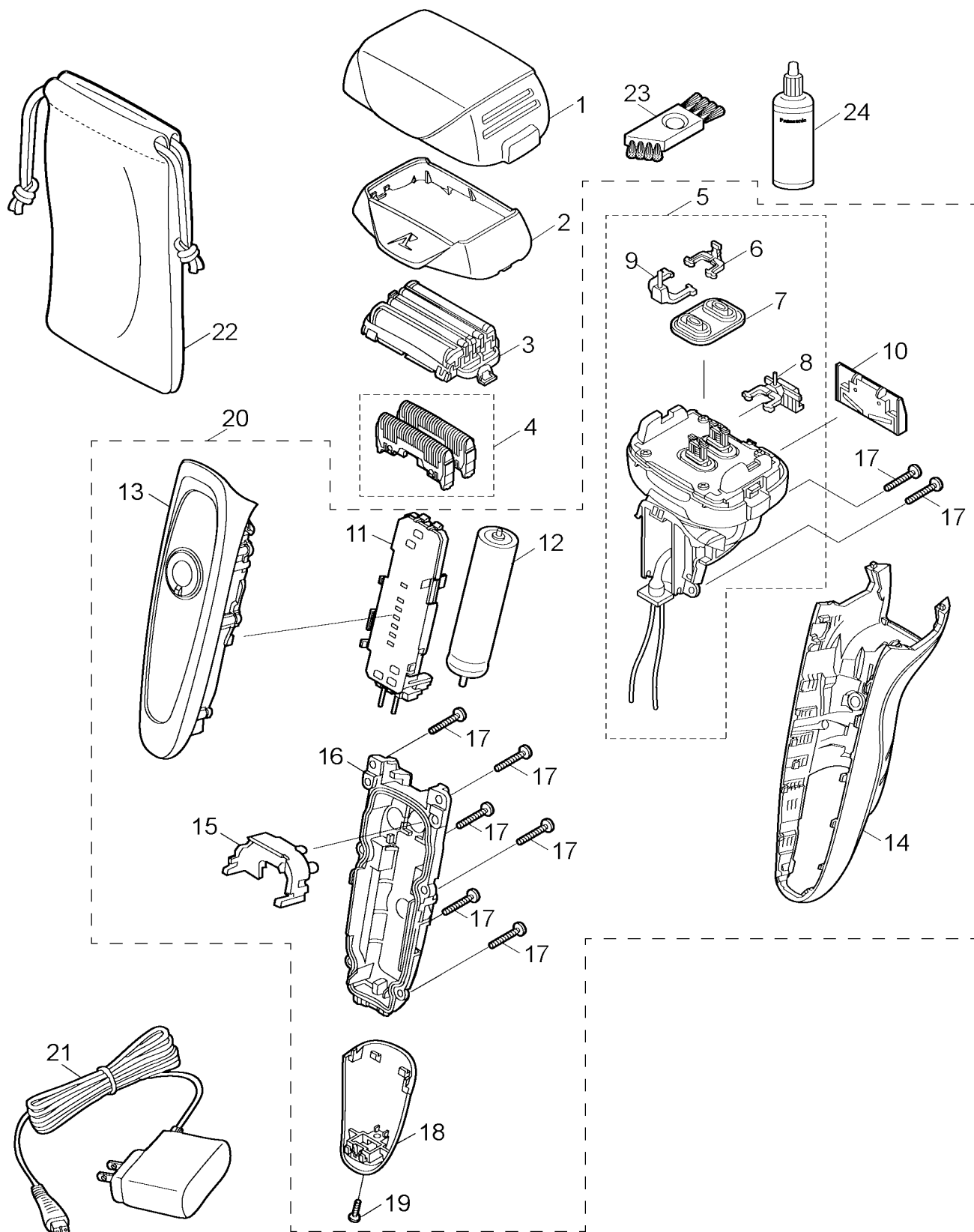

6.6. Replacement Parts List for ES-LV65

Safety	Ref. No.	Part No.	Part Name & Description	Quantity	Remarks
	1	WESLV94X7158	PROTECTIVE CAP	1	
	2	WESELV8S0047	FOIL FRAME	1	
	3	WES9173E	SYSTEM OUTER FOIL	1	
	4	WES9170E	INNER BLADE	1ST	
	5	WESLV99L1007	LINEAR MOTOR ASSEMBLY	1	
	6	WESLV90L1077	SLIT BLADE DRIVING BAR	1	
	7	WESLV90L0327	WATERPROOF RUBBER	1	
	8	WESLV90L1087	TRIMMER DRIVING BAR	1	
	9	WESLV90L1177	FINISHING BLADE DRIVING BAR	1	
	10	WESLV99L1507	TRIMMER	1	
	11	WESLV65L2128	MODULE	1	
	12	WESLV95L2509	RECHARGEABLE BATTERY	1	LM-ION TYPE
	13	WESLV65S3058	HOUSING A	1	
	14	WESELV9K3367	REAR PANEL	1	
	15	WESLA54L0497	REAR COVER	1	
	16	WESLV90H3068	HOUSING B	1	
	17	WES8176L6007	P TIGHT SCREW	8	M2-12
	18	WESLV65K3121	BOTTOM COVER	1	
	19	WES8176L6057	TAPPING SCREW	1	M2-8
	20	WESLV65S3032	BODY BLOCK	1	
	21	WESLV90K7P63	AC ADAPTOR	1	C-2 PLUG
	22	WESLA92K3747	SOFT CASE	1	
	23	WES8093H7057	CLEANING BRUSH	1	
	24	WES8196X7918	OIL	1	
	-	WESLV65S8004	INDIVIDUAL BOX	1	
	-	WESLV65S8005	INDIVIDUAL BOX	1	only for Middle East
	-	WESLV65S8102	OPERATING INSTRUCTIONS	1	