

Service Manual

Nail Care

Model No. **ES-WC30**

Asia
Middle East

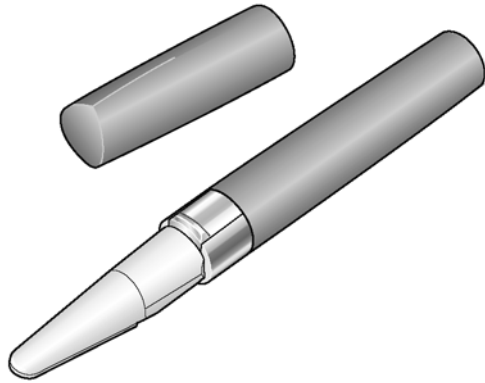

⚠ WARNING

This service information is designed for experienced repair technicians only and is not designed for use by the general public. It does not contain warnings or cautions to advise non-technical individuals of potential dangers in attempting to service a product. Products powered by electricity should be serviced or repaired only by experienced professional technicians. Any attempt to service or repair the product or products dealt with in this service information by anyone else could result in serious injury or death.

IMPORTANT SAFETY NOTICE

There are special components used in this equipment which are important for safety. These parts are marked by **⚠** in the Schematic Diagrams, Circuit Board Diagrams, Exploded Views and Replacement Parts List. It is essential that these critical parts should be replaced with manufacturer's specified parts to prevent shock, fire or other hazards. Do not modify the original design without permission of manufacturer.

TABLE OF CONTENTS

	PAGE	PAGE
1 Warning -----	2	
2 Specifications -----	2	
3 Exploded View and Replacement Parts List -----	3	

1 Warning

Caution:

- Pb free solder has a higher melting point than standard solder; Typically the melting point is 50 - 70°F (30 - 40°C) higher. Please use a soldering iron with temperature control and adjust it to 750 ± 20°F (400 ± 10°C). In case of using high temperature soldering iron, please be careful not to heat too long.
- Pb free solder will tend to splash when heated too high (about 1100°F / 600°C).

2 Specifications

Power source	DC 1.5V (one "LR06" Alkaline battery)
Measurement	H:165 X W:20 X D:21 (mm)
Weight	49g (without battery)
Supplied accessory	SEAL (2 pieces for GEL)

3 Exploded View and Replacement Parts List

Model No. : ES-WC30 Exploded View

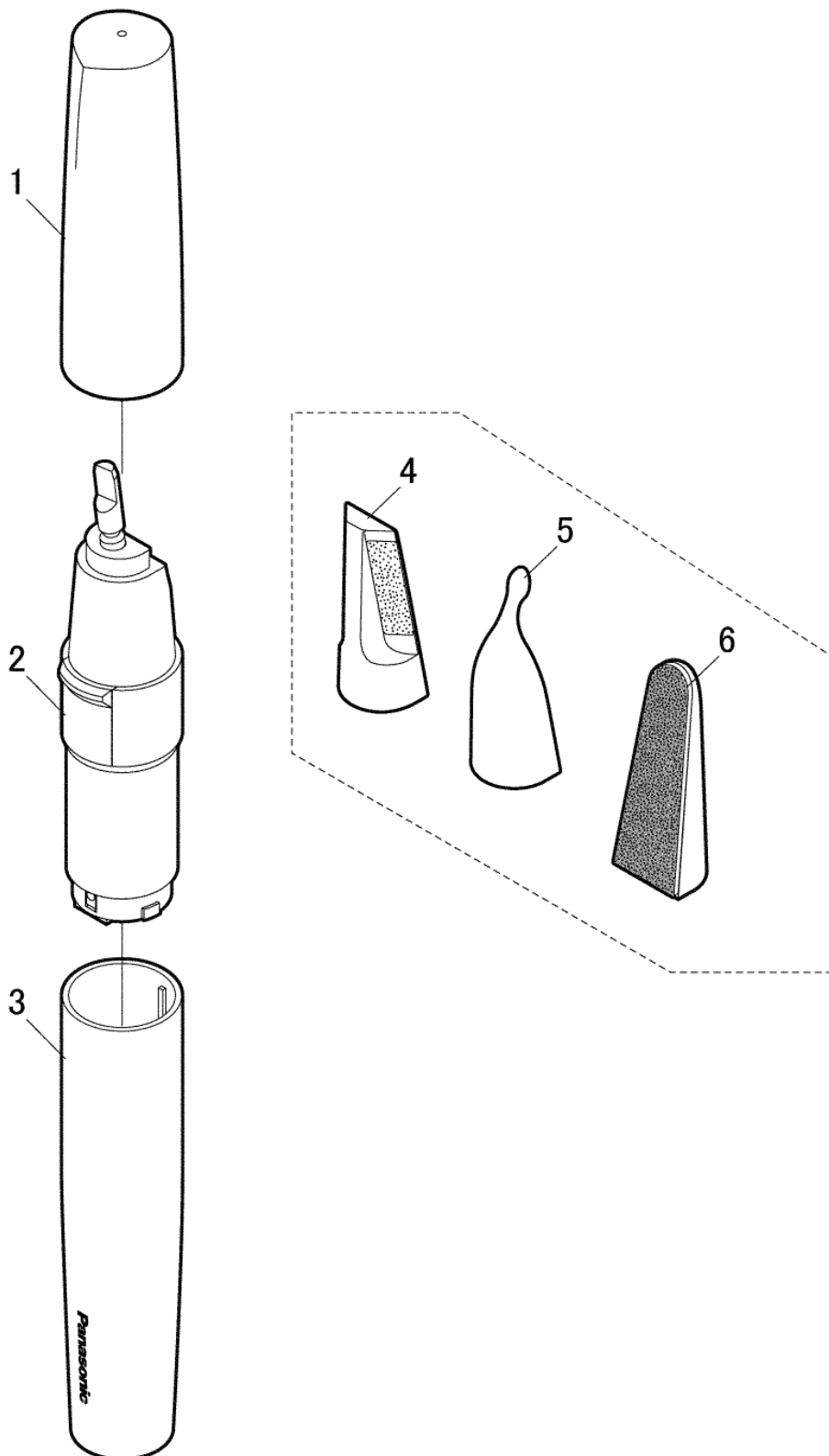

Model No. : ES-WC30 Parts List

Safety	Ref. No.	Part No.	Part Name & Description	Q'ty	Remarks
	1	WESWC30P3187	PROTECTION CAP	1	
	2	WESWC30W4008	BODY BLOCK	1	
	3	WESWC30P3128	BATTERY COVER	1	
	4	WESWC20W4017	FILING ATTACHMENT	1ST	
	5	WESWC20W4027	DECORATION REMOVER & CUTICLE CARE ATTACHMENT	1	
	6	WESWC30W4057	GEL REMOVER ATTACHMENT	1ST	
	-	WES-2C02	SEAL SET	1ST	
	-	WESWC30P8008	INDIVIDUAL BOX	1	
	-	WESWC30P8108	OPERATING INSTRUCTIONS	1	