

Service Manual

Epilator

Model No. **ES-WD74**



Europe
CIS

Please file and use this manual together with the service manual for Model No. ES-WD70, ES-WD60 and ES-WD10, Order No. PCD0902E60CE.

⚠ WARNING

This service information is designed for experienced repair technicians only and is not designed for use by the general public. It does not contain warnings or cautions to advise non-technical individuals of potential dangers in attempting to service a product. Products powered by electricity should be serviced or repaired only by experienced professional technicians. Any attempt to service or repair the product or products dealt with in this service information by anyone else could result in serious injury or death.

IMPORTANT SAFETY NOTICE

There are special components used in this equipment which are important for safety. These parts are marked by ⚠ in the Schematic Diagrams, Circuit Board Diagrams, Exploded Views and Replacement Parts List. It is essential that these critical parts should be replaced with manufacturer's specified parts to prevent shock, fire or other hazards. Do not modify the original design without permission of manufacturer.

TABLE OF CONTENTS

	PAGE		PAGE
1 Warning	2		
2 Specifications	2		
3 Exploded View and Replacement Parts List	3		

1 Warning

Caution:

- Pb free solder has a higher melting point than standard solder; Typically the melting point is 50 - 70°F (30 - 40°C) higher. Please use a soldering iron with temperature control and adjust it to 750 ± 20°F (400 ± 10°C). In case of using high temperature soldering iron, please be careful not to heat too long.
- Pb free solder will tend to splash when heated too high (about 1100°F / 600°C).

2 Specifications

Power source	100-240V AC, 50-60Hz (Automatic voltage conversion)
Charging time	1 hour
Power consumption	Approx. 5W (when charging)
Weight	Approx. 170g with the shaver head
Supplied accessories	Soft case
	Cleaning brush

Model No. : ES-WD74 Exploded View for ES-WD74

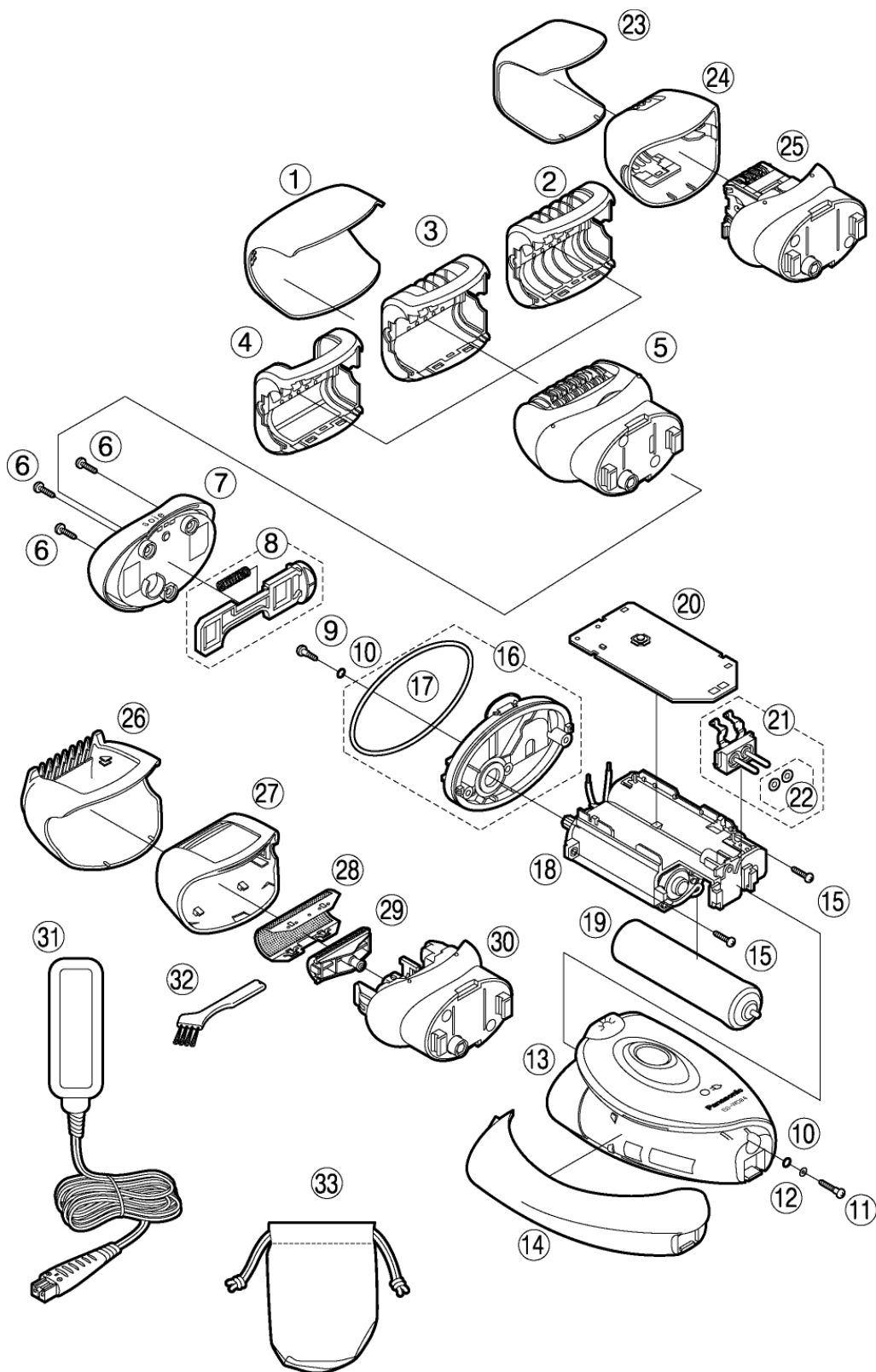

Model No. : ES-WD74 Parts List

Safety	Ref. No.	Part No.	Part Name & Description	Q'ty	Remarks
ES-WD74					
	1	WESWD51X7157	PROTECTION CAP	1	
	2	WESWD52A3108	GENTLE CAP	1	
	3	WESWD52A3118	BEGINNER CAP	1	
	4	WESWD74A3128	FAST CAP	1	
	5	WESWD72W1068	EPILATION HEAD FOR LEGS/ARMS	1	
	6	WESWD51L9397	TAPPING SCREW	3	K2-5
	7	WESWD92W3369	MOUNTING BASE B	1	
	8	WESWD94H3278	HEAD RELEASE BUTTON	1	
	9	WES2047S9707	SCREW	1	K2-8
	10	WER504L0966	O-RING	2	2PCS/PK
	11	WES701S9706	SCREW	1	K2-12
	12	WESWD94L6118	WASHER	1	
	13	WESWD74A3058	HOUSING	1	for CIS
	14	WESWD92W3378	SIDE PANEL	1	
	15	WES331B9257	TAPPING SCREW	2	K2-8
	16	WESWD94L0498	MOUNTING BASE A	1	
	17	WES2067L0997	HOUSING O-RING	1	
	18	WESWD94L1008	MOTOR ASSEMBLY	1	
	19	WESWD70L2508	RECHARGEABLE BATTERY	1	LM-ION TYPE
	20	WESWD94L2108	MODULE	1	
	21	WESWD51L2157	PLUG CHASSIS	1	
	22	WES2047L0327	O-RING A	2	2PCS/PK
	23	WESWD70X7158	PROTECTION CAP	1	
	24	WESWD72W3128	EPILATION HEAD FRAME	1	
	25	WESWD92W1078	EPILATION HEAD FOR UNDERARMS	1	
	26	WESWD51X3557	BIKINI COMB	1	
	27	WESWD51W4037	FOIL FRAME	1	
	28	WES9753Y	OUTER FOIL	1	
	29	WES9752Y	INNER BLADE	1	
	30	WESWD51W0787	SHAVER HEAD	1	
	31	WESWD70W7661	POWER ADAPTOR	1	C-2 PLUG, for CIS
	32	WES2047H6767	CLEANING BRUSH	1	
	33	WESWU41W7008	SOFT CASE	1	
	-	WESWD74P8008	INDIVIDUAL BOX	1	for CIS
	-	WESWD94P8108	OPERATING INSTRUCTIONS	1	for CIS