

# Service Manual

Plasma Television

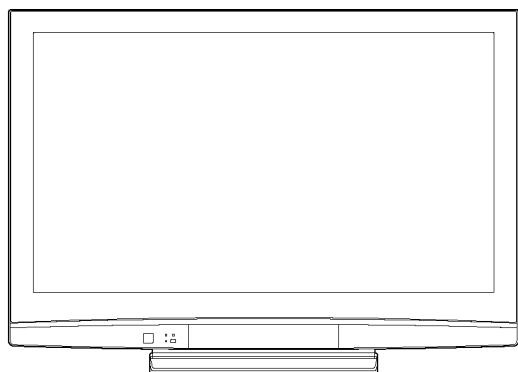

Model No. **TH-42PV8D**  
**TH-42PV8H**  
**TH-42PV8HM**  
**TH-42PV8M**  
**TH-42PV8MR**  
**TH-42PV8MS**  
**TH-42PV8MT**

GPH11DA Chassis

## **⚠ WARNING**

This service information is designed for experienced repair technicians only and is not designed for use by the general public. It does not contain warnings or cautions to advise non-technical individuals of potential dangers in attempting to service a product. Products powered by electricity should be serviced or repaired only by experienced professional technicians. Any attempt to service or repair the product or products dealt with in this service information by anyone else could result in serious injury or death.

# 1 Safety Precautions

## 1.1. General Guidelines

1. When servicing, observe the original lead dress. If a short circuit is found, replace all parts which have been overheated or damaged by the short circuit.
2. After servicing, see to it that all the protective devices such as insulation barriers, insulation papers shields are properly installed.
3. After servicing, make the following leakage current checks to prevent the customer from being exposed to shock hazards.
4. When servicing, observe the original lead dress. If a short circuit is found, replace all parts which have been overheated or damaged by the short circuit.
5. After servicing, see to it that all the protective devices such as insulation barriers, insulation papers shields are properly installed.
6. After servicing, make the following leakage current checks to prevent the customer from being exposed to shock hazards.

## 1.2. Touch-Current Check

1. Plug the AC cord directly into the AC outlet. Do not use an isolation transformer for this check.
2. Connect a measuring network for touch currents between each exposed metallic part on the set and a good earth ground such as a water pipe, as shown in Figure 1.
3. Use Leakage Current Tester (Simpson 228 or equivalent) to measure the potential across the measuring network.
4. Check each exposed metallic part, and measure the voltage at each point.
5. Reserve the AC plug in the AC outlet and repeat each of the above measure.
6. The potential at any point (TOUGH CURRENT) expressed as voltage  $U_1$  and  $U_2$ , does not exceed the following values:

For a. c.:  $U_1 = 35 \text{ V}$  (peak) and  $U_2 = 0.35 \text{ V}$  (peak);

For d. c.:  $U_1 = 1.0 \text{ V}$ ,

**Note:**

The limit value of  $U_2 = 0.35 \text{ V}$  (peak) for a. c. and  $U_1 = 1.0 \text{ V}$  for d. c. correspond to the values  $0.7 \text{ mA}$  (peak) a. c. and  $2.0 \text{ mA}$  d. c.

The limit value  $U_1 = 35 \text{ V}$  (peak) for a. c. correspond to the value  $70 \text{ mA}$  (peak) a. c. for frequencies greater than  $100 \text{ kHz}$ .

7. In case a measurement is out of the limits specified, there is a possibility of a shock hazard, and the equipment should be repaired and rechecked before it is returned to the customer.

### Measuring network for TOUCH CURRENTS

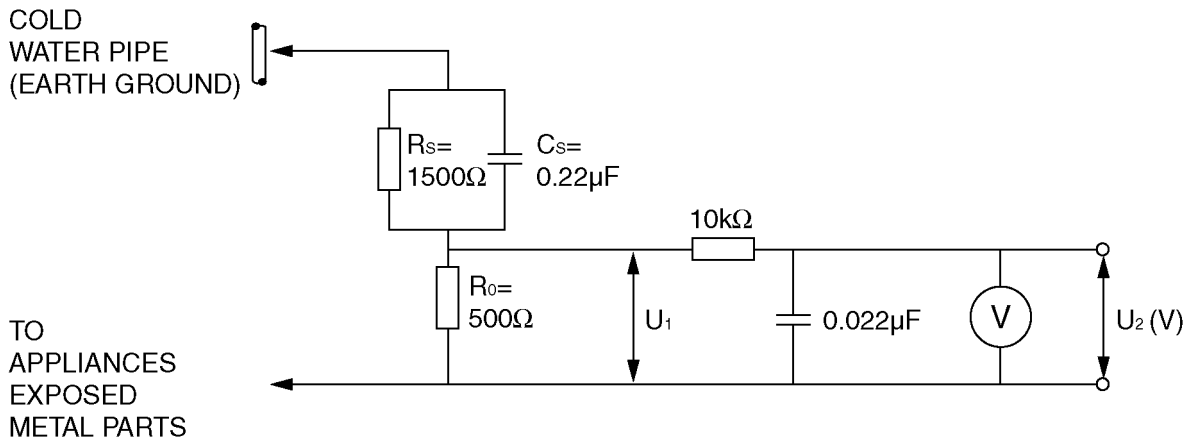

Resistance values in ohms ( $\Omega$ )

V: Voltmeter or oscilloscope  
(r.m.s. or peak reading)

Input resistance:  $\geq 1 \text{ M}\Omega$

Input capacitance:  $\leq 200 \text{ pF}$

Frequency range:  $15 \text{ Hz}$  to  $1 \text{ MHz}$  and d.c. respectively

NOTE - Appropriate measures should be taken to obtain the correct value in case of non-sinusoidal waveforms.

Figure 1

## 2 Warning

### 2.1. Prevention of Electrostatic Discharge (ESD) to Electrostatically Sensitive (ES) Devices

Some semiconductor (solid state) devices can be damaged easily by static electricity. Such components commonly are called Electrostatically Sensitive (ES) Devices. Examples of typical ES devices are integrated circuits and some field-effect transistors and semiconductor [chip] components. The following techniques should be used to help reduce the incidence of component damage caused by electrostatic discharge (ESD).

1. Immediately before handling any semiconductor component or semiconductor-equipped assembly, drain off any ESD on your body by touching a known earth ground. Alternatively, obtain and wear a commercially available discharging ESD wrist strap, which should be removed for potential shock reasons prior to applying power to the unit under test.
2. After removing an electrical assembly equipped with ES devices, place the assembly on a conductive surface such as aluminum foil, to prevent electrostatic charge buildup or exposure of the assembly.
3. Use only a grounded-tip soldering iron to solder or unsolder ES devices.
4. Use only an anti-static solder removal device. Some solder removal devices not classified as [anti-static (ESD protected)] can generate electrical charge sufficient to damage ES devices.
5. Do not use freon-propelled chemicals. These can generate electrical charges sufficient to damage ES devices.
6. Do not remove a replacement ES device from its protective package until immediately before you are ready to install it. (Most replacement ES devices are packaged with leads electrically shorted together by conductive foam, aluminum foil or comparable conductive material).
7. Immediately before removing the protective material from the leads of a replacement ES device, touch the protective material to the chassis or circuit assembly into which the device will be installed.

#### Caution

Be sure no power is applied to the chassis or circuit, and observe all other safety precautions.

8. Minimize bodily motions when handling unpackaged replacement ES devices. (Otherwise ham less motion such as the brushing together of your clothes fabric or the lifting of your foot from a carpeted floor can generate static electricity (ESD) sufficient to damage an ES device).

#### IMPORTANT SAFETY NOTICE

There are special components used in this equipment which are important for safety. These parts are marked by  $\Delta$  in the schematic diagrams, Exploded Views and replacement parts list. It is essential that these critical parts should be replaced with manufacturer's specified parts to prevent shock, fire, or other hazards. Do not modify the original design without permission of manufacturer.

## 2.2. About lead free solder (PbF)

Note: Lead is listed as (Pb) in the periodic table of elements.

In the information below, Pb will refer to Lead solder, and PbF will refer to Lead Free Solder.

The Lead Free Solder used in our manufacturing process and discussed below is (Sn+Ag+Cu).

That is Tin (Sn), Silver (Ag) and Copper (Cu) although other types are available.

This model uses Pb Free solder in it's manufacture due to environmental conservation issues. For service and repair work, we'd suggest the use of Pb free solder as well, although Pb solder may be used.

PCBs manufactured using lead free solder will have the PbF within a leaf Symbol **PbF** stamped on the back of PCB.

### Caution

- Pb free solder has a higher melting point than standard solder. Typically the melting point is 50 ~ 70 °F (30~40 °C) higher. Please use a high temperature soldering iron and set it to 700 ± 20 °F (370 ± 10 °C).

- Pb free solder will tend to splash when heated too high (about 1100 °F or 600 °C).

If you must use Pb solder, please completely remove all of the Pb free solder on the pins or solder area before applying Pb solder. If this is not practical, be sure to heat the Pb free solder until it melts, before applying Pb solder.

- After applying PbF solder to double layered boards, please check the component side for excess solder which may flow onto the opposite side. (see figure below)

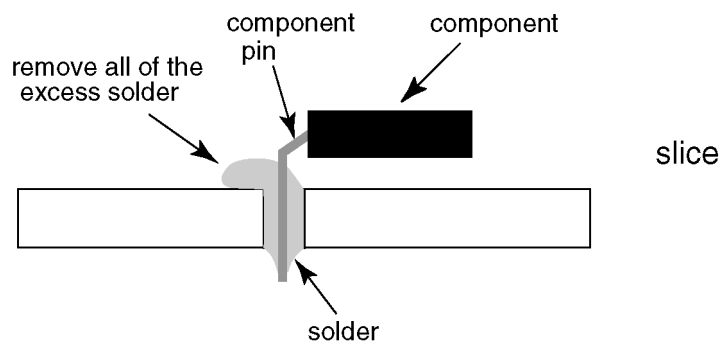

### Suggested Pb free solder

There are several kinds of Pb free solder available for purchase. This product uses Sn+Ag+Cu (tin, silver, copper) solder. However, Sn+Cu (tin, copper), Sn+Zn+Bi (tin, zinc, bismuth) solder can also be used.

0.3mm X 100g	0.6mm X 100g	1.0mm X 100g



# 3 Service Navigation

## 3.1. Service Hint

[How to set the plasma unit for servicing]  
Place the plasma unit on the pedestal stand.

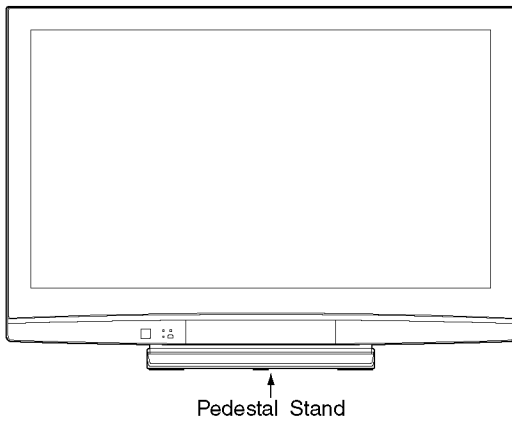

Remove the Rear Cover.

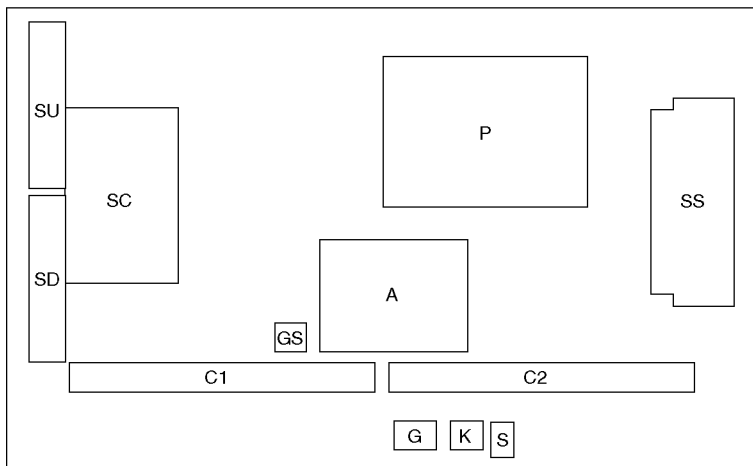
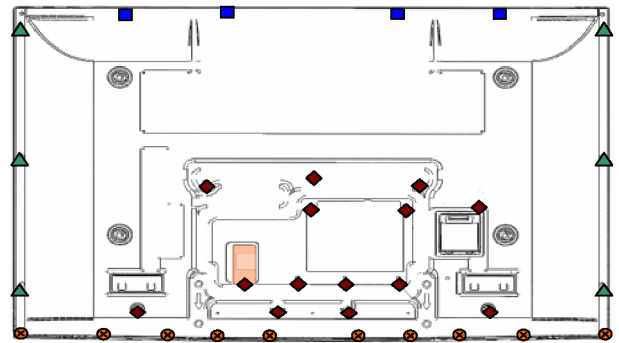

Remove : 4 screw ( ■ ) XYN4+F10FJK  
6 screw ( ▲ ) XYN4+F30FJK  
10screw ( ● ) XTB4+12GFJK  
14screw ( ◆ ) THEL0429

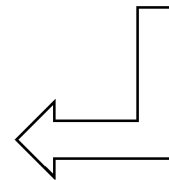

Board Name	Function	Board Name	Function
P	Power Supply	C1	Data Driver (Lower Right)
A	DC-DC Converter Speaker out, Sound Processor AV Terminal, AV Switch Digital Signal Processor, Micon, HDMI Interface Peaks Lite 2p Format Converter, Plasma AI, Sub-Field Processor	C2	Data Driver (Lower Left)
K	Remote receiver, Power LED	SC	Scan Drive
S	Power Switch	SU	Scan out (Upper)
		SD	Scan out (Lower)
		SS	Sustain Drive
		G	Key Switch, Front Terminal
		GS	SD Card Slot

## 3.2. Applicable signals

### COMPONENT (Y, P<sub>B</sub>/C<sub>B</sub>, P<sub>R</sub>/C<sub>R</sub>), HDMI

\* Mark: Applicable input signal

Signal name	COMPONENT	HDMI
525 (480) / 60i	*	*
525 (480) / 60p	*	*
625 (576) / 50i	*	*
625 (576) / 50p	*	*
750 (720) / 60p	*	*
750 (720) / 50p	*	*
1,125 (1,080) / 60i	*	*
1,125 (1,080) / 50i	*	*
1,125 (1,080) / 60p		*
1,125 (1,080) / 50p		*
1,125 (1,080) / 24p		*

### PC (D-sub 15P)

Signal name	Horizontal frequency (kHz)	Vertical frequency (Hz)
640 × 400 @70 Hz	31.47	70.07
640 × 480 @60 Hz	31.47	59.94
640 × 480 @75 Hz	37.50	75.00
800 × 600 @60 Hz	37.88	60.32
800 × 600 @75 Hz	46.88	75.00
800 × 600 @85 Hz	53.67	85.06
852 × 480 @60 Hz	31.44	59.89
1,024 × 768 @60 Hz	48.36	60.00
1,024 × 768 @70 Hz	56.48	70.07
1,024 × 768 @75 Hz	60.02	75.03
1,024 × 768 @85 Hz	68.68	85.00
1,280 × 1,024 @60 Hz	63.98	60.02
1,366 × 768 @60 Hz	48.39	60.04
Macintosh13" (640 × 480)	35.00	66.67
Macintosh16" (832 × 624)	49.73	74.55
Macintosh21" (1,152 × 870)	68.68	75.06

#### Note

- Signals other than above may not be displayed properly.
- The above signals are reformatted for optimal viewing on your display.
- Applicable input signal for PC is basically compatible to VESA standard timing.
- PC signal is magnified or compressed for display, so that it may not be possible to show fine detail with sufficient clarity.

# 4 Specifications

**Power Source** AC 220 - 240 V, 50/60 Hz (D/H/HM/M/MR/MT)  
**Power Consumption** AC 110 - 240 V, 50/60 Hz (MS)  
**Average use** 335 W (D/H/HM/M/MR/MT)  
 340 W (MS)  
**Standby condition** 0.7 W  
**Plasma Display panel**  
**Aspect Ratio** 16:9  
**Visible screen size** 106 cm (diagonal)  
 922 mm (W) × 518 mm (H)  
**Number of pixels** 786,432 (1,024 (W) × 768 (H)) [3,072 × 768 dots]  
**Sound**  
**Speaker** 160 mm × 42 mm × 2 pcs, 8 Ω  
**Audio Output** 20 W (10 W + 10 W), 10% THD  
**Headphones** M3 (3.5 mm) stereo mini Jack × 1  
**PC signals** VGA, SVGA, XGA  
 SXGA ..... (compressed)  
 Horizontal scanning frequency 31 - 69 kHz  
 Vertical scanning frequency 59 - 86 Hz

**Receiving Systems / Band name**

17 Systems	Function	17 Systems	Function
1 PAL B, G, H	Reception of broadcast transmissions and Playback from Video Cassette Tape Recorders	8 NTSC 4.43/5.5 MHz	Playback from Special VCR's or DVD
2 PAL I		9 NTSC 4.43/6.0 MHz	
3 PAL D, K		10 NTSC 4.43/6.5 MHz	
4 SECAM B, G		11 NTSC 3.58/5.5 MHz	
5 SECAM D, K		12 NTSC 3.58/6.0 MHz	
6 SECAM K1		13 NTSC 3.58/6.5 MHz	
7 NTSC M (NTSC 3.58/4.5 MHz)		14 SECAM I	
	15 PAL 60 Hz/5.5 MHz		
	16 PAL 60 Hz/6.0 MHz		
	17 PAL 60 Hz/6.5 MHz		

**Receiving Channels**  
(Regular TV)

**VHF BAND**

2 - 12 (PAL/SECAM B, K1)  
 0 - 12 (PAL B AUST.)  
 1 - 9 (PAL B N.Z.)  
 1 - 12 (PAL/SECAM D)  
 1 - 12 (NTSC M Japan)  
 2 - 13 (NTSC M USA)

**UHF BAND**

21 - 69 (PAL G, H, I/SECAM G, K, K1)  
 28 - 69 (PAL B AUST.)  
 13 - 57 (PAL D, K)  
 13 - 62 (NTSC M Japan)  
 14 - 69 (NTSC M USA)

**CATV**

S1 - S20 (OSCAR)  
 1 - 125 (USA CATV)  
 C13 - C49 (JAPAN)  
 S21 - S41 (HYPER)  
 Z1 - Z37 (CHINA)  
 5A, 9A (AUST.)

**Aerial - Rear**

VHF/UHF

**Operating Conditions**

**Temperature:**

0 °C - 40 °C

**Humidity:**

20 % - 80 % RH (non-condensing)

**Connection Terminals**

**AV1 Input**

**AUDIO L - R**  
**VIDEO**  
**COMPONENT**

RCA PIN Type × 2  
 RCA PIN Type × 1  
 Y  
 P<sub>B</sub>/C<sub>B</sub>, P<sub>R</sub>/C<sub>R</sub>

0.5 V [rms]  
 1.0 V [p-p] (75 Ω)  
 1.0 V [p-p] ((including synchronization)  
 ± 0.35 V [p-p]

**AV2 Input**

**AUDIO L - R**  
**VIDEO**  
**COMPONENT**

RCA PIN Type × 2  
 RCA PIN Type × 1  
 Y  
 P<sub>B</sub>/C<sub>B</sub>, P<sub>R</sub>/C<sub>R</sub>

0.5 V [rms]  
 1.0 V [p-p] (75 Ω)  
 1.0 V [p-p] ((including synchronization)  
 ± 0.35 V [p-p]

**AV3 Input**

**AUDIO L - R**  
**VIDEO**  
**S VIDEO**

RCA PIN Type × 2  
 RCA PIN Type × 1  
 Mini DIN 4-pin

0.5 V [rms]  
 1.0 V [p-p] (75 Ω)  
 Y:1.0 V [p-p] (75 Ω) C:0.286 V [p-p] (75 Ω)

**AV4 Input**

**AUDIO L - R**  
**VIDEO**  
**S VIDEO**

RCA PIN Type × 2  
 RCA PIN Type × 1  
 Mini DIN 4-pin

0.5 V [rms]  
 1.0 V [p-p] (75 Ω)  
 Y:1.0 V [p-p] (75 Ω) C:0.286 V [p-p] (75 Ω)

<b>Monitor Output</b>		
<b>AUDIO L - R</b>	RCA PIN Type × 2	0.5 V [rms] (high impedance)
<b>VIDEO</b>	RCA PIN Type × 1	1.0 V [p-p] (75 Ω)
<b>Others</b>		
<b>HDMI1 / 2 Input</b>	TYPE A Connectors	This TV supports [HDAVI Control 3] function.
<b>PC Input</b>	HIGH-DENSITY D-SUB 15PIN	R, G, B/ 0.7 V [p-p] (75 Ω) HD, VD/TTL Level 2.0 - 5.0 V [p-p] (high impedance)
<b>Card slot</b>	SD Card slot × 1 (Factory use)	
<b>Dimensions (W × H × D)</b>	1,020 mm × 727 mm × 327 mm (With Pedestal)	
	1,020 mm × 679 mm × 95 mm (TV only)	
<b>Mass</b>	27.5 kg Net (With Pedestal)	
	25.5 kg Net (TV only)	

**Note**

- Design and Specifications are subject to change without notice. Mass and Dimensions shown are approximate.

# 5 Service Mode

## 5.1. How to enter into Service Mode

While pressing [VOLUME ( - )] button of the main unit, press [0] button of the remote control three times within 2 seconds.

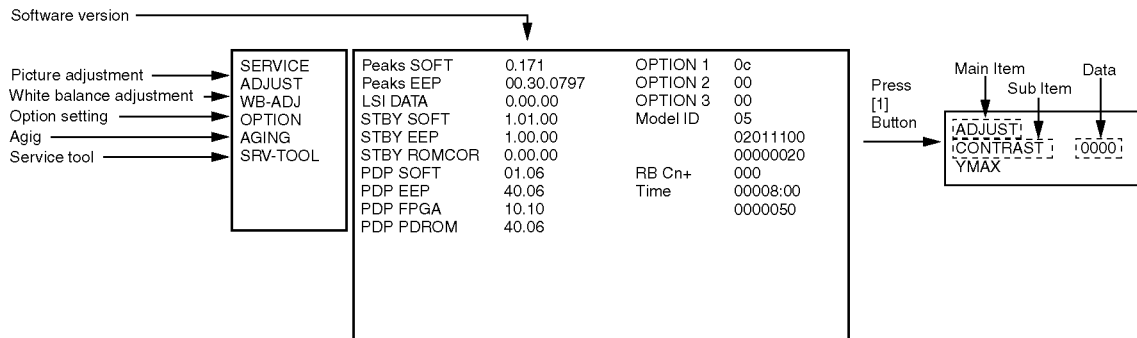

### 5.1.1. Key command

- [1] button...Main items Selection in forward direction
- [2] button...Main items Selection in reverse direction
- [3] button...Sub items Selection in forward direction
- [4] button...Sub items Selection in reverse direction
- [RED] button...All Sub items Selection in forward direction
- [GREEN] button...All Sub items Selection in reverse direction
- [VOL] button...Value of sub items change in forward direction ( + ), in reverse direction ( - )

### 5.1.2. Contents of adjustment mode

- Value is shown as a hexadecimal number.
- Preset value differs depending on models.
- After entering the adjustment mode, take note of the value in each item before starting adjustment.

Main item	Sub item	Sample data	Remark
ADJUST	CONTRAST	IE3	
	COLOR	2B	
	TINT	00	
	SUB-BRT	810	
	H-POS	0	
	H-AMP	0	
	V-POS	0	
	V-AMP	0	
WB-ADJ	R-CUT	80	
	G-CUT	80	
	B-CUT	80	
	R-DRV	FC	
	G-DRV	EE	
	B-DRV	FB	
	ALL-CUT	80	
	ALL-DRV	FC	
OPTION	Panel-Type	42HD	Factory Preset
	Boot	ROM	
	STBY-SET	00	
	EMERGENCY	ON	
	Y/C Delay	-1	
	OPT 1	10001000	
	OPT 2	11100010	
	OPT 3	10101111	
AGING	RGBW		
	All white (COUNTER)		
	All white		
	All red		
	All green		
	All blue		
	ON/OFF		
	Diagonal lamp W		
	Diagonal lamp R		
	Diagonal lamp G		
	Diagonal lamp B		
	1% WINDOW		
	COLOR BAR		
	A B zone/checkerd 4 trio		
	SCROLL BAR		
2dot width border			
SRV-TOOL			see next

Destinations	D/H/HM/M/MR/MT	MS
OPTION1	88	88
OPTION2	e2	e2
OPTION3	6f	ef

### 5.1.3. How to exit

Switch off the power with the [POWER] button on the main unit or the [POWER] button on the remote control.

## 5.2. Service tool mode

### 5.2.1. How to access

1. Select [SRV-TOOL] in Service Mode.
2. Press [OK] button on the remote control.

SRV-TOOL	
Display of TD2Microcode version →	TD2Microcode:81c00011
Display of Flash ROM maker code →	Flash ROM : 1 - 227E
Display of SOS History →	PTCT : 00 . 00 . 00 . 00 . 00
	Time 00000:40      Count 0000022 ← POWER ON TIME/COUNT Press [MUTE] button (3sec)

### 5.2.2. Display of SOS History

SOS History (Number of LED blinking) indication.

From left side; Last SOS, before Last, three occurrence before, 2nd occurrence after shipment, 1st occurrence after shipment.  
This indication will be cleared by [Self-check indication and forced to factory shipment setting].

### 5.2.3. POWER ON TIME/COUNT

To display TIME/COUNT menu, highlight position, then press MUTE for 3sec.

Time : Cumulative power on time, indicated hour : minute by decimal

Count : Number of On times by decimal

Note : This indication will not be cleared by either of the self-checks or any other command.

### 5.2.4. Exit

1. Disconnect the AC cord from wall outlet or switch off the power with the [POWER] button on the main unit.

### 5.3. Hotel mode

1. Purpose

Restrict a function for hotels.

2. Access command to the Hotel mode setup menu

In order to display the Hotel mode setup menu, please enter the following command (**within 2 second**).

[TV] : Vol. [Down] + [REMOTE] : AV (3 times)

Then, the Hotel mode setup menu is displayed.

Hotel Mode	
Hotel Mode	Off
Initial INPUT	Off
Initial POS	Off
Initial VOL Level	Off
Maximum Vol Level	100
Button Lock	Off
Remote Lock	Off
Select	

3. To exit the Hotel mode setup menu

Disconnect AC power cord from wall outlet or switch off the power with the [POWER] button on the main unit.

4. Explain the Hotel mode setup menu

item	Function
Hotel Mode	Select hotel mode ON/OFF
Initial INPUT	Select input signal modes. Set the input, when each time power is switched on. Selection : Off/TV/AV1/AV2/AV3/AV4/PC/HDMI1/HDMI2 • Off: give priority to a last memory. However, Euro model is compulsorily set to TV. • AVnS/AVnC: only Euro model selectable • PC: selectable with VGA option
Initial POS	Select programme number. Selection : Off/0 to 99 • Off: give priority to a last memory
Initial VOL level	Adjust the volume when each time power is switched on. Selection/Range : Off/0 to 63 • Off: give priority to a last memory
Maximum VOL level	Adjust maximum volume. Range : 0 to 100
Button lock	Select local key conditions. Selection : Off/SETUP/MENU/All • Off: altogether valid • SETUP: only F-key is invalid (Tuning guide(menu) can not be selected.) • MENU: only F-key is invalid (only Volume/Mute can be selected.) • ALL: altogether invalid.
Remote lock	Select remote control key conditions. Selection : Off/SETUP/MENU • Off: altogether valid • SETUP: only Setup menu is invalid • MENU: Picture/Sound/Setup menu are invalid



# 6 Troubleshooting Guide

Use the self-check function to test the unit.

1. Checking the IIC bus lines
2. Power LED Blinking timing

## 6.1. Check of the IIC bus lines

### 6.1.1. How to access

Self-check indication only:

Produce TV reception screen, and while pressing [VOLUME (-)] button on the main unit, press [OK] button on the remote control for more than 3 seconds.

Self-check indication and forced to factory shipment setting:

Produce TV reception screen, and while pressing [VOLUME (-)] button on the main unit, press [MENU] button on the remote control for more than 3 seconds.

### 6.1.2. Screen display

42HD SET	Panasonic 2008PDP  SELF CHECK COMPLETE																																																									
<table border="1" style="width: 100%; border-collapse: collapse;"> <tr><td>ADV</td><td>OK</td></tr> <tr><td>ADAV</td><td>OK</td></tr> <tr><td>TUN</td><td>OK</td></tr> <tr><td>GENX</td><td>OK</td></tr> <tr><td>MEN1</td><td>OK</td></tr> <tr><td>MEN2</td><td>OK</td></tr> <tr><td>AVSW</td><td>OK</td></tr> <tr><td>PDP-PANEL</td><td>OK</td></tr> <tr><td>TEMP</td><td>OK</td></tr> </table>	ADV	OK	ADAV	OK	TUN	OK	GENX	OK	MEN1	OK	MEN2	OK	AVSW	OK	PDP-PANEL	OK	TEMP	OK	<table border="1" style="width: 100%; border-collapse: collapse;"> <tr><td>PEAKS-SOFT</td><td>0.171</td></tr> <tr><td>PEAKS-EEP</td><td>00.30.0797</td></tr> <tr><td>GENX-SOFT</td><td>1.01.00</td></tr> <tr><td>GENX-EEP</td><td>1.00.00</td></tr> <tr><td>GENX-ROMCOR</td><td>0.00.00</td></tr> <tr><td>PDP-MCU</td><td>01.06</td></tr> <tr><td>PDP-EEP</td><td>40.06</td></tr> <tr><td>PDP-FPGA</td><td>10.10</td></tr> <tr><td>PDP-PD2-M</td><td>40.06</td></tr> </table>	PEAKS-SOFT	0.171	PEAKS-EEP	00.30.0797	GENX-SOFT	1.01.00	GENX-EEP	1.00.00	GENX-ROMCOR	0.00.00	PDP-MCU	01.06	PDP-EEP	40.06	PDP-FPGA	10.10	PDP-PD2-M	40.06	<table border="1" style="width: 100%; border-collapse: collapse;"> <tr><td>SUM</td><td>1f40</td></tr> <tr><td>OPTION 1</td><td>0c</td></tr> <tr><td>OPTION 2</td><td>00</td></tr> <tr><td>OPTION 3</td><td>00</td></tr> <tr><td>Check</td><td>0c</td></tr> <tr><td>Model ID</td><td>05</td></tr> <tr><td></td><td>02201100</td></tr> <tr><td></td><td>00000020</td></tr> <tr><td>EDID1</td><td>c6.f5</td></tr> <tr><td>EDID2</td><td>c6.e5</td></tr> </table>	SUM	1f40	OPTION 1	0c	OPTION 2	00	OPTION 3	00	Check	0c	Model ID	05		02201100		00000020	EDID1	c6.f5	EDID2	c6.e5
ADV	OK																																																									
ADAV	OK																																																									
TUN	OK																																																									
GENX	OK																																																									
MEN1	OK																																																									
MEN2	OK																																																									
AVSW	OK																																																									
PDP-PANEL	OK																																																									
TEMP	OK																																																									
PEAKS-SOFT	0.171																																																									
PEAKS-EEP	00.30.0797																																																									
GENX-SOFT	1.01.00																																																									
GENX-EEP	1.00.00																																																									
GENX-ROMCOR	0.00.00																																																									
PDP-MCU	01.06																																																									
PDP-EEP	40.06																																																									
PDP-FPGA	10.10																																																									
PDP-PD2-M	40.06																																																									
SUM	1f40																																																									
OPTION 1	0c																																																									
OPTION 2	00																																																									
OPTION 3	00																																																									
Check	0c																																																									
Model ID	05																																																									
	02201100																																																									
	00000020																																																									
EDID1	c6.f5																																																									
EDID2	c6.e5																																																									

### 6.1.3. Check Point

Confirm the following parts if NG was displayed.

Display	Ref. No.	Description	P.C.B.
ADV	IC4510	AD/HDMI	A-Board
ADAV	IC2106	Sound Processor	A-Board
TUN	TU8301	Tuner	A-Board
GEN	IC1100	GenX (STB MCU)	A-Board
MEM1	IC1101	EEPROM (GenX)	A-Board
MEM2	IC8601	EEPROM (Peaks)	A-Board
AVSW	IC3001	Audio/Video SW	A-Board
PDP-PANEL	IC9003	MICOM	A-Board
TEMP	IC4800	Temp Sensor	A-Board

### 6.1.4. Exit

Disconnect the AC cord from wall outlet or switch off the power with the [POWER] button on the main unit.

## 6.2. Power LED Blinking timing chart

### 1. Subject

Information of LED Flashing timing chart.

### 2. Contents

When an abnormality has occurred the unit, the protection circuit operates and reset to the stand by mode. At this time, the defective block can be identified by the number of blinks of the Power LED on the front panel of the unit.

Blinking Times	Blinking timing	Contents	Check point
1	<p>Once 3 sec</p> <p>Light No Light</p>	No particular check point	-
2		15V SOS	P-Board
3		3.3V SOS	A-Board
4		Power SOS	P-Board
5		5V SOS	P-Board A-Board
6		Driver SOS1 (SC Energy recovery circuit)	SU-Board SD-Board SC-Board
7		Driver SOS2 (SC floating voltage area)	SU-Board SD-Board SC-Board
8		Driver SOS3 (SS Energy recovery circuit)	SS-Board
9		Config SOS	-
10		Sub 5V SOS Main 3.3V SOS DTV 9V SOS Tuner Power SOS	A-Board
12		Sound SOS	P-Board A-Board
13		Communication Error with IC8001 (Peaks Lite2)	A-Board

### 6.3. No Power

First check point

There are following 2 states of No Power indication by power LED.

1. No lit
2. Red is lit then turns red blinking a few seconds later. (See 6.2.)

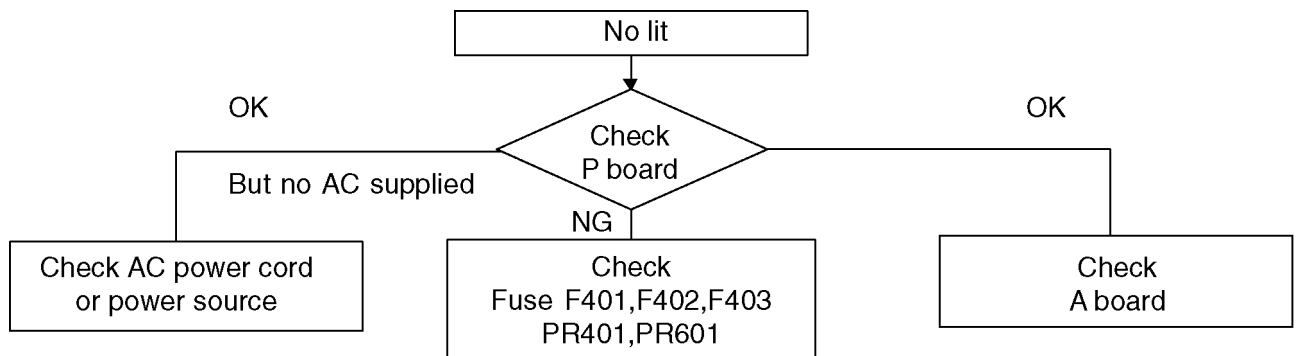

## 6.4. No Picture

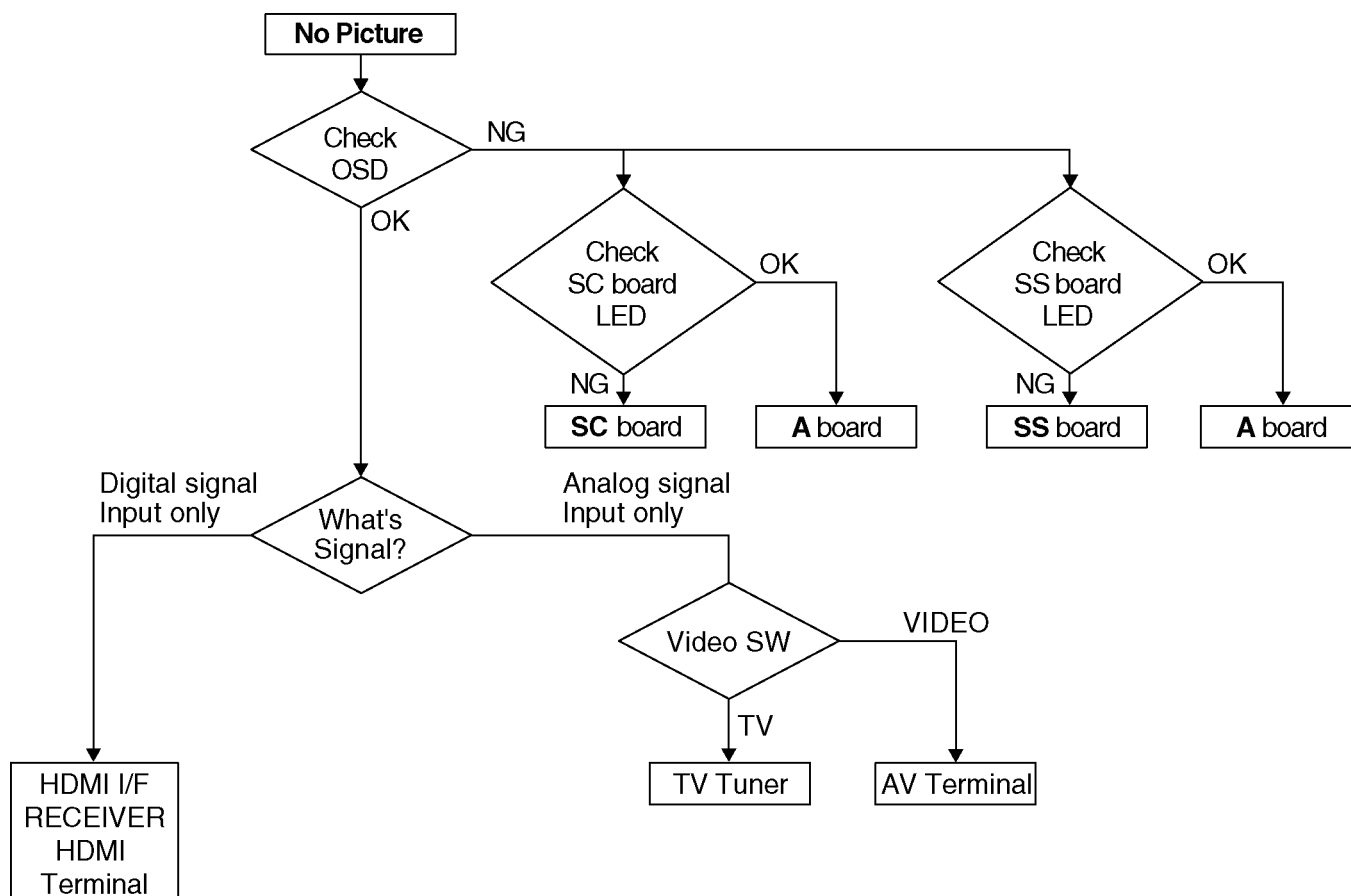

Drive circuits LED indicator

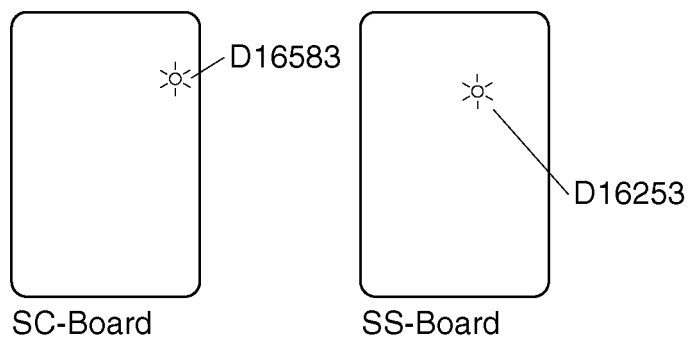

## 6.5. Local screen failure

Plasma display may have local area failure on the screen. Fig-1 is the possible defect P.C.B. for each local area.

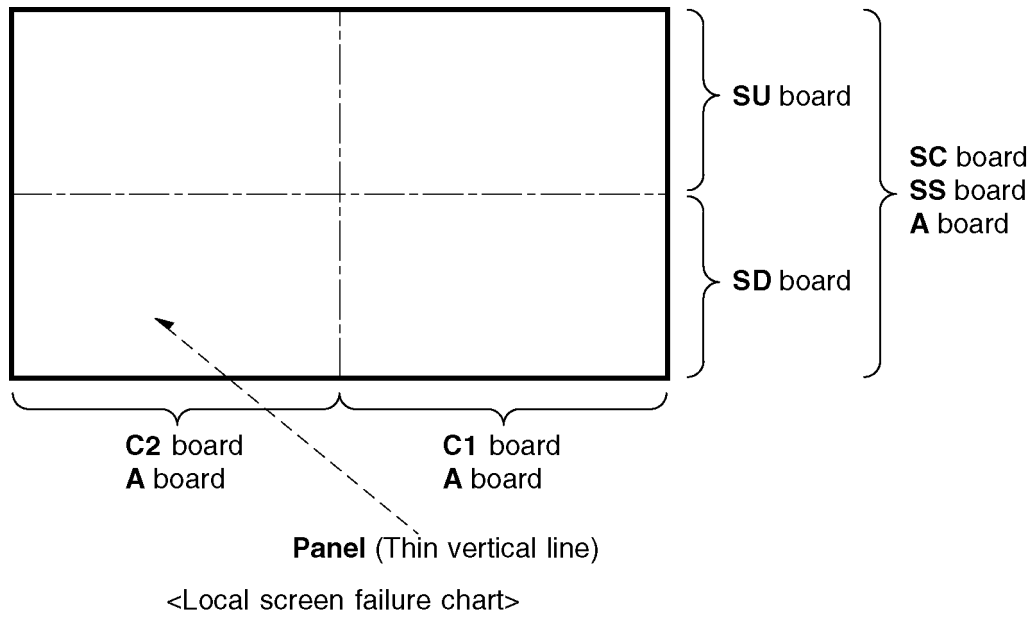

Fig-1

# 7 Disassembly and Assembly Instructions

## 7.1. Remove the rear cover

1. See Service Hint (Section 3)

## 7.2. Remove the P-Board

### Caution:

To remove P.C.B. wait 1 minute after power was off for discharge from electrolysis capacitors.

1. Unlock the cable clampers to free the cable.
2. Disconnect the connectors (P2, P6, P7, P9, P11, P12 and P25).
3. Remove the screws (×10 ➡) and remove the P-Board.

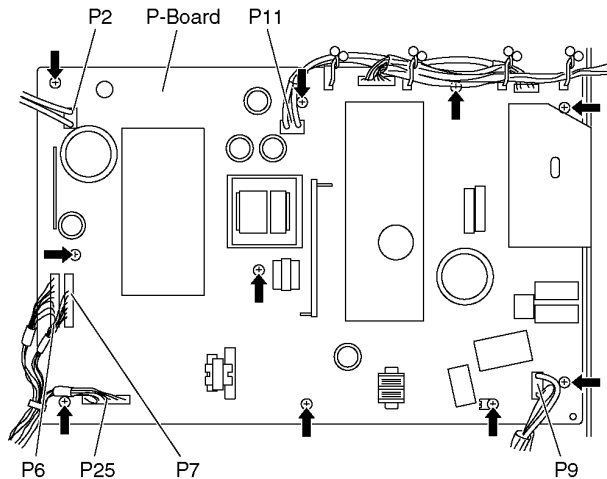

## 7.3. Remove the rear terminal cover

1. Remove the screws (×2 ⇐, ×2 ➡).
2. Remove the rear terminal cover.

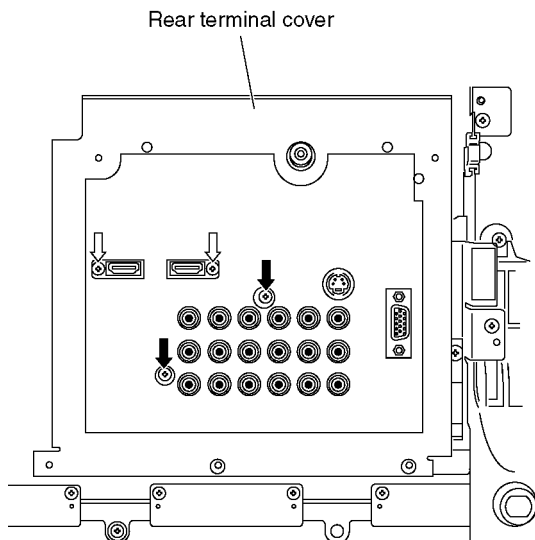

## 7.4. Remove the Tuner unit

1. Unlock the cable clampers to free the cable.
2. Disconnect the connectors (A1, A7, A11, A12, A25, A31, A32, A51, A52).
3. Remove the screws (×4 ➡, ×1 ⇐) and remove the tuner unit.

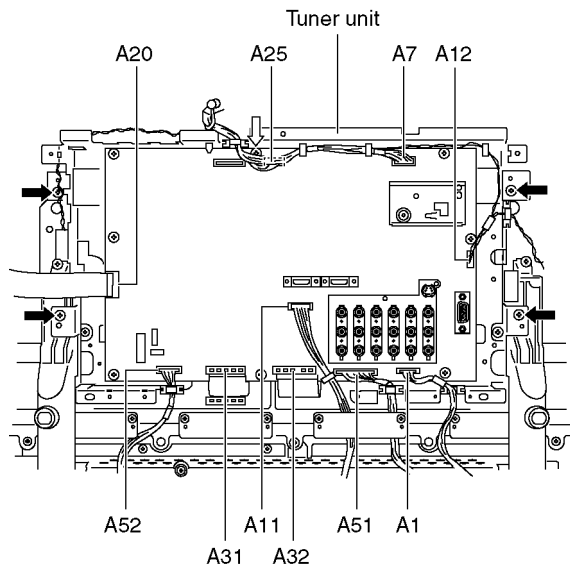

## 7.5. Remove the GS-Board

1. Disconnect the connector (GS52).
2. Remove the screw (➡) and remove the rear SD bracket.

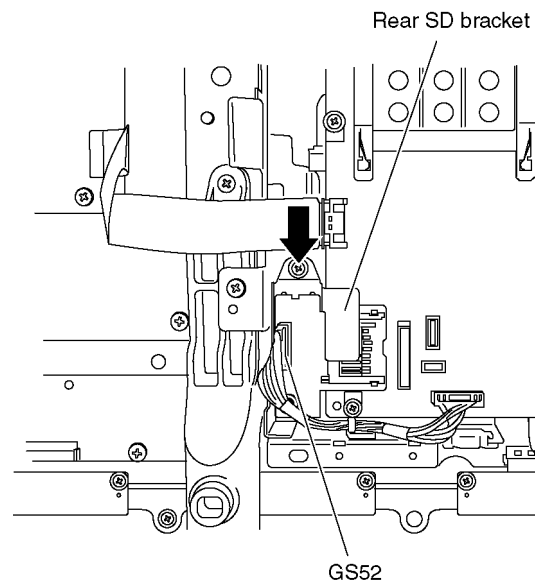

3. Remove the screw (➡) and remove the GS-Board.

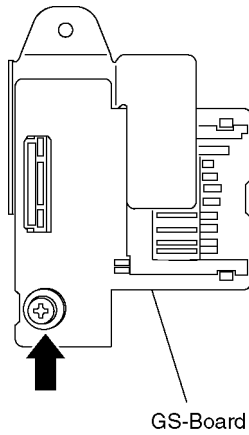

### 7.6. Remove the A-Board

1. Remove the tuner unit. (See section 7.4.)
2. Remove the screws (x7 ➡) and remove the A-Board.

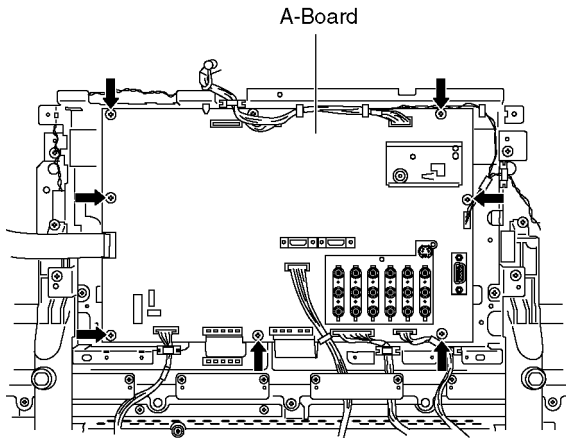

### 7.7. Remove the SU-Board

1. Remove the flexible cables (SU1, SU2, SU3 and SU4) connected to the SU-Board.
2. Remove the flexible cable (SU11-SD11) and the bridge connector (SC41-SU41).
3. Remove the screws (x2 ➡, x2 ⇨) and remove the SU-Board.

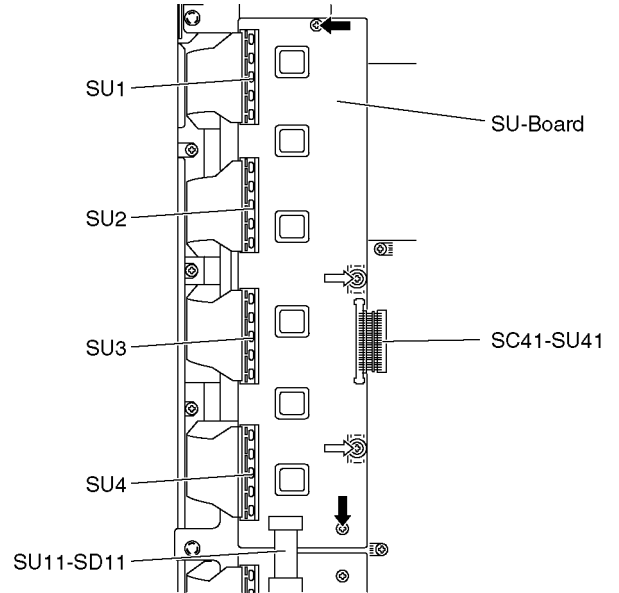

### 7.8. Remove the SD-Board

1. Remove the flexible cables (SD1, SD2, SD3 and SD4) connected to the SD-Board.
2. Remove the flexible cable (SU11-SD11) and the bridge connectors (SC42-SD42 and SC46-SD46).
3. Remove the screws (x2 ➡, x2 ⇨) and remove the SD-Board.

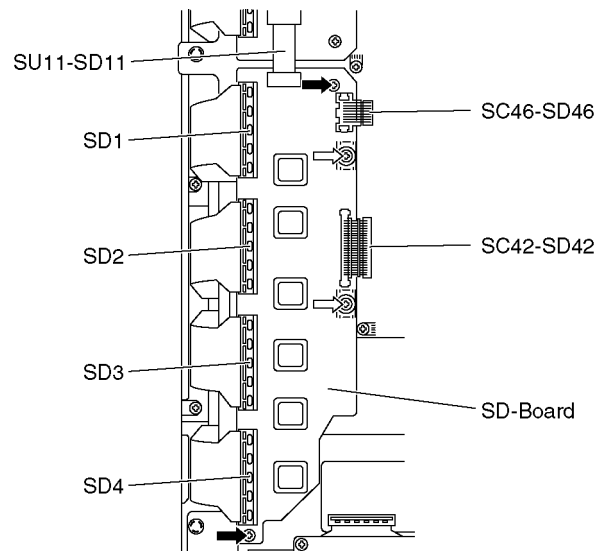

## 7.9. Remove the SC-Board

1. Remove the SU-Board and SD-Board. (See section 7.7. and 7.8.)
2. Unlock the cable clampers to free the cable.
3. Disconnect the connector (SC2).
4. Disconnect the flexible cable (SC20).
5. Remove the screws (×6 ➡) and remove the SC-Board.

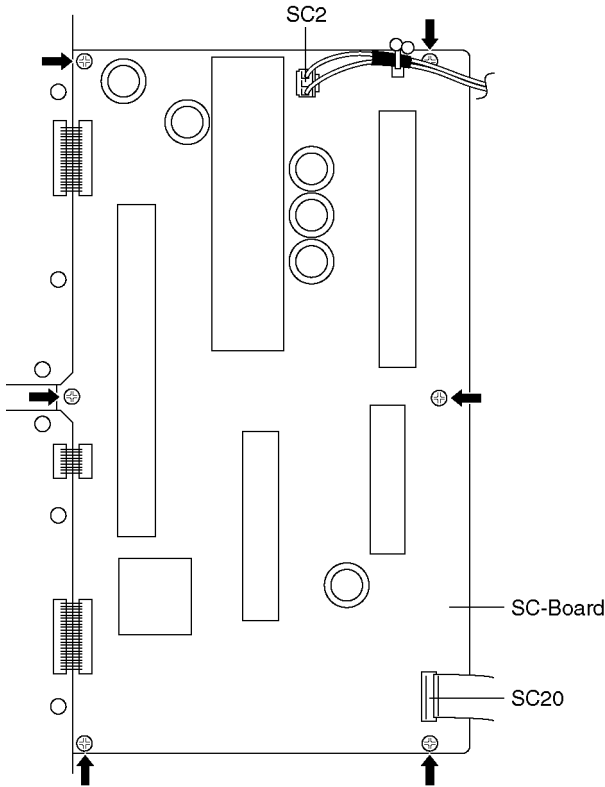

## 7.10. Remove the SS-Board

1. Unlock the cable clampers to free the cable.
2. Disconnect the connectors (SS11, SS12, SS23 and SS34).
3. Disconnect the flexible cables (SS53A and SS56A).
4. Remove the molding prop (×1 ⇨).
5. Remove the screws (×5 ➡) and remove the SS-Board.

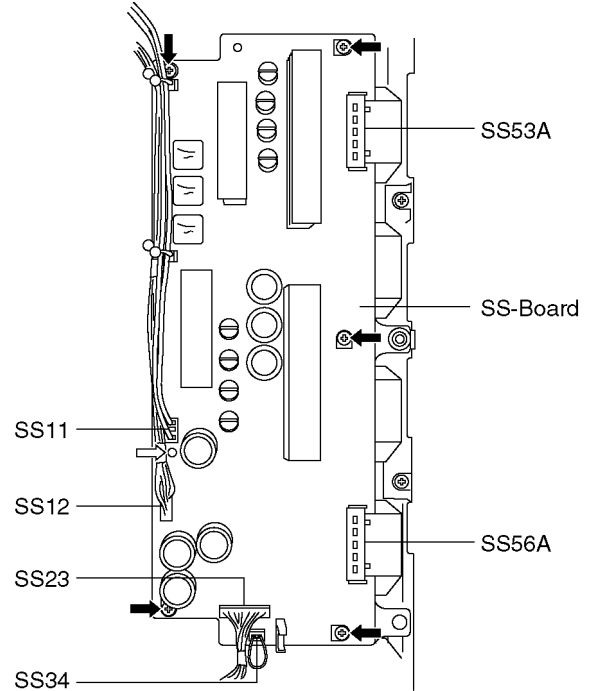

## 7.11. Remove the stand brackets

1. Remove the plasma panel section from the servicing stand and lay on a flat surface such as a table (covered) with the plasma panel surface facing downward.
2. Remove the stand brackets (left, right) fastening screws (×4 ➡ each) and remove the stand brackets (left, right).

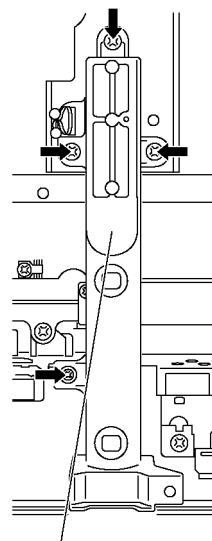

Stand bracket R

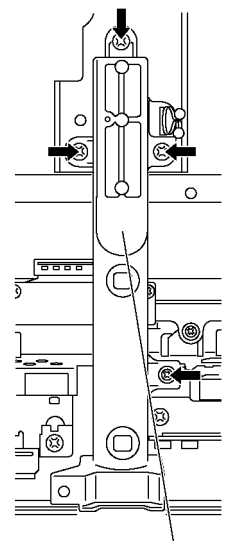

Stand bracket L



## 7.12. Remove the C1-Board

1. Remove the tuner unit. (See section 7.4.)
2. Unlock the cable clampers to free the cable.
3. Remove the flexible cables holder fastening screws (×8 ⇨).
4. Disconnect the flexible cables (CB1, CB2, CB3 and CB4).
5. Disconnect the flexible cables (C10 and C11).
6. Remove the screws (×4 ⇨) and remove the C1-Board.

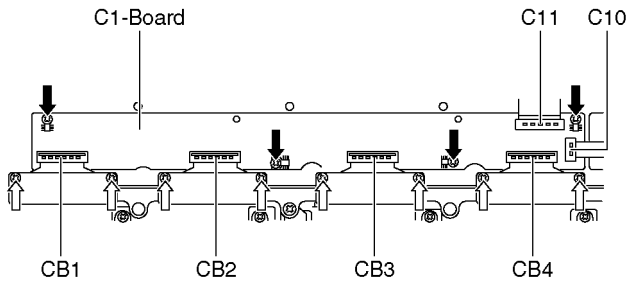

## 7.13. Remove the C2-Board

1. Remove the tuner unit. (See section 7.4.)
2. Unlock the cable clampers to free the cable.
3. Remove the flexible cables holder fastening screws (×8 ⇨).
4. Disconnect the flexible cables (CB5, CB6, CB7 and CB8).
5. Disconnect the flexible cables (C20 and C21).
6. Disconnect the connector (C23).
7. Remove the screws (×4 ⇨) and remove the C2-Board.

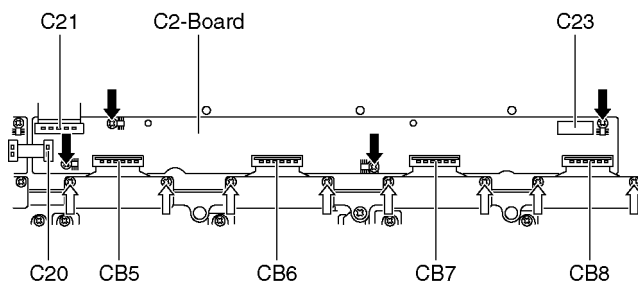

## 7.14. Remove the front shield unit assy

1. Disconnect the connector (A11, A51 and A52). (See section 7.4.)
2. Remove the screws (×2 ⇨, ×2 ⇨) and remove the front shield unit assy.

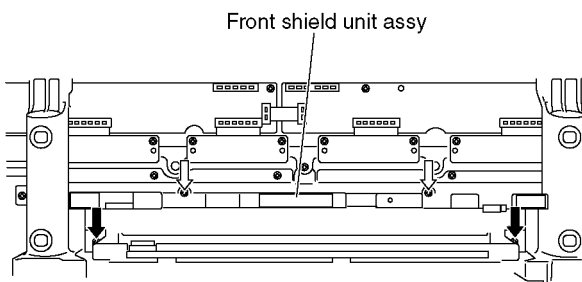

## 7.15. Remove the G-Board

1. Remove the Front shield unit assy. (See section 7.14.)
2. Remove the screws (×2 ⇨).
3. Remove the Front shield case front.

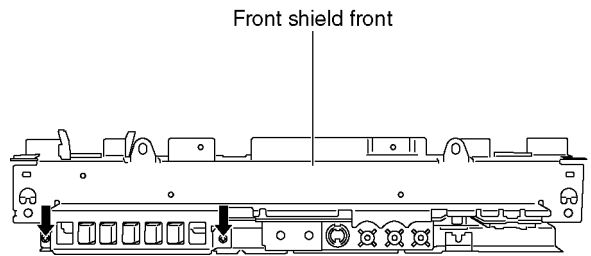

4. Disconnect the connectors (G51).
5. Remove the screws (×3 ⇨).
6. Remove the G-Board.

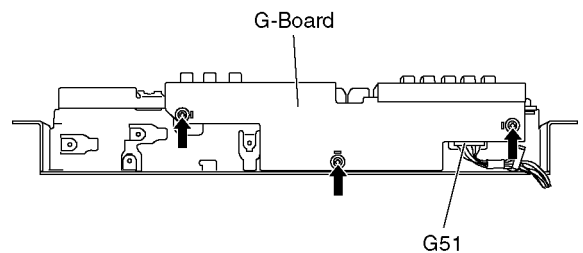

## 7.16. Remove the speaker L, R

1. Disconnect the connector (A12). (See section 7.4.)
2. Remove the screws (×4 ⇨ each) and remove the speaker L, R.

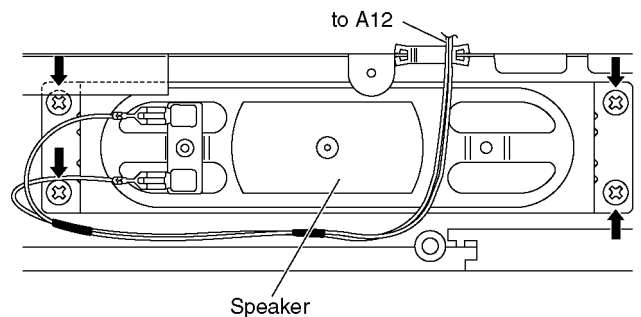

## 7.17. Remove the S-Board

1. Remove the stand brackets. (See section 7.10.)
2. Remove the screws (×2 ➡).
3. Disconnect the connector (S1).

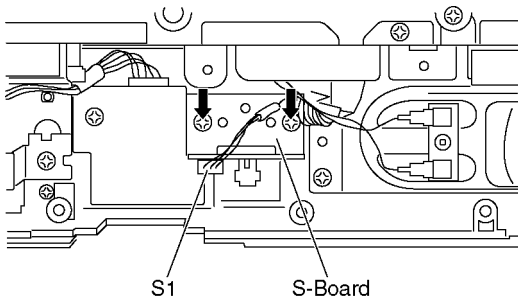

4. Remove the screws (×2 ➡) and remove the S-Board.

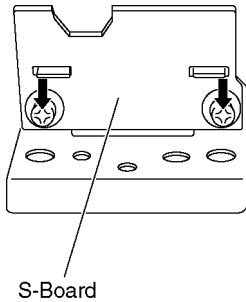

## 7.18. Remove the K-Board

1. Remove the S-Board. (See section 7.16.)
2. Unlock the cable clampers to free the cable.
3. Remove the screws (×2 ➡).
4. Disconnect the connectors (K1) and remove the K-Board.

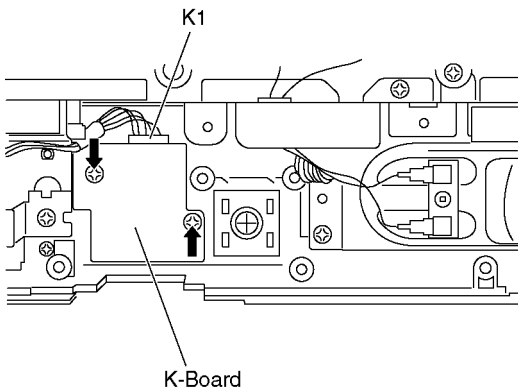

## 7.19. Remove the Plasma panel section from the Cabinet assy (glass)

1. Remove the stand brackets (left, right) fastening screw (×1 ➡ each).

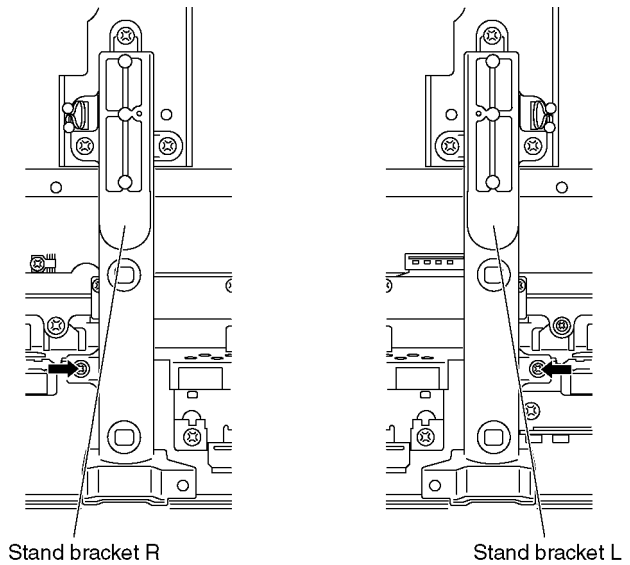

2. Remove the cabinet assy and the plasma panel fastening screws (×7 ➡).

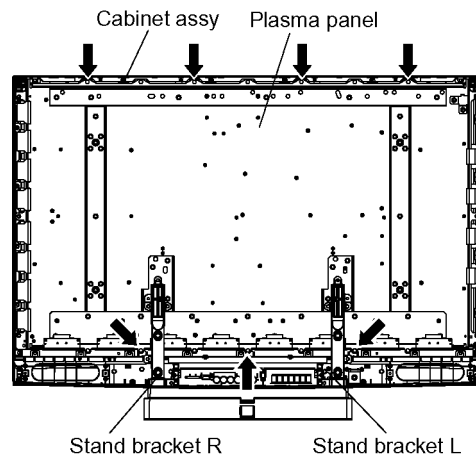

3. For leaving the plasma panel from the front frame, pull the bottom of the cabinet assy forward, lift, and remove.

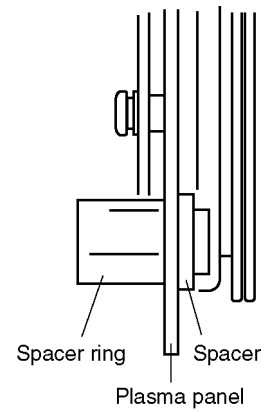
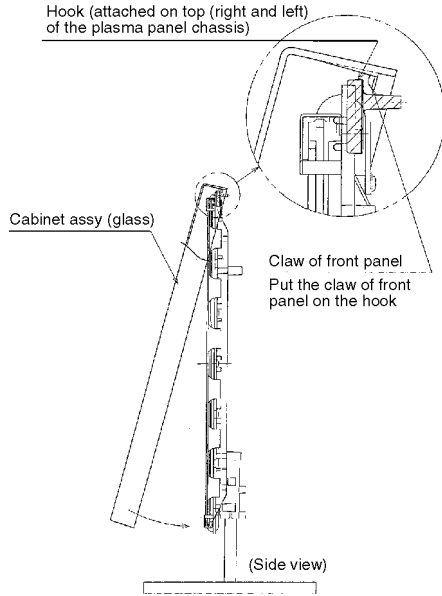

**Caution:**

- Please confirm the installation place of BC hook (L, R), Spacer and Spacer Ring when you exchange the Plasma Panel, and install BC hook (L, R), Spacer and Spacer Ring in an original installation place after exchanging the Plasma Panel.

**7.20. Replace the plasma panel (finished)**

4. Remove the spacers and spacer rings (x6 ➡).

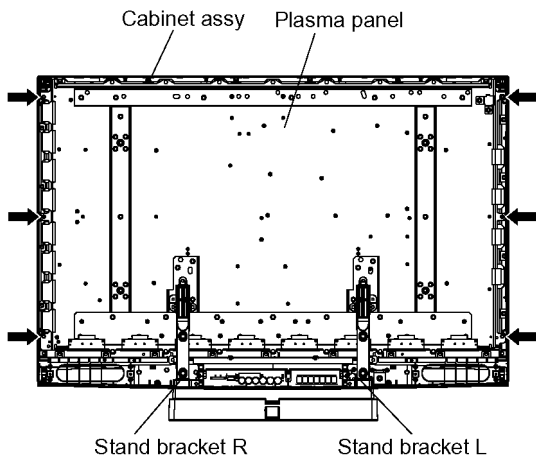

1. Place the new plasma panel (finished) on the flat surface of the table (covered by a soft cloth), with the plasma panel surface facing downward.
2. Attach the C1-Board and the C2-Board, connect the flexible cables (x16) from the Plasma panel to the C1-Board and the C2-Board, and fit the flexible cable holders.
3. Attach the Hooks (left, right) and fit the stand brackets (L, R) to the new plasma panel.
4. Place the plasma panel section on the servicing stand.
5. Attach the cabinet assy and each P.C.Board and so on, to the new plasma panel.

**\*When fitting the cabinet assy, be careful not to allow any debris, dust or handling residue to remain between the front glass and plasma panel.**

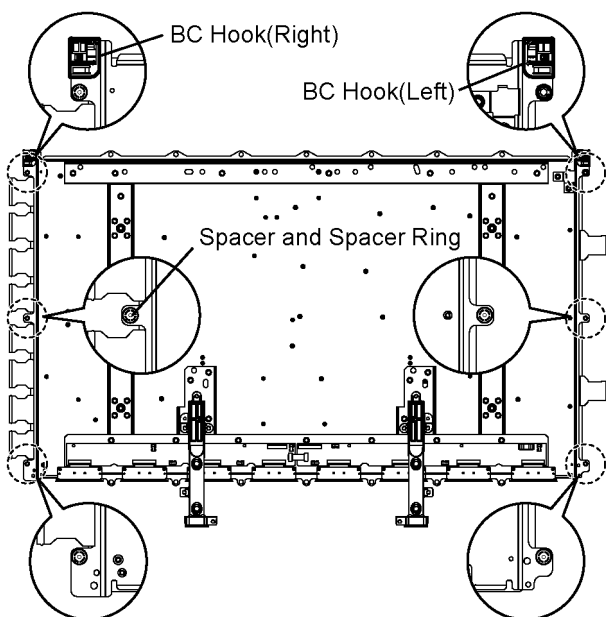

# 8 Measurements and Adjustments

## 8.1. Driver Set-up

### 8.1.1. Item / Preparation

1. Input a white signal to plasma video input.
2. Set the picture controls as follows.  
Picture menu: Dynamic  
PNR: OFF  
Aspect: 16:9

#### Caution

1. First perform Vsus adjustment.
2. Confirmation of Vscn voltage should be performed after confirmation of Vad adjustment.  
When Vad=-149V, Voltage of Vscn is -4V ±4V.

### 8.1.2. Adjustments

Adjust driver section voltages referring the panel data on the panel data label.

Check or adjust the following voltages with the multimeter.

Name	Test Point	Voltage	Volume	Remarks
Vsus	TPVSUS (SS)	Vsus ± 2V	R628 (P)	*
Ve	TPVE (SS)	Ve ± 1V	VR16000 (SS)	*
Vset	TPVSET (SC)	320V ± 7V	Fixed	
Vad	TPVAD (SC)	-149V ± 1V	VR16600 (SC)	
Vscn	TPVSCN (SC)	Vad+145V ± 4V	Fixed	
Vda	TPVDA (SS)	75V ± 1V, -2V	Fixed	

\*See the Panel label.

Panel Label information

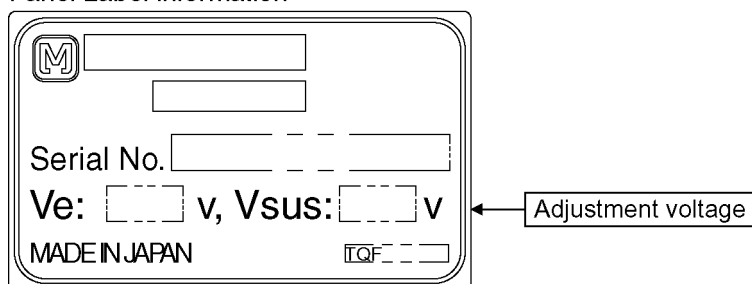

### 8.1.3. P.C.B. (Printed Circuit Board) exchange

#### 8.1.3.1. Caution

1. To remove P.C.B. , wait 1 minute after power was off for discharge from electrolysis capacitors.

#### 8.1.3.2. Quick adjustment after P.C.B. exchange

Adjust the following voltages with the multimeter.

P.C.B.	Name	Test Point	Voltage	Volume	Remarks
P Board	Vsus	TPVSUS (SS)	Vsus ± 2V	R628 (P)	*
SC Board	Vad	TPVAD (SC)	-105V ± 1V	VR16600 (SC)	
SS Board	Ve	TPVE (SS)	Ve ± 1V	VR16000 (SS)	*

\*See the Panel label.

#### Caution:

Absolutely do not reduce Vsus below Ve not to damage the P.C.B.

### 8.1.4. Adjustment Volume Location

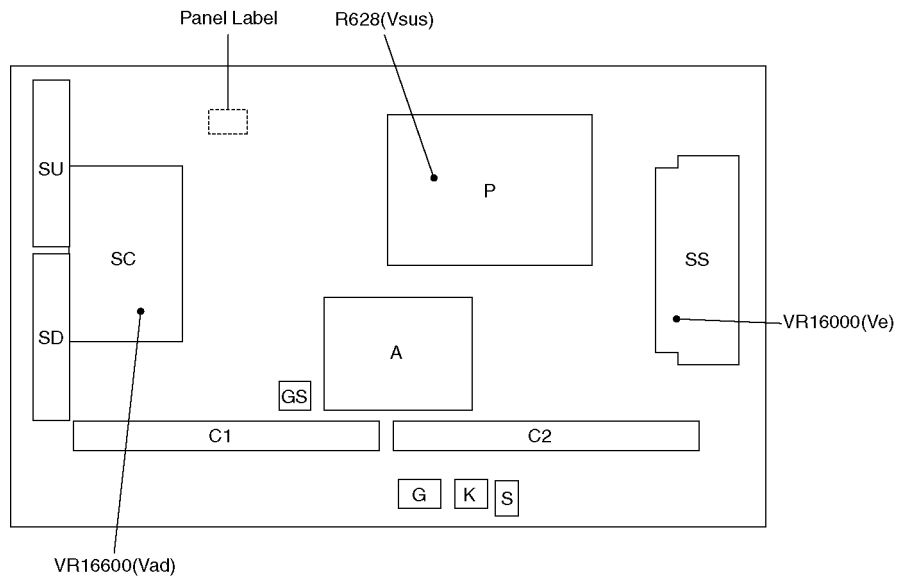

### 8.1.5. Test Point Location

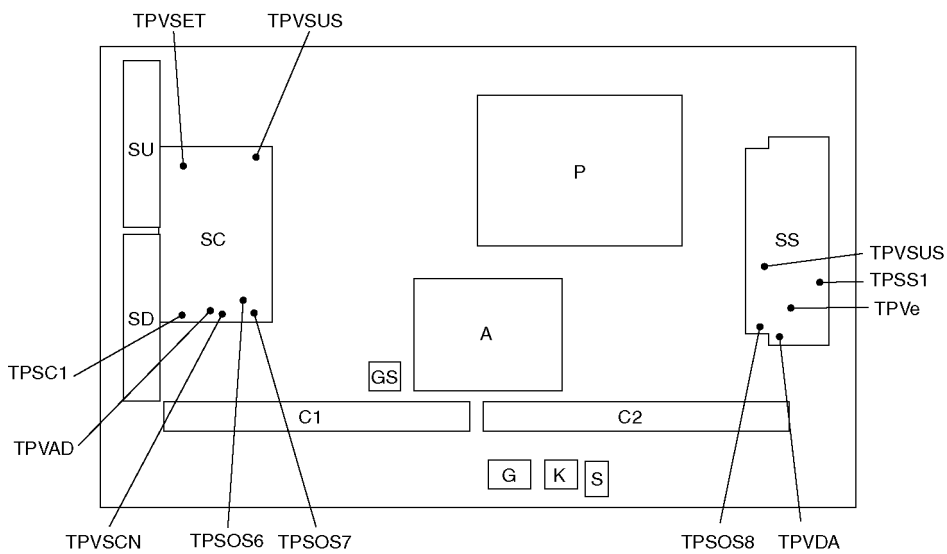



# 9 Block Diagram

## 9.1. Block Diagram (1/5)

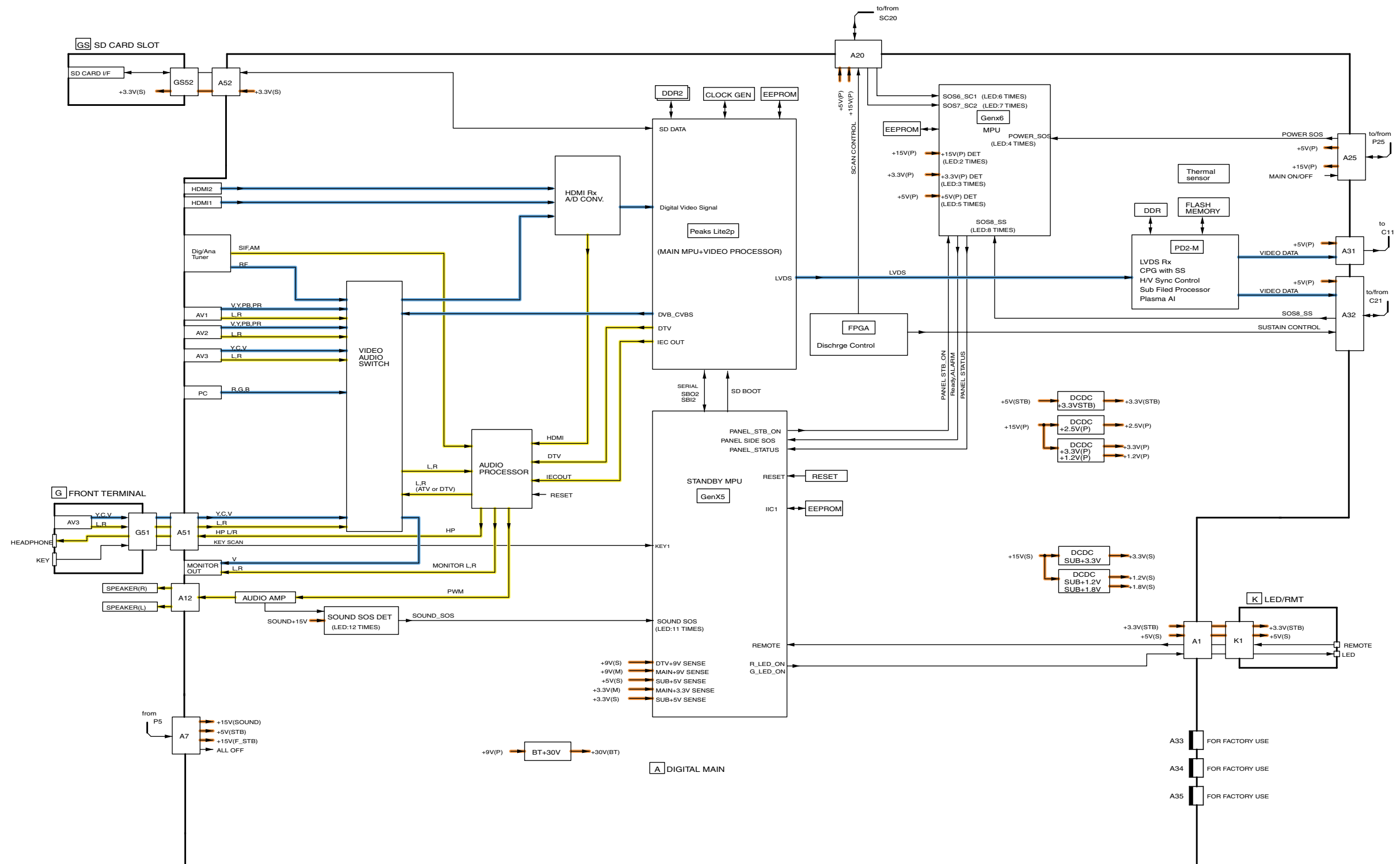

TH-42PV8D/H/HM/M/MR/MS/MT  
Block (1/5) Diagram

TH-42PV8D/H/HM/M/MR/MS/MT  
Block (1/5) Diagram

## 9.2. Block Diagram (2/5)

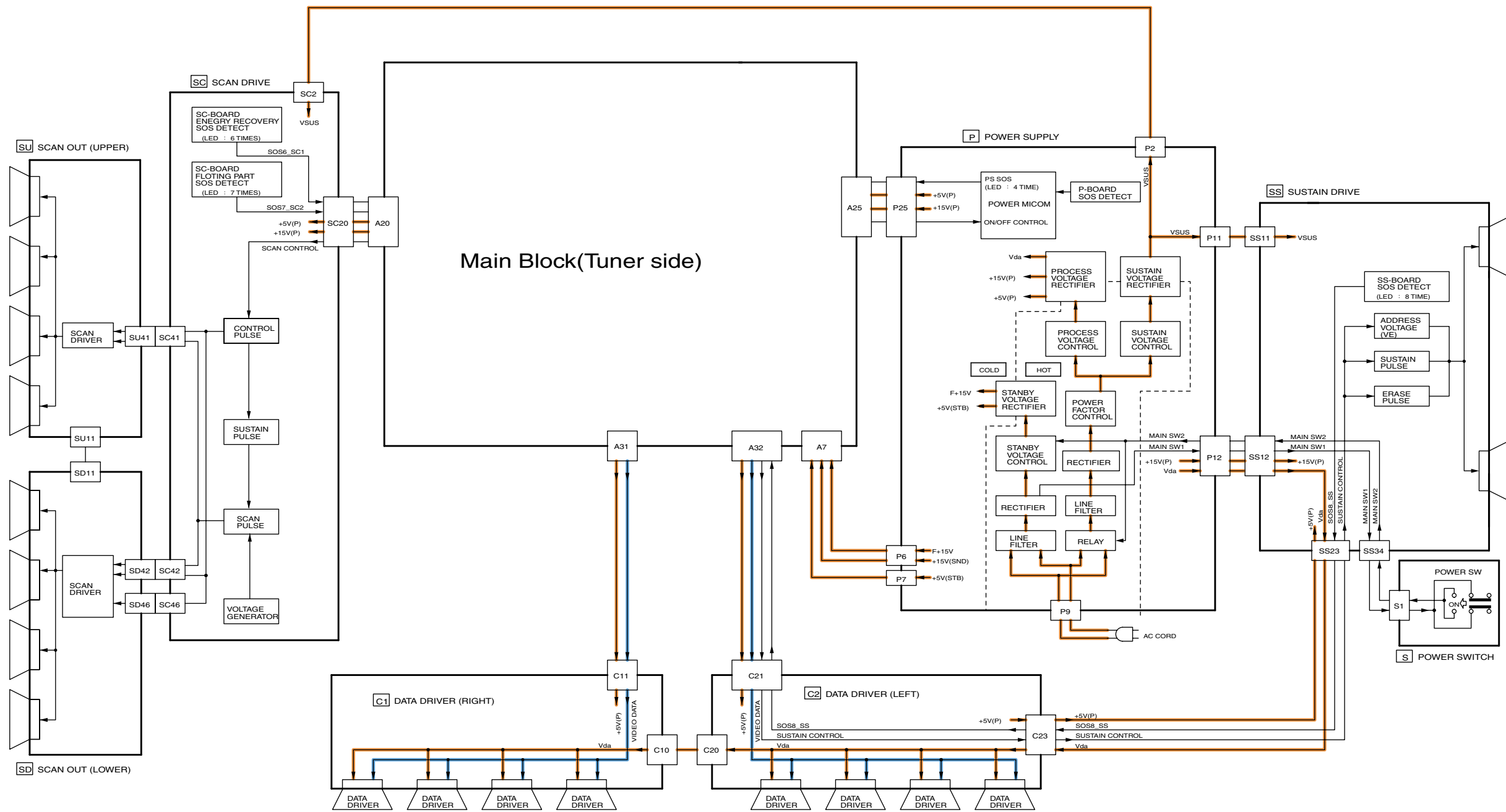

TH-42PV8D/H/HM/M/MR/MS/MT  
Block (2/5) Diagram

TH-42PV8D/H/HM/M/MR/MS/MT  
Block (2/5) Diagram



### 9.3. Block Diagram (3/5)

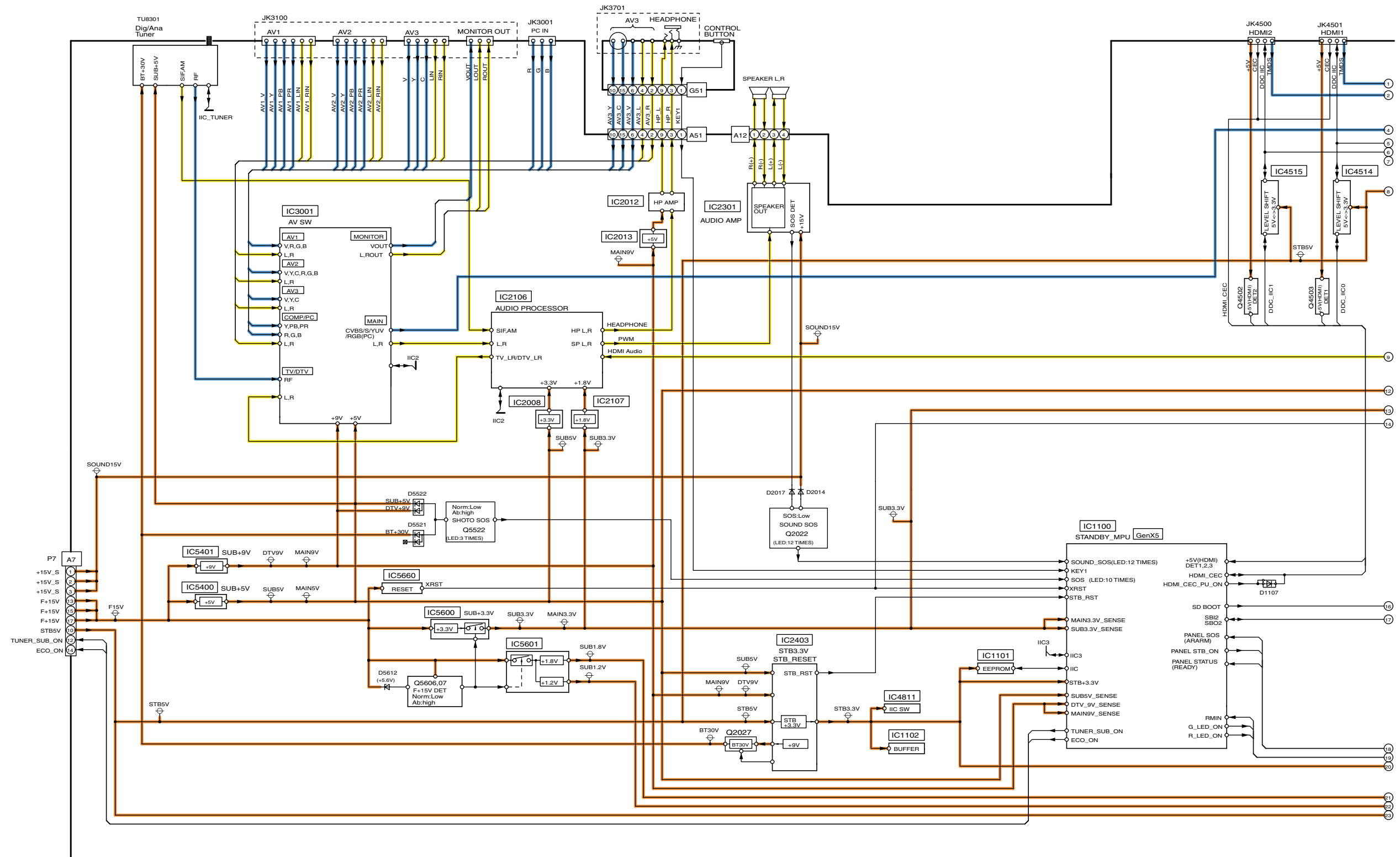

TH-42PV8D/H/HM/M/MR/MS/MT  
Block (3/5) Diagram

TH-42PV8D/H/HM/M/MR/MS/MT  
Block (3/5) Diagram

### 9.4. Block Diagram (4/5)

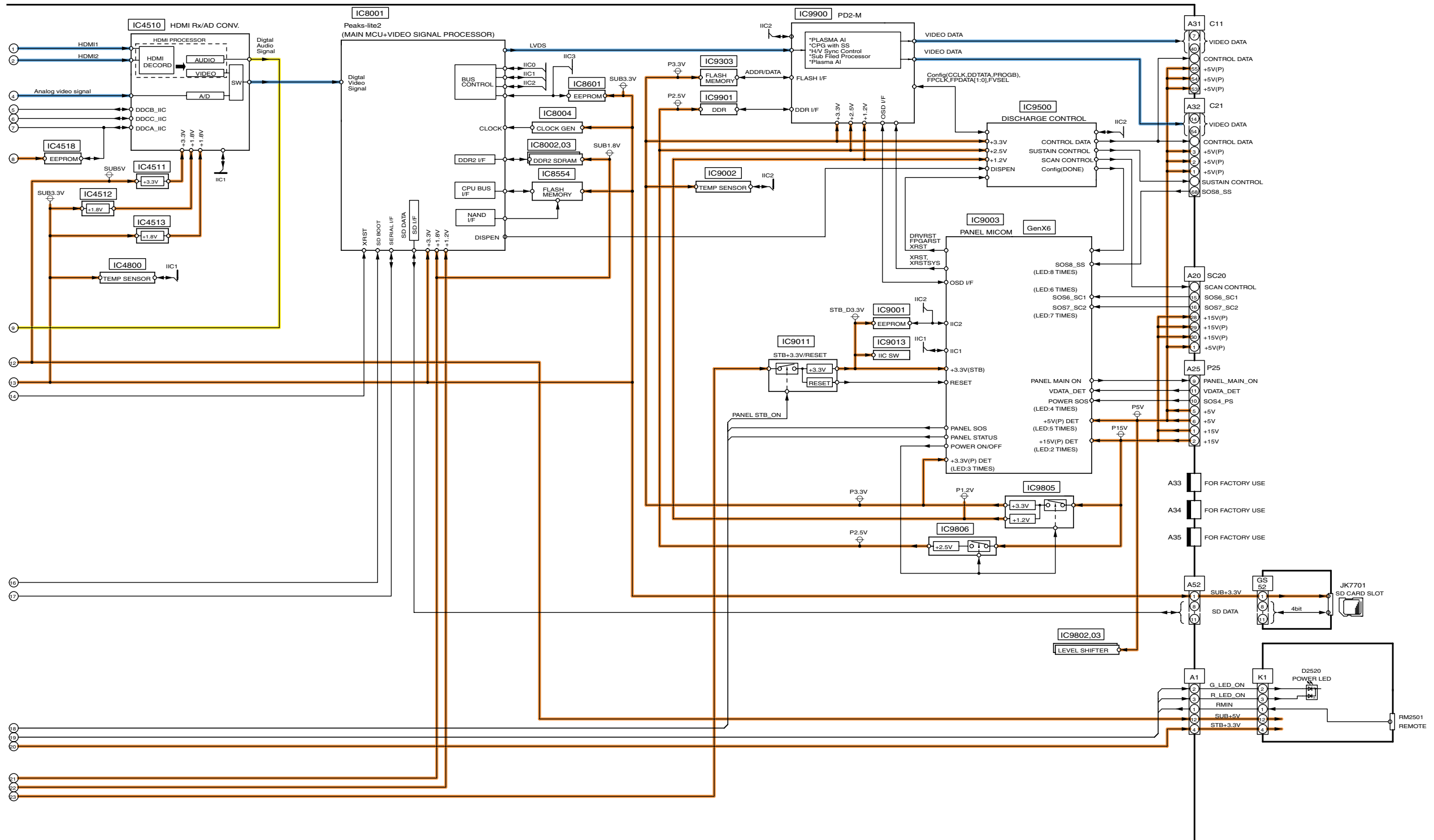

TH-42PV8D/H/HM/M/MR/MS/MT  
Block (4/5) Diagram

TH-42PV8D/H/HM/M/MR/MS/MT  
Block (4/5) Diagram

## 9.5. Block Diagram (5/5)

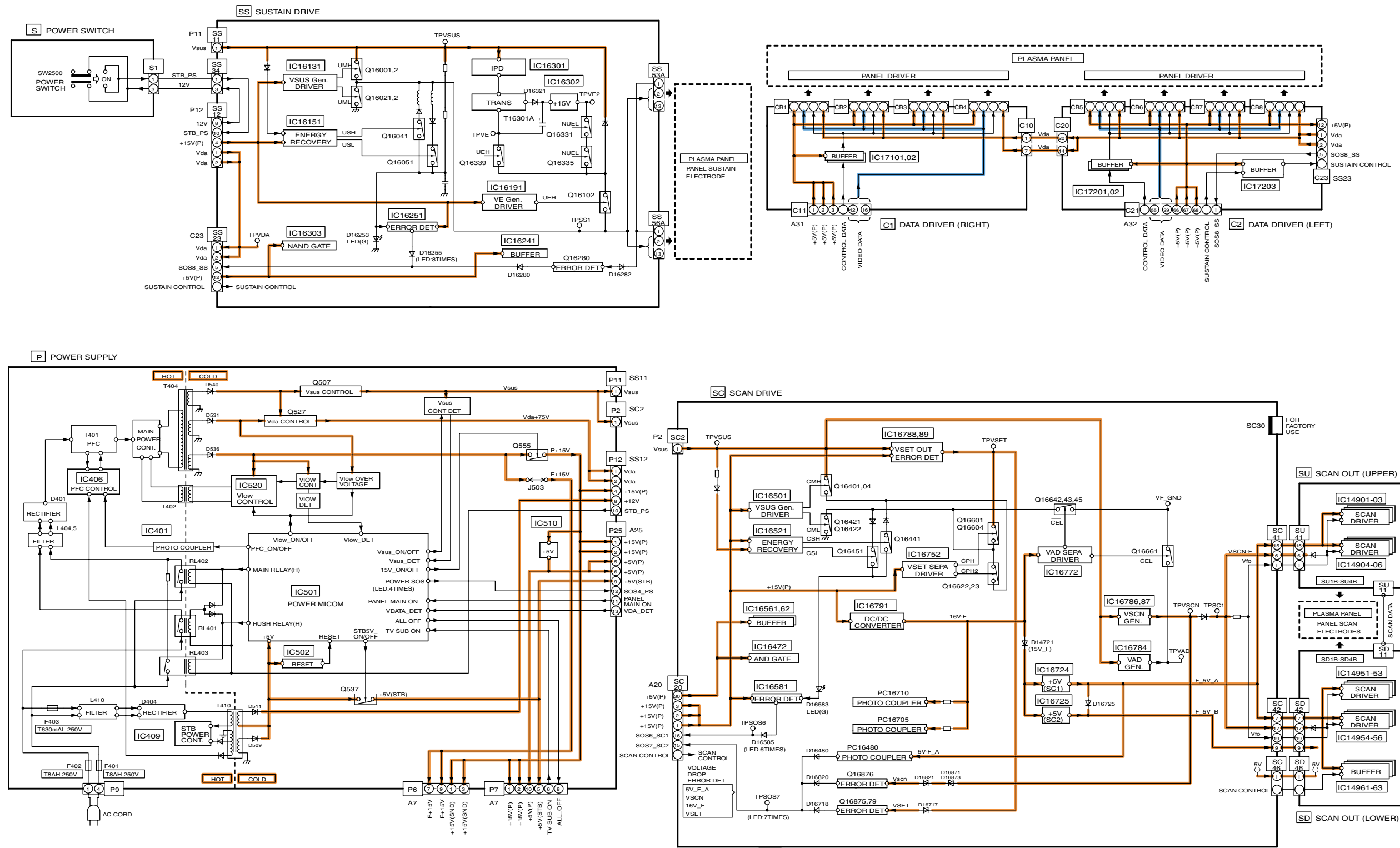

TH-42PV8D/H/HM/M/MR/MS/MT  
Block (5/5) Diagram

TH-42PV8D/H/HM/M/MR/MS/MT  
Block (5/5) Diagram



# 10 Wiring Connection Diagram

## 10.1. Caution statement.

**Caution:**

Please confirm that all flexible cables are assembled correctly.  
 Also make sure that they are locked in the connectors.  
 Verify by giving the flexible cables a very slight pull.

## 10.2. Wiring

The diagram below shows the overall wire dressing for the assembly.

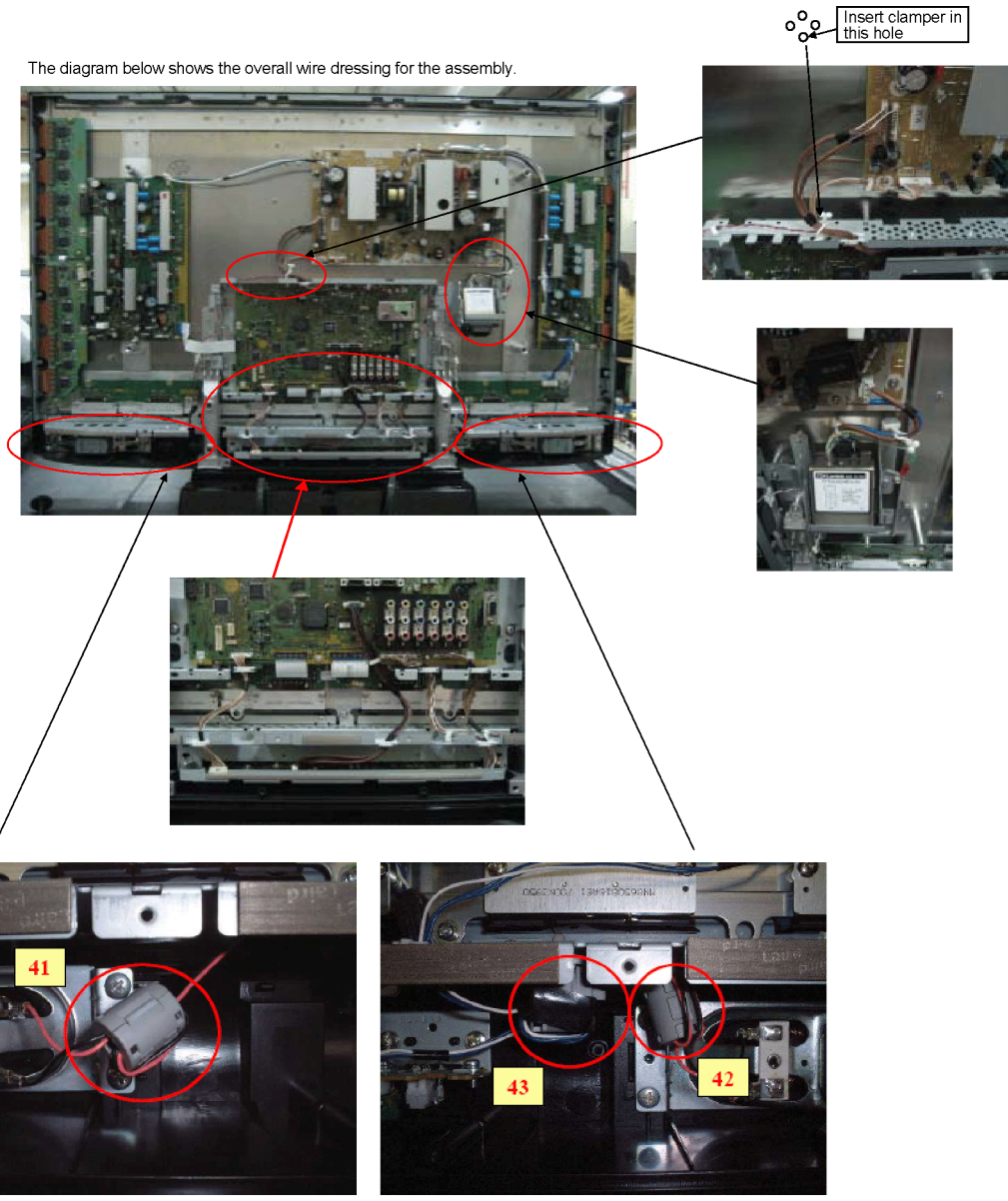

Position	Parts No.	Q'TY	Remark
41 (A12-R speaker)	J0KG00000011	1	3 turns
42 (A12-L speaker)	J0KG00000011	1	3 turns
43 (SS34-S1)	J0KG00000042	1	3 turns





# 11.2. P-Board (1/6) Schematic Diagram

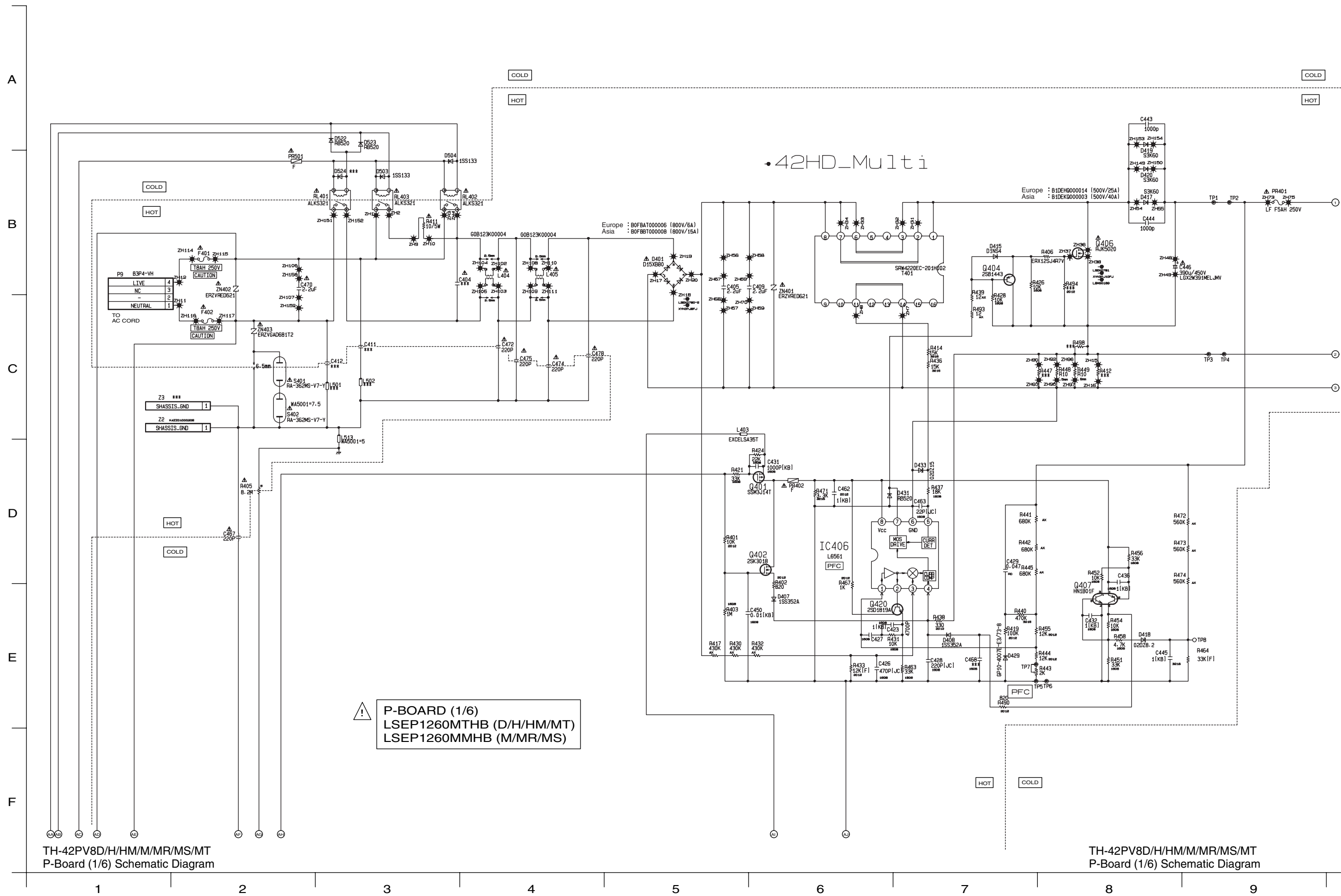





# 11.4. P-Board (3/6) Schematic Diagram

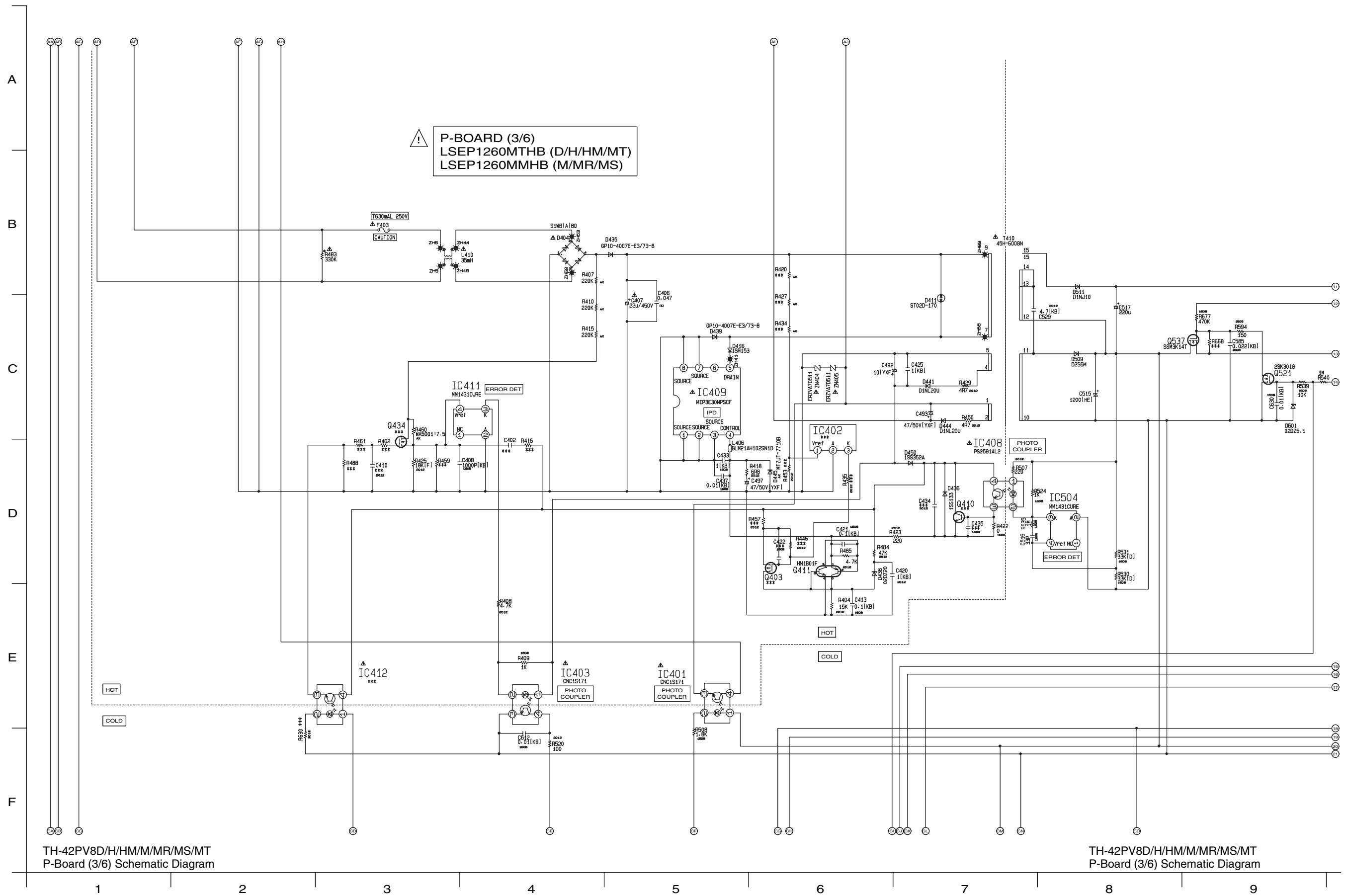

# 11.5. P-Board (4/6) Schematic Diagram

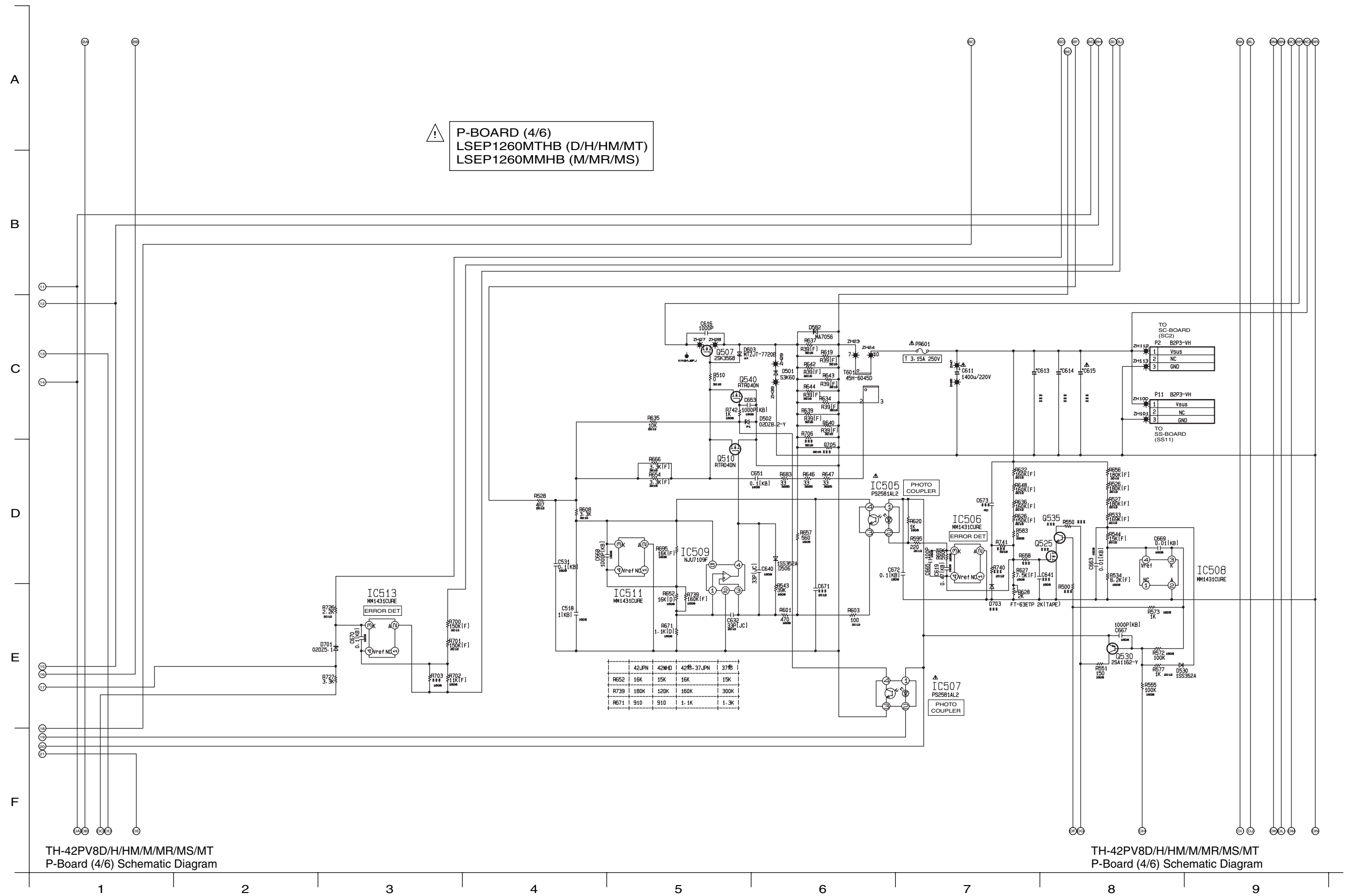

TH-42PV8D/H/HM/M/MR/MS/MT  
P-Board (4/6) Schematic Diagram

TH-42PV8D/H/HM/M/MR/MS/MT  
P-Board (4/6) Schematic Diagram



# 11.7. P-Board (6/6) Schematic Diagram

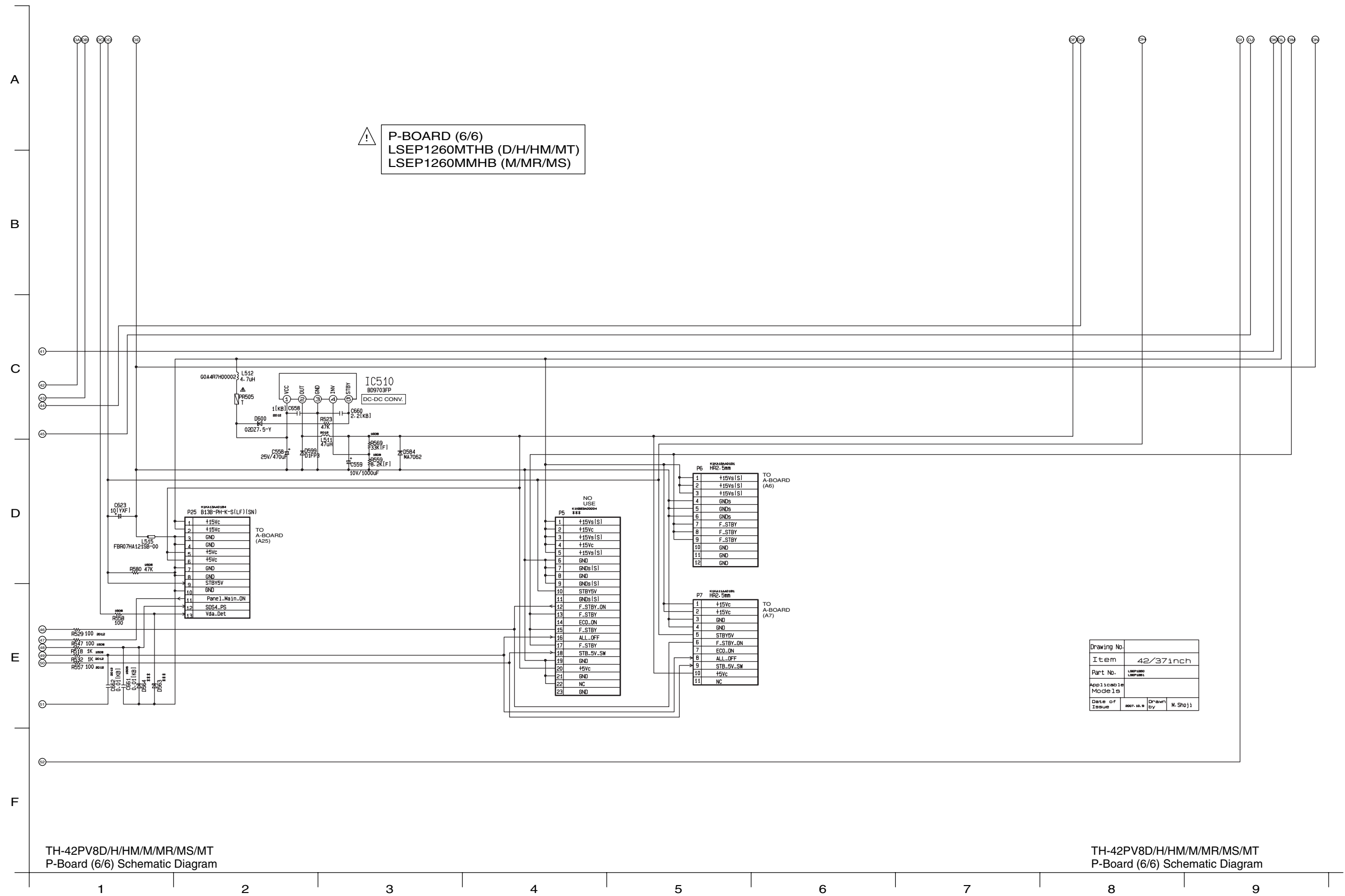

⚠ P-BOARD (6/6)  
LSEP1260MTHB (D/H/HM/MT)  
LSEP1260MMHB (M/MR/MS)

Drawing No.	
Item	42/37inch
Part No.	LSEP1260MTHB
Applicable Models	
Date of Issue	2007.10.9
Drawn by	M.Shoji

TH-42PV8D/H/HM/M/MR/MS/MT  
P-Board (6/6) Schematic Diagram

TH-42PV8D/H/HM/M/MR/MS/MT  
P-Board (6/6) Schematic Diagram

# 11.8. G, GS, and K-Board Schematic Diagram

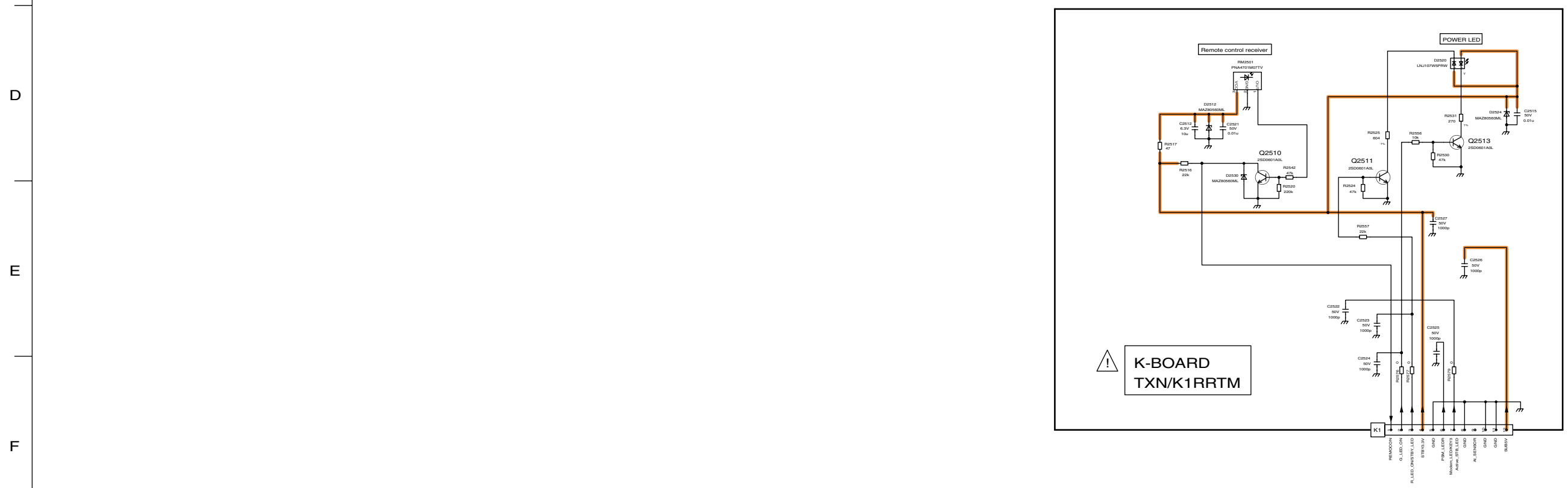
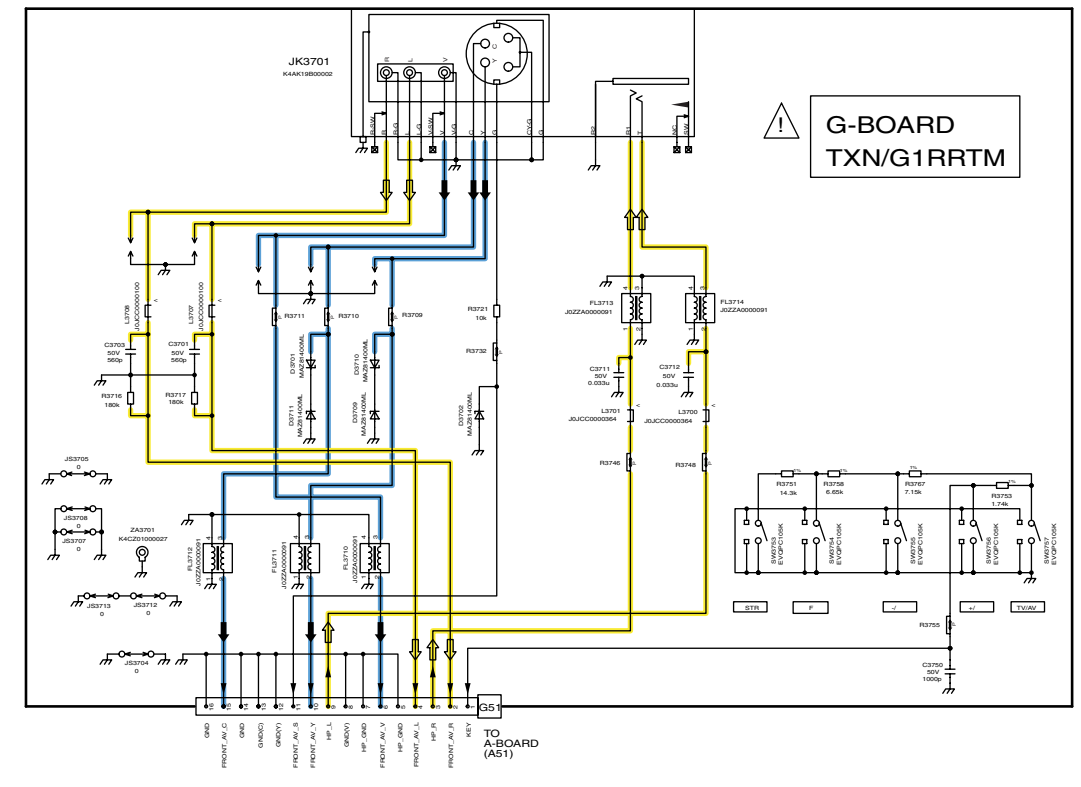
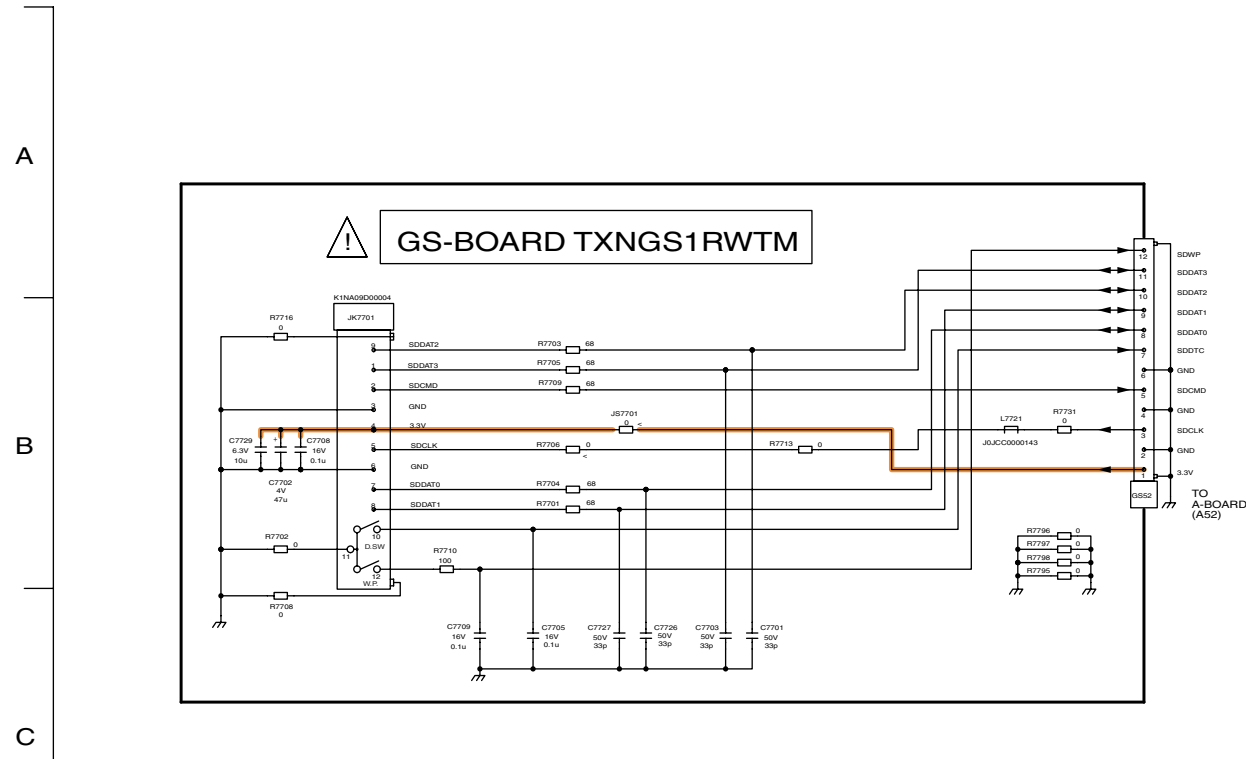

TH-42PV8D/H/HM/M/MR/MS/MT  
G,GS, and K-Board Schematic Diagram

TH-42PV8D/H/HM/M/MR/MS/MT  
G,GS, and K-Board Schematic Diagram

1 2 3 4 5 6 7 8 9

# 11.9. A-Board (1/19) Schematic Diagram

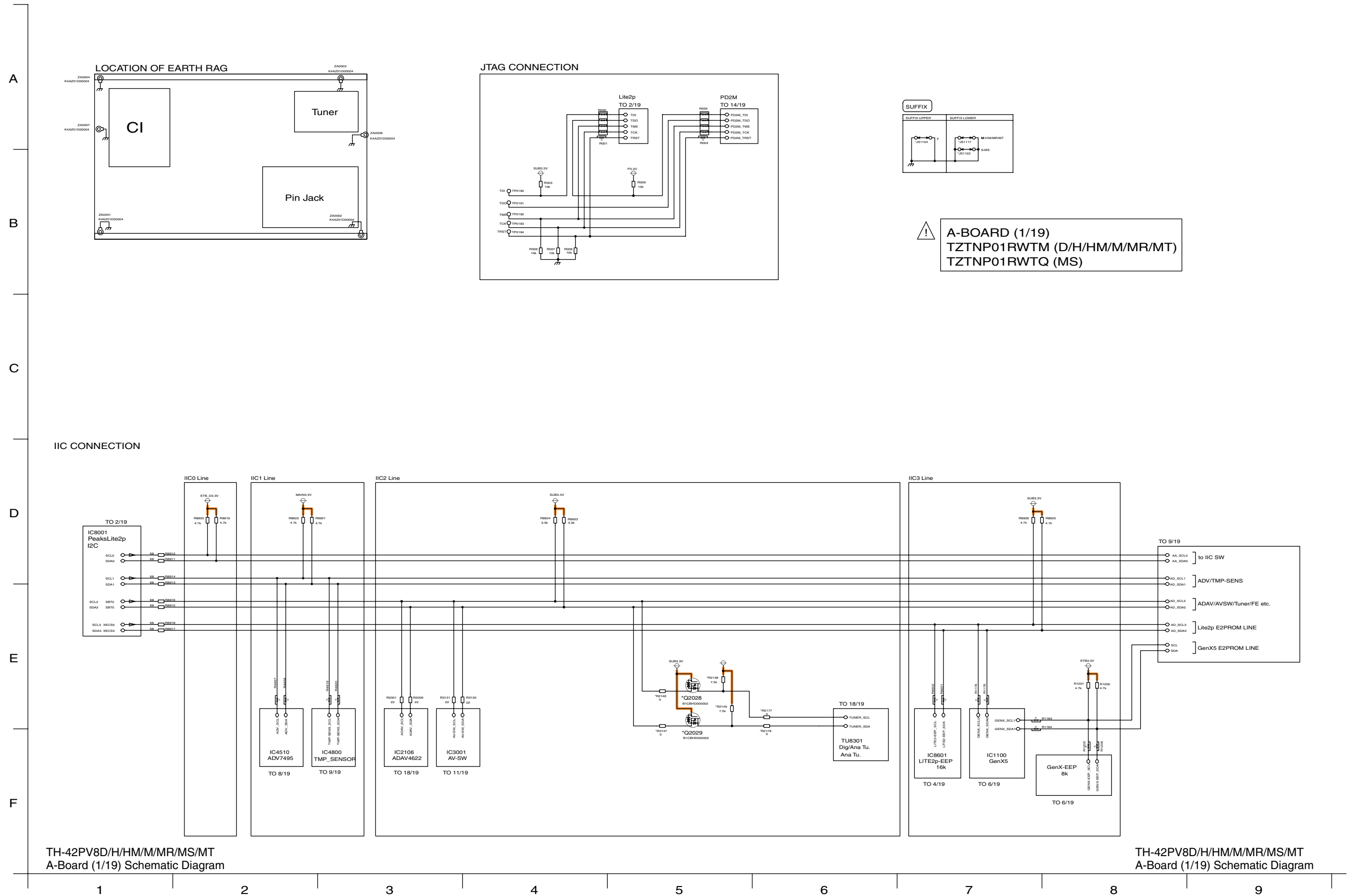



# 11.10. A-Board (2/19) Schematic Diagram

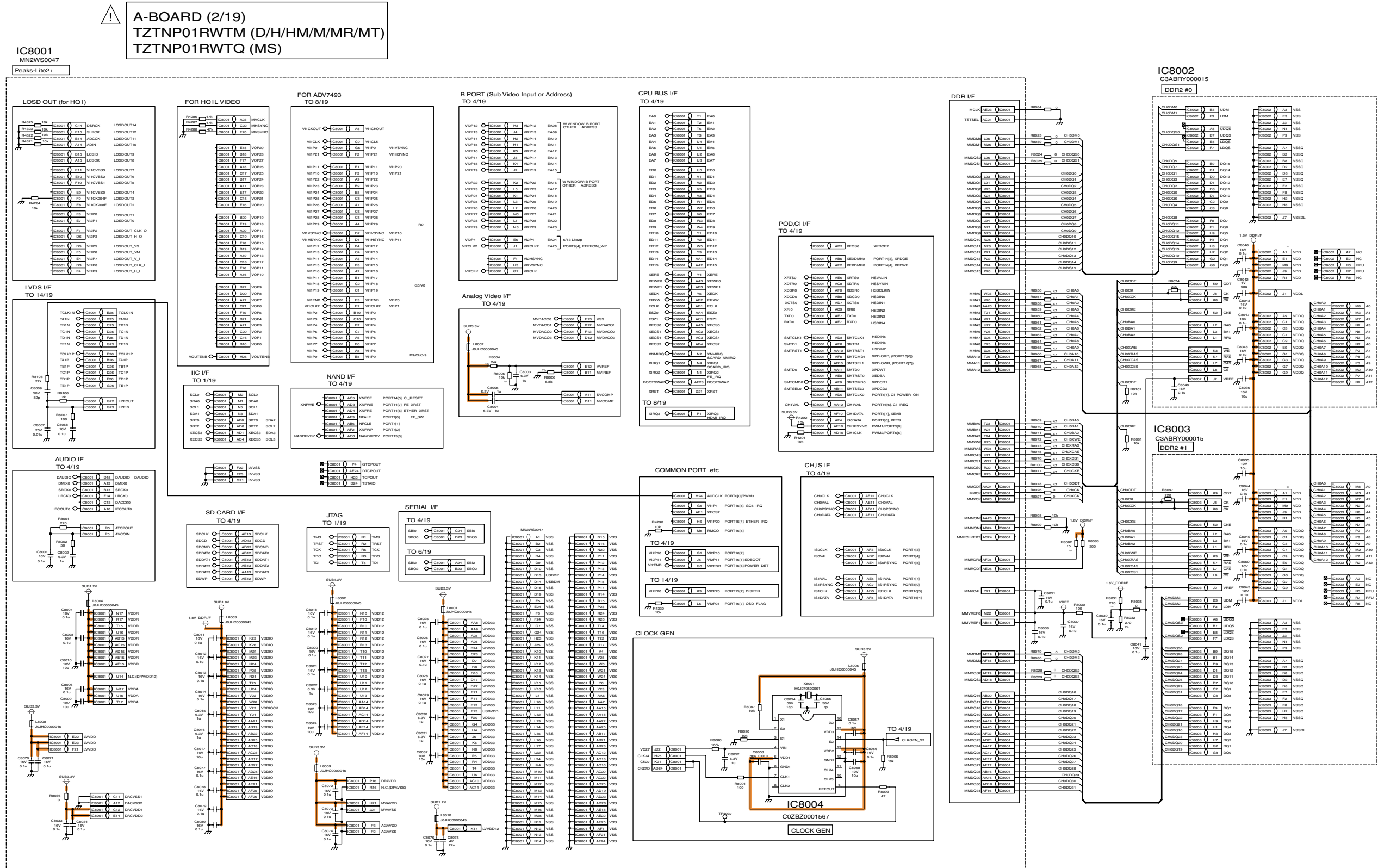

TH-42PV8D/H/HM/MR/MS/MT  
 A-Board (2/19) Schematic Diagram

TH-42PV8D/H/HM/MR/MS/MT  
 A-Board (2/19) Schematic Diagram



# 11.11. A-Board (3/19) Schematic Diagram

⚠ A-BOARD (3/19)  
 TZTNP01RWTM (D/H/HM/M/MR/MT)  
 TZTNP01RWTQ (MS)

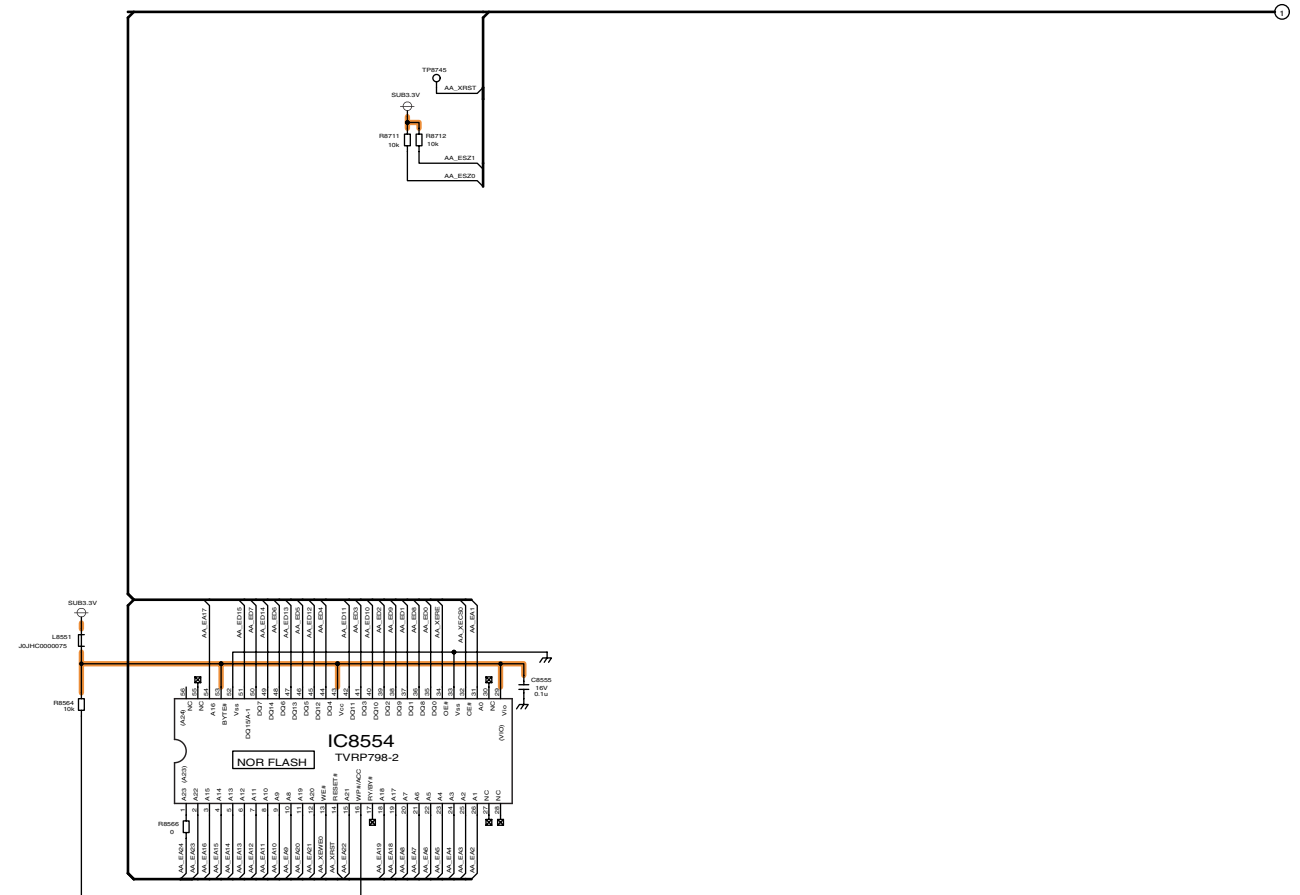

# 11.12. A-Board (4/19) Schematic Diagram

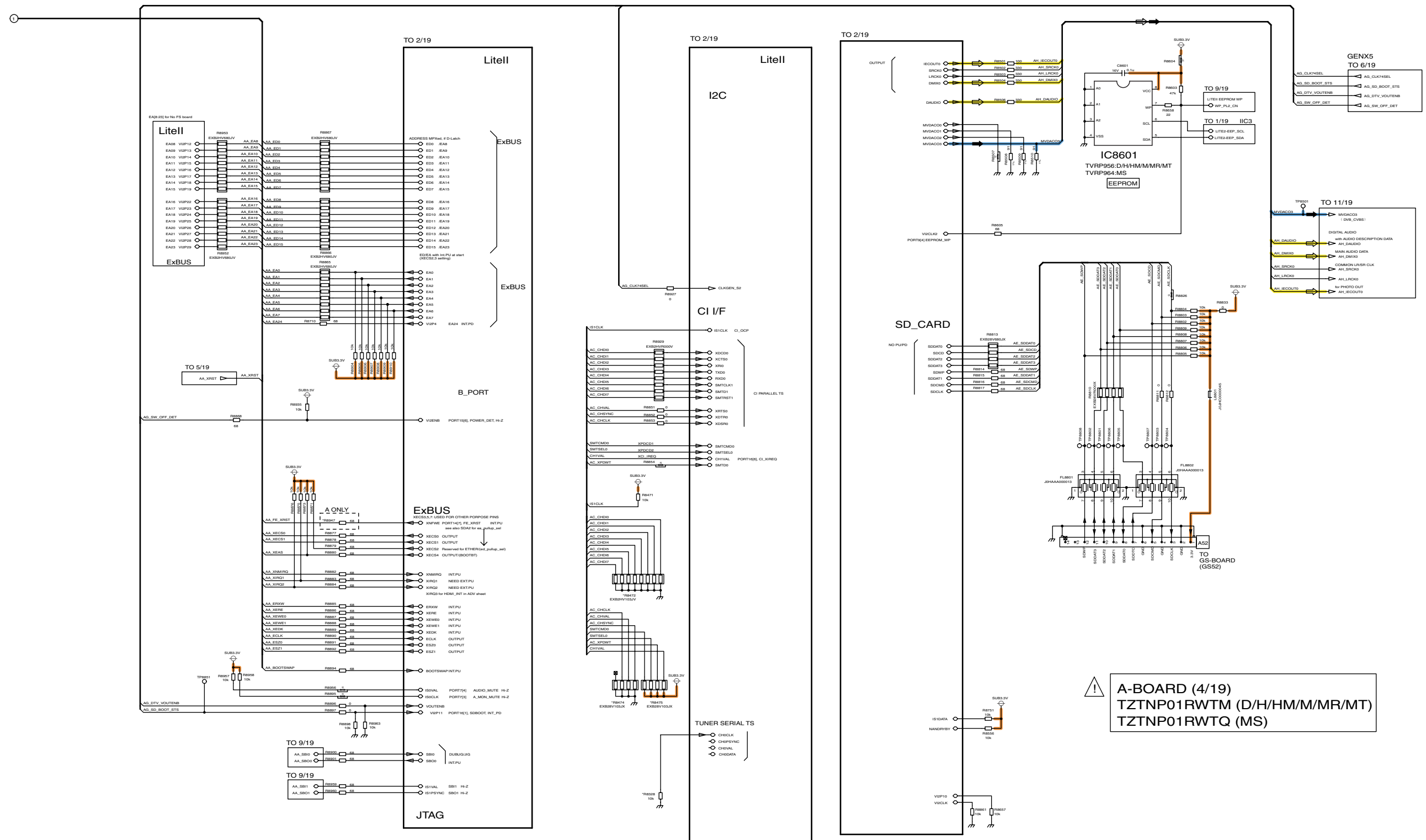

TH-42PV8D/H/HM/MR/MS/MT  
A-Board (4/19) Schematic Diagram

TH-42PV8D/H/HM/MR/MS/MT  
A-Board (4/19) Schematic Diagram

# 11.13. A-Board (5/19) Schematic Diagram

⚠ A-BOARD (5/19)  
TZTNP01RWTM (D/H/HM/M/MR/MT)  
TZTNP01RWTQ (MS)

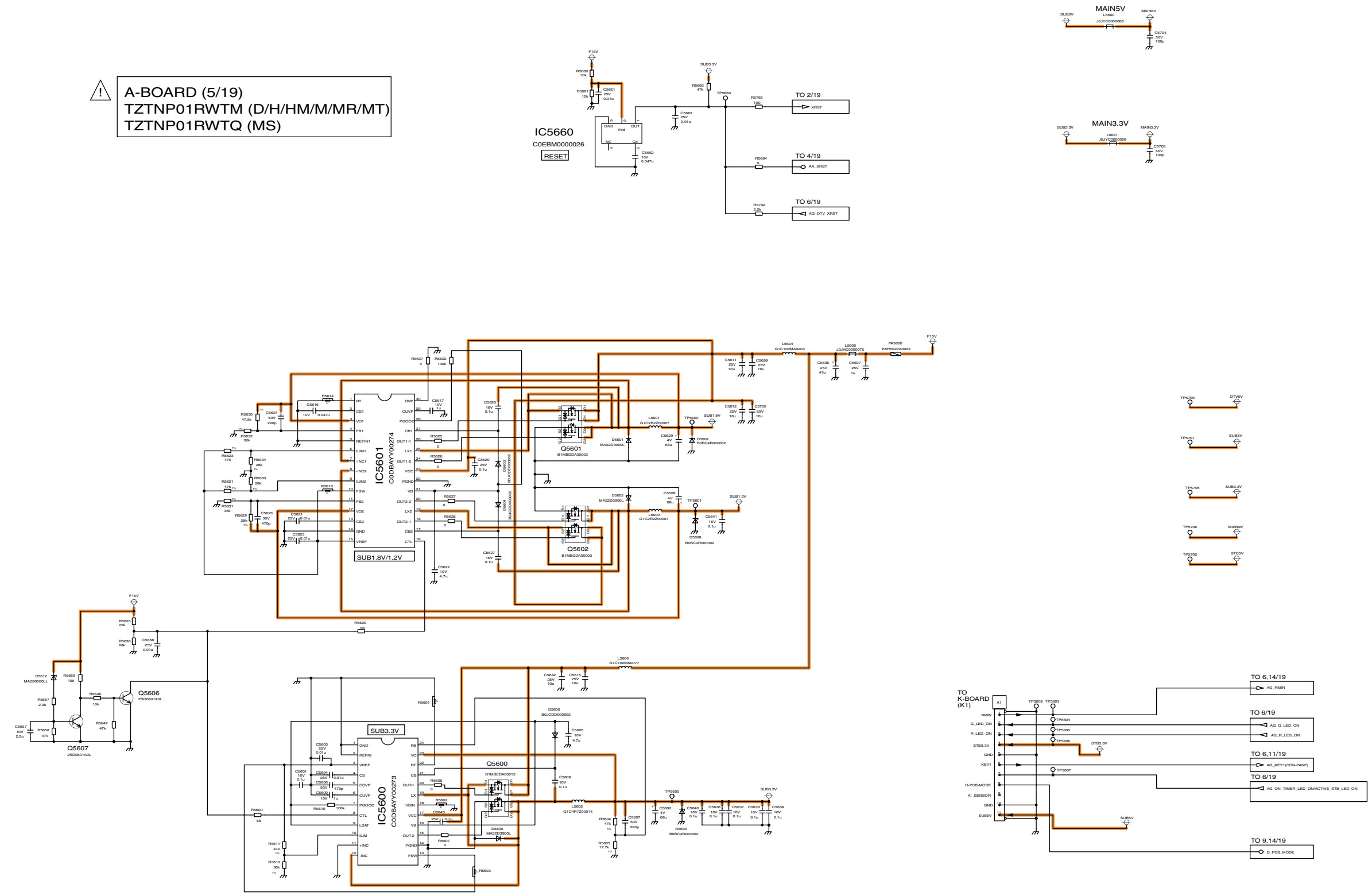

TH-42PV8D/H/HM/M/MR/MS/MT  
A-Board (5/19) Schematic Diagram

TH-42PV8D/H/HM/M/MR/MS/MT  
A-Board (5/19) Schematic Diagram

37

38

39

40

41

42

43

44

45



# 11.15. A-Board (7/19) Schematic Diagram

! A-BOARD (7/19)  
TZTNP01RWTM (D/H/HM/M/MR/MT)  
TZTNP01RWTQ (MS)

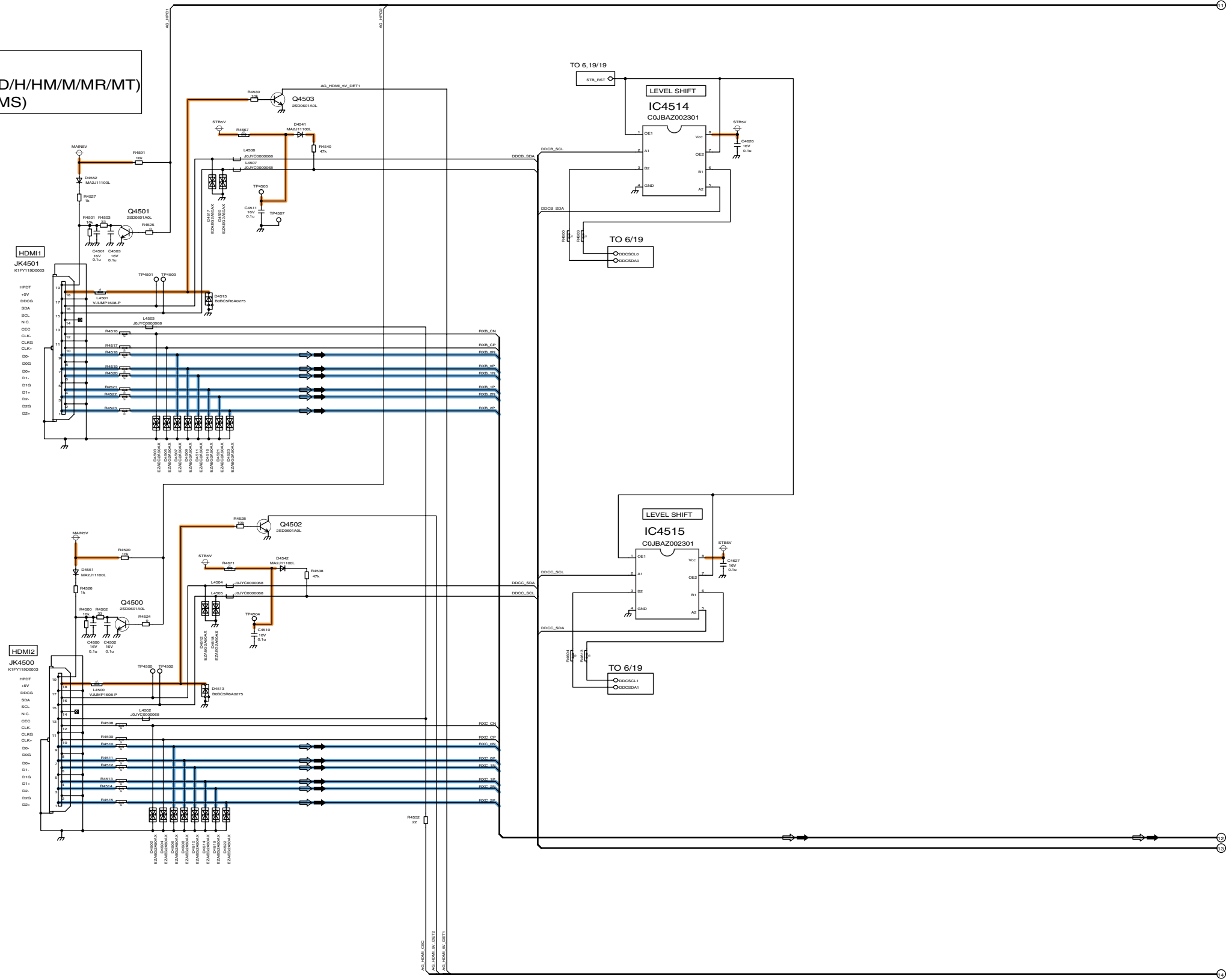

TH-42PV8D/H/HM/M/MR/MS/MT  
A-Board (7/19) Schematic Diagram

TH-42PV8D/H/HM/M/MR/MS/MT  
A-Board (7/19) Schematic Diagram

55

56

57

58

59

60

61

62

63

# 11.16. A-Board (8/19) Schematic Diagram

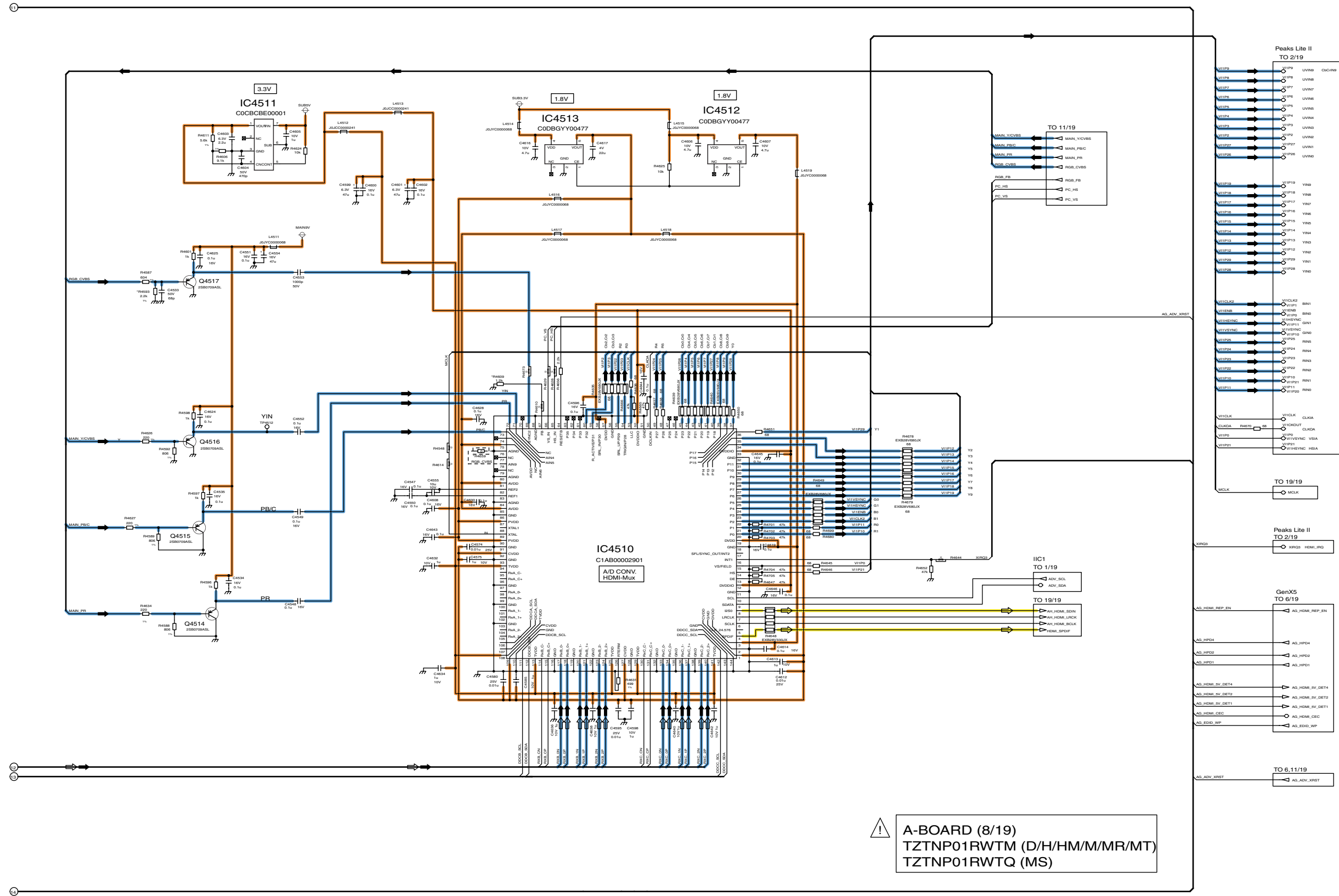

⚠ A-BOARD (8/19)  
TZTNP01RWTM (D/H/HM/M/MR/MT)  
TZTNP01RWTQ (MS)

TH-42PV8D/H/HM/M/MR/MS/MT  
A-Board (8/19) Schematic Diagram

TH-42PV8D/H/HM/M/MR/MS/MT  
A-Board (8/19) Schematic Diagram

# 11.17. A-Board (9/19) Schematic Diagram

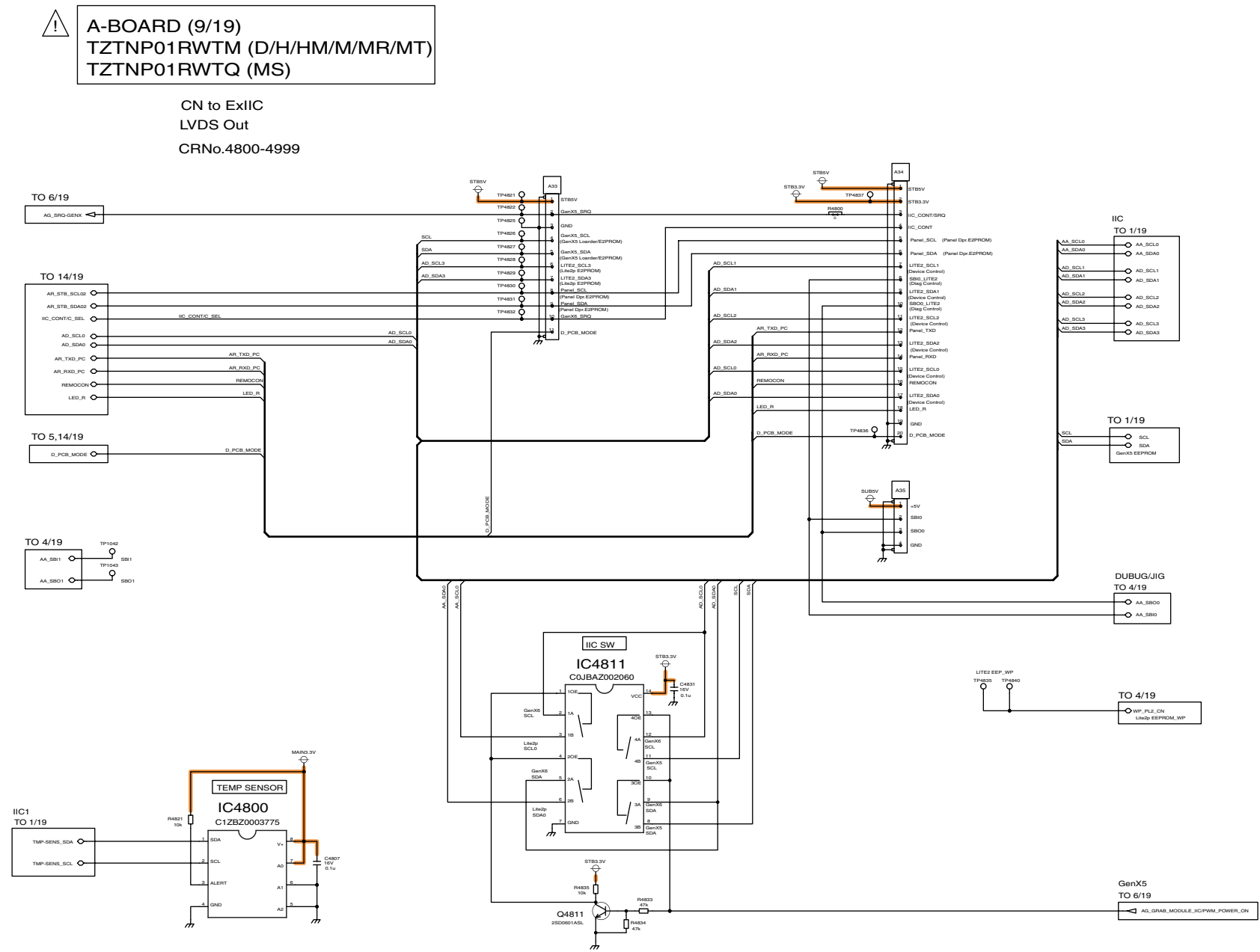

# 11.18. A-Board (10/19) Schematic Diagram

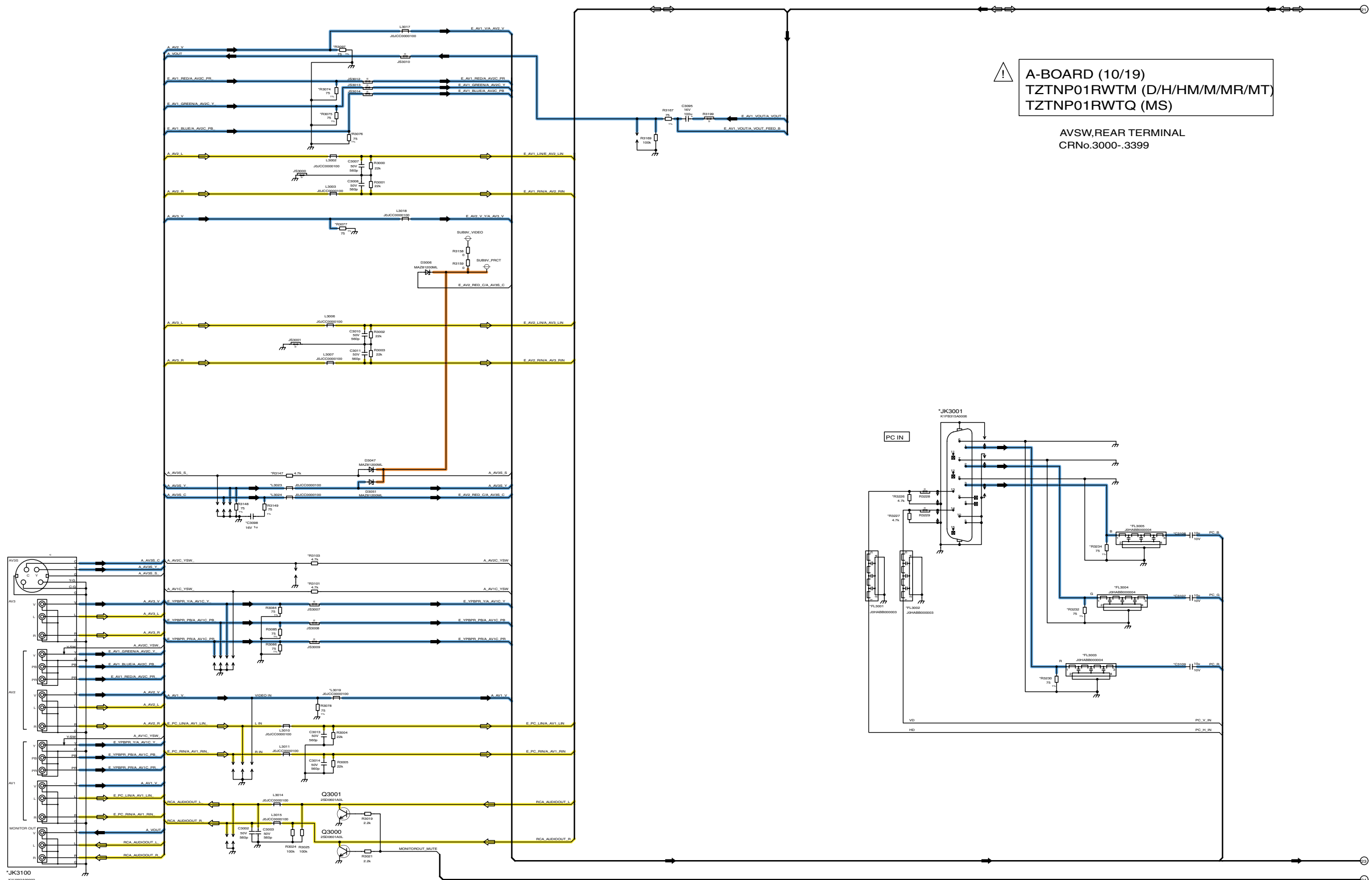

⚠ A-BOARD (10/19)  
 TZTNP01RWTM (D/H/HM/M/MR/MT)  
 TZTNP01RWTQ (MS)  
 AVSW, REAR TERMINAL  
 CRNo.3000-.3399

JK3100  
 TH-42PV8D/H/HM/M/MR/MS/MT  
 A-Board (10/19) Schematic Diagram

JK3001  
 TH-42PV8D/H/HM/M/MR/MS/MT  
 A-Board (10/19) Schematic Diagram

82

83

84

85

86

87

88

89

90





# 11.20. A-Board (12/19) Schematic Diagram

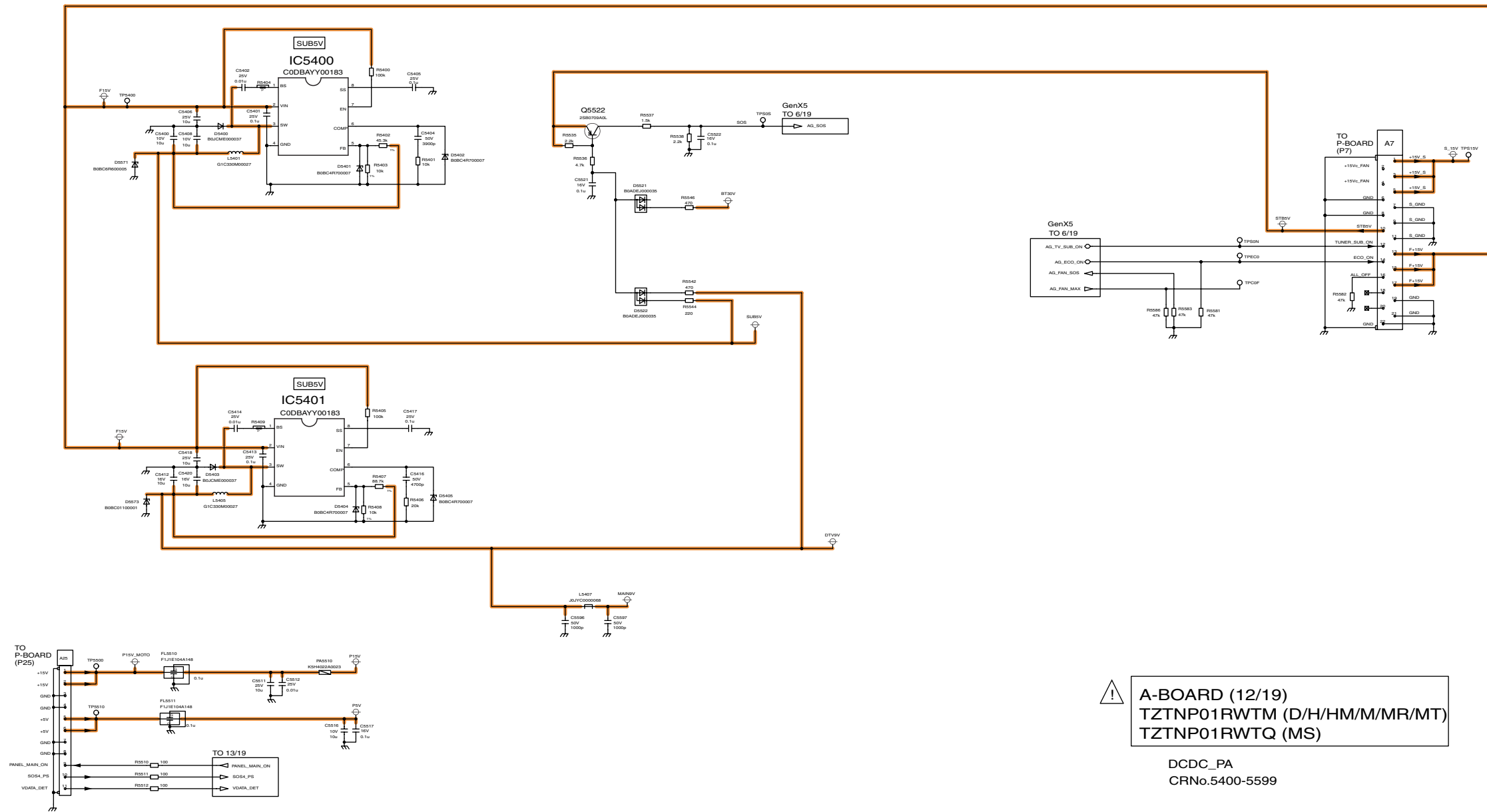

⚠ A-BOARD (12/19)  
 TZTNP01RWTM (D/H/HM/M/MR/MT)  
 TZTNP01RWTQ (MS)

DCDC\_PA  
 CRNo.5400-5599

# 11.21. A-Board (13/19) Schematic Diagram

⚠ A-BOARD (13/19)  
TZTNP01RWTM (D/H/HM/M/MR/MT)  
TZTNP01RWTQ (MS)

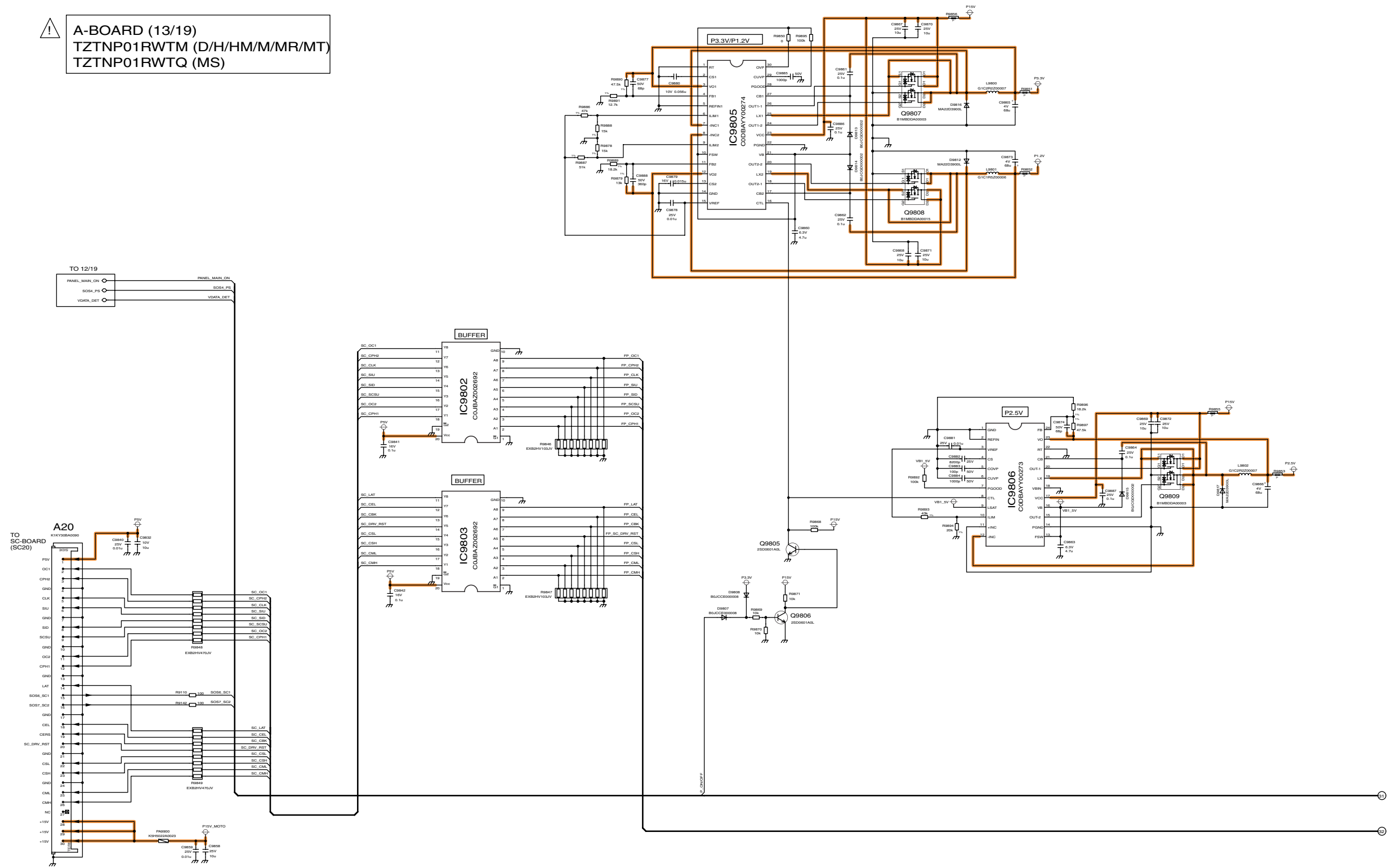

TH-42PV8D/H/HM/M/MR/MS/MT  
A-Board (13/19) Schematic Diagram

TH-42PV8D/H/HM/M/MR/MS/MT  
A-Board (13/19) Schematic Diagram

109

110

111

112

113

114

115

116

117

# 11.22. A-Board (14/19) Schematic Diagram

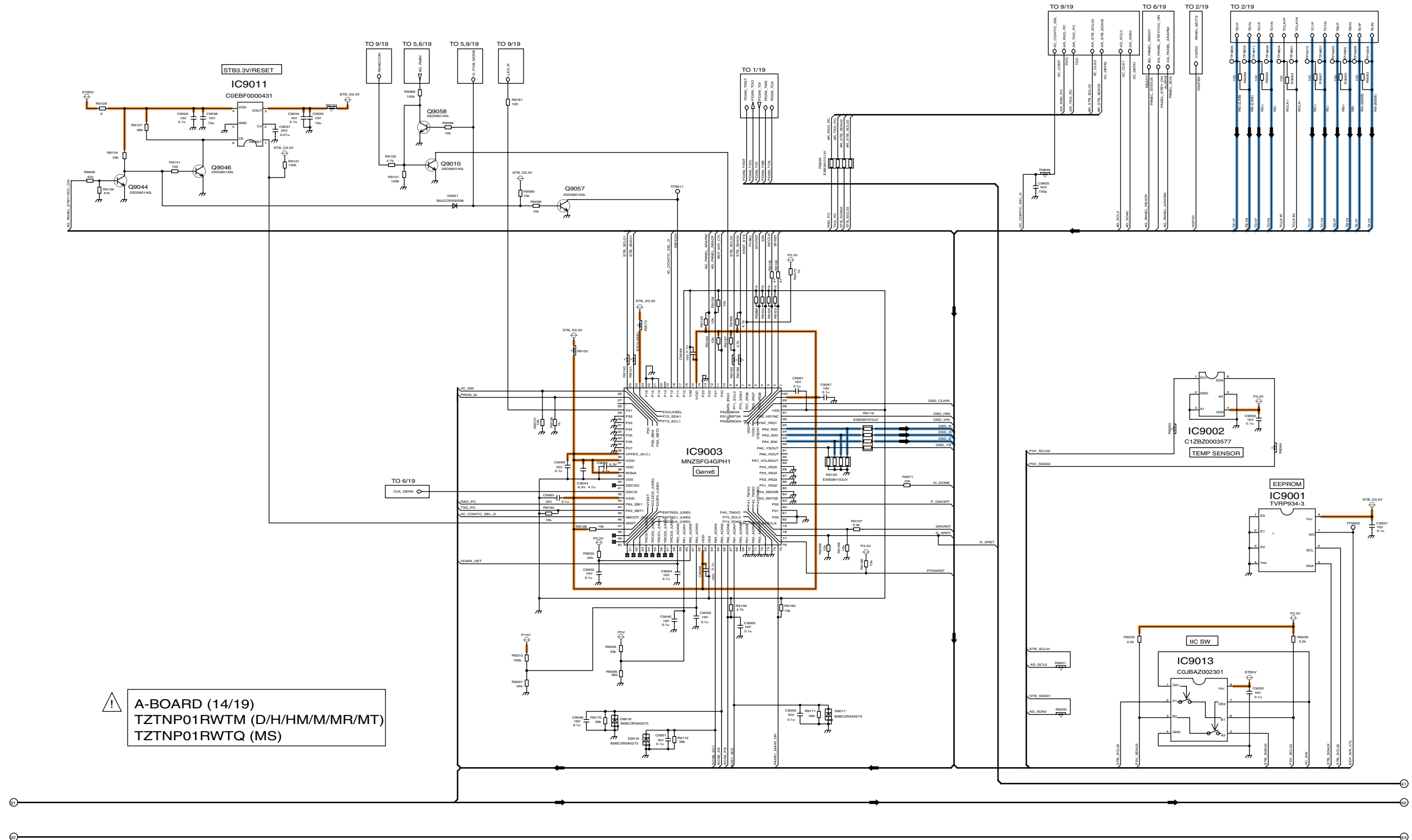

! A-BOARD (14/19)  
TZTNP01RWTM (D/H/HM/M/MR/MT)  
TZTNP01RWTQ (MS)

TH-42PV8D/H/HM/M/MR/MS/MT  
A-Board (14/19) Schematic Diagram

TH-42PV8D/H/HM/M/MR/MS/MT  
A-Board (14/19) Schematic Diagram

# 11.23. A-Board (15/19) Schematic Diagram

! A-BOARD (15/19)  
TZTNP01RWTM (D/H/HM/M/MR/MT)  
TZTNP01RWTQ (MS)

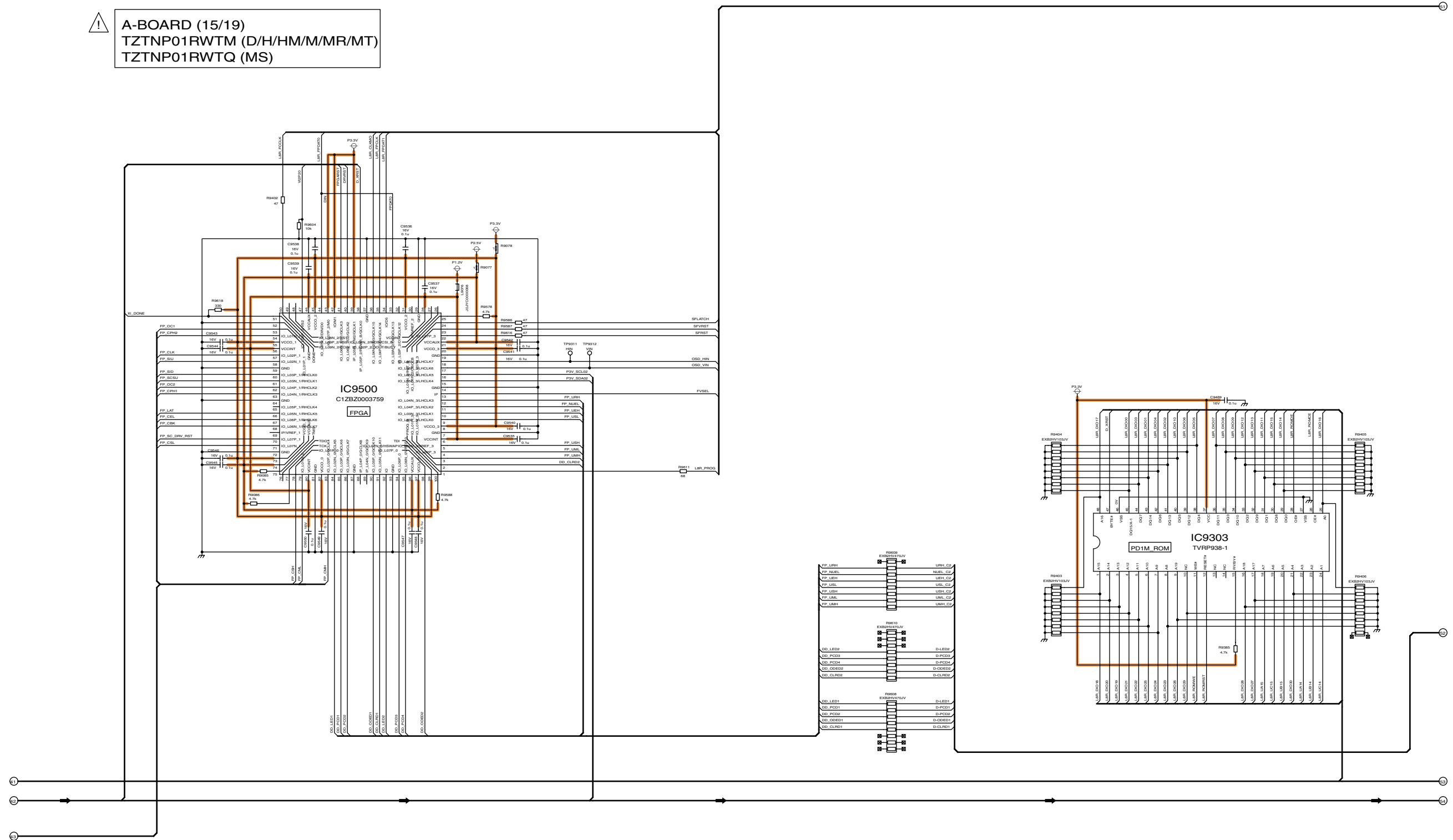

TH-42PV8D/H/HM/M/MR/MS/MT  
A-Board (15/19) Schematic Diagram

TH-42PV8D/H/HM/M/MR/MS/MT  
A-Board (15/19) Schematic Diagram

127

128

129

130

131

132

133

134

135

# 11.24. A-Board (16/19) Schematic Diagram

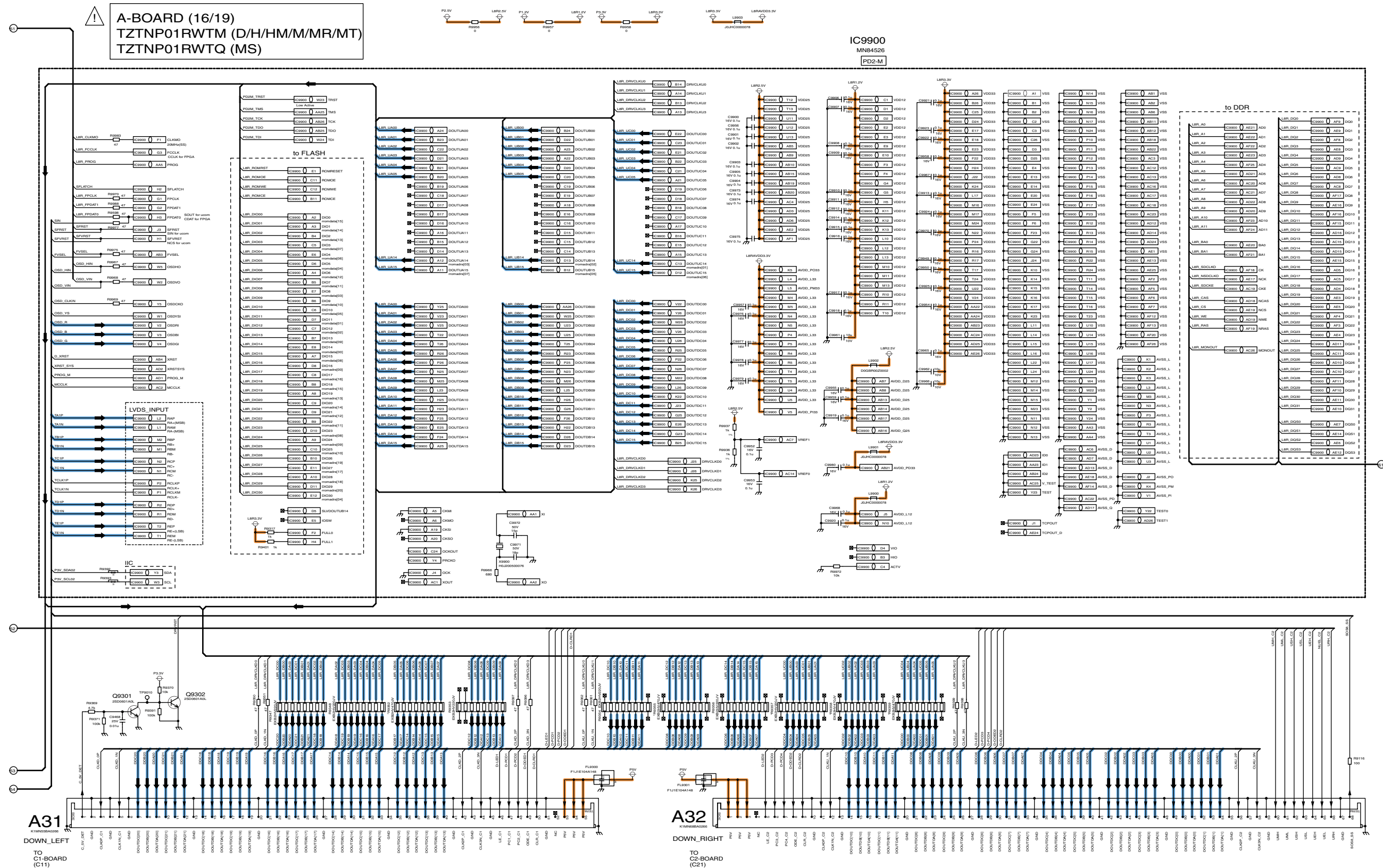

TH-42PV8D/H/HM/M/MR/MS/MT  
 A-Board (16/19) Schematic Diagram

TH-42PV8D/H/HM/M/MR/MS/MT  
 A-Board (16/19) Schematic Diagram

136

137

138

139

140

141

142

143

144

# 11.25. A-Board (17/19) Schematic Diagram

**A-BOARD (17/19)**  
TZTNP01RWTM (D/H/HM/M/MR/MT)  
TZTNP01RWTQ (MS)

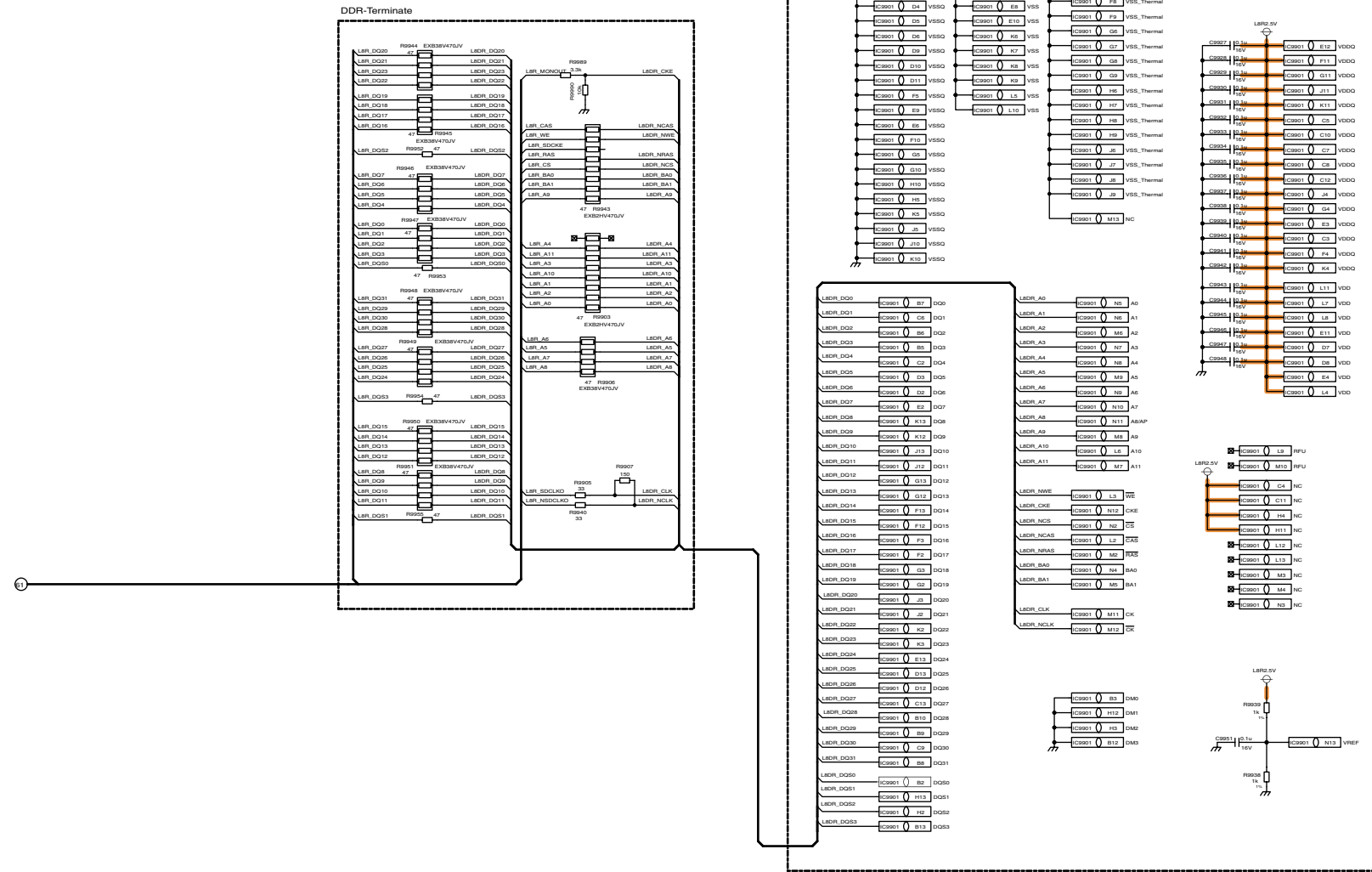



# 11.26. A-Board (18/19) Schematic Diagram

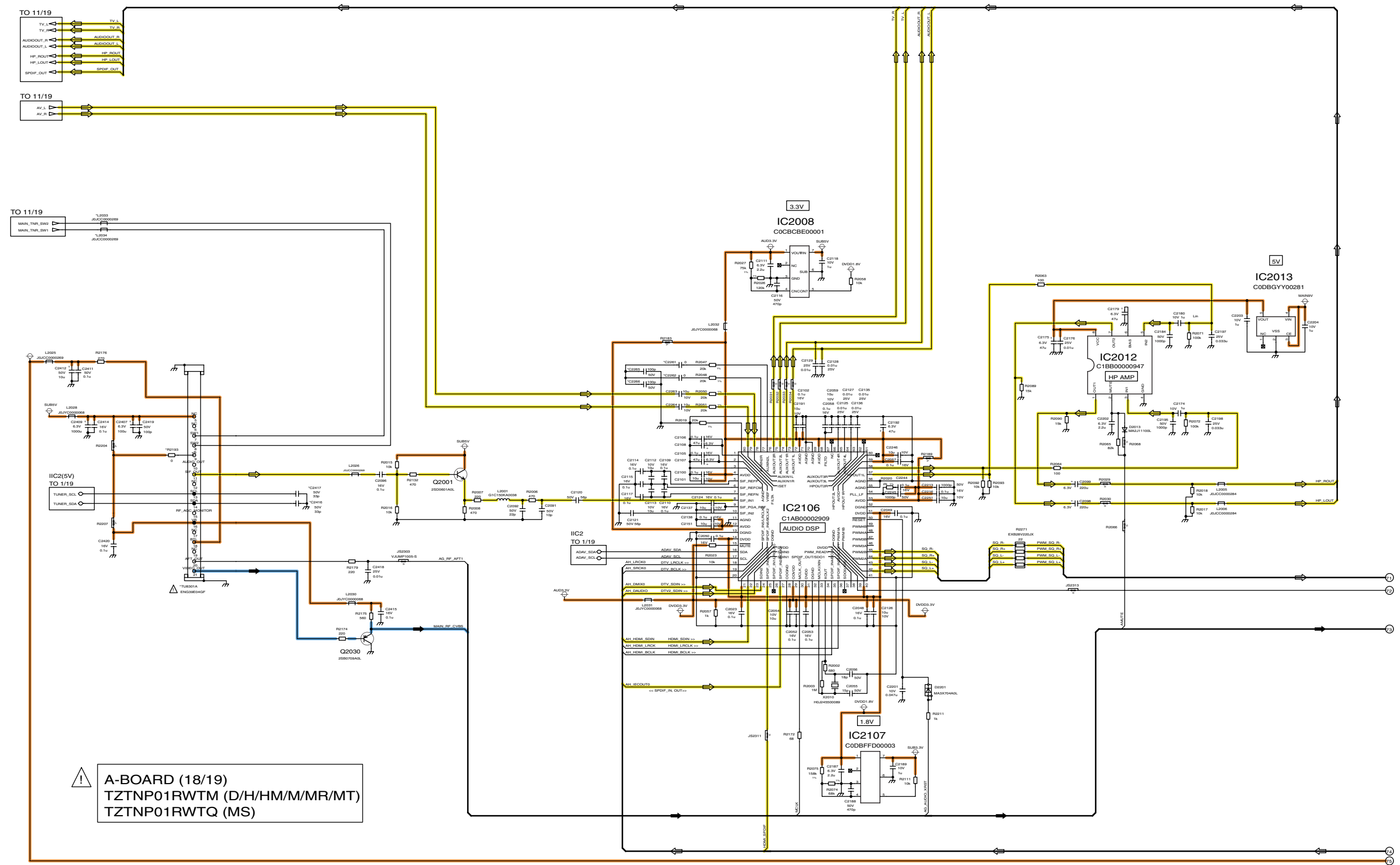

TH-42PV8D/H/HM/M/MR/MS/MT  
A-Board (18/19) Schematic Diagram

TH-42PV8D/H/HM/M/MR/MS/MT  
A-Board (18/19) Schematic Diagram

154

155

156

157

158

159

160

161

162



# 11.27. A-Board (19/19) Schematic Diagram

! A-BOARD (19/19)  
TZTNP01RWTM (D/H/HM/M/MR/MT)  
TZTNP01RWTQ (MS)

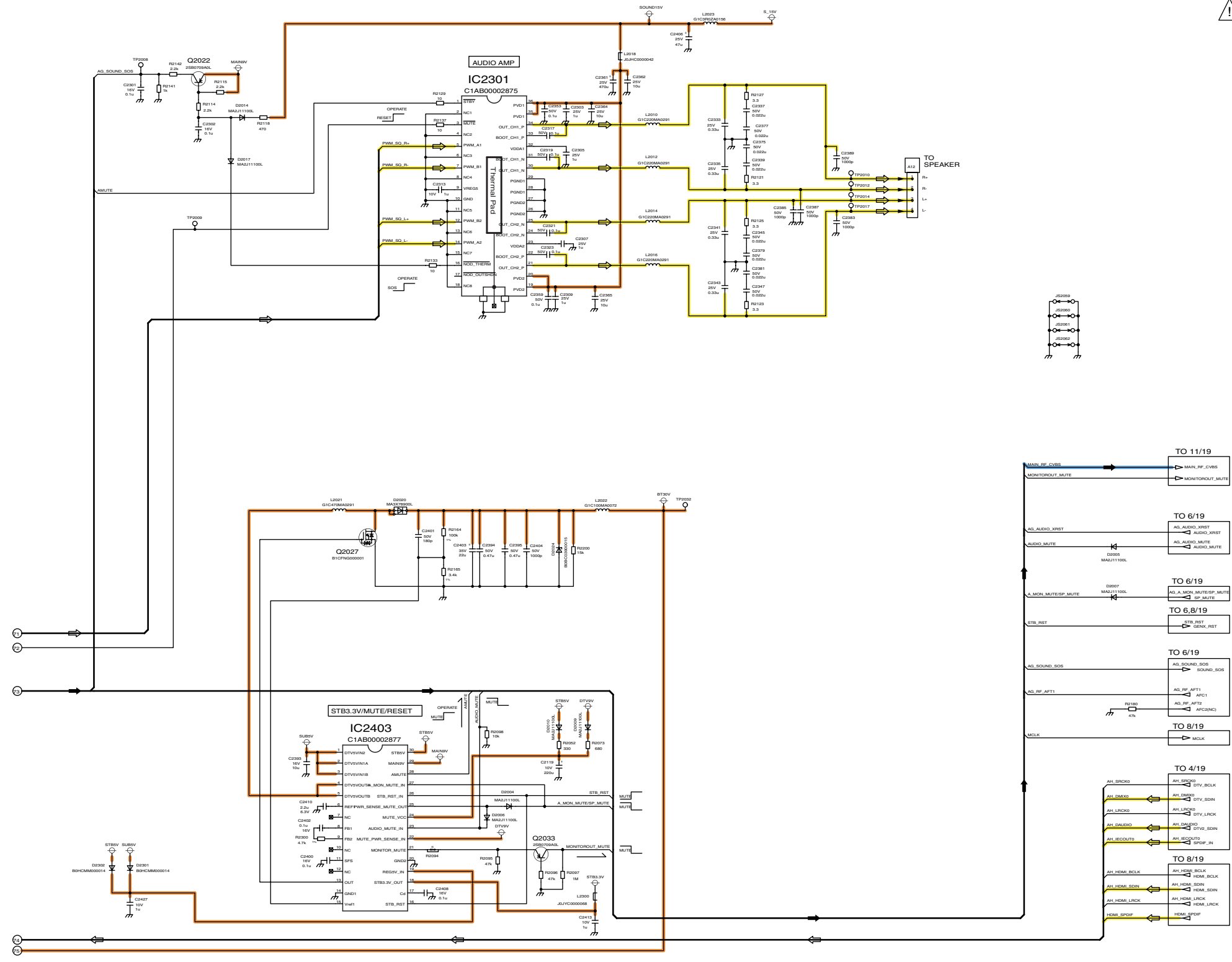

TH-42PV8D/H/HM/M/MR/MS/MT  
A-Board (19/19) Schematic Diagram

TH-42PV8D/H/HM/M/MR/MS/MT  
A-Board (19/19) Schematic Diagram

163

164

165

166

167

168

169

170

171

# 11.28. C1-Board (1/2) Schematic Diagram

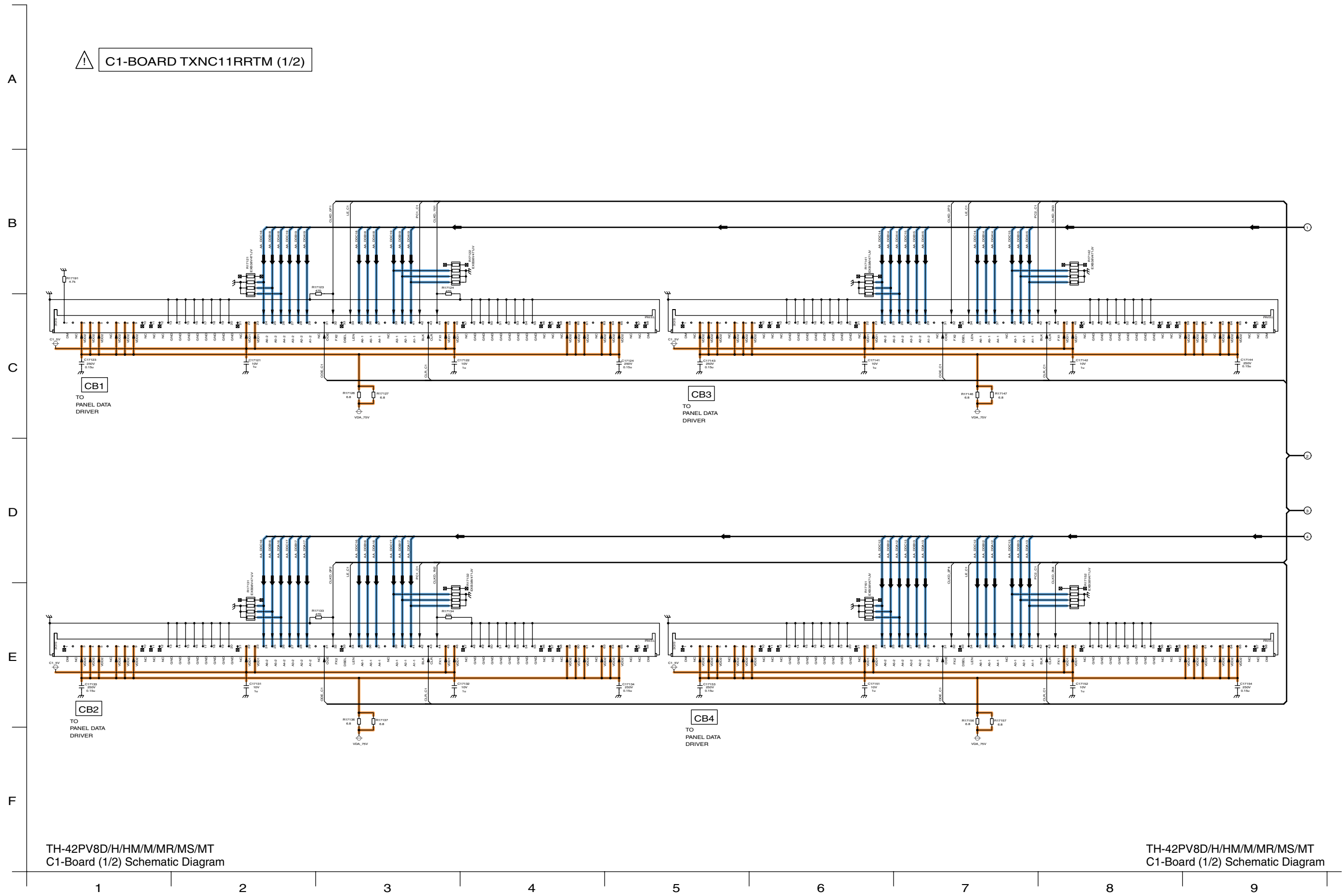

# 11.29. C1-Board (2/2) Schematic Diagram

⚠ C1-BOARD TXNC11RRTM (2/2)

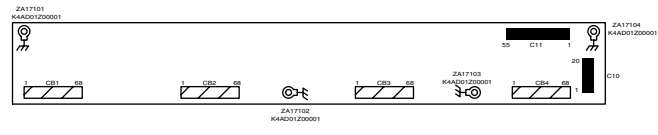
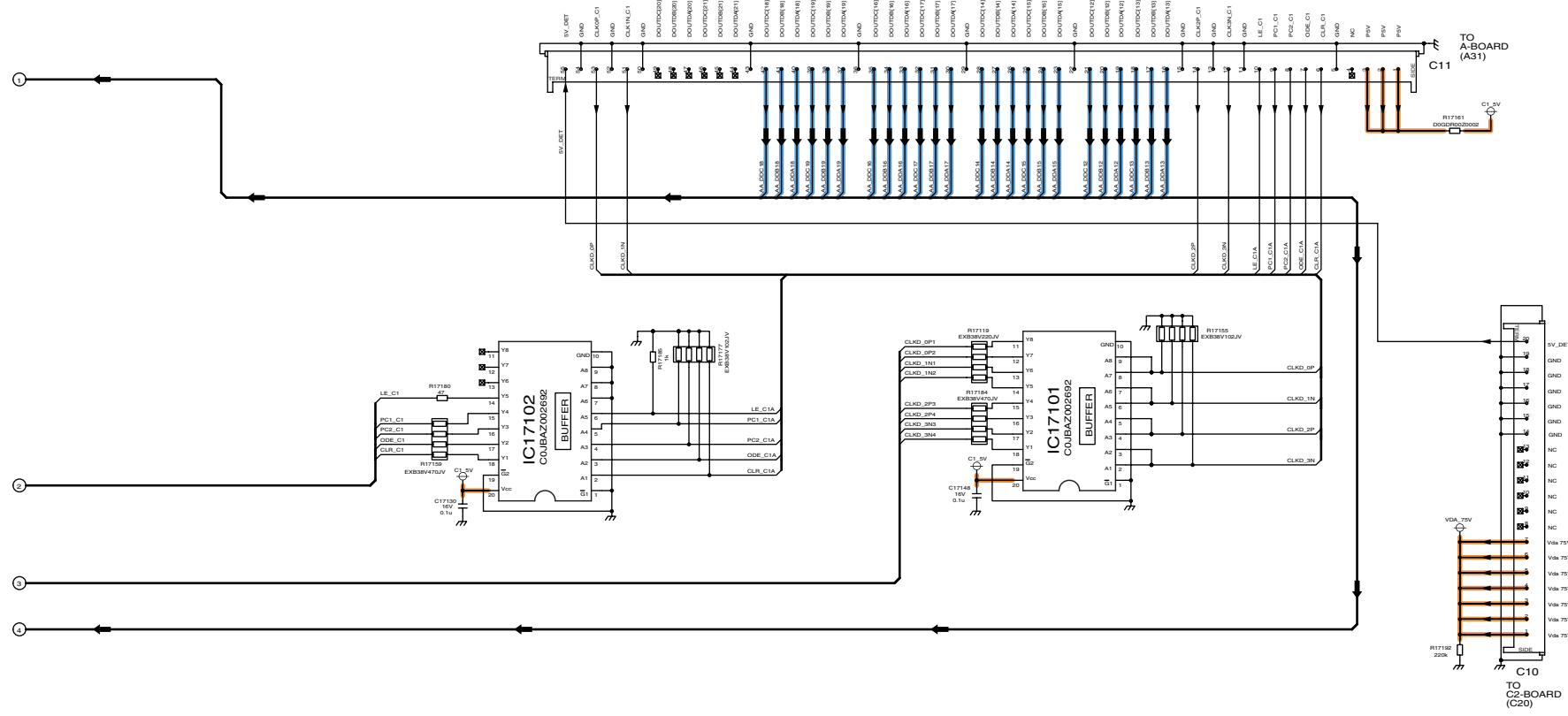

TH-42PV8D/H/HM/M/MR/MS/MT  
C1-Board (2/2) Schematic Diagram

TH-42PV8D/H/HM/M/MR/MS/MT  
C1-Board (2/2) Schematic Diagram

10

11

12

13

14

15

16

17

18

# 11.30. C2-Board (1/2) Schematic Diagram

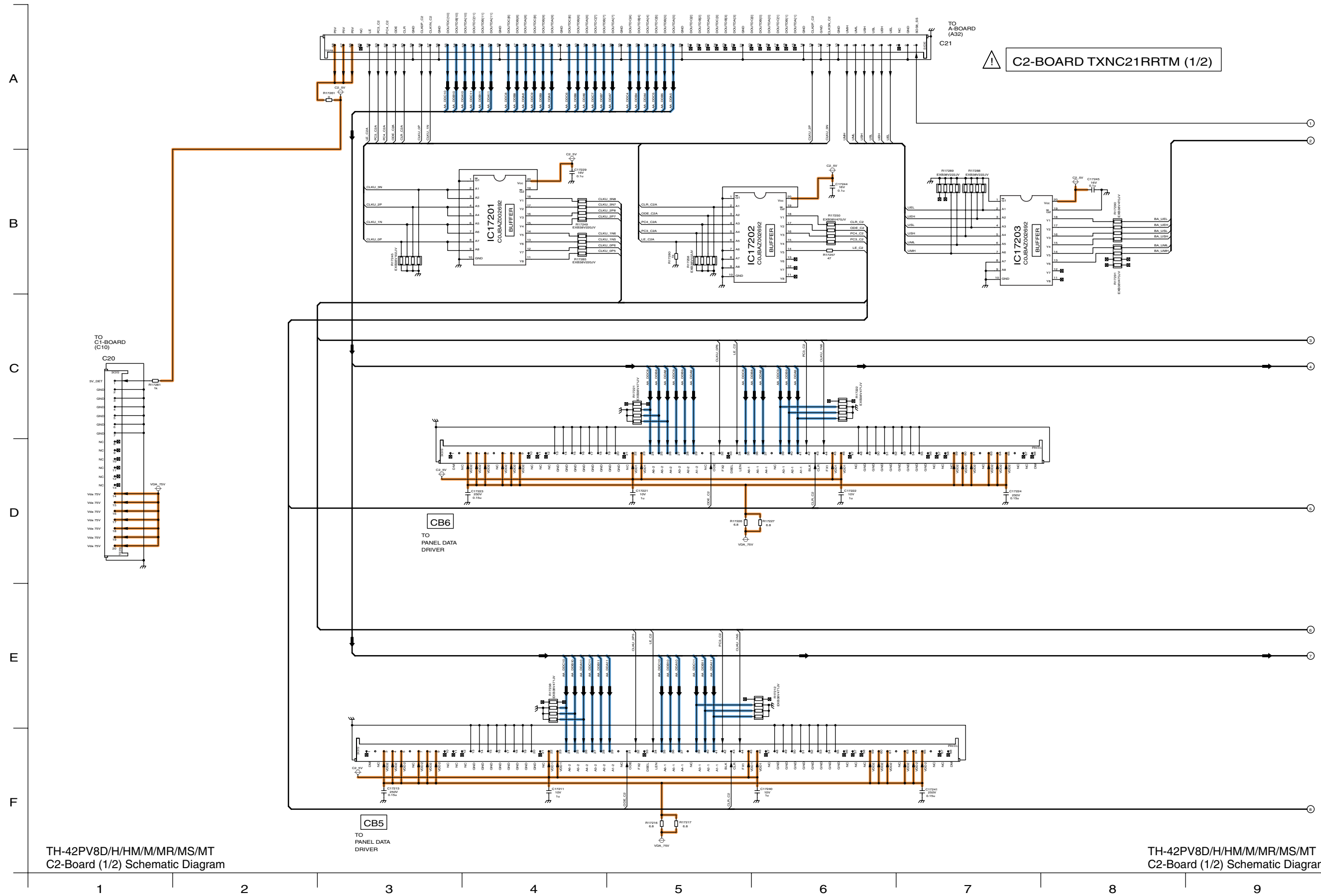

TH-42PV8D/H/HM/M/MR/MS/MT  
C2-Board (1/2) Schematic Diagram

TH-42PV8D/H/HM/M/MR/MS/MT  
C2-Board (1/2) Schematic Diagram

# 11.31. C2-Board (2/2) Schematic Diagram

 C2-BOARD TXNC21RRTM (2/2)

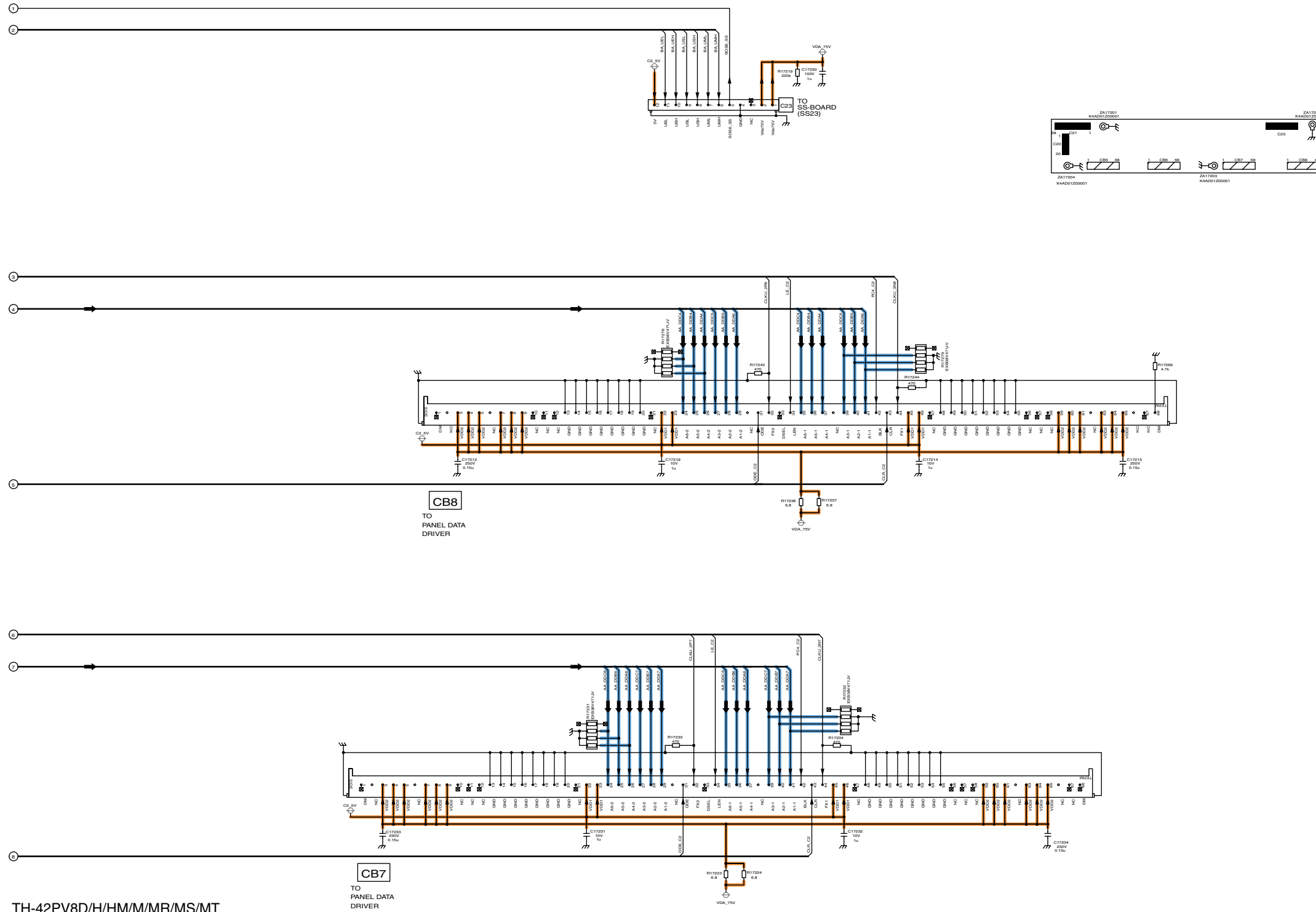

TH-42PV8D/H/HM/M/MR/MS/MT  
C2-Board (2/2) Schematic Diagram

TH-42PV8D/H/HM/M/MR/MS/MT  
C2-Board (2/2) Schematic Diagram

10

11

12

13

14

15

16

17

18

# 11.32. SC-Board (1/3) Schematic Diagram

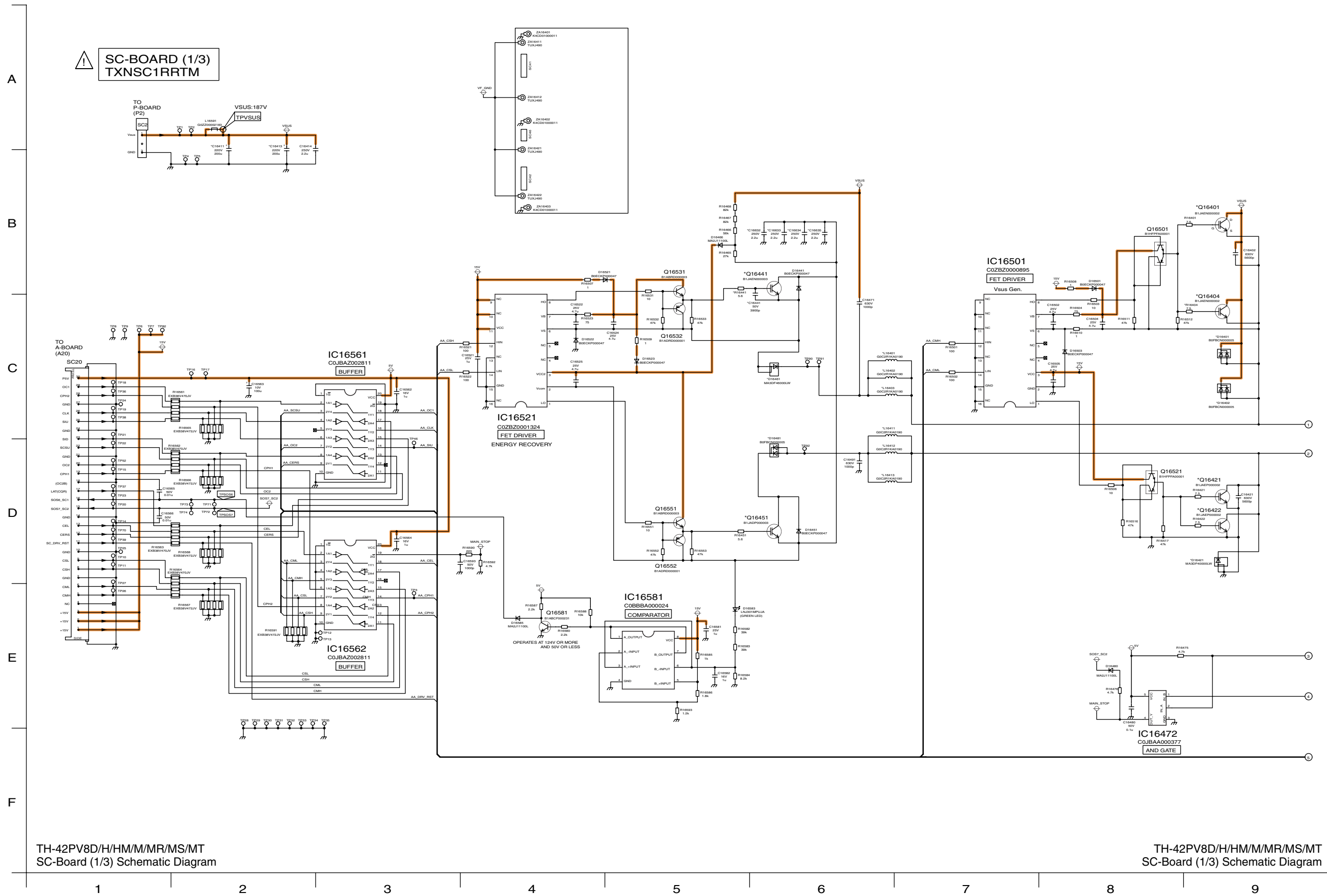

# 11.33. SC-Board (2/3) Schematic Diagram

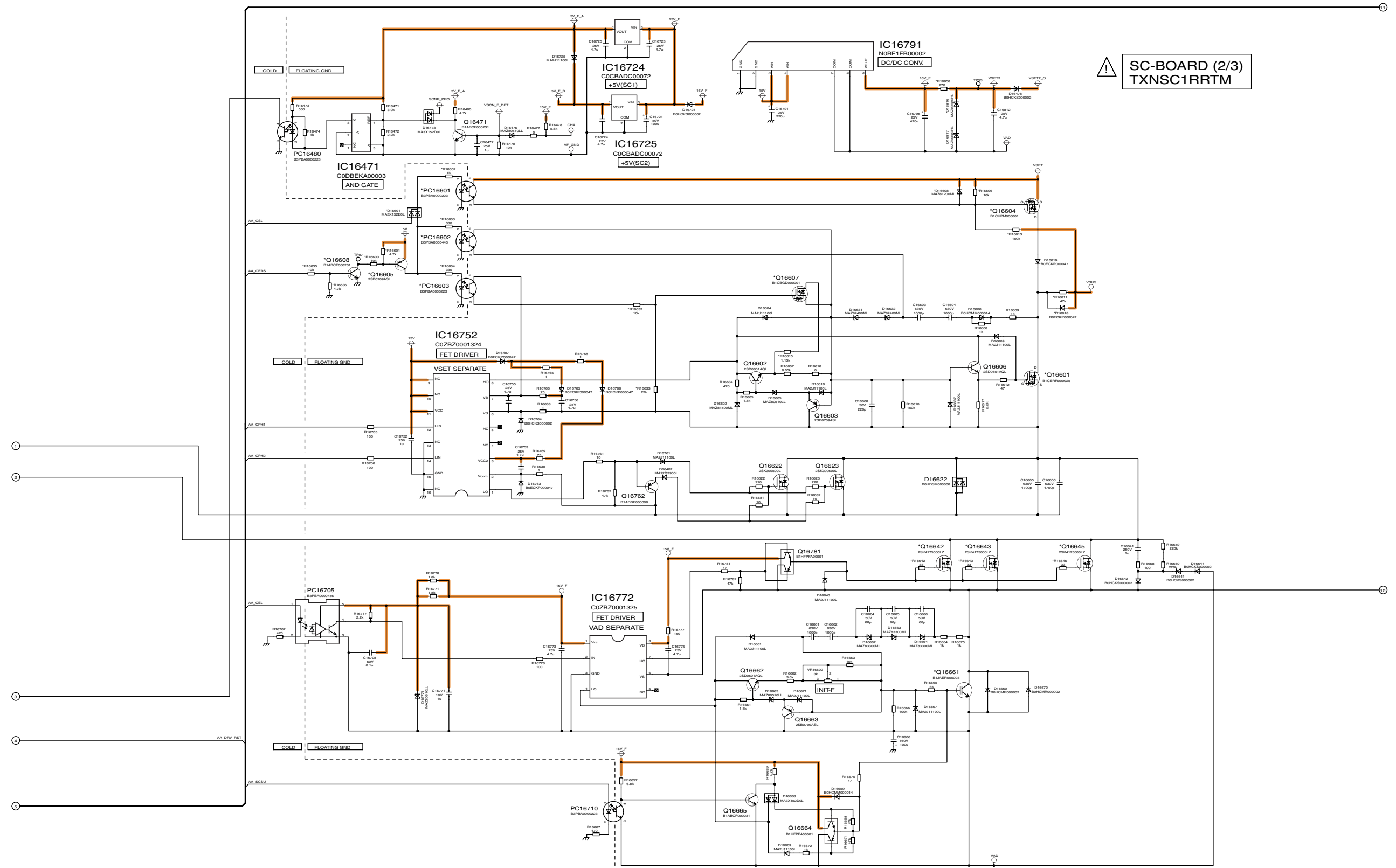

SC-BOARD (2/3)  
TXNSC1RRTM

TH-42PV8D/H/HM/M/MR/MS/MT  
SC-Board (2/3) Schematic Diagram

TH-42PV8D/H/HM/M/MR/MS/MT  
SC-Board (2/3) Schematic Diagram

10

11

12

13

14

15

16

17

18

# 11.34. SC-Board (3/3) Schematic Diagram

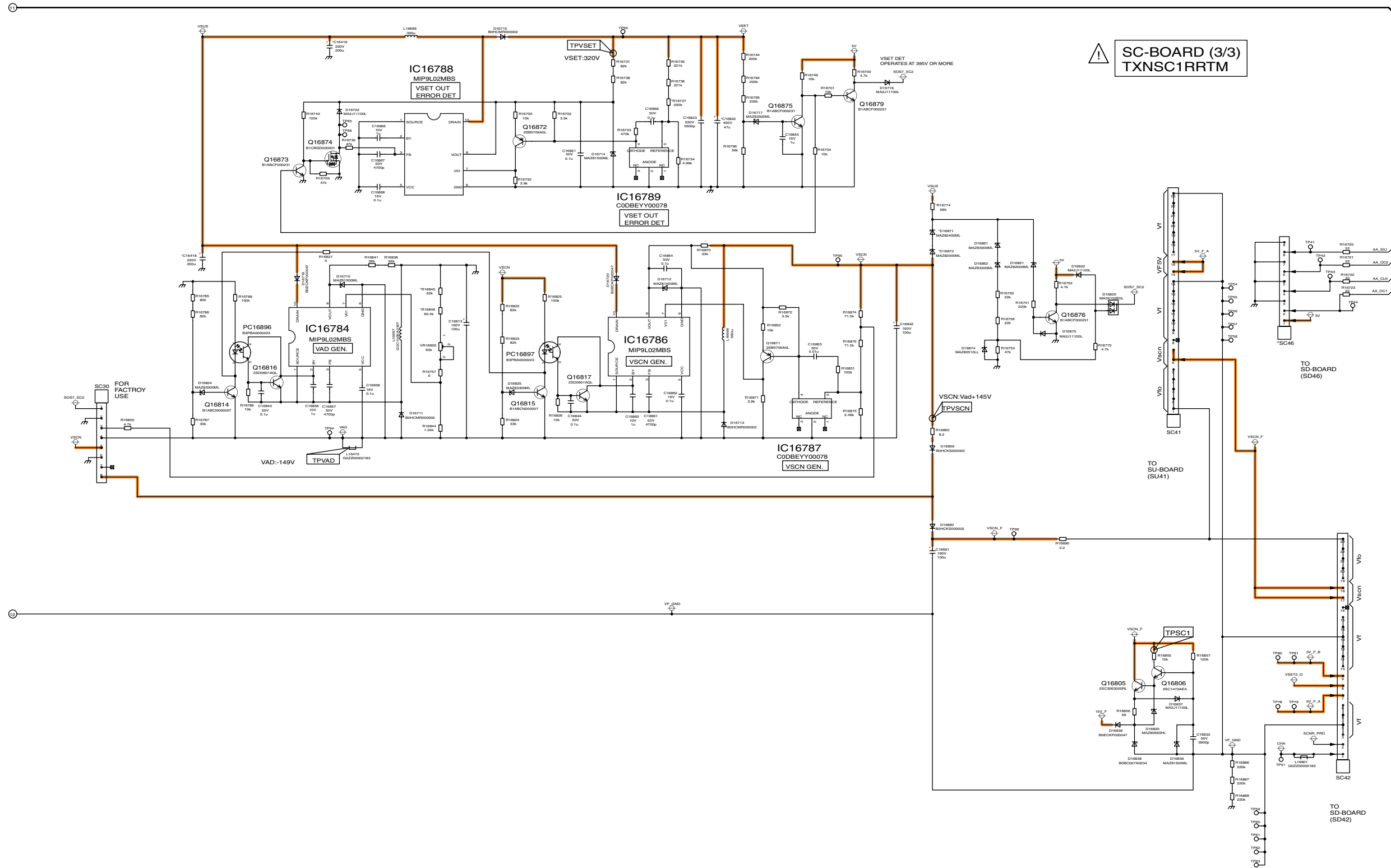

TH-42PV8D/H/HM/M/MR/MS/MT  
SC-Board (3/3) Schematic Diagram

TH-42PV8D/H/HM/M/MR/MS/MT  
SC-Board (3/3) Schematic Diagram

19

20

21

22

23

24

25

26

27



# 11.35. SU-Board (1/2) Schematic Diagram

⚠ SU-BOARD TXNSU1RRTM (1/2)

A  
B  
C  
D  
E  
F

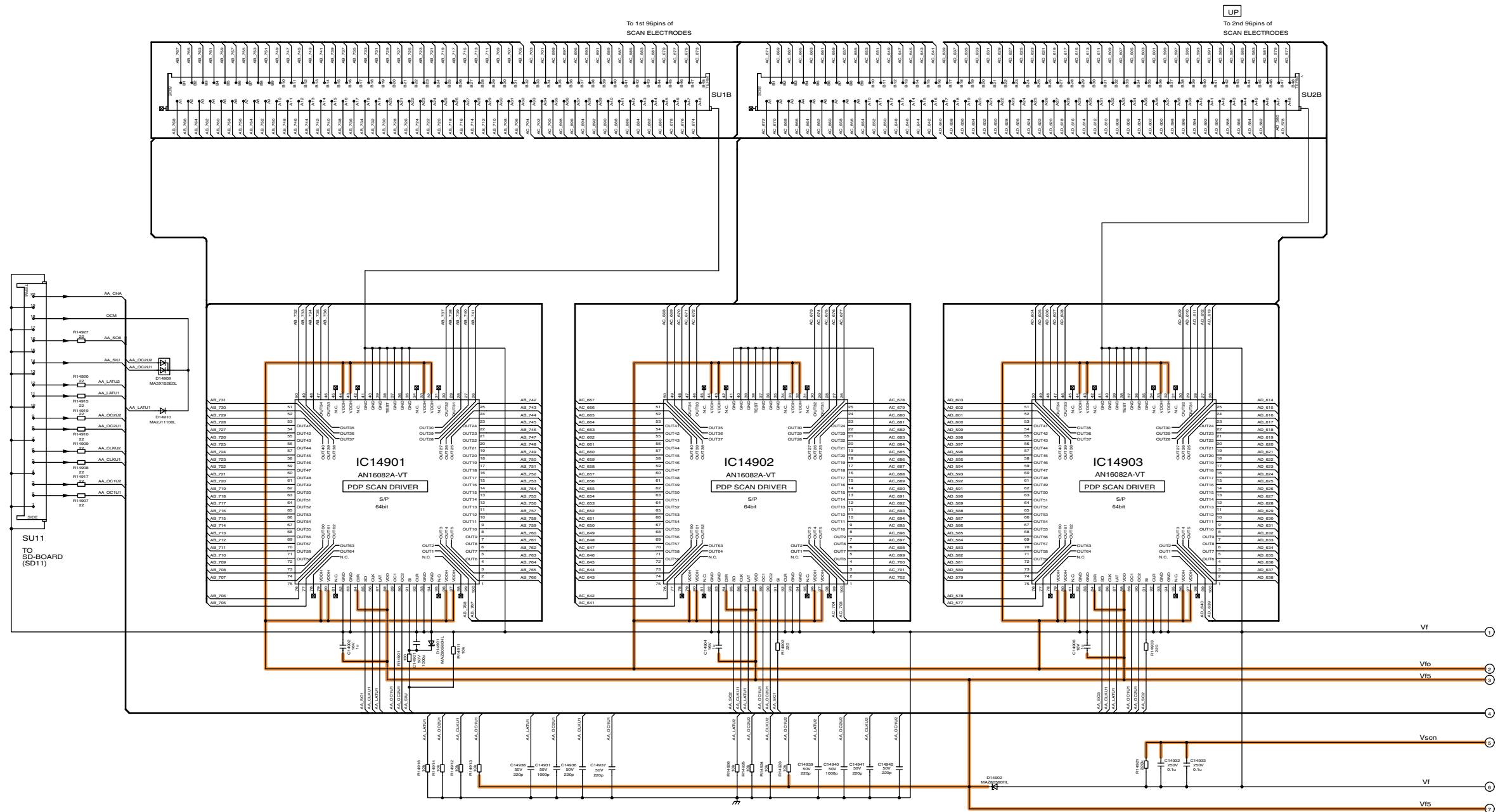

TH-42PV8D/H/HM/M/MR/MS/MT  
SU-Board (1/2) Schematic Diagram

TH-42PV8D/H/HM/M/MR/MS/MT  
SU-Board (1/2) Schematic Diagram

1 2 3 4 5 6 7 8 9

# 11.36. SU-Board (2/2) Schematic Diagram

! SU-BOARD TXNSU1RRTM (2/2)

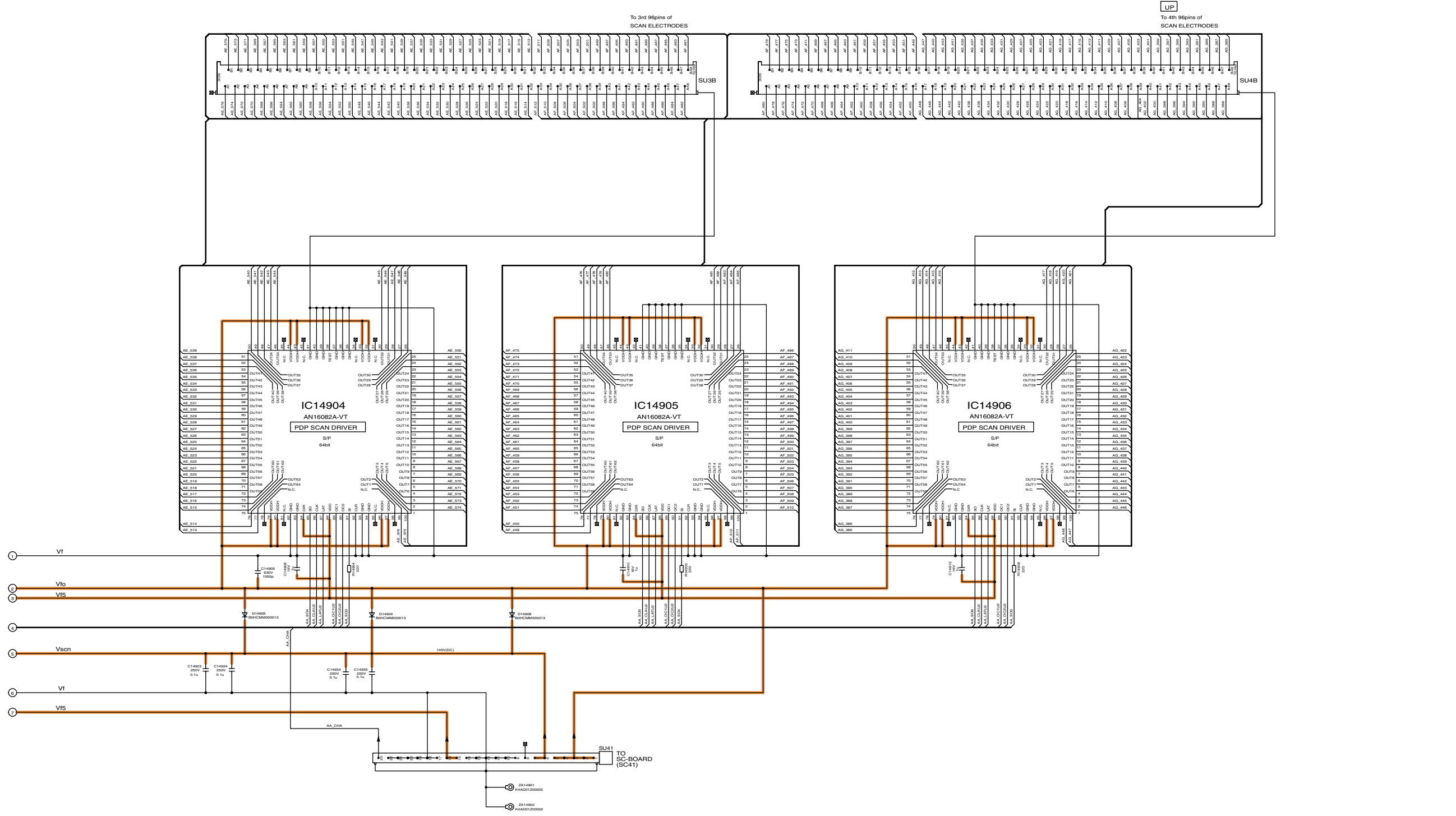

TH-42PV8D/H/HM/MR/MS/MT  
SU-Board (2/2) Schematic Diagram

TH-42PV8D/H/HM/MR/MS/MT  
SU-Board (2/2) Schematic Diagram

10

11

12

13

14

15

16

17

18

# 11.37. SD-Board (1/2) Schematic Diagram

⚠ SD-BOARD TXNSD1RRTM (1/2)

A

B

C

D

E

F

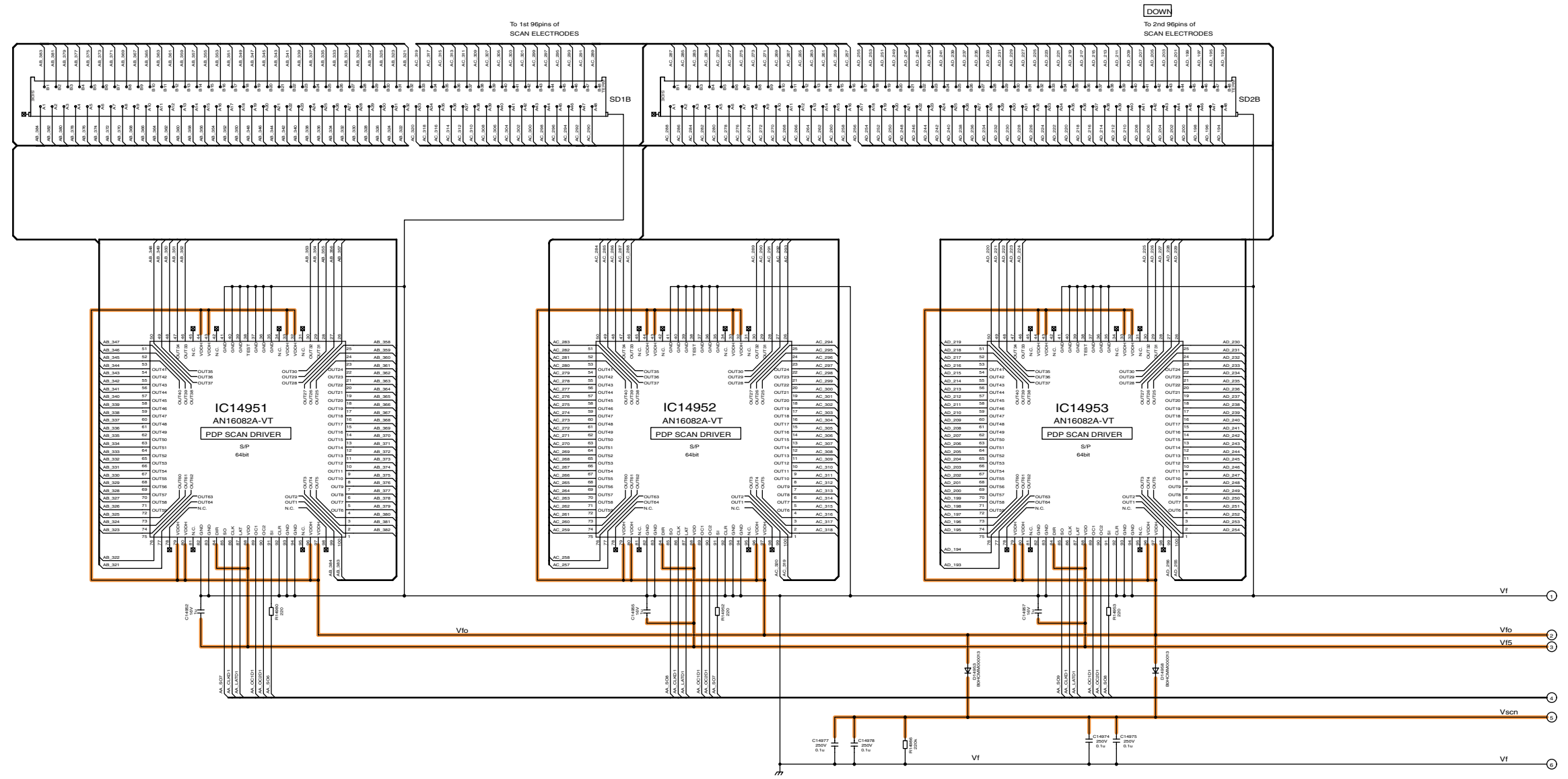

TH-42PV8D/H/HM/M/MR/MS/MT  
SD-Board (1/2) Schematic Diagram

TH-42PV8D/H/HM/M/MR/MS/MT  
SD-Board (1/2) Schematic Diagram

1

2

3

4

5

6

7

8

9

# 11.38. SD-Board (2/2) Schematic Diagram

SD-BOARD TXNSD1RRTM (2/2)

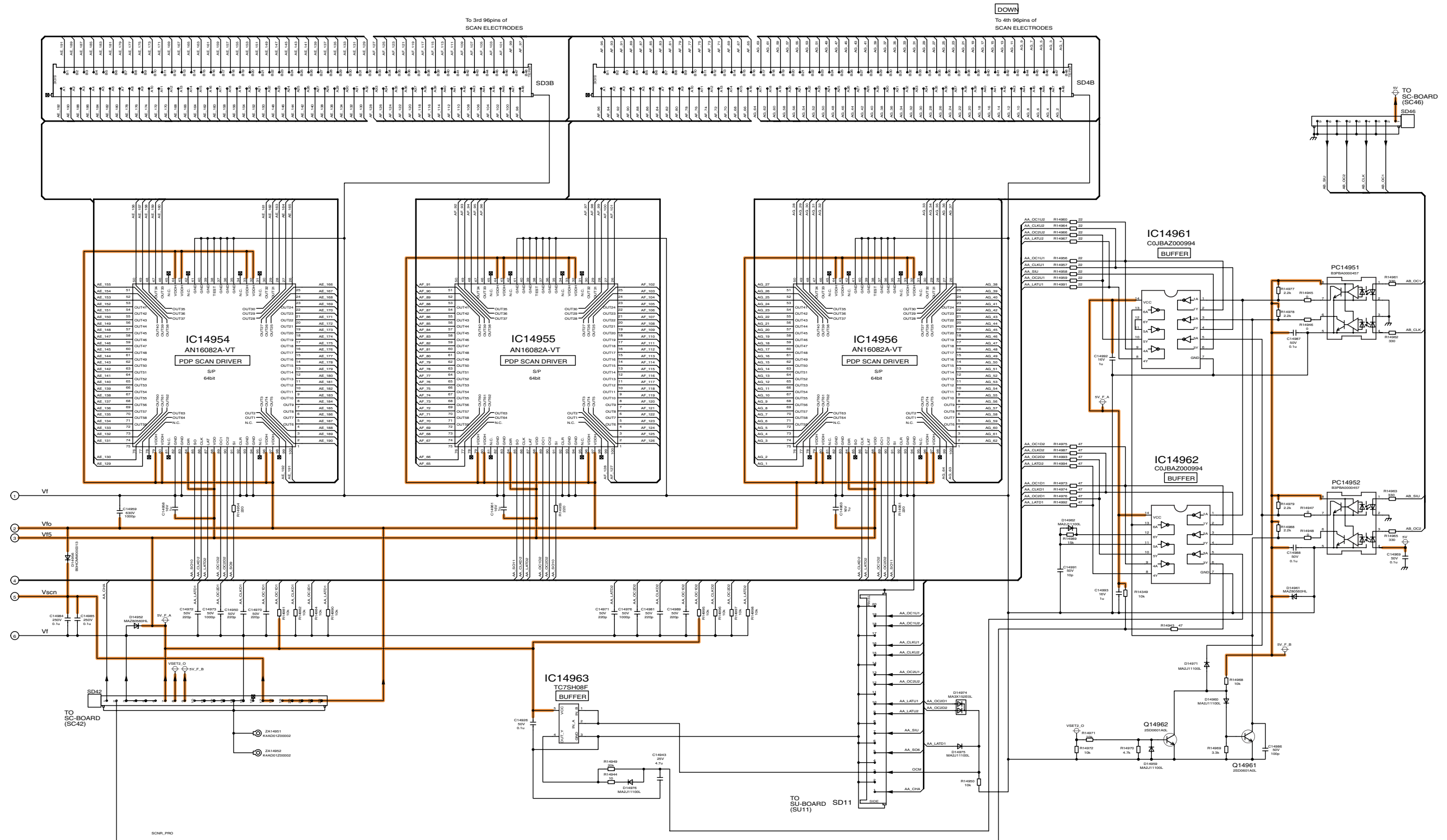

TH-42PV8D/H/HM/MR/MS/MT  
SD-Board (2/2) Schematic Diagram

TH-42PV8D/H/HM/MR/MS/MT  
SD-Board (2/2) Schematic Diagram

10

11

12

13

14

15

16

17

18

# 11.39. SS-Board (1/2) and S-Board Schematic Diagram

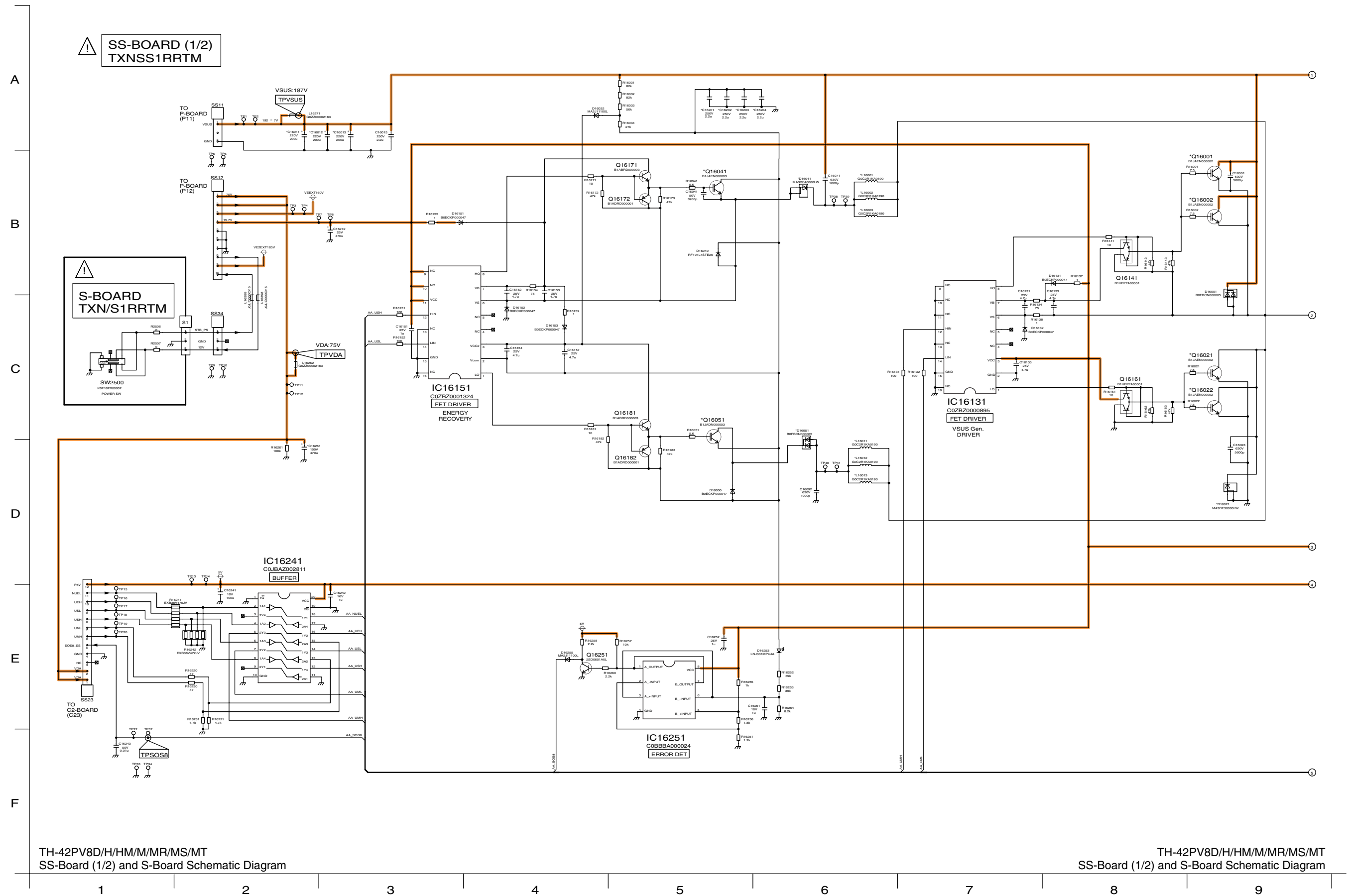

# 11.40. SS-Board (2/2) Schematic Diagram

⚠ SS-BOARD (2/2)  
TXNSS1RRTM

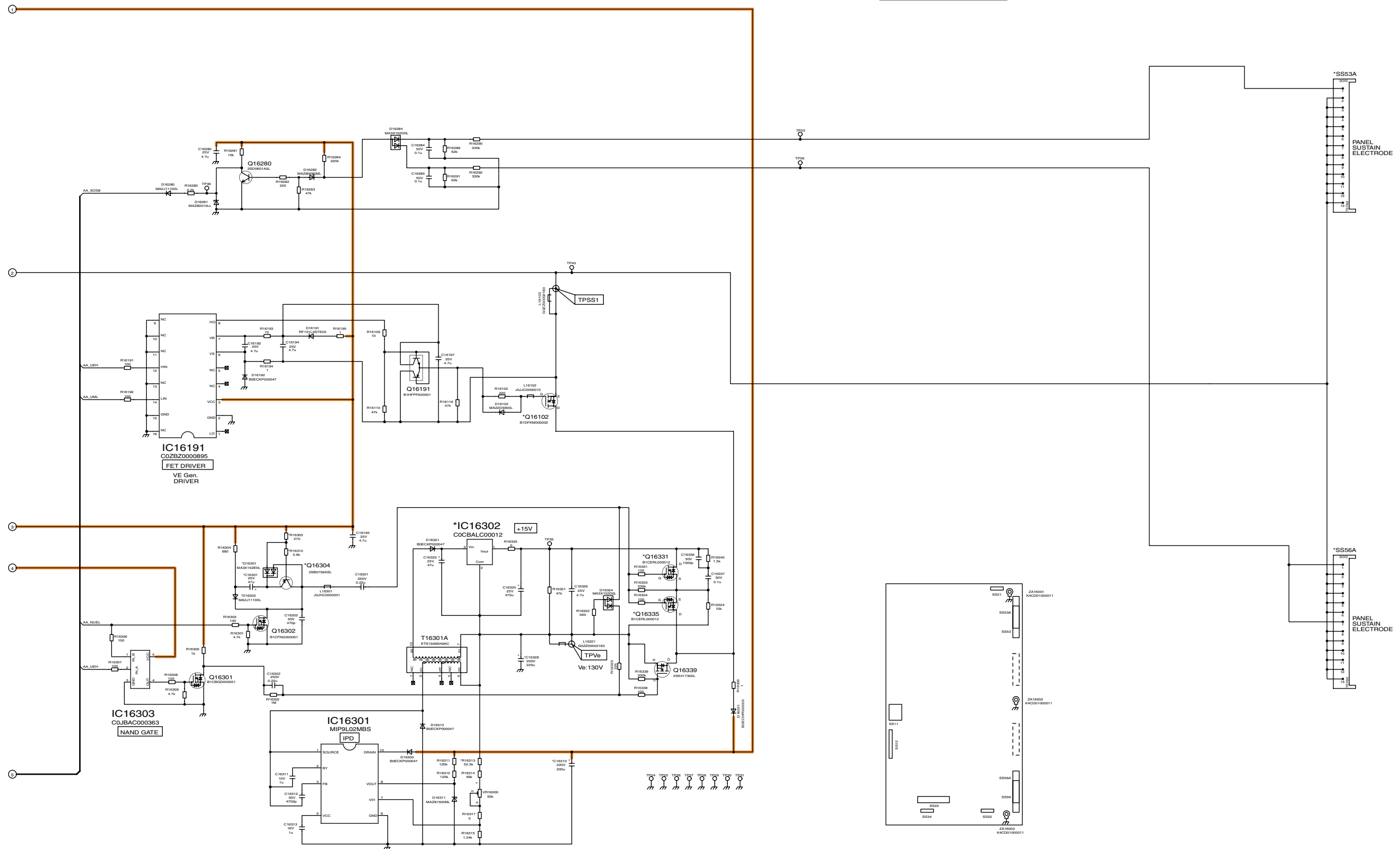

TH-42PV8D/H/HM/M/MR/MS/MT  
SS-Board (2/2) Schematic Diagram

TH-42PV8D/H/HM/M/MR/MS/MT  
SS-Board (2/2) Schematic Diagram

10 11 12 13 14 15 16 17 18

# 12 Printed Circuit Board

## 12.1. P-Board

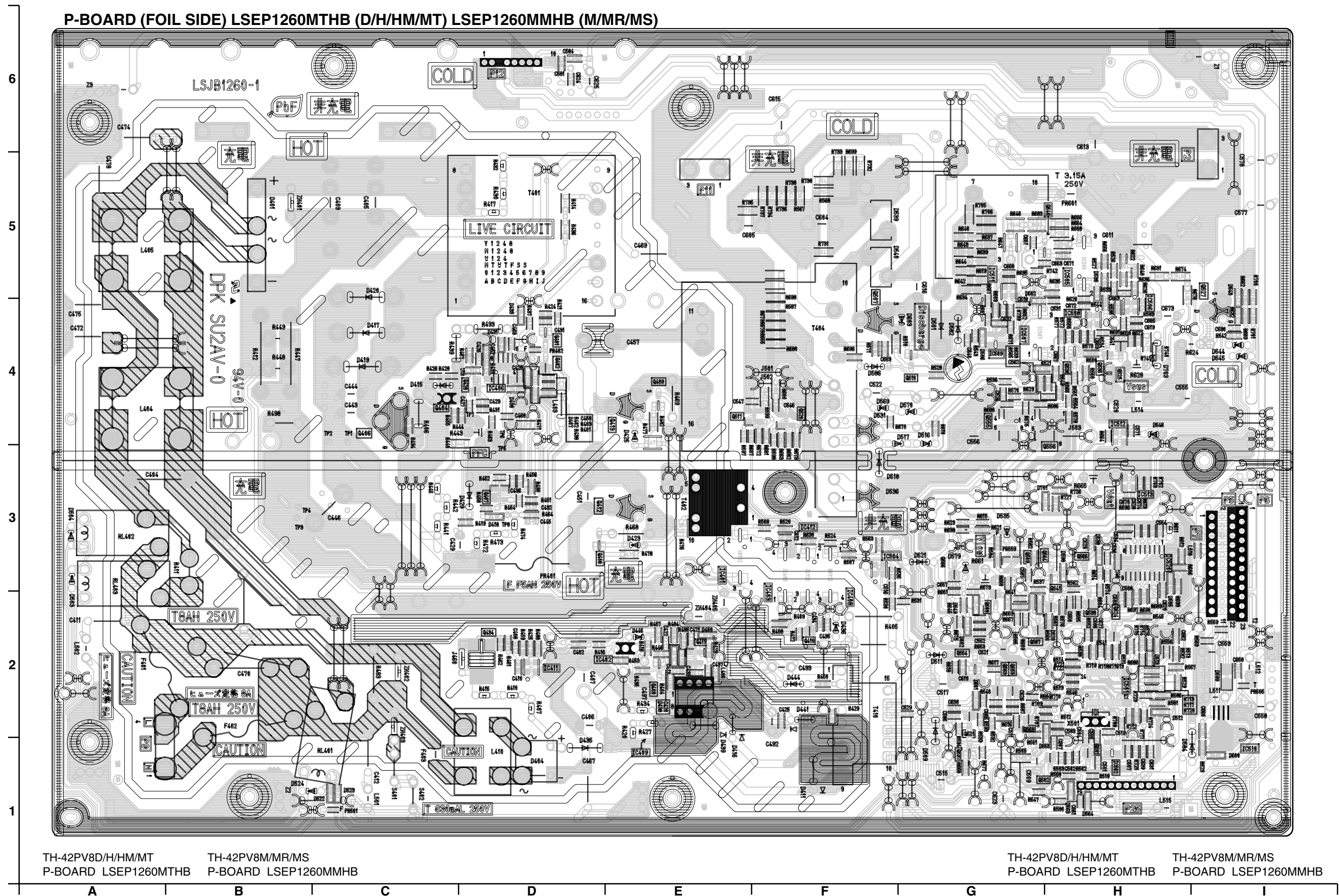



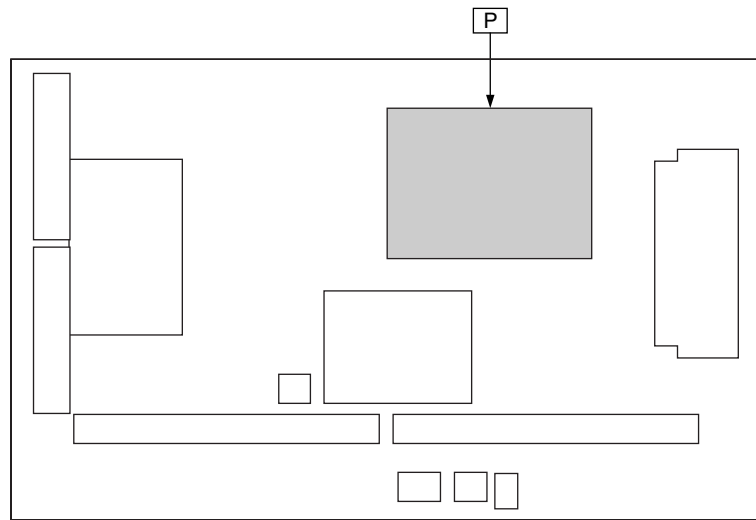

**Parts Location**

P-BOARD (FOIL SIDE)					
IC		TRANSISTOR		VOLUME	
IC401	E-3	Q401	D-4	Q530	H-4
IC402	E-2	Q402	D-4	Q535	H-4
IC403	F-2	Q403	E-3	Q537	G-1
IC406	D-4	Q404	C-4	Q538	H-2
IC408	F-2	Q406	C-4	Q540	H-5
IC409	E-1	Q407	D-3	Q541	H-3
IC411	D-2	Q408	D-3	Q553	G-2
IC412	F-3	Q409	E-4	Q554	G-2
IC501	H-2	Q410	F-2	Q555	G-4
IC502	H-1	Q411	E-2	Q556	H-4
IC504	F-3	Q412	D-3	Q563	G-2
IC505	H-5	Q413	E-4	Q564	G-3
IC506	H-5	Q420	D-4	Q565	H-3
IC507	G-4	Q434	D-2	Q567	G-2
IC508	H-4	Q501	H-1	Q569	G-2
IC509	G-4	Q502	G-1		
IC510	I-1	Q507	F-5	<b>VOLUME</b>	
IC511	G-5	Q508	G-2	R443	C-4
IC512	H-4	Q509	G-3	R628	H-4
IC513	H-3	Q510	G-4	R661	G-3
IC520	H-3	Q517	E-4	R665	H-3
		Q520	F-4		
		Q521	G-2		
		Q524	H-2		
		Q525	H-4		
		Q527	I-5		

TH-42PV8D/H/HM/M/MR/MS/MT  
P-BOARD PARTS LOCATION

**Parts Location**

P-BOARD (COMPONENT SIDE)					
IC		TRANSISTOR		VOLUME	
IC402	E-2	Q404	F-4	R443	F-4
IC409	E-2	Q406	G-4	R628	B-4
		Q412	E-3	R661	C-3
		Q413	E-4	R665	B-3
		Q507	D-4		
		Q527	A-5		

TH-42PV8D/H/HM/M/MR/MS/MT  
P-BOARD PARTS LOCATION



P-BOARD (COMPONENT SIDE) LSEP1260MTHB (D/H/HM/MT) LSEP1260MMHB (M/MR/MS)

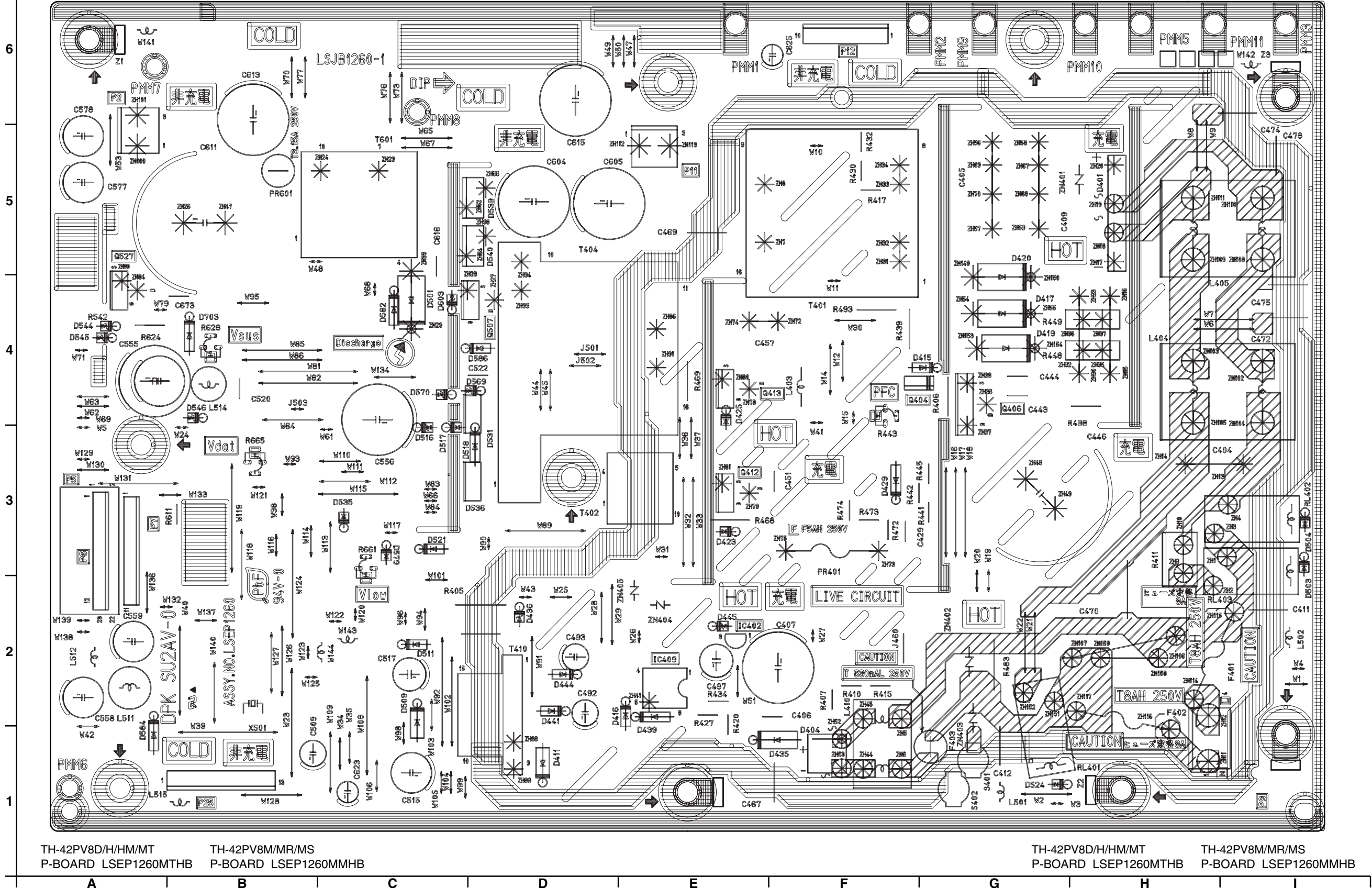

TH-42PV8D/H/HM/MT P-BOARD LSEP1260MTHB  
 TH-42PV8M/MR/MS P-BOARD LSEP1260MMHB

TH-42PV8D/H/HM/MT P-BOARD LSEP1260MTHB  
 TH-42PV8M/MR/MS P-BOARD LSEP1260MMHB

## 12.2. G, GS, K and S-Board

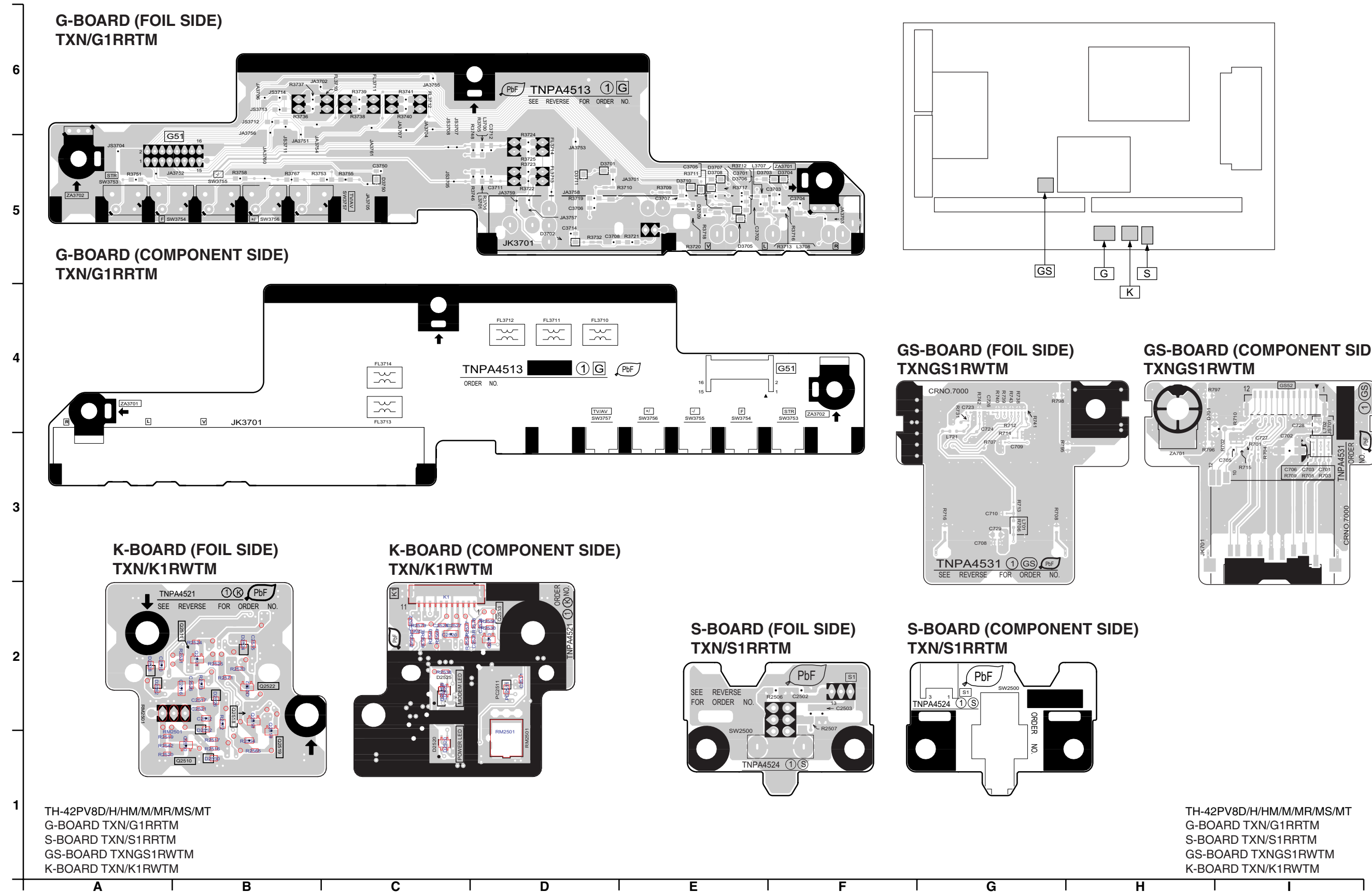



### 12.3. A-Board

**A-BOARD (FOIL SIDE)**  
**TZTNP01RWTM(D/H/HM/M/MR/MT) TZTNP01RWTQ(MS)**

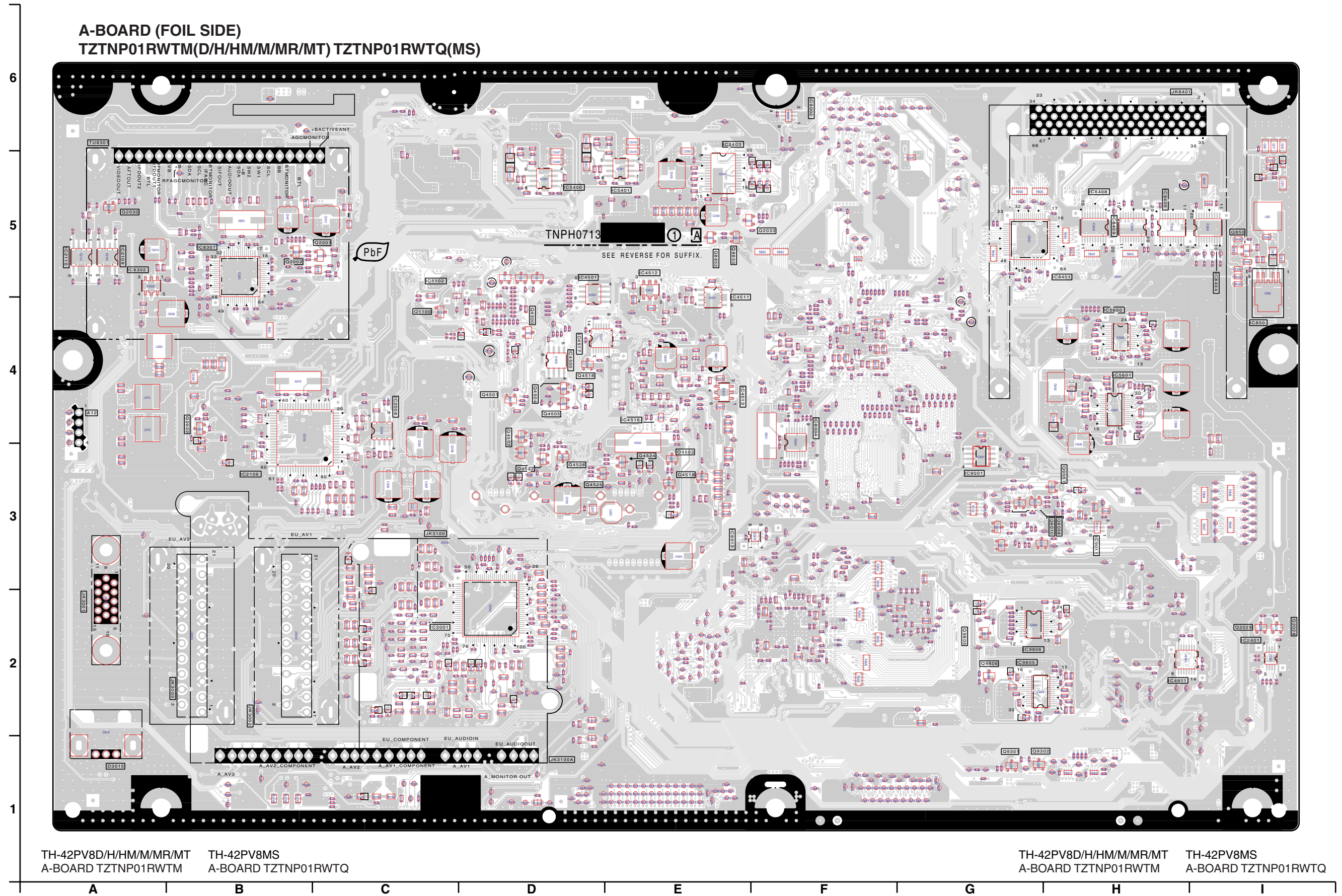

TH-42PV8D/H/HM/M/MR/MT  
 A-BOARD TZTNP01RWTM

TH-42PV8MS  
 A-BOARD TZTNP01RWTQ

TH-42PV8D/H/HM/M/MR/MT  
 A-BOARD TZTNP01RWTM

TH-42PV8MS  
 A-BOARD TZTNP01RWTQ

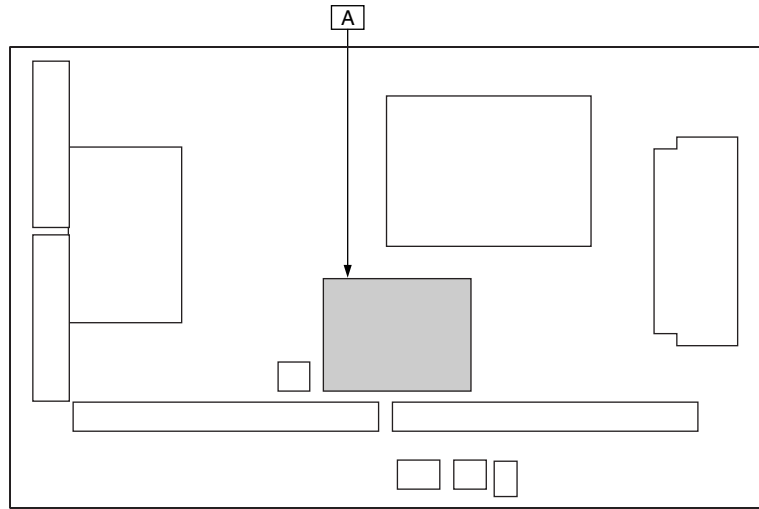

**Parts Location**

A-BOARD (FOIL SIDE)					
IC		TRANSISTOR		TEST POINT	
IC850	I-4	Q850	I-5	TP0190	F-5
IC1102	C-5	Q1100	C-4	TP0191	G-2
IC2008	C-4	Q2001	C-5	TP0192	F-5
IC2106	B-3	Q2002	B-5	TP0193	F-5
IC2109	A-5	Q2022	B-4	TP0194	F-5
IC2110	A-5	Q2028	I-2	TP1042	G-4
IC2401	I-2	Q2029	I-2	TP1043	G-4
IC2403	E-6	Q2030	A-5	TP1102	D-4
IC3001	C-2	Q2033	F-5	TP1103	D-4
IC4500	D-4	Q4500	D-4	TP1104	D-5
IC4501	D-5	Q4501	D-4	TP1105	D-5
IC4511	E-4	Q4502	D-4	TP1107	D-5
IC4512	E-5	Q4503	E-3	TP2008	B-4
IC4513	E-4	Q4504	D-4	TP2009	B-4
IC4516	E-4	Q4505	D-4	TP2010	A-4
IC4517	D-4	Q4518	D-4	TP2012	A-4
IC4811	H-2	Q4519	E-3	TP2014	A-4
IC5400	D-5	Q4524	E-3	TP2017	A-4
IC5401	E-5	Q4525	D-3	TP2030	B-5
IC5600	H-4	Q4526	D-3	TP2031	B-5
IC5601	H-4	Q4527	D-3	TP2032	C-5
IC8004	F-4	Q8852	E-5	TP3000	D-1
IC8301	B-5	Q8853	E-5	TP3001	C-1
IC8302	A-5	Q9010	H-3	TP3002	D-1
IC8401	H-5	Q9057	H-3	TP3003	C-1
IC8404	I-5	Q9058	H-3	TP3004	D-3
IC8405	H-5	Q9301	G-1	TP3005	D-3
IC8408	H-5	Q9302	G-1	TP3006	D-3
IC8409	H-5	Q9805	G-2	TP3007	D-3
IC9001	G-3	Q9806	G-2	TP3008	E-4
IC9002	F-6			TP3009	E-4
IC9011	H-3			TP3013	D-2
IC9013	E-3			TP3014	A-3
IC9805	G-2			TP3015	C-3
IC9806	G-2			TP3017	D-1
				TP3018	D-1
				TP3019	D-1
				TP3020	C-1
				TP3021	D-3
				TP4500	D-3
				TP4501	E-3
				TP4502	D-3
				TP4503	E-3
				TP4504	D-4
				TP4505	D-4
				TP4506	D-4
				TP4507	E-3
				TP4508	D-4
				TP4512	E-4
				TP4800	F-3
				TP4801	F-3
				TP4802	F-3
				TP4803	F-3
				TP4804	F-3
				TP4805	F-3
				TP4806	F-3
				TP4807	F-3
				TP4808	F-3
				TP4809	F-3
				TP4810	F-3
				TP4811	F-3
				TP4821	H-2
				TP4822	I-2
				TP4825	H-2
				TP4826	H-2
				TP4827	H-2
				TP4828	I-2
				TP4829	I-2
				TP4830	H-2
				TP4831	H-1
				TP4832	I-1
				TP4835	I-2
				TP4836	H-2
				TP4837	H-2
				TP5400	D-6
				TP5500	E-6
				TP5510	E-6
				TP5600	H-4
				TP5601	H-4
				TP5602	H-4
				TP5603	B-1
				TP5604	B-1
				TP5605	B-1
				TP5606	B-1
				TP5607	B-1
				TP5608	B-1
				TP5660	F-4
				TP5700	E-5
				TP5701	I-2
				TP5702	H-2
				TP5705	A-4
				TP5706	D-5
				TP8037	F-4
				TP8301	B-5
				TP8401	H-5
				TP8402	H-6
				TP8403	H-6
				TP8404	H-5
				TP8501	F-4
				TP8745	F-6
				TP8801	H-1
				TP8802	H-1
				TP8803	H-1
				TP8804	H-1
				TP8805	H-1
				TP8806	H-1
				TP8807	H-1
				TP8808	H-1
				TP8851	F-4
				TP9000	G-3
				TP9010	G-1
				TPC0F	D-6
				TPEC0	B-6
				TPSON	B-6
				TPS0S	D-5
				TPS15V	B-6

TH-42PV8D/H/HM/M/MR/MS/MT  
A-BOARD PARTS LOCATION

**Parts Location**

A-BOARD (COMPONENT SIDE)					
IC		TRANSISTOR		TP	
IC1100	F-4	Q2027	E-5	TP4840	B-1
IC1101	F-4	Q2032	G-5	TP9011	A-1
IC1103	G-4	Q3000	F-2	TP9311	B-2
IC2010	G-4	Q3001	E-2	TP9312	B-2
IC2012	G-4	Q3002	G-3		
IC2013	F-3	Q3003	G-3		
IC2107	H-4	Q3004	G-3		
IC2108	G-5	Q3005	G-3		
IC2301	H-4	Q3009	G-3		
IC4510	E-4	Q3010	G-3		
IC4514	F-3	Q4514	D-3		
IC4515	F-3	Q4515	D-3		
IC4800	C-1	Q4516	D-4		
IC5660	D-4	Q4517	E-3		
IC8001	D-5	Q4811	B-2		
IC8002	D-3	Q5522	E-5		
IC8003	C-4	Q5600	B-4		
IC8403	B-5	Q5601	B-4		
IC8554	D-5	Q5602	B-4		
IC8601	F-4	Q5606	B-3		
IC9003	C-3	Q5607	B-3		
IC9303	E-2	Q8401	A-5		
IC9500	A-2	Q8402	B-5		
IC9802	A-3	Q8801	C-1		
IC9803	A-3	Q8802	C-1		
IC9900	D-2	Q8850	D-5		
IC9901	C-2	Q8851	E-5		
		Q9044	B-3		
		Q9046	B-3		
		Q9807	B-2		
		Q9808	B-2		
		Q9809	B-2		

TH-42PV8D/H/HM/M/MR/MS/MT  
A-BOARD PARTS LOCATION



**A-BOARD (COMPONENT SIDE)**  
**TZTNP01RWTM(D/H/HM/M/MR/MT) TZTNP01RWTQ(MS)**

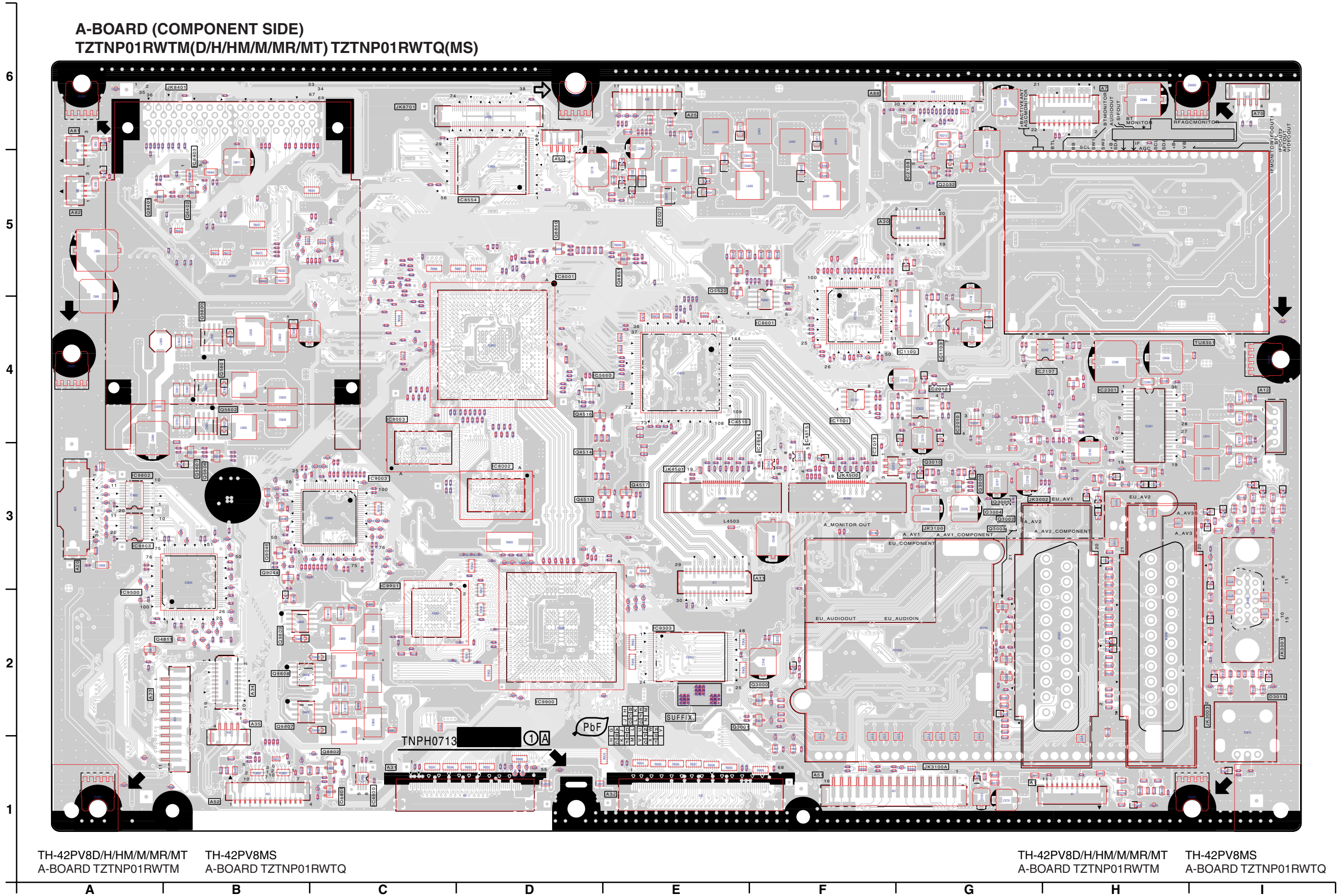

TH-42PV8D/H/HM/M/MR/MT  
 A-BOARD TZTNP01RWTM

TH-42PV8MS  
 A-BOARD TZTNP01RWTQ

TH-42PV8D/H/HM/M/MR/MT  
 A-BOARD TZTNP01RWTM

TH-42PV8MS  
 A-BOARD TZTNP01RWTQ

## 12.4. C1-Board

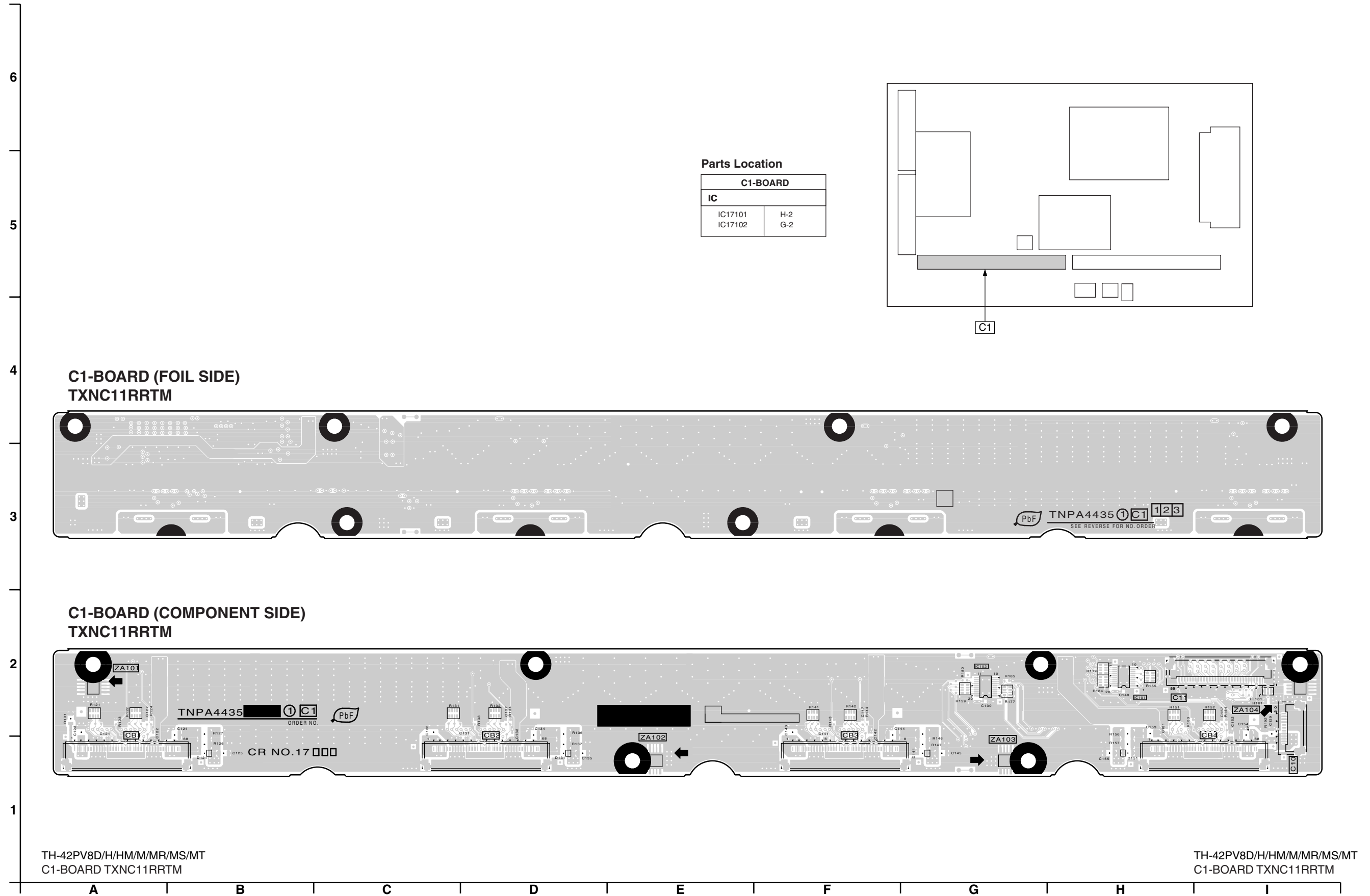

# 12.5. C2-Board

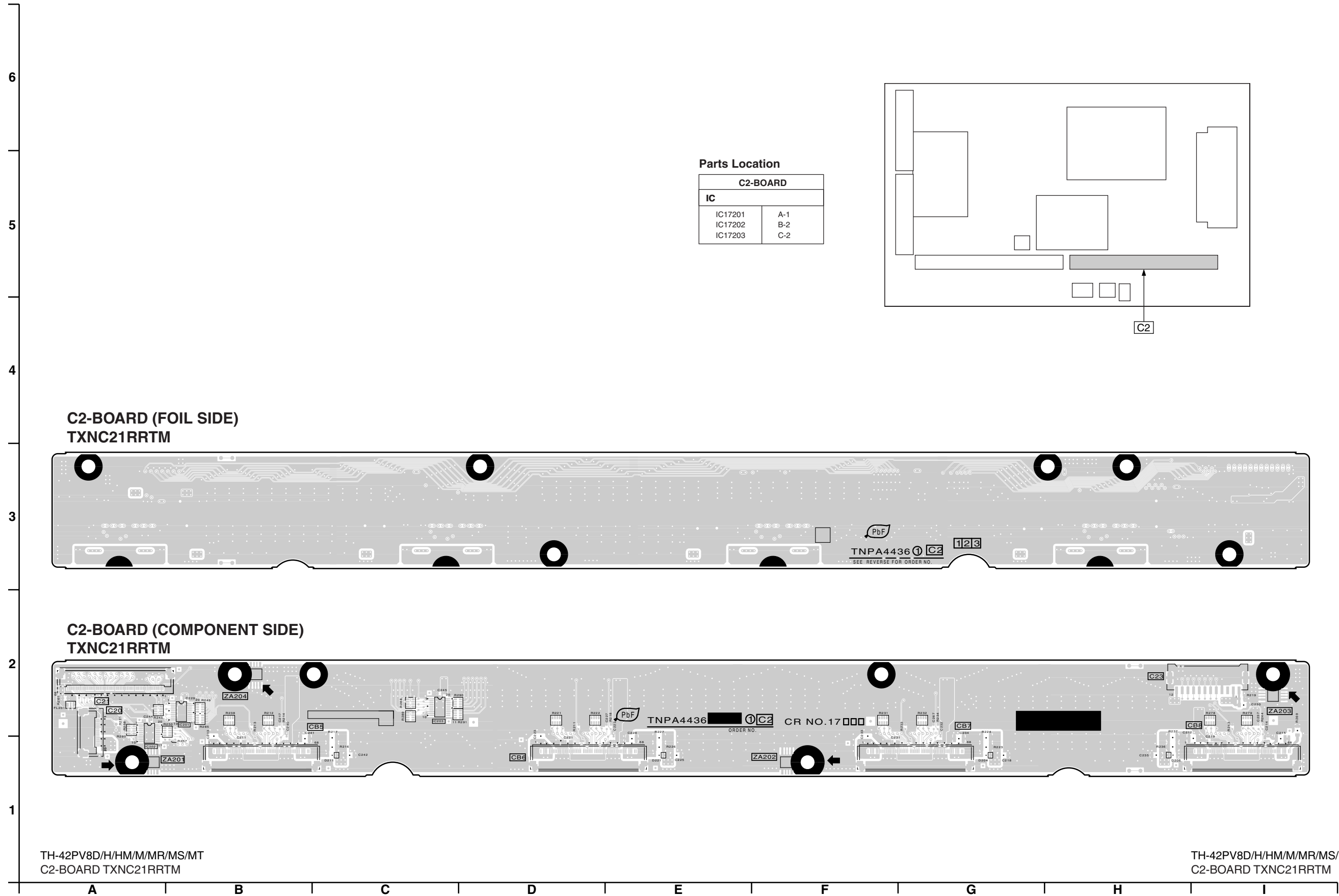

# 12.6. SC-Board

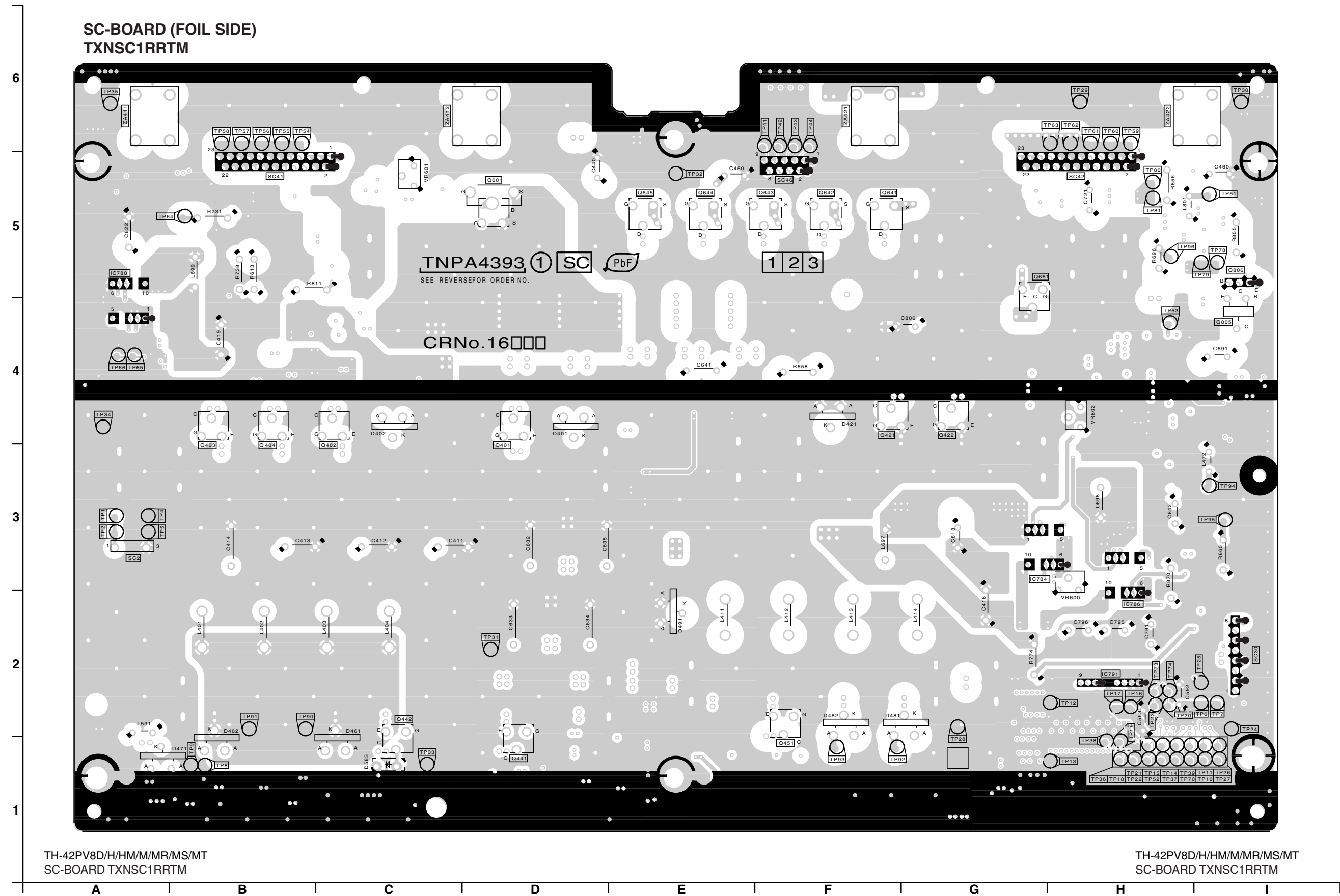



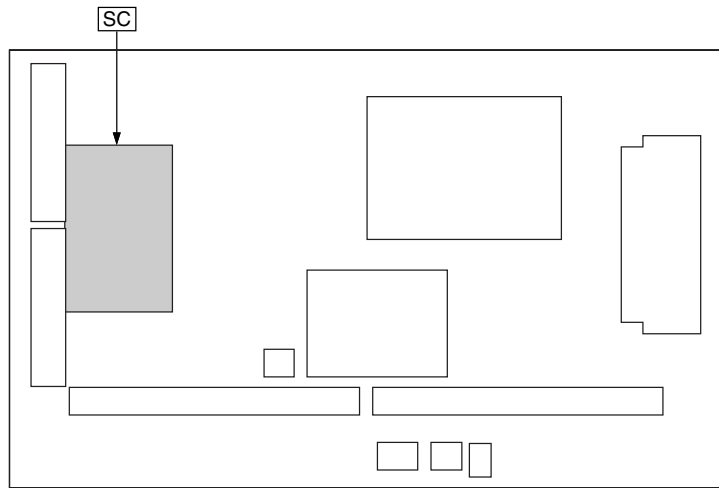

**Parts Location**

SC-BOARD (FOIL SIDE)							
IC		TEST POINT		TP41	F-6		
IC16784	G-3	TP1	A-3	TP42	F-6		
IC16786	H-2	TP2	A-3	TP43	F-6		
IC16788	A-5	TP4	A-3	TP44	F-6		
IC16791	H-2	TP5	A-3	TP51	I-5		
<b>TRANSISTOR</b>		TP6	I-2	TP52	H-1		
		TP7	I-2	TP53	H-4		
		TP8	B-1	TP54	B-6		
		TP9	B-1	TP55	B-6		
		Q16401	D-4	TP10	I-1	TP56	B-6
		Q16402	C-4	TP11	I-1	TP57	B-6
		Q16403	B-4	TP12	H-2	TP58	B-6
		Q16404	B-4	TP13	H-1	TP59	H-6
		Q16421	F-4	TP14	H-1	TP60	H-6
		Q16422	G-4	TP15	H-1	TP61	H-6
Q16441	D-1	TP16	H-2	TP62	H-6		
Q16442	C-2	TP17	H-2	TP63	H-6		
Q16451	F-2	TP18	H-1	TP64	B-5		
Q16601	D-5	TP19	H-1	TP65	A-4		
Q16641	F-5	TP20	H-2	TP66	A-4		
Q16642	F-5	TP21	H-1	TP70	H-1		
Q16643	F-5	TP22	H-1	TP73	H-2		
Q16644	E-5	TP23	H-2	TP74	H-2		
Q16645	E-5	TP24	I-2	TP78	I-5		
Q16661	G-5	TP25	I-2	TP79	I-5		
Q16805	I-4	TP26	I-1	TP80	H-5		
Q16806	I-5	TP27	I-1	TP81	H-5		
<b>VOLUME</b>		TP28	G-2	TP90	B-2		
		TP29	H-6	TP91	B-2		
		VR16600	H-3	TP92	F-1		
		VR16601	C-5	TP93	F-1		
		VR16602	H-4	TP30	I-6		
		TP31	D-2	TP94	I-3		
		TP32	E-5	TP95	I-3		
		TP33	C-1	TP96	H-5		
		TP34	A-4				
		TP35	A-6				
TP36	H-1						
TP37	H-1						
TP38	H-1						
TP39	H-1						

TH-42PV8D/H/HM/M/MR/MS/MT  
SC-BOARD PARTS LOCATION

**Parts Location**

SC-BOARD (COMPONENT SIDE)							
IC		PHOTO COUPLER		Q16621	F-4	TEST POINT	
IC16471	B-5	PC16480	A-4	Q16622	F-4	TP3	C-2
IC16472	A-4	PC16601	H-5	Q16623	F-4	TP46	B-2
IC16501	E-3	PC16602	H-5	Q16641	D-5	TP82	A-2
IC16521	E-1	PC16603	H-5	Q16642	D-5	TP97	H-5
IC16561	C-2	PC16705	B-4	Q16643	D-5	TPSC1	A-5
IC16562	C-1	PC16710	B-4	Q16644	E-5	TPSOS6	B-2
IC16581	H-1	PC16896	B-4	Q16645	E-5	TPSOS7	A-2
IC16724	B-5	PC16897	B-3	Q16661	C-5	TPVAD	A-3
IC16725	B-5			Q16662	B-4	TPVSCN	A-3
IC16752	G-4	<b>TRANSISTOR</b>		Q16663	C-4	TPVSET	I-5
IC16771	B-4	Q16401	F-4	Q16664	B-4	TPVSUS	I-2
IC16772	B-4	Q16402	G-4	Q16665	B-4		
IC16784	C-3	Q16403	H-4	Q16762	F-4	<b>VOLUME</b>	
IC16786	B-3	Q16404	H-4	Q16781	B-5	VR16600	B-3
IC16787	A-3	Q16421	D-4	Q16791	A-4	VR16601	G-5
IC16788	I-4	Q16422	C-4	Q16794	A-4	VR16602	B-4
IC16789	I-4	Q16441	F-1	Q16805	A-4		
IC16791	B-2	Q16442	G-1	Q16806	A-5		
		Q16451	D-2	Q16814	B-3		
		Q16471	A-5	Q16815	B-3		
		Q16501	E-4	Q16816	B-3		
		Q16521	E-4	Q16817	B-3		
		Q16531	F-1	Q16871	A-3		
		Q16532	F-1	Q16872	I-4		
		Q16551	E-1	Q16873	H-4		
		Q16552	E-1	Q16874	H-4		
		Q16581	H-1	Q16875	I-5		
		Q16601	F-5	Q16876	B-2		
		Q16602	G-5	Q16879	H-5		
		Q16603	G-5	Q16881	I-4		
		Q16604	H-5	Q16882	I-4		
		Q16605	H-5				
		Q16606	G-5				
		Q16607	G-6				
		Q16608	H-6				

TH-42PV8D/H/HM/M/MR/MS/MT  
SC-BOARD PARTS LOCATION

SC-BOARD (COMPONENT SIDE)  
TXNSC1RRTM

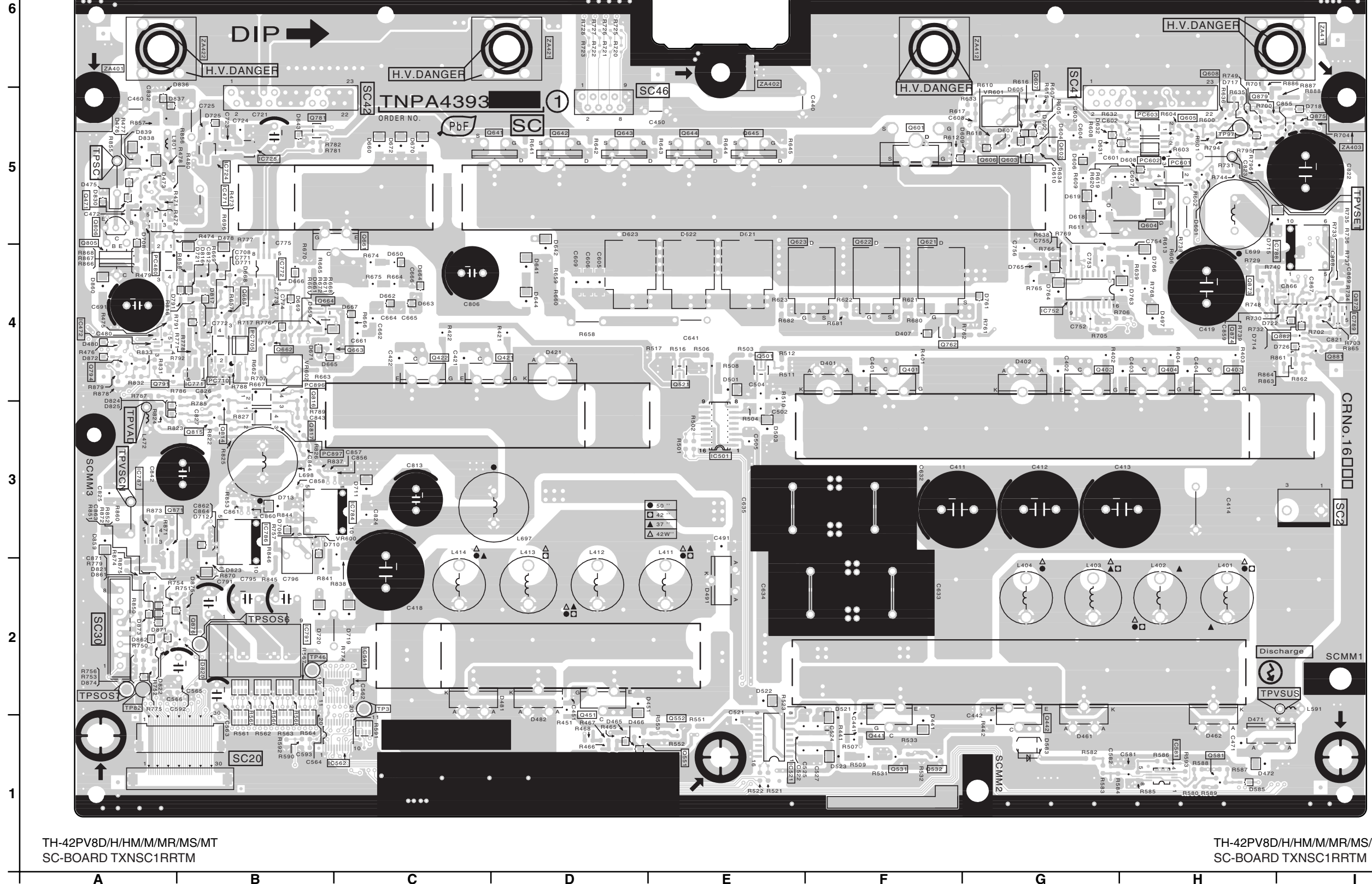

TH-42PV8D/H/HMM/MR/MS/MT  
SC-BOARD TXNSC1RRTM

TH-42PV8D/H/HMM/MR/MS/MT  
SC-BOARD TXNSC1RRTM

# 12.7. SU-Board

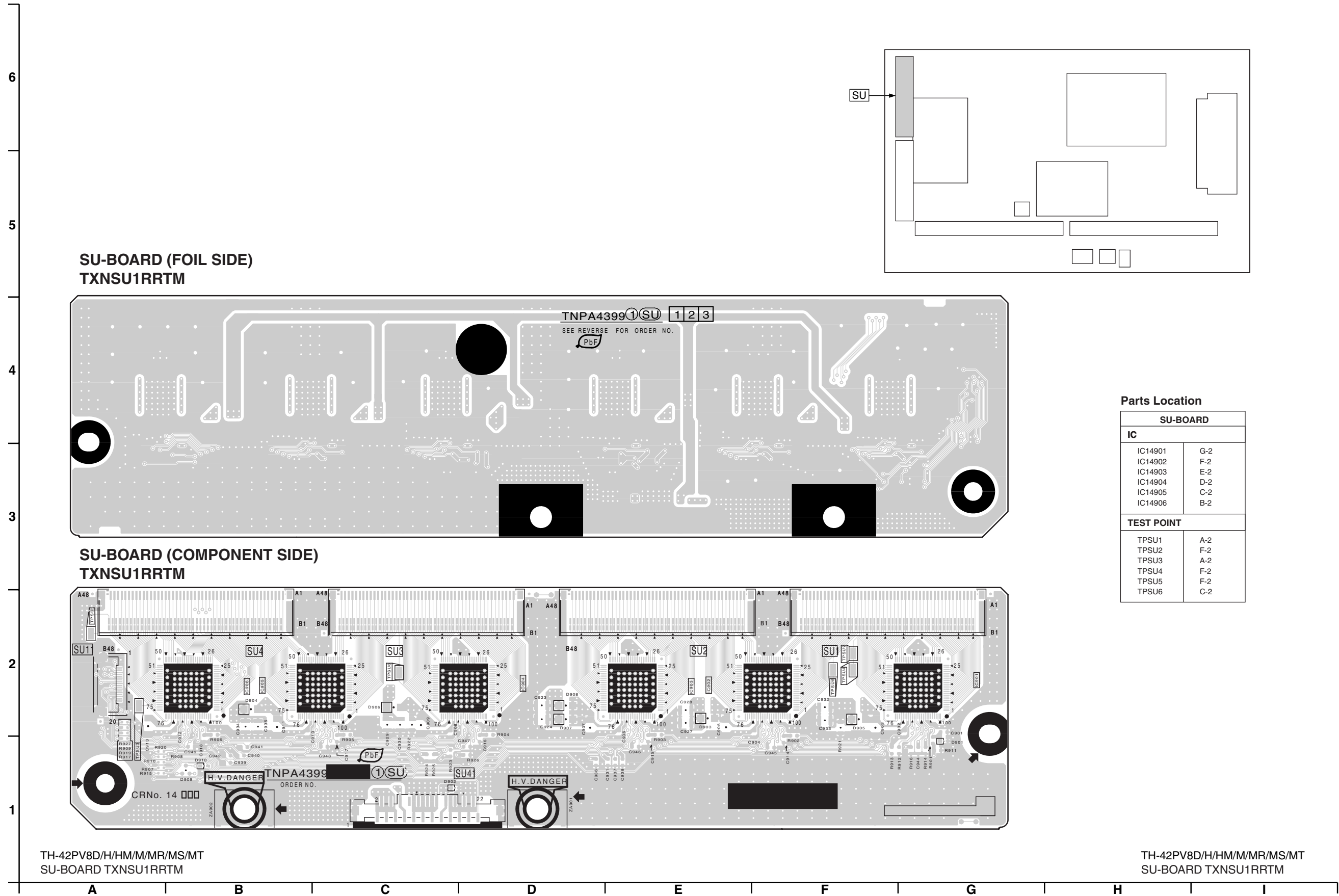

# 12.8. SD-Board

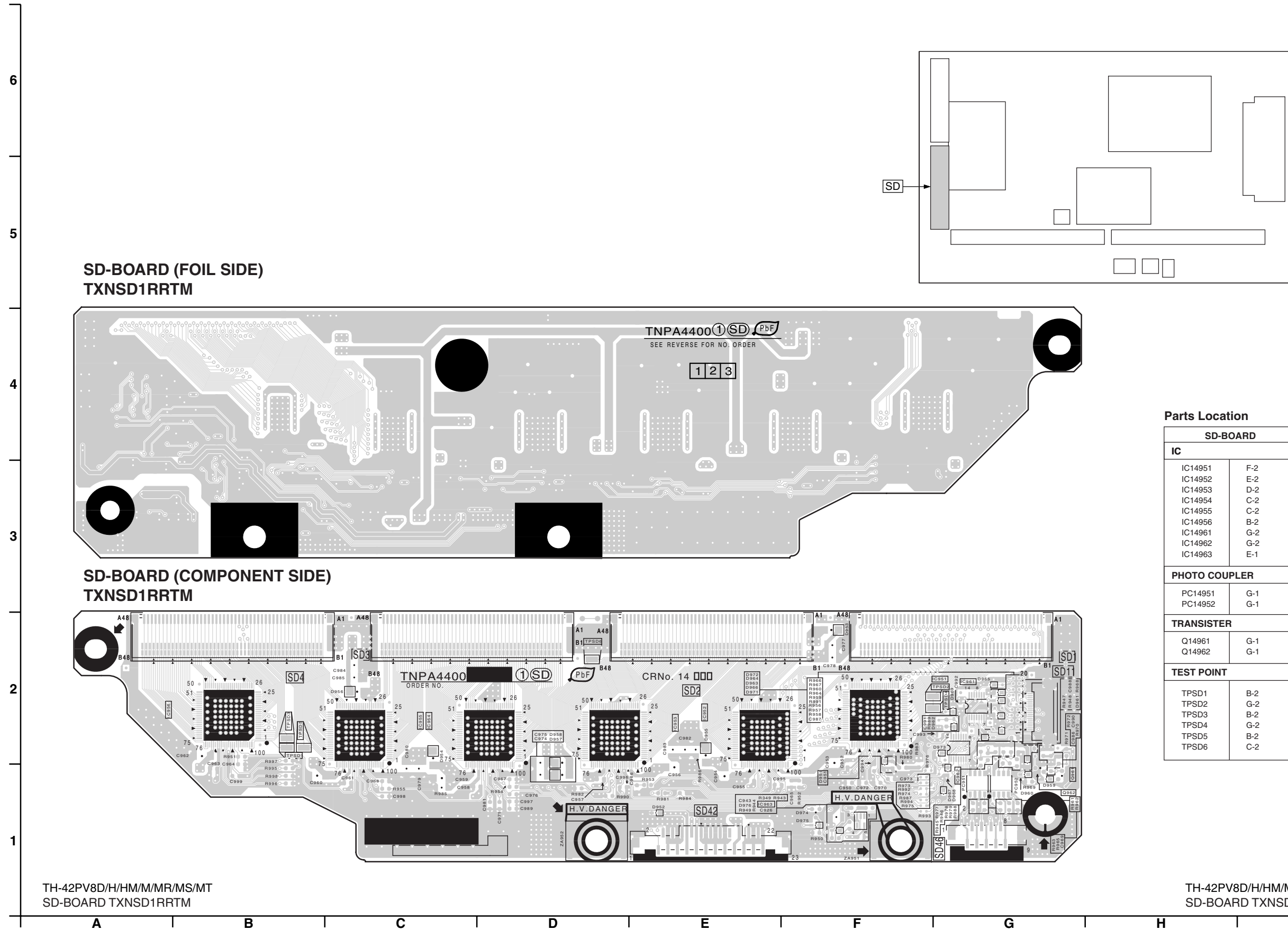

# 12.9. SS-Board

Parts Location

SS-BOARD (FOIL SIDE)							
IC		TEST POINT		TP25	I-2	TPSOS8	I-2
IC16301	G-3	TP2	G-4	TP26	I-2	TPSS1	G-1
<b>TRANSISTOR</b>		TP3	G-4	TP27	G-1	TPVDA	I-3
Q16001	E-2	TP4	G-4	TP28	I-2	TPVe	H-2
Q16002	E-2	TP5	H-4	TP29	C-1	TPVe2	H-2
Q16003	F-2	TP6	I-3	TP30	A-1	TPVSUS	F-3
Q16021	C-2	TP7	H-4	TP31	A-1	<b>VOLUME</b>	
Q16022	B-2	TP8	H-4	TP33	I-3	VR16000	H-3
Q16023	C-2	TP9	H-4	TP34	I-3		
Q16041	D-4	TP10	H-4	TP36	I-2		
Q16042	E-4	TP11	H-4	TP38	F-3		
Q16051	C-3	TP13	I-3	TP39	E-3		
Q16052	C-3	TP14	H-3	TP40	B-2		
Q16331	F-2	TP15	I-3	TP41	B-2		
Q16335	F-2	TP16	I-3	TP51	A-2		
		TP17	I-3	TP52	I-2		
		TP18	I-3	TP53	B-1		
		TP19	I-3	TP54	D-1		
		TP20	I-3	TP55	G-1		
		TP24	I-2	TP56	I-1		

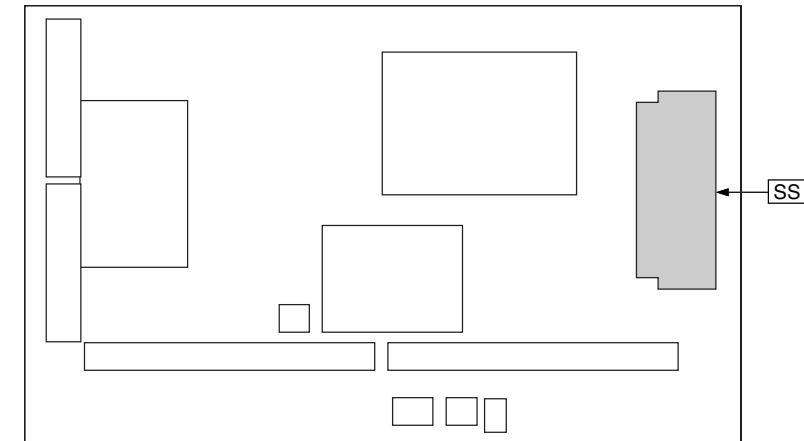

SS-BOARD (FOIL SIDE)  
TXNSS1RRTM

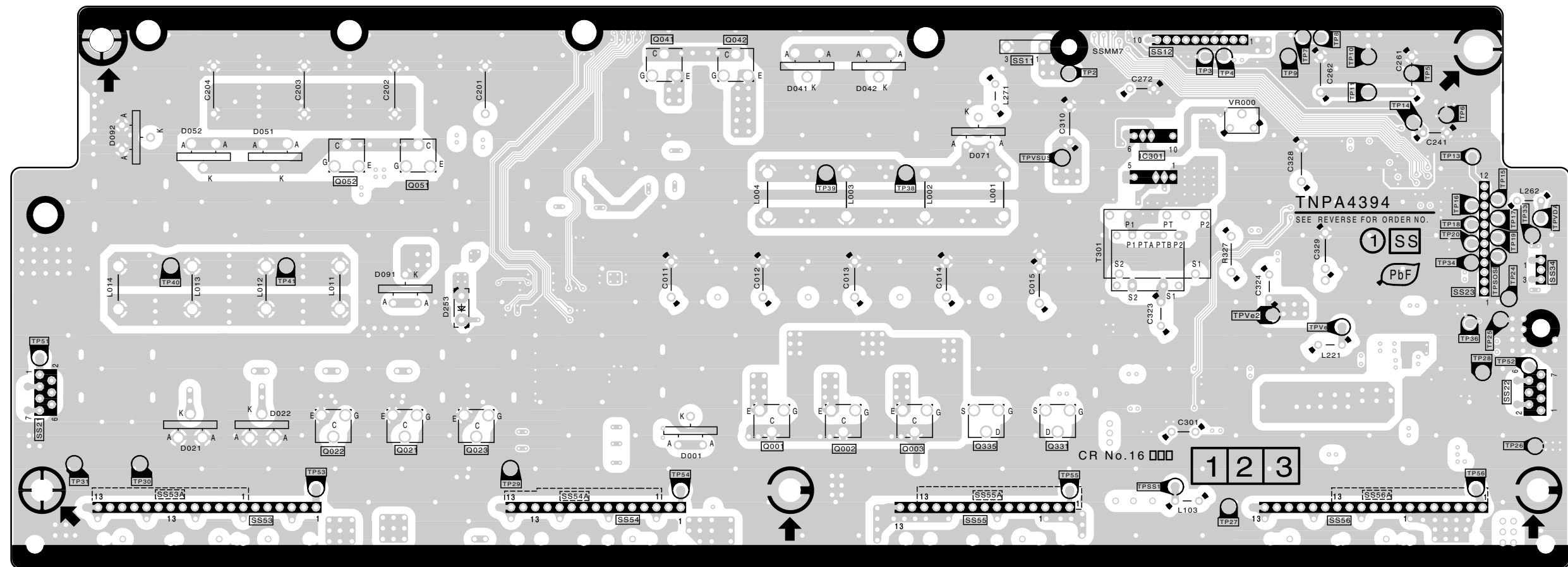

TH-42PV8D/H/HM/M/MR/MS/MT  
SS-BOARD TXNSS1RRTM

TH-42PV8D/H/HM/M/MR/MS/MT  
SS-BOARD TXNSS1RRTM

A B C D E F G H I



6  
5  
4  
3  
2  
1  
A B C D E F G H I

Parts Location

SS-BOARD (COMPONENT SIDE)					
IC	TRANSISTOR	Q16181	F-3	TEST POINT	
IC16131	F-2	Q16001	E-2	Q16181	F-3
IC16151	F-3	Q16002	E-2	Q16182	G-3
IC16191	B-3	Q16003	D-2	Q16191	B-2
IC16241	B-3	Q16021	G-2	Q16251	G-2
IC16251	F-2	Q16022	H-2	Q16280	A-2
IC16301	C-3	Q16023	G-2	Q16301	C-2
IC16302	C-2	Q16041	F-4	Q16302	C-2
IC16303	B-3	Q16042	E-4	Q16304	C-2
		Q16051	G-3	Q16304	C-2
		Q16052	H-3	Q16321	B-2
		Q16102	B-2	Q16331	C-2
		Q16104	B-2	Q16335	D-2
		Q16141	F-1	Q16339	B-2
		Q16161	F-2		
		Q16171	E-3		
		Q16172	F-3		
				VOLUME	
				VR16000	C-3

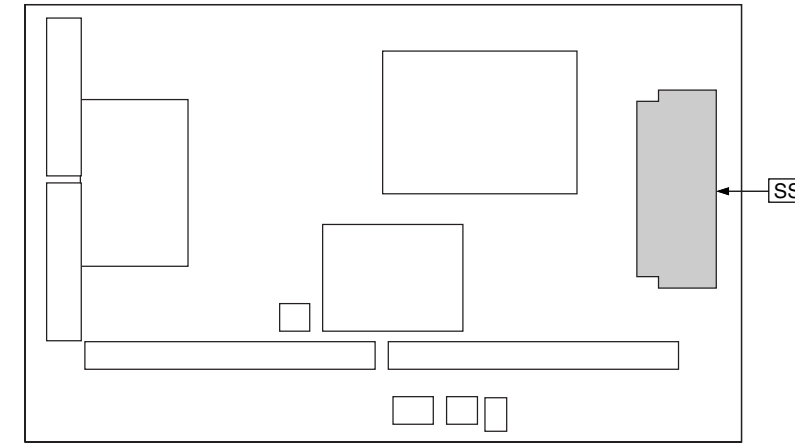

SS-BOARD (COMPONENT SIDE)  
TXNSS1RRTM

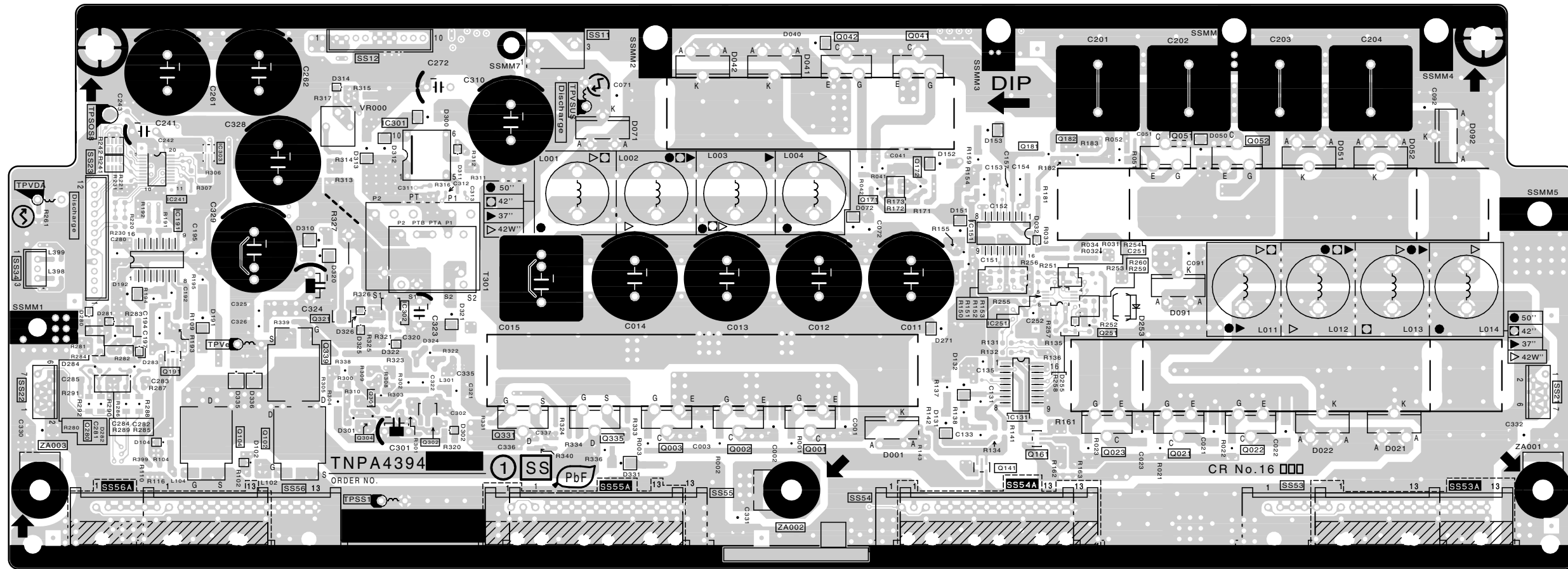

TH-42PV8D/H/HM/M/MR/MS/MT  
SS-BOARD TXNSS1RRTM

TH-42PV8D/H/HM/M/MR/MS/MT  
SS-BOARD TXNSS1RRTM

# 13 Exploded View and Replacement Parts List

## 13.1. Exploded View and Mechanical Replacement Parts List

### 13.1.1. Exploded View

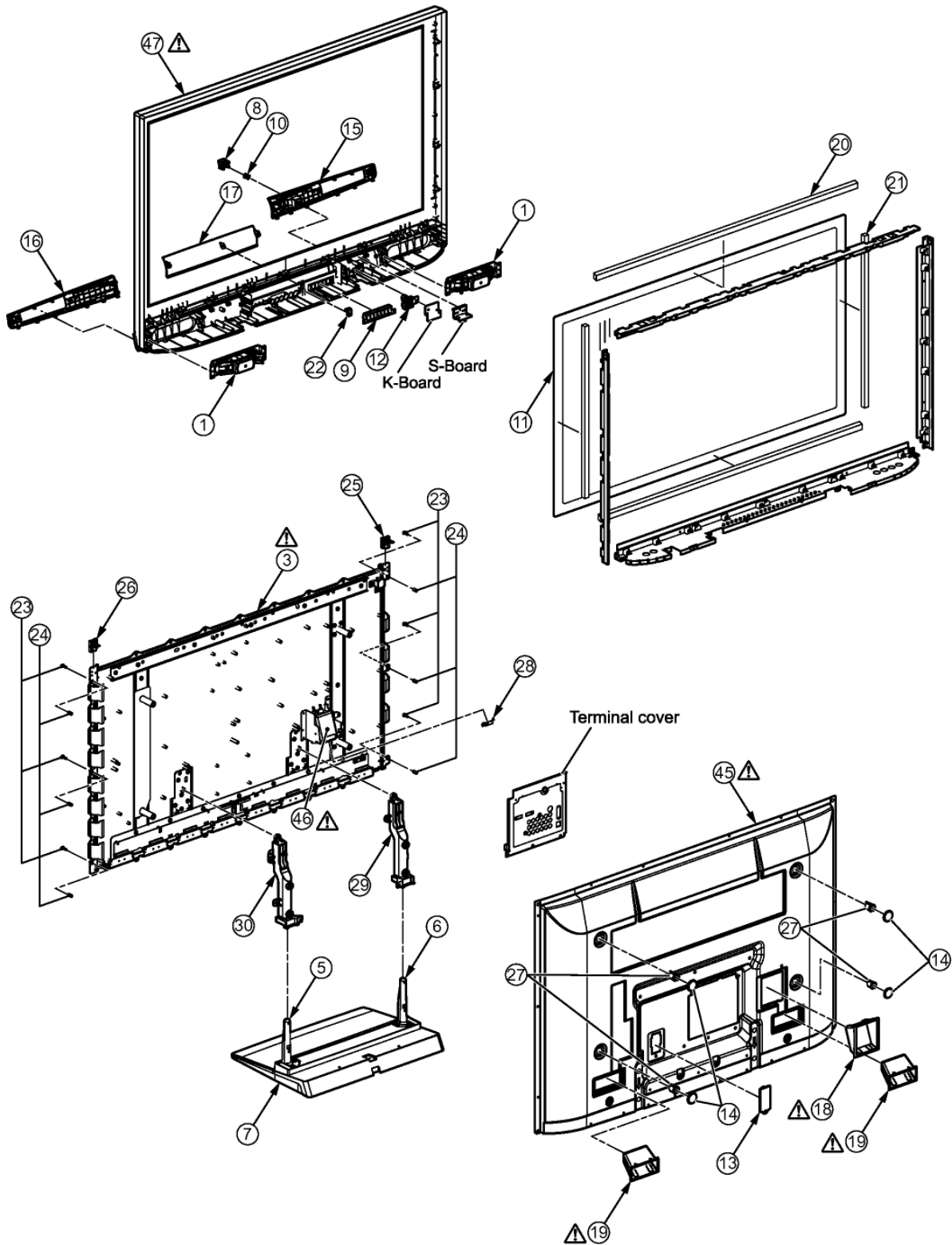

### 13.1.2. Packing

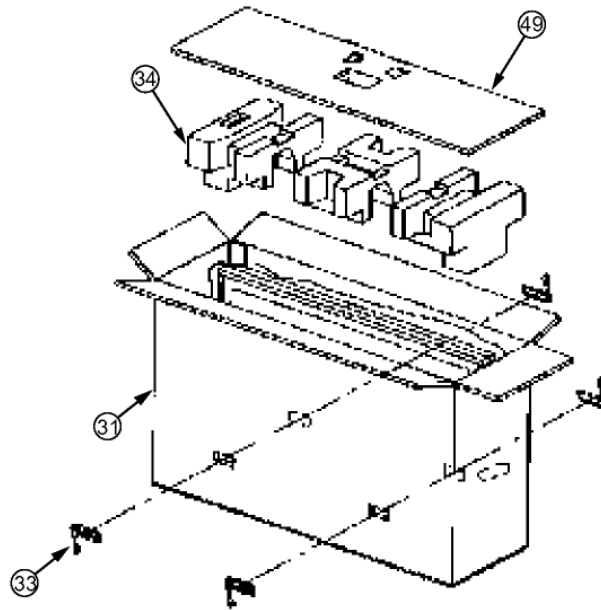
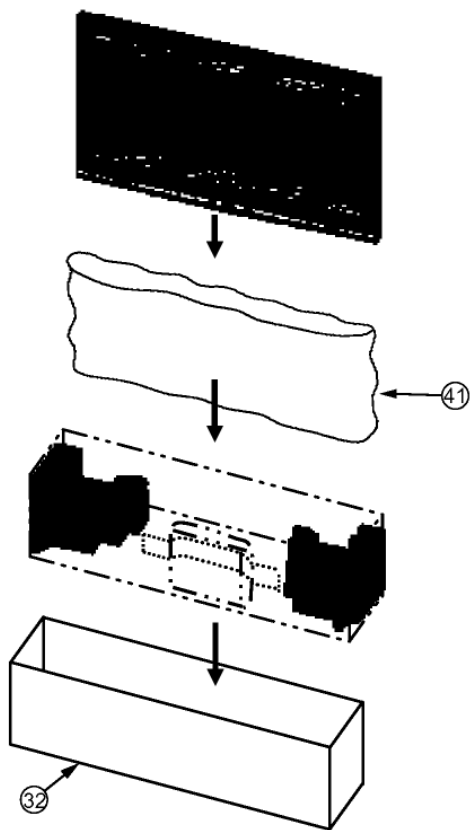

#### ACCESSORY

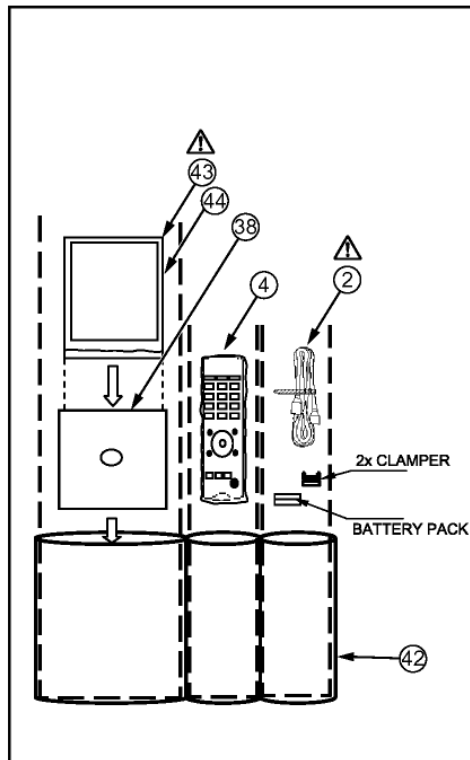

#### BACK SIDE VIEW

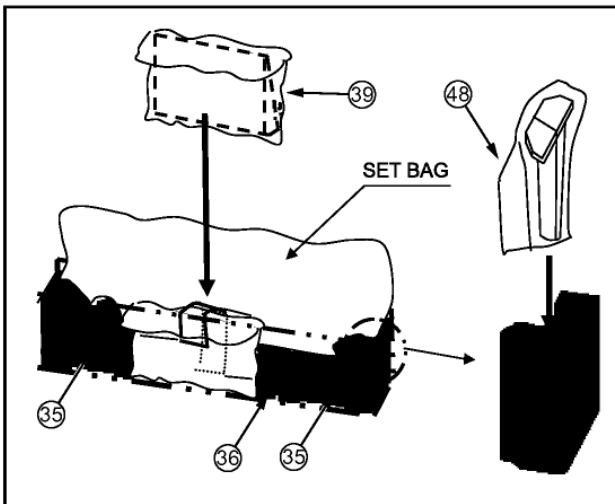









### 13.1.3. Mechanical Replacement Parts List

**Note: Important Safety Notice**







Components identified by  mark have special characteristics important for safety. When replacing any of these components, use only manufacturer's specified parts.

**Note:**

All parts except parts mentioned [PAVCSG] in the Remarks column are supplied by PAVC-CSG. Parts mentioned [PAVCSG] are supplied by PAVCSG.

Safety	Ref. No.	Part No.	Part Name & Description	Q'ty	Remarks
	1	EAS16S06A	SPEAKER	2	
	2	K2CN3DH00006	AC CORD	1	MR
	2	K2CT3DH00018	AC CORD	1	H/HM/M
	2	K2CT3DH00025	AC CORD	1	MS
	2	K2CZ3YY00004	AC CORD	1	MT
	3	MD42H11A1J	PLASMA DISPLAY PANEL	1	
	4	N2QAYB000227	REMOTE CONTROL	1	PAVCSG
	5	TBLA3652	STAND POLE RIGHT	1	PAVCSG
	6	TBLA3653	STAND POLE LEFT	1	PAVCSG
	7	TBLX0068	PEDESTAL STAND	1	PAVCSG
	8	TBXA53402	POWER BUTTON	1	PAVCSG
	9	TBXA53502	SELECTION BUTTON	1	PAVCSG
	10	TESD082	POWER BUTTON SPRING	1	PAVCSG
		THEJ016J	SCREW (AC INRET:2)	2	
		THEL0429	SCREW	14	
		THEL052Z	SCREW (BC TOP:4)	4	
		THEL063N	SCREW (STAND-TV)	4	PAVCSG
		THTF011N	SCREW	57	
	11	TKGA5426	FRONT GLASS	1	
	12	TKKC5313	LED PANEL	1	PAVCSG
	14	TKKL5387	M8 SPACER CAP	4	PAVCSG
	13	TKKL5438	ADJUSTMENT COVER	1	PAVCSG
	15	TKPB21202	SPEAKER PANEL LEFT	1	PAVCSG
	16	TKPB21302	SPEAKER PANEL RIGHT	1	PAVCSG
	17	TKPB21502	DOOR	1	PAVCSG
	18	TKPB23101	INLET COVER	1	PAVCSG
	19	TKRA65001	REAR COVER HANDLE	2	PAVCSG
	20	TMKG843	CUSHION (UPPER/BOTTOM) FOR FRONT GLASS	2	PAVCSG
	21	TMKG844	CUSHION (LEFT/RIGHT) FOR FRONT GLASS	2	PAVCSG
		TMM16473-1	CLAMPER	1	
		TMM17499	CLAMPER	1	
		TMM25401	CLAMPER	1	
		TMM6428-1	CLAMPER	1	
		TMME061	CLAMPER	2	
		TMME061	CLAMPER	2	
		TMME088	CLAMPER	2	
		TMME260	CLAMPER	1	
		TMME287	CLAMPER	9	
		TMME289	CLAMPER	2	
		TMME292	CLAMPER	10	
		TMME292	CLAMPER	1	
	22	TMMX186	DOOR SPRING	1	
	23	TMMX211	REAR COVER SPACER	6	PAVCSG

Safety	Ref. No.	Part No.	Part Name & Description	Q'ty	Remarks
	24	TMMX212	REAR COVER SPACER RING	6	PAVCSG
	25	TMMX214	REAR COVER HOOK LEFT	1	
	26	TMMX215	REAR COVER HOOK RIGHT	1	
	27	TMMX222	M8 SPACER	4	PAVCSG
		TMXX041	AC CORD CLAMPER	2	D/H/HM/M/MR/MS
	28	TMXX045	AC CORD HOLDER	1	
		TMXX048	AC CORD CLAMPER	2	MT
	29	TMZX5121	STAND BRACKET LEFT	1	PAVCSG
	30	TMZX5122	STAND BRACKET RIGHT	1	PAVCSG
	32	TPCC38801	CARTON BOX BOTTOM	1	PAVCSG
	31	TPCC38901	CARTON BOX TOP	1	PAVCSG M
	31	TPCC38901	CARTON BOX TOP	1	PAVCSG HM
	31	TPCC38902	CARTON BOX TOP	1	PAVCSG MR
	31	TPCC38903	CARTON BOX TOP	1	PAVCSG MT
	31	TPCC38904	CARTON BOX TOP	1	PAVCSG MS
	31	TPCC38905	CARTON BOX TOP	1	PAVCSG H
	31	TPCC38906	CARTON BOX TOP	1	PAVCSG D
	33	TPD169487	JOINT	4	
	34	TPDA1777	TOP CUSHION	1	PAVCSG
	35	TPDA1778	BOTTOM CUSHION	1	PAVCSG
	36	TPDA1873	PEDESTAL CUSHION	1	PAVCSG
	38	TPDF2178	ACCESSORY PAD	1	PAVCSG
	39	TPEB334	BAG (FOR STAND)	1	PAVCSG
		TPEB342	BAG (SCREW (STAND-TV) )	1	PAVCSG
	41	TPEH332	SET BAG	1	PAVCSG
	42	TPEP024	ACCESSORY BAG	1	PAVCSG
	43	TQBC2281	INSTRUCTION BOOK (ENGLISH)	1	PAVCSG D/H/HM/M/MR/MT/MS
	43	TQBC2282	INSTRUCTION BOOK (CHINESE))	1	PAVCSG D/H
	43	TQBC2283	INSTRUCTION BOOK (ARABIA)	1	PAVCSG M/MR/MS
	43	TQBC2284	INSTRUCTION BOOK (PERSIAN))	1	PAVCSG MR
	43	TQBC2285	INSTRUCTION BOOK (THAI))	1	PAVCSG MT
	43	TQBC2360	INSTRUCTION BOOK (ENGLISH)	1	PAVCSG HM
	43	TQBC2361	INSTRUCTION BOOK (CHINESE))	1	PAVCSG HM
	44	TQEF075	BAG (INSTRUCTION BOOK)	1	PAVCSG
		TQZH986	SCREW USE HANDBILL	1	PAVCSG
		TSXL519	CABLE (C10-C20/SU11-SD11)	2	
		TSXL664	CABLE (C11-A31)	1	
		TSXL665	CABLE (C21-A32)	1	
		TSXL674	CABLE (A20-SC20)	1	
	45	TTUA1853	REAR COVER	1	PAVCSG H
	45	TTUA1854	REAR COVER	1	PAVCSG MR
	45	TTUA1855	REAR COVER	1	PAVCSG MS
	45	TTUA1856	REAR COVER	1	PAVCSG MT

Safety	Ref. No.	Part No.	Part Name & Description	Q'ty	Remarks
	45	TTUA1858	REAR COVER	1	PAVCSG D
	45	TTUA1870	REAR COVER	1	PAVCSG M
	45	TTUA1966	REAR COVER	1	PAVCSG HM
	46	TXAJS01RRTH	INLET ASSY	1	PAVCSG D/H/HM/MT
	46	TXAJS01RRTM	INLET ASSY	1	PAVCSG M/MR/MS
	47	TXFKY01RWTM	CABINET ASSY	1	PAVCSG
		TXJA12RRTB	SPEAKER LEAD (A12-SP)	1	
		TXJSWRRRTB	SPEAKER LEAD (SP-SPR/L)	2	
		XSB3+6FJ	SCREW (LCD MTG)	2	
		XTB4+12GFJ	SCREW	41	
		XTB4+12GFJK	SCREW	10	
		XTB4+12GFN	TAP SCREW	4	
		XTS4+12GFN	SCREW	2	
		XTV3+10JFJK	SCREW	2	
		XTW3+10TFJ	SCREW	7	
		XYN3+F8FJ	SCREW	16	
		XYN3+J10FJ	SCREW	1	
		XYN3+J12FJ	SCREW	27	
		XYN3+J8FJ	SCREW	1	
		XYN4+E8FJ	SCREW	1	
		XYN4+F10FJ	SCREW	15	
		XYN4+F30FJK	SCREW (BC TOP6 SIDE6: AL	6	
		XYN5+C15FJ	SCREW	6	
		XYN5+F18FN	SCREW (STAND POLE)	4	
	48	XZB17X19C03	POLY BAG (STAND POLE)	1	

## 13.2. Electrical Replacement Parts List

### 13.2.1. Replacement Parts List Notes

#### Important Safety Notice

*Components identified by  $\triangle$  mark have special characteristics important for safety.  
When replacing any of these components, use only manufacturer's specified parts.*

#### RTL (Retention Time Limited)

**Note:** The marking (RTL) indicates that the Retention Time is Limited for this item. After the discontinuation of this assembly in production, the item will continue to be available for a specific period of time. The retention period of availability is dependant on the type of assembly, and in accordance with the laws governing part and product retention. After the end of this period, the assembly will no longer be available.

Abbreviation of part name and description

#### 1. Resistor

Example:

ERD25TJ104     $\underline{C}$  100KOHM,  $\underline{J}$ , 1/4W  
                   Type                    Allowance

#### 2. Capacitor

Example:

ECKF1H103ZF     $\underline{C}$  0.01UF,  $\underline{Z}$ , 50V  
   Type                    Allowance

Type	Allowance
C : Carbon	F : $\pm 1\%$
F : Fuse	G : $\pm 2\%$
M : Metal Oxide Metal Film	J : $\pm 5\%$
S : Solid	K : $\pm 10\%$
W : Wire Wound	M : $\pm 20\%$

Type	Allowance
C : Ceramic	C : $\pm 0.25\text{pF}$
E : Electrolytic	D : $\pm 0.5\text{pF}$
P : Polyester	F : $\pm 1\text{pF}$
Polyprop	G : $\pm 3\text{pF}$
lene	J : $\pm 5\text{pF}$
T : Tantalum	K : $\pm 10\text{pF}$
	L : $\pm 15\text{pF}$
	M : $\pm 20\text{pF}$
	P : +100%, -0%
	Z : +80%, -20%

### 13.2.2. Electrical Replacement Parts List

**Note:** All parts except parts mentioned [PAVCSG] in the Remarks column are supplied by PAVC-CSG.  
Parts mentioned [PAVCSG] are supplied by PAVCSG.

Safety	Ref. No.	Part No.	Part Name & Description	Pcs	Remarks
	A1	K1KA11A00178	11P CONNECTOR	1	
	A7	K1KY22A00003	22P CONNECTOR	1	
	A12	K1KA04AA0190	4P CONNECTOR	1	
	A20	K1KY30BA0090	30P CONNECTOR	1	
	A25	K1KA11A00178	11P CONNECTOR	1	
	A31	K1MN55BA0266	55P CONNECTOR	1	
	A32	K1MN68BA0266	68P CONNECTOR	1	
	A33	K1KA11AA0715	11P CONNECTOR	1	
	A34	K1KA20AA0009	20P CONNECTOR	1	
	A35	K1KA04AA0104	4P CONNECTOR	1	
	A51	K1KA16AA0729	16P CONNECTOR	1	
	A52	K1KA14A00248	14P CONNECTOR	1	
	C10	K1MN20BA0231	20P CONNECTOR	1	
	C11	K1MN55BA0266	55P CONNECTOR	1	
	C20	K1MN20BA0266	20P CONNECTOR	1	
	C21	K1MN68BA0266	68P CONNECTOR	1	
	C23	K1KA12BA0107	12P CONNECTOR	1	
	C1102	FLJ1A106A043	C 0.010UF, K, 10V	1	
	C1103	FIG1C104A116	C 0.10UF, K, 16V	1	
	C1104	FIG1C104A116	C 0.10UF, K, 16V	1	
	C1106	FIH1H270A971	C 27UF, 50V	1	
	C1107	FIG1H220A731	C 22UF, 50V	1	
	C1108	FIG1C104A116	C 0.10UF, K, 16V	1	
	C1109	FIH1A1050032	C 10UF, 50V	1	
	C1111	FIH1A1050032	C 10UF, 50V	1	
	C1112	FIG1C104A116	C 0.10UF, K, 16V	1	
	C1114	FIG1C104A116	C 0.10UF, K, 16V	1	
	C1117	FIG1C104A116	C 0.10UF, K, 16V	1	
	C1122	FIG1E103A123	C 0.010UF, K, 16V	1	
	C1123	FIH1A1050032	C 10UF, 50V	1	
	C1127	FIG1C104A116	C 0.10UF, K, 16V	1	
	C1129	FIG1H101A565	C 100PF, K, 50V	1	
	C1131	FIG1H101A565	C 100PF, K, 50V	1	
	C1133	FIG1H1020008	C 1000UF, 50V	1	
	C1136	FIG1H1020008	C 1000UF, 50V	1	
	C1138	FIG1H560A731	C 56UF, 50V	1	
	C2023	FIG1C104A116	C 0.10UF, K, 16V	1	
	C2048	FIG1C104A116	C 0.10UF, K, 16V	1	
	C2049	FIG1C104A116	C 0.10UF, K, 16V	1	
	C2050	FIG1C104A116	C 0.10UF, K, 16V	1	
	C2052	FIG1C104A116	C 0.10UF, K, 16V	1	
	C2053	FIG1C104A116	C 0.10UF, K, 16V	1	
	C2054	FLJ1A106A043	C 0.010UF, K, 10V	1	
	C2055	FIG1H150A731	C 15UF, 50V	1	
	C2056	FIG1H180A731	C 18UF, 50V	1	
	C2057	FIG1C104A116	C 0.10UF, K, 16V	1	
	C2058	FIG1C104A116	C 0.10UF, K, 16V	1	
	C2059	FLJ1A106A043	C 0.010UF, K, 10V	1	
	C2091	FIG1H150A731	C 15UF, 50V	1	
	C2092	FIG1H220A731	C 22UF, 50V	1	
	C2096	FIG1C104A116	C 0.10UF, K, 16V	1	
	C2098	F2G0J2210013	E 220UF 6.3V	1	
	C2099	F2G0J2210013	E 220UF 6.3V	1	
	C2100	FIG1C104A116	C 0.10UF, K, 16V	1	
	C2101	FLJ1A106A043	C 0.010UF, K, 10V	1	
	C2102	FIG1C104A116	C 0.10UF, K, 16V	1	
	C2105	FIG1C104A116	C 0.10UF, K, 16V	1	

Safety	Ref. No.	Part No.	Part Name & Description	Pcs	Remarks
	C2106	FIG1C104A116	C 0.10UF, K, 16V	1	
	C2107	F2G0J470A019	E 47UF 6.3V	1	
	C2108	F2G0J470A019	E 47UF 6.3V	1	
	C2109	FIG1C104A116	C 0.10UF, K, 16V	1	
	C2110	FIG1C104A116	C 0.10UF, K, 16V	1	
	C2111	FIH0J2250008	C 2.2UF, K, 16V	1	
	C2112	FLJ1A106A043	C 0.010UF, K, 10V	1	
	C2113	FLJ1A106A043	C 0.010UF, K, 10V	1	
	C2114	FIG1C104A116	C 0.10UF, K, 16V	1	
	C2115	FIG1C104A116	C 0.10UF, K, 16V	1	
	C2116	FIG1H471A731	C 470UF, 50V	1	
	C2117	FIG1C104A116	C 0.10UF, K, 16V	1	
	C2118	FIH1A1050032	C 10UF, 50V	1	
	C2119	EEH1B1A221P	C 220PF, J, 10V	1	
	C2120	FIG1H560A731	C 56UF, 50V	1	
	C2121	FIG1H560A731	C 56UF, 50V	1	
	C2124	FIG1C104A116	C 0.10UF, K, 16V	1	
	C2125	FIG1E103A123	C 0.010UF, K, 16V	1	
	C2126	FLJ1A106A043	C 0.010UF, K, 10V	1	
	C2127	FIG1E103A123	C 0.010UF, K, 16V	1	
	C2128	FIG1E103A123	C 0.010UF, K, 16V	1	
	C2129	FIG1E103A123	C 0.010UF, K, 16V	1	
	C2135	FIG1E103A123	C 0.010UF, K, 16V	1	
	C2136	FIG1E103A123	C 0.010UF, K, 16V	1	
	C2137	FLJ1A106A043	C 0.010UF, K, 10V	1	
	C2138	FIG1C104A116	C 0.10UF, K, 16V	1	
	C2151	FLJ1A106A043	C 0.010UF, K, 10V	1	
	C2174	FIH1A1050032	C 10UF, 50V	1	
	C2175	F2G0J470A019	E 47UF 6.3V	1	
	C2176	FIG1E103A123	C 0.010UF, K, 16V	1	
	C2179	F2G0J470A019	E 47UF 6.3V	1	
	C2180	FIH1A1050032	C 10UF, 50V	1	
	C2184	FIG1H102A730	C 1000UF, 50V	1	
	C2187	FIH0J2250008	C 2.2UF, K, 16V	1	
	C2188	FIG1H471A730	C 470UF, 50V	1	
	C2189	FIH1A1050032	C 10UF, 50V	1	
	C2191	FLJ1A106A043	C 0.010UF, K, 10V	1	
	C2192	F2G0J470A019	E 47UF 6.3V	1	
	C2195	FIG1H102A730	C 1000UF, 50V	1	
	C2197	FIH1E333A129	C 0.033UF, 25V	1	
	C2198	FIH1E333A129	C 0.033UF, 25V	1	
	C2201	FIG1A473A053	C 0.47UF, 10V	1	
	C2202	FIH0J2250008	C 2.2UF, K, 16V	1	
	C2203	FIH1A1050032	C 10UF, 50V	1	
	C2204	FIH1A1050032	C 10UF, 50V	1	
	C2213	FIG1H102A730	C 1000UF, 50V	1	
	C2216	FIG1C104A116	C 0.10UF, K, 16V	1	
	C2244	FIG1C104A116	C 0.10UF, K, 16V	1	
	C2245	FIG1H102A730	C 1000UF, 50V	1	
	C2246	FLJ1A106A043	C 0.010UF, K, 10V	1	
	C2251	FLJ1A106A043	C 0.010UF, K, 10V	1	
	C2261	DOGDR00Z0002	M 0 OHM, 1/10W	1	
	C2262	DOGDR00Z0002	M 0 OHM, 1/10W	1	

Safety	Ref. No.	Part No.	Part Name & Description	Pcs	Remarks
	C2263	F1J1A106A043	C 0.010UF, K, 10V	1	
	C2264	F1J1A106A043	C 0.010UF, K, 10V	1	
	C2265	F1G1H101A731	C 100PF, K, 50V	1	
	C2266	F1G1H101A731	C 100PF, K, 50V	1	
	C2301	F1G1C104A116	C 0.10UF, K, 16V	1	
	C2302	F1G1C104A116	C 0.10UF, K, 16V	1	
	C2303	F1J1E105A171	C 1 UF 25V	1	
	C2305	F1J1E105A171	C 1 UF 25V	1	
	C2307	F1J1E105A171	C 1 UF 25V	1	
	C2313	F1H1A1050032	C 10UF, 50V	1	
	C2317	ECJ1VB1H104K	C 0.1UF, K, 50V	1	
	C2319	ECJ1VB1H104K	C 0.1UF, K, 50V	1	
	C2321	ECJ1VB1H104K	C 0.1UF, K, 50V	1	
	C2323	ECJ1VB1H104K	C 0.1UF, K, 50V	1	
	C2333	F1J1E3340003	C 0.33UF, Z, 25V	1	
	C2335	F1J1E3340003	C 0.33UF, Z, 25V	1	
	C2337	F1H1H223A970	C 0.22UF, K, 50V	1	
	C2339	F1H1H223A970	C 0.22UF, K, 50V	1	
	C2341	F1J1E3340003	C 0.33UF, Z, 25V	1	
	C2343	F1J1E3340003	C 0.33UF, Z, 25V	1	
	C2345	F1H1H223A970	C 0.22UF, K, 50V	1	
	C2347	F1H1H223A970	C 0.22UF, K, 50V	1	
	C2353	F1G1H102A730	C 1000UF, 50V	1	
	C2361	F2G1E4710007	E 470UF, 25V	1	
	C2362	ECJ3YB1E106M	C 10 UF, K, 25V	1	
	C2375	F1H1H223A970	C 0.22UF, K, 50V	1	
	C2377	F1H1H223A970	C 0.22UF, K, 50V	1	
	C2379	F1H1H223A970	C 0.22UF, K, 50V	1	
	C2381	F1H1H223A970	C 0.22UF, K, 50V	1	
	C2383	F1G1H102A730	C 1000UF, 50V	1	
	C2385	F1G1H102A730	C 1000UF, 50V	1	
	C2387	F1G1H102A730	C 1000UF, 50V	1	
	C2389	F1G1H102A730	C 1000UF, 50V	1	
	C2393	F1K1C1060004	C 0.010UF, 16V	1	
	C2394	F1J1H474A757	C 0.47UF, 50V	1	
	C2395	F1J1H474A757	C 0.47UF, 50V	1	
	C2399	F2G0J470A019	E 47UF 6.3V	1	
	C2400	F1G1C104A116	C 0.10UF, K, 16V	1	
	C2401	F1G1H181A731	C 180UF, 50V	1	
	C2402	F1G1C104A116	C 0.10UF, K, 16V	1	
	C2403	F2G1V220A020	E 22UF, 35V	1	
	C2404	F1G1H102A730	C 1000UF, 50V	1	
	C2407	F2H0J1010009	C 100UF, 6.3V	1	
	C2408	F1G1C104A116	C 0.10UF, K, 16V	1	
	C2409	F2G0J1020022	E 1100PF, J, 6.3V	1	
	C2410	F1H0J2250008	C 2.2UF, K, 16V	1	
	C2411	ECJ1VB1H104K	C 0.1UF, K, 50V	1	
	C2412	F2G1H100A031	E 10UF, 50V	1	
	C2413	F1H1A1050032	C 10UF, 50V	1	
	C2414	F1G1C104A116	C 0.10UF, K, 16V	1	
	C2415	F1G1C104A116	C 0.10UF, K, 16V	1	
	C2416	F1H1H330A971	C 33UF, 50V	1	
	C2417	F1H1H330A971	C 33UF, 50V	1	
	C2418	F1G1E103A123	C 0.010UF, K, 16V	1	
	C2419	F1G1H101A731	C 100PF, K, 50V	1	
	C2420	F1G1C104A116	C 0.10UF, K, 16V	1	
	C2427	F1H1A1050032	C 10UF, 50V	1	
	C2512	F1J1A106A043	C 0.010UF, K, 10V	1	
	C2515	F1H1H103A970	C 0.001UF, K, 50V	1	
	C2521	F1H1H103A970	C 0.001UF, K, 50V	1	
	C2522	ECJ1VB1H102K	C 1000PF, K, 50V	1	
	C2523	ECJ1VB1H102K	C 1000PF, K, 50V	1	
	C2524	ECJ1VB1H102K	C 1000PF, K, 50V	1	
	C2525	ECJ1VB1H102K	C 1000PF, K, 50V	1	
	C2526	ECJ1VB1H102K	C 1000PF, K, 50V	1	
	C2527	ECJ1VB1H102K	C 1000PF, K, 50V	1	
	C3002	F1H1H561A971	C 560UF, 50V	1	

Safety	Ref. No.	Part No.	Part Name & Description	Pcs	Remarks
	C3003	F1H1H561A971	C 560UF, 50V	1	
	C3007	F1H1H561A971	C 560UF, 50V	1	
	C3008	F1H1H561A971	C 560UF, 50V	1	
	C3010	F1H1H561A971	C 560UF, 50V	1	
	C3011	F1H1H561A971	C 560UF, 50V	1	
	C3013	F1H1H561A971	C 560UF, 50V	1	
	C3014	F1H1H561A971	C 560UF, 50V	1	
	C3022	F1H1A1050032	C 10UF, 50V	1	
	C3024	F1H1A1050032	C 10UF, 50V	1	
	C3025	F1H1A1050032	C 10UF, 50V	1	
	C3026	F1H1A1050032	C 10UF, 50V	1	
	C3039	F1H1A1050032	C 10UF, 50V	1	
	C3041	F1H1A1050032	C 10UF, 50V	1	
	C3043	F1H1A1050032	C 10UF, 50V	1	
	C3044	F1H1A1050032	C 10UF, 50V	1	
	C3046	F1H1A1050032	C 10UF, 50V	1	
	C3047	F1H1A1050032	C 10UF, 50V	1	
	C3048	F1H1A1050032	C 10UF, 50V	1	
	C3049	F1H1A1050032	C 10UF, 50V	1	
	C3070	F1J1A106A043	C 0.010UF, K, 10V	1	
	C3071	F1J1A106A043	C 0.010UF, K, 10V	1	
	C3072	F1G1C104A116	C 0.10UF, K, 16V	1	
	C3073	F1J1A106A043	C 0.010UF, K, 10V	1	
	C3074	F1J1A106A043	C 0.010UF, K, 10V	1	
	C3075	F1H1A1050032	C 10UF, 50V	1	
	C3077	F1G1C104A116	C 0.10UF, K, 16V	1	
	C3078	F1J1A106A043	C 0.010UF, K, 10V	1	
	C3083	F1J1A106A043	C 0.010UF, K, 10V	1	
	C3084	F1J1A106A043	C 0.010UF, K, 10V	1	
	C3085	F1J1A106A043	C 0.010UF, K, 10V	1	
	C3086	F1J1A106A043	C 0.010UF, K, 10V	1	
	C3088	F1J1A106A043	C 0.010UF, K, 10V	1	
	C3090	F1J1A106A043	C 0.010UF, K, 10V	1	
	C3091	F1J1A106A043	C 0.010UF, K, 10V	1	
	C3092	F1J1A106A043	C 0.010UF, K, 10V	1	
	C3093	F1J1A106A043	C 0.010UF, K, 10V	1	
	C3095	F2G1C1010034	E 100PF, J, 16V	1	
	C3098	ECJ1VB1C105K	C 0.01UF, K, 16V	1	
	C3103	F2G1C470A022	E 47UF, 16V	1	
	C3107	F1J1A106A043	C 0.010UF, K, 10V	1	
	C3108	F1J1A106A043	C 0.010UF, K, 10V	1	
	C3109	F1J1A106A043	C 0.010UF, K, 10V	1	
	C3114	F1J1A106A043	C 0.010UF, K, 10V	1	
	C3115	F1J1A106A043	C 0.010UF, K, 10V	1	
	C3116	F1J1A106A043	C 0.010UF, K, 10V	1	
	C3117	F1J1A106A043	C 0.010UF, K, 10V	1	
	C3139	F1G1C104A116	C 0.10UF, K, 16V	1	
	C3140	F1G1C104A116	C 0.10UF, K, 16V	1	
	C3141	F1G1C104A116	C 0.10UF, K, 16V	1	
	C3143	F1G1C104A116	C 0.10UF, K, 16V	1	
	C3144	F1J1A106A043	C 0.010UF, K, 10V	1	
	C3145	F1G1C104A116	C 0.10UF, K, 16V	1	
	C3146	F1J1A106A043	C 0.010UF, K, 10V	1	
	C3147	F1J1A106A043	C 0.010UF, K, 10V	1	

Safety	Ref. No.	Part No.	Part Name & Description	Pcs	Remarks
	C3701	ECJ2XC1H561K	C 560PF, K, 50V	1	
	C3703	ECJ2XC1H561K	C 560PF, K, 50V	1	
	C3711	ECJ2VF1H333Z	C 0.033UF, Z, 50V	1	
	C3712	ECJ2VF1H333Z	C 0.033UF, Z, 50V	1	
	C3750	FLJ1H102A721	C 1000UF, 50V	1	
	C4500	FIG1C104A116	C 0.10UF, K, 16V	1	
	C4501	FIG1C104A116	C 0.10UF, K, 16V	1	
	C4502	FIG1C104A116	C 0.10UF, K, 16V	1	
	C4503	FIG1C104A116	C 0.10UF, K, 16V	1	
	C4510	FIG1C104A116	C 0.10UF, K, 16V	1	
	C4511	FIG1C104A116	C 0.10UF, K, 16V	1	
	C4533	FIG1H680A731	C 68UF, 50V	1	
	C4534	FIG1C104A116	C 0.10UF, K, 16V	1	
	C4535	FIG1C104A116	C 0.10UF, K, 16V	1	
	C4547	FIG1C104A116	C 0.10UF, K, 16V	1	
	C4548	FIG1C104A116	C 0.10UF, K, 16V	1	
	C4549	FIG1C104A116	C 0.10UF, K, 16V	1	
	C4550	FIG1C104A116	C 0.10UF, K, 16V	1	
	C4551	FIG1C104A116	C 0.10UF, K, 16V	1	
	C4552	FIG1C104A116	C 0.10UF, K, 16V	1	
	C4553	FIG1H102A730	C 1000UF, 50V	1	
	C4554	F2G1C470A022	E 47UF, 16V	1	
	C4555	FLJ1A106A043	C 0.010UF, K, 10V	1	
	C4574	FIG1E103A123	C 0.010UF, K, 16V	1	
	C4575	FIG1A1050032	C 10UF, 50V	1	
	C4580	FIG1E103A123	C 0.010UF, K, 16V	1	
	C4585	FIG1A1050032	C 10UF, 50V	1	
	C4595	FIG1E103A123	C 0.010UF, K, 16V	1	
	C4596	FIG1C104A116	C 0.10UF, K, 16V	1	
	C4598	FIG1A1050032	C 10UF, 50V	1	
	C4599	F2G0J470A019	E 47UF 6.3V	1	
	C4600	FIG1C104A116	C 0.10UF, K, 16V	1	
	C4601	F2G0J470A019	E 47UF 6.3V	1	
	C4602	FIG1C104A116	C 0.10UF, K, 16V	1	
	C4603	FIG1H0J2250008	C 2.2UF, K, 16V	1	
	C4604	FIG1H471A730	C 470UF, 50V	1	
	C4605	FIG1A1050032	C 10UF, 50V	1	
	C4606	FLJ1A475A039	C 4.7UF, K, 10V	1	
	C4607	FLJ1A475A039	C 4.7UF, K, 10V	1	
	C4608	FIG1C104A116	C 0.10UF, K, 16V	1	
	C4612	FIG1E103A123	C 0.010UF, K, 16V	1	
	C4613	FIG1A1050032	C 10UF, 50V	1	
	C4614	FIG1C104A116	C 0.10UF, K, 16V	1	
	C4616	FLJ1A475A039	C 4.7UF, K, 10V	1	
	C4617	FLJ0G2260001	C 0.001UF, 6.3V	1	
	C4619	FIG1C104A116	C 0.10UF, K, 16V	1	
	C4624	FIG1C104A116	C 0.10UF, K, 16V	1	
	C4625	FIG1C104A116	C 0.10UF, K, 16V	1	
	C4626	FIG1C104A116	C 0.10UF, K, 16V	1	
	C4627	FIG1C104A116	C 0.10UF, K, 16V	1	
	C4628	FIG1C104A116	C 0.10UF, K, 16V	1	
	C4630	FIG1C104A116	C 0.10UF, K, 16V	1	
	C4632	FIG1A1050032	C 10UF, 50V	1	
	C4634	FIG1A1050032	C 10UF, 50V	1	
	C4636	FIG1A1050032	C 10UF, 50V	1	
	C4638	FIG1A1050032	C 10UF, 50V	1	
	C4640	FIG1A1050032	C 10UF, 50V	1	
	C4642	FIG1A1050032	C 10UF, 50V	1	
	C4643	FIG1C104A116	C 0.10UF, K, 16V	1	
	C4644	FIG1C104A116	C 0.10UF, K, 16V	1	
	C4645	FIG1C104A116	C 0.10UF, K, 16V	1	
	C4646	FIG1C104A116	C 0.10UF, K, 16V	1	
	C4807	FIG1C104A116	C 0.10UF, K, 16V	1	
	C4831	FIG1C104A116	C 0.10UF, K, 16V	1	
	C5400	FLJ1A106A043	C 0.010UF, K, 10V	1	
	C5401	FIG1E104A129	C 0.1UF, 25V	1	

Safety	Ref. No.	Part No.	Part Name & Description	Pcs	Remarks
	C5402	FIG1E103A123	C 0.010UF, K, 16V	1	
	C5404	FIG1H392A970	C 3900PF, K, 50V	1	
	C5405	FIG1E104A129	C 0.1UF, 25V	1	
	C5406	ECJ3YB1E106M	C 10 UF, K, 25V	1	
	C5408	FLJ1A106A043	C 0.010UF, K, 10V	1	
	C5412	FIG1C1060004	C 0.010UF, 16V	1	
	C5413	FIG1E104A129	C 0.1UF, 25V	1	
	C5414	FIG1E103A123	C 0.010UF, K, 16V	1	
	C5416	FIG1H472A970	C 4700PF, K, 50V	1	
	C5417	FIG1E104A129	C 0.1UF, 25V	1	
	C5418	ECJ3YB1E106M	C 10 UF, K, 25V	1	
	C5420	FIG1C1060004	C 0.010UF, 16V	1	
	C5511	ECJ3YB1E106M	C 10 UF, K, 25V	1	
	C5512	FIG1E103A123	C 0.010UF, K, 16V	1	
	C5516	FLJ1A106A043	C 0.010UF, K, 10V	1	
	C5517	FIG1C104A116	C 0.10UF, K, 16V	1	
	C5520	F2G0J2210013	E 220UF 6.3V	1	
	C5521	FIG1C104A116	C 0.10UF, K, 16V	1	
	C5522	FIG1C104A116	C 0.10UF, K, 16V	1	
	C5596	FIG1H1020008	C 1000UF, 50V	1	
	C5597	FIG1H1020008	C 1000UF, 50V	1	
	C5600	FIG1A1050032	C 10UF, 50V	1	
	C5601	FIG1C104A116	C 0.10UF, K, 16V	1	
	C5602	ECGRLOG680ER	C 68PF, J, 4V	1	
	C5603	FIG1E103A123	C 0.010UF, K, 16V	1	
	C5604	FIG1E103A123	C 0.010UF, K, 16V	1	
	C5605	FLJ1A475A039	C 4.7UF, K, 10V	1	
	C5606	FIG1H471A730	C 470UF, 50V	1	
	C5607	FIG1H221A731	C 220UF, 50V	1	
	C5608	FIG1C104A116	C 0.10UF, K, 16V	1	
	C5611	ECJ3YB1E106M	C 10 UF, K, 25V	1	
	C5612	ECJ3YB1E106M	C 10 UF, K, 25V	1	
	C5615	ECJ3YB1E106M	C 10 UF, K, 25V	1	
	C5616	FIG1A473A053	C 0.47UF, 10V	1	
	C5617	FIG1A1050032	C 10UF, 50V	1	
	C5620	FIG1E104A129	C 0.1UF, 25V	1	
	C5621	FIG1E103A123	C 0.010UF, K, 16V	1	
	C5622	FLJ1A475A039	C 4.7UF, K, 10V	1	
	C5623	FIG1H471A730	C 470UF, 50V	1	
	C5624	FIG1H221A731	C 220UF, 50V	1	
	C5625	FIG1E103A123	C 0.010UF, K, 16V	1	
	C5626	FIG1C104A116	C 0.10UF, K, 16V	1	
	C5627	FIG1C104A116	C 0.10UF, K, 16V	1	
	C5628	ECGRLOG680ER	C 68PF, J, 4V	1	
	C5629	ECGRLOG680ER	C 68PF, J, 4V	1	
	C5640	FIG1C104A116	C 0.10UF, K, 16V	1	
	C5641	FIG1C104A116	C 0.10UF, K, 16V	1	
	C5642	ECJ3YB1E106M	C 10 UF, K, 25V	1	
	C5643	FIG1E104A129	C 0.1UF, 25V	1	
	C5657	FIG1A225A051	C 22UF, 50V	1	
	C5658	FIG1E103A123	C 0.010UF, K, 16V	1	
	C5661	FIG1E103A123	C 0.010UF, K, 16V	1	
	C5662	FIG1A473A053	C 0.47UF, 10V	1	
	C5663	FIG1E103A123	C 0.010UF, K, 16V	1	
	C5696	EEH1E470P	C 47PF, J, 25V	1	
	C5697	FIG1E105A171	C 1 UF 25V	1	
	C5699	ECJ3YB1E106M	C 10 UF, K, 25V	1	
	C5700	ECJ3YB1E106M	C 10 UF, K, 25V	1	
	C5703	FIG1H101A565	C 100PF, K, 50V	1	
	C5704	FIG1H101A565	C 100PF, K, 50V	1	
	C7701	FIG1H330A731	C 33UF, 50V	1	
	C7702	F2G0G470A007	E 47UF 6.3V	1	
	C7703	FIG1H330A731	C 33UF, 50V	1	



Safety	Ref. No.	Part No.	Part Name & Description	Pcs	Remarks
	C7705	F1G1C104A119	C 0.10UF, K, 16V	1	
	C7708	F1G1C104A119	C 0.10UF, K, 16V	1	
	C7709	F1G1C104A119	C 0.10UF, K, 16V	1	
	C7726	F1G1H330A731	C 33UF, 50V	1	
	C7727	F1G1H330A731	C 33UF, 50V	1	
	C7729	F1J0J106A020	C 0.010UF, K, 16V	1	
	C8001	F1G1C104A116	C 0.10UF, K, 16V	1	
	C8002	F1H0J1050012	C 1UF, K, 16V	1	
	C8003	F1H0J1050012	C 1UF, K, 16V	1	
	C8004	F1H0J1050012	C 1UF, K, 16V	1	
	C8005	F1H0J1050012	C 1UF, K, 16V	1	
	C8006	F1G1C104A116	C 0.10UF, K, 16V	1	
	C8007	F1G1C104A116	C 0.10UF, K, 16V	1	
	C8008	F1G1C104A116	C 0.10UF, K, 16V	1	
	C8009	F1J1A106A043	C 0.010UF, K, 10V	1	
	C8010	F1J1A106A043	C 0.010UF, K, 10V	1	
	C8011	F1G1C104A116	C 0.10UF, K, 16V	1	
	C8012	F1G1C104A116	C 0.10UF, K, 16V	1	
	C8013	F1G1C104A116	C 0.10UF, K, 16V	1	
	C8014	F1G1C104A116	C 0.10UF, K, 16V	1	
	C8015	F1H0J1050012	C 1UF, K, 16V	1	
	C8016	F1H0J1050012	C 1UF, K, 16V	1	
	C8017	F1J1A106A043	C 0.010UF, K, 10V	1	
	C8018	F1G1C104A116	C 0.10UF, K, 16V	1	
	C8019	F1G1C104A116	C 0.10UF, K, 16V	1	
	C8020	F1G1C104A116	C 0.10UF, K, 16V	1	
	C8021	F1G1C104A116	C 0.10UF, K, 16V	1	
	C8022	F1H0J1050012	C 1UF, K, 16V	1	
	C8023	F1J1A106A043	C 0.010UF, K, 10V	1	
	C8024	F1J1A106A043	C 0.010UF, K, 10V	1	
	C8025	F1G1C104A116	C 0.10UF, K, 16V	1	
	C8026	F1G1C104A116	C 0.10UF, K, 16V	1	
	C8027	F1G1C104A116	C 0.10UF, K, 16V	1	
	C8028	F1G1C104A116	C 0.10UF, K, 16V	1	
	C8029	F1G1C104A116	C 0.10UF, K, 16V	1	
	C8030	F1H0J1050012	C 1UF, K, 16V	1	
	C8031	F1H0J1050012	C 1UF, K, 16V	1	
	C8032	F1J1A106A043	C 0.010UF, K, 10V	1	
	C8033	F1G1C104A116	C 0.10UF, K, 16V	1	
	C8034	F1G1C104A116	C 0.10UF, K, 16V	1	
	C8035	F1J1A106A043	C 0.010UF, K, 10V	1	
	C8036	F1J1A106A043	C 0.010UF, K, 10V	1	
	C8037	F1G1C104A116	C 0.10UF, K, 16V	1	
	C8038	F1G1C104A116	C 0.10UF, K, 16V	1	
	C8039	F1G1C104A116	C 0.10UF, K, 16V	1	
	C8040	F1G1C104A116	C 0.10UF, K, 16V	1	
	C8041	F1G1C104A116	C 0.10UF, K, 16V	1	
	C8042	ECRLOG680ER	C 68PF, J, 4V	1	
	C8043	F1G1C104A116	C 0.10UF, K, 16V	1	
	C8044	F1G1C104A116	C 0.10UF, K, 16V	1	
	C8045	F1G1C104A116	C 0.10UF, K, 16V	1	
	C8046	F1G1C104A116	C 0.10UF, K, 16V	1	
	C8047	F1G1C104A116	C 0.10UF, K, 16V	1	
	C8048	F1G1C104A116	C 0.10UF, K, 16V	1	
	C8049	F1G1C104A116	C 0.10UF, K, 16V	1	
	C8050	F1G1C104A116	C 0.10UF, K, 16V	1	
	C8051	F1G1C104A116	C 0.10UF, K, 16V	1	
	C8052	F1H0J1050012	C 1UF, K, 16V	1	
	C8053	F1G1E103A123	C 0.010UF, K, 16V	1	
	C8054	F1G1H180A731	C 18UF, 50V	1	
	C8055	F1G1H7R0A732	C 7.0UF, 50V	1	
	C8056	F1G1C104A116	C 0.10UF, K, 16V	1	
	C8057	F1G1C104A116	C 0.10UF, K, 16V	1	
	C8058	F1J1A106A043	C 0.010UF, K, 10V	1	

Safety	Ref. No.	Part No.	Part Name & Description	Pcs	Remarks
	C8067	F1G1E103A123	C 0.010UF, K, 16V	1	
	C8068	F1G1C104A116	C 0.10UF, K, 16V	1	
	C8069	F1G1H820A731	C 82UF, 50V	1	
	C8070	F1G1C104A116	C 0.10UF, K, 16V	1	
	C8071	F1G1C104A116	C 0.10UF, K, 16V	1	
	C8072	F1G1C104A116	C 0.10UF, K, 16V	1	
	C8073	F1G1C104A116	C 0.10UF, K, 16V	1	
	C8074	F1G1C104A116	C 0.10UF, K, 16V	1	
	C8075	F1J0G2260001	C 0.001UF, 6.3V	1	
	C8076	F1G1C104A116	C 0.10UF, K, 16V	1	
	C8077	F1G1C104A116	C 0.10UF, K, 16V	1	
	C8078	F1G1C104A116	C 0.10UF, K, 16V	1	
	C8079	F1G1C104A116	C 0.10UF, K, 16V	1	
	C8080	F1G1C104A116	C 0.10UF, K, 16V	1	
	C8555	F1G1C104A116	C 0.10UF, K, 16V	1	
	C8601	F1G1C104A116	C 0.10UF, K, 16V	1	
	C9033	F1G1C104A116	C 0.10UF, K, 16V	1	
	C9034	F1G1C104A116	C 0.10UF, K, 16V	1	
	C9035	F1J1A106A043	C 0.010UF, K, 10V	1	
	C9036	F1J1A106A043	C 0.010UF, K, 10V	1	
	C9037	F1G1E103A123	C 0.010UF, K, 16V	1	
	C9040	F1G1C104A116	C 0.10UF, K, 16V	1	
	C9044	F1J0J475A035	C 4.7UF, K, 16V	1	
	C9045	F1G1C104A116	C 0.10UF, K, 16V	1	
	C9046	F1G1C104A116	C 0.10UF, K, 16V	1	
	C9047	F1G1C104A116	C 0.10UF, K, 16V	1	
	C9048	F1G1C104A116	C 0.10UF, K, 16V	1	
	C9049	F1G1C104A116	C 0.10UF, K, 16V	1	
	C9050	F1G1C104A116	C 0.10UF, K, 16V	1	
	C9051	F1G1C104A116	C 0.10UF, K, 16V	1	
	C9052	F1G1C104A116	C 0.10UF, K, 16V	1	
	C9053	F1G1C104A116	C 0.10UF, K, 16V	1	
	C9055	F1G1C104A116	C 0.10UF, K, 16V	1	
	C9056	F1G1C104A116	C 0.10UF, K, 16V	1	
	C9057	F1G1C104A116	C 0.10UF, K, 16V	1	
	C9061	F1G1C104A116	C 0.10UF, K, 16V	1	
	C9062	F1J0J475A035	C 4.7UF, K, 16V	1	
	C9063	F1G1C104A116	C 0.10UF, K, 16V	1	
	C9064	F1G1C104A116	C 0.10UF, K, 16V	1	
	C9065	F1G1C104A116	C 0.10UF, K, 16V	1	
	C9468	F1G1E103A123	C 0.010UF, K, 16V	1	
	C9469	F1G1C104A116	C 0.10UF, K, 16V	1	
	C9535	F1G1C104A116	C 0.10UF, K, 16V	1	
	C9536	F1G1C104A116	C 0.10UF, K, 16V	1	
	C9537	F1G1C104A116	C 0.10UF, K, 16V	1	
	C9538	F1G1C104A116	C 0.10UF, K, 16V	1	
	C9539	F1G1C104A116	C 0.10UF, K, 16V	1	
	C9540	F1G1C104A116	C 0.10UF, K, 16V	1	
	C9541	F1G1C104A116	C 0.10UF, K, 16V	1	
	C9542	F1G1C104A116	C 0.10UF, K, 16V	1	
	C9543	F1G1C104A116	C 0.10UF, K, 16V	1	
	C9544	F1G1C104A116	C 0.10UF, K, 16V	1	
	C9545	F1G1C104A116	C 0.10UF, K, 16V	1	
	C9546	F1G1C104A116	C 0.10UF, K, 16V	1	
	C9547	F1G1C104A116	C 0.10UF, K, 16V	1	
	C9548	F1G1C104A116	C 0.10UF, K, 16V	1	
	C9549	F1G1C104A116	C 0.10UF, K, 16V	1	
	C9550	F1G1C104A116	C 0.10UF, K, 16V	1	
	C9825	F1G1H101A731	C 100PF, K, 50V	1	
	C9832	F1J1A106A043	C 0.010UF, K, 10V	1	
	C9840	F1G1E103A123	C 0.010UF, K, 16V	1	
	C9841	F1G1C104A116	C 0.10UF, K, 16V	1	
	C9842	F1G1C104A116	C 0.10UF, K, 16V	1	
	C9858	ECJ3YB1E106M	C 10 UF, K, 25V	1	
	C9859	F1G1E103A123	C 0.010UF, K, 16V	1	
	C9860	F1J0J475A035	C 4.7UF, K, 16V	1	
	C9861	F1H1E104A129	C 0.1UF, 25V	1	

Safety	Ref. No.	Part No.	Part Name & Description	Pcs	Remarks
	C9862	FIH1E104A129	C 0.1UF, 25V	1	
	C9863	FIJ0J475A035	C 4.7UF, K, 16V	1	
	C9864	FIH1E104A129	C 0.1UF, 25V	1	
	C9865	ECGRLOG680ER	C 68PF, J, 4V	1	
	C9866	ECGRLOG680ER	C 68PF, J, 4V	1	
	C9867	ECJ3YB1E106M	C 10 UF, K, 25V	1	
	C9868	ECJ3YB1E106M	C 10 UF, K, 25V	1	
	C9869	ECJ3YB1E106M	C 10 UF, K, 25V	1	
	C9870	ECJ3YB1E106M	C 10 UF, K, 25V	1	
	C9871	ECJ3YB1E106M	C 10 UF, K, 25V	1	
	C9872	ECJ3YB1E106M	C 10 UF, K, 25V	1	
	C9873	ECGRLOG680ER	C 68PF, J, 4V	1	
	C9874	FIG1H680A731	C 68UF, 50V	1	
	C9877	FIG1H680A731	C 68UF, 50V	1	
	C9878	FIG1E103A123	C 0.010UF, K, 16V	1	
	C9879	FIG1C153A116	C 0.015UF, K, 16V	1	
	C9880	FIG1A563A032	C 0.56UF, 10V	1	
	C9881	FIG1E103A123	C 0.010UF, K, 16V	1	
	C9882	FIG1E822A086	C 8200UF, Z, 25V	1	
	C9883	FIG1H101A731	C 100PF, K, 50V	1	
	C9884	FIG1H102A730	C 1000UF, 50V	1	
	C9885	FIG1H102A730	C 1000UF, 50V	1	
	C9886	FIH1E104A129	C 0.1UF, 25V	1	
	C9887	FIH1E104A129	C 0.1UF, 25V	1	
	C9888	FIG1H361A565	C 360UF, 50V	1	
	C9900	FIG1C104A116	C 0.10UF, K, 16V	1	
	C9901	FIG1C104A116	C 0.10UF, K, 16V	1	
	C9902	FIG1C104A116	C 0.10UF, K, 16V	1	
	C9903	FIG1C104A116	C 0.10UF, K, 16V	1	
	C9904	FIG1C104A116	C 0.10UF, K, 16V	1	
	C9905	FIG1C104A116	C 0.10UF, K, 16V	1	
	C9906	FIG1C104A116	C 0.10UF, K, 16V	1	
	C9907	FIG1C104A116	C 0.10UF, K, 16V	1	
	C9908	FIG1C104A116	C 0.10UF, K, 16V	1	
	C9909	FIG1C104A116	C 0.10UF, K, 16V	1	
	C9910	FIG1C104A116	C 0.10UF, K, 16V	1	
	C9911	FIG1C104A116	C 0.10UF, K, 16V	1	
	C9912	FIG1C104A116	C 0.10UF, K, 16V	1	
	C9913	FIG1C104A116	C 0.10UF, K, 16V	1	
	C9914	FIG1C104A116	C 0.10UF, K, 16V	1	
	C9915	FIG1C104A116	C 0.10UF, K, 16V	1	
	C9916	FIG1C104A116	C 0.10UF, K, 16V	1	
	C9917	FIG1C104A116	C 0.10UF, K, 16V	1	
	C9918	FIG1C104A116	C 0.10UF, K, 16V	1	
	C9919	FIG1C104A116	C 0.10UF, K, 16V	1	
	C9920	FIG1C104A116	C 0.10UF, K, 16V	1	
	C9921	FIG1C104A116	C 0.10UF, K, 16V	1	
	C9922	FIG1C104A116	C 0.10UF, K, 16V	1	
	C9923	FIG1C104A116	C 0.10UF, K, 16V	1	
	C9924	FIG1C104A116	C 0.10UF, K, 16V	1	
	C9925	FIG1C104A116	C 0.10UF, K, 16V	1	
	C9927	FIG1C104A116	C 0.10UF, K, 16V	1	
	C9928	FIG1C104A116	C 0.10UF, K, 16V	1	
	C9929	FIG1C104A116	C 0.10UF, K, 16V	1	
	C9930	FIG1C104A116	C 0.10UF, K, 16V	1	
	C9931	FIG1C104A116	C 0.10UF, K, 16V	1	
	C9932	FIG1C104A116	C 0.10UF, K, 16V	1	
	C9933	FIG1C104A116	C 0.10UF, K, 16V	1	
	C9934	FIG1C104A116	C 0.10UF, K, 16V	1	
	C9935	FIG1C104A116	C 0.10UF, K, 16V	1	
	C9936	FIG1C104A116	C 0.10UF, K, 16V	1	
	C9937	FIG1C104A116	C 0.10UF, K, 16V	1	
	C9938	FIG1C104A116	C 0.10UF, K, 16V	1	
	C9939	FIG1C104A116	C 0.10UF, K, 16V	1	
	C9940	FIG1C104A116	C 0.10UF, K, 16V	1	
	C9941	FIG1C104A116	C 0.10UF, K, 16V	1	
	C9942	FIG1C104A116	C 0.10UF, K, 16V	1	
	C9943	FIG1C104A116	C 0.10UF, K, 16V	1	
	C9944	FIG1C104A116	C 0.10UF, K, 16V	1	
	C9945	FIG1C104A116	C 0.10UF, K, 16V	1	
	C9946	FIG1C104A116	C 0.10UF, K, 16V	1	

Safety	Ref. No.	Part No.	Part Name & Description	Pcs	Remarks
	C9947	FIG1C104A116	C 0.10UF, K, 16V	1	
	C9948	FIG1C104A116	C 0.10UF, K, 16V	1	
	C9949	FIG1C104A116	C 0.10UF, K, 16V	1	
	C9950	FIG1C104A116	C 0.10UF, K, 16V	1	
	C9951	FIG1C104A116	C 0.10UF, K, 16V	1	
	C9952	FIG1C104A116	C 0.10UF, K, 16V	1	
	C9953	FIG1C104A116	C 0.10UF, K, 16V	1	
	C9954	FIG1C104A116	C 0.10UF, K, 16V	1	
	C9955	FIG1C104A116	C 0.10UF, K, 16V	1	
	C9956	FIG1C104A116	C 0.10UF, K, 16V	1	
	C9957	FIG1C104A116	C 0.10UF, K, 16V	1	
	C9958	FIG1C104A116	C 0.10UF, K, 16V	1	
	C9959	FIG1C104A116	C 0.10UF, K, 16V	1	
	C9961	FIJ1A106A043	C 0.010UF, K, 10V	1	
	C9962	FIJ1A106A043	C 0.010UF, K, 10V	1	
	C9965	FIG1C104A116	C 0.10UF, K, 16V	1	
	C9966	FIJ1A106A043	C 0.010UF, K, 10V	1	
	C9967	FIG1C104A116	C 0.10UF, K, 16V	1	
	C9968	FIG1C104A116	C 0.10UF, K, 16V	1	
	C9970	FIG1C104A116	C 0.10UF, K, 16V	1	
	C9971	FIG1H180A731	C 18UF, 50V	1	
	C9972	FIG1H150A731	C 15UF, 50V	1	
	C9973	FIG1C104A116	C 0.10UF, K, 16V	1	
	C9974	FIG1C104A116	C 0.10UF, K, 16V	1	
	C9975	FIG1C104A116	C 0.10UF, K, 16V	1	
	C9976	FIG1C104A116	C 0.10UF, K, 16V	1	
	C9977	FIG1C104A116	C 0.10UF, K, 16V	1	
	C9978	FIG1C104A116	C 0.10UF, K, 16V	1	
	C9979	FIG1C104A116	C 0.10UF, K, 16V	1	
	C9980	FIG1C104A116	C 0.10UF, K, 16V	1	
	C14901	FIJ1H102A834	C 1000UF, 50V	1	
	C14902	FIJ1C1050030	C 1UF, Z, 16V	1	
	C14904	FIJ1C1050030	C 1UF, Z, 16V	1	
	C14906	FIJ1C1050030	C 1UF, Z, 16V	1	
	C14908	FIJ1C1050030	C 1UF, Z, 16V	1	
	C14909	FIL2J1020001	C 1000UF, K, 6.3V	1	
	C14910	FIJ1C1050030	C 1UF, Z, 16V	1	
	C14912	FIJ1C1050030	C 1UF, Z, 16V	1	
	C14923	FIL2E104A028	E 1000UF, 25V	1	
	C14924	FIL2E104A028	E 1000UF, 25V	1	
	C14926	FIJ1H104A835	C 0.10UF, 50V	1	
	C14931	FIJ1H102A834	C 1000UF, 50V	1	
	C14932	FIL2E104A028	E 1000UF, 25V	1	
	C14933	FIL2E104A028	E 1000UF, 25V	1	
	C14934	FIL2E104A028	E 1000UF, 25V	1	
	C14935	FIL2E104A028	E 1000UF, 25V	1	
	C14936	FIJ1H221A709	C 220UF, 50V	1	
	C14937	FIJ1H221A709	C 220UF, 50V	1	
	C14938	FIJ1H221A709	C 220UF, 50V	1	
	C14939	FIJ1H221A709	C 220UF, 50V	1	
	C14940	FIJ1H102A834	C 1000UF, 50V	1	
	C14941	FIJ1H221A709	C 220UF, 50V	1	
	C14942	FIJ1H221A709	C 220UF, 50V	1	
	C14943	FIL1E4750012	C 4.7UF, 25V	1	
	C14950	FIJ1H221A709	C 220UF, 50V	1	
	C14952	FIJ1C1050030	C 1UF, Z, 16V	1	
	C14955	FIJ1C1050030	C 1UF, Z, 16V	1	
	C14957	FIJ1C1050030	C 1UF, Z, 16V	1	
	C14958	FIJ1C1050030	C 1UF, Z, 16V	1	
	C14959	FIL2J1020001	C 1000UF, K, 6.3V	1	
	C14961	FIJ1C1050030	C 1UF, Z, 16V	1	
	C14963	FIJ1C1050030	C 1UF, Z, 16V	1	
	C14969	FIJ1H104A835	C 0.10UF, 50V	1	
	C14970	FIJ1H221A709	C 220UF, 50V	1	
	C14971	FIJ1H221A709	C 220UF, 50V	1	
	C14972	FIJ1H221A709	C 220UF, 50V	1	
	C14973	FIJ1H102A834	C 1000UF, 50V	1	
	C14974	FIL2E104A028	E 1000UF, 25V	1	
	C14975	FIL2E104A028	E 1000UF, 25V	1	
	C14976	FIJ1H102A834	C 1000UF, 50V	1	
	C14977	FIL2E104A028	E 1000UF, 25V	1	

Safety	Ref. No.	Part No.	Part Name & Description	Pcs	Remarks
	C14978	F1L2E104A028	E 1000UF, 25V	1	
	C14981	F1J1H221A709	C 220UF, 50V	1	
	C14984	F1L2E104A028	E 1000UF, 25V	1	
	C14985	F1L2E104A028	E 1000UF, 25V	1	
	C14986	F1J1H101A836	C 100PF, K, 50V	1	
	C14987	F1J1H104A835	C 0.10UF, 50V	1	
	C14988	F1J1H104A835	C 0.10UF, 50V	1	
	C14989	F1J1H221A709	C 220UF, 50V	1	
	C14991	F1H1H100A971	C 10PF, K, 50V	1	
	C14992	F1H1C105A008	C 1UF, K, 16V	1	
	C14993	F1H1C105A008	C 1UF, K, 16V	1	
	C16001	F1L2J562A022	C 5600UF, K,6.3V	1	
	C16011	F2A2T201A006	E 200UF, 220V	1	
	C16012	F2A2T201A006	E 200UF, 220V	1	
	C16013	F2A2T201A006	E 200UF, 220V	1	
	C16015	F0C2E225A230	E 0.022UF, 250V	1	
	C16023	F1L2J562A022	C 5600UF, K,6.3V	1	
	C16041	F1H1H392A970	C 3900PF, K, 50V	1	
	C16071	F1L2J1020001	C 1000UF, K,6.3V	1	
	C16092	F1L2J1020001	C 1000UF, K,6.3V	1	
	C16131	F1L1E4750012	C 4.7UF, 25V	1	
	C16133	F1L1E4750012	C 4.7UF, 25V	1	
	C16135	F1K1E105A029	C 1UF, Z, 25V	1	
	C16151	F1K1E105A029	C 1UF, Z, 25V	1	
	C16152	F1L1E4750012	C 4.7UF, 25V	1	
	C16153	F1L1E4750012	C 4.7UF, 25V	1	
	C16154	F1L1E4750012	C 4.7UF, 25V	1	
	C16192	F1L1E4750012	C 4.7UF, 25V	1	
	C16194	F1L1E4750012	C 4.7UF, 25V	1	
	C16195	F1L1E4750012	C 4.7UF, 25V	1	
	C16197	F1L1E4750012	C 4.7UF, 25V	1	
	C16201	F0C2E225A230	E 0.022UF, 250V	1	
	C16202	F0C2E225A230	E 0.022UF, 250V	1	
	C16203	F0C2E225A230	E 0.022UF, 250V	1	
	C16204	F0C2E225A230	E 0.022UF, 250V	1	
	C16241	F2A1A101A106	E 100UF, 10V	1	
	C16242	F1H1C105A008	C 1UF, K, 16V	1	
	C16243	F1J1H103A834	C 0.01UF, K, 50V	1	
	C16251	F1H1C105A008	C 1UF, K, 16V	1	
	C16252	F1K1E105A029	C 1UF, Z, 25V	1	
	C16261	F2A2A471A397	E 470UF, 100V	1	
	C16272	F2A1E471A487	E 470UF, 25V	1	
	C16280	F1K1E105A029	C 1UF, Z, 25V	1	
	C16284	ECJ1VB1H104K	C 0.1UF, K, 50V	1	
	C16285	ECJ1VB1H104K	C 0.1UF, K, 50V	1	
	C16301	F2A1E470A454	E 47UF, 25V	1	
	C16302	F1H1H471A219	C 470UF, 50V	1	
	C16310	F2A2T201A006	E 200UF, 220V	1	
	C16311	F1H1A1050032	C 10UF, 50V	1	
	C16312	F1H1H472A970	C 4700PF, K, 50V	1	
	C16313	F1H1C105A008	C 1UF, K, 16V	1	
	C16321	F1L2E224A028	E 2200UF, 25V	1	
	C16322	F1L2E224A028	E 2200UF, 25V	1	
	C16323	F2A1E470A454	E 47UF, 25V	1	
	C16324	F2A1E471A487	E 470UF, 25V	1	
	C16326	F1L1E4750012	C 4.7UF, 25V	1	
	C16328	F2A2D221A220	E 220UF, 100V	1	
	C16336	F1H1H102A970	C 1000PF, K, 50V	1	
	C16337	ECJ1VB1H104K	C 0.1UF, K, 50V	1	
	C16402	F1L2J562A022	C 5600UF, K,6.3V	1	
	C16411	F2A2T201A006	E 200UF, 220V	1	
	C16413	F2A2T201A006	E 200UF, 220V	1	
	C16414	F0C2E225A230	E 0.022UF, 250V	1	
	C16418	F2A2T201A006	E 200UF, 220V	1	
	C16419	F2A2T201A006	E 200UF, 220V	1	
	C16421	F1L2J562A022	C 5600UF, K,6.3V	1	
	C16441	F1H1H392A970	C 3900PF, K, 50V	1	
	C16471	F1L2J1020001	C 1000UF, K,6.3V	1	
	C16472	F1K1E105A029	C 1UF, Z, 25V	1	
	C16480	F1J1H104A835	C 0.10UF, 50V	1	
	C16491	F1L2J1020001	C 1000UF, K,6.3V	1	
	C16502	F1L1E4750012	C 4.7UF, 25V	1	
	C16504	F1L1E4750012	C 4.7UF, 25V	1	

Safety	Ref. No.	Part No.	Part Name & Description	Pcs	Remarks
	C16505	F1K1E105A029	C 1UF, Z, 25V	1	
	C16521	F1K1E105A029	C 1UF, Z, 25V	1	
	C16522	F1L1E4750012	C 4.7UF, 25V	1	
	C16524	F1L1E4750012	C 4.7UF, 25V	1	
	C16525	F1L1E4750012	C 4.7UF, 25V	1	
	C16562	F1H1C105A008	C 1UF, K, 16V	1	
	C16563	F2A1A101A106	E 100UF, 10V	1	
	C16564	F1H1C105A008	C 1UF, K, 16V	1	
	C16565	F1J1H103A834	C 0.01UF, K, 50V	1	
	C16566	F1J1H103A834	C 0.01UF, K, 50V	1	
	C16581	F1K1E105A029	C 1UF, Z, 25V	1	
	C16582	F1H1C105A008	C 1UF, K, 16V	1	
	C16593	F1J1H102A836	C 1000UF, 50V	1	
	C16603	F1K2J102A014	C 1000UF, K,6.3V	1	
	C16604	F1K2J102A014	C 1000UF, K,6.3V	1	
	C16605	F1L2J472A022	C 4700UF, K,6.3V	1	
	C16606	F1L2J472A022	C 4700UF, K,6.3V	1	
	C16608	F1H1H221A971	C 220UF, K, 50V	1	
	C16632	F0C2E225A230	E 0.022UF, 250V	1	
	C16633	F0C2E225A230	E 0.022UF, 250V	1	
	C16634	F0C2E225A230	E 0.022UF, 250V	1	
	C16635	F0C2E225A230	E 0.022UF, 250V	1	
	C16641	ECQE2105RKB	P 1UF, 250V	1	
	C16661	F1K2J102A014	C 1000UF, K,6.3V	1	
	C16662	F1K2J102A014	C 1000UF, K,6.3V	1	
	C16664	F1J1H680A836	C 68PF, K, 50V	1	
	C16665	F1J1H680A836	C 68PF, K, 50V	1	
	C16666	F1J1H680A836	C 68PF, K, 50V	1	
	C16691	ECA2CM101	E 100UF, 160V	1	
	C16708	F1J1H104A835	C 0.10UF, 50V	1	
	C16721	F2A1H101A493	E 100UF, 50V	1	
	C16723	F1L1E4750012	C 4.7UF, 25V	1	
	C16724	F1L1E4750012	C 4.7UF, 25V	1	
	C16725	F1L1E4750012	C 4.7UF, 25V	1	
	C16752	F1K1E105A029	C 1UF, Z, 25V	1	
	C16753	F1L1E4750012	C 4.7UF, 25V	1	
	C16755	F1L1E4750012	C 4.7UF, 25V	1	
	C16756	F1L1E4750012	C 4.7UF, 25V	1	
	C16773	F1L1E4750012	C 4.7UF, 25V	1	
	C16775	F1L1E4750012	C 4.7UF, 25V	1	
	C16791	F2A1E221A487	E 220UF, 25V	1	
	C16795	F2A1E471A487	E 470UF, 25V	1	
	C16806	ECA2CM101	E 100UF, 160V	1	
	C16812	F1L1E4750012	C 4.7UF, 25V	1	
	C16813	ECA2CM101	E 100UF, 160V	1	
	C16821	F1J1H104A835	C 0.10UF, 50V	1	
	C16822	F2A2G470A019	E 47UF, 400V	1	
	C16823	F1L2J562A022	C 5600UF, K,6.3V	1	
	C16832	F1J1H392A834	C 3900UF, 50V	1	
	C16842	ECA2CM101	E 100UF, 160V	1	
	C16843	F1J1H104A835	C 0.10UF, 50V	1	
	C16844	F1J1H104A835	C 0.10UF, 50V	1	
	C16855	F1H1C105A008	C 1UF, K, 16V	1	
	C16856	F1H1A1050032	C 10UF, 50V	1	
	C16857	F1H1H472A970	C 4700PF, K, 50V	1	
	C16858	F1H1C104A143	C 0.1UF, K, 16V	1	
	C16860	F1H1A1050032	C 10UF, 50V	1	
	C16861	F1H1H472A970	C 4700PF, K, 50V	1	
	C16862	F1H1C104A143	C 0.1UF, K, 16V	1	
	C16863	F1J1H103A834	C 0.01UF, K, 50V	1	
	C16864	F1J1H104A835	C 0.10UF, 50V	1	
	C16866	F1H1A1050032	C 10UF, 50V	1	
	C16867	F1H1H472A970	C 4700PF, K, 50V	1	
	C16868	F1H1C104A143	C 0.1UF, K, 16V	1	
	C16869	F1J1H104A835	C 0.10UF, 50V	1	
	C17121	F1H1A1050032	C 10UF, 50V	1	
	C17122	F1H1A1050032	C 10UF, 50V	1	
	C17123	F1L2E154A009	E 1500UF, 25V	1	
	C17124	F1L2E154A009	E 1500UF, 25V	1	
	C17130	F1H1C104A143	C 0.1UF, K, 16V	1	
	C17131	F1H1A1050032	C 10UF, 50V	1	
	C17132	F1H1A1050032	C 10UF, 50V	1	
	C17133	F1L2E154A009	E 1500UF, 25V	1	

Safety	Ref. No.	Part No.	Part Name & Description	Pcs	Remarks
	C17134	F1L2E154A009	E 1500UF, 25V	1	
	C17141	F1H1A1050032	C 10UF, 50V	1	
	C17142	F1H1A1050032	C 10UF, 50V	1	
	C17143	F1L2E154A009	E 1500UF, 25V	1	
	C17144	F1L2E154A009	E 1500UF, 25V	1	
	C17148	F1H1C104A143	C 0.1UF, K, 16V	1	
	C17151	F1H1A1050032	C 10UF, 50V	1	
	C17152	F1H1A1050032	C 10UF, 50V	1	
	C17153	F1L2E154A009	E 1500UF, 25V	1	
	C17154	F1L2E154A009	E 1500UF, 25V	1	
	C17211	F1H1A1050032	C 10UF, 50V	1	
	C17212	F1L2E154A009	E 1500UF, 25V	1	
	C17213	F1L2E154A009	E 1500UF, 25V	1	
	C17214	F1H1A1050032	C 10UF, 50V	1	
	C17215	F1L2E154A009	E 1500UF, 25V	1	
	C17219	F1H1A1050032	C 10UF, 50V	1	
	C17221	F1H1A1050032	C 10UF, 50V	1	
	C17222	F1H1A1050032	C 10UF, 50V	1	
	C17223	F1L2E154A009	E 1500UF, 25V	1	
	C17224	F1L2E154A009	E 1500UF, 25V	1	
	C17229	F1H1C104A143	C 0.1UF, K, 16V	1	
	C17230	F1K2A105A006	C 1UF, 100V	1	
	C17231	F1H1A1050032	C 10UF, 50V	1	
	C17232	F1H1A1050032	C 10UF, 50V	1	
	C17233	F1L2E154A009	E 1500UF, 25V	1	
	C17234	F1L2E154A009	E 1500UF, 25V	1	
	C17240	F1H1A1050032	C 10UF, 50V	1	
	C17241	F1L2E154A009	E 1500UF, 25V	1	
	C17244	F1H1C104A143	C 0.1UF, K, 16V	1	
	C17245	F1H1C104A143	C 0.1UF, K, 16V	1	
	CB1	K1MN68BA0052	68P CONNECTOR	1	
	CB2	K1MN68BA0052	68P CONNECTOR	1	
	CB3	K1MN68BA0052	68P CONNECTOR	1	
	CB4	K1MN68BA0052	68P CONNECTOR	1	
	CB5	K1MN68BA0052	68P CONNECTOR	1	
	CB6	K1MN68BA0052	68P CONNECTOR	1	
	CB7	K1MN68BA0052	68P CONNECTOR	1	
	CB8	K1MN68BA0052	68P CONNECTOR	1	
	D1107	MA704A	DIODE	1	
	D2004	MA2J11100L	DIODE	1	
	D2005	MA2J11100L	DIODE	1	
	D2006	MA2J11100L	DIODE	1	
	D2007	MA2J11100L	DIODE	1	
	D2009	MA2J11100L	DIODE	1	
	D2010	MA2J11100L	DIODE	1	
	D2013	MA2J11100L	DIODE	1	
	D2014	MA2J11100L	DIODE	1	
	D2017	MA2J11100L	DIODE	1	
	D2020	MA3X78900L	ZENER DIODE	1	
	D2021	MAZ83600ML	ZENER DIODE	1	
	D2024	BOBC03900015	ZENER DIODE	1	
	D2201	MA704A	DIODE	1	
	D2301	BOHCMM000014	DIODE	1	
	D2302	BOHCMM000014	DIODE	1	
	D2512	MAZ80560ML	ZENER DIODE	1	
	D2520	LNJ107W5PRW	LED	1	
	D2524	MAZ80560ML	ZENER DIODE	1	
	D2530	MAZ80560ML	ZENER DIODE	1	
	D3006	MA8120M	ZENER DIODE	1	
	D3016	MAZ80560LL	ZENER DIODE	1	
	D3017	MAZ80560LL	ZENER DIODE	1	
	D3018	MAZ80560LL	ZENER DIODE	1	
	D3019	MAZ80560LL	ZENER DIODE	1	
	D3047	MA8120M	ZENER DIODE	1	
	D3050	MAZ80560LL	ZENER DIODE	1	
	D3051	MA8120M	ZENER DIODE	1	
	D3701	MAZ81400ML	ZENER DIODE	1	
	D3702	MAZ81400ML	ZENER DIODE	1	
	D3709	MAZ81400ML	ZENER DIODE	1	
	D3710	MAZ81400ML	ZENER DIODE	1	
	D3711	MAZ81400ML	ZENER DIODE	1	

Safety	Ref. No.	Part No.	Part Name & Description	Pcs	Remarks
	D4502	EZAEG2A50AX	DIODE	1	
	D4503	EZAEG2A50AX	DIODE	1	
	D4504	EZAEG2A50AX	DIODE	1	
	D4505	EZAEG2A50AX	DIODE	1	
	D4506	EZAEG2A50AX	DIODE	1	
	D4507	EZAEG2A50AX	DIODE	1	
	D4508	EZAEG2A50AX	DIODE	1	
	D4509	EZAEG2A50AX	DIODE	1	
	D4510	EZAEG2A50AX	DIODE	1	
	D4511	EZAEG2A50AX	DIODE	1	
	D4512	EZAEG2A50AX	DIODE	1	
	D4513	BOBC5R6A0275	DIODE	1	
	D4514	EZAEG2A50AX	DIODE	1	
	D4515	BOBC5R6A0275	DIODE	1	
	D4516	EZAEG2A50AX	DIODE	1	
	D4517	EZAEG2A50AX	DIODE	1	
	D4518	EZAEG2A50AX	DIODE	1	
	D4519	EZAEG2A50AX	DIODE	1	
	D4520	EZAEG2A50AX	DIODE	1	
	D4521	EZAEG2A50AX	DIODE	1	
	D4522	EZAEG2A50AX	DIODE	1	
	D4523	EZAEG2A50AX	DIODE	1	
	D4541	MA2J11100L	DIODE	1	
	D4542	MA2J11100L	DIODE	1	
	D4551	MA2J11100L	DIODE	1	
	D4552	MA2J11100L	DIODE	1	
	D5400	BOJCMEO00037	DIODE	1	
	D5401	BOBC4R700007	ZENER DIODE	1	
	D5402	BOBC4R700007	ZENER DIODE	1	
	D5403	BOJCMEO00037	DIODE	1	
	D5404	BOBC4R700007	ZENER DIODE	1	
	D5405	BOBC4R700007	ZENER DIODE	1	
	D5521	MA3X152D0L	DIODE	1	
	D5522	MA3X152D0L	DIODE	1	
	D5571	BOBC6R600005	ZENER DIODE	1	
	D5573	BOBC01100001	ZENER DIODE	1	
	D5600	BOBC4R000002	ZENER DIODE	1	
	D5601	MA22D3900L	DIODE	1	
	D5602	MA22D3900L	DIODE	1	
	D5603	BOJCD000002	DIODE	1	
	D5604	BOJCD000002	DIODE	1	
	D5605	MA22D3900L	DIODE	1	
	D5606	BOJCD000002	DIODE	1	
	D5607	BOBC4R000002	ZENER DIODE	1	
	D5608	BOBC4R000002	ZENER DIODE	1	
	D5612	MAZ80560LL	ZENER DIODE	1	
	D9017	BOBC3R3A0273	ZENER DIODE	1	
	D9018	BOBC3R3A0273	ZENER DIODE	1	
	D9019	BOBC3R3A0273	ZENER DIODE	1	
	D9021	BOJCCE000008	DIODE	1	
	D9807	BOJCCE000008	DIODE	1	
	D9808	BOJCCE000008	DIODE	1	
	D9812	MA22D3900L	DIODE	1	
	D9813	BOJCGD000002	DIODE	1	
	D9814	BOJCGD000002	DIODE	1	
	D9815	BOJCGD000002	DIODE	1	
	D9816	MA22D3900L	DIODE	1	
	D9817	MA22D3900L	DIODE	1	
	D14904	BOHCMM000013	DIODE	1	
	D14905	BOHCMM000013	DIODE	1	
	D14908	BOHCMM000013	DIODE	1	
	D14909	MA3X152E0L	ZENER DIODE	1	
	D14910	MA2J11100L	DIODE	1	
	D14953	BOHCMM000013	DIODE	1	
	D14956	BOHCMM000013	DIODE	1	
	D14958	BOHCMM000013	DIODE	1	
	D14959	MA2J11100L	DIODE	1	
	D14960	MA2J11100L	DIODE	1	
	D14961	MA8056H	ZENER DIODE	1	
	D14962	MA2J11100L	DIODE	1	
	D14971	MA2J11100L	DIODE	1	
	D14974	MA3X152E0L	ZENER DIODE	1	
	D14975	MA2J11100L	DIODE	1	

Safety	Ref. No.	Part No.	Part Name & Description	Pcs	Remarks
	D14976	MA2J11100L	DIODE	1	
	D16001	B0FBCN000005	DIODE	1	
	D16021	MA3DF30000LW	ZENER DIODE	1	
	D16032	MA2J11100L	DIODE	1	
	D16040	BOECKP000047	DIODE	1	
	D16041	MA3DF46000LW	ZENER DIODE	1	
	D16050	BOECKP000047	DIODE	1	
	D16051	B0FBCN000005	DIODE	1	
	D16102	MA22D3900L	DIODE	1	
	D16131	BOECKP000047	DIODE	1	
	D16132	BOECKP000047	DIODE	1	
	D16151	BOECKP000047	DIODE	1	
	D16152	BOECKP000047	DIODE	1	
	D16153	BOECKP000047	DIODE	1	
	D16191	BOECKP000047	DIODE	1	
	D16192	BOECKP000047	DIODE	1	
	D16253	LNJ301MPUJA	LED	1	
	D16255	MA2J11100L	DIODE	1	
	D16280	MA2J11100L	DIODE	1	
	D16281	MAZ80510LL	ZENER DIODE	1	
	D16282	MAZ80680ML	ZENER DIODE	1	
	D16284	MA3X152D0L	DIODE	1	
	D16300	BOECKP000047	DIODE	1	
	D16301	MA3X152E0L	ZENER DIODE	1	
	D16302	MA2J11100L	DIODE	1	
	D16311	MAZ81500ML	ZENER DIODE	1	
	D16313	BOECKP000047	DIODE	1	
	D16321	BOECKP000047	DIODE	1	
	D16324	MA3X152D0L	DIODE	1	
	D16331	BOEHP000003	DIODE	1	
	D16401	B0FBCN000005	DIODE	1	
	D16402	B0FBCN000005	DIODE	1	
	D16407	MA22D3900L	DIODE	1	
	D16421	MA3DF40000LW	ZENER DIODE	1	
	D16441	BOECKP000047	DIODE	1	
	D16451	BOECKP000047	DIODE	1	
	D16461	MA3DF46000LW	ZENER DIODE	1	
	D16466	MA2J11100L	DIODE	1	
	D16473	MA3X152D0L	DIODE	1	
	D16475	MAZ80510LL	ZENER DIODE	1	
	D16478	BOHCKS000002	DIODE	1	
	D16480	MA2J11100L	DIODE	1	
	D16481	B0FBCN000005	DIODE	1	
	D16497	BOECKP000047	DIODE	1	
	D16501	BOECKP000047	DIODE	1	
	D16503	BOECKP000047	DIODE	1	
	D16521	BOECKP000047	DIODE	1	
	D16522	BOECKP000047	DIODE	1	
	D16523	BOECKP000047	DIODE	1	
	D16583	LNJ301MPUJA	LED	1	
	D16585	MA2J11100L	DIODE	1	
	D16601	MA3X152E0L	ZENER DIODE	1	
	D16602	MAZ81500ML	ZENER DIODE	1	
	D16604	MA2J11100L	DIODE	1	
	D16605	MAZ80510LL	ZENER DIODE	1	
	D16606	BOECKM000038	DIODE	1	
	D16607	MA2J11100L	DIODE	1	
	D16608	MA8120M	ZENER DIODE	1	
	D16609	MA2J11100L	DIODE	1	
	D16610	MA2J11100L	DIODE	1	
	D16618	BOECKP000047	DIODE	1	
	D16619	BOECKP000047	DIODE	1	
	D16631	MAZ82400ML	DIODE	1	
	D16632	MAZ82400ML	DIODE	1	
	D16641	BOHCKS000002	DIODE	1	
	D16642	BOHCKS000002	DIODE	1	
	D16643	MA2J11100L	DIODE	1	
	D16644	BOHCKS000002	DIODE	1	
	D16659	BOHCKM000014	DIODE	1	
	D16660	BOHCMR000002	DIODE	1	
	D16661	MA2J11100L	DIODE	1	
	D16662	MA8330M	ZENER DIODE	1	
	D16663	MA8330M	ZENER DIODE	1	

Safety	Ref. No.	Part No.	Part Name & Description	Pcs	Remarks
	D16664	MA8330M	ZENER DIODE	1	
	D16665	MAZ80510LL	ZENER DIODE	1	
	D16667	MA2J11100L	DIODE	1	
	D16668	MA3X152D0L	DIODE	1	
	D16669	MA2J11100L	DIODE	1	
	D16670	BOHCMR000002	DIODE	1	
	D16671	MA2J11100L	DIODE	1	
	D16710	MAZ81500ML	ZENER DIODE	1	
	D16711	BOHCMR000002	DIODE	1	
	D16712	MAZ81500ML	ZENER DIODE	1	
	D16713	BOHCMR000002	DIODE	1	
	D16714	MAZ81500ML	ZENER DIODE	1	
	D16715	BOHCMR000002	DIODE	1	
	D16717	MA8330M	ZENER DIODE	1	
	D16718	MA2J11100L	DIODE	1	
	D16719	BOECKP000047	DIODE	1	
	D16720	BOECKP000047	DIODE	1	
	D16721	BOHCKS000002	DIODE	1	
	D16722	MA2J11100L	DIODE	1	
	D16725	MA2J11100L	DIODE	1	
	D16761	MA2J11100L	DIODE	1	
	D16763	BOECKP000047	DIODE	1	
	D16764	BOHCKS000002	DIODE	1	
	D16765	BOECKP000047	DIODE	1	
	D16766	BOECKP000047	DIODE	1	
	D16771	MAZ80510LL	ZENER DIODE	1	
	D16816	MAZ80680HL	ZENER DIODE	1	
	D16817	MAZ80680HL	ZENER DIODE	1	
	D16820	MA3X152E0L	ZENER DIODE	1	
	D16821	MAZ82000ML	ZENER DIODE	1	
	D16822	MA2J11100L	DIODE	1	
	D16824	MA8330M	ZENER DIODE	1	
	D16825	MA8330M	ZENER DIODE	1	
	D16830	MA8056H	ZENER DIODE	1	
	D16836	MAZ81500ML	ZENER DIODE	1	
	D16837	MA2J11100L	DIODE	1	
	D16838	B0BC027A0234	ZENER DIODE	1	
	D16839	BOECKP000047	DIODE	1	
	D16859	BOHCKS000002	DIODE	1	
	D16860	BOHCKS000002	DIODE	1	
	D16861	MA8330M	ZENER DIODE	1	
	D16862	MA8330M	ZENER DIODE	1	
	D16871	MAZ82400ML	DIODE	1	
	D16873	MAZ82000ML	ZENER DIODE	1	
	D16874	MAZ80510LL	ZENER DIODE	1	
	D16875	MA2J11100L	DIODE	1	
	FL3001	JOHABB000003	LC FILTER	1	
	FL3002	JOHABB000003	LC FILTER	1	
	FL3003	JOHABB000004	LC FILTER	1	
	FL3004	JOHABB000004	LC FILTER	1	
	FL3005	JOHABB000004	LC FILTER	1	
	FL3008	JOHABB000003	LC FILTER	1	
	FL3011	JOHABB000003	LC FILTER	1	
	FL3012	JOHABB000003	LC FILTER	1	
	FL3013	JOHABB000003	LC FILTER	1	
	FL3014	JOHABB000003	LC FILTER	1	
	FL3710	JOZZA0000091	FILTER	1	
	FL3711	JOZZA0000091	FILTER	1	
	FL3712	JOZZA0000091	FILTER	1	
	FL3713	JOZZA0000091	FILTER	1	
	FL3714	JOZZA0000091	FILTER	1	
	FL5510	F1J1E104A148	C 0.10UF, Z, 25V	1	
	FL5511	F1J1E104A148	C 0.10UF, Z, 25V	1	
	FL8801	JOHAAA000013	LC FILTER	1	
	FL8802	JOHAAA000013	LC FILTER	1	
	FL9300	F1J1E104A148	C 0.10UF, Z, 25V	1	
	FL9301	F1J1E104A148	C 0.10UF, Z, 25V	1	
	G51	K1KY16BA0192	16P CONNECTOR	1	
	GS52	K1KA12A00317	12P CONNECTOR	1	

Safety	Ref. No.	Part No.	Part Name & Description	Pcs	Remarks
	IC1100	MNZSFG3GP53	IC	1	
	IC1101	TVRP930	IC	1	
	IC1102	C0JBAZ002261	IC	1	
	IC2008	C0CBCBE00001	IC	1	
	IC2012	C1BB00000947	IC	1	
	IC2013	C0DBGYY00281	IC	1	
	IC2106	C1AB00002909	IC	1	
	IC2107	C0DBFFD00003	IC	1	
	IC2301	C1AB00002875	IC	1	
	IC2403	C1AB00002877	IC	1	
	IC3001	C1AB00002855	IC	1	
	IC4510	C1AB00002966	IC	1	
	IC4511	C0CBCBE00001	IC	1	
	IC4512	C0DBGYY00477	IC	1	
	IC4513	C0DBGYY00477	IC	1	
	IC4514	C0JBAZ002301	IC	1	
	IC4515	C0JBAZ002301	IC	1	
	IC4800	C1ZBZ0003775	IC	1	
	IC4811	C0JBAZ002060	IC	1	
	IC5400	C0DBAYY00183	IC	1	
	IC5401	C0DBAYY00183	IC	1	
	IC5600	C0DBAYY00273	IC	1	
	IC5601	C0DBAYY00274	IC	1	
	IC5660	C0EBM0000026	IC	1	
	IC8001	MN2WS0047	IC	1	
	IC8002	C3ABRY000015	IC	1	
	IC8003	C3ABRY000015	IC	1	
	IC8004	COZBZ0001567	IC	1	
	IC8554	TVRP798-2	IC	1	PAVCSG
	IC8601	TVRP956	IC	1	PAVCSG D/H/HM/ M/MR/MT
	IC8601	TVRP964	IC	1	PAVCSG MS
	IC9001	TVRP934-3	IC	1	
	IC9002	C1ZBZ0003577	IC	1	
	IC9003	MNZSFG4GPH3	IC	1	
	IC9011	C0EBF0000431	IC	1	
	IC9013	C0JBAZ002301	IC	1	
	IC9303	TVRP938-1	IC	1	
	IC9500	C1ZBZ0003759	IC	1	
	IC9802	C0JBAZ001120	IC	1	
	IC9803	C0JBAZ001120	IC	1	
	IC9805	C0DBAYY00274	IC	1	
	IC9806	C0DBAYY00273	IC	1	
	IC9900	MN84526	IC	1	
	IC9901	C3ABQY000032	IC	1	
	IC14901	AN16082A-VT	IC	1	
	IC14902	AN16082A-VT	IC	1	
	IC14903	AN16082A-VT	IC	1	
	IC14904	AN16082A-VT	IC	1	
	IC14905	AN16082A-VT	IC	1	
	IC14906	AN16082A-VT	IC	1	
	IC14951	AN16082A-VT	IC	1	
	IC14952	AN16082A-VT	IC	1	
	IC14953	AN16082A-VT	IC	1	
	IC14954	AN16082A-VT	IC	1	
	IC14955	AN16082A-VT	IC	1	
	IC14956	AN16082A-VT	IC	1	
	IC14961	C0JBAZ000994	IC	1	
	IC14962	C0JBAZ000994	IC	1	
	IC14963	C0JBAA000377	IC	1	
	IC16131	COZBZ0000895	IC	1	
	IC16151	COZBZ0001324	IC	1	
	IC16191	COZBZ0000895	IC	1	
	IC16241	C0JBAZ002811	IC	1	
	IC16251	COBBBA000024	IC	1	
	IC16301	MIP9L02MBS	IC	1	
	IC16302	C0CBALC00012	IC	1	
	IC16303	C0JBAC000363	IC	1	
	IC16471	C0DBEKA00003	IC	1	
	IC16472	C0JBAA000377	IC	1	
	IC16501	COZBZ0000895	IC	1	
	IC16521	COZBZ0001324	IC	1	

Safety	Ref. No.	Part No.	Part Name & Description	Pcs	Remarks
	IC16561	C0JBAZ002811	IC	1	
	IC16562	C0JBAZ002811	IC	1	
	IC16581	COBBBA000024	IC	1	
	IC16724	C0CBADC00072	IC	1	
	IC16725	C0CBADC00072	IC	1	
	IC16752	COZBZ0001324	IC	1	
	IC16772	COZBZ0001325	IC	1	
	IC16784	MIP9L02MBS	IC	1	
	IC16786	MIP9L02MBS	IC	1	
	IC16787	C0DBEYY00078	IC	1	
	IC16788	MIP9L02MBS	IC	1	
	IC16789	C0DBEYY00078	IC	1	
	IC16791	NOBF1FB00002	IC	1	
	IC17101	C0JBAZ001120	IC	1	
	IC17102	C0JBAZ001120	IC	1	
	IC17201	C0JBAZ001120	IC	1	
	IC17202	C0JBAZ001120	IC	1	
	IC17203	C0JBAZ001120	IC	1	
	JA3701	DOGDR00Z0002	M 0 OHM, 1/10W	1	
	JA3702	DOGDR00Z0002	M 0 OHM, 1/10W	1	
	JA3703	DOGDR00Z0002	M 0 OHM, 1/10W	1	
	JA3704	DOGDR00Z0002	M 0 OHM, 1/10W	1	
	JA3705	DOGDR00Z0002	M 0 OHM, 1/10W	1	
	JA3706	DOGDR00Z0002	M 0 OHM, 1/10W	1	
	JA3707	DOGDR00Z0002	M 0 OHM, 1/10W	1	
	JA3751	ERJ8GEY0R00	M 0 OHM, 1/8W	1	
	JA3753	ERJ8GEY0R00	M 0 OHM, 1/8W	1	
	JA3754	ERJ8GEY0R00	M 0 OHM, 1/8W	1	
	JA3755	ERJ8GEY0R00	M 0 OHM, 1/8W	1	
	JA3756	ERJ8GEY0R00	M 0 OHM, 1/8W	1	
	JA3757	ERJ8GEY0R00	M 0 OHM, 1/8W	1	
	JA3758	ERJ8GEY0R00	M 0 OHM, 1/8W	1	
	JA3759	ERJ8GEY0R00	M 0 OHM, 1/8W	1	
	JA3760	ERJ8GEY0R00	M 0 OHM, 1/8W	1	
	JA3761	ERJ8GEY0R00	M 0 OHM, 1/8W	1	
	JK3001	K1FB315A0006	CONNECTOR	1	
	JK3100	K1U932A00002	CONNECTOR	1	
	JK3701	K4AK18B00007	TERMINAL	1	
	JK4500	K1FY119D0003	CONNECTOR	1	
	JK4501	K1FY119D0003	CONNECTOR	1	
	JK7701	K1NA09D00004	9P CONNECTOR	1	
	JS2059	DOYAR0000007	M 0 OHM 1/4W	1	
	JS2060	DOYAR0000007	M 0 OHM 1/4W	1	
	JS2061	DOYAR0000007	M 0 OHM 1/4W	1	
	JS2062	DOYAR0000007	M 0 OHM 1/4W	1	
	JS3003	DOYAR0000007	M 0 OHM 1/4W	1	
	JS3704	DOGDR00Z0002	M 0 OHM, 1/10W	1	
	JS3705	DOGDR00Z0002	M 0 OHM, 1/10W	1	
	JS3707	DOGDR00Z0002	M 0 OHM, 1/10W	1	
	JS3708	DOGDR00Z0002	M 0 OHM, 1/10W	1	
	JS3712	DOGDR00Z0002	M 0 OHM, 1/10W	1	
	JS3713	DOGDR00Z0002	M 0 OHM, 1/10W	1	
	JS7701	DOGDR00Z0002	M 0 OHM J 1/16W	1	
	K1	K1KA11B00092	11P CONNECTOR	1	
	L1100	J0JYC0000068	CHIP INDUCTOR	1	
	L2001	G1C150KA0038	INDUCTION COIL	1	
	L2005	J0JCC0000284	CHIP INDUCTOR	1	
	L2006	J0JCC0000284	CHIP INDUCTOR	1	
	L2010	G1C220MA0291	INDUCTION COIL	1	
	L2012	G1C220MA0291	INDUCTION COIL	1	
	L2014	G1C220MA0291	INDUCTION COIL	1	
	L2016	G1C220MA0291	INDUCTION COIL	1	
	L2018	J0JHC0000042	CHIP INDUCTOR	1	
	L2021	G1C470MA0291	INDUCTION COIL	1	
	L2022	G1C100MA0072	INDUCTION COIL	1	
	L2023	G1C3R0ZA0156	INDUCTION COIL	1	
	L2025	J0JCC0000269	CHIP INDUCTOR	1	
	L2026	J0JCC0000269	CHIP INDUCTOR	1	

Safety	Ref. No.	Part No.	Part Name & Description	Pcs	Remarks
	L2028	J0JYC0000068	CHIP INDUCTOR	1	
	L2030	J0JYC0000068	CHIP INDUCTOR	1	
	L2031	J0JYC0000068	CHIP INDUCTOR	1	
	L2032	J0JYC0000068	CHIP INDUCTOR	1	
	L2033	J0JCC0000269	CHIP INDUCTOR	1	
	L2034	J0JCC0000269	CHIP INDUCTOR	1	
	L2300	J0JYC0000068	CHIP INDUCTOR	1	
	L3002	J0JCC0000100	CHIP INDUCTOR	1	
	L3003	J0JCC0000100	CHIP INDUCTOR	1	
	L3006	J0JCC0000100	CHIP INDUCTOR	1	
	L3007	J0JCC0000100	CHIP INDUCTOR	1	
	L3010	J0JCC0000100	CHIP INDUCTOR	1	
	L3011	J0JCC0000100	CHIP INDUCTOR	1	
	L3014	J0JCC0000100	CHIP INDUCTOR	1	
	L3015	J0JCC0000100	CHIP INDUCTOR	1	
	L3017	J0JCC0000100	CHIP INDUCTOR	1	
	L3018	J0JCC0000100	CHIP INDUCTOR	1	
	L3019	J0JCC0000100	CHIP INDUCTOR	1	
	L3023	J0JCC0000100	CHIP INDUCTOR	1	
	L3024	J0JCC0000100	CHIP INDUCTOR	1	
	L3700	J0JCC0000364	CHIP INDUCTOR	1	
	L3701	J0JCC0000364	CHIP INDUCTOR	1	
	L3707	J0JCC0000100	CHIP INDUCTOR	1	
	L3708	J0JCC0000100	CHIP INDUCTOR	1	
	L4502	J0JYC0000068	CHIP INDUCTOR	1	
	L4503	J0JYC0000068	CHIP INDUCTOR	1	
	L4504	J0JYC0000068	CHIP INDUCTOR	1	
	L4505	J0JYC0000068	CHIP INDUCTOR	1	
	L4506	J0JYC0000068	CHIP INDUCTOR	1	
	L4507	J0JYC0000068	CHIP INDUCTOR	1	
	L4511	J0JYC0000068	CHIP INDUCTOR	1	
	L4512	J0JCC0000241	CHIP INDUCTOR	1	
	L4513	J0JCC0000241	CHIP INDUCTOR	1	
	L4514	J0JYC0000068	CHIP INDUCTOR	1	
	L4515	J0JYC0000068	CHIP INDUCTOR	1	
	L4516	J0JYC0000068	CHIP INDUCTOR	1	
	L4517	J0JYC0000068	CHIP INDUCTOR	1	
	L4518	J0JYC0000068	CHIP INDUCTOR	1	
	L4519	J0JYC0000068	CHIP INDUCTOR	1	
	L5401	G1C330M00027	INDUCTION COIL	1	
	L5405	G1C330M00027	INDUCTION COIL	1	
	L5407	J0JYC0000068	CHIP INDUCTOR	1	
	L5600	G1C2R2Z00007	INDUCTION COIL	1	
	L5601	G1C2R2Z00007	INDUCTION COIL	1	
	L5602	G1C4R7Z00014	INDUCTION COIL	1	
	L5604	G1C100MA0203	INDUCTION COIL	1	
	L5605	J0JHC0000075	CHIP INDUCTOR	1	
	L5606	G1C100MA0077	INDUCTION COIL	1	
	L5690	J0JYC0000068	CHIP INDUCTOR	1	
	L5691	J0JYC0000068	CHIP INDUCTOR	1	
	L7721	J0JCC0000143	CHIP INDUCTOR	1	
	L8001	J0JHC0000045	CHIP INDUCTOR	1	
	L8002	J0JHC0000045	CHIP INDUCTOR	1	
	L8003	J0JHC0000045	CHIP INDUCTOR	1	
	L8004	J0JHC0000045	CHIP INDUCTOR	1	
	L8005	J0JHC0000045	CHIP INDUCTOR	1	
	L8007	J0JHC0000045	CHIP INDUCTOR	1	
	L8008	J0JHC0000045	CHIP INDUCTOR	1	
	L8009	J0JHC0000045	CHIP INDUCTOR	1	
	L8010	J0JHC0000045	CHIP INDUCTOR	1	
	L8551	J0JHC0000075	CHIP INDUCTOR	1	
	L8801	J0JHC0000045	CHIP INDUCTOR	1	
	L9076	J0JYC0000068	CHIP INDUCTOR	1	
	L9800	G1C2R2Z00007	INDUCTION COIL	1	
	L9801	G1C1R5Z00006	INDUCTION COIL	1	
	L9802	G1C2R2Z00007	INDUCTION COIL	1	
	L9900	J0JHC0000078	CHIP INDUCTOR	1	
	L9901	J0JHC0000078	CHIP INDUCTOR	1	
	L9902	D0GBR00Z0002	M 0 OHM J 1/16W	1	
	L9903	J0JHC0000078	CHIP INDUCTOR	1	
	L16001	G0C2R1KA0190	PEAKING COIL	1	
	L16002	G0C2R1KA0190	PEAKING COIL	1	
	L16003	G0C2R1KA0190	PEAKING COIL	1	

Safety	Ref. No.	Part No.	Part Name & Description	Pcs	Remarks
	L16011	G0C2R1KA0190	PEAKING COIL	1	
	L16012	G0C2R1KA0190	PEAKING COIL	1	
	L16013	G0C2R1KA0190	PEAKING COIL	1	
	L16102	J0JCC0000015	CHIP INDUCTOR	1	
	L16103	G0ZZ00002183	PEAKING COIL	1	
	L16221	G0ZZ00002183	PEAKING COIL	1	
	L16262	G0ZZ00002183	PEAKING COIL	1	
	L16271	G0ZZ00002183	PEAKING COIL	1	
	L16301	J0JHC0000031	CHIP INDUCTOR	1	
	L16398	J0JCC0000015	CHIP INDUCTOR	1	
	L16399	J0JCC0000015	CHIP INDUCTOR	1	
	L16401	G0C2R1KA0190	PEAKING COIL	1	
	L16402	G0C2R1KA0190	PEAKING COIL	1	
	L16403	G0C2R1KA0190	PEAKING COIL	1	
	L16411	G0C2R1KA0190	PEAKING COIL	1	
	L16412	G0C2R1KA0190	PEAKING COIL	1	
	L16413	G0C2R1KA0190	PEAKING COIL	1	
	L16472	G0ZZ00002183	PEAKING COIL	1	
	L16591	G0ZZ00002183	PEAKING COIL	1	
	L16697	G0C102KA0187	PEAKING COIL	1	
	L16698	G0C681KA0187	PEAKING COIL	1	
	L16699	G0C331KA0187	PEAKING COIL	1	
	L16801	G0ZZ00002183	PEAKING COIL	1	
	PA5510	K5H4022A0023	FUSE	1	
	PA5600	K5H5022A0023	FUSE	1	
	PA9900	K5H5022A0023	FUSE	1	
	PC14951	B3PBA0000457	IC	1	
	PC14952	B3PBA0000457	IC	1	
	PC16480	B3PBA0000223	IC	1	
	PC16601	B3PBA0000223	IC	1	
	PC16602	B3PBA0000443	IC	1	
	PC16603	B3PBA0000223	IC	1	
	PC16705	B3PBA0000456	IC	1	
	PC16710	B3PBA0000223	IC	1	
	PC16896	B3PBA0000223	IC	1	
	PC16897	B3PBA0000223	IC	1	
△	PCB	TZTNP01RWTM	CIRCUIT BOARD A	1	PAVCSG D/H/HM/M/MR/MT
△	PCB	TZTNP01RWTQ	CIRCUIT BOARD A	1	PAVCSG MS
△	PCB	TXNGS1RWTM	CIRCUIT BOARD GS	1	PAVCSG
△	PCB	LSEP1260MTHB	CIRCUIT BOARD P	1	PAVCSG D/H/HM/MT
△	PCB	LSEP1260MMHB	CIRCUIT BOARD P	1	PAVCSG M/MR/MS
△	PCB	TXNC11RRTM	CIRCUIT BOARD C1	1	PAVCSG
△	PCB	TXNC21RRTM	CIRCUIT BOARD C2	1	PAVCSG
△	PCB	TXNSC1RRTM	CIRCUIT BOARD SC	1	PAVCSG
△	PCB	TXNSD1RRTM	CIRCUIT BOARD SD	1	PAVCSG
△	PCB	TXNSS1RRTM	CIRCUIT BOARD SS	1	PAVCSG
△	PCB	TXNSU1RRTM	CIRCUIT BOARD SU	1	PAVCSG
△	PCB	TXN/G1RRTM	CIRCUIT BOARD G	1	PAVCSG
△	PCB	TXN/K1RWTM	CIRCUIT BOARD K	1	PAVCSG
△	PCB	TXN/S1RRTM	CIRCUIT BOARD S	1	PAVCSG
	Q2001	2SD0601ARL	TRANSISTOR	1	
	Q2022	2SB0709ARL	TRANSISTOR	1	
	Q2027	B1CFNG000001	FET	1	
	Q2028	B1CBHD000002	FET	1	
	Q2029	B1CBHD000002	FET	1	
	Q2030	2SB0709ARL	TRANSISTOR	1	
	Q2033	2SB0709ARL	TRANSISTOR	1	
	Q2510	2SD0601ARL	TRANSISTOR	1	
	Q2511	2SD0601ARL	TRANSISTOR	1	
	Q2513	2SD0601ARL	TRANSISTOR	1	
	Q3000	2SD0601ARL	TRANSISTOR	1	
	Q3001	2SD0601ARL	TRANSISTOR	1	
	Q4500	2SD0601ARL	TRANSISTOR	1	

Safety	Ref. No.	Part No.	Part Name & Description	Pcs	Remarks
	Q4501	2SD0601ARL	TRANSISTOR	1	
	Q4502	2SD0601ARL	TRANSISTOR	1	
	Q4503	2SD0601ARL	TRANSISTOR	1	
	Q4514	2SB0709ARL	TRANSISTOR	1	
	Q4515	2SB0709ARL	TRANSISTOR	1	
	Q4516	2SB0709ARL	TRANSISTOR	1	
	Q4517	2SB0709ARL	TRANSISTOR	1	
	Q4811	2SD0601ASL	TRANSISTOR	1	
	Q5522	2SB0709ARL	TRANSISTOR	1	
	Q5600	B1MBEDA00015	FET	1	
	Q5601	B1MBDDA00003	FET	1	
	Q5602	B1MBDDA00003	FET	1	
	Q5606	2SD0601ARL	TRANSISTOR	1	
	Q5607	2SD0601ARL	TRANSISTOR	1	
	Q9010	2SD0601ARL	TRANSISTOR	1	
	Q9044	2SD0601ARL	TRANSISTOR	1	
	Q9046	2SD0601ARL	TRANSISTOR	1	
	Q9057	2SD0601ARL	TRANSISTOR	1	
	Q9058	2SD0601ARL	TRANSISTOR	1	
	Q9301	2SD0601ARL	TRANSISTOR	1	
	Q9302	2SD0601ARL	TRANSISTOR	1	
	Q9805	2SD0601ARL	TRANSISTOR	1	
	Q9806	2SD0601ARL	TRANSISTOR	1	
	Q9807	B1MBDDA00003	FET	1	
	Q9808	B1MBDDA00015	FET	1	
	Q9809	B1MBDDA00003	FET	1	
	Q14961	2SD0601ARL	TRANSISTOR	1	
	Q14962	2SD0601ARL	TRANSISTOR	1	
	Q16001	B1JAEN000002	TRANSISTOR	1	
	Q16002	B1JAEN000002	TRANSISTOR	1	
	Q16021	B1JAEN000002	TRANSISTOR	1	
	Q16022	B1JAEN000002	TRANSISTOR	1	
	Q16041	B1JAEN000003	TRANSISTOR	1	
	Q16051	B1JADN000003	TRANSISTOR	1	
	Q16102	B1DFKM000002	FET	1	
	Q16141	B1HFPPA00001	TRANSISTOR	1	
	Q16161	B1HFPPA00001	TRANSISTOR	1	
	Q16171	B1ABRD000003	TRANSISTOR	1	
	Q16172	B1ADRD000001	TRANSISTOR	1	
	Q16181	B1ABRD000003	TRANSISTOR	1	
	Q16182	B1ADRD000001	TRANSISTOR	1	
	Q16191	B1HFPPA00001	TRANSISTOR	1	
	Q16251	2SD0601ARL	TRANSISTOR	1	
	Q16280	2SD0601ARL	TRANSISTOR	1	
	Q16301	B1CBGD000001	FET	1	
	Q16302	B1CFNG000001	FET	1	
	Q16304	2SB0709ARL	TRANSISTOR	1	
	Q16331	B1CERL000012	FET	1	
	Q16335	B1CERL000012	FET	1	
	Q16339	2SK417300L	FET	1	
	Q16401	B1JAEN000002	TRANSISTOR	1	
	Q16404	B1JAEN000002	TRANSISTOR	1	
	Q16421	B1JAEP000002	TRANSISTOR	1	
	Q16422	B1JAEP000002	TRANSISTOR	1	
	Q16441	B1JAEN000003	TRANSISTOR	1	
	Q16451	B1JADP000003	TRANSISTOR	1	
	Q16471	B1ABCF000231	TRANSISTOR	1	
	Q16501	B1HFPPA00001	TRANSISTOR	1	
	Q16521	B1HFPPA00001	TRANSISTOR	1	
	Q16531	B1ABRD000003	TRANSISTOR	1	
	Q16532	B1ADRD000001	TRANSISTOR	1	
	Q16551	B1ABRD000003	TRANSISTOR	1	
	Q16552	B1ADRD000001	TRANSISTOR	1	
	Q16581	B1ABCF000231	TRANSISTOR	1	
	Q16601	B1CERR000025	FET	1	
	Q16602	2SD0601AQL	TRANSISTOR	1	
	Q16603	2SB0709ARL	TRANSISTOR	1	
	Q16604	B1CHPM000001	FET	1	
	Q16605	2SB0709ARL	TRANSISTOR	1	
	Q16606	2SD0601AQL	TRANSISTOR	1	
	Q16607	B1CBGD000001	FET	1	
	Q16608	B1ABCF000231	TRANSISTOR	1	
	Q16622	2SK399500L	FET	1	

Safety	Ref. No.	Part No.	Part Name & Description	Pcs	Remarks
	Q16623	2SK399500L	FET	1	
	Q16642	2SK4175000LZ	FET	1	
	Q16643	2SK4175000LZ	FET	1	
	Q16645	2SK4175000LZ	FET	1	
	Q16661	B1JAER000003	TRANSISTOR	1	
	Q16662	2SD0601AQL	TRANSISTOR	1	
	Q16663	2SB0709ARL	TRANSISTOR	1	
	Q16664	B1HFPPA00001	TRANSISTOR	1	
	Q16665	B1ABCF000231	TRANSISTOR	1	
	Q16762	B1ADNF000006	TRANSISTOR	1	
	Q16781	B1HFPPA00001	TRANSISTOR	1	
	Q16805	2SC3063000RL	TRANSISTOR	1	
	Q16806	2SC1473AEA	TRANSISTOR	1	
	Q16814	B1ABCN000007	TRANSISTOR	1	
	Q16815	B1ABCN000007	TRANSISTOR	1	
	Q16816	2SD0601AQL	TRANSISTOR	1	
	Q16817	2SD0601AQL	TRANSISTOR	1	
	Q16871	2SB0709ARL	TRANSISTOR	1	
	Q16872	2SB0709ARL	TRANSISTOR	1	
	Q16873	B1ABCF000231	TRANSISTOR	1	
	Q16874	B1CBGD000001	FET	1	
	Q16875	B1ABCF000231	TRANSISTOR	1	
	Q16876	B1ABCF000231	TRANSISTOR	1	
	Q16879	B1ABCF000231	TRANSISTOR	1	
	R003	ERJ2GEJ103	M 10KOHM, J, 0.063W	1	
	R006	ERJ2GEJ103	M 10KOHM, J, 0.063W	1	
	R007	ERJ2GEJ103	M 10KOHM, J, 0.063W	1	
	R008	ERJ2GEJ103	M 10KOHM, J, 0.063W	1	
	R009	ERJ2GEJ103	M 10KOHM, J, 0.063W	1	
	R1013	ERJ2GEJ473	M 47KOHM, J, 0.063W	1	
	R1014	ERJ2GEJ473	M 47KOHM, J, 0.063W	1	
	R1100	ERJ2GEJ101	M 100 OHM, J, 0.063W	1	
	R1101	ERJ2GEJ101	M 100 OHM, J, 0.063W	1	
	R1102	ERJ2GEJ101	M 100 OHM, J, 0.063W	1	
	R1103	ERJ2RKD330	M 33 OHM, J, 2W	1	
	R1104	ERJ2GEJ473	M 47KOHM, J, 0.063W	1	
	R1105	ERJ2GEJ101	M 100 OHM, J, 0.063W	1	
	R1106	ERJ2GEJ101	M 100 OHM, J, 0.063W	1	
	R1107	ERJ2GEJ101	M 100 OHM, J, 0.063W	1	
	R1108	ERJ2GEJ101	M 100 OHM, J, 0.063W	1	
	R1109	ERJ2GEJ101	M 100 OHM, J, 0.063W	1	
	R1140	ERJ2GEJ473	M 47KOHM, J, 0.063W	1	
	R1153	ERJ2GEJ821	M 820 OHM, J, 0.063W	1	
	R1164	ERJ2GEJ103	M 10KOHM, J, 0.063W	1	
	R1166	ERJ2GEJ104	M 100KOHM, J, 0.063W	1	
	R1169	ERJ2GEJ683	M 68KOHM, J, 0.063W	1	
	R1170	ERJ2GEJ333	M 33KOHM, J, 0.063W	1	
	R1171	ERJ2GEJ683	M 68KOHM, J, 0.063W	1	
	R1172	ERJ2GEJ333	M 33KOHM, J, 0.063W	1	
	R1182	ERJ2GED273X	M 27KOHM, J, 0.063W	1	
	R1194	ERJ2GEJ683	M 68KOHM, J, 0.063W	1	



Safety	Ref. No.	Part No.	Part Name & Description	Pcs	Remarks
	R1196	ERJ2GEJ473	M 47KOHM, J, 0.063W	1	
	R1197	ERJ2GEJ103	M 10KOHM, J, 0.063W	1	
	R1200	ERJ2GEJ472	M 4.7KOHM, J, 0.063W	1	
	R1201	ERJ2GEJ472	M 4.7KOHM, J, 0.063W	1	
	R1203	ERJ2GEJ473	M 47KOHM, J, 0.063W	1	
	R1204	ERJ2RKD330	M 33 OHM, J, 2W	1	
	R1207	ERJ2GEJ101	M 100 OHM, J, 0.063W	1	
	R1208	ERJ2GEJ103	M 10KOHM, J, 0.063W	1	
	R1209	ERJ2GEJ473	M 47KOHM, J, 0.063W	1	
	R1210	ERJ2GEJ473	M 47KOHM, J, 0.063W	1	
	R1211	ERJ2GEJ473	M 47KOHM, J, 0.063W	1	
	R1212	ERJ2GEJ473	M 47KOHM, J, 0.063W	1	
	R1216	ERJ2GEJ103	M 10KOHM, J, 0.063W	1	
	R1217	ERJ2GEJ104	M 100KOHM, J, 0.063W	1	
	R1218	ERJ2GEJ103	M 10KOHM, J, 0.063W	1	
	R1219	ERJ2GEJ103	M 10KOHM, J, 0.063W	1	
	R1220	ERJ2GEJ103	M 10KOHM, J, 0.063W	1	
	R1221	D1BB7151A055	M7.15KOHM, 1/10W	1	
	R1224	ERJ2GEJ103	M 10KOHM, J, 0.063W	1	
	R1225	ERJ2GEJ103	M 10KOHM, J, 0.063W	1	
	R1230	ERJ2GEJ473	M 47KOHM, J, 0.063W	1	
	R1236	ERJ2GEJ473	M 47KOHM, J, 0.063W	1	
	R1237	ERJ2GEJ102X	M 1K OHM J 1/4W	1	
	R1243	ERJ2GEJ473	M 47KOHM, J, 0.063W	1	
	R1251	ERJ2GEJ473	M 47KOHM, J, 0.063W	1	
	R1255	ERJ2GEJ102X	M 1K OHM J 1/4W	1	
	R2000	ERJ2GEJ220	M 22 OHM, J, 0.063W	1	
	R2001	ERJ2GEJ220	M 22 OHM, J, 0.063W	1	
	R2002	ERJ2GEJ681	M 680 OHM, J, 0.063W	1	
	R2003	ERJ2GEJ105	M 1MOHM, J, 0.063W	1	
	R2006	ERJ2GEJ471	M 470 OHM, J, 0.063W	1	
	R2007	ERJ2GEJ221	M 220 OHM, J, 0.063W	1	
	R2008	ERJ2GEJ471	M 470 OHM, J, 0.063W	1	
	R2015	ERJ2GEJ103	M 10KOHM, J, 0.063W	1	
	R2016	ERJ2GEJ103	M 10KOHM, J, 0.063W	1	
	R2017	ERJ2GEJ103	M 10KOHM, J, 0.063W	1	
	R2018	ERJ2GEJ103	M 10KOHM, J, 0.063W	1	
	R2019	D1BB2002A055	M 20KOHM, 1/10W	1	
	R2020	D1BB2001A055	M 2KOHM, 1/10W	1	
	R2023	ERJ2GEJ103	M 10KOHM, J, 0.063W	1	
	R2026	D1BB1203A055	M 120KOHM, 1/10W	1	
	R2027	D1BB7502A055	M 75KOHM, 1/10W	1	
	R2047	D1BB2002A055	M 20KOHM, 1/10W	1	
	R2048	D1BB2002A055	M 20KOHM, 1/10W	1	
	R2050	D1BB2002A055	M 20KOHM, 1/10W	1	

Safety	Ref. No.	Part No.	Part Name & Description	Pcs	Remarks
	R2051	D1BB2002A055	M 20KOHM, 1/10W	1	
	R2052	ERJ6GEYJ331V	M 330 OHM J 1/10W	1	
	R2053	ERJ2GEJ223	M 22KOHM, J, 0.063W	1	
	R2054	ERJ2GEJ103	M 10KOHM, J, 0.063W	1	
	R2057	ERJ2GEJ102X	M 1K OHM J 1/4W	1	
	R2058	ERJ2GEJ103	M 10KOHM, J, 0.063W	1	
	R2063	ERJ2GEJ101	M 100 OHM, J, 0.063W	1	
	R2064	ERJ2GEJ101	M 100 OHM, J, 0.063W	1	
	R2065	ERJ2GEJ823	M 82KOHM, J, 0.063W	1	
	R2071	ERJ2GEJ104	M 100KOHM, J, 0.063W	1	
	R2072	ERJ2GEJ104	M 100KOHM, J, 0.063W	1	
	R2073	ERJ6GEYG681	M 680 OHM, J, 1/10W	1	
	R2074	D1BB6802A055	M 68KOHM, 1/10W	1	
	R2075	D1BB1583A055	M 158KOHM, 1/10W	1	
	R2089	ERJ2GEJ153	M 15KOHM, J, 0.063W	1	
	R2090	ERJ2GEJ153	M 15KOHM, J, 0.063W	1	
	R2092	ERJ2GEJ103	M 10KOHM, J, 0.063W	1	
	R2093	ERJ2GEJ103	M 10KOHM, J, 0.063W	1	
	R2095	ERJ2GEJ473	M 47KOHM, J, 0.063W	1	
	R2096	ERJ2GEJ473	M 47KOHM, J, 0.063W	1	
	R2097	ERJ2GEJ105	M 1MOHM, J, 0.063W	1	
	R2098	ERJ2GEJ103	M 10KOHM, J, 0.063W	1	
	R2111	ERJ2GEJ103	M 10KOHM, J, 0.063W	1	
	R2114	ERJ2GEJ222	M 2.2KOHM, J, 0.063W	1	
	R2115	ERJ2GEJ222	M 2.2KOHM, J, 0.063W	1	
	R2118	ERJ2GEJ471	M 470 OHM, J, 0.063W	1	
	R2121	ERJ8GEYJ3R3V	M 3.3 OHM, J, 1/8W	1	
	R2123	ERJ8GEYJ3R3V	M 3.3 OHM, J, 1/8W	1	
	R2125	ERJ8GEYJ3R3V	M 3.3 OHM, J, 1/8W	1	
	R2127	ERJ8GEYJ3R3V	M 3.3 OHM, J, 1/8W	1	
	R2129	ERJ2GEJ100	M 10 OHM, J, 0.063W	1	
	R2132	ERJ2GEJ471	M 470 OHM, J, 0.063W	1	
	R2133	ERJ2GEJ100	M 10 OHM, J, 0.063W	1	
	R2137	ERJ2GEJ100	M 10 OHM, J, 0.063W	1	
	R2141	ERJ2GEJ102X	M 1K OHM J 1/4W	1	
	R2142	ERJ2GEJ222	M 2.2KOHM, J, 0.063W	1	
	R2146	DOYAR0000007	M 0 OHM 1/4W	1	
	R2147	DOYAR0000007	M 0 OHM 1/4W	1	
	R2148	ERJ2GEJ752X	M 7.5KOHM, J, 0.063W	1	
	R2149	ERJ2GEJ752X	M 7.5KOHM, J, 0.063W	1	
	R2164	D1BB1003A055	M 100KOHM, 1/10W	1	
	R2165	D1BB3401A055	M 3.4KOHM, 1/10W	1	
	R2172	ERJ2GEJ680	M 68 OHM, J, 0.063W	1	
	R2174	ERJ2GEJ221	M 220 OHM, J, 0.063W	1	

Safety	Ref. No.	Part No.	Part Name & Description	Pcs	Remarks
	R2175	ERJ2GEJ561	M 60 OHM, J, 0.063W	1	
	R2176	ERJ6GEYJ271V	M 270 OHM J 1/10W	1	
	R2177	DOGBR00Z0002	M 0 OHM J 1/16W	1	
	R2178	DOGBR00Z0002	M 0 OHM J 1/16W	1	
	R2179	ERJ2GEJ221	M 220 OHM, J, 0.063W	1	
	R2180	ERJ2GEJ473	M 47KOHM, J, 0.063W	1	
	R2193	DOYAR0000007	M 0 OHM 1/4W	1	
	R2200	ERJ6GEYJ153V	M 15KOHM, J, 1/10W	1	
	R2211	ERJ2GEJ102X	M 1K OHM J 1/4W	1	
	R2271	EXB28V220J	RESISTOR ARRAY	1	
	R2300	D1BB4701A055	M 4.7KOHM, 1/10W	1	
	R2506	ERJ6GEYOR00V	M 0 OHM J 1/10W	1	
	R2507	ERJ6GEYOR00V	M 0 OHM J 1/10W	1	
	R2516	ERJ3GEYJ223	M 22KOHM, J, 1/16W	1	
	R2517	ERJ3GEYJ470	M 47 OHM, J, 1/16W	1	
	R2520	ERJ3GEYJ224	M 220KOHM, J, 1/16W	1	
	R2524	ERJ3GEYJ223	M 22KOHM, J, 1/16W	1	
	R2525	D1BB5760A055	M 576 OHM, 1/10W	1	
	R2530	DOGB473JA057	M 47KOHM, J, 1/16W	1	
	R2531	D1BB2700A055	M 270 OHM, 1/10W	1	
	R2542	DOGB473JA057	M 47KOHM, J, 1/16W	1	
	R2556	DOGB103JA041	M 10K OHM J 1/16W	1	
	R2557	ERJ3GEYJ223	M 22KOHM, J, 1/16W	1	
	R2576	JOJCC0000269	CHIP INDUCTOR	1	
	R2577	JOJCC0000269	CHIP INDUCTOR	1	
	R2579	DOGBR00Z0002	M 0 OHM J 1/16W	1	
	R3000	ERJ6GEYJ223	M 22KOHM, J, 1/10W	1	
	R3001	ERJ6GEYJ223	M 22KOHM, J, 1/10W	1	
	R3002	ERJ6GEYJ223	M 22KOHM, J, 1/10W	1	
	R3003	ERJ6GEYJ223	M 22KOHM, J, 1/10W	1	
	R3004	ERJ6GEYJ223	M 22KOHM, J, 1/10W	1	
	R3005	ERJ6GEYJ223	M 22KOHM, J, 1/10W	1	
	R3019	ERJ2GEJ222	M 2.2KOHM, J, 0.063W	1	
	R3021	ERJ2GEJ222	M 2.2KOHM, J, 0.063W	1	
	R3024	ERJ2GEJ104	M 100KOHM, J, 0.063W	1	
	R3025	ERJ2GEJ104	M 100KOHM, J, 0.063W	1	
	R3033	ERJ2GEJ221	M 220 OHM, J, 0.063W	1	
	R3034	ERJ2GEJ221	M 220 OHM, J, 0.063W	1	
	R3037	ERJ2GEJ221	M 220 OHM, J, 0.063W	1	
	R3038	ERJ2GEJ221	M 220 OHM, J, 0.063W	1	
	R3043	ERJ2GEJ221	M 220 OHM, J, 0.063W	1	
	R3045	ERJ2GEJ221	M 220 OHM, J, 0.063W	1	
	R3047	ERJ2GEJ221	M 220 OHM, J, 0.063W	1	
	R3048	ERJ2GEJ221	M 220 OHM, J, 0.063W	1	
	R3049	ERJ2GEJ221	M 220 OHM, J, 0.063W	1	
	R3050	ERJ2GEJ221	M 220 OHM, J, 0.063W	1	
	R3051	ERJ2GEJ221	M 220 OHM, J, 0.063W	1	
	R3052	ERJ2GEJ221	M 220 OHM, J, 0.063W	1	
	R3074	ERJ6RED750	M 75 OHM, 1/10W	1	
	R3075	ERJ6RED750	M 75 OHM, 1/10W	1	
	R3076	ERJ6RED750	M 75 OHM, 1/10W	1	
	R3077	ERJ6RED750	M 75 OHM, 1/10W	1	
	R3078	ERJ6RED750	M 75 OHM, 1/10W	1	
	R3084	ERJ6RED750	M 75 OHM, 1/10W	1	
	R3085	ERJ6RED750	M 75 OHM, 1/10W	1	

Safety	Ref. No.	Part No.	Part Name & Description	Pcs	Remarks
	R3086	ERJ6RED750	M 75 OHM, 1/10W	1	
	R3097	ERJ6RED750	M 75 OHM, 1/10W	1	
	R3101	ERJ2GEJ472	M 4.7KOHM, J, 0.063W	1	
	R3103	ERJ2GEJ472	M 4.7KOHM, J, 0.063W	1	
	R3112	DOYAR0000007	M 0 OHM 1/4W	1	
	R3113	DOYAR0000007	M 0 OHM 1/4W	1	
	R3116	ERJ2GEJ221	M 220 OHM, J, 0.063W	1	
	R3117	ERJ2GEJ221	M 220 OHM, J, 0.063W	1	
	R3118	ERJ2GEJ221	M 220 OHM, J, 0.063W	1	
	R3119	ERJ2GEJ221	M 220 OHM, J, 0.063W	1	
	R3120	ERJ2GEJ331	M 330 OHM, J, 0.063W	1	
	R3121	ERJ6RED750	M 75 OHM, 1/10W	1	
	R3123	ERJ2GEJ221	M 220 OHM, J, 0.063W	1	
	R3124	ERJ2GEJ221	M 220 OHM, J, 0.063W	1	
	R3125	ERJ2GEJ221	M 220 OHM, J, 0.063W	1	
	R3128	ERJ2GEJ221	M 220 OHM, J, 0.063W	1	
	R3129	ERJ2GEJ221	M 220 OHM, J, 0.063W	1	
	R3130	ERJ2GEJ220	M 22 OHM, J, 0.063W	1	
	R3131	ERJ2GEJ220	M 22 OHM, J, 0.063W	1	
	R3132	ERJ2GEJ820	M 82 OHM, J, 0.063W	1	
	R3133	ERJ2GEJ820	M 82 OHM, J, 0.063W	1	
	R3134	ERJ2GEJ820	M 82 OHM, J, 0.063W	1	
	R3136	ERJ2GEJ221	M 220 OHM, J, 0.063W	1	
	R3138	ERJ2GEJ820	M 82 OHM, J, 0.063W	1	
	R3139	ERJ2GEJ820	M 82 OHM, J, 0.063W	1	
	R3140	ERJ2GEJ820	M 82 OHM, J, 0.063W	1	
	R3146	ERJ2GEJ331	M 330 OHM, J, 0.063W	1	
	R3147	ERJ2GEJ472	M 4.7KOHM, J, 0.063W	1	
	R3148	ERJ6RED750	M 75 OHM, 1/10W	1	
	R3149	ERJ6RED750	M 75 OHM, 1/10W	1	
	R3151	ERJ2GEJ220	M 22 OHM, J, 0.063W	1	
	R3152	ERJ2GEJ220	M 22 OHM, J, 0.063W	1	
	R3158	ERJ6GEYOR00V	M 0 OHM J 1/10W	1	
	R3159	ERJ6GEYOR00V	M 0 OHM J 1/10W	1	
	R3167	ERJ6RED750	M 75 OHM, 1/10W	1	
	R3169	ERJ2GEJ104	M 100KOHM, J, 0.063W	1	
	R3186	ERJ6RED750	M 75 OHM, 1/10W	1	
	R3187	ERJ6RED750	M 75 OHM, 1/10W	1	
	R3189	ERJ2GEJ680	M 68 OHM, J, 0.063W	1	
	R3190	ERJ2GEJ680	M 68 OHM, J, 0.063W	1	
	R3191	ERJ2GEJ680	M 68 OHM, J, 0.063W	1	
	R3201	ERJ2GEJ221	M 220 OHM, J, 0.063W	1	
	R3218	DOYAR0000007	M 0 OHM 1/4W	1	
	R3223	ERJ2GEJ680	M 68 OHM, J, 0.063W	1	
	R3225	ERJ2GEJ680	M 68 OHM, J, 0.063W	1	
	R3226	ERJ6GEYJ472V	M 4.7K OHM J 1/10W	1	

Safety	Ref. No.	Part No.	Part Name & Description	Pcs	Remarks
	R3227	ERJ6GEYJ472V	M 4.7K OHM J 1/10W	1	
	R3230	ERJ6RED750	M 75 OHM, 1/10W	1	
	R3232	ERJ6RED750	M 75 OHM, 1/10W	1	
	R3234	ERJ6RED750	M 75 OHM, 1/10W	1	
	R3236	ERJ2GEJ680	M 68 OHM, J,0.063W	1	
	R3237	ERJ2GEJ680	M 68 OHM, J,0.063W	1	
	R3240	ERJ2GEJ221	M 220 OHM, J,0.063W	1	
	R3716	ERJ6GEYJ184	M 180KOHM, J,1/10W	1	
	R3717	ERJ6GEYJ184	M 180KOHM, J,1/10W	1	
	R3721	D0GD103JA036	M 10KOHM, J,0.25W	1	
	R3751	ERJ6ENF1432	M14.3KOHM, 1/10W	1	
	R3753	ERJ6ENF1741	M1.74KOHM, 1/10W	1	
	R3758	ERJ6ENF6651	M6.65KOHM, 1/10W	1	
	R3767	ERJ6ENF7151	M7.15KOHM, 1/10W	1	
	R4280	ERJ2GEJ473	M 47KOHM, J,0.063W	1	
	R4281	ERJ2GEJ473	M 47KOHM, J,0.063W	1	
	R4282	ERJ2GEJ473	M 47KOHM, J,0.063W	1	
	R4284	ERJ2GEJ103	M 10KOHM, J,0.063W	1	
	R4290	ERJ2GEJ103	M 10KOHM, J,0.063W	1	
	R4291	ERJ2GEJ103	M 10KOHM, J,0.063W	1	
	R4292	ERJ2GEJ103	M 10KOHM, J,0.063W	1	
	R4321	ERJ2GEJ103	M 10KOHM, J,0.063W	1	
	R4322	ERJ2GEJ103	M 10KOHM, J,0.063W	1	
	R4323	ERJ2GEJ103	M 10KOHM, J,0.063W	1	
	R4325	ERJ2GEJ103	M 10KOHM, J,0.063W	1	
	R4327	ERJ2GEJ473	M 47KOHM, J,0.063W	1	
	R4330	ERJ2GEJ103	M 10KOHM, J,0.063W	1	
	R4500	ERJ2GEJ103	M 10KOHM, J,0.063W	1	
	R4501	ERJ2GEJ103	M 10KOHM, J,0.063W	1	
	R4502	ERJ2RKD330	M 33 OHM, J, 2W	1	
	R4503	ERJ2RKD330	M 33 OHM, J, 2W	1	
	R4524	D0YAR0000007	M 0 OHM 1/4W	1	
	R4525	D0YAR0000007	M 0 OHM 1/4W	1	
	R4526	ERJ2GEJ102X	M 1K OHM J 1/4W	1	
	R4527	ERJ2GEJ102X	M 1K OHM J 1/4W	1	
	R4528	ERJ2GEJ103	M 10KOHM, J,0.063W	1	
	R4530	ERJ2GEJ103	M 10KOHM, J,0.063W	1	
	R4538	ERJ2GEJ473	M 47KOHM, J,0.063W	1	
	R4540	ERJ2GEJ473	M 47KOHM, J,0.063W	1	
	R4552	ERJ2GEJ220	M 22 OHM, J,0.063W	1	
	R4587	D1BB60400001	M 604 OHM, 1/10W	1	
	R4588	D1BB8060A055	M 806 OHM, 1/10W	1	
	R4589	D1BB8060A055	M 806 OHM, 1/10W	1	
	R4590	ERJ2GEJ103	M 10KOHM, J,0.063W	1	
	R4591	ERJ2GEJ103	M 10KOHM, J,0.063W	1	
	R4592	D1BB8060A055	M 806 OHM, 1/10W	1	
	R4593	D1BB2201A055	M 2.2KOHM, 1/10W	1	
	R4596	ERJ6GEYJ102V	M 1K OHM J 1/10W	1	
	R4597	ERJ6GEYJ102V	M 1K OHM J 1/10W	1	
	R4598	ERJ6GEYJ102V	M 1K OHM J 1/10W	1	

Safety	Ref. No.	Part No.	Part Name & Description	Pcs	Remarks
	R4601	ERJ6GEYJ102V	M 1K OHM J 1/10W	1	
	R4606	D1BB9101A055	M 9.1KOHM, 1/10W	1	
	R4609	D0YAR0000007	M 0 OHM 1/4W	1	
	R4611	D1BB5601A055	M 5.6KOHM, 1/10W	1	
	R4624	ERJ2GEJ103	M 10KOHM, J,0.063W	1	
	R4625	ERJ2GEJ103	M 10KOHM, J,0.063W	1	
	R4626	D1BB2200A055	M 220 OHM, 1/10W	1	
	R4627	D1BB2200A055	M 220 OHM, 1/10W	1	
	R4631	D1BB4990A055	M 499 OHM, 1/10W	1	
	R4634	D1BB2200A055	M 220 OHM, 1/10W	1	
	R4635	EXB28V680JX	RESISTOR ARRAY	1	
	R4636	ERJ2GEJ680	M 68 OHM, J,0.063W	1	
	R4637	ERJ2GEJ680	M 68 OHM, J,0.063W	1	
	R4638	ERJ2GEJ680	M 68 OHM, J,0.063W	1	
	R4639	EXB28V680JX	RESISTOR ARRAY	1	
	R4640	EXB28V680JX	RESISTOR ARRAY	1	
	R4645	ERJ2GEJ680	M 68 OHM, J,0.063W	1	
	R4646	ERJ2GEJ680	M 68 OHM, J,0.063W	1	
	R4647	ERJ2GEJ473	M 47KOHM, J,0.063W	1	
	R4648	EXB28V330J	RESISTOR ARRAY	1	
	R4649	EXB28V680JX	RESISTOR ARRAY	1	
	R4650	ERJ2GEJ680	M 68 OHM, J,0.063W	1	
	R4651	ERJ2GEJ680	M 68 OHM, J,0.063W	1	
	R4652	ERJ2GEJ473	M 47KOHM, J,0.063W	1	
	R4656	ERJ2GEJ222	M 2.2KOHM, J,0.063W	1	
	R4659	D0YAR0000007	M 0 OHM 1/4W	1	
	R4665	ERJ2GEJ473	M 47KOHM, J,0.063W	1	
	R4666	ERJ2GEJ473	M 47KOHM, J,0.063W	1	
	R4670	ERJ2GEJ680	M 68 OHM, J,0.063W	1	
	R4678	EXB28V680JX	RESISTOR ARRAY	1	
	R4679	EXB28V680JX	RESISTOR ARRAY	1	
	R4680	ERJ2GEJ680	M 68 OHM, J,0.063W	1	
	R4699	ERJ2GEJ680	M 68 OHM, J,0.063W	1	
	R4701	ERJ2GEJ473	M 47KOHM, J,0.063W	1	
	R4702	ERJ2GEJ473	M 47KOHM, J,0.063W	1	
	R4703	ERJ2GEJ473	M 47KOHM, J,0.063W	1	
	R4704	ERJ2GEJ473	M 47KOHM, J,0.063W	1	
	R4705	ERJ2GEJ473	M 47KOHM, J,0.063W	1	
	R4821	ERJ2GEJ103	M 10KOHM, J,0.063W	1	
	R4833	ERJ2GEJ473	M 47KOHM, J,0.063W	1	
	R4835	ERJ2GEJ103	M 10KOHM, J,0.063W	1	
	R5400	ERJ2GEJ104	M 100KOHM, J,0.063W	1	
	R5401	ERJ2GEJ103	M 10KOHM, J,0.063W	1	
	R5402	D1BB4532A055	M4.53KOHM, 1/10W	1	
	R5403	D1BB1002A055	M 10KOHM, 1/10W	1	
	R5405	ERJ2GEJ104	M 100KOHM, J,0.063W	1	
	R5406	ERJ2GEJ203X	M 20KOHM, J,0.063W	1	
	R5407	D1BB8872A055	M8.87KOHM, 1/10W	1	
	R5408	D1BB1002A055	M 10KOHM, 1/10W	1	

Safety	Ref. No.	Part No.	Part Name & Description	Pcs	Remarks
	R5510	ERJ2GEJ101	M 100 OHM, J, 0.063W	1	
	R5511	ERJ2GEJ101	M 100 OHM, J, 0.063W	1	
	R5512	ERJ2GEJ101	M 100 OHM, J, 0.063W	1	
	R5535	ERJ2GEJ222	M 2.2KOHM, J, 0.063W	1	
	R5536	ERJ2GEJ472	M 4.7KOHM, J, 0.063W	1	
	R5537	ERJ2GEJ152	M 1.5KOHM, J, 0.063W	1	
	R5538	ERJ2GEJ222	M 2.2KOHM, J, 0.063W	1	
	R5542	ERJ6GEYJ471	M 470 OHM, J, 1/10W	1	
	R5544	ERJ2GEJ221	M 220 OHM, J, 0.063W	1	
	R5546	ERJ2GEJ471	M 470 OHM, J, 0.063W	1	
	R5581	ERJ2GEJ473	M 47KOHM, J, 0.063W	1	
	R5582	ERJ2GEJ473	M 47KOHM, J, 0.063W	1	
	R5583	ERJ2GEJ473	M 47KOHM, J, 0.063W	1	
	R5586	ERJ2GEJ473	M 47KOHM, J, 0.063W	1	
	R5600	ERJ2GEJ680	M 68 OHM, J, 0.063W	1	
	R5604	D1BB4702A055	M 47KOHM, 1/10W	1	
	R5605	D1BB1272A055	M 12.7KOHM, 1/10W	1	
	R5606	DOYAR0000007	M 0 OHM 1/4W	1	
	R5607	DOYAR0000007	M 0 OHM 1/4W	1	
	R5610	ERJ2GEJ104	M 100KOHM, J, 0.063W	1	
	R5611	D1BB4702A055	M 47KOHM, 1/10W	1	
	R5612	D1BB3602A055	M 36KOHM, 1/10W	1	
	R5620	ERJ2GEJ680	M 68 OHM, J, 0.063W	1	
	R5621	D1BB4702A055	M 47KOHM, 1/10W	1	
	R5622	ERJ2GEJ104	M 100KOHM, J, 0.063W	1	
	R5623	D1BB4702A055	M 47KOHM, 1/10W	1	
	R5625	DOYAR0000007	M 0 OHM 1/4W	1	
	R5626	DOYAR0000007	M 0 OHM 1/4W	1	
	R5627	DOYAR0000007	M 0 OHM 1/4W	1	
	R5628	DOYAR0000007	M 0 OHM 1/4W	1	
	R5629	D1BB2802A055	M 28KOHM, 1/10W	1	
	R5630	D1BB4752A055	M 47.5KOHM, 1/10W	1	
	R5631	D1BB3602A055	M 36KOHM, 1/10W	1	
	R5632	D1BB3002A055	M 30KOHM, 1/10W	1	
	R5633	D1BB2802A055	M 28KOHM, 1/10W	1	
	R5634	D1BB2802A055	M 28KOHM, 1/10W	1	
	R5635	ERJ2GEJ223	M 22KOHM, J, 0.063W	1	
	R5636	ERJ2GEJ683	M 68KOHM, J, 0.063W	1	
	R5637	DOYAR0000007	M 0 OHM 1/4W	1	
	R5646	ERJ2GEJ103	M 10KOHM, J, 0.063W	1	
	R5647	ERJ2GEJ473	M 47KOHM, J, 0.063W	1	
	R5657	ERJ2GEJ222	M 2.2KOHM, J, 0.063W	1	
	R5658	ERJ2GEJ473	M 47KOHM, J, 0.063W	1	
	R5659	ERJ2GEJ103	M 10KOHM, J, 0.063W	1	
	R5660	ERJ2GEJ103	M 10KOHM, J, 0.063W	1	
	R5661	ERJ2GEJ123	M 12KOHM, J, 0.063W	1	
	R5662	ERJ2GEJ473	M 47KOHM, J, 0.063W	1	
	R5664	DOYAR0000007	M 0 OHM 1/4W	1	
	R5702	ERJ2GEJ222	M 2.2KOHM, J, 0.063W	1	

Safety	Ref. No.	Part No.	Part Name & Description	Pcs	Remarks
	R5763	ERJ2GEJ101	M 100 OHM, J, 0.063W	1	
	R7701	ERJ2GEJ680	M 68 OHM, J, 0.063W	1	
	R7702	DOYAR0000007	M 0 OHM 1/4W	1	
	R7703	ERJ2GEJ680	M 68 OHM, J, 0.063W	1	
	R7704	ERJ2GEJ680	M 68 OHM, J, 0.063W	1	
	R7705	ERJ2GEJ680	M 68 OHM, J, 0.063W	1	
	R7706	DOGBR00Z0002	M 0 OHM J 1/16W	1	
	R7708	DOGBR00Z0002	M 0 OHM J 1/16W	1	
	R7709	ERJ2GEJ680	M 68 OHM, J, 0.063W	1	
	R7710	ERJ2GEJ101	M 100 OHM, J, 0.063W	1	
	R7713	DOYAR0000007	M 0 OHM 1/4W	1	
	R7716	DOGBR00Z0002	M 0 OHM J 1/16W	1	
	R7731	DOYAR0000007	M 0 OHM 1/4W	1	
	R7795	DOGBR00Z0002	M 0 OHM J 1/16W	1	
	R7796	DOGBR00Z0002	M 0 OHM J 1/16W	1	
	R7797	DOGBR00Z0002	M 0 OHM J 1/16W	1	
	R7798	DOGBR00Z0002	M 0 OHM J 1/16W	1	
	R8001	ERJ2GEJ221	M 220 OHM, J, 0.063W	1	
	R8002	ERJ2GEJ560X	M 56 OHM, J, 0.063W	1	
	R8004	D1BB2402A055	M 24KOHM, 1/10W	1	
	R8005	D1BB1002A055	M 10KOHM, 1/10W	1	
	R8006	D1BB6801A055	M 6.8KOHM, 1/10W	1	
	R8023	DOYAR0000007	M 0 OHM 1/4W	1	
	R8024	DOYAR0000007	M 0 OHM 1/4W	1	
	R8025	DOYAR0000007	M 0 OHM 1/4W	1	
	R8026	DOYAR0000007	M 0 OHM 1/4W	1	
	R8027	DOYAR0000007	M 0 OHM 1/4W	1	
	R8028	DOYAR0000007	M 0 OHM 1/4W	1	
	R8029	DOYAR0000007	M 0 OHM 1/4W	1	
	R8030	ERJ2GEJ101	M 100 OHM, J, 0.063W	1	
	R8031	D1BB2700A055	M 270 OHM, 1/10W	1	
	R8032	D1BB2700A055	M 270 OHM, 1/10W	1	
	R8035	DOYAR0000007	M 0 OHM 1/4W	1	
	R8036	DOGBR00Z0002	M 0 OHM J 1/16W	1	
	R8039	DOYAR0000007	M 0 OHM 1/4W	1	
	R8056	ERJ2GEJ470	M 47 OHM, J, 0.063W	1	
	R8057	ERJ2GEJ470	M 47 OHM, J, 0.063W	1	
	R8058	ERJ2GEJ470	M 47 OHM, J, 0.063W	1	
	R8059	ERJ2GEJ470	M 47 OHM, J, 0.063W	1	
	R8060	ERJ2GEJ470	M 47 OHM, J, 0.063W	1	
	R8061	ERJ2GEJ470	M 47 OHM, J, 0.063W	1	
	R8062	ERJ2GEJ470	M 47 OHM, J, 0.063W	1	
	R8063	ERJ2GEJ470	M 47 OHM, J, 0.063W	1	
	R8064	ERJ2GEJ470	M 47 OHM, J, 0.063W	1	
	R8065	ERJ2GEJ470	M 47 OHM, J, 0.063W	1	
	R8066	ERJ2GEJ470	M 47 OHM, J, 0.063W	1	
	R8067	ERJ2GEJ470	M 47 OHM, J, 0.063W	1	
	R8068	ERJ2GEJ470	M 47 OHM, J, 0.063W	1	
	R8069	ERJ2GEJ470	M 47 OHM, J, 0.063W	1	
	R8070	ERJ2GEJ470	M 47 OHM, J, 0.063W	1	
	R8071	ERJ2GEJ470	M 47 OHM, J, 0.063W	1	

Safety	Ref. No.	Part No.	Part Name & Description	Pcs	Remarks
	R8072	ERJ2GEJ470	M 47 OHM, J,0.063W	1	
	R8073	ERJ2GEJ470	M 47 OHM, J,0.063W	1	
	R8074	ERJ2GEJ221	M 220 OHM, J,0.063W	1	
	R8075	ERJ2GEJ470	M 47 OHM, J,0.063W	1	
	R8076	ERJ2GEJ470	M 47 OHM, J,0.063W	1	
	R8077	ERJ2GEJ470	M 47 OHM, J,0.063W	1	
	R8078	ERJ2GEJ470	M 47 OHM, J,0.063W	1	
	R8079	D0YAR0000007	M 0 OHM 1/4W	1	
	R8080	D0YAR0000007	M 0 OHM 1/4W	1	
	R8081	ERJ2GEJ103	M 10KOHM, J,0.063W	1	
	R8082	D1BA75R0A014	M0.75KOHM, 1/10W	1	
	R8083	ERJ2GEJ301	M 300 OHM, J,0.063W	1	
	R8084	D0YAR0000007	M 0 OHM 1/4W	1	
	R8086	ERJ2GEJ104	M 100KOHM, J,0.063W	1	
	R8087	ERJ2GEJ103	M 10KOHM, J,0.063W	1	
	R8090	ERJ2GEJ103	M 10KOHM, J,0.063W	1	
	R8091	ERJ2GEJ101	M 100 OHM, J,0.063W	1	
	R8093	ERJ2GEJ470	M 47 OHM, J,0.063W	1	
	R8095	ERJ2GEJ103	M 10KOHM, J,0.063W	1	
	R8097	ERJ2GEJ221	M 220 OHM, J,0.063W	1	
	R8098	ERJ2GEJ103	M 10KOHM, J,0.063W	1	
	R8099	ERJ2GEJ103	M 10KOHM, J,0.063W	1	
	R8100	ERJ2GEJ470	M 47 OHM, J,0.063W	1	
	R8101	ERJ2GEJ103	M 10KOHM, J,0.063W	1	
	R8106	ERJ2GEJ202	M 2KOHM, J,0.063W	1	
	R8107	ERJ2GEJ101	M 100 OHM, J,0.063W	1	
	R8108	ERJ2GEJ223	M 22KOHM, J,0.063W	1	
	R8328	ERJ2GEJ103	M 10KOHM, J,0.063W	1	
	R8386	D0YAR0000007	M 0 OHM 1/4W	1	
	R8471	ERJ2GEJ103	M 10KOHM, J,0.063W	1	
	R8472	EXB2HV103JV	RESISTOR ARRAY	1	
	R8474	EXB28V103JX	RESISTOR ARRAY	1	
	R8475	EXB28V103JX	RESISTOR ARRAY	1	
	R8501	ERJ2GEJ101	M 100 OHM, J,0.063W	1	
	R8502	ERJ2GEJ331	M 330 OHM, J,0.063W	1	
	R8503	ERJ2GEJ331	M 330 OHM, J,0.063W	1	
	R8504	ERJ2GEJ331	M 330 OHM, J,0.063W	1	
	R8506	ERJ2GEJ331	M 330 OHM, J,0.063W	1	
	R8508	D1BB91R0A055	M 91 OHM, 1/10W	1	
	R8509	D1BB91R0A055	M 91 OHM, 1/10W	1	
	R8510	D1BB91R0A055	M 91 OHM, 1/10W	1	
	R8556	ERJ2GEJ103	M 10KOHM, J,0.063W	1	
	R8564	ERJ2GEJ103	M 10KOHM, J,0.063W	1	
	R8566	D0YAR0000007	M 0 OHM 1/4W	1	
	R8603	ERJ2GEJ473	M 47KOHM, J,0.063W	1	

Safety	Ref. No.	Part No.	Part Name & Description	Pcs	Remarks
	R8605	ERJ2GEJ680	M 68 OHM, J,0.063W	1	
	R8657	ERJ2GEJ103	M 10KOHM, J,0.063W	1	
	R8658	ERJ2GEJ220	M 22 OHM, J,0.063W	1	
	R8710	ERJ2GEJ680	M 68 OHM, J,0.063W	1	
	R8711	ERJ2GEJ103	M 10KOHM, J,0.063W	1	
	R8712	ERJ2GEJ103	M 10KOHM, J,0.063W	1	
	R8751	ERJ2GEJ103	M 10KOHM, J,0.063W	1	
	R8802	ERJ2GEJ103	M 10KOHM, J,0.063W	1	
	R8803	ERJ2GEJ103	M 10KOHM, J,0.063W	1	
	R8804	ERJ2GEJ103	M 10KOHM, J,0.063W	1	
	R8805	ERJ2GEJ103	M 10KOHM, J,0.063W	1	
	R8806	ERJ2GEJ103	M 10KOHM, J,0.063W	1	
	R8807	ERJ2GEJ103	M 10KOHM, J,0.063W	1	
	R8808	ERJ2GEJ103	M 10KOHM, J,0.063W	1	
	R8809	ERJ2GEJ103	M 10KOHM, J,0.063W	1	
	R8810	EXB28VR000X	RESISTOR ARRAY	1	
	R8811	D0YAR0000007	M 0 OHM 1/4W	1	
	R8812	D0YAR0000007	M 0 OHM 1/4W	1	
	R8813	EXB28V680JX	RESISTOR ARRAY	1	
	R8814	ERJ2GEJ680	M 68 OHM, J,0.063W	1	
	R8815	ERJ2GEJ680	M 68 OHM, J,0.063W	1	
	R8816	ERJ2GEJ680	M 68 OHM, J,0.063W	1	
	R8817	ERJ2GEJ680	M 68 OHM, J,0.063W	1	
	R8833	D0GBR00Z0002	M 0 OHM J 1/16W	1	
	R8851	D0YAR0000007	M 0 OHM 1/4W	1	
	R8852	D0YAR0000007	M 0 OHM 1/4W	1	
	R8853	D0YAR0000007	M 0 OHM 1/4W	1	
	R8861	ERJ2GEJ103	M 10KOHM, J,0.063W	1	
	R8865	EXB2HV680J	RESISTOR ARRAY	1	
	R8866	EXB2HV680J	RESISTOR ARRAY	1	
	R8867	EXB2HV680J	RESISTOR ARRAY	1	
	R8868	ERJ2GEJ680	M 68 OHM, J,0.063W	1	
	R8871	ERJ2GEJ103	M 10KOHM, J,0.063W	1	
	R8873	ERJ2GEJ103	M 10KOHM, J,0.063W	1	
	R8875	ERJ2GEJ103	M 10KOHM, J,0.063W	1	
	R8876	ERJ2GEJ103	M 10KOHM, J,0.063W	1	
	R8877	ERJ2GEJ680	M 68 OHM, J,0.063W	1	
	R8878	ERJ2GEJ680	M 68 OHM, J,0.063W	1	
	R8879	ERJ2GEJ680	M 68 OHM, J,0.063W	1	
	R8880	ERJ2GEJ680	M 68 OHM, J,0.063W	1	
	R8882	ERJ2GEJ680	M 68 OHM, J,0.063W	1	
	R8883	ERJ2GEJ680	M 68 OHM, J,0.063W	1	
	R8884	ERJ2GEJ680	M 68 OHM, J,0.063W	1	
	R8885	ERJ2GEJ680	M 68 OHM, J,0.063W	1	
	R8886	ERJ2GEJ680	M 68 OHM, J,0.063W	1	

Safety	Ref. No.	Part No.	Part Name & Description	Pcs	Remarks
	R8887	ERJ2GEJ680	M 68 OHM, J, 0.063W	1	
	R8888	ERJ2GEJ680	M 68 OHM, J, 0.063W	1	
	R8889	ERJ2GEJ680	M 68 OHM, J, 0.063W	1	
	R8891	ERJ2GEJ680	M 68 OHM, J, 0.063W	1	
	R8892	ERJ2GEJ680	M 68 OHM, J, 0.063W	1	
	R8894	ERJ2GEJ680	M 68 OHM, J, 0.063W	1	
	R8896	DOYAR0000007	M 0 OHM 1/4W	1	
	R8897	DOYAR0000007	M 0 OHM 1/4W	1	
	R8898	ERJ2GEJ103	M 10KOHM, J, 0.063W	1	
	R8900	ERJ2GEJ680	M 68 OHM, J, 0.063W	1	
	R8901	ERJ2GEJ680	M 68 OHM, J, 0.063W	1	
	R8904	ERJ2GEJ103	M 10KOHM, J, 0.063W	1	
	R8905	ERJ2GEJ103	M 10KOHM, J, 0.063W	1	
	R8906	ERJ2GEJ103	M 10KOHM, J, 0.063W	1	
	R8907	ERJ2GEJ103	M 10KOHM, J, 0.063W	1	
	R8908	ERJ2GEJ103	M 10KOHM, J, 0.063W	1	
	R8909	ERJ2GEJ103	M 10KOHM, J, 0.063W	1	
	R8910	ERJ2GEJ103	M 10KOHM, J, 0.063W	1	
	R8911	ERJ2GEJ680	M 68 OHM, J, 0.063W	1	
	R8912	ERJ2GEJ680	M 68 OHM, J, 0.063W	1	
	R8913	ERJ2GEJ680	M 68 OHM, J, 0.063W	1	
	R8914	ERJ2GEJ680	M 68 OHM, J, 0.063W	1	
	R8915	ERJ2GEJ680	M 68 OHM, J, 0.063W	1	
	R8916	ERJ2GEJ680	M 68 OHM, J, 0.063W	1	
	R8917	ERJ2GEJ680	M 68 OHM, J, 0.063W	1	
	R8918	ERJ2GEJ680	M 68 OHM, J, 0.063W	1	
	R8919	ERJ2GEJ472	M 4.7KOHM, J, 0.063W	1	
	R8920	ERJ2GEJ472	M 4.7KOHM, J, 0.063W	1	
	R8921	ERJ2GEJ472	M 4.7KOHM, J, 0.063W	1	
	R8922	ERJ2GEJ472	M 4.7KOHM, J, 0.063W	1	
	R8923	ERJ2GEJ332	M 3.3KOHM, J, 0.063W	1	
	R8924	ERJ2GEJ332	M 3.3KOHM, J, 0.063W	1	
	R8925	ERJ2GEJ472	M 4.7KOHM, J, 0.063W	1	
	R8926	ERJ2GEJ472	M 4.7KOHM, J, 0.063W	1	
	R8927	DOYAR0000007	M 0 OHM 1/4W	1	
	R8929	EXB2HVR000	RESISTOR ARRAY	1	
	R8935	ERJ2GEJ103	M 10KOHM, J, 0.063W	1	
	R8952	EXB2HV680J	RESISTOR ARRAY	1	
	R8953	EXB2HV680J	RESISTOR ARRAY	1	
	R8957	ERJ2GEJ103	M 10KOHM, J, 0.063W	1	
	R8958	ERJ2GEJ103	M 10KOHM, J, 0.063W	1	
	R8959	ERJ2GEJ680	M 68 OHM, J, 0.063W	1	
	R8960	ERJ2GEJ680	M 68 OHM, J, 0.063W	1	

Safety	Ref. No.	Part No.	Part Name & Description	Pcs	Remarks
	R8963	ERJ2GEJ103	M 10KOHM, J, 0.063W	1	
	R9062	ERJ2GEJ101	M 100 OHM, J, 0.063W	1	
	R9063	ERJ2GEJ101	M 100 OHM, J, 0.063W	1	
	R9064	ERJ2GEJ101	M 100 OHM, J, 0.063W	1	
	R9065	ERJ2GEJ101	M 100 OHM, J, 0.063W	1	
	R9066	ERJ2GEJ101	M 100 OHM, J, 0.063W	1	
	R9067	ERJ2GEJ101	M 100 OHM, J, 0.063W	1	
	R9068	ERJ2GEJ103	M 10KOHM, J, 0.063W	1	
	R9070	ERJ2GEJ103	M 10KOHM, J, 0.063W	1	
	R9071	ERJ2GEJ223	M 22KOHM, J, 0.063W	1	
	R9072	ERJ2GEJ102X	M 1K OHM J 1/4W	1	
	R9080	ERJ2GEJ103	M 10KOHM, J, 0.063W	1	
	R9085	ERJ2GEJ472	M 4.7KOHM, J, 0.063W	1	
	R9086	ERJ2GEJ472	M 4.7KOHM, J, 0.063W	1	
	R9088	ERJ2GEJ104	M 100KOHM, J, 0.063W	1	
	R9089	ERJ2GEJ103	M 10KOHM, J, 0.063W	1	
	R9090	ERJ2GEJ103	M 10KOHM, J, 0.063W	1	
	R9091	ERJ2GEJ472	M 4.7KOHM, J, 0.063W	1	
	R9105	ERJ2GEJ103	M 10KOHM, J, 0.063W	1	
	R9107	ERJ2GEJ332	M 3.3KOHM, J, 0.063W	1	
	R9110	ERJ2GEJ101	M 100 OHM, J, 0.063W	1	
	R9116	ERJ2GEJ101	M 100 OHM, J, 0.063W	1	
	R9119	EXB38V470J	RESISTOR ARRAY	1	
	R9121	ERJ2GEJ104	M 100KOHM, J, 0.063W	1	
	R9122	EXB38V103JV	RESISTOR ARRAY	1	
	R9123	ERJ2GEJ102X	M 1K OHM J 1/4W	1	
	R9124	ERJ2GEJ470	M 47 OHM, J, 0.063W	1	
	R9125	ERJ2GEJ102X	M 1K OHM J 1/4W	1	
	R9126	ERJ2GEJ102X	M 1K OHM J 1/4W	1	
	R9127	ERJ2GEJ683	M 68KOHM, J, 0.063W	1	
	R9128	DOGDR00Z0002	M 0 OHM, 1/10W	1	
	R9129	ERJ2GEJ473	M 47KOHM, J, 0.063W	1	
	R9130	ERJ2GEJ470	M 47 OHM, J, 0.063W	1	
	R9131	ERJ2GEJ104	M 100KOHM, J, 0.063W	1	
	R9132	ERJ2GEJ472	M 4.7KOHM, J, 0.063W	1	
	R9133	ERJ2GEJ102X	M 1K OHM J 1/4W	1	
	R9134	ERJ2GEJ333	M 33KOHM, J, 0.063W	1	
	R9141	ERJ2GEJ101	M 100 OHM, J, 0.063W	1	
	R9142	ERJ2GEJ101	M 100 OHM, J, 0.063W	1	
	R9149	ERJ2GEJ472	M 4.7KOHM, J, 0.063W	1	
	R9158	ERJ2GEJ103	M 10KOHM, J, 0.063W	1	
	R9159	ERJ2GEJ103	M 10KOHM, J, 0.063W	1	
	R9161	ERJ2GEJ101	M 100 OHM, J, 0.063W	1	
	R9162	ERJ2GEJ103	M 10KOHM, J, 0.063W	1	

Safety	Ref. No.	Part No.	Part Name & Description	Pcs	Remarks
	R9163	ERJ2GEJ103	M 10KOHM, J, 0.063W	1	
	R9164	ERJ2GEJ103	M 10KOHM, J, 0.063W	1	
	R9166	ERJ2GEJ103	M 10KOHM, J, 0.063W	1	
	R9170	ERJ2GEJ393	M 39KOHM, J, 0.063W	1	
	R9171	ERJ2GEJ393	M 39KOHM, J, 0.063W	1	
	R9172	ERJ2GEJ393	M 39KOHM, J, 0.063W	1	
	R9187	ERJ2GEJ472	M 4.7KOHM, J, 0.063W	1	
	R9188	ERJ2GEJ472	M 4.7KOHM, J, 0.063W	1	
	R9189	ERJ2GEJ103	M 10KOHM, J, 0.063W	1	
	R9203	ERJ2GEJ223	M 22KOHM, J, 0.063W	1	
	R9205	ERJ2GEJ333	M 33KOHM, J, 0.063W	1	
	R9206	ERJ2GED563X	M 56KOHM, J, 0.063W	1	
	R9207	ERJ2GEJ243	M 24KOHM, J, 0.063W	1	
	R9215	ERJ2GEJ104	M 100KOHM, J, 0.063W	1	
	R9223	ERJ2GEJ222	M 2.2KOHM, J, 0.063W	1	
	R9225	ERJ2GEJ222	M 2.2KOHM, J, 0.063W	1	
	R9317	ERJ2GEJ102X	M 1K OHM J 1/4W	1	
	R9347	EXB2HV220JV	RESISTOR ARRAY	1	
	R9348	EXB2HV220JV	RESISTOR ARRAY	1	
	R9350	ERJ2GEJ470	M 47 OHM, J, 0.063W	1	
	R9351	ERJ2GEJ470	M 47 OHM, J, 0.063W	1	
	R9352	EXB2HV470JV	RESISTOR ARRAY	1	
	R9353	EXB2HV220JV	RESISTOR ARRAY	1	
	R9354	EXB2HV220JV	RESISTOR ARRAY	1	
	R9355	EXB2HV470JV	RESISTOR ARRAY	1	
	R9356	EXB2HV220JV	RESISTOR ARRAY	1	
	R9357	EXB2HV220JV	RESISTOR ARRAY	1	
	R9358	EXB2HV470JV	RESISTOR ARRAY	1	
	R9359	EXB2HV470JV	RESISTOR ARRAY	1	
	R9361	ERJ2GEJ470	M 47 OHM, J, 0.063W	1	
	R9362	ERJ2GEJ470	M 47 OHM, J, 0.063W	1	
	R9369	ERJ2GEJ472	M 4.7KOHM, J, 0.063W	1	
	R9370	ERJ2GEJ103	M 10KOHM, J, 0.063W	1	
	R9371	ERJ2GEJ104	M 100KOHM, J, 0.063W	1	
	R9385	ERJ2GEJ472	M 4.7KOHM, J, 0.063W	1	
	R9391	ERJ2GEJ104	M 100KOHM, J, 0.063W	1	
	R9396	ERJ2GEJ470	M 47 OHM, J, 0.063W	1	
	R9397	ERJ2GEJ470	M 47 OHM, J, 0.063W	1	
	R9398	ERJ2GEJ470	M 47 OHM, J, 0.063W	1	
	R9399	ERJ2GEJ470	M 47 OHM, J, 0.063W	1	
	R9401	ERJ2GEJ102X	M 1K OHM J 1/4W	1	
	R9402	ERJ2GEJ470	M 47 OHM, J, 0.063W	1	
	R9403	EXB2HV103JV	RESISTOR ARRAY	1	
	R9404	EXB2HV103JV	RESISTOR ARRAY	1	
	R9405	EXB2HV103JV	RESISTOR ARRAY	1	
	R9406	EXB2HV103JV	RESISTOR ARRAY	1	
	R9578	ERJ2GEJ472	M 4.7KOHM, J, 0.063W	1	

Safety	Ref. No.	Part No.	Part Name & Description	Pcs	Remarks
	R9586	ERJ2GEJ470	M 47 OHM, J, 0.063W	1	
	R9587	ERJ2GEJ470	M 47 OHM, J, 0.063W	1	
	R9588	ERJ2GEJ472	M 4.7KOHM, J, 0.063W	1	
	R9598	ERJ2GEJ470	M 47 OHM, J, 0.063W	1	
	R9604	ERJ2GEJ103	M 10KOHM, J, 0.063W	1	
	R9608	EXB2HV470JV	RESISTOR ARRAY	1	
	R9609	EXB2HV470JV	RESISTOR ARRAY	1	
	R9610	EXB2HV470JV	RESISTOR ARRAY	1	
	R9611	ERJ2GEJ680	M 68 OHM, J, 0.063W	1	
	R9616	ERJ2GEJ470	M 47 OHM, J, 0.063W	1	
	R9618	ERJ2GEJ331	M 330 OHM, J, 0.063W	1	
	R9828	ERJ2GEJ473	M 47KOHM, J, 0.063W	1	
	R9839	EXB38V101JV	RESISTOR ARRAY	1	
	R9846	EXB2HV103JV	RESISTOR ARRAY	1	
	R9847	EXB2HV103JV	RESISTOR ARRAY	1	
	R9848	EXB2HV470JV	RESISTOR ARRAY	1	
	R9849	EXB2HV470JV	RESISTOR ARRAY	1	
	R9854	D0YAR0000007	M 0 OHM 1/4W	1	
	R9868	ERJ2GEJ104	M 100KOHM, J, 0.063W	1	
	R9869	ERJ2GEJ103	M 10KOHM, J, 0.063W	1	
	R9870	ERJ2GEJ103	M 10KOHM, J, 0.063W	1	
	R9871	ERJ2GEJ103	M 10KOHM, J, 0.063W	1	
	R9878	D1BB1502A055	M 15KOHM, 1/10W	1	
	R9879	D1BB1302A055	M 13KOHM, 1/10W	1	
	R9886	D1BB4702A055	M 47KOHM, 1/10W	1	
	R9887	D1BB5102A055	M 51KOHM, 1/10W	1	
	R9888	D1BB1502A055	M 15KOHM, 1/10W	1	
	R9889	D1BB1822A055	M18.2KOHM, 1/10W	1	
	R9890	D1BB4752A055	M47.5KOHM, 1/10W	1	
	R9891	D1BB1272A055	M12.7KOHM, 1/10W	1	
	R9892	ERJ2GEJ104	M 100KOHM, J, 0.063W	1	
	R9893	D1BB4302A055	M 43KOHM, 1/10W	1	
	R9894	D1BB2002A055	M 20KOHM, 1/10W	1	
	R9895	ERJ2GEJ104	M 100KOHM, J, 0.063W	1	
	R9896	D1BB1822A055	M18.2KOHM, 1/10W	1	
	R9897	D1BB4752A055	M47.5KOHM, 1/10W	1	
	R9903	EXB2HV470JV	RESISTOR ARRAY	1	
	R9905	ERJ2RKD330	M 33 OHM, J, 2W	1	
	R9906	EXB38V470J	RESISTOR ARRAY	1	
	R9907	ERJ2GEJ151	M 150 OHM, J, 0.063W	1	
	R9936	D1BB1001A055	M 1KOHM, 1/16W	1	
	R9937	D1BB1001A055	M 1KOHM, 1/16W	1	
	R9938	D1BB1001A055	M 1KOHM, 1/16W	1	
	R9939	D1BB1001A055	M 1KOHM, 1/16W	1	
	R9940	ERJ2RKD330	M 33 OHM, J, 2W	1	
	R9943	EXB2HV470JV	RESISTOR ARRAY	1	
	R9944	EXB38V470J	RESISTOR ARRAY	1	
	R9945	EXB38V470J	RESISTOR ARRAY	1	
	R9946	EXB38V470J	RESISTOR ARRAY	1	
	R9947	EXB38V470J	RESISTOR ARRAY	1	
	R9948	EXB38V470J	RESISTOR ARRAY	1	
	R9949	EXB38V470J	RESISTOR ARRAY	1	
	R9950	EXB38V470J	RESISTOR ARRAY	1	
	R9951	EXB38V470J	RESISTOR ARRAY	1	
	R9952	ERJ2GEJ470	M 47 OHM, J, 0.063W	1	
	R9953	ERJ2GEJ470	M 47 OHM, J, 0.063W	1	
	R9954	ERJ2GEJ470	M 47 OHM, J, 0.063W	1	

Safety	Ref. No.	Part No.	Part Name & Description	Pcs	Remarks
	R9955	ERJ2GEJ470	M 47 OHM, J, 0.063W	1	
	R9956	DOGDR00Z0002	M 0 OHM, 1/10W	1	
	R9957	DOGDR00Z0002	M 0 OHM, 1/10W	1	
	R9958	DOGDR00Z0002	M 0 OHM, 1/10W	1	
	R9966	ERJ2GEJ681	M 680 OHM, J, 0.063W	1	
	R9967	ERJ2GEJ470	M 47 OHM, J, 0.063W	1	
	R9968	ERJ2GEJ470	M 47 OHM, J, 0.063W	1	
	R9969	ERJ2GEJ470	M 47 OHM, J, 0.063W	1	
	R9970	ERJ2GEJ470	M 47 OHM, J, 0.063W	1	
	R9972	ERJ2GEJ103	M 10KOHM, J, 0.063W	1	
	R9975	ERJ2GEJ470	M 47 OHM, J, 0.063W	1	
	R9977	ERJ2GEJ470	M 47 OHM, J, 0.063W	1	
	R9983	ERJ2GEJ470	M 47 OHM, J, 0.063W	1	
	R9986	ERJ2GEJ102X	M 1K OHM J 1/4W	1	
	R9988	ERJ2GEJ470	M 47 OHM, J, 0.063W	1	
	R9989	ERJ2GEJ332	M 3.3KOHM, J, 0.063W	1	
	R9990	ERJ2GEJ103	M 10KOHM, J, 0.063W	1	
	R14349	DOGD103JA036	M 10KOHM, J, 0.25W	1	
	R14901	DOGD101JA036	M 100 OHM, J, 0.25W	1	
	R14902	ERJ6GEYJ221V	M 220 OHM, J, 1/10W	1	
	R14903	ERJ6GEYJ221V	M 220 OHM, J, 1/10W	1	
	R14904	ERJ6GEYJ221V	M 220 OHM, J, 1/10W	1	
	R14905	ERJ6GEYJ221V	M 220 OHM, J, 1/10W	1	
	R14906	ERJ6GEYJ221V	M 220 OHM, J, 1/10W	1	
	R14907	ERJ3GEYJ220	M 22 OHM, J, 1/16W	1	
	R14908	ERJ3GEYJ220	M 22 OHM, J, 1/16W	1	
	R14909	ERJ3GEYJ220	M 22 OHM, J, 1/16W	1	
	R14910	ERJ3GEYJ220	M 22 OHM, J, 1/16W	1	
	R14911	DOGD103JA036	M 10KOHM, J, 0.25W	1	
	R14912	DOGD103JA036	M 10KOHM, J, 0.25W	1	
	R14913	DOGD103JA036	M 10KOHM, J, 0.25W	1	
	R14914	DOGD103JA036	M 10KOHM, J, 0.25W	1	
	R14915	ERJ3GEYJ220	M 22 OHM, J, 1/16W	1	
	R14916	DOGD103JA036	M 10KOHM, J, 0.25W	1	
	R14917	ERJ3GEYJ220	M 22 OHM, J, 1/16W	1	
	R14919	ERJ3GEYJ220	M 22 OHM, J, 1/16W	1	
	R14920	ERJ3GEYJ220	M 22 OHM, J, 1/16W	1	
	R14921	ERJ8GEYJ224V	M 220KOHM, J, 1/8W	1	
	R14923	DOGD103JA036	M 10KOHM, J, 0.25W	1	
	R14924	DOGD103JA036	M 10KOHM, J, 0.25W	1	
	R14925	DOGD103JA036	M 10KOHM, J, 0.25W	1	
	R14926	DOGD103JA036	M 10KOHM, J, 0.25W	1	
	R14927	ERJ3GEYJ220	M 22 OHM, J, 1/16W	1	
	R14943	ERJ6GEYJ470V	M 47 OHM, J, 1/10W	1	
	R14944	ERJ6GEYJ100V	M 10 OHM, J, 1/10W	1	
	R14945	DOGDR00Z0002	M 0 OHM, 1/10W	1	
	R14946	DOGDR00Z0002	M 0 OHM, 1/10W	1	
	R14947	DOGDR00Z0002	M 0 OHM, 1/10W	1	
	R14948	DOGDR00Z0002	M 0 OHM, 1/10W	1	
	R14949	ERJ6GEYJ203	M 20KOHM, J, 1/10W	1	
	R14950	DOGD103JA036	M 10KOHM, J, 0.25W	1	
	R14951	ERJ6GEYJ221V	M 220 OHM, J, 1/10W	1	
	R14952	ERJ6GEYJ221V	M 220 OHM, J, 1/10W	1	
	R14953	ERJ6GEYJ221V	M 220 OHM, J, 1/10W	1	

Safety	Ref. No.	Part No.	Part Name & Description	Pcs	Remarks
	R14954	ERJ6GEYJ221V	M 220 OHM, J, 1/10W	1	
	R14955	ERJ6GEYJ221V	M 220 OHM, J, 1/10W	1	
	R14956	ERJ3GEYJ220	M 22 OHM, J, 1/16W	1	
	R14957	ERJ3GEYJ220	M 22 OHM, J, 1/16W	1	
	R14958	ERJ3GEYJ220	M 22 OHM, J, 1/16W	1	
	R14959	ERJ3GEYJ220	M 22 OHM, J, 1/16W	1	
	R14960	ERJ3GEYJ220	M 22 OHM, J, 1/16W	1	
	R14961	ERJ6GEYJ331V	M 330 OHM J 1/10W	1	
	R14962	ERJ6GEYJ331V	M 330 OHM J 1/10W	1	
	R14963	ERJ6GEYJ331V	M 330 OHM J 1/10W	1	
	R14964	ERJ3GEYJ220	M 22 OHM, J, 1/16W	1	
	R14965	ERJ6GEYJ331V	M 330 OHM J 1/10W	1	
	R14966	ERJ3GEYJ220	M 22 OHM, J, 1/16W	1	
	R14967	ERJ3GEYJ220	M 22 OHM, J, 1/16W	1	
	R14968	DOGD103JA036	M 10KOHM, J, 0.25W	1	
	R14969	ERJ6GEYJ332V	M 3.3K OHM J 1/10W	1	
	R14970	ERJ6GEYJ472V	M 4.7K OHM J 1/10W	1	
	R14971	ERJT06J103V	M 10KOHM, F, 0.25W	1	
	R14972	ERJT06J103V	M 10KOHM, F, 0.25W	1	
	R14973	ERJ3GEYJ470	M 47 OHM, J, 1/16W	1	
	R14974	ERJ3GEYJ470	M 47 OHM, J, 1/16W	1	
	R14975	ERJ3GEYJ470	M 47 OHM, J, 1/16W	1	
	R14976	ERJ3GEYJ470	M 47 OHM, J, 1/16W	1	
	R14977	ERJ6GEYJ222V	M 2.2K OHM J 1/10W	1	
	R14978	ERJ6GEYJ222V	M 2.2K OHM J 1/10W	1	
	R14979	ERJ6GEYJ222V	M 2.2K OHM J 1/10W	1	
	R14980	ERJ6GEYJ221V	M 220 OHM, J, 1/10W	1	
	R14981	DOGD103JA036	M 10KOHM, J, 0.25W	1	
	R14982	DOGD103JA036	M 10KOHM, J, 0.25W	1	
	R14984	DOGD103JA036	M 10KOHM, J, 0.25W	1	
	R14986	ERJ8GEYJ224V	M 220KOHM, J, 1/8W	1	
	R14987	ERJ3GEYJ470	M 47 OHM, J, 1/16W	1	
	R14988	ERJ6GEYJ222V	M 2.2K OHM J 1/10W	1	
	R14989	ERJ6ENF1502	M 15KOHM, 1/10W	1	
	R14990	DOGD103JA036	M 10KOHM, J, 0.25W	1	
	R14991	ERJ3GEYJ220	M 22 OHM, J, 1/16W	1	
	R14992	ERJ3GEYJ470	M 47 OHM, J, 1/16W	1	
	R14993	ERJ3GEYJ470	M 47 OHM, J, 1/16W	1	
	R14994	ERJ3GEYJ470	M 47 OHM, J, 1/16W	1	
	R14995	DOGD103JA036	M 10KOHM, J, 0.25W	1	
	R14996	DOGD103JA036	M 10KOHM, J, 0.25W	1	
	R14997	DOGD103JA036	M 10KOHM, J, 0.25W	1	
	R14998	DOGD103JA036	M 10KOHM, J, 0.25W	1	
	R16001	ERJT08J7R5V	M 7.5OHM, J, 0.33W	1	
	R16002	ERJT08J7R5V	M 7.5OHM, J, 0.33W	1	
	R16021	ERJT08J7R5V	M 7.5OHM, J, 0.33W	1	
	R16022	ERJT08J7R5V	M 7.5OHM, J, 0.33W	1	
	R16031	ERJ6ENF8202	M 82KOHM, 1/10W	1	
	R16032	ERJ6ENF8202	M 82KOHM, 1/10W	1	
	R16033	ERJ6ENF5602	M 56KOHM, 1/10W	1	
	R16034	ERJ6ENF2702	M 27KOHM, 1/10W	1	
	R16041	ERJT08J5R6V	M 5.6 OHM, F, 0.33W	1	
	R16051	ERJT08J5R6V	M 5.6 OHM, F, 0.33W	1	
	R16102	ERJT06J221V	M 220 OHM, F, 0.25W	1	
	R16109	ERJT06J100V	M 10 OHM, F, 0.25W	1	
	R16110	ERJ6GEYF473	M 47KOHM, J, 1/10W	1	



Safety	Ref. No.	Part No.	Part Name & Description	Pcs	Remarks
	R16116	ERJ6GEYF473	M 47KOHM,J,1/10W	1	
	R16131	DOGD101JA036	M 100 OHM,J,0.25W	1	
	R16132	DOGD101JA036	M 100 OHM,J,0.25W	1	
	R16134	ERJT06J750V	M 75 OHM,F,0.25W	1	
	R16137	ERJT08J1R0V	M 1.8OHM,J,0.33W	1	
	R16138	ERJT08J1R0V	M 1.8OHM,J,0.33W	1	
	R16141	ERJT06J100V	M 10 OHM,F,0.25W	1	
	R16142	ERJ6GEYF473	M 47KOHM,J,1/10W	1	
	R16143	ERJ6GEYF473	M 47KOHM,J,1/10W	1	
	R16151	DOGD101JA036	M 100 OHM,J,0.25W	1	
	R16152	DOGD101JA036	M 100 OHM,J,0.25W	1	
	R16154	ERJT06J750V	M 75 OHM,F,0.25W	1	
	R16155	ERJT08J1R0V	M 1.8OHM,J,0.33W	1	
	R16159	ERJT08J1R0V	M 1.8OHM,J,0.33W	1	
	R16161	ERJT06J100V	M 10 OHM,F,0.25W	1	
	R16162	ERJ6GEYF473	M 47KOHM,J,1/10W	1	
	R16163	ERJ6GEYF473	M 47KOHM,J,1/10W	1	
	R16171	ERJT06J100V	M 10 OHM,F,0.25W	1	
	R16172	ERJ6GEYF473	M 47KOHM,J,1/10W	1	
	R16173	ERJ6GEYF473	M 47KOHM,J,1/10W	1	
	R16181	ERJT06J100V	M 10 OHM,F,0.25W	1	
	R16182	ERJ6GEYF473	M 47KOHM,J,1/10W	1	
	R16183	ERJ6GEYF473	M 47KOHM,J,1/10W	1	
	R16191	DOGD101JA036	M 100 OHM,J,0.25W	1	
	R16192	DOGD101JA036	M 100 OHM,J,0.25W	1	
	R16193	ERJT06J750V	M 75 OHM,F,0.25W	1	
	R16194	ERJT08J1R0V	M 1.8OHM,J,0.33W	1	
	R16195	ERJT08J1R0V	M 1.8OHM,J,0.33W	1	
	R16220	ERJ6GEYJ470V	M 47 OHM,J,1/10W	1	
	R16221	ERJ6GEYJ472V	M 4.7K OHM J 1/10W	1	
	R16230	ERJ6GEYJ470V	M 47 OHM,J,1/10W	1	
	R16231	ERJ6GEYJ472V	M 4.7K OHM J 1/10W	1	
	R16241	EXB38V470J	RESISTOR ARRAY	1	
	R16242	EXB38V472JV	RESISTOR ARRAY	1	
	R16251	ERJ6ENF1201	M 1.2KOHM, 1/10W	1	
	R16252	ERJ6ENF3902	M 39KOHM, 1/10W	1	
	R16253	ERJ6ENF3902	M 39KOHM, 1/10W	1	
	R16254	ERJ6ENF8201	M 8.2KOHM, 1/10W	1	
	R16255	ERJ6ENF1001	M 1KOHM, 1/10W	1	
	R16256	ERJ6ENF1801	M 1.8KOHM, 1/10W	1	
	R16257	DOGD103JA036	M 10KOHM,J,0.25W	1	
	R16258	ERJ6GEYJ222V	M 2.2K OHM J 1/10W	1	
	R16260	ERJ6GEYJ222V	M 2.2K OHM J 1/10W	1	
	R16261	ERJ6GEYJ104V	M 100KOHM,J,1/10W	1	
	R16280	ERJ6GEYJ222V	M 2.2K OHM J 1/10W	1	
	R16281	DOGD103JA036	M 10KOHM,J,0.25W	1	
	R16282	ERJ6GEYJ221V	M 220 OHM,J,1/10W	1	
	R16283	ERJ6GEYF473	M 47KOHM,J,1/10W	1	
	R16284	ERJ6GEYJ224	M 220KOHM,J,1/10W	1	
	R16289	ERJ6GEYJ623V	M 62KOHM,J,1/10W	1	
	R16290	ERJT08J334V	M 330KOHM,F,0.33W	1	
	R16291	ERJ6GEYJ623V	M 62KOHM,J,1/10W	1	
	R16292	ERJT08J334V	M 330KOHM,F,0.33W	1	
	R16300	ERJT08J102V	M 1KOHM,J, 0.33W	1	

Safety	Ref. No.	Part No.	Part Name & Description	Pcs	Remarks
	R16301	ERJ6GEYJ472V	M 4.7K OHM J 1/10W	1	
	R16302	ERJ8GEYJ105V	M 1MOHM, J,1/8W	1	
	R16303	DOGD101JA036	M 100 OHM,J,0.25W	1	
	R16304	ERJT08J681V	M 680 OHM,F,0.33W	1	
	R16305	ERJ6GEYJ271V	M 270 OHM J 1/10W	1	
	R16306	DOGD101JA036	M 100 OHM,J,0.25W	1	
	R16307	DOGD101JA036	M 100 OHM,J,0.25W	1	
	R16308	DOGD101JA036	M 100 OHM,J,0.25W	1	
	R16309	ERJ6GEYJ472V	M 4.7K OHM J 1/10W	1	
	R16310	ERJ6GEYJ562V	M 5.6KOHM,J,1/10W	1	
	R16311	ERJ6GEYJ124V	M 120KOHM,J,1/10W	1	
	R16312	ERJ6GEYJ124V	M 120KOHM,J,1/10W	1	
	R16313	ERJ6ENF4752	M47.5KOHM, 1/10W	1	
	R16314	ERJ6ENF5602	M 56KOHM, 1/10W	1	
	R16315	ERJ6ENF1241	M1.24KOHM, 1/10W	1	
	R16317	DOGDR00Z0002	M 0 OHM, 1/10W	1	
	R16321	ERJ6GEYF473	M 47KOHM,J,1/10W	1	
	R16322	ERJ6GEYF561	M 560 OHM,F,1/10W	1	
	R16323	ERJ6GEYJ223	M 22KOHM,J,1/10W	1	
	R16324	DOGD103JA036	M 10KOHM,J,0.25W	1	
	R16325	DOGDR00Z0002	M 0 OHM, 1/10W	1	
	R16331	ERJT06J101V	M 100 OHM,F,0.25W	1	
	R16333	ERJ6ENF3303	M 330KOHM, 1/10W	1	
	R16334	ERJT06J101V	M 100 OHM,F,0.25W	1	
	R16336	ERJT08J1R0V	M 1.8OHM,J,0.33W	1	
	R16338	ERJT06J101V	M 100 OHM,F,0.25W	1	
	R16339	ERJ6ENF3303	M 330KOHM, 1/10W	1	
	R16340	ERJT06J152V	M 1.5KOHM,F,0.25W	1	
	R16401	ERJT08J7R5V	M 7.5OHM,J,0.33W	1	
	R16404	ERJT08J7R5V	M 7.5OHM,J,0.33W	1	
	R16421	ERJT08J7R5V	M 7.5OHM,J,0.33W	1	
	R16422	ERJT08J7R5V	M 7.5OHM,J,0.33W	1	
	R16441	ERJT08J5R6V	M 5.6 OHM,F,0.33W	1	
	R16451	ERJT08J5R6V	M 5.6 OHM,F,0.33W	1	
	R16465	ERJ6ENF2702	M 27KOHM, 1/10W	1	
	R16466	ERJ6ENF5602	M 56KOHM, 1/10W	1	
	R16467	ERJ6ENF8202	M 82KOHM, 1/10W	1	
	R16468	ERJ6ENF8202	M 82KOHM, 1/10W	1	
	R16471	ERJ6GEYJ392	M 3.9KOHM,J,1/10W	1	
	R16472	ERJ6GEYJ222V	M 2.2K OHM J 1/10W	1	
	R16473	ERJ6GEYF561	M 560 OHM,F,1/10W	1	
	R16474	ERJ6GEYJ102V	M 1K OHM J 1/10W	1	
	R16475	ERJ6GEYJ472V	M 4.7K OHM J 1/10W	1	
	R16476	ERJ6GEYJ472V	M 4.7K OHM J 1/10W	1	
	R16477	DOGBR00Z0002	M 0 OHM J 1/16W	1	
	R16478	ERJ6GEYJ562V	M 5.6KOHM,J,1/10W	1	
	R16479	DOGD103JA036	M 10KOHM,J,0.25W	1	
	R16480	ERJ6GEYJ472V	M 4.7K OHM J 1/10W	1	

Safety	Ref. No.	Part No.	Part Name & Description	Pcs	Remarks
	R16501	DOGD101JA036	M 100 OHM,J,0.25W	1	
	R16502	DOGD101JA036	M 100 OHM,J,0.25W	1	
	R16503	ERJT06J100V	M 10 OHM,F,0.25W	1	
	R16504	ERJT06J750V	M 75 OHM,F,0.25W	1	
	R16506	ERJT06J100V	M 10 OHM,F,0.25W	1	
	R16507	ERJT08J1R0V	M 1.8OHM,J,0.33W	1	
	R16508	ERJT08J1R0V	M 1.8OHM,J,0.33W	1	
	R16509	ERJT08J1R0V	M 1.8OHM,J,0.33W	1	
	R16510	ERJT08J1R0V	M 1.8OHM,J,0.33W	1	
	R16511	ERJ6GEYF473	M 47KOHM,J,1/10W	1	
	R16512	ERJ6GEYF473	M 47KOHM,J,1/10W	1	
	R16516	ERJ6GEYF473	M 47KOHM,J,1/10W	1	
	R16517	ERJ6GEYF473	M 47KOHM,J,1/10W	1	
	R16521	DOGD101JA036	M 100 OHM,J,0.25W	1	
	R16522	DOGD101JA036	M 100 OHM,J,0.25W	1	
	R16523	ERJT06J750V	M 75 OHM,F,0.25W	1	
	R16531	ERJT06J100V	M 10 OHM,F,0.25W	1	
	R16532	ERJ6GEYF473	M 47KOHM,J,1/10W	1	
	R16533	ERJ6GEYF473	M 47KOHM,J,1/10W	1	
	R16551	ERJT06J100V	M 10 OHM,F,0.25W	1	
	R16552	ERJ6GEYF473	M 47KOHM,J,1/10W	1	
	R16553	ERJ6GEYF473	M 47KOHM,J,1/10W	1	
	R16561	EXB38V470J	RESISTOR ARRAY	1	
	R16562	EXB38V470J	RESISTOR ARRAY	1	
	R16563	EXB38V470J	RESISTOR ARRAY	1	
	R16564	EXB38V470J	RESISTOR ARRAY	1	
	R16565	EXB38V472JV	RESISTOR ARRAY	1	
	R16566	EXB38V472JV	RESISTOR ARRAY	1	
	R16567	EXB38V472JV	RESISTOR ARRAY	1	
	R16568	EXB38V472JV	RESISTOR ARRAY	1	
	R16580	ERJ6GEYJ222V	M 2.2K OHM J 1/10W	1	
	R16582	ERJ6ENF3902	M 39KOHM, 1/10W	1	
	R16583	ERJ6ENF3902	M 39KOHM, 1/10W	1	
	R16584	ERJ6ENF8201	M 8.2KOHM, 1/10W	1	
	R16585	ERJ6ENF1001	M 1KOHM, 1/10W	1	
	R16586	ERJ6ENF1801	M 1.8KOHM, 1/10W	1	
	R16587	ERJ6GEYJ222V	M 2.2K OHM J 1/10W	1	
	R16588	DOGD103JA036	M 10KOHM,J,0.25W	1	
	R16590	ERJ6GEYJ221V	M 220 OHM,J,1/10W	1	
	R16591	EXB38V472JV	RESISTOR ARRAY	1	
	R16592	ERJ6GEYJ472V	M 4.7K OHM J 1/10W	1	
	R16593	ERJ6ENF1201	M 1.2KOHM, 1/10W	1	
	R16600	DOGD103JA036	M 10KOHM,J,0.25W	1	
	R16601	ERJ6GEYJ472V	M 4.7K OHM J 1/10W	1	
	R16602	ERJ6GEYJ102V	M 1K OHM J 1/10W	1	
	R16603	ERJ6GEYJ331V	M 330 OHM J 1/10W	1	
	R16604	ERJ6GEYJ331V	M 330 OHM J 1/10W	1	
	R16605	ERJ6GEYG182	M 1.8KOHM,J,1/10W	1	
	R16606	DOGD103JA036	M 10KOHM,J,0.25W	1	
	R16607	ERJ6ENF6651	M6.65KOHM, 1/10W	1	
	R16608	ERJT08J102V	M 1KOHM,J, 0.33W	1	
	R16609	ERJT08J102V	M 1KOHM,J, 0.33W	1	
	R16610	ERJ6GEYJ104V	M 100KOHM,J,1/10W	1	
	R16611	ERG2FJS473D	M 47KOHM, J, 2W	1	
	R16612	ERJT06J470V	M 47 OHM,F,0.25W	1	
	R16613	ERG1FJS104D	M 100KOHM, J, 1W	1	
	R16615	ERJ6ENF1131	M1.13KOHM, 1/10W	1	
	R16616	DOGDR00Z0002	M 0 OHM, 1/10W	1	

Safety	Ref. No.	Part No.	Part Name & Description	Pcs	Remarks
	R16617	ERJ6GEYJ222V	M 2.2K OHM J 1/10W	1	
	R16622	ERJ6GEYJ221V	M 220 OHM,J,1/10W	1	
	R16623	ERJ6GEYJ221V	M 220 OHM,J,1/10W	1	
	R16632	DOGD103JA036	M 10KOHM,J,0.25W	1	
	R16633	ERJ6GEYJ223	M 22KOHM,J,1/10W	1	
	R16634	ERJ6GEYJ471	M 470 OHM,J,1/10W	1	
	R16635	DOGD103JA036	M 10KOHM,J,0.25W	1	
	R16636	ERJ6GEYJ472V	M 4.7K OHM J 1/10W	1	
	R16638	ERJT08J1R0V	M 1.8OHM,J,0.33W	1	
	R16639	ERJT08J1R0V	M 1.8OHM,J,0.33W	1	
	R16642	ERJT06J330V	M 33 OHM,F,0.25W	1	
	R16643	ERJT06J330V	M 33 OHM,F,0.25W	1	
	R16645	ERJT06J330V	M 33 OHM,F,0.25W	1	
	R16657	ERJ6GEYG682	M 6.8KOHM,J,1/10W	1	
	R16658	DOD1101JA009	M 100 OHM,J,1W	1	
	R16659	ERJ6GEYJ224	M 220KOHM,J,1/10W	1	
	R16660	ERJ6GEYJ224	M 220KOHM,J,1/10W	1	
	R16661	ERJ6GEYG182	M 1.8KOHM,J,1/10W	1	
	R16662	ERJ6ENF3001	M 3KOHM, 1/10W	1	
	R16663	DOGD103JA036	M 10KOHM,J,0.25W	1	
	R16664	ERJT08J102V	M 1KOHM,J, 0.33W	1	
	R16665	ERJT06J330V	M 33 OHM,F,0.25W	1	
	R16666	ERJ6GEYJ104V	M 100KOHM,J,1/10W	1	
	R16667	ERJ6GEYJ471	M 470 OHM,J,1/10W	1	
	R16668	ERJ6GEYF473	M 47KOHM,J,1/10W	1	
	R16669	ERJ6GEYJ472V	M 4.7K OHM J 1/10W	1	
	R16670	ERJT06J470V	M 47 OHM,F,0.25W	1	
	R16671	ERJ6GEYF473	M 47KOHM,J,1/10W	1	
	R16672	ERJ6GEYJ102V	M 1K OHM J 1/10W	1	
	R16675	ERJT08J102V	M 1KOHM,J, 0.33W	1	
	R16681	ERJT06J100V	M 10 OHM,F,0.25W	1	
	R16682	ERJT06J100V	M 10 OHM,F,0.25W	1	
	R16696	ERF5TK2R2	W 2.2 OHM, K, 5W	1	
	R16700	ERJ6GEYJ472V	M 4.7K OHM J 1/10W	1	
	R16701	DOGD103JA036	M 10KOHM,J,0.25W	1	
	R16702	ERJ6GEYJ332V	M 3.3K OHM J 1/10W	1	
	R16703	DOGD103JA036	M 10KOHM,J,0.25W	1	
	R16704	DOGD103JA036	M 10KOHM,J,0.25W	1	
	R16705	DOGD101JA036	M 100 OHM,J,0.25W	1	
	R16706	DOGD101JA036	M 100 OHM,J,0.25W	1	
	R16707	ERJ6GEYJ471	M 470 OHM,J,1/10W	1	
	R16717	ERJ6GEYJ222V	M 2.2K OHM J 1/10W	1	
	R16720	ERJ3GEYJ220	M 22 OHM,J,1/16W	1	
	R16721	ERJ3GEYJ220	M 22 OHM,J,1/16W	1	
	R16722	ERJ3GEYJ220	M 22 OHM,J,1/16W	1	
	R16723	ERJ3GEYJ220	M 22 OHM,J,1/16W	1	
	R16729	ERJ6GEYF473	M 47KOHM,J,1/10W	1	
	R16730	ERJ6GEYF473	M 47KOHM,J,1/10W	1	
	R16731	ERG1FJS823D	M 82KOHM, J, 1W	1	
	R16732	ERJ6GEYG392	M 3.9KOHM,J,1/10W	1	
	R16733	ERJ6GEYJ474	M 470KOHM,J,1/10W	1	
	R16734	ERJ6ENF4991	M4.99KOHM, 1/10W	1	
	R16735	ERJ6ENF2213	M 221KOHM, 1/10W	1	
	R16736	ERJ6ENF2213	M 221KOHM, 1/10W	1	
	R16737	ERJ6ENF2003	M 200KOHM, 1/10W	1	

Safety	Ref. No.	Part No.	Part Name & Description	Pcs	Remarks
	R16738	ERGLFJS823D	M 82KOHM, J, 1W	1	
	R16740	ERJ6GEYJ104V	M 100KOHM, J, 1/10W	1	
	R16744	ERJ6ENF2003	M 200KOHM, 1/10W	1	
	R16749	DOGD103JA036	M 10KOHM, J, 0.25W	1	
	R16750	ERJT06J223V	M 22 KOHM, F, 0.25W	1	
	R16751	ERJT06J224V	M 220KOHM, F, 0.25W	1	
	R16752	ERJ6GEYJ472V	M 4.7K OHM J 1/10W	1	
	R16753	ERJ6GEYF473	M 47KOHM, J, 1/10W	1	
	R16756	ERJT06J223V	M 22 KOHM, F, 0.25W	1	
	R16757	DOGDR00Z0002	M 0 OHM, 1/10W	1	
	R16761	ERJT06J100V	M 10 OHM, F, 0.25W	1	
	R16762	ERJ6GEYF473	M 47KOHM, J, 1/10W	1	
	R16765	ERJT08J1R0V	M 1.8OHM, J, 0.33W	1	
	R16766	ERJT06J750V	M 75 OHM, F, 0.25W	1	
	R16768	ERJT08J1R0V	M 1.8OHM, J, 0.33W	1	
	R16769	ERJT06J750V	M 75 OHM, F, 0.25W	1	
	R16771	ERJ6GEYJ182	M 1.8KOHM, J, 1/10W	1	
	R16774	ERGLSJ683	M 68KOHM, J, 1W	1	
	R16775	ERJ6GEYJ472V	M 4.7K OHM J 1/10W	1	
	R16776	DOGD101JA036	M 100 OHM, J, 0.25W	1	
	R16777	ERJT06J151V	M 150 OHM, F, 0.25W	1	
	R16778	ERJ6GEYJ182	M 1.8KOHM, J, 1/10W	1	
	R16781	ERJT06J470V	M 47 OHM, F, 0.25W	1	
	R16782	ERJ6GEYF473	M 47KOHM, J, 1/10W	1	
	R16785	ERJ6ENF8202	M 82KOHM, 1/10W	1	
	R16786	ERJ6ENF8202	M 82KOHM, 1/10W	1	
	R16787	ERJ6ENF3302	M 33KOHM, 1/10W	1	
	R16788	ERJT06J154V	M 150KOHM, F, 0.25W	1	
	R16789	DOGD103JA036	M 10KOHM, J, 0.25W	1	
	R16794	ERJ6ENF2003	M 200KOHM, 1/10W	1	
	R16795	ERJ6ENF2003	M 200KOHM, 1/10W	1	
	R16796	ERJ6ENF5602	M 56KOHM, 1/10W	1	
	R16822	ERJ6ENF8202	M 82KOHM, 1/10W	1	
	R16823	ERJ6ENF8202	M 82KOHM, 1/10W	1	
	R16824	ERJ6ENF3302	M 33KOHM, 1/10W	1	
	R16825	ERJT06J154V	M 150KOHM, F, 0.25W	1	
	R16826	DOGD103JA036	M 10KOHM, J, 0.25W	1	
	R16827	DOGDR00Z0002	M 0 OHM, 1/10W	1	
	R16838	ERJ14YJ563U	M 56KOHM, 1/2W	1	
	R16841	ERJ14YJ563U	M 56KOHM, 1/2W	1	
	R16844	ERJ6ENF1241	M 1.24KOHM, 1/10W	1	
	R16845	ERJ6ENF6202	M 62KOHM, 1/10W	1	
	R16846	ERJ6ENF6042	M 60.4KOHM, 1/10W	1	
	R16850	ERJ6GEYJ472V	M 4.7K OHM J 1/10W	1	
	R16851	ERJ6GEYJ104V	M 100KOHM, J, 1/10W	1	
	R16852	DOGD103JA036	M 10KOHM, J, 0.25W	1	
	R16855	ERGLFJS103D	M 10KOHM, J, 1W	1	
	R16856	ERQ12AJW560E	F 56 OHM, J, 1/2W	1	
	R16857	ERJ12YJ124U	M 120KOHM, 1/2W	1	
	R16858	ERJ6ENF2700	M 270 OHM, 1/10W	1	
	R16860	DOD28R2JA021	M 8.2 OHM, J, 2W	1	
	R16870	ERG2FJS333D	M 33KOHM, J, 2W	1	
	R16871	ERJ6GEYJ392	M 3.9KOHM, J, 1/10W	1	
	R16872	ERJ6GEYJ332V	M 3.3K OHM J 1/10W	1	
	R16873	ERJ6ENF2491	M 2.49KOHM, 1/10W	1	
	R16874	ERJ6ENF7322	M 73.2KOHM, 1/10W	1	PAVCSG
	R16875	ERJ6ENF7152	M 71.5KOHM, 1/10W	1	
	R16886	ERJ6GEYJ224	M 220KOHM, J, 1/10W	1	

Safety	Ref. No.	Part No.	Part Name & Description	Pcs	Remarks
	R16887	ERJ6GEYJ224	M 220KOHM, J, 1/10W	1	
	R16888	ERJ6GEYJ224	M 220KOHM, J, 1/10W	1	
	R17119	EXB38V220JV	RESISTOR ARRAY	1	
	R17121	EXB38V471J	RESISTOR ARRAY	1	
	R17122	EXB38V471J	RESISTOR ARRAY	1	
	R17123	ERJ3GEYJ471	M 470 OHM, J, 1/16W	1	
	R17124	ERJ3GEYJ471	M 470 OHM, J, 1/16W	1	
	R17126	DOGZ6R8JA020	M 6.8 OHM, J, 0.5W	1	
	R17127	DOGZ6R8JA020	M 6.8 OHM, J, 0.5W	1	
	R17131	EXB38V471J	RESISTOR ARRAY	1	
	R17132	EXB38V471J	RESISTOR ARRAY	1	
	R17133	ERJ3GEYJ471	M 470 OHM, J, 1/16W	1	
	R17134	ERJ3GEYJ471	M 470 OHM, J, 1/16W	1	
	R17136	DOGZ6R8JA020	M 6.8 OHM, J, 0.5W	1	
	R17137	DOGZ6R8JA020	M 6.8 OHM, J, 0.5W	1	
	R17141	EXB38V471J	RESISTOR ARRAY	1	
	R17142	EXB38V471J	RESISTOR ARRAY	1	
	R17146	DOGZ6R8JA020	M 6.8 OHM, J, 0.5W	1	
	R17147	DOGZ6R8JA020	M 6.8 OHM, J, 0.5W	1	
	R17151	EXB38V471J	RESISTOR ARRAY	1	
	R17152	EXB38V471J	RESISTOR ARRAY	1	
	R17155	EXB38V102J	RESISTOR ARRAY	1	
	R17156	DOGZ6R8JA020	M 6.8 OHM, J, 0.5W	1	
	R17157	DOGZ6R8JA020	M 6.8 OHM, J, 0.5W	1	
	R17159	EXB38V470J	RESISTOR ARRAY	1	
	R17161	DOGDR00Z0002	M 0 OHM, 1/10W	1	
	R17177	EXB38V102J	RESISTOR ARRAY	1	
	R17180	ERJ3GEYJ470	M 47 OHM, J, 1/16W	1	
	R17184	EXB38V470J	RESISTOR ARRAY	1	
	R17185	DOGB102JA041	M 1KOHM, J, 1/16W	1	
	R17191	DOGF472JA047	M 4.7KOHM, J, 0.33W	1	
	R17192	ERJ6GEYJ224	M 220KOHM, J, 1/10W	1	
	R17212	EXB38V471J	RESISTOR ARRAY	1	
	R17216	DOGZ6R8JA020	M 6.8 OHM, J, 0.5W	1	
	R17217	DOGZ6R8JA020	M 6.8 OHM, J, 0.5W	1	
	R17219	ERJ6GEYJ224	M 220KOHM, J, 1/10W	1	
	R17221	EXB38V471J	RESISTOR ARRAY	1	
	R17222	EXB38V471J	RESISTOR ARRAY	1	
	R17223	DOGZ6R8JA020	M 6.8 OHM, J, 0.5W	1	
	R17224	DOGZ6R8JA020	M 6.8 OHM, J, 0.5W	1	
	R17226	DOGZ6R8JA020	M 6.8 OHM, J, 0.5W	1	
	R17227	DOGZ6R8JA020	M 6.8 OHM, J, 0.5W	1	
	R17231	EXB38V471J	RESISTOR ARRAY	1	
	R17232	EXB38V471J	RESISTOR ARRAY	1	
	R17233	ERJ3GEYJ471	M 470 OHM, J, 1/16W	1	
	R17234	ERJ3GEYJ471	M 470 OHM, J, 1/16W	1	
	R17236	DOGZ6R8JA020	M 6.8 OHM, J, 0.5W	1	
	R17237	DOGZ6R8JA020	M 6.8 OHM, J, 0.5W	1	
	R17238	EXB38V471J	RESISTOR ARRAY	1	
	R17243	ERJ3GEYJ471	M 470 OHM, J, 1/16W	1	

Safety	Ref. No.	Part No.	Part Name & Description	Pcs	Remarks
	R17244	ERJ3GEYJ471	M 470 OHM,J,1/16W	1	
	R17245	EXB38V102J	RESISTOR ARRAY	1	
	R17249	EXB38V220JV	RESISTOR ARRAY	1	
	R17250	EXB38V470J	RESISTOR ARRAY	1	
	R17257	ERJ3GEYJ470	M 47 OHM,J,1/16W	1	
	R17258	EXB38V102J	RESISTOR ARRAY	1	
	R17261	DOGDR00Z0002	M 0 OHM, 1/10W	1	
	R17269	DOGF472JA047	M 4.7KOHM,J,0.33W	1	
	R17278	EXB38V471J	RESISTOR ARRAY	1	
	R17279	EXB38V471J	RESISTOR ARRAY	1	
	R17280	DOGB102JA041	M 1KOHM,J,1/16W	1	
	R17281	ERJ6GEYJ102V	M 1K OHM J 1/10W	1	
	R17285	EXB38V220JV	RESISTOR ARRAY	1	
	R17288	EXB38V222J	RESISTOR ARRAY	1	
	R17289	EXB38V222J	RESISTOR ARRAY	1	
	R17290	EXB38V470J	RESISTOR ARRAY	1	
	R17291	EXB38V470J	RESISTOR ARRAY	1	
	RM2501	PNA4701M07TV	REMOCON RECEIVER	1	
	S1	K1KA03BA0061	3P CONNECTOR	1	
	SC2	K1KA02A00676	2P CONNECTOR	1	
	SC20	K1MN30BA0255	30P CONNECTOR	1	
	SC30	K1KA08AA0190	8P CONNECTOR	1	
	SC41	K1KA23AA0733	23P CONNECTOR	1	
	SC42	K1KA23AA0733	23P CONNECTOR	1	
	SC46	K1KA09AA0707	9P CONNECTOR	1	
	SCMM1	TMME047	CLAMPER	1	
	SD11	K1MN20BA0231	20P CONNECTOR	1	
	SD42	K1KB23AA0234	23P CONNECTOR	1	
	SD46	K1KB09AA0219	9P CONNECTOR	1	
	SD1B	K1MN96B00005	96P CONNECTOR	1	
	SD2B	K1MN96B00005	96P CONNECTOR	1	
	SD3B	K1MN96B00005	96P CONNECTOR	1	
	SD4B	K1MN96B00005	96P CONNECTOR	1	
	SS11	K1KA02A00676	2P CONNECTOR	1	
	SS12	K1KA10AA0194	10P CONNECTOR	1	
	SS23	K1KA12AA0194	12P CONNECTOR	1	
	SS34	K1KA03AA0193	3P CONNECTOR	1	
	SS53A	K1MN13B00091	13P CONNECTOR	1	
	SS56A	K1MN13B00091	13P CONNECTOR	1	
	SSMM2	TMM17434-2	CLAMPER	1	
	SSMM3	TMM7464-2	CLAMPER	1	
	SSMM4	TMM7464-2	CLAMPER	1	
	SU11	K1MN20BA0266	20P CONNECTOR	1	
	SU41	K1KB23AA0234	23P CONNECTOR	1	
	SU1B	K1MN96B00005	96P CONNECTOR	1	
	SU2B	K1MN96B00005	96P CONNECTOR	1	
	SU4B	K1MN96B00005	96P CONNECTOR	1	
	SU3B	K1MN96B00005	96P CONNECTOR	1	
△	SW2500	K0F162B00002	SWITCH	1	
	SW3753	EVQPC105K	SWITCH	1	
	SW3754	EVQPC105K	SWITCH	1	
	SW3755	EVQPC105K	SWITCH	1	
	SW3756	EVQPC105K	SWITCH	1	
	SW3757	EVQPC105K	SWITCH	1	
	TI6301A	ETS19AB249AC	SWITCHING TRANS	1	
△	TU8301A	ENG39E04GF	TUNER	1	
	VR16000	EVMEASA00B54	CONTROL 50KOHMB 0.3W	1	
	VR16600	EVMEASA00B54	CONTROL 50KOHMB 0.3W	1	

Safety	Ref. No.	Part No.	Part Name & Description	Pcs	Remarks
	VR16602	EVMEASA00B33	CONTROL 3KOHMB 0.3W	1	
	X1100	HOJ100500035	CRYSTAL	1	
	X2010	HOJ245500089	CRYSTAL	1	
	X8001	HOJ270500061	CRYSTAL	1	
	X9900	HOJ200500076	CRYSTAL	1	
	ZA0001	K4AZ01D00004	TERMINAL	1	
	ZA0002	K4AZ01D00004	TERMINAL	1	
	ZA0003	K4AZ01D00004	TERMINAL	1	
	ZA0004	K4AZ01D00004	TERMINAL	1	
	ZA0007	K4AZ01D00004	TERMINAL	1	
	ZA0008	K4AZ01D00004	TERMINAL	1	
	ZA3701	K4CZ01000027	AV TERMINAL	1	
	ZA14901	K4AD01Z00003	TERMINAL	1	
	ZA14902	K4AD01Z00003	TERMINAL	1	
	ZA14951	K4AD01Z00003	TERMINAL	1	
	ZA14952	K4AD01Z00003	TERMINAL	1	
	ZA16001	K4CD01000011	AV TERMINAL	1	
	ZA16002	K4CD01000011	AV TERMINAL	1	
	ZA16003	K4CD01000011	AV TERMINAL	1	
	ZA16401	K4CD01000011	AV TERMINAL	1	
	ZA16402	K4CD01000011	AV TERMINAL	1	
	ZA16403	K4CD01000011	AV TERMINAL	1	
	ZA17101	K4AD01Z00001	TERMINAL	1	
	ZA17102	K4AD01Z00001	TERMINAL	1	
	ZA17103	K4AD01Z00001	TERMINAL	1	
	ZA17104	K4AD01Z00001	TERMINAL	1	
	ZA17201	K4AD01Z00001	TERMINAL	1	
	ZA17202	K4AD01Z00001	TERMINAL	1	
	ZA17203	K4AD01Z00001	TERMINAL	1	
	ZA17204	K4AD01Z00001	TERMINAL	1	
	C404	ECQU2A104MLA	P 0.1UF, M, 250V	1	
	C405	FOCZZ2250001	P 0.022UF, 200V	1	
	C406	F1E2J4730001	C 0.047PF, , 600V	1	
△	C407	F2B2W220A032	C 22UF, 450V	1	
	C408	ECJ1VB1H102K	C 1000PF, K, 50V	1	
	C409	FOCZZ2250001	P 0.022UF, 200V	1	
	C413	ECJ1VB1E104K	C 0.10UF, K, 25V	1	
	C420	FLJ1E105A080	C 1 UF 25V	1	
	C421	ECJ1VB1E104K	C 0.10UF, K, 25V	1	
	C423	ECJ1VB1H472K	C 4700PF, K, 50V	1	
	C425	FLJ1E105A080	C 1 UF 25V	1	
	C426	F1H1H471A792	E 470UF, 50V	1	
	C427	F1H1C105A071	C 1UF, K, 16V	1	
	C428	F1H1H221A792	E 220UF, 50V	1	
	C429	F1E2J4730001	C 0.047PF, , 600V	1	
	C431	ECJ1VB1H102K	C 1000PF, K, 50V	1	
	C432	F1H1C105A071	C 1UF, K, 16V	1	
	C433	F1H1C105A071	C 1UF, K, 16V	1	
	C436	F1H1C105A071	C 1UF, K, 16V	1	
	C437	ECJ1VB1H103K	C 0.001UF, K, 50V	1	
	C443	ECKD3A102KBP	C 1000PF, K, 1KV	1	
	C444	ECKD3A102KBP	C 1000PF, K, 1KV	1	
	C445	F1H1C105A071	C 1UF, K, 16V	1	
△	C446	F2B2W3910010	C 390UF, 450V	1	
	C450	ECJ1VB1H103K	C 0.001UF, K, 50V	1	
	C451	ECKD3A101KBP	C 100PF, K, 1KV	1	
	C457	ECWH12333RHV	P 0.013UF,J,1.2KV	1	
	C462	FLJ1E225A209	C 2.2 UF 25V	1	
	C463	F1H1H2200008	E 22UF, 50V	1	
△	C467	F1BAF221A107	C 220UF, 250V	1	
△	C469	F1BAF221A107	C 220UF, 250V	1	
△	C470	ECQU2A225MLA	C 22UF, 450V	1	
△	C472	F1BAF221A107	C 220UF, 250V	1	
△	C474	F1BAF221A107	C 220UF, 250V	1	

Safety	Ref. No.	Part No.	Part Name & Description	Pcs	Remarks
△	C475	F1BAF221A107	C 220UF, 250V	1	
△	C478	F1BAF221A107	C 220UF, 250V	1	
	C492	F2A1H1000083	E 10UF, 50V	1	
	C493	F2A1H4700057	E 47UF, 50V	1	
	C497	F2A1H4700057	E 47UF, 50V	1	
	C501	ECJ1VB1H103K	C 0.001UF, K, 50V	1	
	C502	ECJ1VB1H103K	C 0.001UF, K, 50V	1	
	C504	F1H1C105A071	C 1UF, K, 16V	1	
	C505	ECJ1VB1H102K	C 1000PF, K, 50V	1	
	C506	ECJ1VB1H103K	C 0.001UF, K, 50V	1	
	C507	ECJ1VB1E104K	C 0.10UF, K, 25V	1	
	C509	ECA1EHG101	E 100UF, 25V	1	
	C511	ECJ1VB1H102K	C 1000PF, K, 50V	1	
	C515	F2A1A1220015	E 1200UF, 10V	1	
	C516	ECJ1VC1H330J	C 33PF, J, 50V	1	
	C517	F2A1E221A096	E 220UF, 25V	1	
	C518	F1H1C105A071	C 1UF, K, 16V	1	
	C519	F1H1C105A071	C 1UF, K, 16V	1	
	C520	FOC2E683A160	E 0.068UF, 250V	1	
	C521	ECJ1VB1H103K	C 0.001UF, K, 50V	1	
	C522	F1E2E1030002	C 0.010PF, , 600V	1	
	C523	F1J1E105A080	C 1 UF 25V	1	
	C526	F1H1H223A219	E 0.022UF, 50V	1	
	C528	ECJ1VB1H102K	C 1000PF, K, 50V	1	
	C529	F1J1C475A170	C 4.7UF, K, 16V	1	
	C530	ECJ1VB1C333K	C 0.033UF, K, 16V	1	
	C531	ECJ1VB1E104K	C 0.10UF, K, 25V	1	
	C534	F1H1H471A792	E 470UF, 50V	1	
	C546	ECJ1VB1H102K	C 1000PF, K, 50V	1	
	C547	ECJ1VB1H102K	C 1000PF, K, 50V	1	
	C552	ECJ1VB1E104K	C 0.10UF, K, 25V	1	
	C554	F1H1C105A071	C 1UF, K, 16V	1	
△	C555	F2A2C4710003	E 470UF, 160V	1	
	C556	F2A1E3320040	E 3300PF, 25V	1	
	C558	F2A1E471A096	E 470UF, 25V	1	
	C559	F2A1A1020085	E 1000UF, 10V	1	
	C571	ECJ1VC1H330J	C 33PF, J, 50V	1	
	C574	ECJ1VB1E104K	C 0.10UF, K, 25V	1	
△	C577	F2A2A330A022	E 33UF, 100V	1	
	C581	ECJ2VB1H223K	C 0.022UF, K, 50V	1	
	C583	ECJ1VB1H102K	C 1000PF, K, 50V	1	
	C584	ECJ2VB1H223K	C 0.022UF, K, 50V	1	
	C585	F1H1H223A219	E 0.022UF, 50V	1	
	C587	ECJ1VB1H332K	C 3300PF, K, 50V	1	
	C590	ECJ1XB1H104K	C 10PF, J, 50V	1	
	C603	F1J1E105A080	C 1 UF 25V	1	
△	C604	F2A2D1510008	E 150UF, 200V	1	
△	C605	F2A2D1510008	E 150UF, 200V	1	
	C607	F1H1C105A071	C 1UF, K, 16V	1	
	C610	F1J1E105A080	C 1 UF 25V	1	
△	C611	F2B2T1420004	E 142UF, 220V	1	
	C612	ECJ1VB1H103K	C 0.001UF, K, 50V	1	
	C616	ECKD3A102KBP	C 1000PF, K, 1KV	1	
	C619	ECJ1VB1C474K	C 0.47UF, K, 16V	1	
	C620	F1J1E105A080	C 1 UF 25V	1	
	C623	F2A1H1000083	E 10UF, 50V	1	
	C624	ECJ1VB1H103K	C 0.001UF, K, 50V	1	
	C625	F2A1H1000083	E 10UF, 50V	1	
	C626	ECJ1VB1H103K	C 0.001UF, K, 50V	1	
	C630	ECJ1VB1H103K	C 0.001UF, K, 50V	1	
	C631	ECJ1VB1H103K	C 0.001UF, K, 50V	1	
	C632	ECJ2XC1H330J	C 33PF, J, 50V	1	

Safety	Ref. No.	Part No.	Part Name & Description	Pcs	Remarks
	C639	ECJ1VB1H103K	C 0.001UF, K, 50V	1	
	C640	ECJ1VC1H330J	C 33PF, J, 50V	1	
	C650	ECJ1VB1E104K	C 0.10UF, K, 25V	1	
	C651	ECJ1VB1E104K	C 0.10UF, K, 25V	1	
	C653	ECJ1VB1H102K	C 1000PF, K, 50V	1	
	C657	ECJ1VB1H102K	C 1000PF, K, 50V	1	
	C658	F1J1E105A080	C 1 UF 25V	1	
	C660	F1J1C225A201	C 2.2UF, K, 16V	1	
	C661	ECJ1VB1H103K	C 0.001UF, K, 50V	1	
	C662	ECJ2VB1H103K	C 0.01UF, K, 50V	1	
	C663	ECJ1VB1H103K	C 0.001UF, K, 50V	1	
	C665	ECJ1XC1H101J	C 100PF, J, 50V	1	
	C666	ECJ1VB1H103K	C 0.001UF, K, 50V	1	
	C667	ECJ1VB1H102K	C 1000PF, K, 50V	1	
	C668	ECJ1VB1H102K	C 1000PF, K, 50V	1	
	C669	ECJ1VB1H103K	C 0.001UF, K, 50V	1	
	C670	ECJ1VB1E104K	C 0.10UF, K, 25V	1	
	C671	F1J1A106A079	C 0.010UF, K, 10V	1	
	C672	ECJ1VB1E104K	C 0.10UF, K, 25V	1	
△	D401	B0FBAT000006	DIODE	1	
△	D404	B0EBKT000007	DIODE	1	
	D407	B0ACDJ000010	DIODE	1	
	D408	B0ACDJ000010	DIODE	1	
	D411	B0BB17000009	ZENER DIODE	1	
	D415	B0JAME000099	DIODE	1	
	D416	B0HAMP000067	DIODE	1	
	D417	B0HAPR000012	DIODE	1	
	D418	B0BC8R100013	ZENER DIODE	1	
	D419	B0HAPR000013	DIODE	1	
	D420	B0HAPR000013	DIODE	1	
	D423	MA188	DIODE	1	
	D425	MA188	DIODE	1	
	D429	B0EAKT000048	DIODE	1	
	D431	B0JCDD000002	DIODE	1	
	D433	B0BC01400033	ZENER DIODE	1	
	D435	B0EAKT000048	DIODE	1	
	D436	MA165TA5	DIODE	1	
	D438	B0BC02000014	ZENER DIODE	1	
	D439	B0EAKT000048	DIODE	1	
	D441	B0HAMM000122	DIODE	1	
	D444	B0HAMM000122	DIODE	1	
	D445	MTZJ10B	ZENER DIODE	1	
	D450	B0ACDJ000010	DIODE	1	
	D501	B0HAPR000012	DIODE	1	
	D502	B0BC8R100013	ZENER DIODE	1	
	D503	MA165TA5	DIODE	1	
	D504	MA165TA5	DIODE	1	
	D506	B0ACDJ000010	DIODE	1	
	D509	B0JANG000018	DIODE	1	
	D511	B0JAML000011	DIODE	1	
	D512	B0ACDJ000010	DIODE	1	
	D513	B0ACDJ000010	DIODE	1	
	D516	B0BA03300004	ZENER DIODE	1	
	D517	B0BA03300004	ZENER DIODE	1	
	D518	B0BA03300004	ZENER DIODE	1	
	D520	B0ACDJ000010	DIODE	1	
	D521	B0JAME000099	DIODE	1	
	D522	B0JCDD000002	DIODE	1	
	D523	B0JCDD000002	DIODE	1	
	D530	B0ACDJ000010	DIODE	1	
	D531	B0HBSN000013	DIODE	1	
	D535	MA188	DIODE	1	
	D536	MA3DD82	DIODE	1	
	D538	B0BC5R100039	ZENER DIODE	1	
	D539	B0HARR000019	DIODE	1	
	D540	B0HARR000019	DIODE	1	
	D543	B0BC01400033	ZENER DIODE	1	

Safety	Ref. No.	Part No.	Part Name & Description	Pcs	Remarks
	D544	B0BA02100001	ZENER DIODE	1	
	D545	B0BA02100001	ZENER DIODE	1	
	D546	B0BA02800001	ZENER DIODE	1	
	D549	B0BC02500008	ZENER DIODE	1	
	D569	B0BA05100010	ZENER DIODE	1	
	D570	B0BA05100010	ZENER DIODE	1	
	D579	MA165TA5	DIODE	1	
	D582	MAZ705600F	ZENER DIODE	1	
	D584	MAZ706200F	ZENER DIODE	1	
	D586	BOHAMP000067	DIODE	1	
	D598	B0BC5R100039	ZENER DIODE	1	
	D599	B0JCND000009	DIODE	1	
	D600	B0BC7R400023	ZENER DIODE	1	
	D601	B0BC5R100039	ZENER DIODE	1	
	D602	B0BC8R100013	ZENER DIODE	1	
	D603	B0BA01900005	ZENER DIODE	1	
	D701	B0BC5R100039	ZENER DIODE	1	
△	F401	K5E802BZ0002	FUSE	1	
△	F402	K5E802BZ0002	FUSE	1	
△	F403	K5G631B00007	FUSE	1	
△	IC401	CNC1S171R	IC	1	
△	IC403	CNC1S171R	IC	1	
	IC406	C0DBZZZ00082	IC	1	
△	IC408	B3PBA0000459	IC	1	
△	IC409	MIP3E30MPSCF	IC	1	
	IC411	C0DBZMC00006	IC	1	
	IC501	C2ABDB000118	IC	1	
	IC502	C0EBH0000210	IC	1	
	IC504	C0DBZMC00006	IC	1	
△	IC505	B3PBA0000459	IC	1	
	IC506	C0DBZMC00006	IC	1	
△	IC507	B3PBA0000459	IC	1	
	IC508	C0DBZMC00006	IC	1	
	IC509	C0BBAA000093	IC	1	
	IC510	C0DBAZG00034	IC	1	
	IC511	C0DBZMC00006	IC	1	
	IC512	C0DBZMC00006	IC	1	
	IC513	C0DBZMC00006	IC	1	
	IC520	LSSK0087	IC	1	
	L403	EXCELSA35	BEAD CHOKE	1	
△	L404	G0B123K00004	CHOKE COIL	1	
△	L405	G0B123K00004	CHOKE COIL	1	
	L406	J0JCC0000004	CHIP INDUCTOR	1	
△	L410	G0B353D00002	CHOKE COIL	1	
	L511	G0C470MA0056	PEAKING COIL	1	
	L512	G0A4R7H00002	INDUCTION COIL	1	
	L514	G0A100GA0013	CHOKE COIL	1	
	L515	J0JKB0000037	FLAT CORE	1	
	L518	J0JCC0000004	CHIP INDUCTOR	1	
	P2	K1KA02A00676	2P CONNECTOR	1	
	P6	K1KA12AA0191	12P CONNECTOR	1	
	P7	K1KA11AA0191	11P CONNECTOR	1	
	P9	K1KA03A00608	3P CONNECTOR	1	
	P11	K1KA02A00676	2P CONNECTOR	1	
	P12	K1KA08A00514	8P CONNECTOR	1	
	P25	K1KA13AA0194	13P CONNECTOR	1	
	PMM1	LSGQ0234	CLAMPER	1	
	PMM2	LSGQ0235	CLAMPER	1	
	PMM3	LSGQ0235	CLAMPER	1	
	PMM5	LSGQ0235	CLAMPER	1	
	PMM6	TMME260	CLAMPER	1	
△	PR401	K5Y502BA0001	FUSE	1	
△	PR402	ERBSE0R50U	FUSE	1	
△	PR501	ERBSE0R50U	FUSE	1	
△	PR505	ERBSE5R00U	FUSE	1	

Safety	Ref. No.	Part No.	Part Name & Description	Pcs	Remarks
△	PR509	ERBSE0R50U	FUSE	1	
△	PR601	K5G312B00012	FUSE	1	
	Q401	B1CHND000004	FET	1	
	Q402	B1CBGD000001	FET	1	
	Q404	B1BCCF000022	TRANSISTOR	1	
△	Q406	B1DEKQ000004	FET	1	
	Q407	B1HFCFA00021	TRANSISTOR	1	
	Q408	B1CHND000004	FET	1	
	Q409	B1CHND000004	FET	1	
	Q411	B1HFCFA00021	TRANSISTOR	1	
△	Q412	B1DAGQ000013	FET	1	
△	Q413	B1DAGQ000013	FET	1	
	Q420	2SD1819ARL	TRANSISTOR	1	
	Q501	2SD1820A0L	TRANSISTOR	1	
	Q502	2SD1820A0L	TRANSISTOR	1	
	Q507	B1DAGQ000013	FET	1	
	Q508	2SD1819ARL	TRANSISTOR	1	
	Q509	B1HDCFA00001	TRANSISTOR	1	
	Q510	B1DFDD000019	FET	1	
	Q517	B1HBCFA00033	TRANSISTOR	1	
	Q520	B1HBCFA00033	TRANSISTOR	1	
	Q521	B1CBGD000001	FET	1	
	Q527	B1CERM000012	FET	1	
	Q530	B1ADCF000111	TRANSISTOR	1	
	Q537	B1CFQD000001	FET	1	
	Q538	2SD1819ARL	TRANSISTOR	1	
	Q540	B1DFDD000019	FET	1	
	Q541	B1CBGD000001	FET	1	
	Q553	2SD1819ARL	TRANSISTOR	1	
	Q554	B1CHND000004	FET	1	
	Q555	B1CFRD000018	FET	1	
	Q563	2SD1819ARL	TRANSISTOR	1	
	Q564	B1ADCF000111	TRANSISTOR	1	
	Q565	B1ADCF000111	TRANSISTOR	1	
	Q566	2SD1819ARL	TRANSISTOR	1	
	Q569	B1CBGD000001	FET	1	
	R401	ERJ6GEYG103	M 10KOHM, J, 1/10W	1	
	R402	ERJ6GEYG821	M 820 OHM, J, 1/10W	1	
	R403	DOGB105JA057	M 1M OHM F 1/16W	1	
	R404	ERJ6GEYG153	M 15KOHM, J, 1/10W	1	
△	R405	DOB1825JA033	M1.22MOHM, J, 0.05W	1	
	R406	ERX12SJR4R7	M 4.7 OHM, J, 1/2W	1	
	R407	D1AB2203A023	CHIP RESISTOR	1	
	R408	ERJ6GEYF472	M 4.7KOHM, F, 1/10W	1	
	R409	DOGB102JA057	M 1KOHM, J, 1/16W	1	
	R410	D1AB2203A023	CHIP RESISTOR	1	
△	R411	ERF5TJ100	W 10 OHM, J, 5W	1	
	R414	ERJ8GEYJ153	M 15KOHM, J, 1/8W	1	
	R415	D1AB2203A023	CHIP RESISTOR	1	
	R417	D1AB4303A023	CHIP RESISTOR	1	
	R418	ERJ6GEYJ6R8V	M 6.8 OHM, J, 1/10W	1	
	R419	ERJ6GEYG104	M 100KOHM, J, 1/10W	1	
	R421	ERJ3GEYJ333	M 33KOHM, J, 1/16W	1	
	R422	ERJ3GEY0R00	M 0 OHM, 1/16W	1	
	R423	ERJ6GEYG221	M 220 OHM, J, 1/10W	1	
	R424	ERJ3GEYJ223	M 22KOHM, J, 1/16W	1	
	R425	ERJ6ENF1802	M 18KOHM, 1/10W	1	
	R426	DOGB103JA057	M 10K OHM J 1/16W	1	
	R428	DOGB103JA057	M 10K OHM J 1/16W	1	
	R429	ERJ6GEYJ4R7	M 4.7 OHM, J, 1/10W	1	
	R430	D1AB4303A023	CHIP RESISTOR	1	
	R431	DOGB103JA057	M 10K OHM J 1/16W	1	

Safety	Ref. No.	Part No.	Part Name & Description	Pcs	Remarks
	R432	D1AB4303A023	CHIP RESISTOR	1	
	R433	ERJ6RBD123V	M 12KOHM, 1/10W	1	
	R436	ERJ8GEYJ153	M 15KOHM, J,1/8W	1	
	R437	D0GB183JA057	M 18K OHM J 1/16W	1	
	R438	ERJ6GEYG331	M 330 OHM,G,1/10W	1	
	R439	ERG12SJ120	M 12 OHM, J,1/2W	1	
	R440	ERJ8GEYJ474	M 470KOHM, J,1/8W	1	
	R441	D1AB6803A023	CHIP RESISTOR	1	
	R442	D1AB6803A023	CHIP RESISTOR	1	
	R443	EVMAASA00B23	CONTROL 2KOHMB	1	
	R444	ERJ6GEYF123	M 12KOHM,J,1/10W	1	
	R445	D1AB6803A023	CHIP RESISTOR	1	
	R448	DOXGR10J0003	M 0.100HM,J, 5W	1	
	R449	DOXGR10J0003	M 0.100HM,J, 5W	1	
	R450	ERJ6GEYJ4R7	M 4.7 OHM,J,1/10W	1	
	R451	ERJ3GEYJ333	M 33KOHM,J,1/16W	1	
	R452	D0GB103JA057	M 10K OHM J 1/16W	1	
	R454	D0GB103JA057	M 10K OHM J 1/16W	1	
	R455	ERJ6GEYF123	M 12KOHM,J,1/10W	1	
	R456	ERJ3GEYJ333	M 33KOHM,J,1/16W	1	
	R458	ERJ3GEYJ472	M 4.7KOHM,J,1/16W	1	
	R463	ERJ3GEYJ333	M 33KOHM,J,1/16W	1	
	R464	ERJ6ENF3302	M 33KOHM, 1/10W	1	
	R467	ERJ6GEYJ102	M 1KOHM,J,1/10W	1	
	R468	ERX12SJ1R0	M 0.1 OHM, J,1/2W	1	
	R469	ERX12SJ1R0	M 0.1 OHM, J,1/2W	1	
	R471	ERJ8GEYJ332	M 3.3KOHM, J,1/8W	1	
	R472	D1AB5603A023	CHIP RESISTOR	1	
	R473	D1AB5603A023	CHIP RESISTOR	1	
	R474	D1AB5603A023	CHIP RESISTOR	1	
	R476	ERJ14YJ181	M 180 OHM, J,1/4W	1	
	R477	ERJ14YJ181	M 180 OHM, J,1/4W	1	
	R478	ERJ8GEYJ220	M 22 OHM, J,1/8W	1	
	R482	ERJ8GEYJ220	M 22 OHM, J,1/8W	1	
△	R483	D0BF334JA030	M 330KOHM,J,0.05W	1	
	R484	ERJ6GEYF473	M 47KOHM,J,1/10W	1	
	R485	ERJ6GEYF472	M 4.7KOHM,F,1/10W	1	
	R490	ERJ6GEYG821	M 820 OHM,J,1/10W	1	
	R493	ERG12SJ120	M 12 OHM, J,1/2W	1	
	R501	ERJ6GEYJ154	M 150KOHM,J,1/10W	1	
	R502	ERJ3GEYJ224	M 220KOHM,J,1/16W	1	
	R503	ERJ3GEYJ224	M 220KOHM,J,1/16W	1	
	R505	ERJ8GEYJ330	M 33 OHM, J,1/8W	1	
	R507	ERJ6GEYG221	M 220 OHM,J,1/10W	1	
	R508	D0GB182JA057	M 1.8KOHM J 1/16W	1	
	R510	ERJ8GEYJ120	M 12 OHM, J,1/8W	1	
	R512	ERJ3GEYJ823	M 82KOHM,J,1/16W	1	
	R513	ERJ3GEYJ332	M 3.3KOHM,J,1/16W	1	
	R514	ERJ3GEYJ104	M 100KOHM,J,1/16W	1	
	R518	D0GB102JA057	M 1KOHM,J,1/16W	1	
	R519	ERJ3GEYJ104	M 100KOHM,J,1/16W	1	
	R520	ERJ6GEYJ101V	M 100 OHM,J,1/10W	1	
	R521	ERJ6GEYJ104	M 100KOHM,J,1/10W	1	

Safety	Ref. No.	Part No.	Part Name & Description	Pcs	Remarks
	R523	ERJ6GEYF473	M 47KOHM,J,1/10W	1	
	R524	D0GB102JA057	M 1KOHM,J,1/16W	1	
	R526	ERJ6ENF1803	M 180KOHM, 1/10W	1	
	R527	ERJ6ENF1803	M 180KOHM, 1/10W	1	
	R528	ERJ6GEYJ4R7	M 4.7 OHM,J,1/10W	1	
	R529	ERJ6GEYJ101V	M 100 OHM,J,1/10W	1	
	R530	ERJ3RBD333	M 33KOHM, 1/16W	1	
	R531	ERJ3RBD333	M 33KOHM, 1/16W	1	
	R532	ERJ6GEYJ102	M 1KOHM,J,1/10W	1	
	R533	ERJ6ENF1693	M 169KOHM, 1/10W	1	
	R534	ERJ3EKF8201	M 8.2KOHM, 1/16W	1	
	R535	D0GB105JA057	M 1M OHM F 1/16W	1	
	R536	ERJ3GEY0R00	M 0 OHM, 1/16W	1	
	R537	ERJ6ENF1003	M 100KOHM, 1/10W	1	
	R539	D0GB103JA057	M 10K OHM J 1/16W	1	
	R540	D0GB105JA057	M 1M OHM F 1/16W	1	
	R542	ERJ6GEYJ223	M 22KOHM,J,1/10W	1	
	R543	D0GB393JA041	M 39KOHM,J,1/16W	1	
	R544	ERJ6ENF1502	M 15KOHM, 1/10W	1	
	R546	ERJ3GEYJ104	M 100KOHM,J,1/16W	1	
	R547	ERJ3GEYJ101	M 100 OHM,J,1/16W	1	
	R549	ERJ6GEYJ104	M 100KOHM,J,1/10W	1	
	R551	D0GB151JA057	M 150 OHM J 1/16W	1	
	R552	ERJ3GEYJ104	M 100KOHM,J,1/16W	1	
	R555	ERJ3GEYJ224	M 220KOHM,J,1/16W	1	
	R556	ERJ6GEYJ105	M 1MOHM,J,1/10W	1	
	R557	ERJ6GEYJ101V	M 100 OHM,J,1/10W	1	
	R558	ERJ3GEYJ101	M 100 OHM,J,1/16W	1	
	R559	ERJ3EKF8201	M 8.2KOHM, 1/16W	1	
	R560	ERJ6ENF9101	M 9.1KOHM, 1/10W	1	
	R561	ERJ6ENF5101	M 5.1KOHM, 1/10W	1	
	R562	ERJ3EKF4701	M 4.7KOHM, 1/16W	1	
	R563	ERJ6GEYJ2R2	M 2.2 OHM,J,1/10W	1	
	R565	ERJ6GEY0R00V	M 0 OHM J 1/10W	1	
	R567	ERJ8GEYJ105	M 1MOHM, J,1/8W	1	
	R568	ERJ8GEYJ105	M 1MOHM, J,1/8W	1	
	R569	ERJ3EKF3302	M 33KOHM, 1/16W	1	
	R570	ERJ3GEY0R00	M 0 OHM, 1/16W	1	
	R571	ERJ6GEYJ105	M 1MOHM,J,1/10W	1	
	R572	ERJ3GEYJ104	M 100KOHM,J,1/16W	1	
	R573	D0GB102JA057	M 1KOHM,J,1/16W	1	
	R574	ERJ3GEYJ331	M 330 OHM,J,1/16W	1	
	R575	ERJ3GEYJ224	M 220KOHM,J,1/16W	1	
	R576	ERJ6RBD123V	M 12KOHM, 1/10W	1	
	R577	ERJ6GEYJ102	M 1KOHM,J,1/10W	1	
	R579	D0GB103JA057	M 10K OHM J 1/16W	1	
	R580	ERJ3GEYJ223	M 22KOHM,J,1/16W	1	
	R581	ERJ6GEYF473	M 47KOHM,J,1/10W	1	
	R582	ERJ6ENF1002	M 10KOHM, 1/10W	1	
	R583	ERJ3GEY0R00	M 0 OHM, 1/16W	1	
	R584	ERJ6GEYJ103	M 10KOHM,J,1/10W	1	
	R585	ERJ3GEYJ333	M 33KOHM,J,1/16W	1	
	R586	ERJ6GEYJ223	M 22KOHM,J,1/10W	1	
	R587	ERJ8RSJR16V	M 16 OHM, 1/8W	1	
	R592	ERJ3GEYJ223	M 22KOHM,J,1/16W	1	
	R593	ERJ3GEYJ104	M 100KOHM,J,1/16W	1	
	R594	D0GB151JA057	M 150 OHM J 1/16W	1	
	R595	ERJ6GEYJ221	M 220 OHM,J,1/10W	1	

Safety	Ref. No.	Part No.	Part Name & Description	Pcs	Remarks
	R596	ERJ6GEYJ101V	M 100 OHM,J,1/10W	1	
	R597	ERJ3EKF3302	M 33KOHM, 1/16W	1	
	R598	ERJ3EKF3302	M 33KOHM, 1/16W	1	
	R599	ERJ8ENF3900	M 390 OHM, 1/8W	1	
	R600	ERJ8ENF3900	M 390 OHM, 1/8W	1	
	R601	ERJ3GEYJ471	M 470 OHM,J,1/16W	1	
	R603	ERJ6GEYJ101V	M 100 OHM,J,1/10W	1	
	R604	ERJ3EKF3002	M 30KOHM, 1/16W	1	
	R605	DOGB103JA057	M 10K OHM J 1/16W	1	
	R606	ERJ6ENF1201	M 1.2KOHM, 1/10W	1	
	R607	ERJ3EKF1602	M16.0KOHM, 1/16W	1	
	R608	ERJ8GEYJ332	M 3.3KOHM, J,1/8W	1	
	R609	DOGB103JA057	M 10K OHM J 1/16W	1	
	R610	ERJ6GEYG222	M 2.2KOHM,J,1/10W	1	
	R611	ERDS2FJ101	C 100 OHM, J,1/4W	1	
	R612	ERJ6GEYG222	M 2.2KOHM,J,1/10W	1	
	R613	ERJ3EKF2402	M 24KOHM, 1/16W	1	
	R614	ERJ3EKF3301	M 3.3KOHM, 1/16W	1	
	R616	ERJ6GEYJ223	M 22KOHM,J,1/10W	1	
	R617	ERJ3GEYJ223	M 22KOHM,J,1/16W	1	
	R618	ERJ3GEYJ104	M 100KOHM,J,1/16W	1	
	R619	ERJ8RQFR39	M 0.39OHM, J,1/8W	1	
	R620	DOGB102JA057	M 1KOHM,J,1/16W	1	
	R622	ERJ6ENF1603	M 160KOHM, 1/10W	1	
	R624	ERX2SJR22P	M0.22 OHM, J, 2W	1	
	R626	ERJ6ENF1503	M 150KOHM, 1/10W	1	
	R627	ERJ3EKF7501	M 7.5KOHM, 1/16W	1	
	R628	D3CA72020013	M2.0 KOHM,J,0.5W	1	
	R629	ERJ6GEYJ684	M 680KOHM,J,1/10W	1	
	R631	ERJ8GEYJ333	M 33KOHM, J,1/8W	1	
	R632	ERJ6GEYG221	M 220 OHM,J,1/10W	1	
	R634	ERJ8RQFR39	M 0.39OHM, J,1/8W	1	
	R635	ERJ6GEYG103	M 10KOHM,J,1/10W	1	
	R636	ERJ6ENF1603	M 160KOHM, 1/10W	1	
	R637	ERJ8RQFR39	M 0.39OHM, J,1/8W	1	
	R639	ERJ8RQFR39	M 0.39OHM, J,1/8W	1	
	R640	ERJ8RQFR39	M 0.39OHM, J,1/8W	1	
	R641	ERJ6GEYF473	M 47KOHM,J,1/10W	1	
	R642	ERJ8RQFR39	M 0.39OHM, J,1/8W	1	
	R643	ERJ8RQFR39	M 0.39OHM, J,1/8W	1	
	R644	ERJ8RQFR39	M 0.39OHM, J,1/8W	1	
	R645	ERJ6GEYJ101V	M 100 OHM,J,1/10W	1	
	R646	ERJ14YJ330	M 33 OHM, J,1/4W	1	
	R647	ERJ14YJ330	M 33 OHM, J,1/4W	1	
	R648	ERJ6ENF1603	M 160KOHM, 1/10W	1	
	R651	ERJ3EKF1002	M 10KOHM, 1/16W	1	
	R652	ERJ3RBD163	M 16KOHM, 1/16W	1	
	R653	ERJ3EKF3302	M 33KOHM, 1/16W	1	
	R654	ERJ8ENF1801	M1.80KOHM, 1/8W	1	
	R655	ERJ8RSJR16V	M 16 OHM, 1/8W	1	
	R656	ERJ6ENF1803	M 180KOHM, 1/10W	1	
	R657	ERJ3GEYJ561	M 560 OHM,J,1/16W	1	
	R659	ERJ3EKF3002	M 30KOHM, 1/16W	1	
	R660	ERJ3EKF1202	M 12KOHM, 1/16W	1	
	R661	EVMAASA00B53	CONTROL 5KOHMB	1	

Safety	Ref. No.	Part No.	Part Name & Description	Pcs	Remarks
	R662	ERJ6ENF1503	M 150KOHM, 1/10W	1	
	R664	ERJ3EKF9101	M 9.1KOHM, 1/16W	1	
	R665	EVMAASA00B23	CONTROL 2KOHMB	1	
	R666	ERJ8ENF1801	M1.80KOHM, 1/8W	1	
	R669	ERJ6ENF1503	M 150KOHM, 1/10W	1	
	R670	DOGB102JA057	M 1KOHM,J,1/16W	1	
	R671	ERJ3RBD112	M 1.1KOHM,1/16W	1	
	R672	ERJ6GEYJ102	M 1KOHM,J,1/10W	1	
	R673	ERJ6GEYJ102	M 1KOHM,J,1/10W	1	
	R674	ERJ8GEYJ333	M 33KOHM, J,1/8W	1	
	R675	ERJ3EKF2202	M 22KOHM, 1/16W	1	
	R676	ERJ8GEYJ333	M 33KOHM, J,1/8W	1	
	R677	ERJ3GEYJ474	M 470KOHM,J,1/16W	1	
	R678	ERJ8RSJR16V	M 16 OHM, 1/8W	1	
	R679	ERJ8RSJR16V	M 16 OHM, 1/8W	1	
	R680	ERJ8RSJR16V	M 16 OHM, 1/8W	1	
	R682	ERJ6ENF2002	M 20KOHM, 1/10W	1	
	R683	ERJ14YJ330	M 33 OHM, J,1/4W	1	
	R684	DOGB102JA057	M 1KOHM,J,1/16W	1	
	R686	DOGB123JA057	M 12K OHM J 1/16W	1	
	R687	ERJ3GEYJ104	M 100KOHM,J,1/16W	1	
	R688	DOGB102JA057	M 1KOHM,J,1/16W	1	
	R689	ERJ8GEYJ472	M 4.7KOHM, J,1/8W	1	
	R690	ERJ6GEYJ4R7	M 4.7 OHM,J,1/10W	1	
	R691	ERJ3GEYJ564	M 560KOHM,J,1/16W	1	
	R693	ERJ6GEYJ4R7	M 4.7 OHM,J,1/10W	1	
	R695	ERJ3EKF1602	M16.0KOHM, 1/16W	1	
	R696	ERJ6GEYJ4R7	M 4.7 OHM,J,1/10W	1	
	R697	ERJ6GEYJ4R7	M 4.7 OHM,J,1/10W	1	
	R698	ERJ8RSJR16V	M 16 OHM, 1/8W	1	
	R699	ERJ8GEYJ105	M 1MOHM, J,1/8W	1	
	R700	ERJ6ENF1503	M 150KOHM, 1/10W	1	
	R701	ERJ6ENF1503	M 150KOHM, 1/10W	1	
	R702	ERJ3EKF1102	M 11KOHM, 1/16W	1	
	R707	DOGB102JA057	M 1KOHM,J,1/16W	1	
	R708	DOGB102JA057	M 1KOHM,J,1/16W	1	
	R709	ERJ3GEYJ101	M 100 OHM,J,1/16W	1	
	R710	ERJ6GEYJ101V	M 100 OHM,J,1/10W	1	
	R711	ERJ6GEYG222	M 2.2KOHM,J,1/10W	1	
	R712	ERJ6GEYG222	M 2.2KOHM,J,1/10W	1	
	R713	ERJ6GEYJ152	M 1.5KOHM,J,1/10W	1	
	R714	ERJ6GEYJ102	M 1KOHM,J,1/10W	1	
	R715	ERJ6ENF3301	M 3.3KOHM, 1/10W	1	
	R716	ERJ6GEYOR00V	M 0 OHM J 1/10W	1	
	R717	ERJ6GEYJ122	M 1.2KOHM,J,1/10W	1	
	R719	ERJ6GEYJ102	M 1KOHM,J,1/10W	1	
	R720	DOGB152JA057	M 1.5KOHM J 1/16W	1	
	R721	ERJ6GEYOR00V	M 0 OHM J 1/10W	1	
	R722	ERJ6GEYJ102	M 1KOHM,J,1/10W	1	
	R723	DOGB102JA057	M 1KOHM,J,1/16W	1	
	R724	DOGB102JA057	M 1KOHM,J,1/16W	1	
	R725	ERJ3GEYJ823	M 82KOHM,J,1/16W	1	
	R726	ERJ6GEYF472	M 4.7KOHM,F,1/10W	1	
	R727	ERJ6GEYJ332	M 3.3KOHM,J,1/10W	1	
	R730	ERJ8GEYJ105	M 1MOHM, J,1/8W	1	
	R731	ERJ8GEYJ105	M 1MOHM, J,1/8W	1	
	R732	ERJ8GEYJ105	M 1MOHM, J,1/8W	1	
	R733	ERJ8GEYJ105	M 1MOHM, J,1/8W	1	



Safety	Ref. No.	Part No.	Part Name & Description	Pcs	Remarks
	R734	ERJ8GEYJ105	M 1MOHM, J,1/8W	1	
	R735	ERJ8GEYJ105	M 1MOHM, J,1/8W	1	
	R736	ERJ8GEYJ105	M 1MOHM, J,1/8W	1	
	R737	ERJ8GEYJ105	M 1MOHM, J,1/8W	1	
	R738	ERJ8GEYJ105	M 1MOHM, J,1/8W	1	
	R739	ERJ3EKF1803	M 180KOHM, 1/16W	1	
	R742	DOGB102JA057	M 1KOHM,J,1/16W	1	
△	RL401	K6B1CGA00055	REALY	1	
△	RL402	K6B1CGA00055	REALY	1	
△	RL403	K6B1CGA00055	REALY	1	
△	S401	JOLT00000009	SWITCH	1	
△	S402	JOLT00000009	SWITCH	1	
	T401	G4D4A0000123	SWITCHING TRANS	1	
△	T402	G4D1A0000132	SWITCHING TRANS	1	
△	T404	ETS42LB11GAD	SWITCHING TRANS	1	
△	T410	G4D1A0000133	SWITCHING TRANS	1	
	T601	G4D2A0000295	SWITCHING TRANS	1	
	X501	H2B400400021	CRYSTAL	1	
	Z1	K4ZZ01000206	TERMINAL	1	
	Z2	K4ZZ01000206	TERMINAL	1	
	Z3	K4ZZ01000206	TERMINAL	1	
△	ZN401	ERZVRED621	VARISTOR	1	
△	ZN402	ERZVRED621	VARISTOR	1	
△	ZN403	ERZVGAD681T2	VARISTOR	1	
△	ZN404	ERZVA7D511	VARISTOR	1	
△	ZN405	ERZVA7D511	VARISTOR	1	