

Service Manual

DVD/CD Player

Model No. **DVD-S500EB**

DVD-S500EG

DVD-S500EP

DVD-S700EP



DVD-S700



Colour

(K).....Black Type

WARNING

This service information is designed for experienced repair technicians only and is not designed for use by the general public. It does not contain warnings or cautions to advise non-technical individuals of potential dangers in attempting to service a product. Products powered by electricity should be serviced or repaired only by experienced professional technicians. Any attempt to service or repair the product or products dealt with in this service information by anyone else could result in serious injury or death.

Panasonic®

© Panasonic Corporation 2013
Unauthorized copying and distribution is a violation of law.

TABLE OF CONTENTS

	PAGE
1 Safety Precautions	3
1.1. General Guidelines	3
1.2. Leakage Current Cold Check	3
1.3. Leakage Current Hot Check (See Figure 1.).....	3
2 Warning	4
2.1. Prevention of Electrostatic Discharge (ESD) to Electrostatically Sensitive (ES) Devices	4
2.2. Caution for AC Cord (For the United Kingdom and Republic of Ireland).....	5
2.3. Precaution of Laser Diode	6
2.4. Static Electricity Protection Measures	7
2.5. Ground for Electrostatic Breakdown Prevention	7
3 Service Navigation	8
3.1. Service Information	8
3.2. How to Check Recognition of USB Device	8
3.3. How to Update Firmware.....	9
4 Specifications	10
4.1. Others (Licenses)	11
5 Location of Controls and Components	12
6 Operating Instruction	13
6.1. Take out the Disc from Drive Unit when the Disc cannot be ejected by the OPEN/CLOSE button	13
7 Troubleshooting Guide	14
7.1. About Operation of Set	14
7.2. About Circuit	15
8 Wiring Connection and Voltage Data	17
8.1. DVD-S500	17
8.2. DVD-S700	18
9 Disassembly and Assembly Instructions	19
9.1. Unit (DVD-S500/S700)	19
10 Exploded View and Replacement Parts List	22
10.1. Casing Parts & Mechanism Section	22
10.2. Packing & Accessories Section	23
10.3. Replacement Parts List	24

1 Safety Precautions

1.1. General Guidelines

1. IMPORTANT SAFETY NOTICE

There are special components used in this equipment which are important for safety. These parts are marked by Δ in the Schematic Diagrams, Circuit Board Layout, Exploded Views and Replacement Parts List. It is essential that these critical parts should be replaced with manufacturer's specified parts to prevent X-RADIATION, shock, fire, or other hazards. Do not modify the original design without permission of manufacturer.

2. An Isolation Transformer should always be used during the servicing of AC Adaptor whose chassis is not isolated from the AC power line. Use a transformer of adequate power rating as this protects the technician from accidents resulting in personal injury from electrical shocks. It will also protect AC Adaptor from being damaged by accidental shorting that may occur during servicing.
3. When servicing, observe the original lead dress. If a short circuit is found, replace all parts which have been overheated or damaged by the short circuit.
4. After servicing, see to it that all the protective devices such as insulation barriers, insulation papers shields are properly installed.
5. After servicing, make the following leakage current checks to prevent the customer from being exposed to shock hazards.

1.2. Leakage Current Cold Check

1. Unplug the AC cord and connect a jumper between the two prongs on the plug.
2. Measure the resistance value, with an ohmmeter, between the jumpered AC plug and each exposed metallic cabinet part on the equipment such as screwheads, connectors, control shafts, etc. When the exposed metallic part has a return path to the chassis, the reading should be between $1M\Omega$ and $5.2M\Omega$. When the exposed metal does not have a return path to the chassis, the reading must be infinity.

1.3. Leakage Current Hot Check (See Figure 1.)

1. Plug the AC cord directly into the AC outlet. Do not use an isolation transformer for this check.
2. Connect a $1.5k\Omega$, 10W resistor, in parallel with a $0.15\mu F$ capacitor, between each exposed metallic part on the set and a good earth ground, as shown in Figure 1.
3. Use an AC voltmeter, with $1k\Omega/V$ or more sensitivity, to measure the potential across the resistor.
4. Check each exposed metallic part, and measure the voltage at each point.
5. Reverse the AC plug in the AC outlet and repeat each of the above measurements.
6. The potential at any point should not exceed 0.75V RMS. A leakage current tester (Simpson Model 229 or equivalent) may be used to make the hot checks, leakage current must not exceed $1/2$ mA. In case a measurement is outside of the limits specified, there is a possibility of a shock hazard, and the equipment should be repaired and rechecked before it is returned to the customer.

Hot-Check Circuit

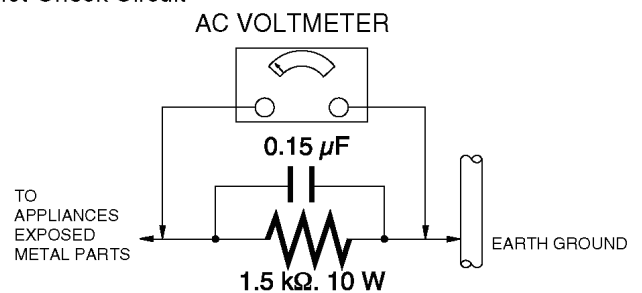

Figure. 1

2 Warning

2.1. Prevention of Electrostatic Discharge (ESD) to Electrostatically Sensitive (ES) Devices

Some semiconductor (solid state) devices can be damaged easily by static electricity. Such components commonly are called Electrostatically Sensitive (ES) Devices.

Examples of typical ES devices are IC(integrated circuits)and some field-effect transistors and semiconductor "chip" components.

The following techniques should be used to help reduce the incidence of component damage caused by electrostatic discharge(ESD).

1. Immediately before handling any semiconductor component or semiconductor-equipped assembly, drain off any ESD on your body by touching a known earth ground. Alternatively, obtain and wear a commercially available discharging ESD wrist strap, which should be removed for potential shock reasons prior to applying power to the unit under test.
2. After removing an electrical assembly equipped with ES devices, place the assembly on a conductive surface such as aluminum foil, to prevent electrostatic charge buildup or exposure of the assembly.
3. Use only a grounded-tip soldering iron to solder or unsolder ES devices.
4. Use only an antistatic solder removal device. Some solder removal devices not classified as "antistatic (ESD protected)" can generate electrical charge sufficient to damage ES devices.
5. Do not use freon-propelled chemicals. These can generate electrical charges sufficient to damage ES devices.
6. Do not remove a replacement ES device from its protective package until immediately before you are ready to install it. (Most replacement ES devices are packaged with leads electrically shorted together by conductive foam, aluminum foil or comparable conductive material).
7. Immediately before removing the protective material from the leads of a replacement ES device, touch the protective material to the chassis or circuit assembly into which the device will be installed.

CAUTION :

Be sure no power is applied to the chassis or circuit, and observe all other safety precautions.

8. Minimize bodily motions when handling unpackaged replacement ES devices. (Otherwise harmless motion such as the brushing together of your clothes fabric or the lifting of your foot from a carpeted floor can generate static electricity (ESD) sufficient to damage an ES device).

IMPORTANT SAFETY NOTICE

There are special components used in this equipment which are important for safety. These parts are marked by Δ in the Schematic Diagrams, Circuit Board Diagrams, Exploded View and Replacement Parts List, It is essential that these critical parts should be replaced with manufacturer's specified, parts to prevent shock, fire or other hazards, Do not modify the original design without permission of manufacturer.

2.2. Caution for AC Cord (For the United Kingdom and Republic of Ireland)

2.2.1. Information for Your Safety

IMPORTANT

Your attention is drawn to the fact that recording of prerecorded tapes or discs or other published or broadcast material may infringe copyright laws.

WARNING

To reduce the risk of fire or shock hazard, do not expose this equipment to rain or moisture.

CAUTION

To reduce the risk of fire or shock hazard and annoying interference, use the recommended accessories only.

FOR YOUR SAFETY

DO NOT REMOVE THE OUTER COVER

To prevent electric shock, do not remove the cover. No user serviceable parts inside. Refer servicing to qualified service personnel.

2.2.2. Caution for AC Mains Lead

For your safety, please read the following text carefully.

This appliance is supplied with a moulded three-pin mains plug for your safety and convenience.

A 5-ampere fuse is fitted in this plug.

Should the fuse need to be replaced please ensure that the replacement fuse has a rating of 5 amperes and it is approved by ASTA or BSI to BS1362

Check for the ASTA mark or the BSI mark on the body of the fuse.



If the plug contains a removable fuse cover you must ensure that it is refitted after the fuse is replaced.

If you lose the fuse cover, the plug must not be used until a replacement cover is obtained.

A replacement fuse cover can be purchased from your local Panasonic Dealer.

If the fitted moulded plug is unsuitable for the socket outlet in your home then the fuse should be removed and the plug cut off and disposed of safely.

There is a danger of severe electrical shock if the cut off plug is inserted into any 13-ampere socket.

If a new plug is to be fitted please observe the wiring code as shown below.

If in any doubt, please consult a qualified electrician.

2.2.2.1. Important

The wires in this mains lead are coloured in accordance with the following code:

Blue	Neutral
Brown	Live

As the colours of the wires in the mains lead of this appliance may not correspond with the coloured markings identifying the terminals in your plug, proceed as follows:

The wire which is coloured BLUE must be connected to the terminal in the plug which is marked with the letter N or coloured BLACK.

The wire which is coloured BROWN must be connected to the terminal in the plug which is marked with the letter L or coloured RED.

Under no circumstances should either of these wires be connected to the earth terminal of the three pin plug, marked with the letter E or the Earth Symbol.

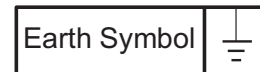

2.2.2.2. Before Use

Remove the Connector Cover as follows.

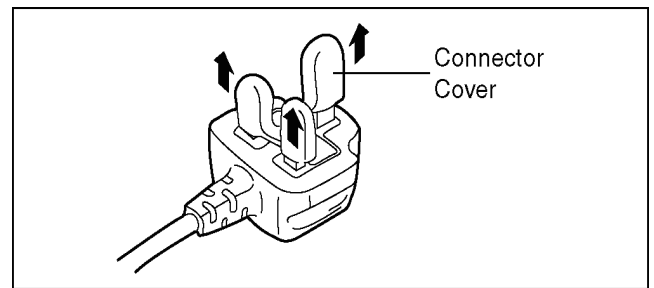

2.2.2.3. How to Replace the Fuse

1. Remove the Fuse Cover with a screwdriver.

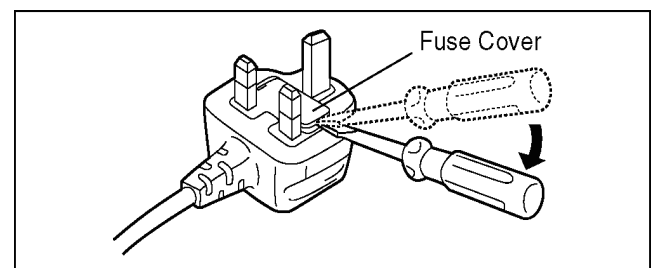

2. Replace the Fuse and attach the Fuse cover.

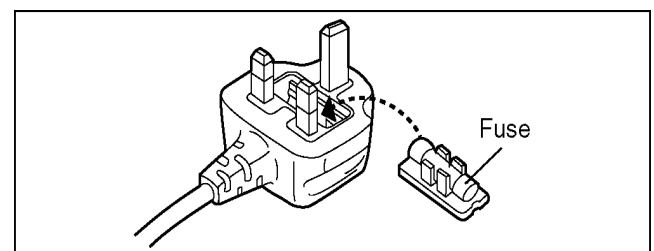

2.3. Precaution of Laser Diode

CAUTION :

This product utilizes a laser diode with the unit turned "on", invisible laser radiation is emitted from the pick-up lens. Wave length:770 to 800 nm (CDs)/645 to 660 nm (DVDs) Maximum output radiation power from pick-up:100 μ W/VDE Laser radiation from the pick-up lens is safety level, but be sure the followings:

1. Do not disassemble the optical pick-up unit, since radiation from exposed laser diode is dangerous.
2. Do not adjust the variable resistor on the pick-up unit, it was already adjusted.
3. Do not look at the focus lens using optical instruments.
4. Recommend not to look at pick-up lens for a long time.

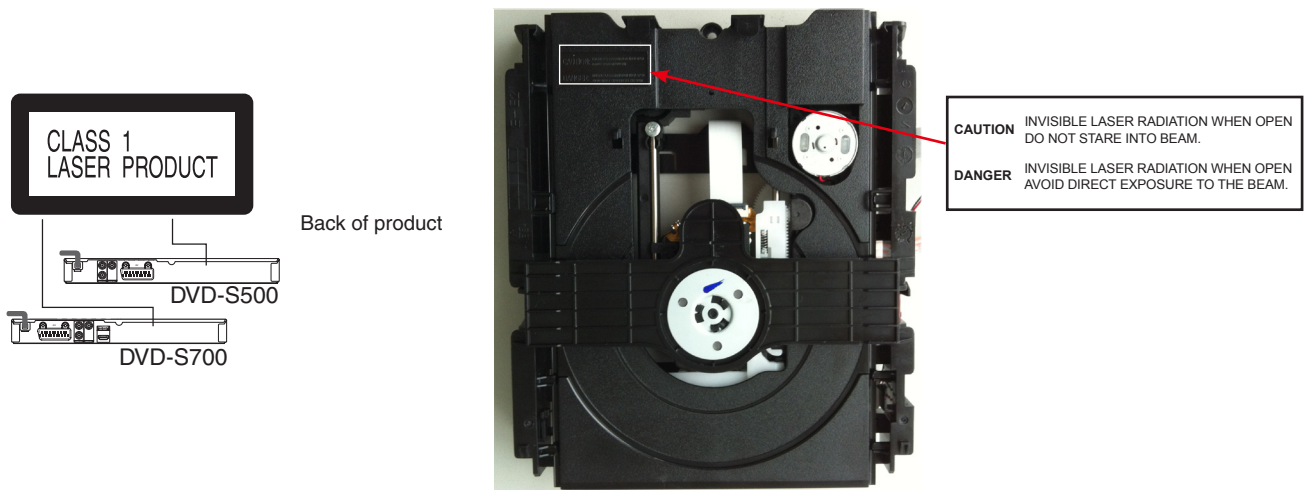

CAUTION !

THIS PRODUCT UTILIZES A LASER.

USE OF CONTROLS OR ADJUSTMENTS OR PERFORMANCE OF PROCEDURES OTHER THAN THOSE SPECIFIED HEREIN MAY RESULT IN HAZARDOUS RADIATION EXPOSURE.

2.4. Static Electricity Protection Measures

- The laser diode in the traverse unit (optical pick-up) may break down due to potential difference caused by static electricity of clothes or human body.
So, be careful of electrostatic breakdown during repair of the traverse unit (optical pick-up).

2.5. Ground for Electrostatic Breakdown Prevention

- As for parts that use optical pick-up (laser diode), the optical pick-up is destroyed by the static electricity of the working environment.
Repair in the working environment that is grounded.

2.5.1. Work table grounding

- Put a conductive material (sheet) or steel sheet on the area where the traverse unit (optical pick-up) is placed, and ground the sheet.

2.5.2. Human body grounding

- Use the anti-static wrist strap to discharge the static electricity from your body.

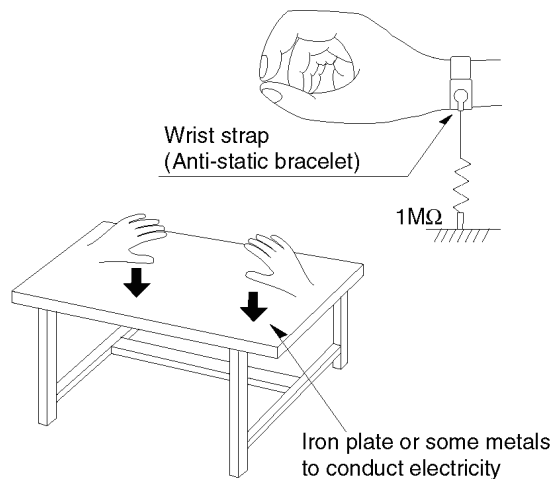

2.5.3. When exchanging the Drive

- Before remove the ESD prevention bag, make sure to use the anti-static wrist strap to discharge the static electricity when replace the Drive.

Note:

The ESD prevention bag is used to replace the original short-circuit point.
It can be removed while placing the Drive.

3 Service Navigation

3.1. Service Information

This service manual contains technical information, which allow service personnels to understand and service this model. Please place orders using the parts list and not the drawing reference numbers. If the circuit is changed or modified, the information will be followed by service manual to be controlled with original service manual.

Note:

The replacement parts of this model is supplied as block unit.
Please use Troubleshooting Guide for your reference of the repair.

3.2. How to Check Recognition of USB Device

3.2.1. USB Device Check Flow Chart

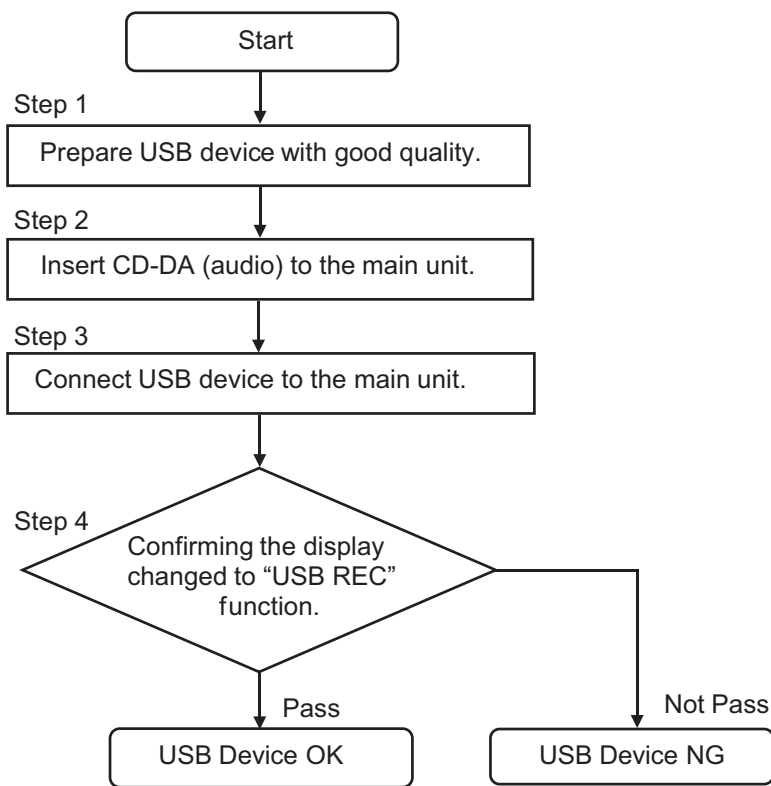

Step 2 (Example)

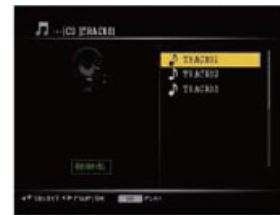

Step 3 (Example)



Step 4 (Example)



3.3. How to Update Firmware

The firmware of the DVD player may be renewed to improve the quality including operational performance and playability. Make sure to refer the following procedure when performing version-up.

Step1 Check the software version currently installed in your DVD player.

1. Open the disc tray.
2. Press the [6] button on the remote control four times, then Software version will appear.



(DVD-S700)

NOTE: Software version displays for about ten seconds.
Please make a note of the version number.

Step 2 Download the latest software.

The latest firmware required for version-up can be downloaded from “Support Information from NWBG/VDBG-PAVC” web-site in “TSN system”.

Click file name to download.

After download, click file to decompress.(Total:1file)

Step 3 Decompress the downloaded file.

Use only CD-R.

1. The decompressed file will be named as below.(Confirm the model No.)
File Name: PANASONICXX.BIN
2. Burn all files to a blank CD-R disc by the writing software.
(Burning method to CD-R disc is not image data writing but normal data writing.)

Step 4 Playback the CD-R disc by DVD Player



Set the CD-R disc into the DVD player and playback it.



When the message of recommending the “Software Update” appears on the display monitor, select [Left cursor button: Yes] or [Right cursor button: No] and press the [OK] button with the remote control.

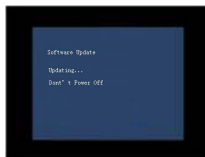

If you choose [Left cursor button: Yes], the DVD player is automatically updated.

Step 5 Software update is completed.

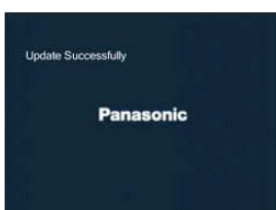

4 Specifications

Power supply: AC 220 to 240 V, 50 Hz
Power consumption: Approx. 10 W
Power consumption in standby mode: Less than 1W
Dimensions: 310(W) x 210(D) x 39(H) mm
Mass: Approx. 1.1 kg
Signal system: PAL/NTSC
Operating temperature range: + 5 to + 35°C
Operating humidity range: 20 to 80 % RH (no condensation)

Playable medias:

- (1) DVD Video (DVD-Video format)
- (2) DVD-RW (DVD-Video format*¹)
- (3) DVD-R DL JPEG*^{2*3}, MP3*⁴, Xvid*^{5*6*7}
- (4) +RW / +R / +R DL (Video*¹)
- (5) Audio CD (CD-DA)
- (6) Video CD
- (7) Super Video CD
- (8) CD-R / CD-RW (CD-DA, JPEG*^{2*3}, MP3*⁴, Xvid*^{5*6*7}, Video CD, Super Video CD)
- (9) USB (MP3*⁴, JPEG*^{2*3}, Xvid*^{5*6*7})

*1 Finalizing is necessary.

*2 The file extensions has to be '.JPG' or '.JPEG'.

*3 Files that have been altered, edited or saved with computer picture editing software may not be displayed.

*4 The file extension has to be '.mp3'.

*5 The file extension has to be '.XVID', '.xvid', '.AVI', or '.avi'.

*6 (South Africa) Subtitle text file is supported.
(For others) Subtitle text file is not supported.

*7 Certified to the Xvid Home Profile.

NOTE

- It may not be possible to play the medias in some cases due to the type of media, the condition of the recording, the recording method and how the files were created.

(For USB devices)

- This unit does not guarantee connection with all USB devices.
- This unit does not support USB device charging.
- FAT12, FAT16 and FAT32 file systems are supported.
- This unit supports USB2.0 High Speed.
- This unit can support an HDD formatted to FAT32. Some types of HDD may require the use of its external power supply unit.

Video output:
Output level: 1.0 Vp-p (75 Ω)
Output connector: Pin jack (1 system)

**HDMI AV Output:
(DVD-S700 only)**
Output format: 1080p/1080i/720p/576p/480p
Output connector: TypeA (19 pin)
This unit supports "HDMI CEC" function.

Video performance:
Horizontal resolution: More than 500 lines
Video S/N ratio: More than 53 dB

Audio output:
Output level: 2 Vrms (1 kHz, 0 dB)
Output connector: Pin jack
Number of connectors: [DVD-S500, S700]
2 channel (1 system)
USB slot: USB 2.0: 1 system

Digital audio output: coaxial digital output Pin jack (1 system)

Audio performance:
(1) Frequency response:
DVD (linear audio): 4 Hz-22 kHz (48 kHz sampling)
CD audio: 4 Hz-20 kHz
(2) S / N ratio:
CD audio: 90dB
(3) Dynamic range:
CD audio: 80dB
(4) Total harmonic distortion:
CD audio: 0.04%

Pickup:
Wave length: 770 to 800 nm (CD) /
645 to 660 nm (DVD)
Laser power: CLASS I / CLASS I

Note:

Specifications are subject to change without notice.
Mass and dimensions are approximate.

Solder:

This unit uses lead free solder (PbF).

4.1. Others (Licenses)

“DVD Logo” is a trademark of DVD Format/Logo Licensing Corporation.

Manufactured under license from Dolby Laboratories. Dolby and the double-D symbol are trademarks of Dolby Laboratories.

HDMI, the HDMI Logo, and High-Definition Multimedia Interface are trademarks or registered trademarks of HDMI Licensing LLC in the United States and other countries.

This item incorporates copy protection technology that is protected by U.S. patents and other intellectual property rights of Rovi Corporation. Reverse engineering and disassembly are prohibited.

MPEG Layer-3 audio coding technology licensed from Fraunhofer IIS and Thomson.

The recording and playback of content on this or any other device may require permission from the owner of the copyright or other such rights in that content. Panasonic has no authority to and does not grant you that permission and explicitly disclaims any right, ability or intention to obtain such permission on your behalf. It is your responsibility to ensure that your use of this or any other device complies with applicable copyright legislation in your country. Please refer to that legislation for more information on the relevant laws and regulations involved or contact the owner of the rights in the content you wish to record or playback.

5 Location of Controls and Components

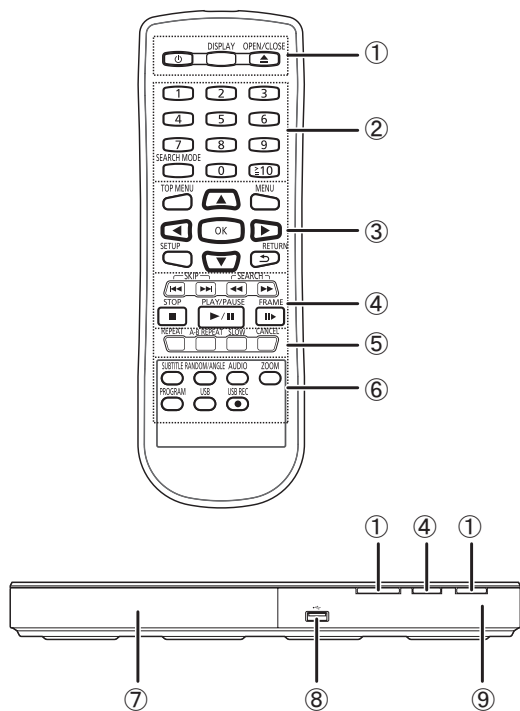

① Standby/on switch ϕ , $\phi/1$

Press to switch the unit from on to standby mode or vice versa. In standby mode, the unit is still consuming a small amount of power.

DISPLAY

Displays information on TV screen during playback.

OPEN/CLOSE \blacktriangle

Opens/closes the disc tray.

② 0-9, ≥ 10

To select title/chapter/track numbers etc.

e.g., 5: 5

15: $\geq 10 \rightarrow 1 \rightarrow 5$

SEARCH MODE

Starts to select the point

1. Press \blacktriangle \blacktriangledown \blacktriangleleft \blacktriangleright to select the item.
2. Press 0 to 9 to specify the location.
3. Press OK.

③ TOP MENU

Shows Top menu

MENU

- Shows Menu
- Sets PBC of VCD equipped with Playback Control (PBC) function to On/Off

\blacktriangle \blacktriangledown \blacktriangleleft \blacktriangleright

- Selects items, input position, etc.
 - For moving the display position of enlarged images
 - For rotating JPEG images

OK

Confirms menu selection

SETUP

Enters or exits the system setup menu

RETURN \curvearrowright

Returns to the previous display

④ SKIP, \blacktriangleleft \blacktriangleright

- Skips to previous title/chapter/track or next title/chapter/track
- Switches the MENU page of VCD equipped with Playback Control (PBC) function

SEARCH, \blacktriangleleft \blacktriangleright

Starts fast reverse or fast forward

STOP \blacksquare , \blacksquare

Stops playback

PLAY/PAUSE \blacktriangle \blacksquare , \blacktriangleright \blacksquare

Starts or pauses playback

FRAME \blacksquare \blacktriangleright

Plays Video frame by frame

⑤ REPEAT

Selects various repeat mode

Selectable modes differ depending on the type of contents. REP DIR plays all the same type of files in the selected folder repeatedly.

A-B REPEAT

Repeats playback from point A to B on a media

SLOW

Starts slow motion playback

CANCEL

Clear the input information

⑥ SUBTITLE

Shows the subtitle and selects different subtitle

RANDOM/ANGLE

Starts random playback/Switches the camera angle

AUDIO

Changes soundtracks

ZOOM

Changes zoom ratio

PROGRAM

Sets the playback order

1. Press \blacktriangle \blacktriangledown \blacktriangleleft \blacktriangleright to select the item.

2. Press 0 to 9 to specify the order.

To cancel: Press CANCEL.

3. Press \blacktriangle \blacktriangledown \blacktriangleleft \blacktriangleright to select PLAY.

To clear the whole program:

Press \blacktriangle \blacktriangledown \blacktriangleleft \blacktriangleright to select CLEAR.

4. Press OK.

USB

Switches to the USB mode / Returns to the disc mode

USB REC

Performs USB REC (CD Ripping)

⑦ Disc tray

When inserting a media, ensure that it is facing the right way up.

⑧ USB port

Connects a USB device

⑨ POWER LED

Lights when the power is turned on.

6 Operating Instruction

6.1. Take out the Disc from Drive Unit when the Disc cannot be ejected by the OPEN/CLOSE button

6.1.1. When the Disc Eject can not be done.

1. Turn off the power and pull out AC cord.
2. Refer to 9.1.7 about removing the Mechanism Unit.
3. Put the Mechanism Unit so that the bottom can be seen.
4. Slide A point in the direction of the arrow B by hand to eject the tray.

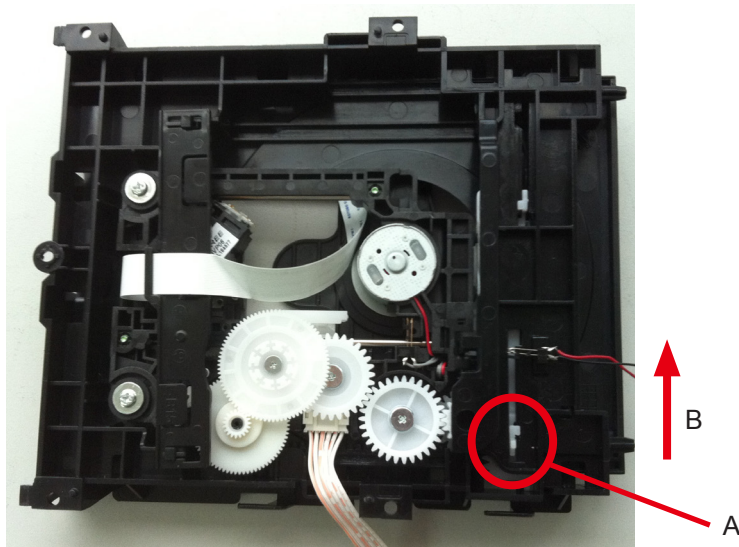

5. Pull the tray in the direction of the arrow and take out the disc.

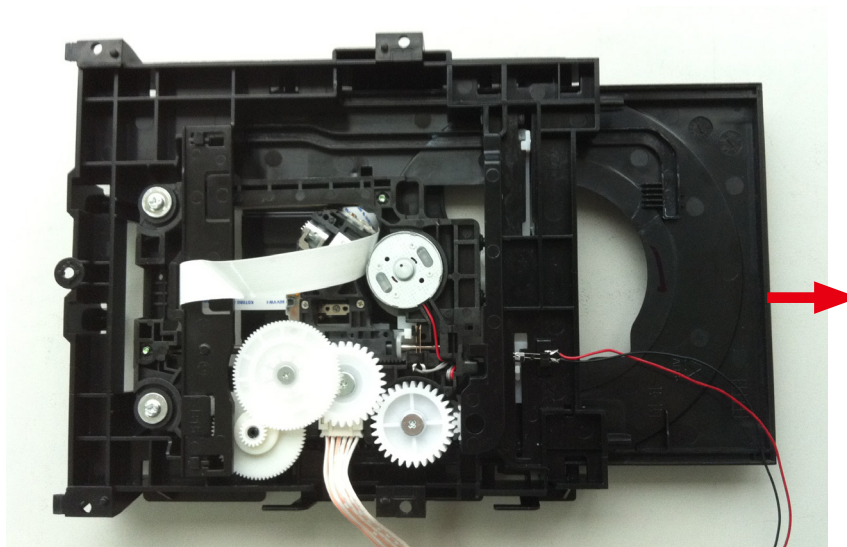

7 Troubleshooting Guide

7.1. About Operation of Set

To reset

Images from this DVD player do not appear on the television.

You forget your password.

⇒Reset the DVD player to the factory defaults.

1) Press \odot /I on the DVD player to turn it on.

2) Press **OPEN/CLOSE** \blacktriangle to open the disc tray.

3) Press the number button "5" on the remote control 4 times.

(The power is automatically turned off.)

All the settings return to the factory presets.

No picture./No sound.

⇒Check the video connection between the DVD player and the TV.

⇒Turn on your TV and set to the correct in channel for the DVD player.

Remote control does not work.

⇒Aim the remote control directly at the sensor on the front of the DVD player.

The screen is distorted. Noise occurs.

⇒Check if the TV System setting is correct.

Discs cannot be played back.

⇒Check for any scratches or smudges on the disc. If the disc is dirty, clean the disc.

Not able to select some items in the setup/system menu.

⇒Press **STOP** \blacksquare twice before selecting the setup/system menu.

⇒Depending on the disc availability, some menu items cannot be selected.

7.2. About Circuit

Symptom -1

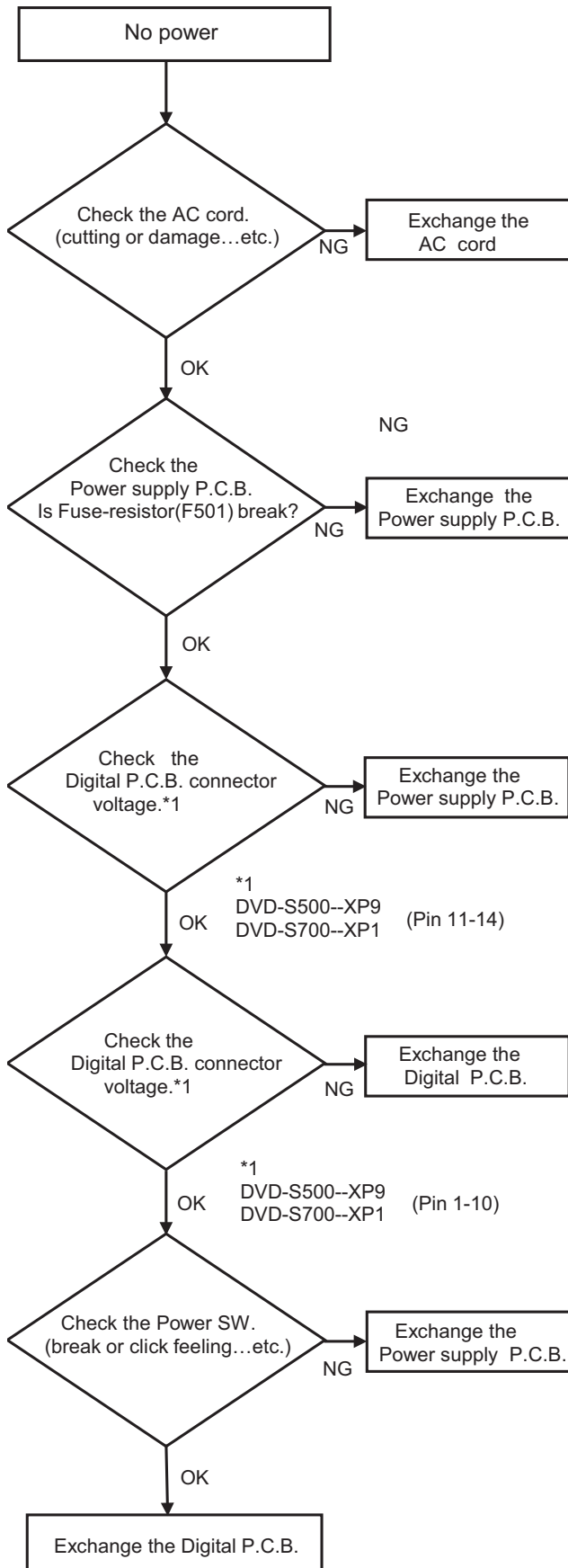

Symptom -2

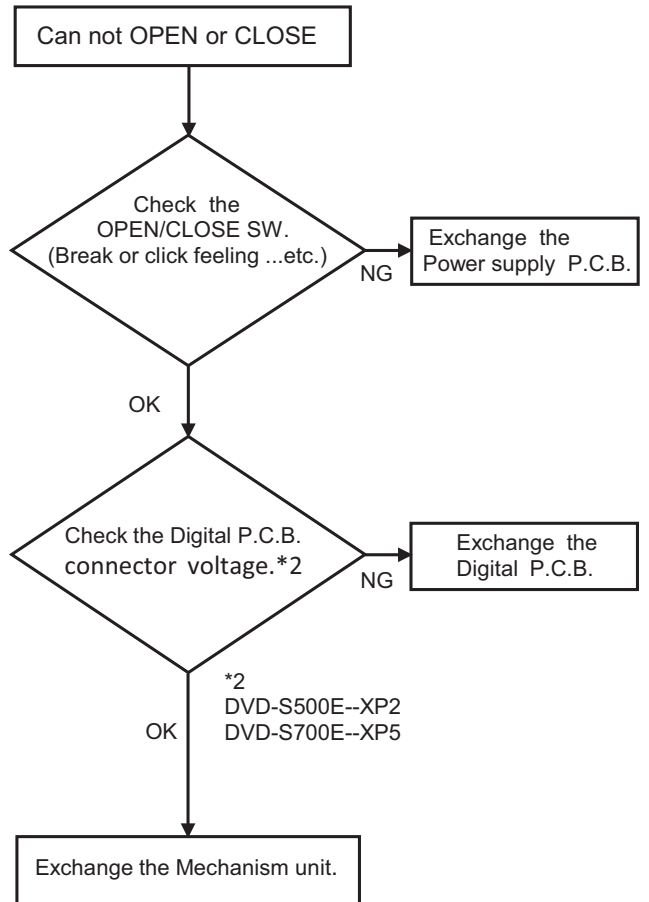

VOLTAGE DATA (measurement value)

REF.NO.	PIN NO.	S500E	S700E
*1	1	0V	0V
	2	0V	0V
	3	GND	GND
	4	5.1V	5.1V
	5	GND	GND
	6	3.5V	3.5V
	7	0V	0.6V
	8	3.3V	5.09V
	9	3.2V	3.2V
	10	3.3V	5.1V
	11	5.1V	5.1V
	12	12V	12V
	13	NC	NC
	14	GND	GND

REF.NO.	PIN NO.	DVD-S500/S700
*2	1	GND
	2	3.3V

Symptom -3

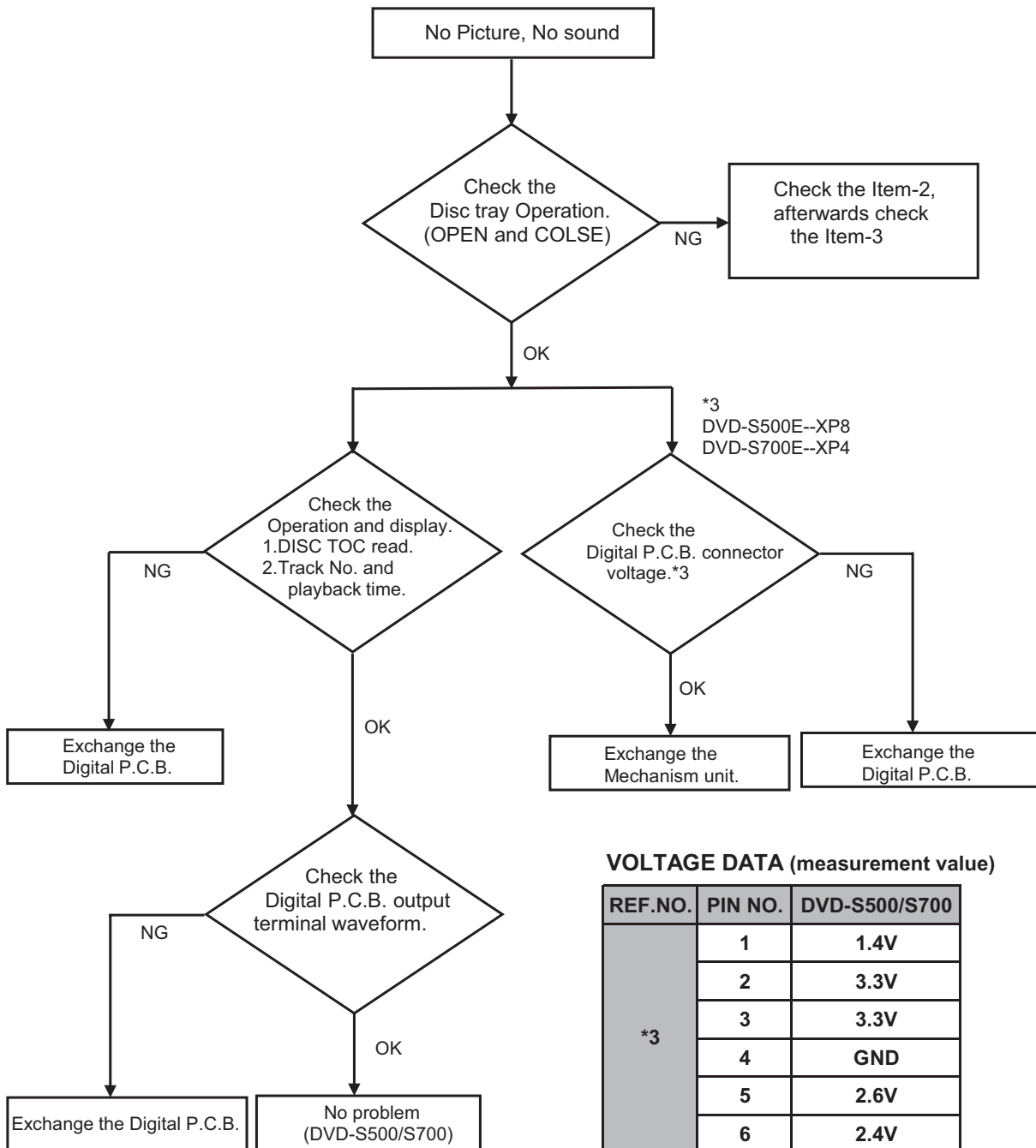

VOLTAGE DATA (measurement value)

REF.NO.	PIN NO.	DVD-S500/S700
*3	1	1.4V
	2	3.3V
	3	3.3V
	4	GND
	5	2.6V
	6	2.4V

8 Wiring Connection and Voltage Data

8.1. DVD-S500

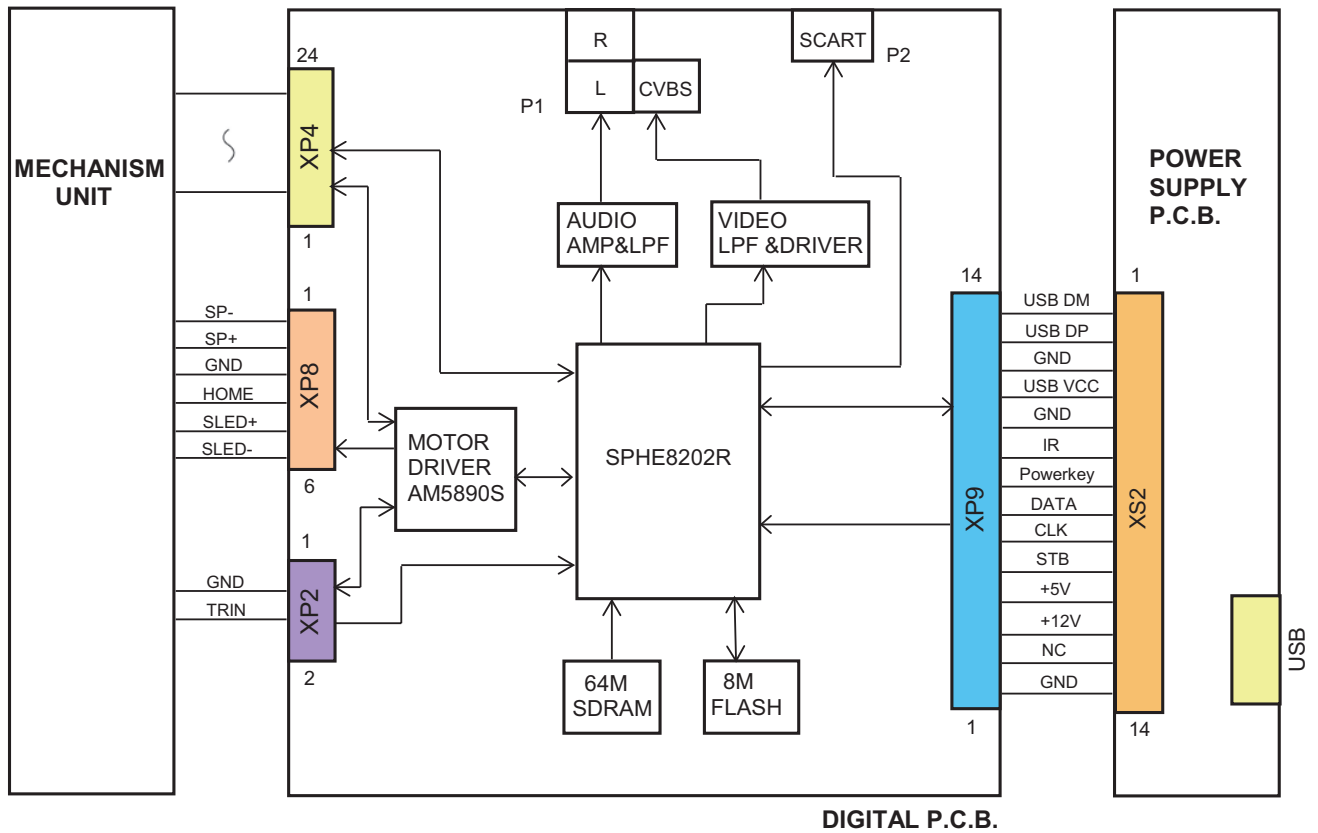

DVD-S500 VOLTAGE DATA (measurement value)

REF.NO.	PIN NO.	VALUE
XP8	1	1.4V
	2	3.3V
	3	3.3V
	4	GND
	5	2.6V
	6	2.4V

REF.NO.	PIN NO.	VALUE
XP2	1	GND
	2	3.3V

REF.NO.	PIN NO.	VALUE
XP9	1	0V
	2	0V
	3	GND
	4	5.1V
	5	GND
	6	3.5V
	7	0V
	8	3.3V
	9	3.2V
	10	3.3V
	11	5.1V
	12	12V
	13	NC
	14	GND

8.2. DVD-S700

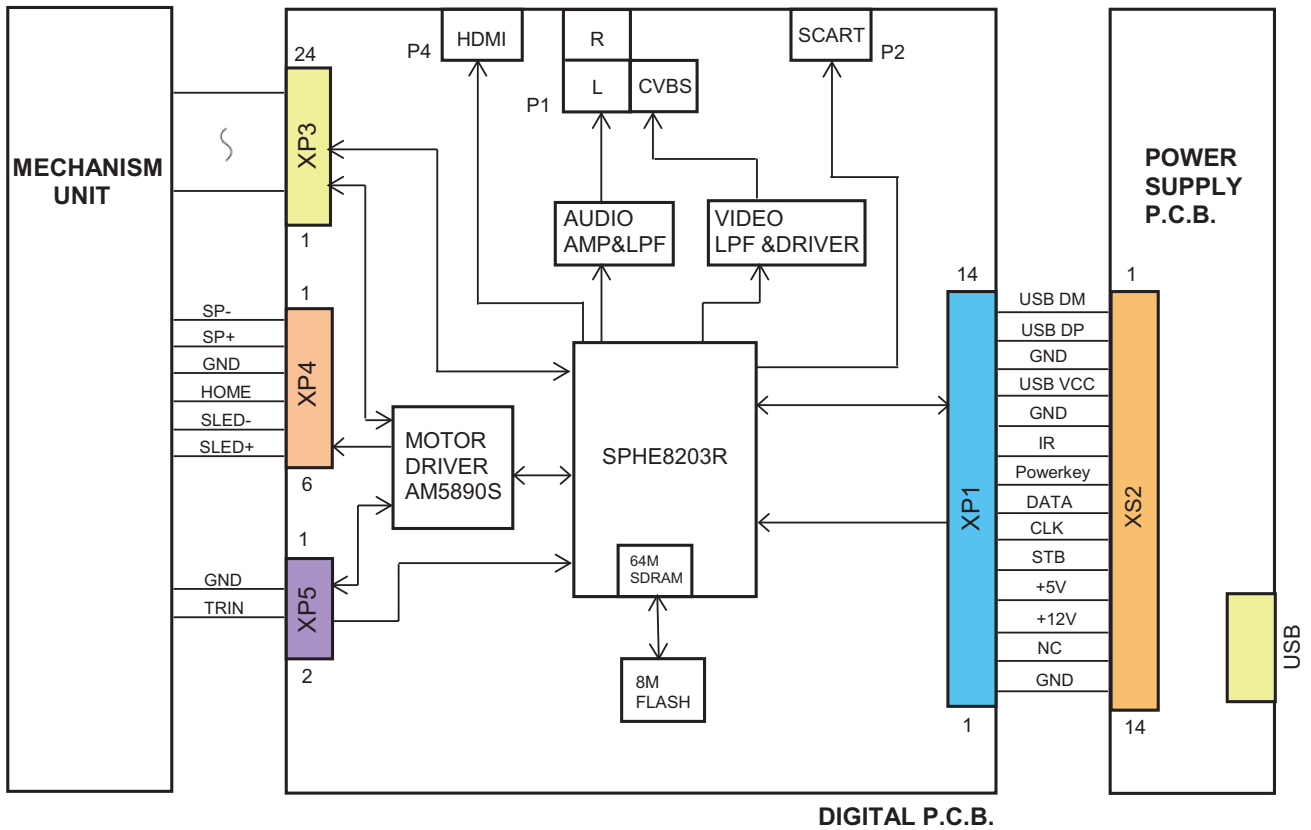

DVD-S700 VOLTAGE DATA (measurement value)

REF.NO.	PIN NO.	VALUE
XP4	1	1.4V
	2	3.3V
	3	3.3V
	4	GND
	5	2.6V
	6	2.4V

REF.NO.	PIN NO.	VALUE
XP5	1	GND
	2	3.3V

REF.NO.	PIN NO.	VALUE
XP1	1	0V
	2	0V
	3	GND
	4	5.1V
	5	GND
	6	3.5V
	7	0.6V
	8	5.09V
	9	3.2V
	10	5.1V
	11	5.1V
	12	12V
	13	NC
	14	GND

9 Disassembly and Assembly Instructions

9.1. Unit (DVD-S500/S700)

9.1.1. Disassembly Flow Chart

The following chart is the procedure of disassembling the casing and inside parts for internal inspection when carrying out the servicing.

To assemble the unit, reverse the steps shown in the chart below.

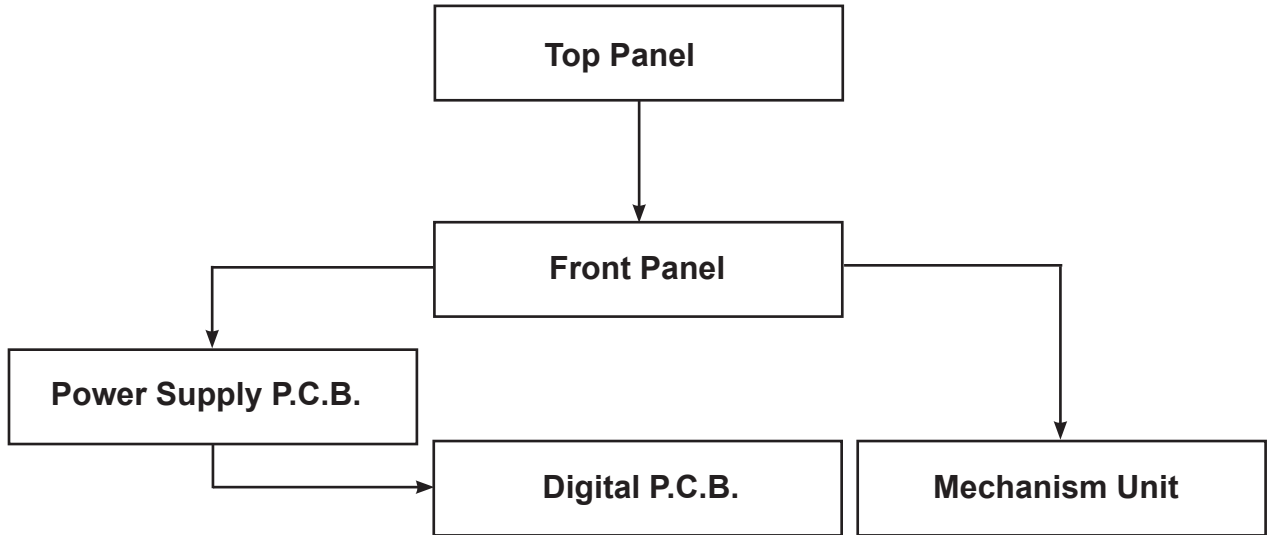

9.1.2. P.C.B. Positions

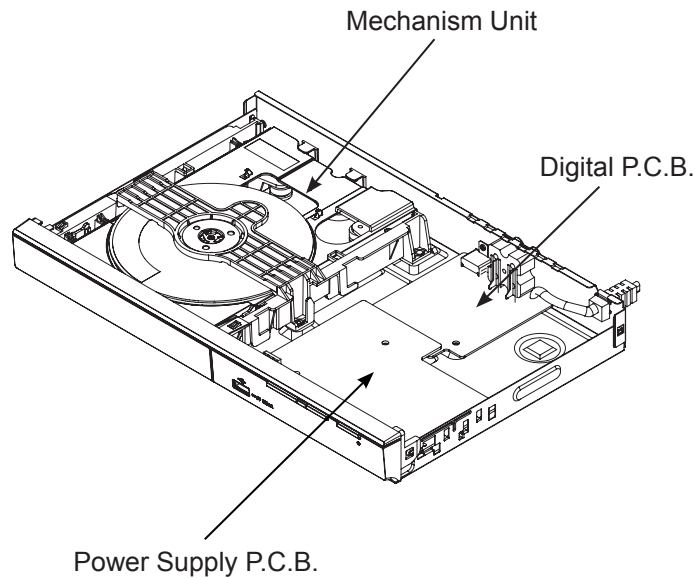

9.1.3. Top Panel

1. Remove the 2 Screws (A).
2. Expanded the both ends of the back of the top panel in the direction of arrow (1), and then remove it by pulling up in the direction of arrow (2).

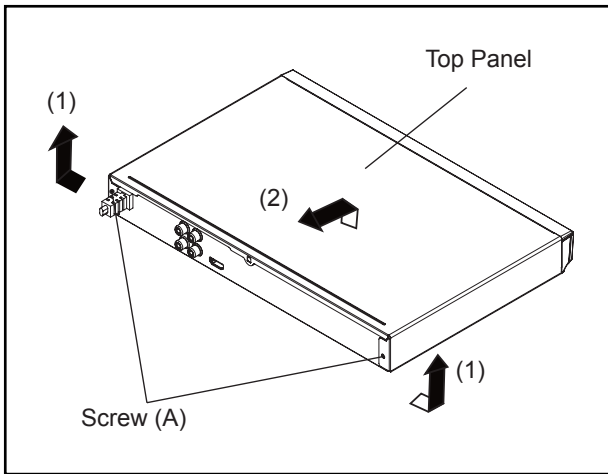

3. Remove the Front Panel.

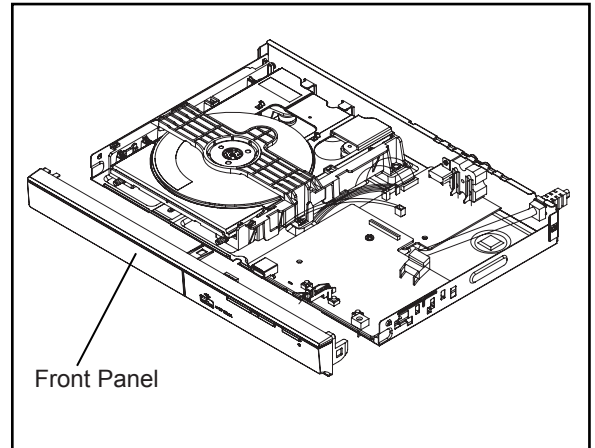

9.1.4. Front Panel

1. Unlock 2 tabs.
2. Unlock 3 tabs.

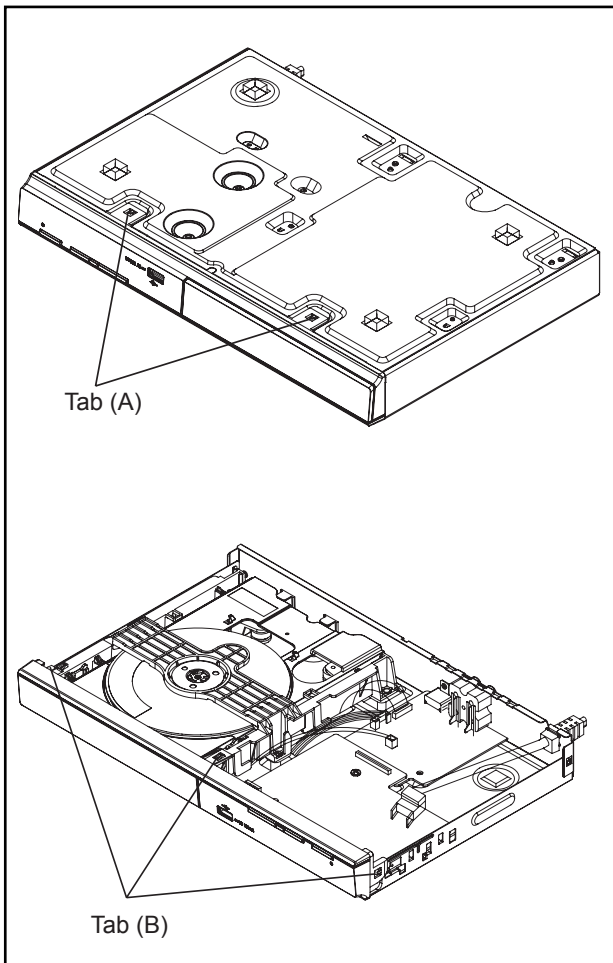

9.1.5. Power Supply P.C.B.

1. Remove the 1 Screw (A).
2. Remove the AC cord.
3. Lift up straight upward the Power Supply P.C.B. and disconnect the connector (A) to remove the Power Supply P.C.B..

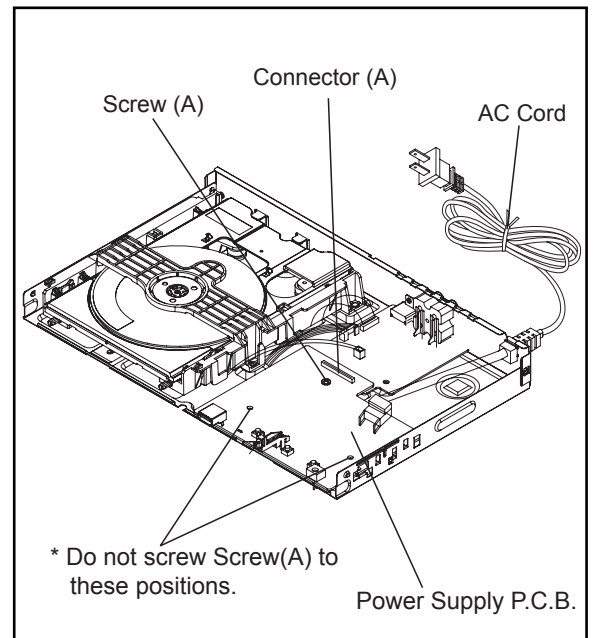

9.1.6. Digital P.C.B.

1. Refer to 9.1.5 to remove the Power Supply P.C.B..
2. Remove the FFC.
3. Remove the Wire with Connector (B) (6P).
4. Remove the Wire with Connector (C) (2P).
5. Remove the Digital P.C.B..

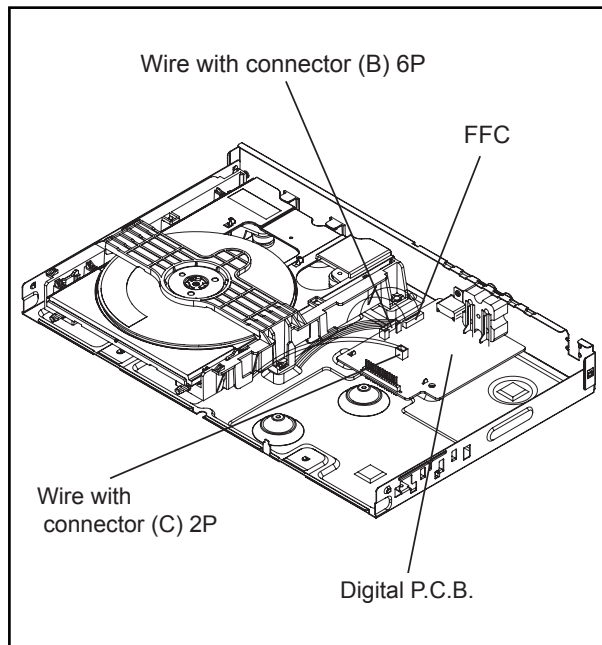

9.1.7. Mechanism Unit

1. Remove the FFC.
2. Remove the Wire with Connector (B) and the Wire with Connector (C).
3. Remove the Mechanism Unit.
(When assembling, firstly set the Mechanism unit to 2 Gaps (D) and tabs of Bottom Cabinet.)

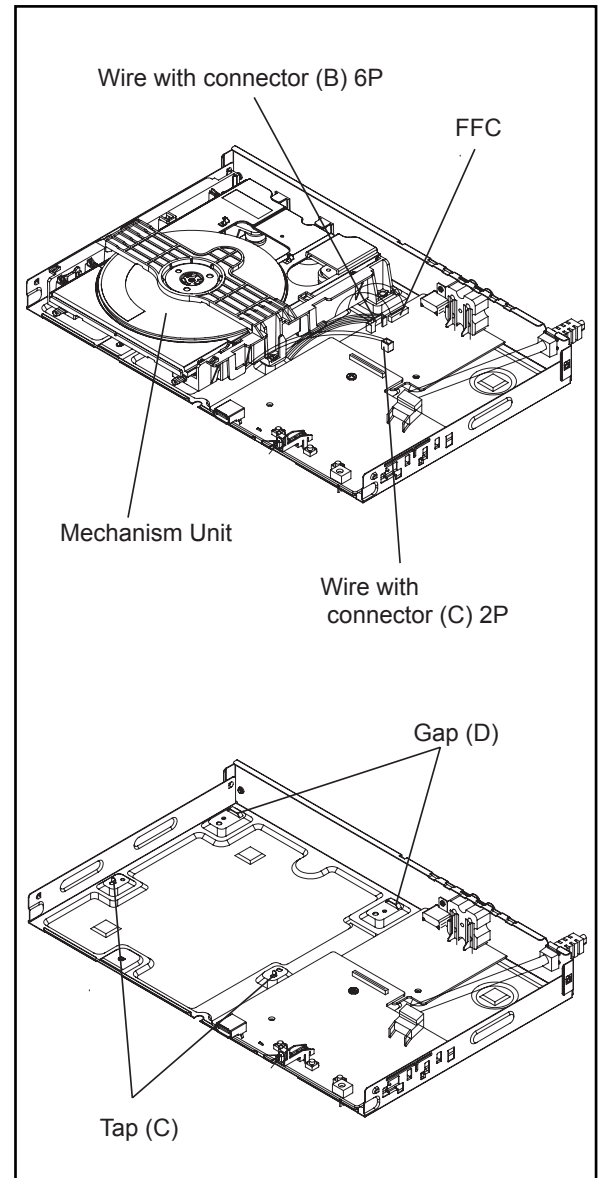

10 Exploded View and Replacement Parts List

10.1. Casing Parts & Mechanism Section

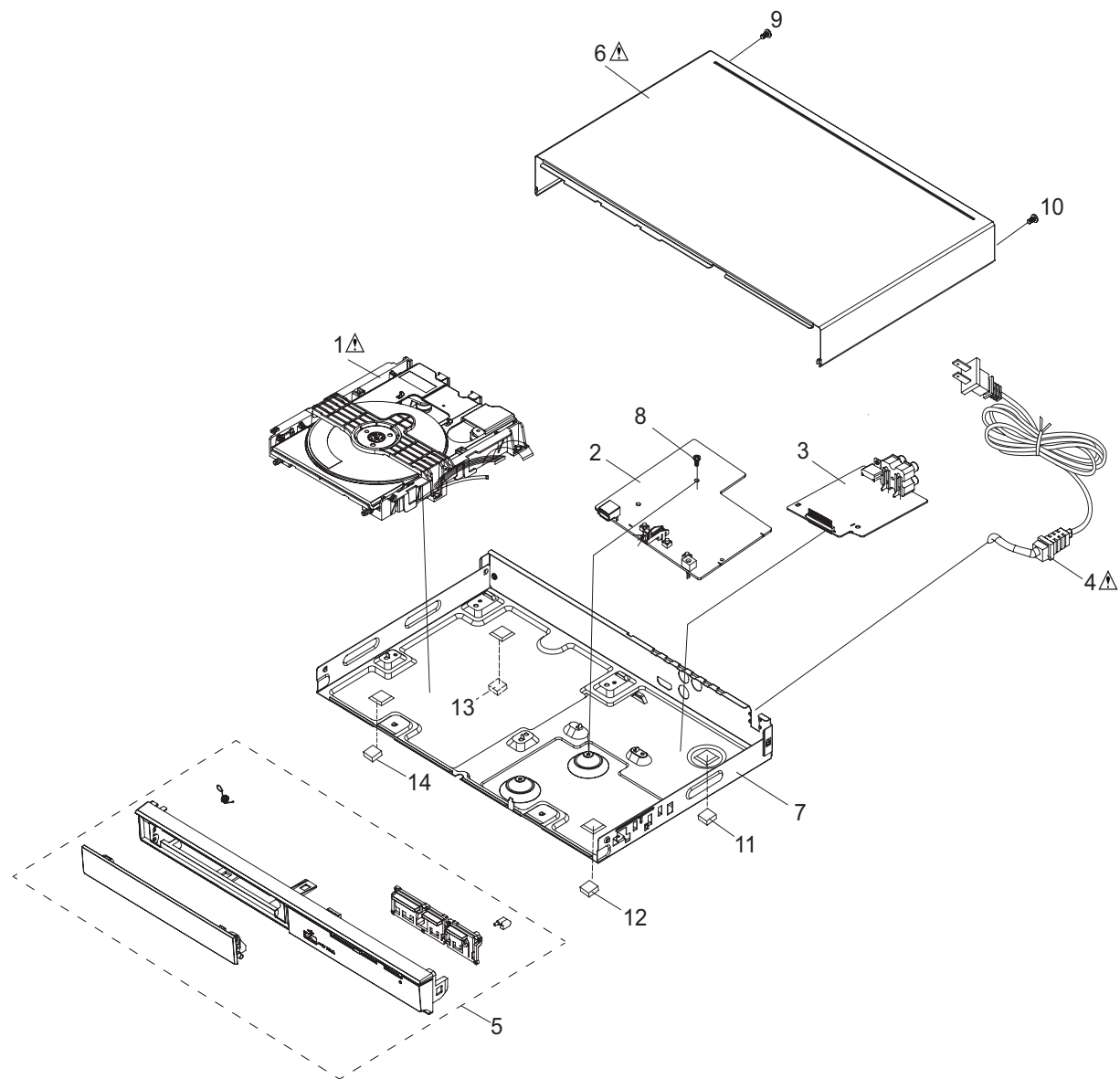

* Above illustration is for DVD-S500/S700 Series.

10.2. Packing & Accessories Section

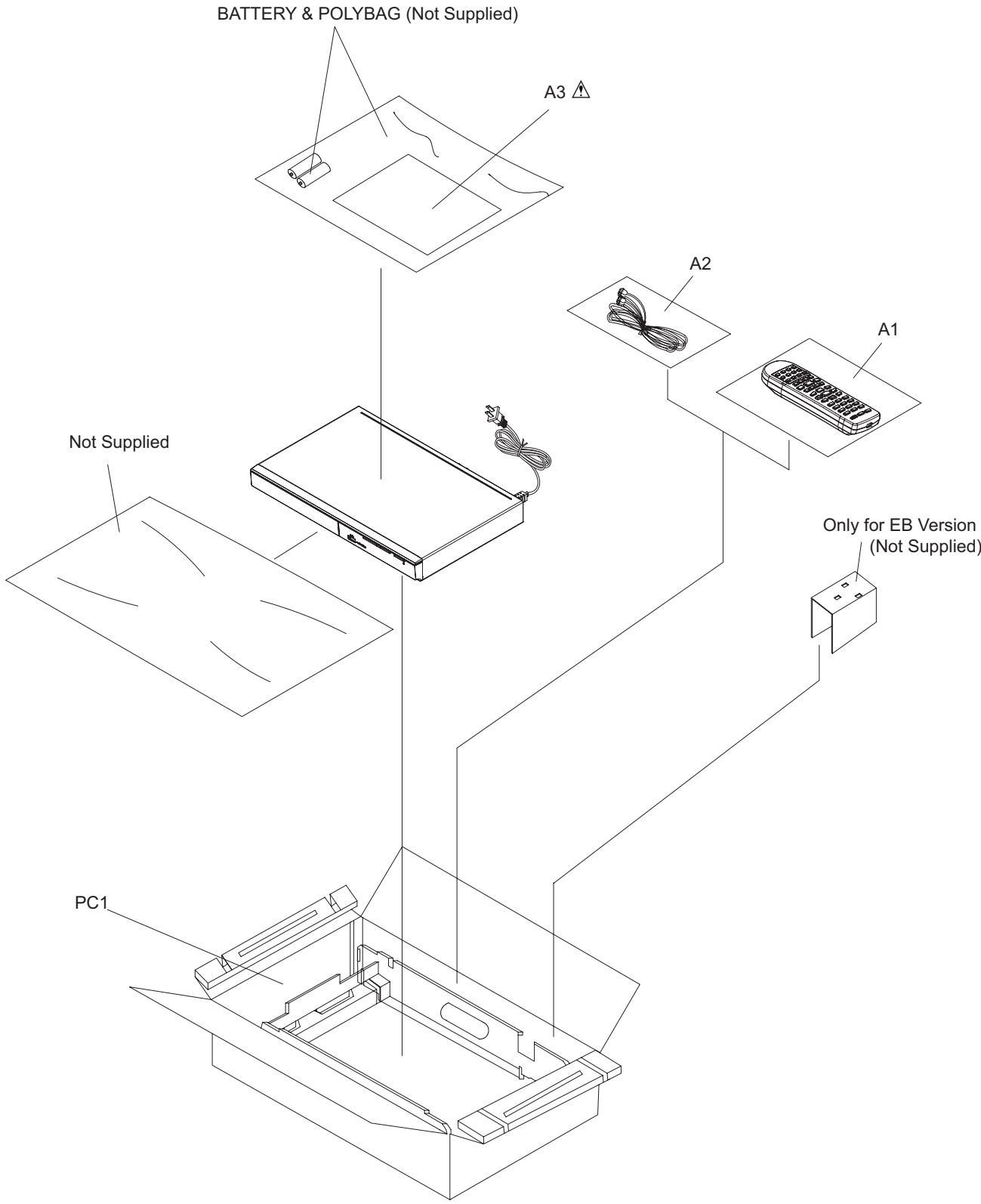

10.3. Replacement Parts List







Notes:

*Important safety notice:

Components identified by  mark have special characteristics important for safety.

When replacing any of components, be sure to use only manufacture's specified parts shown in the parts list.

*All parts are supplied by PAVCJM.

Safety	Ref. No.	Part No.	Part Name & Description	Pcs	Remarks
	1	VXY2196	MECHANISM UNIT	1	S700EP
	1	VXY2197	MECHANISM UNIT	1	S500EB/EG/EP
	2	VEP71335A	POWER SUPPLY P.C.B.UNIT	1	E.S.D. S500EB/EG/EP
	2	VEP71338A	POWER SUPPLY P.C.B.UNIT	1	E.S.D. S700EP
	3	VEP73284A	DIGITAL P.C.B.UNIT	1	E.S.D. S500EB
	3	VEP73285A	DIGITAL P.C.B.UNIT	1	E.S.D. S500EG
	3	VEP73286A	DIGITAL P.C.B.UNIT	1	E.S.D. S500EP
	3	VEP73291A	DIGITAL P.C.B.UNIT	1	E.S.D. S700EP
	4	K2CT3YY00075	AC CORD	1	S500EB
	4	K2CQ2YY00123	AC CORD	1	S500EG/EP/S700EP
	5	VGP6567	FRONT PANEL UNIT	1	S500EB/EG/EP
	5	VGP6569	FRONT PANEL UNIT	1	S700EP
	6	VGP6584	TOP PANEL	1	
	7	VKU0620	BOTTOM CABINET	1	S500EB/EG/EP
	7	VKU0625	BOTTOM CABINET	1	S700EP
	8	VHD2530	BLACK SCREW	1	
	9	VHD2530	BLACK SCREW	1	
	10	VHD2530	BLACK SCREW	1	
	11	VKA0415	RUBBER LEG	1	
	12	VKA0415	RUBBER LEG	1	
	13	VKA0415	RUBBER LEG	1	
	14	VKA0415	RUBBER LEG	1	
	A1	N2QAYA000015	REMOTE CONTROLLER	1	
	A2	K2KA2BA00003	AV CABLE	1	
	A3	VQT5C25	OPERATING INSTRUCTIONS	1	S500EG
	A3	VQT5C26	OPERATING INSTRUCTIONS	1	S500EP/S700EP
	A3	VQT5C27	OPERATING INSTRUCTIONS	1	S500EB/EP/S700EP
	PC1	RPG0H15	PACKING CASE	1	S500EG
	PC1	RPG0H16	PACKING CASE	1	S500EP
	PC1	RPG0H17	PACKING CASE	1	S500EB
	PC1	RPG0H24	PACKING CASE	1	S700EP