

Service Manual

SD Card Video Camera



Model No. **SDR-S26P**

SDR-S26PC

SDR-S26EG

SDR-S26EE

SDR-S26EB

SDR-S26EP

SDR-S26EF

SDR-S26EC

SDR-S26GC9

SDR-S26GN

SDR-S26GJ

SDR-S26GK

SDR-S26PU

SDR-S26PR

SDR-S26GT

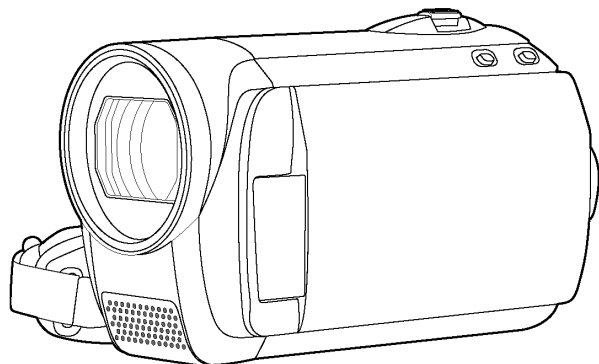

VOL.1

Colours

(K).....Black Type

(N).....Gold Type (except SDR-S26EF)

(A).....Blue Type (except SDR-S26EE/PR/GK)

(R).....Red Type (except SDR-S26EE/GT/PR)

⚠ WARNING

This service information is designed for experienced repair technicians only and is not designed for use by the general public. It does not contain warnings or cautions to advise non-technical individuals of potential dangers in attempting to service a product. Products powered by electricity should be serviced or repaired only by experienced professional technicians. Any attempt to service or repair the product or products dealt with in this service information by anyone else could result in serious injury or death.

CONTENTS

	Page		Page
1 Safety Precaution	3	9.1. EEPROM Data for spare parts of the SUB P.C.B.	24
1.1. General Guidelines	3	9.2. Service Positions	24
2 Warning	4	9.3. Location for Connectors of the Main P.C.B. and Sub P.C.B.	26
2.1. Prevention of Electrostatic Discharge (ESD) to Electrostatic Sensitive (ES) Devices	4	9.4. Electrical Adjustment Procedures	28
2.2. Service caution based on legal restrictions	5	10 Maintenance	32
2.3. Caution for AC Cord (For EB/GC9)	6	10.1. Cleaning Lens and LCD Panel	32
2.4. How to Replace the Lithium Battery (PROCEDURE)	7	11 Schematic Diagrams	33
2.5. How to Recycle the Lithium Battery (U.S. Only)	8	11.1. OVERALL SCHEMATIC DIAGRAM	33
3 Service Navigation	9	11.2. INTERCONNECTION SCHEMATIC DIAGRAM	34
3.1. Service Information	9	11.3. REAR SCHEMATIC DIAGRAM	36
4 Specifications	10	11.4. LCD BL SCHEMATIC DIAGRAM	37
5 Location of Controls and Components	11	11.5. LCD SHAFT FPC SCHEMATIC DIAGRAM	38
6 Service Mode	14	11.6. TERMINAL FPC SCHEMATIC DIAGRAM	39
6.1. Service Menu	14	11.7. LCD OPERATION UNIT SCHEMATIC DIAGRAM	39
6.2. About Default Setting	16	11.8. ECM FPC SCHEMATIC DIAGRAM	40
7 Service Fixture & Tools	17	11.9. MODE OPERATION SCHEMATIC DIAGRAM	40
7.1. Service Tools and Equipment	17	11.10. CCD SCHEMATIC DIAGRAM	41
8 Disassembly and Assembly Instructions	18	12 Printed Circuit Board	43
8.1. Disassembly Flow Chart	18	12.1. LCD BL P.C.B.	43
8.2. P.C.B. Layout	18	12.2. REAR P.C.B.	44
8.3. Disassembly Procedures	19	13 Parts and Exploded Views	45
8.4. Disassembly Procedures of Camera Lens Unit	23	13.1. Exploded Views	45
9 Measurements and Adjustments	24	13.2. Replacement Parts List	49

1 Safety Precaution

1.1. General Guidelines

1. IMPORTANT SAFETY NOTICE

There are special components used in this equipment which are important for safety. These parts are marked by in the Schematic Diagrams, Circuit Board Layout, Exploded Views and Replacement Parts List. It is essential that these critical parts should be replaced with manufacturer's specified parts to prevent X-RADIATION, shock fire, or other hazards. Do not modify the original design without permission of manufacturer.

2. An Isolation Transformer should always be used during the servicing of AC Adaptor whose chassis is not isolated from the AC power line. Use a transformer of adequate power rating as this protects the technician from accidents resulting in personal injury from electrical shocks. It will also protect AC Adaptor from being damaged by accidental shorting that may occur during servicing.
3. When servicing, observe the original lead dress. If a short circuit is found, replace all parts which have been overheated or damaged by the short circuit.
4. After servicing, see to it that all the protective devices such as insulation barriers, insulation papers shields are properly installed.
5. After servicing, make the following leakage current checks to prevent the customer from being exposed to shock hazards.

1.1.1. Leakage Current Cold Check

1. Unplug the AC cord and connect a jumper between the two prongs on the plug.
2. Measure the resistance value, with an ohmmeter, between the jumpered AC plug and each exposed metallic cabinet part on the equipment such as screwheads, connectors, control shafts, etc. When the exposed metallic part has a return path to the chassis, the reading should be between $1M\Omega$ and $5.2M\Omega$. When the exposed metal does not have a return path to the chassis, the reading must be infinity.

1.1.2. Leakage current hot check (See Figure 1)

1. Plug the AC cord directly into the AC outlet. Do not use an isolation transformer for this check.
2. Connect "A" to exposed metallic part on the set. And connect "B" to a good earth ground, as shown in Figure 1.
3. Use an AC voltmeter, with $1\text{ k}\Omega/\text{V}$ or more sensitivity, to measure the potential across the resistor.
4. Check each exposed metallic part, and measure the voltage at each point.
5. Reverse the AC plug in the AC outlet and repeat each of the above measurements.
6. The potential at any point should not exceed 0.25 V RMS.

A leakage current tester (Simpson Model 229 or equivalent) may be used to make the hot checks, leakage current must not exceed $1/2\text{ mA}$. In case a measurement is outside of the limits specified, there is a possibility of a shock hazard, and the equipment should be repaired and rechecked before it is returned to the customer.

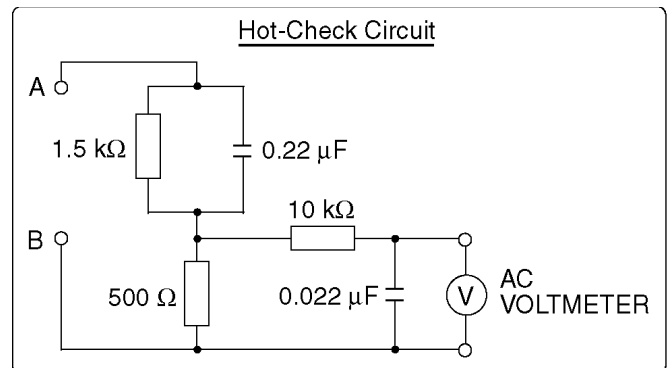

Figure 1

2 Warning

2.1. Prevention of Electrostatic Discharge (ESD) to Electrostatic Sensitive (ES) Devices

Some semiconductor (solid state) devices can be damaged easily by static electricity. Such components commonly are called Electrostatic Sensitive (ES) Devices. Examples of typical ES devices are integrated circuits and some field-effect transistors and semiconductor “chip” components. The following techniques should be used to help reduce the incidence of component damage caused by electrostatic discharge (ESD).

1. Immediately before handling any semiconductor component or semiconductor-equipped assembly, drain off any ESD on your body by touching a known earth ground. Alternatively, obtain and wear a commercially available discharging ESD wrist strap, which should be removed for potential shock reasons prior to applying power to the unit under test.
2. After removing an electrical assembly equipped with ES devices, place the assembly on a conductive surface such as aluminum foil, to prevent electrostatic charge buildup or exposure of the assembly.
3. Use only a grounded-tip soldering iron to solder or unsolder ES devices.
4. Use only an antistatic solder removal device. Some solder removal devices not classified as “antistatic (ESD protected)” can generate electrical charge sufficient to damage ES devices.
5. Do not use freon-propelled chemicals. These can generate electrical charges sufficient to damage ES devices.
6. Do not remove a replacement ES device from its protective package until immediately before you are ready to install it. (Most replacement ES devices are packaged with leads electrically shorted together by conductive foam, aluminum foil or comparable conductive material).
7. Immediately before removing the protective material from the leads of a replacement ES device, touch the protective material to the chassis or circuit assembly into which the device will be installed.

CAUTION:

Be sure no power is applied to the chassis or circuit, and observe all other safety precautions.

8. Minimize bodily motions when handling unpackaged replacement ES devices. (Otherwise harmless motion such as the brushing together of your clothes fabric or the lifting of your foot from a carpeted floor can generate static electricity (ESD) sufficient to damage an ES device).

IMPORTANT SAFETY NOTICE

There are special components used in this equipment which are important for safety. These parts are marked by Δ in the schematic diagrams, Exploded Views and replacement parts list. It is essential that these critical parts should be replaced with manufacturer's specified parts to prevent shock, fire, or other hazards. Do not modify the original design without permission of manufacturer.

2.2. Service caution based on legal restrictions

2.2.1. General description about Lead Free Solder (PbF)

The lead free solder has been used in the mounting process of all electrical components on the printed circuit boards used for this equipment in considering the globally environmental conservation.

The normal solder is the alloy of tin (Sn) and lead (Pb). On the other hand, the lead free solder is the alloy mainly consists of tin (Sn), silver (Ag) and Copper (Cu), and the melting point of the lead free solder is higher approx.30 degrees C (86°F) more than that of the normal solder.

Definition of PCB Lead Free Solder being used

The letter of "PbF" is printed either foil side or components side on the PCB using the lead free solder. (See right figure)	PbF
---	------------

Service caution for repair work using Lead Free Solder (PbF)

- The lead free solder has to be used when repairing the equipment for which the lead free solder is used.
(Definition: The letter of "PbF" is printed on the PCB using the lead free solder.)
- To put lead free solder, it should be well molten and mixed with the original lead free solder.
- Remove the remaining lead free solder on the PCB cleanly for soldering of the new IC.
- Since the melting point of the lead free solder is higher than that of the normal lead solder, it takes the longer time to melt the lead free solder.
- Use the soldering iron (more than 70W) equipped with the temperature control after setting the temperature at 350±30 degrees C (662±86°F).

Recommended Lead Free Solder (Service Parts Route.)

- The following 3 types of lead free solder are available through the service parts route.
 - RFKZ03D01KS----- (0.3mm 100g Reel)
 - RFKZ06D01KS----- (0.6mm 100g Reel)
 - RFKZ10D01KS----- (1.0mm 100g Reel)

Note

* Ingredient: tin (Sn), 96.5%, silver (Ag) 3.0%, Copper (Cu) 0.5%, Cobalt (Co) / Germanium (Ge) 0.1 to 0.3%

2.3. Caution for AC Cord (For EB/GC9)

2.3.1. Information for your safety

IMPORTANT

Your attention is drawn to the fact that recording of pre-recorded tapes or discs or other published or broadcast material may infringe copyright laws.

WARNING

To reduce the risk of fire or shock hazard, do not expose this equipment to rain or moisture.

CAUTION

To reduce the risk of fire or shock hazard and annoying interference, use the recommended accessories only.

FOR YOUR SAFETY

DO NOT REMOVE THE OUTER COVER

To prevent electric shock, do not remove the cover. No user serviceable parts inside. Refer servicing to qualified service personnel.

2.3.2. Caution for AC mains lead

For your safety, please read the following text carefully.

This appliance is supplied with a moulded three-pin mains plug for your safety and convenience.

A 5-ampere fuse is fitted in this plug.

Should the fuse need to be replaced please ensure that the replacement fuse has a rating of 5 amperes and it is approved by ASTA or BSI to BS1362

Check for the ASRA mark or the BSI mark on the body of the fuse.



If the plug contains a removable fuse cover you must ensure that it is refitted when the fuse is replaced.

If you lose the fuse cover, the plug must not be used until a replacement cover is obtained.

A replacement fuse cover can be purchased from your local Panasonic Dealer.

If the fitted moulded plug is unsuitable for the socket outlet in your home then the fuse should be removed and the plug cut off and disposed of safely.

There is a danger of severe electrical shock if the cut off plug is inserted into any 13-ampere socket.

If a new plug is to be fitted please observe the wiring code as shown below.

If in any doubt, please consult a qualified electrician.

2.3.2.1. Important

The wires in this mains lead are coloured in accordance with the following code:

Blue	Neutral
Brown	Live

As the colours of the wires in the mains lead of this appliance may not correspond with the coloured markings identifying the terminals in your plug, proceed as follows:

The wire which is coloured BLUE must be connected to the terminal in the plug which is marked with the letter N or coloured BLACK.

The wire which is coloured BROWN must be connected to the terminal in the plug which is marked with the letter L or coloured RED.

Under no circumstances should either of these wires be connected to the earth terminal of the three pin plug, marked with the letter E or the Earth Symbol.

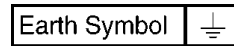

2.3.2.2. Before use

remove the Connector Cover as follows.

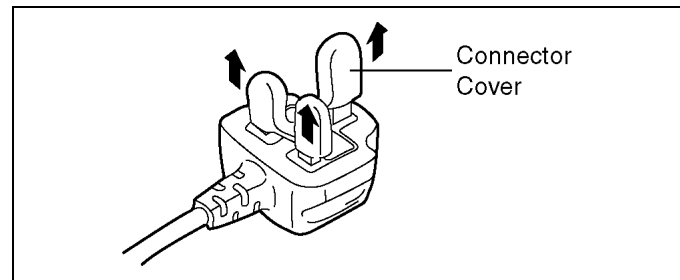

2.3.2.3. How to replace the Fuse

1. Remove the Fuse Cover with a screwdriver.

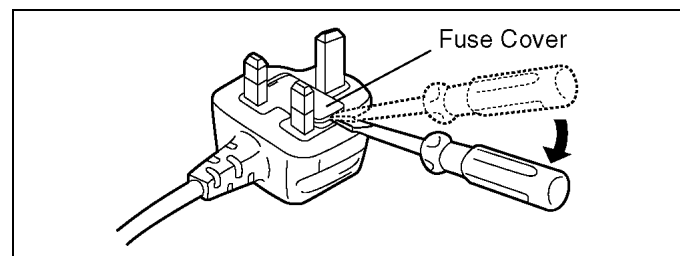

2. Replace the fuse and attach the Fuse cover.

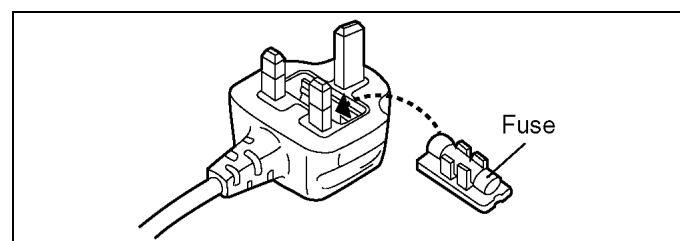

2.4. How to Replace the Lithium Battery (PROCEDURE)

1. Remove the LCD BL P.C.B.. (Refer to Disassembly Procedures.)
2. Remove the Lithium Battery "ML-614S/ZTE" and then replace the new one. (See .)

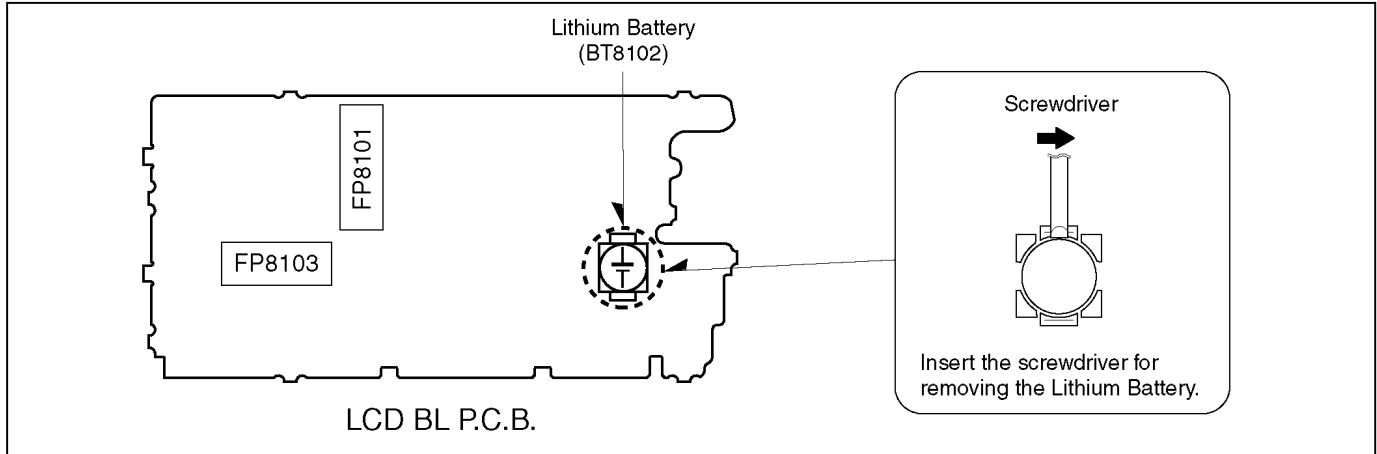

CAUTION

Danger of explosion if battery is incorrectly replaced.
Replace only with the same or equivalent type.

CAUTION

The battery used in this device may present a risk of fire or chemical burn if mistreated.
Do not recharge, disassemble, heat above 100°C (212 F), or incinerate.
Replace battery with Panasonic part number ML-614S/ZTE only.
Use of another battery may present a risk of fire or explosion.
Dispose of used battery promptly.
Keep away from children.
Do not disassemble and do not dispose of in fire.

Fig. B1

Note:

The lithium battery is a critical component. (Type No.: ML-614S/ZTE Manufactured by Panasonic.)

It must never be subjected to excessive heat or discharge.

It must therefore only be fitted in equipment designed specifically for its use.

Replacement batteries must be of the same type and manufacture.

They must be fitted in the same manner and location as the original battery, with the correct polarity contacts observed.

Do not attempt to re-charge the old battery or re-use it for any other purpose.

It should be disposed of in waste products destined for burial rather than incineration.

(For English)

CAUTION

Danger of explosion if battery is incorrectly replaced.
 Replace only with the same or equivalent type recommended by the equipment manufacturer.
 Discard used batteries according to manufacturer's instructions.

(For French)

PRECAUTION

Le fait de remplacer incorrectement la pile peut présenter des risques d'explosion.
 Remplacer la pile uniquement par une pile identique ou de type équivalent recommandée par le fabricant. Se débarrasser des piles usagées conformément aux instructions du fabricant.

(For German)

VORSICHT

Bei einer falsch eingesetzten Batterie besteht Explosionsgefahr. Nur mit einer vom gleichen Typ ersetzen.
 Verbrauchte Batterien beim Fachhändler oder einer Sammelstelle für Sonderstoffe abliefern.

(For Swedish)

VARNING

Explosionsfara vid felaktigt batteribyte.
 Använd samma batterityp eller en ekvivalent typ som rekommenderas av apparattillverkaren.
 Kassera använt batteri enligt fabrikantens instruktion.

(For Norwegian)

ADVARSEL!

Lithiumbatteri-Eksplosionsfare ved fejløgt håndtering.
 Udskiftning må kun ske med batteri af samme fabrikat og type.
 Levér det brugte batteri tilbage til leverandøren.

(For Finnish)

VAROITUS

Paristo voi räjähtää, jos se on virheellisesti asennettu.
 Vaihda paristo ainoastaan laitevalmistajan suosittelemaan tyyppiin.
 Hävitä käytetty paristo valmistajan ohjeiden mukaisesti.

2.5. How to Recycle the Lithium Battery (U.S. Only)**U.S.A./CANADA CONSUMERS: ATTENTION:**

A lithium ion/polymer battery that is recyclable powers the product you have purchased. Please call 1-800-8-BATTERY for information on how to recycle this battery.

3 Service Navigation

3.1. Service Information

This service manual contains technical information which will allow service personnel's to understand and service this model. Please place orders using the parts list and not the drawing reference numbers.

If the circuit is changed or modified, this information will be followed by supplement service manual to be filed with original service manual.

Notes 1:

1. VSK0694 is indicated on AC Adapter used on the following models:
SDR-S26P/PC.
2. VSK0695 is indicated on AC Adapter used in the following models:
SDR-S26EG/EB/EP/EF/EC/EE/GC9/GN/GJ/GK/GT/PU.
3. VSK0702 is indicated on AC Adapter used on the following model:
SDR-S26PR.
4. VSK0703 is indicated on AC Adapter used on the following model:
SDR-S26GT.

Notes 2:

- 1) This service manual does not contain the following information, because of the impossibility of servicing at component level.
 1. Schematic Diagram, Block Diagram and P.C.B. layout of Main P.C.B. and Sub P.C.B.
 2. Parts List for individual parts of Main P.C.B. and Sub P.C.B.
- 2) The following category are recycle module part. Please send them to Central Repair Center.
 - *Main P.C.B. (LSEP8462G1: SDR-S26GT/P/PC/PR/PU)
(LSEP8462U1: SDR-S26EG/EB/EP/EF/EC/EE/GC9/GN/GJ/GK)
 - *Sub P.C.B. (LSEP8474A1: SDR-S26P/PC/PR/PU)
(LSEP8474C1: SDR-S26GT)
(LSEP8474P1: SDR-S26EE/GC9/GJ/GK/GN)
(LSEP8474R1: SDR-S26EB/EC/EF/EG/EP)

When a part replacement is required for repairing each Main P.C.B. and Sub P.C.B., replace the assembly parts.
(Main P.C.B.)

The following circuits are contained in Main P.C.B.

1. Main Connection Circuit
 2. AVIO Circuit
 3. Video Circuit
 4. Memory Circuit
 5. USB Host Circuit
 6. LCD Circuit
 7. Resize Circuit
 8. KAO Circuit
 9. Lens Drive Circuit
 10. TG/AFE Circuit
 11. MIC Circuit
 12. Sub Power Circuit
- (Sub P.C.B.)

The following circuits are contained in Sub P.C.B.

1. Sub Connection Circuit
2. Power Circuit
3. G-Sensor Circuit
4. Sub SYSCON Circuit
5. SYSCON Circuit
6. Charge Circuit

4 Specifications

SD Card / Hard Disk Video Camera

ITEM	SPECIFICATION	ITEM	SPECIFICATION								
POWER	SD Video Camera: Power Source: DC 5.0/3.6 V Power Consumption: 3.0 W (Recording) 4.5 W (Charging) AC Adaptor: Power Source: AC 110-240 V, 50/60 Hz Power Consumption: 12 W DC Output: DC 5.0 V, 1.6 A	STILL PICTURES	Recording Media: SD Memory Card (removable type): 8 MB /16 MB /32 MB /64 MB /128 MB /256 MB / 512 MB /1 GB/2 GB (FAT12 and FAT16 format corresponding) SDHC Memory Card (removable type): 4 GB /6 GB /8 GB /12 GB /16 GB /32 GB (FAT32 format corresponding) Compression: JPEG (Design rule for Camera File system, based on Exif 2.2 standard), DPOF corresponding Picture Size: 640 × 480 (4:3), 640 × 360 (16:9)								
RECORDING FORMAT	Based on the SD-Video standard		STANDARD ILLUMINATION	1,400 lx							
CAMERA	Filter Diameter: 37.0mm		MINIMUM REQUIRED ILLUMINATION	Approx. 6 lx (1/30 in low light mode) (Approx. 2lx with the MagicPix function)							
	Zoom: 70X optical, 100X/3500X digital										
	Monitor: 2.7-inch wide LCD (approx. 123K pixels)										
	Lens: Auto Iris, F1.9-F5.7, Focal Length; 1.5 - 105 mm Macro (Full Range AF)										
	Image Sensor: 1/8-inch CCD Image Sensor										
VIDEO	Television System : EIA Standard : 525 Lines, 60 Fields NTSC Colour Signal (SDR-S26P/PC/PU/PR/GT) CCIR : 625 Lines, 50 Fields PAL Colour Signal (Except SDR-S26P/PC/PU/PR/GT)	USB	Card reader function (No copyright protection support) Hi-Speed USB (USB 2.0) compliant USB terminal Type Mini AB. PictBridge-compliant USB host function (for DVD burner)								
	Video Output Level: 1.0 Vp-p, 75 ohm (AV Multi Jack)	MICROPHONE	Stereo (with a zoom function)								
AUDIO	Audio Output Level (Line): 316 mV, 600 ohm (AV Multi Jack)	SPEAKER	1 round speaker φ15 mm								
MOTION PICTURES	Recording media: SD Memory Card (removable type) : 32 MB*1/64 MB*1/128 MB*1/256 MB/512 MB/1 GB/2 GB (FAT12 and FAT16 format corresponding) SDHC Memory Card (removable type) : 4 GB /6 GB /8 GB /12 GB /16 GB /32 GB (FAT32 format corresponding) Compression: MPEG-2 Recording mode and transfer rate: XP: 10 Mbps (VBR) SP: 5 Mbps (VBR) LP: 2.5 Mbps (VBR) Recordable time: Approx. <table border="1" data-bbox="305 1182 521 1276"> <thead> <tr> <th></th> <th>SD Card (1GB)</th> </tr> </thead> <tbody> <tr> <td>XP</td> <td>12 minutes</td> </tr> <tr> <td>SP</td> <td>25 minutes</td> </tr> <tr> <td>LP</td> <td>50 minutes</td> </tr> </tbody> </table> Audio compression: Dolby Digital/MPEG-1 Audio Layer 2, 16bit (48 kHz/2 ch) Maximum number of recordable folders and scenes: SD card: 99 folders × 99 scenes (9801 scenes) (When the date changes, a new folder is created and scenes are recorded in this new folder even if the number of scenes in the old folder has not reached 99.)		SD Card (1GB)	XP	12 minutes	SP	25 minutes	LP	50 minutes	OPERATING TEMPERATURE	0°C - 40°C (32°F - 104°F)
			SD Card (1GB)								
		XP	12 minutes								
		SP	25 minutes								
		LP	50 minutes								
		OPERATING HUMIDITY	10% - 80%								
		OPERATING ALTITUDE	Less than 3000 m (9800 feet) above sea level								
		Mass (WEIGHT)	SD Video Camera: 235 g (0.52lbs) (without battery and SD card) AC Adaptor: 100 g (0.22 lbs)								
		DIMENSIONS	SD Video Camera: (excluding the projecting parts) 56 mm (W) × 65 mm (H) × 107 mm (D) 2.21 inch (W) × 2.56 inch (H) × 4.21 inch (D) AC Adaptor: 76 mm (H) × 22 mm (H) × 46 mm (D) 2.99 inch (W) × 0.87 inch (H) × 1.81 inch (D)								
		STANDARD ACCESSORIES	1 pc. AC Adaptor 1 pc. Battery Pack Unit 1 pc. AC Cord (Except SDR-S26GC9) 2 pcs. AC Cord (SDR-S26GC9) 1 pc. AV Cable 1 pc. CD-ROM 1 pc. USB Cable								
SOLDER	This model use lead free solder (PbF).										

*1 Cannot be guaranteed in operation.

Weight and dimensions are approximate values.
Specifications may change without prior notice.

5 Location of Controls and Components

Followings are the Location of Controls and Components for SDR-H80P/PC, H90P/PC as a sample.

For other models, refer to each Operating Instructions.

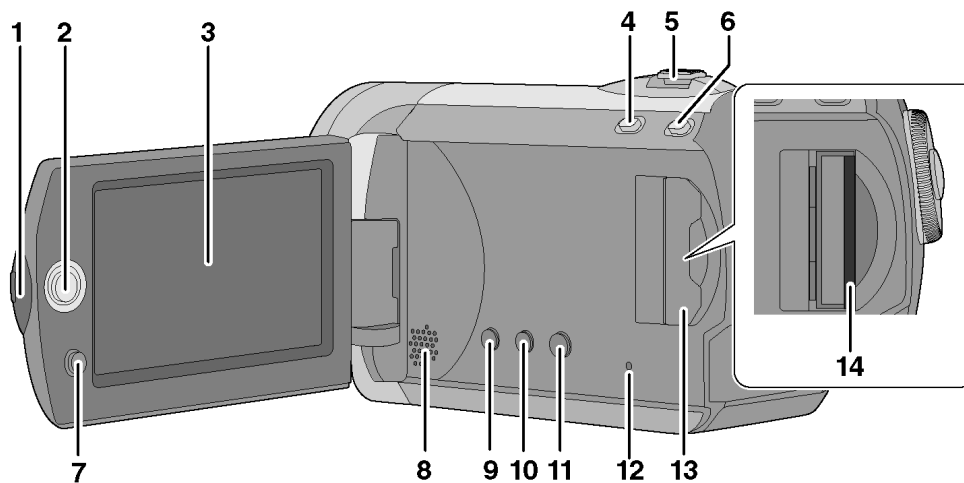

- 1 LCD monitor open
- 2 Joystick
- 3 LCD monitor

Due to limitations in LCD production technology, there may be some tiny bright or dark spots on the LCD monitor screen. However, this is not a malfunction and does not affect the recorded picture.

- 4 Web mode button [WEB MODE]
- 5 When recording: Zoom lever [W/T]
When playing back: Volume lever [- VOL +]
- 6 Intelligent auto button [iA]
- 7 Menu button [MENU]
- 8 Speaker
- 9 Delete button [⏏]
- 10 Manual button [MANUAL AF/MF]
- 11 Optical image stabilizer button [O.I.S.]
- 12 SD Card access lamp [ACCESS]
- 13 SD Card slot cover [SD CARD]
- 14 SD card slot

LCD monitor

Pull the LCD monitor out in the direction of the arrow with your fingers.

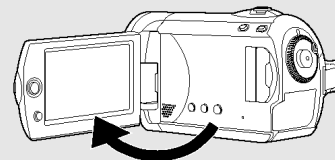

- It can open up to 90°

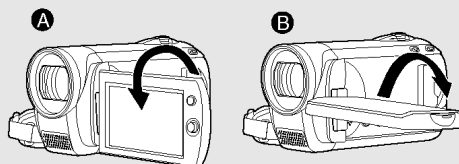

- It can rotate up to 180° **A** towards the lens or 90° **B** towards the opposite direction.
- The brightness and color level of the LCD monitor can be adjusted.

Joystick

Use the joystick to select the recording functions and playback operations, and to operate the menu screen.

Move the joystick up, down, left, or right to select a setting or scene and then press the joystick to set it.

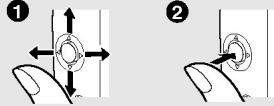

- ❶ Select by moving up, down, left or right.
- ❷ Set by pressing the center.
 - Menu screen operations
 - To select the recording functions
 - To adjust manually
 - Playback operations

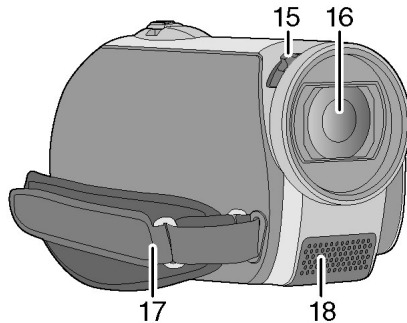

- 15 Open/close switch for the lens cover
 16 Lens
- Attach the wide conversion lens (VW-W3707H; optional) in front of the lens.
 - When using the wide conversion lens, if the magnification exceeds 20× then the image quality is degraded.
 - The tele conversion lens cannot be used.
- 17 Grip belt
 18 Microphone (built-in, stereo)

Lens cover

For the lens protection, be sure to close the lens cover when not in use.

Slide open/close switch for the lens cover.

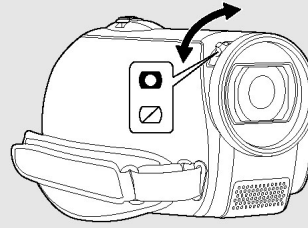

Grip belt

Adjust the belt length and the pad position.

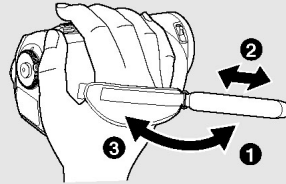

- ❶ Flip the belt.
- ❷ Adjust the length.
- ❸ Replace the belt.

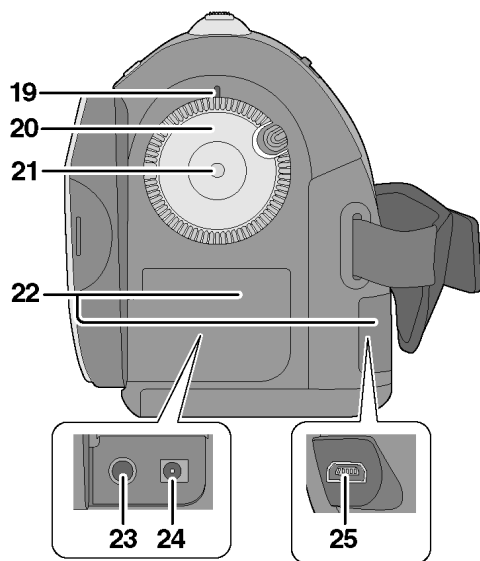

- 19 Status indicator
- 20 Mode dial
- 21 Recording start/stop button
- 22 Terminal cover
- 23 Audio-video output terminal [A/V]
- 24 DC input terminal [DC IN]
- Do not use any other AC adaptors except the supplied one.
- 25 USB terminal [↔]

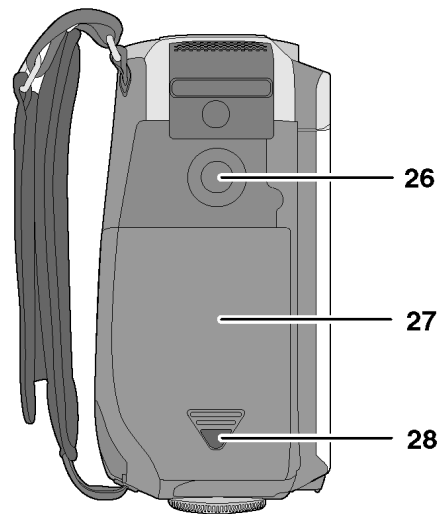

- 26 Tripod receptacle
- 27 Battery cover
- 28 Battery cover release button [PUSH/SLIDE OPEN]

Tripod receptacle

This is a hole for attaching the unit to the optional tripod.

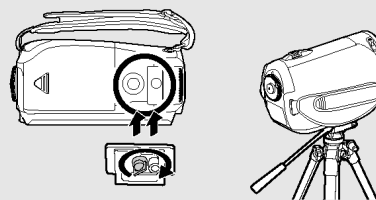

- When the tripod is used, the battery cover cannot be opened. Insert the battery before attaching this unit to the tripod.

6 Service Mode

6.1. Service Menu

When abnormal detection contents are confirmed, do the following operation. Automatic diagnosis code will be displayed. (Service Menu)

To enter the Service Menu

1. Turn the Power on and set the Mode Dial to [VIDEO RECORDING MODE].
2. Push the [OIS], [JOYSTICK CONTROL LEFT] and [iA] simultaneously for 3 seconds (with no SD Card inserted).

Note:

If a SD Card is inserted, the above operation will not work.

This operation displays the following Service Menu items.

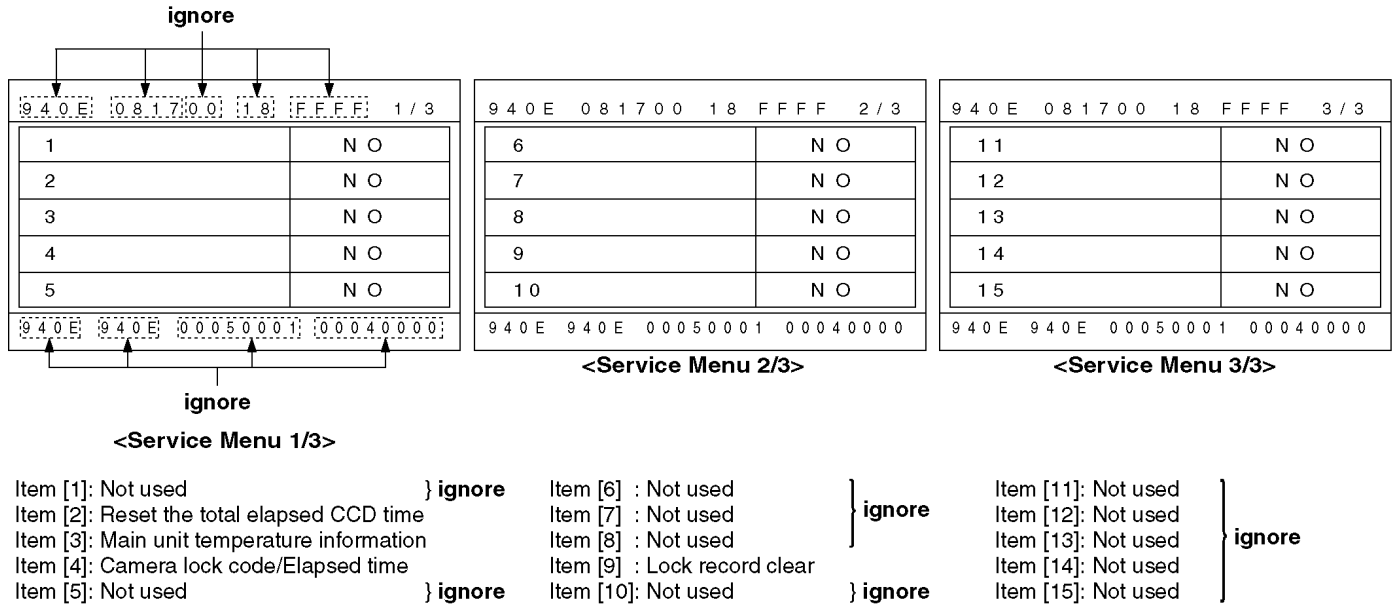

Fig. 1-1

Note:

Only perform items 2, 3, 4 and 9 in the Service Menu.

To select the Item of Service Menu

1. Press [JOYSTICK CONTROL UP/DOWN] to select item [2], [3], [4] and [9].
2. Press [JOYSTICK CONTROL RIGHT] to display [YES/NO] screen.
3. Press [JOYSTICK CONTROL UP/DOWN] to select [YES].
4. Press [JOYSTICK CONTROL CENTER] to enter.

<How to exit Service Menu>

Set Mode dial to [OFF] position.

<Item [2] screen : Reset the total elapsed CCD time>

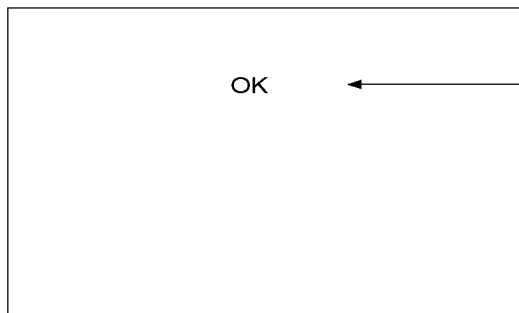

"OK" is displayed after "Reset the total elapsed CCD time" is executed.

<Item [3] screen : Main unit temperature information>

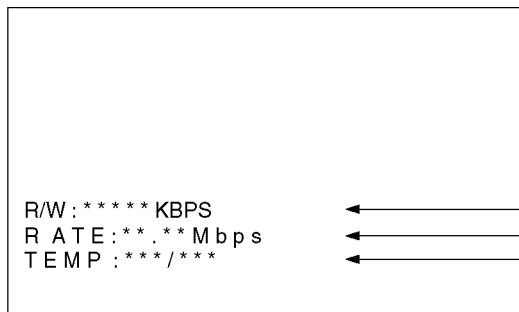

Not used
 Not used
 Main Unit temperature (current)/
 Maximum temperature after the power is turned on

Fig. 1-2

<Item [4] screen : Camera lock code/Elapsed time>

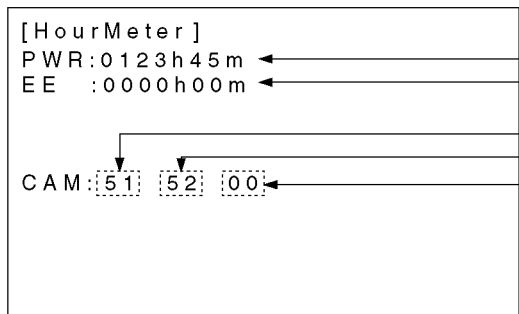

Total elapsed power on time
ignore
 Camera Error record
 The number before previous
 Previous number
 Latest number

Camera Error code record in hexadecimal

Display	Explanation of cause
00	No error
51	Focus Motor Lock
52	Zoom Motor Lock
53	OIS Drive Error
33	Communication error between CAMERA and ARM

<Item [9] screen : Lock record clear>

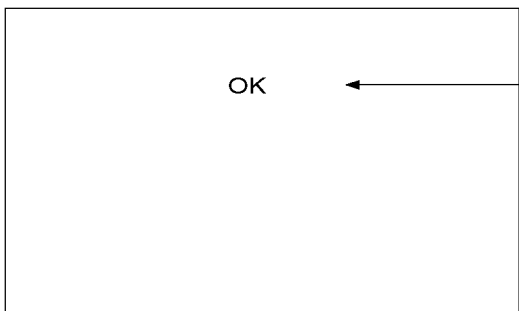

"OK" is displayed after "Lock record Clear" is executed.

Fig. 1-3

6.2. About Default Setting

The data of Menu, Mode, Card and EEPROM setting, etc. is set to the default condition in factory.

6.2.1. How to set the Default Setting

1. Turn the Power on and set the Mode Dial to [VIDEO RECORDING MODE].
2. When pressing [OIS], [JOYSTICK CONTROL RIGHT] and [iA] for more than 3 minutes simultaneously (with no SD Card inserted), the items below are set to the Default Setting.
 1. Menu, Mode, Adjusted Value
 2. Card format (when SD Card is in the SD Slot)
 3. Reset of picture files and directory number (Set the picture record file number to 1)
 4. Clear the information of Mechanism Lock
 5. Set the time setting to no-setting
3. Default Setting was set and "END" is displayed.
4. Set Mode dial to [OFF] position to exit from this mode.

7 Service Fixture & Tools

7.1. Service Tools and Equipment

Parts Name	Parts No.	Q'ty	Remarks	
PC	---	1		
AC Adaptor	---	1		
DC Cable	---	1		
AV Multi Cable	---	1		
USB Cable	---	1		
PC-Adjustment Program	---	1		
Light Box	VFK1164LBX1	1		
Infinity Lens	VFK1164TCM02	1	With Focus Chart	
Color Bar Chart	VFK1164TFCB2	1		
Gray Scale Chart	VFK1164TFGS2	1		
Color Conversion	VFK1164TFCT2	1		
Light Box	VFK1164TDVLB	1		
Color Conversion (C12)	VFK1164LBB12	1		
Color Conversion (C2)	VFK1164LBB2	1		
Color Conversion (C4)	VFK1164LBB4	1		
Color Conversion (C8)	VFK1164LBB8	1		
37mm Ring	VFK1164TAR37	1		
Infinity Lens	VFK1164TCM02	1	With Focus Chart	
Infinity Lens	RFKZ0422	1		
Tripod	VFK1164TST	1		
Tripod	RFKZ0333B	1		
Adapter for infinity Lens	RFKZ0333H	1		
Grease	LSUQ0050	1		
Plier	LSUQ0028	1		
HDD Conector Tool	LSVQ0112	1		
Pin For CCD	RFKZ0476	1		
Extension Flat Cable (6pin)	VFK1480	1	FP41 (Main)	- Front/Mic Unit
Extension Flat Cable (33pin)	VFK1950	1	FP81 (Main)	- FP8101 (LCD BL)
Extension Flat Cable (16pin)	VFK1286	1	FP61 (Sub)	- TOP/Operation Unit
Extension Flat Cable (33pin)	VFK1950	1	FP71 (Main)	- Lens Unit
Extension Flat Cable (18pin)	VFK1443	1	FP31 (Main)	- CCD Unit
Extension Flat Cable (22pin)	VFK1282	1	FP51 (Main)	- FP6301 (Rear)
Extension Flat Cable (12pin)	VFK1433	1	FP11 (Sub)	- Bottom Frame Unit
Extension Flat Cable (120pin)	VFK1877	1	B9001 (Main)	- B9002 (Sub)

8 Disassembly and Assembly Instructions

8.1. Disassembly Flow Chart

This flow chart indicates the disassembly steps the cabinet parts and P.C.B.. Unit in order to access to be serviced.
When reinstalling, perform the steps in the reverse order.

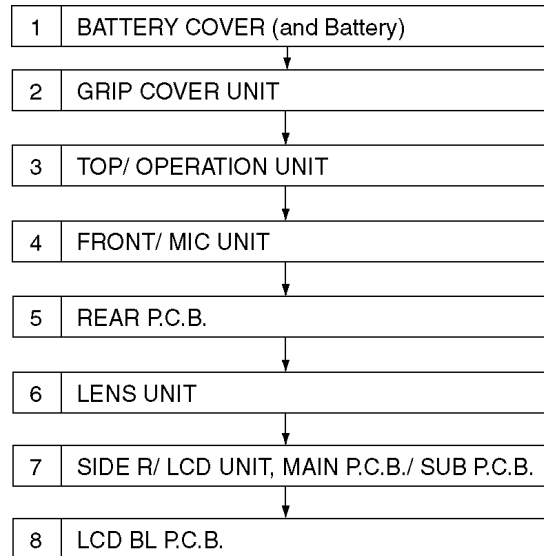

8.2. P.C.B. Layout

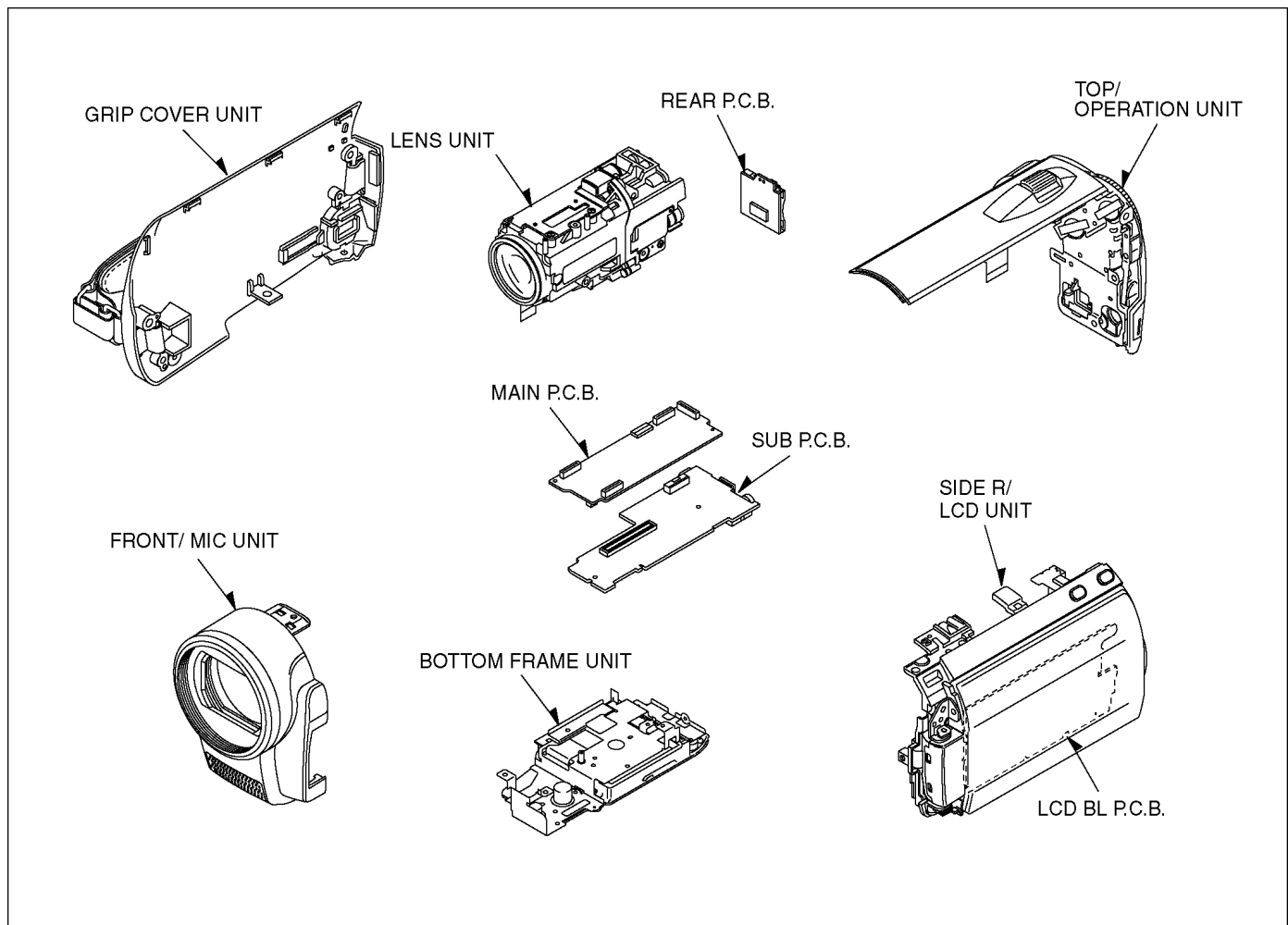

8.3. Disassembly Procedures

No.	Item / Part	Fig.	Removal (Screw, Connection, FPC & Other)
1	SD Card	Fig. D1	SD Card
2	Battery Cover Battery	Fig. D2	Battery Cover Battery
3	Side Case (R) Unit	Fig. D3	3-Screws (A) 2-Screws (B) 5-Tabs Grip cover Unit
4	Top/ Operation Unit	Fig. D4	3-Screws (C) FP61 (Unlock) 2-Tabs A 2-Tabs B Top/Operation Unit
5	Front /MIC Unit	Fig. D5	1-Screw (D) 1-Screw (E) Dowels Side Frame
6		Fig. D6	1-Screw (F) 1-Screw (G) Front/Mic unit FP41 (Pull out)
7	Rear P.C.B. Unit	Fig. D7	1 Screw (H) Rear P.C.B. Dowel FP51 (Pull out)
8	Lens Unit	Fig. D8	1 Screw (I) 2-Projections FP71 (Unlock) FP31 (Pull out) Lens Unit
9	Side R / LCD Unit, /Main / Sub P.C.B.	Fig. D9	2-Screws (J) FP81(Unlock) P91 (Pull out) Side R/LCD Unit Angle/P.C.B. Unit
10	Main / Sub P.C.B.	Fig. D10	2 Screws (L) 2 Screws (M) Main P.C.B. Sub P.C.B. PCB Angle 2-Projections FP11 (Unlock) B9001 (Unlock) B9002 (Unlock)
11	LCD BL Unit	Fig. D11	2 Screws (K) Side R /Speaker Unit 8 Locking Tabs FP8101 (Pull out) LCD Case A Unit LCD Case B Unit
12		Fig. D12	2 Screws (O) Menu Selector Unit Deco Piece FP8104 (Pull out) LCD BL P.C.B.
13		Fig. D13	LCD BL P.C.B. FP8103 (Pull out) 8 Locking Tabs LCD BL P.C.B.

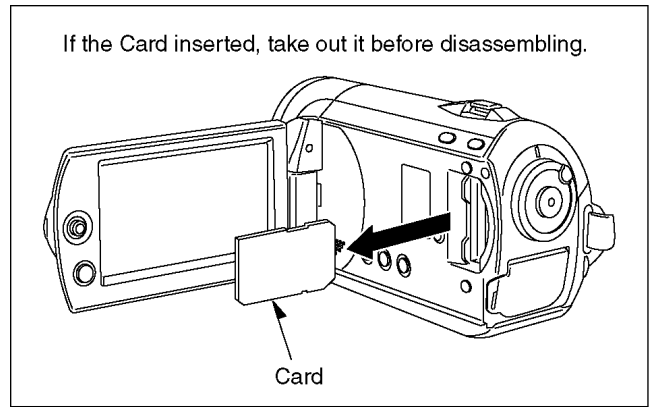

Fig. D1

1) How to Remove

If a battery is set, remove battery.

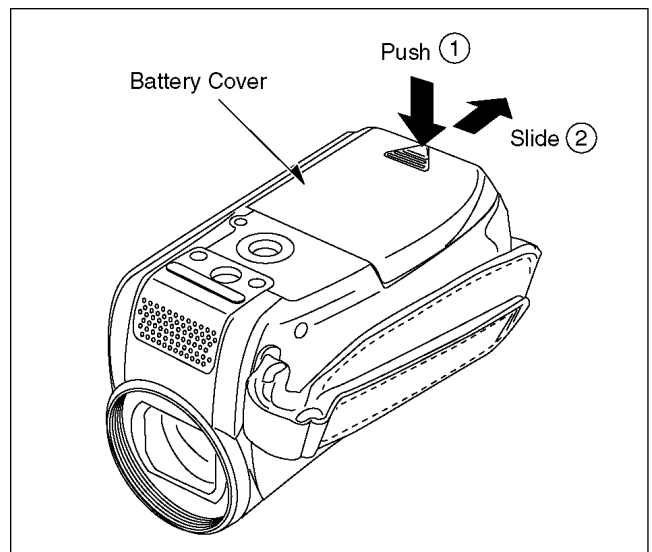

Fig. D2

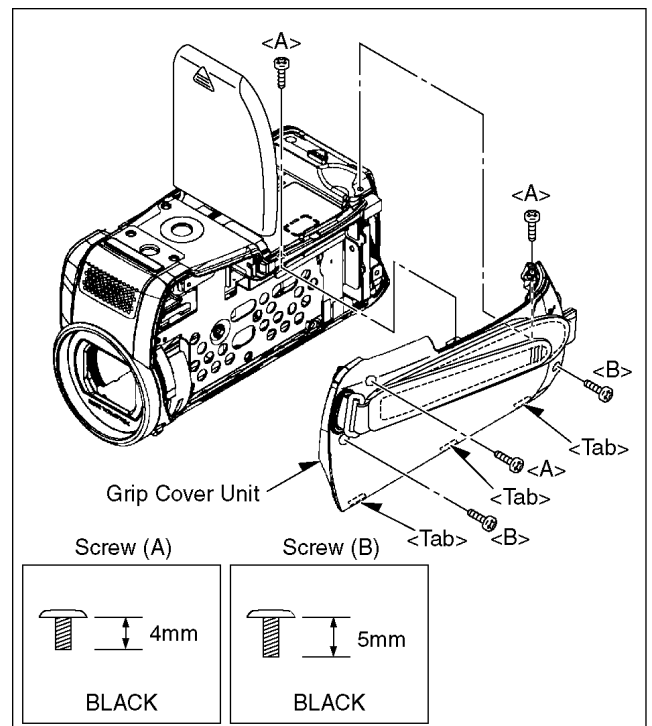

Fig. D3

1) How to Remove

1. Slide Top/ Operation unit by approx. 3mm to unlock Tabs A not to damage FPC
2. Unlock Tabs B.
3. Unlock FP61.

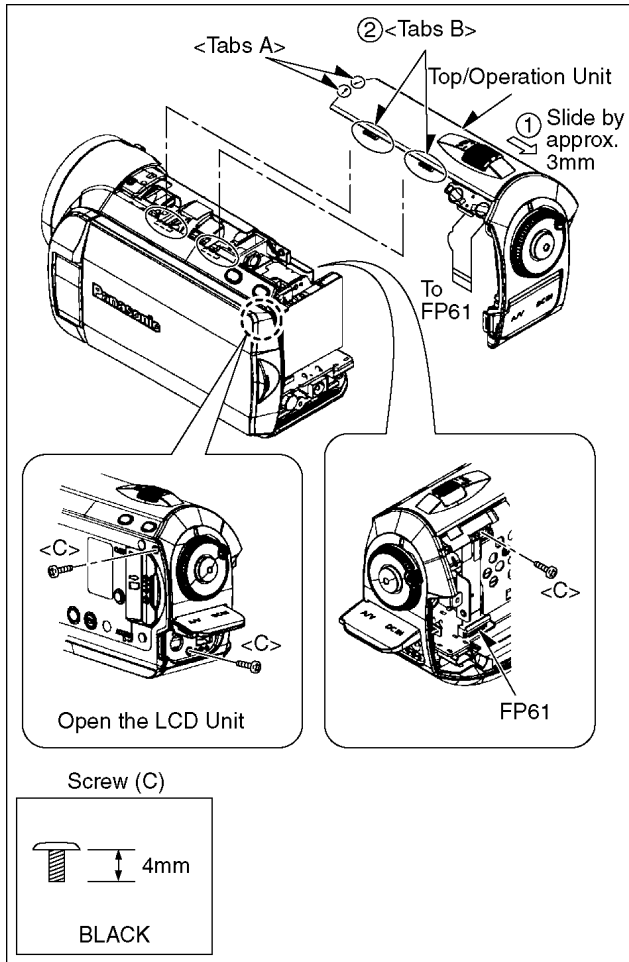

Fig. D4

How to remove

1. Unlock the locking portions from the Dowels.

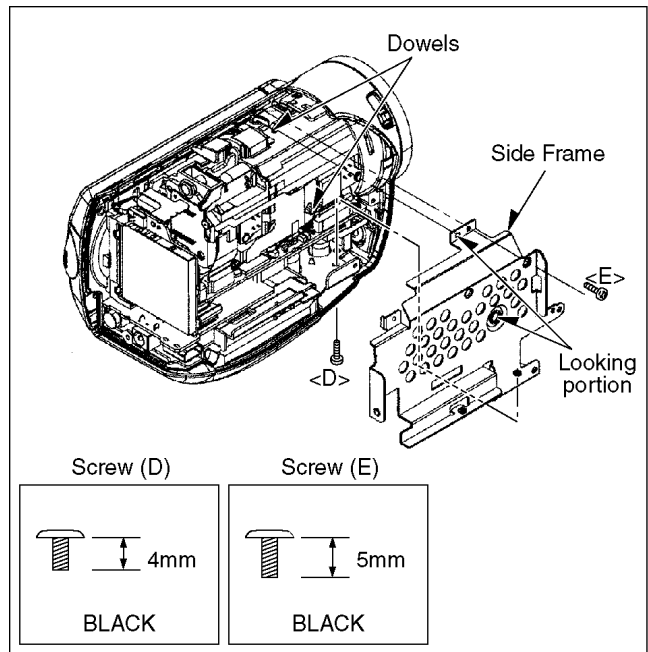

Fig. D5

How to remove

1. Pull out FPC from FP41.
2. Remove lower side of Front/ Mic unit first, and remove it from the Tab.

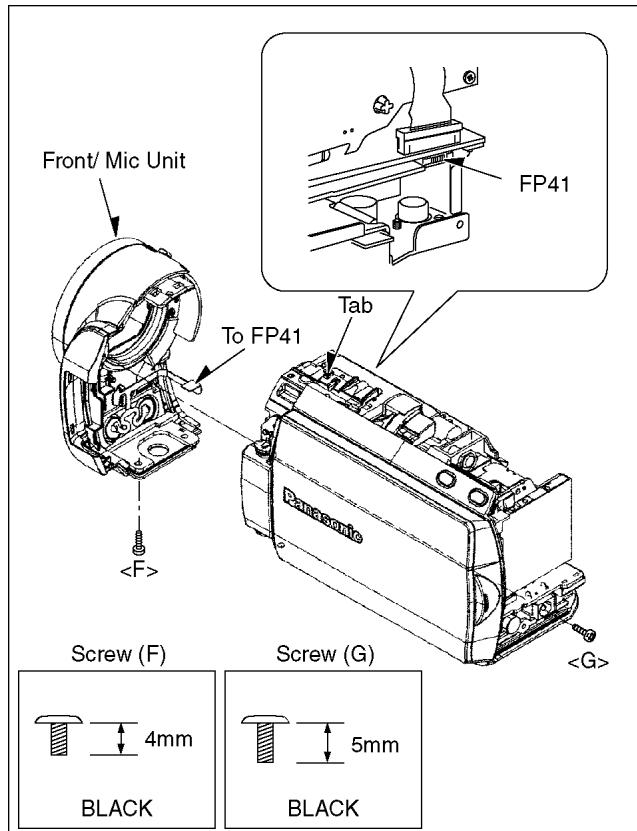

Fig. D6

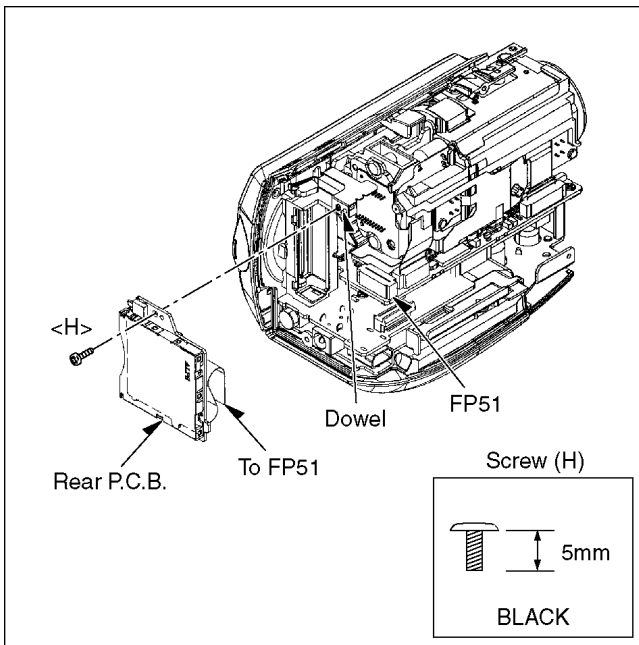

Fig. D7

How to remove

1. Remove Projections from Side R/ LCD Unit.

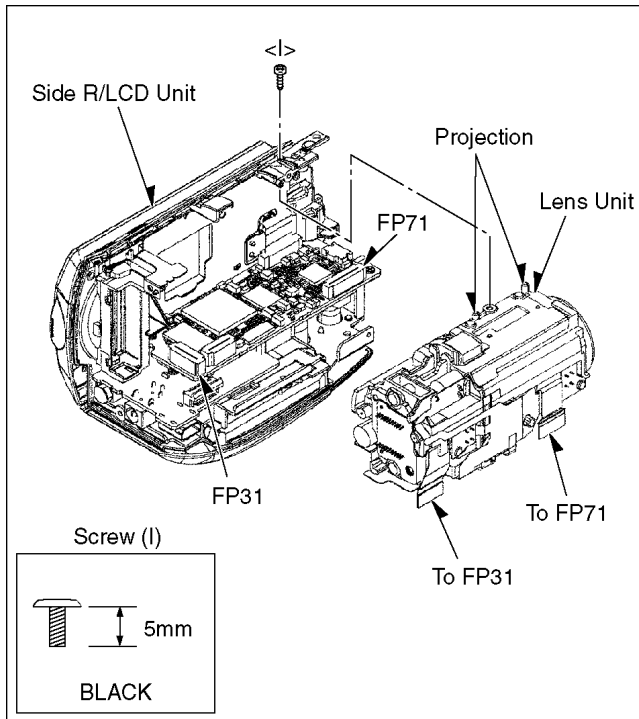

Fig. D8

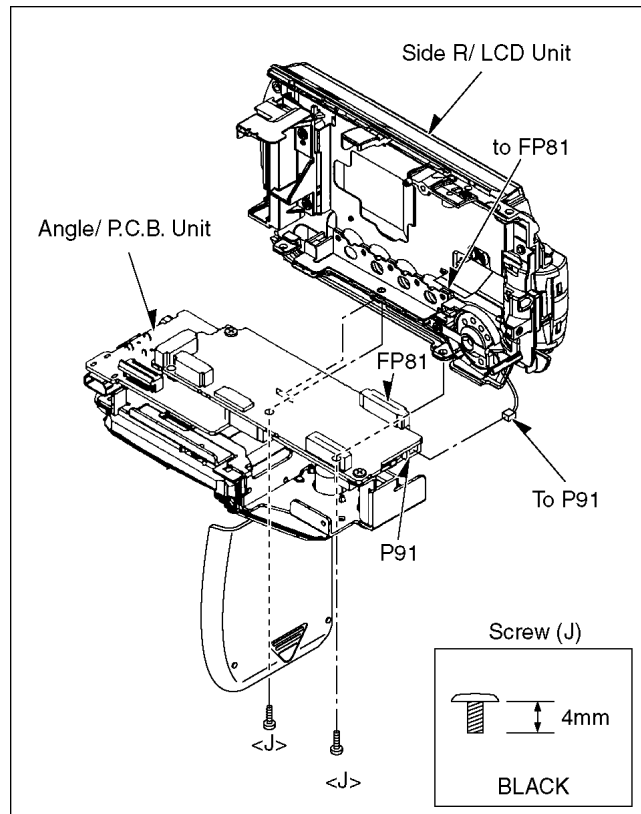

Fig. D9

How to remove

1. Remove 2 screws (L).
2. Unlock Connector B9001 from B9002 to remove Main P.C.B.

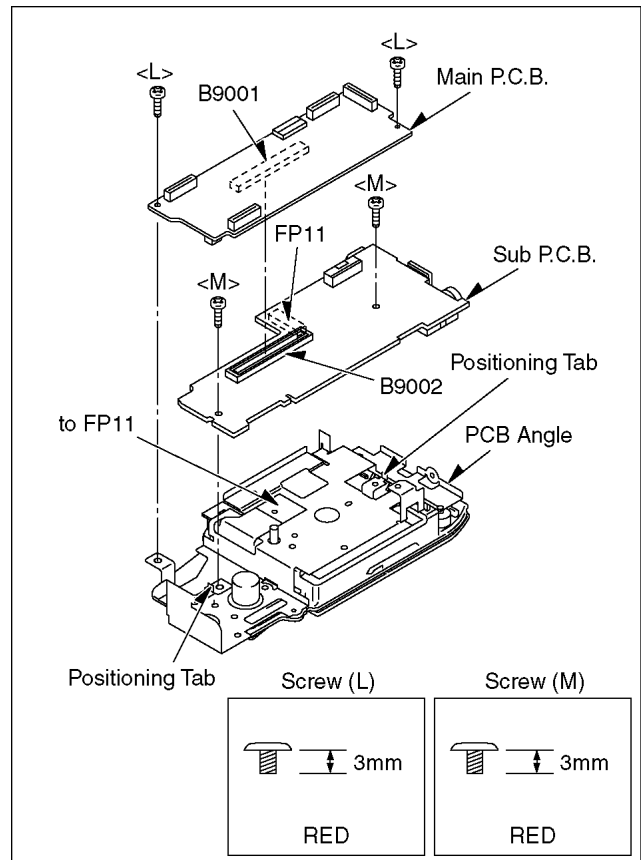

Fig. D10

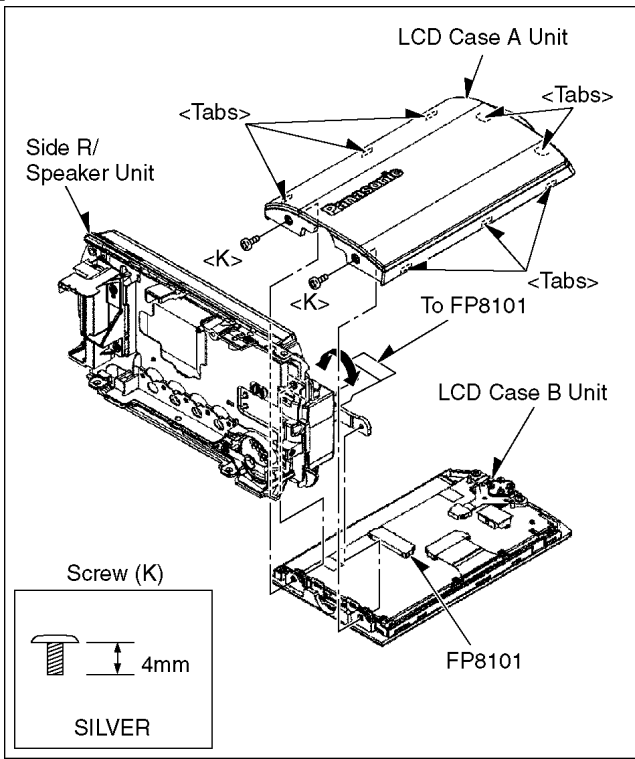

Fig. D11

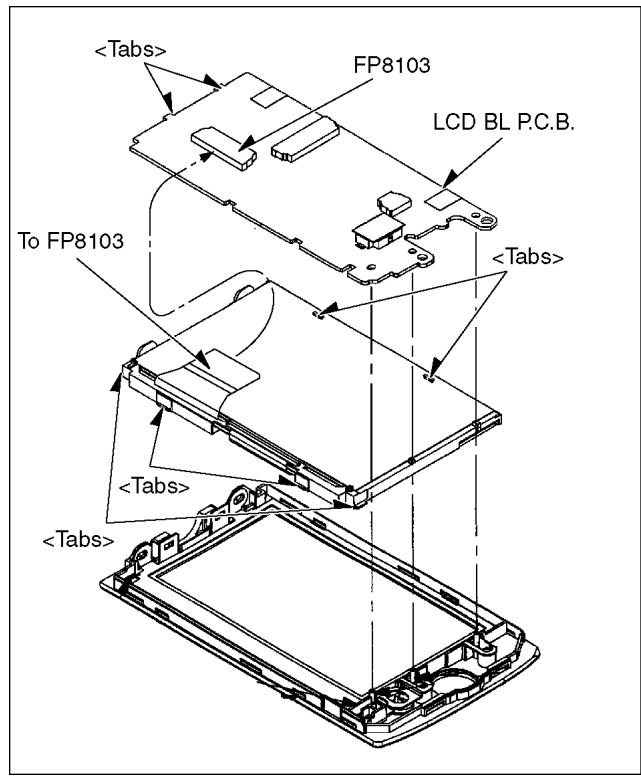

Fig. D13

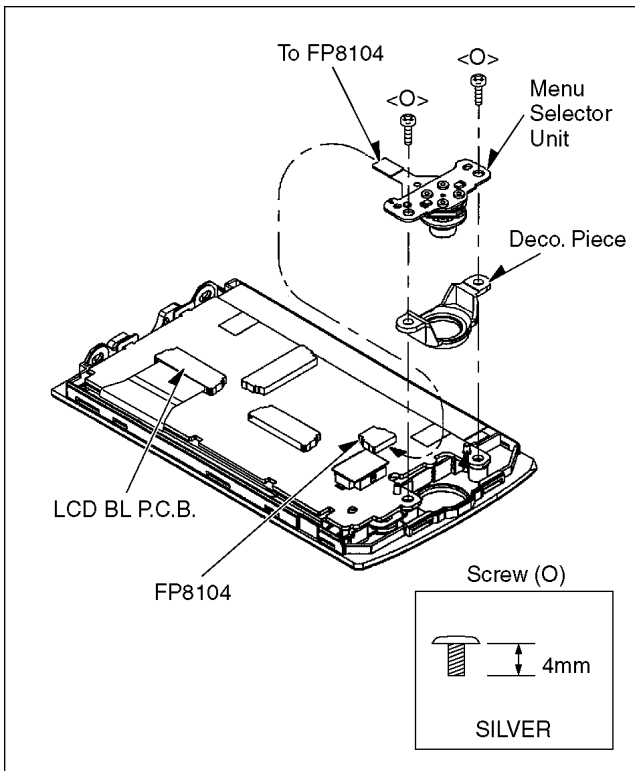

Fig. D12

8.4. Disassembly Procedures of Camera Lens Unit

The following flowchart describes order or steps for removing the Camera lens unit and certain printed circuit boards in order to make access to the item needing service.

To reassemble the unit follow the steps in reverse order.

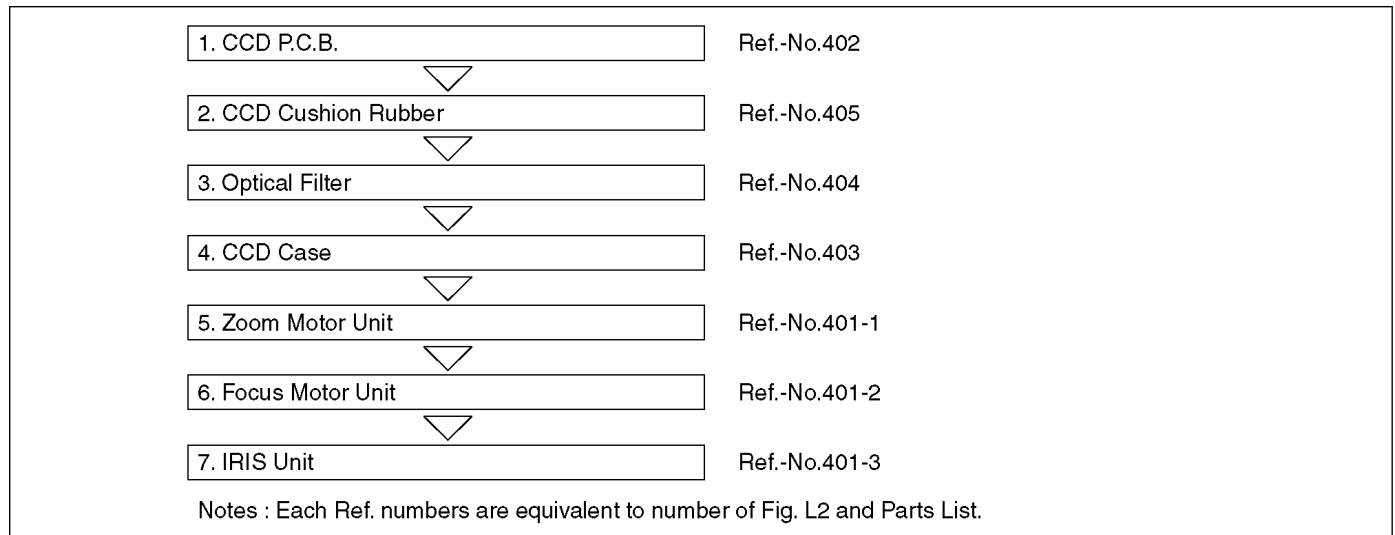

Fig. L1

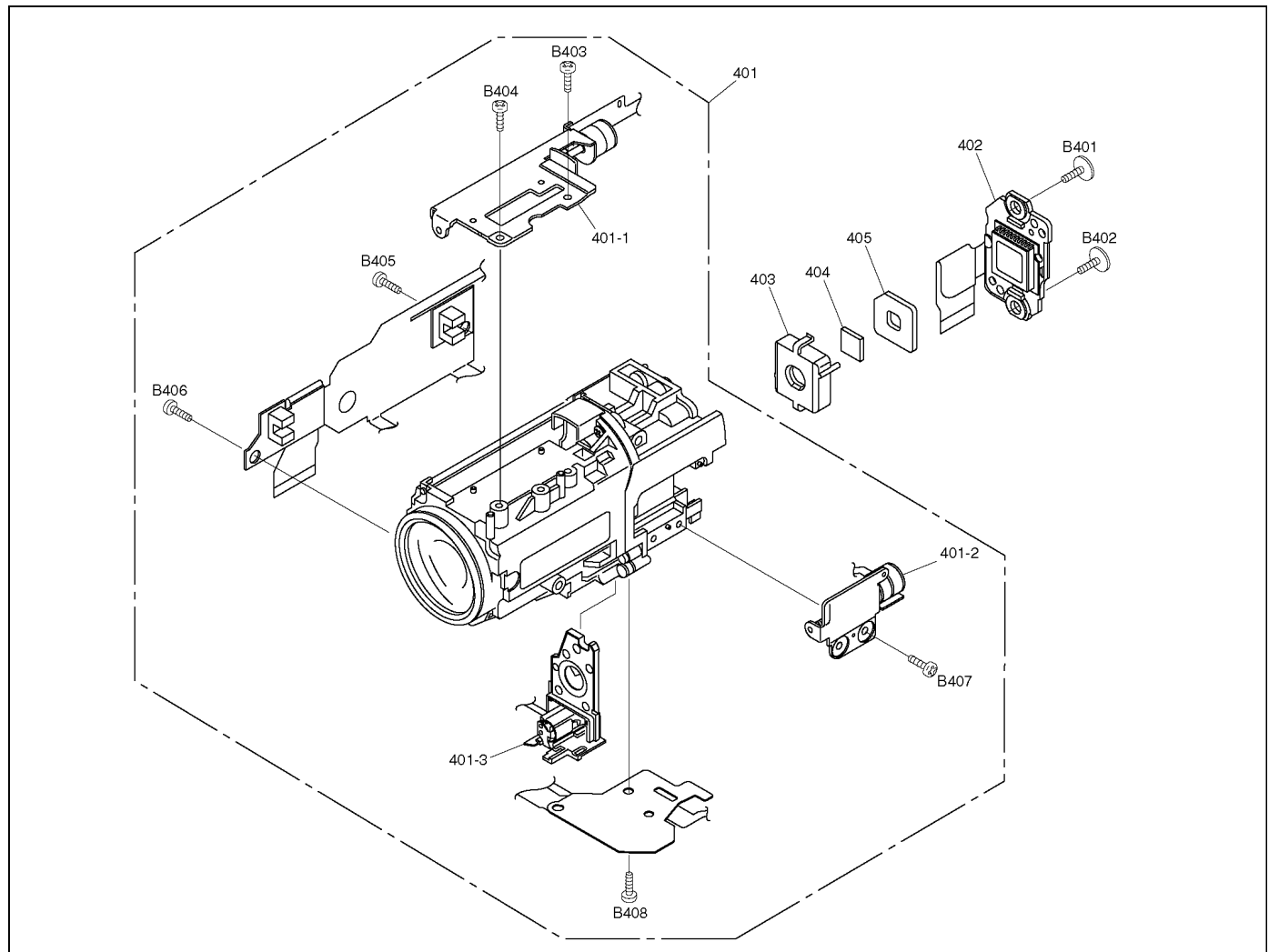

Fig. L2

9 Measurements and Adjustments

9.1. EEPROM Data for spare parts of the SUB P.C.B.

After replacing the SUB P.C.B., be sure to achieve adjustment.

As for Adjustment condition/procedure, consult the "Adjustment Manual" which is available in Adjustment software.

The Adjustment software is available at "TSN Website", therefore, access to "TSN Website" at "Support Information from NWBG/VDBG-PAVC".

9.2. Service Positions

9.2.1. List of the extension cables

Use the following extension cables when checking or adjusting individual circuit boards except module Parts (Main P.C.B. and Sub P.C.B.).

Ref.	Part No.	Pin	Part Name	Connection			Q'ty
1	VFK1480	6	Flat Cable	FP41	(Main)	- Front/Mic Unit	1
2	VFK1950	33	Flat Cable	FP81	(Main)	- FP8101 (LCD BL)	1
3	VFK1950	33	Flat Cable	FP71	(Main)	- Lens Unit	1
4	VFK1443	18	Flat Cable	FP31	(Main)	- CCD Unit	1
5	VFK1282	22	Flat Cable	FP51	(Main)	- FP6301 (Rear)	1
6	VFK1286	16	Flat Cable	FP61	(Sub)	- Top/Operation Unit	1
7	VFK1433	12	Flat Cable	FP11	(Sub)	- Bottom Frame Unit	1

9.2.2. Checking and repairing individual circuit boards except module parts (Main P.C.B. and Sub P.C.B.)

How to use extension cables.

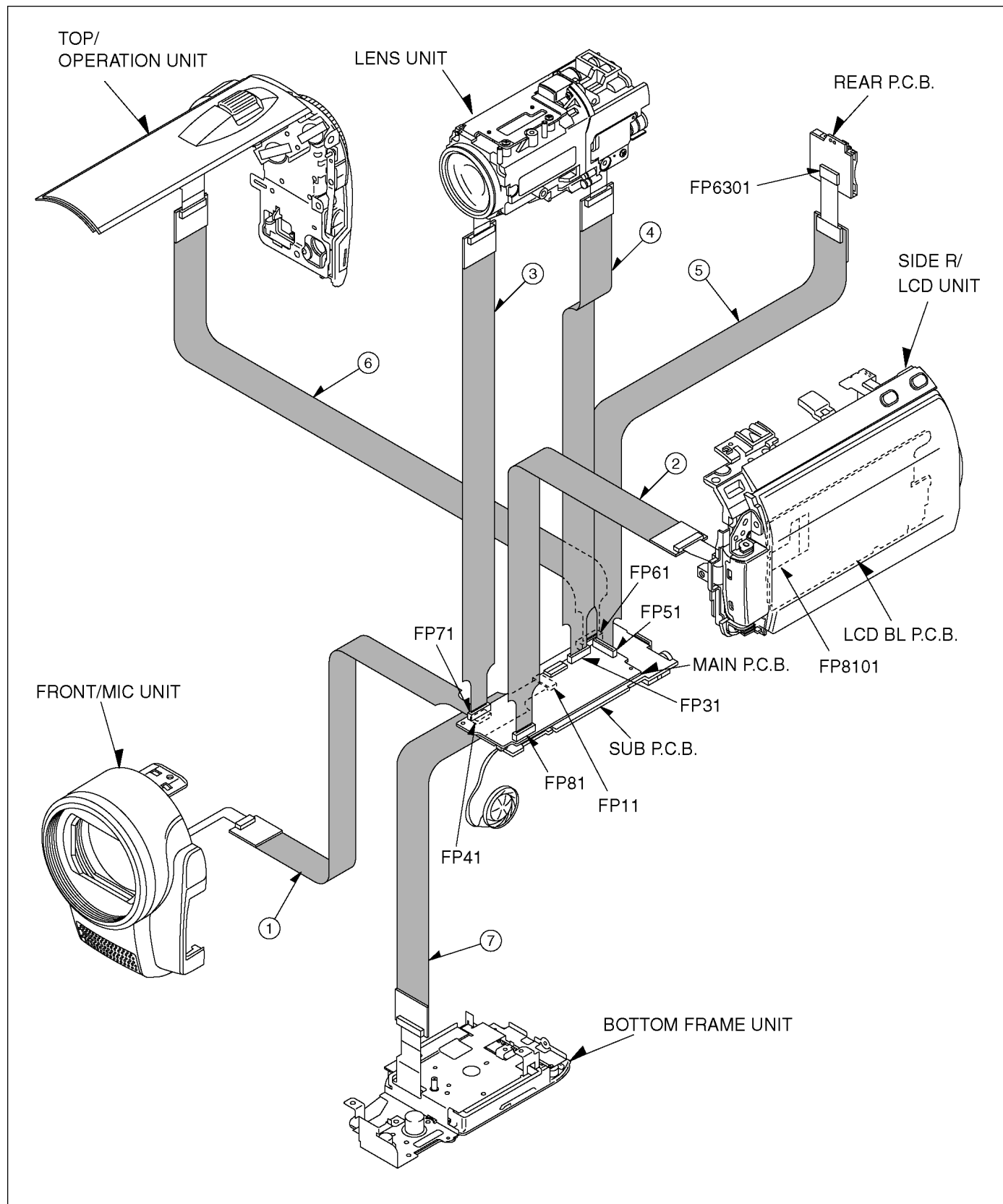

9.3. Location for Connectors of the Main P.C.B. and Sub P.C.B.

9.3.1. Main P.C.B.

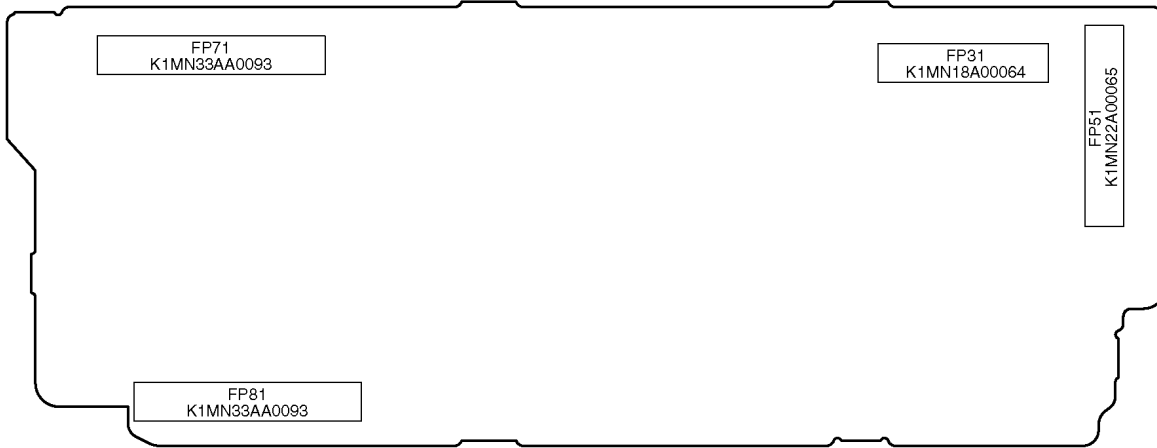

(COMPONENT SIDE)

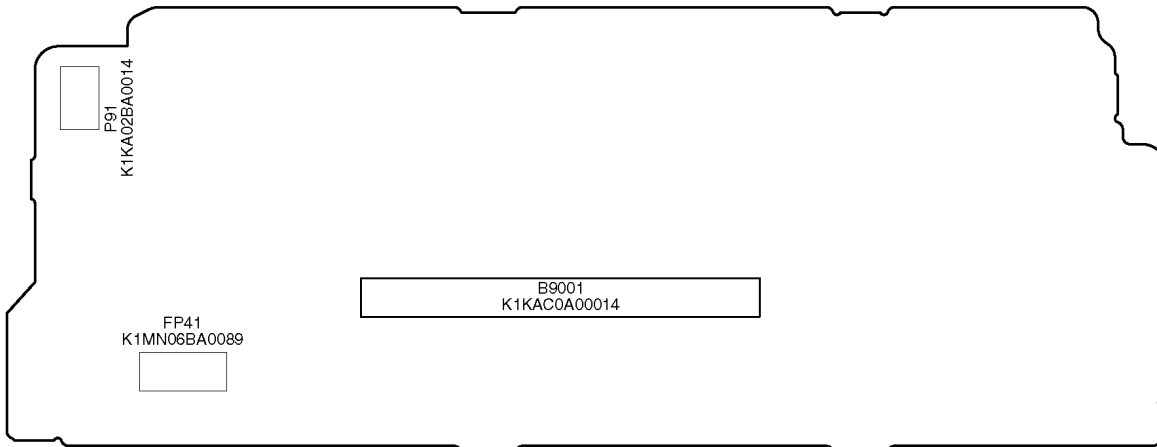

(FOIL SIDE)

9.3.2. Sub P.C.B.

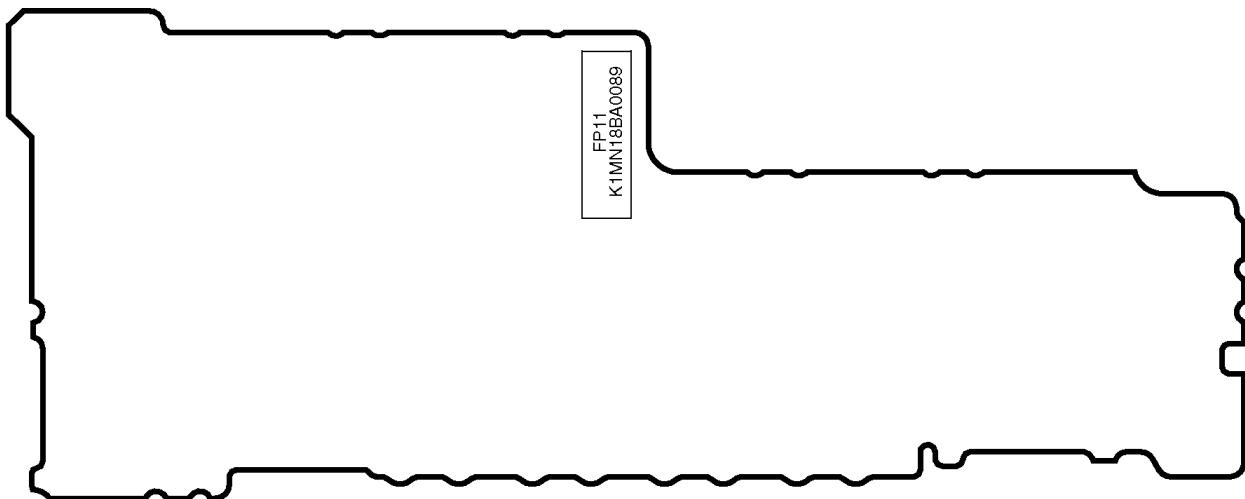

(COMPONENT SIDE)

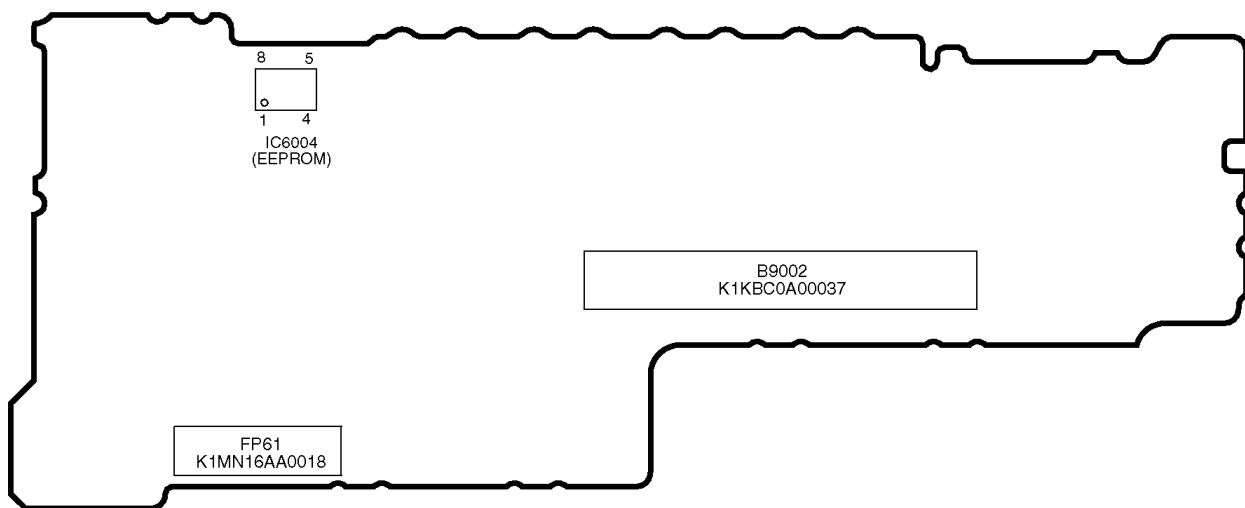

(FOIL SIDE)

9.4. Electrical Adjustment Procedures

9.4.1. Initial Guideline

The table below shows which adjustments are necessary according to the unit parts and individual parts to be replaced. Make sure to perform these adjustments shown below as necessary.

Adjustment Item		Replacement Parts											
		Sub P.C.B.	Main P.C.B.	IC302 (CAMERA SIGNAL PROCESS)	IC701 (FOCUS/ZOOM MOTOR DRIVE & OIS/IRIS/HALL AMP CONTROL)	IC3001 (CAMERA DIGITAL SIGNAL PROCESS/SHUFFLING)	IC3301 (VIDEO/AUDIO SIGNAL PROCESS)	IC6001 (SYSTEM MICROCONTROLLER)	IC6004 (EEPROM)	CCD P.C.B.	Lens Unit	IRIS Unit	CCD Unit
Camera	CAM hall amplifier and Iris PWM	<input type="radio"/>	<input type="radio"/>	<input type="radio"/>	<input type="radio"/>	<input type="radio"/>	<input type="radio"/>	<input type="radio"/>	<input type="radio"/>	<input type="radio"/>	<input type="radio"/>	<input type="radio"/>	<input type="radio"/>
	CAM OIS Hole amplifier	<input type="radio"/>	<input type="radio"/>	<input type="radio"/>	<input type="radio"/>	<input type="radio"/>	<input type="radio"/>	<input type="radio"/>	<input type="radio"/>	<input type="radio"/>	<input type="radio"/>	<input type="radio"/>	<input type="radio"/>
	CAM Tracking and De-focus	<input type="radio"/>	<input type="radio"/>	<input type="radio"/>	<input type="radio"/>	<input type="radio"/>	<input type="radio"/>	<input type="radio"/>	<input type="radio"/>	<input type="radio"/>	<input type="radio"/>	<input type="radio"/>	<input type="radio"/>
	CAM WB rough	<input type="radio"/>	<input type="radio"/>	<input type="radio"/>	<input type="radio"/>	<input type="radio"/>	<input type="radio"/>	<input type="radio"/>	<input type="radio"/>	<input type="radio"/>	<input type="radio"/>	<input type="radio"/>	<input type="radio"/>
	CAM AWB 3100	<input type="radio"/>	<input type="radio"/>	<input type="radio"/>	<input type="radio"/>	<input type="radio"/>	<input type="radio"/>	<input type="radio"/>	<input type="radio"/>	<input type="radio"/>	<input type="radio"/>	<input type="radio"/>	<input type="radio"/>
	CAM AWB 5100	<input type="radio"/>	<input type="radio"/>	<input type="radio"/>	<input type="radio"/>	<input type="radio"/>	<input type="radio"/>	<input type="radio"/>	<input type="radio"/>	<input type="radio"/>	<input type="radio"/>	<input type="radio"/>	<input type="radio"/>
	CAM Revision CCD scratch	<input type="radio"/>	<input type="radio"/>	<input type="radio"/>	<input type="radio"/>	<input type="radio"/>	<input type="radio"/>	<input type="radio"/>	<input type="radio"/>	<input type="radio"/>	<input type="radio"/>	<input type="radio"/>	<input type="radio"/>
Video	VIDEO Luminance level	<input type="radio"/>	<input type="radio"/>	<input type="radio"/>	<input type="radio"/>	<input type="radio"/>	<input type="radio"/>	<input type="radio"/>	<input type="radio"/>	<input type="radio"/>	<input type="radio"/>	<input type="radio"/>	

Note : : Adjustment Item

9.4.2. Set-up manual for SD Card/Hard Disk Video Camera.

1. Installation of USB-SERIAL Driver

Execute the "Setup.exe" file in "Com Mass" folder by double clicking to install the USB-SERIAL driver.

2. Set-Up

- a. Remove the SD card from this unit.
- b. To enter the PC connection (COM) mode, push the [OIS] button, [iA] button and [JOYSTICK CONTROL UP] simultaneously for 3 seconds without connecting the USB Cable.

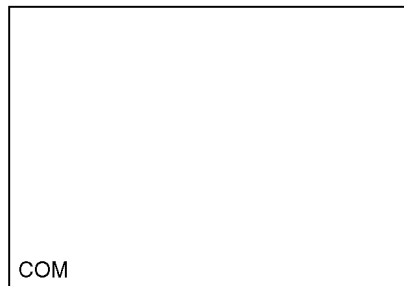

<LCD Monitor> at recording modes

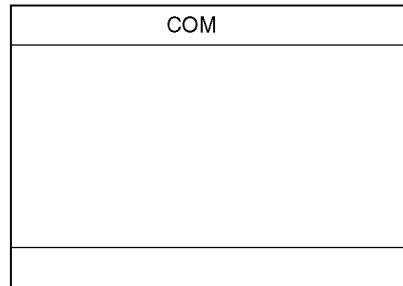

<LCD Monitor> at playback modes

c. Connect the PC and SD Card/Hard Disk Video Camera as shown in Fig. E1 and E2.

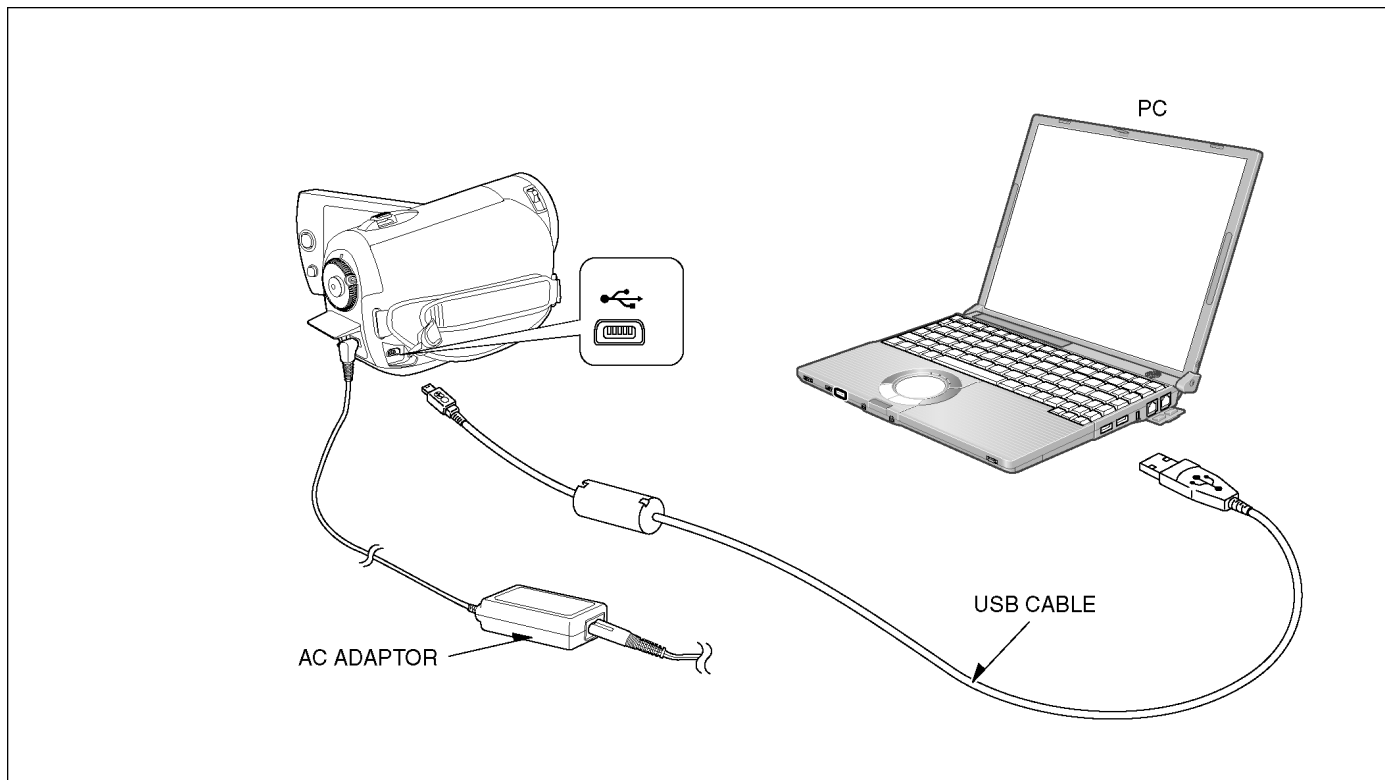

Fig. E1

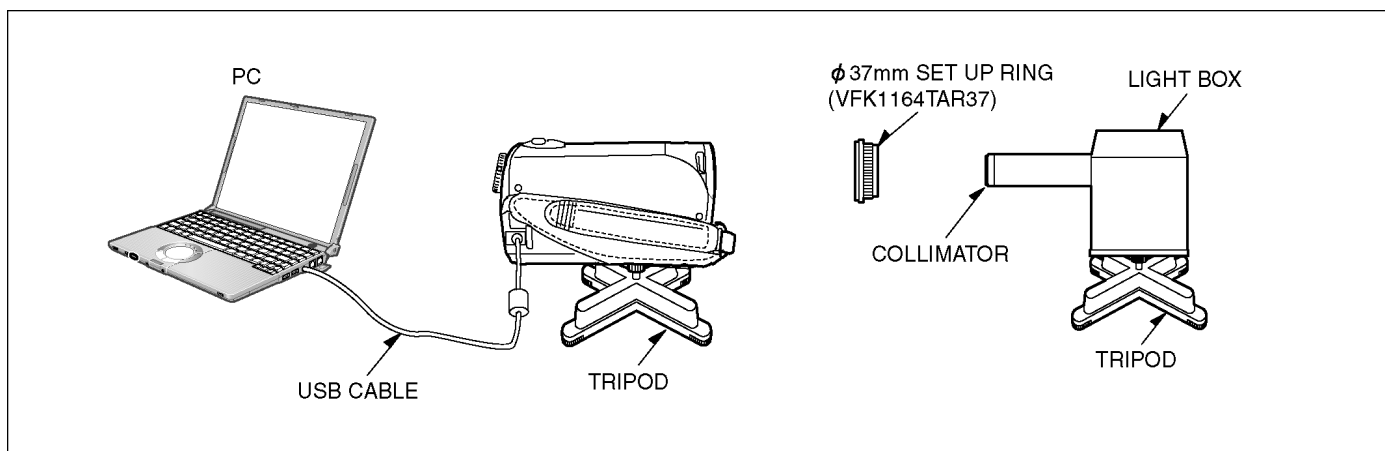

Fig. E2 Rough image of set-up connection

9.4.3. Set up of PC-EVR Adjustment Program

1. Turn on the PC and install the PC-EVR Adjustment Program into the PC.
2. Execute the "khd2009.exe" file by double clicking to start up the PC-EVR Adjustment Program.

The main menu will be displayed.

3. Select the appropriate model.
4. Confirm the camcorder is in PC connection (COM) mode (refer to step 2 on item 9.4.2.). Then click "Start".

Note:

When the camcorder does not power on, turn the power on with forced power on function.

<How to turn the power on with forced power on function
>

Push and hold the [OIS] and [JOYSTICK CONTROL RIGHT], then set [MODE DIAL] to ON until the power is turned on.

- ① Select the appropriate model.

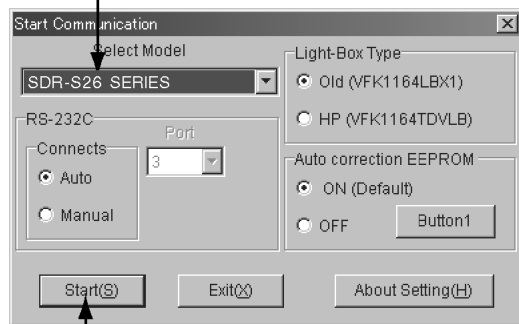

- ② Click to start.

Fig. E2-1

5. When the communication is complete, the dialog will appear.

Click "Yes" and "Save" to save the EEPROM data.

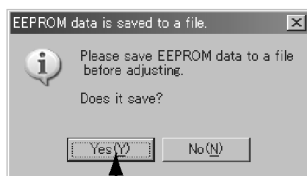

- ③ Click.

Fig. E2-2

6. When EEPROM data has been saved, the menu will appear.

To perform each adjustment, display the adjustment menu by selecting from "Camera Adjust" or "Video Adjust" and select each adjustment item.

- ④ Select the desired menu.

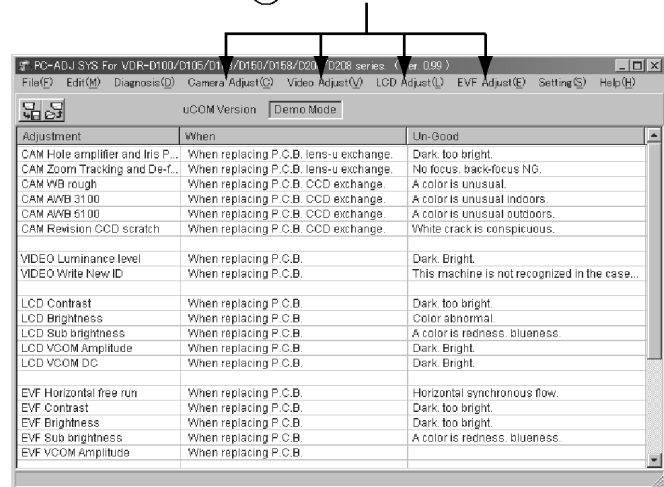

Fig. E2-3

Note:

The adjusted data is stored in the EEPROM IC after each adjustment.

7. After adjustment, to close the software, select "Exit" in the File menu or close the window.

- ⑤ Select "Exit" or close the window.

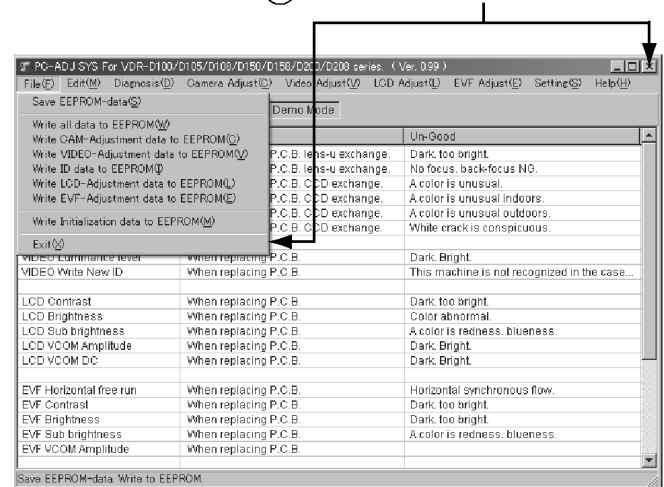

Fig. E2-4

8. To release the PC connection (COM) mode, push the [OIS], [iA] and [JOYSTICK CONTROL UP] simultaneously for 3 seconds with the USB Cable disconnected.

9.4.4. How to confirm "OneNAND-Flash ROM Error"

If there is a problem with Flash ROM (IC3203), the unit does not turn the power on.

(Problem: When the power SW is turned on, the power LED lights for 3 seconds and goes out. The power can not be turned on again.)

If this problem occurs, check if the Flash ROM (IC3203) has a problem in the following procedure.

1. Start PC-EVR Adjustment Program.

Refer to "9.4.3. Set up of PC-EVR Adjustment Program" and start PC-EVR Adjustment Program.

2. Select the "Diagnosis"

① Select the "Diagnosis"

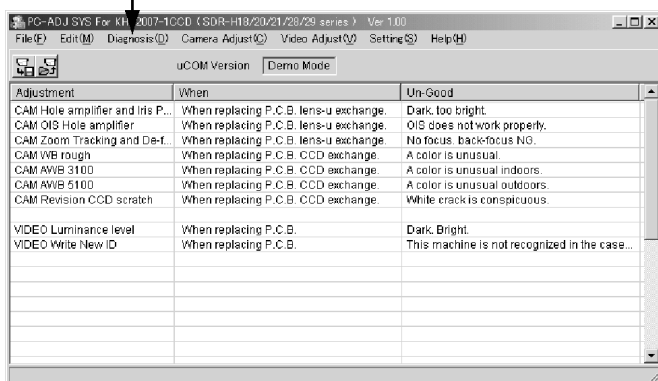

Fig. E2-5

3. Select the "Lock Info"

② Select the "Lock Info"

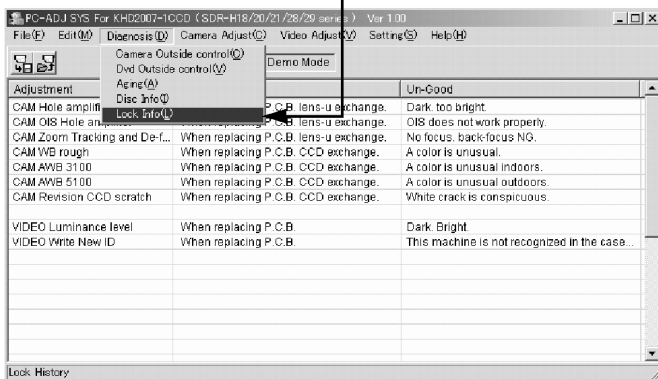

Fig. E2-6

4. Confirm the OneNAND-Flash ROM Error information.

OneNAND-Flash ROM Error information
 No Error : Flash ROM (IC3203) is normal.
 Fatal Error : Flash ROM (IC3203) is defective.

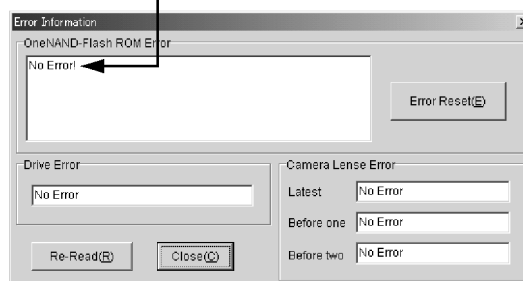

Fig. E2-7

5. If "Fatal Error" is displayed, Flash ROM (IC3203) is defective. Replace Main P.C.B.

Note:

This error information is recorded on EEPROM.

Click "Error Reset" to clear the error information after replacing Flash ROM (IC3203).

③ Click the "Error Reset"

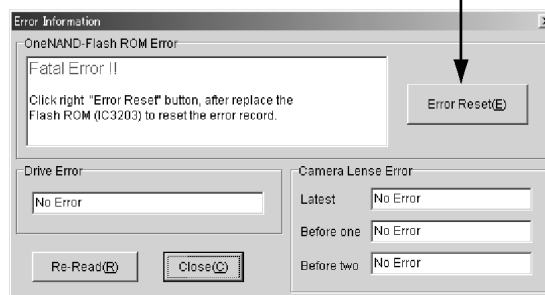

Fig. E2-8

10 Maintenance

10.1. Cleaning Lens and LCD Panel

Do not touch the surface of the lens and LCD Panel with your hand.

When cleaning the lens, use air-Blower to blow off the dust.

When cleaning the LCD Panel, dampen the lens cleaning paper with lens cleaner, and the gently wipe the their surface.

Note:

A lens cleaning paper and lens cleaner are available at local camera shops and market place.

11 Schematic Diagrams

11.1. OVERALL SCHEMATIC DIAGRAM

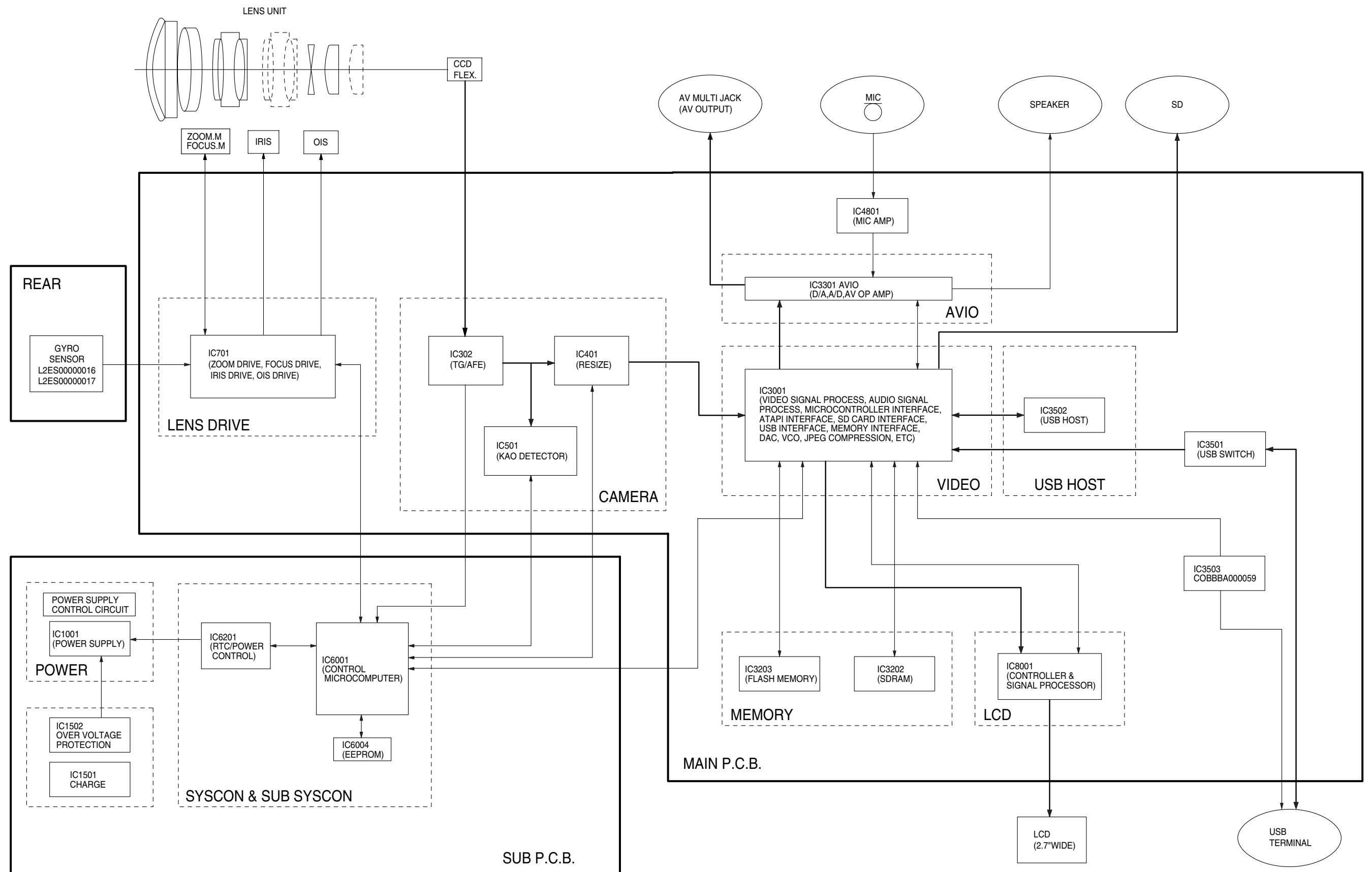

SDR-S26
OVERALL SCHEMATIC DIAGRAM

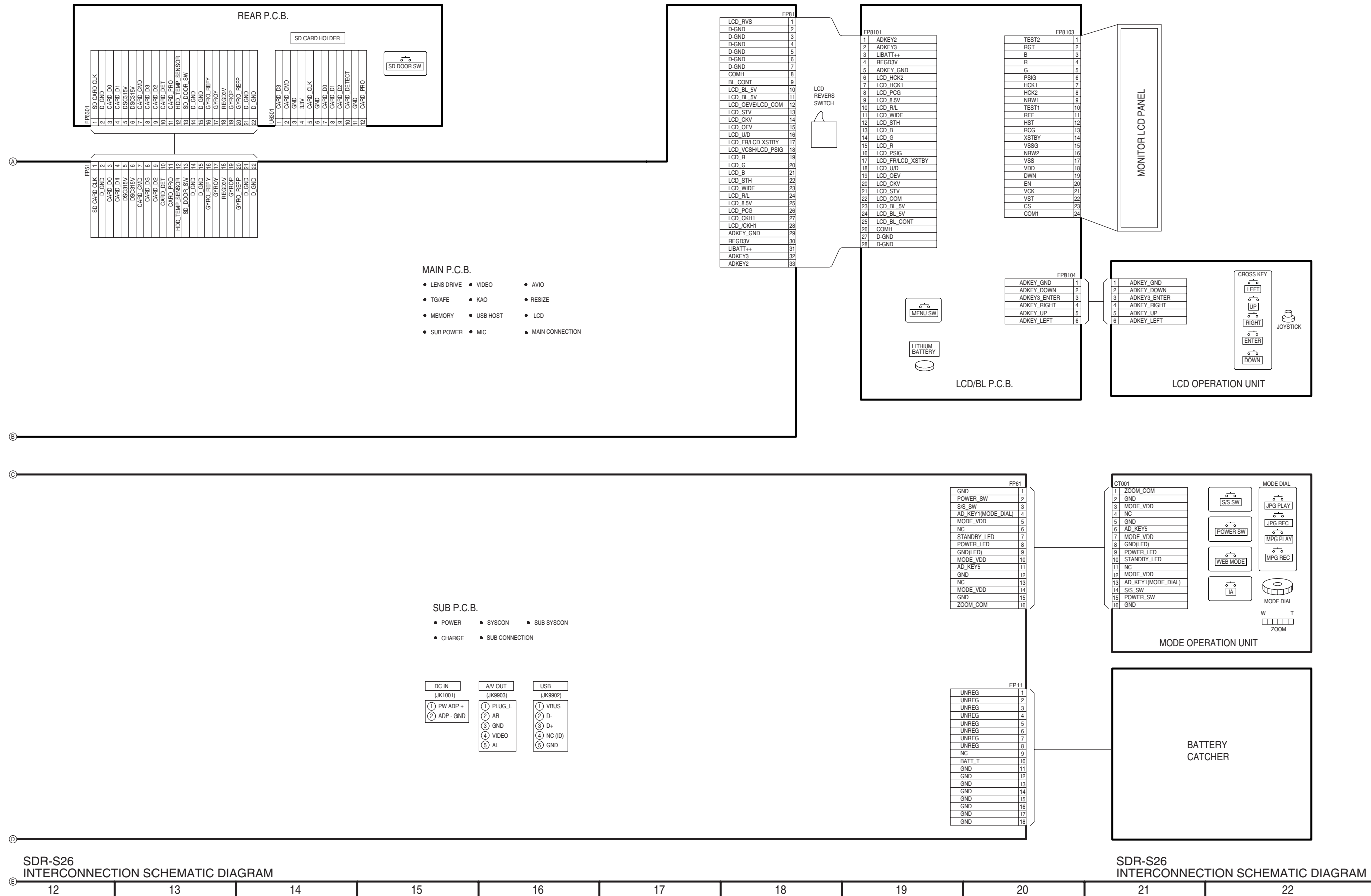

SDR-S26 INTERCONNECTION SCHEMATIC DIAGRAM

SDR-S26P INTERCONNECTION SCHEMATIC DIAGRAM

11.3. REAR SCHEMATIC DIAGRAM

(REAR P.C.B.)

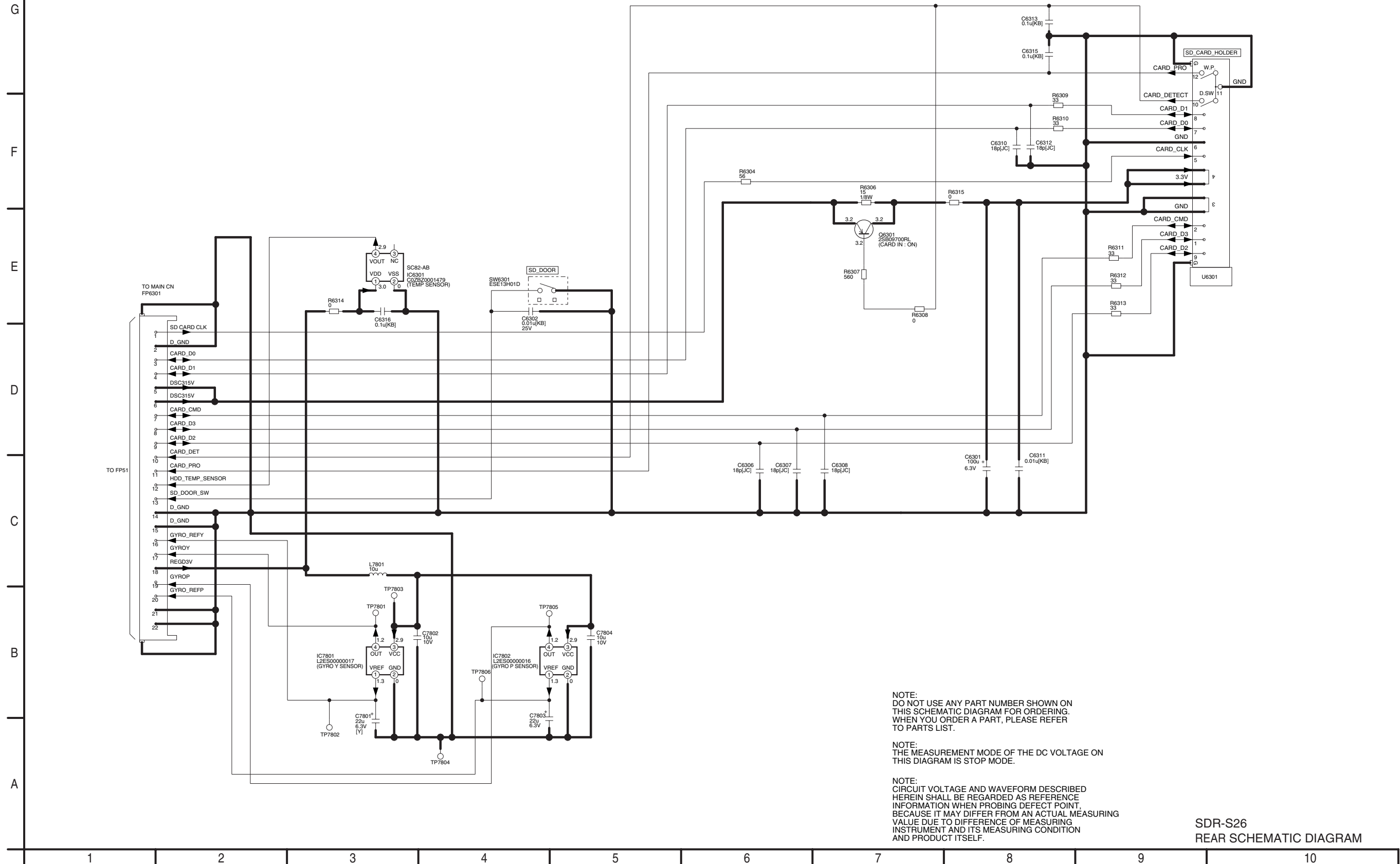

NOTE:
DO NOT USE ANY PART NUMBER SHOWN ON THIS SCHEMATIC DIAGRAM FOR ORDERING. WHEN YOU ORDER A PART, PLEASE REFER TO PARTS LIST.

NOTE:
THE MEASUREMENT MODE OF THE DC VOLTAGE ON THIS DIAGRAM IS STOP MODE.

NOTE:
CIRCUIT VOLTAGE AND WAVEFORM DESCRIBED HEREIN SHALL BE REGARDED AS REFERENCE INFORMATION WHEN PROBING DEFECT POINT. BECAUSE IT MAY DIFFER FROM AN ACTUAL MEASURING VALUE DUE TO DIFFERENCE OF MEASURING INSTRUMENT AND ITS MEASURING CONDITION AND PRODUCT ITSELF.

SDR-S26
REAR SCHEMATIC DIAGRAM

11.4. LCD BL SCHEMATIC DIAGRAM

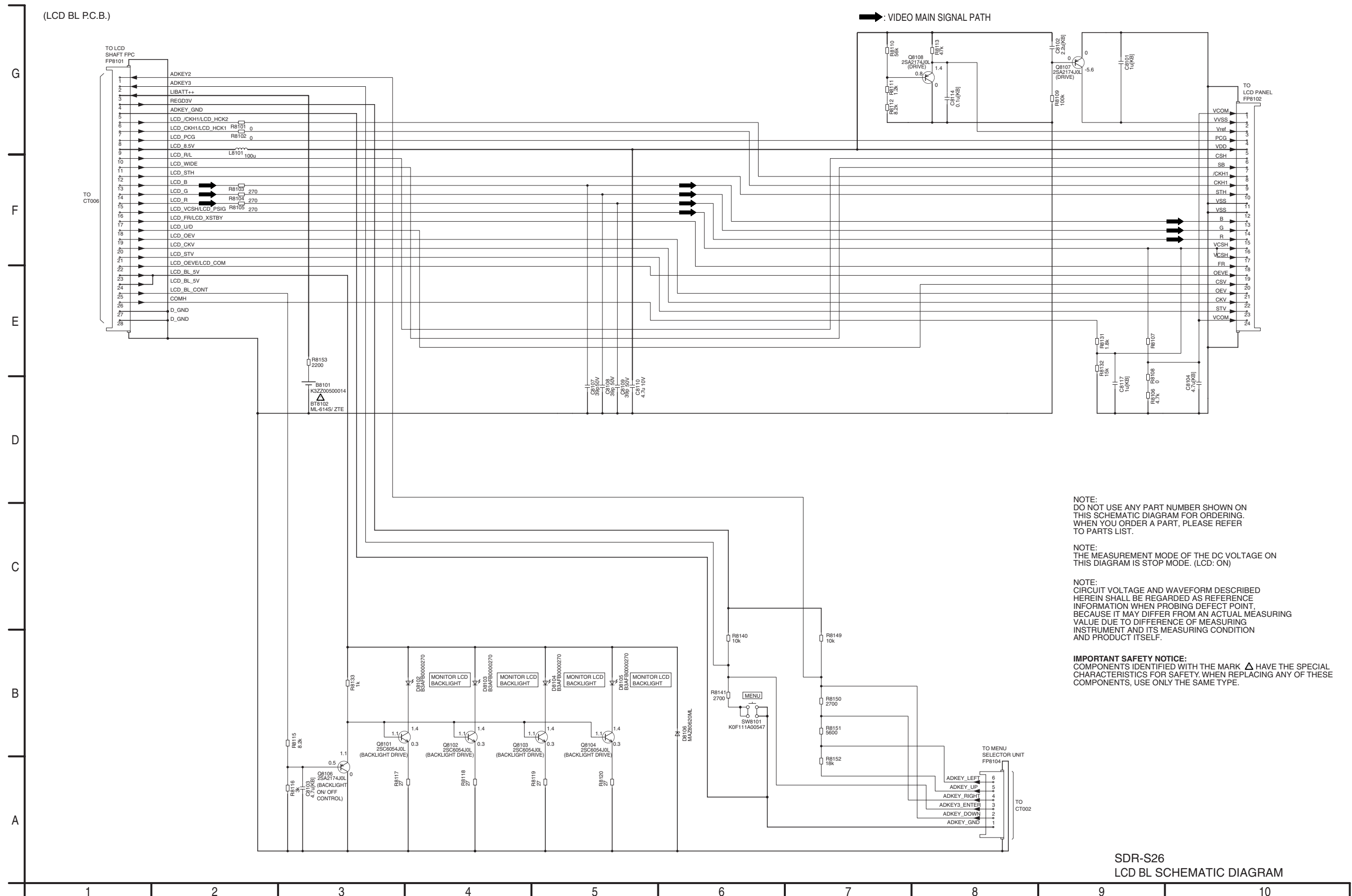

NOTE:
DO NOT USE ANY PART NUMBER SHOWN ON THIS SCHEMATIC DIAGRAM FOR ORDERING. WHEN YOU ORDER A PART, PLEASE REFER TO PARTS LIST.

NOTE:
THE MEASUREMENT MODE OF THE DC VOLTAGE ON THIS DIAGRAM IS STOP MODE. (LCD: ON)

NOTE:
CIRCUIT VOLTAGE AND WAVEFORM DESCRIBED HEREIN SHALL BE REGARDED AS REFERENCE INFORMATION WHEN PROBING DEFECT POINT, BECAUSE IT MAY DIFFER FROM AN ACTUAL MEASURING VALUE DUE TO DIFFERENCE OF MEASURING INSTRUMENT AND ITS MEASURING CONDITION AND PRODUCT ITSELF.

IMPORTANT SAFETY NOTICE:
COMPONENTS IDENTIFIED WITH THE MARK △ HAVE THE SPECIAL CHARACTERISTICS FOR SAFETY. WHEN REPLACING ANY OF THESE COMPONENTS, USE ONLY THE SAME TYPE.

SDR-S26
LCD BL SCHEMATIC DIAGRAM

11.6. TERMINAL FPC SCHEMATIC DIAGRAM

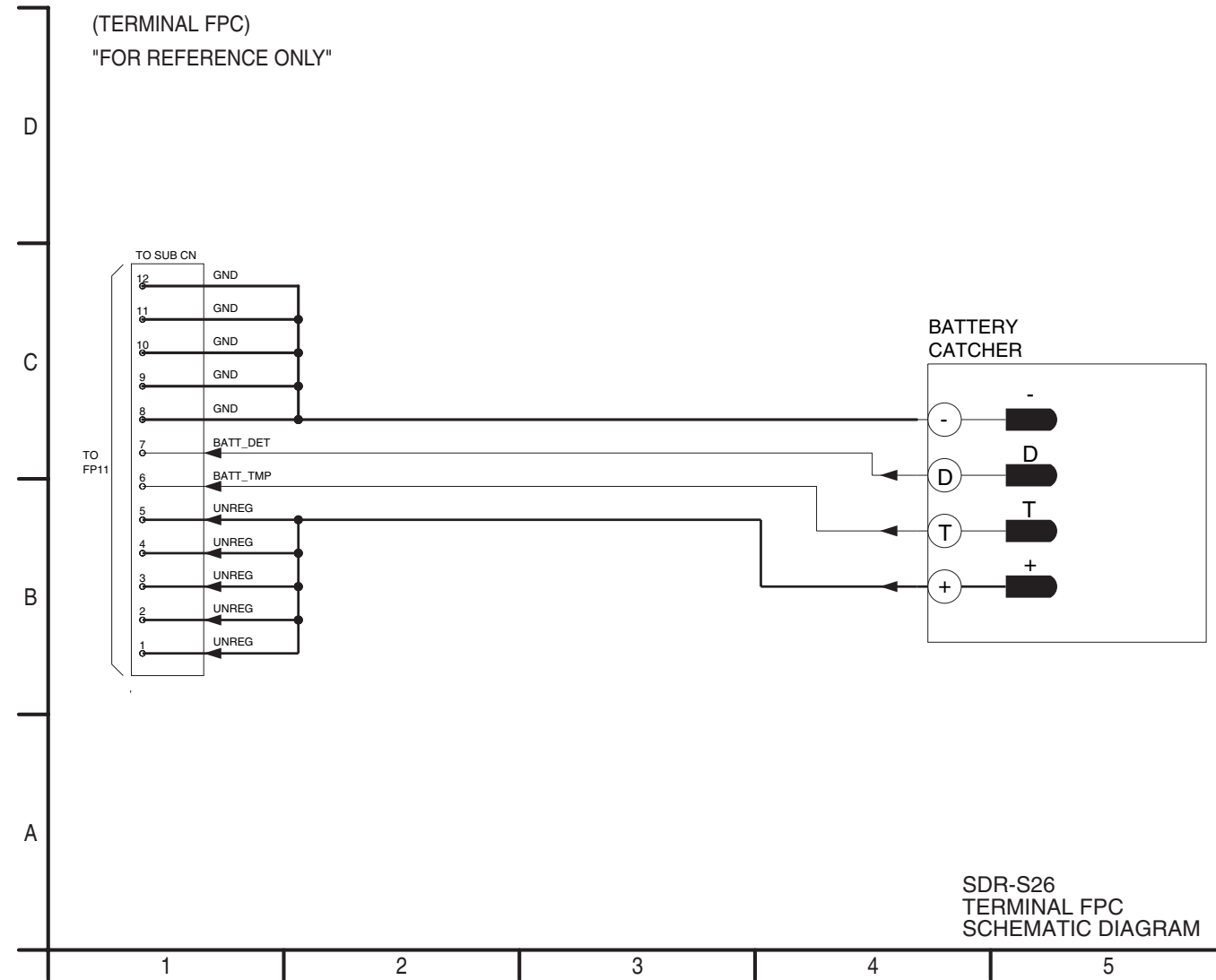

11.7. LCD OPERATION UNIT SCHEMATIC DIAGRAM

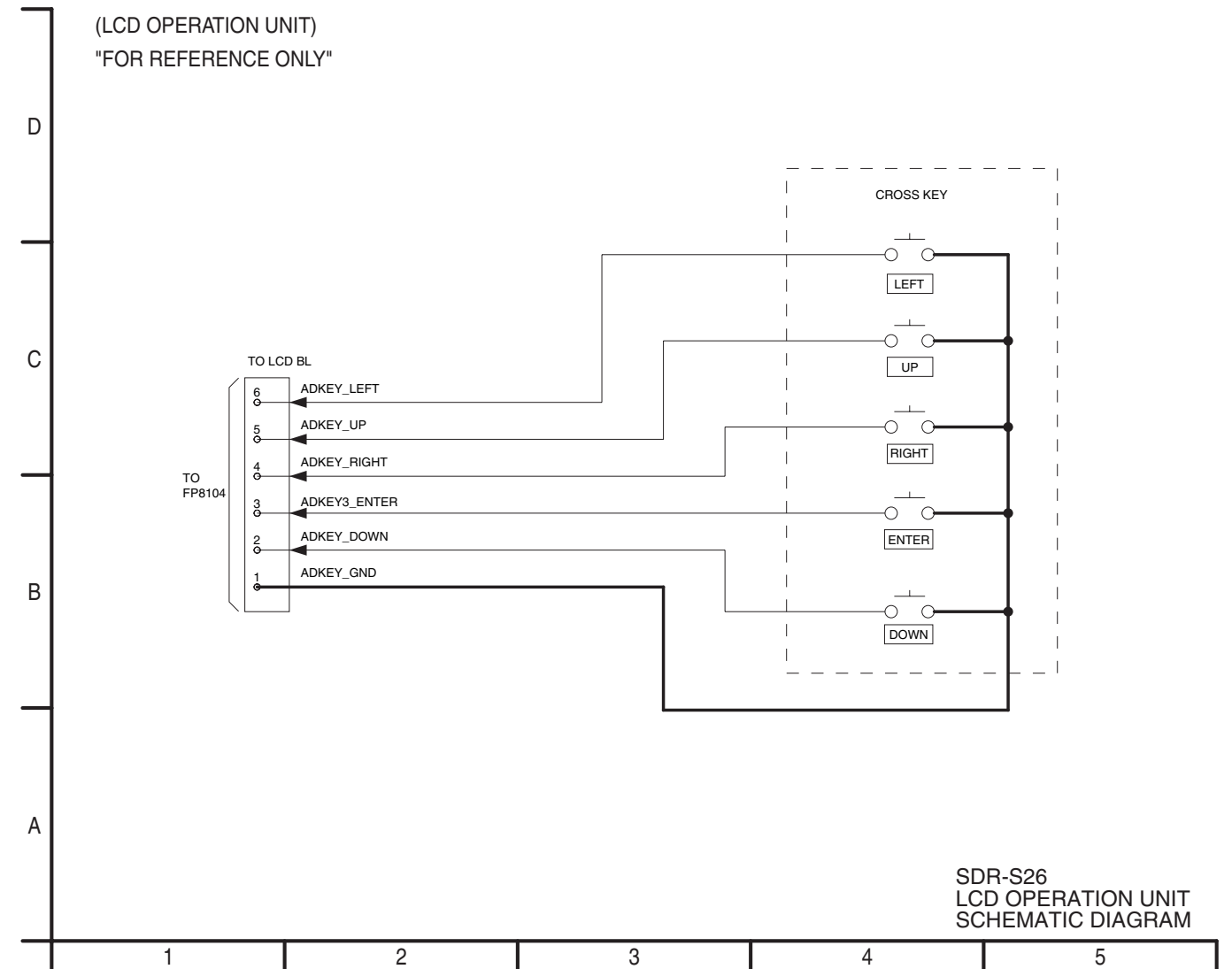

11.8. ECM FPC SCHEMATIC DIAGRAM

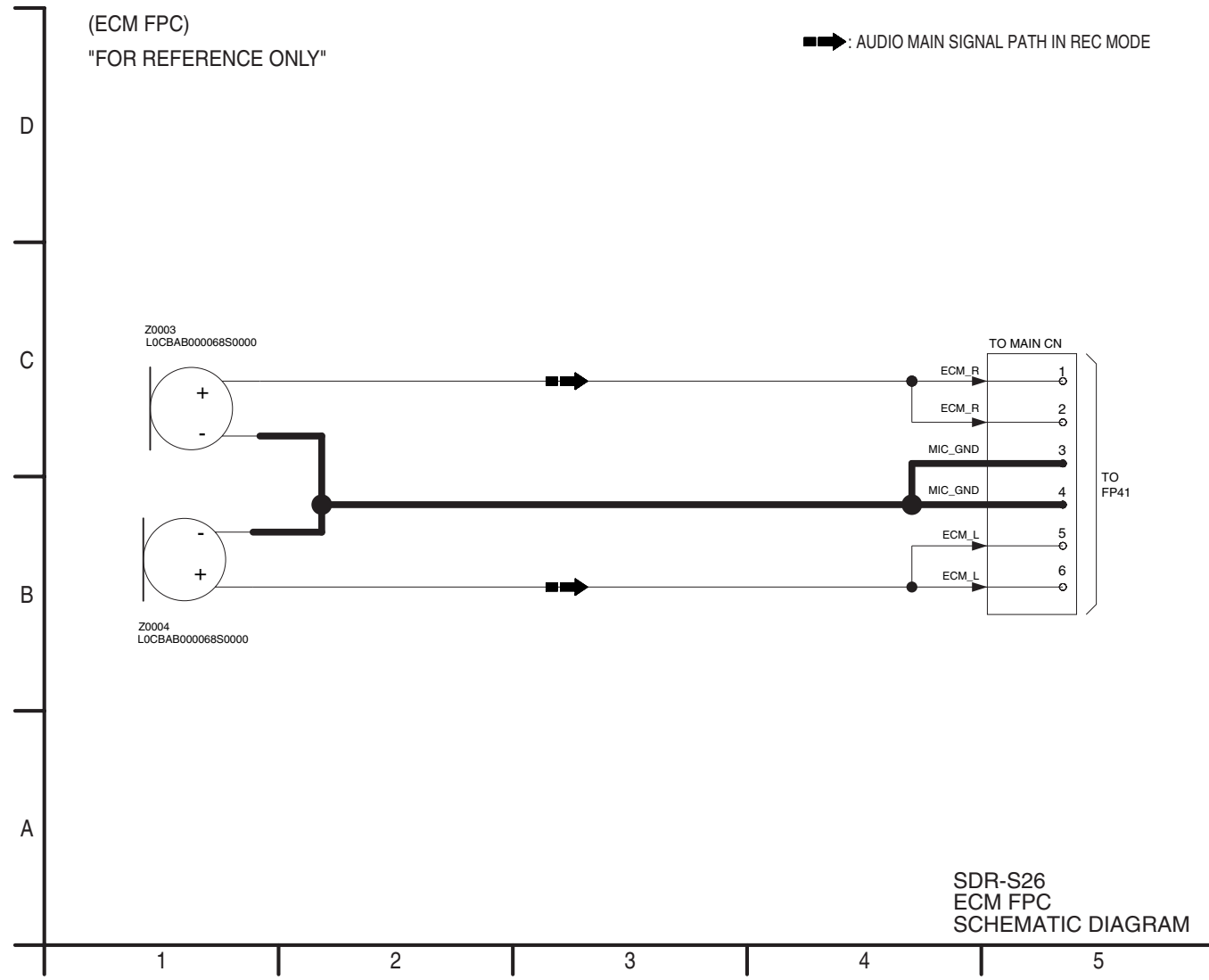

11.9. MODE OPERATION SCHEMATIC DIAGRAM

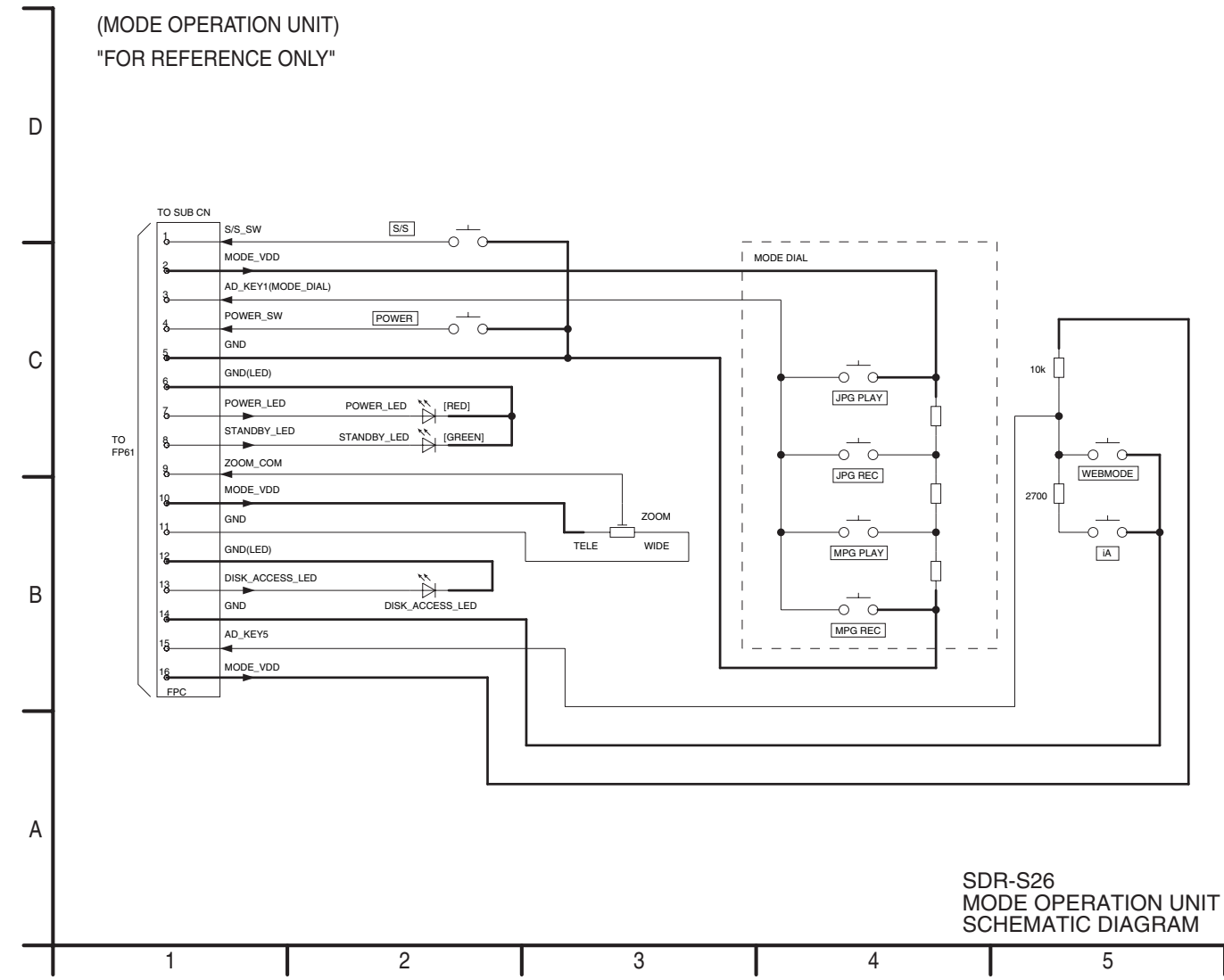

11.10. CCD SCHEMATIC DIAGRAM

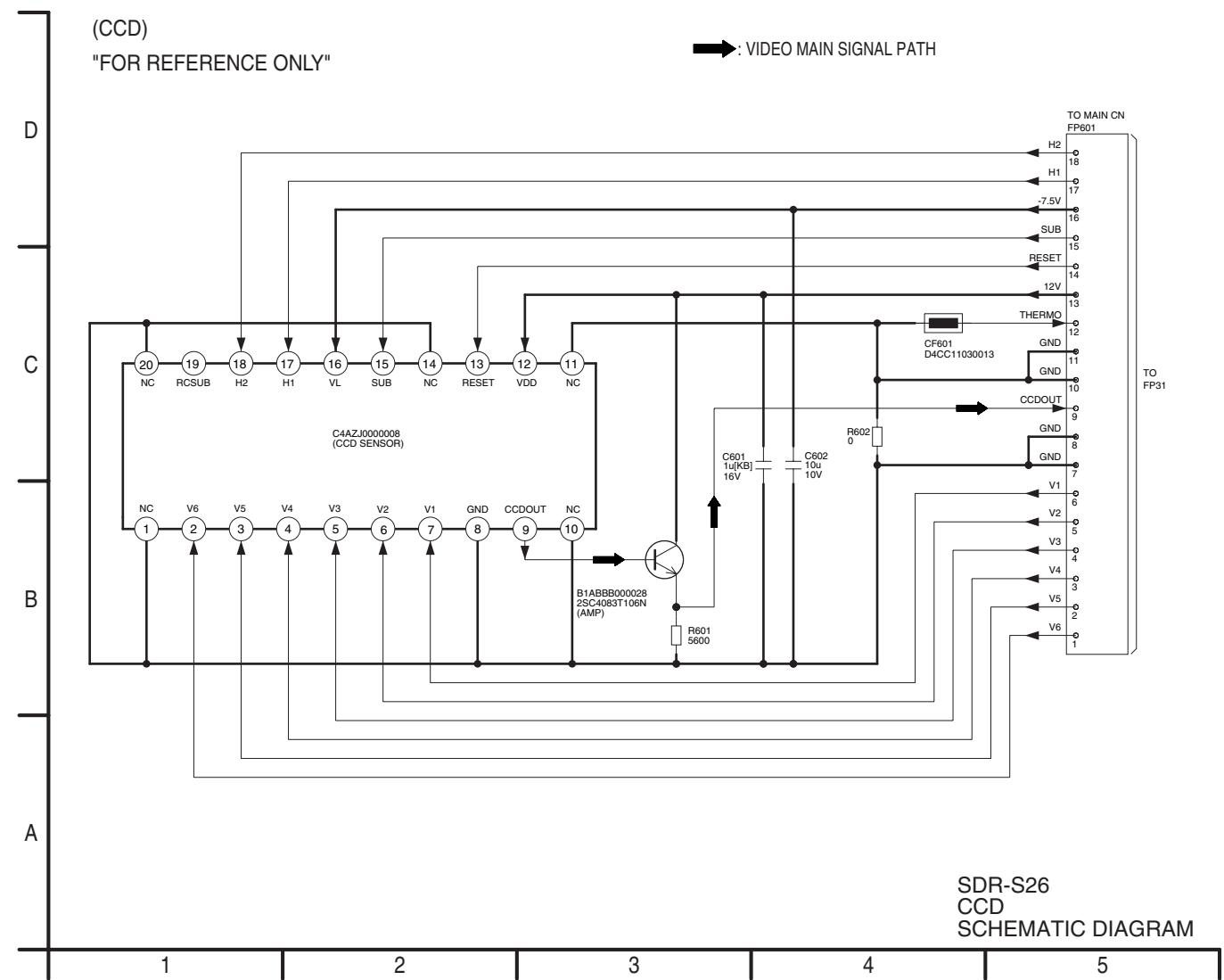

12 Printed Circuit Board

12.1. LCD BL P.C.B.

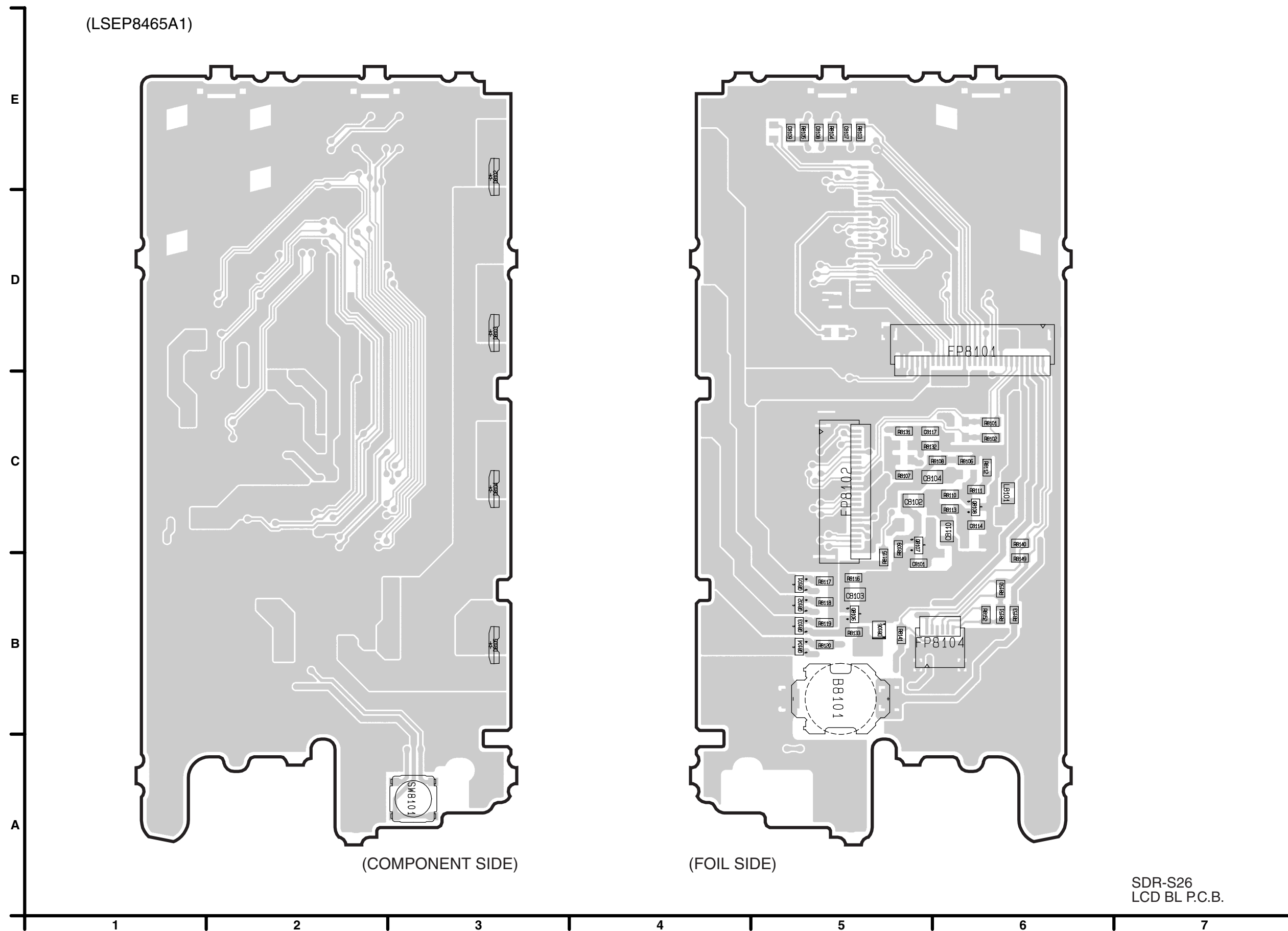

12.2. REAR P.C.B.

(LSEP8464A1)

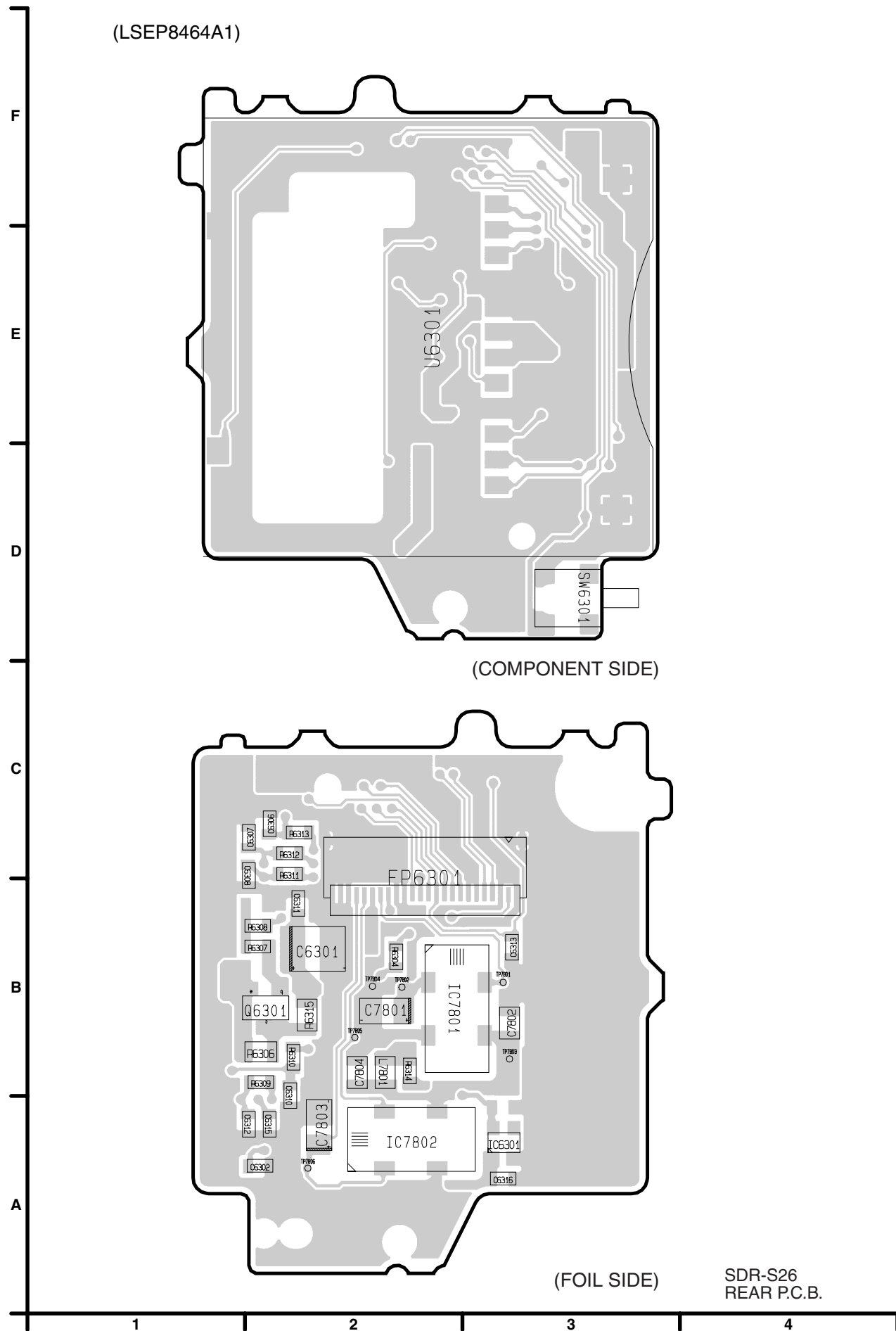

13 Parts and Exploded Views

13.1. Exploded Views

13.1.1. Frame & Casing Section

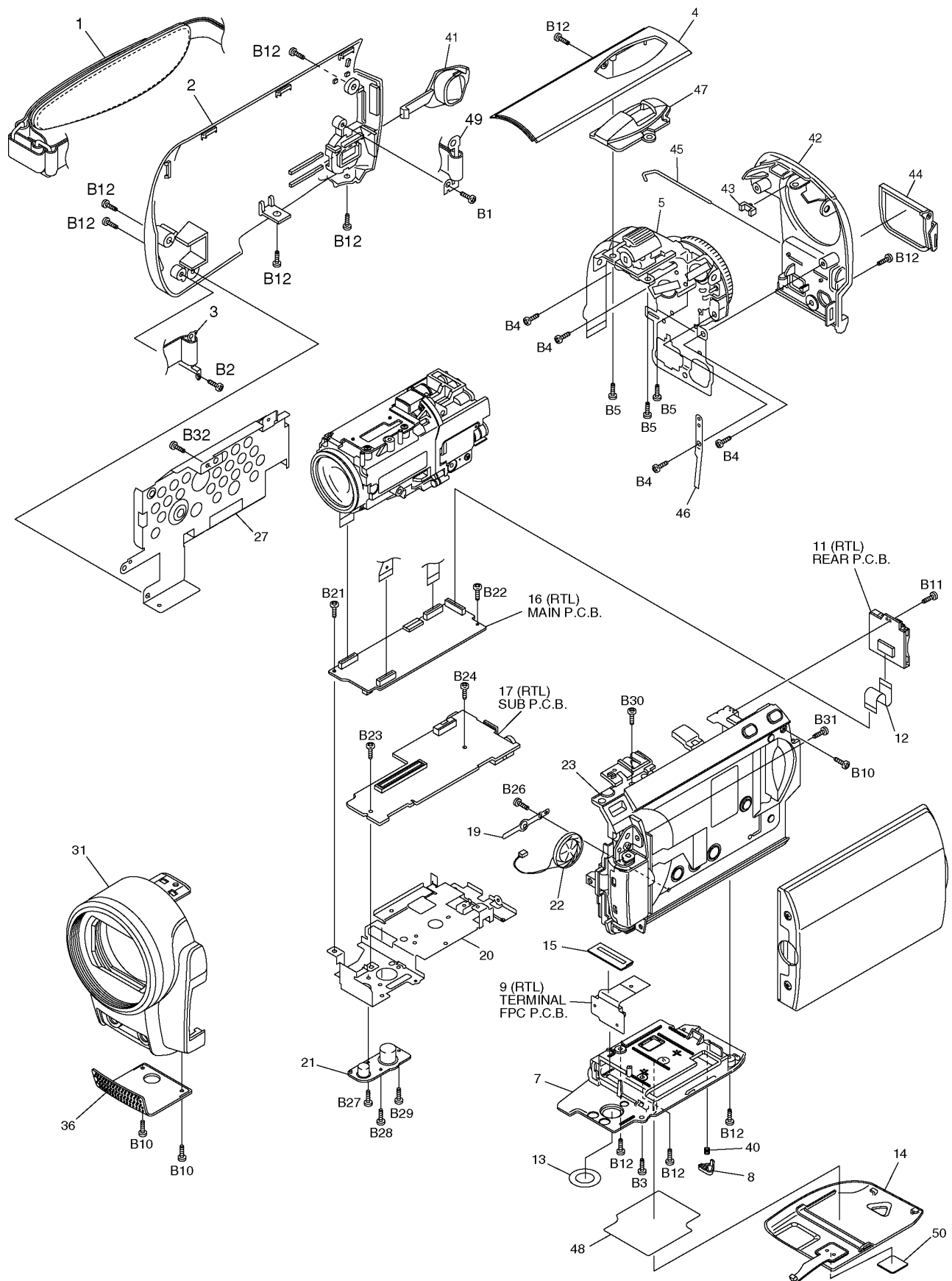

13.1.2. LCD Section

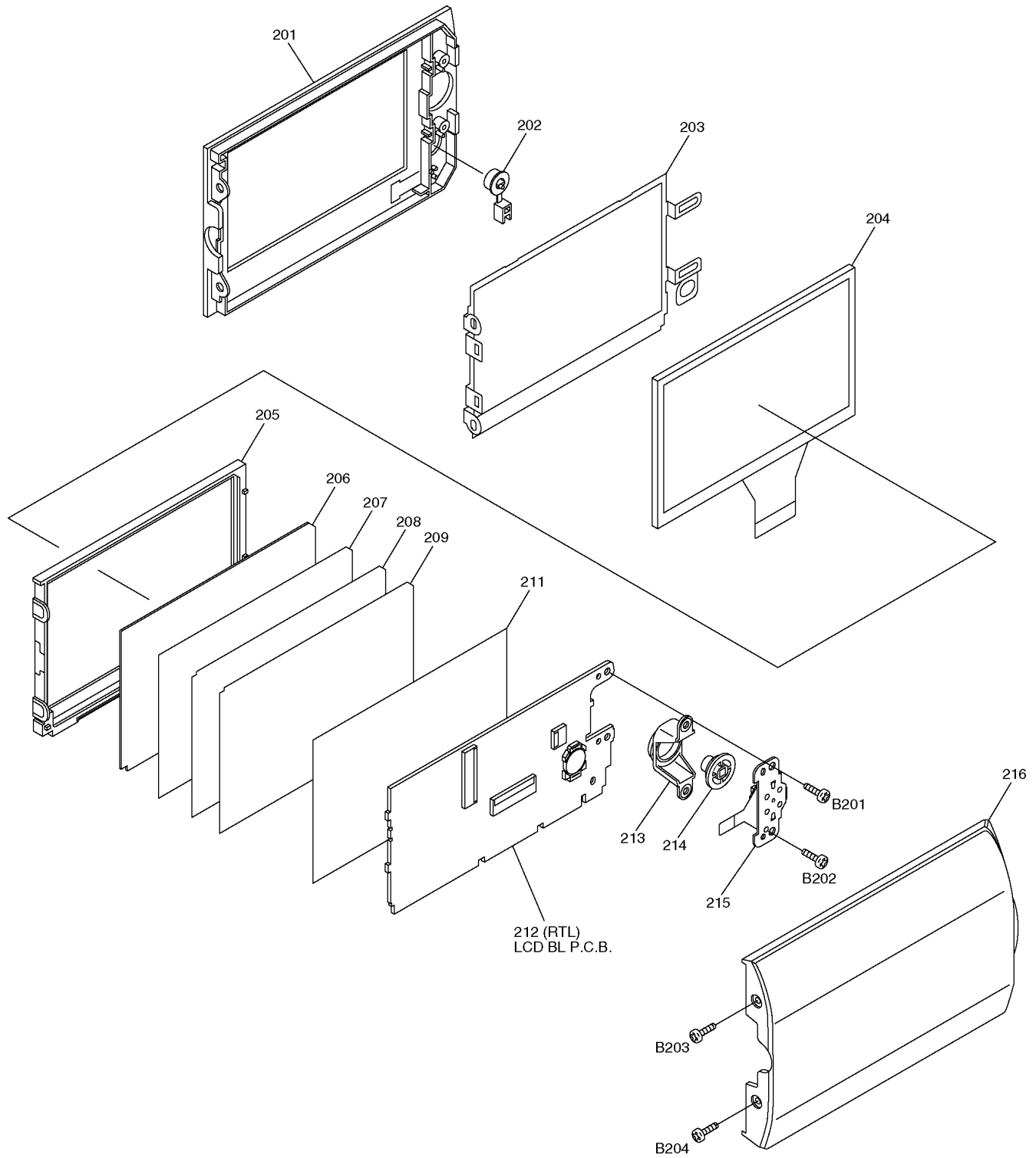

13.1.3. Camera Lens Section

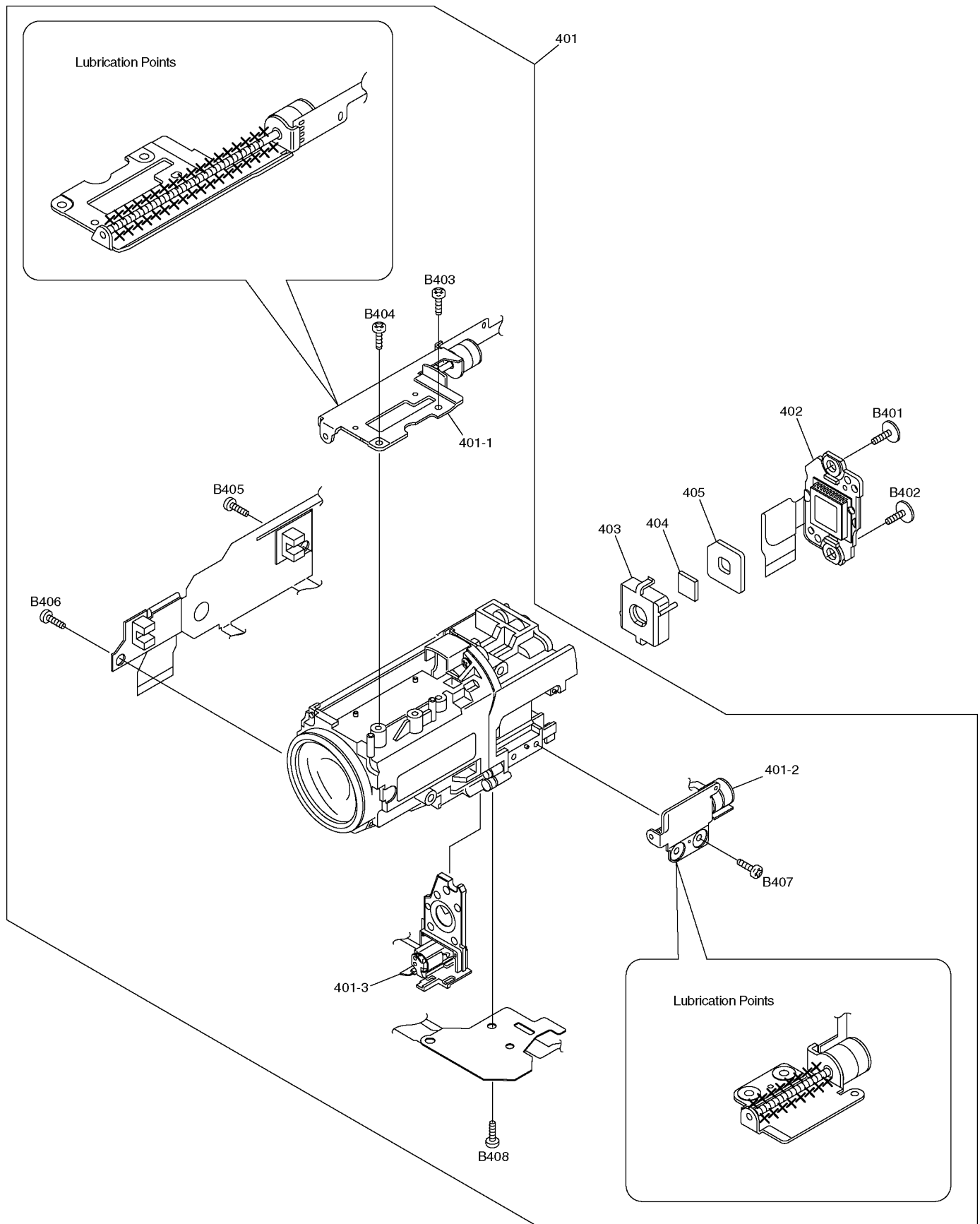

13.1.4. Packing Parts & Accessories Section

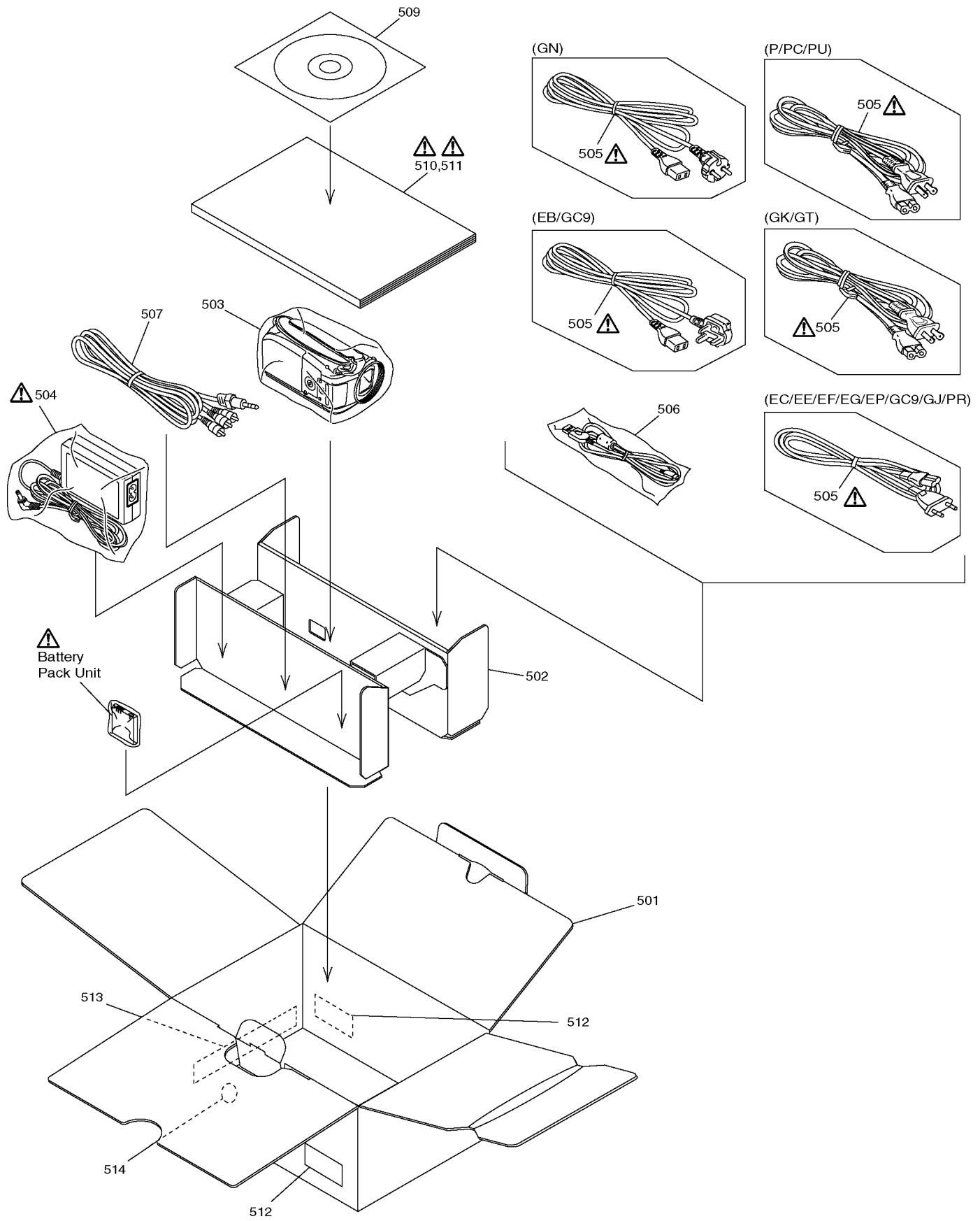

13.2. Replacement Parts List

E.S.D. standards for Electrostatically Sensitive Devices, refer to PREVENTION OF ELECTROSTATIC DISCHARGE (ESD) TO ELECTROSTATICALLY SENSITIVE (ES) DEVICES section.

Definition of Parts supplier:

- All parts are supplied by PSECI.
- Parts marked with [Energy] in the Remarks column are supplied from "Panasonic Corporation Energy Company."

13.2.1. Frame & Casing Section Parts List

Note: 1. *Be sure to make your orders of replacement parts according to this list.
2. IMPORTANT SAFETY NOTICE
Components identified with the mark Δ have the special characteristics for safety. When replacing any of these components, use only the same type.

Ref. No.	Part No.	Part Name & Description	Pcs	Remarks
1	LSGQ0292	GRIP BELT u	1	
2	LSKM1903	GRIP COVER	1	(-A, -N)
2	LSKM1901	GRIP COVER	1	(-K)
2	LSKM1902	GRIP COVER	1	(-R)
3	LSMA1064	STRAP ANGLE	1	
4	LSKM1897	TOP COVER	1	(-A)
4	LSKM1898	TOP COVER	1	(-K)
4	LSKM1893	TOP COVER	1	(-N)
4	LSKM1895	TOP COVER	1	(-R)
5	LSYK2511	MODE OPERATION UNIT	1	
7	LSKM1787	BATTERY CASE	1	(-A, -N, -R)
7	LSKM1858	BATTERY CASE	1	(-K)
8	LSGT0628	BATTERY RELEASE KNOB	1	
9	LSEP8475A1	TERMINAL FPC P.C.B.	1	
11	LSEP8464B1	REAR P.C.B.	1	
12	LSJW0126	FFC 22PIN	1	
13	LSGQ0284	TRIPOD SHEET	1	
14	LSKF0721	BATTERY COVER UNIT	1	(-A, -N)
14	LSKF0728	BATTERY COVER UNIT	1	(-K)
14	LSKF0727	BATTERY COVER UNIT	1	(-R)
15	LSKM1840	BATTERY PIECE	1	
16	LSEP8462G1	MAIN P.C.B.	1	(RTL) E.S.D. P, PC, PR, PU, GT
16	LSEP8462U1	MAIN P.C.B.	1	(RTL) E.S.D. EB, EC, EE, EF, EG, EP, GC9, GJ, GK, GN
17	LSEP8474A1	SUB P.C.B.	1	(RTL) E.S.D. P, PC, PR, PU
17	LSEP8474C1	SUB P.C.B.	1	GT
17	LSEP8474R1	SUB P.C.B.	1	(RTL) E.S.D. EB, EC, EF, EG, EP
17	LSEP8474P1	SUB P.C.B.	1	(RTL) E.S.D. EE, GC9, GJ, GK, GN
19	LSMC0173	SPEAKER ANGLE	1	
20	LSMA1065	TRIPOD FRAME	1	
21	LSHN0021	TRIPOD SCREW	1	
22	L0AA01A00035	LOUDSPEAKERS	1	
23	LSYK2621	SIDE R/SHAFT UNIT	1	PA, PCA, PRA, PU A,
23	LSYK2622	SIDE R/SHAFT UNIT	1	PK, PCK, PRK, PU K,
				GTK
23	LSYK2619	SIDE R/SHAFT UNIT	1	PN, PCN, PUN, PR N,

Ref. No.	Part No.	Part Name & Description	Pcs	Remarks
				GTN
23	LSYK2620	SIDE R/SHAFT UNIT	1	PR, PCR, PRR, PU R,
23	LSYK2625	SIDE R/SHAFT UNIT	1	EBA, ECA, EFA, EGA, EPA,
				GC9A, GJA, GNA
23	LSYK2626	SIDE R/SHAFT UNIT	1	EBK, ECK, EEK, EFK, EGK,
				EPK, GC9K, GJK, GKK, GNK
23	LSYK2623	SIDE R/SHAFT UNIT	1	EBN, ECN, EEN, EGN, EPN,
				GC9N, GJN, GKN, GNN
23	LSYK2624	SIDE R/SHAFT UNIT	1	EBR, ECR, EFR, EGR, EPR,
				GC9R, GJR, GKR, GNR
27	LSMA1063	SIDE L FRAME	1	
31	LSYK2665	FRONT/MIC UNIT	1	(-A)
31	LSYK2652	FRONT/MIC UNIT	1	(-K)
31	LSYK2663	FRONT/MIC UNIT	1	(-N)
31	LSYK2651	FRONT/MIC UNIT	1	(-R)
36	LSYK2559	FRONT PANEL UNIT	1	
40	LSMB0364	BATTERY RELEASE SPRING	1	
41	LSKF0731	USB COVER	1	(-A, -N, -R)
41	LSKF0732	USB COVER	1	(-K)
42	LSKM1790	REAR CASE	1	(-A, -N)
42	LSKM1862	REAR CASE	1	(-K)
42	LSKM1861	REAR CASE	1	(-R)
43	LSGL1549	LED PANEL (POWER)	1	
44	LSKF0718	JACK COVER	1	(-A, -N)
44	LSKF0726	JACK COVER	1	(-K)
44	LSKF0725	JACK COVER	1	(-R)
45	LSMS0324	JACK COVER SHAFT	1	
46	LSMC0174	JACK COVER SPRING	1	
47	LSGK0951	DECO. PIECE(TOP) - SDR-S26	1	
48	LSGN2260	RATING PLATE	1	P Δ ;
48	LSGN2261	RATING PLATE	1	PC Δ
48	LSGN2262	RATING PLATE	1	PR, PU Δ
48	LSGN2264	RATING PLATE	1	GT Δ
48	LSGN2270	RATING PLATE	1	EB, EC, EF, EG, EP, GN Δ
48	LSGN2323	RATING PLATE	1	EEK Δ
48	LSGN2272	RATING PLATE	1	EEN Δ
48	LSGN2278	RATING PLATE	1	GC9 Δ
48	LSGN2271	RATING PLATE	1	GJ Δ
48	LSGN2273	RATING PLATE	1	GK Δ
49	LSMA1066	STRAP ANGLE (REAR)	1	
50	LSQL2678	BATTERY COVER LABEL	1	(-A) (-N)
50	LSQL2679	BATTERY COVER LABEL	1	(-R)
50	LSQL2680	BATTERY COVER LABEL	1	(-K)
B1	XQN16+BJ4FN	SCREW	1	
B2	XQN16+BJ4FN	SCREW	1	
B3	XQN16+BF4FN	SCREW	1	
B4	XQN16+BJ4FN	SCREW	4	
B5	XQN16+BJ4FN	SCREW	3	
B10	XQN16+BF4FJK	SCREW	3	
B11	XQN16+BJ5FJK	SCREW	1	
B12	XQN16+BF4FJK	SCREW	10	
B21	LSHD0132	SCREW	1	
B22	LSHD0132	SCREW	1	
B23	LSHD0132	SCREW	1	
B24	LSHD0132	SCREW	1	
B26	XQN16+BJ4FN	SCREW	1	
B27	XQN16+BF3FN	SCREW	1	

Ref. No.	Part No.	Part Name & Description	Pcs	Remarks
B28	XQN16+BF3FN	SCREW	1	
B29	XQN16+BF3FN	SCREW	1	
B30	XQN16+BJ5FJK	SCREW	1	
B31	XQN16+BJ5FJK	SCREW	1	
B32	XQN16+BJ5FJK	SCREW	1	

13.2.2. LCD Section Parts List

Note: 1. *Be sure to make your orders of replacement parts according to this list.
 2. IMPORTANT SAFETY NOTICE
 Components identified with the mark Δ have the special characteristics for safety. When replacing any of these components, use only the same type.

Ref. No.	Part No.	Part Name & Description	Pcs	Remarks
201	LSKM1785	LCD CASE B	1	
202	LSGU0754	MENU BUTTON	1	
203	LSSC1078	LCD SHIELD CASE	1	
204	L5BDDYH00025	LCD	1	
205	LSYK2499	PANEL HOLDER UNIT	1	
206	LSGL1544	LEAD LIGHT PANEL	1	
207	LSGL1545	LCD BEF SHEET A	1	
208	LSGL1546	LCD BEF SHEET B	1	
209	LSGL1547	LCD DIFFUSION SHEET	1	
211	LSGL1548	LCD REFLECT SHEET	1	
212	LSEP8469A1	LCD BL P.C.B.	1	(RTL)E.S.D.
213	LSGK0937	DECO. PIECE	1	
214	LSGU0755	SELECT LEVER	1	
215	LSSQ1010	LCD OPERATION UNIT	1	
216	LSYK2637	LCD CASE A UNIT	1	PA, PCA, PRA, PUA, EBA, ECA,
				EFA, EGA, EPA, G C9A, GJA, GNA
216	LSYK2638	LCD CASE A UNIT	1	PK, PCK, PRK, PUK, GTK, EBK,
				ECK, EEK, EPK, EGK, EPK, GC9K,
				GJK, GKK, GNK
216	LSYK2635	LCD CASE A UNIT	1	PN, PCN, PUN, GTN, EBN, PRN,
				ECN, EEN, EGN, EPN, GC9N, GJN,
				GKN, GNN
216	LSYK2636	LCD CASE A UNIT	1	PR, PCR, PRR, PUR, EBR, ECR,
				EFR, EGR, EPR, GC9R, GJR, GKR,
				GNR
B201	XQN16+BJ5FN	SCREW	1	
B202	XQN16+BJ5FN	SCREW	1	
B203	XQN16+B3FN	SCREW	1	
B204	XQN16+B3FN	SCREW	1	

13.2.3. Camera Lens Section Parts List

Note: 1. *Be sure to make your orders of replacement parts according to this list.
 2. IMPORTANT SAFETY NOTICE
 Components identified with the mark Δ have the special characteristics for safety. When replacing any of these components, use only the same type.

Ref. No.	Part No.	Part Name & Description	Pcs	Remarks
401	LSXN0057	LENS UNIT	1	
401-1	L6HA66NB0011	ZOOM MOROT UNIT	1	
401-2	L6HA66NB0012	FOCUS MOTOR UNIT	1	
401-3	LSEM0114	AUTO IRIS UNIT	1	
402	LSEP8466A1	CCD P.C.B.	1	(RTL)E.S.D.
403	LSDW0141	CCD CASE	1	
404	LSFLO343	KL105 OLPF	1	
405	LSMX0246	CCD CUSHION	1	
B401	LSHD0136	SCREW	1	
B402	LSHD0136	SCREW	1	
B403	XQN16+BJ4FN	SCREW	1	
B404	XQN16+BJ4FN	SCREW	1	
B405	XQN16+BJ4FN	SCREW	1	
B406	XQN16+BJ4FN	SCREW	1	
B407	XQN16+BJ4FN	SCREW	1	
B408	XQN16+BJ4FN	SCREW	1	

13.2.4. Packing Parts & Accessories Section Parts List

Note: 1. *Be sure to make your orders of replacement parts according to this list.
 2. IMPORTANT SAFETY NOTICE
 Components identified with the mark Δ have the special characteristics for safety. When replacing any of these components, use only the same type.
 3. Supply of CD-ROM, in accordance with license protection, is allowable as replacement parts only for customers who accidentally damaged or lost their own.

Ref. No.	Part No.	Part Name & Description	Pcs	Remarks
501	LSPG2692	PACKING CASE	1	P, PC, PU, PR
501	LSPG2696	PACKING CASE	1	GT, EG, EC, EB, G J, GN, GC9, EP, GK, EE
501	LSPG2749	PACKING CASE	1	EF
502	LSPN0950	PAD	1	
503	VPF1129	PROTECTION BAG	1	
504	VSK0694-M	AC ADAPTOR	1	P, PC Δ
504	VSK0702-M	AC ADAPTOR	1	PR Δ
504	VSK0695-M	AC ADAPTOR	1	PU, EB, EC, EE, E F, EG, EP, GC9, Δ
				GJ, GK, GN
504	VSK0703	AC ADAPTOR	1	GT Δ
505	K2CA2CA00029	AC CORD	1	P, PC, PU Δ
505	K2CJ2DA00006	AC CORD	1	PR Δ
505	K2CT3CA00004	AC CORD	1	EB, GC9 Δ
505	K2CQ2CA00006	AC CORD	1	EC, EE, EF, EG, E P, GC9
505	K2CP2YY00001	AC CORD	1	GJ Δ
505	K2CA2CA00020	AC CORD	1	GK Δ
505	K2CJ2DA00011	AC CORD	1	GN Δ
505	K2CA2CA00028	AC CORD	1	GT Δ
506	K1HA05AD0005	USB CABLE	1	P, PC
506	K1HA05AD0006	USB CABLE	1	PR, PU, GT, EB, E C, EE, EF, EG, EP, GC9, GJ, GK, GN
507	K2KC4CB00022	AV CABLE	1	
509	LSFT0771-C	CD-ROM	1	
510	LSQT1488-A	O/I (ENGLISH)	1	P, PC Δ
510	LSQT1489-A	O/I (CANADIAN FRENCH)	1	PC Δ
510	LSQT1529-A	O/I (SPANISH)	1	PR, PU Δ
510	LSQT1490-A	O/I (ENGLISH)	1	PU Δ
510	LSQT1525-A	O/I (TAIWANESE)	1	GT Δ
510	LSQT1511-A	O/I (ENGLISH)	1	EB Δ

Ref. No.	Part No.	Part Name & Description	Pcs	Remarks
510	LSQT1499-A	O/I (PORTUGUESE/SPANISH)	1	EC △
510	LSQT1553-A	O/I (FINNISH)	1	EC △
510	LSQT1500-A	O/I (SWEDISH/DANISH)	1	EC △
510	LSQT1521-A	O/I (RUSSIAN/UKRAINIAN)	1	EE △
510	LSQT1493-A	O/I (FRENCH)	1	EF △
510	LSQT1491-A	O/I (GERMAN/TARKISH)	1	EG △
510	LSQT1492-A	O/I (ITALIAN/DUTCH)	1	EG △
510	LSQT1556-A	O/I (FRENCH)	1	EG △
510	LSQT1505-A	O/I (ENGLISH/POLISH)	1	EP △
510	LSQT1506-A	O/I (CZECH/HUNGARIAN)	1	EP △
510	LSQT1512-A	O/I (ENGLISH/THAI)	1	GJ △
510	LSQT1524-A	O/I	1	GK △
510	LSQT1522-A	O/I	1	GN △
511	LSQT1494-A	O/I (GERMAN) (CD-ROM)	1	EG △
511	LSQT1495-A	O/I (FRENCH) (CD-ROM)	1	EG △
511	LSQT1496-A	O/I (ITALIAN) (CD-ROM)	1	EG △
511	LSQT1497-A	O/I (DUTCH) (CD-ROM)	1	EG △
511	LSQT1498-A	O/I (TARKISH) (CD-ROM)	1	EG △
511	LSQT1501-A	O/I (PORTUGUESE) (CD-ROM)	1	EC △
511	LSQT1502-A	O/I (SPANISH) (CD-ROM)	1	EC △
511	LSQT1503-A	O/I (SWEDISH) (CD-ROM)	1	EC △
511	LSQT1504-A	O/I (DANISH) (CD-ROM)	1	EC △
511	LSQT1550-A	O/I (FINNISH) (CD-ROM)	1	EC △
511	LSQT1507-A	O/I (ENGLISH) (CD-ROM)	1	EP △
511	LSQT1508-A	O/I (POLISH) (CD-ROM)	1	EP △
511	LSQT1509-A	O/I (CZECH) (CD-ROM)	1	EP △
511	LSQT1510-A	O/I (HUNGARIAN) (CD-ROM)	1	EP △
511	LSQT1515-A	O/I (ENGLISH) (CD-ROM)	1	GC9 △
511	LSQT1516-A	O/I (THAI) (CD-ROM)	1	GC9 △
511	LSQT1517-A	O/I (ARABIC) (CD-ROM)	1	GC9 △
511	LSQT1518-A	O/I (PERSIAN) (CD-ROM)	1	GC9 △
511	LSQT1519-A	O/I (TAIWANESE) (CD-ROM)	1	GC9 △
511	LSQT1520-A	O/I (CHINESE (TRADITIONAL)) (CD-ROM)	1	GC9 △
512	VQL1Z07	COLOR LABEL	2	PK, PCK, PUK, PRK
512	VQL1R90	COLOR LABEL	2	PR, PCR, PUR, PRR
512	VQL1U88	COLOR LABEL	2	PA, PCA, PUA, PRA
512	VQL1Z08	COLOR LABEL	2	GTK, EGK, ECK, EBK, GJK, GNK, EPK, GC9K, GKK, EEK
512	VQL1U87	COLOR LABEL	2	GTR, EGR, ECR, EBR, GJR, GNR, EPR, GC9R, GKR, EER

Ref. No.	Part No.	Part Name & Description	Pcs	Remarks
512	VQL1U89	COLOR LABEL	2	GTA, EGA, ECA, EBA, GJA, GNA, EPA, GC9A, GKA, EEA
512	VQL1R91	COLOR LABEL	2	EFR
512	VQL1Z36	COLOR LABEL	2	EFA
513	VQL1Q72	LANGEAGE LABEL	1	EP
513	VQL1Q23	LANGEAGE LABEL	1	GC9
513	VQL1L35	LANGEAGE LABEL	1	GK
514	LSQL2682	GK PSECI LABEL	1	GK
514	LSQL2681	GT PSECI LABEL	1	GT

13.2.5. Electrical Replacement Parts List

Note: 1. Be sure to make your orders of replacement parts according to this list.
2. IMPORTANT SAFETY NOTICE: Components identified with the mark △ have the special characteristics for safety. When replacing any of these components, use only the same type.
3. Unless otherwise specified,
All resistors are in OHMS, K=1,000 OHMS. All capacitors are in MICROFARADS (uf), P=μuf.
4. The P.C. Board units marked with "■" show below the main assembled parts.
5. The marking (RTL) indicates the retention time is limited for this item.
After the discontinuation of this assembly in production, it will no longer be available.

Ref. No.	Part No.	Part Name & Description	Pcs	Remarks
■	LSEP8464B1	REAR P.C.B.		
C6301	F3G0J107A017	C. CAPACITOR CH 6.3V 100U	1	
C6302	ECJ1VB1E103K	C. CAPACITOR CH 25V 0.01U	1	
C6306	F1H1H2700008	C. CAPACITOR CH 50V 27P	1	
C6307	F1H1H2700008	C. CAPACITOR CH 50V 27P	1	
C6308	F1H1H2700008	C. CAPACITOR CH 50V 27P	1	
C6310	F1H1H2700008	C. CAPACITOR CH 50V 27P	1	
C6311	ECJ1VB1E103K	C. CAPACITOR CH 25V 0.01U	1	
C6312	F1H1H2700008	C. CAPACITOR CH 50V 27P	1	
C6313	F1H1C104A075	C. CAPACITOR CH 16V 0.1U	1	
C6315	F1H1C104A075	C. CAPACITOR CH 16V 0.1U	1	
C7801	F3F0J226A055	E. CAPACITOR CH 6.3V 22U	1	
C7802	F1J1A106A043	C. CAPACITOR CH 10V 10U	1	
C7803	F3F0J226A055	E. CAPACITOR CH 6.3V 22U	1	
C7804	F1J1A106A043	C. CAPACITOR CH 10V 10U	1	
FP6301	K1MN22BA0197	CONNECTOR 22P	1	
IC7801	L2ES00000019	IC	1	E.S.D.
IC7802	L2ES00000018	IC	1	E.S.D.
L7801	G1C100KA0031	COIL	1	
Q6301	2SB09700RL	TRANSISTOR	1	E.S.D.
R6302	ERJ3GEY0R00	M. RESISTOR CH 1/10W 0	1	
R6304	ERJ3GEYJ560	M. RESISTOR CH 1/10W 56	1	
R6306	ERJ6GEYJ150V	M. RESISTOR CH 1/10W 15	1	
R6307	ERJ3GEYJ561	M. RESISTOR CH 1/10W 560	1	
R6308	ERJ3GEY0R00	M. RESISTOR CH 1/10W 0	1	
R6309	ERJ3GEYJ330	M. RESISTOR CH 1/10W 33	1	

Ref. No.	Part No.	Part Name & Description	Pcs	Remarks
R6310	ERJ3GEYJ330	M.RESISTOR CH 1/10W 33	1	
R6311	ERJ3GEYJ330	M.RESISTOR CH 1/10W 33	1	
R6312	ERJ3GEYJ330	M.RESISTOR CH 1/10W 33	1	
R6313	ERJ3GEYJ330	M.RESISTOR CH 1/10W 33	1	
R6315	ERJ6GEY0R00V	M.RESISTOR CH 1/10W 0	1	
SW6301	ESE13H01D	SWITCH	1	
U6301	K1NA09E00063	CONNECTOR 9P	1	
■	LSEP8466A1	CCD P.C.B.		(RTL) E.S.D.
C601	ECJ2FB1C105K	C.CAPACITOR CH 16V 1U	1	
C602	F1J1A106A043	C.CAPACITOR CH 10V 10U	1	
CF601	D4CC11030013	THERMISTOR	1	
Q601	B1ABBB000028	TRANSISTOR	1	E.S.D.
R601	ERJ2GEJ562	M.RESISTOR CH 1/16W 5.6K	1	
R602	ERJ6GEY0R00V	M.RESISTOR CH 1/10W 0	1	
■	LSEP8469A1	LCD BL P.C.B.		(RTL) E.S.D.
B8101	K3Z200500014	CONNECTOR	1	
BT8102	ML-614S/ZTE	BATTERY	1	[Energy] Δ
C8101	ECJ1VB1A105K	C.CAPACITOR CH 10V 1U	1	
C8102	ECJ2FB1A225K	C.CAPACITOR CH 10V 2.2U	1	
C8103	ECJ2FB0J475K	C.CAPACITOR CH 6.3V 4.7U	1	
C8106	ECJ1VB1A105K	C.CAPACITOR CH 10V 1U	1	
C8107	ECJ1VC1H390J	C.CAPACITOR CH 50V 39P	1	
C8108	ECJ1VC1H390J	C.CAPACITOR CH 50V 39P	1	
C8109	ECJ1VC1H390J	C.CAPACITOR CH 50V 39P	1	
C8110	ECJ2FB1A475K	C.CAPACITOR CH 10V 4.7U	1	
C8114	ECJ1XB1C104K	C.CAPACITOR CH 16V 0.1U	1	
D8101	MAZ80560ML	DIODE	1	E.S.D.
D8102	B3AFB0000270	DIODE	1	E.S.D.
D8103	B3AFB0000270	DIODE	1	E.S.D.
D8104	B3AFB0000270	DIODE	1	E.S.D.
D8105	B3AFB0000270	DIODE	1	E.S.D.
D8106	MAZ80620ML	DIODE	1	E.S.D.
FP8101	K1MN28BA0197	CONNECTOR 28P	1	
FP8103	K1MN24BA0197	CONNECTOR 24P	1	
FP8104	K1MN06BA0197	CONNECTOR 6P	1	
L8101	G1C101KA0055	CHIP INDUCTOR 100UH	1	
Q8101	2SC6054J0L	TRANSISTOR	1	E.S.D.
Q8102	2SC6054J0L	TRANSISTOR	1	E.S.D.
Q8103	2SC6054J0L	TRANSISTOR	1	E.S.D.
Q8104	2SC6054J0L	TRANSISTOR	1	E.S.D.
Q8106	2SA2174J0L	TRANSISTOR	1	E.S.D.
Q8107	2SA2174J0L	TRANSISTOR	1	E.S.D.
Q8108	2SA2174J0L	TRANSISTOR	1	E.S.D.

Ref. No.	Part No.	Part Name & Description	Pcs	Remarks
R8101	ERJ3GEY0R00	M.RESISTOR CH 1/10W 0	1	
R8102	ERJ3GEY0R00	M.RESISTOR CH 1/10W 0	1	
R8103	ERJ3RBD271	M.RESISTOR CH 1/10W 270	1	
R8104	ERJ3RBD271	M.RESISTOR CH 1/10W 270	1	
R8105	ERJ3RBD271	M.RESISTOR CH 1/10W 270	1	
R8109	ERJ3GEYJ104	M.RESISTOR CH 1/10W 100K	1	
R8110	ERJ3RBD563V	M.RESISTOR CH 1/10W 56K	1	
R8112	ERJ3RBD562	M.RESISTOR CH 1/10W 5.6K	1	
R8113	DOGB473JA057	M.RESISTOR CH 1/10W 47K	1	
R8115	ERJ3RBD822	M.RESISTOR CH 1/10W 8.2K	1	
R8116	ERJ3RBD302	M.RESISTOR CH 1/10W 3K	1	
R8117	ERJ3RED270	M.RESISTOR CH 1/10W 27	1	
R8118	ERJ3RED270	M.RESISTOR CH 1/10W 27	1	
R8119	ERJ3RED270	M.RESISTOR CH 1/10W 27	1	
R8120	ERJ3RED270	M.RESISTOR CH 1/10W 27	1	
R8133	DOGB102JA057	M.RESISTOR CH 1/10W 1K	1	
R8140	DOGB103JA057	M.RESISTOR CH 1/10W 10K	1	
R8141	ERJ3GEYJ272	M.RESISTOR CH 1/10W 2.7K	1	
R8149	DOGB103JA057	M.RESISTOR CH 1/10W 10K	1	
R8150	ERJ3GEYJ272	M.RESISTOR CH 1/10W 2.7K	1	
R8151	ERJ3GEYJ562	M.RESISTOR CH 1/10W 5.6K	1	
R8152	DOGB183JA057	M.RESISTOR CH 1/10W 18K	1	
R8153	ERJ3GEYJ222	M.RESISTOR CH 1/10W 2.2K	1	
SW8101	KOF111A00547	SWITCH	1	