

# Service Manual

High Definition Video Camera

Model No. **HDC-HS20P**

**HDC-HS20PU**

**HDC-HS20EG**

**HDC-HS20EE**

**HDC-HS20EB**

**HDC-HS20EC**

**HDC-HS20EP**

**HDC-HS20GC**

**HDC-HS20GK**

**HDC-HS20EF**

**HDC-HS20GJ**

**HDC-HS20GN**

**HDC-HS20GT**

**HDC-HS20PC**

**HDC-HS20SG**

**HDC-HS25EB**

AVCHD™

DOLBY  
DIGITAL  
5.1 CREATOR

HDMI™  
HIGH DEFINITION MULTIMEDIA INTERFACE



SD  
HC  
CLASS 4

VIERA Link™

LEICA  
DICOMAR

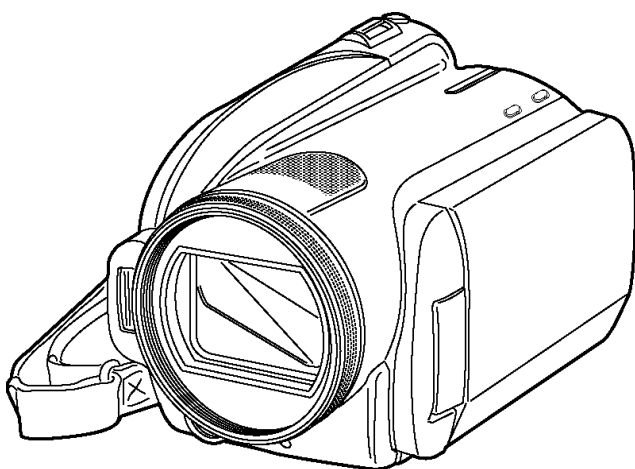

VOL.1

Colours

(K).....Black Type

## WARNING

This service information is designed for experienced repair technicians only and is not designed for use by the general public. It does not contain warnings or cautions to advise non-technical individuals of potential dangers in attempting to service a product. Products powered by electricity should be serviced or repaired only by experienced professional technicians. Any attempt to service or repair the product or products dealt with in this service information by anyone else could result in serious injury or death.

**Panasonic®**

© Panasonic Corporation 2009.  
Unauthorized copying and distribution is a violation  
of law.

# TABLE OF CONTENTS

	PAGE	PAGE
<b>1 Safety Precaution</b> .....	<b>3</b>	
1.1. General Guidelines .....	3	
<b>2 Warning</b> .....	<b>4</b>	
2.1. Prevention of Electrostatic Discharge (ESD) to Electrostatic Sensitive (ES) Devices .....	4	
2.2. Service caution based on legal restrictions .....	5	
2.3. Caution for AC Cord (For EB/GC/SG) .....	6	
2.4. How to Replace the Lithium Battery (PROCEDURE) .....	7	
2.5. How to Recycle the Lithium Battery (U.S. Only) .....	8	
<b>3 Service Navigation</b> .....	<b>9</b>	
3.1. Service Information .....	9	
3.2. Service Caution .....	10	
3.3. Precautions for Handling HDD .....	11	
3.4. Formatting HDD .....	15	
<b>4 Specifications</b> .....	<b>16</b>	
<b>5 Location of Controls and Components</b> .....	<b>17</b>	
<b>6 Service Mode</b> .....	<b>22</b>	
6.1. Service Menu .....	22	
6.2. About Default Setting .....	27	
<b>7 Service Fixture &amp; Tools</b> .....	<b>28</b>	
7.1. Service Tools and Equipment .....	28	
<b>8 Disassembly and Assembly Instructions</b> .....	<b>29</b>	
8.1. Disassembly Flow Chart .....	29	
8.2. P.C.B. Layout .....	29	
8.3. Disassembly Procedures .....	30	
8.4. Disassembly Procedures of Camera Lens Unit .....	41	
<b>9 Measurements and Adjustments</b> .....	<b>42</b>	
9.1. EEPROM Data for spare parts of the MAIN P.C.B. .....	42	
9.2. Service Positions .....	42	
9.3. Location for Connectors of the Main P.C.B. and Sub P.C.B. .....	44	
9.4. Electrical Adjustment Procedures .....	46	
<b>10 Maintenance</b> .....	<b>49</b>	
10.1. Cleaning Lens and LCD Panel .....	49	

# 1 Safety Precautions

## 1.1. General Guidelines

### 1. IMPORTANT SAFETY NOTICE

There are special components used in this equipment which are important for safety. These parts are marked by in the Schematic Diagrams, Circuit Board Layout, Exploded Views and Replacement Parts List. It is essential that these critical parts should be replaced with manufacturer's specified parts to prevent X-RADIATION, shock fire, or other hazards. Do not modify the original design without permission of manufacturer.

2. An Isolation Transformer should always be used during the servicing of AC Adaptor whose chassis is not isolated from the AC power line. Use a transformer of adequate power rating as this protects the technician from accidents resulting in personal injury from electrical shocks. It will also protect AC Adaptor from being damaged by accidental shorting that may occur during servicing.
3. When servicing, observe the original lead dress. If a short circuit is found, replace all parts which have been overheated or damaged by the short circuit.
4. After servicing, see to it that all the protective devices such as insulation barriers, insulation papers shields are properly installed.
5. After servicing, make the following leakage current checks to prevent the customer from being exposed to shock hazards.

### 1.1.1. Leakage Current Cold Check

1. Unplug the AC cord and connect a jumper between the two prongs on the plug.
2. Measure the resistance value, with an ohmmeter, between the jumpered AC plug and each exposed metallic cabinet part on the equipment such as screwheads, connectors, control shafts, etc. When the exposed metallic part has a return path to the chassis, the reading should be between  $1M\Omega$  and  $5.2M\Omega$ . When the exposed metal does not have a return path to the chassis, the reading must be infinity.

### 1.1.2. Leakage current hot check (See Figure 1)

1. Plug the AC cord directly into the AC outlet. Do not use an isolation transformer for this check.
2. Connect "A" to exposed metallic part on the set. And connect "B" to a good earth ground, as shown in Figure 1.
3. Use an AC voltmeter, with  $1\text{ k}\Omega/\text{V}$  or more sensitivity, to measure the potential across the resistor.
4. Check each exposed metallic part, and measure the voltage at each point.
5. Reverse the AC plug in the AC outlet and repeat each of the above measurements.
6. The potential at any point should not exceed  $0.25\text{ V RMS}$ . A leakage current tester (Simpson Model 229 or equivalent) may be used to make the hot checks, leakage current must not exceed  $1/2\text{ mA}$ . In case a measurement is outside of the limits specified, there is a possibility of a shock hazard, and the equipment should be repaired and rechecked before it is returned to the customer.

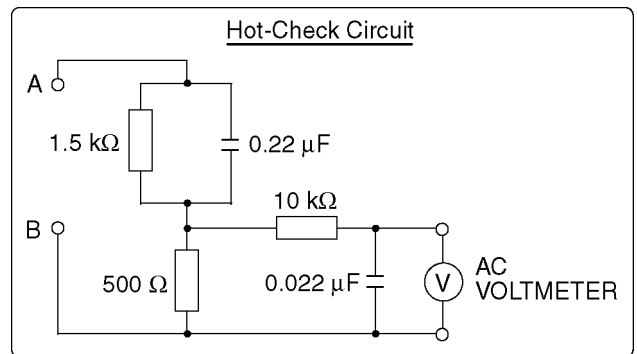

Figure 1

## 2 Warning

### 2.1. Prevention of Electrostatic Discharge (ESD) to Electrostatic Sensitive (ES) Devices

Some semiconductor (solid state) devices can be damaged easily by static electricity. Such components commonly are called Electrostatic Sensitive (ES) Devices. Examples of typical ES devices are integrated circuits and some field-effect transistors and semiconductor “chip” components. The following techniques should be used to help reduce the incidence of component damage caused by electrostatic discharge (ESD).

1. Immediately before handling any semiconductor component or semiconductor-equipped assembly, drain off any ESD on your body by touching a known earth ground. Alternatively, obtain and wear a commercially available discharging ESD wrist strap, which should be removed for potential shock reasons prior to applying power to the unit under test.
2. After removing an electrical assembly equipped with ES devices, place the assembly on a conductive surface such as aluminum foil, to prevent electrostatic charge buildup or exposure of the assembly.
3. Use only a grounded-tip soldering iron to solder or unsolder ES devices.
4. Use only an antistatic solder removal device. Some solder removal devices not classified as “antistatic (ESD protected)” can generate electrical charge sufficient to damage ES devices.
5. Do not use freon-propelled chemicals. These can generate electrical charges sufficient to damage ES devices.
6. Do not remove a replacement ES device from its protective package until immediately before you are ready to install it. (Most replacement ES devices are packaged with leads electrically shorted together by conductive foam, aluminum foil or comparable conductive material).
7. Immediately before removing the protective material from the leads of a replacement ES device, touch the protective material to the chassis or circuit assembly into which the device will be installed.

**CAUTION:**

Be sure no power is applied to the chassis or circuit, and observe all other safety precautions.

8. Minimize bodily motions when handling unpackaged replacement ES devices. (Otherwise harmless motion such as the brushing together of your clothes fabric or the lifting of your foot from a carpeted floor can generate static electricity (ESD) sufficient to damage an ES device).

#### IMPORTANT SAFETY NOTICE

There are special components used in this equipment which are important for safety. These parts are marked by  $\triangle$  in the schematic diagrams, Exploded Views and replacement parts list. It is essential that these critical parts should be replaced with manufacturer's specified parts to prevent shock, fire, or other hazards. Do not modify the original design without permission of manufacturer.

## 2.2. Service caution based on legal restrictions

### 2.2.1. General description about Lead Free Solder (PbF)

The lead free solder has been used in the mounting process of all electrical components on the printed circuit boards used for this equipment in considering the globally environmental conservation.

The normal solder is the alloy of tin (Sn) and lead (Pb). On the other hand, the lead free solder is the alloy mainly consists of tin (Sn), silver (Ag) and Copper (Cu), and the melting point of the lead free solder is higher approx.30 degrees C (86°F) more than that of the normal solder.

#### Definition of PCB Lead Free Solder being used

The letter of "PbF" is printed either foil side or components side on the PCB using the lead free solder. (See right figure)
---

PbF
-----

#### Service caution for repair work using Lead Free Solder (PbF)

- The lead free solder has to be used when repairing the equipment for which the lead free solder is used.  
(Definition: The letter of "PbF" is printed on the PCB using the lead free solder.)
- To put lead free solder, it should be well molten and mixed with the original lead free solder.
- Remove the remaining lead free solder on the PCB cleanly for soldering of the new IC.
- Since the melting point of the lead free solder is higher than that of the normal lead solder, it takes the longer time to melt the lead free solder.
- Use the soldering iron (more than 70W) equipped with the temperature control after setting the temperature at 350±30 degrees C (662±86°F).

#### Recommended Lead Free Solder (Service Parts Route.)

- The following 3 types of lead free solder are available through the service parts route.
  - RFKZ03D01KS------(0.3mm 100g Reel)
  - RFKZ06D01KS------(0.6mm 100g Reel)
  - RFKZ10D01KS------(1.0mm 100g Reel)

#### Note

- \* Ingredient: tin (Sn), 96.5%, silver (Ag) 3.0%, Copper (Cu) 0.5%, Cobalt (Co) / Germanium (Ge) 0.1 to 0.3%

## 2.3. Caution for AC Cord (For EB/GC/SG)

### 2.3.1. Information for your safety

#### IMPORTANT

Your attention is drawn to the fact that recording of pre-recorded tapes or discs or other published or broadcast material may infringe copyright laws.

#### WARNING

To reduce the risk of fire or shock hazard, do not expose this equipment to rain or moisture.

#### CAUTION

To reduce the risk of fire or shock hazard and annoying interference, use the recommended accessories only.

#### FOR YOUR SAFETY

##### DO NOT REMOVE THE OUTER COVER

To prevent electric shock, do not remove the cover. No user serviceable parts inside. Refer servicing to qualified service personnel.

### 2.3.2. Caution for AC mains lead

For your safety, please read the following text carefully.

This appliance is supplied with a moulded three-pin mains plug for your safety and convenience.

A 5-ampere fuse is fitted in this plug.

Should the fuse need to be replaced please ensure that the replacement fuse has a rating of 5 amperes and it is approved by ASTA or BSI to BS1362

Check for the ASRA mark or the BSI mark on the body of the fuse.



If the plug contains a removable fuse cover you must ensure that it is refitted when the fuse is replaced.

If you lose the fuse cover, the plug must not be used until a replacement cover is obtained.

A replacement fuse cover can be purchased from your local Panasonic Dealer.

If the fitted moulded plug is unsuitable for the socket outlet in your home then the fuse should be removed and the plug cut off and disposed of safely.

There is a danger of severe electrical shock if the cut off plug is inserted into any 13-ampere socket.

If a new plug is to be fitted please observe the wiring code as shown below.

If in any doubt, please consult a qualified electrician.

### 2.3.2.1. Important

The wires in this mains lead are coloured in accordance with the following code:

Blue	Neutral
Brown	Live

As the colours of the wires in the mains lead of this appliance may not correspond with the coloured markings identifying the terminals in your plug, proceed as follows:

The wire which is coloured BLUE must be connected to the terminal in the plug which is marked with the letter N or coloured BLACK.

The wire which is coloured BROWN must be connected to the terminal in the plug which is marked with the letter L or coloured RED.

Under no circumstances should either of these wires be connected to the earth terminal of the three pin plug, marked with the letter E or the Earth Symbol.

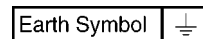

### 2.3.2.2. Before use

remove the Connector Cover as follows.

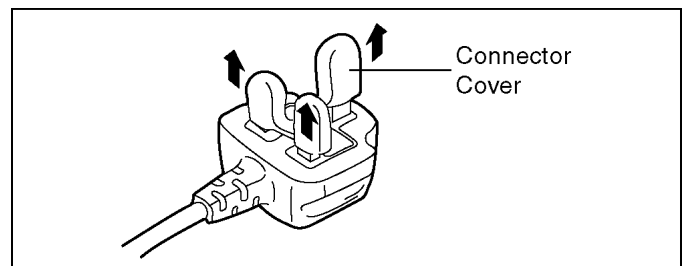

### 2.3.2.3. How to replace the Fuse

1. Remove the Fuse Cover with a screwdriver.

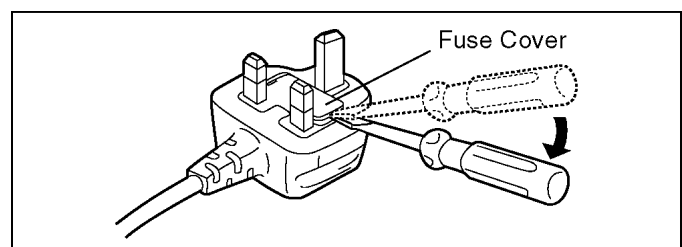

2. Replace the fuse and attach the Fuse cover.

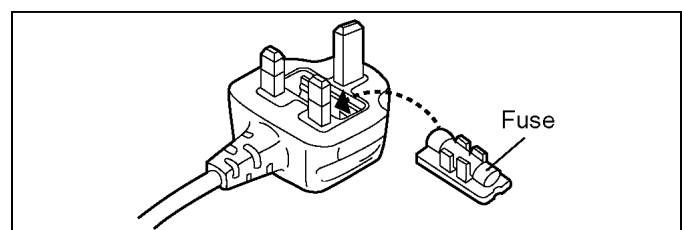

## 2.4. How to Replace the Lithium Battery (PROCEDURE)

1. Remove the Front P.C.B.. (Refer to Disassembly Procedures.)
2. Remove the Lithium Battery "ML-614S/ZT" and then replace the new one. (See Figure B1.)

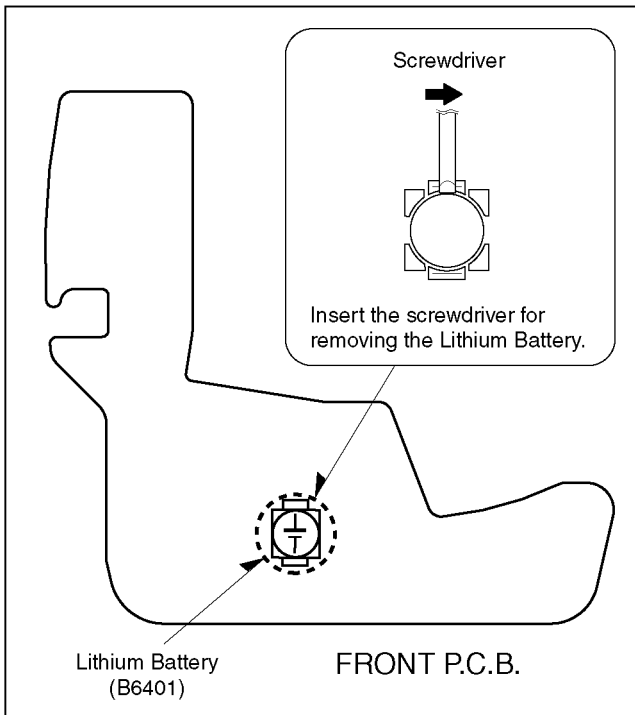

### CAUTION

Danger of explosion if battery is incorrectly replaced.  
Replace only with the same or equivalent type.

### CAUTION

The battery used in this device may present a risk of fire or chemical burn if mistreated.  
Do not recharge, disassemble, heat above 100° C (212 F), or incinerate.  
Replace battery with Panasonic part number ML-614S/ZT only.  
Use of another battery may present a risk of fire or explosion.  
Dispose of used battery promptly.  
Keep away from children.  
Do not disassemble and do not dispose of in fire.

Fig. B1

### Note:

The lithium battery is a critical component. (Type No.: ML-614S/ZT Manufactured by Panasonic.)

It must never be subjected to excessive heat or discharge.

It must therefore only be fitted in equipment designed specifically for its use.

Replacement batteries must be of the same type and manufacture.

They must be fitted in the same manner and location as the original battery, with the correct polarity contacts observed.

Do not attempt to re-charge the old battery or re-use it for any other purpose.

It should be disposed of in waste products destined for burial rather than incineration.

(For English)

**CAUTION**

Danger of explosion if battery is incorrectly replaced.  
Replace only with the same or equivalent type recommended by the equipment manufacturer.  
Discard used batteries according to manufacturer's instructions.

(For French)

**PRECAUTION**

Le fait de remplacer incorrectement la pile peut présenter des risques d'explosion.  
Remplacer la pile uniquement par une pile identique ou de type équivalent recommandée par le fabricant. Se débarrasser des piles usagées conformément aux instructions du fabricant.

(For German)

**VORSICHT**

Bei einer falsch eingesetzten Batterie besteht Explosionsgefahr. Nur mit einer vom gleichen Typ ersetzen.  
Verbrauchte Batterien beim Fachhändler oder einer Sammelstelle für Sonderstoffe abliefern.

(For Swedish)

**VARNING**

Explosionsfara vid felaktigt batteribyte.  
Använd samma batterityp eller en ekvivalent typ som rekommenderas av apparattillverkaren.  
Kassera använt batteri enligt fabrikantens instruktion.

(For Norwegian)

**ADVARSEL!**

Lithiumbatteri-Eksplodingsfare ved feilagtig håndtering.  
Udskiftning må kun ske med batteri af samme fabrikat og type.  
Levér det brugte batteri tilbage til leverandøren.

(For Finnish)

**VAROITUS**

Paristo voi räjähtää, jos se on virheellisesti asennettu.  
Vaihda paristo ainoastaan laitevalmistajan suositteluun tyypin.  
Hävitä käytetty paristo valmistajan ohjeiden mukaisesti.

## 2.5. How to Recycle the Lithium Battery (U.S. Only)

**U.S.A./CANADA CONSUMERS: ATTENTION:**



A lithium ion/polymer battery that is recyclable powers the product you have purchased. Please call 1-800-8-BATTERY for information on how to recycle this battery.



# 3 Service Navigation

## 3.1. Service Information

This service manual contains technical information which will allow service personnel's to understand and service this model. Please place orders using the parts list and not the drawing reference numbers.

If the circuit is changed or modified, this information will be followed by supplement service manual to be filed with original service manual.

### Notes 1:

1. VSK0697 is indicated on AC Adapter used on the following models:  
HDC-HS20P/PC.  
However, the AC Adapter replacement part number is DE-A51BB which should be used when ordering.
2. VSK0698 is indicated on AC Adapter used on the following models:  
HDC-HS20EG/EB/EP/EC/EE/GC/PU/EF/GJ/GN/SG, HDC-HS25EB.  
However, the AC Adapter replacement part number is DE-A51CB which should be used when ordering.
3. VSK0699 is indicated on AC Adapter used on the following model:  
HDC-HS20GK.  
However, the AC Adapter replacement part number is DE-A51DA which should be used when ordering.
4. VSK700 is indicated on AC Adapter used on the following models:  
HDC-HS20GT  
However, the AC Adapter replacement part number is DE-A51EA which should be used when ordering.

### Notes 2:

- 1) This service manual does not contain the following information, because of the impossibility of servicing at component level.
  1. Schematic Diagram, Block Diagram and P.C.B. layout of Main P.C.B. and Sub P.C.B.
  2. Parts List for individual parts of Main P.C.B. and Sub P.C.B.

2) The following category are recycle module part. Please send them to Central Repair Center.

- \*Main P.C.B. (VEP03H65N: HDC-HS20P/PC/PU)
- (VEP03H65Q: HDC-HS20GT)
- (VEP03H65R: HDC-HS20EC/EF/EG)
- (VEP03H65S: HDC-HS20EP)
- (VEP03H65T: HDC-HS20EB)
- (VEP03H65U: HDC-HS20GC/SG)
- (VEP03H65V: HDC-HS20GJ)
- (VEP03H65W: HDC-HS20EE)
- (VEP03H65X: HDC-HS20GN)
- (VEP03H65Y: HDC-HS20GK)
- (VEP03H65AM: HDC-HS25EB)

\*Sub P.C.B. (VEP01A16B: HDC-HS20P/PC/PU/EB/EC/EE/EG/EP/GC/GK/EF/GJ/GN/GT/SG, HDC-HS25EB)

## 3.2. Service Caution

### 3.2.1. How to Discharge the Capacitor on the Sub P.C.B.

Remove the Sub P.C.B.. (Refer to Disassembly Procedures.)

#### CAUTION

Be sure to discharge the capacitor on Jack P.C.B. before disassembling.

#### CAUTION

Be careful of the high voltage circuit on Jack P.C.B. when servicing.

#### Method:

1. Prepare the 2 Resistors (ERG2SJ221:220 ohm/2w) for discharge.

#### Note:

Above 2 Resistors may be substituted with equivalent type.

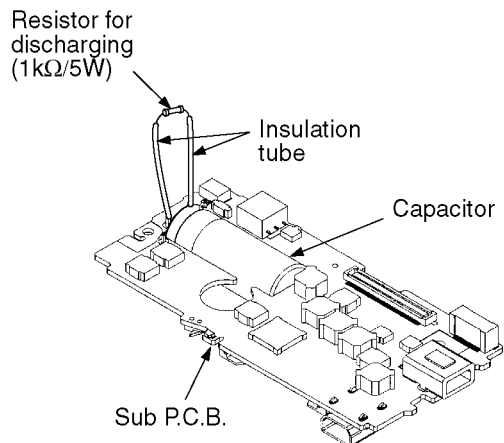

2. Make short circuit using 2 Resistors between C7004(+) and C7004(-) for 3 seconds as follows.
3. After discharging, confirm that the capacitor voltage is sufficiently lowered using a voltmeter



### 3.3. Precautions for Handling HDD



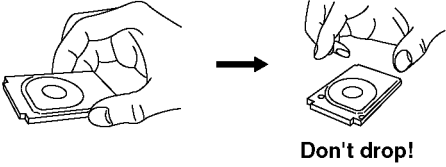

1. Handle HDD very carefully to prevent the static electricity and shock.
2. Set the HDD quickly after taking it out from the package. Make sure to put the HDD on buffer materials, etc.

#### 3.3.1. Precautions at incoming process and for opening packages

Preventing shock	<ul style="list-style-type: none"> <li>• Do not throw down HDD from luggage carrier or avoid dropping accidentally when unloading. The HDD may not be reliable when impacts of dropping, throwing or rolling occur.</li> <li>• Avoid HDD hitting other equipment or other HDD. Hold HDD firmly but do not apply excessive force when taking out from the package because it is particularly slippery.</li> <li>• When taking out HDD from the package, make sure to put buffer materials such as conductive urethane materials on a work table. Also, a stable place is recommended to avoid impacts or vibration.</li> </ul>
Preventing condensation	<ul style="list-style-type: none"> <li>• To prevent dew condensation on HDD due to sharp temperature change, keep it indoors without unpacking, and adjust the package of HDD to room temperature completely before unpacking.</li> <li>• Avoid entrance or window areas where temperature changes easily for storage.</li> </ul>
Holding example	<ul style="list-style-type: none"> <li>• Take out HDD holding both sides, not to press the top cover and the center of the device label.</li> </ul> <div style="text-align: center;"> <p>&lt;OK&gt;</p>  <p><b>Don't drop!</b></p> <p>&lt;NG&gt;</p>  </div>
Preventing static electricity	<ul style="list-style-type: none"> <li>• After opening package, HDD must be handled only by a specified worker in E.S.D.* free environment on a conductive mat. It may cause damage on HDD components due to overvoltage such as electrostatic discharge, etc.</li> </ul>

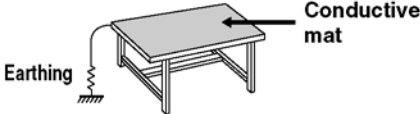
\*E.S.D. = Electrostatically Sensitive Devices

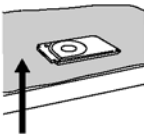
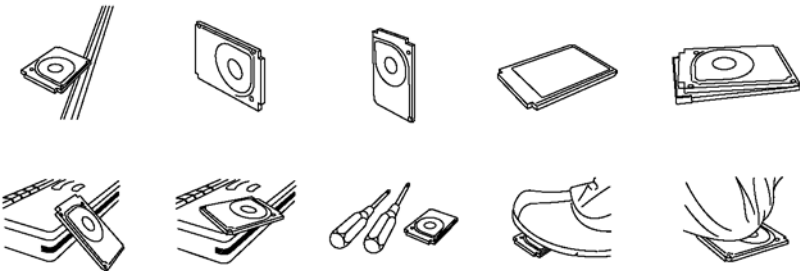
### 3.3.2. Precautions for installing HDD

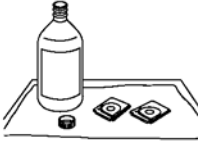
<p>Preventing static electricity</p>	<ul style="list-style-type: none"> <li>HDD may be destroyed by static electricity charged to clothes or human body. Place a conductive mat with removed earthing and use the wrist strap to prevent static charge.</li> </ul> <div style="display: flex; justify-content: space-around; align-items: center;"> <div style="text-align: center;"> <p>&lt;OK&gt;</p>  </div> <div style="text-align: center;"> <p>&lt;OK&gt;</p>  </div> </div>
<p>Preventing shock</p>	<ul style="list-style-type: none"> <li>Place HDD with its face upward (the device label upward) on the flat and stable surface using buffer materials, etc.</li> <li>Do not stand HDD. If it falls down, the excessive impacts may damage HDD.</li> <li>Do not store or carry HDD close to other HDD or other components. The components may be distorted due to impacts or weight, which may result in the performance deterioration of the HDD.</li> <li>Do not put HDD in the working area. Do not put HDD close to industrial tools in particular or temporarily put it on the floor.</li> <li>Be extremely careful not to drop HDD when working on it because even dropping HDD down on the work table with a mat on it may cause damage to HDD.</li> </ul> <div style="display: flex; justify-content: space-around; align-items: center;"> <div style="text-align: center;"> <p>&lt;OK&gt;</p>  <p>Buffer materials</p> </div> <div style="text-align: center;"> <p>&lt;NG&gt;</p>  </div> </div>
<p>No water / solvent</p>	<ul style="list-style-type: none"> <li>Do not hold HDD with a wet hand or put magnets, solvent, tea, coffee, etc, close to HDD. This affects internal components and outside of HDD</li> </ul> <div style="display: flex; justify-content: space-around; align-items: center;"> <div style="text-align: center;"> <p>&lt;NG&gt;</p>  </div> <div style="text-align: center;">  </div> <div style="text-align: center;">  </div> </div>
<p>Connector</p>	<ul style="list-style-type: none"> <li>The interface connector pin is easily damaged. Push it lightly and firmly to the end along the connector guide.</li> <li>For further details, refer to "Precautions for inserting and removing HDD FPC".</li> </ul>

### 3.3.3. Precautions for inserting and removing HDD FPC

Make sure to use the tool (LSVQ0112) when locking and unlocking the lock lever of HDD FPC connector. Do not lock the lock lever without inserting HDD FPC. Otherwise, the connector may be damaged.

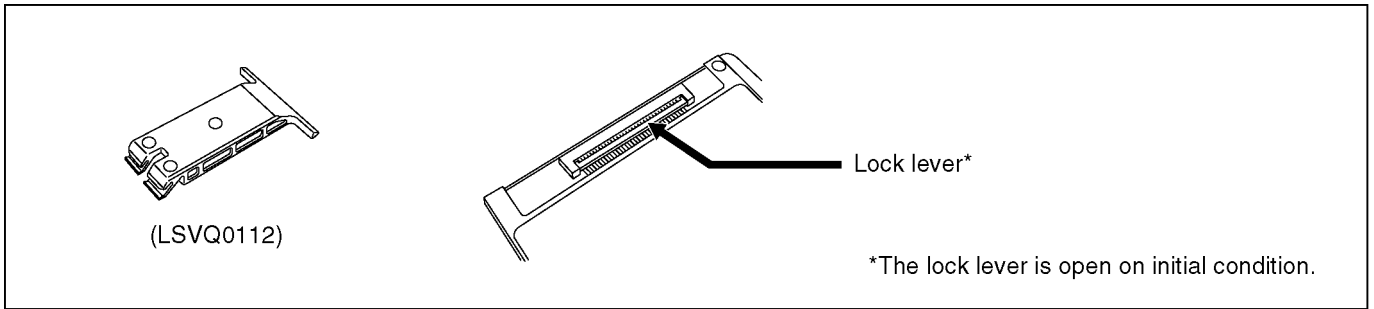

#### Insert HDD FPC

- ① Place HDD so that HDD device label (CAUTION label) faces up.  
**Caution:** Do not set the HDD cushion when installing HDD FPC.
- ② Insert HDD FPC straight to the connector, and make sure if HDD FPC has been inserted to the end.  
**Caution:** The connector surface of HDD FPC must face down and the letter "HDD" and the arrow must be seen as shown.

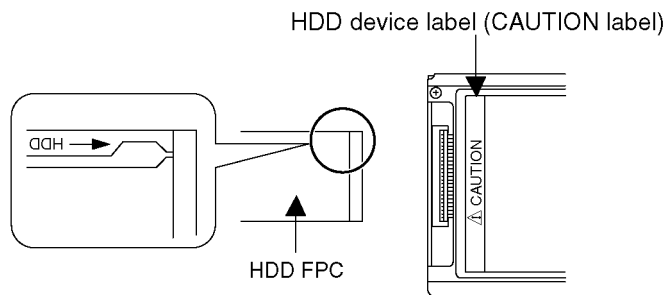

#### Check HDD FPC

Make sure if HDD FPC has been correctly inserted by confirming the FPC pattern boundary line.

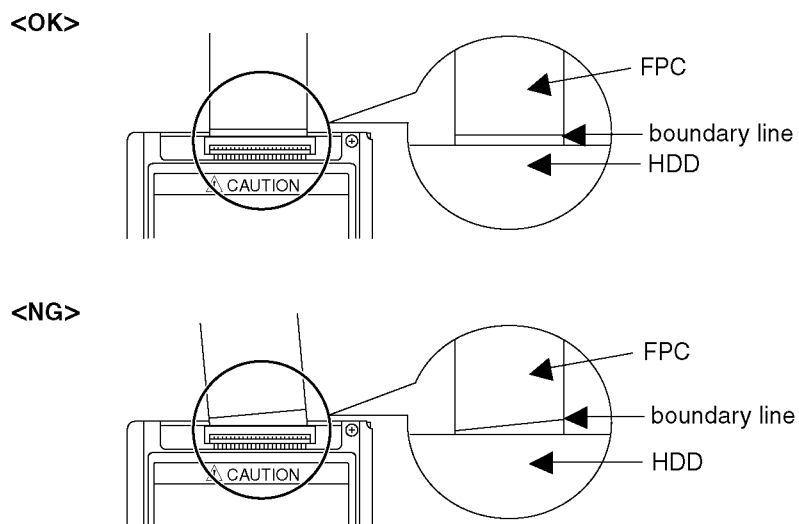

## Tool operation

Lock using the tool after inserting HDD FPC.

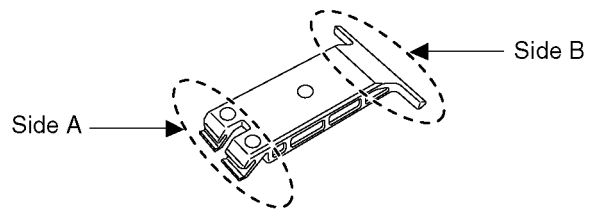

### <How to lock>

After inserting HDD FPC, put the tool (Side B) on the connector and slide it slightly to the direction as shown to lock the lock lever.

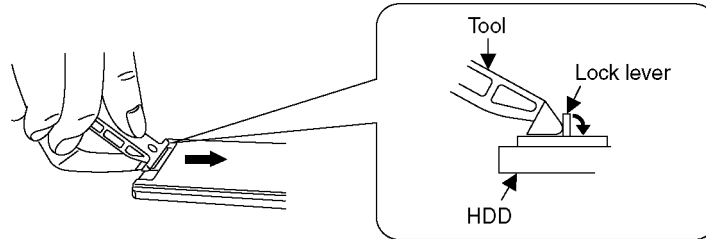

### <How to unlock>

Hook up the tip of the tool (Side A) and unlock the lock lever.  
The angle of the tool must be less than 45 degree.

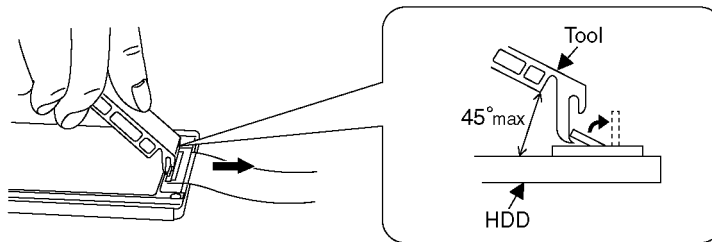



Make sure to use the tool (LSVQ0112) when opening and closing the lock lever.

\*See "Disassembly and Assembly Instructions" (Fig. D10) for attaching to the unit.

## 3.4. Formatting HDD

Please be aware that if a medium is formatted, then all the data recorded on the medium will be erased and cannot be restored. Back up important data on a PC, DVD disc etc.

Change the mode to  or , and select desired media to be formatted.

**Select the menu.**

Formatting SD cards

[SETUP] → [FORMAT CARD] → [YES]

Formatting HDD

[SETUP] → [FORMAT HDD] → [YES]

When the confirmation message appears, touch [YES].

When formatting is complete, touch [EXIT] to exit the message screen.

Perform a physical formatting of HDD when this unit is to be disposed/ transferred.

Do not turn this unit off or remove the SD card, while formatting. Do not expose the unit to vibrations or shock.

**Use this unit to format media.**

**Formatting built-in memory or HDD is only available with this unit.**

**Do not format an SD card using any other equipment such as a PC. The card may not be used on this unit.**

**When disposing of or giving away this unit, note that:**

Formatting and deletion simply change the file management information and cannot be used to completely erase the data in built-in memory or HDD of this unit. The data can be recovered using completely available software or the like.

We recommend that you physically format the built-in memory or HDD before disposing of or giving away this unit.

To physically format the HDD, connect the unit via the AC adaptor, select [FORMAT HDD] → [YES] from the menu, and then press and hold the delete button on the screen below for about 3 seconds. When the HDD data deletion screen appears, select [YES], and then follow the on-screen instructions.

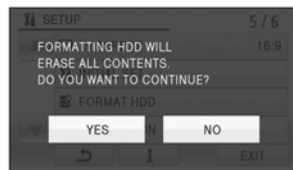

# 4 Specifications

## High Definition Video Camera

ITEM	SPECIFICATION	ITEM	SPECIFICATION
POWER	High Definition Video Camera: Power Source: DC 9.3/7.2 V Power Consumption: 6.6 W (Recording) AC Adaptor: Power Source: AC 110-240 V, 50/60 Hz Power Consumption: 19 W DC Output: DC 9.3 V, 1.2 A (Unit Operation) DC 8.4 V, 0.65 A (Battery Charging)	STILL PICTURES	Recording Media: SD Memory Card: 8 MB /16 MB /32 MB /64 MB /128 MB /256 MB / 512 MB /1 GB/2 GB (FAT12 and FAT16 format corresponding) SDHC Memory Card: 4 GB /6 GB /8 GB /12 GB /16 GB /32 GB (FAT32 format corresponding) HDD : 80 GB Compression: JPEG (Design rule for Camera File system, based on Exif 2.2 standard), DPOF corresponding Picture Size: 1920 × 1080 (16:9)
RECORDING FORMAT	AVCHD format compliant	STANDARD ILLUMINATION	1,400 lx
CAMERA	Filter Diameter: 43.0 mm	MINIMUM REQUIRED ILLUMINATION	Approx. 9 lx (1/30 in Low light mode) Approx. 1 lx with the MagicPix function
	Zoom: 16X optical, 40X/1000X digital		
	Monitor: 2.7-inch wide LCD (approx. 230K pixels)	USB	SD Card Read / write (No copyright protection support) HDD : Read Only Hi-Speed USB (USB 2.0) USB terminal Type Mini AB PictBridge-compliant
	Lens: Auto Iris, F1.8 - F3.3, Focal Length; 2.95 - 47.2 mm Macro (Full Range AF)		
Image Sensor: 1/6-inch 1 MOS Image Sensor	FLASH	Available range: Approx. 1.0 m - 2.5 m (3.3 feet - 8.2 feet)	
VIDEO	AV Terminal Video Output Level : 1.0 Vp-p, 75 ohm, NTSC Colour Signal (HDC-HS20P/PC/PU/GT) 1.0 Vp-p, 75 ohm, PAL Colour Signal (Except HDC-HS20P/PC/PU/GT)	MICROPHONE	5.1ch Surround Microphone (with a zoom microphone function)
	Component Terminal Video Output Level : Y: 1.0 Vp-p, 75 ohm, Pb: 0.7 Vp-p, 75 ohm, Pr: 0.7 Vp-p, 75 ohm	SPEAKER	1 round speaker , Dynamic Type
	HDMI Mini Connector Video Output Level : HDMI™ (x.v.Color™) 1125 i (1080 i) / 525 p (480 p)	OPERATING TEMPERATURE	0°C - 40°C (32°F - 104°F)
AUDIO	AV Terminal Audio Output Level (Line) : 316mV, 600 ohm, 2ch	OPERATING HUMIDITY	10% - 80%
	HDMI Mini Connector Audio Output Level : 5.1ch (AC3) / 2ch (Linear PCM)	WEIGHT	High Definition Video Camera: Approx. 360 g (Approx. 0.794 lbs) (without battery) AC Adaptor: Approx. 115 g (Approx. 0.25 lbs)
MOTION PICTURES	Recording media: SD Memory Card : 1 GB /2 GB (FAT12 and FAT16 format compliant) SDHC Memory Card : 4 GB /6 GB /8 GB /12 GB /16 GB /32 GB (FAT32 format compliant) HDD : 80 GB Compression MPEG-4 AVC / H.264 Recording mode and transfer rate: HA: Approx. 17Mbps (VBR) HG: Approx. 13Mbps (VBR) HX: Approx. 9Mbps (VBR) HE: Approx. 6Mbps (VBR) Recordable Time: Approx.	DIMENSIONS	High Definition Video Camera: (excluding the projecting parts) 64 mm (W) × 69 mm (H) × 128 mm (D) 2.52 inch (W) × 2.72 inch (H) × 5.04 inch (D) AC Adaptor: 92 mm (H) × 33 mm (H) × 61 mm (D) 3.6 inch (W) × 1.3 inch (H) × 2.4 inch (D)
		STANDARD ACCESSORIES	1 pc. AC Adaptor 1 pc. Battery Pack Unit 1 pc. DC Cable 1 pc. AC Cord (Except HDC-HS20GC/SG) 2 pcs. AC Cord (HDC-HS20GC/SG) 1 pc. AV Cable 1 pc. CD-ROM 1 pc. USB Cable 1 pc. Component Cable 1 pc. Remote Controller
		SOLDER	This model use lead free solder (PbF).

	SD Card (1GB)	HDD
HA*1	7 minutes	10 hours 30 minutes
HG*2	9 minutes	13 hours 30 minutes
HX*3	14 minutes	20 hours 30 minutes
HE*4	21 minutes	33 hours 20 minutes

\*1 1920 × 1080: Motion pictures can be recorded with the highest picture quality. \*5

\*2 1920 × 1080: Motion pictures can be recorded with high picture quality.

\*3 1920 × 1080: Motion pictures can be recorded with normal picture quality.

\*4 1440 × 1080: Motion pictures can be recorded for a longer time.

\*5 This means the highest quality for this unit.

Picture Size

HA/HG: 1920 × 1080/ 60i, 1920 × 1080/ 24p

HX: 1920 × 1080/ 60i

HE: 1440 × 1080/ 60i

Audio Compression:

Dolby Digital (Dolby AC3) / 5.1 ch)

Weight and dimensions are approximate values. Specifications may change without prior notice.



# 5 Location of Controls and Components

Followings are the Location of Controls and Components for HDC-TM20P/PC as a sample. For other models, refer to each Operating Instructions.

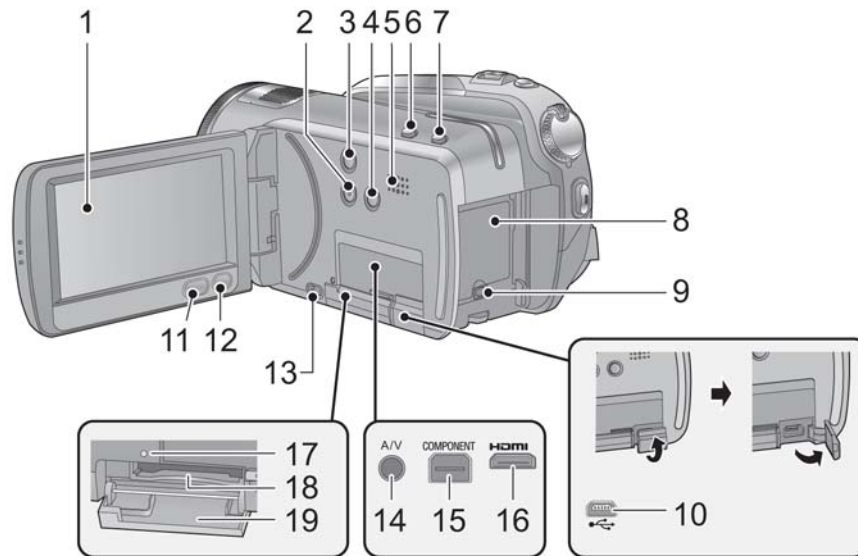

**1 LCD monitor (Touch screen)**



- It can open up to 90°.

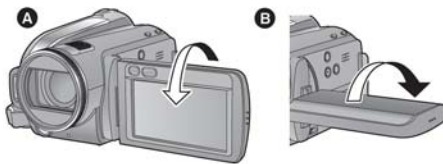

- It can rotate up to 180° **A** towards the lens or 90° **B** towards the opposite direction.

Due to limitations in LCD production technology, there may be some tiny bright or dark spots on the LCD monitor screen. However, this is not a malfunction and does not affect the recorded picture.

- 2 Manual button [MANUAL]**
- 3 Optical image stabilizer button [(i)], O.I.S.]**
- 4 Light button [LIGHT]**

- 5 Speaker**
- 6 Intelligent auto button [iA]**
- 7 PRE-REC button [PRE-REC]**
- 8 Battery holder**
- 9 DC input terminal [DC IN]**
  - Always use the supplied AC adaptor or a genuine Panasonic AC adaptor (VW-AD21PP; optional).
- 10 USB terminal [↔]**
- 11 Menu button [MENU]**
- 12 Delete button [🗑️]**
- 13 SD card open lever [OPEN]**
- 14 Audio-video output terminal [A/V]**
  - Use the AV cable (only the supplied cable).
- 15 Component terminal [COMPONENT]**
- 16 HDMI mini connector [HDMI]**
- 17 Access lamp [ACCESS]**
- 18 Card slot**
- 19 SD card cover**

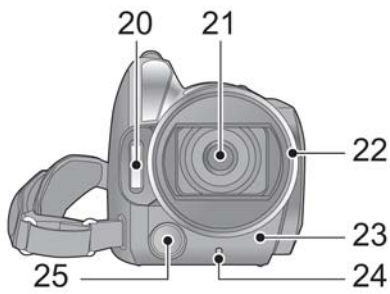

- 20 Built-in flash
- 21 Lens (LEICA DICOMAR)

**Lens cover A**



• The lens cover opens in recording mode.

**22 Lens hood**

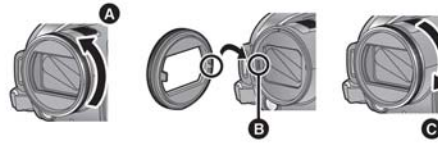

Rotate the lens hood counter-clockwise **A** to remove it. In order to attach it, place into slot **B**, and then rotate it clockwise **C**.

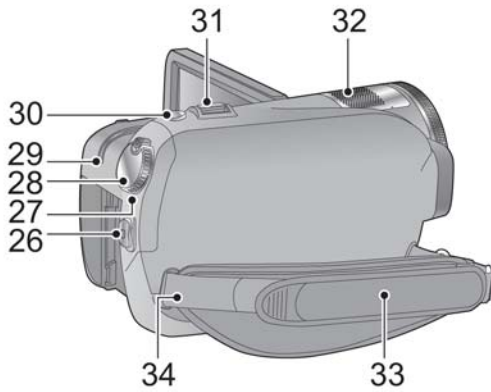

- When fitting the tele conversion lens (VW-T4314H; optional) or the wide conversion lens (VW-W4307H; optional), first remove the lens hood.

- 23 Remote control sensor
- 24 Recording lamp
- 25 Video light



- 26 Recording start/stop button
- 27 Status indicator
- 28 Mode dial
- 29 HDD access lamp [ACCESS HDD]
- 30 Photoshot button [  ]
- 31 Zoom lever [W/T] (In recording mode)  
Thumbnail display switch/Volume lever [-  /VOL+] (In playback mode)
- 32 Internal microphones (5.1 channel support)

### 33 Grip belt

Adjust the length of the grip belt so that it fits your hand.

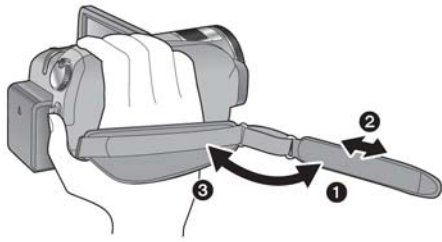

- 1 Flip the belt.
- 2 Adjust the length.
- 3 Replace the belt.

### 34 Shoulder strap fixture

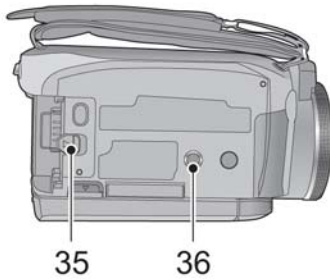

### 35 Battery release lever [BATT] (→ 24)

### 36 Tripod receptacle

This is a hole for attaching the unit to the optional tripod. (For details on mounting the tripod, refer to the operating instructions for the tripod.)

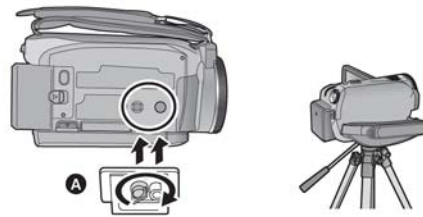



A Camera base

Be sure that the grip belt stays clear of the video light B when the tripod is used as shown below.



## Selecting a mode (Turning the unit on/off)

Change the mode to recording, playback or power OFF.

Turn on the power by changing the mode to  or  while pressing the lock release button **A**.

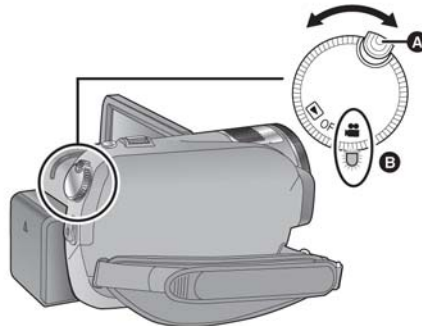



- Rotate the mode dial while at the same time pressing in the lock release button if changing from OFF to another mode.
- Align with the status indicator **B**.

The status indicator lights.

### **To turn off the power**

Change the mode to OFF.

The status indicator **B** goes off.

	Recording mode
	Playback mode
OFF	

# Using with the remote control

## Select the menu.

[SETUP] → [REMOTE CONTROL] → [ON]

- This function's default setting is [ON].
- [REMOTE CONTROL] can be set to [OFF] so the remote control will not be mistakenly used when not in use.

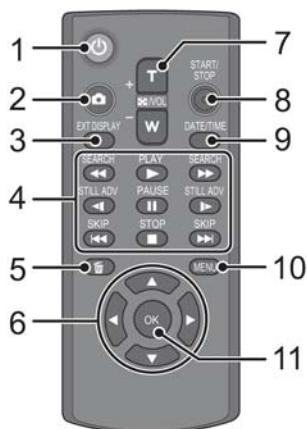

- 1 Power on/off button [ ⏻ ]**  
Power can be turned on/off when the mode is set to anything but OFF.
  - Power cannot be turned on by the power on/off button when 36 hours have passed after the power is turned off.
  - Power cannot be turned off when it is connected to the PC or the DVD burner.
- 2 Photoshot button [ 📷 ]\***
- 3 On-screen display button [EXT DISPLAY]**
- 4 Playback operation buttons**  
These buttons function in the same manner as the corresponding playback operation icon being displayed on screen.  
[Excluding skip playback].
- 5 Delete button [ 🗑️ ]\***
- 6 Direction buttons [ ▲, ▼, ◀, ▶ ]**
- 7 Zoom/volume/thumbnail display switch buttons [ T, W, 📺 /VOL ]\***
- 8 Recording start/stop button [START/STOP]\***

9 Date/time button [DATE/TIME]

10 Menu button [MENU]\*

11 OK button [OK]

\* means that these buttons function in the same manner as the corresponding buttons on the unit.

## CAUTION

Danger of explosion if battery is incorrectly replaced. Replace only with the same or equivalent type recommended by the manufacturer. Dispose of used batteries according to the manufacturer's instructions.

Remove the insulation sheet **A** before using.



## Replace a button-type battery

- 1 While pressing the stopper **B**, pull out the battery holder.**

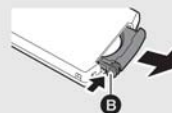

- 2 Set the button-type battery with its (+) mark facing upward and then put the battery holder back in place.**

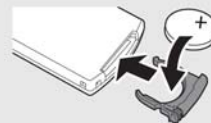

- When the button-type battery runs down, replace it with a new battery (part number: CR2025). The battery should normally last about 1 year, however this depends on how frequently the unit is used.
- Keep the button-type battery out of reach of children to prevent swallowing.

# 6 Service Mode

## 6.1. Service Menu

When abnormal detection contents are confirmed, do the following operation. Automatic diagnosis code will be displayed. (Service Menu)

### To enter the Service Menu

1. Turn the Power on and set the Mode Dial to [VIDEO RECORDING MODE].
2. Push the [OIS], [MENU] and [iA] simultaneously for 3 seconds (with no SD Card inserted).

### Note:

If a SD Card is inserted, the above operation will not work.

This operation displays the following Service Menu items.

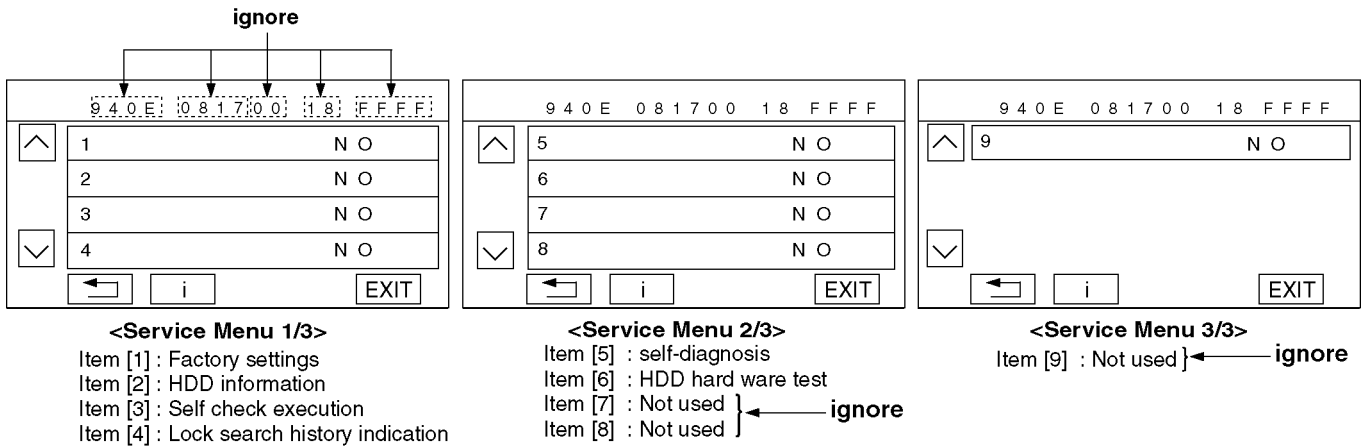

Fig. 1-1

### Note:

Only perform items 1, 2, 3, 4, 5 and 6 in the Service Menu.

**To select the Item of Service Menu**

1. Press [TOUCH PANEL icon] to select item [1], [2], [3], [4], [5] and [6].
2. Press [TOUCH PANEL icon] to display [YES/NO] screen.
3. Press [TOUCH PANEL icon] to select [YES].
4. Press [TOUCH PANEL BAK] to end.

**<Item [2] screen : HDD information (1/10 screen)>**

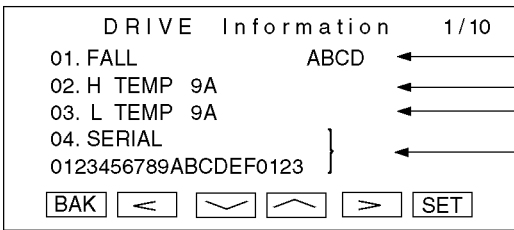

- 01. Number of times of fall detection (Base 16 number)
- 02. Number of times of shut down due to high temperature (Base 16 number)
- 03. Number of times of shut down due to low temperature (Base 16 number)
- ignore

**<Item [2] screen : HDD information (4/10 screen)>**

Press [TOUCH PANEL CONTROL RIGHT >] to display 4/10 screen.

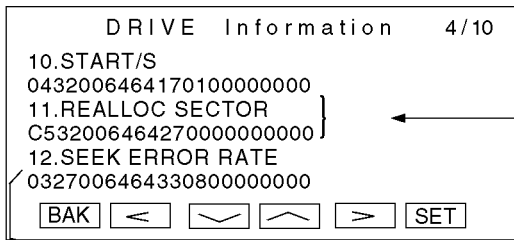

Re-allocated Sector Count (Quantity)

For example :

ignore      A   B   C   D   E   F  
 C532006464270000000000

↓ Sorting

F   E   D   C   B   A  
 0000000000027  
 (Base 16 number)

Change to decimal number

→ 39 (Re-allocated Sector Count)

- If Re-allocated Sector Count is 500 and over, replace HDD.

Fig. 1-2

**<Item [2] screen : HDD information (7/10 screen)>**

Press [TOUCH PANEL CONTROL RIGHT >] to display 7/10 screen.

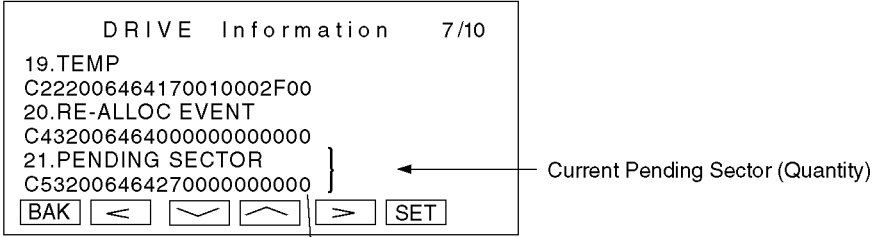

For example :

ignore A B C D E F  
 C 5 3 2 0 0 6 4 6 4 2 7 0 0 0 0 0 0 0 0 0 0 0

Sorting

F E D C B A  
 0 0 0 0 0 0 0 0 0 0 0 2 7  
 (Base 16 number)

Change to decimal number

39 (Current Pending Sector)

- If Current Pending Sector is 500 and over, replace HDD.

**<Item [2] screen : HDD information (8/10 screen)>**

Press [TOUCH PANEL CONTROL RIGHT >] to display 8/10 screen.

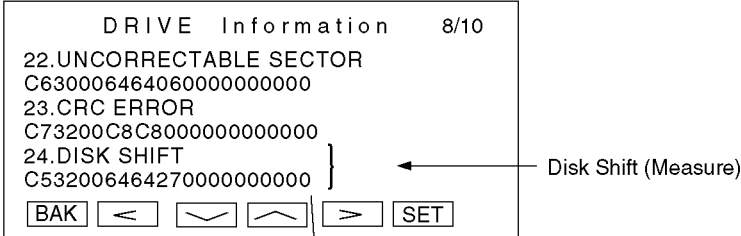

For example :

ignore A B C D E F  
 C 5 3 2 0 0 6 4 6 4 2 7 0 0 0 0 0 0 0 0 0 0 0

Sorting

F E D C B A  
 0 0 0 0 0 0 0 0 0 0 0 2 7  
 (Base 16 number)

Change to decimal number

39 (Disk Shift)

- If Disk Shift is 400 and over, replace HDD.

Fig. 1-3



<Item [3] screen : HDD Self check>

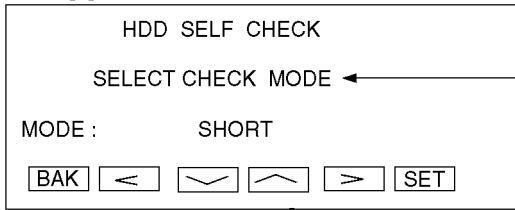

HDD self check mode "SHORT or EXTEND" is selectable by [TOUCH PANEL CONTROL RIGHT > & LEFT < ]. However, execute only "SHORT" mode. (Ignore EXTEND mode.)

Select "SHORT" then press [TOUCH PANEL SET icon].

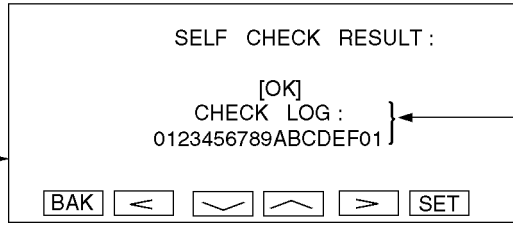
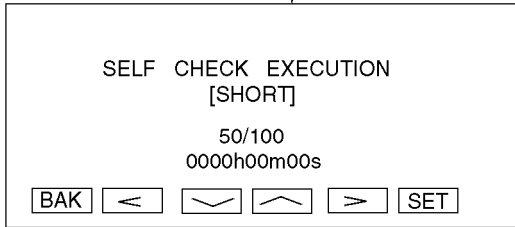

(Execution time: 3 or 4 minutes)

- If "SELF CHECK RESULT" is [NG] or [COMMAND NG] in SHORT check mode, replace HDD.

<Item [4] screen : Lock search history indication>

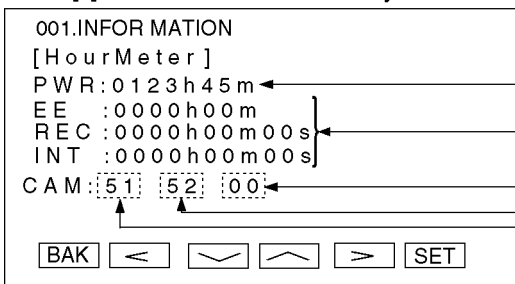

Total elapsed power on time

ignore

The number before previous  
Previous number  
Latest number

Camera Error record

Camera Error code record in hexadecimal

Display	Explanation of cause
00	No error
33	Communication error between CAMERA and ARM
51	Focus Motor Lock
52	Zoom Motor Lock
53	OIS Drive Error
71	Lens cover open / close is abnormal
72	Cooling fan is abnormal
73	High temperature is abnormal

Fig. 1-4

<Item [5] screen : self-diagnosis>

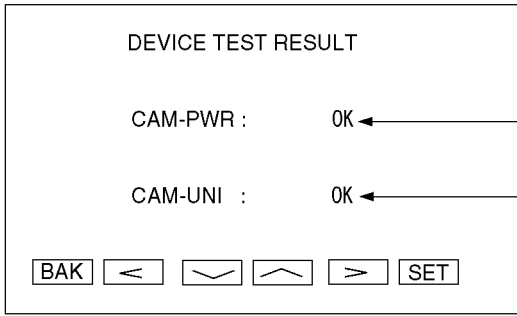

About this function

This function displays the result of self-diagnosis (to diagnose whether the interface of and between devices works or not) performed when the power is turned on.

CAM-PWR:

Result of communication test between Power Management IC and camera-microcomputer

CAM-UNI:

Result of communication test between Uniphier and camera-microcomputer

<Item [6] screen : HDD Hardware test>

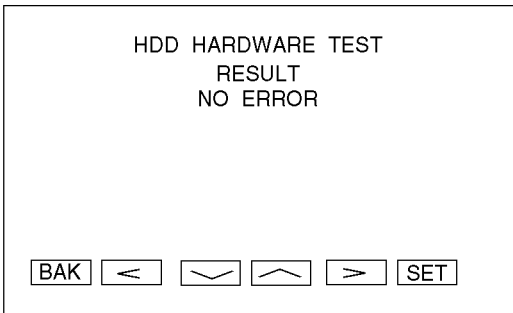

HDD HARDWARE TEST RESULT
NO ERROR
CTR ERROR
BUFF RAM ERROR
ECC DEV ERROR
CPU ERROR
COMMAND ERROR

} Replace HDD

- Replace HDD when "HDD HARDWARE TEST RESULT" is other than [NO ERROR].

Fig. 1-5

## 6.2. About Default Setting

The data of Menu, Mode, Card and EEPROM setting, etc. is set to the default condition in factory.

### 6.2.1. How to set the Default Setting

1. Turn the Power on and set the Mode Dial to [RECORDING MODE].
2. When pressing [MENU], [MANUAL] and [iA] for more than 3 seconds until the top screen of the Service Menu being displayed.
3. Item [1] is selected with the [TOUCH SCREEN] icon.
4. [YES] is selected with the [TOUCH SCREEN] icon.
5. After few seconds "END" is displayed on LCD monitor. Cutting of battery connection or AC power supply connection as a completion of the "FACTORY SETTINGS."

The Default Settings clean up and/or refresh the following settings.

1. Menu, Mode, Adjusted Value
2. Card format
3. Reset of picture files and directory number (Set the picture record file number to 1)
4. Clear the information of Mechanism Lock
5. Set the time setting to no-setting

The Setting position of Default Settings:

Name	Setting Position
Mode dial	OFF

## 7 Service Fixture & Tools

### 7.1. Service Tools and Equipment

Parts Name	Parts No.	Q'ty	Remarks
PC	---	1	
AC Adaptor	---	1	
DC Cable	---	1	
AV Multi Cable	---	1	
USB Cable	---	1	
PC-Adjustment Program	---	1	
Light Box	VFK1164LBX1	1	
Infinity Lens	VFK1164TCM02	1	With Focus Chart
Color Bar Chart	VFK1164TFCB2	1	
Gray Scale Chart	VFK1164TFGS2	1	
Color Conversion	VFK1164TFCT2	1	
Light Box	VFK1164TDVLB	1	
Color Conversion (C12)	VFK1164LBB12	1	
Color Conversion (C2)	VFK1164LBB2	1	
Color Conversion (C4)	VFK1164LBB4	1	
Color Conversion (C8)	VFK1164LBB8	1	
43mm Ring	VFK1164TAR43	1	
Infinity Lens	VFK1164TCM02	1	With Focus Chart
Infinity Lens	RFKZ0422	1	
Tripod	VFK1164TST	1	
Tripod	RFKZ0333B	1	
Adapter for infinity Lens	RFKZ0333H	1	
Extension Flat Cable (33pin)	RFKZ0448	1	FP6003 (Main) - FP6403 (FRONT P.C.B.)
Extension Flat Cable (40pin)	RFKZ0379	1	PS6003 (Main) - Side (R) FPC Unit
Extension Flat Cable (16pin)	VFK1582A1620	1	FP6006 (Main) - Top/Operation Unit
Extension Flat Cable (33pin)	RFKZ0448	1	FP6002 (Main) - Lens Unit
Extension Flat Cable (27pin)	VFK1491	1	FP6001 (Main) - MOS Unit
Extension Flat Cable (40pin)	RFKZ0379	1	PP6001 (Main) - HDD Unit
Extension Flat Cable (24pin)	VFK1938	1	PS6101 (Sub) - Battery Case Unit

# 8 Disassembly and Assembly Instructions

## 8.1. Disassembly Flow Chart

This flow chart indicates the disassembly steps the cabinet parts and P.C.B.. Unit in order to access to be serviced. When reinstalling, perform the steps in the reverse order.

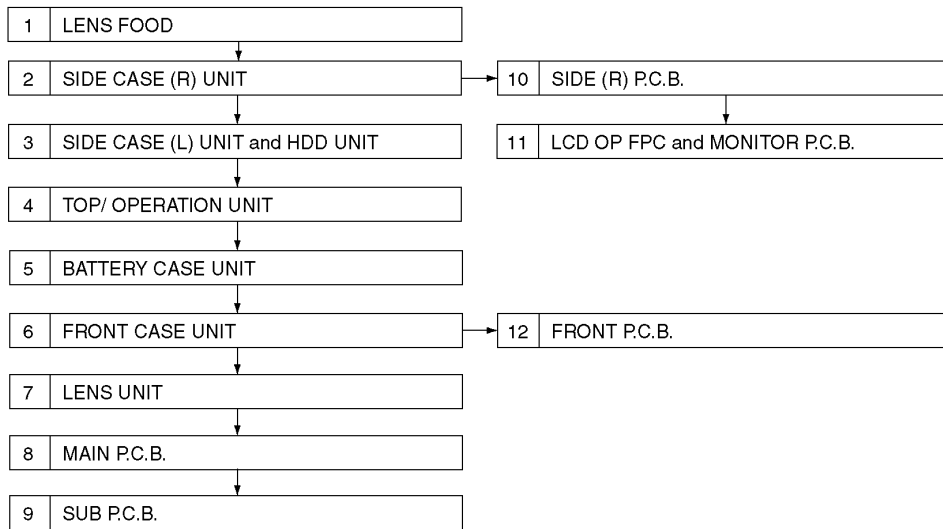

## 8.2. P.C.B. Layout

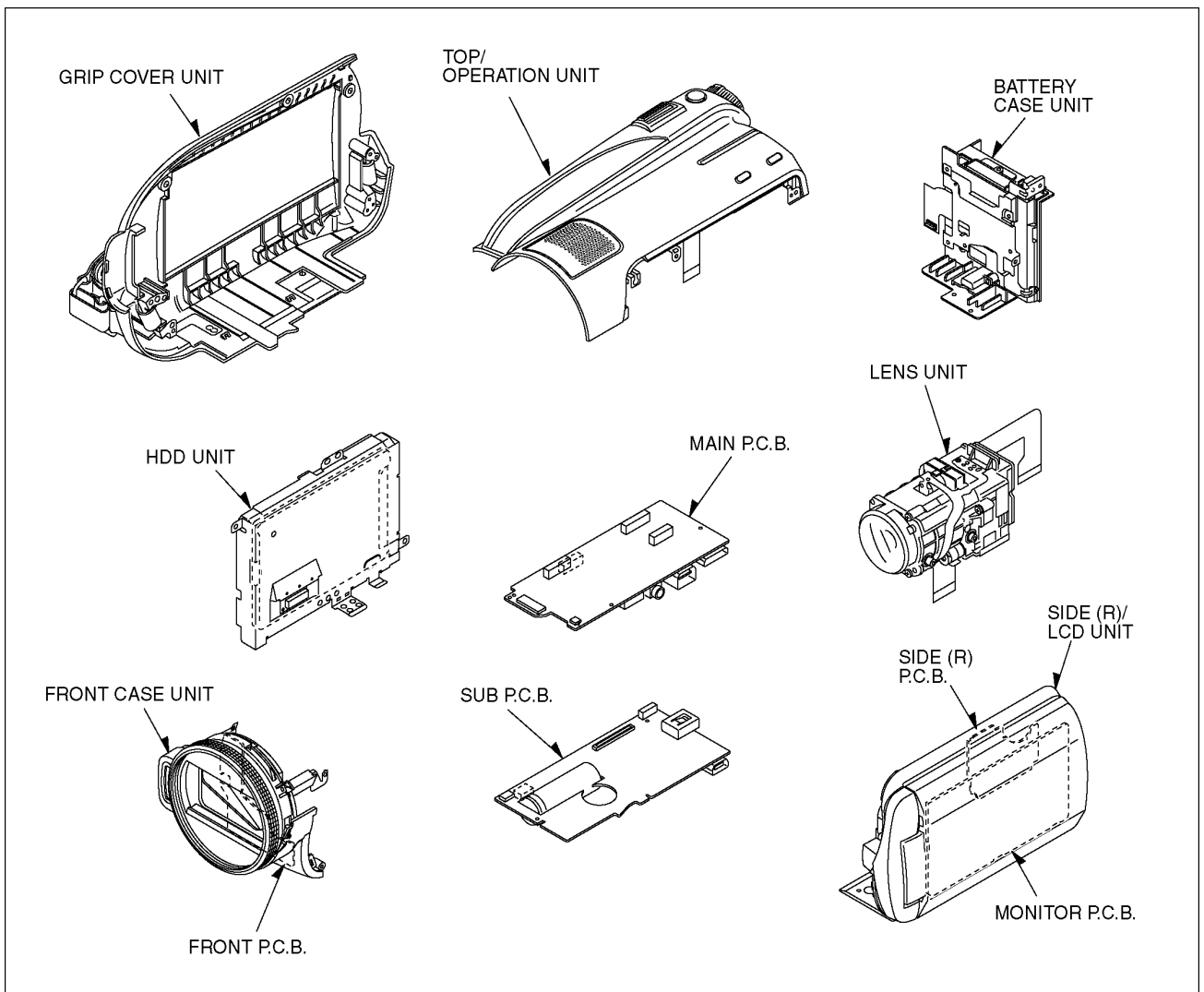

Fig. F1

### 8.3. Disassembly Procedures

Flow-Chart for Disassembly Procedure

No.	Item / Part	Fig.	Removal (Screw,Connector,FPC.& Other)
1	Lens Hood	Fig. D2	Lens Hood
2	Side Case (R) Unit	Fig. D3	4 Screws (A)
		Fig. D4	2 Screws (A) 3 Screws (B) 1 Screw (C) SR Cover
		Fig. D5	3 Screws (A) 1 Screw (B) 1 Screw (D) PS6003 (Flex) Side Case (R) Unit
3	Side Case (L) Unit, HDD, HDD Frame	Fig. D6	2 Screws (E)
		Fig. D7	2 Screws (F)
		Fig. D8	1 Screw (G) 3 Screws (H) 2 Locking tabs Side Case (L) Unit
		Fig. D9	PP6001 (Connector) HDD Unit HDD Cushion HDD FPC HDD Shield Frame 2 Screws (I)
		Fig. D10	Note for replacing HDD 1)How to Remove
		Fig. D11	Note for replacing HDD 2)How to Attach HDD Unit HDD Cushion HDD FPC
4	Top/ Operation Unit	Fig. D12	FP4801 (Flex) FP6006 (Flex) 1 Screw (J) 1 Screw (K) Top/ Operation Unit
5	Battery Case Unit	Fig. D13	1 Screw (L) PS6101 (Connector) Battery Case Unit
6	Front Case Unit	Fig. D14	1 Screw (M)
		Fig. D15	FP6403 (Flex) P6101 (Connector) P6102 (Connector) Front Case Unit
7	Lens Unit	Fig. D16	2 Screws (N) FP6001 (Flex) FP6002 (Flex)
		Fig. D17	1 Screw (O) Lens Frame Unit Lens Unit
8	Main P.C.B.	Fig. D18	3 Screws (P) PS6004 (Connector) Main P.C.B.
9	Sub P.C.B.	Fig. D19	2 Screws (Q) Main Frame Bottom Frame Main-Sub FPC Sub P.C.B.

No.	Item / Part	Fig.	Removal (Screw,Connector,FPC.& Other)
10	Side (R) P.C.B.	Fig. D20	2 Screws (R) P6501 (Connector) Speaker Angle Speaker
		Fig. D21	2 Screws (S) FP6501 (Flex) FP6502 (Flex) FP6503 (Flex) Side (R) FPC Unit Side (R) P.C.B.
11	LCD OP FPC, Monitor P.C.B.	Fig. D22	Turn the LCD Case to the arrow direction so that the screws can be seen, and remove the 2 screws (T). 2 Screws (T)
		Fig. D23	6 Locking tabs FP902 (Flex) FP903 (Flex) LCD Case (T) Unit
		Fig. D24	2 Screws (U) FP905 (Flex) LCD OP Angle LCD OP Button LCD OP FPC 2 Locking tabs
		Fig. D25	FP903 (Flex) FP904 (Flex) Light Guide Plate Reflection Sheet Monitor P.C.B.
12	Front P.C.B.	Fig. D26	2 Screws (V) FP6400 (Flex) LED Light Lens Front P.C.B.

**NOTE:**

When servicing and reassembling, remove the card and battery from the unit.

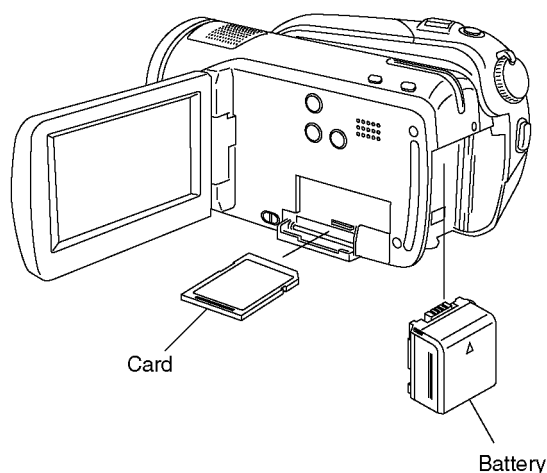

Fig. D1

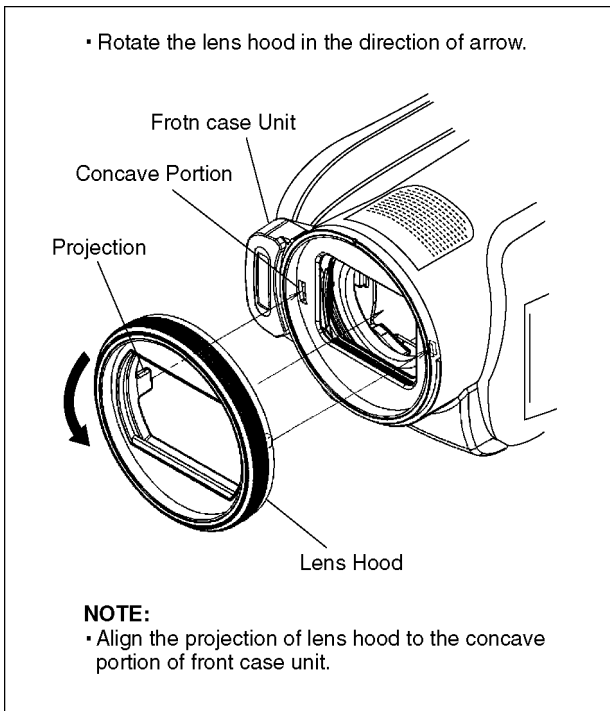

Fig. D2

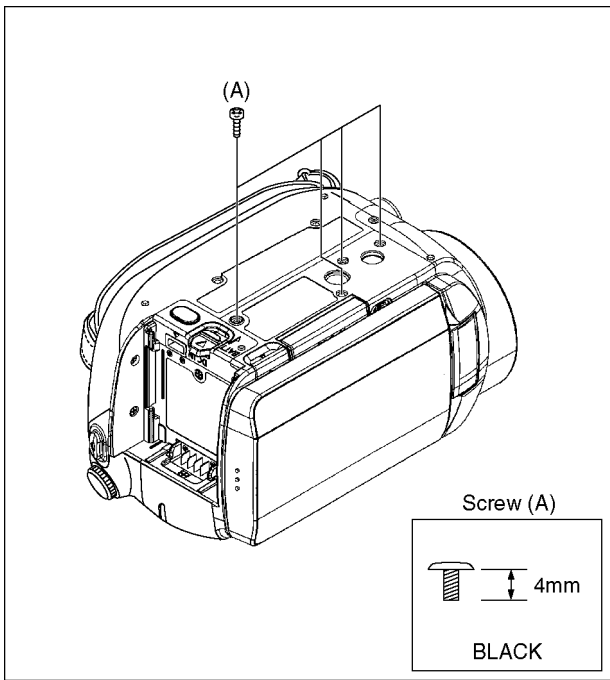

Fig. D3

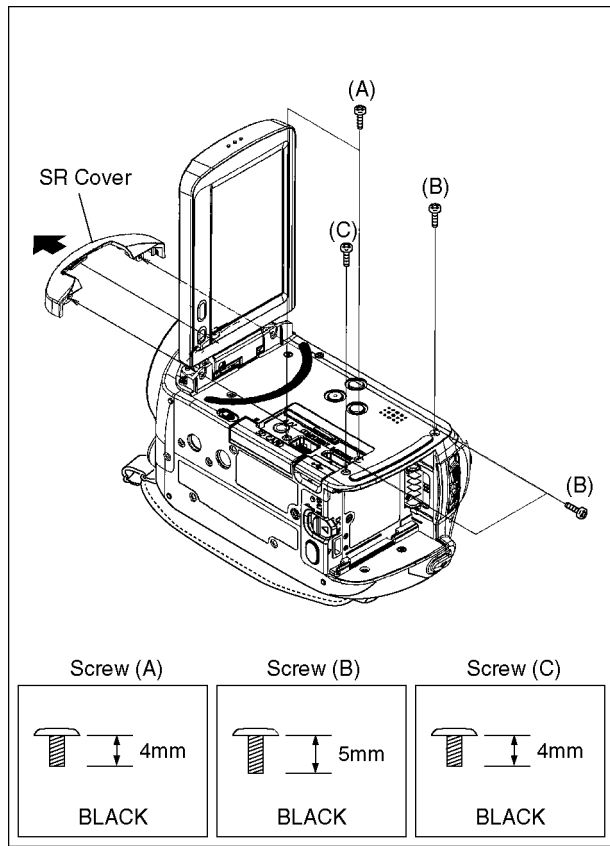

Fig. D4

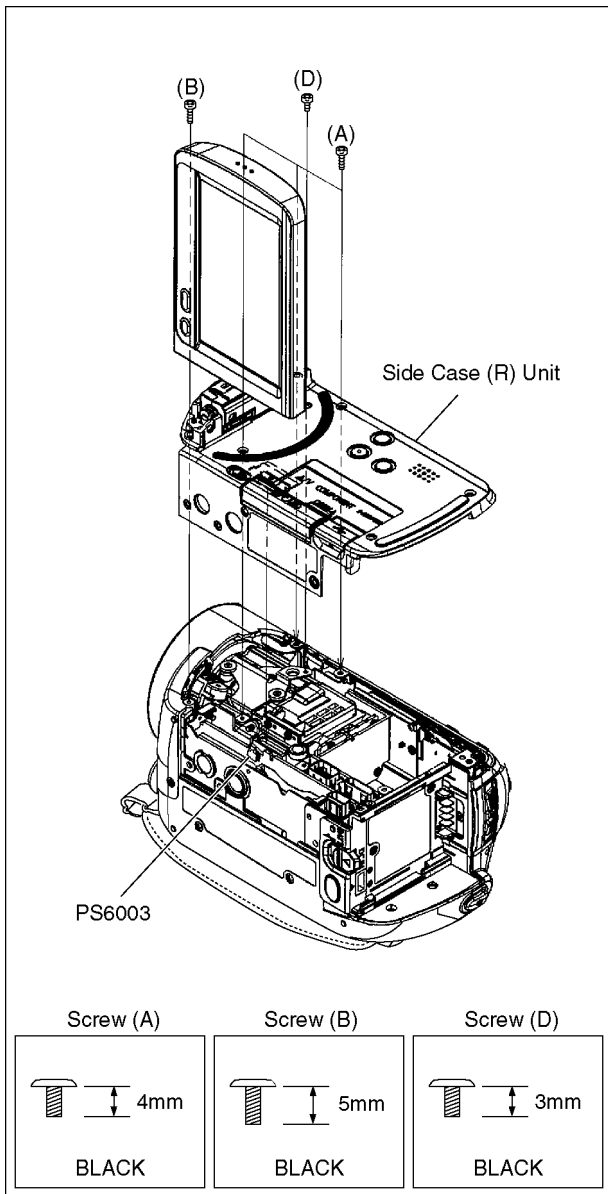

Fig. D5

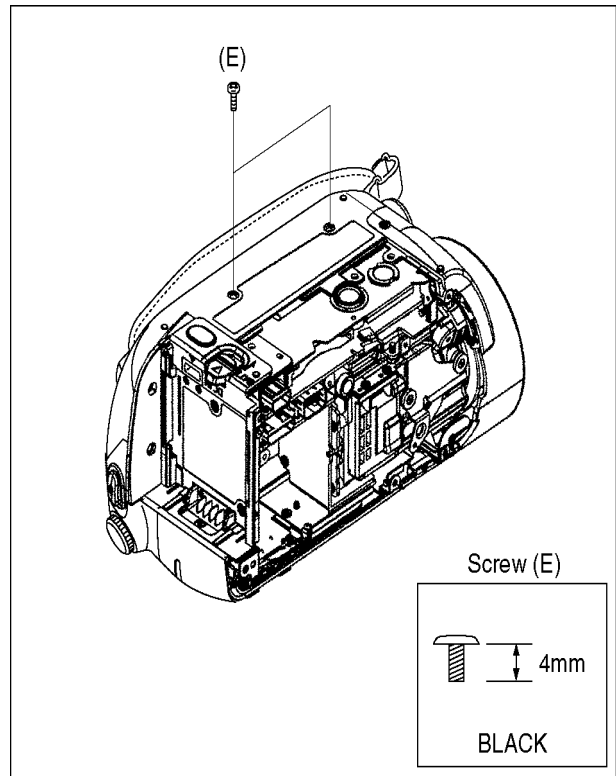

Fig. D6

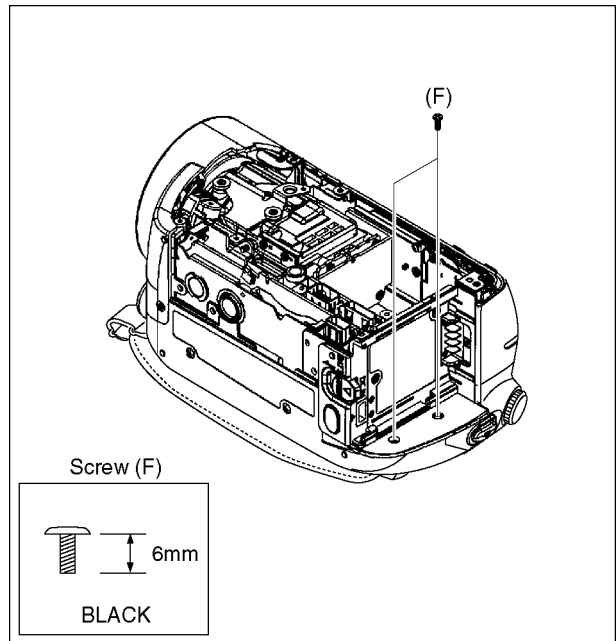

Fig. D7



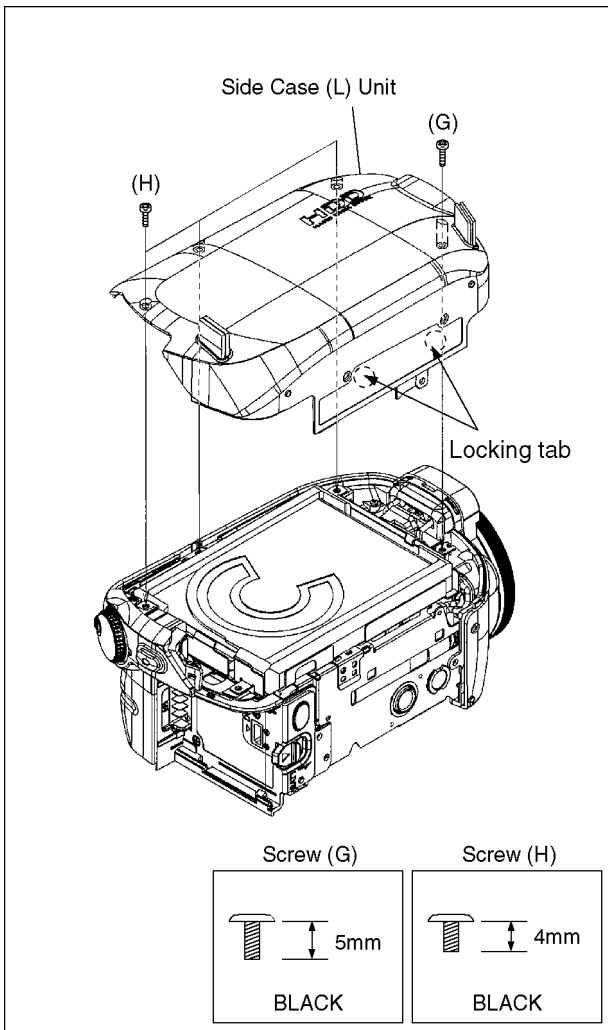

Fig. D8

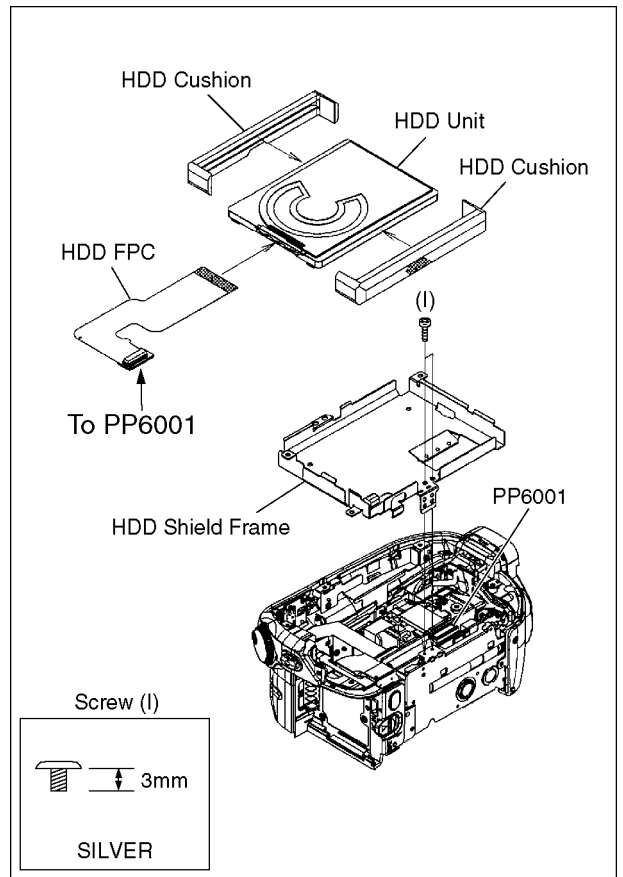

Fig. D9

### Note for replacing HDD

- Be sure to use the tool when inserting and removing HDD FPC.

After replacing the HDD, be sure to format the new HDD.  
See "FormattingHDD" in Service Navigation.

### 1) How to Remove

- ① Remove the HDD cushion from the HDD.
- ② Remove the HDD FPC from HDD using the tool.

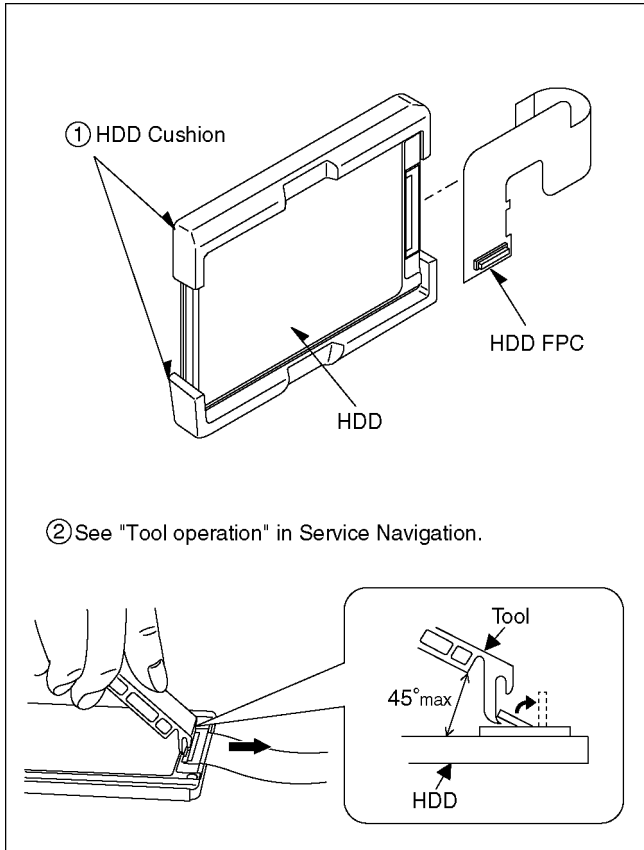

Fig. D10

### 2) How to Attach

- ① Attach the HDD FPC to the new HDD using the tool.
- ② Attach the HDD cushion to the HDD.

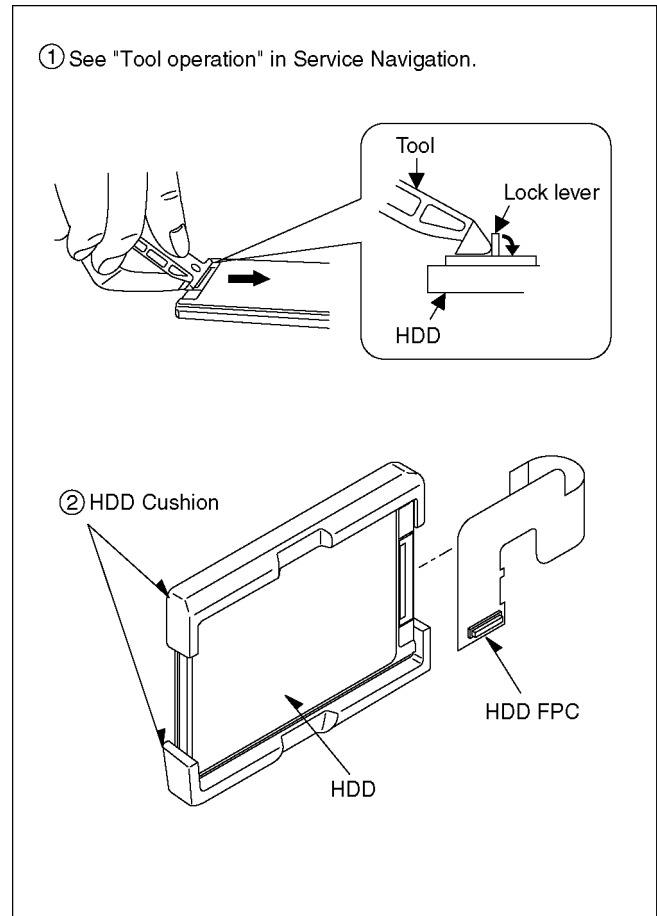

Fig. D11

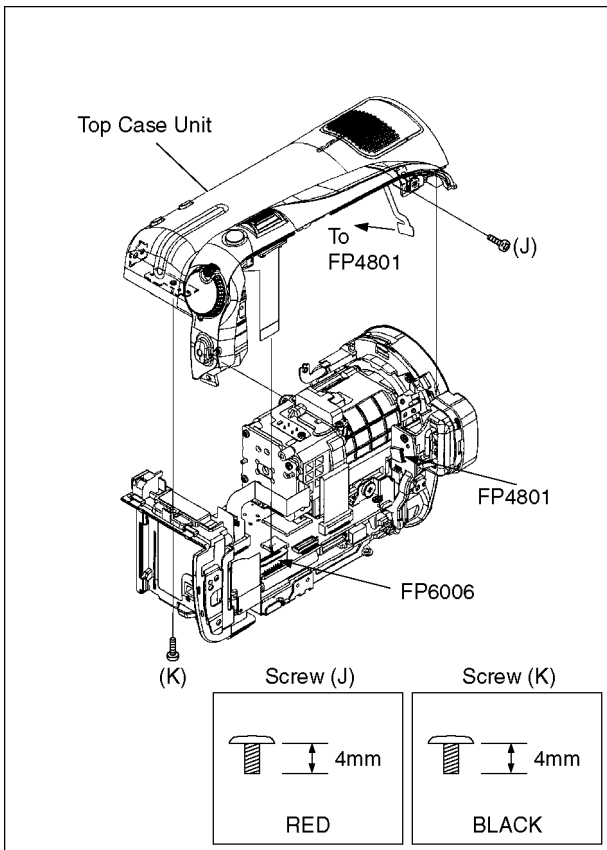

Fig. D12

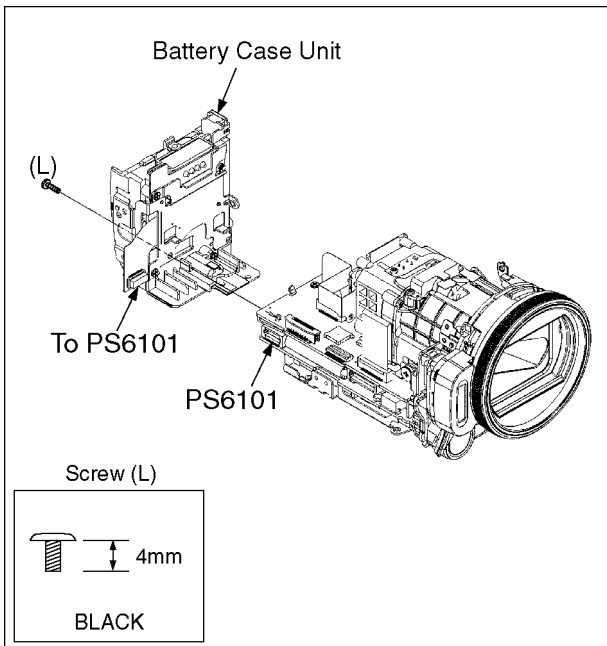

Fig. D13

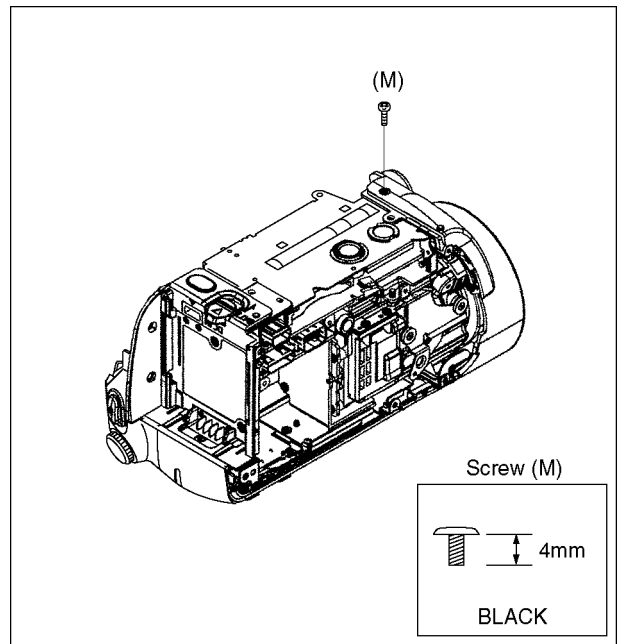

Fig. D14

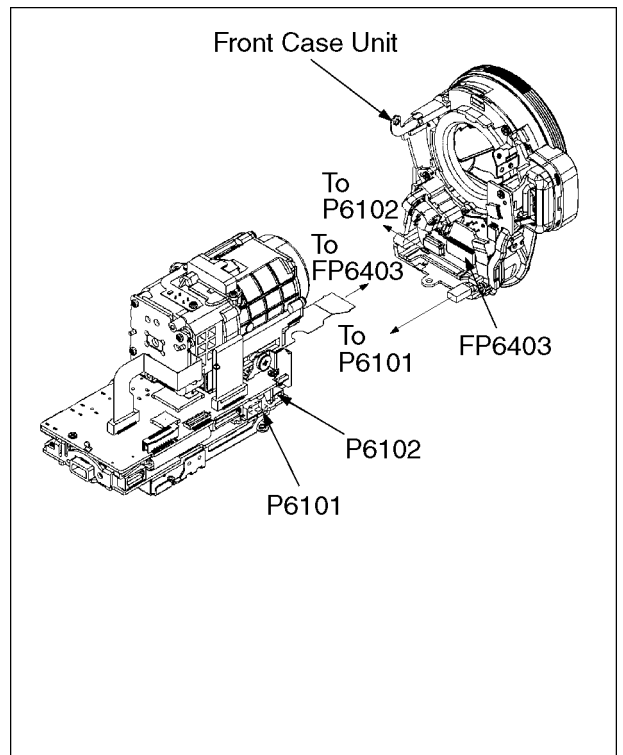

Fig. D15

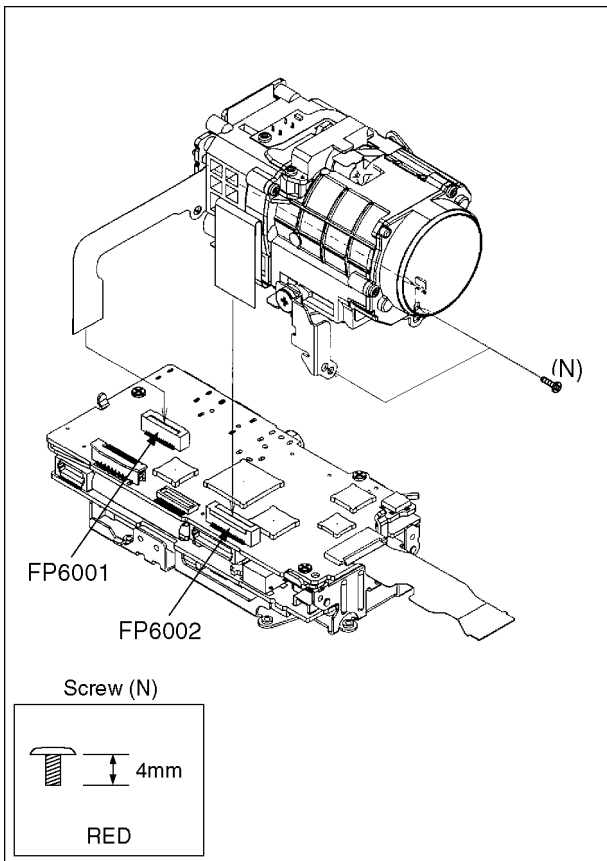

Fig. D16

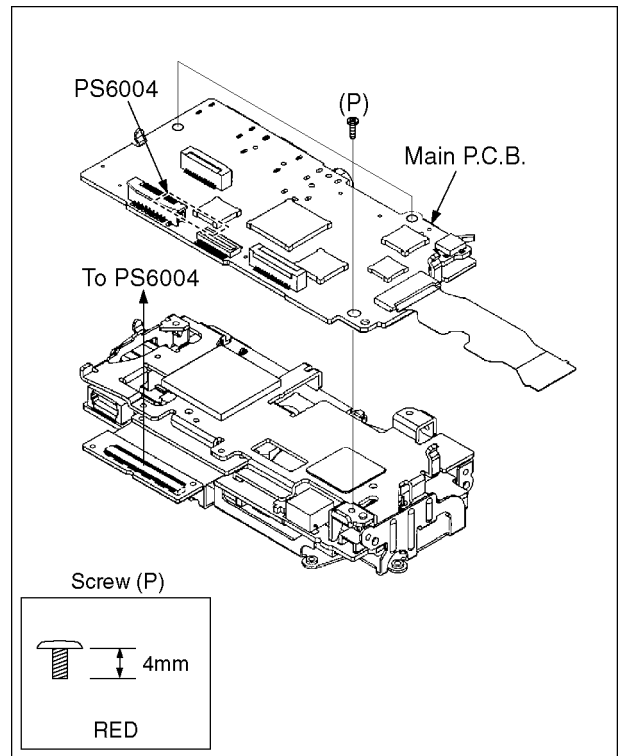

Fig. D18

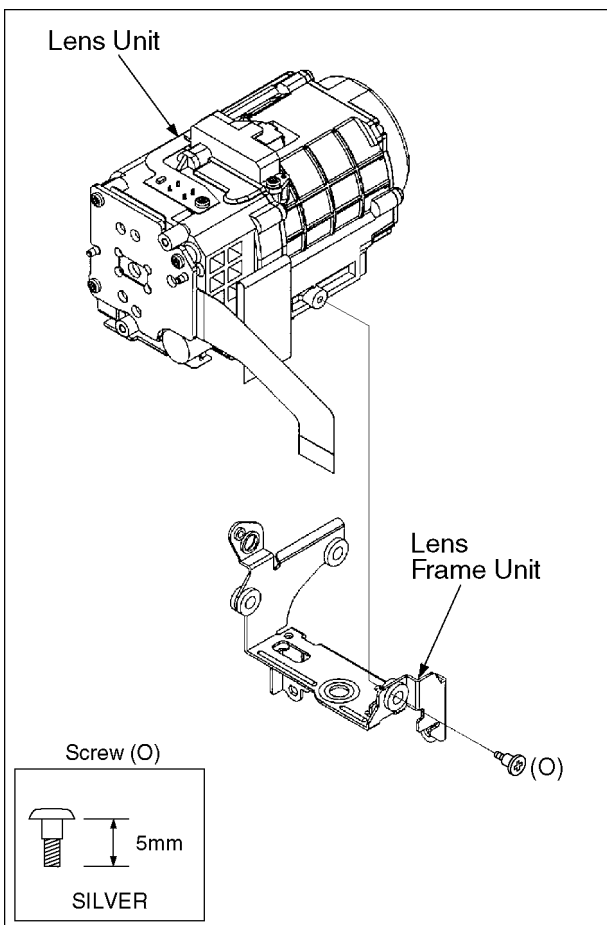

Fig. D17

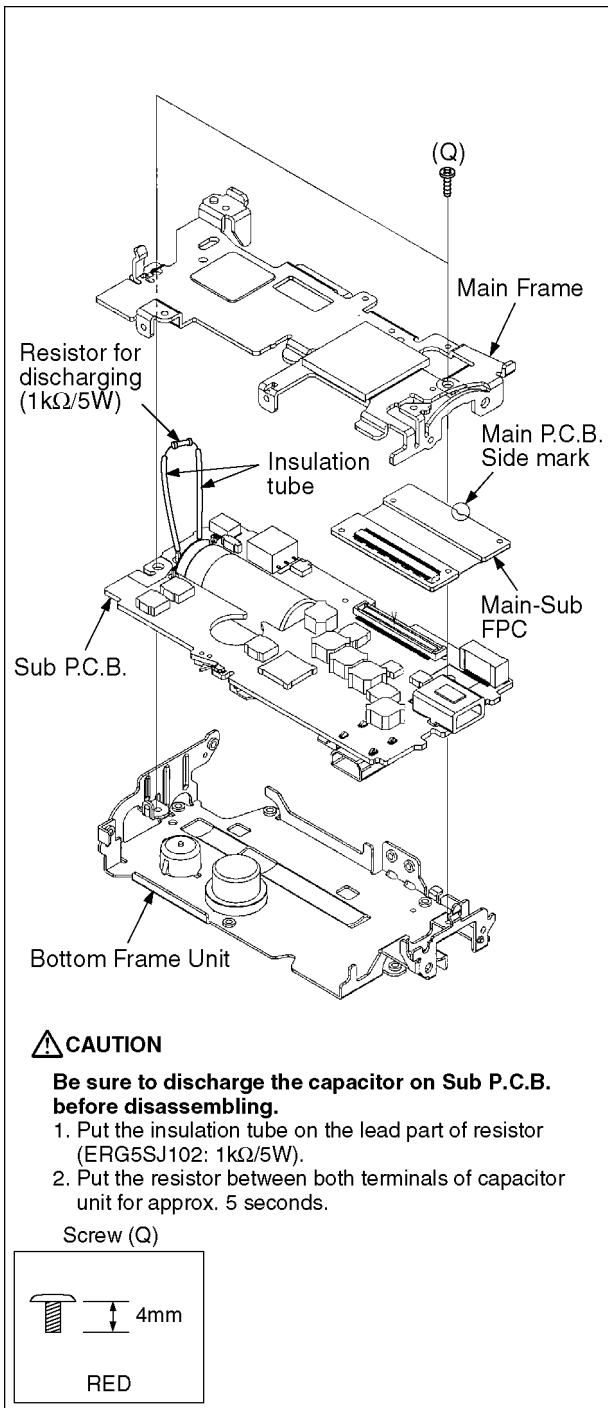

Fig. D19

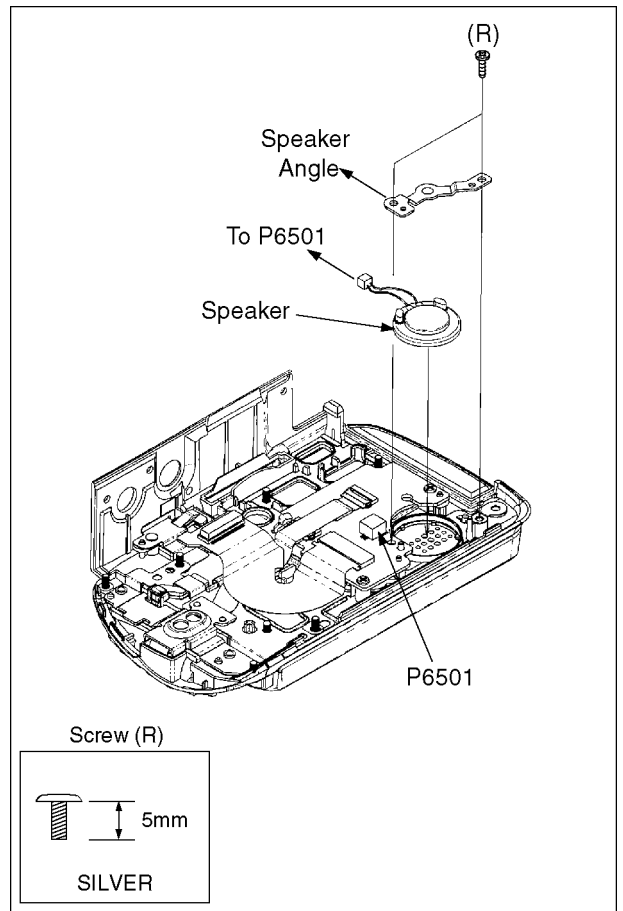

Fig. D20

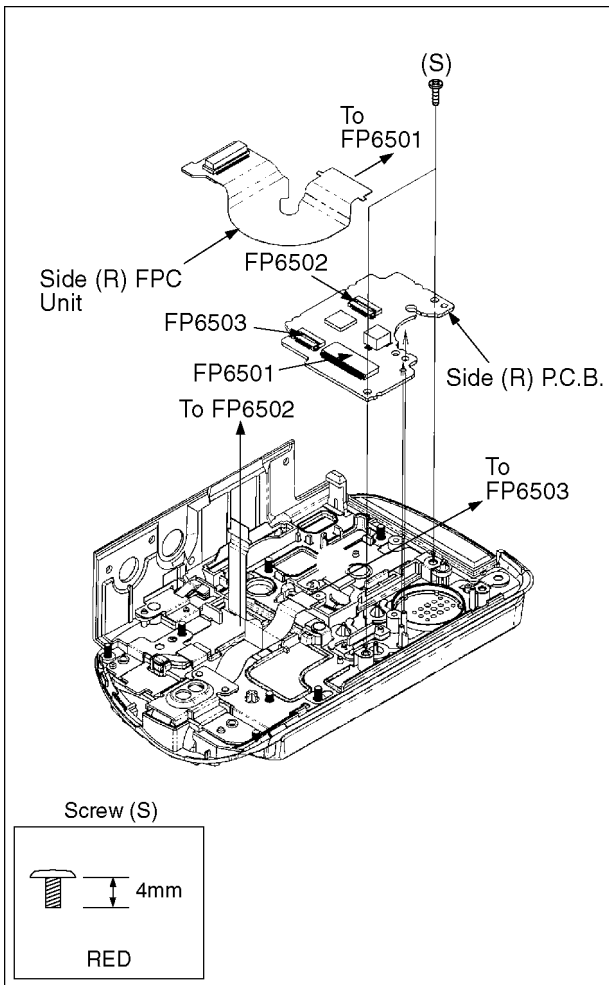

Fig. D21

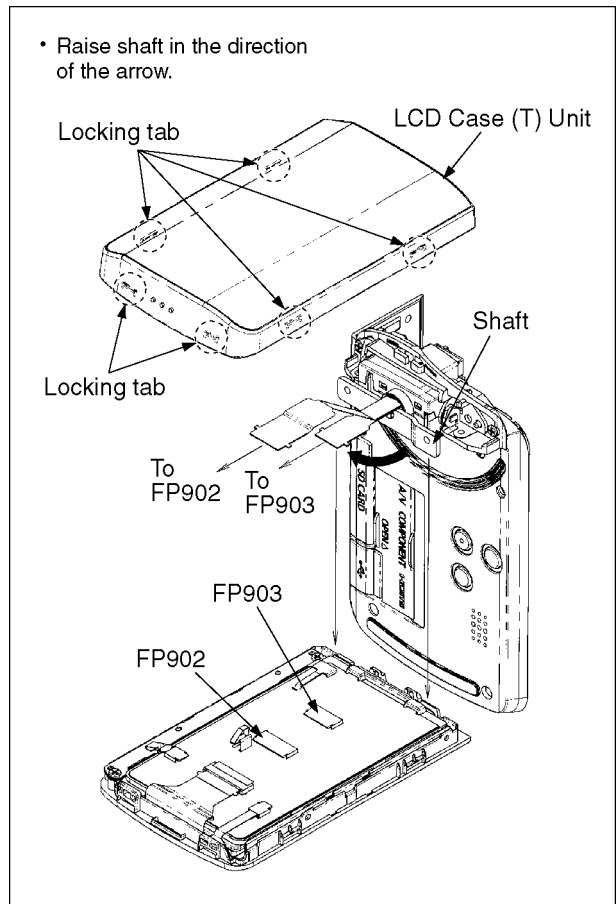

Fig. D23

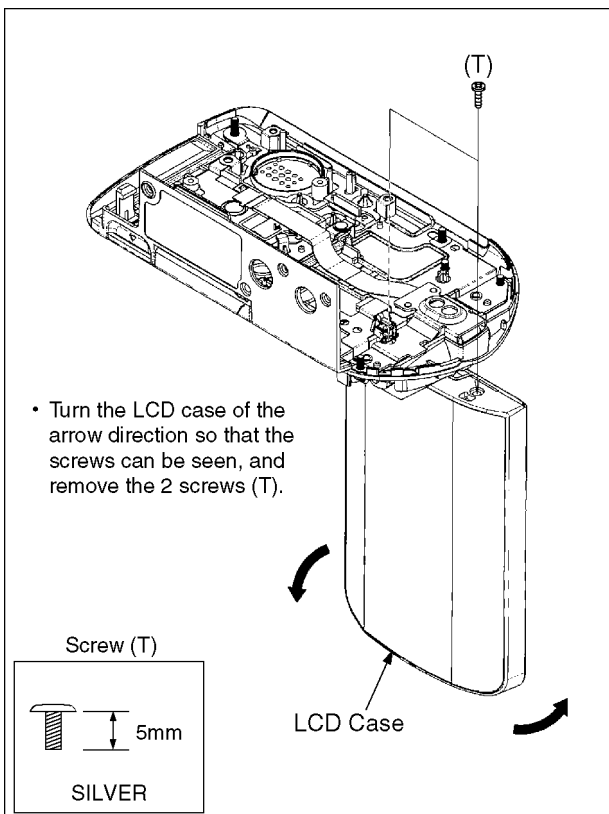

Fig. D22

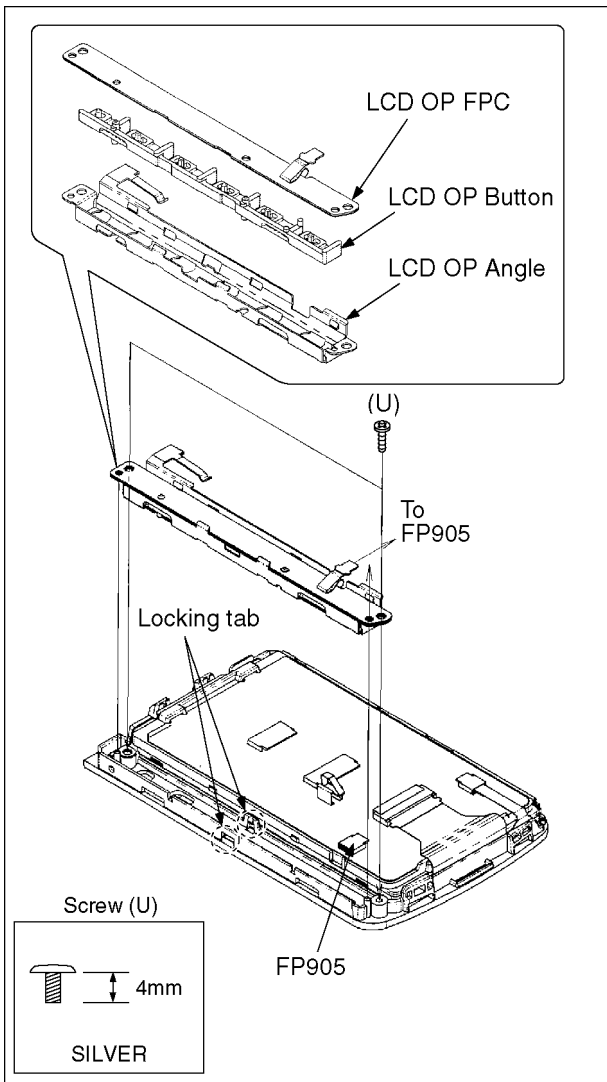

Fig. D24

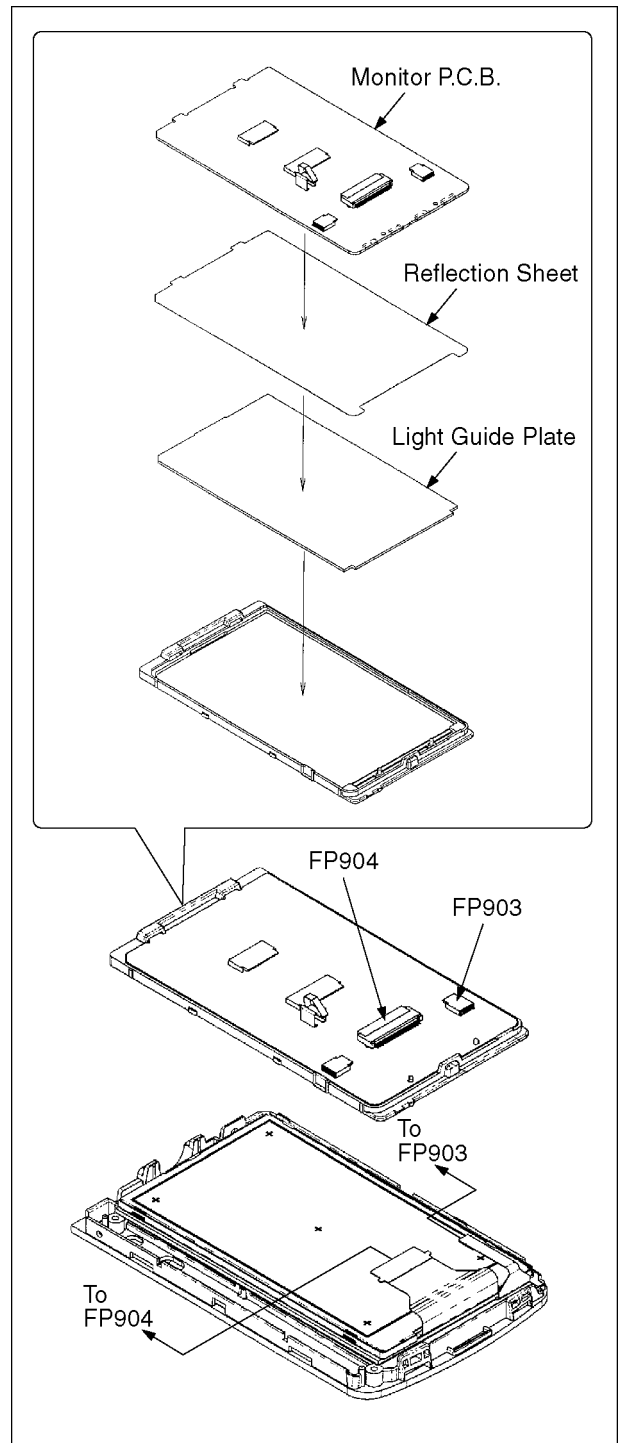

Fig. D25

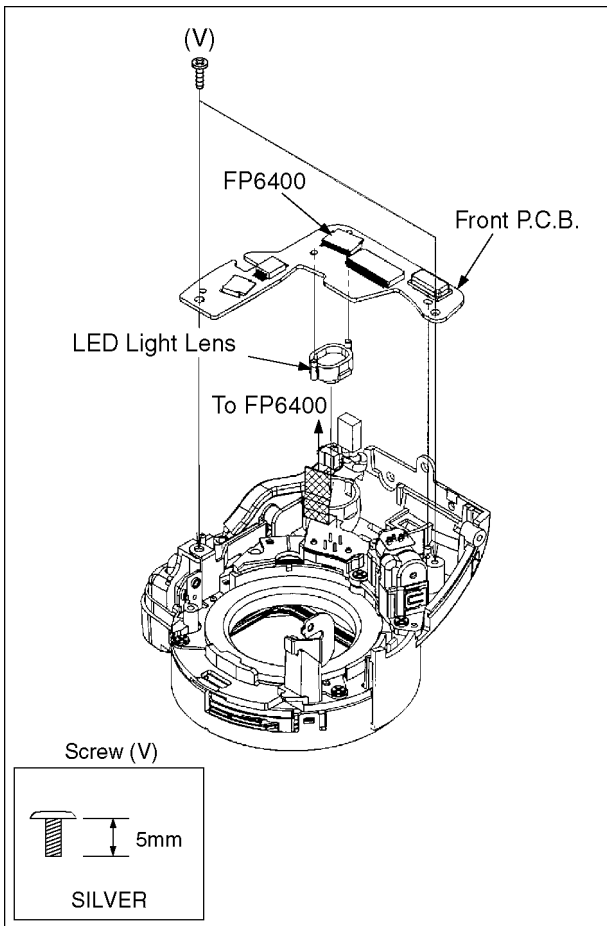

Fig. D26



## 8.4. Disassembly Procedures of Camera Lens Unit

The following flowchart describes order or steps for removing the Camera lens unit and certain printed circuit boards in order to make access to the item needing service.

To reassemble the unit follow the steps in reverse order.

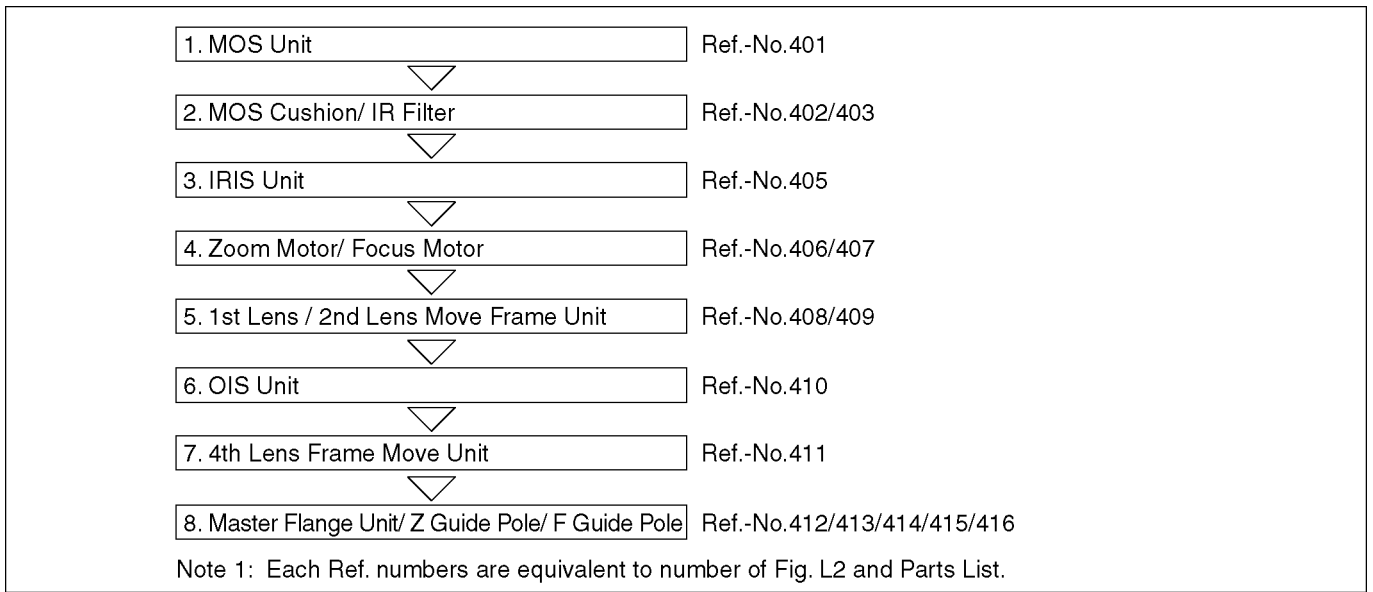

Fig. L1

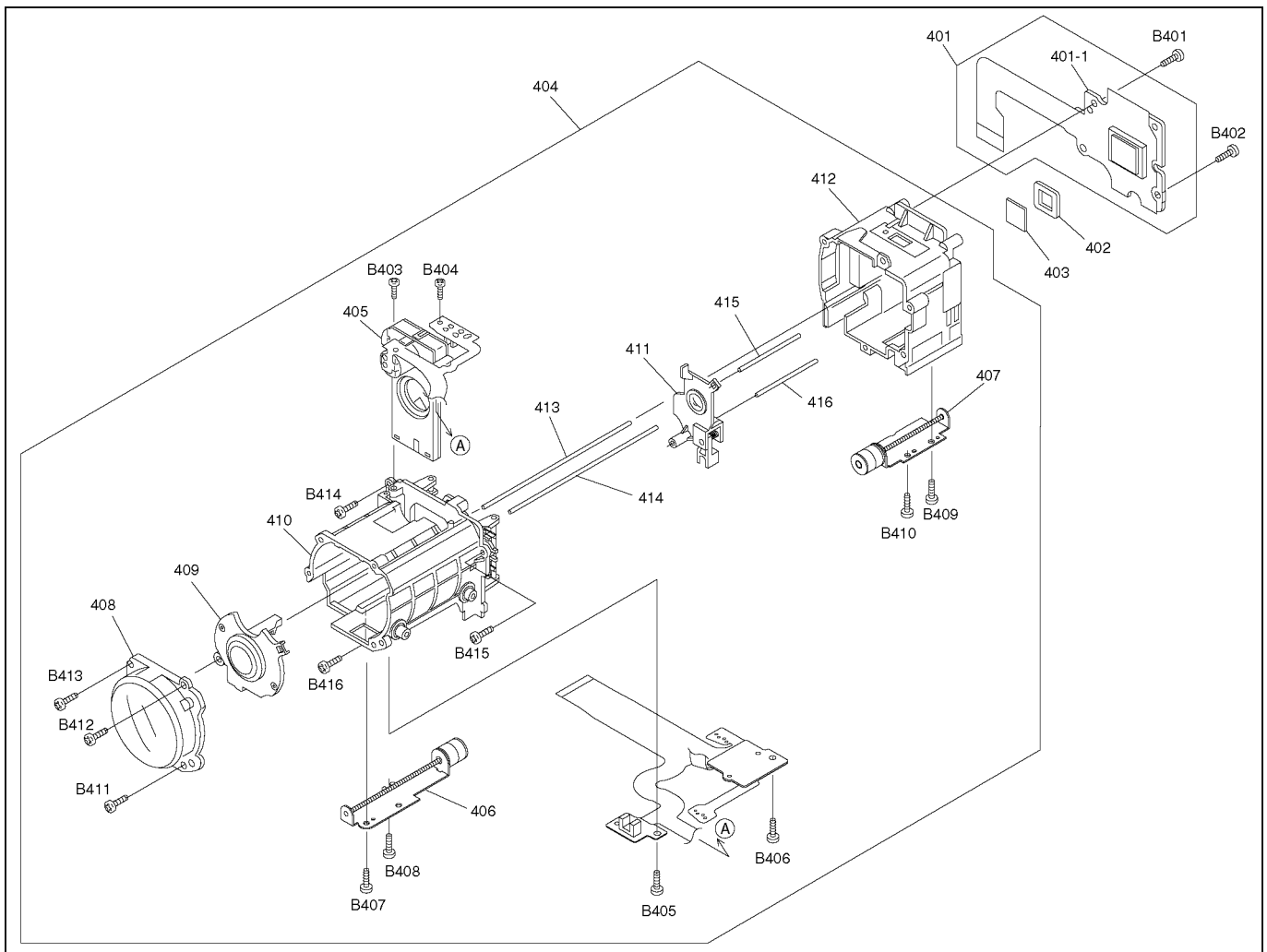

Fig. L2

## 9 Measurements and Adjustments

### 9.1. EEPROM Data for spare parts of the MAIN P.C.B.

After replacing the MAIN P.C.B., be sure to achieve adjustment.

The Adjustment instruction is available at "software download" on the "Support Information from NWBG/VDBG-PAVC" web-site in "TSN system", together with Maintenance software.

### 9.2. Service Positions

#### 9.2.1. List of the extension cables

Use the following extension cables when checking or adjusting individual circuit boards except module Parts (Main P.C.B. and Sub P.C.B.).

Ref.	Part No.	Pin	Part Name	Connection			Q'ty
1	RFKZ0448	33	Flat Cable	FP6003 (Main)	-	FP6403(Front P.C.B.)	1
2	RFKZ0379	40	Flat Cable	PS6003 (Main)	-	Side (R) FPC Unit	1
3	VFK1582A1620	16	Flat Cable	FP6006 (Main)	-	Top/Operation Unit	1
4	RFKZ0448	33	Flat Cable	FP6002 (Main)	-	Lens Unit	1
5	VFK1491	27	Flat Cable	FP6001 (Main)	-	MOS Unit	1
6	RFKZ0379	40	Flat Cable	PP6001 (Main)	-	HDD Unit	1
7	VFK1938	24	Flat Cable	PS6101 (Sub)	-	Battery Case Unit	1

## 9.2.2. Checking and repairing individual circuit boards except module parts (Main P.C.B. and Sub P.C.B.)

How to use extension cables.

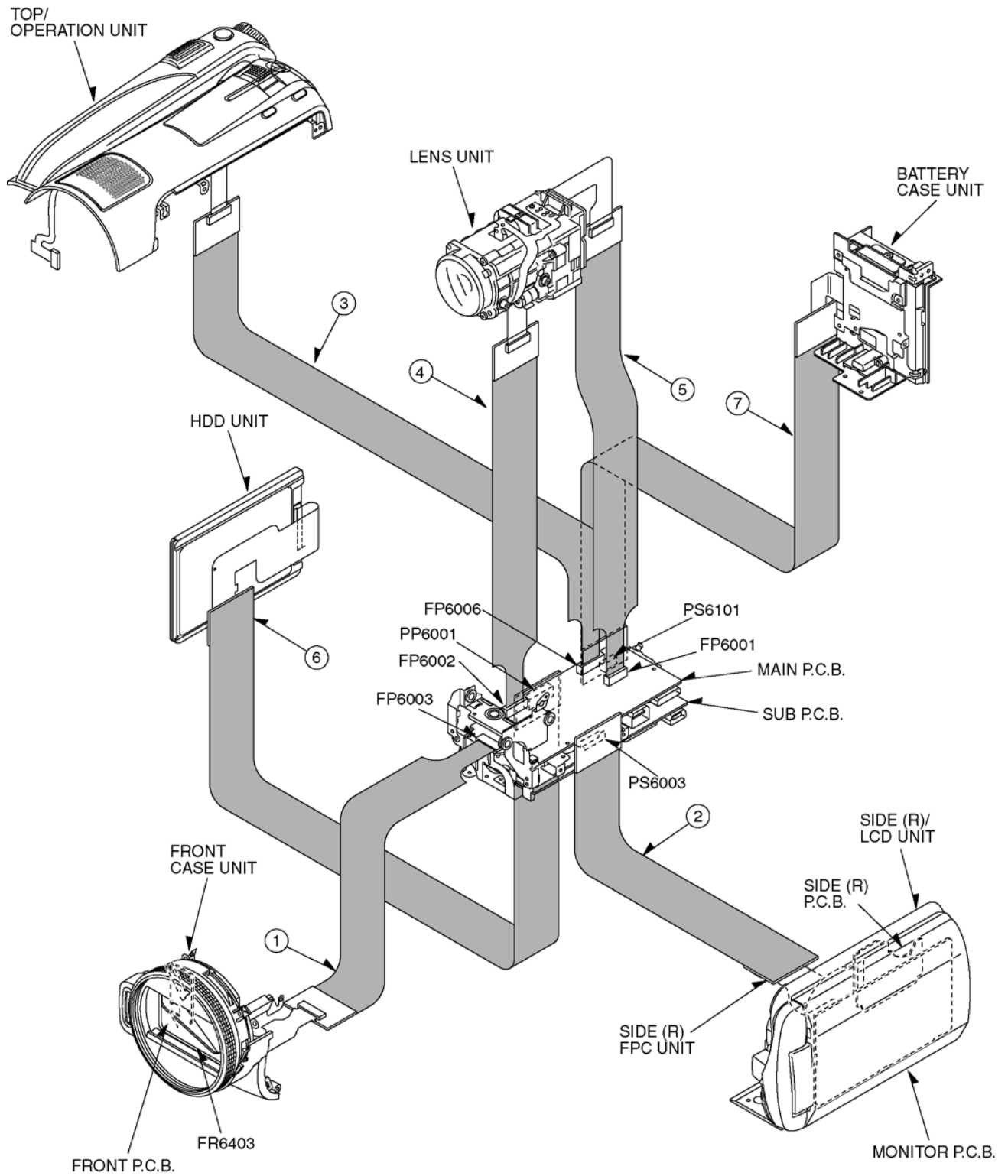

### 9.3. Location for Connectors of the Main P.C.B. and Sub P.C.B.

#### 9.3.1. Main P.C.B.

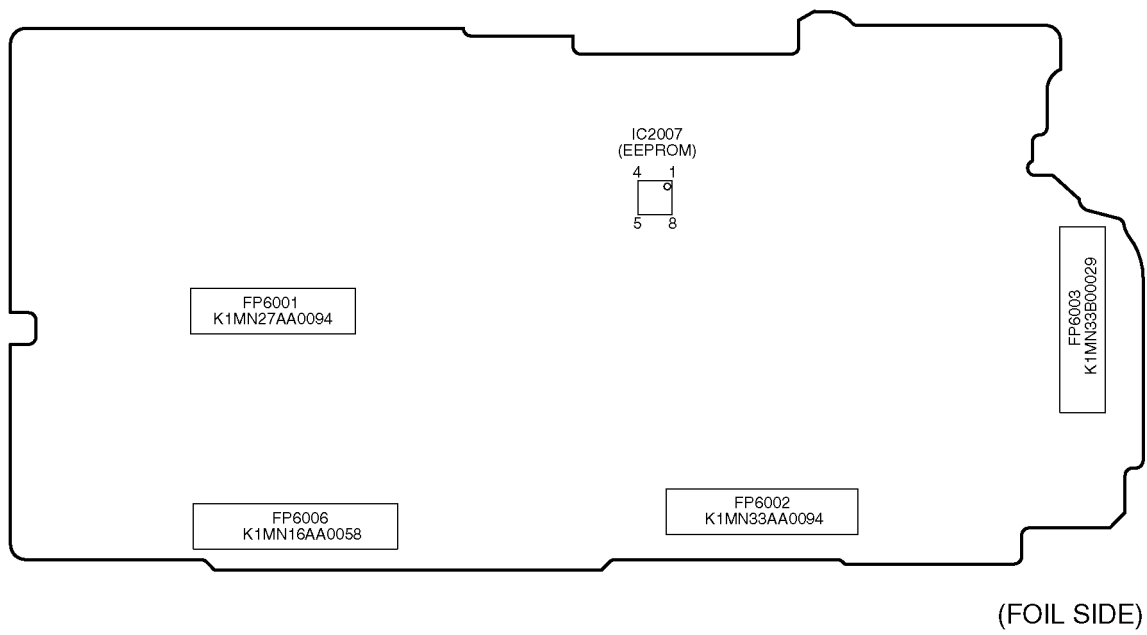
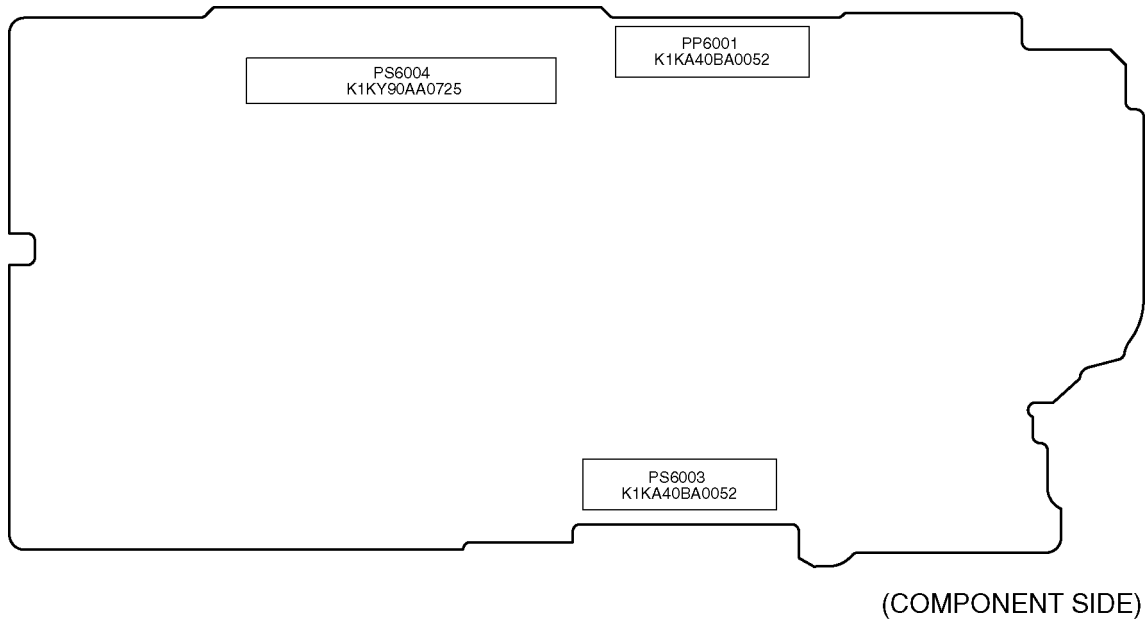

9.3.2. Sub P.C.B.

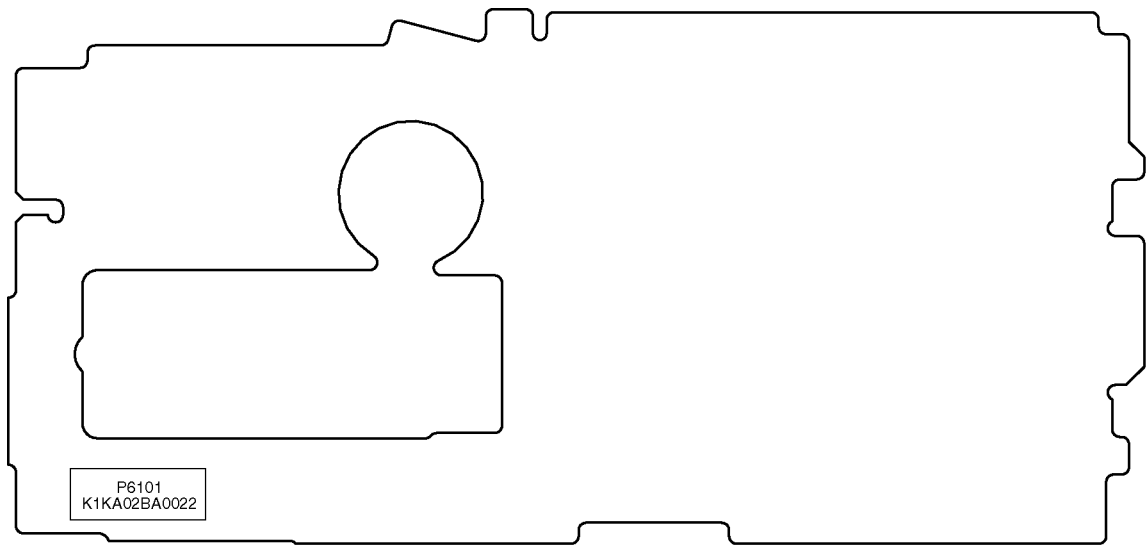

P6101  
K1KA02BA0022

(COMPONENT SIDE)

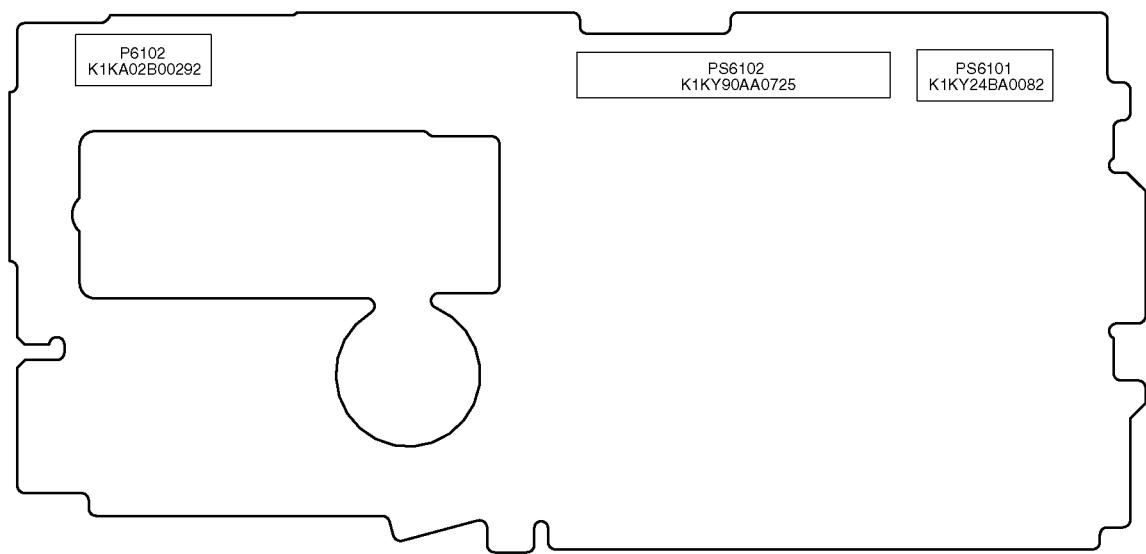

P6102  
K1KA02B00292

PS6102  
K1KY90AA0725

PS6101  
K1KY24BA0082

(FOIL SIDE)

## 9.4. Electrical Adjustment Procedures

### 9.4.1. Initial Guideline

The table below shows which adjustments are necessary according to the unit parts and individual parts to be replaced. Make sure to perform these adjustments shown below as necessary.

Adjustment Item		Replacement Parts							
		Main P.C.B.	IC2007 (EEPROM)	Lens Unit	MOS Unit	Iris Unit	4th Lens Frame Unit	IC3400	IC101/IC102/IC106
Camera	Hall amplifier/ PWM Bias (Auto)	<input type="radio"/>	<input type="radio"/>	<input type="radio"/>	<input type="radio"/>	<input type="radio"/>	<input type="radio"/>	<input type="radio"/>	<input type="radio"/>
	OIS hall amplifier adjustment	<input type="radio"/>	<input type="radio"/>	<input type="radio"/>	<input type="radio"/>	<input type="radio"/>	<input type="radio"/>	<input type="radio"/>	<input type="radio"/>
	Zoom Tracking adjustment (Auto)	<input type="radio"/>	<input type="radio"/>	<input type="radio"/>	<input type="radio"/>	<input type="radio"/>	<input type="radio"/>	<input type="radio"/>	<input type="radio"/>
	Address Wound Revision (Auto)	<input type="radio"/>	<input type="radio"/>	<input type="radio"/>	<input type="radio"/>	<input type="radio"/>	<input type="radio"/>	<input type="radio"/>	<input type="radio"/>
	White Balance adjustment	<input type="radio"/>	<input type="radio"/>	<input type="radio"/>	<input type="radio"/>	<input type="radio"/>	<input type="radio"/>	<input type="radio"/>	<input type="radio"/>
	Gain adjustment between channels	<input type="radio"/>	<input type="radio"/>	<input type="radio"/>	<input type="radio"/>	<input type="radio"/>	<input type="radio"/>	<input type="radio"/>	<input type="radio"/>
Video	Brightness Level adjustment	<input type="radio"/>	<input type="radio"/>	<input type="radio"/>	<input type="radio"/>	<input type="radio"/>	<input type="radio"/>	<input type="radio"/>	<input type="radio"/>
	DDR Revision	<input type="radio"/>	<input type="radio"/>	<input type="radio"/>	<input type="radio"/>	<input type="radio"/>	<input type="radio"/>	<input type="radio"/>	<input type="radio"/>

: Adjustment Item

### 9.4.2. Computer assisted adjustment system <TATSUJIN> adjustment

This unit employs the computer assisted system named; **TATSUJIN PC-Adjustment** for Electrical adjustment. It is required to install a USB driver for service which can be download only from TSN-WEB.

### 9.4.3. Set-up manual for High Definition Video Camera

Pay attention, because the adjustment method is different from this machine.

1. Save the software

Install the effective model's TATSUJIN Software to PC: Personal Computer.

2. Set-Up

- a. It need the connection between the PC and this unit with USB cable.
- b. Connect the PC and High Definition Video Camera as shown in Fig. E1 and E2.
- c. The adjustment instruction is available at [Software download](#) on the [Support Information from NWBG-PAVC](#) web-site in [TSN System](#), together with maintenance software.

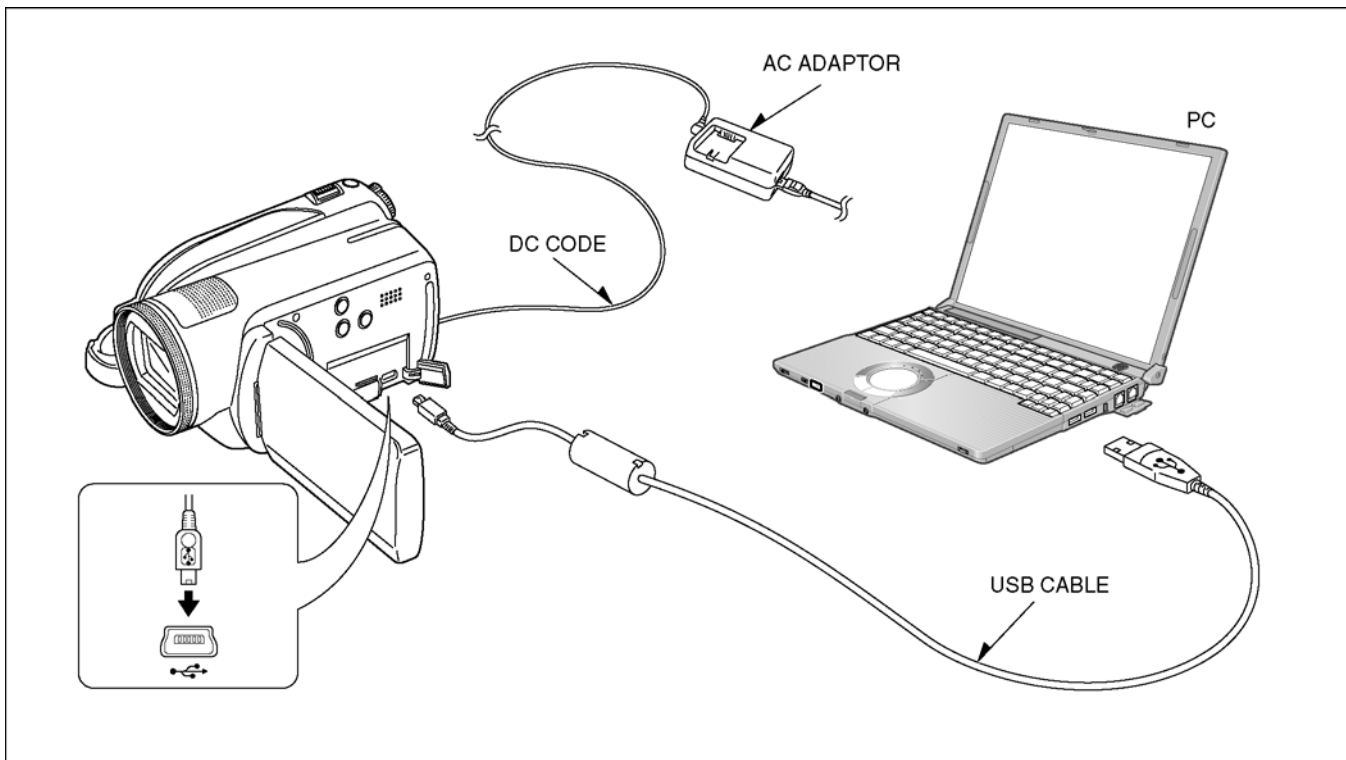

Fig. E1

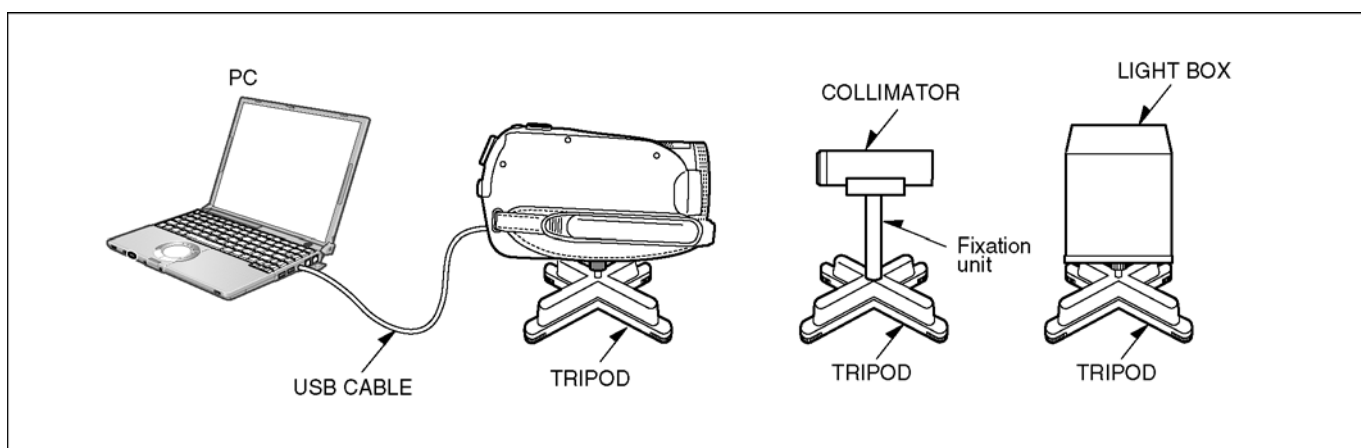

Fig. E2 Rough image of set-up connection

Ref	Parts Name	Parts No.	Q'ty	Remarks
1	Personal Computer	---	1	With Tatsujin Software.
2	AC Adaptor	---	1	The AC Adaptor for High Definition Video Camera
3	DC Cable	---	1	The AC Adaptor for High Definition Video Camera
4	USB Cable	---	1	
5	Step Up Ring	VFK1164TAR43	1	
6	TATSUJIN PC-Adjustment Program	---	1	

### 9.4.4. Set up PC-EVR adjustment program

1. Turn on the PC and install the TATSUJIN Adjustment Program into the PC.
2. TATSUJIN PC-Adjustment Program start in the following procedure.  
PC Menu : [Start] → [Program] → [win Tatsujin] → [DV Movie] → [HDC-HS20 Series]

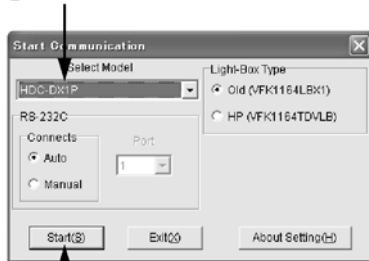

Fig. E3-1

The main menu display will be displayed.

3. Select the desired model.
4. Turn on the camcorder. Then, click **Start**.

① Select the appropriate model.



② Click to start.

Fig. E3-2

5. The communication is complete, and the dialog will appear.

Then, click **Cam or Arm** to save the EEPROM data,

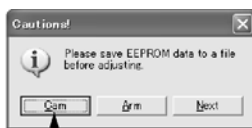

③ Click.

Fig. E3-3

6. Saving for EEPROM data is complete, menu will appear. To perform each adjustment, display the adjustment menu by selecting the desired menu from **Camera Adjust** or **Video Adjust** and select each adjustment item.

④ Select the desired menu.

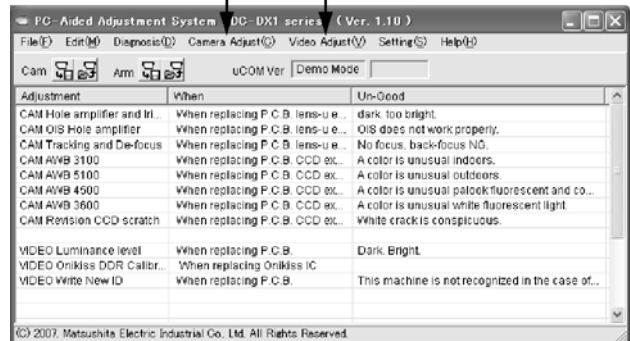

Fig. E3-4

**Note:**

The adjustment data is stored to the EEPROM IC after each adjustment.

7. After adjustment, to end the software, select **Exit** in File menu or close the window.

⑤ Select "Exit" or close the window.

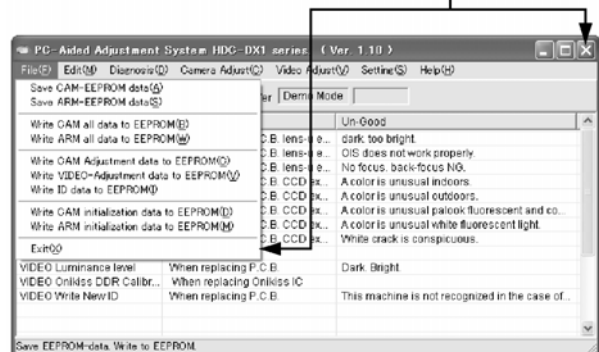

Fig. E3-5



# 10 Maintenance

## 10.1. Cleaning Lens and LCD Panel

Do not touch the surface of the lens and LCD Panel with your hand.

When cleaning the lens, use air-Blower to blow off the dust.

When cleaning the LCD Panel, dampen the lens cleaning paper with lens cleaner, and the gently wipe the their surface.

**Note:**

A lens cleaning paper and lens cleaner are available at local camera shops and market place.

# Service Manual

---

## Diagrams and Replacement Parts List

### High Definition Video Camera

Model No.

HDC-HS20P	HDC-HS20EP
HDC-HS20PC	HDC-HS20GC
HDC-HS20PU	HDC-HS20GJ
HDC-HS20EB	HDC-HS20GK
HDC-HS20EC	HDC-HS20GN
HDC-HS20EE	HDC-HS20GT
HDC-HS20EF	HDC-HS20SG
HDC-HS20EG	HDC-HS25EB

Vol. 1  
 Colour  
 (K).....Black Type

## S1. About Indication of The Schematic Diagram

### S1.1. Important Safety Notice

COMPONENTS IDENTIFIED WITH THE MARK  $\triangle$  HAVE THE SPECIAL CHARACTERISTICS FOR SAFETY. WHEN REPLACING ANY OF THESE COMPONENTS USE ONLY THE SAME TYPE.

1. Although reference number of the parts is indicated on the P.C.B. drawing and/or schematic diagrams, it is NOT mounted on the P.C.B. when it is displayed with "\$" mark.
2. It is only the "Test Round" and no terminal (Pin) is available on the P.C.B. when the TP (Test Point) indicated as "●" mark.
3. The voltage being indicated on the schematic diagram is measured in "Standard-Playback" mode when there is no specify mode is mentioned.
4. Although the voltage and waveform available on here is measured with standard frame, it may be differ from actual measurement due to modification of circuit and so on.
5. The voltage being indicated here may be include observational-error (deviation) due to internal-resistance and/or reactance of equipment. Therefore, handle the value indicated on here as reference.
6. Use the parts number indicated on the Replacement Parts List .
7. Indication on Schematic diagrams:

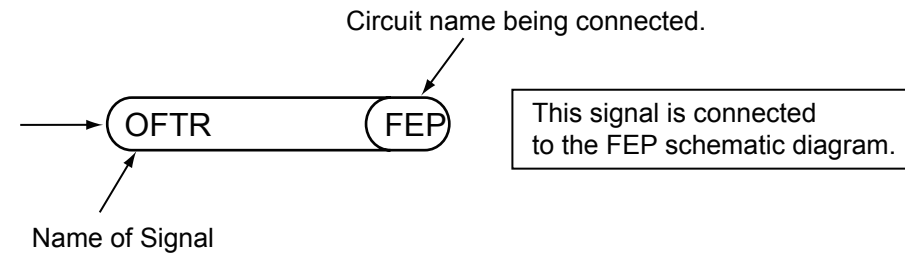

## Table of contents

S1. About Indication of The Schematic Diagram.....	S-1	S4.8. Main Sub FPC Schematic Diagram .....	S-11	S5.10. HDD FPC P.C.B. ....	S-26
S1.1. Important Safety Notice.....	S-1	S4.9. Side R FPC Schematic Diagram.....	S-12	S5.10.1. HDD FPC P.C.B. (Component Side).....	S-26
S2. Voltage Chart .....	S-2	S4.10. Front FPC Schematic Diagram .....	S-13	S5.10.2. HDD FPC P.C.B. (Foil Side).....	S-27
S2.1. Side R P.C.B. ....	S-2	S4.11. LCD_OP FPC Schematic Diagram .....	S-14	S6. Check Point of The IC.....	S-29
S2.2. Front P.C.B. ....	S-2	S4.12. MOS FPC Schematic Diagram .....	S-15	S6.1. Check Point of The IC601 .....	S-29
S2.3. Monitor P.C.B. ....	S-2	S4.13. HDD FPC Schematic Diagram.....	S-16	S7. Replacement Parts List.....	S-30
S3. Block Diagram.....	S-3	S5. Print Circuit Board.....	S-17	S8. Exploded View .....	S-36
S3.1. Overall Block Diagram .....	S-3	S5.1. Side R P.C.B. ....	S-17	S8.1. Frame and Casing Section (1) .....	S-36
S4. Schematic Diagram.....	S-4	S5.2. Front P.C.B. ....	S-18	S8.2. Frame and Casing Section (2) .....	S-37
S4.1. Interconnection Diagram .....	S-4	S5.3. Monitor P.C.B. ....	S-19	S8.3. LCD Section.....	S-38
S4.2. Side R Schematic Diagram .....	S-5	S5.3.1. Monitor P.C.B. (Component Side).....	S-19	S8.4. Camera Lens Section.....	S-39
S4.3. LCD Schematic Diagram.....	S-6	S5.3.2. Monitor P.C.B. (Foil Side).....	S-20	S8.5. Packing Parts and Accessories Section.....	S-40
S4.4. Front Schematic Diagram .....	S-7	S5.4. Power FPC P.C.B. ....	S-21		
S4.5. Monitor Schematic Diagram.....	S-8	S5.5. Main Sub FPC P.C.B. ....	S-22		
S4.6. TPANEL Schematic Diagram .....	S-9	S5.6. Side R FPC P.C.B. ....	S-23		
S4.7. Power FPC Schematic Diagram .....	S-10	S5.7. Front FPC P.C.B. ....	S-23		
		S5.8. LCD_OP FPC P.C.B. ....	S-24		
		S5.9. MOS FPC P.C.B. ....	S-25		

## S2. Voltage Chart

Note) Indicated voltage values are the standard values for the unit measured by the DC electronic circuit tester (high-impedance) with the chassis taken as standard.  
Therefore, there may exist some errors in the voltage values, depending on the internal impedance of the DC circuit tester.

### S2.1. Side R P.C.B.

REF No.	PIN No.	REC	PB	EE
IC601	1	0	0	0
IC601	2	0	0	0
IC601	3	0	0	0
IC601	4	-	-	-
IC601	5	-	-	-
IC601	6	-	-	-
IC601	7	-	-	-
IC601	8	-	-	-
IC601	9	-	-	-
IC601	10	-	-	-
IC601	11	-	-	-
IC601	12	-	-	-
IC601	13	1.6	1.6	1.6
IC601	14	0	0	0
IC601	15	1.4	1.4	1.4
IC601	16	0	0	0
IC601	17	0	0	0
IC601	18	1.8	1.8	1.8
IC601	19	0	0	0
IC601	20	1.8	1.8	1.8
IC601	21	-	-	-
IC601	22	-	-	-
IC601	23	-	-	-
IC601	24	-	-	-
IC601	25	-	-	-
IC601	26	-	-	-
IC601	27	0	0	0
IC601	28	-	-	-
IC601	29	-	-	-
IC601	30	0	0	0
IC601	31	1.8	1.8	1.8
IC601	32	1.2	1.2	1.2
IC601	33	0	0	0
IC601	34	1.8	1.8	1.8
IC601	35	0	0	0
IC601	36	0	0	0
IC601	37	0	0	0
IC601	38	1	1	1
IC601	39	-	-	-
IC601	40	0	0	0
IC601	41	1	1	1
IC601	42	1.8	1.8	1.8
IC601	43	1.8	1.8	1.8
IC601	44	0	0	0
IC601	45	0	0	0
IC601	46	0	0	0
IC601	47	0	0	0
IC601	48	0	0	0
IC601	49	0	0	0

### S2.2. Front P.C.B.

REF No.	PIN No.	REC	PB	EE
IC4801	1	2.4	2.4	2.4
IC4801	2	2.4	2.4	2.4
IC4801	3	2.4	2.4	2.4
IC4801	4	0	0	0
IC4801	5	2.4	2.4	2.4
IC4801	6	2.4	2.4	2.4
IC4801	7	2.4	2.4	2.4
IC4801	8	4.9	4.9	4.9
IC4803	1	2.4	2.4	2.4
IC4803	2	2.4	2.4	2.4
IC4803	3	2.4	2.4	2.4
IC4803	4	0	0	0
IC4803	5	2.4	2.4	2.4
IC4803	6	2.4	2.4	2.4
IC4803	7	2.4	2.4	2.4
IC4803	8	4.9	4.9	4.9
IC6401	1	1.4	1.4	1.4
IC6401	2	0	0	0
IC6401	3	3	3	3
IC6401	4	1.4	1.4	1.4
IC6402	1	1.4	1.4	1.4
IC6402	2	0	0	0
IC6402	3	3	3	3
IC6402	4	1.4	1.4	1.4
Q4801	E	4.8	4.8	4.8
Q4801	C	4.9	4.9	4.9
Q4801	B	4.2	4.2	4.2
Q6421	E	0	0	0
Q6421	C	0	0	0
Q6421	B	0	0	0
Q6422	E	0	0	0
Q6422	C	0	0	0
Q6422	B	0	0	0
Q6423	E	0	0	0
Q6423	C	0	0	0
Q6423	B	0	0	0
QR6402	E	3	3	3
QR6402	C	3	3	3
QR6402	B	0	0	0
QR6421	E	4.9	4.9	4.9
QR6421	C	0	0	0
QR6421	B	4.8	4.8	4.8
QR6422	E	0	0	0
QR6422	C	4.8	4.8	4.8
QR6422	B	0	0	0

### S2.3. Monitor P.C.B.

REF No.	PIN No.	REC	PB	EE
IC501	1	-	-	-
IC501	2	1	1	1
IC501	3	1.7	1.7	1.7
IC501	4	0.9	0.9	0.9
IC501	5	3	3	3
IC501	6	1	1	1
IC501	7	1	1	1
IC501	8	0	0	0
IC501	9	0	0	0
IC501	10	0	0	0
IC501	11	-	-	-
IC501	12	-	-	-
IC501	13	1.5	1.5	1.5
IC501	14	3	3	3
IC501	15	-	-	-
IC501	16	1.2	1.2	1.2
Q901	E	0.3	0.3	0.3
Q901	C	1.4	1.4	1.4
Q901	B	1.1	1.1	1.1
Q902	E	0.3	0.3	0.3
Q902	C	1.4	1.4	1.4
Q902	B	1.1	1.1	1.1
Q903	E	0.3	0.3	0.3
Q903	C	1.4	1.4	1.4
Q903	B	1.1	1.1	1.1
Q904	E	0.3	0.3	0.3
Q904	C	1.4	1.4	1.4
Q904	B	1.1	1.1	1.1
Q910	E	1.4	1.4	1.4
Q910	C	0	0	0
Q910	B	0.6	0.6	0.6

# S3. Block Diagram

## S3.1. Overall Block Diagram

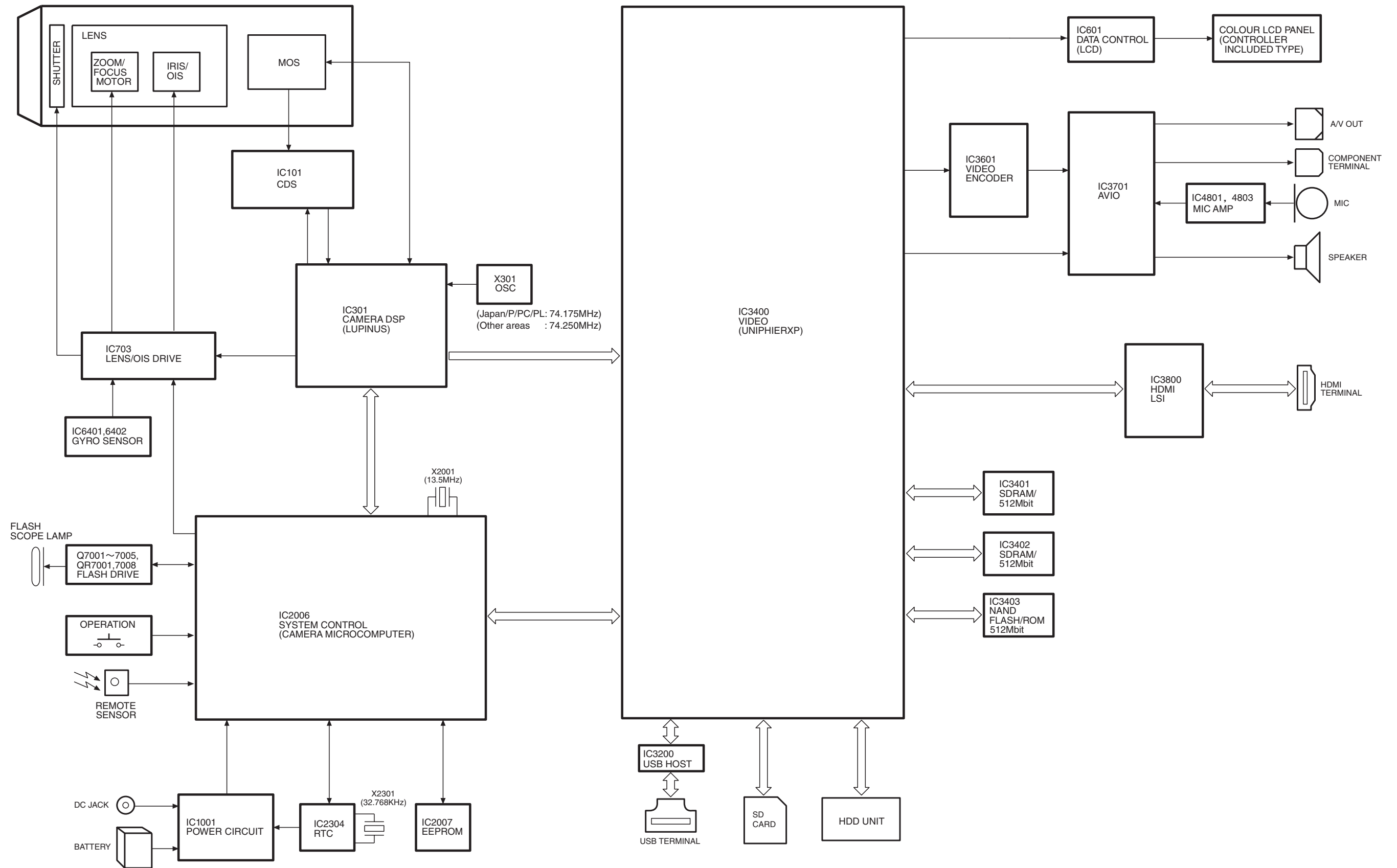





### S4.3. LCD Schematic Diagram

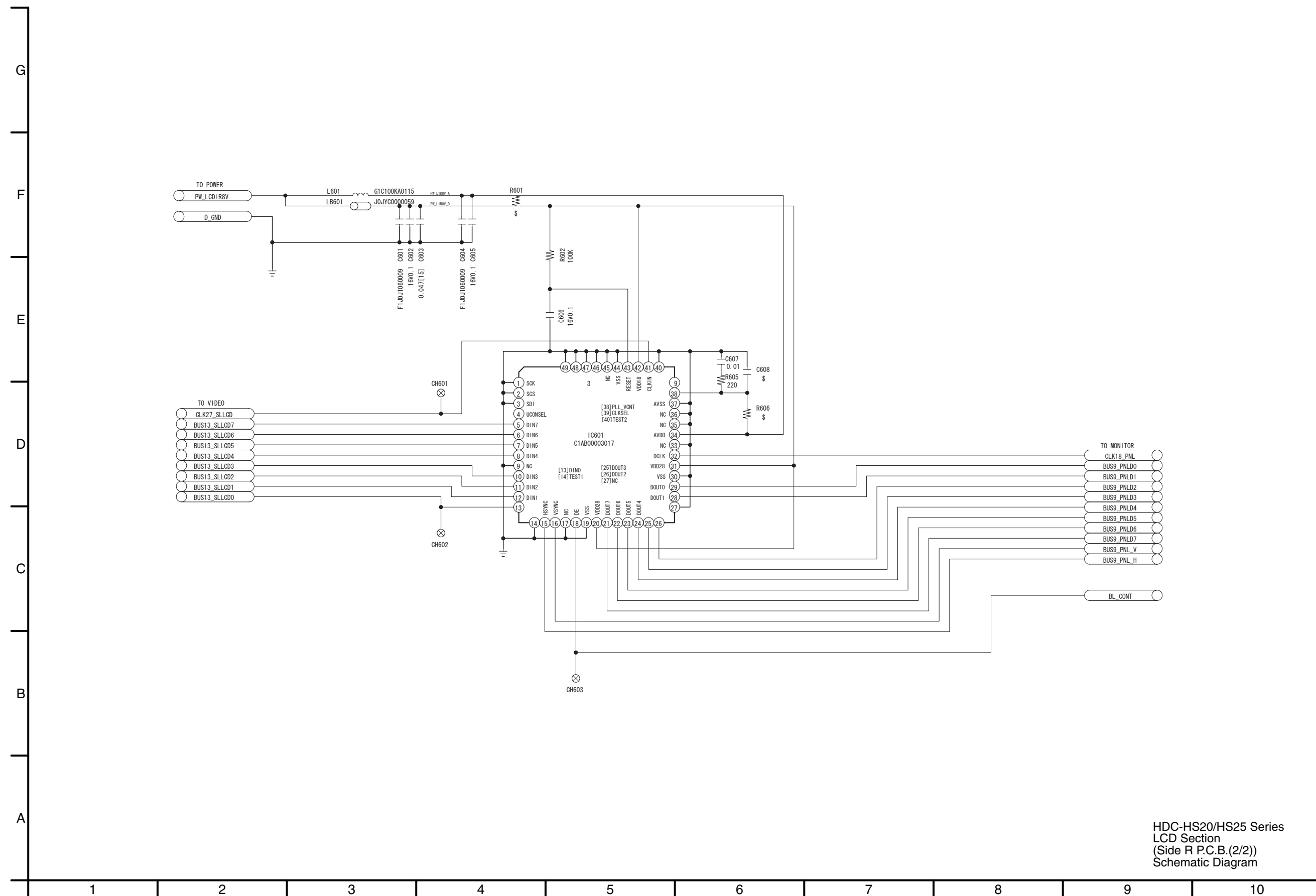

HDC-HS20/HS25 Series  
LCD Section  
(Side R P.C.B.(2/2))  
Schematic Diagram

# S4.4. Front Schematic Diagram

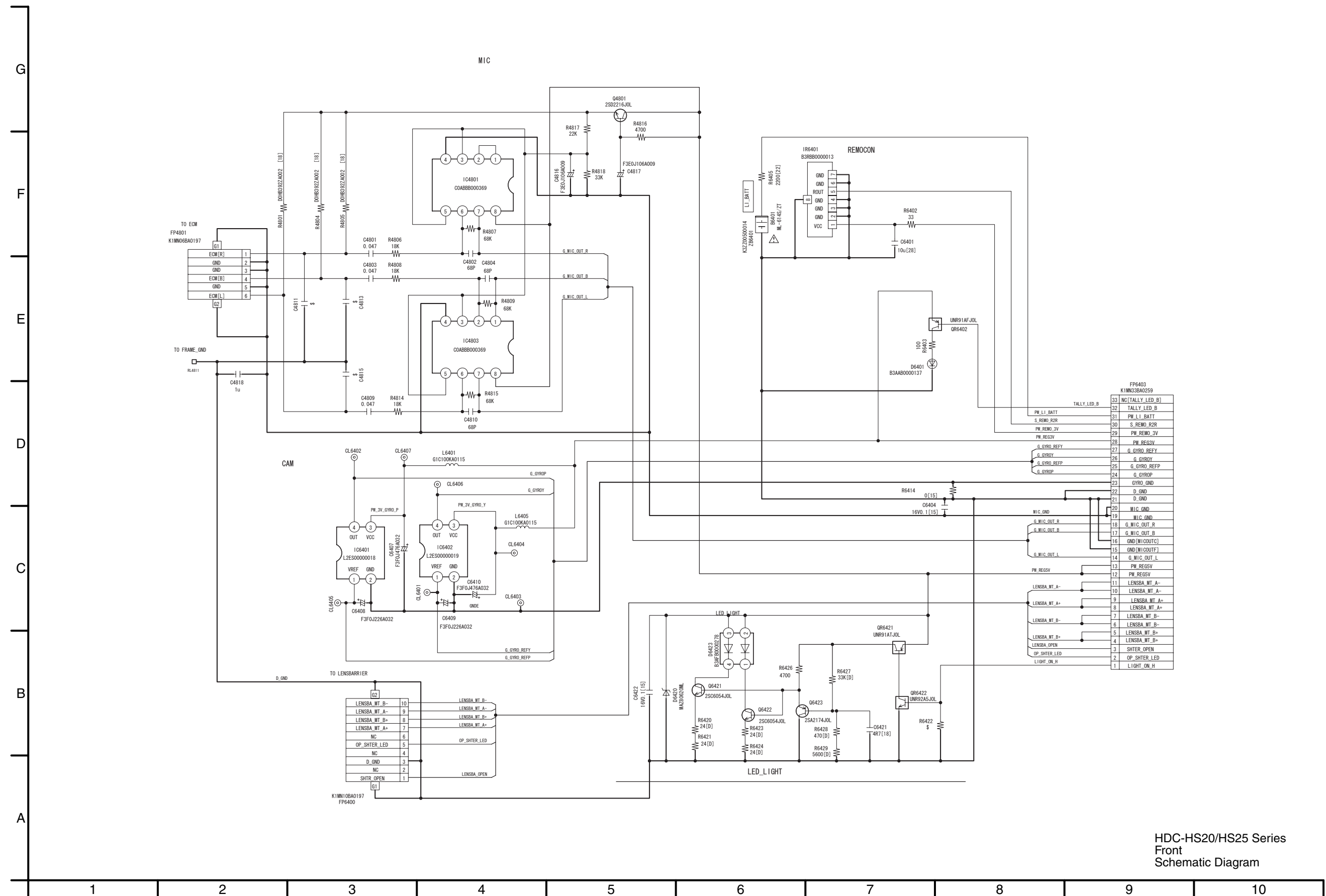

HDC-HS20/HS25 Series  
Front  
Schematic Diagram



# S4.5. Monitor Schematic Diagram

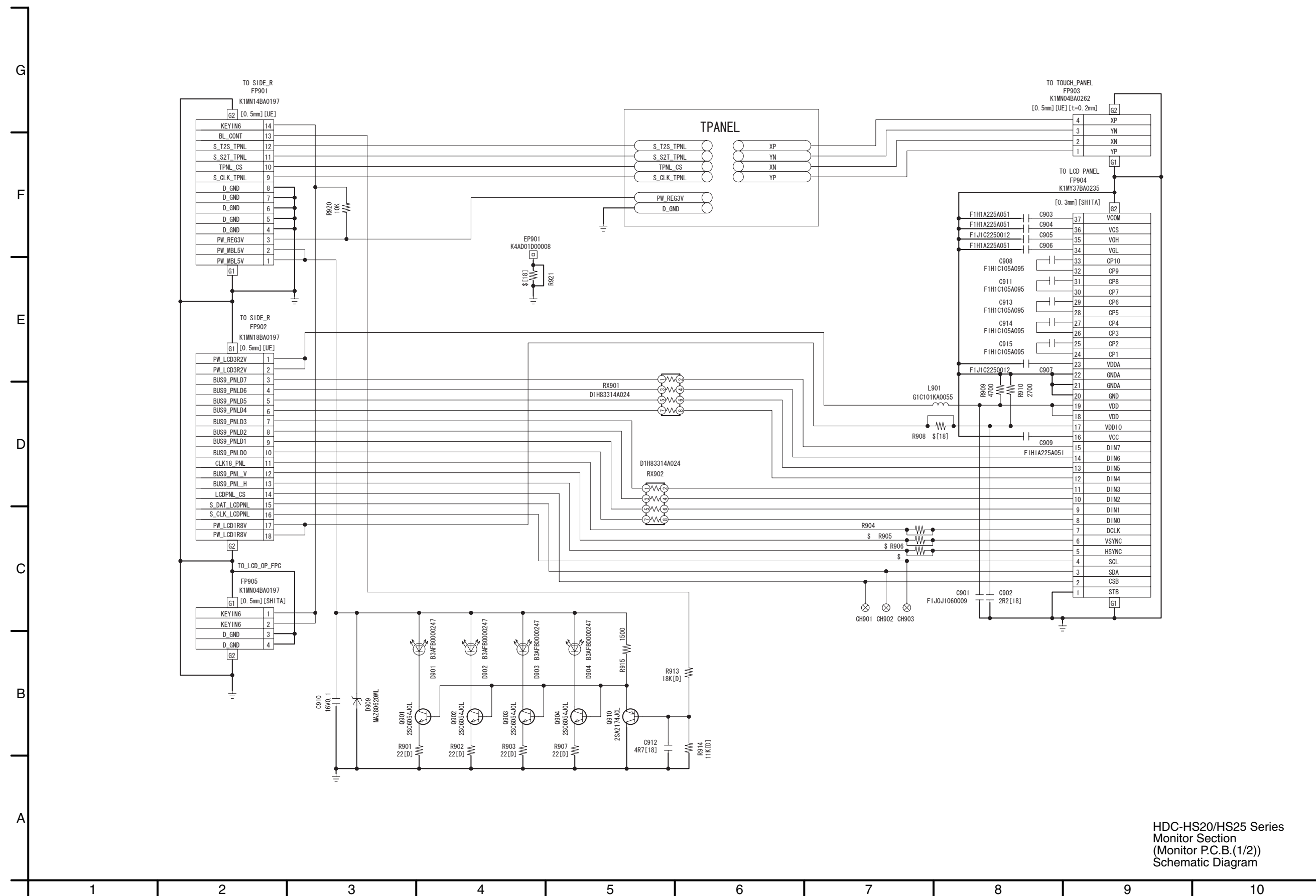

HDC-HS20/HS25 Series  
Monitor Section  
(Monitor P.C.B.(1/2))  
Schematic Diagram

# S4.6. TPANEL Schematic Diagram

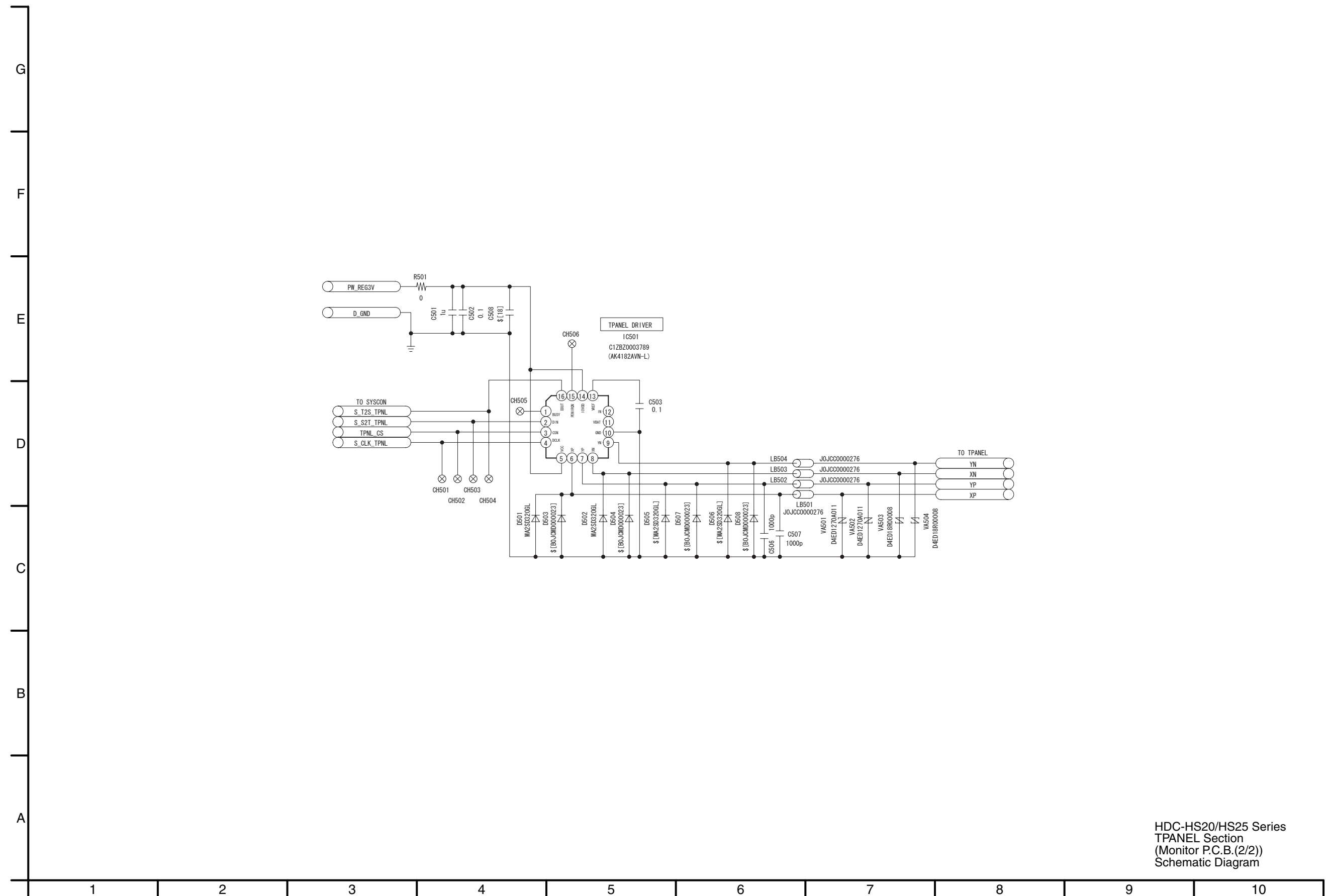

HDC-HS20/HS25 Series  
 TPANEL Section  
 (Monitor P.C.B.(2/2))  
 Schematic Diagram

# S4.7. Power FPC Schematic Diagram

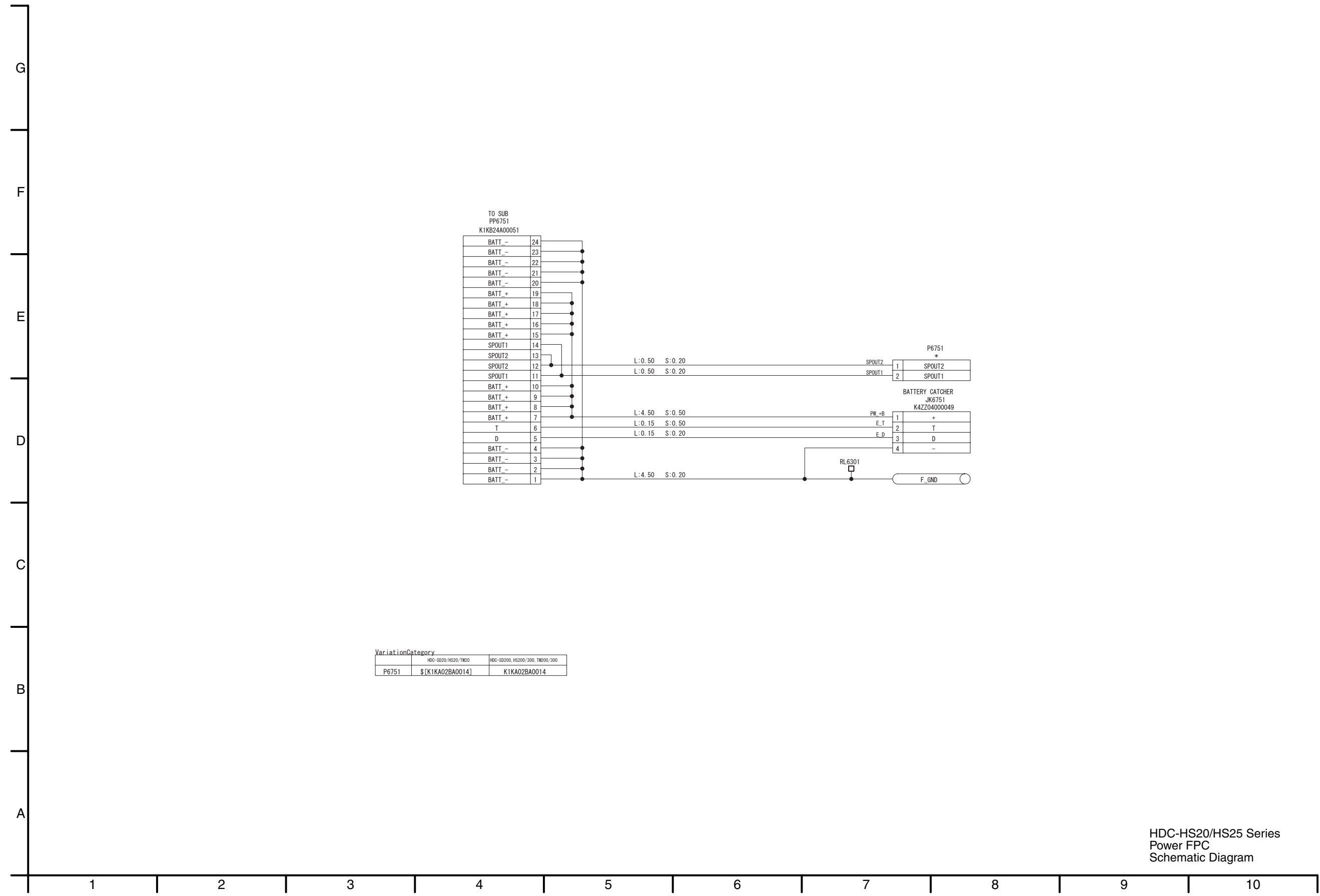

# S4.8. Main Sub FPC Schematic Diagram

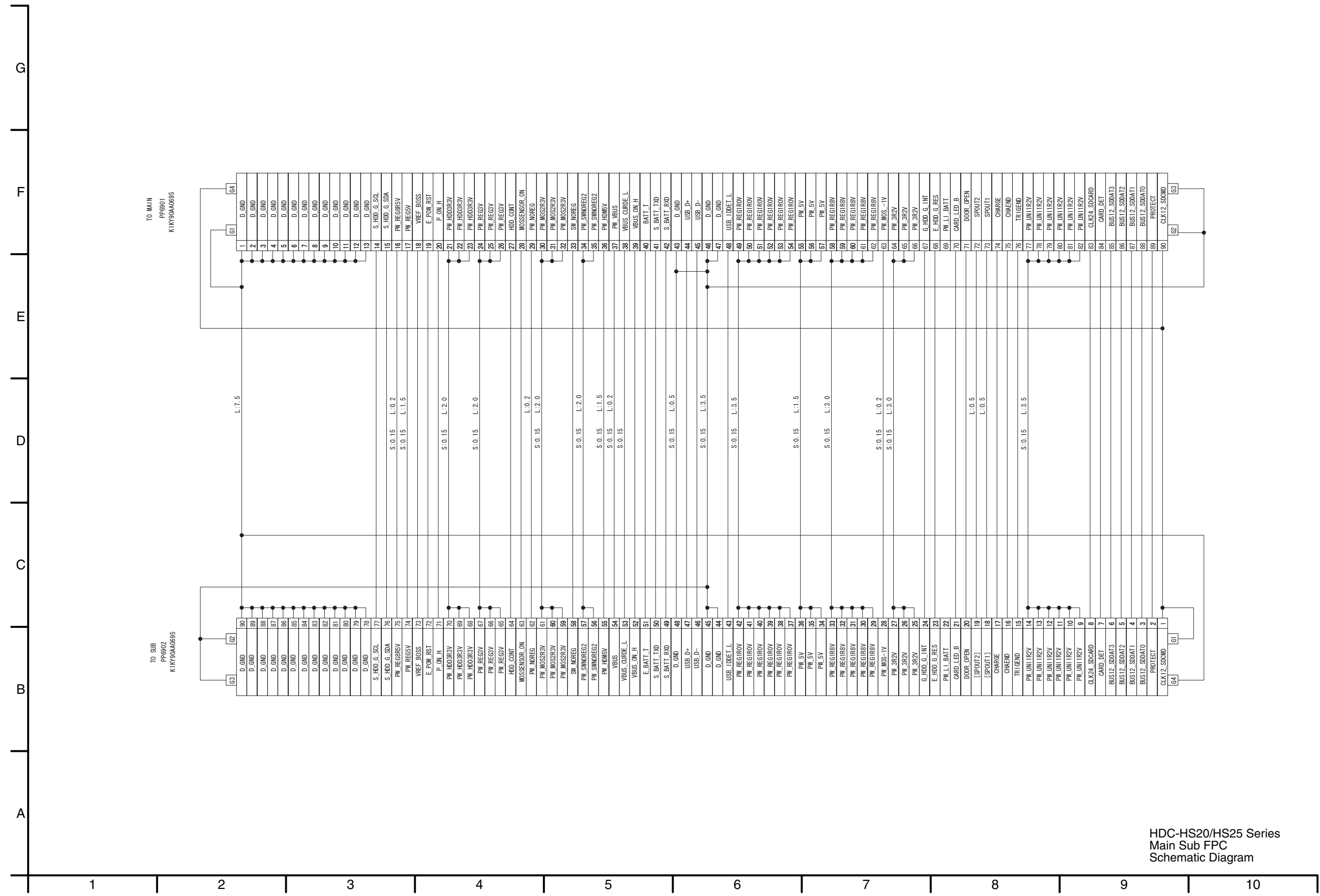

HDC-HS20/HS25 Series  
Main Sub FPC  
Schematic Diagram

# S4.9. Side R FPC Schematic Diagram

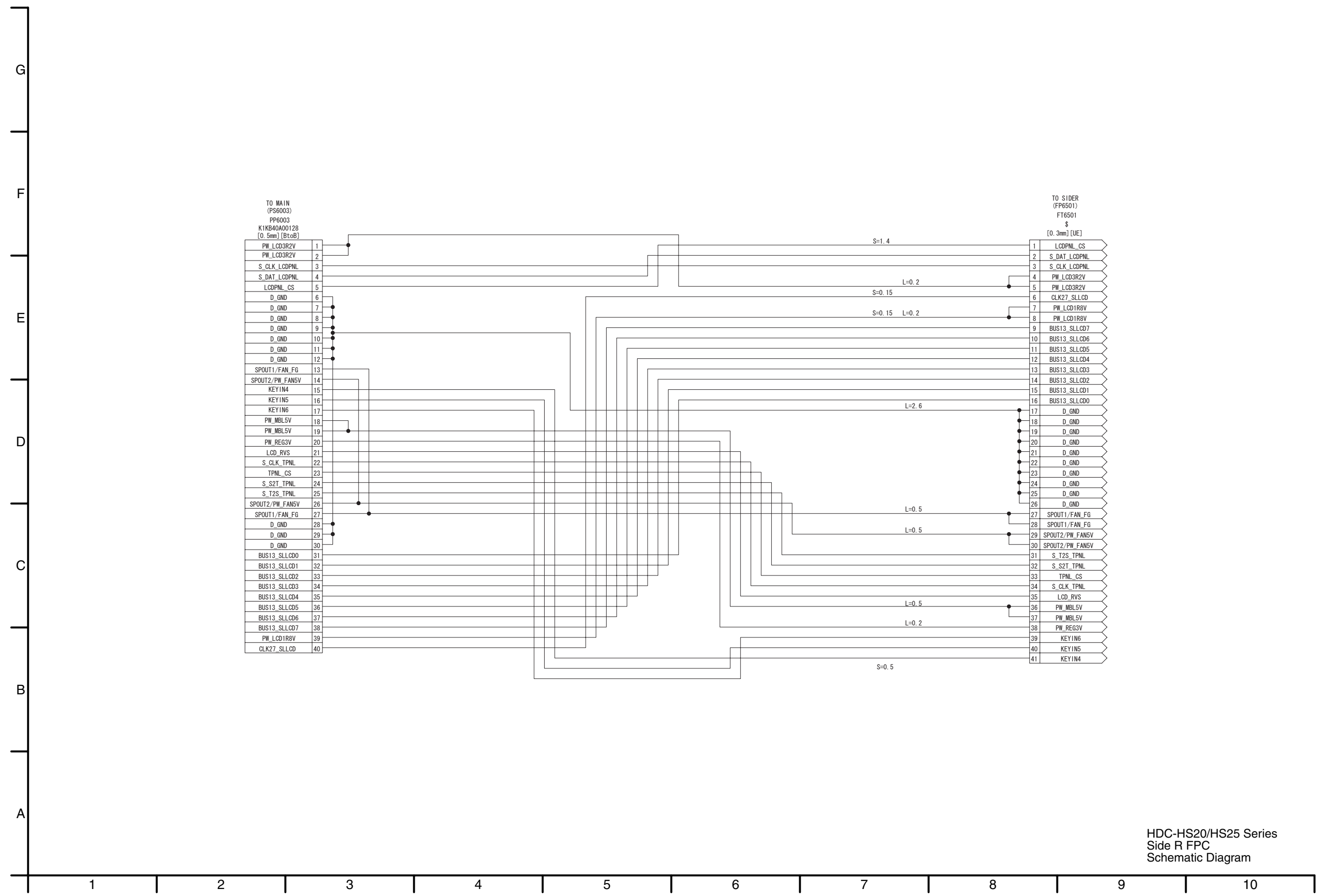

HDC-HS20/HS25 Series  
Side R FPC  
Schematic Diagram

# S4.10. Front FPC Schematic Diagram

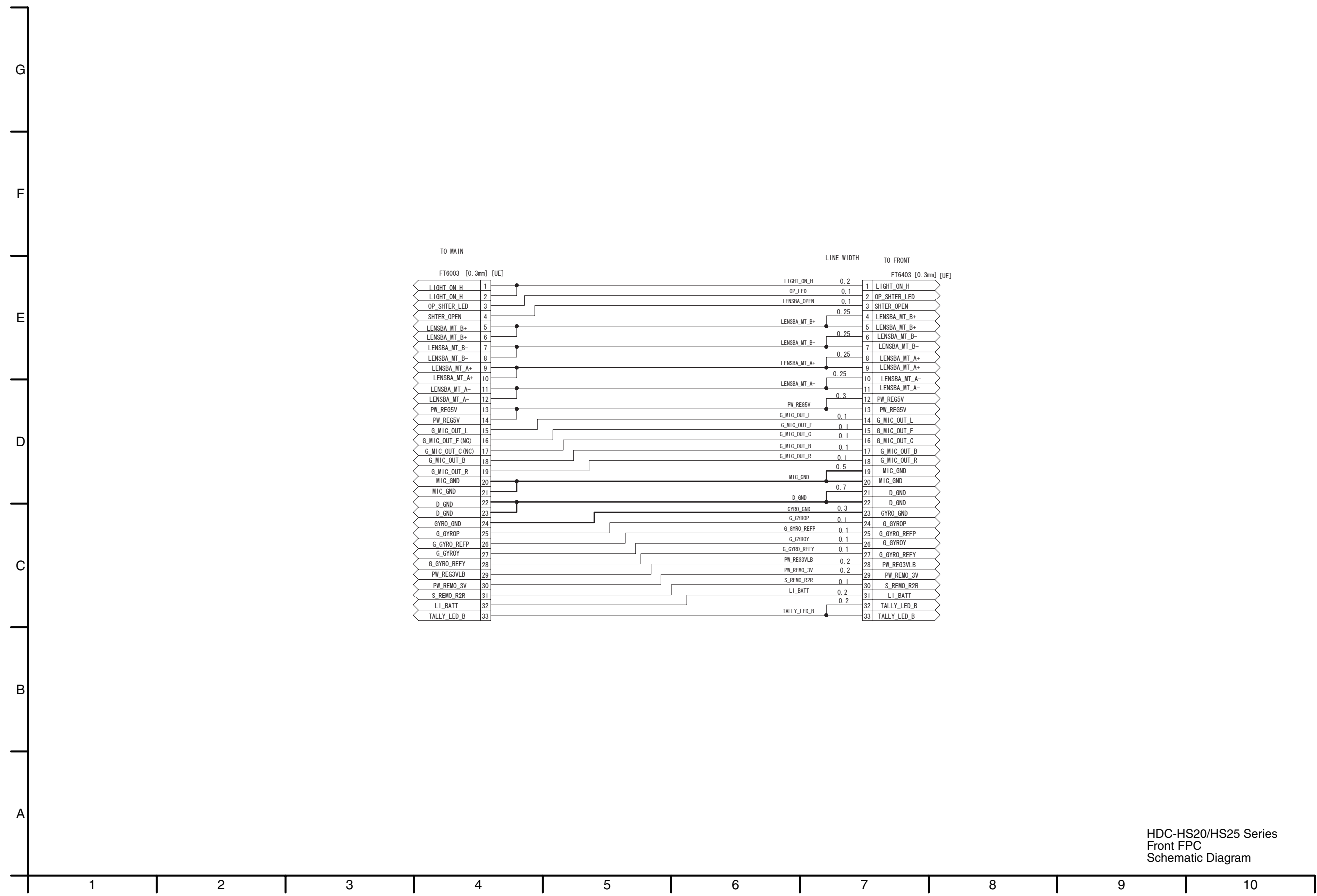

# S4.11. LCD\_OP FPC Schematic Diagram

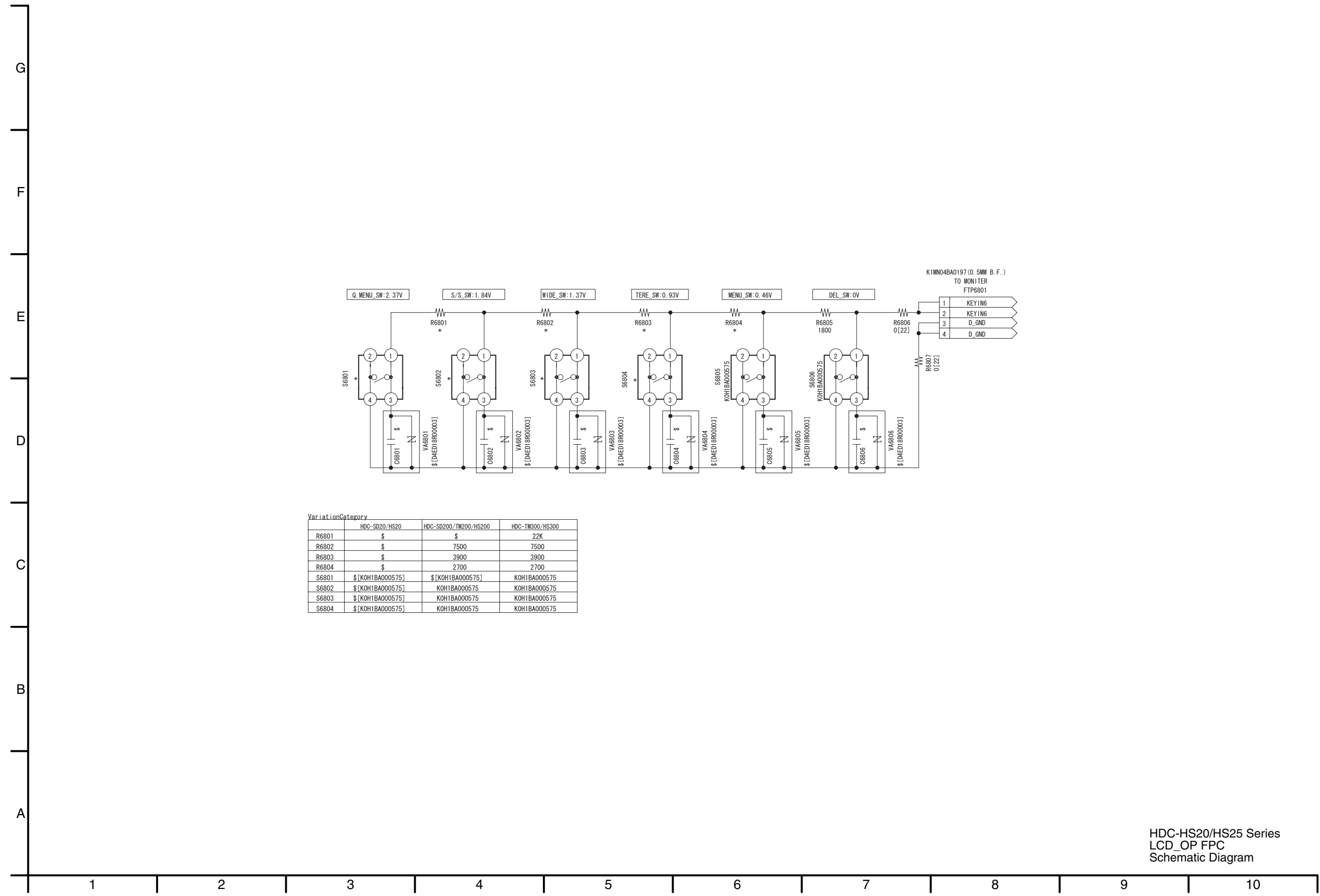

# S4.12. MOS FPC Schematic Diagram

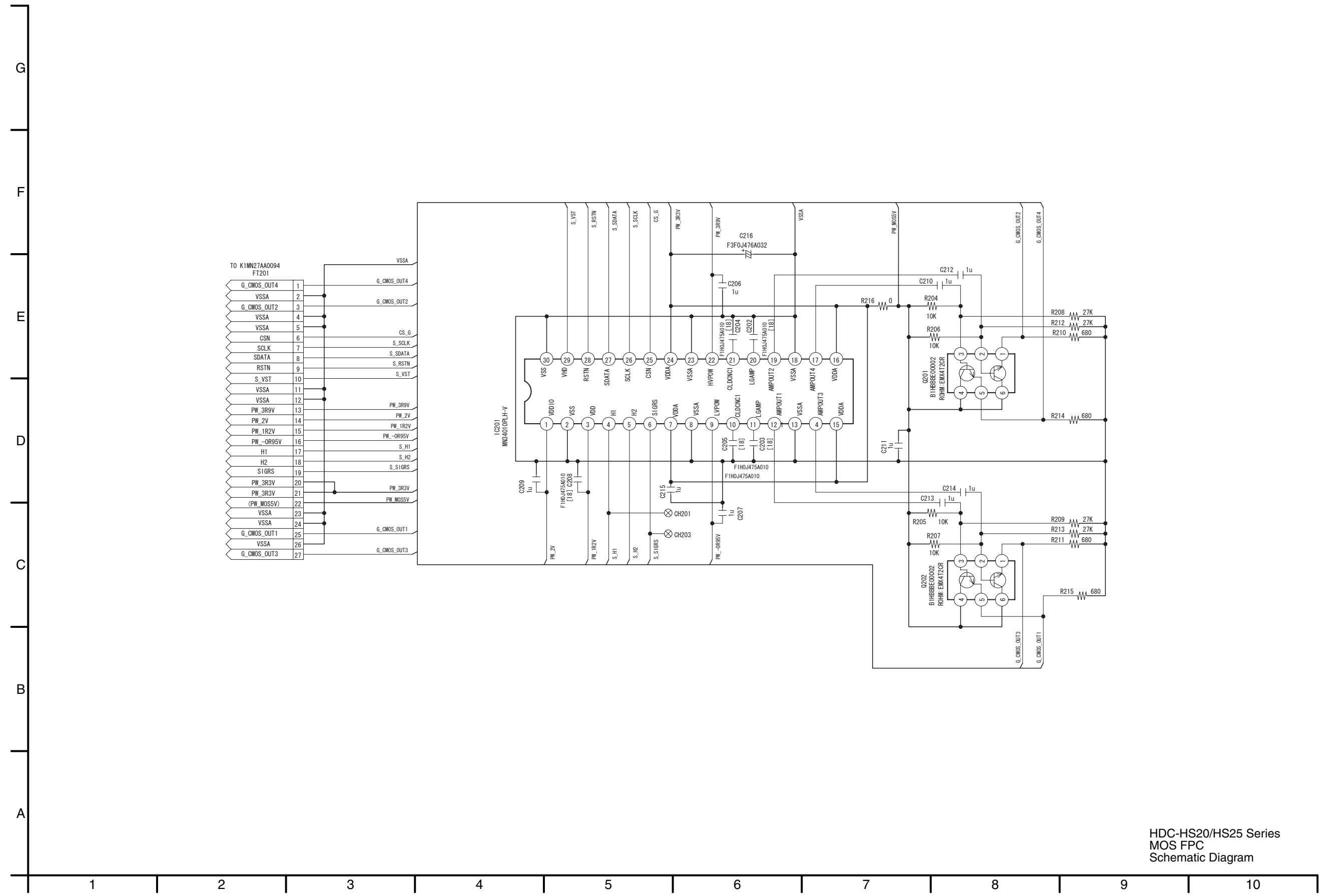

HDC-HS20/HS25 Series  
MOS FPC  
Schematic Diagram



# S4.13. HDD FPC Schematic Diagram

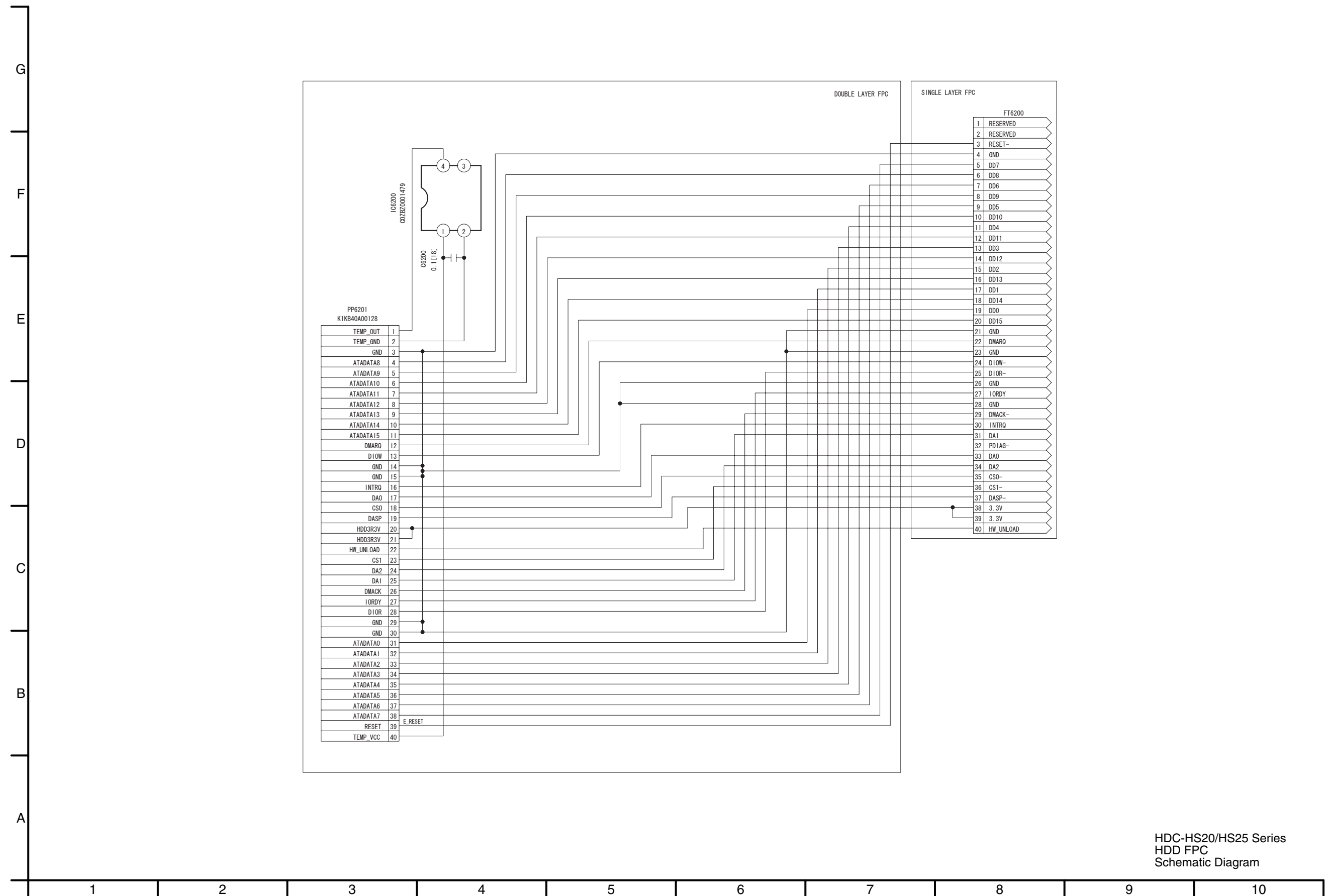

HDC-HS20/HS25 Series  
HDD FPC  
Schematic Diagram

# S5. Print Circuit Board

## S5.1. Side R P.C.B.

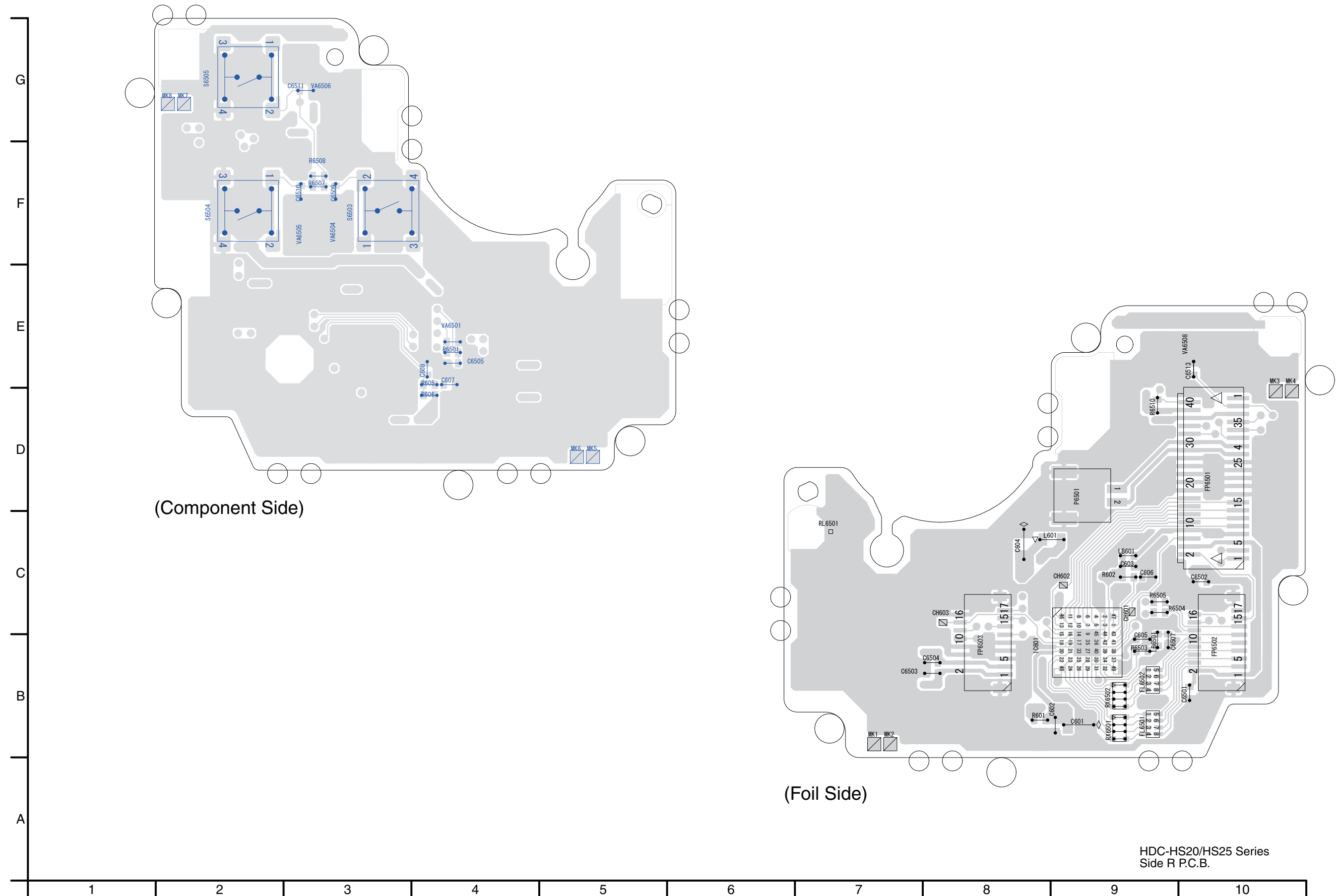

HDC-HS20/HS25 Series  
Side R P.C.B.

S5.2. Front P.C.B.

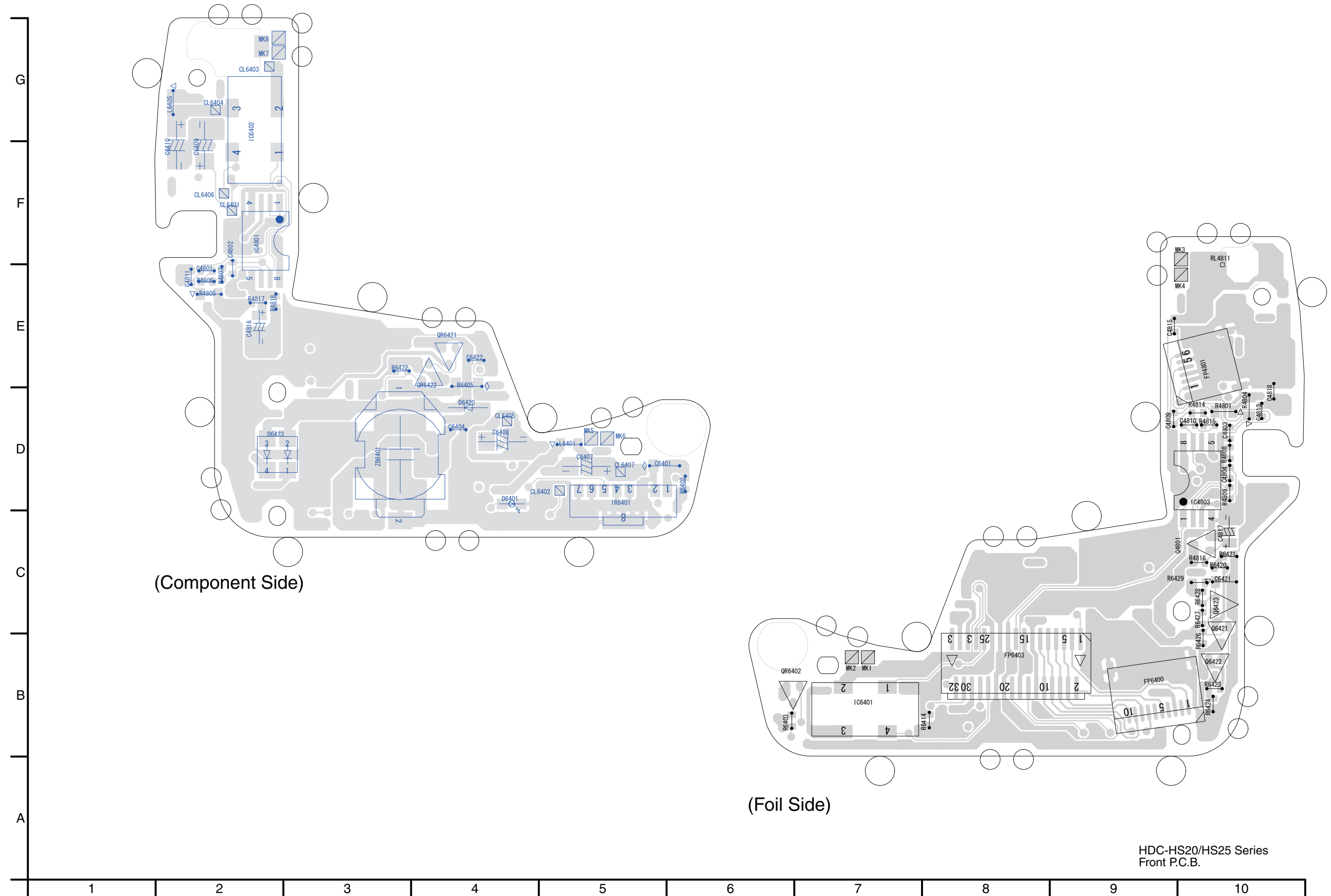

HDC-HS20/HS25 Series  
Front P.C.B.

### S5.3. Monitor P.C.B.

#### S5.3.1. Monitor P.C.B. (Component Side)

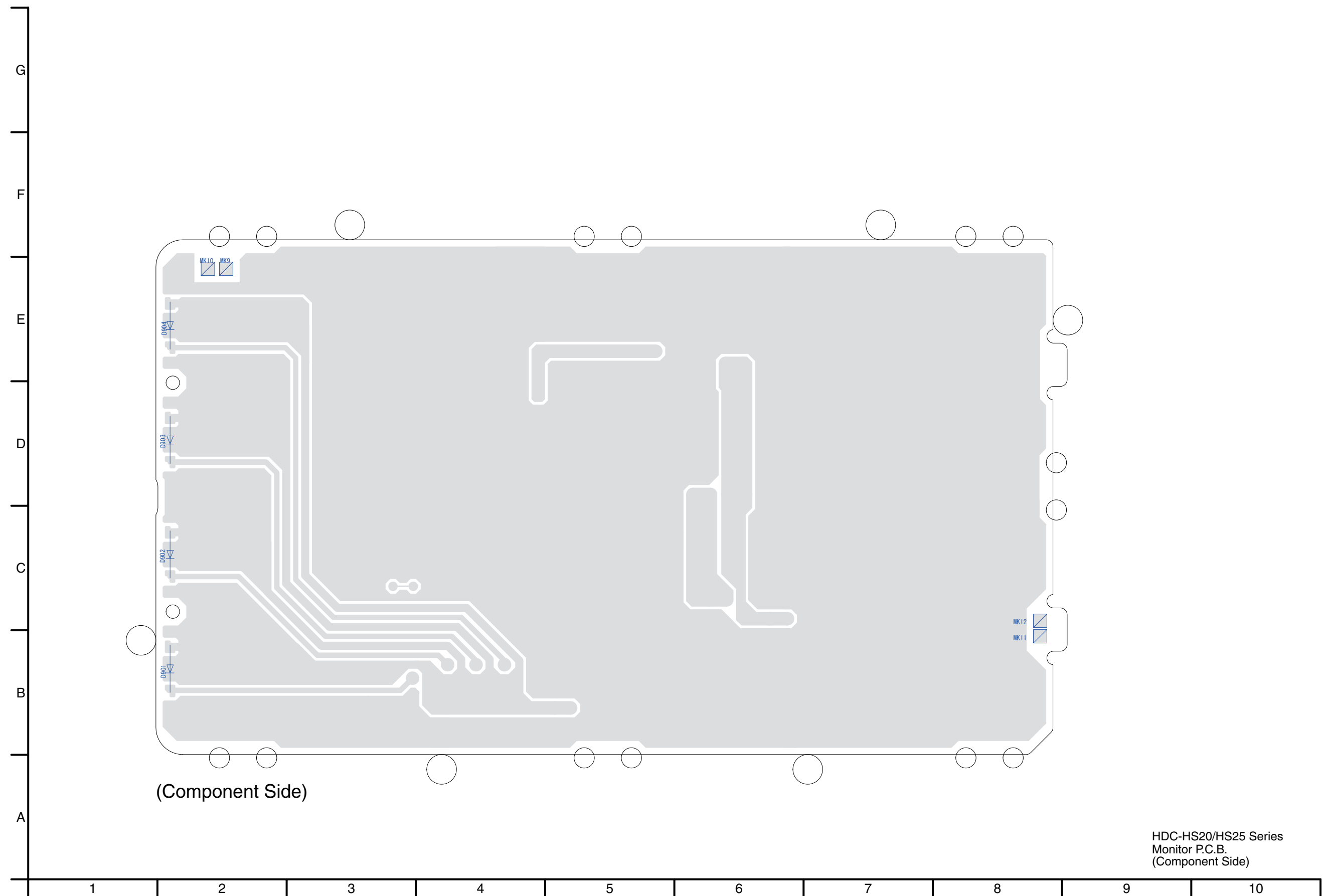

HDC-HS20/HS25 Series  
Monitor P.C.B.  
(Component Side)

S5.3.2. Monitor P.C.B. (Foil Side)

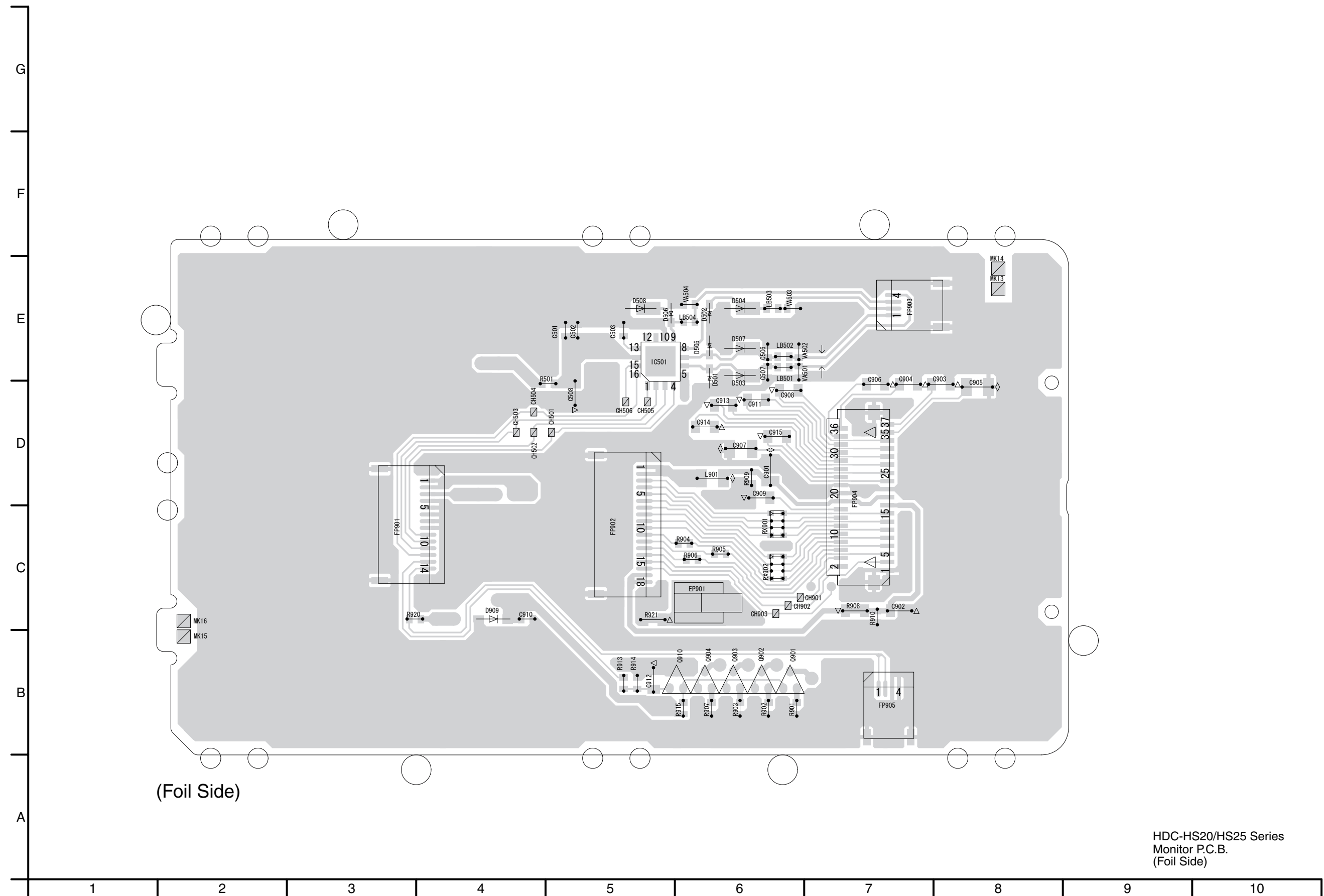

HDC-HS20/HS25 Series  
Monitor P.C.B.  
(Foil Side)

S5.4. Power FPC P.C.B.

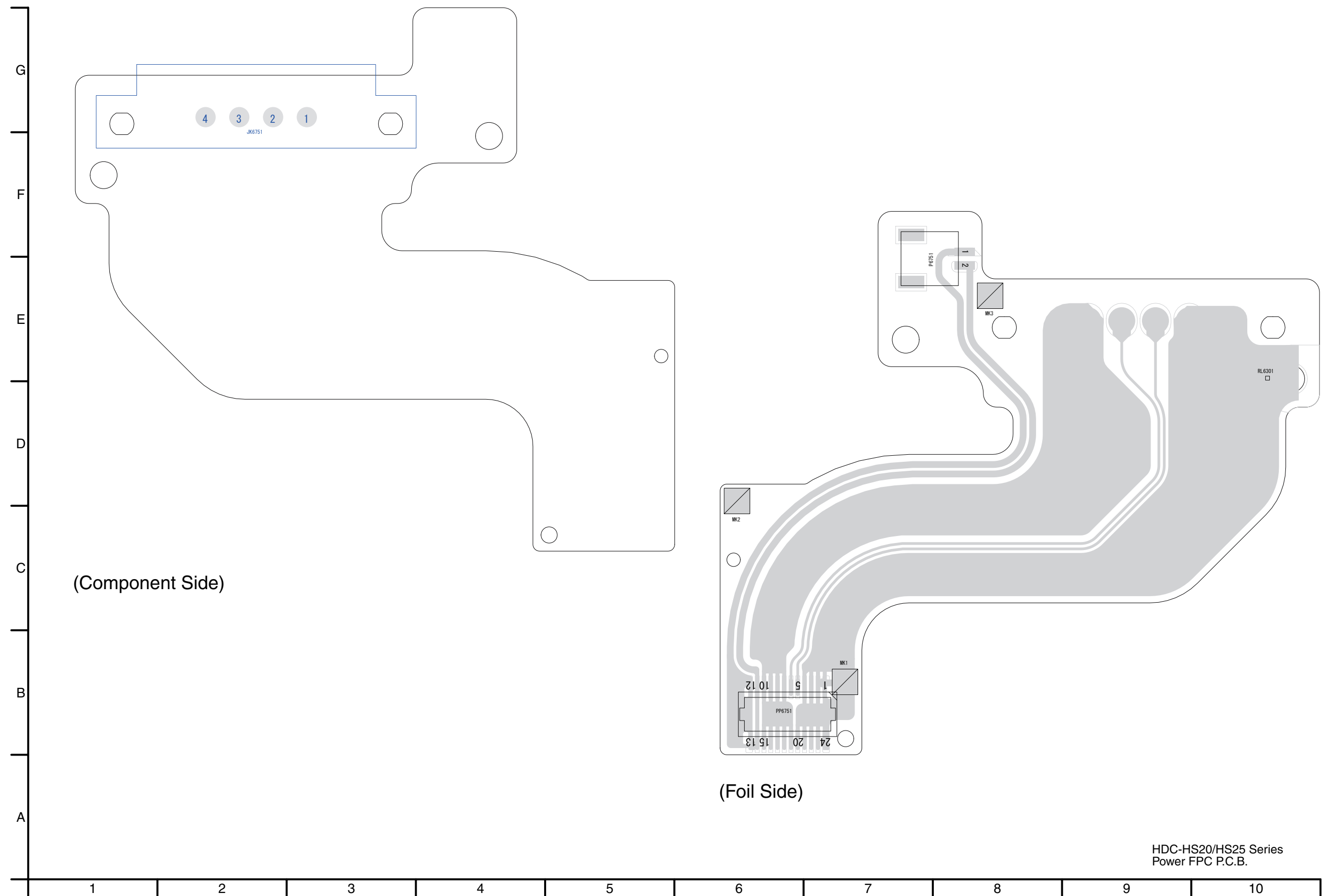

S5.5. Main Sub FPC P.C.B.

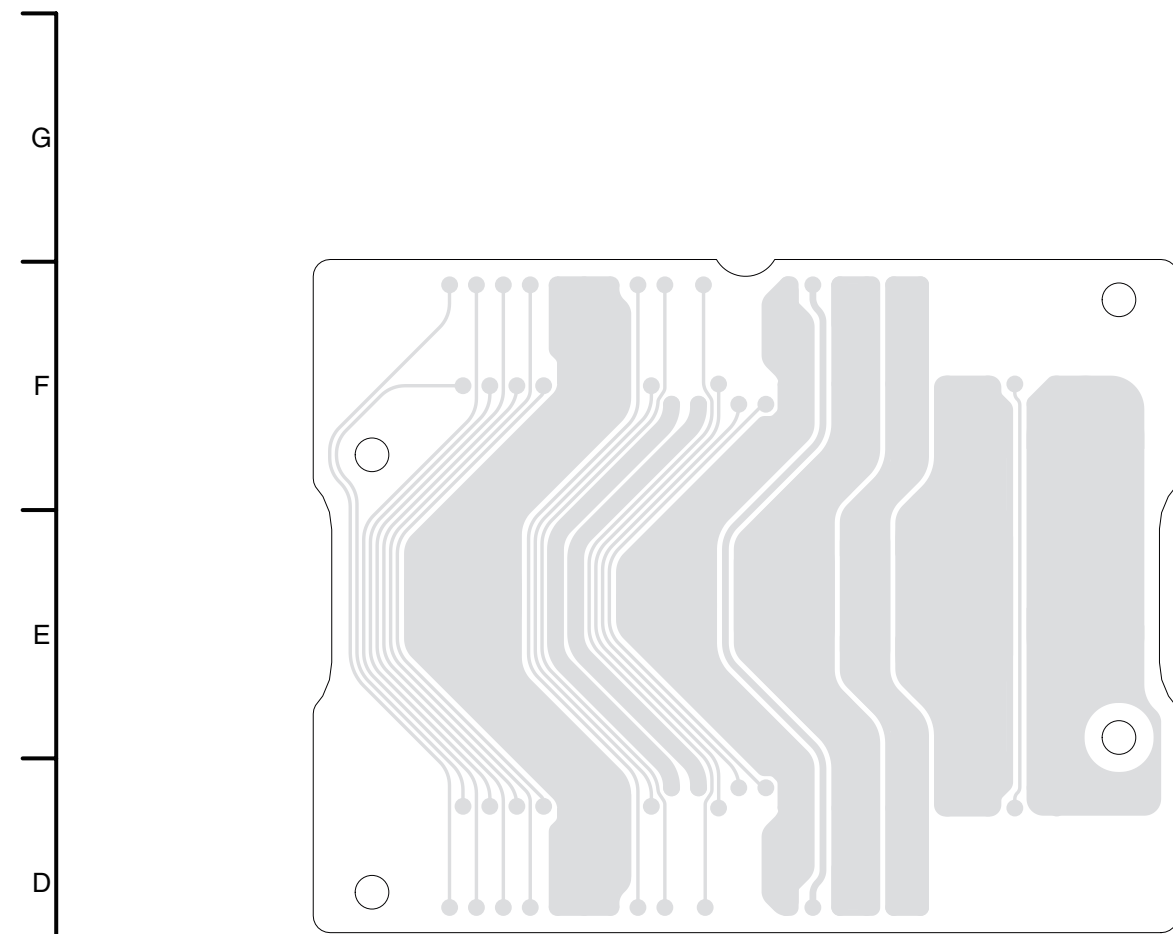

(Component Side)

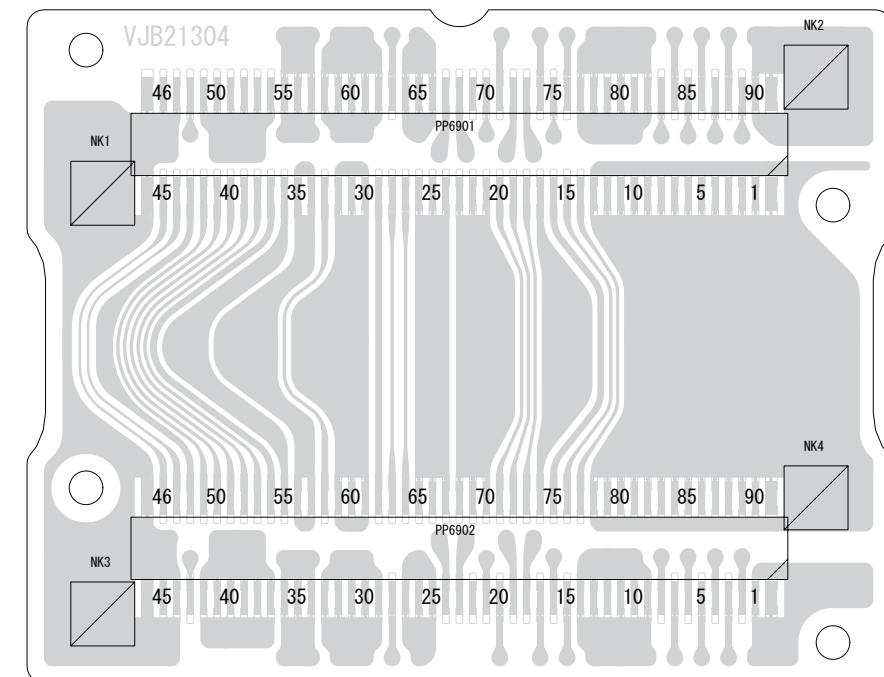

(Foil Side)

S5.6. Side R FPC P.C.B. / S5.7. Front FPC P.C.B.

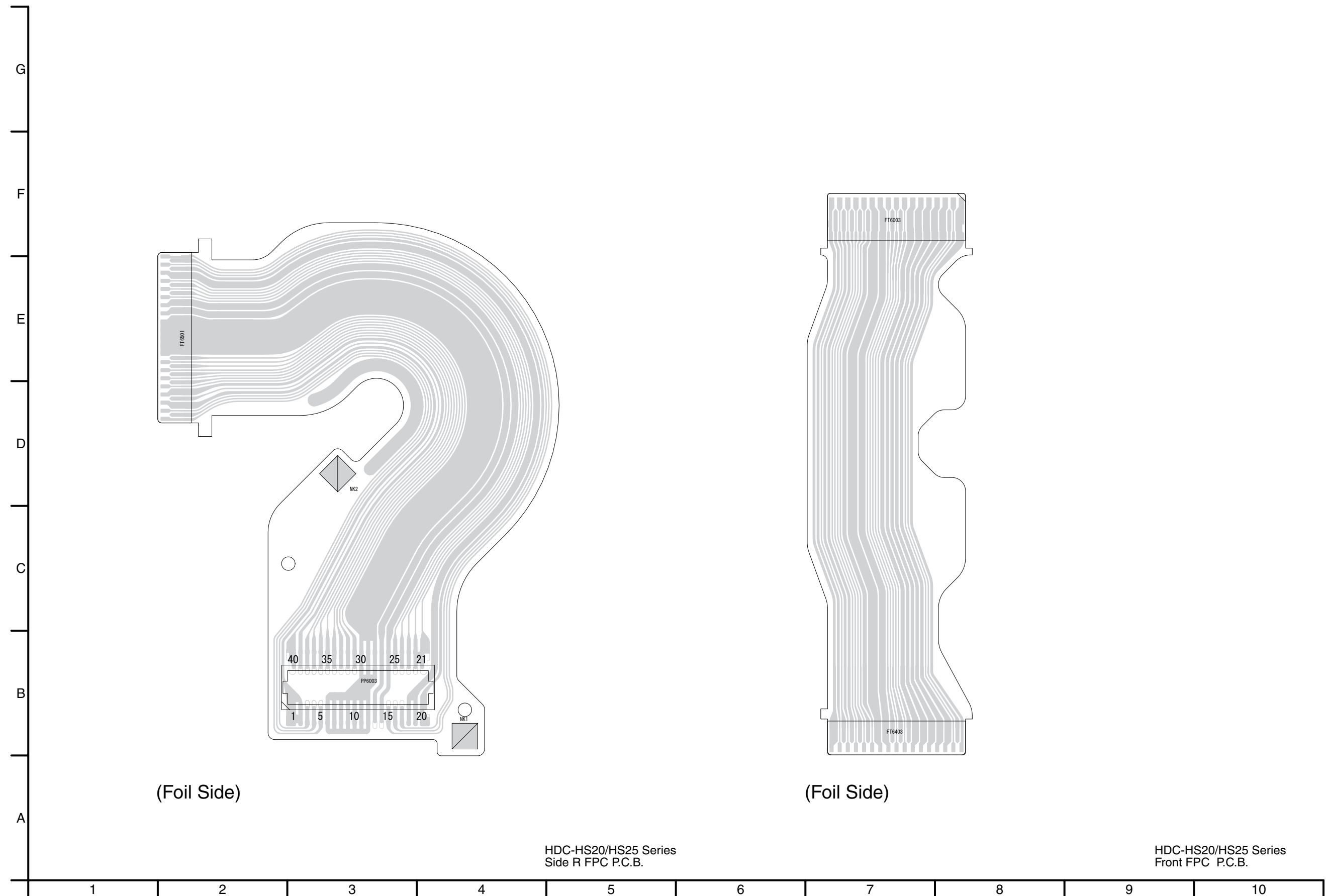



S5.8. LCD\_OP FPC P.C.B.

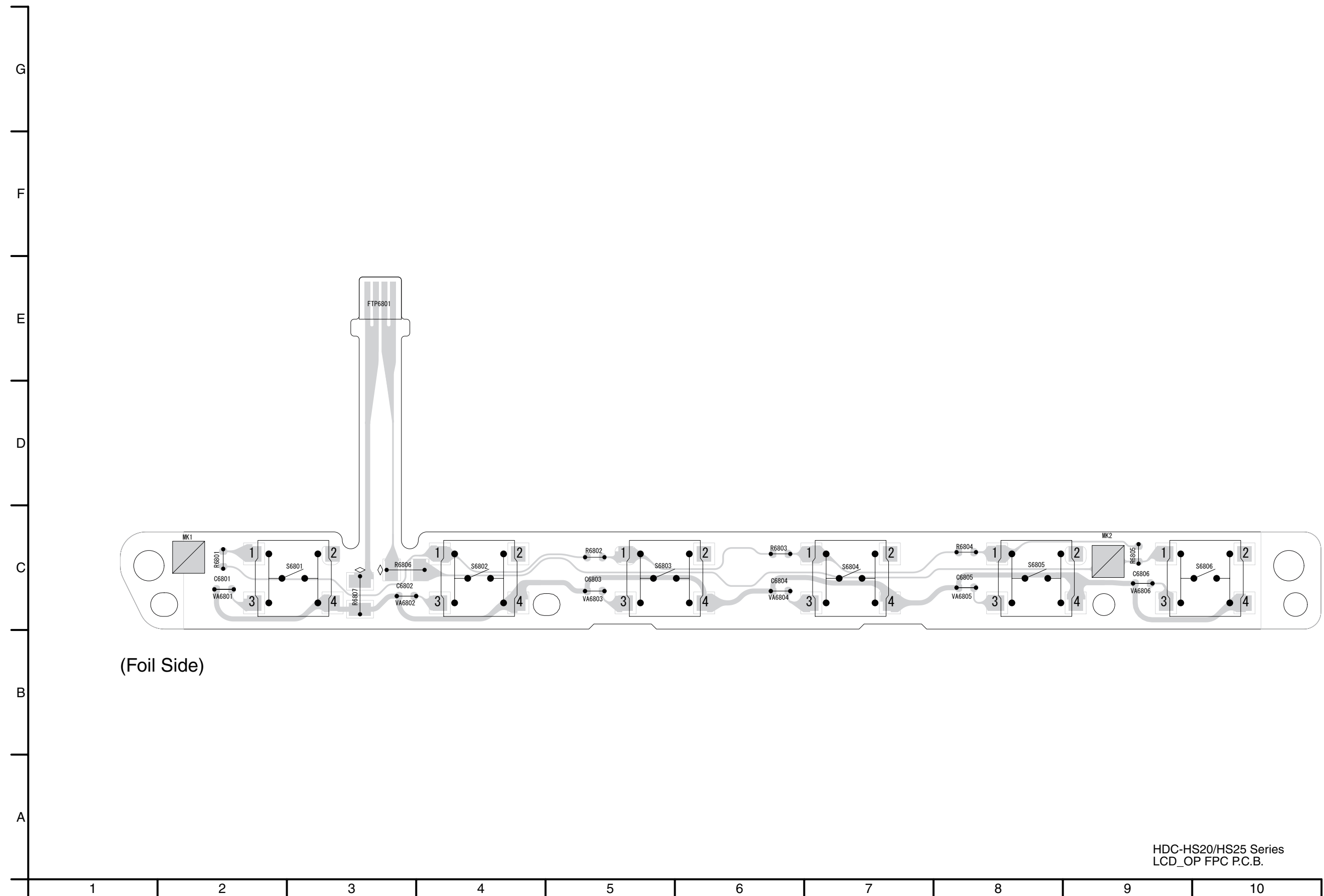

(Foil Side)

HDC-HS20/HS25 Series  
LCD\_OP FPC P.C.B.

S5.9. MOS FPC P.C.B.

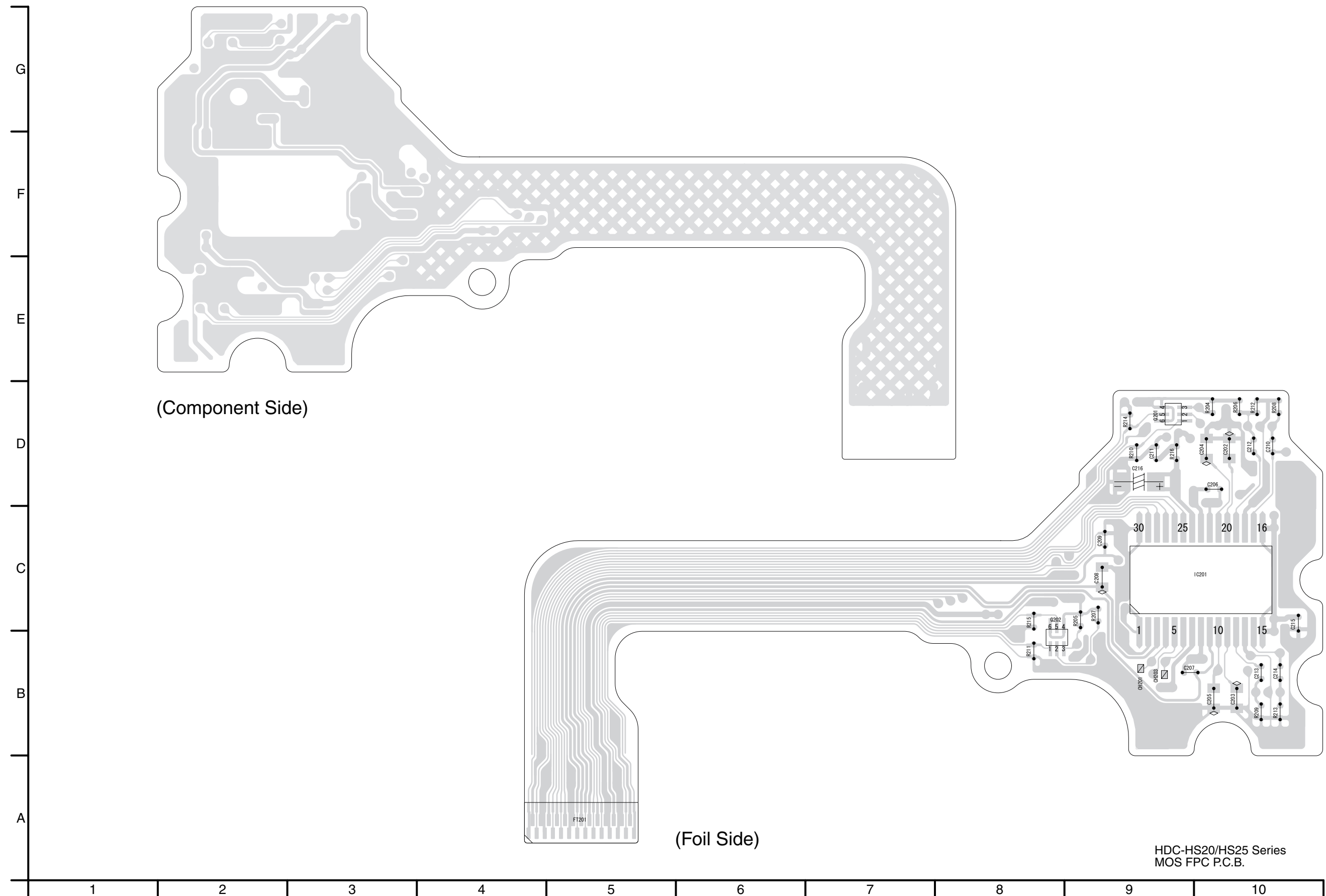

HDC-HS20/HS25 Series  
MOS FPC P.C.B.

**S5.10. HDD FPC P.C.B.**

**S5.10.1. HDD FPC P.C.B. (Component Side)**

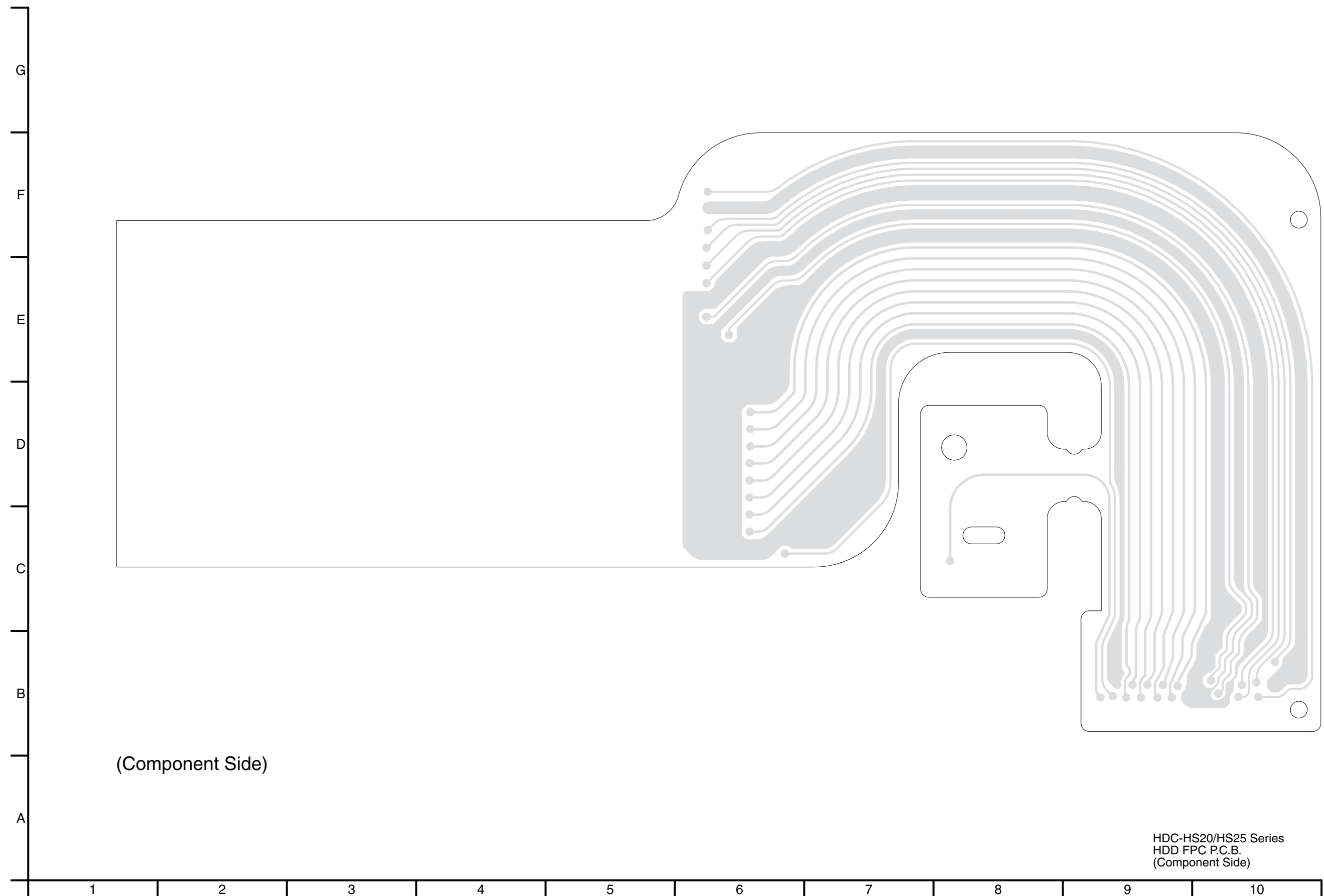

HDC-HS20/HS25 Series  
HDD FPC P.C.B.  
(Component Side)

S5.10.2. HDD FPC P.C.B. (Foil Side)

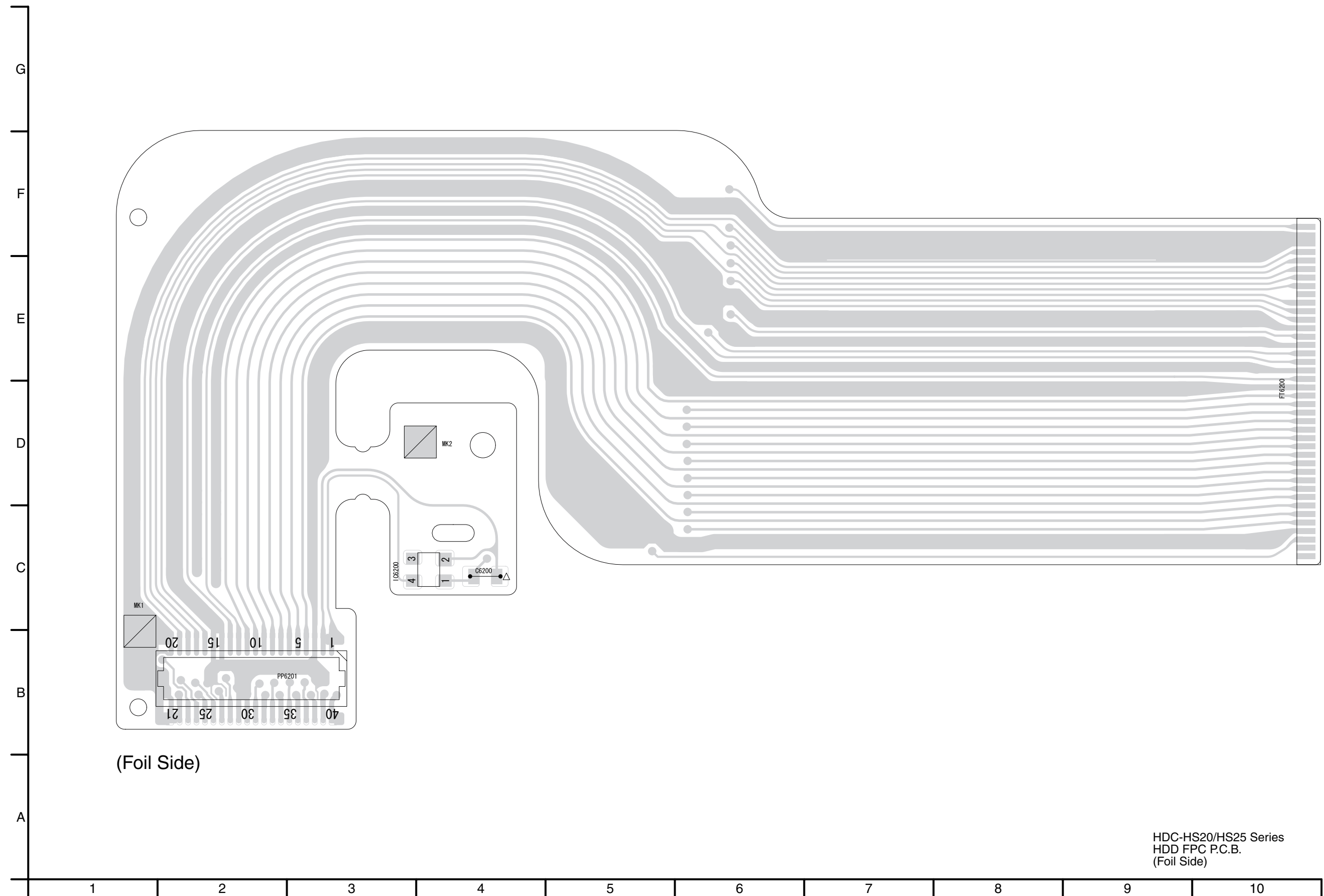



## S6. Check Point of The IC

### S6.1. Check Point of the IC601

CSP IC		Check Point	Remarks
Pin	Name		
1	SCK	-	
2	SCS	-	
3	SDI	-	
4	UCONSEL	-	
5	DIN7	-	
6	DIN6	-	
7	DIN5	-	
8	DIN4	-	
9	NC	-	
10	DIN3	-	
11	DIN2	-	
12	DIN1	-	
13	DIN0	CH602	MAIN P.C.B. (B)
14	TEST1	-	
15	HSYNC	R6505 (LEFT)	MAIN P.C.B. (B)
16	VSYNC	R6504 (LEFT)	MAIN P.C.B. (B)
17	NC	-	
18	DE	CH603	MAIN P.C.B. (B)
19	VSS	-	
20	VDD28	-	
21	DOUT7	-	
22	DOUT6	-	
23	DOUT5	-	
24	DOUT4	-	
25	DOUT3	-	
26	DOUT2	-	
27	NC	-	
28	DOUT1	-	
29	DOUT0	-	
30	VSS	-	
31	VDD28	-	
32	DCLK	R6503 (LEFT)	MAIN P.C.B. (B)
33	NC	-	
34	AVDD	R606 (RIGHT)	MAIN P.C.B. (B)
35	NC	-	
36	NC	-	
37	AVSS	-	
38	TEST2	C608 (LOWER)	MAIN P.C.B. (B)
39	CLKSEL	-	
40	PLL_VCNT	-	
41	CLKIN	CH601	MAIN P.C.B. (B)
42	VDD18	-	
43	RESET	C606 (LEFT)	MAIN P.C.B. (B)
44	VSS	-	
45	NC	-	
46	NC	-	
47	NC	-	
48	NC	-	
49	NC	-	

## S7. Replacement Parts List

- Note: 1.\* Be sure to make your orders of replacement parts according to this list.
2. IMPORTANT SAFETY NOTICE  
Components identified with the mark  $\triangle$  have the special characteristics for safety.  
When replacing any of these components, use only the same type.
3. Unless otherwise specified,  
All resistors are in OHMS, K=1,000 OHMS. All capacitors are in MICRO-FARADS (uf), P=uuF.
4. The marking (RTL) indicates the retention time is limited for this item. After the discontinuation of this assembly in production, it will no longer be available.

**E.S.D. standards for Electrostatically Sensitive Devices, refer to “PREVENTION OF ELECTROSTATIC DISCHARGE (ESD) TO ELECTROSTATICALLY SENSITIVE (ES) DEVICES” section.**

Ref.No.	Part No.	Part Name & Description	Pcs	Remarks
##	VEP03H65N	MAIN P.C.B.	1	(RTL) E.S.D.(P,PC,PU)
##	VEP03H65T	MAIN P.C.B.	1	(RTL) E.S.D.(20EB)
##	VEP03H65R	MAIN P.C.B.	1	(RTL) E.S.D.(EC,EF,EG)
##	VEP03H65W	MAIN P.C.B.	1	(RTL) E.S.D.(EE)
##	VEP03H65S	MAIN P.C.B.	1	(RTL) E.S.D.(EP)
##	VEP03H65U	MAIN P.C.B.	1	(RTL) E.S.D.(GC,SG)
##	VEP03H65V	MAIN P.C.B.	1	(RTL) E.S.D.(GJ)
##	VEP03H65Y	MAIN P.C.B.	1	(RTL) E.S.D.(GK)
##	VEP03H65X	MAIN P.C.B.	1	(RTL) E.S.D.(GN)
##	VEP03H65Q	MAIN P.C.B.	1	(RTL) E.S.D.(GT)
##	VEP03H65AM	MAIN P.C.B.	1	(RTL) E.S.D.(25EB)
##	VEP01A16B	SUB P.C.B.	1	(RTL) E.S.D.
##	VEP29209A	SIDE (R) P.C.B.	1	(RTL) E.S.D.
##	VEP20C47A	FRONT P.C.B.	1	(RTL) E.S.D.
##	VEP26321A	MONITOR P.C.B.	1	(RTL) E.S.D.
##	VEP22399A	MOS FPC	1	(RTL) E.S.D.
##	VEP79227A	HDD FPC	1	(RTL) E.S.D.
##	VEP29209A	SIDE (R) P.C.B.	1	(RTL) E.S.D.
C601	F1J0J1060009	C.CAPACITOR CH 6.3V 10U	1	
C602	F1G1C104A080	C.CAPACITOR CH 16V 0.1U	1	
C603	ECJ0EB1A473K	C.CAPACITOR CH 10V 0.047U	1	
C604	F1J0J1060009	C.CAPACITOR CH 6.3V 10U	1	
C605	F1G1C104A080	C.CAPACITOR CH 16V 0.1U	1	
C606	F1G1C104A080	C.CAPACITOR CH 16V 0.1U	1	
C607	ECJ0EB1C103K	C.CAPACITOR CH 16V 0.01U	1	
C6501	F1G1C104A080	C.CAPACITOR CH 16V 0.1U	1	
C6502	F1G1C104A080	C.CAPACITOR CH 16V 0.1U	1	
C6503	F1G1C104A080	C.CAPACITOR CH 16V 0.1U	1	
C6504	F1G1C104A080	C.CAPACITOR CH 16V 0.1U	1	
C6505	F1G1C104A080	C.CAPACITOR CH 16V 0.1U	1	
C6507	ECJ0EC1H050C	C.CAPACITOR CH 50V 5P	1	
C6509	ECJ0EB1C103K	C.CAPACITOR CH 16V 0.01U	1	
C6510	ECJ0EB1C103K	C.CAPACITOR CH 16V 0.01U	1	
C6511	ECJ0EB1C103K	C.CAPACITOR CH 16V 0.01U	1	
C6513	ECJ0EB1C103K	C.CAPACITOR CH 16V 0.01U	1	
FL6501	J0JAD0000028	FILTER	1	
FL6502	J0JAD0000028	FILTER	1	
FP6501	K1MN41BA0259	CONNECTOR 41P	1	
FP6502	K1MN17AA0035	CONNECTOR 17P	1	
FP6503	K1MN17AA0035	CONNECTOR 17P	1	
IC601	C1AB00003017	IC	1	E.S.D.
L601	G1C100KA0115	CHIP INDUCTOR 10UH	1	
LB601	J0JYC0000059	FILTER	1	
LB6501	J0JBC0000115	FILTER	1	
P6501	K1KA02BA0014	CONNECTOR 2P	1	
R602	ERJ2GEJ104	M.RESISTOR CH 1/16W 100K	1	
R605	ERJ2GEJ221	M.RESISTOR CH 1/16W 220	1	
R6501	ERJ2GEJ102X	M.RESISTOR CH 1/16W 1K	1	
R6503	ERJ2GEJ820	M.RESISTOR CH 1/16W 82	1	
R6504	ERJ2GEJ820	M.RESISTOR CH 1/16W 82	1	
R6505	ERJ2GEJ820	M.RESISTOR CH 1/16W 82	1	
R6507	ERJ2GEJ392	M.RESISTOR CH 1/16W 3.9K	1	
R6508	ERJ2GEJ302	M.RESISTOR CH 1/16W 3K	1	
R6510	ERJ2GEJ103	M.RESISTOR CH 1/16W 10K	1	
RX6501	D1H81214A024	RESISTOR	1	
RX6502	D1H81214A024	RESISTOR	1	
S6503	K0H1BA000436	SWITCH, LIGHT	1	
S6504	K0H1BA000436	SWITCH, MANUAL	1	
S6505	K0H1BA000436	SWITCH, OIS	1	
VA6501	D4ED18R00003	VARISTORS	1	

Ref.No.	Part No.	Part Name & Description	Pcs	Remarks
##	VEP20C47A	FRONT P.C.B.	1	(RTL) E.S.D.
△ B6401	ML-614S/ZT	BATTERY	1	[Energy]
C4801	ECJ0EB1A473K	C.CAPACITOR CH 10V 0.047U	1	
C4802	ECJ0EC1H680J	C.CAPACITOR CH 50V 68P	1	
C4803	ECJ0EB1A473K	C.CAPACITOR CH 10V 0.047U	1	
C4804	ECJ0EC1H680J	C.CAPACITOR CH 50V 68P	1	
C4809	ECJ0EB1A473K	C.CAPACITOR CH 10V 0.047U	1	
C4810	ECJ0EC1H680J	C.CAPACITOR CH 50V 68P	1	
C4816	F3E0J106A009	E.CAPACITOR CH 6.3V 22U	1	
C4817	F3E0J106A009	E.CAPACITOR CH 6.3V 22U	1	
C4818	F1G0J1050007	C.CAPACITOR CH 6.3V 1U	1	
C6401	F1J0J106A049	C.CAPACITOR CH 6.3V 10U	1	
C6404	F1G1C104A080	C.CAPACITOR CH 16V 0.1U	1	
C6407	F3F0J476A032	E.CAPACITOR CH 6.3V 47U	1	
C6408	F3F0J226A032	T.CAPACITOR CH 6.3V 22U	1	
C6409	F3F0J226A032	T.CAPACITOR CH 6.3V 22U	1	
C6410	F3F0J476A032	E.CAPACITOR CH 6.3V 47U	1	
C6421	F1H0J475A010	C.CAPACITOR CH 6.3V 4.7U	1	
C6422	F1G1C104A080	C.CAPACITOR CH 16V 0.1U	1	
D6401	B3AAB0000137	LED	1	E.S.D.
D6420	MAZ8062GML	DIODE	1	E.S.D.
D6423	B3AFB0000278	LED	1	E.S.D.
FP4801	K1MN06BA0197	CONNECTOR 6P	1	
FP6400	K1MN10BA0197	CONNECTOR 10P	1	
FP6403	K1MN33BA0259	CONNECTOR 33P	1	
IC4801	C0ABBB000369	IC	1	E.S.D.
IC4803	C0ABBB000369	IC	1	E.S.D.
IC6401	L2ES00000018	IC	1	E.S.D.
IC6402	L2ES00000019	IC	1	E.S.D.
IR6401	B3RBB0000013	REMOTE SENSOR	1	
L6401	G1C100KA0115	CHIP INDUCTOR 10UH	1	
L6405	G1C100KA0115	CHIP INDUCTOR 10UH	1	
Q4801	2SD2216J0L	TRANSISTOR	1	E.S.D.
Q6421	2SC6054J0L	TRANSISTOR	1	E.S.D.
Q6422	2SC6054J0L	TRANSISTOR	1	E.S.D.
Q6423	2SA2174J0L	TRANSISTOR	1	E.S.D.
QR6402	UNR91AFJ0L	RESISTOR-TRANSISTOR	1	E.S.D.
QR6421	UNR91ATJ0L	RESISTOR-TRANSISTOR	1	E.S.D.
QR6422	UNR92A5J0L	RESISTOR-TRANSISTOR	1	E.S.D.
R4801	VRE0071E392	M.RESISTOR CH 1/10W 3.9K	1	
R4804	VRE0071E392	M.RESISTOR CH 1/10W 3.9K	1	
R4805	VRE0071E392	M.RESISTOR CH 1/10W 3.9K	1	
R4806	ERJ2GEJ183	M.RESISTOR CH 1/16W 18K	1	
R4807	ERJ2GEJ683	M.RESISTOR CH 1/16W 68K	1	
R4808	ERJ2GEJ183	M.RESISTOR CH 1/16W 18K	1	
R4809	ERJ2GEJ683	M.RESISTOR CH 1/16W 68K	1	
R4814	ERJ2GEJ183	M.RESISTOR CH 1/16W 18K	1	
R4815	ERJ2GEJ683	M.RESISTOR CH 1/16W 68K	1	
R4816	ERJ2GEJ472	M.RESISTOR CH 1/16W 4.7K	1	
R4817	ERJ2GEJ223	M.RESISTOR CH 1/16W 22K	1	
R4818	ERJ2GEJ333	M.RESISTOR CH 1/16W 33K	1	
R6402	ERJ2RKD330	M.RESISTOR CH 1/16W 33	1	
R6403	ERJ2GEJ101	M.RESISTOR CH 1/16W 100	1	
R6405	ERJ6GEYJ222V	M.RESISTOR CH 1/10W 2.2K	1	
R6414	D0YAR0000007	M.RESISTOR CH 1/16W 0	1	
R6420	ERJ2RKD240	M.RESISTOR CH 1/16W 24	1	
R6421	ERJ2RKD240	M.RESISTOR CH 1/16W 24	1	
R6423	ERJ2RKD240	M.RESISTOR CH 1/16W 24	1	
R6424	ERJ2RKD240	M.RESISTOR CH 1/16W 24	1	
R6426	ERJ2GEJ472	M.RESISTOR CH 1/16W 4.7K	1	
R6427	ERJ2RHD333X	M.RESISTOR CH 1/16W 33K	1	
R6428	ERJ2RHD471X	M.RESISTOR CH 1/16W 470	1	
R6429	ERJ2RHD562	M.RESISTOR CH 1/16W 5.6K	1	
ZB6401	K3ZZ00500014	CONNECTOR	1	



Ref.No.	Part No.	Part Name & Description	Pcs	Remarks
##	VEP26321A	MONITOR P.C.B.		(RTL) E.S.D.
C501	F1G0J1050007	C.CAPACITOR CH 6.3V 1U	1	
C502	F1G1A104A012	C.CAPACITOR CH 10V 0.1U	1	
C503	F1G1A104A012	C.CAPACITOR CH 10V 0.1U	1	
C506	F1G1H1020008	C.CAPACITOR CH 50V 1000P	1	
C507	F1G1H1020008	C.CAPACITOR CH 50V 1000P	1	
C901	F1J0J1060009	C.CAPACITOR CH 6.3V 10U	1	
C902	F1H0J225A002	C.CAPACITOR CH 6.3V 2.2U	1	
C903	F1H1A225A051	C.CAPACITOR CH 10V 2.2U	1	
C904	F1H1A225A051	C.CAPACITOR CH 10V 2.2U	1	
C905	F1J1C2250012	C.CAPACITOR CH 16V 2.2U	1	
C906	F1H1A225A051	C.CAPACITOR CH 10V 2.2U	1	
C907	F1J1C2250012	C.CAPACITOR CH 16V 2.2U	1	
C908	ECJ1VB1C105K	C.CAPACITOR CH 16V 1U	1	
C909	F1H1A225A051	C.CAPACITOR CH 10V 2.2U	1	
C910	F1G1C104A080	C.CAPACITOR CH 16V 0.1U	1	
C911	ECJ1VB1C105K	C.CAPACITOR CH 16V 1U	1	
C912	F1H0J475A010	C.CAPACITOR CH 6.3V 4.7U	1	
C913	ECJ1VB1C105K	C.CAPACITOR CH 16V 1U	1	
C914	ECJ1VB1C105K	C.CAPACITOR CH 16V 1U	1	
C915	ECJ1VB1C105K	C.CAPACITOR CH 16V 1U	1	
D501	MA2SD320GL	DIODE	1	E.S.D.
D502	MA2SD320GL	DIODE	1	E.S.D.
D901	B3AFB0000247	LED	1	E.S.D.
D902	B3AFB0000247	LED	1	E.S.D.
D903	B3AFB0000247	LED	1	E.S.D.
D904	B3AFB0000247	LED	1	E.S.D.
D909	MAZ8062GML	DIODE	1	E.S.D.
EP901	K4AD01D00008	TERMINAL BLOCK	1	
FP901	K1MN14BA0197	CONNECTOR 14P	1	
FP902	K1MN18BA0197	CONNECTOR 18P	1	
FP903	K1MN04BA0262	CONNECTOR 4P	1	
FP904	K1MY37BA0235	CONNECTOR 37P	1	
FP905	K1MN04BA0197	CONNECTOR 4P	1	
IC501	C1ZB20003885	IC	1	E.S.D.
L901	G1C101KA0055	CHIP INDUCTOR 100UH	1	
LB501	J0JCC0000276	FILTER	1	
LB502	J0JCC0000276	FILTER	1	
LB503	J0JCC0000276	FILTER	1	
LB504	J0JCC0000276	FILTER	1	
Q901	2SC6054J0L	TRANSISTOR	1	E.S.D.
Q902	2SC6054J0L	TRANSISTOR	1	E.S.D.
Q903	2SC6054J0L	TRANSISTOR	1	E.S.D.
Q904	2SC6054J0L	TRANSISTOR	1	E.S.D.
Q910	2SA2174J0L	TRANSISTOR	1	E.S.D.
R501	D0YAR0000007	M.RESISTOR CH 1/16W 0	1	
R901	ERJ2RKD220	M.RESISTOR CH 1/16W 22	1	
R902	ERJ2RKD220	M.RESISTOR CH 1/16W 22	1	
R903	ERJ2RKD220	M.RESISTOR CH 1/16W 22	1	
R907	ERJ2RKD220	M.RESISTOR CH 1/16W 22	1	
R909	ERJ2GEJ472	M.RESISTOR CH 1/16W 4.7K	1	
R910	ERJ2RHD272	M.RESISTOR CH 1/16W 2.7K	1	
R913	ERJ2RHD183	M.RESISTOR CH 1/16W 18K	1	
R914	ERJ2GED113X	M.RESISTOR CH 1/16W 11K	1	
R915	ERJ2GEJ152	M.RESISTOR CH 1/16W 1.5K	1	
R920	ERJ2GEJ103	M.RESISTOR CH 1/16W 10K	1	
RX901	D1H83314A024	RESISTOR	1	
RX902	D1H83314A024	RESISTOR	1	
VA501	D4ED1270A011	VARISTORS	1	
VA502	D4ED1270A011	VARISTORS	1	
VA503	D4ED18R00008	VARISTORS	1	
VA504	D4ED18R00008	VARISTORS	1	

Ref.No.	Part No.	Part Name & Description	Pcs	Remarks
##	VEP22399A	MOS FPC		(RTL) E.S.D.
C202	F1H0J475A010	C.CAPACITOR CH 6.3V 4.7U	1	
C203	F1H0J475A010	C.CAPACITOR CH 6.3V 4.7U	1	
C204	F1H0J475A010	C.CAPACITOR CH 6.3V 4.7U	1	
C205	F1H0J475A010	C.CAPACITOR CH 6.3V 4.7U	1	
C206	F1G0J1050007	C.CAPACITOR CH 6.3V 1U	1	
C207	F1G0J1050007	C.CAPACITOR CH 6.3V 1U	1	
C208	F1H0J475A010	C.CAPACITOR CH 6.3V 4.7U	1	
C209	F1G0J1050007	C.CAPACITOR CH 6.3V 1U	1	
C210	F1G0J1050007	C.CAPACITOR CH 6.3V 1U	1	
C211	F1G0J1050007	C.CAPACITOR CH 6.3V 1U	1	
C212	F1G0J1050007	C.CAPACITOR CH 6.3V 1U	1	
C213	F1G0J1050007	C.CAPACITOR CH 6.3V 1U	1	
C214	F1G0J1050007	C.CAPACITOR CH 6.3V 1U	1	
C215	F1G0J1050007	C.CAPACITOR CH 6.3V 1U	1	
C216	F3F0J476A032	E.CAPACITOR CH 6.3V 47U	1	
IC201	MN34010PLH-V	OTHER IMAGE SENSORS	1	E.S.D.
Q201	B1HBBBE00002	TRANSISTOR	1	E.S.D.
Q202	B1HBBBE00002	TRANSISTOR	1	E.S.D.
R204	ERJ2GEJ103	M.RESISTOR CH 1/16W 10K	1	
R205	ERJ2GEJ103	M.RESISTOR CH 1/16W 10K	1	
R206	ERJ2GEJ103	M.RESISTOR CH 1/16W 10K	1	
R207	ERJ2GEJ103	M.RESISTOR CH 1/16W 10K	1	
R208	ERJ2GED273X	M.RESISTOR CH 1/16W 27K	1	
R209	ERJ2GED273X	M.RESISTOR CH 1/16W 27K	1	
R210	ERJ2GEJ681	M.RESISTOR CH 1/16W 680	1	
R211	ERJ2GEJ681	M.RESISTOR CH 1/16W 680	1	
R212	ERJ2GED273X	M.RESISTOR CH 1/16W 27K	1	
R213	ERJ2GED273X	M.RESISTOR CH 1/16W 27K	1	
R214	ERJ2GEJ681	M.RESISTOR CH 1/16W 680	1	
R215	ERJ2GEJ681	M.RESISTOR CH 1/16W 680	1	
R216	D0YAR0000007	M.RESISTOR CH 1/16W 0	1	
##	VEP79227A	HDD FPC		(RTL) E.S.D.
IC6200	C0ZBZ0001479	IC	1	E.S.D.
PP6201	K1KB40A00128	CONNECTOR 40P	1	





Ref.No.	Part No.	Part Name & Description	Pcs	Remarks	Ref.No.	Part No.	Part Name & Description	Pcs	Remarks
401	VXQ1683	MOS UNIT	1		501	K2GJYDC00004	DC CABLE	1	
401-1	VEP22399A	MOS FPC	1	(RTL) E.S.D.	502	K2KYYYY00054	AV CABLE	1	
402	VMX3706	MOS CUSHION	1		503	K1HY04YY0032	USB CABLE	1	
403	VDL2226	IR FILTER	1		504	K1HY10YY0005	COMPONENT CABLE	1	
404	VXW1004	LENS UNIT	1		△ 505	K2CA2CA00025	AC CORD	1	(P,PC,PU)
405	VXP3091	IRIS UNIT	1		△ 505	K2CT3CA00004	AC CORD	1	(20EB,GC,SG,25EB)
406	L6HA66NC0015	ZOOM MOTOR	1		△ 505	K2CQ2CA00006	AC CORD	1	(EC,EE,EF,EG,EP,GC,SG)
407	L6HA66NC0016	FOCUS MOTOR	1		△ 505	K2CP2YY00001	AC CORD	1	(GJ)
408	VXQ1684	1st LENS UNIT	1		△ 505	K2CA2CA00020	AC CORD	1	(GK)
409	VXP3093	2nd LENS MOVING FRAME UNIT	1		△ 505	K2CJ2DA00008	AC CORD	1	(GN)
410	VXQ1686	OIS UNIT	1		△ 505	K2CA2CA00027	AC CORD	1	(GT)
411	VXP3096	4th LENS FRAME MOVE UNIT	1		△ 506	N2QAE000024	REMOTE CONTROL UNIT	1	
412	VDW1749	MASTER FLANGE	1		△ 507	DE-A51BB	AC ADAPTOR	1	(P,PC)
413	VMS7969	Z GUIDE POLE (LONG)	1		△ 507	DE-A51CB	AC ADAPTOR	1	(PU,20EB,EC,EE,EF,EG,EP,GC,GJ,GN,SG,25EB)
414	VMS7969	Z GUIDE POLE (LONG)	1						
415	VMS7970	F GUIDE POLE	1		△ 507	DE-A51DA	AC ADAPTOR	1	(GK)
416	VMS7970	F GUIDE POLE	1		△ 507	DE-A51EA	AC ADAPTOR	1	(GT)
					508	VFF0442-S	CD-ROM	1	
B401	VHD2072	SCREW	1		509	VPG1V74	PACKING CASE	1	(P,PC)
B402	VHD2072	SCREW	1		509	VPG1V75	PACKING CASE	1	(PU,20EB,EC,EE,EF,EG,EP,GC,GJ,GK,GN,GT,SG)
B403	VHD2073	SCREW	1						
B404	VHD2073	SCREW	1		509	VPG1Z51	PACKING CASE	1	(25EB)
B405	VHD2073	SCREW	1		510	VPN6783	PAD	1	
B406	VHD2073	SCREW	1		511	VFC4394	TOUCH PEN UNIT	1	
B407	VHD2073	SCREW	1		512	VPF1166	PROTECTION BAG	1	
B408	VHD2073	SCREW	1		△ 513	VQT1Y00	OPERATING INSTRUCTIONS	1	(P,PC)
B409	VHD2073	SCREW	1						
B410	VHD2073	SCREW	1		△ 513	VQT1Y01	OPERATING INSTRUCTIONS	1	(PC)
B411	VHD2072	SCREW	1						
B412	VHD2072	SCREW	1						
B413	VHD2072	SCREW	1		△ 513	VQT1Y02	OPERATING INSTRUCTIONS	1	(PU)
B414	VHD2072	SCREW	1						
B415	VHD2072	SCREW	1		△ 513	VQT1Y03	OPERATING INSTRUCTIONS	1	(PU)
B416	VHD2072	SCREW	1						
					△ 513	VQT1Y19	OPERATING INSTRUCTIONS	1	(20EB)
					△ 513	VQT2A52	OPERATING INSTRUCTIONS	1	(EC)
					△ 513	VQT2A53	OPERATING INSTRUCTIONS	1	(EC)
					△ 513	VQT2A54	OPERATING INSTRUCTIONS	1	(EC)
					△ 513	VQT1Y26	OPERATING INSTRUCTIONS	1	(EE)
					△ 513	VQT1Y27	OPERATING INSTRUCTIONS	1	(EE)
					△ 513	VQT1Y07	OPERATING INSTRUCTIONS	1	(EF)
					△ 513	VQT2A49	OPERATING INSTRUCTIONS	1	(EG)
					△ 513	VQT2A50	OPERATING INSTRUCTIONS	1	(EG)
					△ 513	VQT2A51	OPERATING INSTRUCTIONS	1	(EG)
					△ 513	VQT2A55	OPERATING INSTRUCTIONS	1	(EP)
					△ 513	VQT2A56	OPERATING INSTRUCTIONS	1	(EP)
					△ 513	VQT2A57	OPERATING INSTRUCTIONS	1	(GC,GJ,SG)
					△ 513	VQT2A58	OPERATING INSTRUCTIONS	1	(GC,SG)
					△ 513	VQT2A59	OPERATING INSTRUCTIONS	1	(GC,SG)
					△ 513	VQT1Y29	OPERATING INSTRUCTIONS	1	(GK)
					△ 513	VQT1Y28	OPERATING INSTRUCTIONS	1	(GN)
					△ 513	VQT1Y04	OPERATING INSTRUCTIONS	1	(GT)
					△ 513	VQT2B44	OPERATING INSTRUCTIONS	1	(25EB)
					△ 514	VFF0476	CD-ROM(O/I)	1	(EC,EG,EP)
					△ 514	VFF0477	CD-ROM(O/I)	1	(GC,GJ,SG)

# S8. Exploded View

## S8.1. Frame and Casing Section (1)

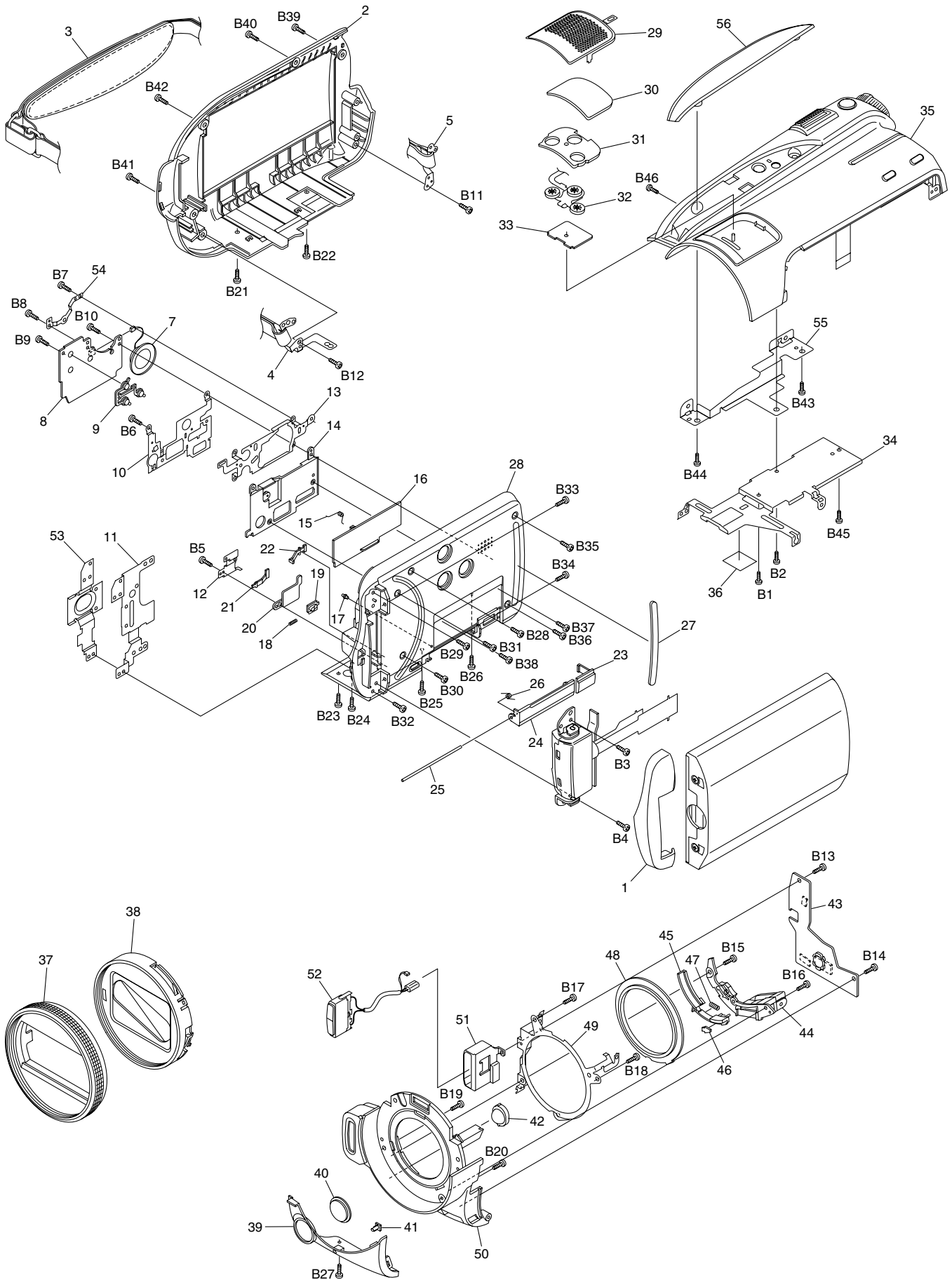

## S8.2. Frame and Casing Section (2)

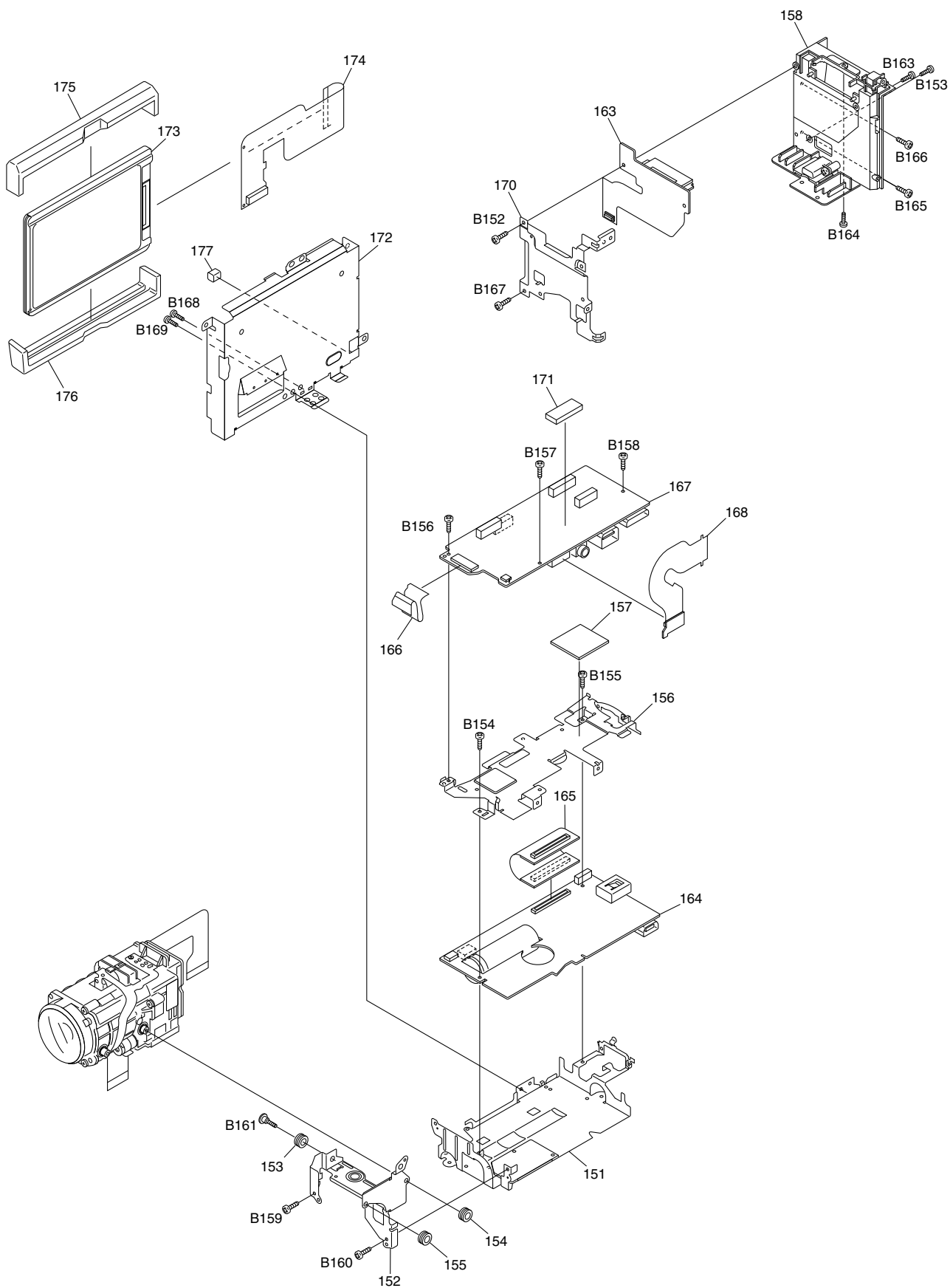

### S8.3. LCD Section

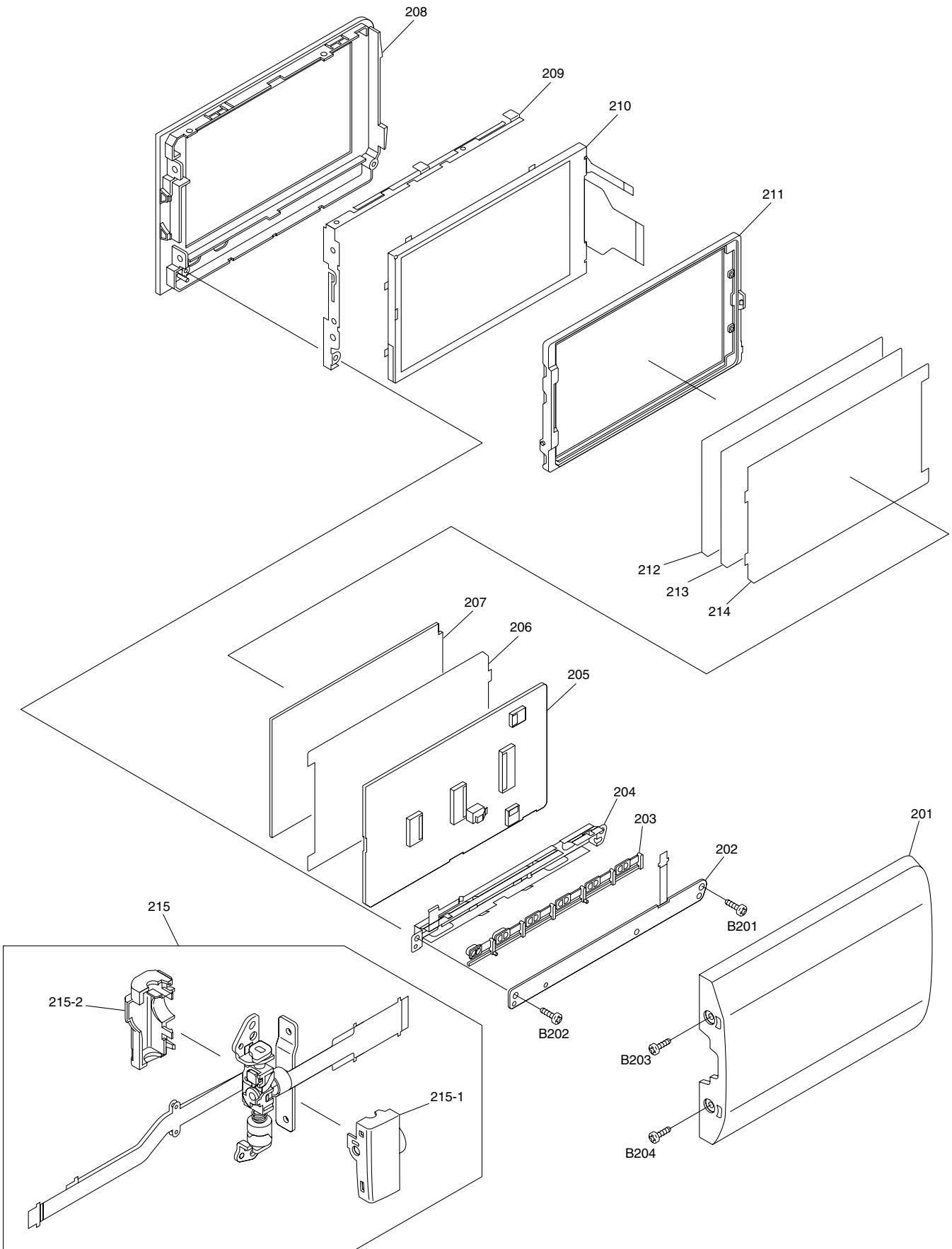

# S8.4. Camera Lens Section

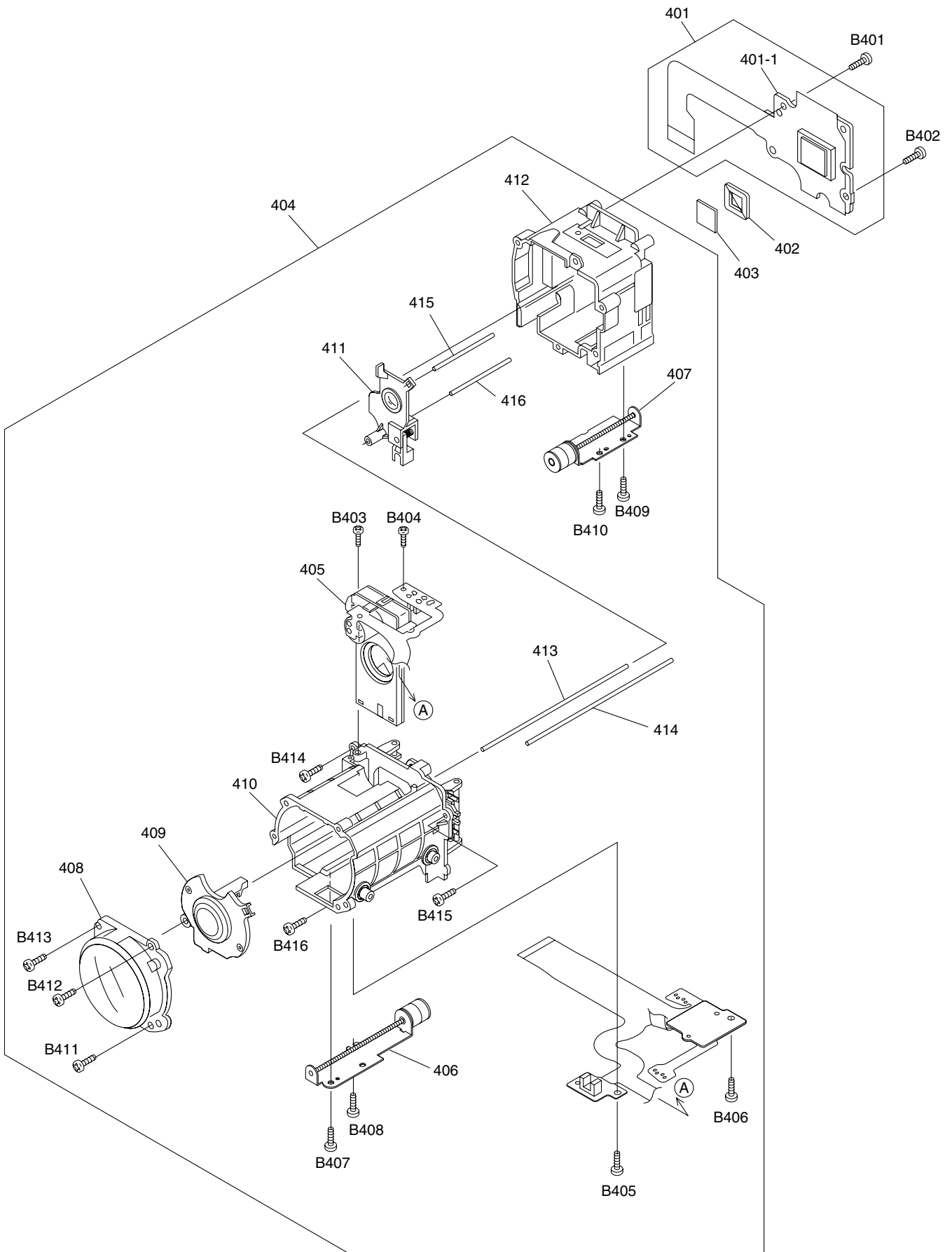



## S8.5. Packing Parts and Accessories Section

