

Service Manual

High Definition Video Camera

AVCHD™
Progressive

HDMI

SD
XC™

DOLBY
DIGITAL

Model No. **HC-V180PP**

HC-V180PU

HC-V180PR

HC-V180EB

HC-V180EC

HC-V180EF

HC-V180EG

HC-V180EP

HC-V180GA

HC-V180GC

HC-V180GK

HC-V180GN

HC-V180GW

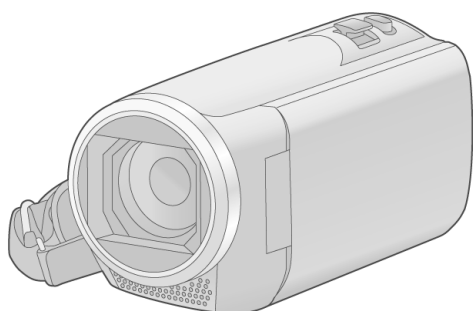

Colour
(K).....Black Type

⚠ WARNING

This service information is designed for experienced repair technicians only and is not designed for use by the general public. It does not contain warnings or cautions to advise non-technical individuals of potential dangers in attempting to service a product. Products powered by electricity should be serviced or repaired only by experienced professional technicians. Any attempt to service or repair the product or products dealt with in this service information by anyone else could result in serious injury or death.

Panasonic®

© Panasonic Corporation 2016 Unauthorized copying and distribution is a violation of law.

TABLE OF CONTENTS

	PAGE	PAGE
1 Safety Precautions	3	
1.1. General Guidelines	3	
1.2. Leakage Current Cold Check	3	
1.3. Leakage Current Hot Check (See Figure. 1).....	3	
2 Warning	4	
2.1. Prevention of Electrostatic Discharge (ESD) to Electrostatically Sensitive (ES) Devices	4	
2.2. How to Recycle the Lithium Ion Battery (U.S. Only).....	4	
2.3. How to Replace the Lithium Battery.....	5	
3 Service Navigation	6	
3.1. Introduction	6	
3.2. General Description About Lead Free Solder (PbF)	6	
3.3. How to Define the Model Suffix (NTSC or PAL model).....	7	
3.4. Formatting.....	8	
3.5. Baking of replacement IC and defective P.C.B.	9	
4 Specifications	10	
5 Location of Controls and Components	12	
6 Service Mode	14	
6.1. Model/Destination Settings	15	
6.2. Lock Search and Error History Indication	16	
6.3. Power ON Self Check Result Display.....	17	
6.4. Adjustment function for the Service	18	
6.5. Restore the backed up adjustment data.....	19	
6.6. Touch Panel Calibration	20	
7 Service Fixture & Tools	21	
7.1. Service Fixture and Tools	21	
7.2. When Replacing the Main P.C.B.	21	
7.3. Service Position	21	
8 Disassembly and Assembly Instructions	22	
8.1. Disassembly Flow Chart for the Unit	22	
8.2. PCB Location.....	23	
8.3. Disassembly Procedure for the Unit	24	
9 Measurements and Adjustments	40	
9.1. Electric Adjustment	40	
10 Factory Setting	52	
10.1. How To Turn On The Factory Settings?.....	52	
10.2. What Is The Factory Settings?	52	
11 Block Diagram	53	
11.1. Overall Block Diagram	53	
11.2. Camera/System Control Circuit Block Diagram.....	54	
11.3. Video/Audio Signal Process(1) Circuit Block Diagram.....	55	
11.4. Video/Audio Signal Process(2) Circuit Block Diagram.....	56	
11.5. Lens Drive Circuit Block Diagram.....	57	
11.6. Power Supply Circuit Block Diagram.....	58	
12 Wiring Connection Diagram	59	
12.1. Interconnection Diagram	59	
13 Schematic Diagram	60	
14 Printed Circuit Board	60	
15 Exploded View and Replacement Parts List	60	

1 Safety Precautions

1.1. General Guidelines

1. IMPORTANT SAFETY NOTICE

There are special components used in this equipment which are important for safety. These parts are marked by

 in the Schematic Diagrams, Circuit Board Layout, Exploded Views and Replacement Parts List. It is essential that these critical parts should be replaced with manufacturer's specified parts to prevent X-RADIATION, shock, fire, or other hazards. Do not modify the original design without permission of manufacturer.

2. An Isolation Transformer should always be used during the servicing of AC Adaptor whose chassis is not isolated from the AC power line. Use a transformer of adequate power rating as this protects the technician from accidents resulting in personal injury from electrical shocks. It will also protect AC Adaptor from being damaged by accidental shorting that may occur during servicing.
3. When servicing, observe the original lead dress. If a short circuit is found, replace all parts which have been overheated or damaged by the short circuit.
4. After servicing, see to it that all the protective devices such as insulation barriers, insulation papers shields are properly installed.
5. After servicing, make the following leakage current checks to prevent the customer from being exposed to shock hazards.

1.2. Leakage Current Cold Check

1. Unplug the AC cord and connect a jumper between the two prongs on the plug.
2. Measure the resistance value, with an ohmmeter, between the jumpered AC plug and each exposed metallic cabinet part on the equipment such as screwheads, connectors, control shafts, etc. When the exposed metallic part has a return path to the chassis, the reading should be between $1\text{ M}\Omega$ and $5.2\text{ M}\Omega$. When the exposed metal does not have a return path to the chassis, the reading must be infinity.

1.3. Leakage Current Hot Check (See Figure. 1)

1. Plug the AC cord directly into the AC outlet. Do not use an isolation transformer for this check.
2. Connect a $1.5\text{ k}\Omega$, 10 W resistor, in parallel with a $0.15\text{ }\mu\text{F}$ capacitor, between each exposed metallic part on the set and a good earth ground, as shown in Figure. 1.
3. Use an AC voltmeter, with $1\text{ k}\Omega/\text{V}$ or more sensitivity, to measure the potential across the resistor.
4. Check each exposed metallic part, and measure the voltage at each point.
5. Reverse the AC plug in the AC outlet and repeat each of the above measurements.
6. The potential at any point should not exceed 0.75 V RMS . A leakage current tester (Simpson Model 229 or equivalent) may be used to make the hot checks, leakage current must not exceed $1/2\text{ mA}$. In case a measurement is outside of the limits specified, there is a possibility of a shock hazard, and the equipment should be repaired and rechecked before it is returned to the customer.

Hot-Check Circuit

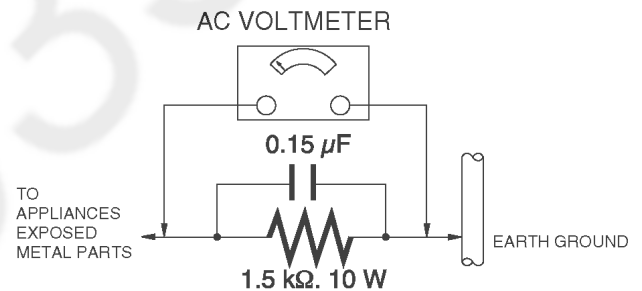

Figure. 1

2 Warning

2.1. Prevention of Electrostatic Discharge (ESD) to Electrostatically Sensitive (ES) Devices

Some semiconductor (solid state) devices can be damaged easily by static electricity. Such components commonly are called Electrostatically Sensitive (ES) Devices. Examples of typical ES devices are integrated circuits and some field-effect transistors and semiconductor "chip" components. The following techniques should be used to help reduce the incidence of component damage caused by electrostatic discharge (ESD).

1. Immediately before handling any semiconductor component or semiconductor-equipped assembly, drain off any ESD on your body by touching a known earth ground. Alternatively, obtain and wear a commercially available discharging ESD wrist strap, which should be removed for potential shock reasons prior to applying power to the unit under test.
2. After removing an electrical assembly equipped with ES devices, place the assembly on a conductive surface such as aluminum foil, to prevent electrostatic charge buildup or exposure of the assembly.
3. Use only a grounded-tip soldering iron to solder or unsolder ES devices.
4. Use only an antistatic solder removal device. Some solder removal devices not classified as "antistatic (ESD protected)" can generate electrical charge sufficient to damage ES devices.
5. Do not use freon-propelled chemicals. These can generate electrical charges sufficient to damage ES devices.
6. Do not remove a replacement ES device from its protective package until immediately before you are ready to install it. (Most replacement ES devices are packaged with leads electrically shorted together by conductive foam, aluminum foil or comparable conductive material).
7. Immediately before removing the protective material from the leads of a replacement ES device, touch the protective material to the chassis or circuit assembly into which the device will be installed.

CAUTION :

Be sure no power is applied to the chassis or circuit, and observe all other safety precautions.

8. Minimize bodily motions when handling unpackaged replacement ES devices. (Otherwise harmless motion such as the brushing together of your clothes fabric or the lifting of your foot from a carpeted floor can generate static electricity (ESD) sufficient to damage an ES device).

2.2. How to Recycle the Lithium Ion Battery (U.S. Only)

ENGLISH



A lithium ion battery that is recyclable powers the product you have purchased. Please call 1-800-8-BATTERY for information on how to recycle this battery.

FRANÇAIS



L'appareil que vous vous êtes procuré est alimenté par une batterie au lithium-ion recyclable. Pour des renseignements sur le recyclage de la batterie, veuillez composer le 1-800-8-BATTERY.

2.3. How to Replace the Lithium Battery

2.3.1. Replacement Procedure

1. Remove the MONITOR P.C.B.. (Refer to Disassembly Procedures.)
2. Unsolder the each soldering point of electric lead terminal for Lithium battery (Ref. No. "B501" at foil side of MONITOR P.C.B.) and remove the Lithium battery together with electric lead terminal. Then replace it into new one.

NOTE:

The Type No. ML-614S/DN includes electric lead terminals.

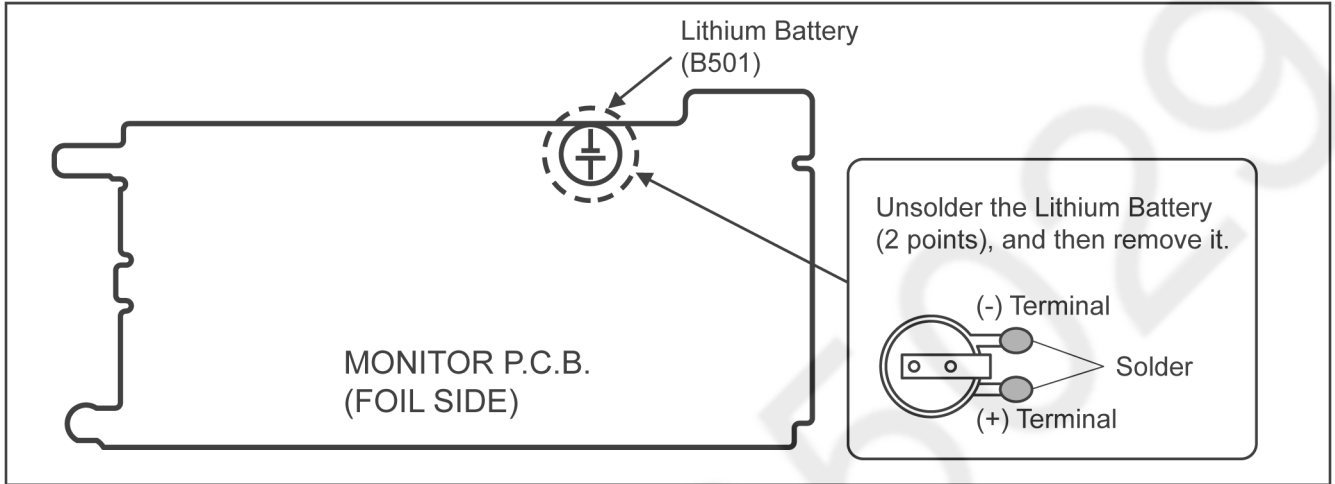

NOTE:

This Lithium battery is a critical component.

(Type No.: ML-614S/DN **Manufactured by Energy Company, Panasonic Corporation**)

It must never be subjected to excessive heat or discharge.

It must therefore only be fitted in requirement designed specifically for its use.

Replacement batteries must be of same type and manufacture.

They must be fitted in the same manner and location as the original battery, with the correct polarity contacts observed.

Do not attempt to re-charge the old battery or re-use it for any other purpose.

It should be disposed of in waste products destined for burial rather than incineration.

(For English)

CAUTION

Danger of explosion if battery is incorrectly replaced.

Replace only with the same or equivalent type recommended by the manufacturer.

Dispose of used batteries according to the manufacturer's instructions.

(For German)

ACHTUNG

Explosionsgefahr bei falschem Anbringen der Batterie. Ersetzen Sie nur mit einem äquivalentem vom Hersteller empfohlenem Typ.

Behandeln Sie gebrauchte Batterien nach den Anweisungen des Herstellers.

(For French)

MISE EN GARDE

Une batterie de remplacement inappropriée peut exploser. Ne remplacez qu'avec une batterie identique ou d'un type recommandé par le fabricant. L'élimination des batteries usées doit être faite conformément aux instructions du fabricant.

NOTE:

Above caution is applicable for a battery pack which is for HC-V180 series, as well.

3 Service Navigation

3.1. Introduction

This service manual contains technical information, which allow service personnel's to understand and service this model.

Please place orders using the parts list and not the drawing reference numbers.

If the circuit is changed or modified, the information will be followed by service manual to be controlled with original service manual.

3.2. General Description About Lead Free Solder (PbF)

The lead free solder has been used in the mounting process of all electrical components on the printed circuit boards used for this equipment in considering the globally environmental conservation.

The normal solder is the alloy of tin (Sn) and lead (Pb). On the other hand, the lead free solder is the alloy mainly consists of tin (Sn), silver (Ag) and Copper (Cu), and the melting point of the lead free solder is higher approx.30°C (86°F) more than that of the normal solder.

Distinction of P.C.B. Lead Free Solder being used

The letter of "PbF" is printed either foil side or components side on the P.C.B. using the lead free solder.(See right figure)	PbF
--	-----

Service caution for repair work using Lead Free Solder (PbF)

- The lead free solder has to be used when repairing the equipment for which the lead free solder is used.
(Definition: The letter of "PbF" is printed on the P.C.B. using the lead free solder.)
- To put lead free solder, it should be well molten and mixed with the original lead free solder.
- Remove the remaining lead free solder on the P.C.B. cleanly for soldering of the new IC.
- Since the melting point of the lead free solder is higher than that of the normal lead solder, it takes the longer time to melt the lead free solder.
- Use the soldering iron (more than 70W) equipped with the temperature control after setting the temperature at 350±30°C (662±86°F).

Recommended Lead Free Solder (Service Parts Route.)

- The following 3 types of lead free solder are available through the service parts route.
SVKZ000001-----(0.3mm 100g Reel)
SVKZ000002-----(0.6mm 100g Reel)
SVKZ000003-----(1.0mm 100g Reel)

Note

* Ingredient: tin (Sn) 96.5%, silver (Ag) 3.0%, Copper (Cu) 0.5% (Flux cored)

3.3. How to Define the Model Suffix (NTSC or PAL model)

There are six kinds of HC-V180.

- a) HC-V480M (Japan domestic model)
- b) HC-V180PP
- c) HC-V180EB/EC/EF/EG/EP
- d) HC-V180GK
- e) HC-V180GN
- f) HC-V180PU/PR/GA/GC/GW

What is the difference is that the "INITIAL SETTING" data which is stored in Flash ROM mounted on Main P.C.B..

3.3.1. Defining methods:

To define the model suffix to be serviced, refer to the rating label and caution label which are putted on the Unit.

a) HC-V480M (Japan domestic model)

The nameplate for these models show the following Safety registration mark.



b) HC-V180PP

The nameplate for this model shows the following Safety registration mark.



c) HC-V180EB/EC/EF/EG/EP

The nameplate for these models show the following Safety registration mark.



d) HC-V180GK

The nameplate for this model shows the following Safety registration mark.



e) HC-V180GN

The nameplate for this model shows the following Safety registration mark.



f) HC-V180PU/PR/GA/GC/GW

The nameplate for these models does not show any above Safety registration mark.

NOTE:

After replacing the MAIN P.C.B., be sure to achieve adjustment.

3.4. Formatting

The following formatting is for HC-V180PP.

The page number in this page does not show the page number of this service manual.

[FORMAT MEDIA]



Please be aware that if a medium is formatted, then all the data recorded on the medium will be erased and cannot be restored. Back up important data on a PC, DVD disc etc. (→ 159)

MENU : [SETUP] → [FORMAT MEDIA] → desired media

[SD CARD]/[HDD]*

* Displayed when connecting a USB HDD. (→ 100)

- Media selection screen is not displayed when the USB HDD is not connected. Touch [YES].
- When formatting is complete, touch [EXIT] to exit the message screen.
- Perform a physical formatting of the SD card when the SD card is to be disposed/ transferred. (→ 184)

- Do not turn this unit off or remove the SD card, while formatting. Do not expose the unit to vibrations or shock.

Use this unit to format media.

Do not format an SD card using any other equipment such as a PC. The card may not be used on this unit.

When disposing of or giving away the SD card, note that:

- Formatting and deletion of data on this unit or computer only changes the file management information and does not completely delete the data in the SD card.
- It is recommended that the SD card is physically destroyed or the SD card is physically formatted using this unit when disposing of or giving away the SD card.

To physically format the SD card, connect the unit via the AC adaptor, select [SETUP] → [FORMAT MEDIA] → [YES] from the menu, and then press and hold the recording start/ stop button on the screen below for about 3 seconds. When the SD card data deletion screen appears, select [YES], and then follow the on-screen instructions.

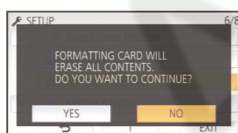

- The customer is responsible for the management of the data in the SD card.

3.5. Baking of replacement IC and defective P.C.B.

When replacing the CSP/BGA/QFN type IC mounted on the P.C.B., the problem of IC crack or foil pattern breaking in the P.C.B. might sometimes occur by rapid heating.

In order to improve the success rate of IC replacement for repair, it would be required to work out baking of replacement IC and defective P.C.B. before replacing IC.

Please refer the way of baking as follows.

Replacement IC and defective P.C.B. must be put in the heater together.

- Baking temperature and time (Hour)
80°C / 24 hour

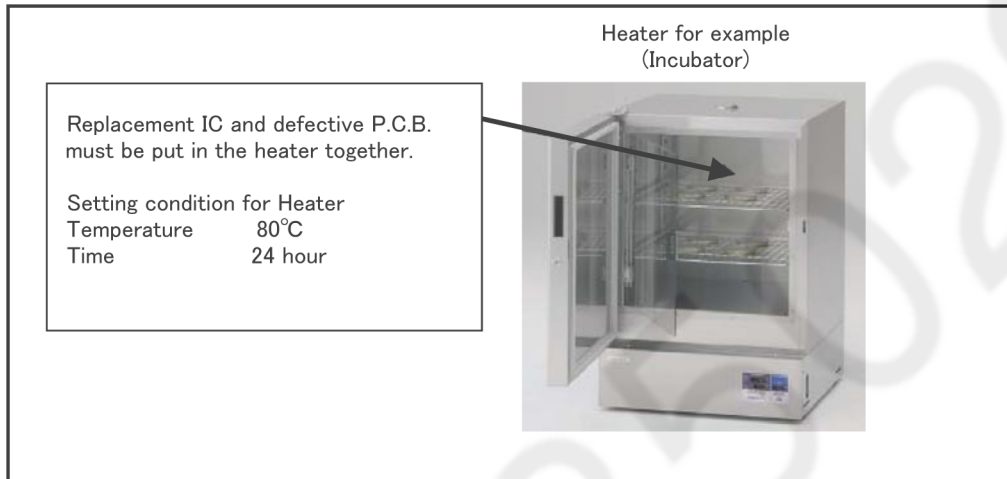

4 Specifications

The following specification is for HC-V180PP.

Some specifications may differ depending on model suffix.

The page number in this chapter does not show the page number of this service manual.

High Definition Video Camera

Information for your safety

Power source:
DC 5.0 V (When using AC adaptor)
DC 3.6 V (When using battery)

Power consumption:
Recording; 4.7 W
Charging; 7.7 W

Motion picture recording format:

[AVCHD];
AVCHD format version 2.0 compliant (AVCHD Progressive)
[MP4/iFrame];
MPEG-4 AVC file format compliant (.MP4)

Motion picture compression:

MPEG-4 AVC/H.264

Audio compression:

[AVCHD];
Dolby® Digital/2 ch
[MP4/iFrame];
AAC/2 ch

Recording mode and transfer rate:

[AVCHD]
[1080/60p];
Maximum 28 Mbps (VBR)
[PH];
Maximum 24 Mbps (VBR)
[HA];
Average 17 Mbps (VBR)
[HG];
Average 13 Mbps (VBR)
[HE];
Average 5 Mbps (VBR)

[MP4/iFrame]

[1080];
Maximum 28 Mbps (VBR)
[720];
Average 9 Mbps (VBR)
[iFrame];
Maximum 28 Mbps (VBR)
Refer to the Owner's Manual (PDF format) for the picture size and recordable time of a motion picture.

Still picture recording format:

JPEG (Design rule for Camera File system, based on Exif 2.2 standard)
Refer to the Owner's Manual (PDF format) for picture size of a still picture and number of recordable pictures.

Recording media:

SD Memory Card
SDHC Memory Card
SDXC Memory Card
Refer to the Owner's Manual (PDF format) for details on SD cards usable in this unit.

Image sensor:

1/5.8" 1MOS image sensor
Total; 2510 K
Effective pixels;
Motion picture; 2200 K (16:9)*
Still picture;
2200 K (16:9), 1700 K (4:3), 1670 K (3:2)

Lens:

Auto Iris, 50× optical zoom, F1.8 to F4.2
Focal length;
2.06 mm to 103 mm
Macro (Full range AF)
35 mm equivalent;
Motion picture;
28.0 mm to 1740 mm (16:9)*
Still picture;
28.0 mm to 1740 mm (16:9),
34.0 mm to 1766 mm (4:3),
33.6 mm to 1714 mm (3:2)

Minimum focus distance;
Normal; Approx. 2.0 cm (0.8") (Wide)/
Approx. 2.2 m (7.2 feet) (Tele)
Tele Macro; Approx. 1.1 m (3.6 feet) (Tele)
Intelligent Auto Macro;
Approx. 1.0 cm (0.4") (Wide)/
Approx. 1.1 m (3.6 feet) (Tele)

Zoom:
i.Zoom OFF 62×*, 90× i.Zoom, 150×/500×
digital zoom
(Using image sensor effective area)

* When [O.I.S.] is set to [Standard] and Level
Shot Function is set to off.

Image stabilizer function:
Optical (Hybrid Optical Image Stabilizer, Active
Mode (Rotation correction), Optical Image
Stabilizer Lock function)

Level Shot Function:
Off/Normal/Strong

Creative Control:
[Miniature Effect]/[Silent movie]/[8mm movie]/
[Time Lapse Rec]

Monitor:
2.7" wide LCD monitor (Approx. 230 K dots)

Microphone:
Stereo (with a Zoom Microphone)

Minimum required illumination:
Approx. 4 lx (1/30 with Low Light Mode in the
Scene Mode)

Approx. 1 lx with the Night Mode function

AV connector video output level:
1.0 Vp-p, 75 Ω, NTSC system

HDMI mini connector video output level:
HDMI™ (x.v.Color™) 1080p/1080i/480p

AV connector audio output level (Line):
251 mV, 600 Ω, 2 ch

HDMI mini connector audio output level:
[AVCHD]; Dolby Digital/Linear PCM
[iFrame], [MP4]; Linear PCM

USB:
Reader function
SD card; Read only (No copyright protection
support)

Hi-Speed USB (USB 2.0), USB terminal Type
micro AB

USB host function (for USB HDD)

Battery charging function (Charges from USB
terminal when the main unit is off)

Dimensions:
53 mm (W)×59 mm (H)×116 mm (D)
[2.087" (W)×2.323" (H)×4.567" (D)]
(including projecting parts)

Mass (Weight):
Approx. 211 g (Approx. 0.465 lbs.)
[without battery (supplied) and an SD card (optional)]

Mass (Weight) in operation:
Approx. 256 g (Approx. 0.564 lbs.)
[with battery (supplied) and an SD card (optional)]

Operating temperature:
0 °C to 40 °C (32 °F to 104 °F)

Operating humidity:
10%RH to 80%RH

Battery operation time:
See page 13

AC adaptor
Information for your safety

Power source:
AC 110 V to 240 V, 50/60 Hz
AC input:
0.25 A
DC output:
DC 5.0 V, 1.8 A

Dimensions:
66.4 mm (W)×58.5 mm (H)×31 mm (D)
[2.62" (W)×2.30" (H)×1.22" (D)]

Mass (Weight):
Approx. 60 g (Approx. 0.132 lbs.)

5 Location of Controls and Components

The following description is for HC-V180PP.

Some descriptions may differ depending on model suffix.

The page number in this chapter does not show the page number of this service manual.

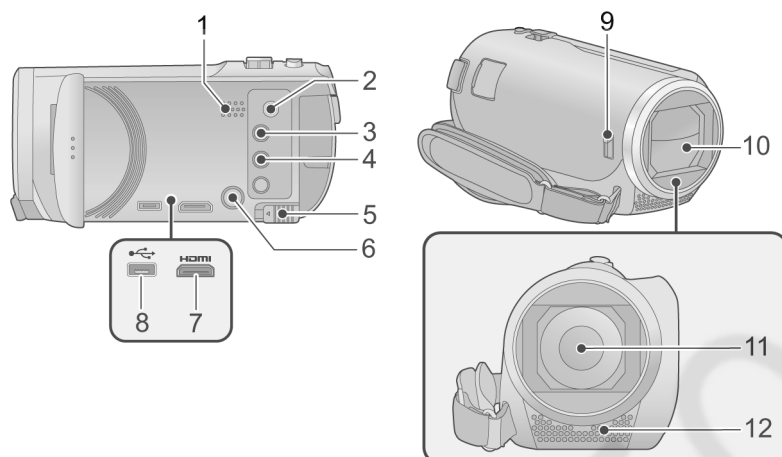

- 1 **Speaker**
- 2 **A/V connector [A/V]** (→ 94, 107)
- 3 **Recording/playback button** [] (→ 15)
- 4 **Level Shot Function button** [] (→ 38)
- 5 **Battery release lever [BATT]** (→ 9)
- 6 **Power button** [ / ] (→ 14)
- 7 **HDMI mini connector [HDMI]** (→ 94)
- 8 **USB terminal** [] (→ 99, 105, 118)

- 9 **Lens cover opening/closing switch**
When not using the unit, close the lens cover to protect the lens.
 - Slide the opening/closing switch to open/close the cover.

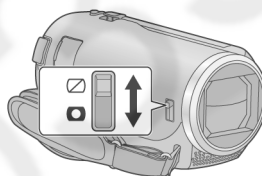

- 10 **Lens cover**
- 11 **Lens**
- 12 **Internal stereo microphones**

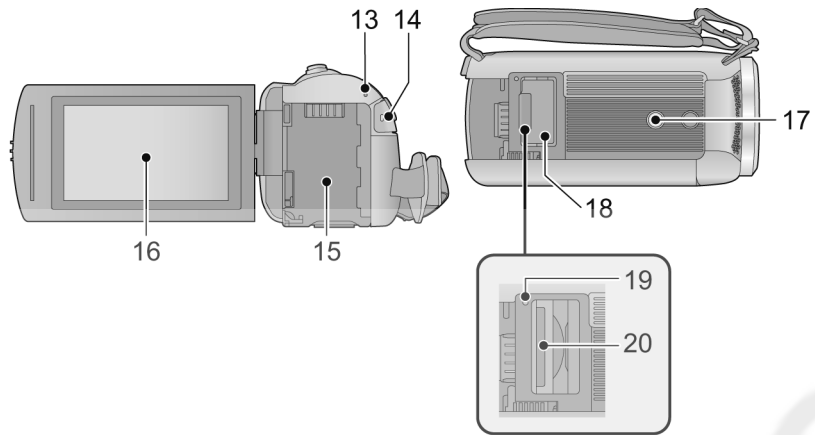

- 13 Status indicator (→ 14)
- 14 Recording start/stop button (→ 20)
- 15 Battery holder (→ 9)
- 16 LCD monitor (Touch screen) (→ 16)

- 17 Tripod receptacle
 - Attaching a tripod with a screw length of 5.5 mm (0.22 ") or more may damage the unit.
- 18 SD card cover (→ 13)
- 19 Access lamp [ACCESS] (→ 13)
- 20 Card slot (→ 13)

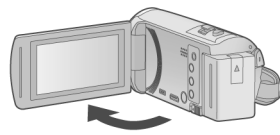

- It can open up to 90°.

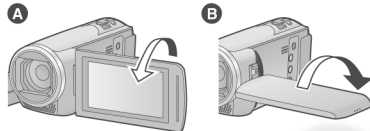

- It can rotate up to 180° **A** towards the lens or 90° **B** towards the opposite direction.

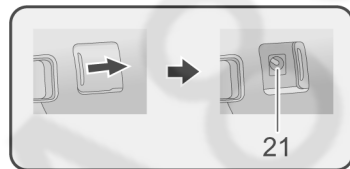

- 21 DC input terminal [DC IN] (→ 10)
 - Do not use any other AC adaptors except the supplied one.

- 22 Photoshot button [] (→ 21)
- 23 Zoom lever [W/T] (In Motion Picture Recording Mode or Still Picture Recording Mode) (→ 37)/ Thumbnail display switch [/] (→ 25)/ Volume lever [-VOL+] (In Playback Mode) (→ 26)

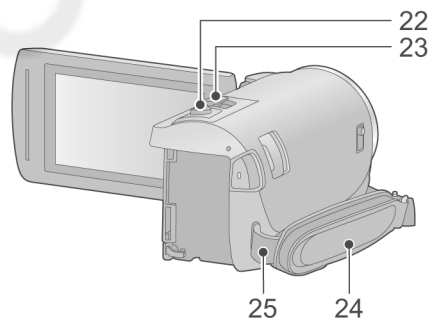

- 24 Grip belt
 - Adjust the length of the grip belt so that it fits your hand.

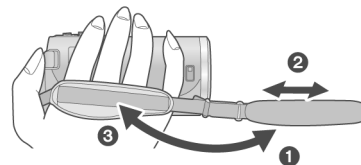

- 1 Flip the belt.
- 2 Adjust the length.
- 3 Replace the belt.
- 25 Shoulder strap fixture

6 Service Mode

Indication method of the service menu

1. Keep pressing the "Power" button, "Zoom lever" to W side and "Recording/Playback" button for more than 3 seconds until the top screen of the Service Mode Menu being displayed.

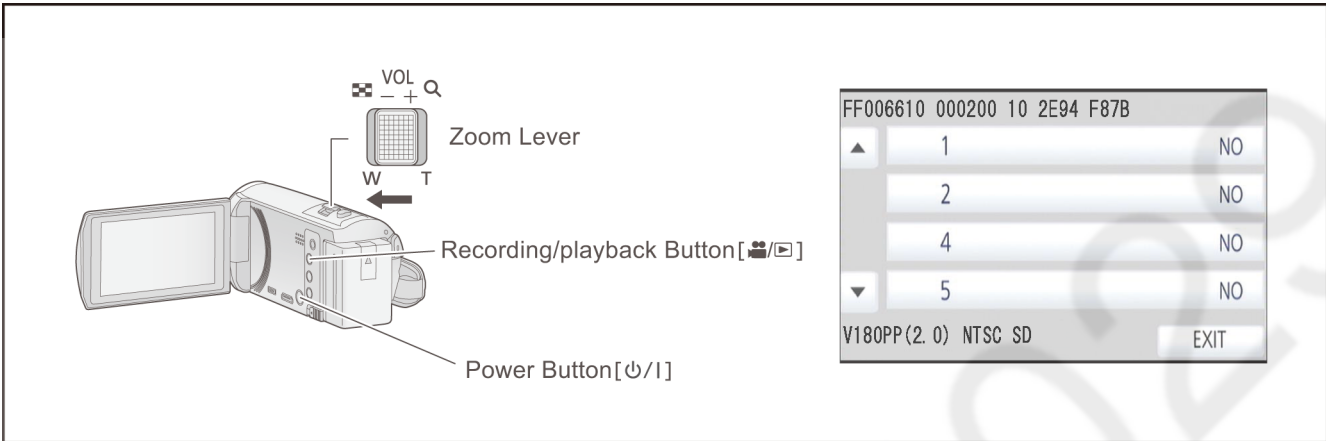

Service mode menu

Screen display	Contents	Function
1	Factory settings	Function to throw a product up in a factory shipment state.
2	Model/Destination settings	Change the Model/Destination. (Selectable models and destinations are displayed.)
4	Lock search history indication	Display the camera system error cord for three histories saved in EEPROM.
5	Power ON self check result display	Power ON self check (function to diagnose correct function of the device and interface between devices) result display.
14	Adjutment function for the service	The service adjustment do setup and adjustment of the following items required in the field service.
15	Restore the backed up adjustment data	Restore the adjustment data to new or repaired Main P.C.B. from SD card that the data backed up from original Main P.C.B. before repairs or replacement.
16	Touch panel calibration	Calibrate the touch positions of the touch panel.

NOTE:

Do not using service mode except above table of Service mode menu.

2. End method of the top screen of the service mode menu
Touch the [EXIT] of LCD to end the service mode, and then POWER OFF.

6.1. Model/Destination Settings

Touch the [2] of LCD, select model/destination settings.

Operation specifications

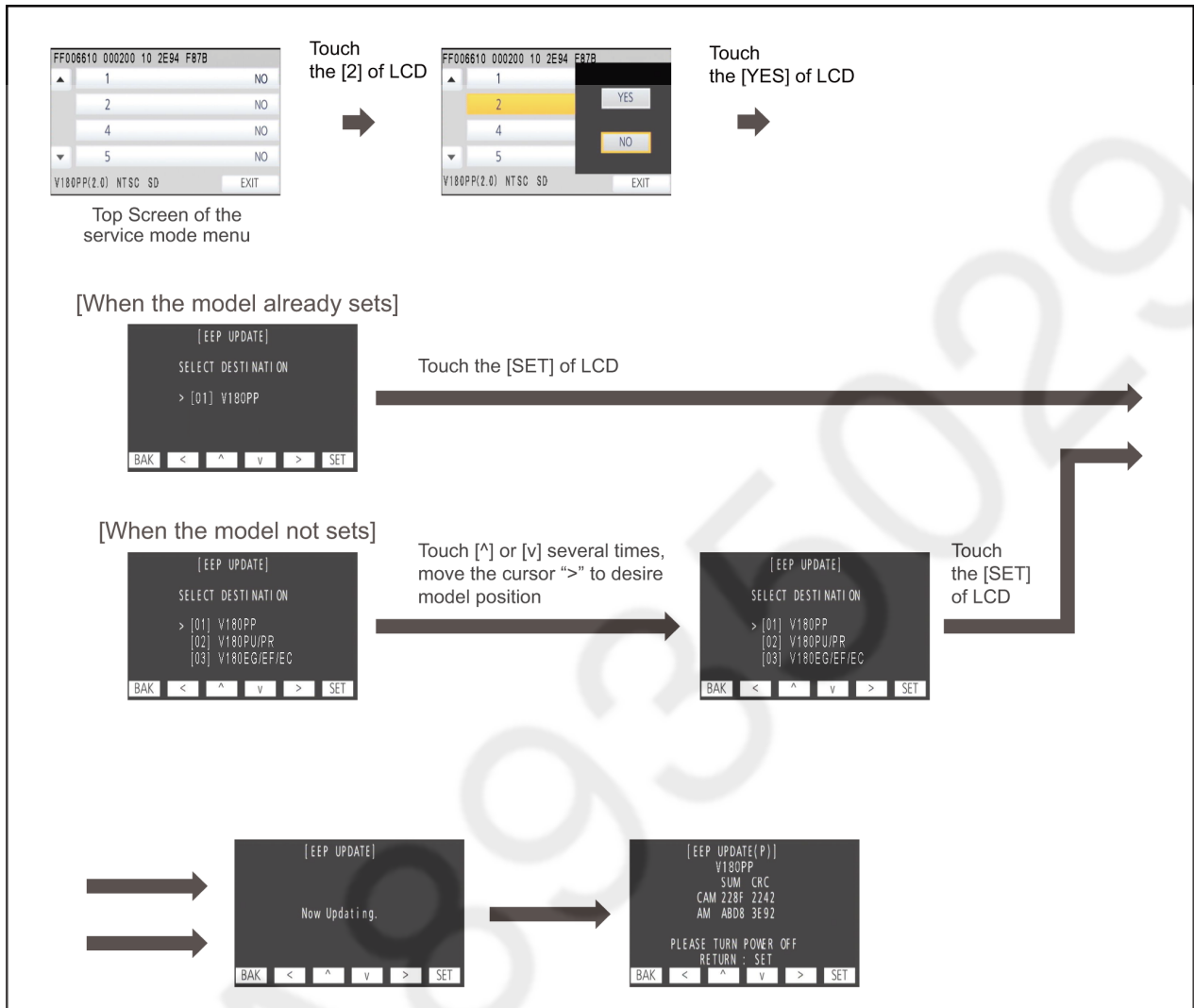

Function description

- Change the Model/Destination

Display the lists of model/distination which the unit can be changed, if a shipment setup is finished. Therefore in some cases, the model/destination that is currently set is only displayed.

End method of operation

- Touch the [SET] of LCD to exit the mode/destination settings, and then POWER OFF.

6.2. Lock Search and Error History Indication

Touch the [4] of LCD, select Lock search and error history indication.

Operation specifications

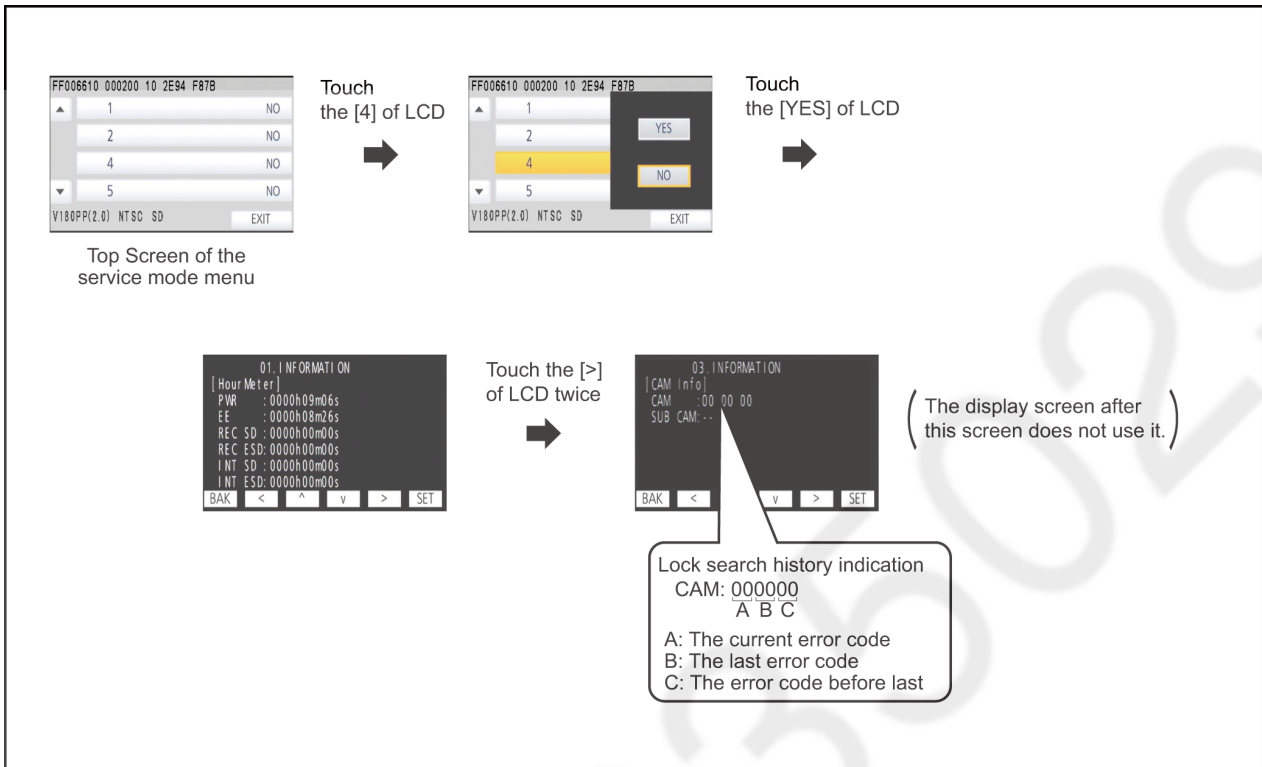

Indication contents

- Lock search history indication
 Display the camera system error cord for three histories saved in EEPROM.
- The error cord contents which are displayed

Error code	Description	Problematic Parts
51	Focus control is abnormal	FOCUS STEPPING MOTOR / LENS UNIT
52	Zoom control is abnormal	2ND STEPPING MOTOR / LENS UNIT
53	OIS lens control is abnormal	LENS UNIT
54	Zoom control is abnormal (2)	3RD STEPPING MOTOR / LENS UNIT

End method of operation

- Touch the [BAK] of LCD to exit the lock search and error history indication, and then POWER OFF.

6.3. Power ON Self Check Result Display

Touch the [5] of LCD, select Power ON self check result display.

Operation specifications

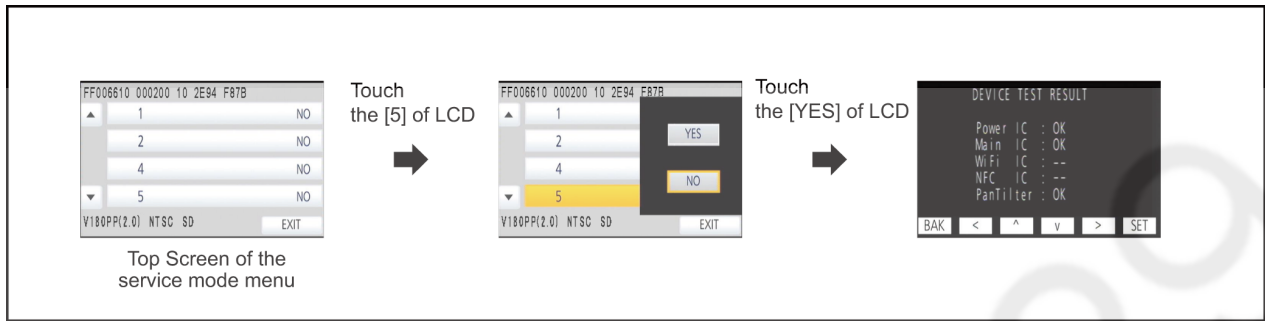

Indication contents

- Power ON self check result display

Function to diagnose correct function of the device and interface between devices result display.

Display the following communication test result.

- Power IC : Communication test between IC3401 and IC1503
- Main IC : DDR. Communication test between IC3401 and IC3402/IC3403
- WiFi IC : (Excluded)
- NFC IC : (Excluded)

Display other than “OK” are abnormalities of each lines.

- PanTilter : Error display of the Remote Pan Tilt Cradle (VW-CTR1)
(When not connected the remote pan tilt cradle, display “--”.)
When error is occurred, display “NG” with the error code.

Error Code	Description
NG 01	Battery undercut
NG 04	The start-up state of the update error factor
NG 10	The failure of Tilt motor
NG 80	USB Communication Error

End method of operation

- Touch the [BAK] of LCD to exit the power on self check result display, and the POWER OFF.

6.4. Adjustment function for the Service

Touch the [14] of LCD, select the adjustment function for the service.

Operation Specifications (until before the start of the adjustment)

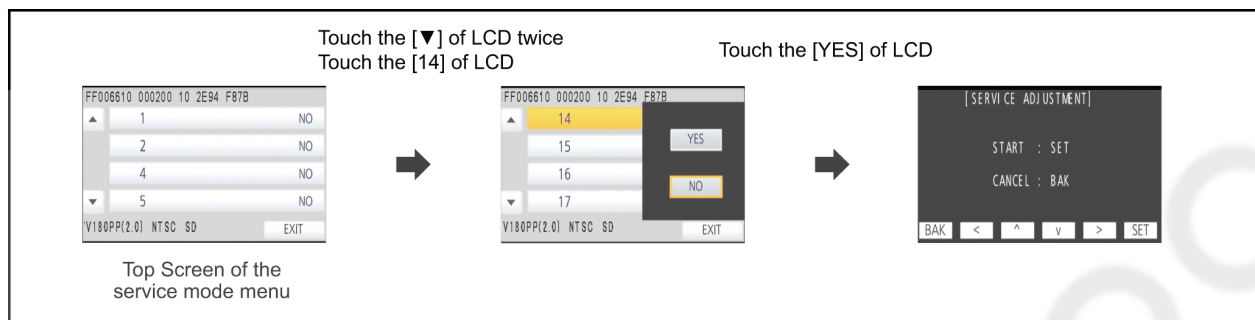

Function description

The service adjustment do setup and adjustment of the following items required in the field service.

For a detailed content, such as the adjustment procedure, refer to “9 Measurements and Adjustments”.

- Model setting
- Setting of the file name for adjustment data backup to SD card.
- Execution of adjustment data backup to SD card
- Checking of Switches
- Camera adjustment
- Zoom Tracking adjustments
- Indoor White Balance Adjustment
- Outdoor White Balance Adjustment

End method of operation

- Press the power button to turn the unit off.

6.5. Restore the backed up adjustment data

Touch the [15] of LCD, select restoring the backed up adjustment data from SD card to the unit.

Operation Specifications

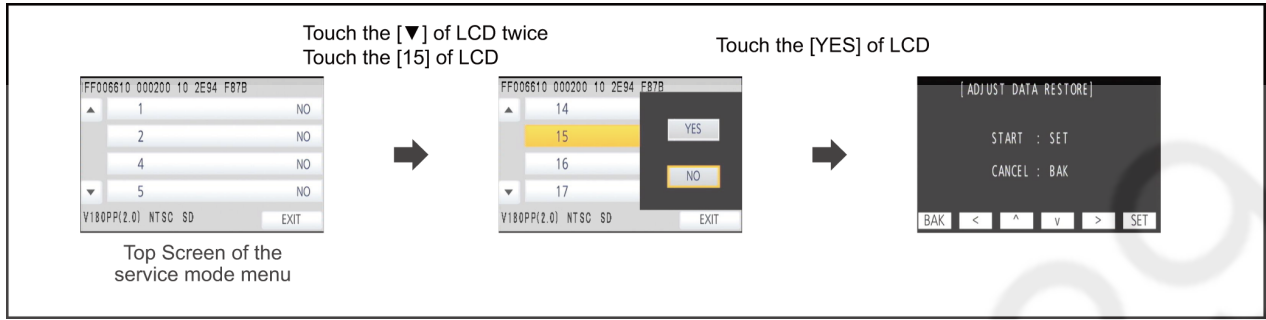

Function description

Restore the adjustment data to new or repaired Main P.C.B. from SD card that the data backed up from original Main P.C.B. before repairs or replacement.

To backup the adjustment data, use “6.4. Adjustment function for the Service”.

Restoring procedure

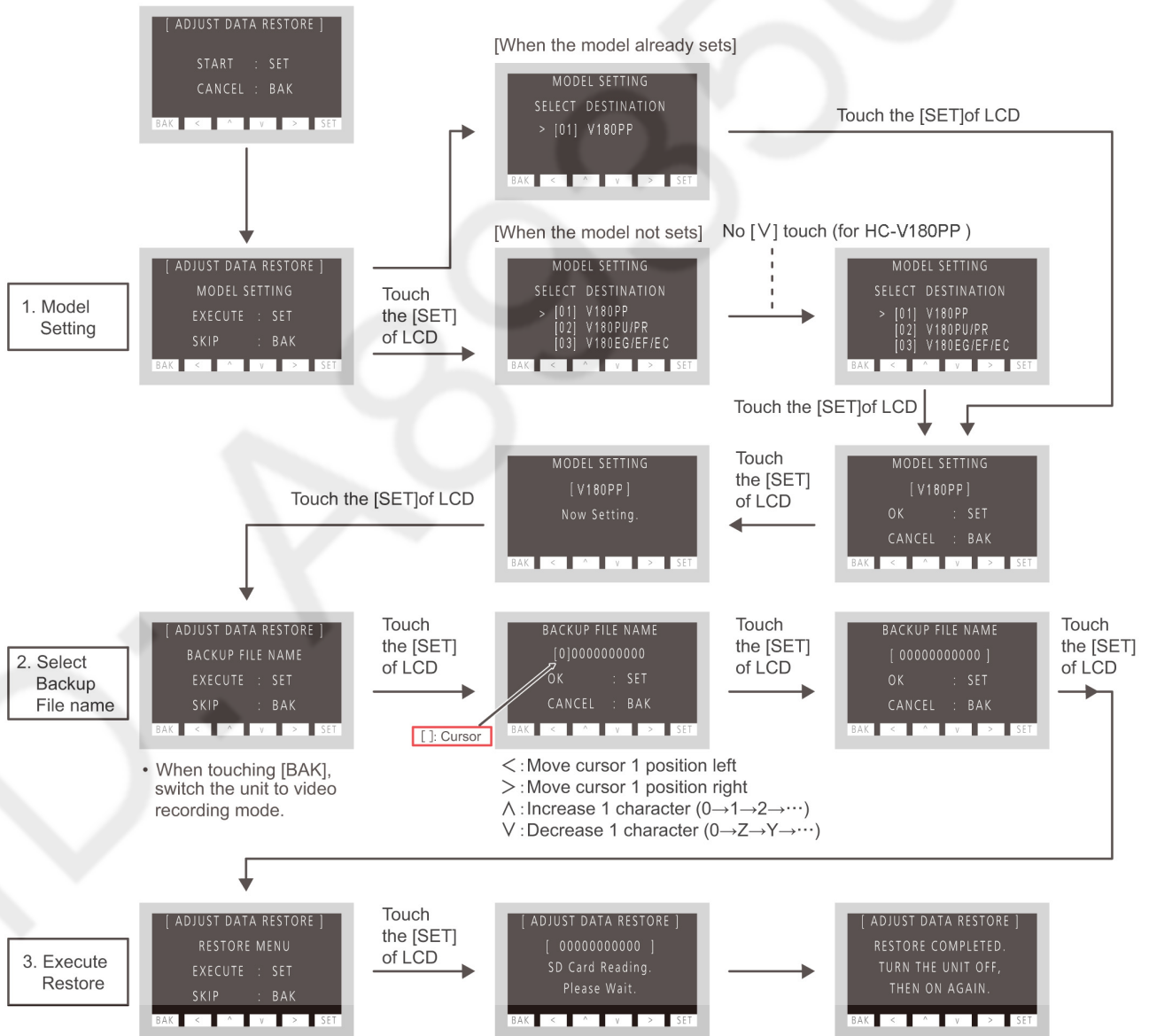

End method of operation

- Press the power button to turn the unit off.

6.6. Touch Panel Calibration

Touch the [16] of LCD, select the calibration of touch panel.

Operation Specifications

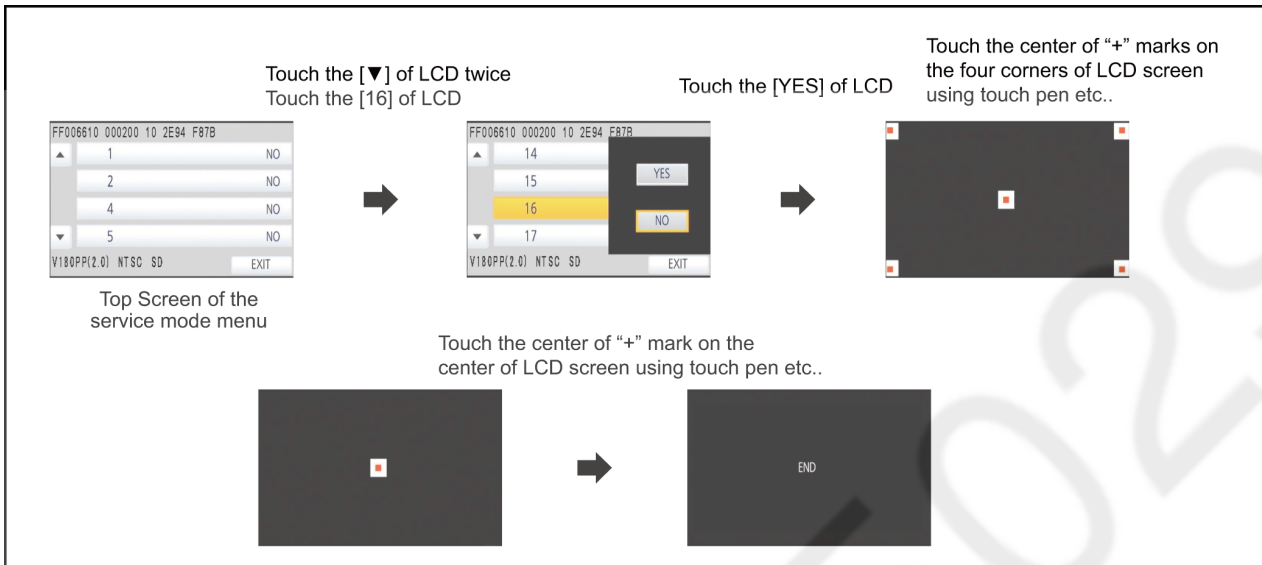

Function description

Calibrate the touch positions of the touch panel.

End method of operation

- Press the power button to turn the unit off.

7 Service Fixture & Tools

7.1. Service Fixture and Tools

The following Service Fixture and tools are used for checking and servicing this unit.

Parts name	Parts No.	Remarks
Zoom Guide Shaft	VMS8231	2 use

(* When Installing the MOS Unit)

7.2. When Replacing the Main P.C.B.

After replacing the MAIN P.C.B., be sure to achieve adjustment.

7.3. Service Position

This Service Position is used for checking and replacing parts. Use the following Extension cables for servicing.

No.	Parts No.	Connection	Form
1	RFKZ0354	FP6001(MAIN) - MONITOR FPC	37PIN 0.3 FFC
2	RFKZ0444	PP6001(MAIN) - PS6401(SD HOLDER)	50PIN 0.5 B to B
3	VFK1480	FP6003(MAIN) - ECM FPC	6PIN 0.5 FFC
4	VFK1440	FP6402(SD HOLDER) - TOP OPERATION	10PIN 0.5 FFC

7.3.1. Extension Cable Connection

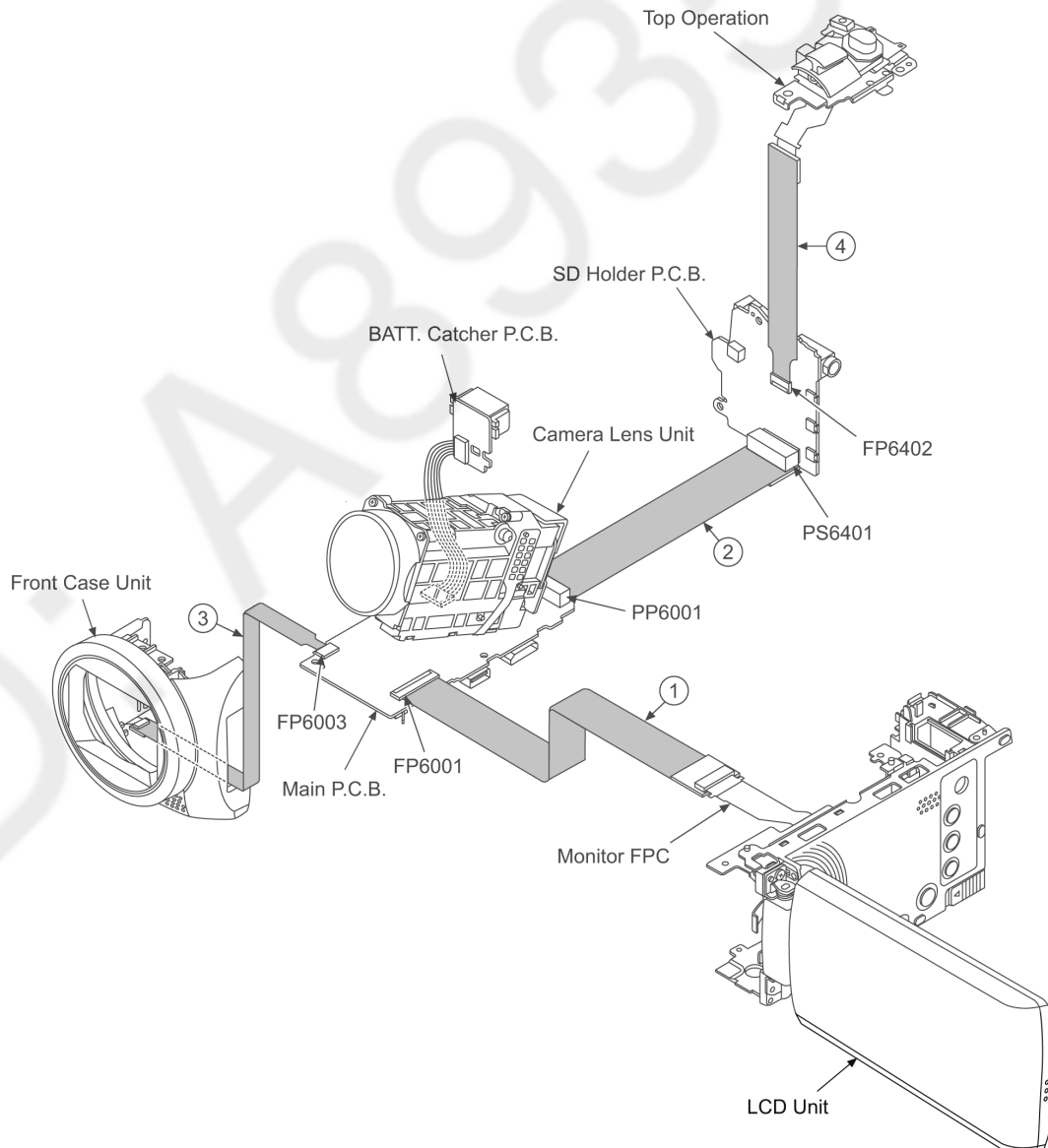

8 Disassembly and Assembly Instructions

8.1. Disassembly Flow Chart for the Unit

This is a disassembling chart.

When assembling, perform this chart conversely.

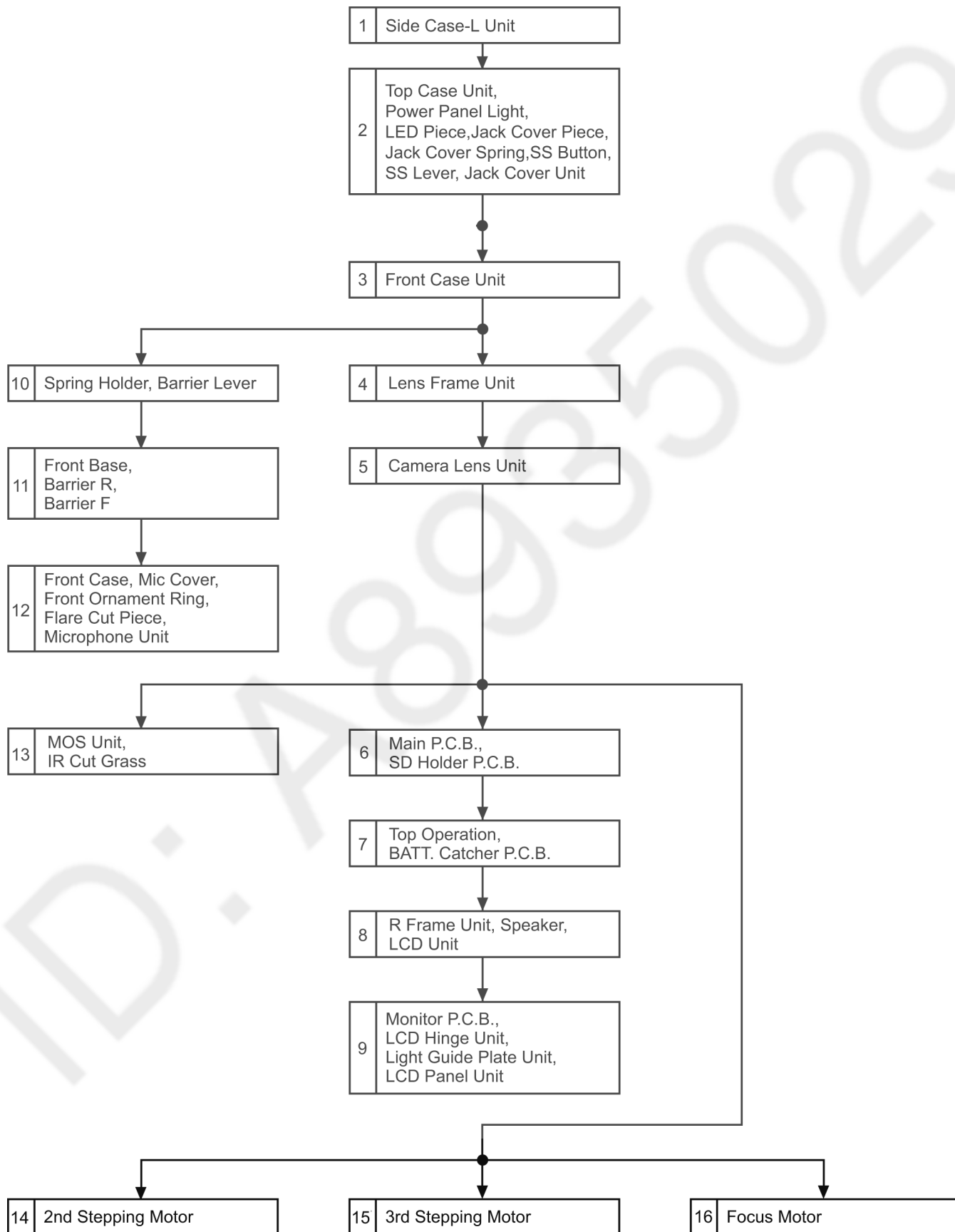

8.2. PCB Location

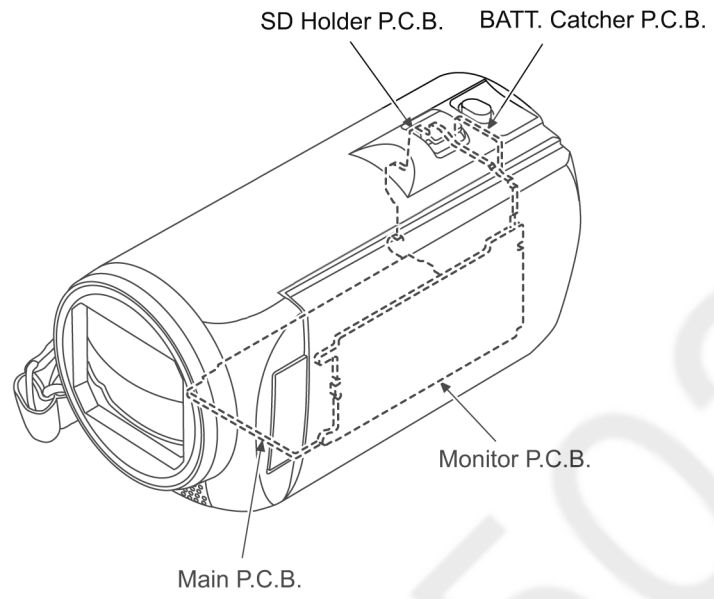

8.3. Disassembly Procedure for the Unit

No.	Item	Fig	Removal
1	Side Case-L Unit	(Fig. D1) (Fig. D2)	Screw (A) x 3
			Screw (B) x 1
			Locking tab x 3
			Hooking part x 3
			Side Case-L Unit
2	Top Case Unit, Power Panel Light, LED Piece, Jack Cover Piece, Jack Cover Spring, SS Button, SS Lever, Jack Cover Unit	(Fig. D3)	Screw (C) x 1
			Locking tab x 3
			Top Case Unit
			Power Panel Light
			LED Piece
			Screw (D) x 1
			Convex x 1
			Hooking part x 1
			Jack Cover Piece
			Jack Cover Spring
			SS Button
			SS Lever
			Jack Cover Unit
3	Front Case Unit	(Fig. D4)	Screw (E) x 1
			Screw (F) x 2
			FP6003 (Flex)
			Screw (G) x 1
			Convex x 2
			Front Case Unit
4	Lens Frame Unit	(Fig. D8) (Fig. D9)	Screw (J) x 1
			Screw (K) x 1
			P6003 (Connector)
			Screw (L) x 1
			Convex x 2
			Locking tab x 2
5	Camera Lens Unit	(Fig. D10)	FP301 (Flex)
			FP6008 (Flex)
			Convex x 2
			Camera Lens Unit
6	Main P.C.B., SD Holder P.C.B.	(Fig. D11) (Fig. D12)	Screw (M) x 1
			Screw (N) x 3
			Screw (O) x 1
			Convex x 2
			Hooking part x 1
			Heat Radiation Plate Unit
			P6401 (Connector)
			FP6001 (Flex)
			FP6402 (Flex)
			Convex x 5
			Locking tab x 4
Bottom Frame Unit			
Main P.C.B.			
SD Holder P.C.B.			
7	Top Operation, BATT. Catcher P.C.B.	(Fig. D13)	Convex x 1
			Hooking part x 1
			Locking tab x 1
			Top Operation
			BATT. Catcher P.C.B.

No.	Item	Fig	Removal	
8	R Frame Unit, Speaker, LCD Unit	(Fig. D14)	Screw (P) x 2	
			Locking tab x 4	
			R Frame Unit	
			Convex x 1	
			LCD Lever	
		(Fig. D15)	Convex x 2	
			Convex x 6	
			Speaker	
			Convex x 2	
			LCD Unit	
9	Monitor P.C.B., LCD Hinge Unit, Light Guide Plate Unit, LCD Panel Unit	(Fig. D16)	Screw (Q) x 2	
			Locking tab x 9	
			LCD Case (T) Unit	
			Screw (R) x 1	
			FP901 (Flex)	
			FP904 (Flex)	
			FP905 (Flex)	
			(Fig. D17)	Locking tab x 1
				Hooking part x 1
		Monitor P.C.B.		
		LCD Hinge Unit		
		LCD Frame A		
		Locking tab x 4		
		Light Guide Plate Unit		
		LCD Panel Unit		
		(Fig. D18)		Reflection Sheet
			Light Guide Plate	
			Diffusion Sheet	
Prism Sheet (B)				
Prism Sheet (A)				
LGP Holder				
10	Spring Holder, Barrier Lever		(Fig. D19)	Screw (S) x 1
				Spring Holder
				Barrier Spring
		Locking tab x 2		
		Barrier Lever		
		Barrier Lever		
11	Front Base, Barrier R, Barrier F	(Fig. D20)	Projection part x 3	
			Lens Damper Rubber	
			Screw (T) x 4	
			Convex x 3	
			Front Base	
			Barrier R	
12	Front Case, Mic Cover, Front Ornament Ring, Flare Cut Piece, Microphone Unit	(Fig. D21)	Screw (U) x 2	
			Locking tab x 1	
			Front Case	
			Mic Cover	
			Front Ornament Ring	
			Flare Cut Piece	
			Mic Sponge-F	
			Mic Sponge-M	
			Microphone Unit	
			Mic Sponge-R	
			13	MOS Unit, IR Cut Grass
MOS Unit				
MOS Cushion				
IR Cut Grass				
(Fig. D23) (Fig. D24)	NOTE: (When Installing the MOS Unit)			
14	2nd Stepping Motor	(Fig. D25)	Solder x 16 points	
			Screw (W) x 3	
			Convex x 5	
		(Fig. D26)	Screw (X) x 2	
			2nd Stepping Motor	

No.	Item	Fig	Removal
15	3rd Stepping Motor	(Fig. D27)	Solder x 4 points
			Screw (Y) x 1
			Convex x 1
		(Fig. D28)	Screw (Z) x 2
			3rd Stepping Motor
16	Focus Motor	(Fig. D29)	Solder x 8 points
			Screw (a) x 1
			Convex x 1
		(Fig. D30)	Screw (b) x 2
			Focus Motor

NOTE:

When servicing and reassembling, remove the Card and battery pack from the unit.

- Card
- Battery Pack

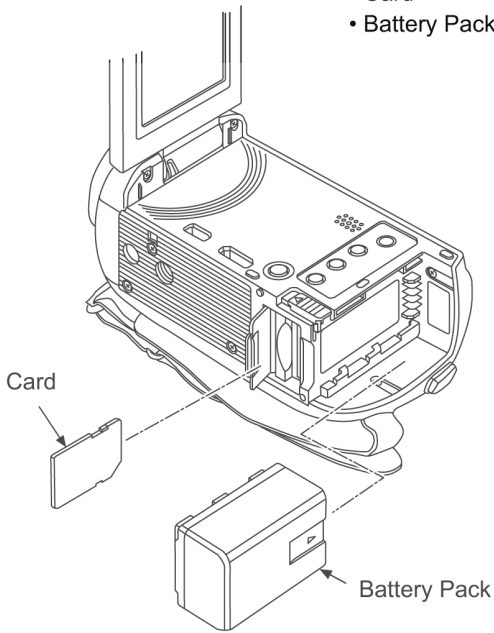

8.3.1. Removal of the Side Case-L Unit

- Screw (A) × 3

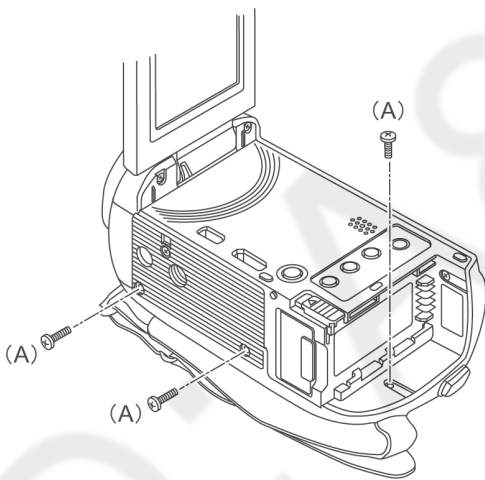

Screw (A)

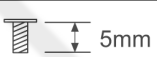

BLACK

(Fig. D1)

- Screw (B) × 1
- Locking tab × 3
- Hooking part × 3

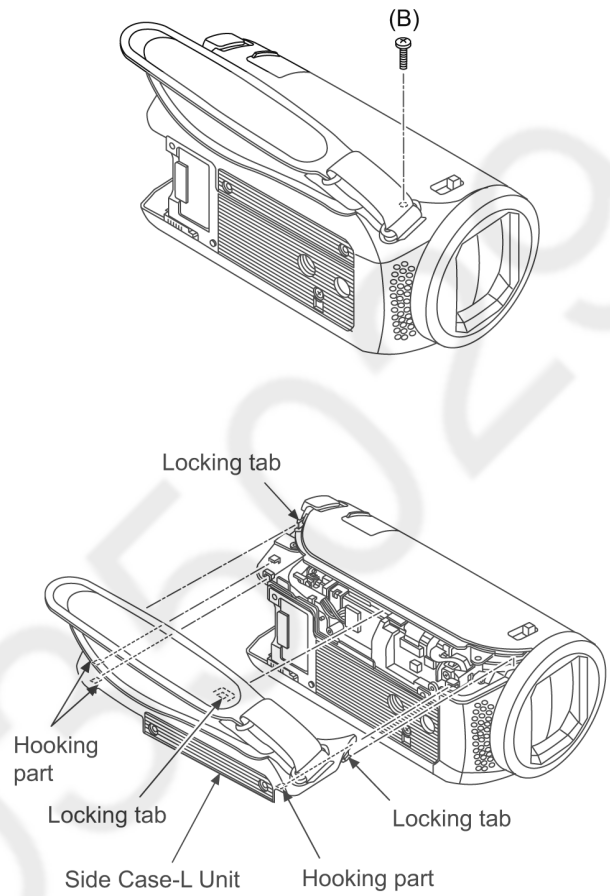

NOTE: (When Installing)

- Install the locking tab and hooking part of the side case-L unit in following order:
(1) → (2) → (3) → (4) → (5)

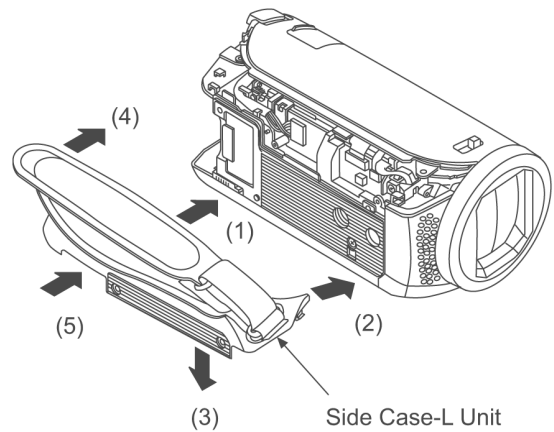

Screw (B)



BLACK

(Fig. D2)

8.3.2. Removal of the Top Case Unit, Power Panel Light, LED Piece, Jack Cover Piece, Jack Cover Spring, SS Button, SS Lever, Jack Cover Unit

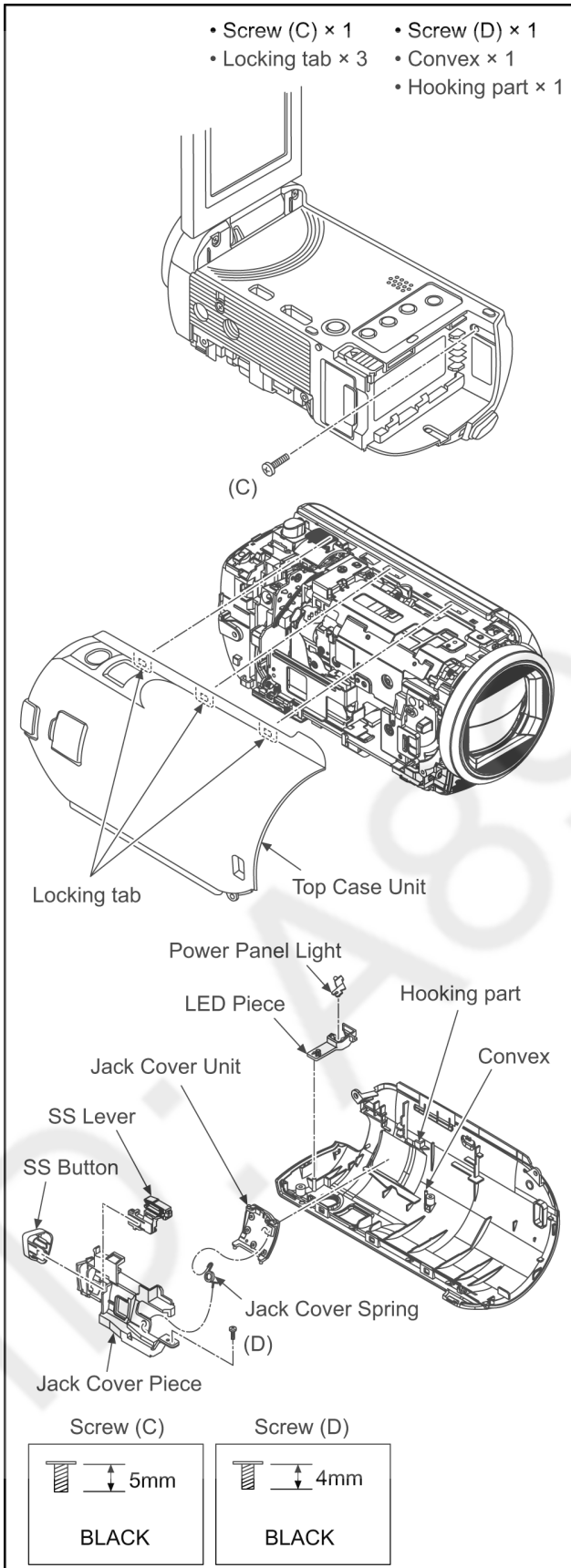

(Fig. D3)

8.3.3. Removal of the Front Case Unit

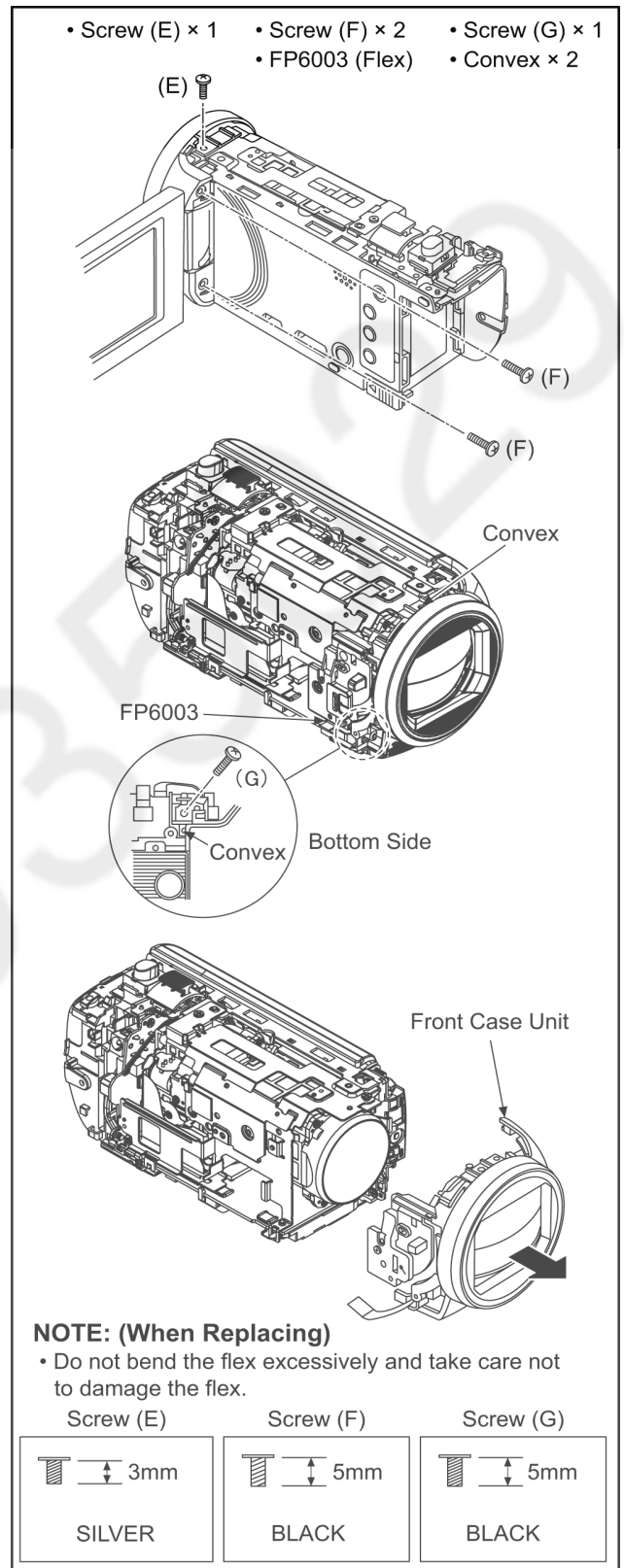

(Fig. D4)

8.3.4. Removal of the Lens Frame Unit

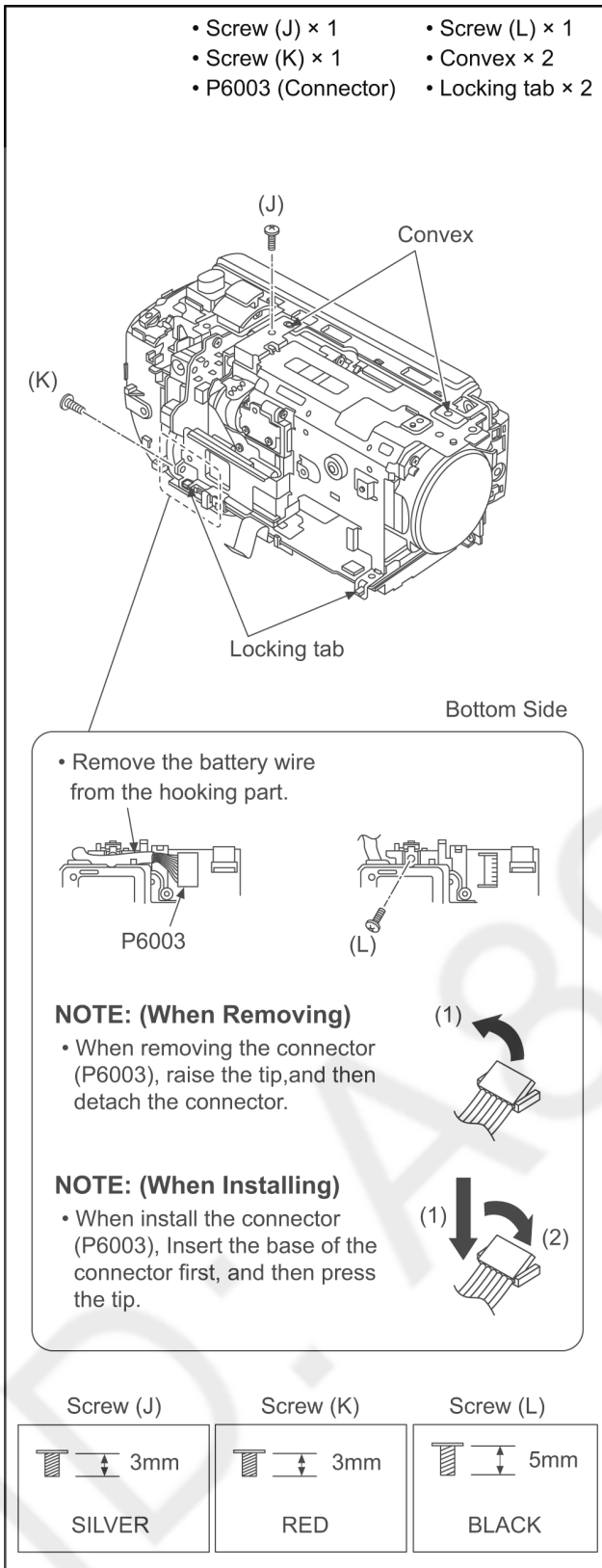

(Fig. D8)

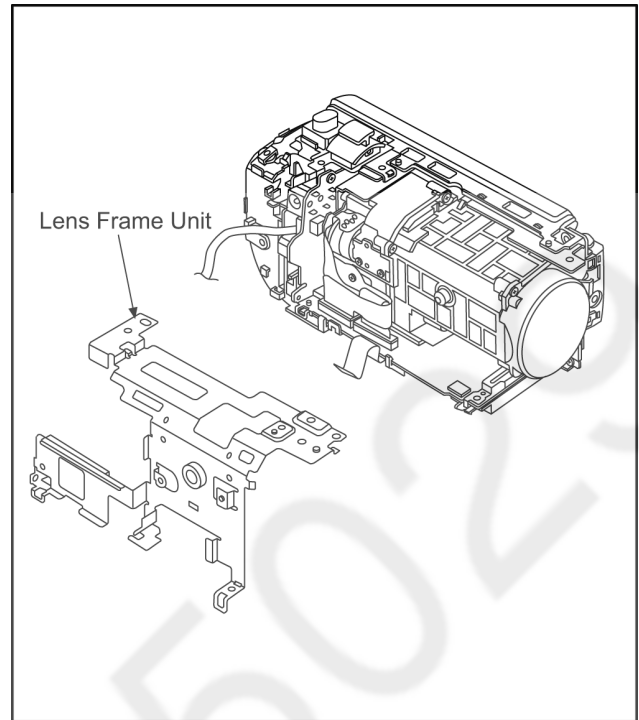

(Fig. D9)

8.3.5. Removal of the Camera Lens Unit

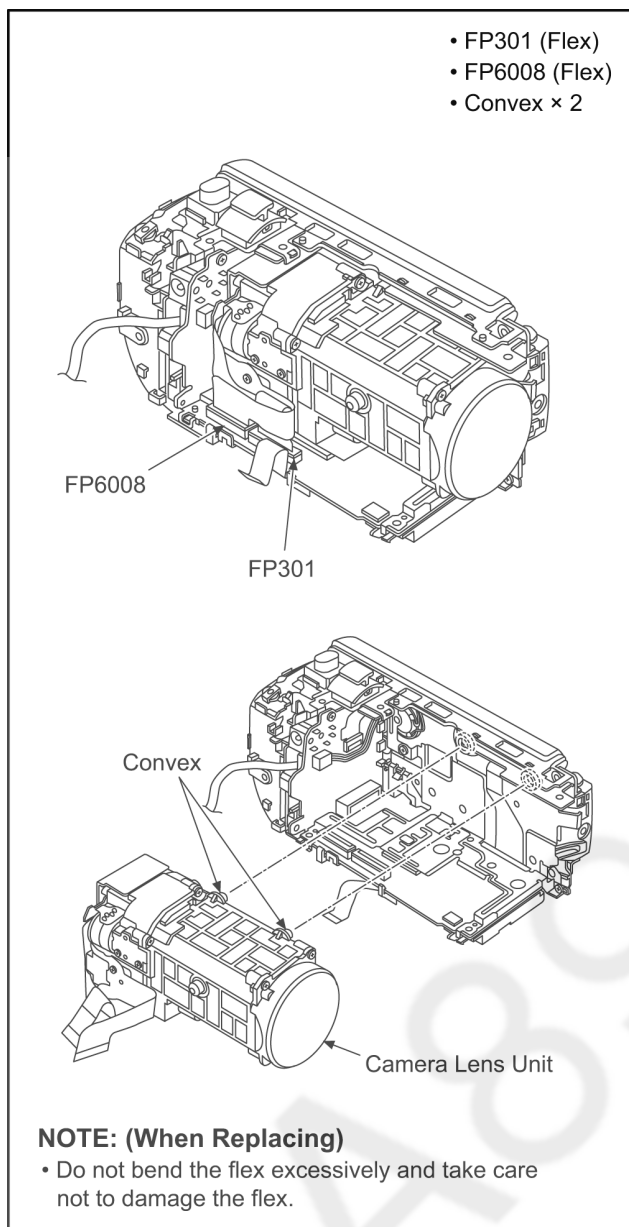

(Fig. D10)

8.3.6. Removal of the Main P.C.B., SD Holder P.C.B.

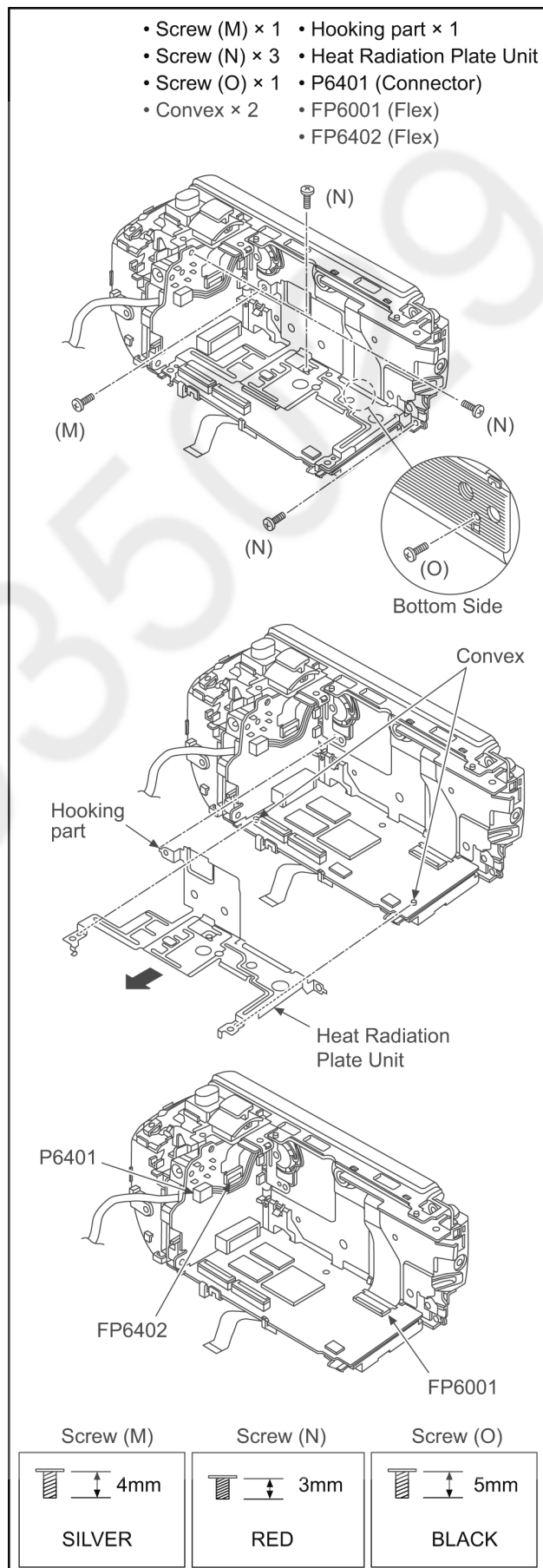

(Fig. D11)

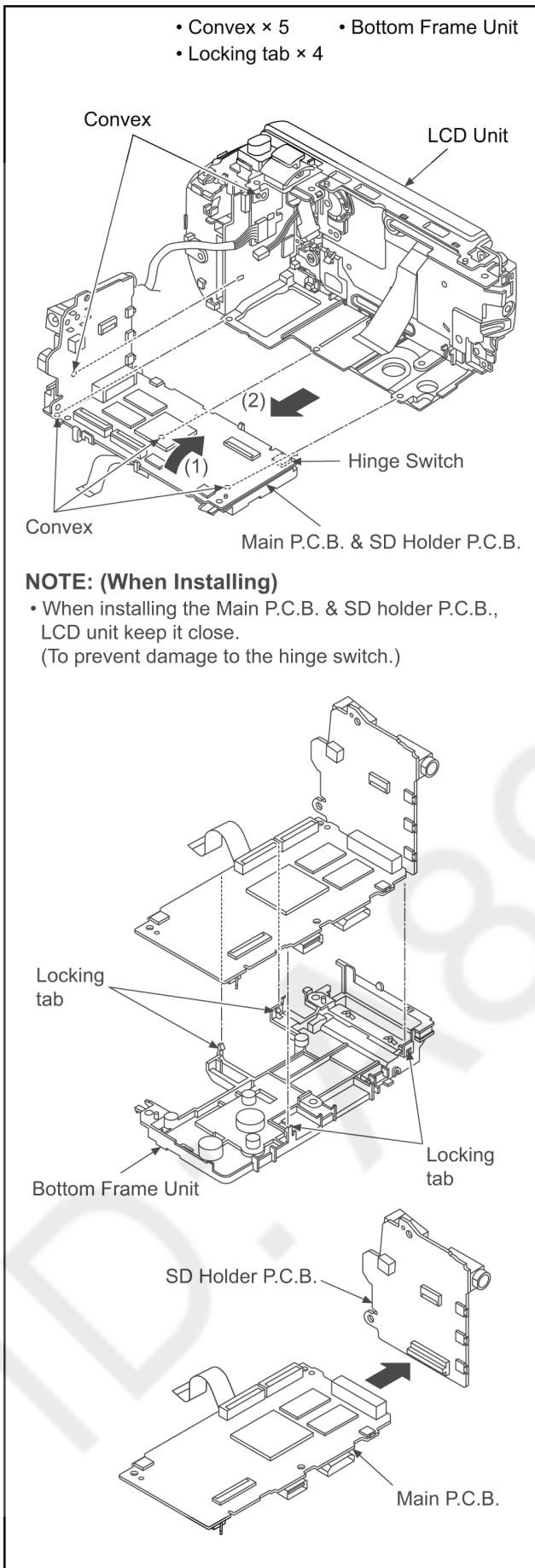

(Fig. D12)

8.3.7. Removal of the Top Operation, BATT. Catcher P.C.B.

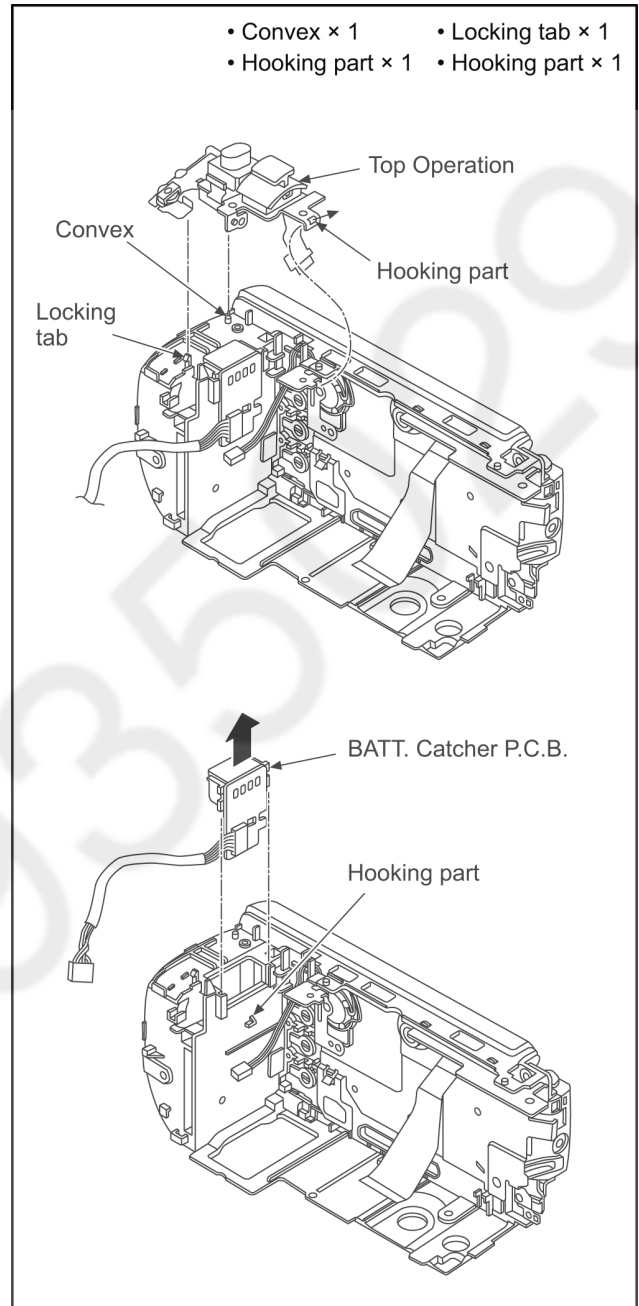

(Fig. D13)

8.3.8. Removal of the R Frame Unit, Speaker, LCD Unit

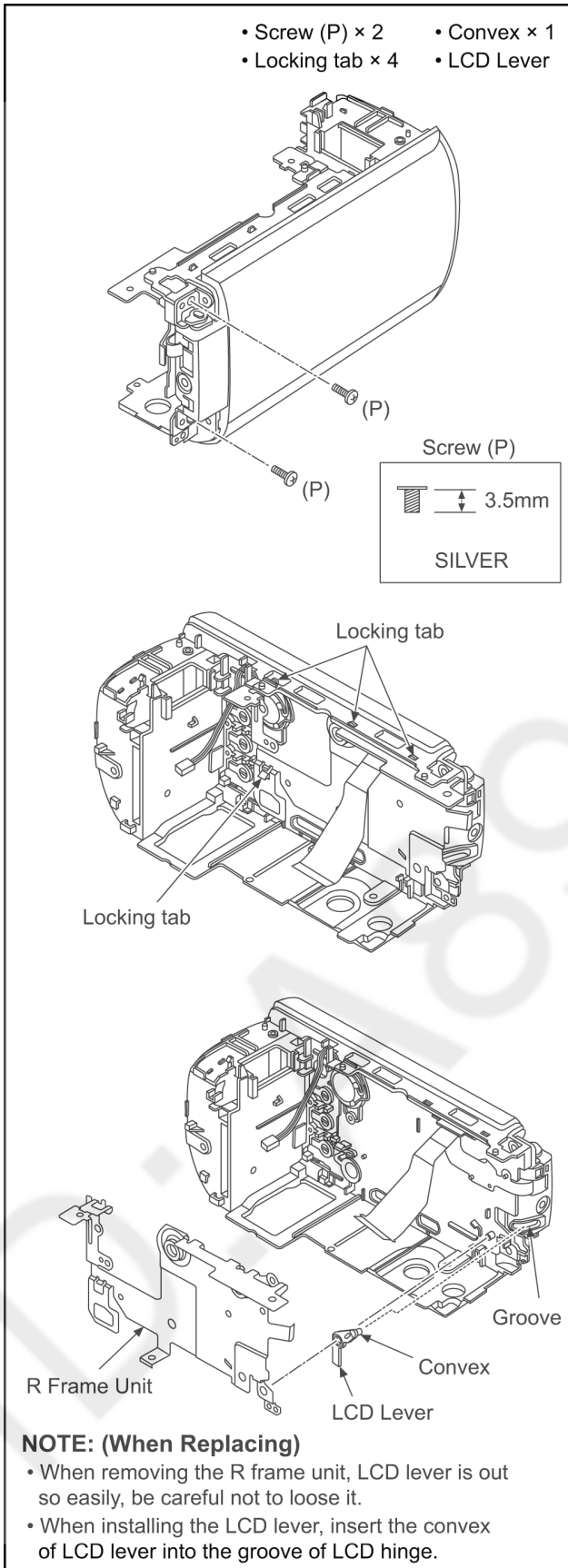

(Fig. D14)

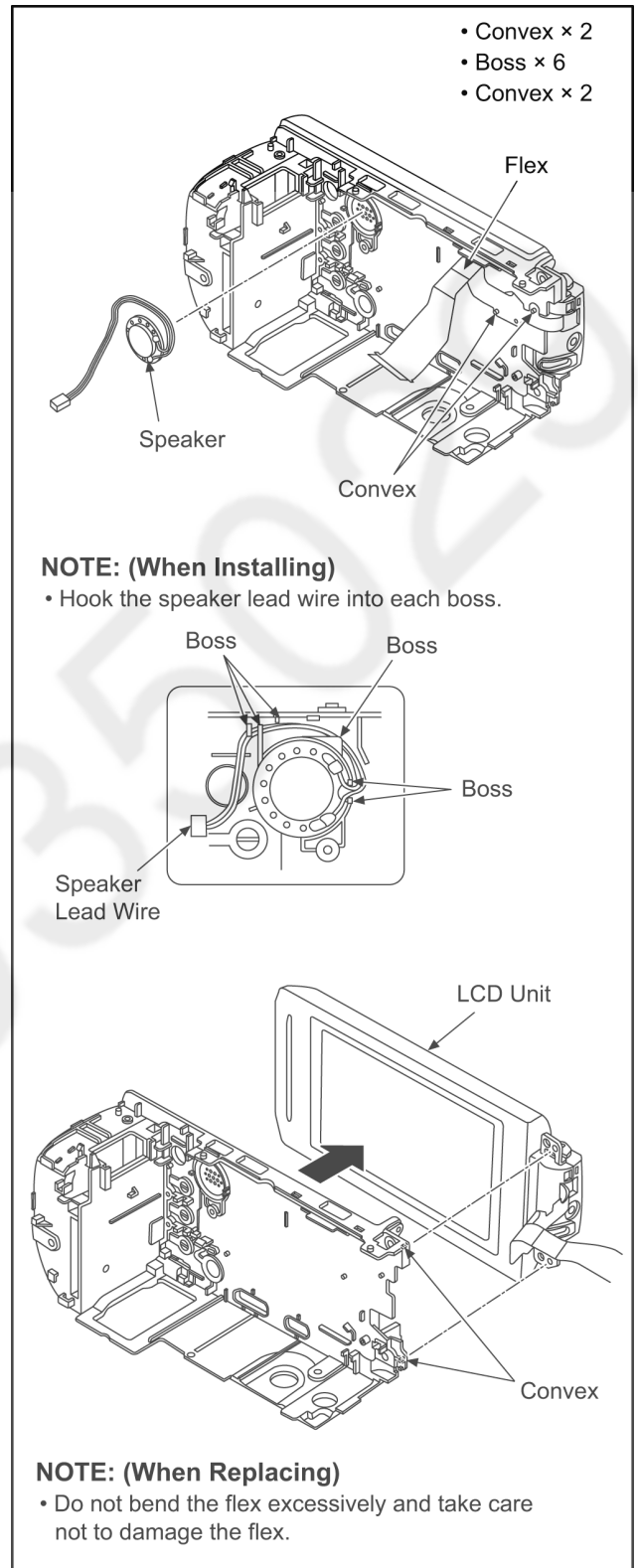

(Fig. D15)

8.3.9. Removal of the Monitor P.C.B., LCD Hinge Unit, Light Guide Plate Unit, LCD Panel Unit

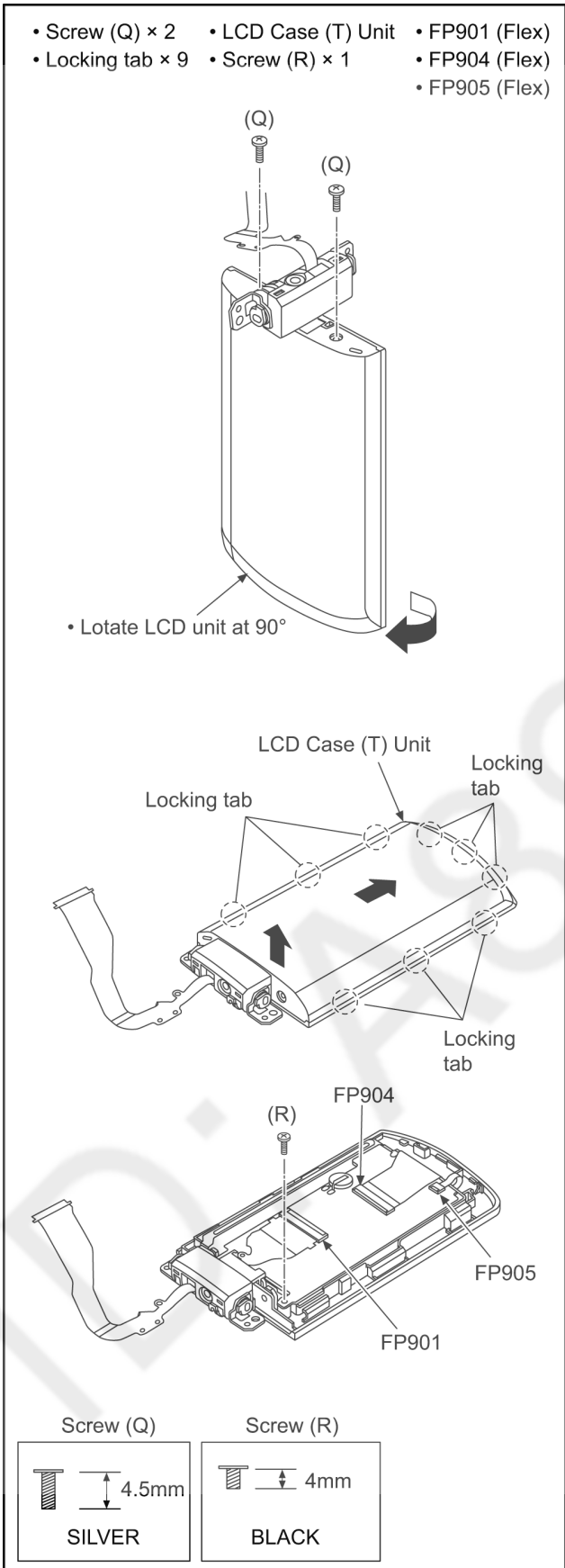

(Fig. D16)

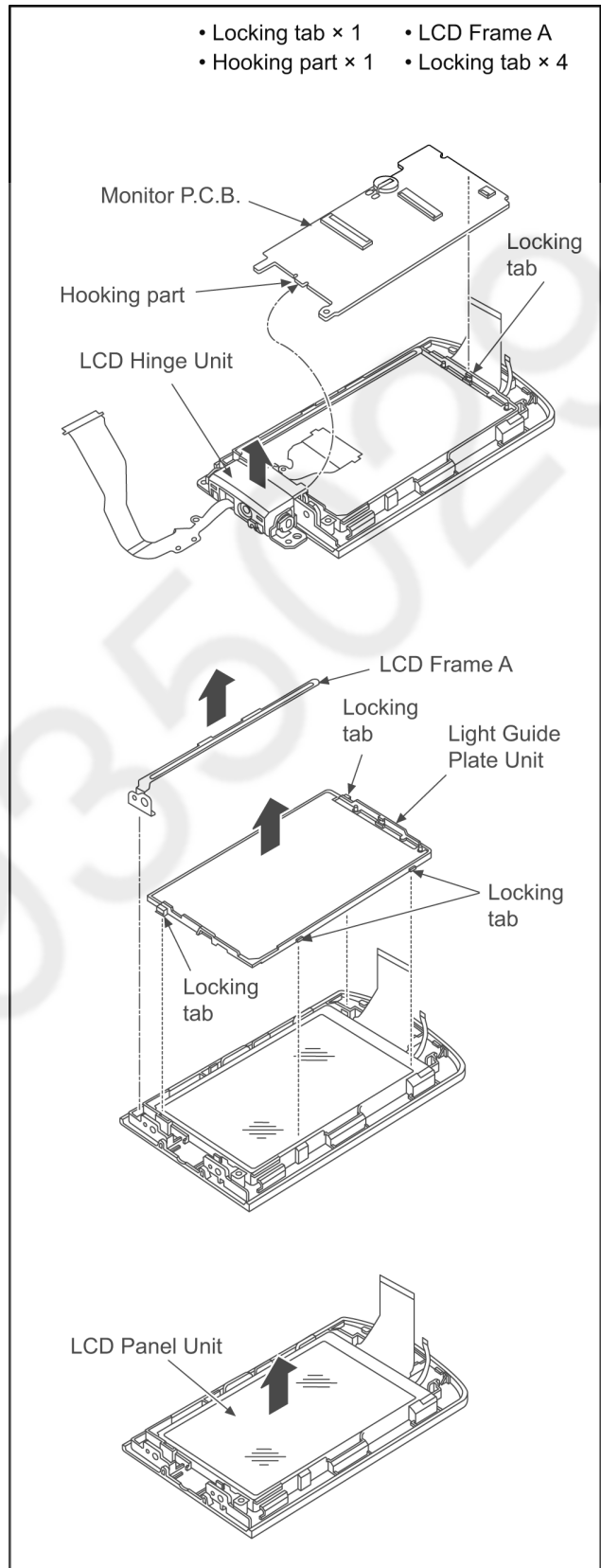

(Fig. D17)

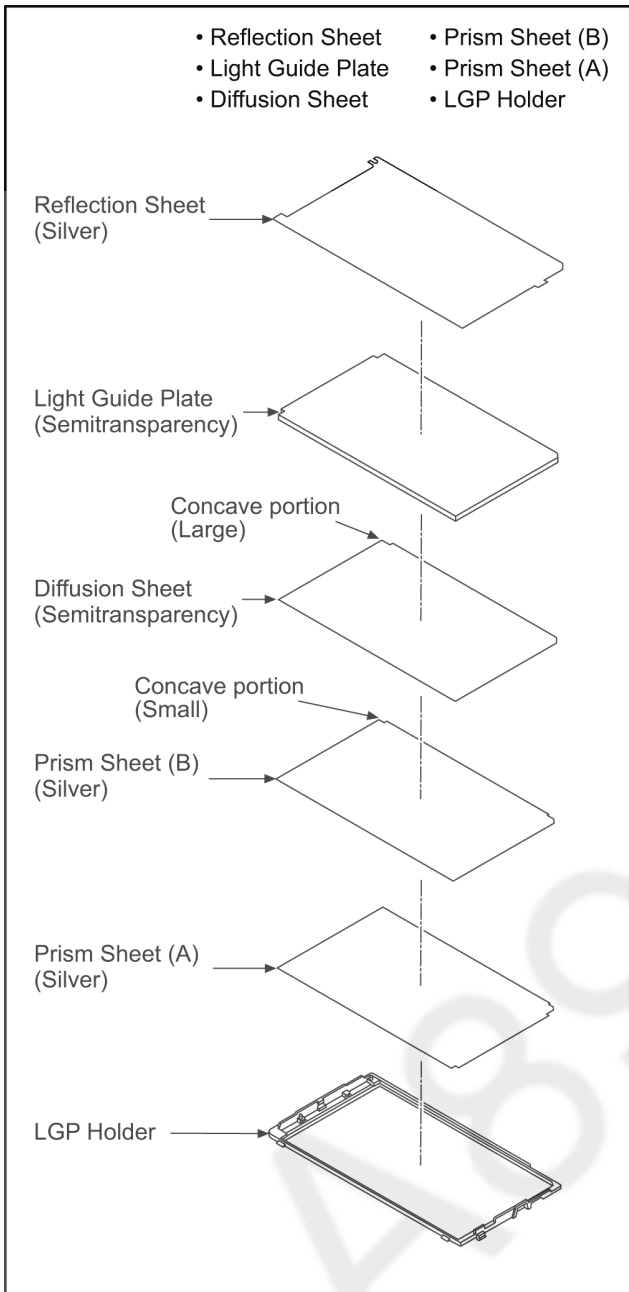

(Fig. D18)

8.3.10. Removal of the Spring Holder, Barrier Lever

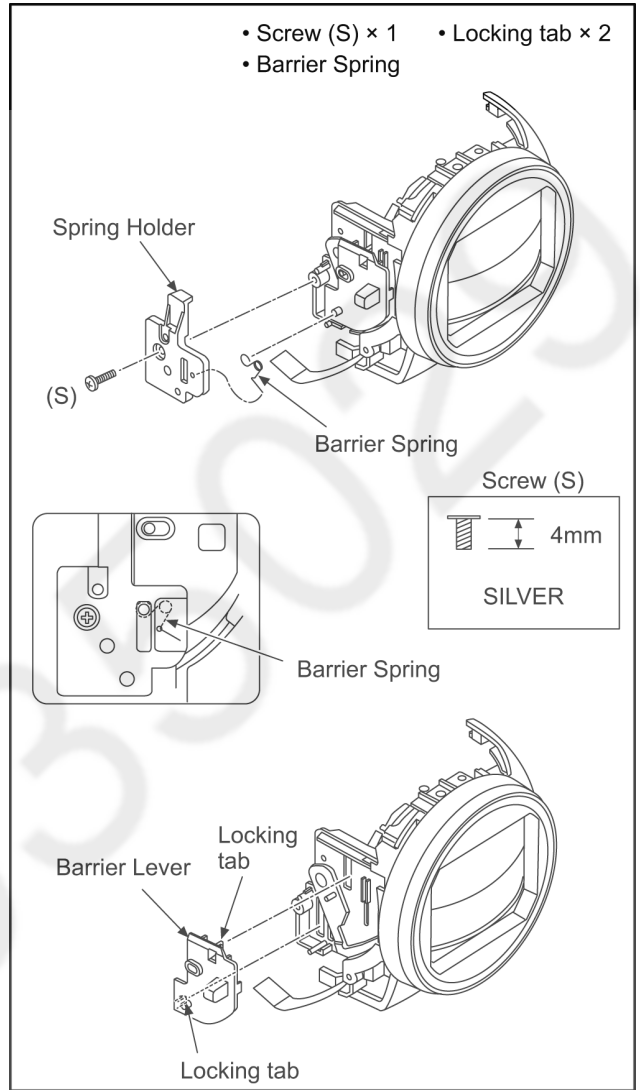

(Fig. D19)

8.3.11. Removal of the Front Base, Barrier R, Barrier F

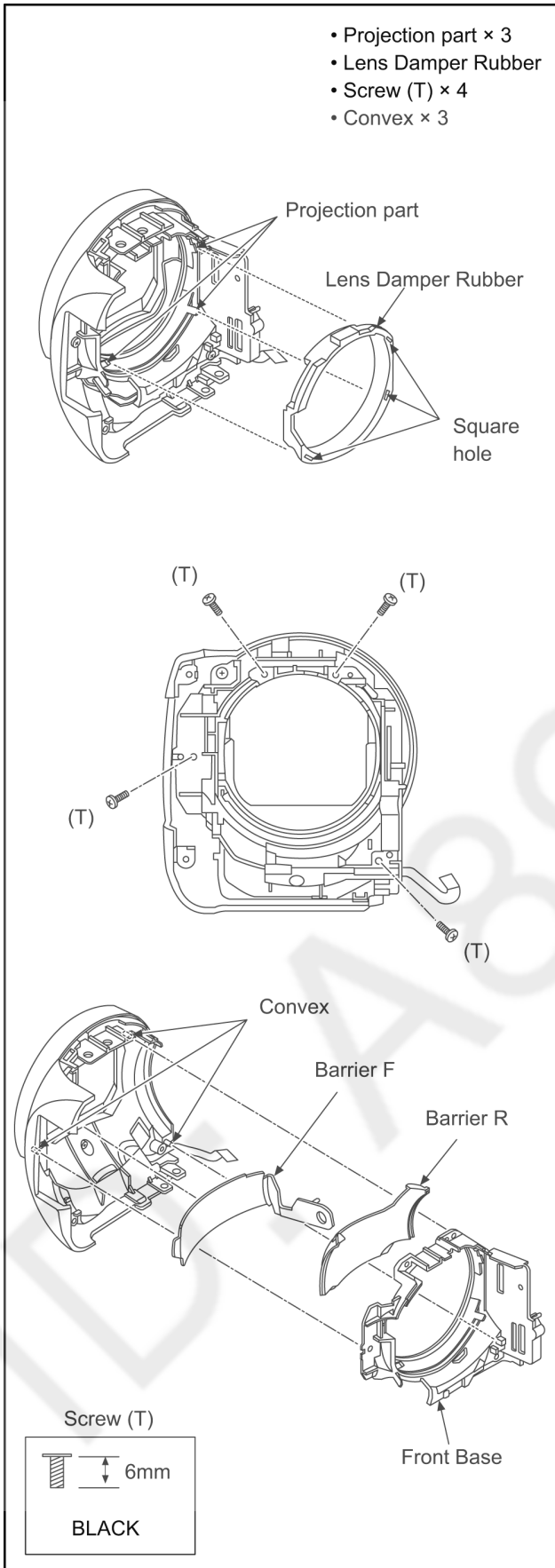

(Fig. D20)

8.3.12. Removal of the Front Case, Mic Cover, Front Ornament Ring, Flare Cut Piece, Microphone Unit

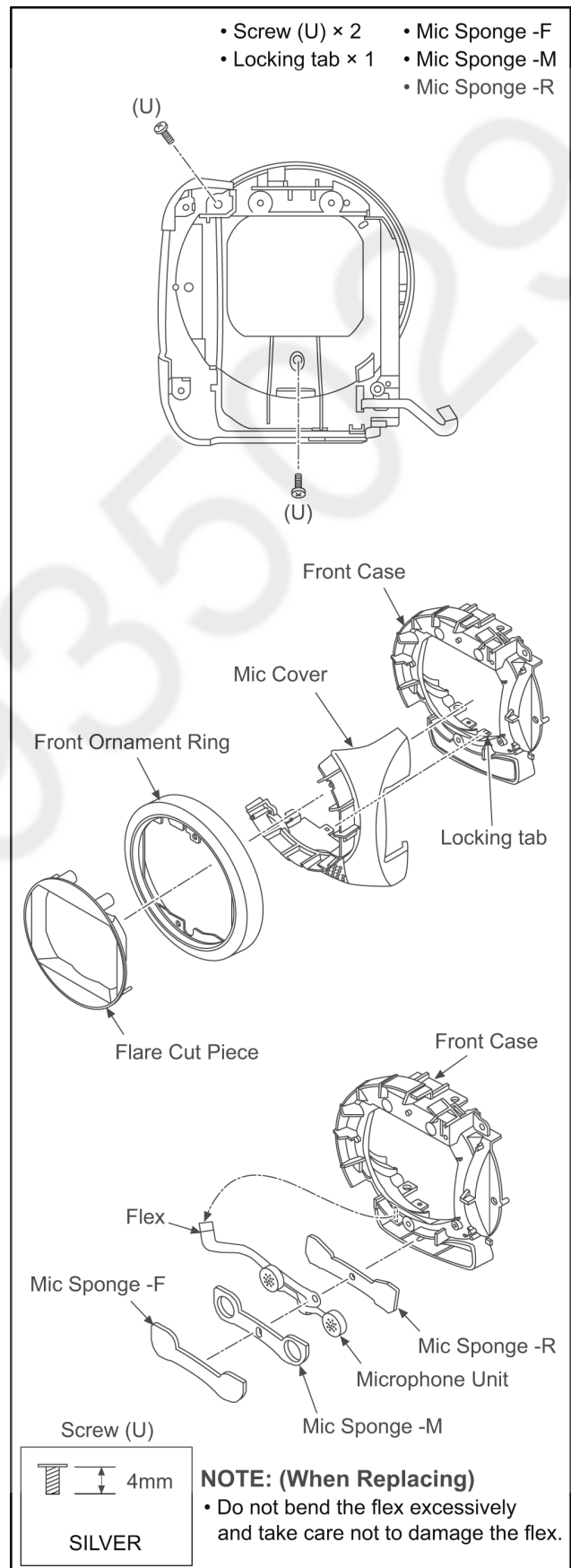

(Fig. D21)

8.3.13. Removal of the MOS Unit, IR Cut Grass

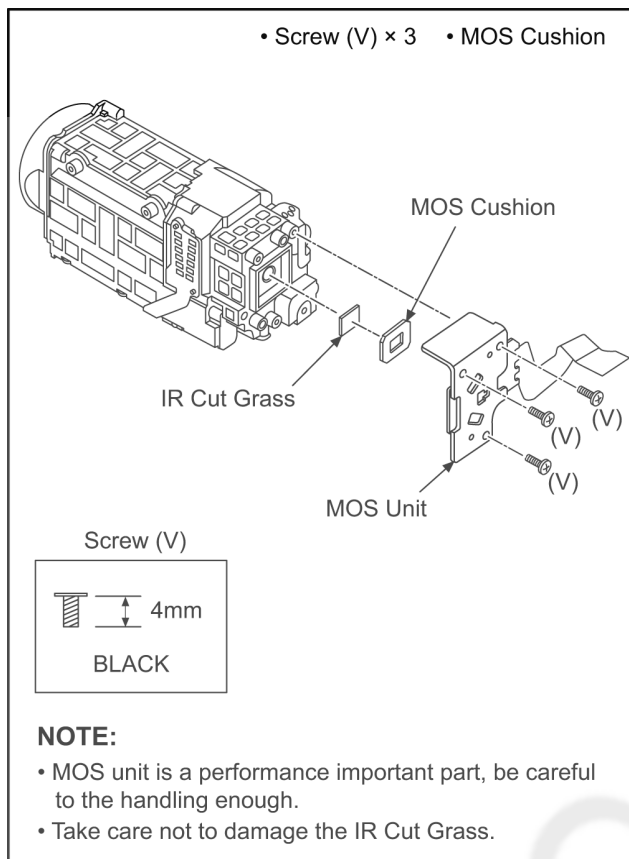

(Fig. D22)

NOTE: (When Installing the MOS Unit)

Necessary Jig:

- Zoom Guide Shaft (VMS8231) × 2

1. Insert the two zoom guide shafts into the holes of the lens unit shown in below.

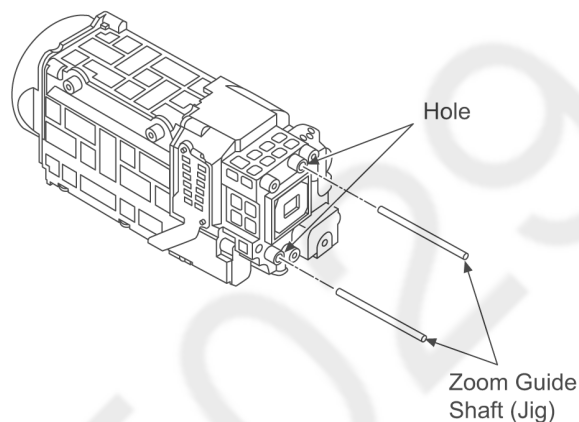

2. Insert the zoom guide shafts through the holes on the MOS fixing angle, fix the position of the MOS unit.

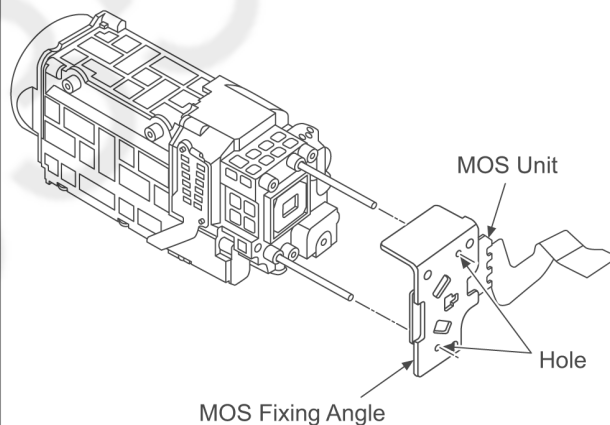

3. Tighten 3 screws and fix the MOS unit.

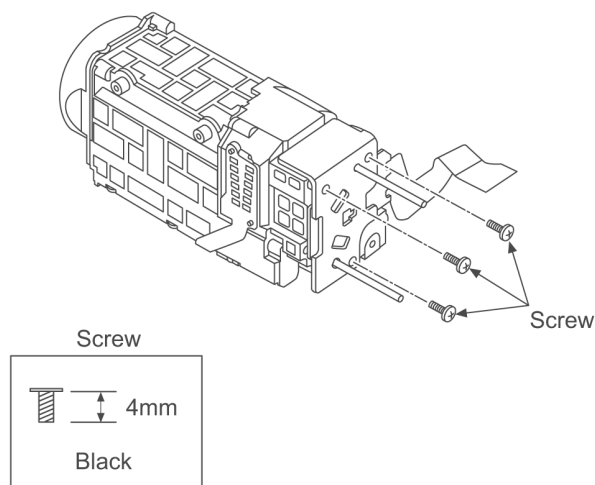

(Fig. D23)

4. Pull out both zoom guide shafts.

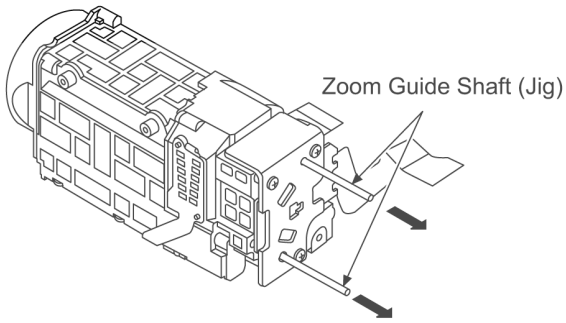

(Fig. D24)

8.3.14. Removal of the 2nd Stepping Motor

- Solder × 16 points
- Convex × 5
- Screw (W) × 3

- Remove the specified soldering points and remove the screw, then lift up the flex over the 2nd stepping motor.
- Do not bend the flex excessively and take care not to damage the flex.

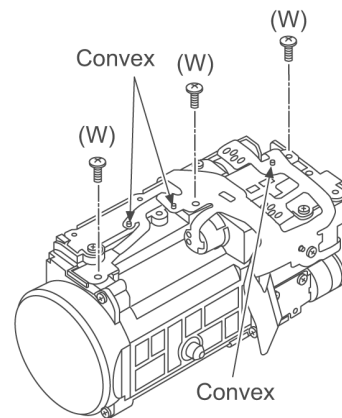
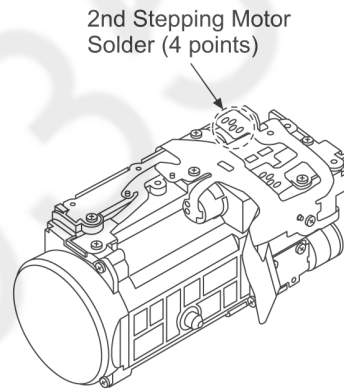
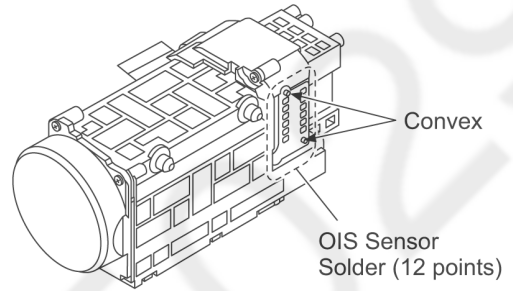

Screw (W)

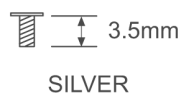

(Fig. D25)

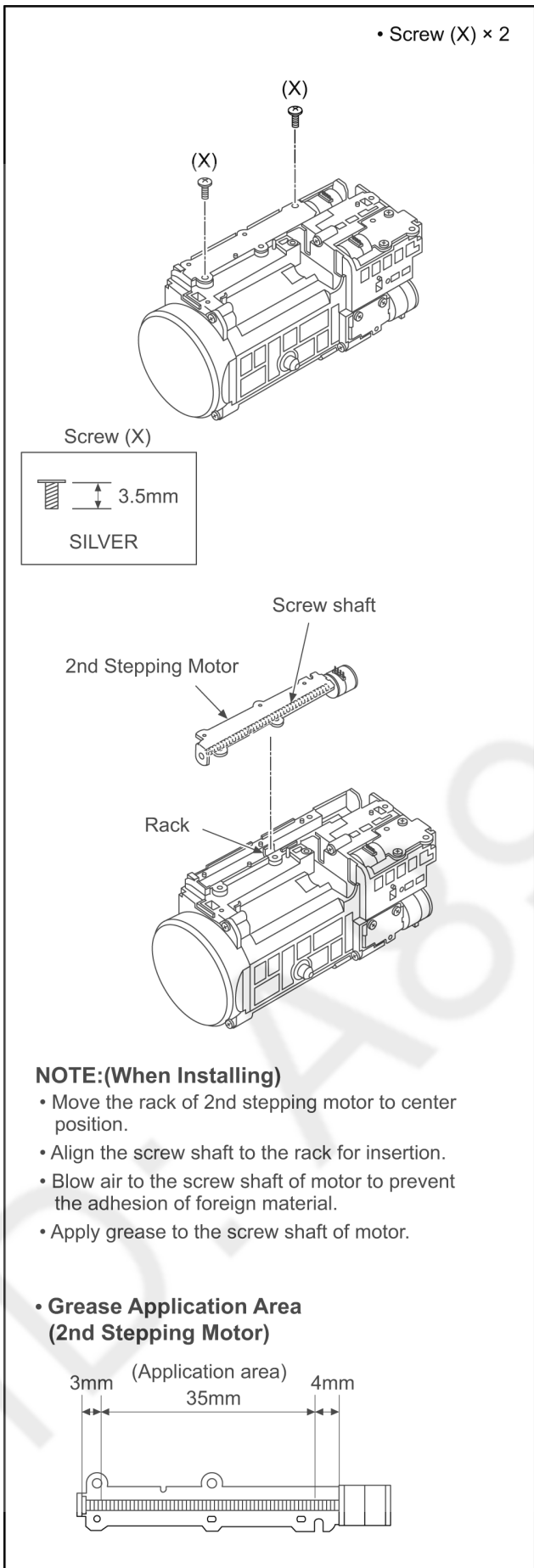

(Fig. D26)

8.3.15. Removal of the 3rd Stepping Motor

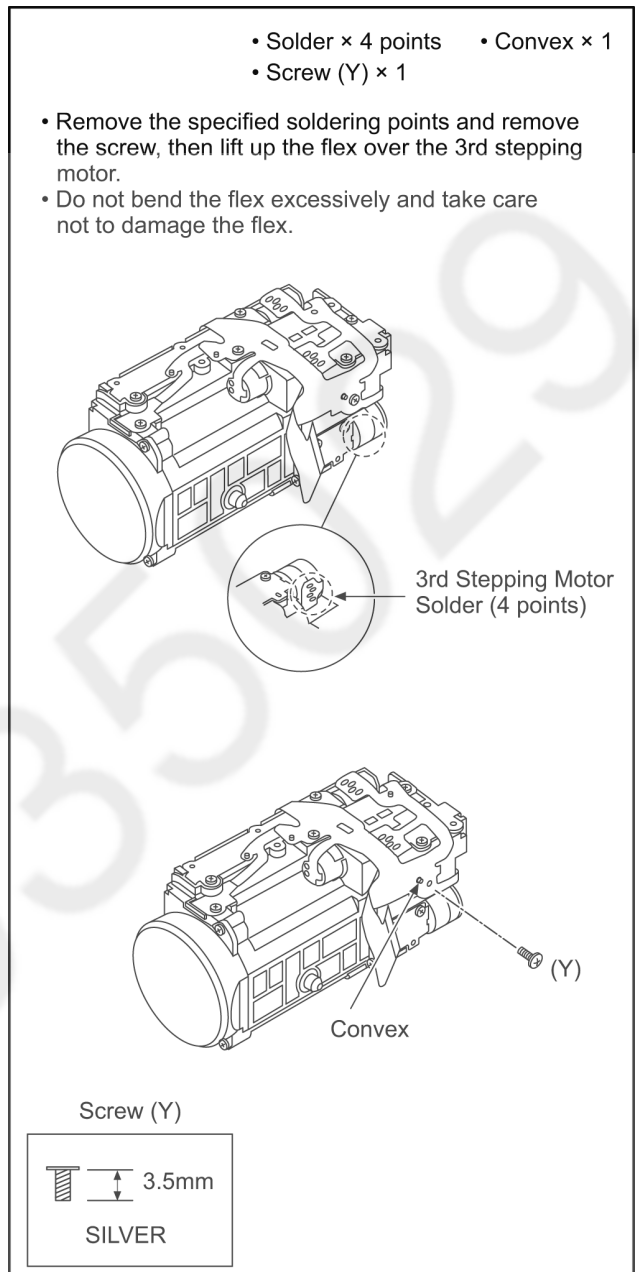

(Fig. D27)

8.3.16. Removal of the Focus Motor

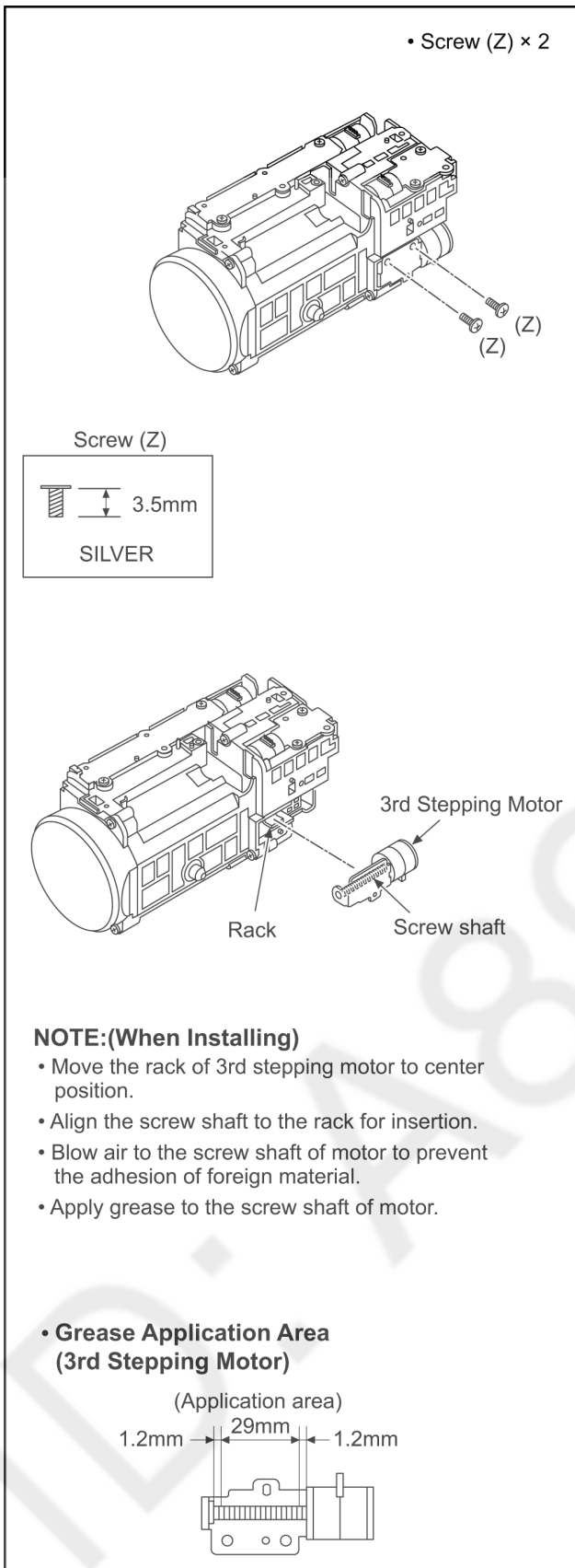

(Fig. D28)

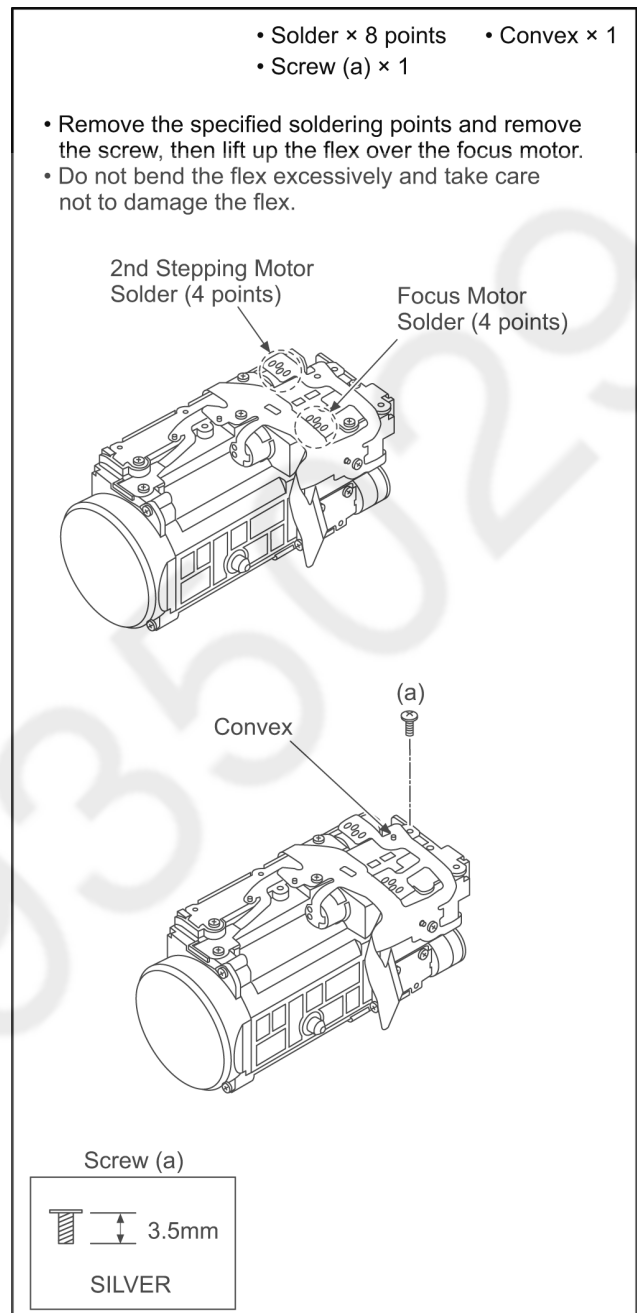

(Fig. D29)

• Screw (b) × 2

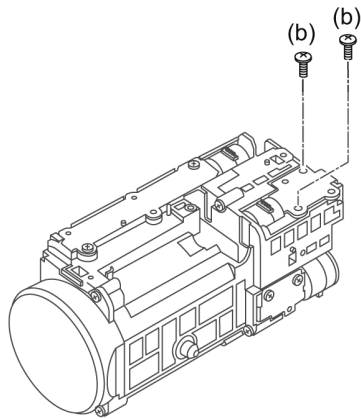

Screw (b)

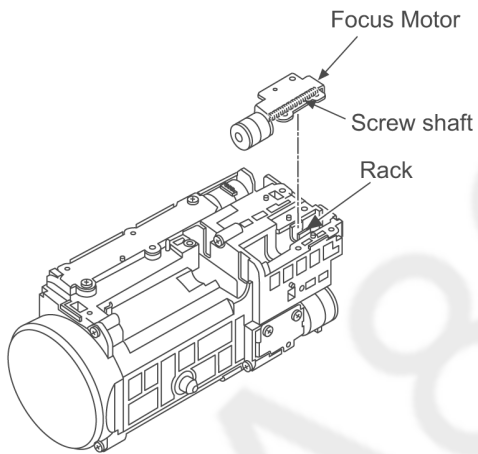
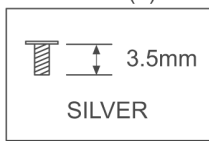

NOTE:(When Installing)

- Move the rack of focus motor to center position.
- Align the screw shaft to the rack for insertion.
- Blow air to the screw shaft of motor to prevent the adhesion of foreign material.
- Apply grease to the screw shaft of motor.

• Grease Application Area (Focus Motor)

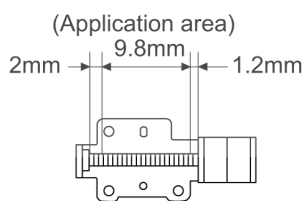

(Fig. D30)

9 Measurements and Adjustments

9.1. Electric Adjustment

- Adjustment method is different from a conventional High definition video camera.
- An exclusive jig are necessary for electric adjustment.
- Connection method of the main unit and an exclusive adjustment jig as follows.

Figure of connection

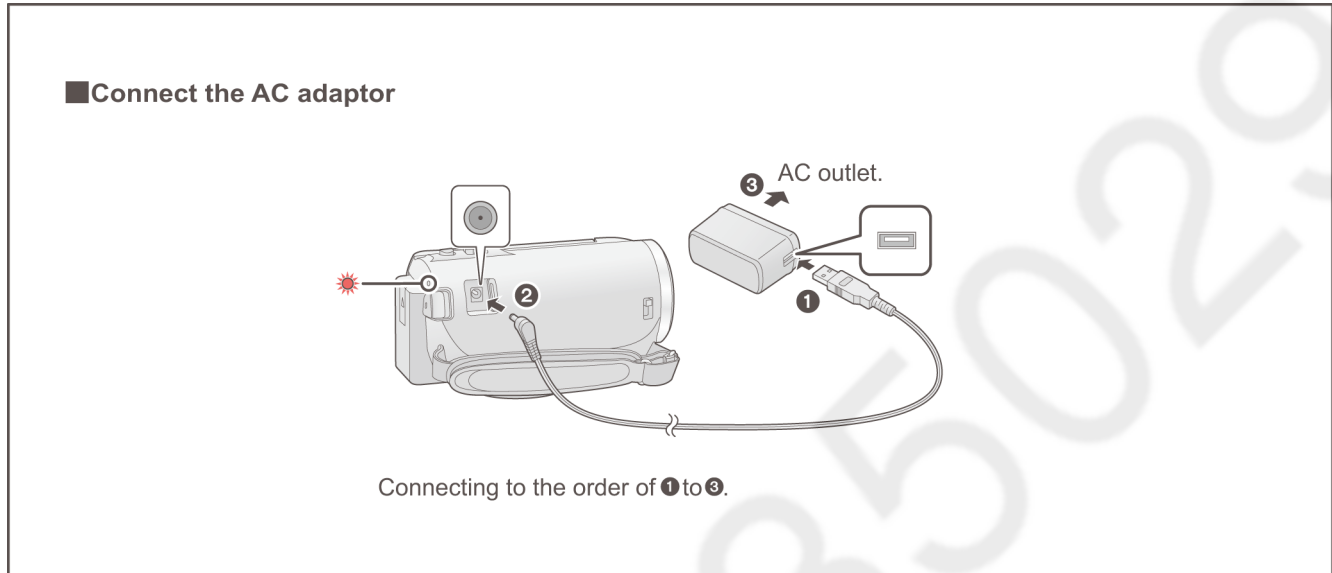
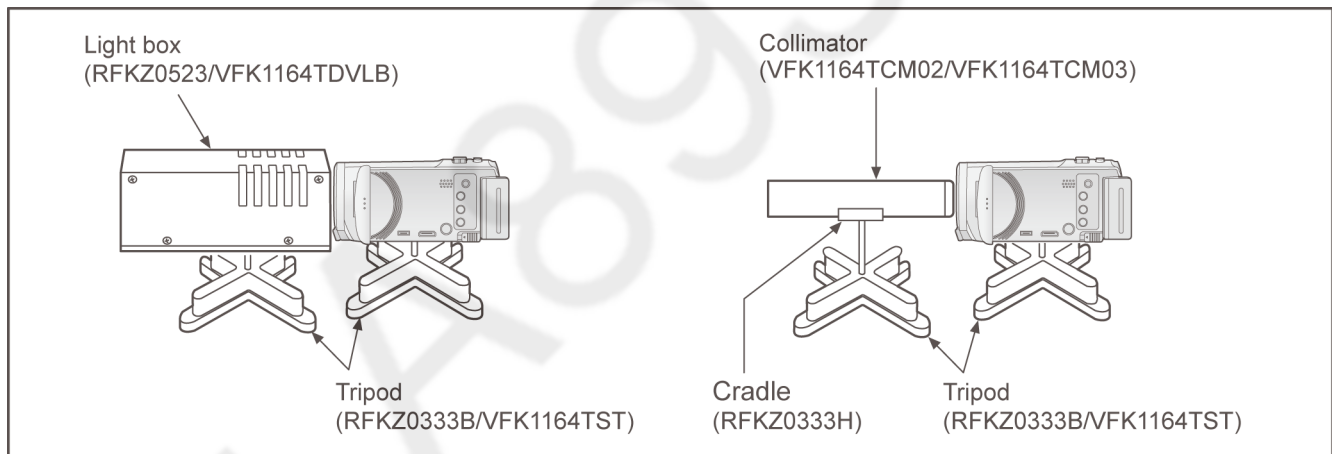

Figure of image when adjustment



Part Number of jig

1. Basic Jig

Item	Contents
AC adaptor	Banded with camcorder
AC Cable	Banded with camcorder

2. Optical Jig for Camera Adjustment

Item	Part number	Remarks
Light box	VFK1164TDVLB/RFKZ0523*	Need external power supply: 12V \pm 0.1V /1.8A or over
Collimator with focus chart	VFK1164TCM02/VFK1164TCM03	Same as DSC
CC filter	3100K/5100K VFK1164CC10G	Need 2 set. For indoor/outdoor white balance adjustment
C2 Filter	5100K VFK1164LBB2	For outdoor white balance adjustment
C8 Filter	5100K VFK1164LBB8	For outdoor white balance adjustment
ND Filter 0.1	3100K VFK1164ND01	For indoor white balance adjustment
ND Filter 0.6	3100K VFK1164ND06	For indoor white balance adjustment

* RFKZ0523 (same as DSC) is recommended.

9.1.1. About Light Box

When using VFK1164TDVLB Light Box

If using VFK1164TDVLB Light Box, remove the lens connection ring by loosening thumbscrew and three hexagon screws.

* RFKZ0523 Light Box has no lens connection ring.

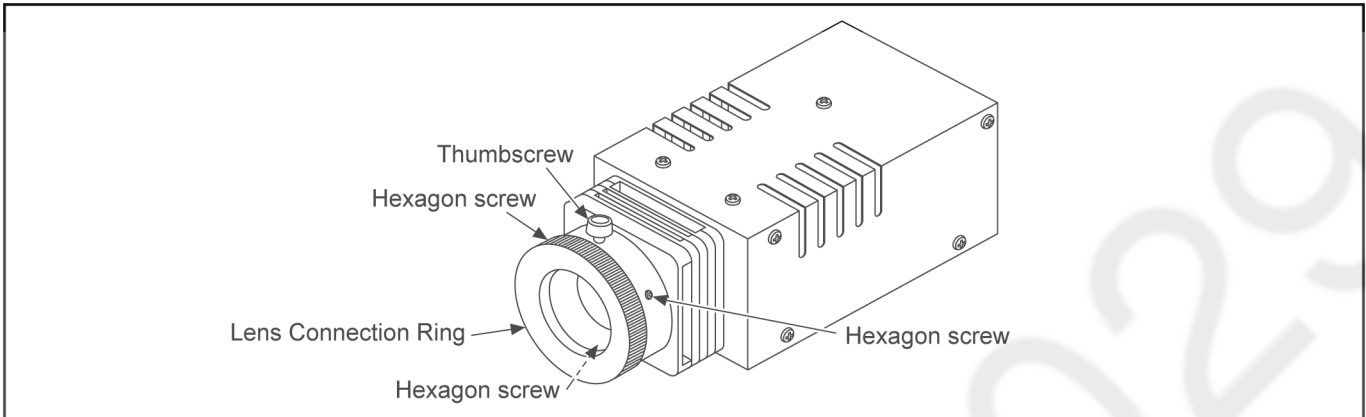

How to remove the Front Hood

In order to utilize maximum of the diffusing surface of light box, some adjustment items need the distance between diffusing surface of light box and camera body becomes several centimeters.

Before the adjustments, remove the front hood of light box following steps below.

[For VFK1164TDVLB Light Box]

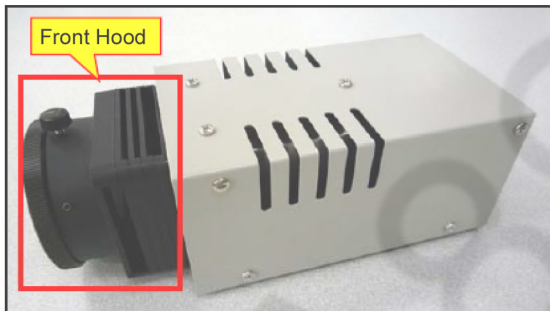

(1) Unscrew the 8 screws.
Slide the body case, then lift it up.

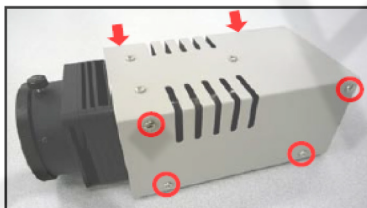

(2) Unscrew the 4 screws.

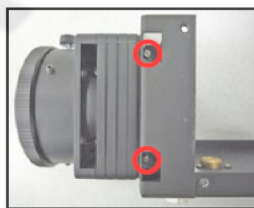

(3) Remove the front hood. Install the body case, then tighten the 8 screws.



[For RFKZ0523 Light Box]

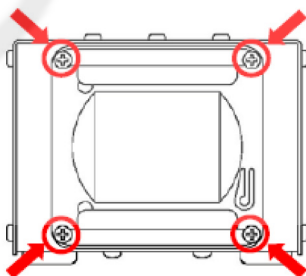

Unscrew the 4 screws, then remove the front hood.

9.1.2. Adjustment Items

Adjustment item as follows.

Replacement part		Adjustments					Settings	
		Camera Adjutments ^{*1}	Zoom Tracking Adjustment	Indoor White Balance Adjustment	Outdoor White Balance Adjustment	Touch Panel Calibration	Model setting	Factory settings
		○	○	○	○	-	○	○
MAIN P.C.B.	IC301	MOS 2.8V LDO	-	-	○	○	-	-
	IC701	LENS DRIVE IC	○	○	-	-	-	-
	IC704	GYRO 3V LDO	○	-	-	-	-	-
	IC1001	7CH DC/DC IC	○	○	○	○	-	-
	IC3404	FLASH ROM	○	○	○	○	-	○
SD HOLDER P.C.B.		○	-	-	-	-	-	-
	IC6401	PIT/YAW GYRO	○	-	-	-	-	-
LENS UNIT		○	○	○	○	-	-	-
MOS UNIT		○	○	○	○	-	-	-
LCD PANEL UNIT		-	-	-	-	○	-	-

*1...IRIS adjustment, OIS hall amp adjustment, Missing pixels compensation, OIS gyro adjustment, AGS adjustment
Zoom hysteresis adjustment

9.1.3. Adjustment Procedure

All adjustments except “Touch Panel Calibration”, “Factory Setting” and “NFC Initialization” performs using “14 Adjustment function for the service” in service mode menu.

“Touch Panel Calibration” is performed using 16 of service mode menu and “Factory Setting” is performed using 1, “NFC Initialization” is performed using 17 of service mode menu. Refer to “6 Service mode” and “10 Factory Setting”.

[Execute adjustment function for service]

1. While the power is turned OFF, keep pressing the “Power” button, “Zoom lever” to W side and “Recording/Playback” button for more than 3 seconds until the top screen of the Service Mode Menu being displayed.

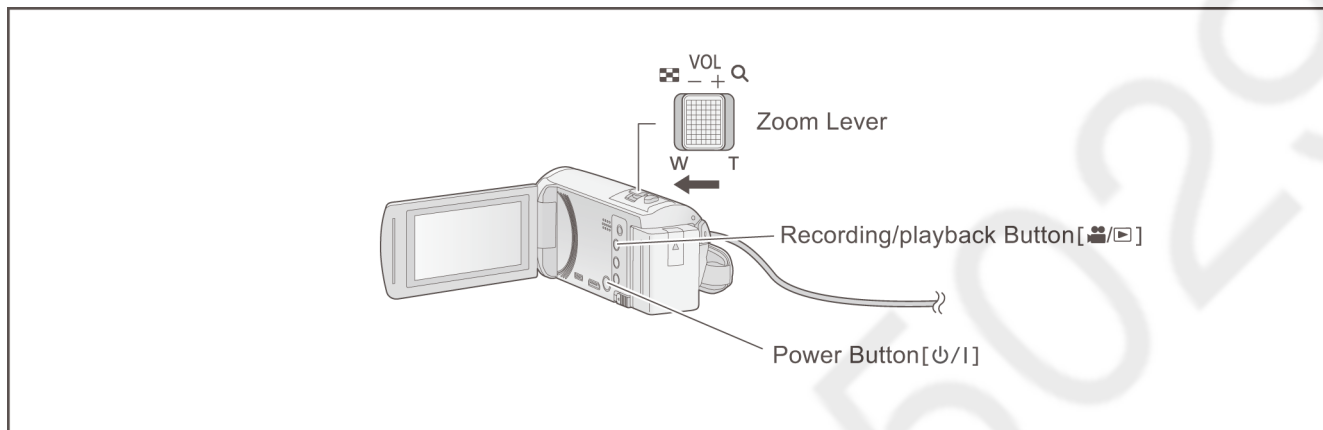

2. Touch the ▼ twice then touch the [14] of LCD.
3. Touch the [YES] of LCD.

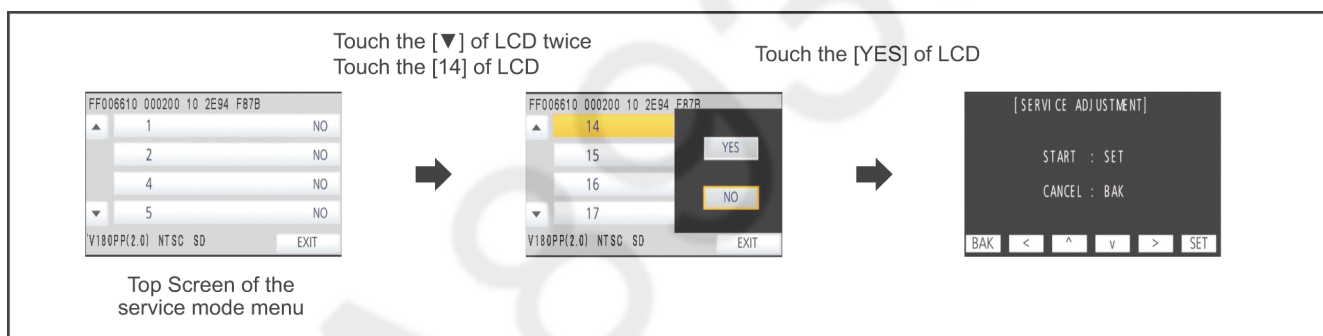

[Adjustment Procedure]

Adjustments and settings are performed following order:

1. Model setting
2. Filename setting for backup to SD card
3. Backing up adjustment data to SD card
4. Checking switches
5. Camera adjustment
6. Zoom/tracking adjustment
7. Indoor white balance adjustment
8. Outdoor white balance adjustment

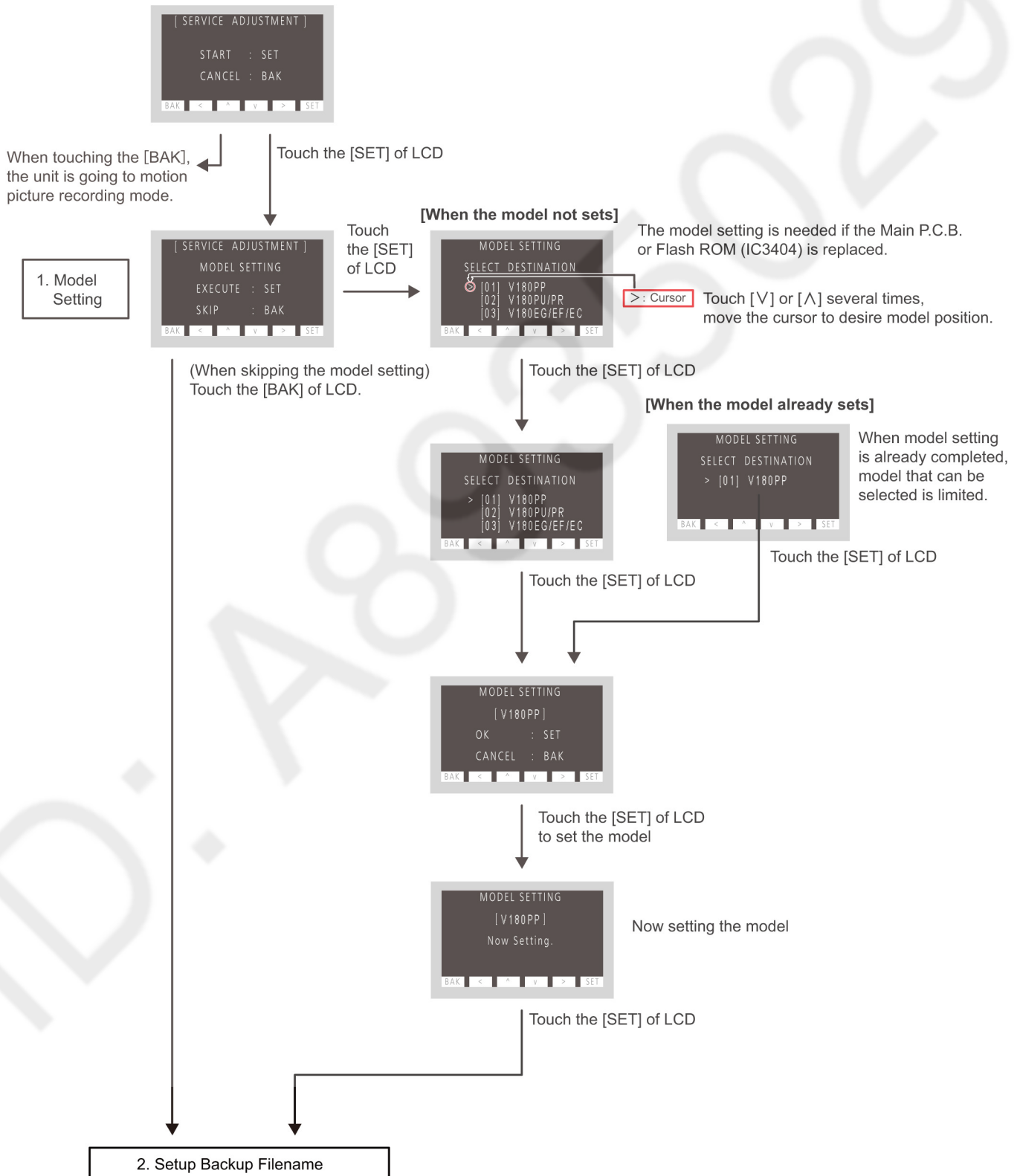

2. Setup Backup Filename

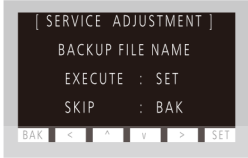

Touch the [SET] of LCD



- < : Move cursor 1 position left
- > : Move cursor 1 position right
- ^ : Increase 1 character (0→1→2→...)
- v : Decrease 1 character (0→Z→Y→...)

[] : Cursor

(When skipping the setup)
Touch the [BAK] of LCD.
Backup filename: 00000000000 (Default)
or
xxxxxxxxxxx (Previously set)
(The backup filename is stored in Flash ROM.)

Touch the [SET] of LCD

For example, "ABCDE123456" as the specified backup filename;
First, a new folder (folder name is "\V180" for HC-V180, "\V180" for HC-V180.) is created at root folder of SD card.
Next, a new folder that is named first 5 letter of specified backup filename is created inside of model-named folder.
Then, the adjustment data backup file which filename is last 6 letter of specified backup filename is created inside of above folder.

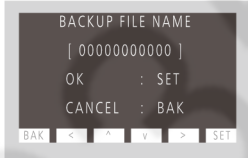

Touch the [BAK] of LCD

Touch the [SET] of LCD

3. Backup Execution

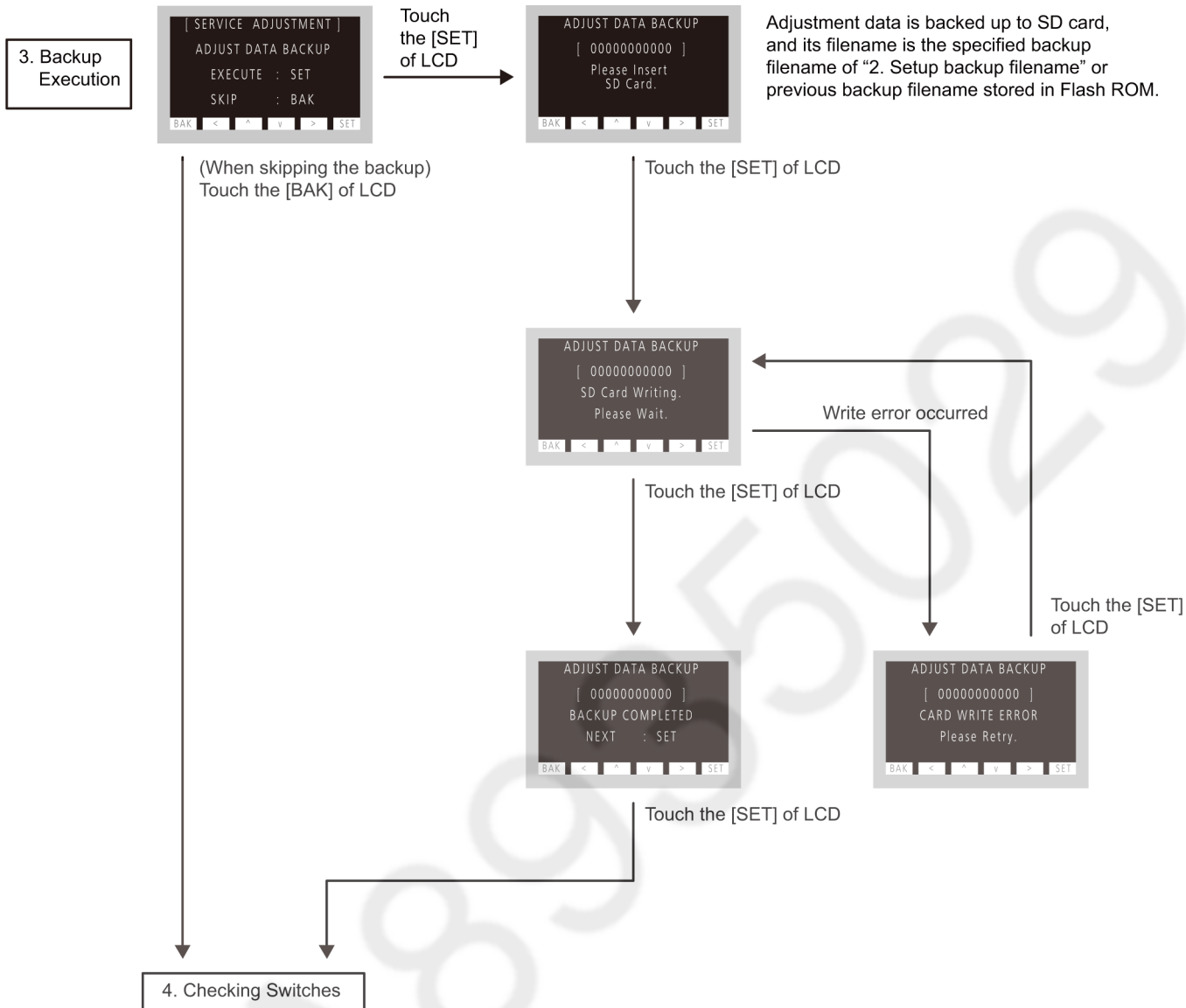

4. Checking Switches

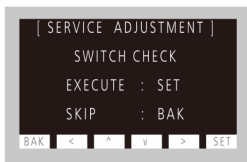

Touch the [SET] of LCD



Pressing the switches, Knobs, levers, the corresponding each white rectangle "□" will turn to green "■".

(When skipping the checks)
Touch the [BAK] of LCD



When all white rectangle "□" change to green "■", the unit goes to next adjustment stage automatically.

5. Camera Adjustment

< Switches arrangement >

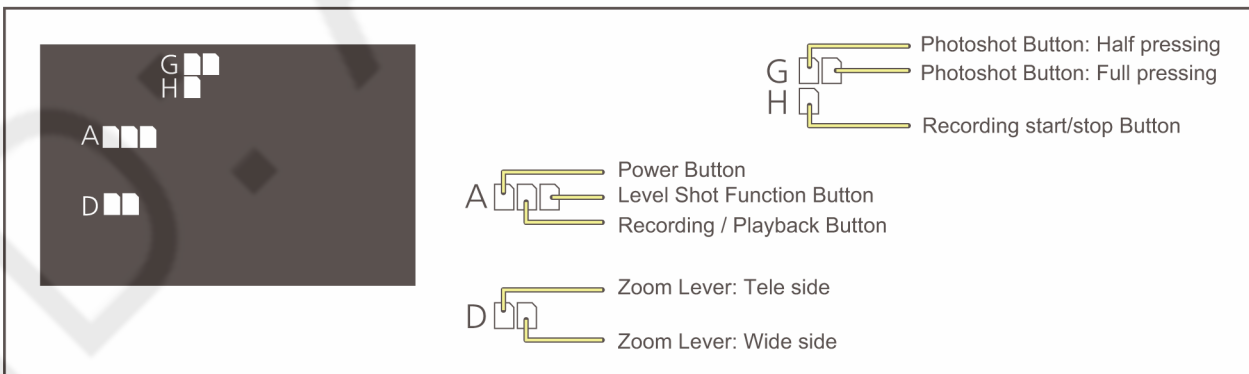

5. Camera Adjustment

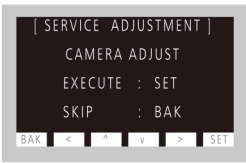

Touch the [SET] of LCD

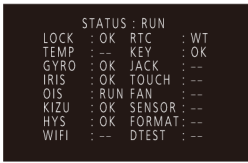

WT : Waiting for Adjust
 RUN : Now adjusting
 OK : Normal Condition
 NG : Abnormal Condition
 -- : Excluded

(When skipping the adjustment)
 Touch the [BAK] of LCD

Adjustment Item	
LOCK	Confirmation that the lens lock has not occurred.
TEMP	(Excluded)
GYRO	Result of Gyro DC compensation.
IRIS	Result of Iris adjustment.
OIS	Result of OIS adjustment.
KIZU	Result of missing pixels compensation.
HYS	Result of zooming hysteresis compensation.
WIFI	(Excluded)
RTC	Result of the RTC working normally.
KEY	Confirmation that all switches on the unit are released.
JACK	(Excluded)
TOUCH	(Excluded)
FAN	(Excluded)
SENSOR	(Excluded)
FORMAT	(Excluded)
DTEST	(Excluded)

6. Zoom/Tracking Adjustment

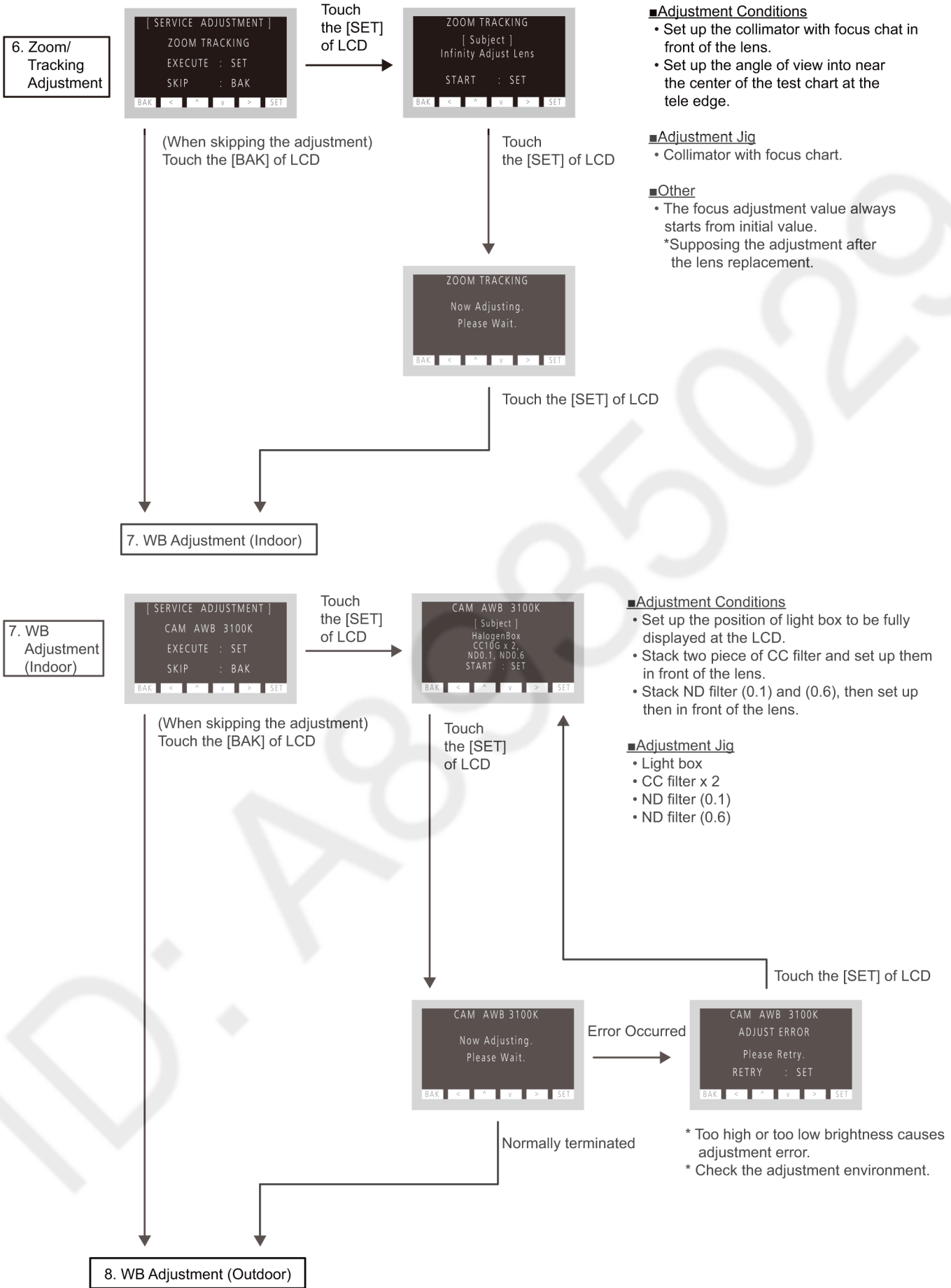

8. WB Adjustment (Outdoor)

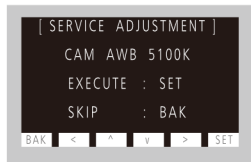

Touch the [SET] of LCD



Touch the [SET] of LCD

■ Adjustment Conditions

- Set up the position of light box to be fully displayed at the LCD.
- Stack two piece of CC filter and set up them in front of the lens.
- Stack C2 filter and C8 filter, then set up them in front of the lens.

■ Adjustment Jig

- Light box
- CC filter x 2
- C2 filter
- C8 filter

(When skipping the adjustment)
Touch the [BAK] of LCD

Touch the [SET] of LCD



Error Occurred



Normally terminated

- * Too high or too low brightness causes adjustment error.
- * Check the adjustment environment.



Press the power button and turn off. Adjustment completed.

10 Factory Setting

10.1. How To Turn On The Factory Settings?

1. While the power is turned OFF, keep pressing the “Power” button, “Zoom lever” to W side and “Recording/Playback” button for more than 3 seconds until the top screen of the Service Mode Menu being displayed.

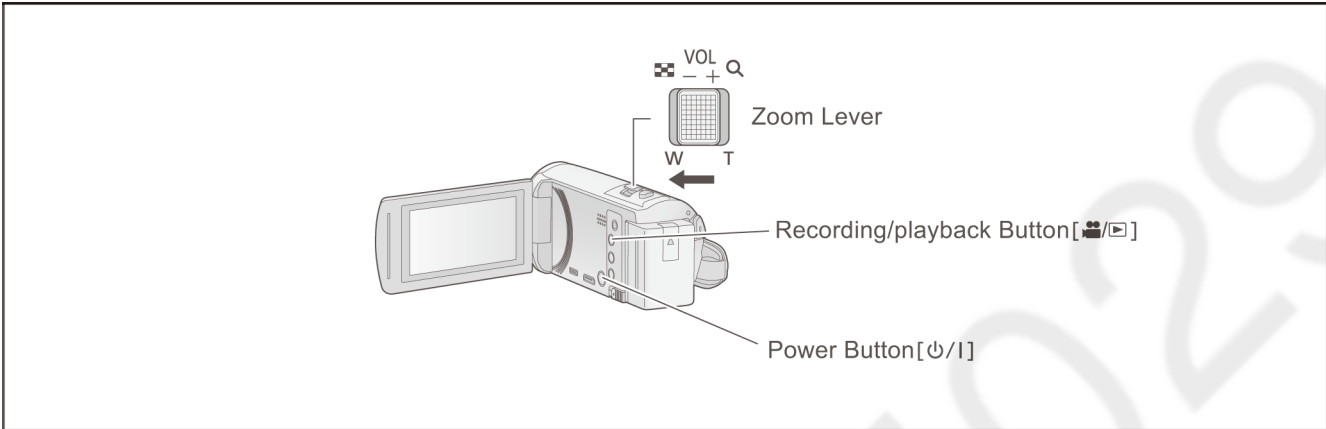

2. Touch the [1] of LCD.
3. Touch the [YES] of LCD.
4. After few seconds “END” is displayed on LCD monitor. Cutting of battery connection or AC power supply connection as a completion of the “FACTORY SETTINGS”.

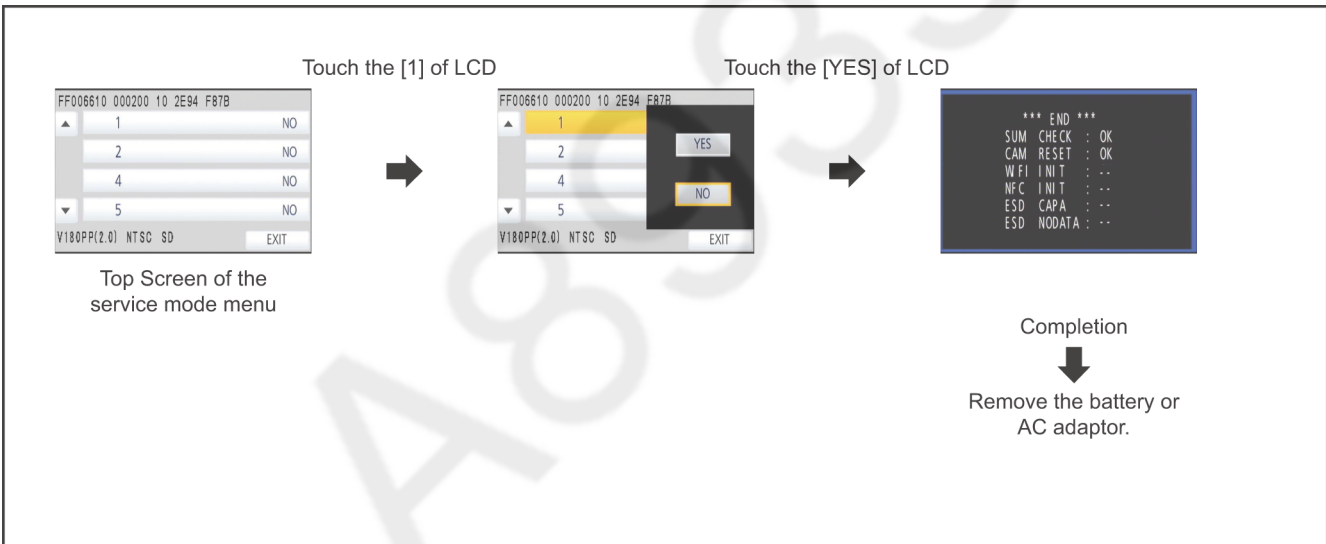

10.2. What Is The Factory Settings?

The factory settings clean up and/or refresh the following settings.

1. Setting values of menu.
2. Clear the time and date setting.

The setting position of factory settings:

Name	Setting position
Lens Barrier	Open

11 Block Diagram

11.1. Overall Block Diagram

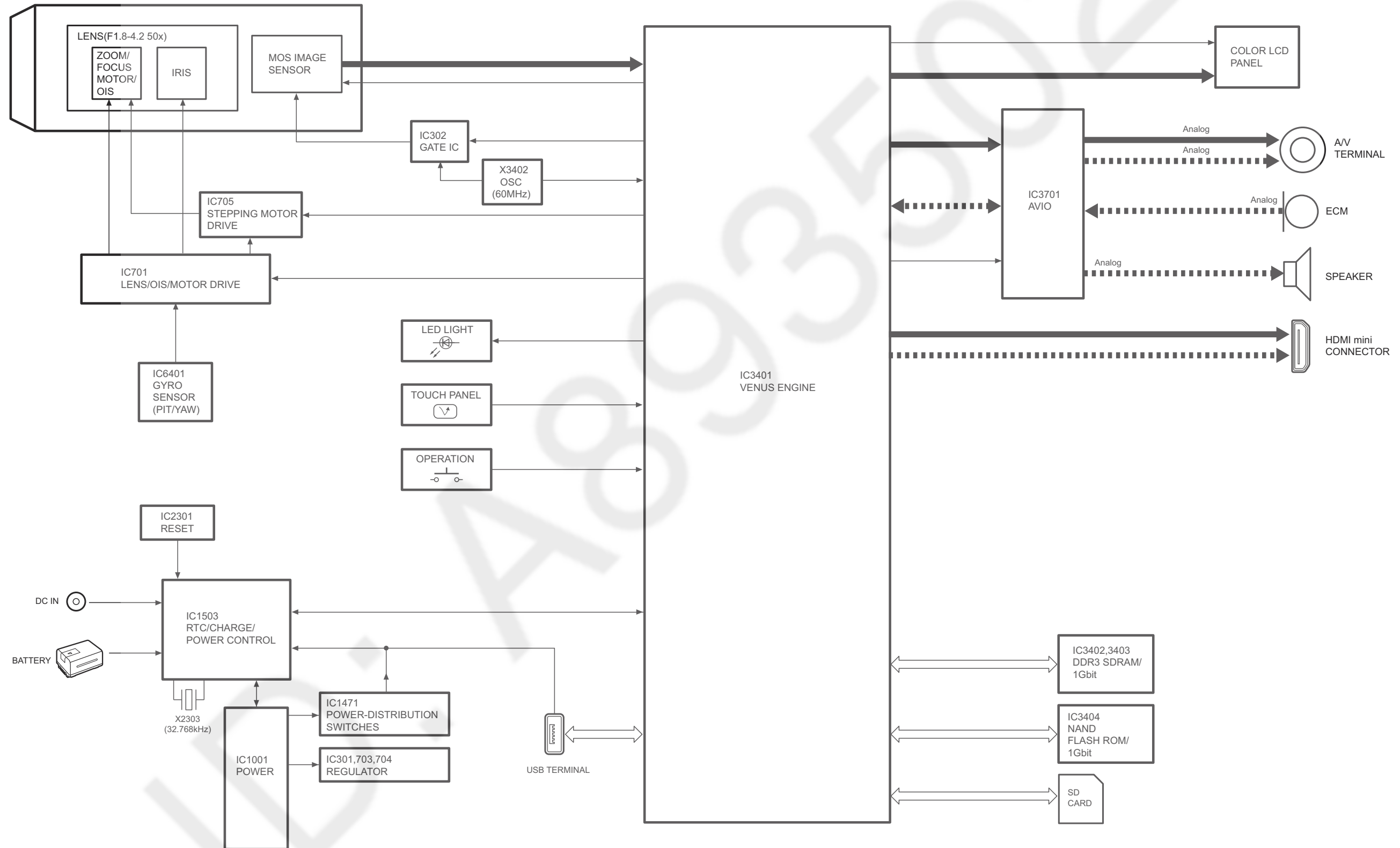

HC-V180 OVERALL BLOCK DIAGRAM

11.2. Camera/System Control Circuit Block Diagram

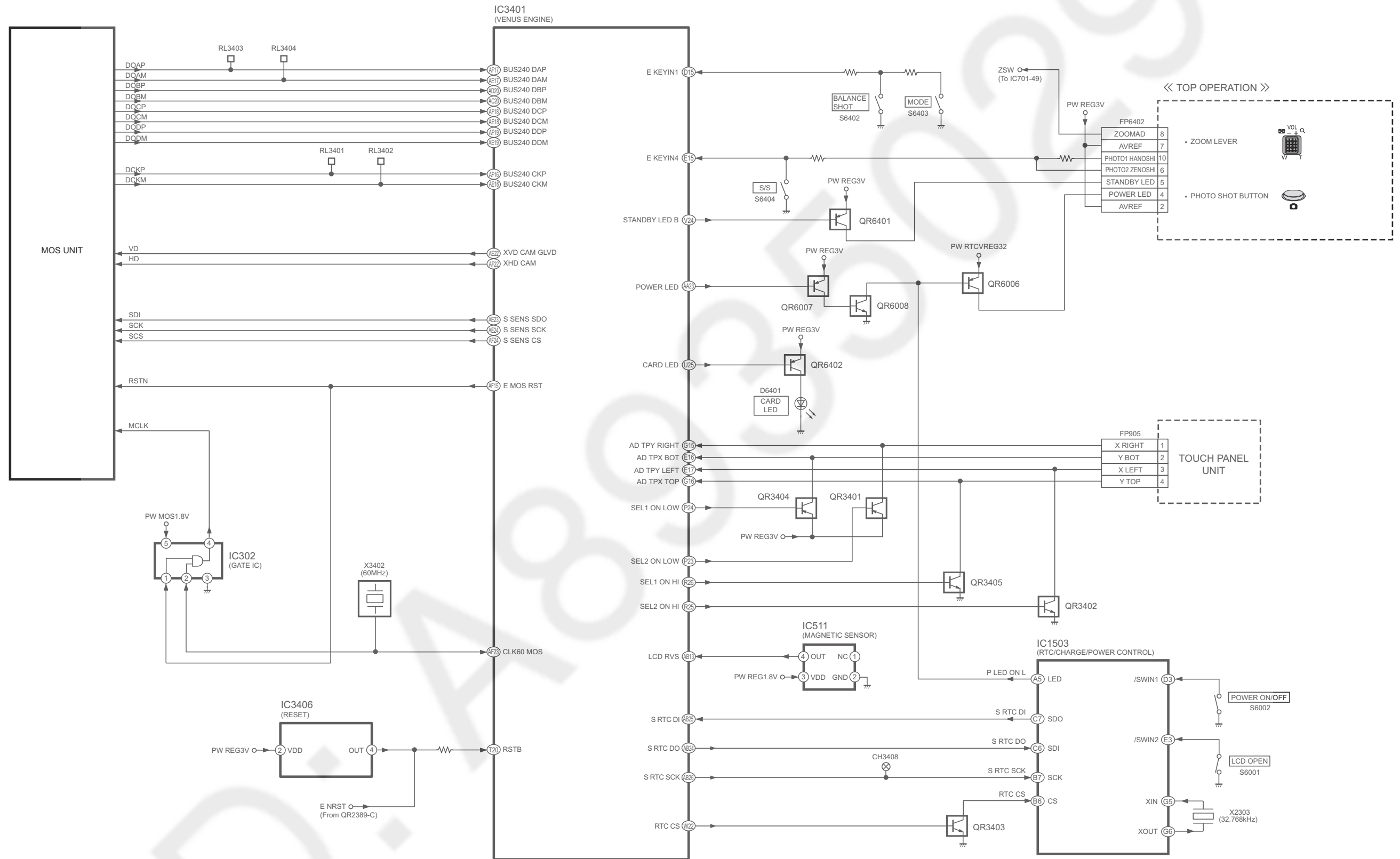

HC-V180 CAMERA/SYSTEM CONTROL CIRCUIT BLOCK DIAGRAM

11.3. Video/Audio Signal Process(1) Circuit Block Diagram

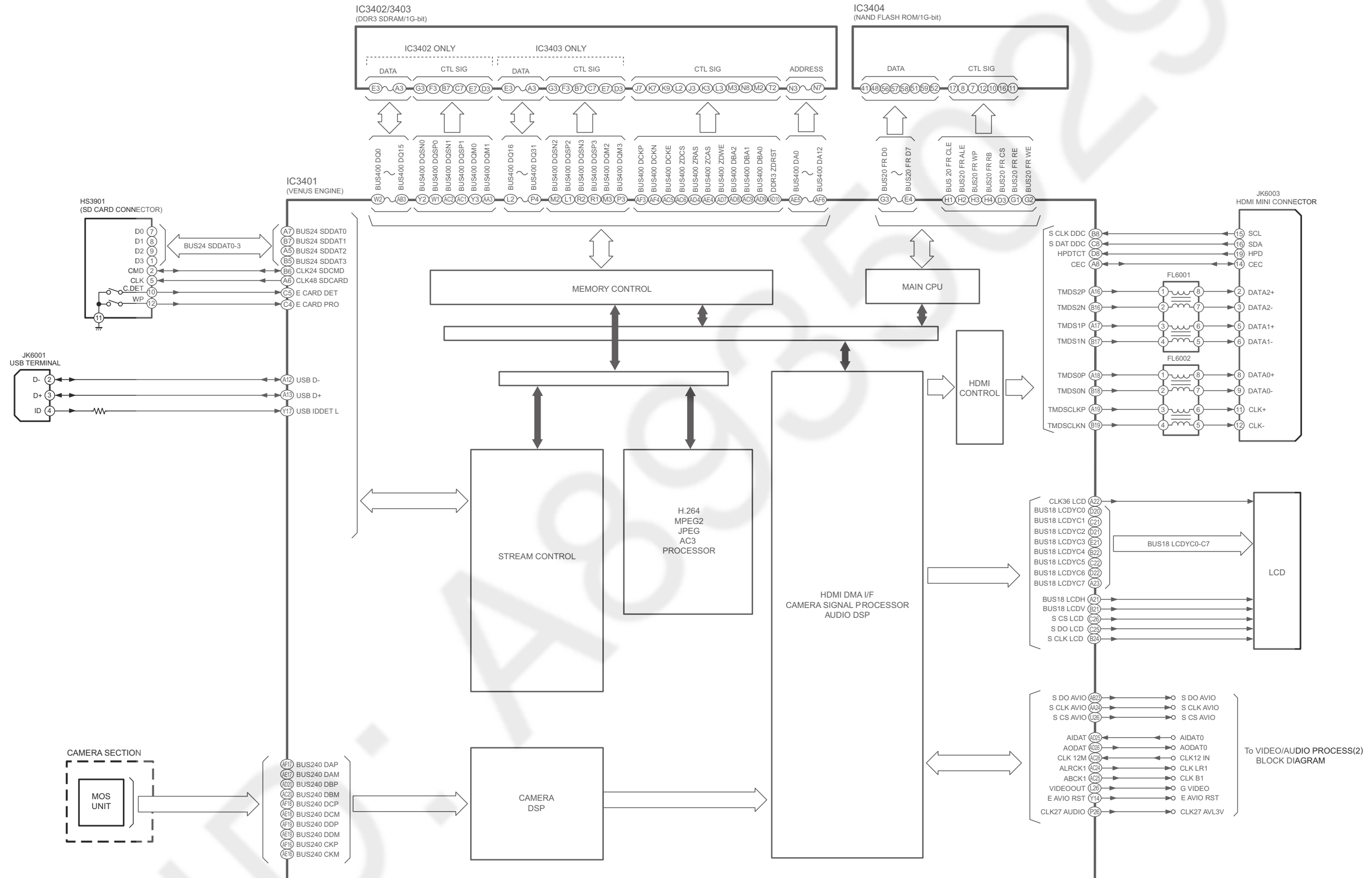

HC-V180 VIDEO/AUDIO PROCESS(1) CIRCUIT BLOCK DIAGRAM

11.4. Video/Audio Signal Process(2) Circuit Block Diagram

To VIDEO/AUDIO PROCESS(1) BLOCK DIAGRAM

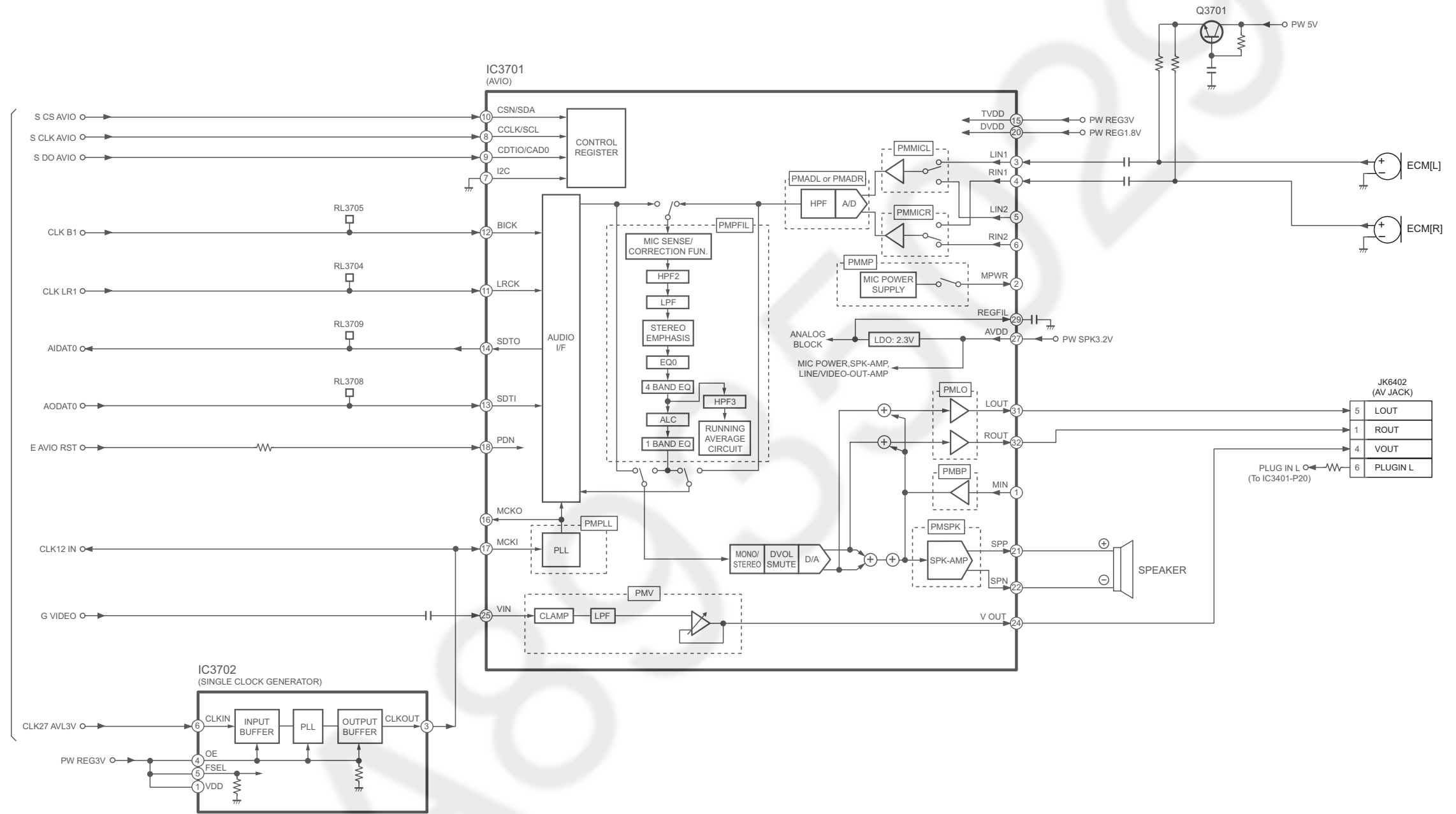

11.5. Lens Drive Circuit Block Diagram

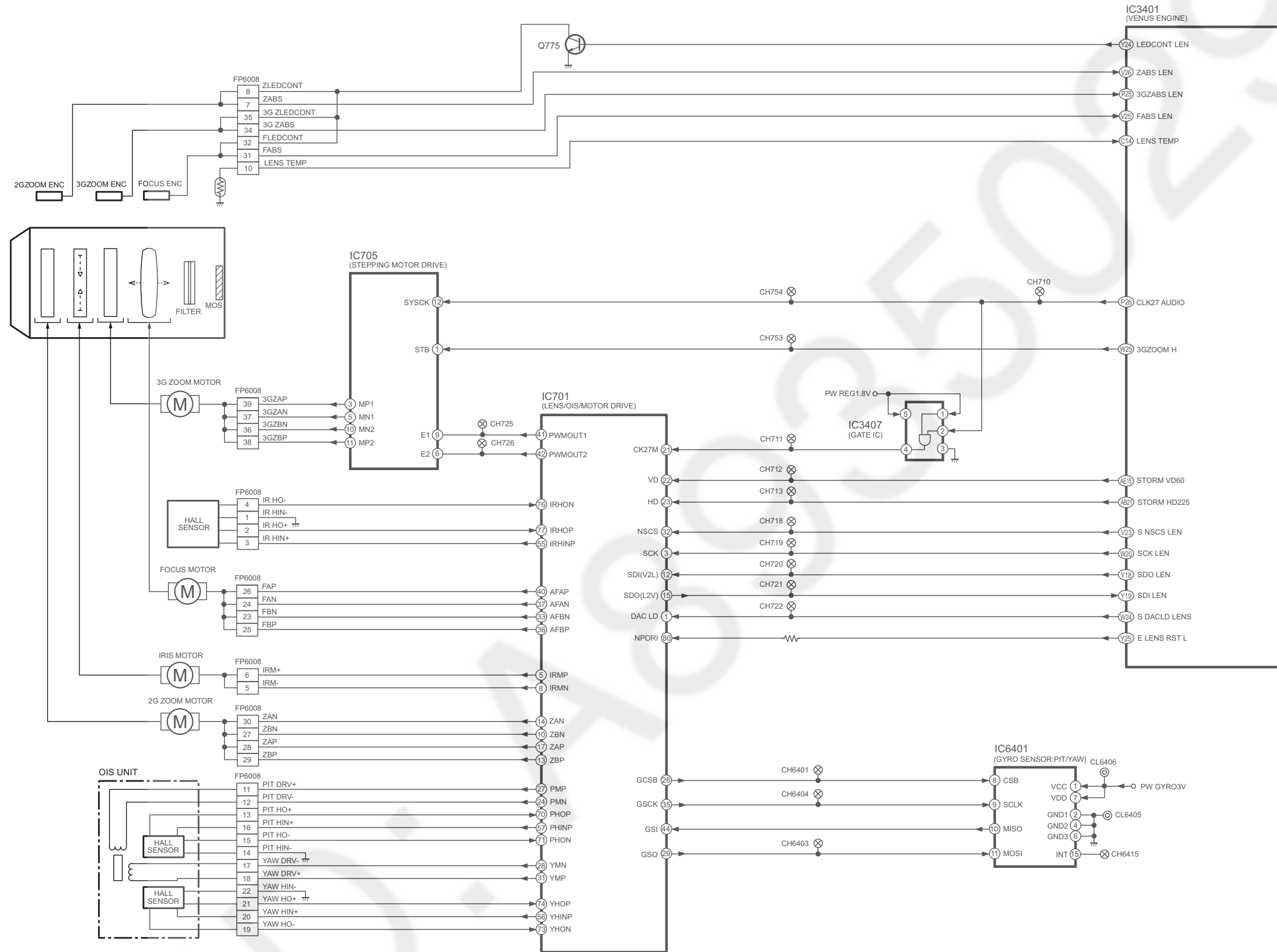

HC-V180 LENS DRIVE CIRCUIT BLOCK DIAGRAM

11.6. Power Supply Circuit Block Diagram

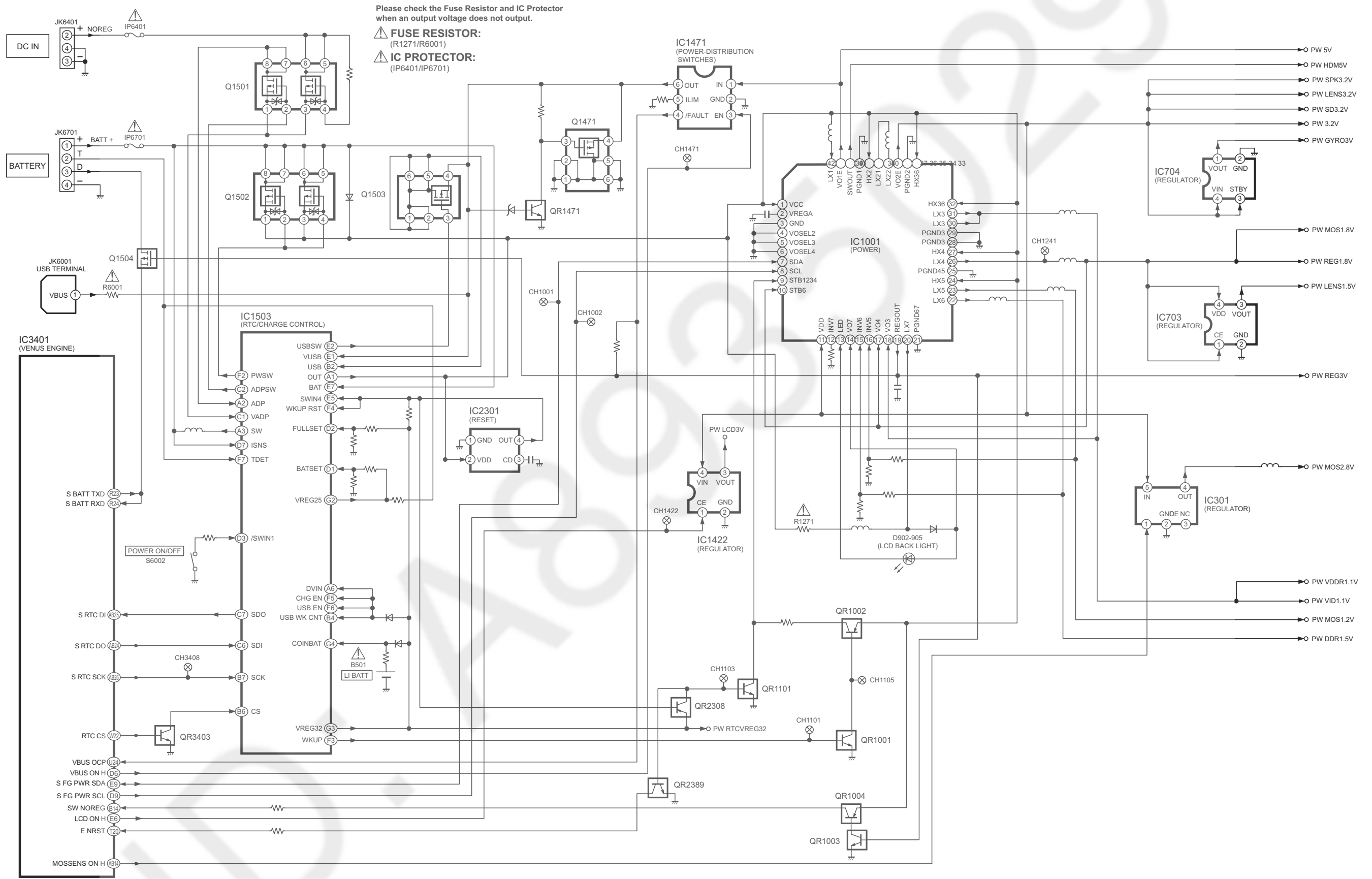

HC-V180 POWER SUPPLY CIRCUIT BLOCK DIAGRAM

13 Schematic Diagram

Please click the radio button for “Diagrams II / Parts List” on the menu bar in XML Service Manual.
If you want to print, please click the icon button for “Print” on the icon bar and select the item.

14 Printed Circuit Board

Please click the radio button for “Diagrams II / Parts List” on the menu bar in XML Service Manual.

If you want to print, please click the icon button for “Print” on the icon bar and select the item.

15 Exploded View and Replacement Parts List

Please click the radio button for “Diagrams II / Parts List” on the menu bar in XML Service Manual.

If you want to print, please click the icon button for “Print” on the icon bar and select the item.