

Service Manual

Digital Video Camera/Recorder

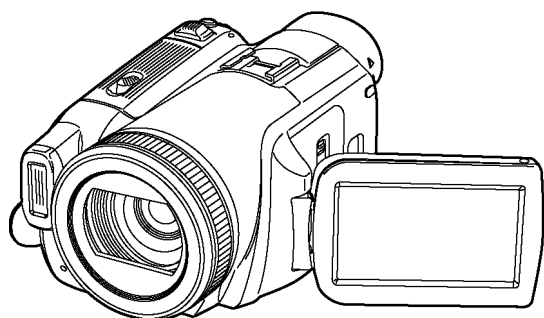

- NV-GS500EG
- NV-GS500E
- NV-GS500EB
- NV-GS500EP
- NV-GS500EE
- NV-GS500GC
- NV-GS500GN
- NV-GS500SG
- NV-GS500GCT
- NV-GS500PL
- NV-GS500GT
- NV-GS508GK

VOL.1

A-MECHANISM

Colour

(S).....Silver Type

TABLE OF CONTENTS

	PAGE	PAGE
1 Safety Precaution	3	
1.1. General Guidelines	3	
2 Warning	4	
2.1. Caution for AC Cord (VJA0940 type)	4	
2.2. Prevention of Electro Static Discharge (ESD) to Electrostatically Sensitive (ES) Devices	5	
2.3. Handling the Lead-free Solder	6	
2.4. How to Replace the Lithium Battery (PROCEDURE)	7	
3 Service Navigation	8	
3.1. Service Information	8	
3.2. Service Caution	8	
4 Specifications	9	
5 Location of Controls and Components	10	
6 Service Mode	12	
6.1. Error Display	12	
6.2. Service Menu	13	
7 Service Fixture & Tools	15	
7.1. Service Tools and Equipment	15	
8 Disassembly and Assembly Instructions	16	
8.1. Disassembly Flow Chart	16	
8.2. P.C.B. Layout	16	
8.3. Disassembly Procedures	17	
8.4. Disassembly Procedures Mecha. Unit	27	
8.5. Disassembly Procedures of Camera Lens Unit	31	
9 Measurements and Adjustments	32	
9.1. Service Positions	32	
9.2. Location for Connectors of the Main P.C.B. & Sub P.C.B.	34	
9.3. Electrical Adjustment Procedures	36	
9.4. Mechanical Adjustment Procedures	40	
10 Maintenance	42	
10.1. Cleaning Lens, Viewfinder and LCD Panel	42	

1 Safety Precaution

1.1. General Guidelines

1. IMPORTANT SAFETY NOTICE

There are special components used in this equipment which are important for safety. These parts are marked by \triangle in the Schematic Diagrams, Circuit Board Layout, Exploded Views and Replacement Parts List. It is essential that these critical parts should be replaced with manufacturer's specified parts to prevent X-RADIATION, shock fire, or other hazards. Do not modify the original design without permission of manufacturer.

2. An Isolation Transformer should always be used during the servicing of AC Adaptor whose chassis is not isolated from the AC power line. Use a transformer of adequate power rating as this protects the technician from accidents resulting in personal injury from electrical shocks. It will also protect AC Adaptor from being damaged by accidental shorting that may occur during servicing.
3. When servicing, observe the original lead dress. If a short circuit is found, replace all parts which have been overheated or damaged by the short circuit.
4. After servicing, see to it that all the protective devices such as insulation barriers, insulation papers shields are properly installed.
5. After servicing, make the following leakage current checks to prevent the customer from being exposed to shock hazards.

1.1.1. Leakage current cold check

1. Unplug the AC cord and connect a jumper between the two prongs on the plug.
2. Measure the resistance value, with an ohmmeter, between the jumpered AC plug and each exposed metallic cabinet part on the equipment such as screwheads, connectors, control shafts, etc. When the exposed metallic part has a return path to the chassis, the reading should be between $1M\Omega$ and $5.2M\Omega$. When the exposed metal does not have a return path to the chassis, the reading must be infinity.

1.1.2. Leakage current hot check (See Figure 1)

1. Plug the AC cord directly into the AC outlet. Do not use an isolation transformer for this check.
2. Connect **A** to exposed metallic part on the set. And connect **B** to a good earth ground, as shown in Figure 1.
3. Use an AC voltmeter, with $1\text{ k}\Omega/\text{V}$ or more sensitivity, to measure the potential across the resistor.
4. Check each exposed metallic part, and measure the voltage at each point.
5. Reverse the AC plug in the AC outlet and repeat each of the above measurements.
6. The potential at any point should not exceed 0.75 V RMS . A leakage current tester (Simpson Model 229 or equivalent) may be used to make the hot checks, leakage current must not exceed $1/2\text{ mA}$. In case a measurement is outside of the limits specified, there is a possibility of a shock hazard, and the equipment should be repaired and rechecked before it is returned to the customer.

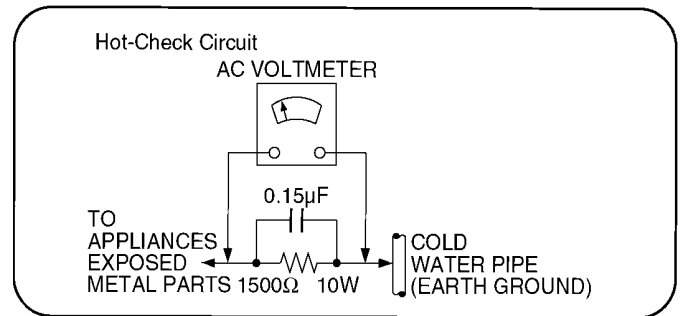

Figure 1

2 Warning

2.1. Caution for AC Cord (VJA0940 type)

2.1.1. Information for your safety

IMPORTANT

Your attention is drawn to the fact that recording of pre-recorded tapes or discs or other published or broadcast material may infringe copyright laws.

WARNING

To reduce the risk of fire or shock hazard, do not expose this equipment to rain or moisture.

CAUTION

To reduce the risk of fire or shock hazard and annoying interference, use the recommended accessories only.

FOR YOUR SAFETY

DO NOT REMOVE THE OUTER COVER

To prevent electric shock, do not remove the cover. No user serviceable parts inside. Refer servicing to qualified service personnel.

2.1.2. Caution for AC mains lead

For your safety, please read the following text carefully.

This appliance is supplied with a moulded three-pin mains plug for your safety and convenience.

A 5-ampere fuse is fitted in this plug.

Should the fuse need to be replaced please ensure that the replacement fuse has a rating of 5 amperes and it is approved by ASTA or BSI to BS1362

Check for the ASRA mark or the BSI mark on the body of the fuse.



If the plug contains a removable fuse cover you must ensure that it is refitted when the fuse is replaced.

If you lose the fuse cover, the plug must not be used until a replacement cover is obtained.

A replacement fuse cover can be purchased from your local Panasonic Dealer.

If the fitted moulded plug is unsuitable for the socket outlet in your home then the fuse should be removed and the plug cut off and disposed of safely.

There is a danger of severe electrical shock if the cut off plug is inserted into any 13-ampere socket.

If a new plug is to be fitted please observe the wiring code as shown below.

If in any doubt, please consult a qualified electrician.

2.1.2.1. Important

The wires in this mains lead are coloured in accordance with the following code:

Blue	Neutral
Brown	Live

As the colours of the wires in the mains lead of this appliance may not correspond with the coloured markings identifying the terminals in your plug, proceed as follows:

The wire which is coloured BLUE must be connected to the terminal in the plug which is marked with the letter N or coloured BLACK.

The wire which is coloured BROWN must be connected to the terminal in the plug which is marked with the letter L or coloured RED.

Under no circumstances should either of these wires be connected to the earth terminal of the three pin plug, marked with the letter E or the Earth Symbol.

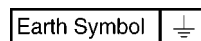

2.1.2.2. Before use

remove the Connector Cover as follows.

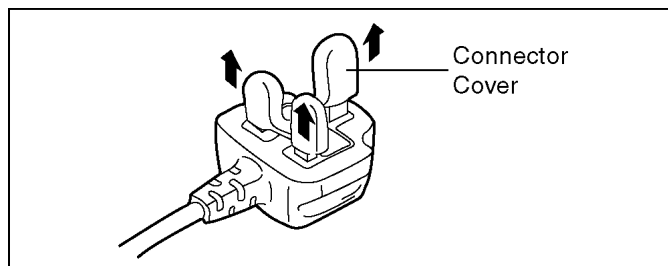

2.1.2.3. How to replace the Fuse

1. Remove the Fuse Cover with a screwdriver.

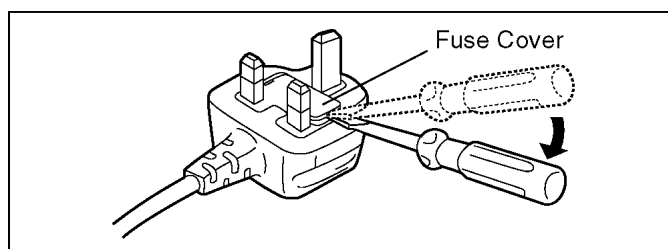

2. Replace the fuse and attach the Fuse cover.

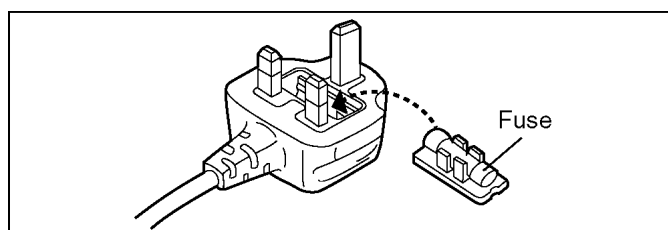

2.2. Prevention of Electro Static Discharge (ESD) to Electrostatically Sensitive (ES) Devices

Some semiconductor (solid state) devices can be damaged easily by static electricity. Such components commonly are called Electrostatically Sensitive (ES) Devices. Examples of typical ES devices are integrated circuits and some field-effect transistors and semiconductor **chip** components. The following techniques should be used to help reduce the incidence of component damage caused by electro static discharge (ESD).

1. Immediately before handling any semiconductor component or semiconductor-equipped assembly, drain off any ESD on your body by touching a known earth ground. Alternatively, obtain and wear a commercially available discharging ESD wrist strap, which should be removed for potential shock reasons prior to applying power to the unit under test.
2. After removing an electrical assembly equipped with ES devices, place the assembly on a conductive surface such as aluminum foil, to prevent electrostatic charge buildup or exposure of the assembly.
3. Use only a grounded-tip soldering iron to solder or unsolder ES devices.
4. Use only an antistatic solder removal device. Some solder removal devices not classified as **antistatic (ESD protected)** can generate electrical charge sufficient to damage ES devices.
5. Do not use freon-propelled chemicals. These can generate electrical charges sufficient to damage ES devices.
6. Do not remove a replacement ES device from its protective package until immediately before you are ready to install it. (Most replacement ES devices are packaged with leads electrically shorted together by conductive foam, aluminum foil or comparable conductive material).
7. Immediately before removing the protective material from the leads of a replacement ES device, touch the protective material to the chassis or circuit assembly into which the device will be installed.

CAUTION:

Be sure no power is applied to the chassis or circuit, and observe all other safety precautions.

8. Minimize bodily motions when handling unpackaged replacement ES devices. (Otherwise harmless motion such as the brushing together of your clothes fabric or the lifting of your foot from a carpeted floor can generate static electricity (ESD) sufficient to damage an ES device).

IMPORTANT SAFETY NOTICE

There are special components used in this equipment which are important for safety. These parts are marked by \triangle in the schematic diagrams, Exploded Views and replacement parts list. It is essential that these critical parts should be replaced with manufacturer's specified parts to prevent shock, fire, or other hazards. Do not modify the original design without permission of manufacturer.

2.3. Handling the Lead-free Solder

2.3.1. General description about Lead Free Solder (PbF)

The lead free solder has been used in the mounting process of all electrical components on the printed circuit boards used for this equipment in considering the globally environmental conservation.

The normal solder is the alloy of tin (Sn) and lead (Pb). On the other hand, the lead free solder is the alloy mainly consists of tin (Sn), silver (Ag) and Copper (Cu), and the melting point of the lead free solder is higher approx.30 degrees C (86 °F) more than that of the normal solder.

Definition of PCB Lead Free Solder being used

The letter of PbF is printed either foil side or components side on the PCB using the lead free solder. (See right figure)	PbF
--	------------

Service caution for repair work using Lead Free Solder (PbF)

- The lead free solder has to be used when repairing the equipment for which the lead free solder is used.
- (Definition: The letter of **PbF** is printed on the PCB using the lead free solder.)
- To put lead free solder, it should be well molten and mixed with the original lead free solder.
- Remove the remaining lead free solder on the PCB cleanly for soldering of the new IC.
- Since the melting point of the lead free solder is higher than that of the normal lead solder, it takes the longer time to melt the lead free solder.
- Use the soldering iron (more than 70W) equipped with the temperature control after setting the temperature at 350±30 degrees C (662±86 °F).

Recommended Lead Free Solder (Service Parts Route.)

- The following 3 types of lead free solder are available through the service parts route.
 - RFKZ03D01K------(0.3mm 100g Reel)
 - RFKZ06D01K------(0.6mm 100g Reel)
 - RFKZ10D01K------(1.0mm 100g Reel)

Note

* Ingredient: tin (Sn) 96.5%, silver (Ag) 3.0%, Copper (Cu) 0.5%, Cobalt (Co) / Germanium (Ge) 0.1 to 0.3%

2.4. How to Replace the Lithium Battery (PROCEDURE)

1. Remove the Side (L) P.C.B.. (Refer to Disassembly Procedures.)
2. Unsolder the Lithium Battery **ML-621S/F9D** and then replace the new one. (See Figure B1.)
3. Danger of explosion if battery is incorrectly replaced. Replace only with the same or equivalent type.

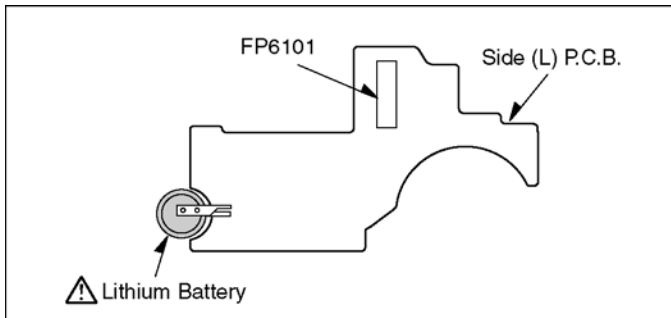

CAUTION

The battery used in this device may present a risk of fire or chemical burn if mistreated.
Do not recharge, disassemble, heat above 100°C (212°F), or incinerate.
Replace battery with Panasonic part number ML-621S/F9D only.
Use of another battery may present a risk of fire or explosion.
Dispose of used battery promptly.
Keep away from children.
Do not disassemble and do not dispose of in fire.

Fig. B1

Note:

The lithium battery is a critical component. (Type No.: ML-621S/F9D)
It must never be subjected to excessive heat or discharge.
It must therefore only be fitted in equipment designed specifically for its use.
Replacement batteries must be of the same type and manufacture.
They must be fitted in the same manner and location as the original battery, with the correct polarity contacts observed.
Do not attempt to re-charge the old battery or re-use it for any other purpose.
It should be disposed of in waste products destined for burial rather than incineration.

CAUTION

Danger of explosion if battery is incorrectly replaced.
Replace only with the same or equivalent type recommended by the equipment manufacturer.
Discard used batteries according to manufacturer's instructions.

PRECAUTION

Le fait de remplacer incorrectement la pile peut présenter des risques d'explosion.
Remplacer la pile uniquement par une pile identique ou de type équivalent recommandée par le fabricant. Se débarrasser des piles usagées conformément aux instructions du fabricant.

VORSICHT

Bei einer falsch eingesetzten Batterie besteht Explosionsgefahr. Nur mit einer vom Hersteller empfohlenen Batterie vom gleichen Typ ersetzen.
Verbrauchte Batterien beim Fachhändler oder einer Sammelstelle für Sonderstoffe abliefern.

VARNING

Explosionsfara vid felaktigt batteribyte.
Använd samma batterityp eller en ekvivalent typ som rekommenderas av apparatillverkaren.
Kassera använt batteri enligt fabrikantens instruktion.

ADVARSEL!

Lithiumbatteri-Eksplosionsfare ved fejlagtig håndtering.
Udskiftning må kun ske med batteri af samme fabrikat og type.
Levér det brugte batteri tilbage til leverandøren.

VAROITUS

Paristo voi räjähtää, jos se on virheellisesti asennettu.
Vaihda paristo ainoastaan laitevalmistajan suosittelemaan tyyppiin.
Hävitätä käytetty paristo valmistajan ohjeiden mukaisesti.

3 Service Navigation

3.1. Service Information

This service manual contains technical information which will allow service personnel's to understand and service this model. Please place orders using the parts list and not the drawing reference numbers.

If the circuit is changed or modified, this information will be followed by supplement service manual to be filed with original service manual.

Note 1:

These movie camera uses AC Adaptor VSK0644.

Note 2:

- 1) This service manual does not contain the following information, because of the impossibility of sevicng at component level.
 1. Schematic Diagram, Block Diagram and P.C.B. layout of Main P.C.B./Sub P.C.B.
 2. Parts List for individual parts of Main P.C.B./Sub P.C.B.

2) The following category are recycle module part. Please send them to Central Repair Center.

*Main P.C.B.

(VEP03G87K: NV-GS500EG/E/EB/EP, VEP03G87L: NV-GS500EE/GC/GN/SG, VEP03G87M: NV-GS508GK, VEP03G87Q: NV-GS500GT, VEP03G87R: NV-GS500PL, VEP03G87U: NV-GS500GCT)

*Sub P.C.B.

(VEP23646B: NV-GS500EG/E/EB/EP/EE/GC/GN/SG/GCT, GS508GK, VEP23646C: NV-GS500PL/GT)

When a part replacement is required for repairing each Main P.C.B. and/or Sub P.C.B., replace the assembly parts. (Main P.C.B. and/or Sub P.C.B.)

The following circuits are contained in Main P.C.B.

1. Main Connection Circuit
2. AVIO Circuit
3. Video Circuit
4. Power Circuit
5. Control Circuit

The following circuit is contained in Sub P.C.B..

1. Sub Connection Circuit
2. Camera Circuit
3. Lens Drive Circuit

3.2. Service Caution

3.2.1. How to Discharge the Capacitor on the Front P.C.B.

Remove the Front P.C.B.. (Refer to Disassembly Procedures.)

CAUTION

Be sure to discharge the capacitor on Front P.C.B. before disassembling.

CAUTION

Be careful of the high voltage circuit on Front P.C.B. when servicing.

Method:

1. Prepare the 2 Resistors (ERG2SJ221:220 ohm/2w) for discharge.

Note:

- Above 2 Resistors may be substituted with equivalent type.
2. Make short circuit using 2 Resistors between C7004(+) and C7004(-) for 3 seconds as follows.
3. After discharging, confirm that the capacitor voltage is sufficiently lowered using a voltmeter

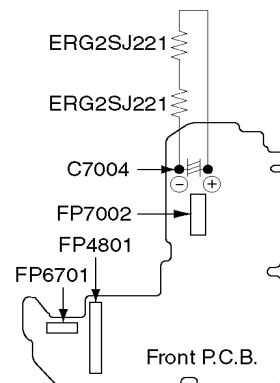

3.2.2. EEPROM data for spare parts of the Main P.C.B.

When the Main P.C.B. is replaced, the fixed and average data must be changed by Tatsujin kit according to the Movie Camera's suffix.

Then, confirm and/or adjust the VTR and Camera section one by one.

4 Specifications

Digital Video Camera / Recorder

ITEM	SPECIFICATION	ITEM	SPECIFICATION
POWER	Source: DC 7.9 / 7.2 V Consumption: Recording 4.2 W (When using Viewfinder) 4.5 W (When using LCD Monitor)	STANDARD ILLUMINATION	1,400 lx
		MINIMUM REQUIRED ILLUMINATION	2 lx (Colour Night View Mode)
RECORDING FORMAT	Mini DV (Consumer-use Digital Video SD Format)	USB	Card reader/writer function, USB 2.0 compliant (Hi-Speed) No copyright protection support Pict Bridge-Compliant
TAPE USED	6.35 mm digital video tape		DIGITAL INTERFACE
RECORDING / PLAYBACK TIME	SP mode: 80 min. with DVM80 LP mode: 120 min. with DVM80	VIDEO FLASH	GN 5.3
CAMERA	Filter Diameter: 43.0 mm	MICROPHONE	Stereo (with a zoom function)
	Zoom: 12:1 Power Zoom	SPEAKER	1 round speaker ϕ 20 mm
	Monitor: 2.7-inch LCD	OPERATING TEMPERATURE	0 °C - 40 °C
	Lens: Auto Iris, F1.6 to F2.8, Focal Length; 3.3 - 39.6 mm Macro (Full Range AF)	OPERATING HUMIDITY	10 % - 80 %
	Image Sensor: 1/4.7-inch 3CCD Image Sensor Viewfinder: Colour Electronic Viewfinder		
WEB CAMERA	Compression: Motion JPEG	WEIGHT	Approx. 570 g (without supplide Battery, DV cassette and lens cap) Approx. 670 g (with supplide Battery, DV cassette and lens cap)
	Image Size: 320 × 240 pixels (QVGA) Frame Rate: Approx. 6fps		DIMENSIONS
VIDEO	Recording System: Digital Component Television System: CCIR; 625 Lines, 50 Fields PAL Colour Signal (Except NV-GS500PL/GT) EIA Standard: 525 Lines, 60 Fields NTSC Colour Signal (NV-GS500PL/GT)	STANDARD ACCESSORIES	1 pc. AC Adaptor 1 pc. Battery Pack Unit 1 pc. DC Cable 1 pc. AC Cord (Except NV-GS500GC/SG) 2 pcs. AC Cord (NV-GS500GC/SG) 1 pc. AV Multi Cable 1 pc. Remote Controller 1 pc. Bottom-type Battery 1 pc. Head Cleaner (NV-GS500EE/GC/GN/GCT/SG, GS508GK) 1 pc. Shoulder Belt 1 pc. Universal Remote Controller
	Video Output Level: 1.0 Vp-p 75 ohm (AV Multi Jack) S-Video Output Level: Y Output; 1.0 Vp-p 75 ohm (AV Multi Jack) C Output; 0.3 Vp-p 75 ohm (Except NV-GS500PL/GT) C Output; 0.286 Vp-p 75 ohm (NV-GS500PL/GT)		SOLDER
AUDIO	Recording System: PCM Digital Recording 16 bit (48 kHz/2 ch) 12 bit (32 kHz/4 ch)		
	Audio Output Level: 316 mV, 600 ohm (AV Multi Jack) Mic Input: Mic sensitivity -50dB(0dB=1V/Pa,1kHz) (Stereo Mini Jack)		
CARD MEMORY FUNCTIONS	Recording Media: SD Memory Card Still Picture Recording File Format: JPEG (Design rule for Camera File system, based on Exif 2.2 standard), DPOF corresponding Still Image Size: Mega-pixel Recording; 2288 × 1728 (4.0 million pixels, 4:3 Mode) 2288 × 1288 (3.0 million pixels, 16:9 Mode) 1600 × 1200 (2.0 million pixels, 4:3 Mode) 1280 × 960 (1.0 million pixels, 4:3 Mode) VGA Recording; 640 × 360 (16:9 Mode) 640 × 480 (4:3 Mode)		

Weight and dimensions are approximate values.
Specifications may change without prior notice.

5 Location of Controls and Components

Followings are the Location of Controls and Components for NV-GS500EB as a sample.

For other models, refer to each Operatin Instructions.

Parts identification and handling

■ Camera

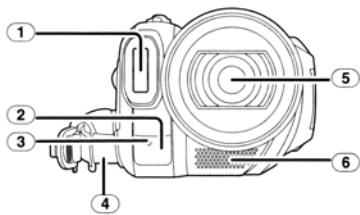

- ① Built-in video flash
- ② White balance sensor
Remote control sensor
- ③ Recording lamp
- ④ Grip belt
(One-touch free-style grip belt)
- ⑤ Lens (LEICA DICOMAR)
- ⑥ Microphone (built-in, stereo)

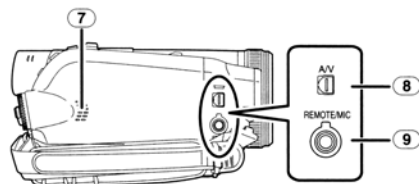

- ⑦ Speaker
- ⑧ Audio-video/S-Video output terminal [A/V]
 - Use the supplied Multi cable only, otherwise audio may not be played back normally.
- ⑨ Terminal for free style remote control [REMOTE]
Microphone terminal [MIC]
 - A compatible plug-in powered microphone can be used as an external microphone.
 - When the movie camera is connected with AC adaptor, sometimes noise may be heard depending on microphone type. In that case, please switch to battery for power supply and noise will stop.

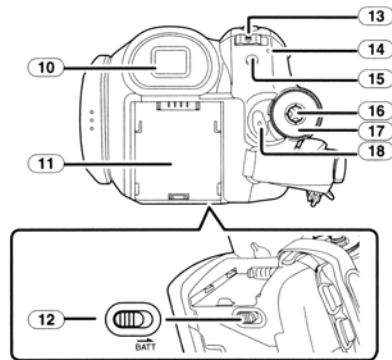

⑩ Viewfinder

Due to limitations in LCD production technology, there may be some tiny bright or dark spots on the Viewfinder screen. However, this is not a malfunction and does not affect the recorded picture.

- ⑪ Battery holder
- ⑫ Battery release lever [BATT]
- ⑬ Power switch [OFF/ON]
- ⑭ Status indicator
- ⑮ Menu button [MENU]
- ⑯ Joystick
- ⑰ Mode dial
- ⑱ Recording start/stop button

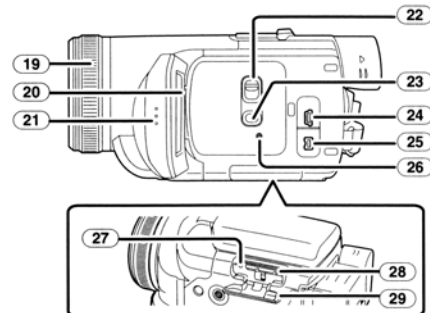

- ⑲ Focus ring
- ⑳ LCD monitor

Due to limitations in LCD production technology, there may be some tiny bright or dark spots on the LCD monitor screen. However, this is not a malfunction and does not affect the recorded picture.

- 21 LCD monitor open part [OPEN]
- 22 Mode select switch [AUTO/MANUAL/FOCUS]
- 23 Power LCD button [POWER LCD]
- 24 USB terminal [-<-]
- 25 DV input/output terminal [DV]
- 26 Reset button [RESET]
- 27 Card access lamp
- 28 Card slot
- 29 Card slot cover

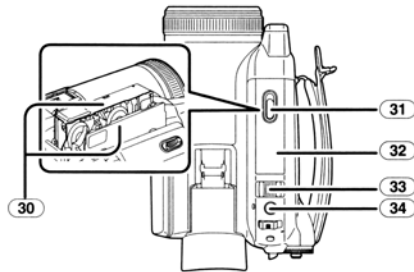

- 30 Cassette holder
- 31 Cassette eject lever [OPEN/EJECT]
- 32 Cassette cover
- 33 Zoom lever [W/T]
Volume lever [-<-/VOL+]
- 34 Photoshot button [PHOTO SHOT]

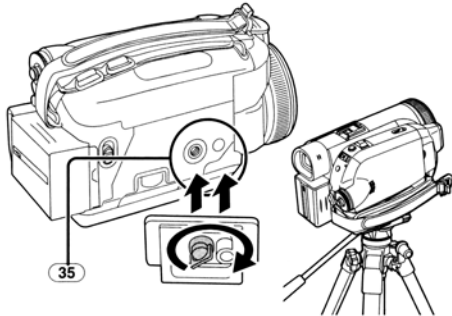

- 35 Tripod receptacle
- This is a hole for attaching the camera to optional tripod/VW-CT45E. (Please carefully read the operating instructions for how to attach the tripod to the camera.)
- When the tripod is used, operate the camera from the free style remote control for convenience. (When not using the remote control, attach the clip to the grip belt for convenience. When you move with remote control attached to a pocket, etc., take care to avoid falling of the tripod.)
 - You cannot open the card slot cover when the tripod is used. Insert the card first and then attach the tripod.

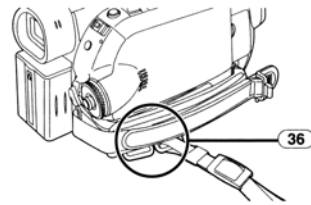

- 36 Shoulder strap fixture
- This is a fixture for attaching the shoulder strap to hang the camera from your neck or shoulder.

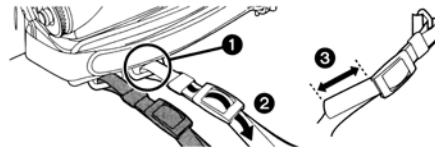

- Put the strap through the fixture 1 and through the stopper 2 so it will not come off. Extend part 3 by at least 2 cm.
- Fit the other end of the belt similarly.

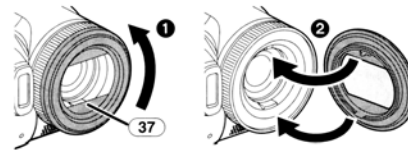

- 37 Lens hood
- In order to remove the lens hood, rotate it counterclockwise 1. In order to fit it, put into slot 2, and then rotate it clockwise.

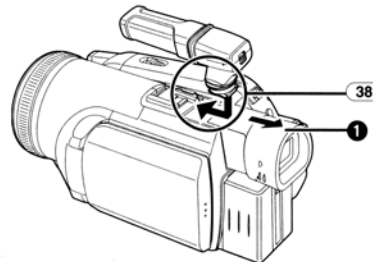

- 38 Smart accessory shoe
- The stereo zoom microphone /VW-VMH3E (optional) or the video DC light/VW-LDH3E (optional) should be mounted here.
- When mounting or removing the accessory, extend the viewfinder (1).
 - When using an accessory for the smart accessory shoe, the power is supplied from this product.

6 Service Mode

6.1. Error Display

PUSH THE RESET SWITCH is displayed automatically on the EVF or the LCD Monitor when an undesirable condition has occurred.

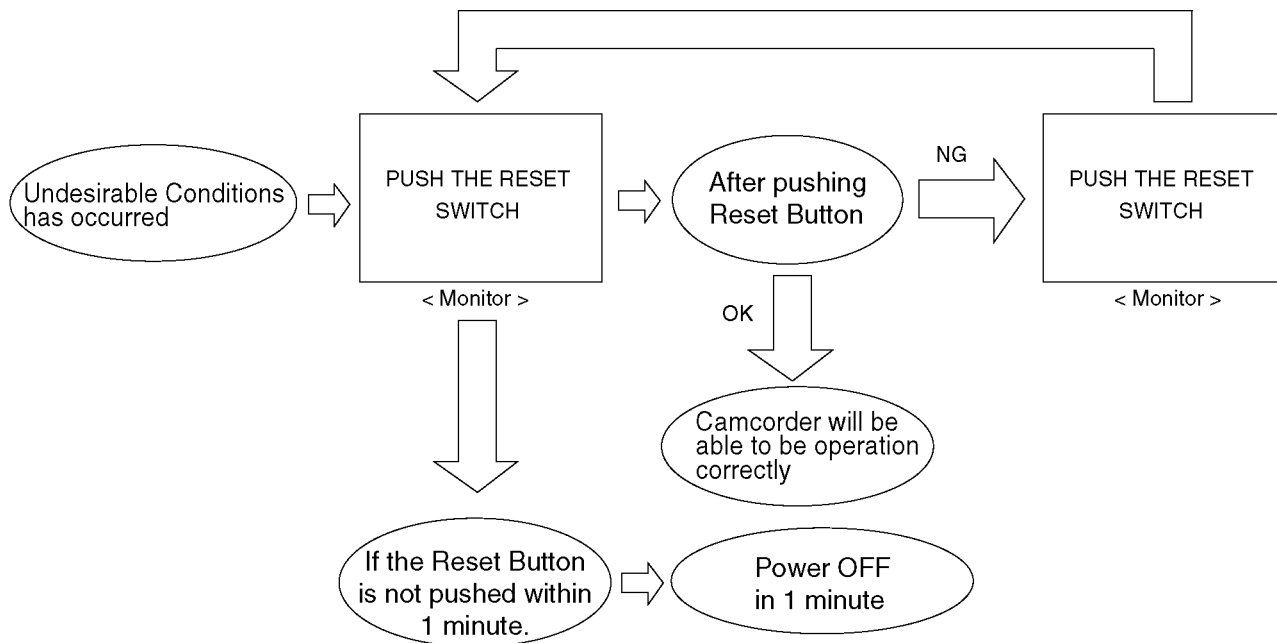

Note:

When "PUSH THE RESET SWITCH" is displayed repeatedly, required.
Check the Error Code which is listed in the Service Menu.

6.2. Service Menu

When abnormal detection contents are confirmed a When I do the following operation automatic diagnosis cord is displayed.

1. Preparation
Remove the card and tape from this machine.
2. Service menu is displayed. (see Fig. S1)
Pushed [PHOTO SHOT] button and [JOYSTICK LEFT ◀] button and [AUTO/MANUAL/FOCUS switch to FOCUS] button simultaneously for 3 seconds.
3. Operating automatic diagnosis cord is displayed.
Item [3] is selected with the [JOYSTICK UP or DOWN ▲/▼] button.
[NO] is selected with the [JOYSTICK RIGHT ▶] button.
[YES] is selected with the [JOYSTICK UP or DOWN ▲/▼] button.
Press the [JOYSTICK CENTER] button.

672C00 010C 22	
1	NO
2	NO
3	NO
4	NO
5	NO
SETUP ENTER EXIT MENU	

ITEM →

Fig. S1

NOTE:

Do not operate items Except for 3 in the Service Menu.

Self diagnosis cord contents are as follows.

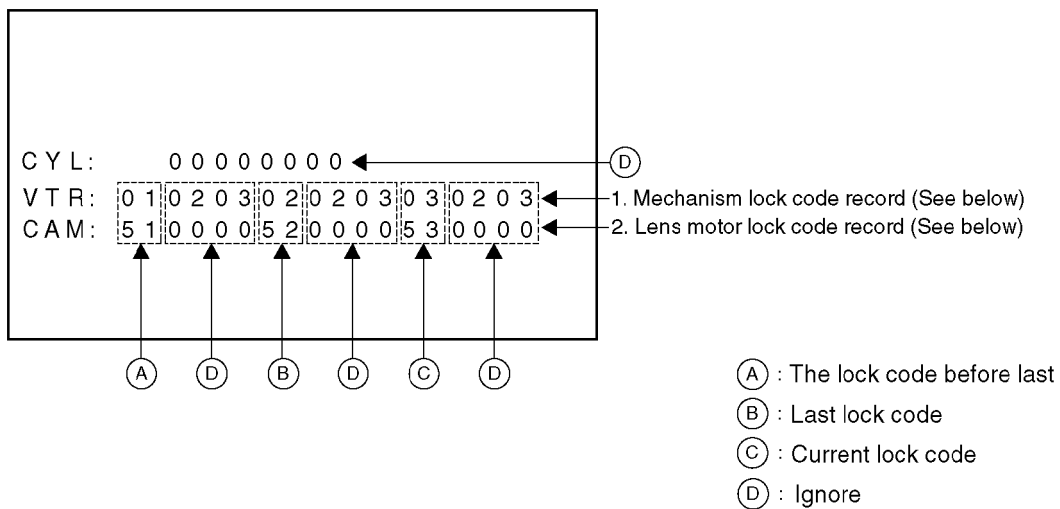

Display contents (self diagnosis cord contents)

Mechanism & Lens motor lock code	
DISPLAY	CONDITION
01	T-REEL LOCK
02	S-REEL LOCK
03	UNLOADING LOCK
04	LOADING LOCK
05	CYLINDER
51	ZOOM MOTOR LOCK
52	FOCUS MOTOR LOCK

Turn off the power supply after confirmation.

Please do the error cord backup record the clear after repair completion.

CLEAR METHOD

If the Card and Tape inserted, take out it before Service Mode operation.

Making the mode dial of This Machine a tape recording mode, push [JOYSTICK LEFT ◀] button and [AUTO/MANUAL/FOCUS switch to FOCUS] button and [RECORDING START/STOP] button simultaneously for 3 seconds.

7 Service Fixture & Tools

7.1. Service Tools and Equipment

Parts Name	Parts No.	Q'ty	Remarks
Step Up Ring	VFK1164TAR43	1	For Collimator 43mm
TATSUJIN PC-Adjustment Program	VF0D2003AV30	1	
Envelope Detection Special Board	VFK1641	1	
Post Driver	VFK1899	1	
Standard Tape	VFM3010EDS	1	
Extension Cable (45pin)	VFK1575C4520	1	FP6902 (Main) - FP4801 (Front)
Extension Cable (45pin)	VFK1575C4520	1	FP701 (Sub) - Lens Unit
Extension Cable (40pin)	VFK1453	1	PS201 (Sub) - Prism Unit
Extension Cable (25pin)	VFK1716	1	FP602 (Side R) - FP902 (Monitor)
Extension Cable (31pin)	VFK1978	1	FP601 (Side R) - FP853 (EVF)
Extension Cable (60pin)	VFK1993	1	PS6901 (Main) - PS6301 (Side R)
Extension Cable (5pin)	VFK1465	1	FP6302 (Side R) - Operation (R) Unit
Extension Cable (10pin)	VFK1440	1	FP6701 (Front) - MF Sensor Unit

8 Disassembly and Assembly Instructions

8.1. Disassembly Frow Chart

This flow chart indicates the disassembly steps the cabinet parts, P.C.B. and Mecha. Unit in order to access to be serviced. When reinstalling, perform the steps in the reverse order.

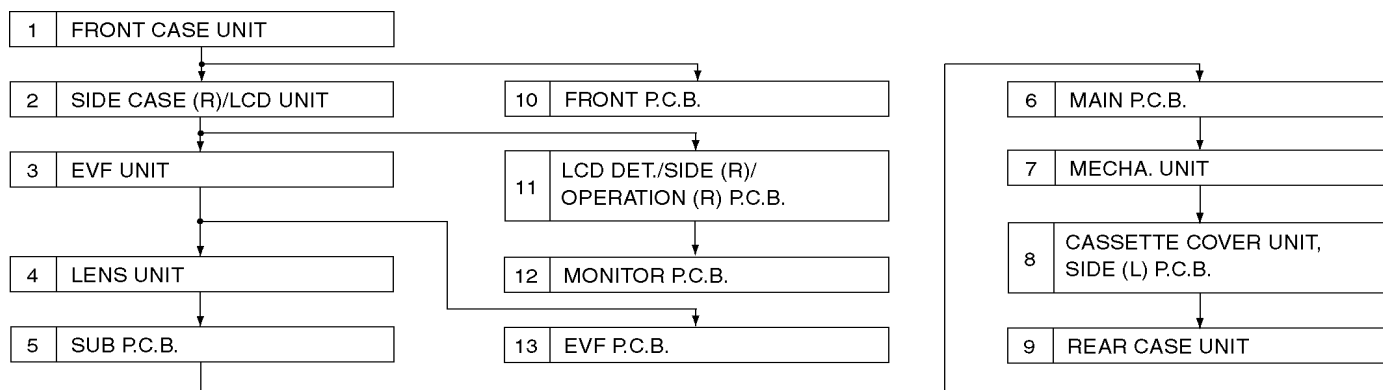

8.2. P.C.B. Layout

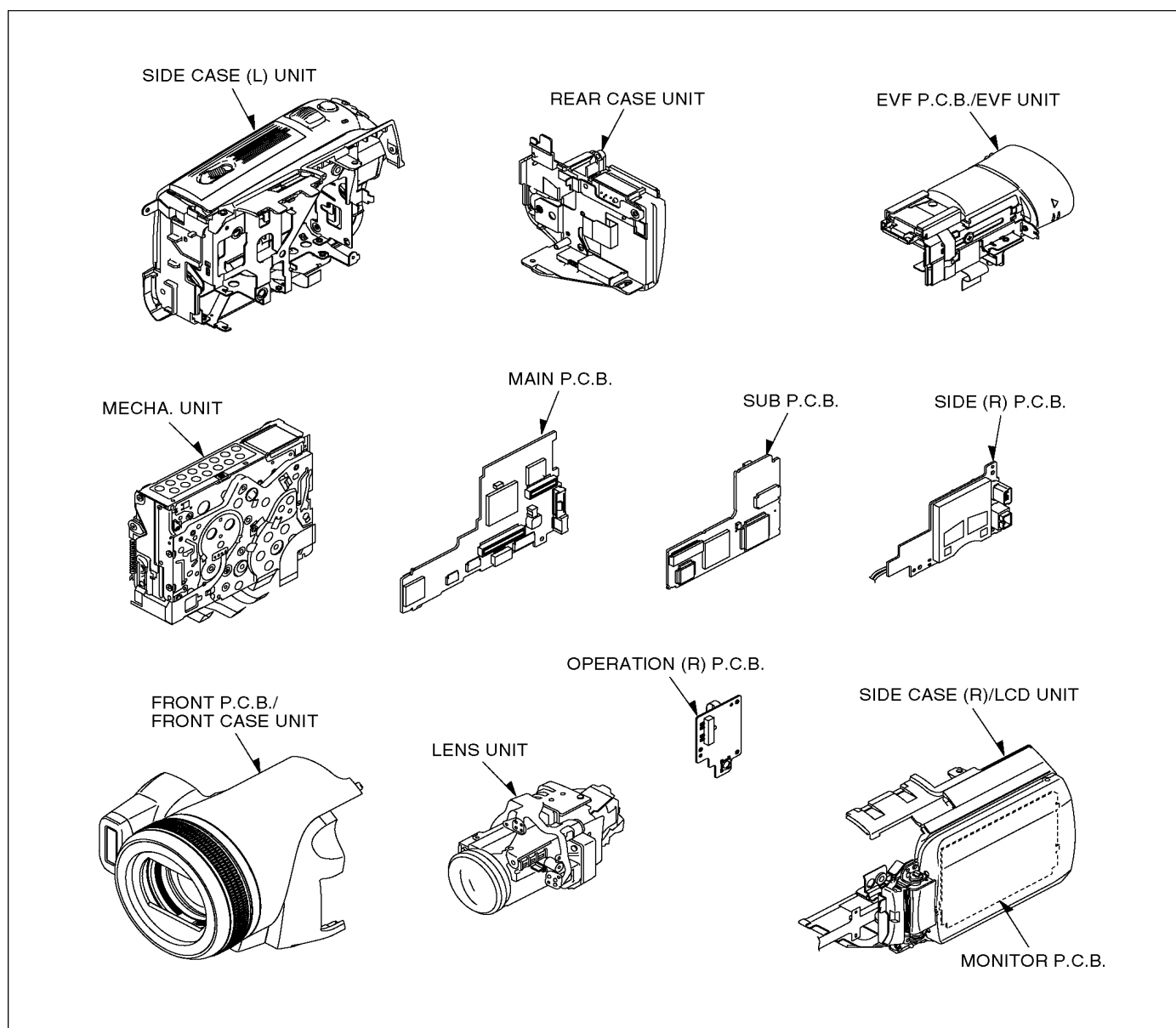

Fig. F1

8.3. Disassembly Procedures

Flow-Chart for Disassembly Procedure

No.	Item / Part	Fig.	Removal (Screw,Connector,Flex. & Other)
1	Front Case Unit	Fig.D2	2-Screws (A)
		Fig.D3	2-Screws (B)
		Fig.D4	Open the LCD Unit 1-Screw (C)
		Fig.D5	1-Connector FP6902 Front Case Unit
2	Side Case (R) Unit / LCD Unit	Fig.D6	2-Screws (D)
		Fig.D7	1-Screw (E), 1-Screw (F)
		Fig.D8	1-Screw (G) 2-Tabs 2-Connectors FP601, FP6901 Side Case (R) Unit / LCD Unit
3	EVF Unit	Fig.D9	1-Screw (H), 1-Screw (I) EVF Unit
4	Lens Unit	Fig.D10	1-Screw (J) 2-Connectors FP701, PS201 Lens Unit
5	Sub P.C.B.	Fig.D11	1-Connector PS3001 Sub P.C.B.
6	Main P.C.B.	Fig.D12	7-Connectors FP1001, FP2201, FP2202, FP2203, FP2204, FP5001, FP6903 1-Screw (K) 3-Tabs Main P.C.B.
7	Mecha. Unit	Fig.D13	Open the Cassette Cover 3-Screws (L) Mecha. Unit
8	Cassette Cover Unit, Side (L) P.C.B.	Fig.D14	4-Screws (M), 1-Screw (N), 1-Screw (O)
		Fig.D15	Remove the Cassette Cover Unit with the procedure of arrow 1,2.
		Fig.D16	1-Connector FP6101 1-Screw (P) Side (L) P.C.B.
9	Rear Case Unit	Fig.D17	1-Screw (Q) 3-Tabs Top Case
		Fig.D18	1-Screw (R) Grip Belt, Belt Plate 2-Screws (S), 1-Screw (T) Side Case (L) 1 Unit 1-Screw (U) Rear Case Unit
10	Front P.C.B.	Fig.D19	2-Connector FP6701, FP7002 2-Screws (V), 1-Screw (W) Front P.C.B.
11	LCD Det. /Side (R)/Operation (R) P.C.B.	Fig.D20	1-Connector PS6301 3-Screws (X) Side Case (R) 1 Unit 1-Screw (Y) LCD Det. P.C.B. Note: Open the LCD Unit, when you attach the LCD Det. P.C.B.
		Fig.D21	2-Screws (Z), 2-Screws (a)
		Fig.D22	1-Screw (b) 1-Connector FP602 Hinge Support Plate
		Fig.D23	1-Connector FP6302 1-Screw (c) Side (R) P.C.B.
		Fig.D24	3-Screws (d) Operation (R) P.C.B.

No.	Item / Part	Fig.	Removal (Screw,Connector,Flex. & Other)
12	Monitor P.C.B.	Fig.D25	2-Screws (e), 2-Screws (f) LCD Case (Upper) Unit
		Fig.D26	1-Connector FP902 LCD Hinge Unit, LCD Earth Plate
		Fig.D27	1-Connector FP903 3-Tabs Monitor P.C.B.
13	EVF P.C.B.	Fig.D28	1-Tab View ADJ. / EVF LCD Unit
		Fig.D29	2-Screws (g)
		Fig.D30	4-Tabs EVF Case (Upper)
		Fig.D31	2-Tabs 1-Connector FP853 EVF Case (Lower)
		Fig.D32	1-Connector FP854 3-Tabs EVF P.C.B.

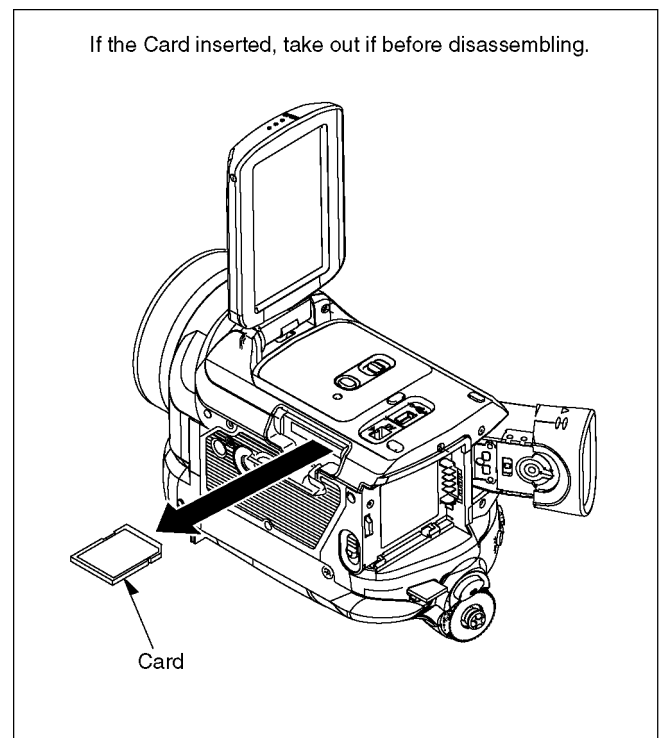

Fig. D1

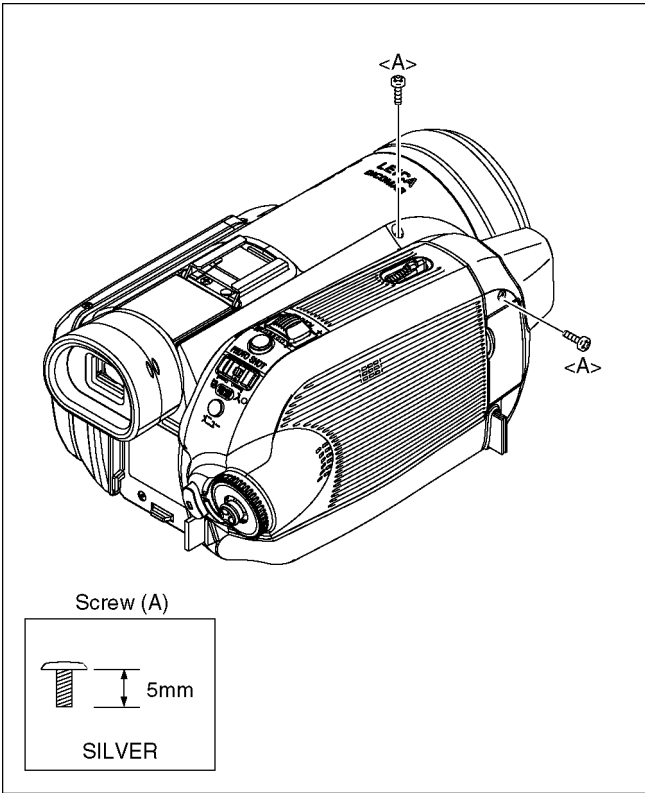

Fig. D2

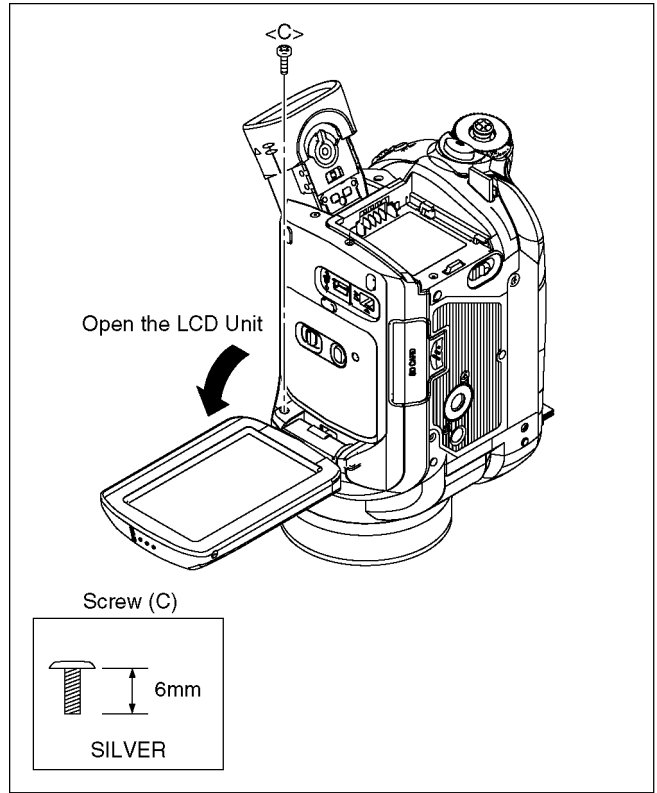

Fig. D4

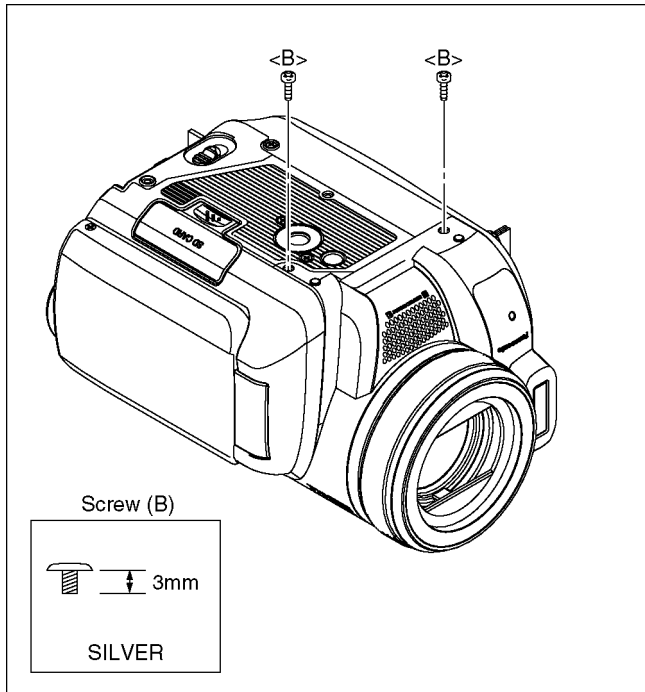

Fig. D3

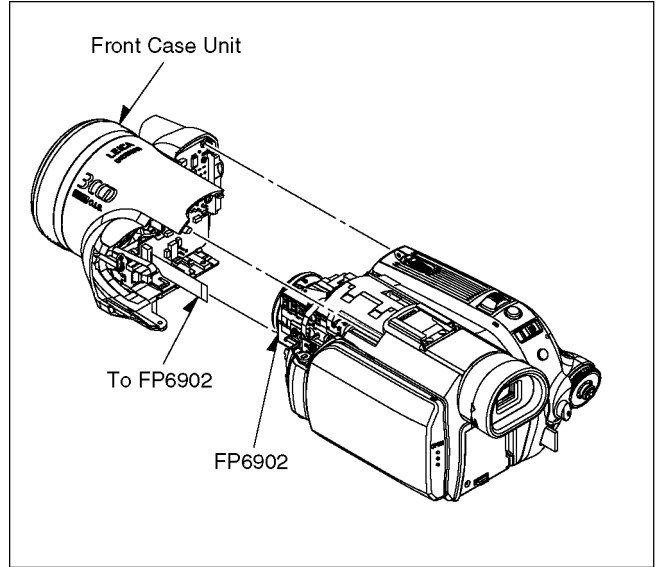

Fig. D5

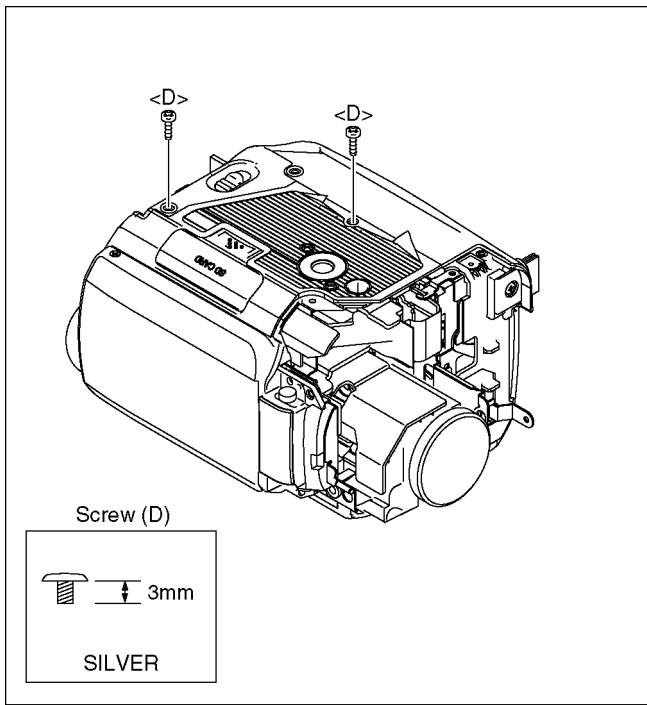

Fig. D6

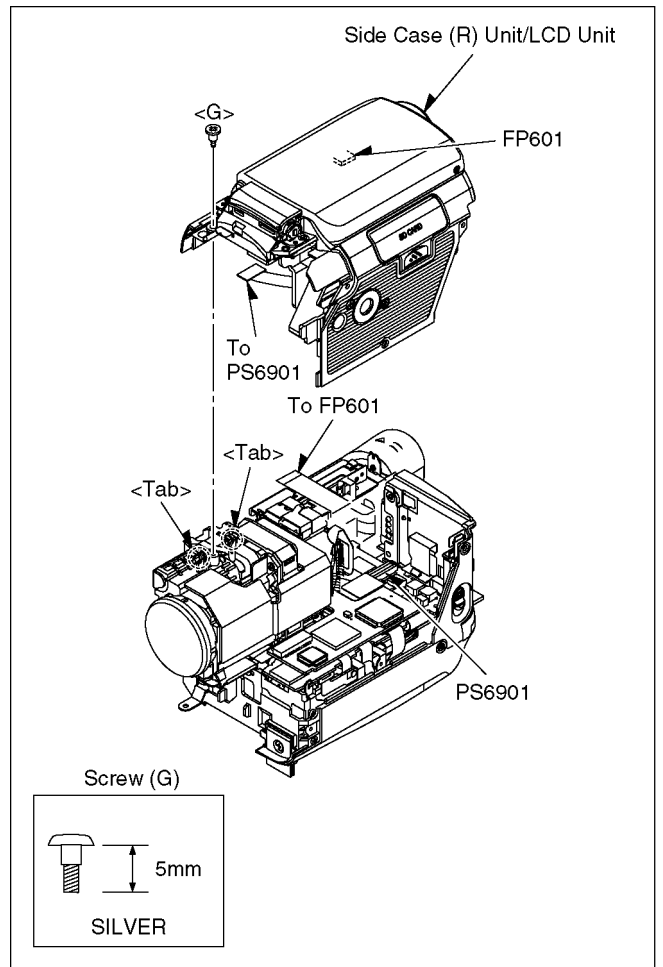

Fig. D8

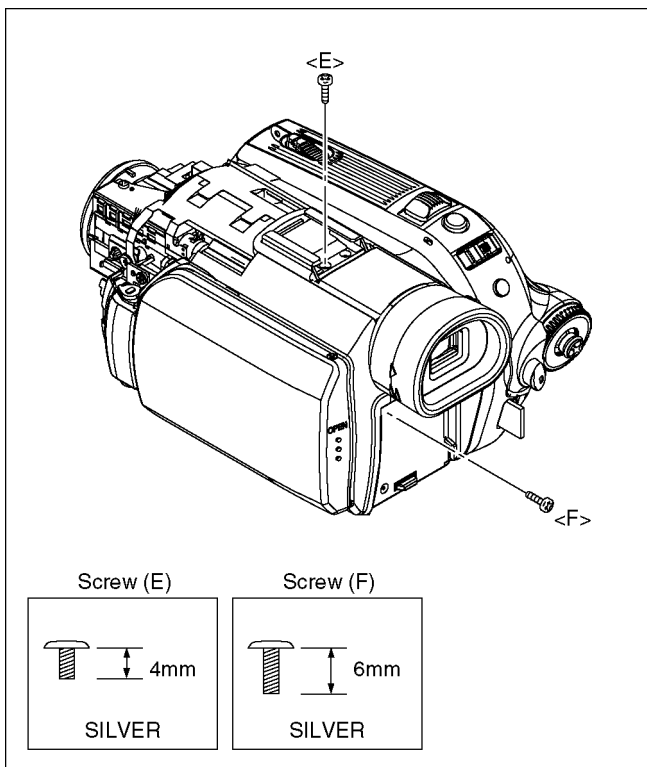

Fig. D7

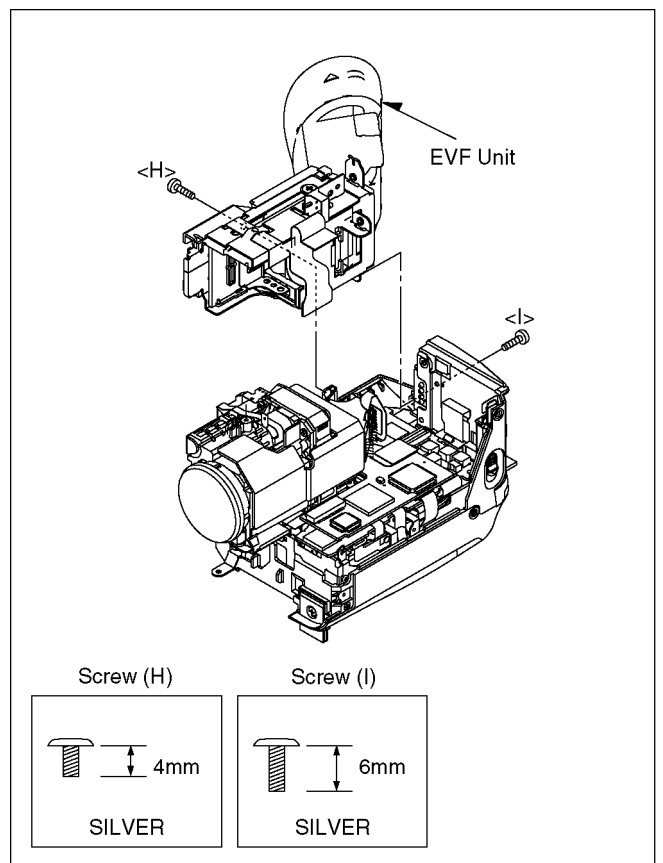

Fig. D9

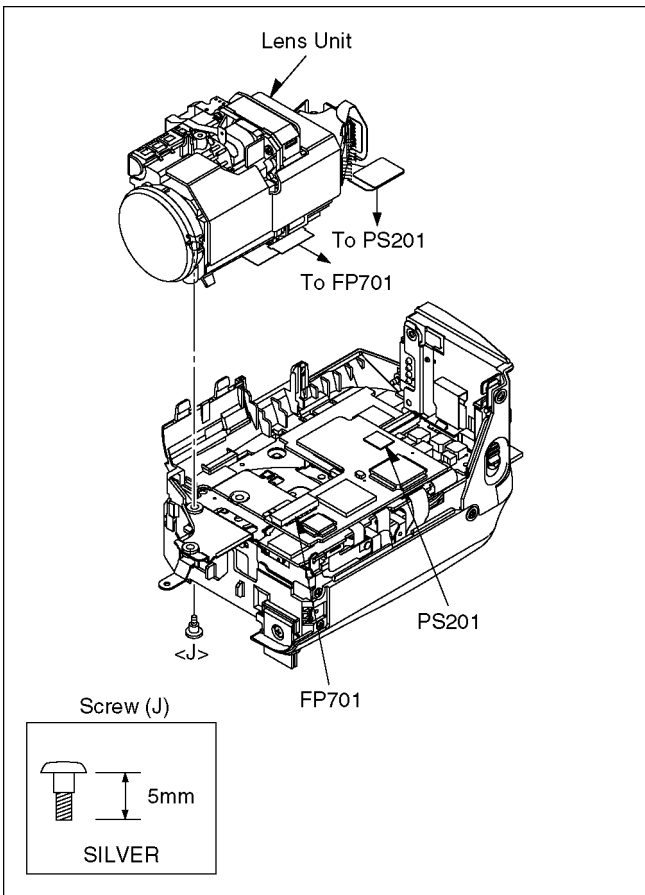

Fig. D10

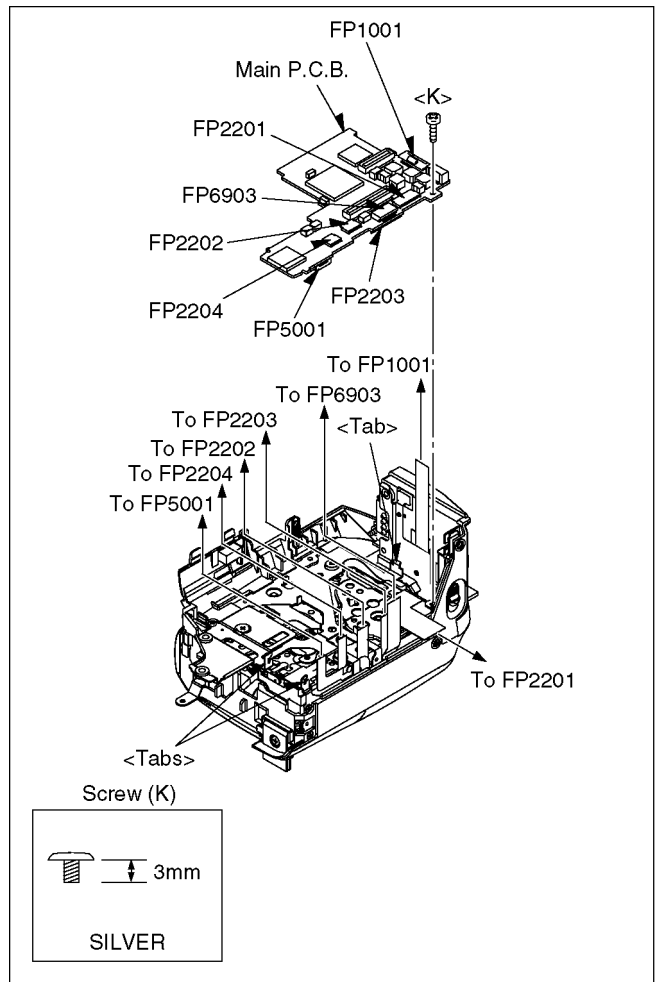

Fig. D12

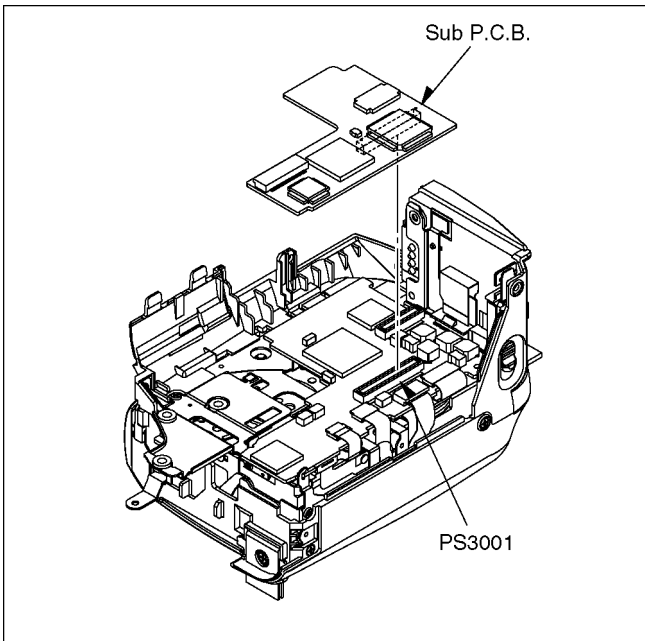

Fig. D11

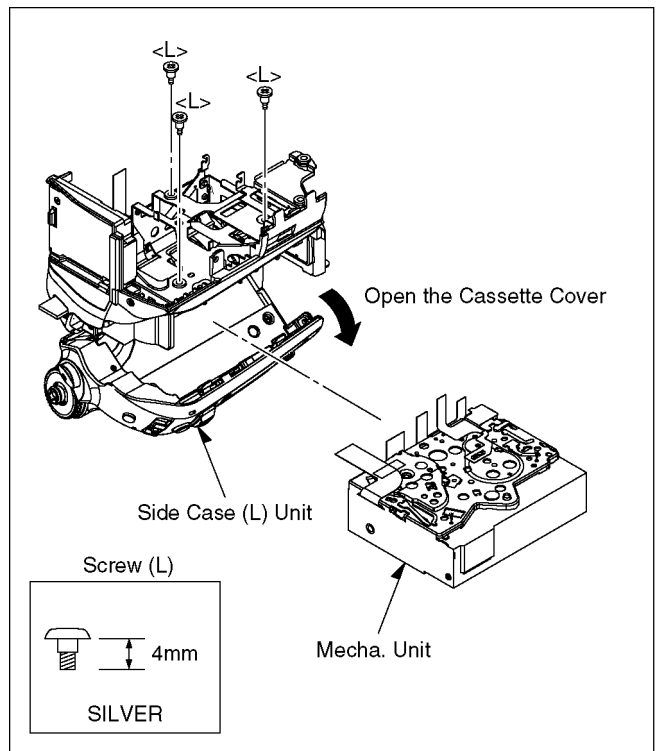

Fig. D13

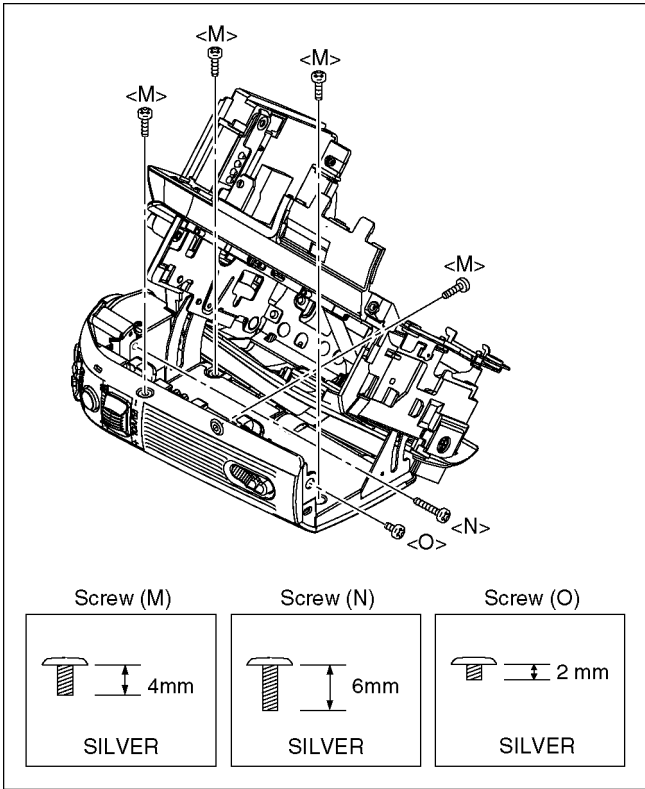

Fig. D14

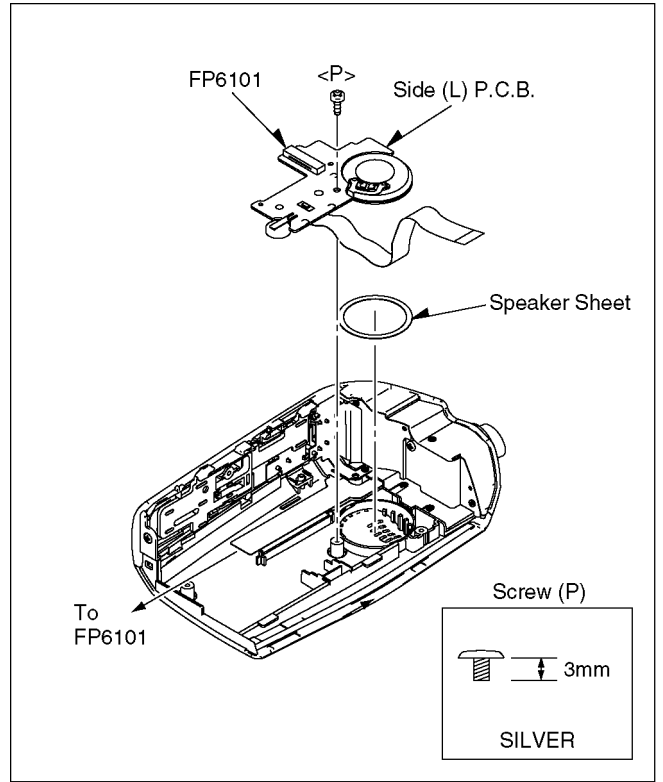

Fig. D16

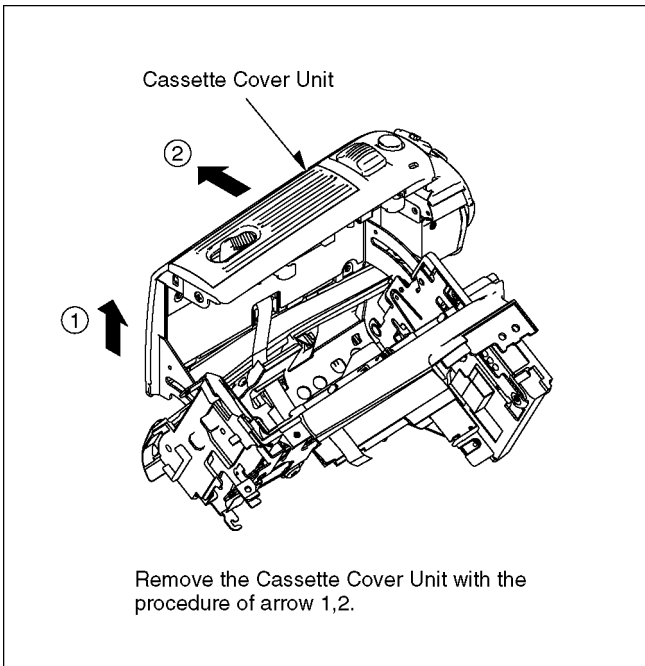

Fig. D15

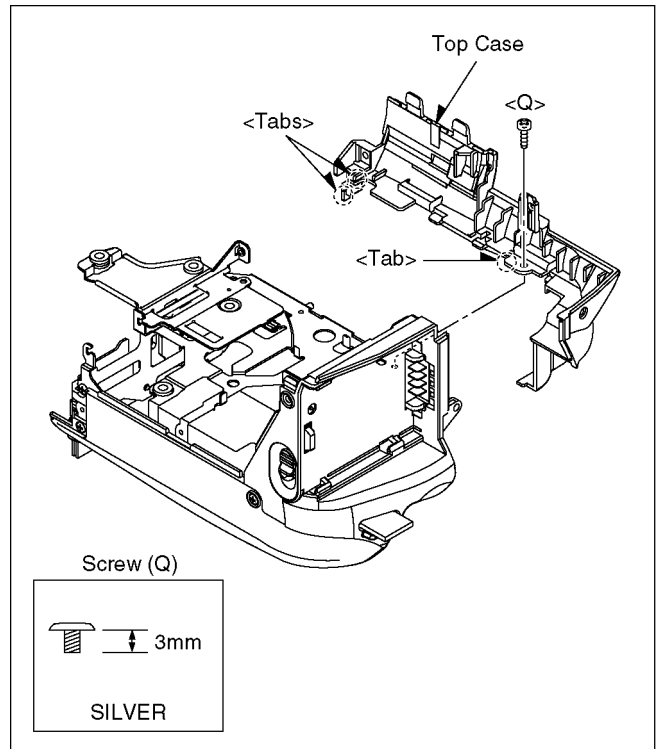

Fig. D17

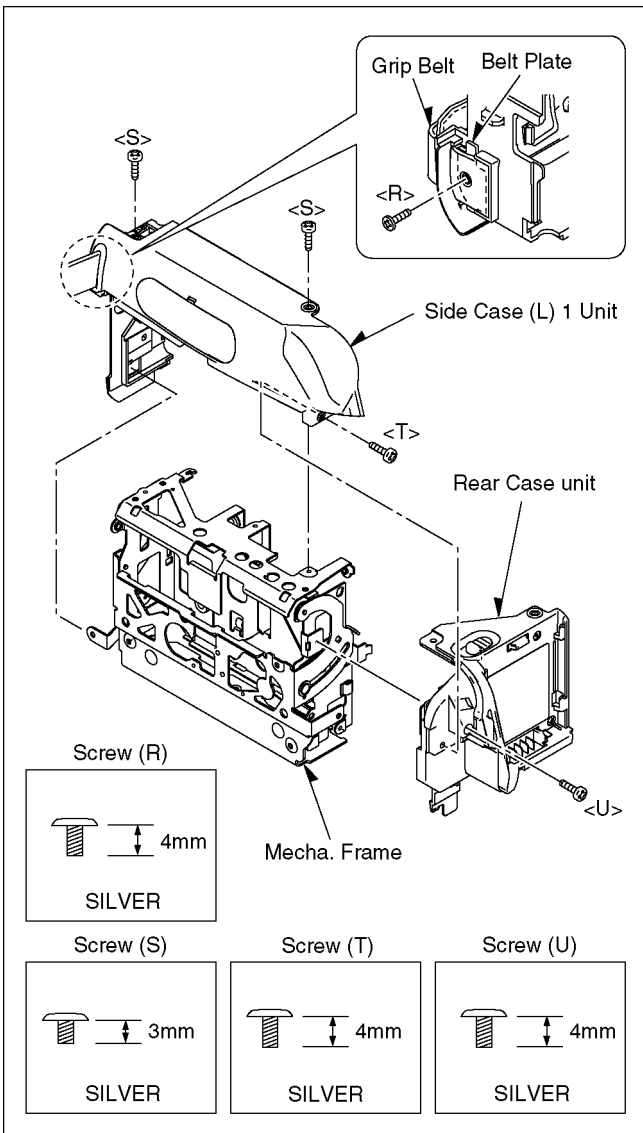

Fig. D18

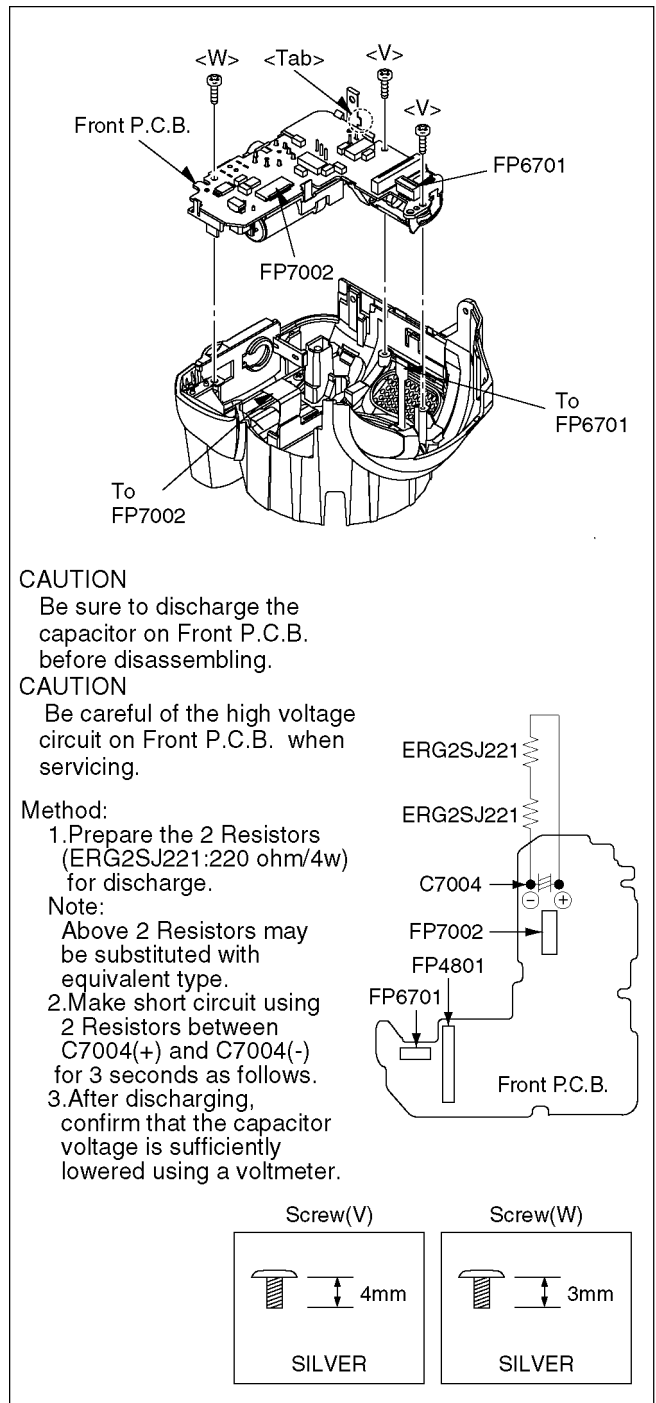

Fig. D19

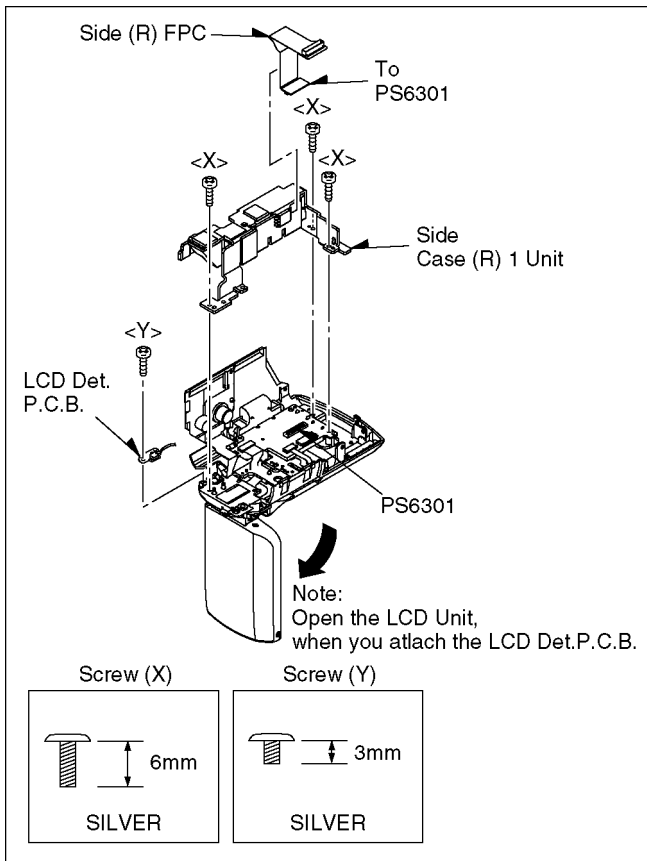

Fig. D20

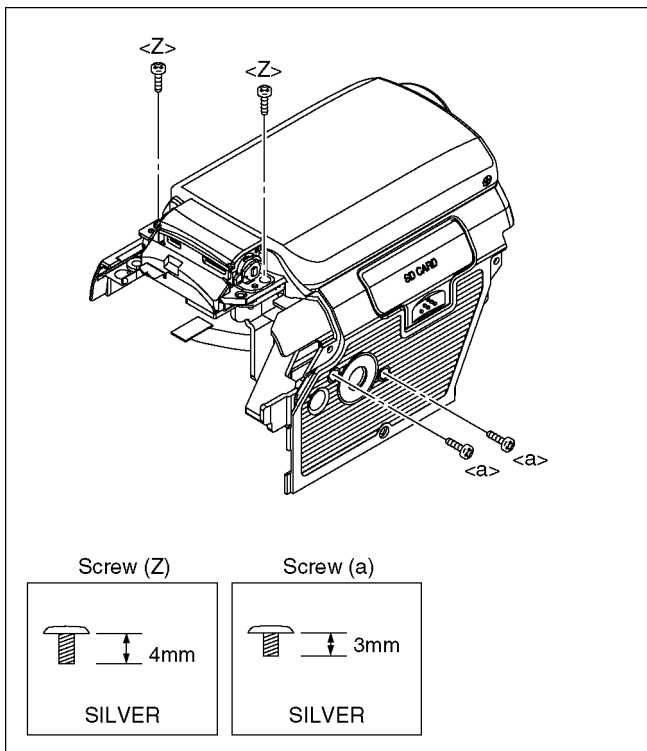

Fig. D21

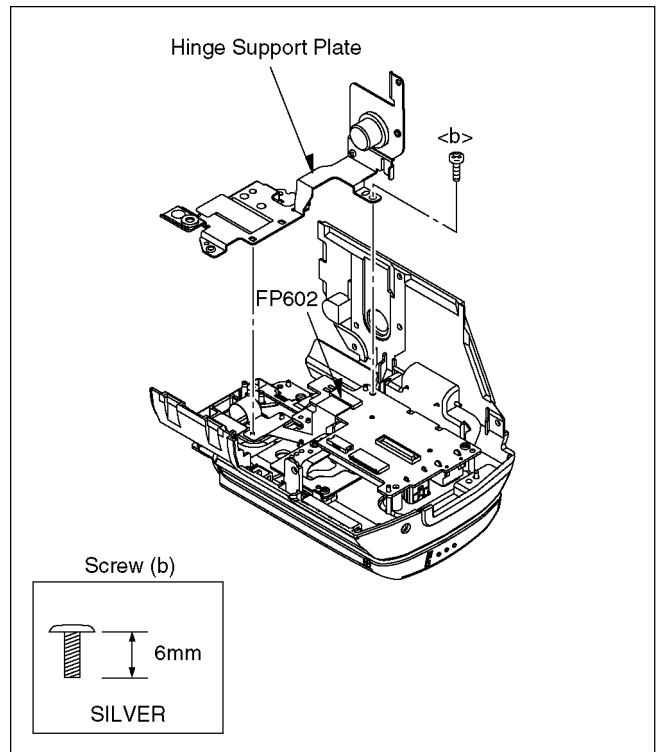

Fig. D22

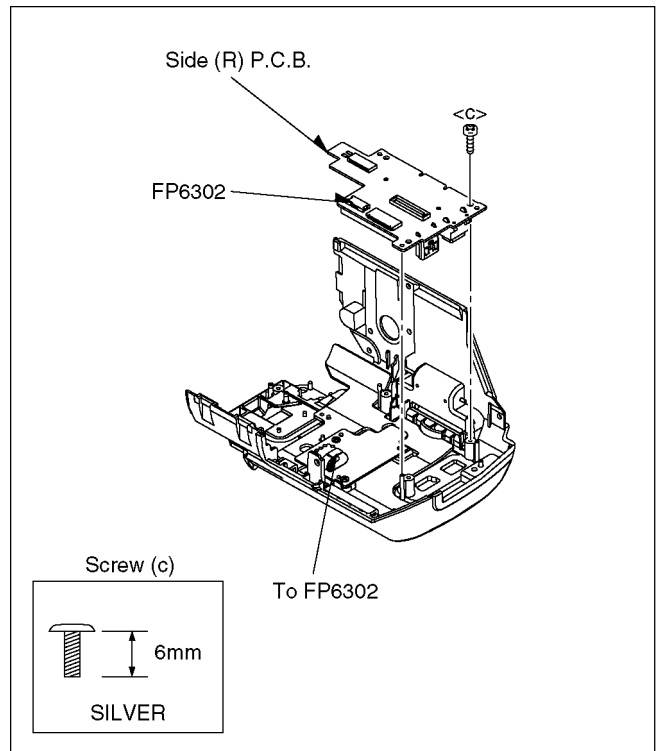

Fig. D23

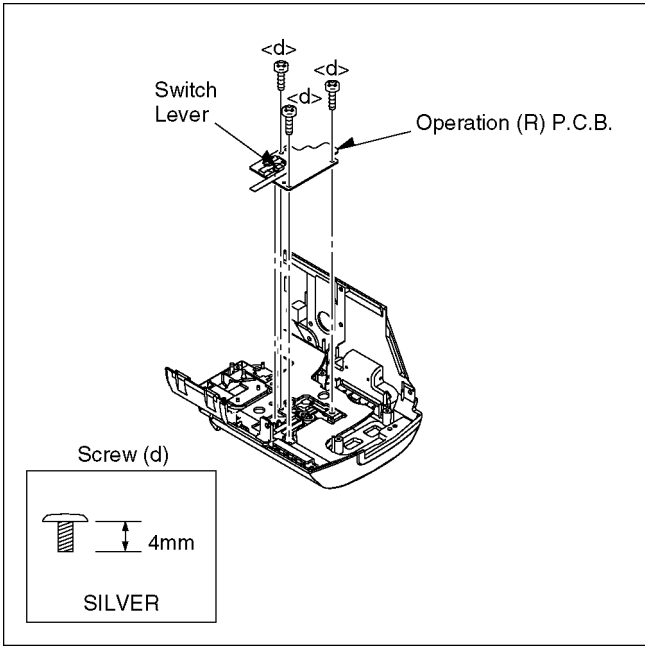

Fig. D24

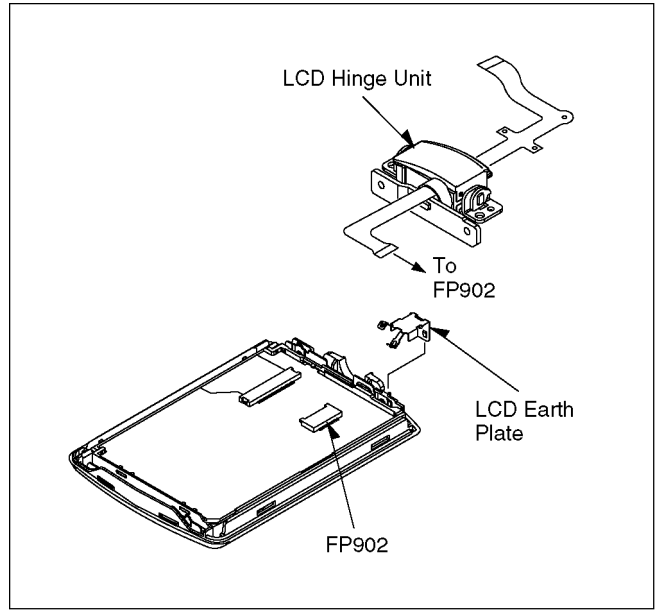

Fig. D26

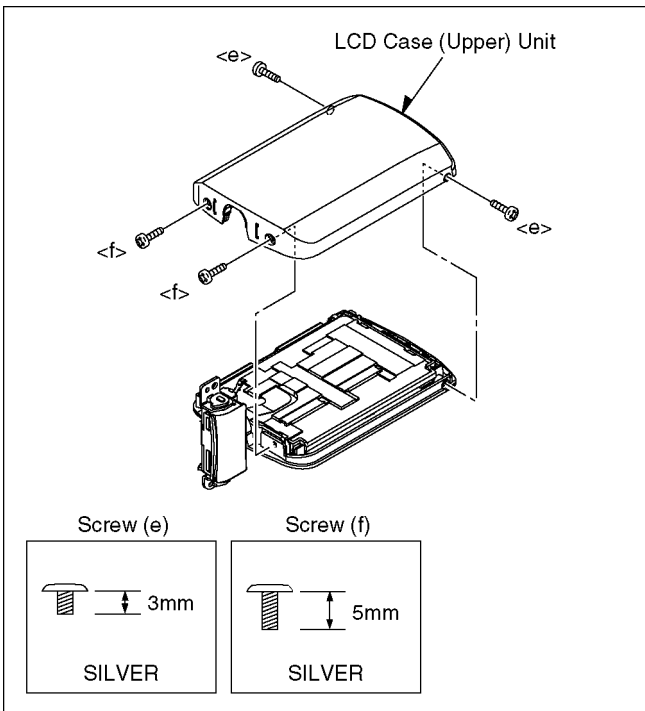

Fig. D25

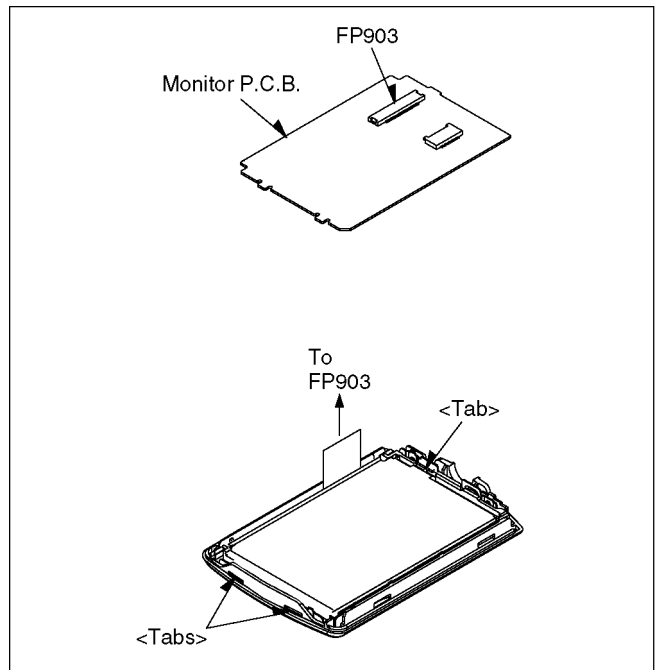

Fig. D27

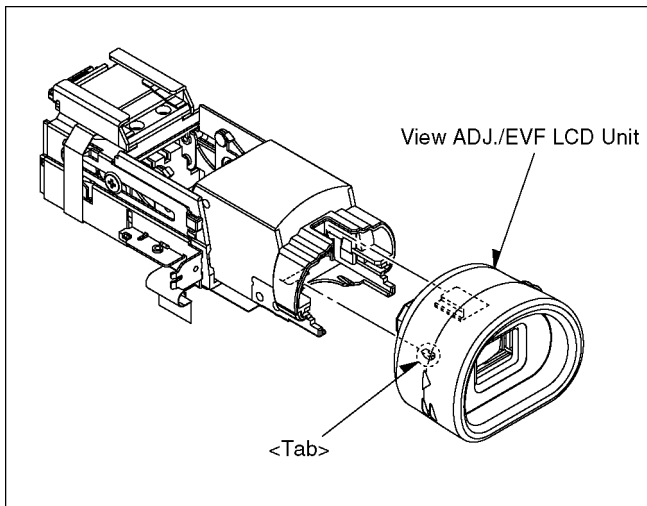

Fig. D28

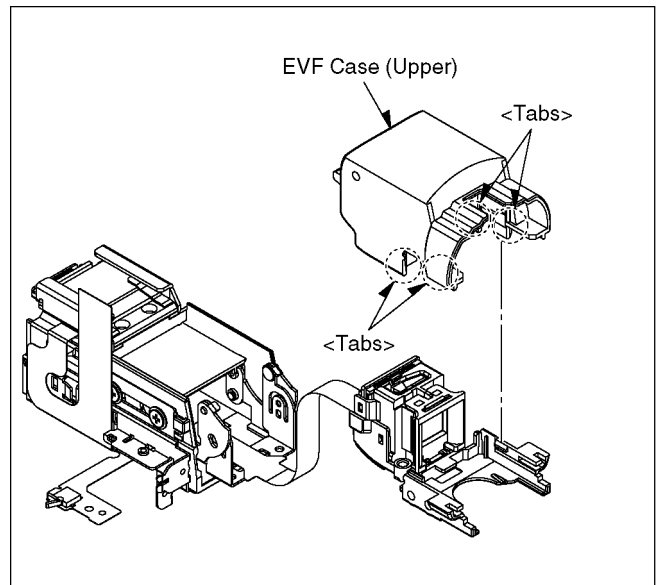

Fig. D30

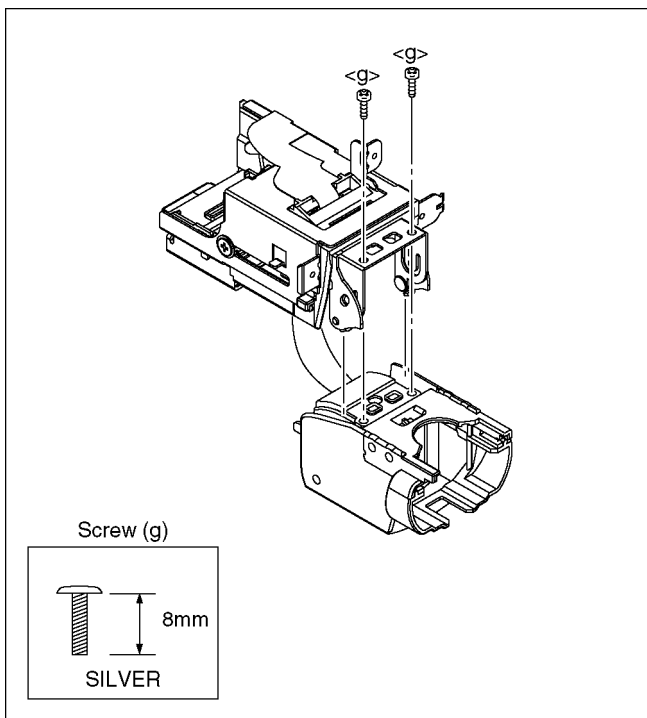

Fig. D29

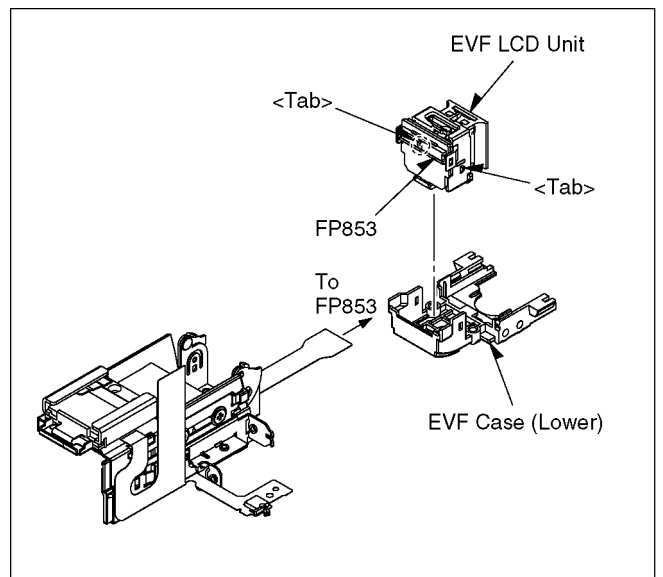

Fig. D31

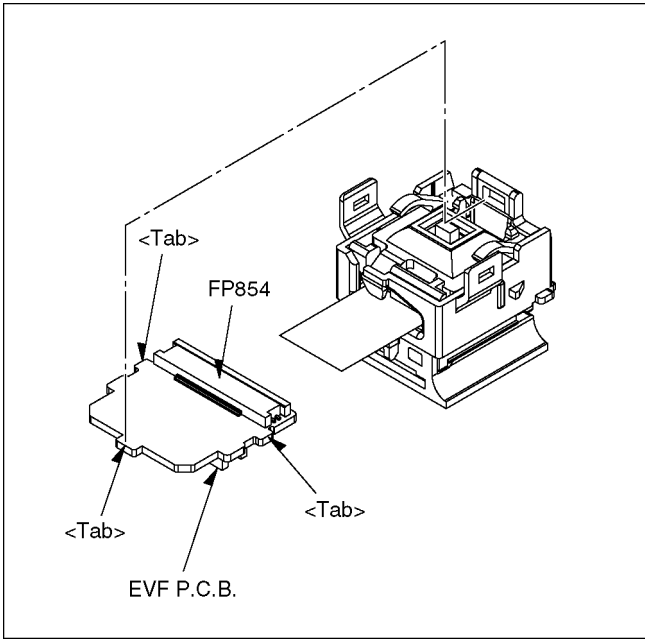

Fig. D32

8.4. Disassembly Procedures Mecha. Unit

Flow-Chart for Disassembly Procedure

No.	Item / Part	Fig.	Removal (Screw, Connector, Flex. & Other)
1	Cassette Up Unit	Fig. M1	It makes the mechanism position in Eject condition (For Battery)
		Fig. M2	3-Screws (A)
		Fig. M3	3-Tabs I remove the piece arrangement unit from rail department
2	Cylinder Unit	Fig. M4	1-Screw (B)
		Fig. M5	3-Screw (C) Cylinder Unit

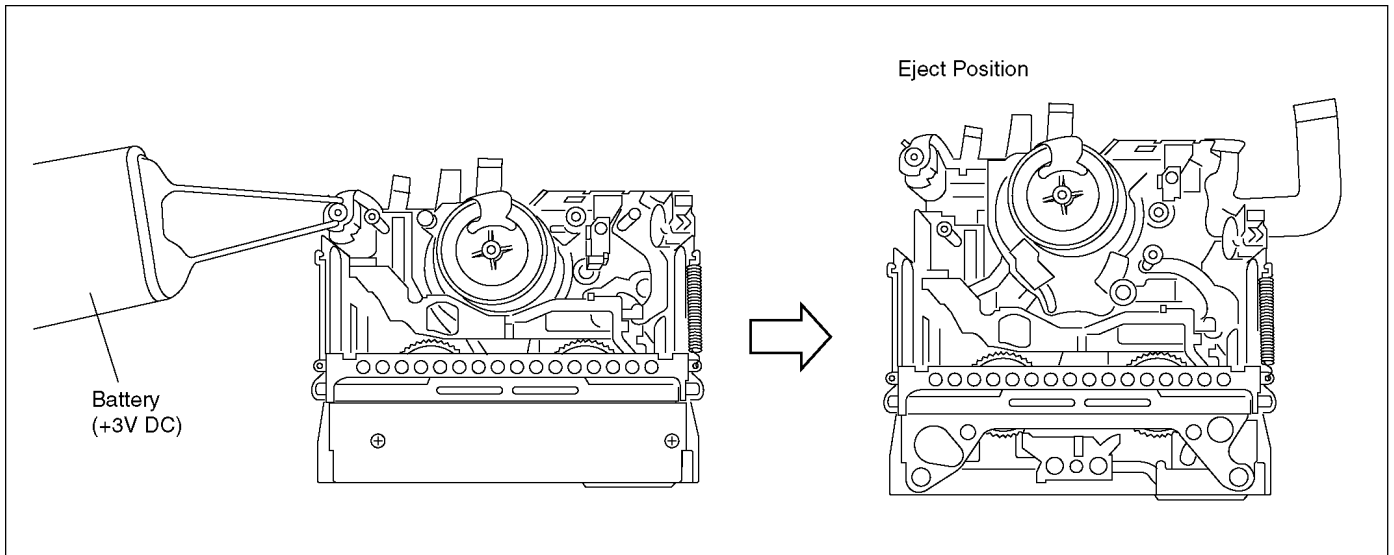

Fig. M1

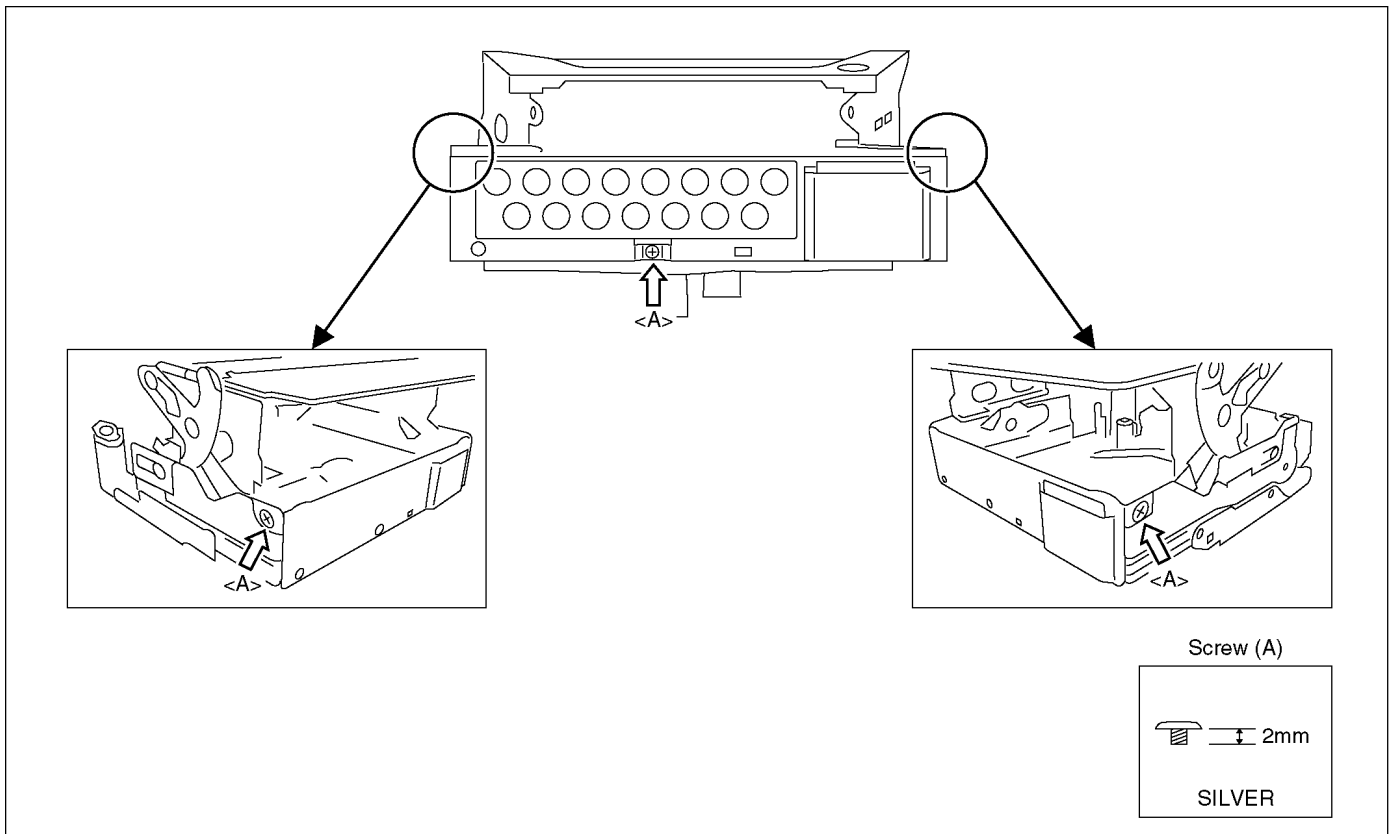

Fig. M2

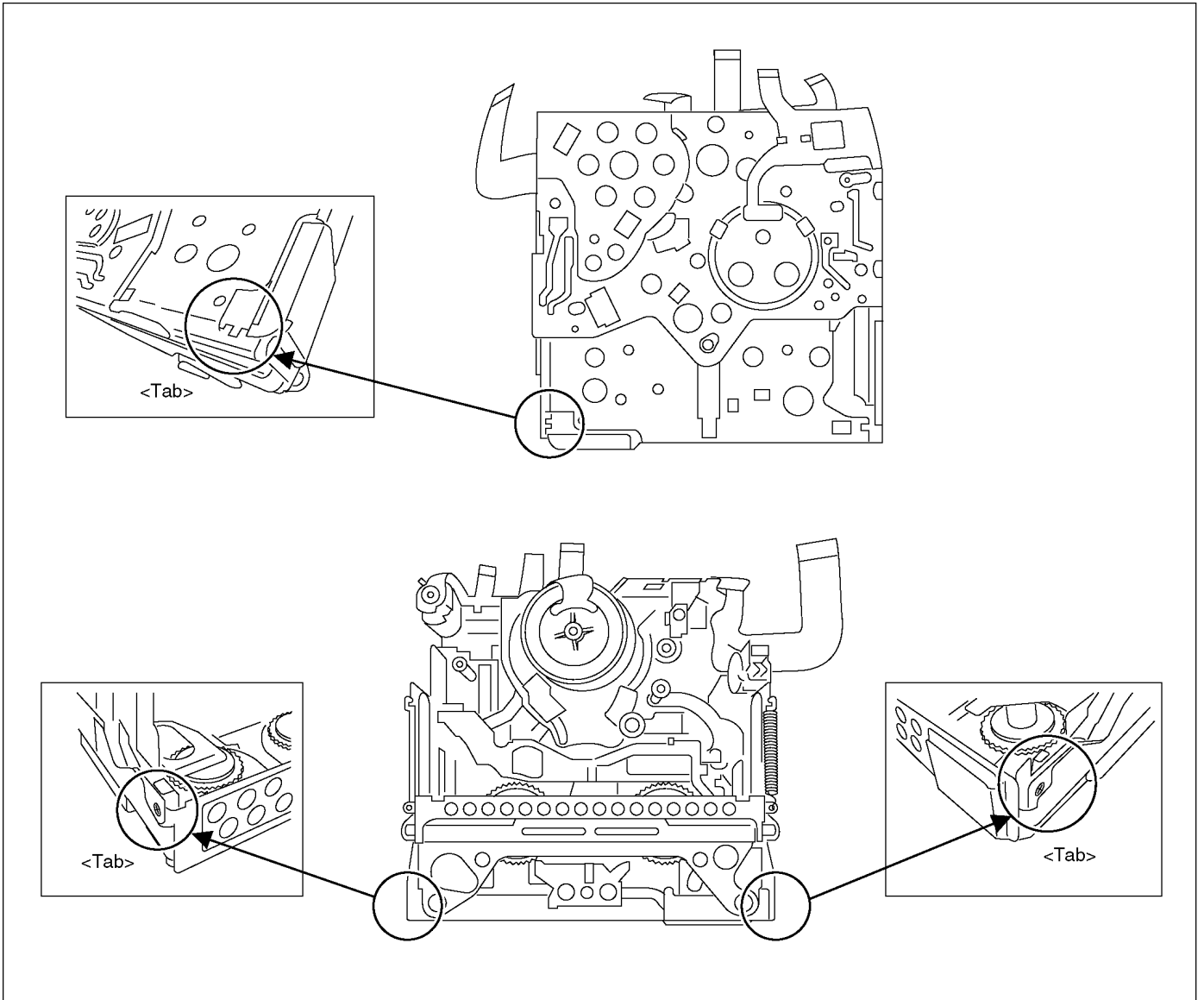

Fig. M3

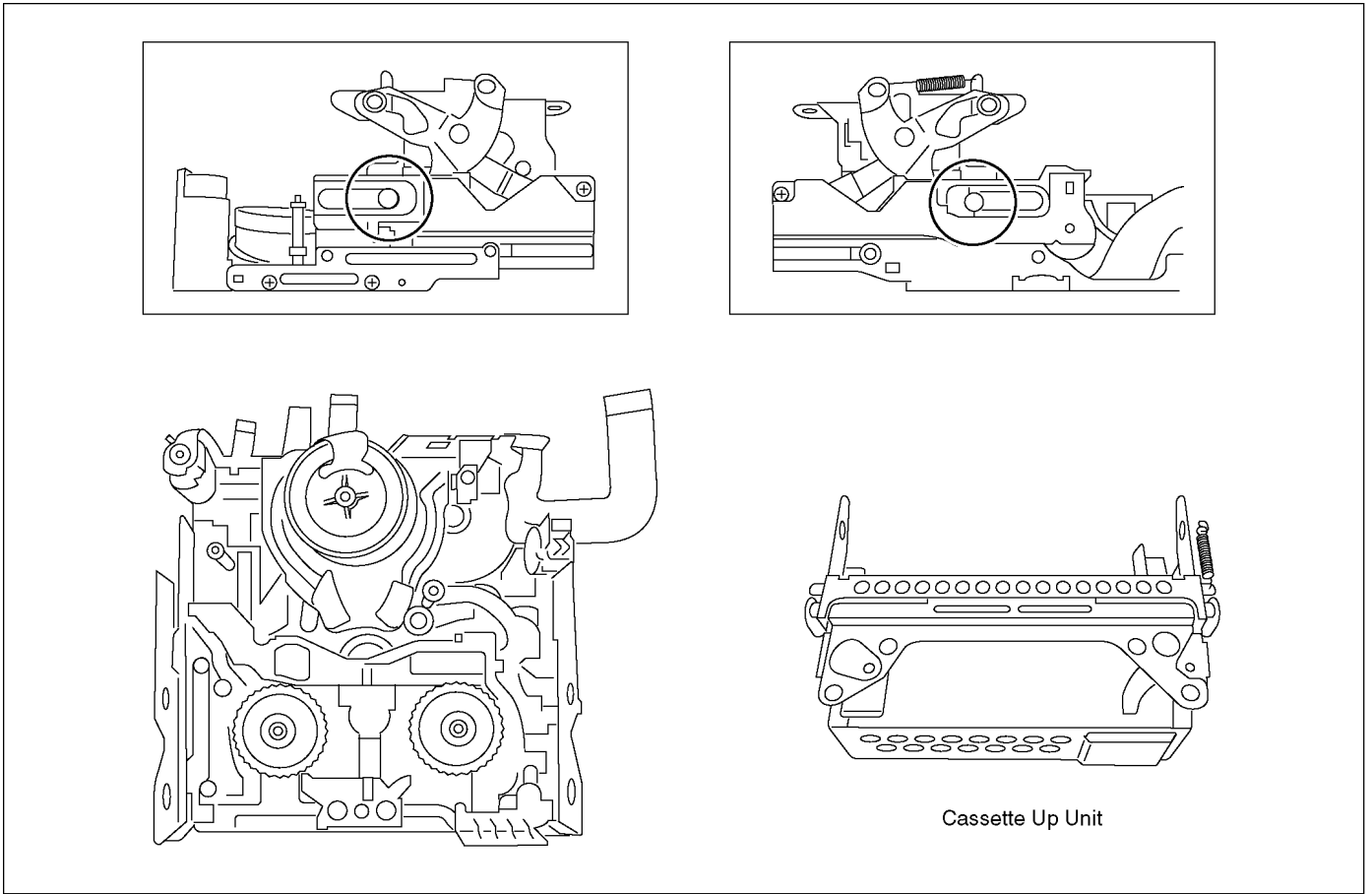

Fig. M4

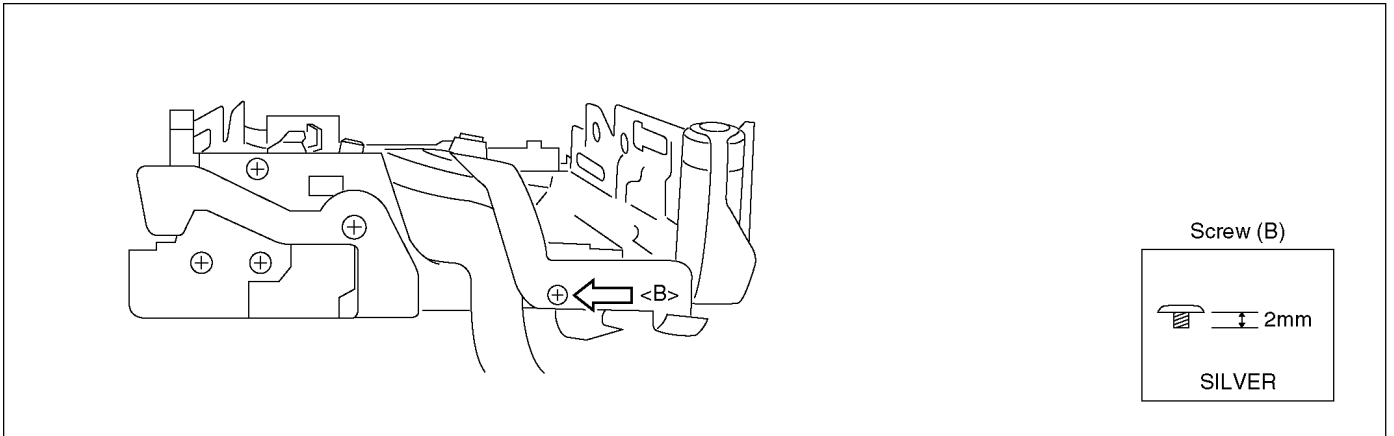

Fig. M5

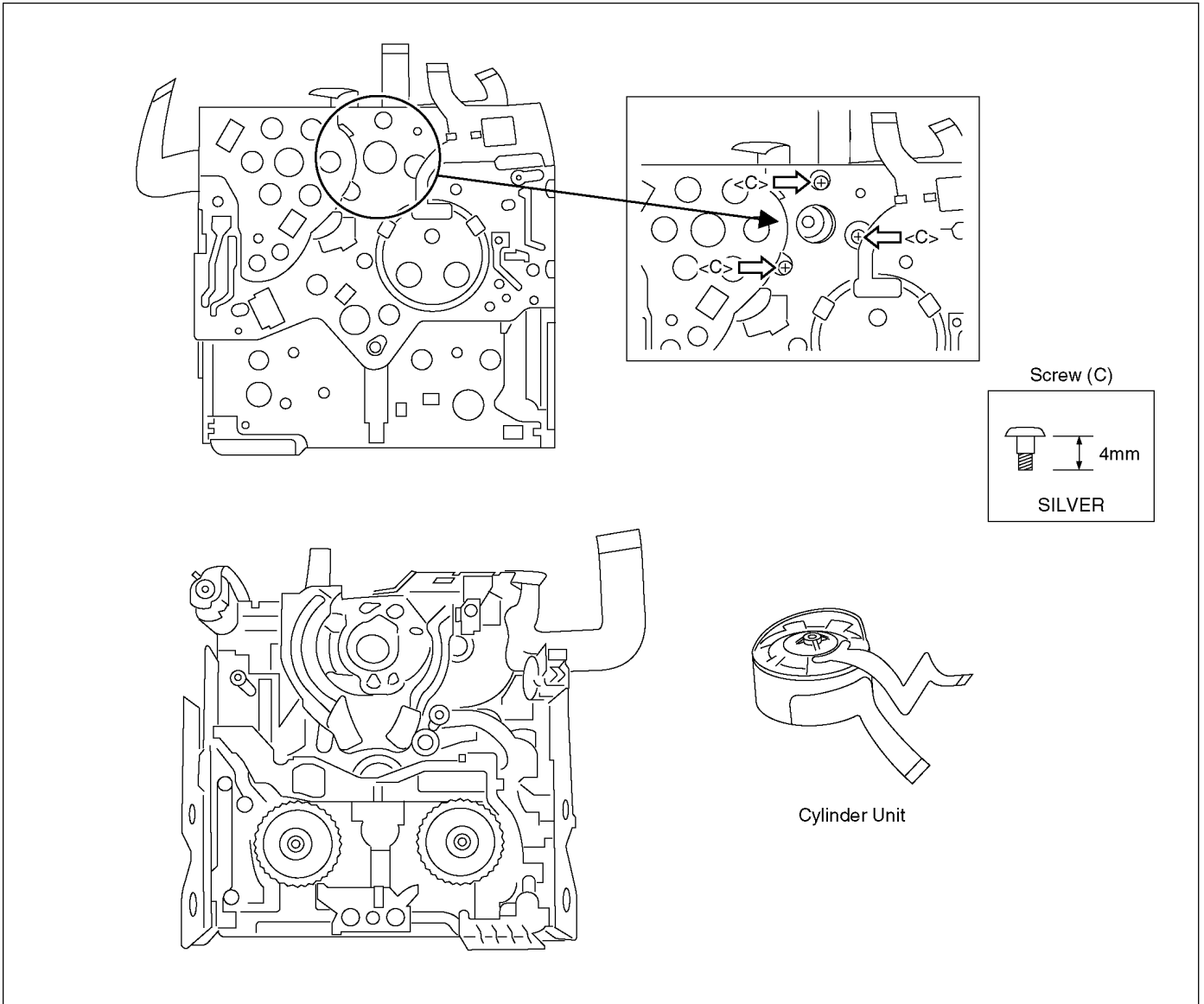

Fig. M6

8.5. Disassembly Procedures of Camera Lens Unit

The following flowchart describes order or steps for removing the Camera lens unit and certain printed circuit boards in order to make access to the item needing service.

To reassemble the unit follow the steps in reverse order.

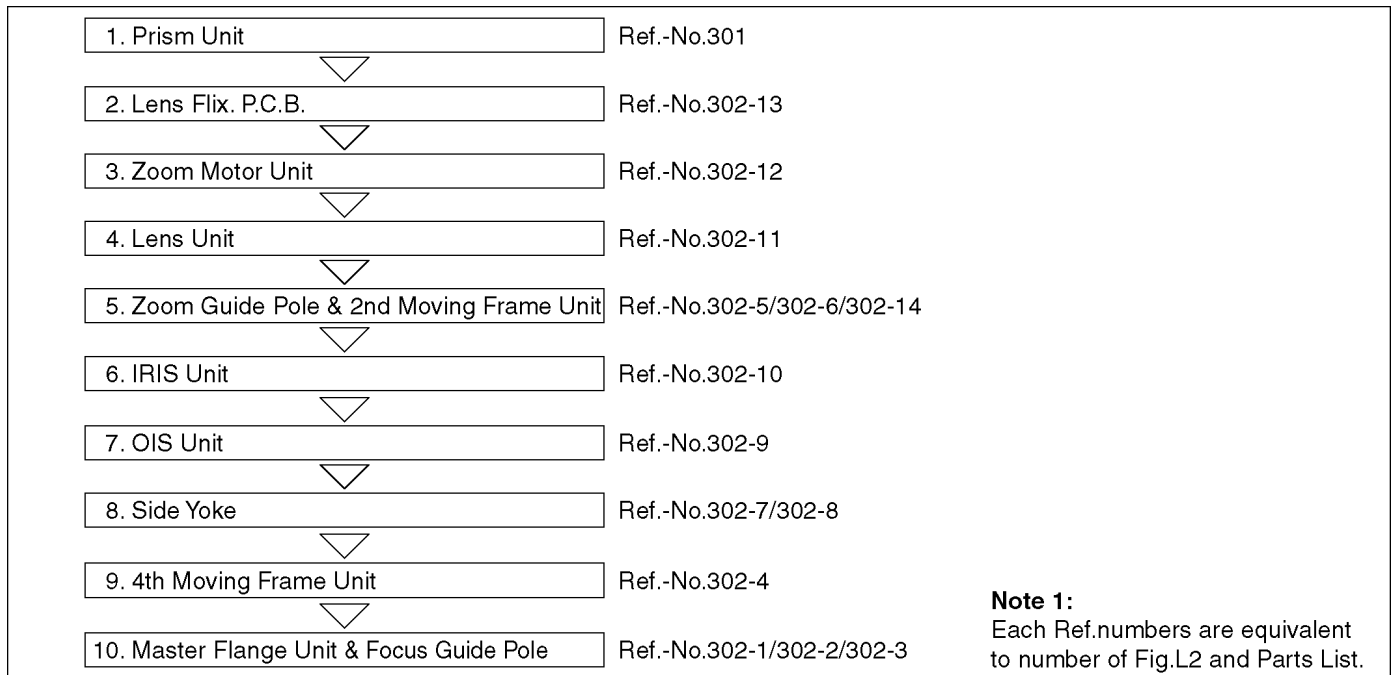

Fig. L1

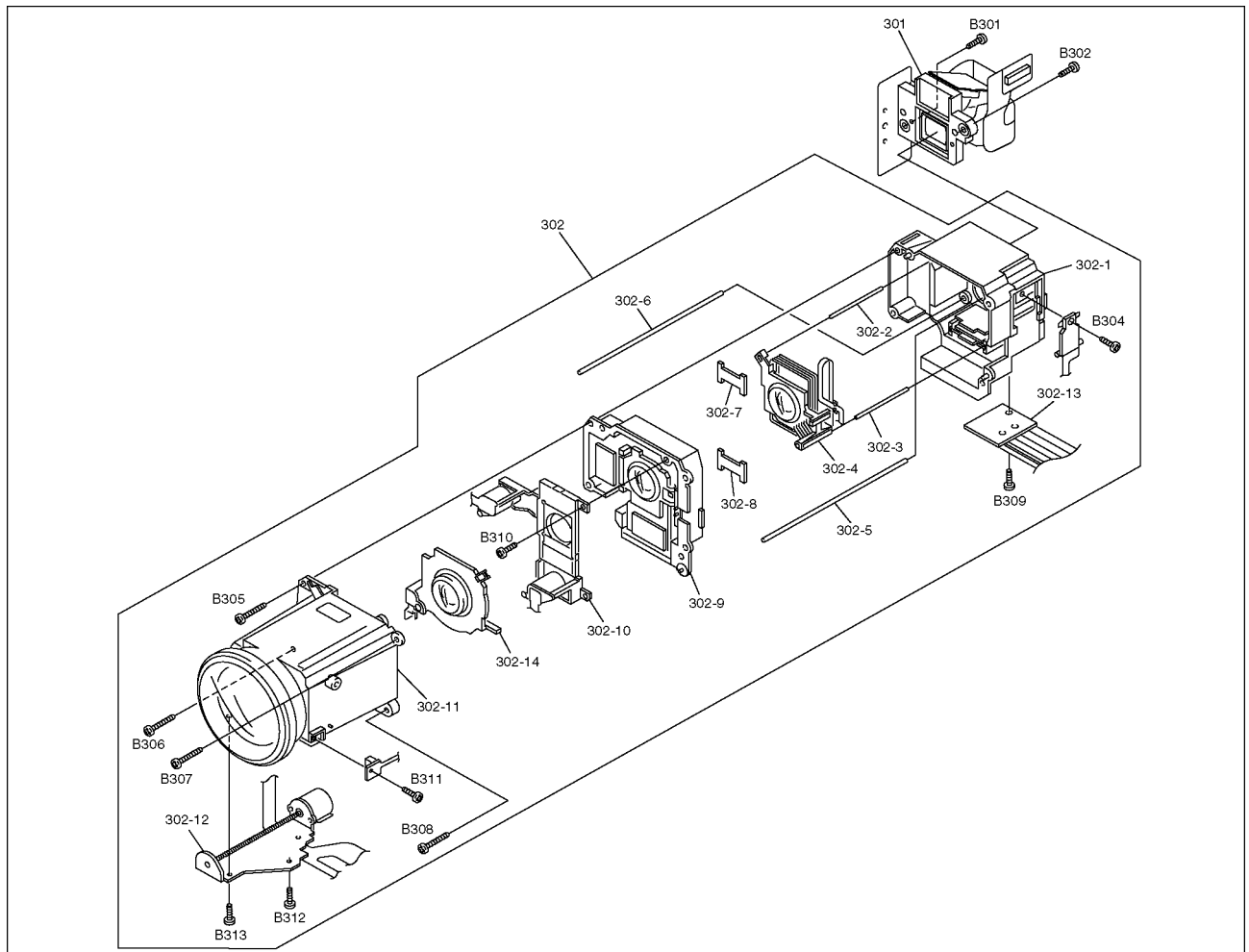

Fig. L2

9 Measurements and Adjustments

9.1. Service Positions

9.1.1. List of the extension cables

Use the following extension cables when checking or adjusting individual circuit boards except module Parts.
(Main P.C.B. and Sub P.C.B.)

Ref.	Part No.	Pin	Part Name	Connection	Q'ty	Remarks
(1)	VFK1575C4520	45	Flat Cable	FP6902 (Main) - FP4801 (Front)	1	as NV-GS400
(2)	VFK1575C4520	45	Flat Cable	FP701 (Sub) - Lens Unit	1	as NV-GS400
(3)	VFK1453	40	Flat Cable	PS201 (Sub) - Prism Unit	1	as NV-GS200
(4)	VFK1716	25	Flat Cable	FP602 (Side R) - FP902 (Monitor)	1	as NV-GX5
(5)	VFK1465	5	Flat Cable	FP6302 (Side R) - Operation (R) Unit	1	as NV-GS50
(6)	VFK1440	10	Flat Cable	FP6701 (Front) - MF Sensor Unit	1	as NV-DS7
(7)	VFK1993	60	Flat Cable	PS6901 (Main) - PS6301 (Side R)	1	as NV-GS300
(8)	VFK1978	31	Flat Cable	FP601 (Side R) - FP853 (EVF)	1	as SDR-S100

9.1.2. Checking and repairing individual circuit boards except module parts (Main P.C.B. and Sub P.C.B.)

How to use extension cables.

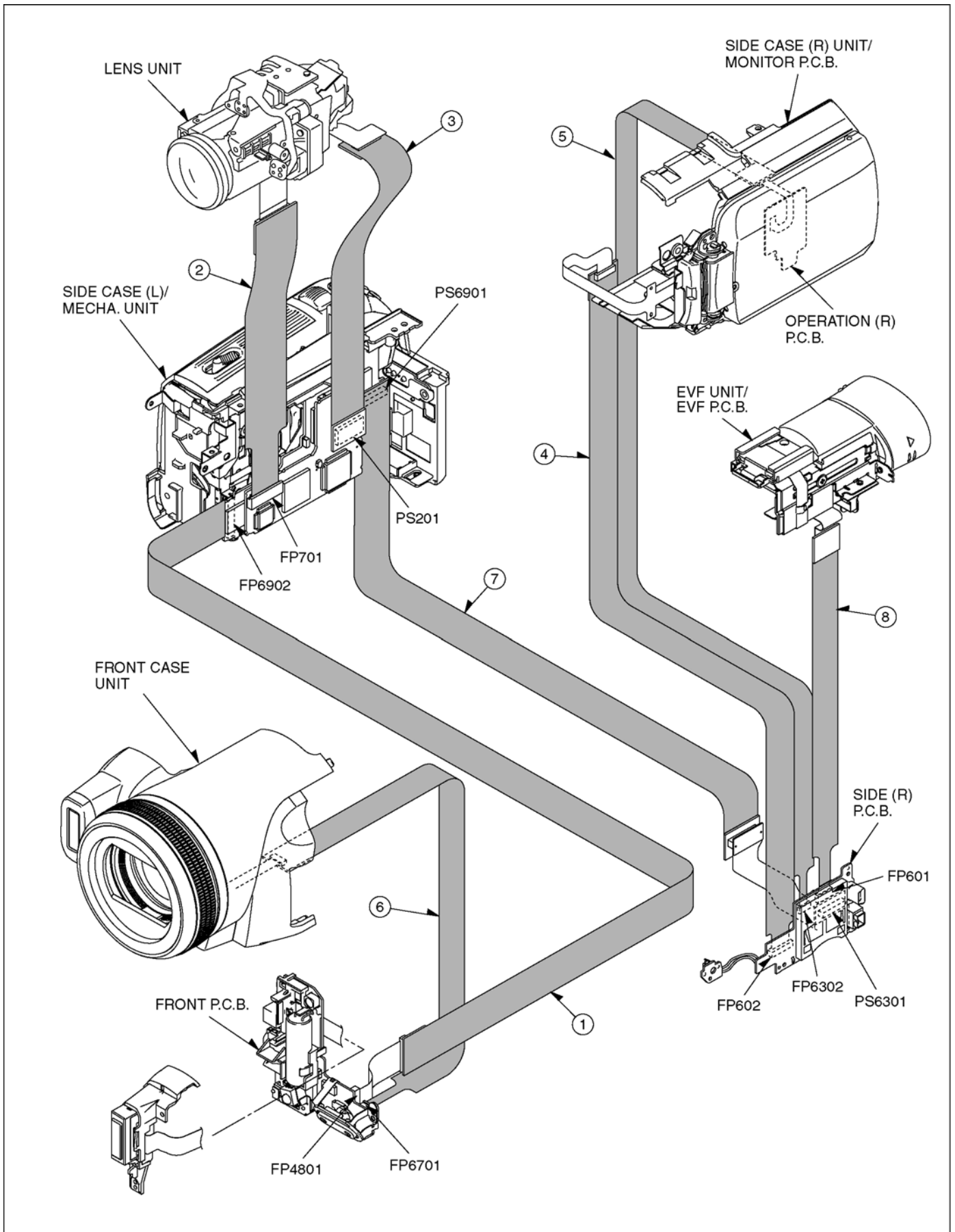

9.2. Location for Connectors of the Main P.C.B. & Sub P.C.B.

9.2.1. Main P.C.B.

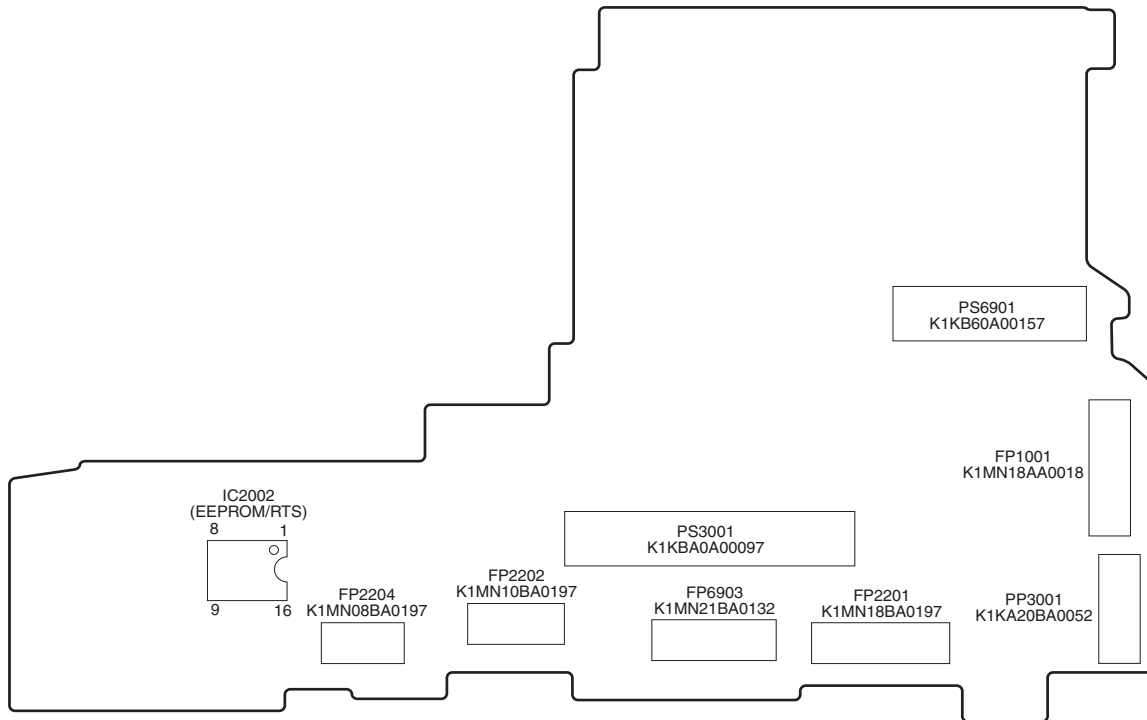

(COMPONENT SIDE)

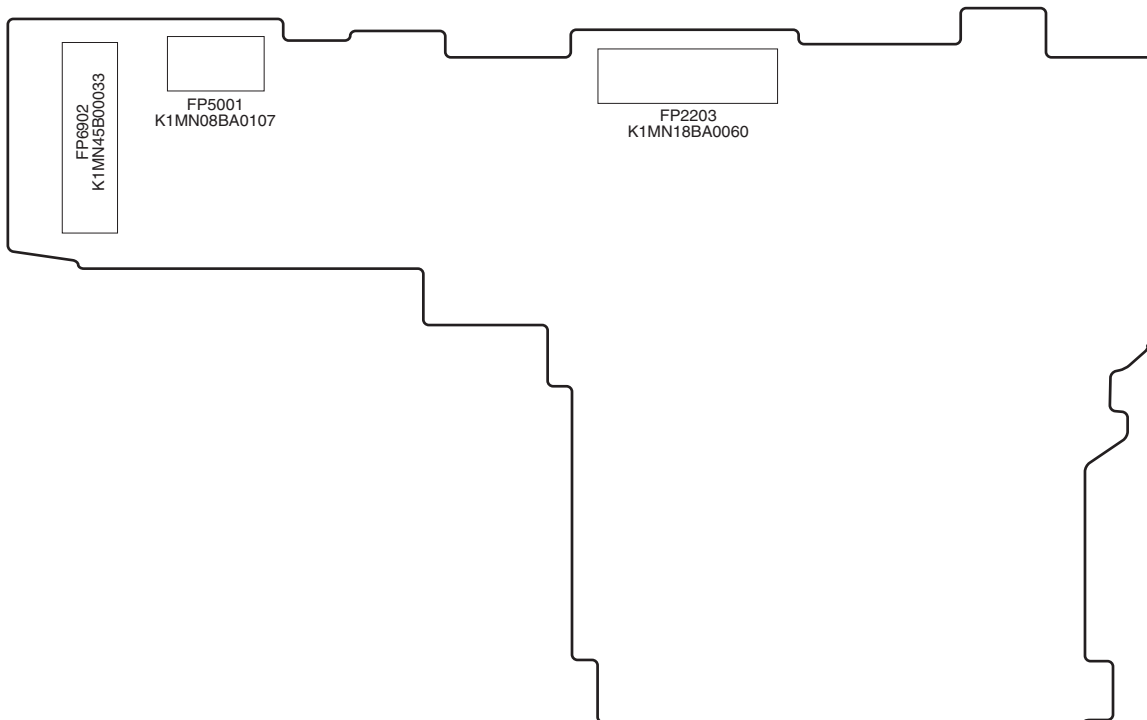

(FOIL SIDE)

9.2.2. Sub P.C.B.

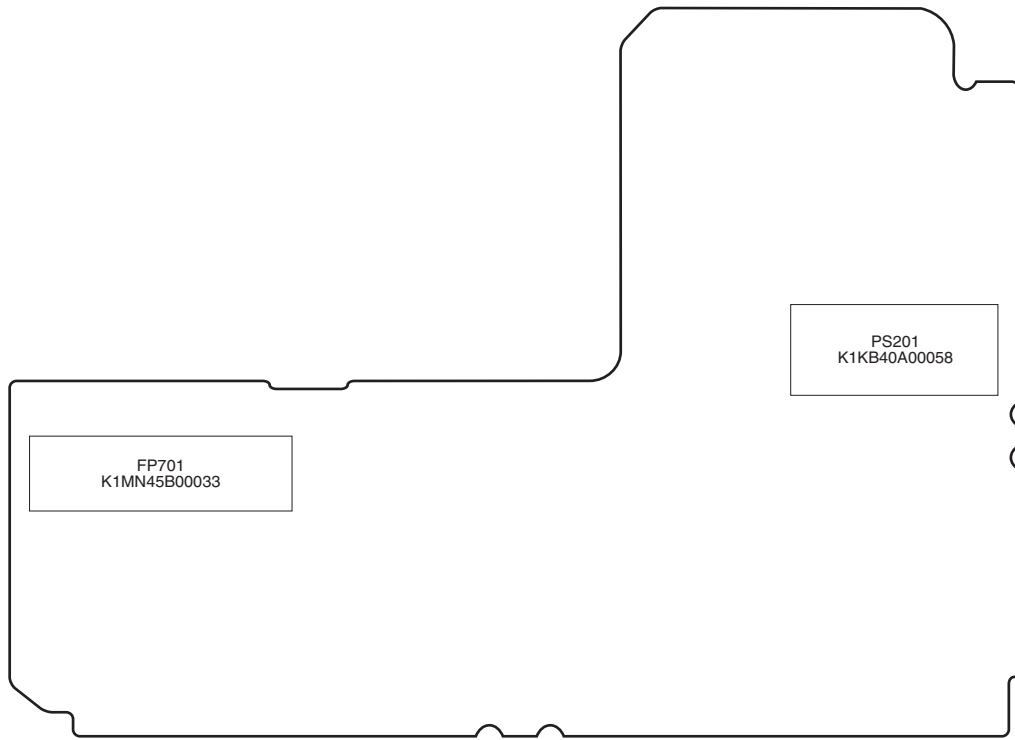

(COMPONENT SIDE)

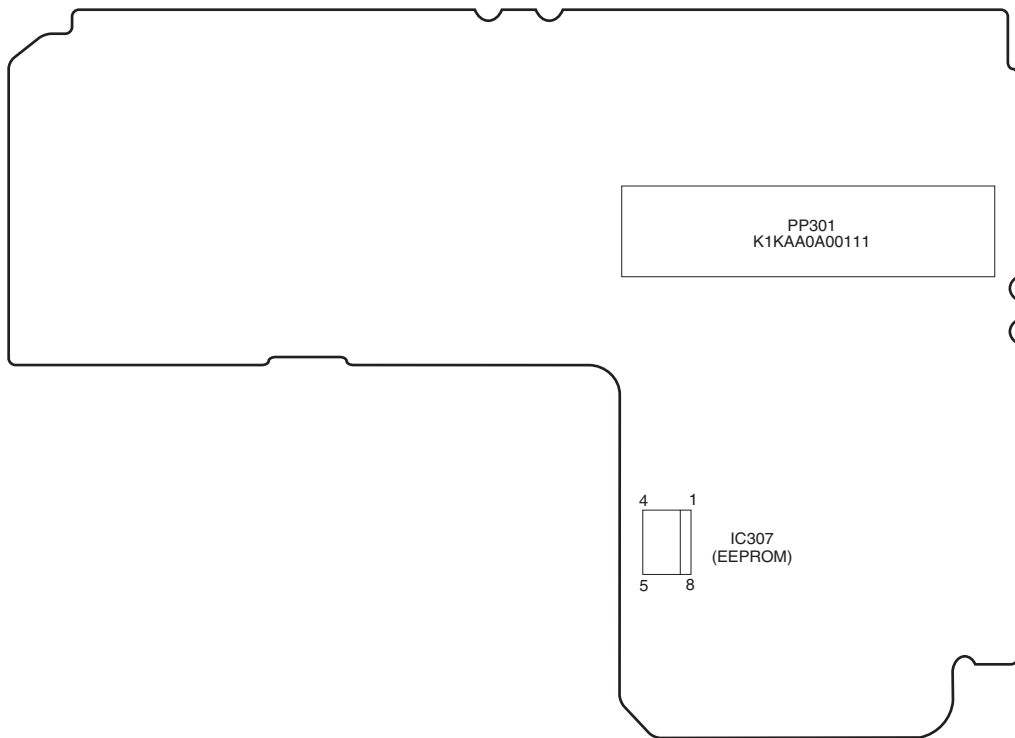

(FOIL SIDE)

9.3. Electrical Adjustment Procedures

9.3.1. Computer assisted adjustment system <TATSUJIN> adjustment

This unit employs the computer assisted system named; [TATSUJIN PC-Adjustment](#) for Electrical adjustment. It is required to install a USB driver for service which can be download only from TSN-WEB.

9.3.2. Set-up manual for DV-Camcorder.

Pay attention, because the adjustment method is different from this machine.

1. Save the software

Install the effective model's TATSUJIN Software to PC: Personal Computer.

2. Set-Up

a. It need the connection between the PC and this unit with USB cable.

b. Connect the PC and DV Camcorder as shown in Fig. E1 and E2.

c. The adjustment instruction is available at [Software download](#) on the [Support Information from NWBG-PAVC](#) web-site in [TSN System](#), together with maintenance software.

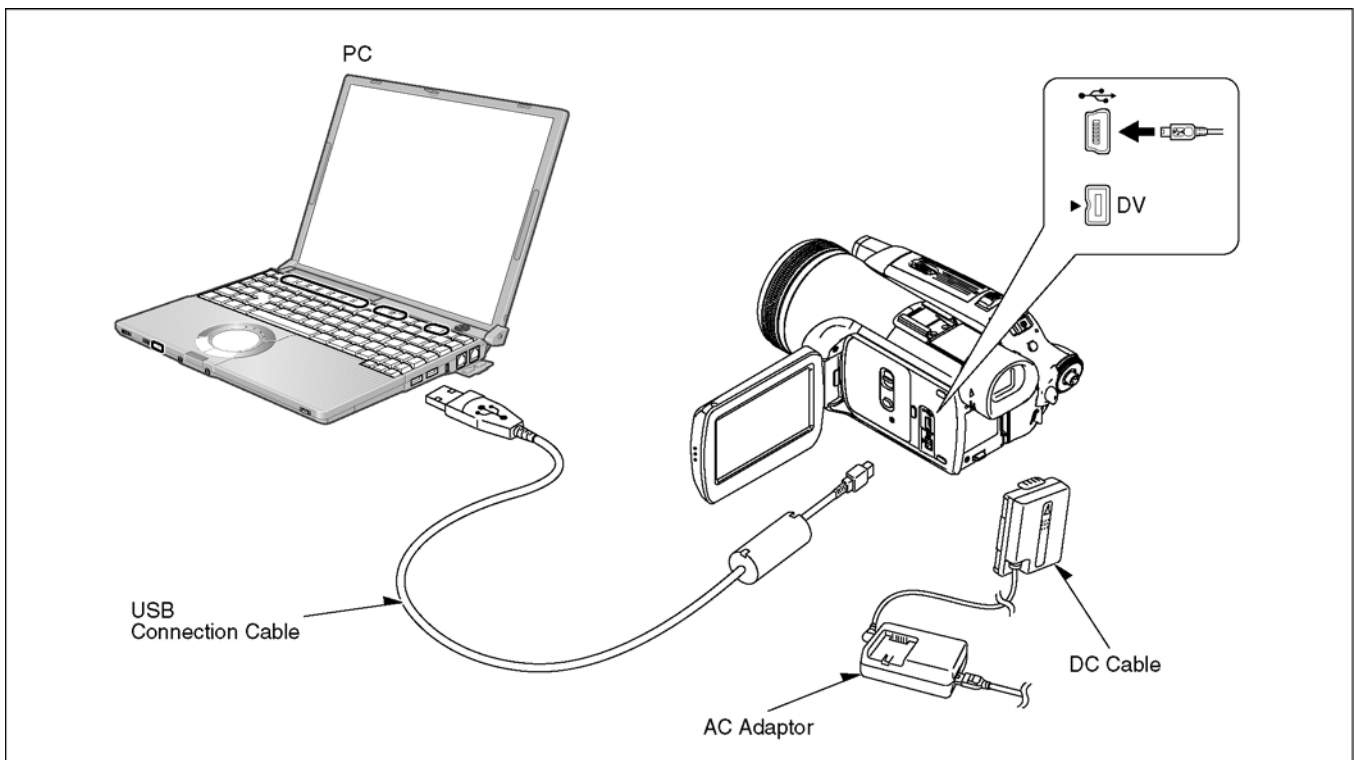

Fig. E1

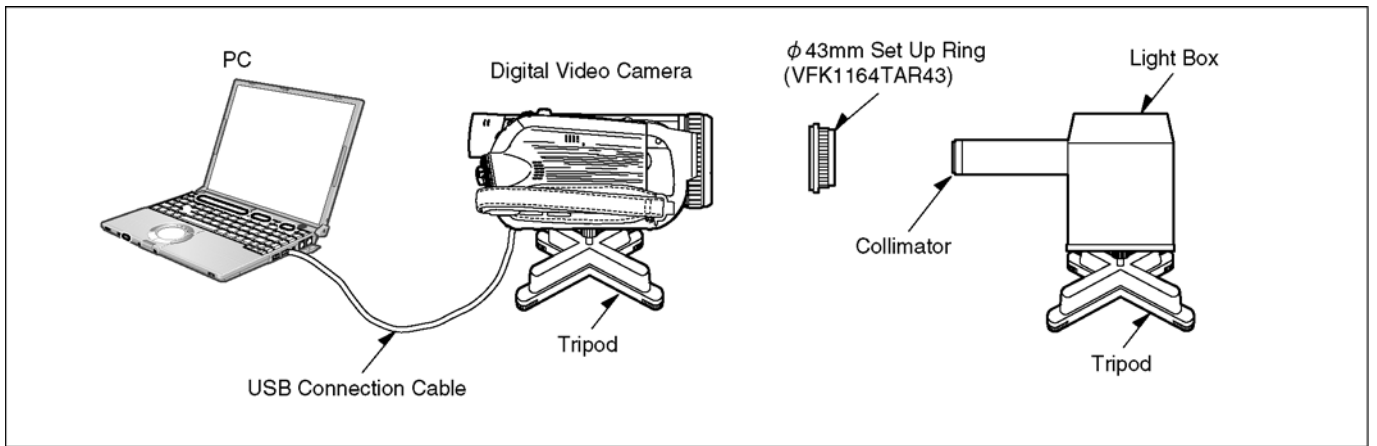

Fig. E2 Rough image of set-up connection

Ref	Name	Parts No.	Q'ty	Remarks
1	DV Camcorder	---	1	The Camcorder being adjusted.
2	Personal Computer	---	1	With Tatsujin Software.
3	AC Adaptor	---	1	The AC Adaptor for DV Camcorder.
4	DC Cable	---	1	The AC Adaptor for DV Camcorder.
5	USB Cable	---	1	Connect the Comcorder and PC.
6	Step Up Ring	VFK1164TAR43	1	For Collimator 43mm
7	TATSUJIN PC-Adjustment Program	VF0D2003AV30	1	

9.3.3. Set up PC-EVR adjustment program

1. Turn on the PC and install the TATSUJIN Adjustment Program into the PC.
2. TATSUJIN PC-Adjustment Program start in the following procedure.
PC Menu : [Start] → [Program] → [win Tatsujin] → [DV Movie] → [NV-GS500 Series]

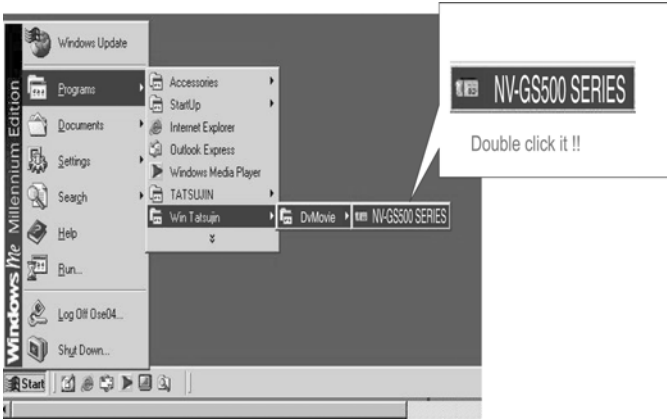
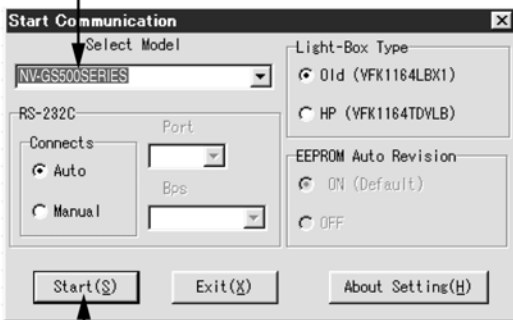

Fig. E3-1

The main menu display will be displayed.

3. Select the desired model.
4. Turn on the camcorder. Then, click **Start**.

① Select the desired model.



② Click to start.

Fig. E3-2

5. The communication is complete, and the dialog will appear.

Then, click **VCR (V) or Cam (C)** to save the EEPROM data,

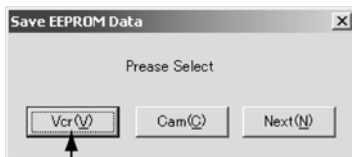

③ Click.

Fig. E3-3

6. Saving for EEPROM data is complete, menu will appear. To perform each adjustment, display the adjustment menu by selecting the desired menu from **Camera Adjust**, **Video Adjust**, **LCD Adjust** or **EVF Adjust** and select each adjustment item.

④ Select the desired menu.

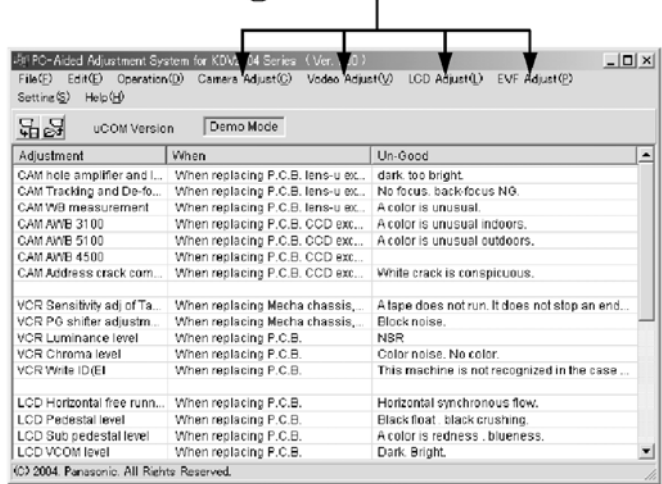

Fig. E3-4

Note:

The adjustment data is stored to the EEPROM IC after each adjustment.

7. After adjustment, to end the software, select **Exit** in File menu or close the window.

⑤ Select "Exit" or close the window.

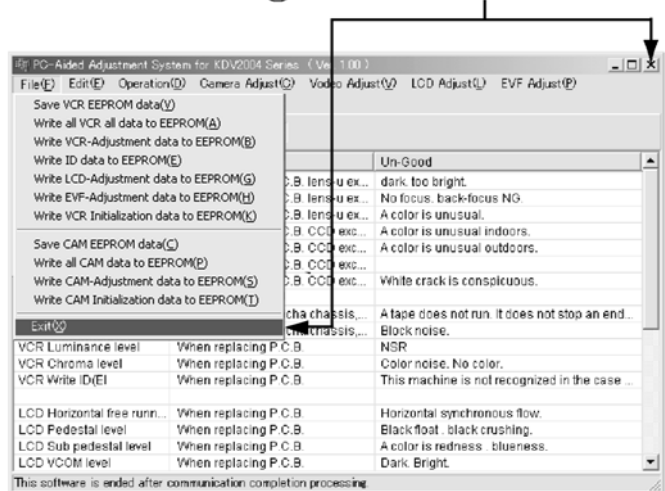

Fig. E3-5

9.3.4. Initial guideline

The table below shows which adjustments are necessary according to the unit parts and individual parts to be replaced. Make sure to perform these adjustments shown below as necessary.

Adjustment Item		Replacement Parts									
		Sub P.C.B.	Main P.C.B.	IC307 (EEPROM)	IC2002 (EEPROM)	Lens Unit	Prism Unit	Iris Unit	4th Lens Frame Unit	Cylinder Unit	Main Chassis Unit
Camera	CAM hole amplifier / Iris PWM	<input type="radio"/>	<input type="radio"/>	<input type="radio"/>	<input type="radio"/>	<input type="radio"/>	<input type="radio"/>	<input type="radio"/>	<input type="radio"/>	<input type="radio"/>	<input type="radio"/>
	CAM Tracking and De-focus	<input type="radio"/>	<input type="radio"/>	<input type="radio"/>	<input type="radio"/>	<input type="radio"/>	<input type="radio"/>	<input type="radio"/>	<input type="radio"/>	<input type="radio"/>	
	CAM Revision CCD scratch	<input type="radio"/>	<input type="radio"/>	<input type="radio"/>	<input type="radio"/>	<input type="radio"/>	<input type="radio"/>	<input type="radio"/>	<input type="radio"/>	<input type="radio"/>	
	CAM AWB adjustment	<input type="radio"/>	<input type="radio"/>	<input type="radio"/>	<input type="radio"/>	<input type="radio"/>	<input type="radio"/>	<input type="radio"/>	<input type="radio"/>	<input type="radio"/>	
Video	VCR Sensitivity ADJ. of Tape sensors	<input type="radio"/>	<input type="radio"/>	<input type="radio"/>	<input type="radio"/>	<input type="radio"/>	<input type="radio"/>	<input type="radio"/>	<input type="radio"/>	<input type="radio"/>	
	VCR PG shifter adjustment	<input type="radio"/>	<input type="radio"/>	<input type="radio"/>	<input type="radio"/>	<input type="radio"/>	<input type="radio"/>	<input type="radio"/>	<input type="radio"/>	<input type="radio"/>	
	VCR Luminance level	<input type="radio"/>	<input type="radio"/>	<input type="radio"/>	<input type="radio"/>	<input type="radio"/>	<input type="radio"/>	<input type="radio"/>	<input type="radio"/>	<input type="radio"/>	

Note : : Adjustment Item

9.4. Mechanical Adjustment Procedures

9.4.1. Adjustment item

Item	Adjustment at the time of the part exchange		
	Half finished goods mechanism	Cylinder	Remarks
Linearity adjustment & BER value confirmation	○	○	

9.4.2. Adjustment procedures

Pay attention, because the adjustment method is different from this machine.

Linearity adjustment & BER value confirmation

1. Remove the mechanism adjustment cover of this machine as shown in Fig. D1.
2. Remove the front case unit. (Refer to Disassembly Procedures.)
3. The envelope detection special tool board (VFK1641) is connected to this machine as shown in Fig. D2 and D3.

Note:

Be careful not to damage when the Passive Probe is connected to the connection terminal of Main P.C.B..
It exists the possibility of the damage.

4. The envelope detection special tool board is connected to oscilloscope as shown in Fig. D2 and D3.
Connect the AV Jack of this machine and the oscilloscope by using the Multi cable.
5. The post is adjusted with the post driver(VFK1899) so that recycles the normal tape which recorded NTSC signal and the detection wave-link become a flat as shown in Fig. D4.
*At the time of the cylinder unit exchange unnecessary.
6. The post is adjusted with the post driver so that recycles a alignment tape(VFM3110EDS) and the detection wave-link become a flat once again.
7. Recycling the tape that video-taped it with this machine after adjustment, the BER value is confirmed with the item of the BER the item of the BER confirmation of expert soft inside.

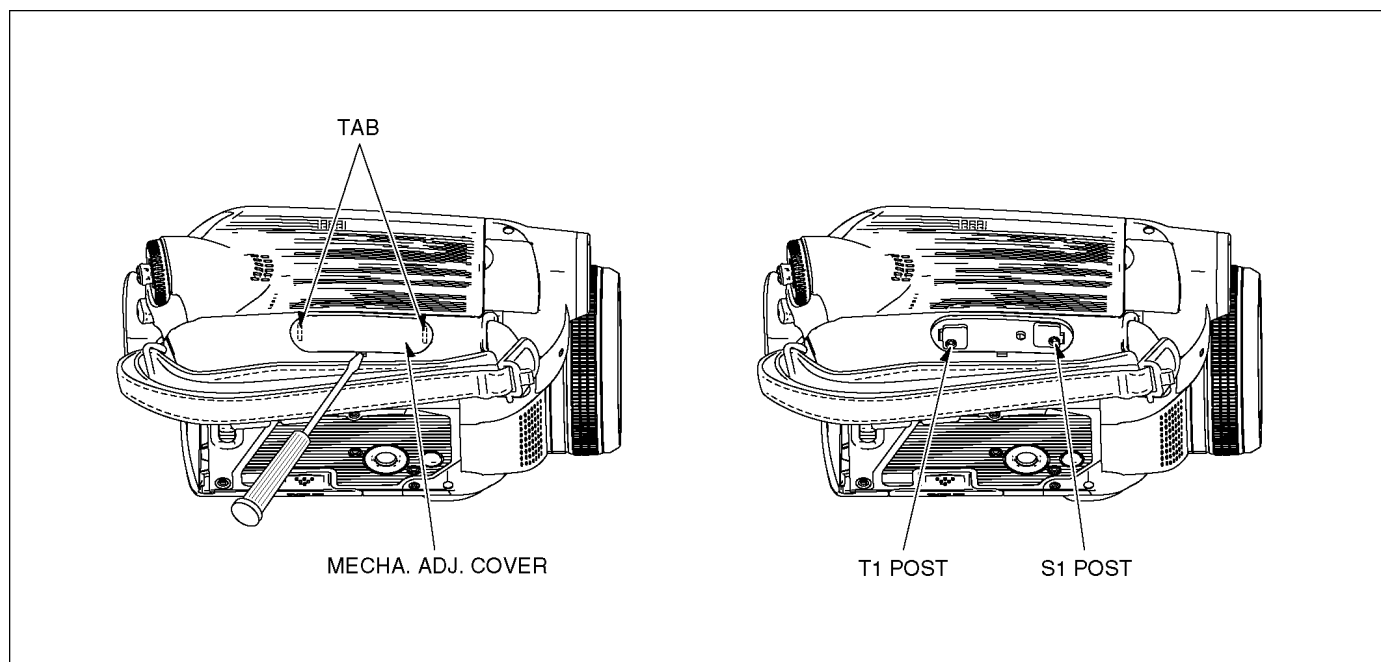

Fig. D1

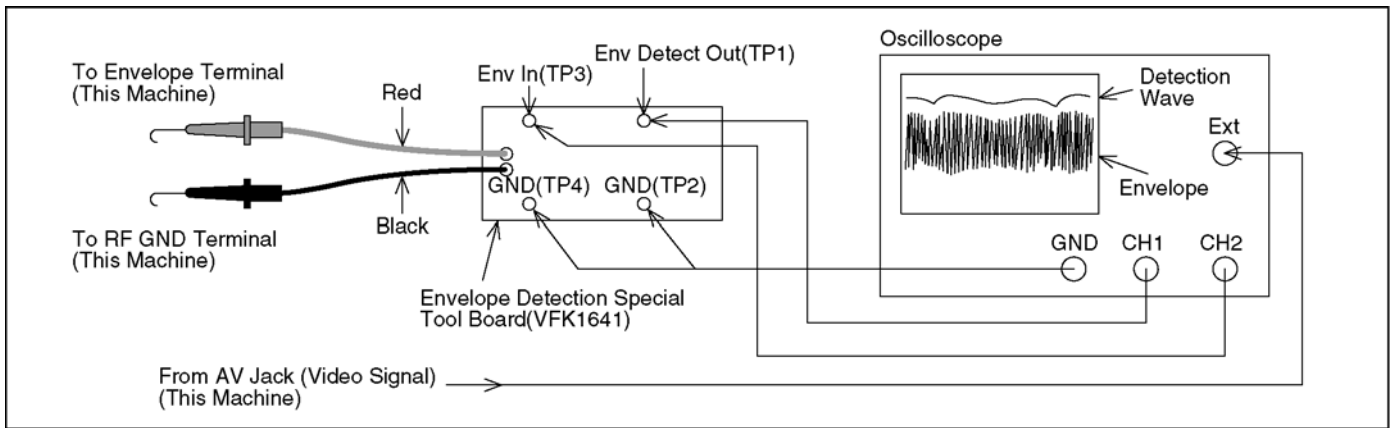

Fig. D2

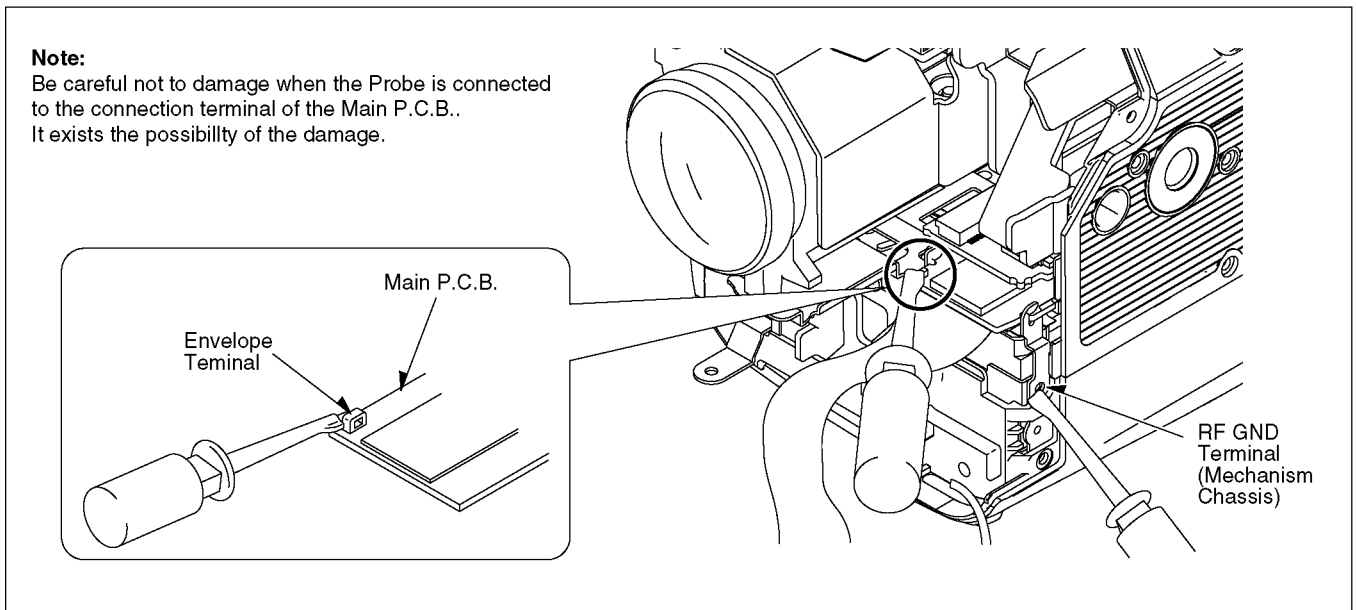

Fig. D3

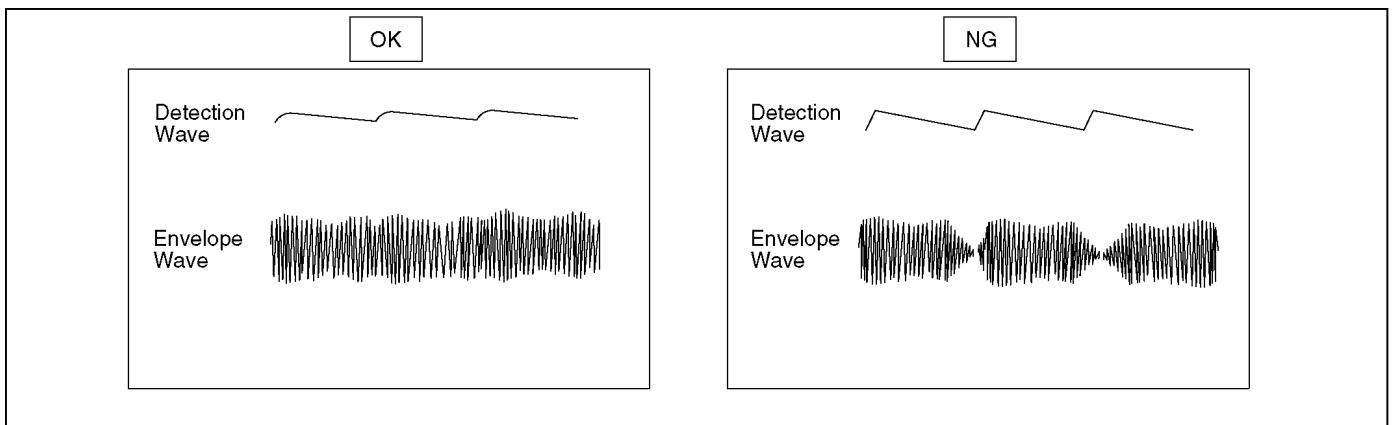

Fig. D4

10 Maintenance

10.1. Cleaning Lens, Viewfinder and LCD Panel

Do not touch the surface of lens, Viewfinder and LCD Panel with your hand.

When cleaning the lens, use air-Blower to blow off the dust.

When cleaning the LCD Panel, dampen the lens cleaning paper with lens cleaner, and the gently wipe the their surface.

Note:

A lens cleaning paper and lens cleaner are available at local camera shops and market place.

Service Manual

Diagrams and Replacement Parts List

Digital Video Camera

- | | |
|------------|-------------|
| NV-GS500EG | NV-GS500GN |
| NV-GS500E | NV-GS500SG |
| NV-GS500EB | NV-GS500GCT |
| NV-GS500EP | NV-GS500PL |
| NV-GS500EE | NV-GS500GT |
| NV-GS500GC | NV-GS508GK |

Vol. 1
 Colour
 (S).....Silver Type

S1. About Indication of The Schematic Diagram

S1.1. Important Safety Notice

COMPONENTS IDENTIFIED WITH THE MARK \triangle HAVE THE SPECIAL CHARACTERISTICS FOR SAFETY. WHEN REPLACING ANY OF THESE COMPONENTS USE ONLY THE SAME TYPE.

1. Although reference number of the parts is indicated on the P.C.B. drawing and/or schematic diagrams, it is NOT mounted on the P.C.B. when it is displayed with "\$" mark.
2. It is only the "Test Round" and no terminal (Pin) is available on the P.C.B. when the TP (Test Point) indicated as "●" mark.
3. The voltage being indicated on the schematic diagram is measured in "Standard-Playback" mode when there is no specify mode is mentioned.
4. Although the voltage and waveform available on here is measured with standard frame, it may be differ from actual measurement due to modification of circuit and so on.
5. The voltage being indicated here may be include observational-error (deviation) due to internal-resistance and/or reactance of equipment. Therefore, handle the value indicated on here as reference.
6. Use the parts number indicated on the Replacement Parts List .
7. Indication on Schematic diagrams:

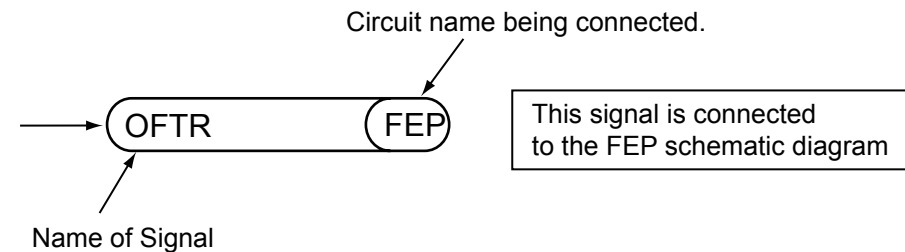

Table of contents

S1. About Indication of The Schematic Diagram.....	S-1	S4.5. Operation (R) Schematic Diagram.....	S-8	S6. Replacement Parts List.....	S-33
S1.1. Important Safety Notice.....	S-1	S4.6. EVF Schematic Diagram.....	S-9	S7. Exploded View	S-42
S2. Voltage and Waveform Chart.....	S-2	S4.7. Front Schematic Diagram	S-10	S7.1. Frame and Casing Section (1)	S-42
S2.1. Side-R P.C.B.	S-2	S4.8. Side-L Schematic Diagram	S-14	S7.2. Frame and Casing Section (2)	S-43
S2.2. EVF P.C.B.	S-2	S4.9. Monitor Schematic Diagram.....	S-15	S7.3. LCD Section.....	S-44
S2.3. Front P.C.B.....	S-2	S4.10. CCD Schematic Diagram.....	S-16	S7.4. Camera Lens Section.....	S-45
S2.4. Monitor P.C.B.	S-2	S5. Print Circuit Board.....	S-20	S7.5. Video Mechanism Section.....	S-46
S2.5. CCD Flex.....	S-2	S5.1. Side-R P.C.B.	S-20	S7.6. Packing Parts and Accessories Section.....	S-47
S3. Block Diagram.....	S-3	S5.1.1. Side-R P.C.B. (Component Side).....	S-20		
S3.1. Overall Block Diagram	S-3	S5.1.2. Side-R P.C.B. (Foil Side).....	S-21		
S4. Schematic Diagram.....	S-4	S5.2. LCD Det P.C.B.	S-22		
S4.1. Interconnection Diagram.....	S-4	S5.3. Operation (R) P.C.B.	S-22		
S4.1.1. Interconnection Diagram (1).....	S-4	S5.4. EVF P.C.B.	S-22		
S4.1.2. Interconnection Diagram (2).....	S-5	S5.5. Front P.C.B.	S-24		
S4.2. Side-R Schematic Diagram.....	S-6	S5.6. Side-L P.C.B.	S-28		
S4.3. LCD Schematic Diagram.....	S-7	S5.7. Monitor P.C.B.	S-29		
S4.4. LCD Det Schematic Diagram.....	S-8	S5.7.1. Monitor P.C.B. (Component Side).....	S-29		
		S5.7.2. Monitor P.C.B. (Foil Side).....	S-30		
		S5.8. CCD Flex.....	S-31		

S2. Voltage and Waveform Chart

Note) Indicated voltage values are the standard values for the unit measured by the DC electronic circuit tester (high-impedance) with the chassis taken as standard. Therefore, there may exist some errors in the voltage values, depending on the internal impedance of the DC circuit tester.

S2.1. Side-R P.C.B.

REF No.	PIN No.	REC	PB	EE
IC601	1	1.2	1.2	1.2
IC601	2	0	0	0
IC601	3	0	0	0
IC601	4	2.8	2.8	2.8
IC601	5	0	0	0
IC601	6	2.8	2.8	2.8
IC601	7	2.8	2.8	2.8
IC601	8	2.8	2.8	2.8
IC601	9	2.8	2.8	2.8
IC601	10	0	0	0
IC601	11	0.9	0.9	0.9
IC601	12	-	-	-
IC601	13	-	-	-
IC601	14	0.3	0.3	0.3
IC601	15	0.2	0.2	0.2
IC601	16	0.3	0.3	0.3
IC601	17	0	0	0
IC601	18	0.2	0.2	0.2
IC601	19	0.3	0.3	0.3
IC601	20	0.3	0.3	0.3
IC601	21	0.3	0.3	0.3
IC601	22	0.3	0.3	0.3
IC601	23	1.8	1.8	1.8
IC601	24	4.8	4.8	4.8
IC601	25	2.5	2.5	2.5
IC601	26	2.5	2.5	2.5
IC601	27	2.5	2.5	2.5
IC601	28	0	0	0
IC601	29	4.5	4.5	4.5
IC601	30	4.3	4.3	4.3
IC601	31	0.7	0.7	0.7
IC601	32	0.4	0.4	0.4
IC601	33	4.8	4.8	4.8
IC601	34	4	4	4
IC601	35	2.2	2.2	2.2
IC601	36	2.6	2.6	2.6
IC601	37	0	0	0
IC601	38	2.8	2.8	2.8
IC601	39	-	-	-
IC601	40	2.8	2.8	2.8
IC601	41	-	-	-
IC601	42	-	-	-
IC601	43	0	0	0
IC601	44	0	0	0
IC601	45	2.8	2.8	2.8
IC601	46	2.8	2.8	2.8
IC601	47	1.4	1.4	1.4
IC601	48	1.3	1.3	1.3
IC601	49	0	0	0
IC601	50	0	0	0
IC601	51	1.4	1.4	1.4
IC601	52	2.8	2.8	2.8
IC601	53	0	0	0
IC601	54	0.1	0.1	0.1
IC601	55	0.1	0.1	0.1
IC601	56	2.8	2.8	2.8
IC601	57	1.4	1.4	1.4
IC601	58	1.4	1.4	1.4
IC601	59	0.1	0.1	0.1
IC601	60	0	0	0
IC601	61	2.2	2.2	2.2
IC601	62	2.2	2.2	2.2
IC601	63	0	0	0
IC601	64	1.2	1.2	1.2
Q601	S	2.3	2.3	2.3
Q601	D	2.3	2.3	2.3
Q601	G	8.4	8.4	8.4
Q602	S	2.3	2.3	2.3
Q602	D	2.3	2.3	2.3
Q602	G	8.4	8.4	8.4
QR601	1	0	0	0
QR601	2	0	0	0
QR601	3	0	0	0
QR601	4	0	0	0
QR601	5	2.8	2.8	2.8
QR601	6	8.4	8.4	8.4

<IC601>



S2.2. EVF P.C.B.

REF No.	PIN No.	REC	PB	EE
Q852	E	0.6	0.6	0.6
Q852	C	1.7	1.7	1.7
Q852	B	1.3	1.3	1.3

S2.3. Front P.C.B.

REF No.	PIN No.	REC	PB	EE
IC481	1	1.3	1.3	1.3
IC481	2	0	0	0
IC481	3	2.9	2.9	2.9
IC481	4	1.2	1.2	1.2
IC482	1	1.3	1.3	1.3
IC482	2	0	0	0
IC482	3	2.9	2.9	2.9
IC482	4	1.2	1.2	1.2
IC4801	1	2.4	2.4	2.4
IC4801	2	2.4	2.4	2.4
IC4801	3	2.4	2.4	2.4
IC4801	4	0	0	0
IC4801	5	2.4	2.4	2.4
IC4801	6	2.4	2.4	2.4
IC4801	7	2.4	2.4	2.4
IC4801	8	4.9	4.9	4.9
IC6701	1	4.2	4.2	4.2
IC6701	2	0	0	0
IC7003	1	0	0	0
IC7003	2	0	0	0
IC7003	3	0	0	0
IC7003	4	0	0	0
IC7003	5	258	246	247
IC7003	6	258	246	247
IC7003	7	258	246	247
IC7003	8	258	246	247
Q491	E	3.7	3.7	3.7
Q491	C	4.9	4.9	4.9
Q491	B	3.4	3.4	3.4
Q492	E	3.2	3.2	3.2
Q492	C	4.9	4.9	4.9
Q492	B	3.7	3.7	3.7
Q4803	E	4.2	4.2	4.2
Q4803	C	4.9	4.9	4.9
Q4803	B	4.8	4.8	4.8
Q4901	E	0	0	0
Q4901	C	0	0	0
Q4901	B	0	0	0
Q4902	E	0	0	0
Q4902	C	0	0	0
Q4902	B	0	0	0
Q4903	E	0	0	0
Q4903	C	0	0	0
Q4903	B	0	0	0
Q4904	E	0	0	0
Q4904	C	0	0	0
Q4904	B	0	0	0
Q4907	E	0	0	0
Q4907	C	0	0	0
Q4907	B	0	0	0
Q4908	E	0	0	0
Q4908	C	0	0	0
Q4908	B	0	0	0
Q7001	E	0	0	0

REF No.	PIN No.	REC	PB	EE
Q7001	C	0	0	0
Q7001	B	0.7	0.7	0.7
Q7002	E	0	0	0
Q7002	C	7.9	7.9	7.9
Q7002	B	0	0	0
Q7003	E	0	0	0
Q7003	C	0	0	0
Q7003	B	0.6	0.6	0.6
Q7004	1	0	0	0
Q7004	2	4.8	4.8	4.8
Q7004	3	0	0	0
Q7004	4	4.9	4.9	4.9
Q7004	5	4.8	4.8	4.8
Q7004	6	0	0	0
QR4901	E	4.8	4.8	4.8
QR4901	C	0	0	0
QR4901	B	4.8	4.8	4.8
QR7001	E	0	0	0
QR7001	C	4.8	4.8	4.8
QR7001	B	0	0	0
QR7008	E	0	0	0
QR7008	C	0.7	0.7	0.7
QR7008	B	0	0	0

S2.4. Monitor P.C.B.

REF No.	PIN No.	REC	PB	EE
Q901	E	1.5	1.5	1.5
Q901	C	0	0	0
Q901	B	1	1	1
Q902	E	0.3	0.3	0.3
Q902	C	1.4	1.4	1.4
Q902	B	1.1	1.1	1.1
Q903	E	0.3	0.3	0.3
Q903	C	1.4	1.4	1.4
Q903	B	1.1	1.1	1.1
Q904	E	0.3	0.3	0.3
Q904	C	1.4	1.4	1.4
Q904	B	1.1	1.1	1.1
Q905	E	0	0	0
Q905	C	0	0	0
Q905	B	0	0	0
Q906	E	0.3	0.3	0.3
Q906	C	1.4	1.4	1.4
Q906	B	1.1	1.1	1.1
Q907	E	0.3	0.3	0.3
Q907	C	1.4	1.4	1.4
Q907	B	1.1	1.1	1.1
Q908	E	0.3	0.3	0.3
Q908	C	1.4	1.4	1.4
Q908	B	1.1	1.1	1.1
Q913	E	1.1	1.1	1.1
Q913	C	0	0	0
Q913	B	0.5	0.5	0.5

S2.5. CCD Flex

REF No.	PIN No.	REC	PB	EE
Q710	1	4.1	4.1	4.1
Q710	2	3.3	3.3	3.3
Q710	3	4.9	4.9	4.9
Q710	4	0	0	0
Q711	1	4.9	4.9	4.9
Q711	2	4.1	4.1	4.1
Q711	3	4.9	4.9	4.9
Q711	4	0	0	0
Q201	E	1.7	1.7	1.7
Q201	C	12	12	12
Q201	B	2.5	2.5	2.5
Q202	E	1.7	1.7	1.7
Q202	C	4.8	4.8	4.8
Q202	B	2.3	2.3	2.3
Q211	E	1.7	1.7	1.7
Q211	C	12	12	12
Q211	B	2.5	2.5	2.5
Q212	E	1.7	1.7	1.7
Q212	C	4.8	4.8	4.8
Q212	B	2.3	2.3	2.3
Q221	E	1.7	1.7	1.7
Q221	C	12	12	12
Q221	B	2.5	2.5	2.5
Q222	E	1.7	1.7	1.7
Q222	C	4.8	4.8	4.8
Q222	B	2.3	2.3	2.3
QR201	E	0	0	0
QR201	C	10	10	10
QR201	B	0	0	0
QR211	E	0	0	0
QR211	C	10	10	10
QR211	B	0	0	0
QR221	E	0	0	0
QR221	C	10	10	10
QR221	B	0	0	0

S3. Block Diagram

S3.1. Overall Block Diagram

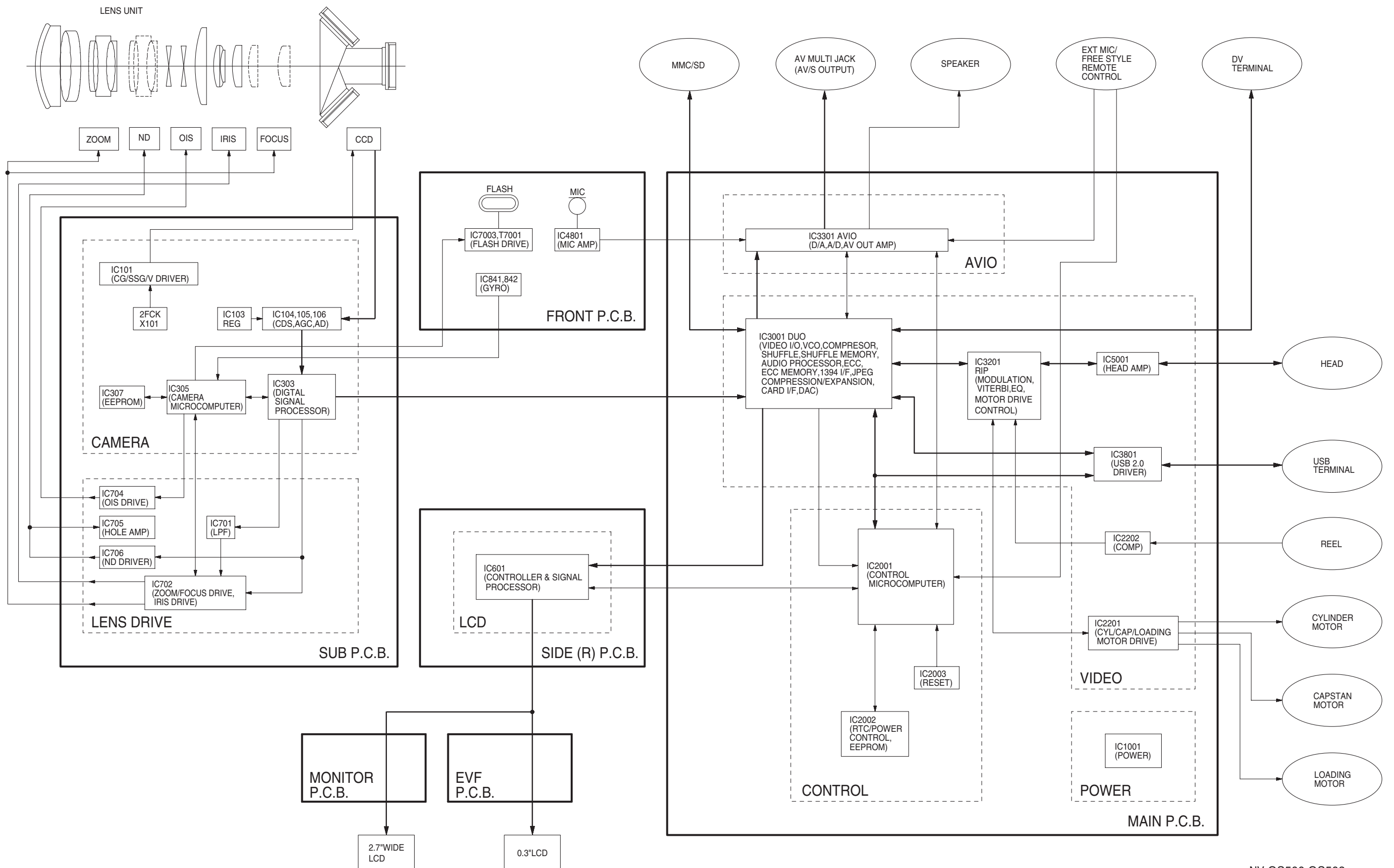

NV-GS500, GS508
OVERALL BLOCK DIAGRAM

S4. Schematic Diagram

S4.1. Interconnection Diagram

S4.1.1. Interconnection Diagram (1)

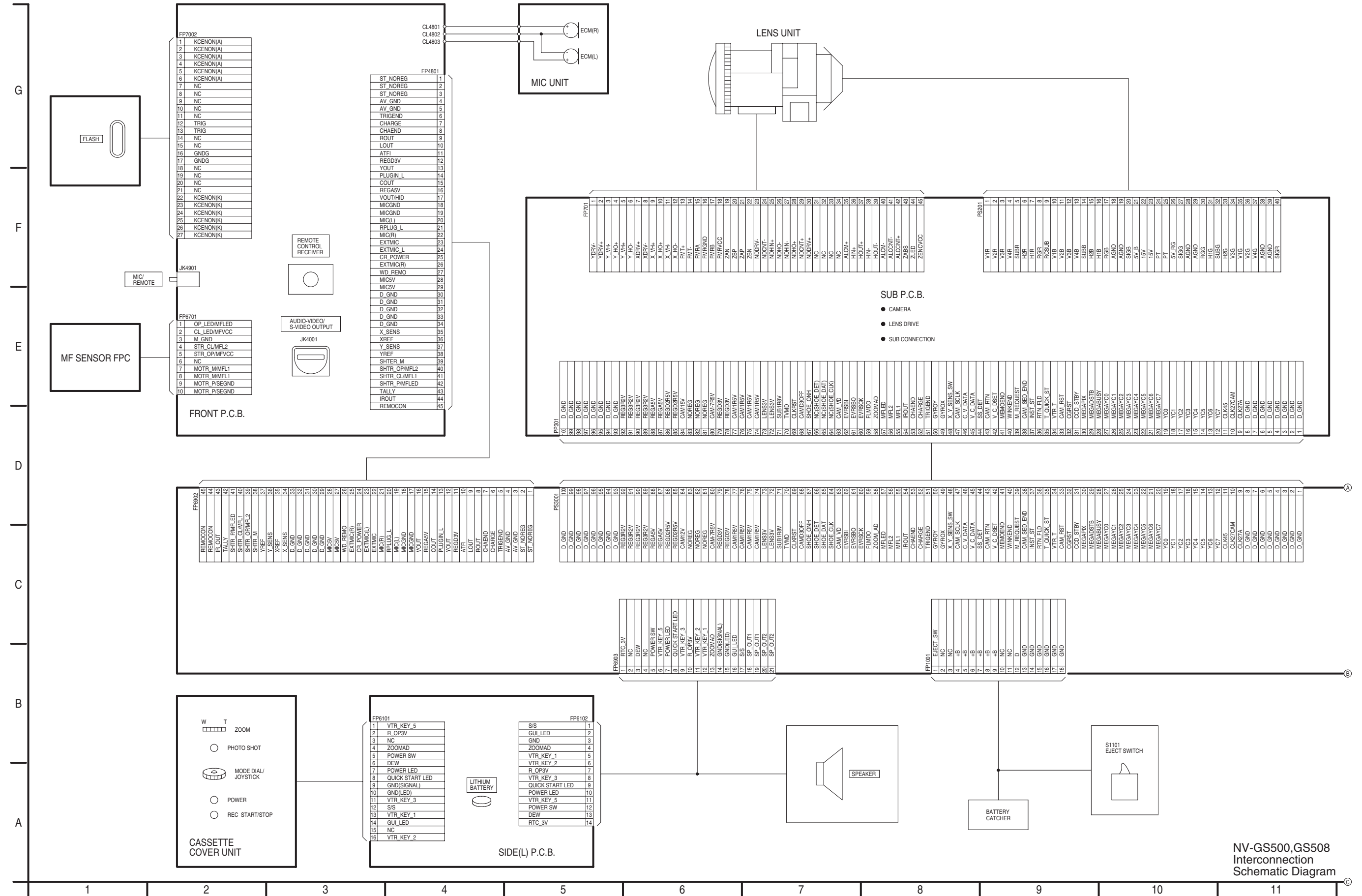

S4.1.2. Interconnection Diagram (2)

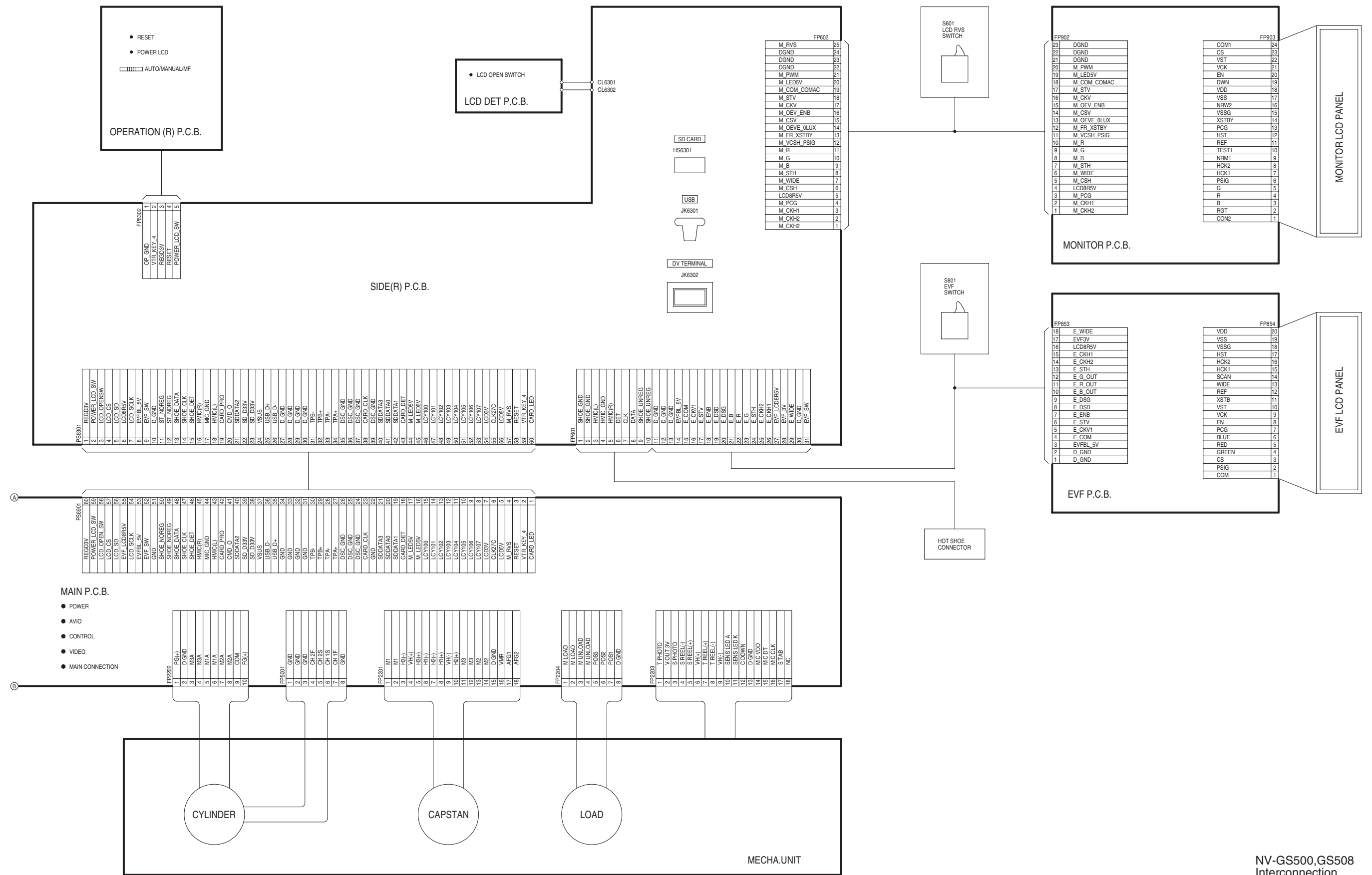

NV-GS500,GS508 Interconnection Schematic Diagram

NV-GS500,GS508 Interconnection Schematic Diagram

S4.2. Side-R Schematic Diagram

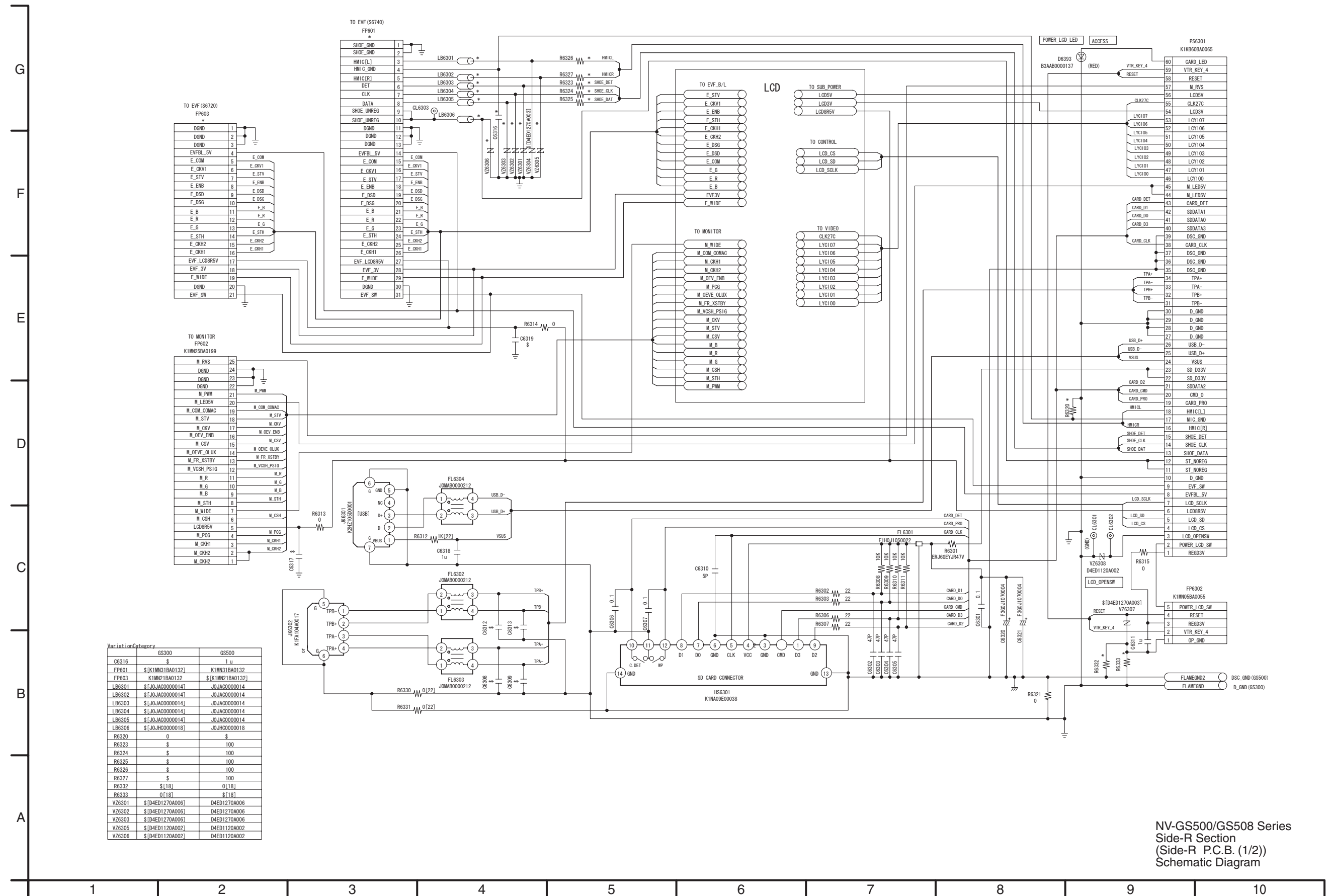

NV-GS500/GS508 Series
Side-R Section
(Side-R P.C.B. (1/2))
Schematic Diagram

S4.3. LCD Schematic Diagram

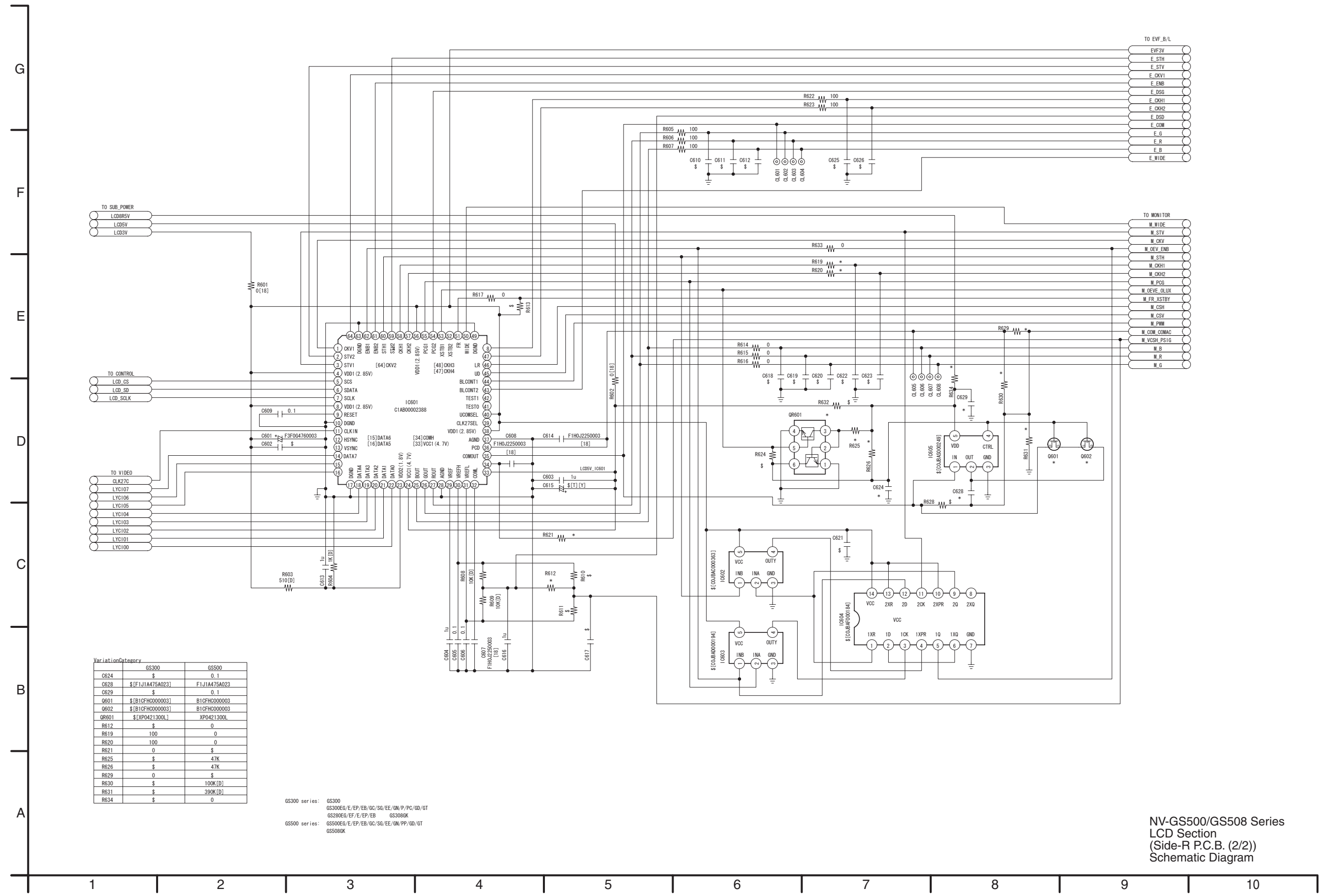

VariationCategory	GS300	GS500
C624	\$	0.1
C628	\$(F1J1A475A023)	F1J1A475A023
C629	\$	0.1
Q601	\$(B1CFH000003)	B1CFH000003
Q602	\$(B1CFH000003)	B1CFH000003
Q601	\$(XP0421300L)	XP0421300L
R612	\$	0
R619	100	0
R620	100	0
R621	0	\$
R625	\$	47K
R626	\$	47K
R629	0	\$
R630	\$	100K[D]
R631	\$	390K[D]
R634	\$	0

GS300 series: GS300
 GS300EG/E/EP/EB/GC/SG/EE/EN/PP/GO/GT
 GS280EG/EF/E/EP/EB GS308K
 GS500 series: GS500EG/E/EP/EB/GC/SG/EE/EN/PP/GO/GT
 GS508K

NV-GS500/GS508 Series
 LCD Section
 (Side-R P.C.B. (2/2))
 Schematic Diagram

S4.4. LCD Det Schematic Diagram / S4.5. Operation (R) Schematic Diagram

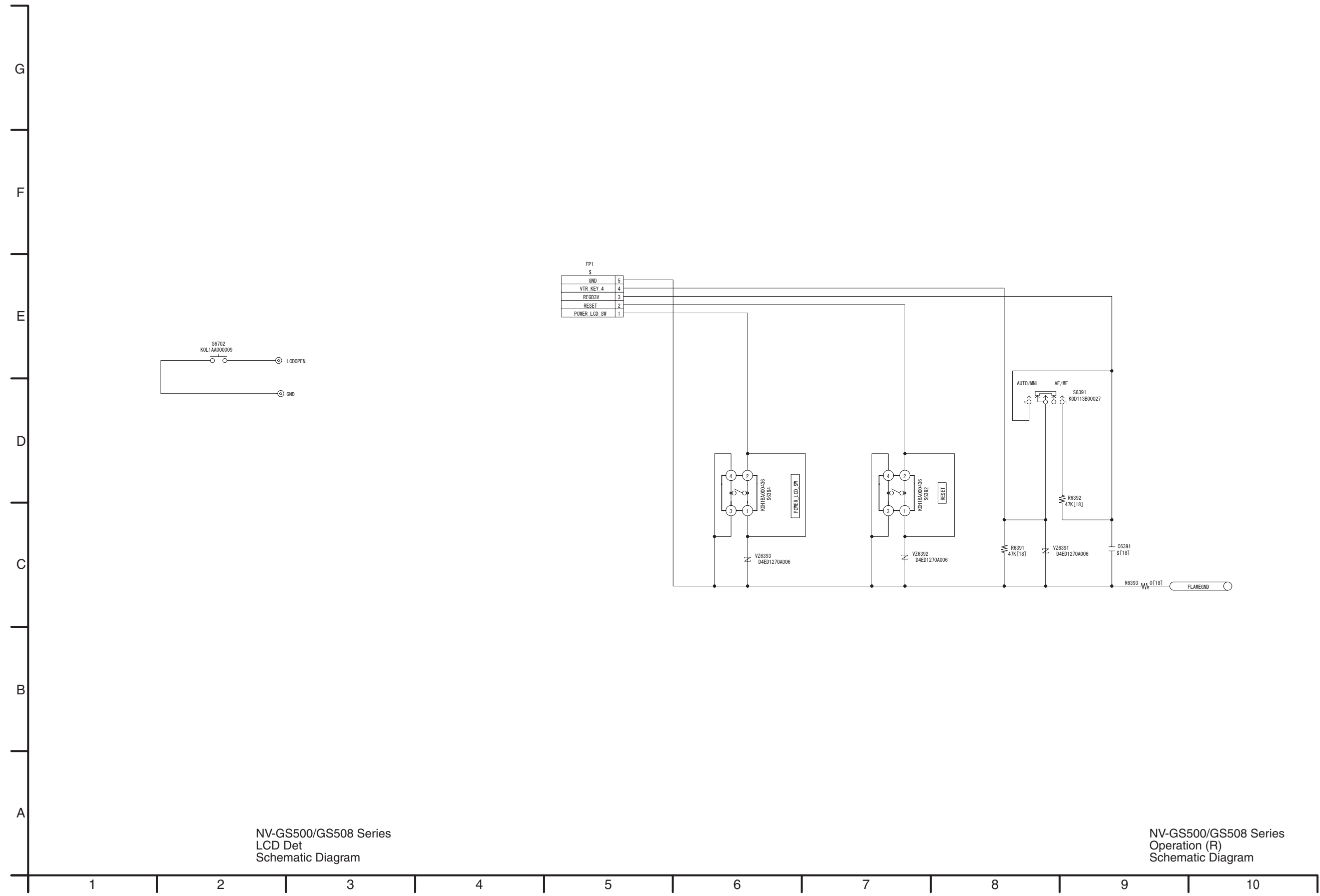

NV-GS500/GS508 Series
LCD Det
Schematic Diagram

NV-GS500/GS508 Series
Operation (R)
Schematic Diagram

S4.6. EVF Schematic Diagram

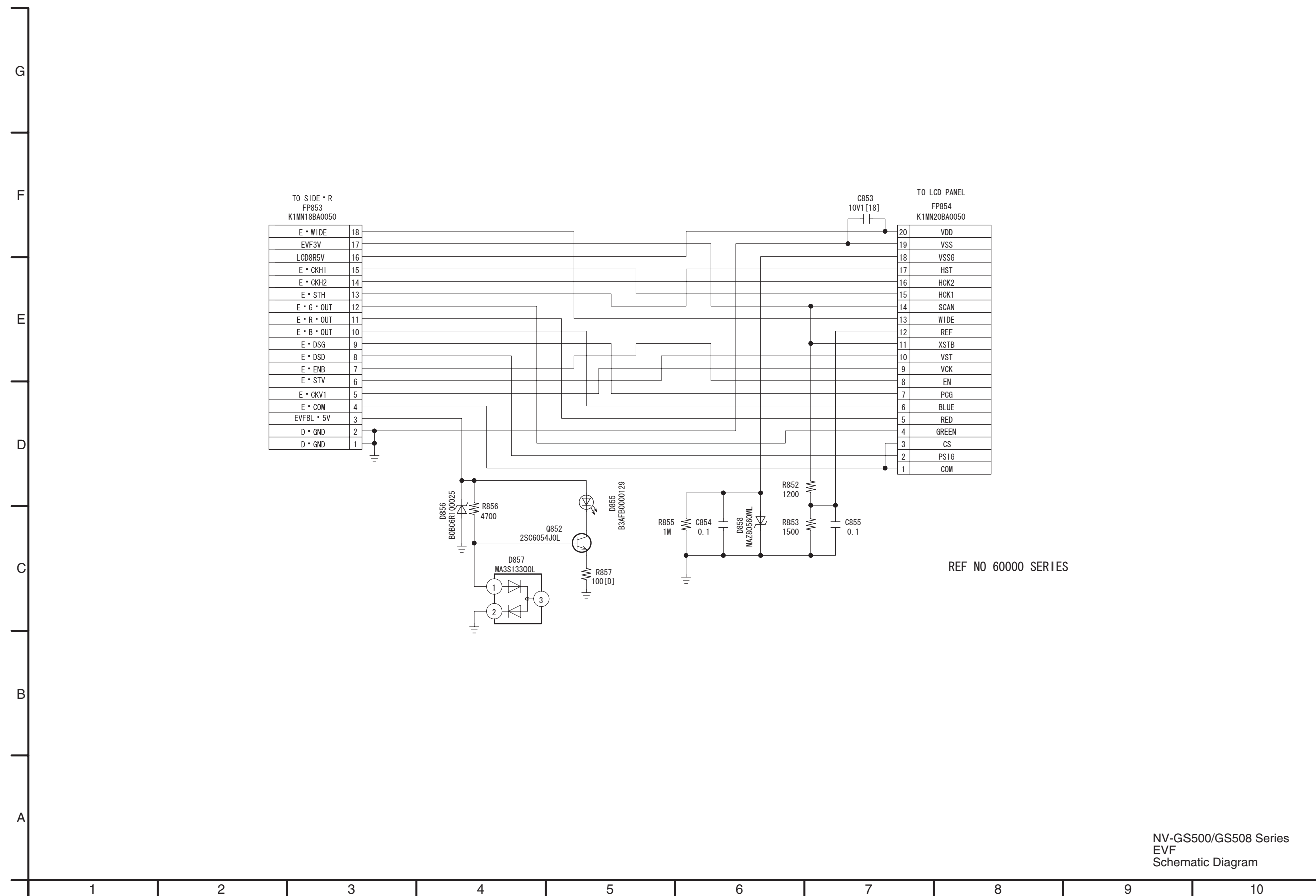

S4.7. Front Schematic Diagram

1/4

NV-GS500/GS508 Series
Front
Schematic Diagram

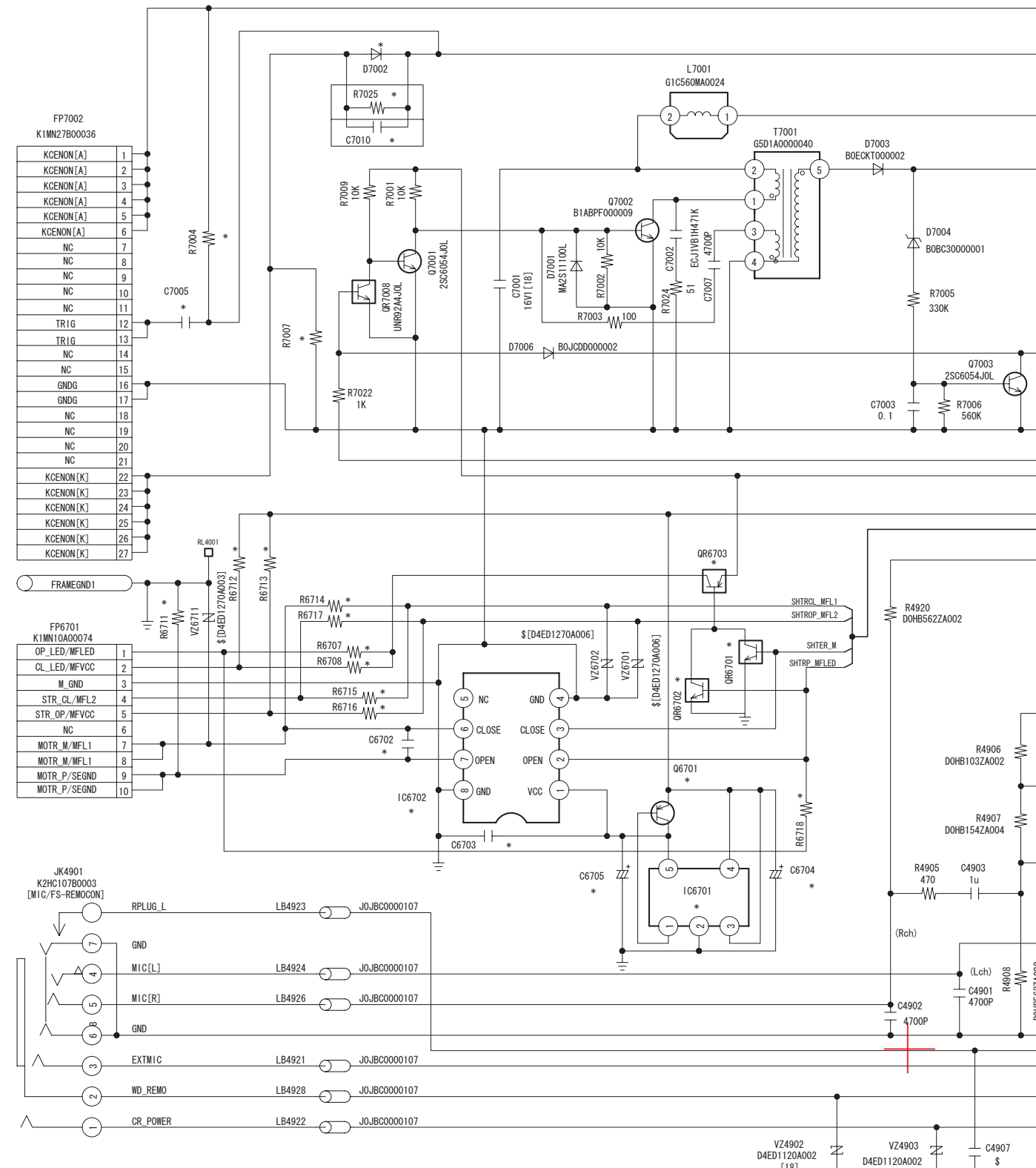

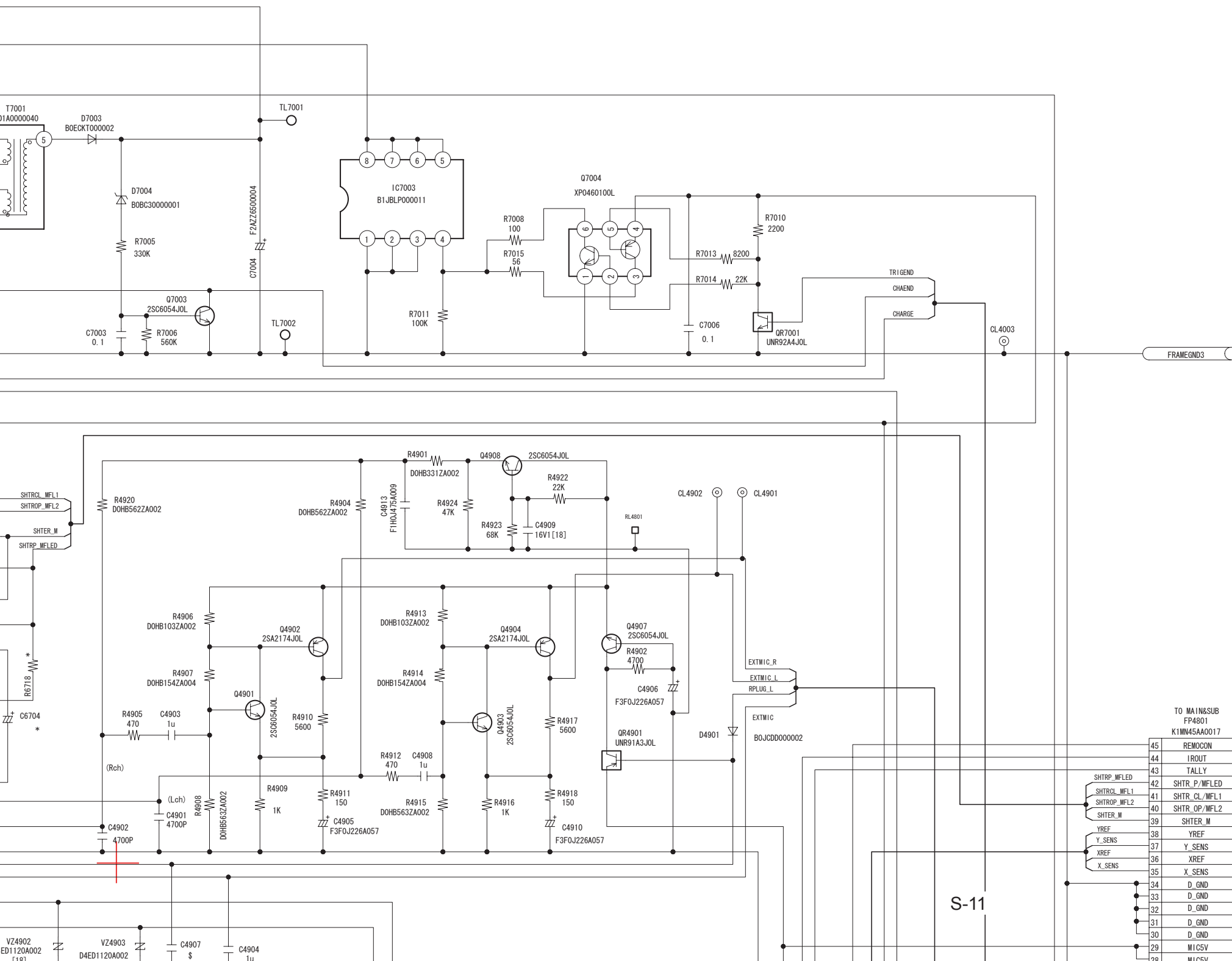

H
G
F
E
D
C
B
A

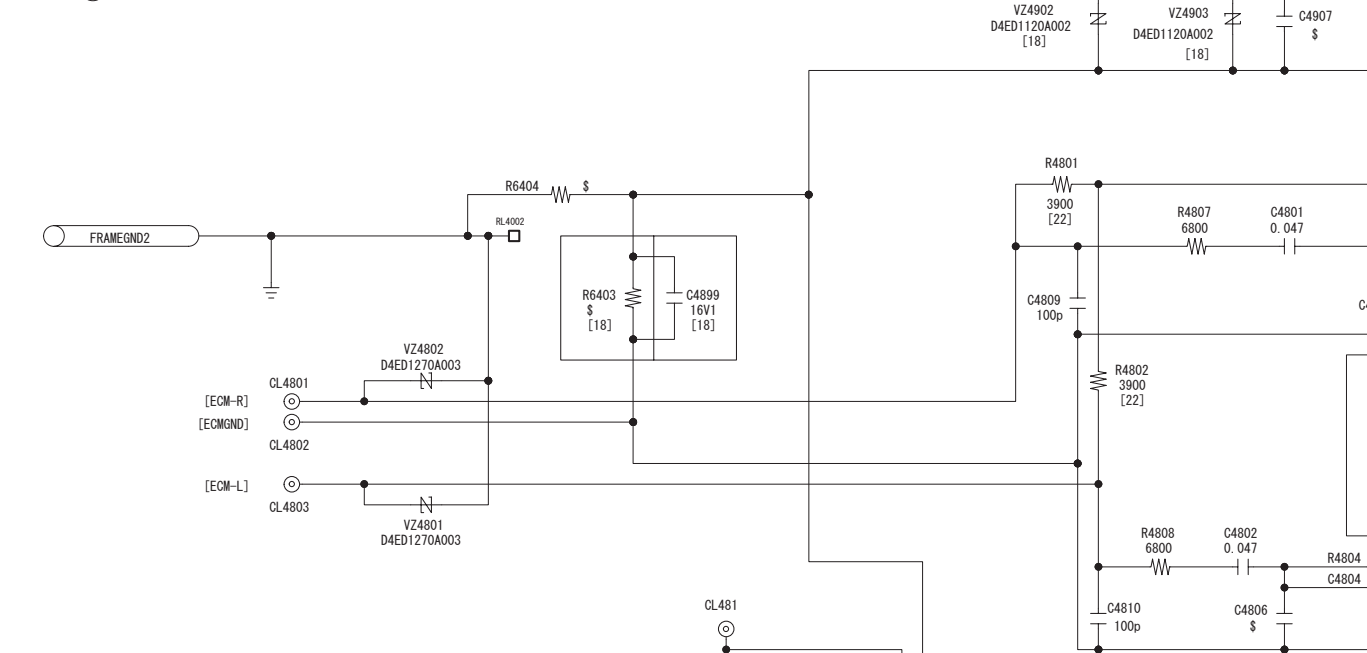
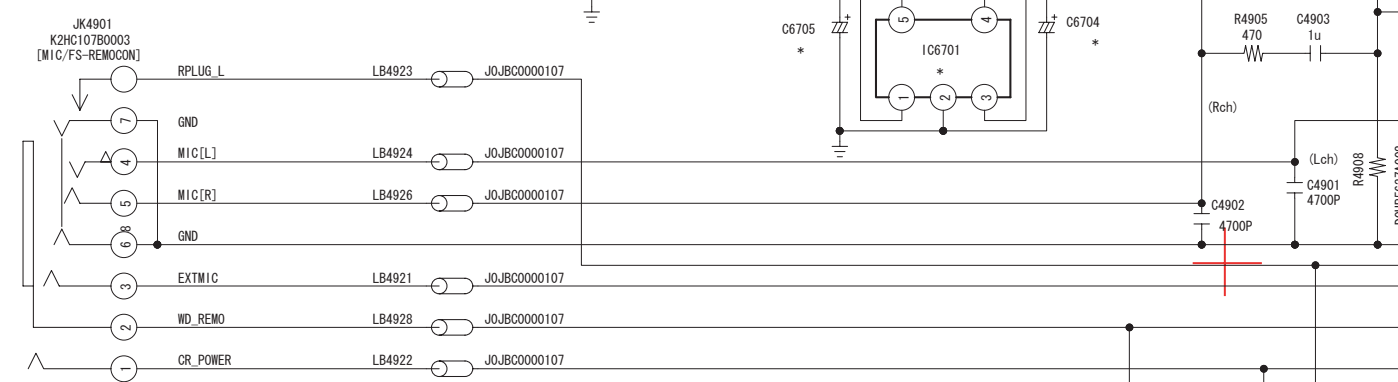

VariationCategory	GS300	GS500
C6702	0.1	\$
C6703	0.1	\$
C6704	F3F0J106A057	\$(F3F0J106A057)
C6705	F3F0J226A057	\$(F3F0J226A057)
C7005	F1K2E4730002	\$
C7010	F1K2E223A004	\$
D7002	BOECKP000024	\$
IC6701	C0DBZGZ00046	\$(C0DBZGZ00046)
IC6702	C0GBF0000024	\$(C0GBF0000024)
Q6701	B1BDB0000005	\$(B1BDB0000005)
QR6701	UNR92A3J0L	\$(UNR92A3J0L)
QR6702	UNR92A3J0L	\$(UNR92A3J0L)
QR6703	UNR91A5J0L	\$(UNR91A5J0L)
R6707	180	\$
R6708	180	\$
R6711	\$	0
R6712	\$	0
R6713	\$	0
R6714	\$	0
R6715	0	\$
R6716	0	\$
R6717	\$	0
R6718	\$	0
R7004	1M[22]	\$(22)
R7007	100K[18]	\$(18)
R7025	\$(36)	0[36]

GS300 series: GS300
 GS300EG/E/EP/EB/GC/SG/EE/GN/P/PC/GD/GT
 GS280EG/EF/E/EP/EB GS308GK
 GS500 series: GS500EG/E/EP/EB/GC/SG/EE/GN/PP/GD/GT
 GS508GK

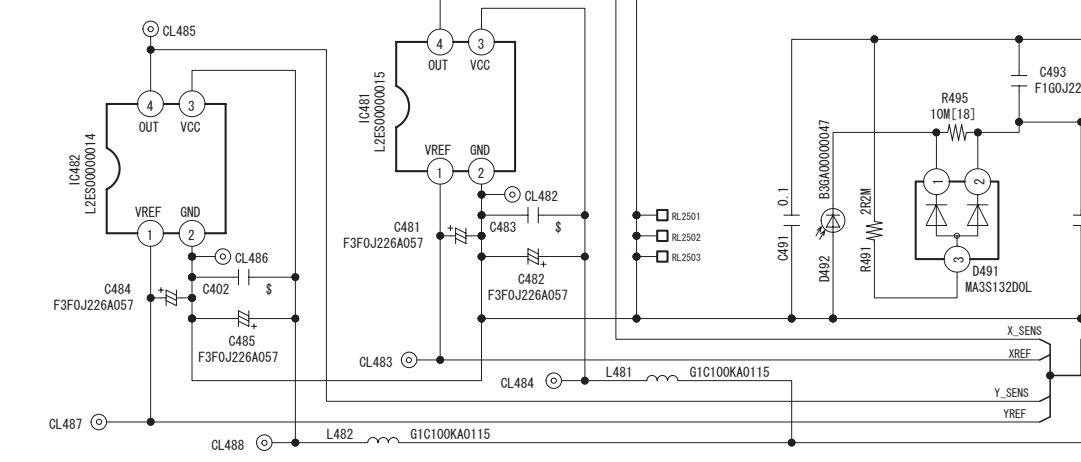

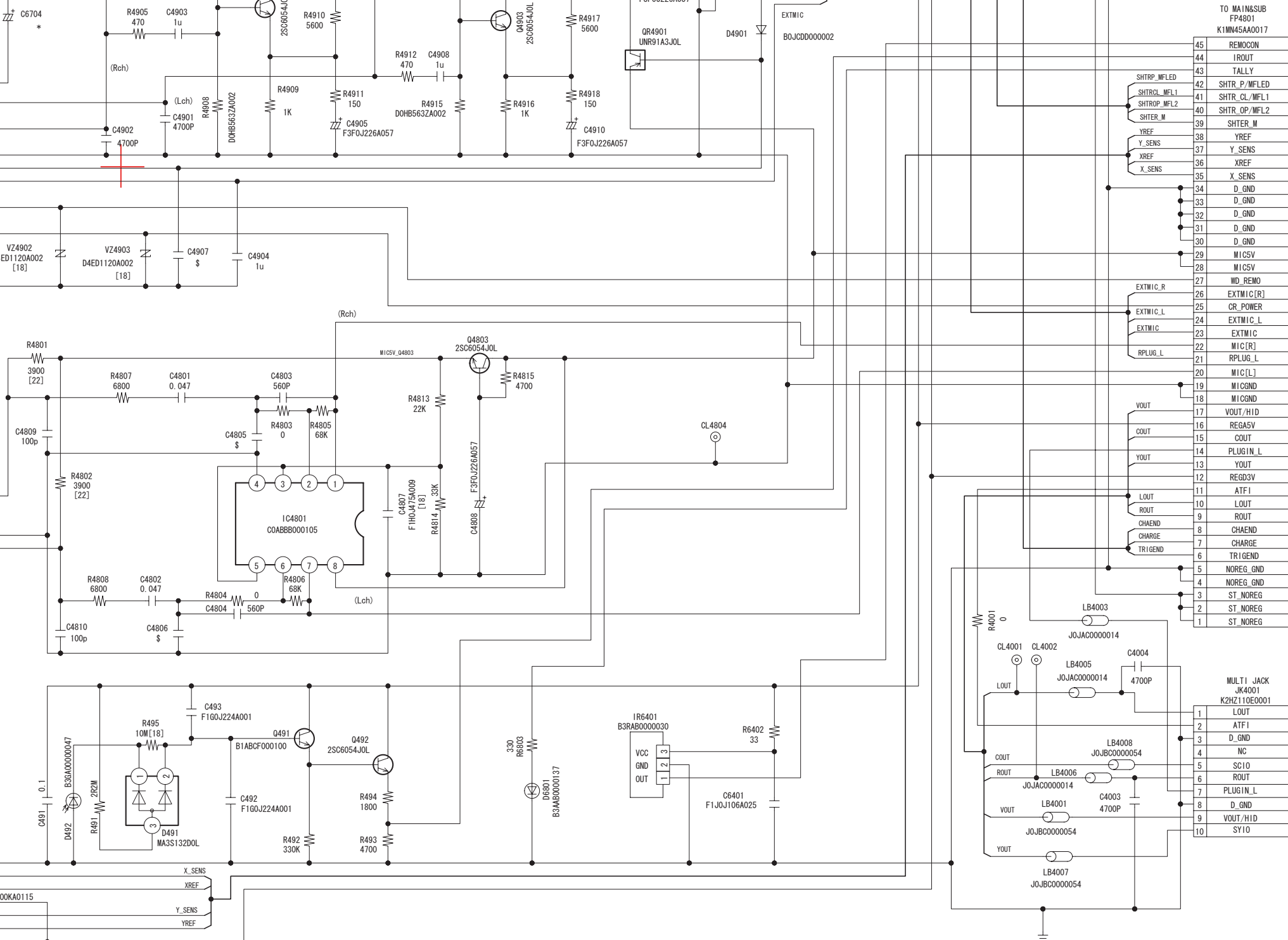

TO MAINSUB
FP4801
K1M45AA0017

45	REMOCON
44	IROUT
43	TALLY
42	SHTR_P/MFLD
41	SHTR_CL/MFL1
40	SHTR_OP/MFL2
39	SHTR_M
38	YREF
37	Y_SENS
36	XREF
35	X_SENS
34	D_GND
33	D_GND
32	D_GND
31	D_GND
30	D_GND
29	MIC5V
28	MIC5V
27	WD_REMO
26	EXTMIC[R]
25	CR_POWER
24	EXTMIC_L
23	EXTMIC
22	MIC[R]
21	RPLUG_L
20	MIC[L]
19	MICGND
18	MICGND
17	VOUT/HID
16	REGA5V
15	COUT
14	PLUGIN_L
13	YOUT
12	REGD3V
11	ATF1
10	LOUT
9	ROUT
8	CHAEND
7	CHARGE
6	TRIGEND
5	NOREG_GND
4	NOREG_GND
3	ST_NOREG
2	ST_NOREG
1	ST_NOREG

MULTI JACK
JK4001
K2HZ110E0001

1	LOUT
2	ATF1
3	D_GND
4	NC
5	SC10
6	ROUT
7	PLUGIN_L
8	D_GND
9	VOUT/HID
10	SY10

S4.8. Side-L Schematic Diagram

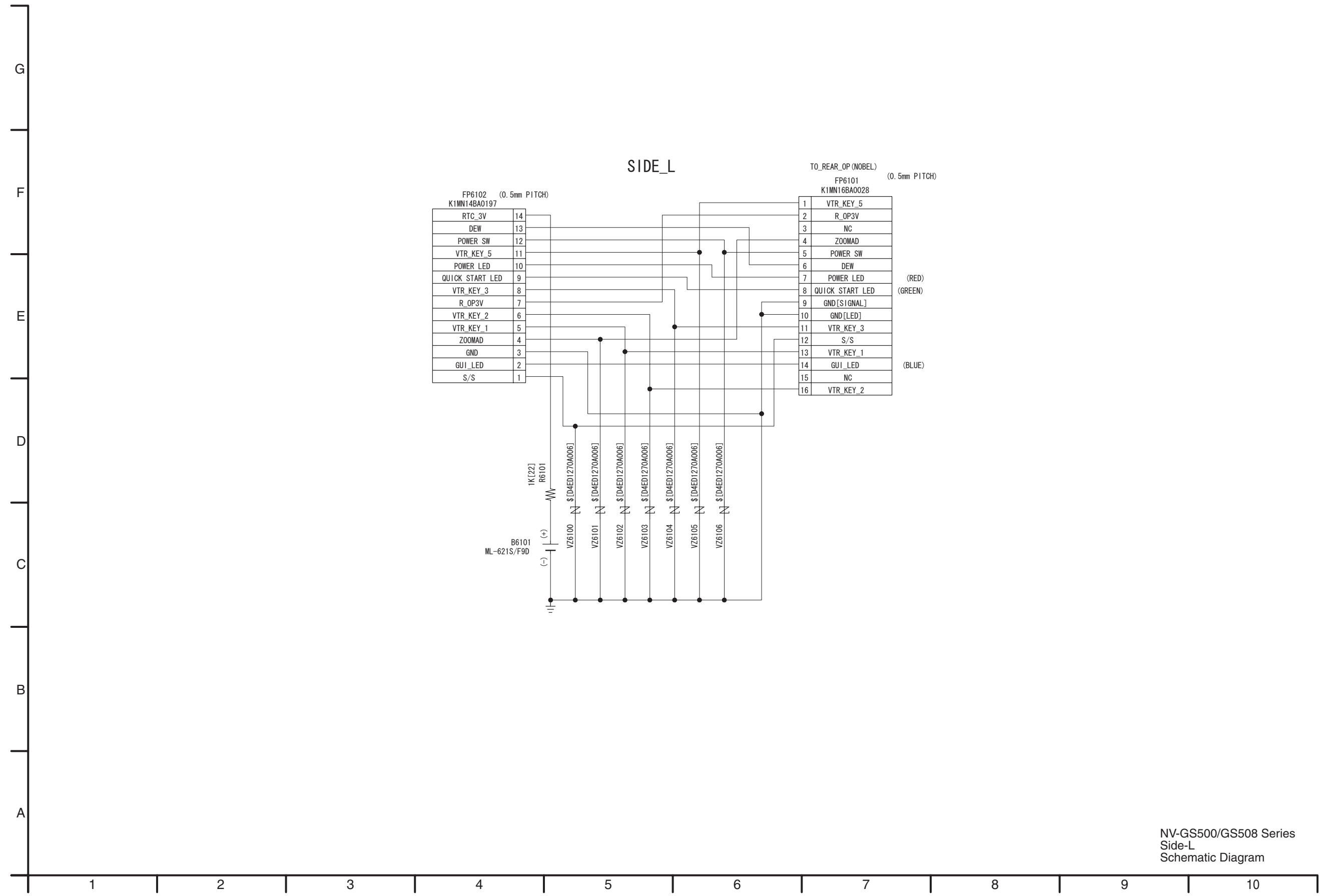

S4.9. Monitor Schematic Diagram

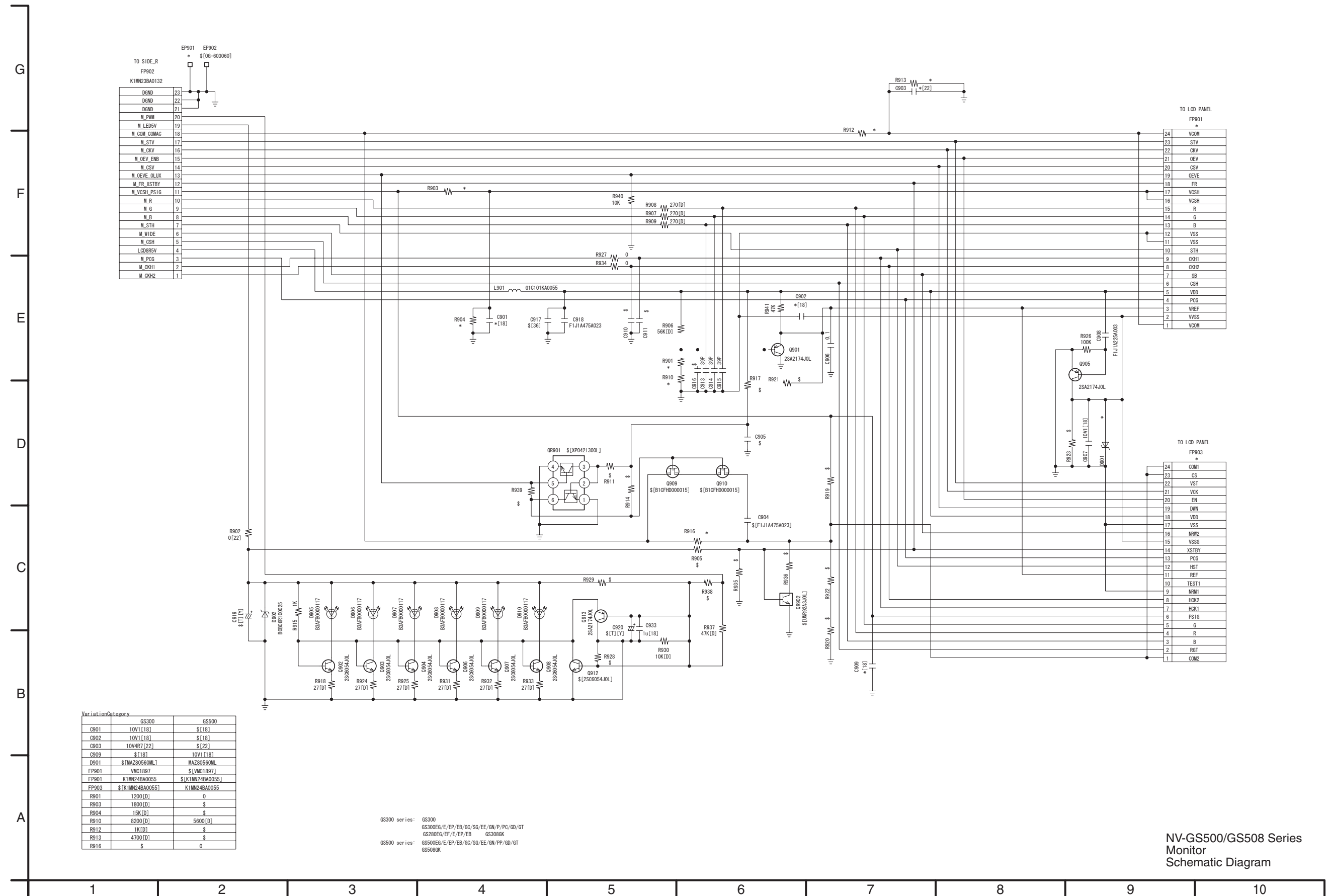

VariationCategory	GS300	GS500
C901	10V1[18]	\$(18)
C902	10V1[18]	\$(18)
C903	10V4R7[22]	\$(22)
C909	\$(18)	10V1[18]
D901	\$(MA280560ML)	MA280560ML
EP901	VMC1897	\$(VMC1897)
FP901	K1MN24BA0055	\$(K1MN24BA0055)
FP903	\$(K1MN24BA0055)	K1MN24BA0055
R901	1200[D]	0
R903	1800[D]	\$
R904	15K[D]	\$
R910	8200[D]	5600[D]
R912	1K[D]	\$
R913	4700[D]	\$
R916	\$	0

GS300 series: GS300
 GS300E/E/EP/EB/GC/SG/EE/EN/PP/QD/GT
 GS280E/E/EP/EB GS308K
 GS500 series: GS500E/E/EP/EB/GC/SG/EE/EN/PP/QD/GT
 GS508K

NV-GS500/GS508 Series
 Monitor
 Schematic Diagram

S4.10. CCD Schematic Diagram

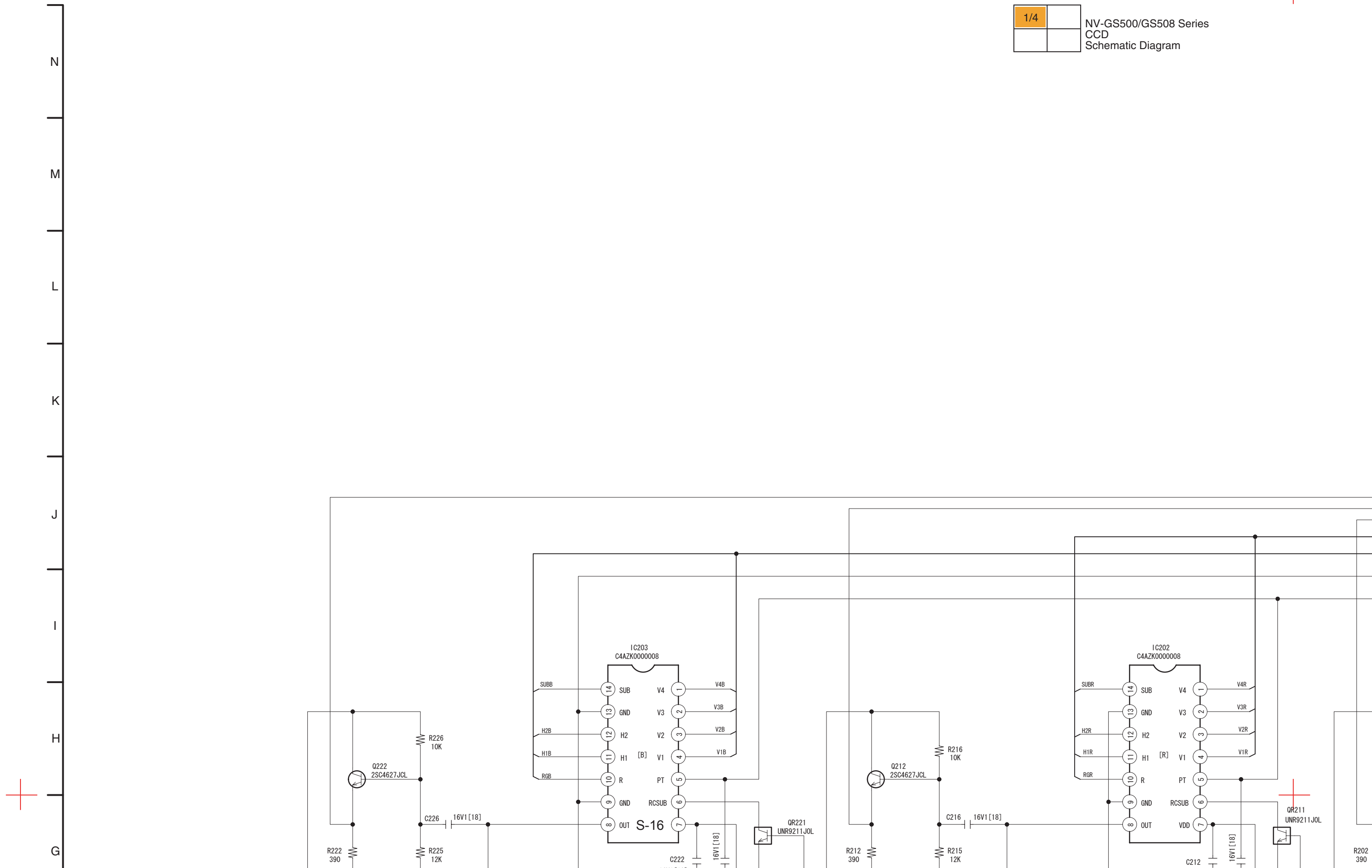

N
M
L
K
J
I
H
G



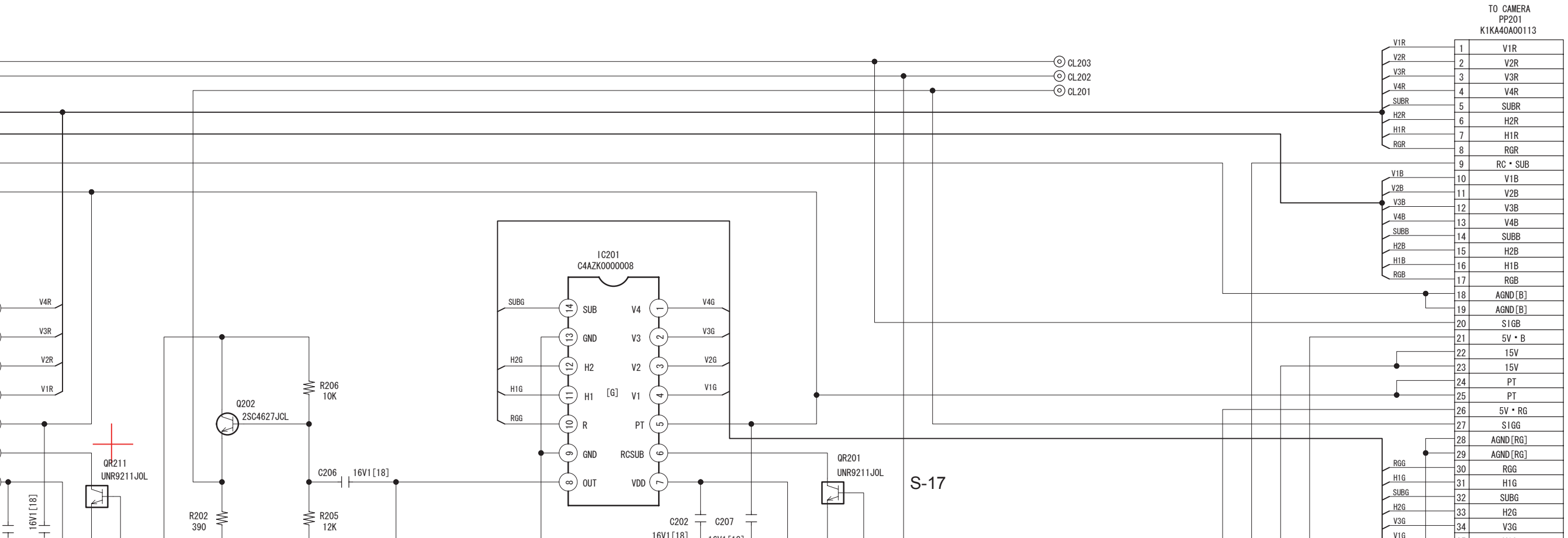

TO CAMERA
PP201
K1KA40A00113

V1R	1	V1R
V2R	2	V2R
V3R	3	V3R
V4R	4	V4R
SUBR	5	SUBR
H2R	6	H2R
H1R	7	H1R
RGR	8	RGR
	9	RC • SUB
V1B	10	V1B
V2B	11	V2B
V3B	12	V3B
V4B	13	V4B
SUBB	14	SUBB
H2B	15	H2B
H1B	16	H1B
RGB	17	RGB
	18	AGND [B]
	19	AGND [B]
	20	S1GB
	21	5V • B
	22	15V
	23	15V
	24	PT
	25	PT
	26	5V • RG
	27	S1GG
	28	AGND [RG]
	29	AGND [RG]
RGG	30	RGG
H1G	31	H1G
SUBG	32	SUBG
H2G	33	H2G
V3G	34	V3G
V1G		



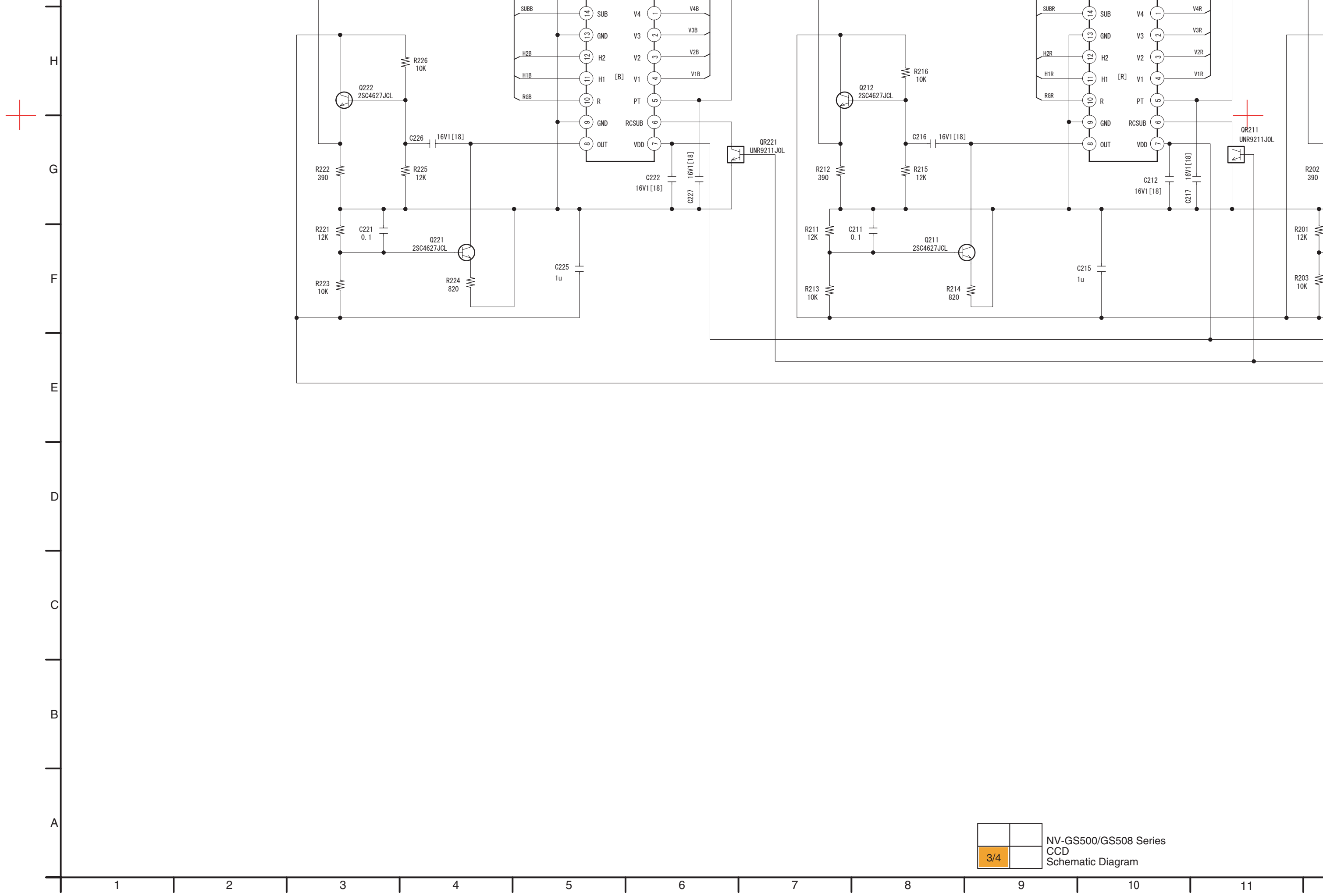

3/4	

 NV-GS500/GS508 Series
 CCD
 Schematic Diagram

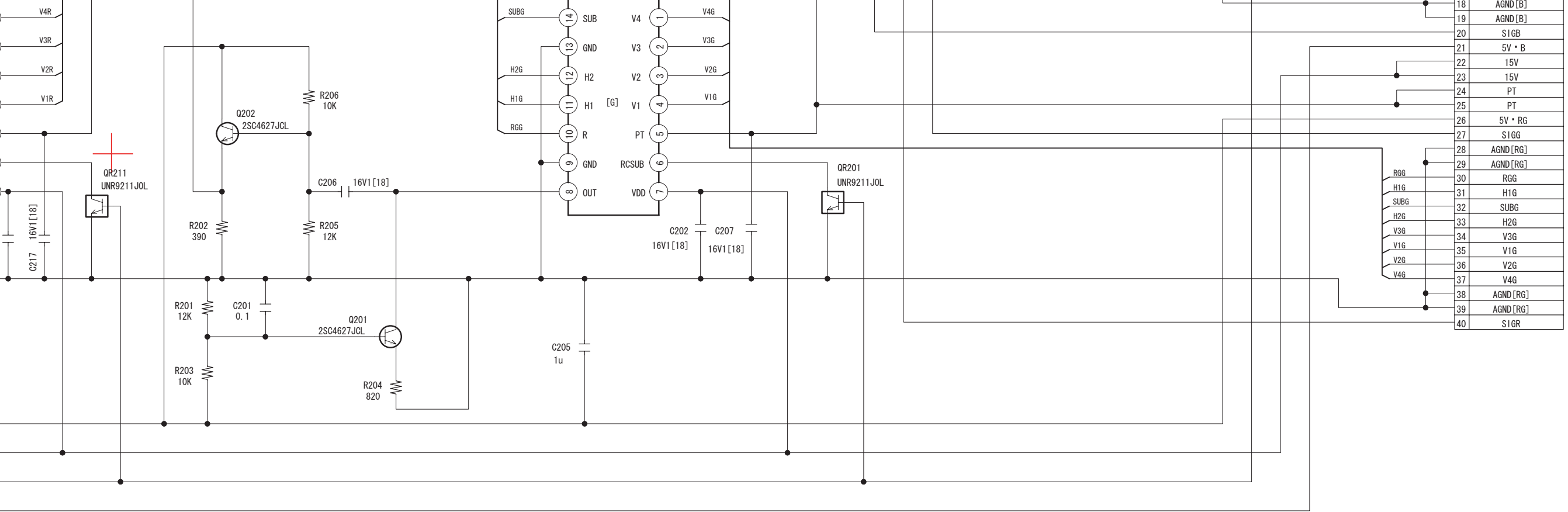

18	AGND [B]
19	AGND [B]
20	S1GB
21	5V • B
22	15V
23	15V
24	PT
25	PT
26	5V • RG
27	S1GG
28	AGND [RG]
29	AGND [RG]
30	RGG
31	H1G
32	SUBG
33	H2G
34	V3G
35	V1G
36	V2G
37	V4G
38	AGND [RG]
39	AGND [RG]
40	S1GR

S5. Print Circuit Board

S5.1. Side-R P.C.B.

S5.1.1. Side-R P.C.B. (Component Side)

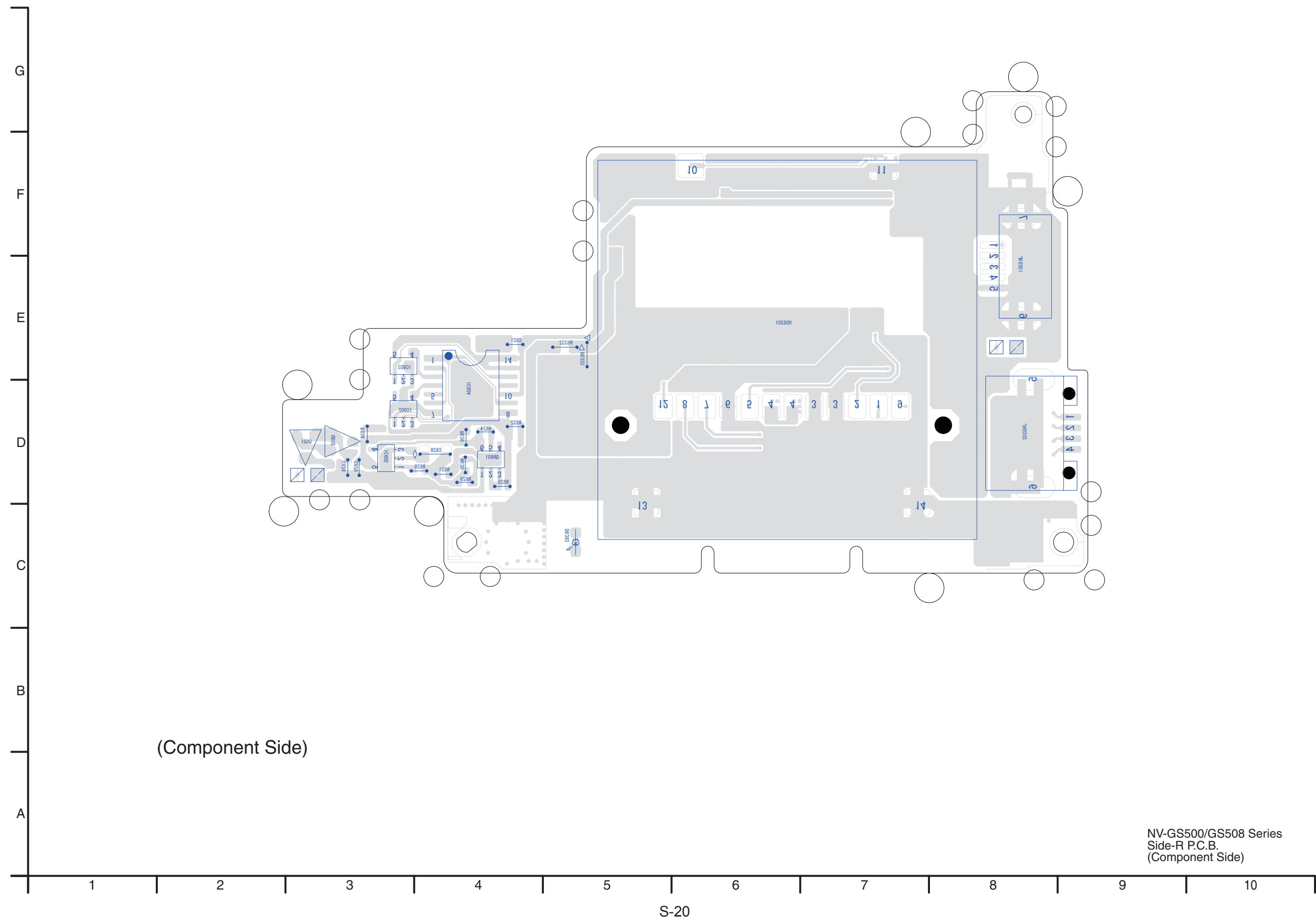

NV-GS500/GS508 Series
Side-R P.C.B.
(Component Side)

S5.1.2. Side-R P.C.B. (Foil Side)

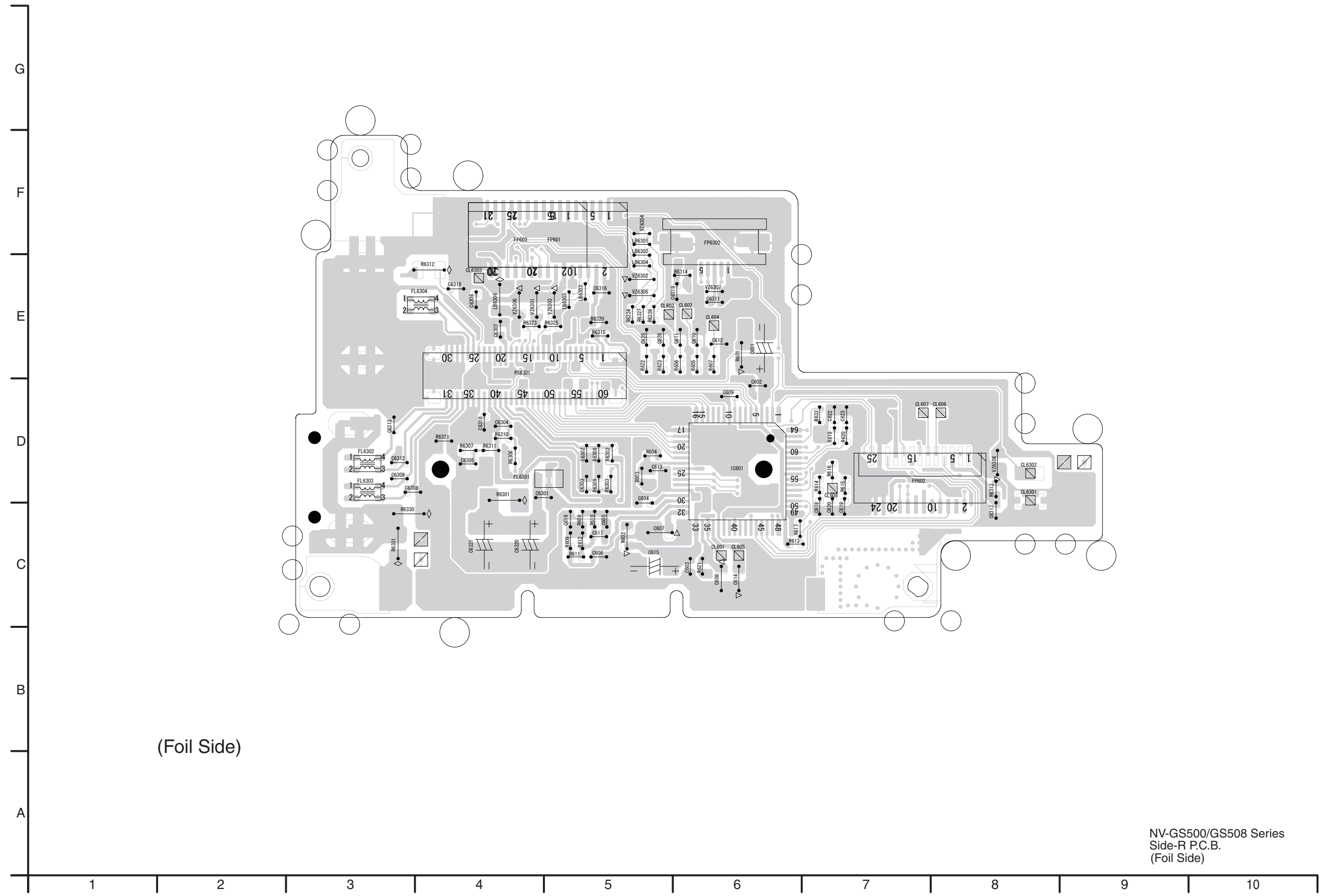

(Foil Side)

NV-GS500/GS508 Series
Side-R P.C.B.
(Foil Side)

S5.2. LCD Det P.C.B. / S5.3. Operation (R) P.C.B. / S5.4. EVF P.C.B.

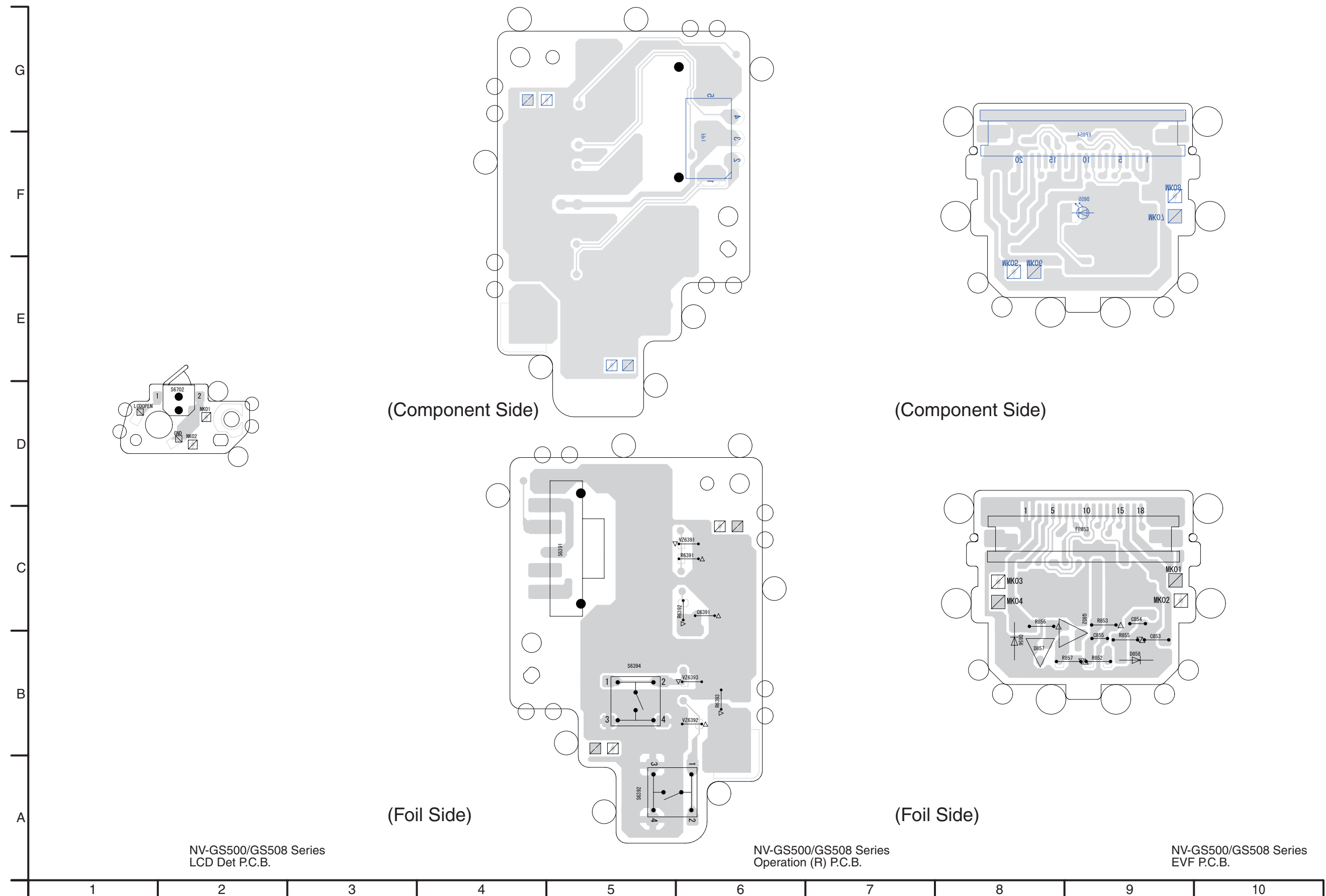

NV-GS500/GS508 Series
LCD Det P.C.B.

NV-GS500/GS508 Series
Operation (R) P.C.B.

NV-GS500/GS508 Series
EVF P.C.B.

S5.5. Front P.C.B.

1/4	

NV-GS500/GS508 Series
Front P.C.B.
(Component Side)

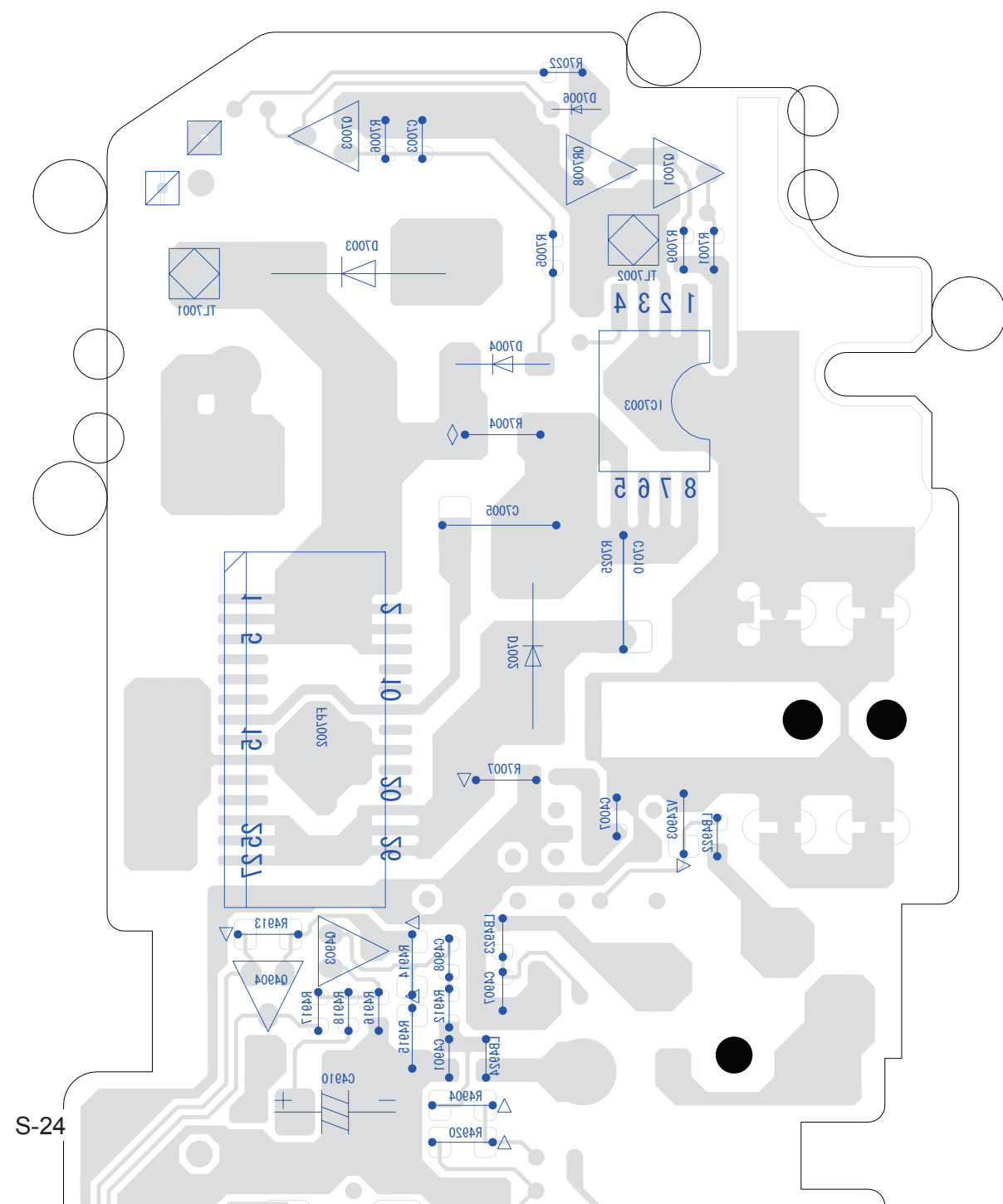

N
M
L
K
J
I
H
G

S-24

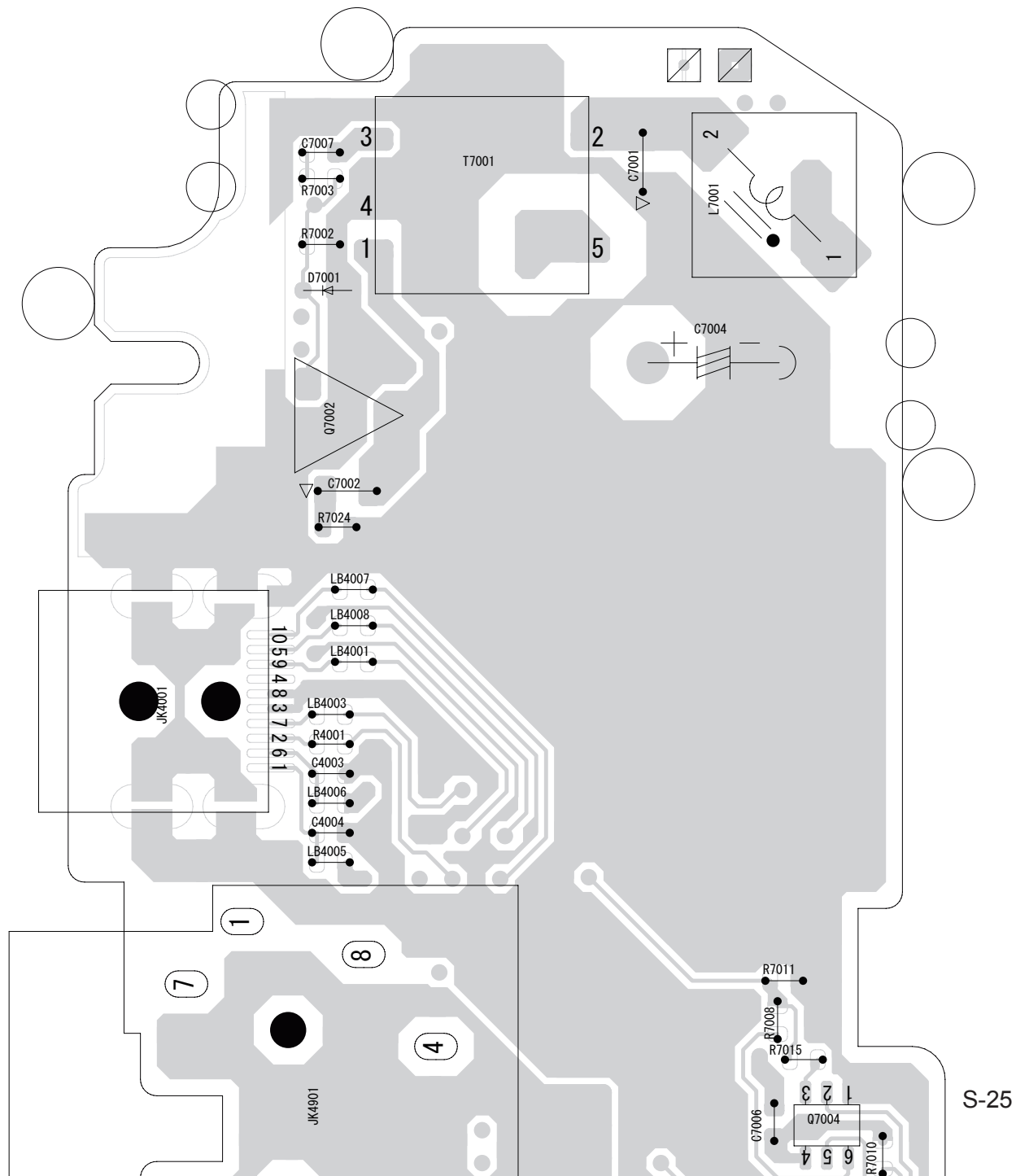

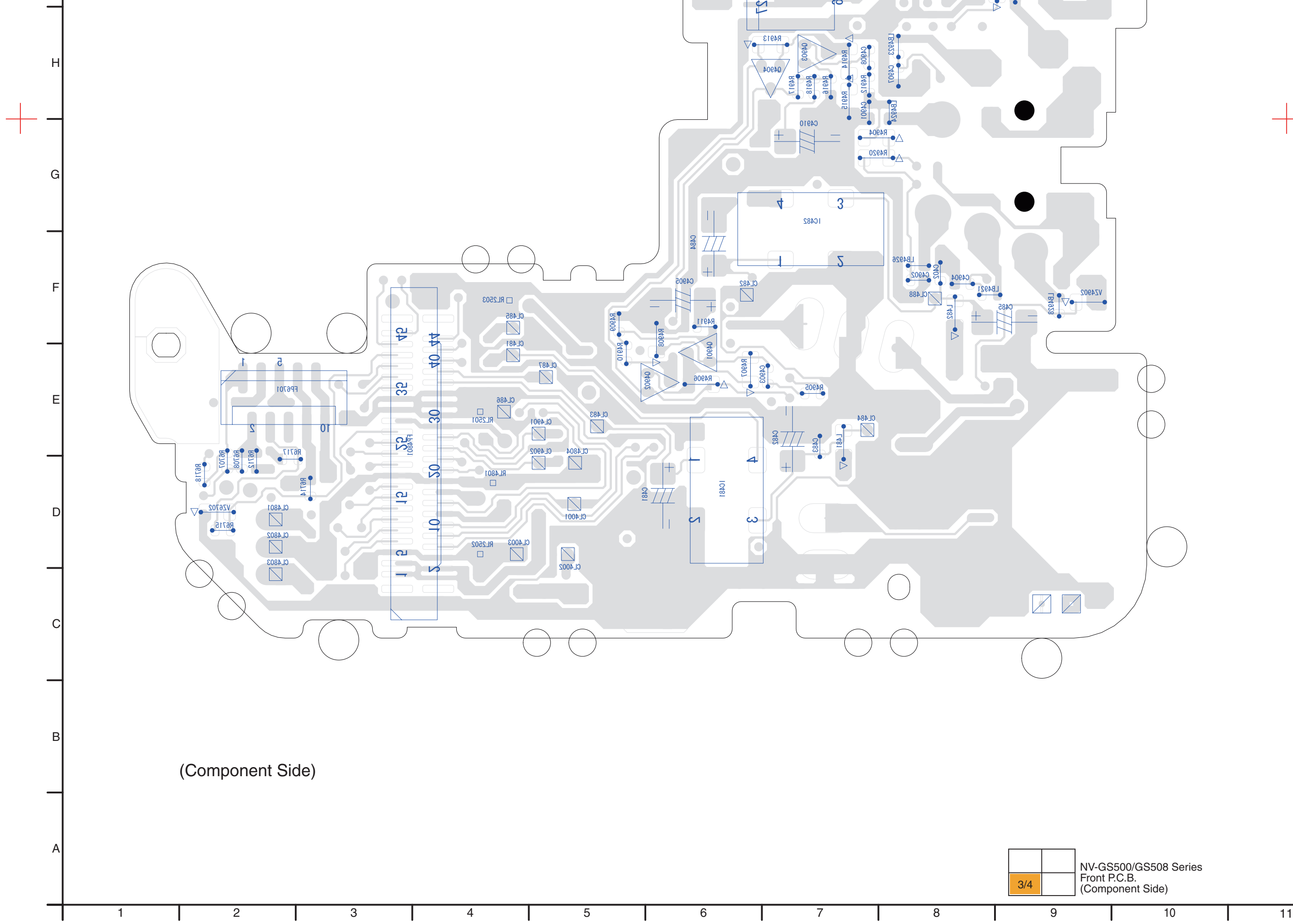

(Component Side)

		NV-GS500/GS508 Series Front P.C.B. (Component Side)
3/4		

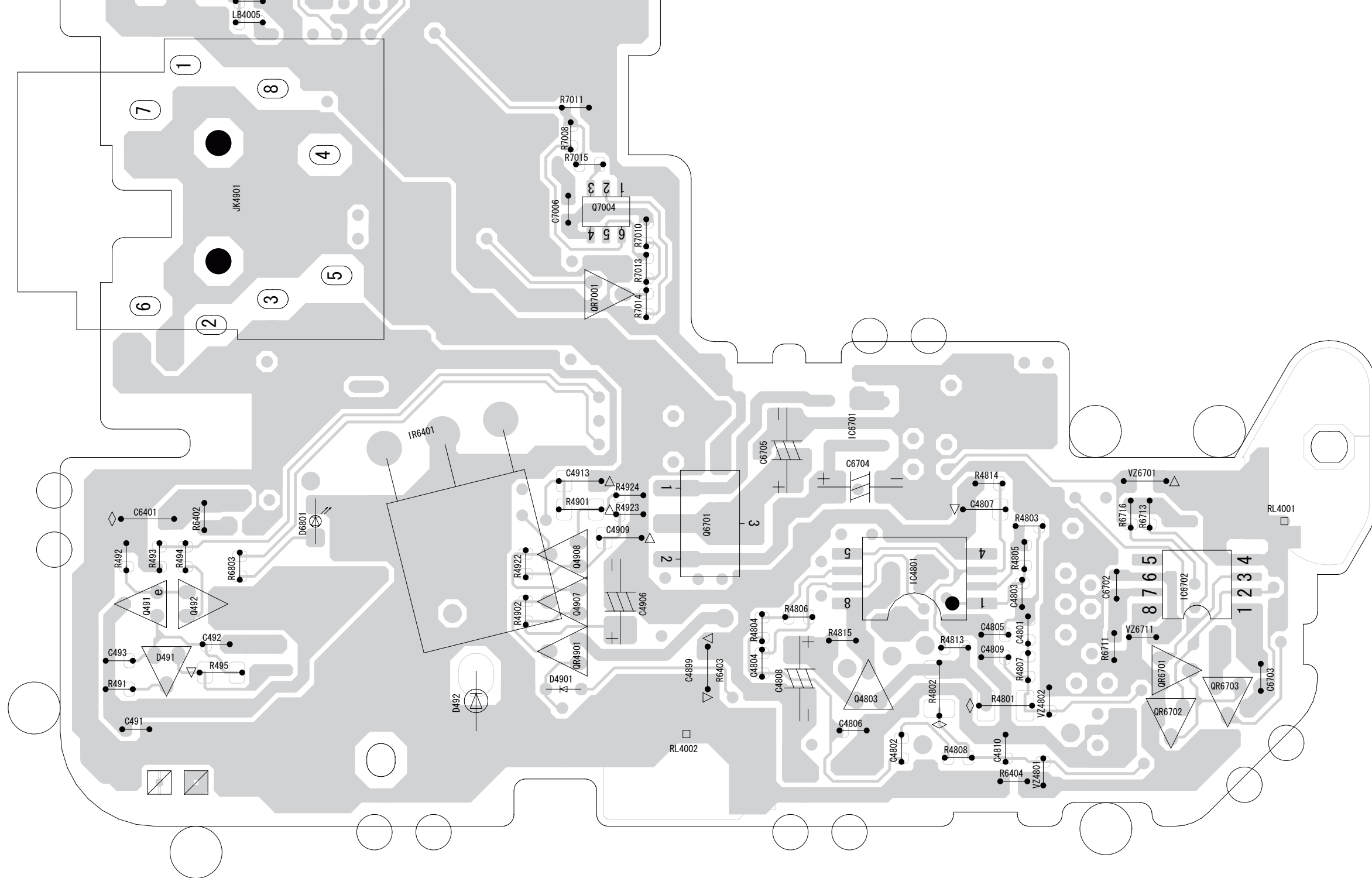

(Foil Side)

	4/4

NV-GS500/GS508 Series
Front P.C.B.
(Foil Side)

11

12

13

14

15

16

17

18

19

20

21

S5.6. Side-L P.C.B.

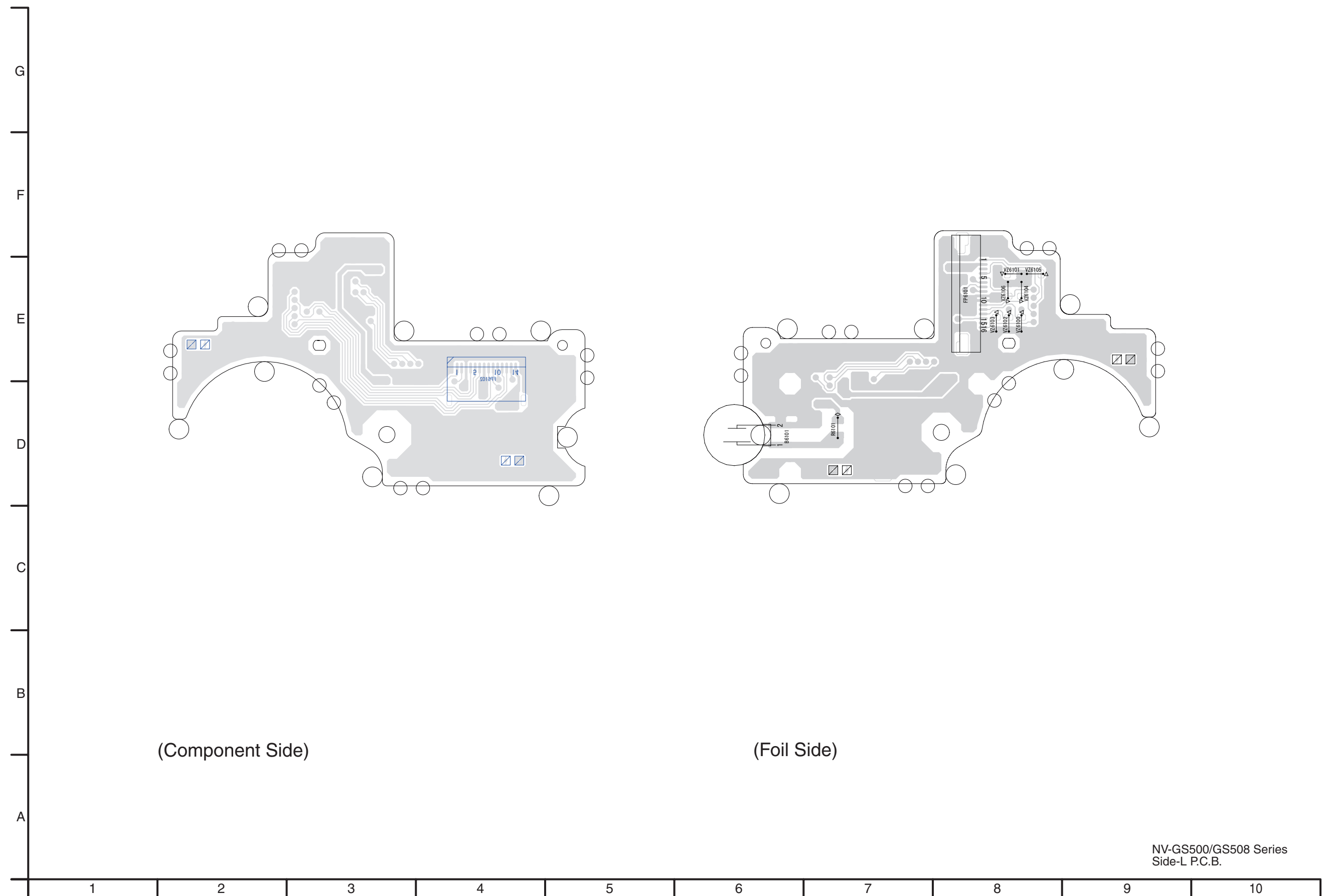

S5.7. Monitor P.C.B.

S5.7.1. Monitor P.C.B. (Component Side)

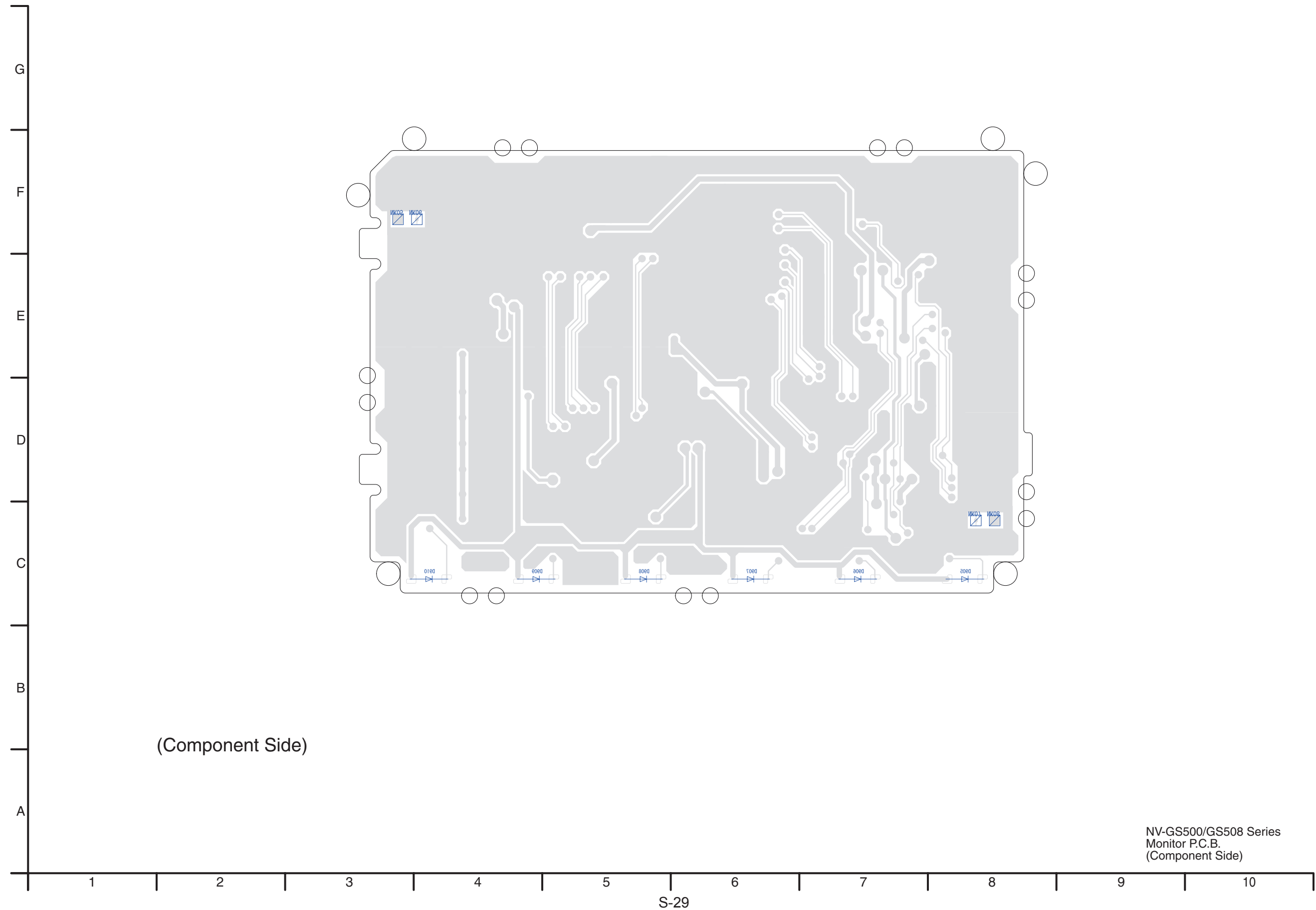

S5.7.2. Monitor P.C.B. (Foil Side)

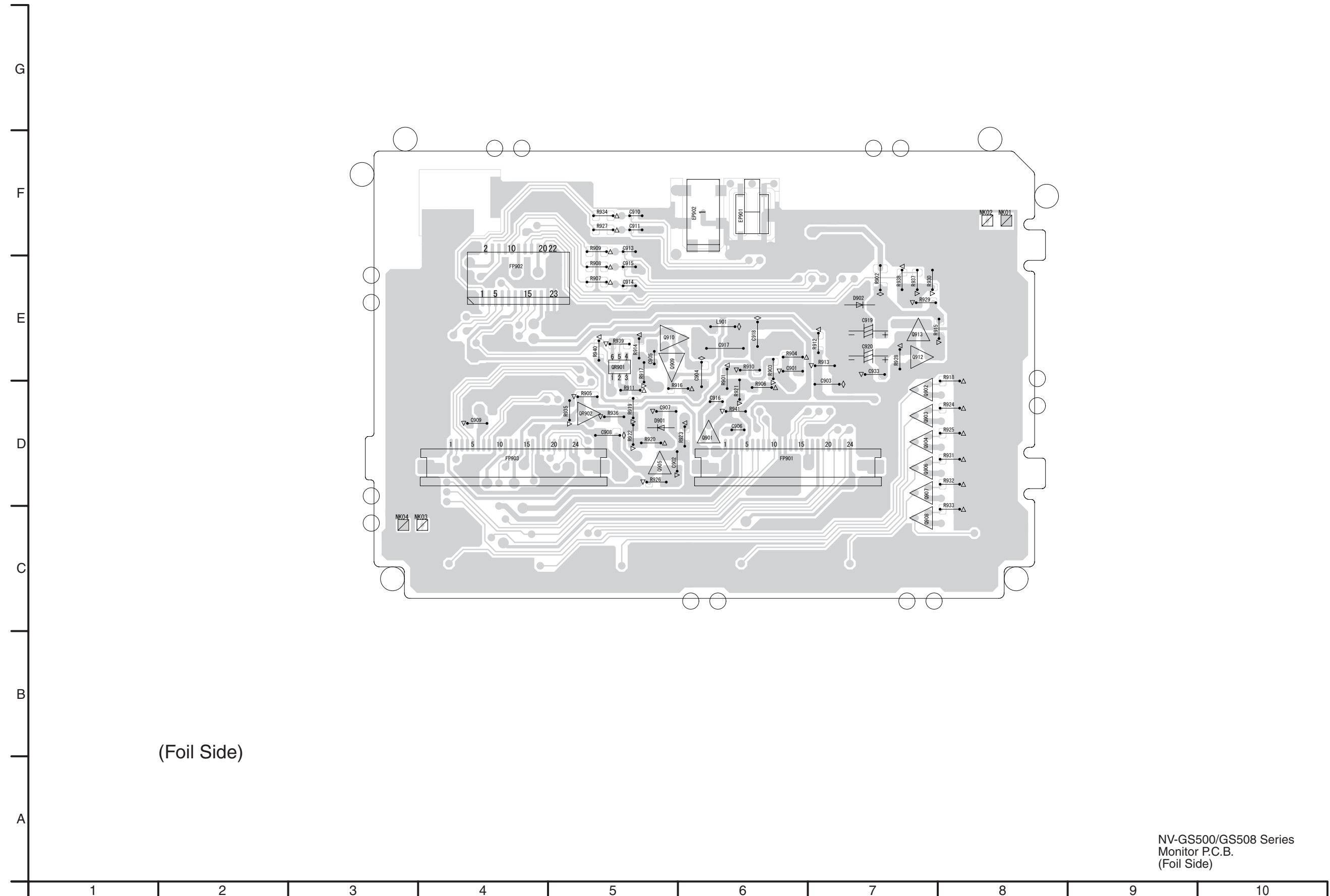

NV-GS500/GS508 Series
Monitor P.C.B.
(Foil Side)

S5.8. CCD Flex

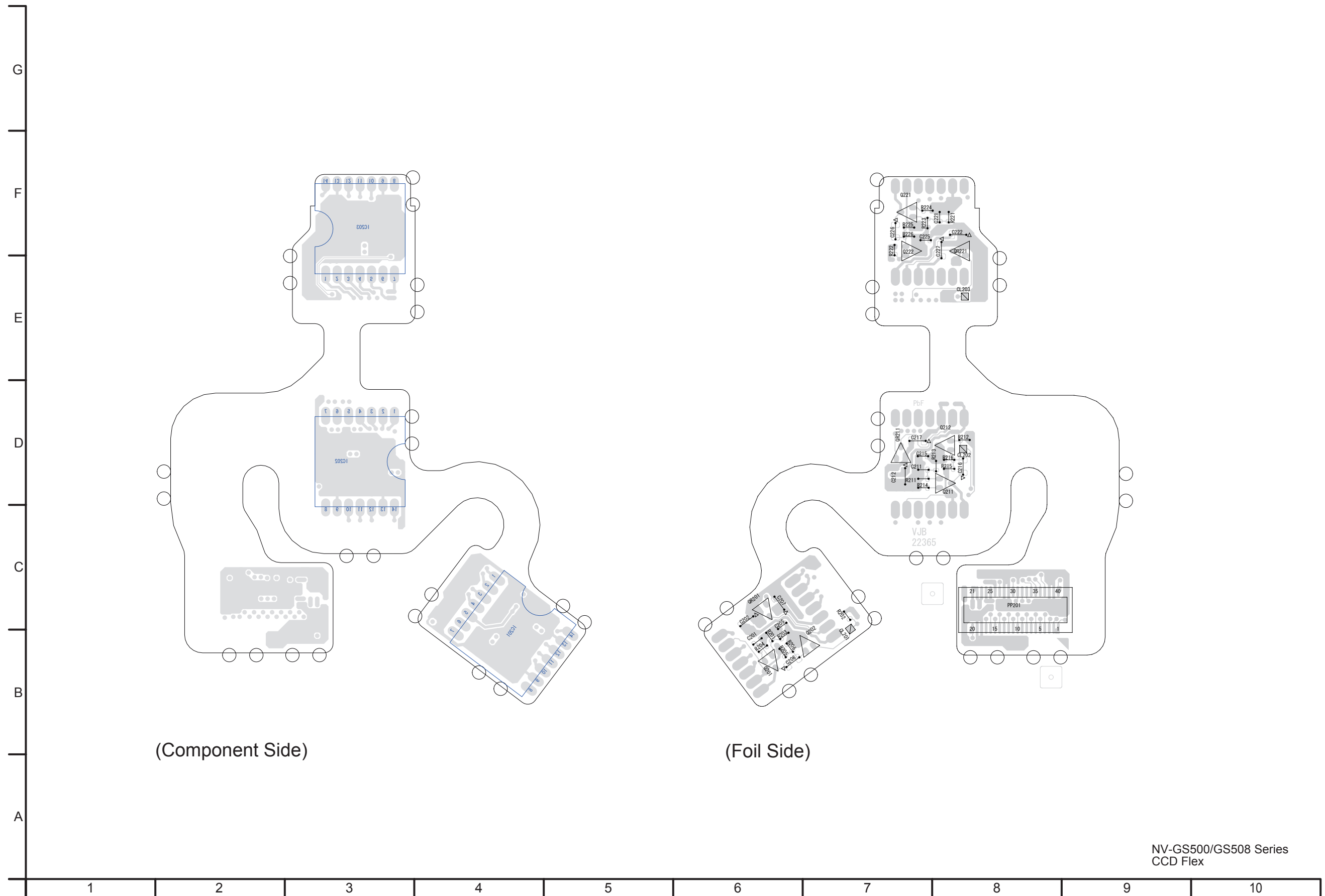

S6. Replacement Parts List

- Note:
- 1.* Be sure to make your orders of replacement parts according to this list.
 2. IMPORTANT SAFETY NOTICE
Components identified with the mark \triangle have the special characteristics for safety.
When replacing any of these components, use only the same type.
 3. Unless otherwise specified,
All resistors are in OHMS, K=1,000 OHMS. All capacitors are in MICRO-FARADS (uf), P=uuF.
 4. The marking (RTL) indicates the retention time is limited for this item. After the discontinuation of this assembly in production, it will no longer be available.

E.S.D. standards for Electrostatically Sensitive Devices, refer to “PREVENTION OF ELECTROSTATIC DISCHARGE (ESD) TO ELECTROSTATICALLY SENSITIVE (ES) DEVICES” section.

Ref.No.	Part No.	Part Name & Description	Pcs	Remarks
##		CCD FPC		
C201	ECJ0EB1A104K	C.CAPACITOR CH 10V 0.1U	1	
C202	ECJ1VB1C105K	C.CAPACITOR CH 16V 1U	1	
C205	F1G0J105A001	C.CAPACITOR CH 6.3V 1U	1	
C206	ECJ1VB1C105K	C.CAPACITOR CH 16V 1U	1	
C207	ECJ1VB1C105K	C.CAPACITOR CH 16V 1U	1	
C211	ECJ0EB1A104K	C.CAPACITOR CH 10V 0.1U	1	
C212	ECJ1VB1C105K	C.CAPACITOR CH 16V 1U	1	
C215	F1G0J105A001	C.CAPACITOR CH 6.3V 1U	1	
C216	ECJ1VB1C105K	C.CAPACITOR CH 16V 1U	1	
C217	ECJ1VB1C105K	C.CAPACITOR CH 16V 1U	1	
C221	ECJ0EB1A104K	C.CAPACITOR CH 10V 0.1U	1	
C222	ECJ1VB1C105K	C.CAPACITOR CH 16V 1U	1	
C225	F1G0J105A001	C.CAPACITOR CH 6.3V 1U	1	
C226	ECJ1VB1C105K	C.CAPACITOR CH 16V 1U	1	
C227	ECJ1VB1C105K	C.CAPACITOR CH 16V 1U	1	
PP201	VJP4009C040	CONNECTOR (MALE) 40P	1	K1KA40A00113
Q201	2SC4627JCL	TRANSISTOR	1	
Q202	2SC4627JCL	TRANSISTOR	1	
Q211	2SC4627JCL	TRANSISTOR	1	
Q212	2SC4627JCL	TRANSISTOR	1	
Q221	2SC4627JCL	TRANSISTOR	1	
Q222	2SC4627JCL	TRANSISTOR	1	
QR201	UN9211	TRANSISTOR-RESISTOR	1	UNR9211
QR211	UN9211	TRANSISTOR-RESISTOR	1	UNR9211
QR221	UN9211	TRANSISTOR-RESISTOR	1	UNR9211
R201	ERJ2GEJ123	M.RESISTOR CH 1/16W 12K	1	
R202	ERJ2GEJ391	M.RESISTOR CH 1/16W 390	1	
R203	ERJ2GEJ103	M.RESISTOR CH 1/16W 10K	1	
R204	ERJ2GEJ821	M.RESISTOR CH 1/16W 820	1	
R205	ERJ2GEJ123	M.RESISTOR CH 1/16W 12K	1	
R206	ERJ2GEJ103	M.RESISTOR CH 1/16W 10K	1	
R211	ERJ2GEJ123	M.RESISTOR CH 1/16W 12K	1	
R212	ERJ2GEJ391	M.RESISTOR CH 1/16W 390	1	
R213	ERJ2GEJ103	M.RESISTOR CH 1/16W 10K	1	
R214	ERJ2GEJ821	M.RESISTOR CH 1/16W 820	1	
R215	ERJ2GEJ123	M.RESISTOR CH 1/16W 12K	1	
R216	ERJ2GEJ103	M.RESISTOR CH 1/16W 10K	1	
R221	ERJ2GEJ123	M.RESISTOR CH 1/16W 12K	1	
R222	ERJ2GEJ391	M.RESISTOR CH 1/16W 390	1	
R223	ERJ2GEJ103	M.RESISTOR CH 1/16W 10K	1	
R224	ERJ2GEJ821	M.RESISTOR CH 1/16W 820	1	
R225	ERJ2GEJ123	M.RESISTOR CH 1/16W 12K	1	
R226	ERJ2GEJ103	M.RESISTOR CH 1/16W 10K	1	
##	VEP001L3A	SIDE-L P.C.B.		(RTL)
B6101	ML-621S/F9D	BATTERY	1	
FP6101	K1MN16BA0028	CONNECTOR 16P	1	
FP6102	K1MN14BA0197	CONNECTOR 14P	1	
R6101	ERJ6GEJY102V	M.RESISTOR CH 1/10W 1K	1	
##	VEP001L1B	SIDE-R P.C.B.		(RTL)
C601	F3F0G4760003	E.CAPACITOR CH 4V 47U	1	
C603	F1G0J105A001	C.CAPACITOR CH 6.3V 1U	1	
C604	F1G0J105A001	C.CAPACITOR CH 6.3V 1U	1	
C605	ECJ0EB1A104K	C.CAPACITOR CH 10V 0.1U	1	
C606	ECJ0EB1A104K	C.CAPACITOR CH 10V 0.1U	1	
C607	F1H0J2250003	C.CAPACITOR CH 6.3V 2.2U	1	
C608	F1H0J2250003	C.CAPACITOR CH 6.3V 2.2U	1	
C609	ECJ0EB1A104K	C.CAPACITOR CH 10V 0.1U	1	
C613	F1G0J105A001	C.CAPACITOR CH 6.3V 1U	1	

Ref.No.	Part No.	Part Name & Description	Pcs	Remarks
C614	F1H0J2250003	C.CAPACITOR CH 6.3V 2.2U	1	
C616	F1G0J105A001	C.CAPACITOR CH 6.3V 1U	1	
C624	ECJ0EB1A104K	C.CAPACITOR CH 10V 0.1U	1	
C628	F1J1A475A023	C.CAPACITOR CH 10V 4.7U	1	
C629	ECJ0EB1A104K	C.CAPACITOR CH 10V 0.1U	1	
C6301	ECJ0EB1A104K	C.CAPACITOR CH 10V 0.1U	1	
C6302	ECJ0EC1H820J	C.CAPACITOR CH 50V 82P	1	
C6303	ECJ0EC1H820J	C.CAPACITOR CH 50V 82P	1	
C6304	ECJ0EC1H820J	C.CAPACITOR CH 50V 82P	1	
C6305	ECJ0EC1H820J	C.CAPACITOR CH 50V 82P	1	
C6306	ECJ0EB1A104K	C.CAPACITOR CH 10V 0.1U	1	
C6307	ECJ0EB1A104K	C.CAPACITOR CH 10V 0.1U	1	
C6310	ECJ0EC1H050C	C.CAPACITOR CH 50V 5P	1	
C6311	F1G0J105A001	C.CAPACITOR CH 6.3V 1U	1	
C6316	F1G0J105A001	C.CAPACITOR CH 6.3V 1U	1	
C6318	F1G0J105A001	C.CAPACITOR CH 6.3V 1U	1	
C6320	F3G0J1070004	E.CAPACITOR CH 6.3V 100U	1	
C6321	F3G0J1070004	E.CAPACITOR CH 6.3V 100U	1	
C6399	ECJ0EB1E472K	C.CAPACITOR CH 25V 4700P	1	
D6393	B3AAB0000137	DIODE	1	
FL6301	F1H0J1050022	C.CAPACITOR CH 6.3V 1U	1	
FL6302	J0MAB0000212	FILTER	1	
FL6303	J0MAB0000212	FILTER	1	
FL6304	J0MAB0000212	FILTER	1	
FP601	K1MN31BA0132	CONNECTOR 31P	1	
FP602	K1MN25BA0199	CONNECTOR 25P	1	
FP6302	K1MN05BA0055	CONNECTOR 5P	1	
HS6301	K1NA09E00038	CONNECTOR 9P	1	
IC601	C1AB00002388	IC	1	
JK6301	K2HZ105D0001	JACK	1	
JK6302	K1FA104A0017	JACK	1	
LB6301	J0JAC0000014	FILTER	1	JOJAC0000016
LB6302	J0JAC0000014	FILTER	1	JOJAC0000016
LB6303	J0JAC0000014	FILTER	1	JOJAC0000016
LB6304	J0JAC0000014	FILTER	1	JOJAC0000016
LB6305	J0JAC0000014	FILTER	1	JOJAC0000016
LB6306	VLP0332A420	CHIP BEAD	1	JOJHC0000017
PS6301	K1KB60BA0065	CONNECTOR 60P	1	
Q601	B1CFHC000003	TRANSISTOR	1	
Q602	B1CFHC000003	TRANSISTOR	1	
QR601	XP4213	TRANSISTOR-RESISTOR	1	XP04213
R601	ERJ3GEY0R00	M.RESISTOR CH 1/10W 0	1	
R602	ERJ3GEY0R00	M.RESISTOR CH 1/10W 0	1	
R603	ERJ2RHD511	M.RESISTOR CH 1/16W 510	1	
R604	ERJ2RHD102	M.RESISTOR CH 1/16W 1K	1	
R605	ERJ2GEJ101	M.RESISTOR CH 1/16W 100	1	
R606	ERJ2GEJ101	M.RESISTOR CH 1/16W 100	1	
R607	ERJ2GEJ101	M.RESISTOR CH 1/16W 100	1	
R608	ERJ2RHD103	M.RESISTOR CH 1/16W 10K	1	
R609	ERJ2RHD103	M.RESISTOR CH 1/16W 10K	1	
R612	D0YAR0000007	M.RESISTOR CH 1/16W 0	1	
R614	D0YAR0000007	M.RESISTOR CH 1/16W 0	1	
R615	D0YAR0000007	M.RESISTOR CH 1/16W 0	1	
R616	D0YAR0000007	M.RESISTOR CH 1/16W 0	1	
R617	D0YAR0000007	M.RESISTOR CH 1/16W 0	1	
R619	D0YAR0000007	M.RESISTOR CH 1/16W 0	1	
R620	D0YAR0000007	M.RESISTOR CH 1/16W 0	1	
R622	ERJ2GEJ101	M.RESISTOR CH 1/16W 100	1	
R623	ERJ2GEJ101	M.RESISTOR CH 1/16W 100	1	
R625	ERJ2GEJ473Y	M.RESISTOR CH 1/16W 47K	1	
R626	ERJ2GEJ473Y	M.RESISTOR CH 1/16W 47K	1	
R630	ERJ2RHD104	M.RESISTOR CH 1/16W 100K	1	
R631	ERJ2RKD394	M.RESISTOR CH 1/16W 390K	1	
R633	D0YAR0000007	M.RESISTOR CH 1/16W 0	1	

Ref.No.	Part No.	Part Name & Description	Pcs	Remarks
R634	D0YAR0000007	M.RESISTOR CH 1/16W 0	1	
R6301	ERJ6GEYJR47	M.RESISTOR CH 1/10W 0.47	1	
R6302	ERJ2GEJ150	M.RESISTOR CH 1/16W 15	1	
R6303	ERJ2GEJ150	M.RESISTOR CH 1/16W 15	1	
R6306	ERJ2GEJ150	M.RESISTOR CH 1/16W 15	1	
R6307	ERJ2GEJ150	M.RESISTOR CH 1/16W 15	1	
R6308	ERJ2GEJ103	M.RESISTOR CH 1/16W 10K	1	
R6309	ERJ2GEJ103	M.RESISTOR CH 1/16W 10K	1	
R6310	ERJ2GEJ103	M.RESISTOR CH 1/16W 10K	1	
R6311	ERJ2GEJ103	M.RESISTOR CH 1/16W 10K	1	
R6312	ERJ6GEYJ102V	M.RESISTOR CH 1/10W 1K	1	
R6313	D0YAR0000007	M.RESISTOR CH 1/16W 0	1	
R6314	D0YAR0000007	M.RESISTOR CH 1/16W 0	1	
R6315	D0YAR0000007	M.RESISTOR CH 1/16W 0	1	
R6321	D0YAR0000007	M.RESISTOR CH 1/16W 0	1	
R6323	ERJ2GEJ101	M.RESISTOR CH 1/16W 100	1	
R6324	ERJ2GEJ101	M.RESISTOR CH 1/16W 100	1	
R6325	ERJ2GEJ101	M.RESISTOR CH 1/16W 100	1	
R6326	ERJ2RKD330	M.RESISTOR CH 1/16W 33	1	
R6327	ERJ2GEJ101	M.RESISTOR CH 1/16W 100	1	
R6330	ERJ6GEY0R00V	M.RESISTOR CH 1/10W 0	1	D0GBR00JA017
R6331	ERJ6GEY0R00V	M.RESISTOR CH 1/10W 0	1	D0GBR00JA017
R6333	ERJ3GEY0R00	M.RESISTOR CH 1/10W 0	1	
VZ6301	D4ED1270A006	SURGE ABSORBER	1	
VZ6302	D4ED1270A006	SURGE ABSORBER	1	
VZ6303	D4ED1270A006	SURGE ABSORBER	1	
VZ6305	D4ED1120A002	SURGE ABSORBER	1	
VZ6306	D4ED1120A002	SURGE ABSORBER	1	
VZ6308	D4ED1120A002	SURGE ABSORBER	1	
##	VEP001N1A	LCD DET. P.C.B.		
S6702	K0L1AA000011	SWITCH	1	
##	VEP001L5A	OPERATION (R) P.C.B.		(RTL)
R6391	D0GB473JA057	M.RESISTOR CH 1/10W 47K	1	
R6392	D0GB473JA057	M.RESISTOR CH 1/10W 47K	1	
S6391	VSS0533	SWITCH	1	K0D112A00116
S6392	K0H1BA000436	SWITCH	1	
S6394	K0H1BA000436	SWITCH	1	
VZ6391	D4ED1270A006	SURGE ABSORBER	1	
VZ6392	D4ED1270A006	SURGE ABSORBER	1	
VZ6393	D4ED1270A006	SURGE ABSORBER	1	
##	VEP08348B	MONITOR P.C.B.	1	(RTL)
C906	ECJ0EB1A104K	C.CAPACITOR CH 10V 0.1U	1	
C907	ECJ1VB1A105K	C.CAPACITOR CH 10V 1U	1	
C908	F1J1A2250007	C.CAPACITOR CH 10V 2.2U	1	
C909	ECJ1VB1A105K	C.CAPACITOR CH 10V 1U	1	
C913	ECJ0EC1H390J	C.CAPACITOR CH 50V 39P	1	
C914	ECJ0EC1H390J	C.CAPACITOR CH 50V 39P	1	
C915	ECJ0EC1H390J	C.CAPACITOR CH 50V 39P	1	
C918	F1J1A475A023	C.CAPACITOR CH 10V 4.7U	1	
C933	ECJ1VBOJ105K	C.CAPACITOR CH 6.3V 1U	1	
D901	MAZ80560ML	ZENNER DIODE	1	
D902	B0BC6R100025	DIODE	1	
D905	B3AFB0000117	DIODE	1	
D906	B3AFB0000117	DIODE	1	
D907	B3AFB0000117	DIODE	1	
D908	B3AFB0000117	DIODE	1	
D909	B3AFB0000117	DIODE	1	
D910	B3AFB0000117	DIODE	1	

Ref.No.	Part No.	Part Name & Description	Pcs	Remarks
FP902	K1MN23BA0132	CONNECTOR 23P	1	
FP903	K1MN24BA0055	CONNECTOR 24P	1	
L901	G1C101KA0055	CHIP INDUCTOR 100UH	1	
Q901	2SA2174J0L	TRANSISTOR	1	
Q902	2SC6054J0L	TRANSISTOR	1	
Q903	2SC6054J0L	TRANSISTOR	1	
Q904	2SC6054J0L	TRANSISTOR	1	
Q905	2SA2174J0L	TRANSISTOR	1	
Q906	2SC6054J0L	TRANSISTOR	1	
Q907	2SC6054J0L	TRANSISTOR	1	
Q908	2SC6054J0L	TRANSISTOR	1	
Q913	2SA2174J0L	TRANSISTOR	1	
R901	ERJ3GEY0R00	M.RESISTOR CH 1/10W 0	1	
R902	ERJ6GEY0R00V	M.RESISTOR CH 1/10W 0	1	D0GBR00JA017
R906	ERJ3RBD563	M.RESISTOR CH 1/16W 56K	1	ERJ3RBD563V
R907	ERJ3RBD271	M.RESISTOR CH 1/16W 270	1	
R908	ERJ3RBD271	M.RESISTOR CH 1/16W 270	1	
R909	ERJ3RBD271	M.RESISTOR CH 1/16W 270	1	
R910	ERJ3RBD562	M.RESISTOR CH 1/16W 5.6K	1	
R915	D0GB102JA057	M.RESISTOR CH 1/10W 1K	1	
R916	ERJ3GEY0R00	M.RESISTOR CH 1/10W 0	1	
R918	ERJ3RED270	M.RESISTOR CH 1/16W 27	1	
R924	ERJ3RED270	M.RESISTOR CH 1/16W 27	1	
R925	ERJ3RED270	M.RESISTOR CH 1/16W 27	1	
R926	ERJ3GEYJ104	M.RESISTOR CH 1/10W 100K	1	
R927	ERJ3GEY0R00	M.RESISTOR CH 1/10W 0	1	
R930	ERJ3RBD103	M.RESISTOR CH 1/16W 10K	1	
R931	ERJ3RED270	M.RESISTOR CH 1/16W 27	1	
R932	ERJ3RED270	M.RESISTOR CH 1/16W 27	1	
R933	ERJ3RED270	M.RESISTOR CH 1/16W 27	1	
R934	ERJ3GEY0R00	M.RESISTOR CH 1/10W 0	1	
R937	ERJ3RBD473	M.RESISTOR CH 1/16W 47K	1	
R940	D0GB103JA057	M.RESISTOR CH 1/10W 10K	1	
R941	D0GB473JA057	M.RESISTOR CH 1/10W 47K	1	
##	VEP001N0A	SIDE-R FPC		
PS6302	K1KA60BA0297	CONNECTOR 60P	1	
PS6303	K1KA60A00177	CONNECTOR 60P	1	
##	VEP29171A	EVF B/L P.C.B.		(RTL)
C853	ECJ1VB1A105K	C.CAPACITOR CH 10V 1U	1	
C854	ECJ0EB1A104K	C.CAPACITOR CH 10V 0.1U	1	
C855	ECJ0EB1A104K	C.CAPACITOR CH 10V 0.1U	1	
D855	B3AFB0000129	DIODE	1	
D856	B0BC6R100025	DIODE	1	
D857	MA3S13300L	DIODE	1	
D858	MAZ80560ML	ZENNER DIODE	1	
FP853	K1MN18BA0050	CONNECTOR 18P	1	
FP854	K1MN20BA0050	CONNECTOR 20P	1	
Q852	2SC6054J0L	TRANSISTOR	1	
R852	ERJ3GEYJ122	M.RESISTOR CH 1/10W 1.2K	1	
R853	D0GB152JA057	M.RESISTOR CH 1/10W 1.5K	1	
R855	D0GB105JA057	M.RESISTOR CH 1/10W 1M	1	
R856	ERJ3GEYJ472	M.RESISTOR CH 1/10W 4.7K	1	
R857	ERJ3RBD101	M.RESISTOR CH 1/16W 100	1	ERJ3RBD101V
##	VEP29172A	EVF FPC UNIT		
S801	ESE18R62D	SWITCH	1	

Ref.No.	Part No.	Part Name & Description	Pcs	Remarks
##	VEP04899B	FRONT P.C.B.		(RTL)
C481	F3F0J226A057	E.CAPACITOR CH 6.3V 22U	1	
C482	F3F0J226A057	E.CAPACITOR CH 6.3V 22U	1	
C484	F3F0J226A057	E.CAPACITOR CH 6.3V 22U	1	
C485	F3F0J226A057	E.CAPACITOR CH 6.3V 22U	1	
C491	ECJ0EB1A104K	C.CAPACITOR CH 10V 0.1U	1	
C492	F1G0J224A004	C.CAPACITOR CH 6.3V 0.22U	1	
C493	F1G0J224A004	C.CAPACITOR CH 6.3V 0.22U	1	
C4003	ECJ0EB1E472K	C.CAPACITOR CH 25V 4700P	1	
C4004	ECJ0EB1E472K	C.CAPACITOR CH 25V 4700P	1	
C4007	F1G0J105A001	C.CAPACITOR CH 6.3V 1U	1	
C4801	ECJ0EB1A473K	C.CAPACITOR CH 10V 0.047U	1	
C4802	ECJ0EB1A473K	C.CAPACITOR CH 10V 0.047U	1	
C4803	ECJ0EB1E561K	C.CAPACITOR CH 25V 560P	1	
C4804	ECJ0EB1E561K	C.CAPACITOR CH 25V 560P	1	
C4807	F1H0J475A009	C.CAPACITOR CH 6.3V 4.7U	1	
C4808	F3F0J226A057	E.CAPACITOR CH 6.3V 22U	1	
C4809	ECJ0EC1H101J	C.CAPACITOR CH 50V 100P	1	
C4810	ECJ0EC1H101J	C.CAPACITOR CH 50V 100P	1	
C4899	ECJ1VB1C105K	C.CAPACITOR CH 16V 1U	1	
C4901	ECJ0EB1E472K	C.CAPACITOR CH 25V 4700P	1	
C4902	ECJ0EB1E472K	C.CAPACITOR CH 25V 4700P	1	
C4903	F1G0J105A001	C.CAPACITOR CH 6.3V 1U	1	
C4904	F1G0J105A001	C.CAPACITOR CH 6.3V 1U	1	
C4905	F3F0J226A057	E.CAPACITOR CH 6.3V 22U	1	
C4906	F3F0J226A057	E.CAPACITOR CH 6.3V 22U	1	
C4908	F1G0J105A001	C.CAPACITOR CH 6.3V 1U	1	
C4909	ECJ1VB1C105K	C.CAPACITOR CH 16V 1U	1	
C4910	F3F0J226A057	E.CAPACITOR CH 6.3V 22U	1	
C4913	F1H0J475A009	C.CAPACITOR CH 6.3V 4.7U	1	
C6401	F1J0J106A025	C.CAPACITOR CH 6.3V 10U	1	
C7001	ECJ1VB1C105K	C.CAPACITOR CH 16V 1U	1	
C7002	ECJ1XB1H471K	C.CAPACITOR CH 50V 470P	1	
C7003	ECJ0EB1A104K	C.CAPACITOR CH 10V 0.1U	1	
C7004	F2AZZ6500004	CAPACITOR	1	
C7006	ECJ0EB1A104K	C.CAPACITOR CH 10V 0.1U	1	
C7007	ECJ0EB1E472K	C.CAPACITOR CH 25V 4700P	1	
D491	MA3S132D0L	DIODE	1	
D492	B3GA00000047	DIODE	1	
D4901	B0JCDD000002	DIODE	1	
D6801	B3AAB0000137	DIODE	1	
D7001	MA2S11100L	DIODE	1	
D7003	B0ECKT000002	DIODE	1	
D7004	B0BC30000001	DIODE	1	
D7006	B0JCDD000002	DIODE	1	
FP4801	K1MN45A00002	CONNECTOR 45P	1	
FP6701	K1MN10A000074	CONNECTOR 10P	1	
FP7002	K1MN27B00036	CONNECTOR 27P	1	
IC481	L2ES00000015	IC	1	
IC482	L2ES00000014	IC	1	
IC4801	NJM2115V	IC	1	COABBB000104
IC7003	B1JBLP000011	IC	1	
IR6401	B3RAB0000030	IR RECEIVER	1	
JK4001	K2HZ110E0002	JACK	1	
JK4901	K2HC107B0003	JACK	1	
L481	G1C100MA0211	COIL 10UH	1	
L482	G1C100MA0211	COIL 10UH	1	
L7001	G1C560MA0024	CHIP INDUCTOR 56UH	1	
LB4001	J0JBC0000054	FILTER	1	J0JBC0000059
LB4003	J0JAC0000014	FILTER	1	J0JAC0000016
LB4005	J0JAC0000014	FILTER	1	J0JAC0000016
LB4006	J0JAC0000014	FILTER	1	J0JAC0000016
LB4007	J0JBC0000054	FILTER	1	J0JBC0000059
LB4008	J0JBC0000054	FILTER	1	J0JBC0000059
LB4921	J0JBC0000107	FILTER	1	

Ref.No.	Part No.	Part Name & Description	Pcs	Remarks
LB4922	J0JBC0000107	FILTER	1	
LB4923	J0JBC0000107	FILTER	1	
LB4924	J0JBC0000107	FILTER	1	
LB4926	J0JBC0000107	FILTER	1	
LB4928	J0JBC0000107	FILTER	1	
Q491	B1ABCFO00100	TRANSISTOR	1	
Q492	2SC6054J0L	TRANSISTOR	1	
Q4803	2SC6054J0L	TRANSISTOR	1	
Q4901	2SC6054J0L	TRANSISTOR	1	
Q4902	2SA2174J0L	TRANSISTOR	1	
Q4903	2SC6054J0L	TRANSISTOR	1	
Q4904	2SA2174J0L	TRANSISTOR	1	
Q4907	2SC6054J0L	TRANSISTOR	1	
Q4908	2SC6054J0L	TRANSISTOR	1	
Q7001	2SC6054J0L	TRANSISTOR	1	
Q7002	B1ABPF000009	TRANSISTOR	1	
Q7003	2SC6054J0L	TRANSISTOR	1	
Q7004	XP0460100L	TRANSISTOR	1	
QR4901	UNR91A3J0L	TRANSISTOR	1	
QR7001	UNR92A4J0L	TRANSISTOR	1	
QR7008	UNR92A4J0L	TRANSISTOR	1	
R491	ERJ2GEJ225	M.RESISTOR CH 1/16W 2.2M	1	ERJ2RMJ225X
R492	ERJ2GEJ334	M.RESISTOR CH 1/16W 330K	1	
R493	ERJ2GEJ472	M.RESISTOR CH 1/16W 4.7K	1	
R494	ERJ2GEJ182	M.RESISTOR CH 1/16W 1.8K	1	
R495	ERJ3GEYJ106	M.RESISTOR CH 1/10W 10M	1	
R4001	D0YAR0000007	M.RESISTOR CH 1/16W 0	1	
R4801	ERJ6GEYG392	M.RESISTOR CH 1/10W 3.9K	1	
R4802	ERJ6GEYG392	M.RESISTOR CH 1/10W 3.9K	1	
R4803	D0YAR0000007	M.RESISTOR CH 1/16W 0	1	
R4804	D0YAR0000007	M.RESISTOR CH 1/16W 0	1	
R4805	ERJ2GEJ683	M.RESISTOR CH 1/16W 68K	1	
R4806	ERJ2GEJ683	M.RESISTOR CH 1/16W 68K	1	
R4807	ERJ2RHD682X	M.RESISTOR CH 1/16W 6.8K	1	
R4808	ERJ2RHD682X	M.RESISTOR CH 1/16W 6.8K	1	
R4813	ERJ2GEJ223	M.RESISTOR CH 1/16W 22K	1	
R4814	ERJ2GEJ333	M.RESISTOR CH 1/16W 33K	1	
R4815	ERJ2GEJ472	M.RESISTOR CH 1/16W 4.7K	1	
R4901	ERJ3RBD331	M.RESISTOR CH 1/16W 330	1	
R4902	ERJ2GEJ472	M.RESISTOR CH 1/16W 4.7K	1	
R4904	ERJ3RBD562	M.RESISTOR CH 1/16W 5.6K	1	
R4905	ERJ2GEJ471	M.RESISTOR CH 1/16W 470	1	
R4906	ERJ3RBD103	M.RESISTOR CH 1/16W 10K	1	
R4907	VRE0071E154	M.RESISTOR 150K	1	DOHB154ZA004
R4908	ERJ3RBD563	M.RESISTOR CH 1/16W 56K	1	ERJ3RBD563V
R4909	ERJ2GEJ102X	M.RESISTOR CH 1/16W 1K	1	ERJ2RMJ102X
R4910	ERJ2GEJ562	M.RESISTOR CH 1/16W 5.6K	1	
R4911	ERJ2GEJ151	M.RESISTOR CH 1/16W 150	1	
R4912	ERJ2GEJ471	M.RESISTOR CH 1/16W 470	1	
R4913	ERJ3RBD103	M.RESISTOR CH 1/16W 10K	1	
R4914	VRE0071E154	M.RESISTOR 150K	1	DOHB154ZA004
R4915	ERJ3RBD563	M.RESISTOR CH 1/16W 56K	1	ERJ3RBD563V
R4916	ERJ2GEJ102X	M.RESISTOR CH 1/16W 1K	1	ERJ2RMJ102X
R4917	ERJ2GEJ562	M.RESISTOR CH 1/16W 5.6K	1	
R4918	ERJ2GEJ151	M.RESISTOR CH 1/16W 150	1	
R4920	ERJ3RBD562	M.RESISTOR CH 1/16W 5.6K	1	
R4922	ERJ2GEJ223	M.RESISTOR CH 1/16W 22K	1	
R4923	ERJ2GEJ683	M.RESISTOR CH 1/16W 68K	1	
R4924	ERJ2GEJ473Y	M.RESISTOR CH 1/16W 47K	1	
R6402	ERJ2RDK330	M.RESISTOR CH 1/16W 33	1	
R6711	D0YAR0000007	M.RESISTOR CH 1/16W 0	1	
R6712	D0YAR0000007	M.RESISTOR CH 1/16W 0	1	
R6713	D0YAR0000007	M.RESISTOR CH 1/16W 0	1	
R6714	D0YAR0000007	M.RESISTOR CH 1/16W 0	1	
R6717	D0YAR0000007	M.RESISTOR CH 1/16W 0	1	
R6718	D0YAR0000007	M.RESISTOR CH 1/16W 0	1	
R6803	ERJ2GEJ331	M.RESISTOR CH 1/16W 330	1	
R7001	ERJ2GEJ103	M.RESISTOR CH 1/16W 10K	1	
R7002	ERJ2GEJ103	M.RESISTOR CH 1/16W 10K	1	
R7003	ERJ2GEJ101	M.RESISTOR CH 1/16W 100	1	
R7005	ERJ2GEJ334	M.RESISTOR CH 1/16W 330K	1	
R7006	ERJ2GEJ564	M.RESISTOR CH 1/16W 560K	1	

Ref.No.	Part No.	Part Name & Description	Pcs	Remarks
1	VYK1U37	SIDE CASE (R) 3 UNIT	1	
2	VGL1163	SD PANEL LIGHT	1	
3	VGQ8659	KNOB HOLDER	1	
4	VGU9890	MODE CHANGE KNOB	1	
5	VMB4019	SD DOOR SPRING	1	
6	VKF4054	SD DOOR	1	
7	VYQ3681	HOOD UNIT	1	
8	VYQ3682	MF UNIT	1	
8-1	VEP20B51A	MF FPC	1	
9	VEP001L1B	SIDE-R P.C.B.	1	(RTL)
10	VEP001N1A	LCD DET. P.C.B.	1	
11	VGQ6816	SHEET	1	
12	VEP001L5A	OPERATION (R) P.C.B.	1	(RTL)
13	VEP001N0A	SIDE-R FPC	1	
14	VGQ8661	TRIPOD SHEET	1	
15	VKM6856	FLASH TOP CASE	1	
16	VMP8502	HINGE HOLD PLATE	1	
17	VSC5787	SR RADIATION PLATE B	1	
18	VGQ8723	LCD HOLDER	1	
19	L5BDDXH00016	LCD PANEL	1	
20	VGL1144	EVF DEFUSION SHEET	1	
21	VGL1175	BL POLARIZING PLATE	1	
22	VGQ8346	LCD PIECE	1	
23	VGQ7102	BL PIECE	1	
24	VGQ8335	POLARIZING SHEET HOLDER	1	
25	VGL1174	LENS POLARIZING SHEET	1	
26	VEP29171A	EVF B/L P.C.B.	1	(RTL)
27	VYK1U15	EVF (1)	1	
28	VKM6861	FLASH BOTTOM CASE	1	
29	VMP8532	FLASH FRAME	1	
30	VKM6842	EVF CASE (B)	1	
31	VKM6841	EVF CASE (T)	1	
32	VGQ8895	SHEET	1	
33	VGQ8886	MONITOR FPC BARRIER	1	
34	VMG1107	DUMPER RUBBER	1	
35	VEP29172A	EVF FPC UNIT	1	
36	VMS7665	SD DOOR SHAFT	1	
37	VXA8211	EVF SLIDE UNIT	1	
38	VGQ8694	HEAT RADIATION DUCT	1	
39	K1FB108H0019	RECTANGULAR CONNECTOR	1	
40	VKM6843	FRONT CASE	1	
41	VKW3298	SENSOR WINDOW	1	
42	VGL1173	TALLY PANEL LIGHT	1	
43	VKF4061	JACK COVER	1	
44	VSC5778	SR HEAT RADIATION PLATE	1	
45	VGK3187	LENS ORNAMENT	1	
46	VGQ8809	SHEET	1	
47	VGQ8809	SHEET	1	
48	VWJ1807	FRONT FPC	1	
49	VEP04899B	FRONT P.C.B.	1	(RTL)
49-1	VGQ8878	CONDENSER HOLDER -1	1	
49-2	VMP8493	MIC ANGLE A	1	
49-3	VMP8547	MIC ANGLE B	1	
49-4	VEP04900A	ECM P.C.B.	1	(RTL)
49-5	VGQ8880	FR-PCB BARRIER	1	
50	VGQ8816	MIC SHEET	1	
51	VGQ8701	MIC PIECE	1	
52	EFN-MVV36ZC	FLASH UNIT	1	
53	VGQ8907	SHEET	1	
B1	VHD1821	SCREW	1	
B2	VHD1384	SCREW	1	
B3	VHD1384	SCREW	1	
B4	XQN16+B3FN	SCREW	1	
B5	XQN16+B3FN	SCREW	1	
B6	XQN16+B3FN	SCREW	1	
B7	XQN16+BJ4FN	SCREW	1	
B8	XQN16+B5FN	SCREW	1	
B9	VHD1411	SCREW	1	
B10	VHD1411	SCREW	1	
B12	XQN16+BJ6FN	SCREW	1	
B13	XQN16+BJ6FN	SCREW	1	
B14	XQN16+BJ6FN	SCREW	1	
B15	XQN16+BJ8FN	SCREW	1	

Ref.No.	Part No.	Part Name & Description	Pcs	Remarks
B16	XQN16+BJ8FN	SCREW	1	
B17	XQS2+A25FN	SCREW	1	
B18	XQS2+A25FN	SCREW	1	
B19	XQN16+BJ6FN	SCREW	1	
B20	VHD1384	SCREW	1	
B21	XQN16+BJ6FN	SCREW	1	
B22	XQN16+BJ4FN	SCREW	1	
B23	XQN16+BJ4FN	SCREW	1	
B24	XQN16+BJ6FN	SCREW	1	
B25	XQN16+B4FN	SCREW	1	
B26	XQN16+B3FN	SCREW	1	
B27	XQN16+B3FN	SCREW	1	
B28	XQN16+B3FN	SCREW	1	
B29	XQN16+BJ6FN	SCREW	1	
B30	VHD1526-1	SCREW	1	
B31	VHD1526-1	SCREW	1	
B33	XQN16+B5FN	SCREW	1	
B34	XQN16+BJ6FN	SCREW	1	
B35	XQN16+BJ6FN	SCREW	1	
B36	XQN16+BJ3FN	SCREW	1	
B37	XQN16+B3FN	SCREW	1	

Ref.No.	Part No.	Part Name & Description	Pcs	Remarks	Ref.No.	Part No.	Part Name & Description	Pcs	Remarks
101	N9Z20000322	GRIP OPERATING UNIT	1		201	VKM6897	LCD CASE (T)	1	(EXCEPT GK-S)
102	VML3927	CASSETTE LOCK LEVER	1		201	VKM6898	LCD CASE (T)	1	GK
103	VMB3856	CASSETTE LOCK SPRING	1		202	VKM6840	LCD CASE (B)	1	
104	VGK3197	CASSETTE COVER ORNAMENT	1		203	VSC5790	LCD SHIELD CASE	1	
105	VEP001L3A	SIDE-L P.C.B.	1	(RTL)	204	L5BDDYH00022	LCD PANEL	1	
106	VGQ5908	SPEAKER SHEET	1		205	VGQ8662	HOLDER	1	
107	VGU9905	BATTERY LOCK KNOB	1		206	VGL1165	PRISM SHEET A	1	
108	VGQ8735	BATTERY LOCK PIECE	1		207	VGL1166	PRISM SHEET B	1	
109	VMB3602	BATTERY LOCK SPRING	1		208	VGL1164	DIFFUSION SHEET	1	
110	VMP8486	HEAT SINK	1		209	VKW3296	LIGHTING PLATE	1	
111	VKM6836	REAR CASE	1		210	VGL1167	REFLECTION SHEET	1	
112	VYQ0938	GRIP BELT (1)	1		211	VEP08348B	MONITOR P.C.B.	1	(RTL)
114	VEK0J51	BATTERY FPC UNIT	1		212	VXD0470	LCD HINGE (1) UNIT	1	
115	VKM6830	SIDE CASE (L)	1		213	VGQ8695	HINGE COVER (T)	1	
116	VKF4050	MECHANISM ADJ. COVER	1		214	VGQ8762	HINGE COVER (B)	1	
117	VMP8487	BELT PLATE	1		215	VSC5774	LCD GROUND PLATE	1	
118	VKM6837	TOP CASE	1		216	VGQ8724	LCD CASE (MID)	1	
119	VMP8501	LENS FRAME	1						
120	VGQ8879	FRONT BARRIER	1		B201	VHD1688	SCREW	1	
121	VSC5785	CCD RADIATION PLATE	1		B202	VHD1688	SCREW	1	
122	VGQ8455	CAPSTAN FPC SHEET	1		B203	VHD1831	SCREW	1	
123	VEP03G87K	MAIN P.C.B.	1	(RTL) EG,EB,EP,E	B204	VHD1831	SCREW	1	
123	VEP03G87L	MAIN P.C.B.	1	(RTL) EE,GC,GN,SG					
123	VEP03G87U	MAIN P.C.B.	1	(RTL) GCT					
123	VEP03G87R	MAIN P.C.B.	1	(RTL) PL					
123	VEP03G87Q	MAIN P.C.B.	1	(RTL) GT					
123	VEP03G87M	MAIN P.C.B.	1	(RTL) GK					
123-1	VGQ8887	DPR SHEET	1						
124	VEP23646B	SUB P.C.B.	1	(RTL) EG,EB,EP,EE,E,GC, GN,SG,GCT,GK					
124	VEP23646C	SUB P.C.B.	1	(RTL) PL,GT					
125	VYK1S65	MECHA FRAME UNIT	1						
126	VGQ8897	LENS CUSSION	1						
127	VMG1107	DUMPER RUBBER	1						
128	VMG1107	DUMPER RUBBER	1						
B101	XQN16+BJ4FN	SCREW	1						
B102	XQN16+B2FN	SCREW	1						
B103	XQN16+B2FN	SCREW	1						
B104	XQN16+BJ4FN	SCREW	1						
B105	XQN16+BJ4FN	SCREW	1						
B106	XQN16+BJ4FN	SCREW	1						
B107	XQN16+BJ4FN	SCREW	1						
B108	VHD1658	SCREW	1						
B109	XQN16+B3FN	SCREW	1						
B110	XQN16+B3FN	SCREW	1						
B111	XQN16+B35FN	SCREW	1						
B112	XQN16+BJ6FN	SCREW	1						
B113	XQN16+BJ4FN	SCREW	1						
B115	VHD1133	SCREW	1						
B116	VHD1133	SCREW	1						
B117	VHD1133	SCREW	1						
B118	XQN16+B3FN	SCREW	1						
B119	XQN16+B3FN	SCREW	1						
B120	XQN16+B6FN	SCREW	1						
B123	VHD1353	SCREW	1						
B124	XQN16+BJ4FN	SCREW	1						
B125	XQN16+BJ4FN	SCREW	1						
B127	VHD1848	SCREW	1						

Ref.No.	Part No.	Part Name & Description	Pcs	Remarks
301	VXQ1403	PRISM (1)	1	
302	VXW0774	LENS UNIT	1	
302-1	VXQ1231	MASTER FLANGE	1	
302-2	VMS6838	FOCUS GUIDE POLE	1	
302-3	VMS6838	FOCUS GUIDE POLE	1	
302-4	VXP2381	4TH MOVING FRAME UNIT	1	
302-5	VMS7508	ZOOM GUIDE POLE	1	
302-6	VMS7508	ZOOM GUIDE POLE	1	
302-7	VMA0S74	SIDE YORK	1	
302-8	VMA0S74	SIDE YORK	1	
302-9	VXQ1233	OIS	1	
302-10	L9ZZ00000233	IRIS	1	
302-11	VXQ1404	MAIN BODY	1	
302-12	L6HA66NC0008	STEPPING MOTOR	1	
302-13	VEK0J50	LENS FPC	1	
302-14	VXP2624	2ND MOVING FRAME UNIT	1	
B301	XQN16+CJ5FJ	SCREW	1	
B302	XQN16+CJ5FJ	SCREW	1	
B304	VHD1508-1	SCREW	1	
B305	XQN16+CJ7FJ	SCREW	1	
B306	XQN16+CJ7FJ	SCREW	1	
B307	XQN16+CJ7FJ	SCREW	1	
B308	XQN16+CJ7FJ	SCREW	1	
B309	XQN16+CJ5FJ	SCREW	1	
B310	XQN16+CJ5FJ	SCREW	1	
B311	XQN16+CJ5FJ	SCREW	1	
B312	XQN16+CJ5FJ	SCREW	1	

Ref.No.	Part No.	Part Name & Description	Pcs	Remarks
501	VXA8276	MECHANISM CHASSIS	1	
501-1	VXA8198	CASSETTE UP UNIT	1	
501-1-1	VMB3766	CASSETTE UP SPRING	1	
501-2	VXR0403	T REEL MOTOR	1	
502	VEG1663	CYLINDER UNIT	1	
B501	VHD1632	SCREW	1	
B502	VHD1757	SCREW	1	
B503	VHD1757	SCREW	1	
B504	VHD1757	SCREW	1	
B505	VHD1754	SCREW	1	
B506	VHD1754	SCREW	1	
B507	VHD1753	SCREW	1	

Ref.No.	Part No.	Part Name & Description	Pcs	Remarks	Ref.No.	Part No.	Part Name & Description	Pcs	Remarks
401	VPG1F06	PACKING CASE	1	(EXCEPT GK)					
401	VPG1F07	PACKING CASE	1	GK					
402	VPN6367	CUSHION	1						
403	VPK2942	ACCESSORIES BOX	1						
405	K2GJ2DZ00018	DC CABLE	1						
406	K2KZ9CB00001	AV CABLE	1						
△ 407	K2CQ2CA00006	AC CORD	1	EG,EP,EE,E,GC,SG,GCT,PL					
△ 407	K2CT3CA00004	AC CORD	1	EB,GC,SG,GCT					
△ 407	K2CJ2DA00008	AC CORD	1	GN					
△ 407	K2CA2CA00029	AC CORD	1	PL					
△ 407	K2CA2CA00027	AC CORD	1	GT					
△ 407	K2CA2CA00020	AC CORD	1	GK					
408	N2QAEC000016	REMOTE CONTROLLER	1						
409	VYF2992	HOOD CAP UNIT	1						
410	N2QCAD000007	REMOTE CONTROL ASSY	1						
411	VFA0453	USB CABLE	1						
△ 412	VQT0T35	OPERATING INSTRUCTIONS (GERMAN/ITALIAN)	1	EG					
△ 412	VQT0T36	OPERATING INSTRUCTIONS (FRENCH/DUTCH)	1	EG					
△ 412	VQT0T41	OPERATING INSTRUCTIONS (ENGLISH)	1	EB					
△ 412	VQT0T39	OPERATING INSTRUCTIONS (ENGLISH/POLISH)	1	EP					
△ 412	VQT0T40	OPERATING INSTRUCTIONS (CZECH/HUNGARY)	1	EP					
△ 412	VQT0T45	OPERATING INSTRUCTIONS (RUSSIAN/UKRAINIAN)	1	EE					
△ 412	VQT0T37	OPERATING INSTRUCTIONS (PORTUGUESE/SPANISH)	1	E					
△ 412	VQT0T38	OPERATING INSTRUCTIONS (SWEDISH/DANISH)	1	E					
△ 412	VQT0T42	OPERATING INSTRUCTIONS (CHINESE/ENGLISH)	1	GC,SG					
△ 412	VQT0T43	OPERATING INSTRUCTIONS (ARABIC/PERSIAN)	1	GC,SG					
△ 412	VQT0T47	OPERATING INSTRUCTIONS (ENGLISH)	1	GN					
△ 412	VQT0W31	OPERATING INSTRUCTIONS (ENGLISH)	1	GCT					
△ 412	VQT0W32	OPERATING INSTRUCTIONS (ENGLISH)	1	GCT					
△ 412	VQT0V38	OPERATING INSTRUCTIONS (ENGLISH)	1	PL					
△ 412	VQT0T34	OPERATING INSTRUCTIONS (CHINESE)	1	GT					
△ 412	VQT0T48	OPERATING INSTRUCTIONS (CHINESE/ENGLISH)	1	GK					
413	VQT0T12	O/I CD-ROM (GE/FR/IT/DU)	1	EG					
413	VQT0T20	O/I CD-ROM (EN)	1	EB,GN					
413	VQT0T18	O/I CD-ROM (EN/PO/CZ/HU)	1	EP					
413	VQT0T27	O/I CD-ROM (RUSSIAN)	1	EE					
413	VQT0T15	O/I CD-ROM (PR/SP/SW/DA)	1	E					
413	VQT0T23	O/I CD-ROM (CO/EN/PE/AR)	1	GC,SG					
413	VQT0W30	O/I CD-ROM (EN)	1	GCT					
413	VQT0V33	O/I CD-ROM (EN)	1	PL					
413	VQT0T09	O/I CD-ROM (CO)	1	GT					
413	VQT0T31	O/I CD-ROM (CN)	1	GK					
△ 414	VSK0651B	AC ADAPTOR	1	EG,EB,EP,EE,E,GC,GN, SG,GCT,PL					
△ 414	VSK0679	AC ADAPTOR	1	GT					
△ 414	VSK0651A	AC ADAPTOR	1	GK					
415	VFF0305-S	CD-ROM	1	SEE "NOTES"					
416	VFC3506-1A	SHOULDER BELT	1						

S7. Exploded View

S7.1. Frame and Casing Section (1)

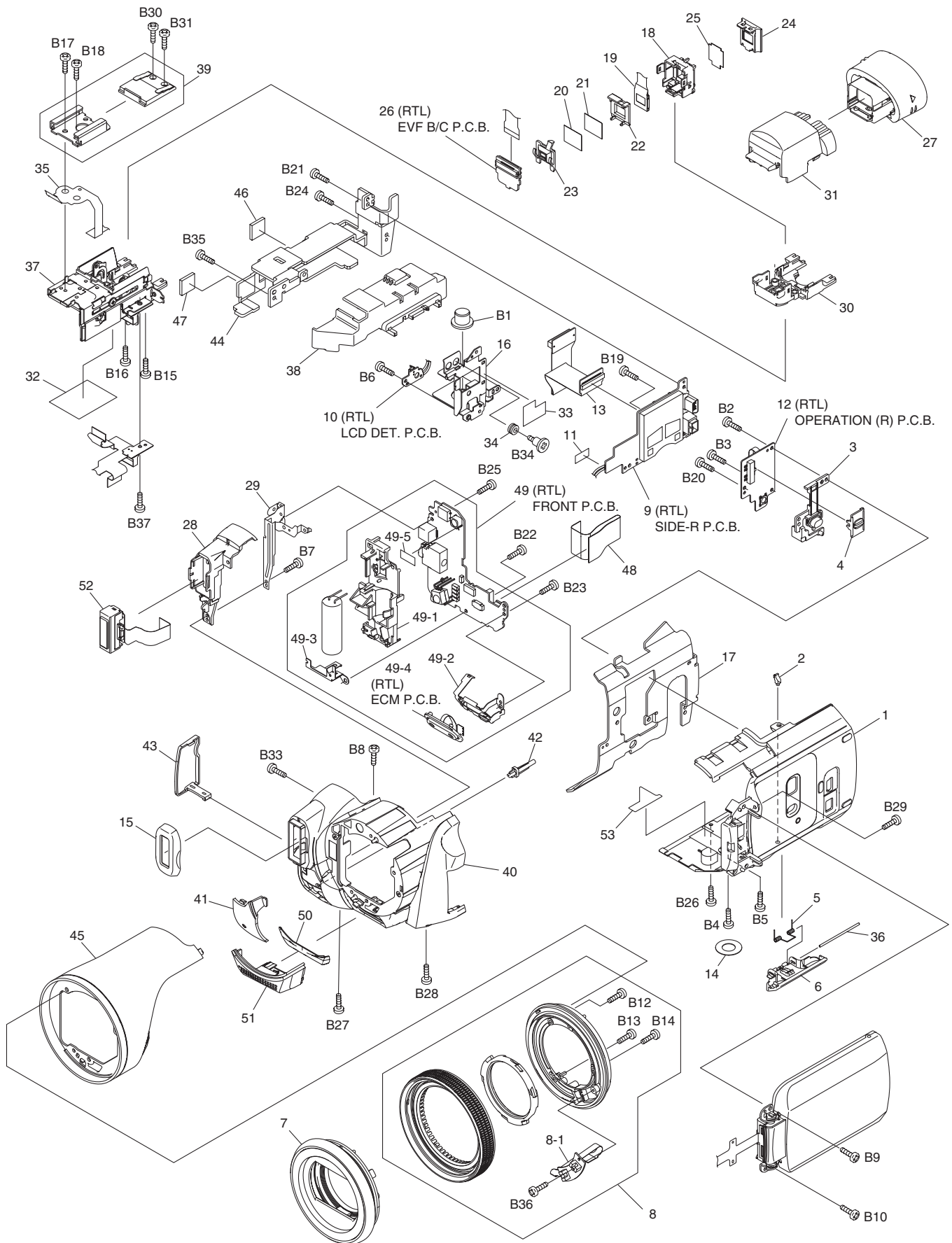

S7.2. Frame and Casing Section (2)

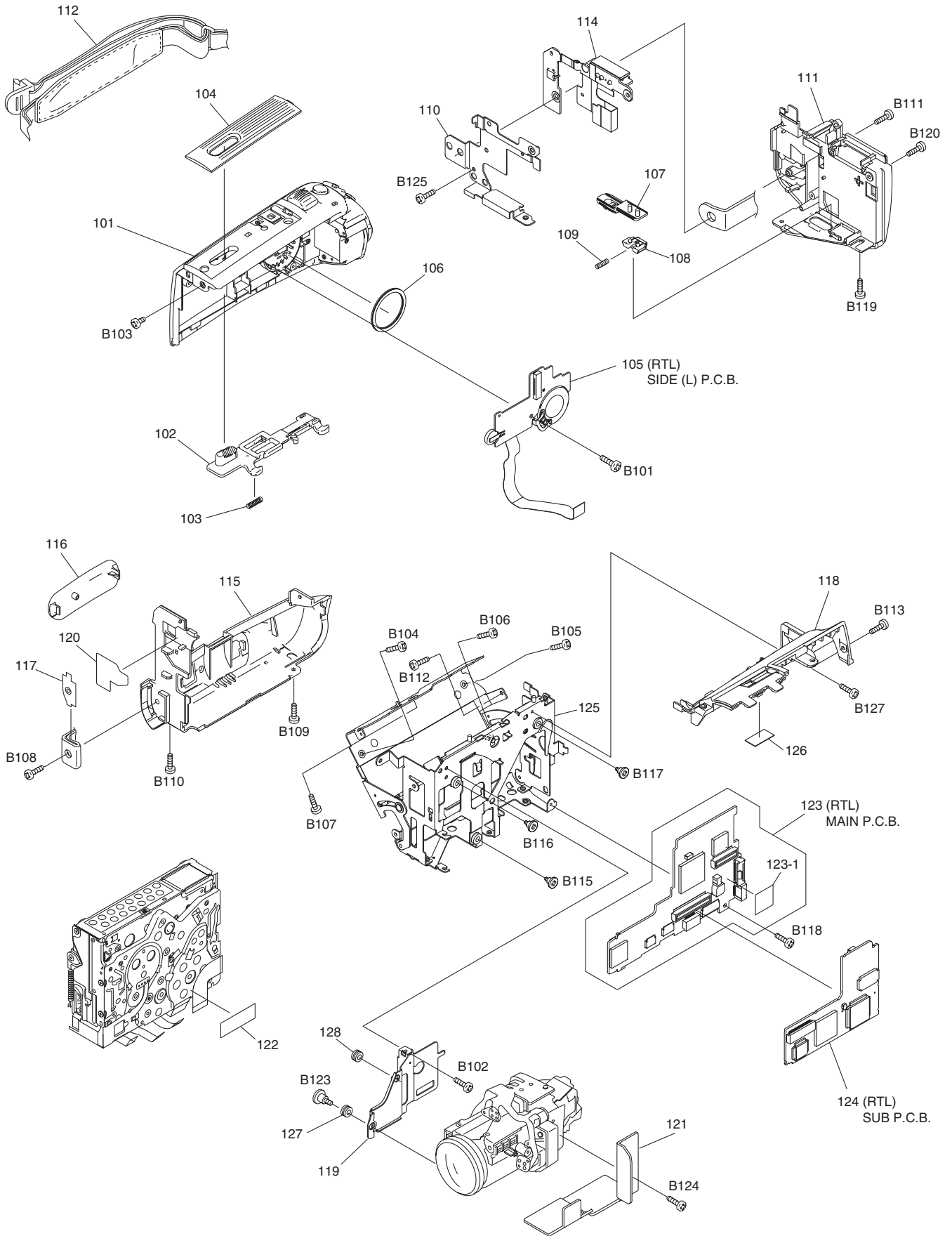

S7.3. LCD Section

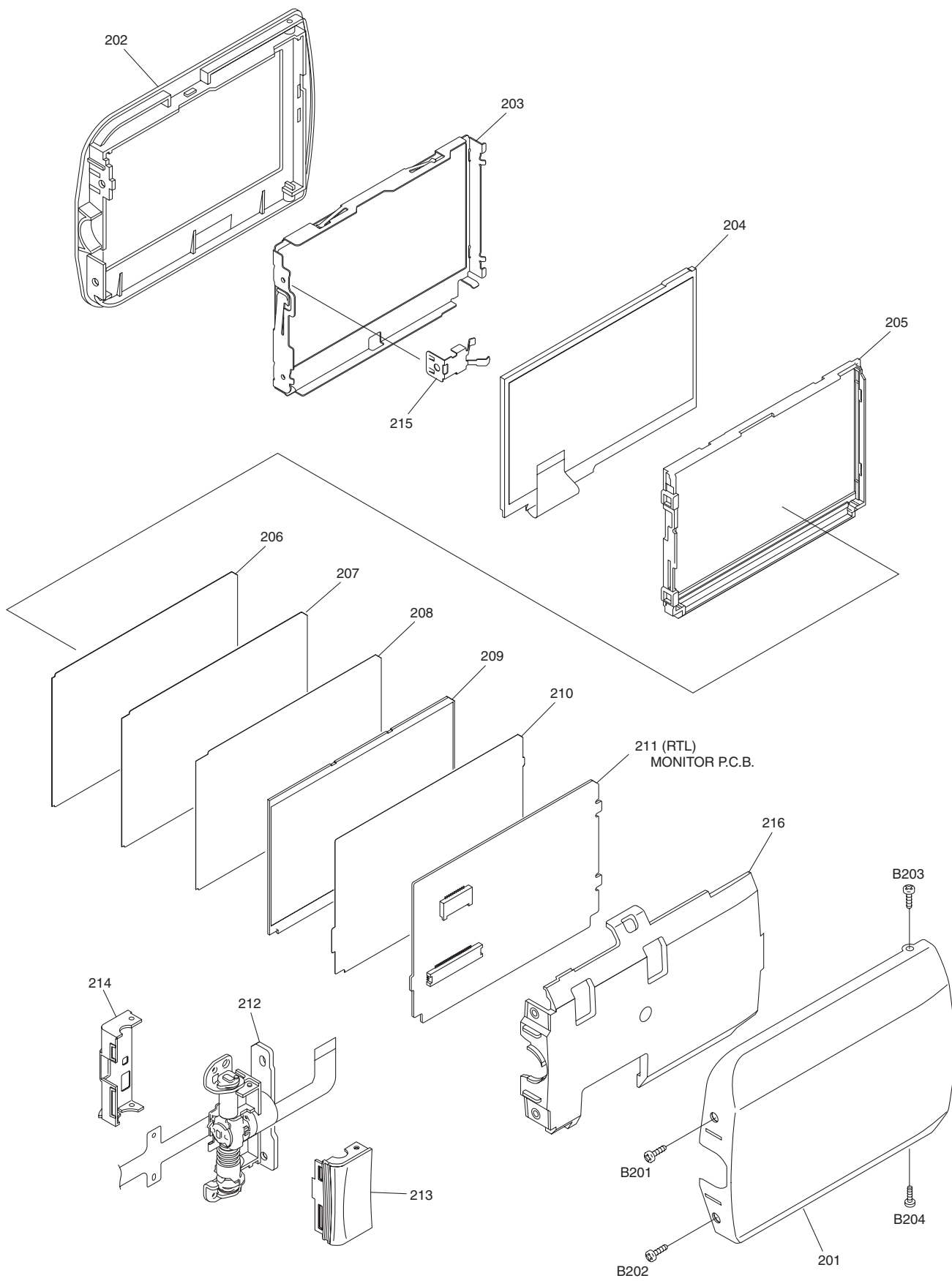

S7.5. Video Mechanism Section

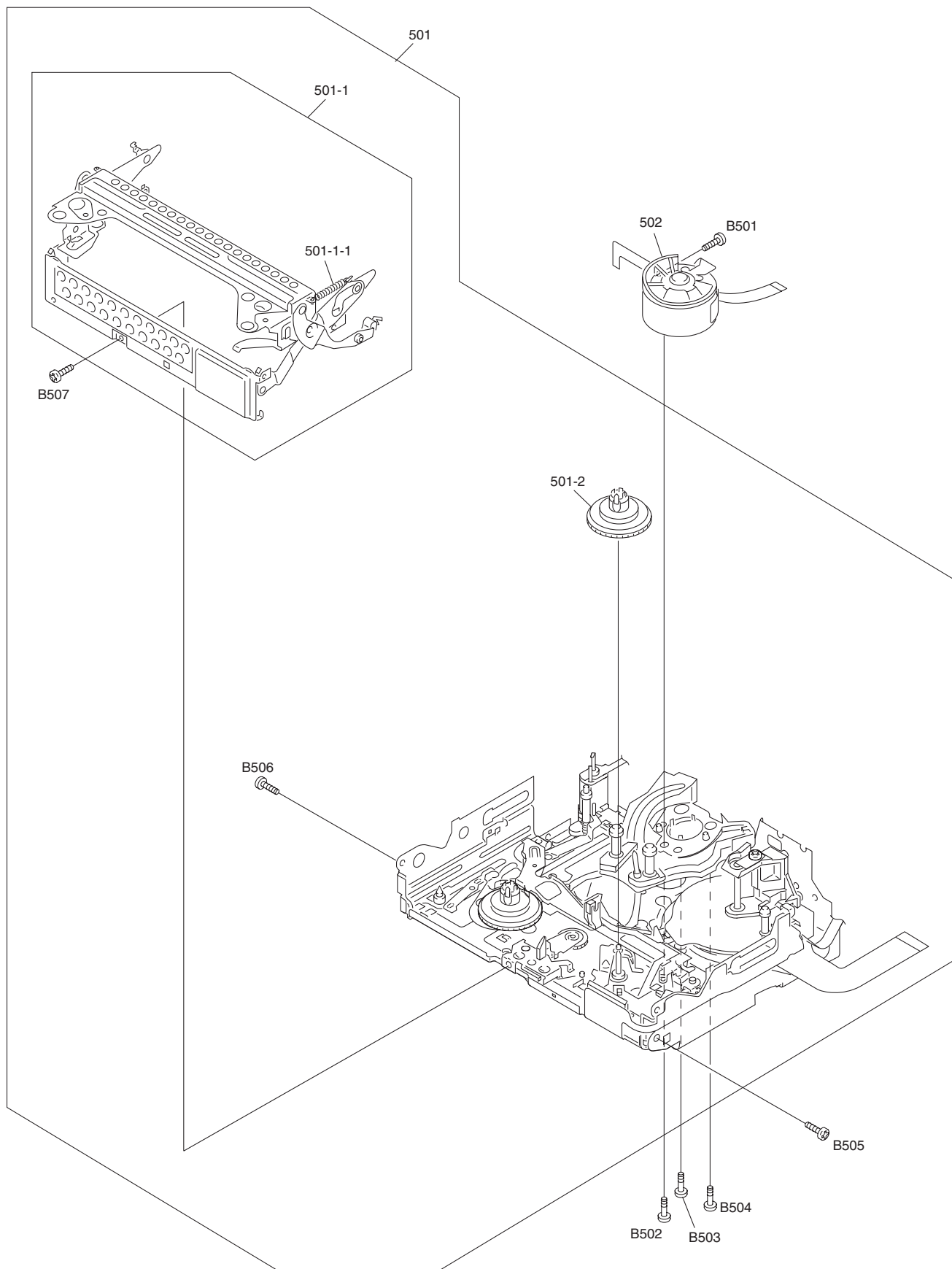

S7.6. Packing Parts and Accessories Section

