

Service Manual

Digital Video Camcorder

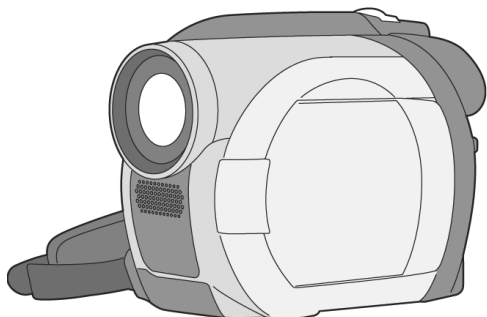

PbF
Solder Lead free

VDR-D100EB VDR-D100EG
VDR-D150E VDR-D150EB
VDR-D150EE VDR-D150EF
VDR-D150EG VDR-D150EP
VDR-D150GC VDR-D150GCS
VDR-D150GN VDR-D150SG
VDR-D152EG VDR-D158GK

Vol. 1

Colours

(S).....Silver Type

WARNING

This service information is designed for experienced repair technicians only and is not designed for use by the general public. It does not contain warnings or cautions to advise non-technical individuals of potential dangers in attempting to service a product. Products powered by electricity should be serviced or repaired only by experienced professional technicians. Any attempt to service or repair the product or products dealt with in this service information by anyone else could result in serious injury or death.

Panasonic

© 2006 Matsushita Electric Industrial Co., Ltd. All rights reserved. Unauthorized copying and distribution is a violation of law.

CONTENTS

	Page		Page
1 Safety Precautions	3	10.2. Cleaning disc and optical pickup	49
1.1. General Guidelines	3	11 Block Diagrams	51
2 Warning	4	12 Schematic Diagrams	61
2.1. Prevention of Electro Static Discharge (ESD) to Electrostatically Sensitive (ES) Devices	4	12.1. SCHEMATIC DIAGRAM & CIRCUIT BOARD LAYOUT NOTES	61
2.2. Caution for AC Cord (VJA0940 type)	5	12.2. FRONT SCHEMATIC DIAGRAM	62
2.3. How to Replace the Lithium Battery	6	12.3. SIDE R SCHEMATIC DIAGRAM	63
3 Service Navigation	7	12.4. LCD BACKLIGHT SCHEMATIC DIAGRAM	64
3.1. Introduction	7	12.5. JACK / EVF BACKLIGHT / DISK COVER LOCK SCHEMATIC DIAGRAMS	65
3.2. About Lead Free Solder (PbF)	7	12.6. CCD / LCD SW / SIDE L/DISK SCHEMATIC DIAGRAMS	66
4 Specifications	8	12.7. INTERCONNECTION SCHEMATIC DIAGRAM	67
5 Location of Controls and Components	9	12.8. VOLTAGE CHART	68
6 Service Mode	21	13 Printed Circuit Board	69
6.1. Error Display	21	13.1. FRONT P.C.B.	69
6.2. Service Menu	21	13.2. JACK P.C.B.	70
7 Service Fixture & Tools	23	13.3. LCD BACKLIGHT P.C.B.	71
7.1. Service Fixture and Tools	23	13.4. SIDE R P.C.B. / OPEN SWITCH P.C.B.	72
7.2. Service Position	24	14 Exploded View	73
7.3. Removal/Installation of F.P.C. From Non ZIF (Zero Insertion Force) Connector	26	14.1. MAIN PARTS SECTION	73
7.4. Method for Ejecting the DVD Tray Manually	27	14.2. FRONT CASE, MAIN P.C.B. AND JACK P.C.B. SECTION	74
7.5. EEPROM Data	27	14.3. SIDE CASE R AND LCD SECTION	75
7.6. Special Note	28	14.4. CCD AND LENS SECTION	76
7.7. IC6001 REPLACEMENT NOTE	28	14.5. REAR CASE AND EVF SECTION	77
8 Disassembly and Assembly Instructions	29	14.6. PACKING PARTS AND ACCESSORIES SECTION	78
8.1. Cabinet Section	29	15 Replacement Parts Lists	79
9 Measurements and Adjustments	47	15.1. MECHANICAL REPLACEMENT PARTS LIST	79
9.1. Electrical Adjustment	47	15.2. ELECTRICAL REPLACEMENT PARTS LIST	81
10 Maintenance	49		
10.1. Cleaning Lens, Viewfinder and LCD Panel	49		

1 Safety Precautions

1.1. General Guidelines

1. IMPORTANT SAFETY NOTICE

There are special components used in this equipment which are important for safety. These parts are marked by \triangle in the Schematic Diagrams, Circuit Board Layout, Exploded Views and Replacement Parts List. It is essential that these critical parts should be replaced with manufacturer's specified parts to prevent shock, fire, or other hazards. Do not modify the original design without permission of manufacturer.

2. An Isolation Transformer should always be used during the servicing of AC Adaptor whose chassis is not isolated from the AC power line. Use a transformer of adequate power rating as this protects the technician from accidents resulting in personal injury from electrical shocks. It will also protect AC Adaptor from being damaged by accidental shorting that may occur during servicing.
3. When servicing, observe the original lead dress. If a short circuit is found, replace all parts which have been overheated or damaged by the short circuit.
4. After servicing, see to it that all the protective devices such as insulation barriers, insulation papers shields are properly installed.
5. After servicing, make the following leakage current checks to prevent the customer from being exposed to shock hazards.

2 Warning

2.1. Prevention of Electro Static Discharge (ESD) to Electrostatically Sensitive (ES) Devices

Some semiconductor (solid state) devices can be damaged easily by static electricity. Such components commonly are called Electrostatically Sensitive (ES) Devices. Examples of typical ES devices are integrated circuits and some field-effect transistors and semiconductor "chip" components. The following techniques should be used to help reduce the incidence of component damage caused by electro static discharge (ESD).

1. Immediately before handling any semiconductor component or semiconductor-equipped assembly, drain off any ESD on your body by touching a known earth ground. Alternatively, obtain and wear a commercially available discharging ESD wrist strap, which should be removed for potential shock reasons prior to applying power to the unit under test.
2. After removing an electrical assembly equipped with ES devices, place the assembly on a conductive surface such as aluminum foil, to prevent electrostatic charge buildup or exposure of the assembly.
3. Use only a grounded-tip soldering iron to solder or unsolder ES devices.
4. Use only an antistatic solder removal device. Some solder removal devices not classified as "antistatic (ESD protected)" can generate electrical charge sufficient to damage ES devices.
5. Do not use freon-propelled chemicals. These can generate electrical charges sufficient to damage ES devices.
6. Do not remove a replacement ES device from its protective package until immediately before you are ready to install it. (Most replacement ES devices are packaged with leads electrically shorted together by conductive foam, aluminum foil or comparable conductive material).
7. Immediately before removing the protective material from the leads of a replacement ES device, touch the protective material to the chassis or circuit assembly into which the device will be installed.

CAUTION :

Be sure no power is applied to the chassis or circuit, and observe all other safety precautions.

8. Minimize bodily motions when handling unpackaged replacement ES devices. (Otherwise harmless motion such as the brushing together of your clothes fabric or the lifting of your foot from a carpeted floor can generate static electricity (ESD) sufficient to damage an ES device).

2.2. Caution for AC Cord (VJA0940 type)

2.2.1. Information for your safety

IMPORTANT

Your attention is drawn to the fact that recording of pre-recorded tapes or discs or other published or broadcast material may infringe copyright laws.

WARNING

To reduce the risk of fire or shock hazard, do not expose this equipment to rain or moisture.

CAUTION

To reduce the risk of fire or shock hazard and annoying interference, use the recommended accessories only.

FOR YOUR SAFETY

DO NOT REMOVE THE OUTER COVER

To prevent electric shock, do not remove the cover. No user serviceable parts inside. Refer servicing to qualified service personnel.

2.2.2. Caution for AC Mains Lead

For your safety, please read the following text carefully.

This appliance is supplied with a moulded three-pin mains plug for your safety and convenience.

A 5-ampere fuse is fitted in this plug.

Should the fuse need to be replaced please ensure that the replacement fuse has a rating of 5 amperes and it is approved by ASTA or BSI to BS1362.

Check for the ASRA mark or the BSI mark on the body of the fuse.



If the plug contains a removable fuse cover you must ensure that it is refitted when the fuse is replaced.

If you lose the fuse cover, the plug must not be used until a replacement cover is obtained.

A replacement fuse cover can be purchased from your local Panasonic Dealer.

If the fitted moulded plug is unsuitable for the socket outlet in your home then the fuse should be removed and the plug cut off and disposed of safely.

There is a danger of severe electrical shock if the cut off plug is inserted into any 13-ampere socket.

If a new plug is to be fitted please observe the wiring code as shown below.

If in any doubt, please consult a qualified electrician.

2.2.2.1. Important

The wires in this mains lead are coloured in accordance with the following code:

Blue	Neutral
Brown	Live

As the colours of the wires in the mains lead of this appliance may not correspond with the coloured markings identifying the terminals in your plug, proceed as follows:

The wire which is coloured BLUE must be connected to the terminal in the plug which is marked with the letter N or coloured BLACK.

The wire which is coloured BROWN must be connected to the terminal in the plug which is marked with the letter L or coloured RED.

Under no circumstances should either of these wires be connected to the earth terminal of the three pin plug, marked with the letter E or the Earth Symbol.

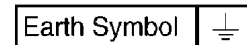

2.2.2.2. Before use

Remove the Connector Cover as follows.

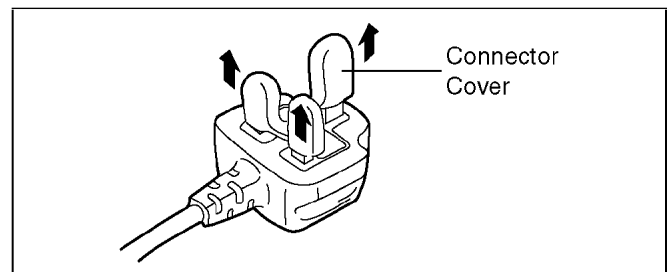

2.2.2.3. How to replace the Fuse

1. Remove the Fuse Cover with a screwdriver.

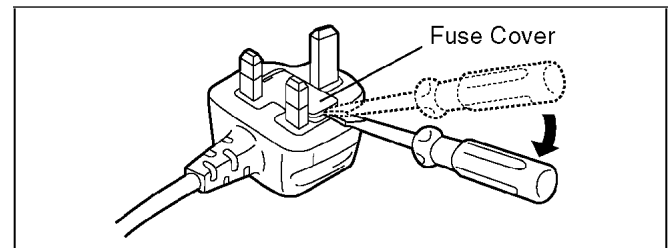

2. Replace the fuse and attach the Fuse cover.

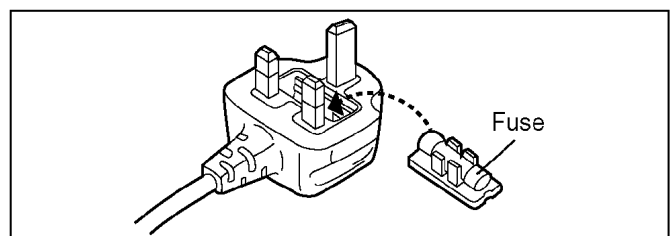

2.3. How to Replace the Lithium Battery

The lithium battery (ML-621S/F9D) is not supplied as a service part and must be replaced as part of the Cassette Cover Unit. (Refer to "Disassembly and Assembly Instructions.")

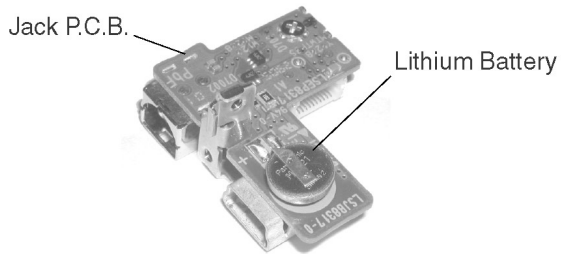

Danger of explosion if battery is incorrectly replaced.
Replace only with the same or equivalent type.

CAUTION - The battery used in this device may present a risk of fire or chemical burn if mistreated.
Do not recharge, disassemble, heat above 100 °C (212 °F), or incinerate.
Replace battery with Panasonic part number ML-621S/F9D only.
Use of another battery may present a risk of fire or explosion.
Dispose of used battery promptly. Keep away from children.
Do not disassemble and do not dispose of in fire.

NOTE:

This Lithium battery is a critical component. (Type No.: ML-621S/F9D Manufactured by Panasonic.) **(Not supplied)**

It must never be subjected to excessive heat or discharge.

It must therefore only be fitted in equipment designed specifically for its use.

Replacement batteries must be of the same type and manufacture.

They must be fitted in the same manner and location as the original battery, with the correct polarity contacts observed.

Do not attempt to re-charge the old battery or re-use it for any other purpose.

It should be disposed of in waste products destined for burial rather than incineration.

CAUTION

Danger of explosion if battery is incorrectly replaced.
Replace only with the same or equivalent type recommended by the equipment manufacturer.
Discard used batteries according to manufacturer's instructions.

PRECAUTION

Le fait de remplacer incorrectement la pile peut présenter des risques d'explosion.
Remplacer la pile uniquement par une pile identique ou de type équivalent recommandée par le fabricant. Se débarrasser des piles usagées conformément aux instructions du fabricant.

VORSICHT

Bei einer falsch eingesetzten Batterie besteht Explosionsgefahr. Nur mit einer vom Hersteller empfohlenen Batterie vom gleichen Typ ersetzen.
Verbrauchte Batterien beim Fachhändler oder einer Sammelstelle für Sonderstoffe abliefern.

VARNING

Explosionsfara vid felaktigt batteribyte.
Använd samma batterityp eller en ekvivalent typ som rekommenderas av apparattillverkaren.
Kassera använt batteri enligt fabrikantens instruktion.

ADVARSEL!

Lithiumbatteri-Eksplosionsfare ved fejlagtig håndtering.
Udskiftning må kun ske med batteri af samme fabrikat og type.
Levér det brugte batteri tilbage til leverandøren.

VAROITUS

Paristo voi räjähtää, jos se on virheellisesti asennettu.
Vaihda paristo ainoastaan laitevalmistajan suositteluun tyyppiin.
Hävitätä käytetty paristo valmistajan ohjeiden mukaisesti.

3 Service Navigation

3.1. Introduction

This service manual contains technical information which will allow service personnel's to understand and service this model. Please place orders using the parts list and not the drawing reference numbers.

If the circuit is changed or modified, this information will be followed by supplement service manual to be filed with original service manual.

Note 1:

1. VSK0561 is indicated on the AC Adaptor used in the following model:

VDR-D158GK.

However, the AC Adaptor replacement part number is DE-974HA which should be used when ordering.

2. VSK0561 is indicated on AC Adaptor used in the following models:

VDR-D100EB, VDR-D100EG, VDR-D150E, VDR-D150EB, VDR-D150EE, VDR-D150EF, VDR-D150EG, VDR-D150EP, VDR-D150GC, VDR-D150GCS, VDR-D150GN, VDR-D150SG, and VDR-D152EG.

However, the AC Adaptor replacement part number is DE-974GB which should be used when ordering.

Note 2:

1. This service manual does not contain the following information, because of the impossibility of servicing at component level.

a. Schematic Diagram, Block Diagram and P.C.B. layout of Main P.C.B.

b. Parts List for individual parts of Main P.C.B.

2. The following category are recycle module parts. Please send it to Central Repair Center.

a. *Main P.C.B. (LSEP8314P1/ LSEP8314Q1)

When a part replacement is required for repairing Main P.C.B., replace the assembly parts.

3.2. About Lead Free Solder (PbF)

Distinction of PbF PCB:

PCBs (manufactured) using lead free solder will have a PbF stamp on the PCB.

Caution:

• Pb free solder has a higher melting point than standard solder; Typically the melting point is 50-70°F (30-40°C) higher.

Please use a high temperature soldering iron. In case of the soldering iron with temperature control, please set it to 700±20°F (370±10°C).

• Pb free solder will tend to splash when heated too high (about 1100°F/600°C).

When soldering or unsoldering, please completely remove all of the solder on the pins or solder area, and be sure to heat the soldering points with the Pb free solder until it melts enough.

4 Specifications

ITEM	SPECIFICATION	1	2	ITEM	SPECIFICATION	1	2	
Power	DVD Video Camera: Power source: DC 7.9 V/7.2 V Power consumption: Recording Approx. 3.9 W (When using viewfinder) Approx. 4.3 W (When using LCD monitor) (When using a DVD-RAM disc and the recording mode is [XP].)	○	○	Video output level	1.0 Vp-p 75 Ω	○	○	
	AC adaptor: Power source: AC 110 V to 240 V, 50/60 Hz Power consumption: 19 W DC output: DC 7.9 V, 1.4 A (Unit operation) DC 8.4 V, 0.65 A (Battery charging)			S-Video output level	Y: 1.0 Vp-p, 75 Ω C: 0.3 Vp-p, 75 Ω			
	Audio output level (Line)			316 mV, 600 Ω				
	USB			Card reader/writer function (No copyright protection support) USB 2.0 compliant (Hi-Speed) PictBridge-compliant	-			○
	Motion pictures			Recording media: 8 cm DVD-RAM Ver. 2.1 8 cm DVD-RW Ver. 1.1/2X-SPEED (2X/1X) 8 cm DVD-R for General Ver. 2.0 Compression: MPEG2 Recording mode and transfer rate: XP: 9 Mbps (VBR) SP: 5 Mbps (VBR) LP: 2.5 Mbps (VBR) Audio compression: Dolby Digital (Dolby AC3), 16 bit (48 kHz/2 ch)	○			○
Signal system	CCIR: 625 lines, 50 fields PAL colour signal	○	○	Still pictures	Recording media: SD Memory Card (8 MB/16 MB/32 MB/64 MB/ 128 MB/256 MB/512 MB/1 GB/2 GB (Maximum)) Compression: JPEG (Design rule for Camera File system, based on Exif 2.2 standard), DPOF corresponding Picture size: 640 × 480	-	○	
Recording format	DVD Video Recording format (DVD-RAM, DVD-RW) DVD-Video format (DVD-RW, DVD-R)	○	○	Operating temperature	0 °C to 40 °C	○	○	
Image sensor	1/6-inch CCD image sensor Total pixels: approx. 800 K Effective pixels (Motion picture): approx. 400 K	○	○	Operating humidity	10% to 80%	○	○	
Lens	30x power zoom F1.8 to F3.9 (f = 1.90 mm to 57.0 mm, 35 mm equivalent: 35.7 mm to 1072 mm)	○	○	Mass	DVD Video Camera: 480 g (without supplied battery, lens cap and a disc) AC adaptor: 110 g	○	○	
Filter diameter	30.5 mm	○	○	Dimensions	DVD Video Camera: 53 mm (W) × 87 mm (H) × 129 mm (D) (excluding projecting parts) AC adaptor: 61 mm (W) × 32 mm (H) × 91 mm (D)	○	○	
Zoom	30x optical zoom, 50/1000x digital zoom	○	○	Solder	This model uses lead free solder (PbF).	○	○	
Monitor	2.5" LCD monitor (approx. 105 K pixels)	○	○					
Viewfinder	Colour electric viewfinder (approx. 123 K pixels)	○	○					
Microphone	Stereo (with a zoom function)	○	○					
Speaker	1 round speaker ∅20 mm	○	○					
Standard illumination	1,400 lx	○	○					
Minimum required illumination	12 lx (2 lx with the Night view function)	○	○					

- VDR-D100EB/ VDR-D100EG
- VDR-D150E/ VDR-D150EB/ VDR-D150EE/ VDR-D150EF/
VDR-D150EG/ VDR-D150EP/ VDR-D150GC/ VDR-D150GCS/
VDR-D150GN/ VDR-D150SG/ VDR-D152EG/ VDR-D158GK

Mass and dimensions are approximate values.
Specifications may change without prior notice.

5 Location of Controls and Components

Followings are the Operation Guide for VDR-D100EB/D150EB as a sample.

For other models, refer to each original Operation Guide.

Features

Features

■ Easy recording! (→ 39)

No need to search for the recording start position.
The new recording will not overwrite any previously recorded scene.

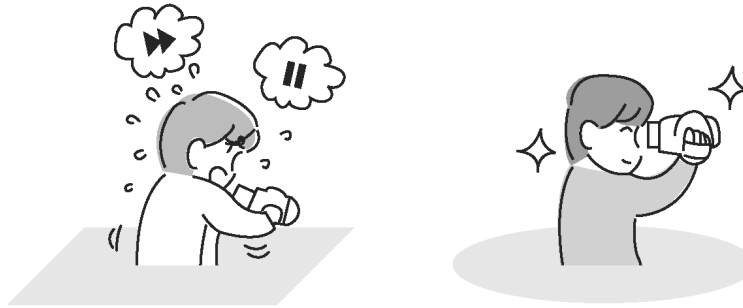

■ Easy playback! (→ 62)

Recorded scenes are displayed as thumbnails.
You can easily search for the scenes you want to watch.

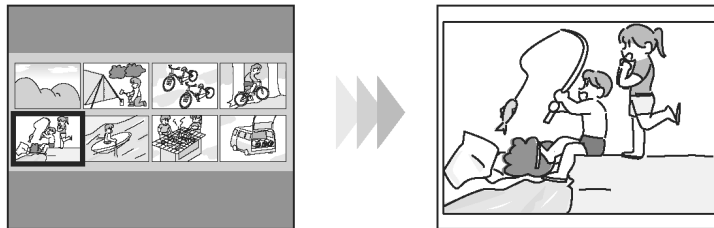

Before using

Features

■ Editing scenes! (→ 67, 71)

You can create an original video (playlist) by collecting your favourite scenes together and then easily dub this video to a VCR or a DVD recorder hard disk.

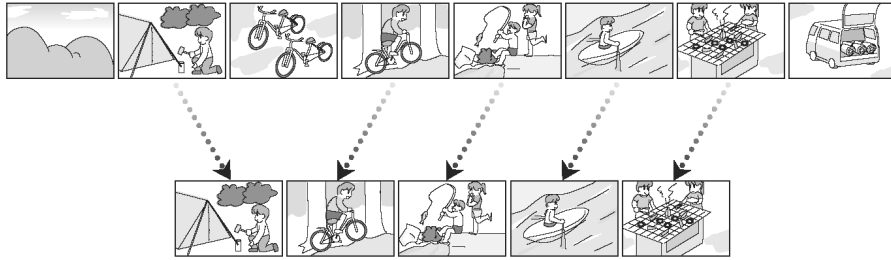

■ Using with DVD player/recorder! (→ 91)

Just insert the disc into a DVD player/recorder compatible with 8 cm discs to play back the scenes recorded with this unit on it.

If you have a DVD recorder with hard disk, you can dub scenes recorded on DVD-RAM or DVD-RW (VR format) with this unit to the hard disk.

Before using

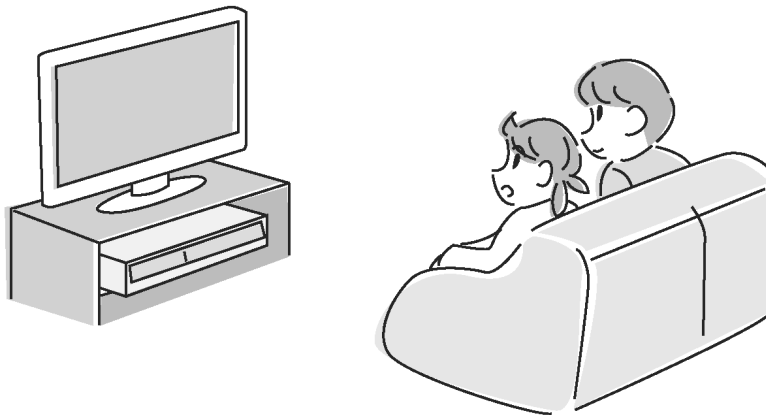

■ Sales and Support Information

Customer Care Centre

- For customers within the UK: 08705 357357
- For customers within the Republic of Ireland: 01 289 8333
- Visit our website for product information
- E-mail: customer.care@panasonic.co.uk

Technical Support for AV Software

- For UK, ROI: 08701 505610

Direct Sales at Panasonic UK

- Order accessory and consumable items for your product with ease and confidence by phoning our Customer Care Centre Monday–Thursday 9.00 a.m.–5.30 p.m., Friday 9.30 a.m.– 5.30 p.m. (Excluding public holidays)
- Or go on line through our Internet Accessory ordering application at www.panasonic.co.uk.
- Most major credit and debit cards accepted.
- All enquiries transactions and distribution facilities are provided directly by Panasonic UK Ltd.
- It couldn't be simpler!
- Also available through our Internet is direct shopping for a wide range of finished products, take a browse on our website for further details.

Accessories

Check the accessories before using this unit.

Battery pack

CGA-DU12



AC adaptor

VSK0651B
(DE-974GB)



DC cable

K2GJ2DC00011



AV/S cable

K2KZ9CB00001



Disc cleaning cloth

VFC3778-2



AC cable

K2CT3CA00004
(RJA0053-3X)



Before using

Optional accessories

AC adaptor (VW-AD11EB)	MC protector (VW-LMC30E)
Battery pack (lithium/CGA-DU12/1150 mAh)	Tripod (VW-CT45E)
Battery pack (lithium/CGA-DU14/1360 mAh)	8 cm DVD-RAM disc (single sided/LM-AF30E)
Battery pack (lithium/CGA-DU21/2040 mAh)	8 cm DVD-RAM disc (double sided/LM-AF60E)
Wide conversion lens (VW-LW3007E)	8 cm DVD-RW disc (single sided/LM-RW30E)
Tele conversion lens (VW-LT3014E)	8 cm DVD-RW disc (double sided/LM-RW60E)
ND filter (VW-LND30E)	8 cm DVD-R disc (single sided/LM-RF30E)
USB cable (K1HA05CD0010)	Shoulder strap (VFC3506-1A)
DVD Movie Album SE4 (VW-DTD10E)	

- Some optional accessories may not be available in some countries.

Parts identification and handling

- 1 Lens
- 2 Microphone (built-in, stereo)
- 3 White balance sensor (→ 60)
- 4 Terminal cover
- 5 Audio-video output terminal [A/V] (→ 90, 93)
- 6 USB terminal [↔] (→ 94)
 - When you are operating this unit with a computer, we recommend an operating environment less than approximately 30 °C and an operating time of approximately 30 minutes.
- 7 Viewfinder (→ 13, 37)

Due to limitations in LCD production technology, there may be some tiny bright or dark spots on the viewfinder screen. However, this is not a malfunction and does not affect the recorded picture.

- 8 LCD monitor open button [PUSH OPEN] (→ 13)
- 9 DC input terminal [DC/C.C. IN] (→ 22)
- 10 Recording start/stop button (→ 39)
- 11 Power switch [OFF/ON] (→ 23)
- 12 Status indicator (→ 23)
- 13 Mode dial (→ 27)
- 14 Joystick (→ 28)
 - Move up, down, left or right to select items.
 - Press the centre to enter the selection.
- 15 Delete button [⏏] (→ 67, 78, 80)
- 16 Menu button [MENU] (→ 33)
- 17 Battery holder (→ 20)
- 18 Eyepiece corrector knob (→ 37)
- 19 Zoom lever [W/T] (→ 44)
 - Volume lever [-VOLUME+] (→ 63)
- 20 Photo shot button [PHOTO SHOT] (VDR-D150 only) (→ 42)
- 21 Card access lamp (VDR-D150 only) (→ 26)
- 22 Card slot cover (VDR-D150 only) (→ 26)
- 23 Card slot (VDR-D150 only) (→ 26)
- 24 Tripod receptacle (→ 12)
- 25 Battery release lever [BATTERY RELEASE] (→ 20)

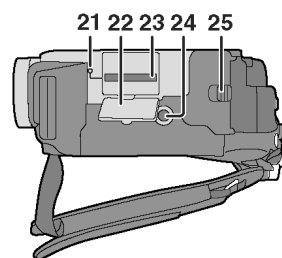
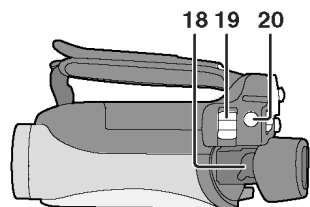
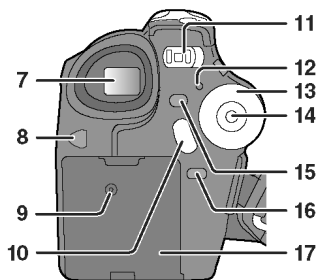
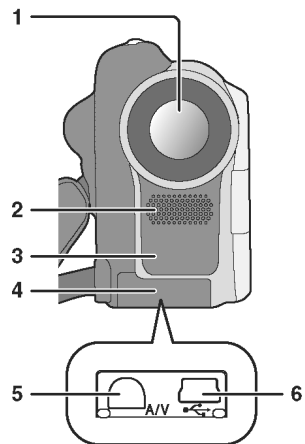

Before using

Parts identification and handling

26 Reset button [RESET] (→ 109)

27 LCD monitor (→ 13)

Due to limitations in LCD production technology, there may be some tiny bright or dark spots on the LCD monitor screen. However, this is not a malfunction and does not affect the recorded picture.

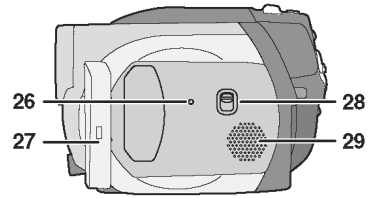

28 Mode select switch [AUTO/MANUAL/FOCUS] (→ 56)

29 Speaker

30 Disc eject lever [DISC EJECT] (→ 24)

31 Disc access lamp [ACCESS/PC] (→ 24)

32 Disc compartment (→ 24)

33 Grip belt (→ below)

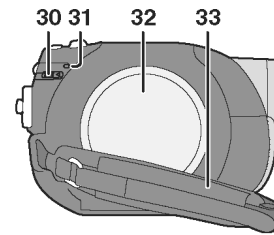

Using grip belt

Adjust the belt length so it fits your hand.

Adjust the belt length and the pad position.

- 1 Flip the belt.
- 2 Adjust the length.
- 3 Fix the belt.

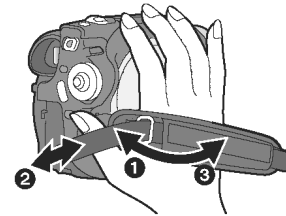

Before using

Parts identification and handling

Fitting the lens cap

Fit the lens cap to protect the surface of the lens.
The lens cap and lens cap cord comes preattached to the grip belt.

- When not using the lens cap, pull the lens cap cord in the direction of the arrow. **A**
- When you are not recording, be sure to cover the lens with the lens cap for protection. **B**

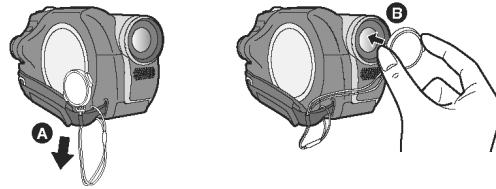

- When you remove the lens cap, press the knobs firmly.

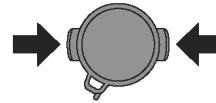

- If the lens cap cord has come off
Pass the end of the lens cap cord through the attached eye on the lens cap. Then pass the lens cap through the loop made by itself and pull tight.

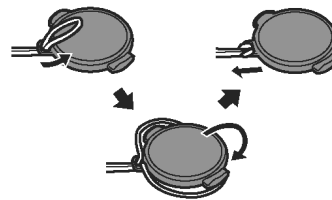

Before using

Tripod receptacle

This is a hole for attaching the unit to the optional tripod.
(Please carefully read the operating instructions for how to attach the tripod to the unit.)

- When the tripod is used, the card slot cover cannot be opened.
Insert an SD card before attaching this unit to the tripod. (→ 26)

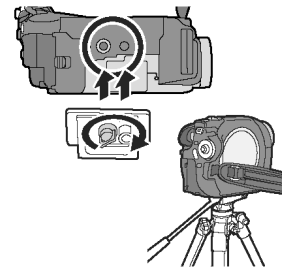

Using the LCD monitor

You can record the image while viewing it on the LCD monitor.

- 1 Press the PUSH OPEN button. The LCD monitor opens slightly. Pull the LCD monitor out in the direction of the arrow.**

- The viewfinder is now deactivated.
- It can open up to 90°.

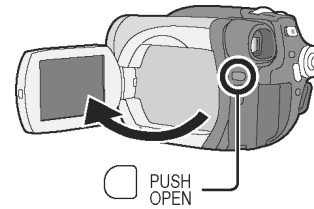

- 2 Adjust the angle of the LCD monitor according to your preference.**

- It can rotate up to 180° **A** towards the lens or 90° **B** towards the viewfinder.

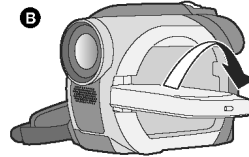
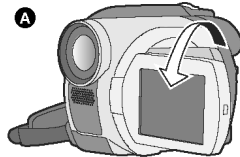

- The brightness and colour level of the LCD monitor can be adjusted from the menu. (→ 37)
- If it is forcibly opened or rotated, the unit may be damaged or fail.
- When the LCD monitor is rotated by 180° towards the lens (when recording yourself), the LCD monitor and the viewfinder will be simultaneously activated.

Using the viewfinder

Pull out the viewfinder until it clicks.

(→ 37, Adjusting viewfinder)

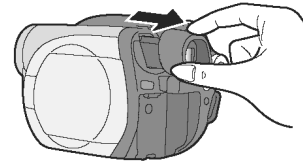











Before using

Discs and cards

Discs that can be used on this unit

Before using

Disc type	DVD-RAM 8 cm Single sided/ double sided	DVD-RW 8 cm Single sided/double sided		DVD-R 8 cm Single sided/ double sided
	 (DVD-RAM Ver. 2.1)	 [DVD-RW Ver. 1.1/ 2X-SPEED (2X/1X)]		 (DVD-R for General Ver. 2.0)
Recording format	DVD Video Recording format (VR format)	DVD Video Recording format (VR format)	DVD-Video format (Video format)	DVD-Video format (Video format)
Characteristic	Rewritable disc	Rewritable disc	One time recording disc*1	One time recording disc
Display on the screen				
Indication in these instructions				
Functions				
• Editing on this unit	●	●	—	—
• Playback on other products*2	●*3	●*4	●*5	●*5
• Recording after finalizing	—	●	●*6	—

●: available —: not available

*1 By formatting the disc, it can be used repeatedly. (→ 84)

*2 DVD players and DVD recorders that support 8 cm discs.

*3 Playback is possible on compatible products.

*4 Playback is possible on compatible products. (May have to be finalized on this unit.)

*5 Must be finalized on this unit. (→ 86)

*6 Un-finalize the disc. (→ 87)

- **Still pictures cannot be recorded on a disc with this unit.**
- When using double sided disc, you cannot record or play continuously from one side of the disc to the other. You will need to eject the disc and turn it over.
- Discs inserted in a holder, cartridge, or caddy case cannot be used. Always remove bare discs from these containers prior to use.
- It is recommended that you use Panasonic discs. Usually discs compatible with the DVD standard can be used for recording and playback with no problems. However, some commercially available discs do not meet the DVD standard for quality and performance. If you use one of these discs, you may not be able to record or playback normally. (The message "FOR BEST PERFORMANCE PANASONIC DISC IS RECOMMENDED." appears.) Refer to the following support site for information about discs that have been confirmed as compatible by Panasonic. http://panasonic.co.jp/pavc/global/cs/e_cam (This website is in English only.)
- Discs recorded on this unit may not be playable on other products.
- Recording on DVD-R in DVD Video Recording format is not supported.
- When using DVD-RW or DVD-R, do not perform the following, as doing so may make the disc unusable.
 - Record on a disc with other products after recording on it with this unit.
 - Record on a disc with this unit after recording on it with other products.
 - Insert an un-finalized disc in any other products.

■ About format types

What is the DVD Video Recording format (VR format)?

This is a format for recording on DVD discs which allows you to record and erase repeatedly and create playlists. You can record on DVD-RAM and DVD-RW in DVD Video Recording format with this unit.

What is the DVD-Video format (Video format)?

By finalizing the disc, it can be played back on most DVD players.

You can record on DVD-RW and DVD-R in DVD-Video format with this unit.

Before using

■ Examples of discs that cannot be used on this unit

- | | | |
|--|-------------|---------------|
| ● DVD-RAM (2.6 GB) Ver. 1.0 | ● DVD-ROM | ● MO |
| ● DVD-R (3.9 GB) Ver. 1.0 | ● DVD-Video | ● MD |
| ● DVD-R (4.7 GB) for Authoring Ver. 2.0 | ● CD-R | ● iD |
| ● +RW | ● CD-RW | ● Floppy disk |
| ● +R | ● CD | ● CD-ROM |
| ● DVD-R DL | ● LD | |
| ● Discs other than those with diameter of 8 cm | | |
| ● Dual/double layer discs | | |

When using brand-new DVD-RW

When using DVD-RW, select whether to record in DVD Video Recording format (VR format) or DVD-Video format (Video format) and then format the disc. (→ 15, About format types)

- 1 When a brand-new DVD-RW is inserted in this unit, the screen on the right appears. Select [YES], then press the joystick.**

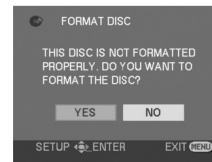

- 2 Select format type, then press the joystick.**

VIDEO: DVD-Video format

VR: DVD Video Recording format



- 3 When the confirm screen appears, select [YES], then press the joystick.**

- To change the format type, format the disc again. (→ 84)
If the disc is formatted, then all the data recorded on the disc will be erased.

Before using

Cards that you can use with this unit (VDR-D150 only)

Card type	SD Memory Card
Capacity	8 MB, 16 MB, 32 MB, 64 MB, 128 MB, 256 MB, 512 MB, 1 GB, 2 GB (Maximum)
Indication in these instructions	SD

- **Motion pictures cannot be recorded on an SD card with this unit.**
- Please confirm the latest information on the following website. (This website is in English only.)
http://panasonic.co.jp/pavc/global/cs/e_cam
- For the purposes of these operating instructions, SD Memory Card and miniSD™ Card are referred to as the "SD card".
- This unit supports SD cards formatted in FAT12 system and FAT16 system based on SD Memory Card Specifications.
- Use this unit to format SD cards. If an SD card is formatted on other products (such as a computer), the time spent for recording may become longer and you may not be able to use the SD card. (→ 85)
- We recommend that you use a Panasonic brand SD card.
- Be sure to insert miniSD™ Cards in the dedicated card adaptor before use. Inserting a card in this unit without the adaptor may damage the unit or the card.
- Do not insert an empty card adaptor in this unit. Do not leave the adaptor in this unit while inserting or removing miniSD™ Cards. This may cause the unit to malfunction.
- When the write-protect switch on SD Memory Card is locked, no recording, deletion or editing will be possible on the card.

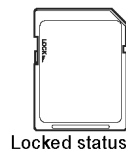
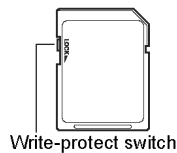

- Keep the memory card out of reach of children to prevent swallowing.
- A MultiMediaCard cannot be used on this unit.

Before using

Disc and card handling

■ How to hold a disc or card

Do not touch the recorded surface or the terminal surface.

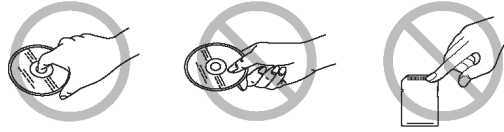

■ If there is dirt on the disc

Clean it with the supplied disc cleaning cloth. Wipe the disc from the centre to the outer edge to remove the dirt. Do not use force when wiping the disc as it may scratch it. Also, do not use solvents (thinner, water, antistatic agent, detergent etc.).



Before using

■ Handling precautions

- Be careful about scratches and dirt.
- Do not attach labels or stickers to discs.
(This may cause disc warping and un-balanced rotation, rendering it unusable.)
- Write on the label side of the disc only with a soft, oil-based felt pen. Do not use ballpoint pens or other hard writing implements.
- Do not use record cleaning sprays, benzene, thinner, static electricity prevention liquids or any other solvent.
- Do not use scratch-proof protectors or covers.
- Do not expose the terminals of the card to water, garbage or dust.
- Do not drop, stack, or impact discs. Do not place objects on them.
- Do not use the following discs:
 - Discs with exposed adhesive from removed stickers or labels.
 - Discs that are badly warped or cracked.
 - Irregularly shaped discs, such as heart shapes.
- Do not place in the following areas:
 - In direct sunlight.
 - In very dusty or humid areas.
 - Near a heater.
 - Locations susceptible to significant difference in temperature (condensation can occur).
 - Where static electricity or electromagnetic waves occur.
- To protect discs and cards, return them to their cases when you are not using them.



6 Service Mode

6.1. Error Display

"PUSH THE RESET SWITCH" is displayed automatically on the EVF or the LCD Monitor when an undesirable condition has occurred.

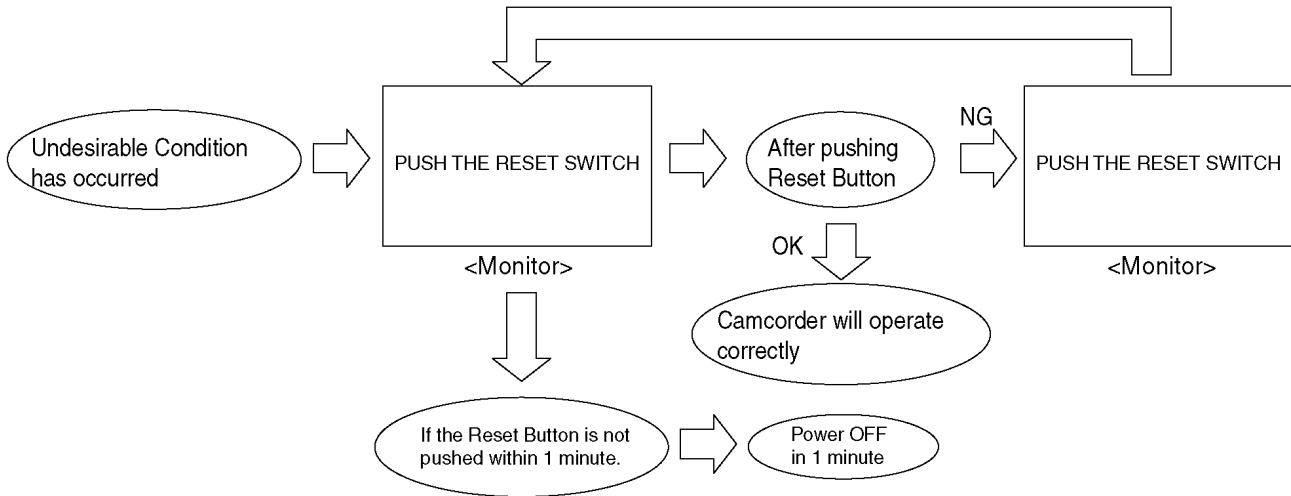

Fig. 1

Note:

When "PUSH THE RESET SWITCH" is displayed repeatedly, service is required. Check the Error Code which is listed in the Service Menu.

6.2. Service Menu

When abnormal detection contents are confirmed, do the following operation. Automatic diagnosis code will be displayed. (Service Menu)

To enter the Service Menu

Push the [DELETE], [JOYSTICK CONTROL LEFT] and [RECORDING START/STOP] simultaneously for 3 seconds (with no SD Card inserted).

Note:

If a Disc or SD Card is inserted, the above operation will not work.

This operation displays the following Service Menu items.

To select the Item

1. Set to Service Menu.
2. Press the [JOYSTICK CONTROL UP/DOWN] to select item [1], [2], [3], [4] or [5].
3. Press the [JOYSTICK CONTROL RIGHT] to display [YES/NO] screen.
4. Press the [JOYSTICK CONTROL UP/DOWN] to select [YES].
5. Press the [JOYSTICK CONTROL CENTER].

Note:

Only perform items 1, 2, 3, 4 and 5 in the Service Menu.

To exit the Service Menu

Unplug the AC Cord.

ARM (IC3201) version CAM (IC6001) version ROM correction version Drive firm version

0.5.0.5	0.1.1.3	0.0	RS18	1 / 2
1	NO			
2	NO			
3	NO			
4	NO			
5	NO			

<Service Menu 1/2>

- Item [1]: Factory setting (reset)
- Item [2]: Drive information
- Item [3]: Reset the total elapsed power on time
- Item [4]: LD temperature information
- Item [5]: Error/Lock Code/elapsed time

0 5 0 5	0 1 1 3	RS18	2 / 2
6	NO		
7	NO		
8	NO		

<Service Menu 2/2>

- Item [6]: AD 24ch data
 - Item [7]: Life Mode
 - Item [8]: Not used
- } ignore

DRIVE Information	
1. F/W Ver.	RS18
2. Serial	CA00012E
3. BER	00000000
4. ERR Code	00/00/00
5. LASER I/T	000/030
6. Function	Pass
7. Region	02

- ← 1. Drive firmware version
- ← 2. Drive Serial No.
- ← 3. Number of times of ECC Error revision
- ← 4. Error record
- ← 5. Laser current/LD temperature
- ← 6. Test result of factory
- ← 7. Region code

Note:
If 4. ERR Code is "0 4 / * * / * *", replace the DVD Drive Frame Unit.

<Item [2] screen>

RATE: **.*Mbps	← Recording bit rate
TEMP: ***/***	← LD temperature (current)/LD temperature (MAX)

<Item [4] screen>

[HourMeter]	
PWR: 0123h45m	← Total elapsed power on time
EE: 0000h00m	← ignore
[Error Code]	
CAM: 51 52 00	← The number before previous Previous number Latest number
TEMP: 0A	
DRV:	
000000000000000000000000000000	} ignore
000000000000000000000000000000	

<Item [5] screen>





Camera Error cord record in hexadecimal

Display	Explanation of cause
00	No error
51	Zoom Motor Lock
52	Focus Motor Lock

Fig. 2

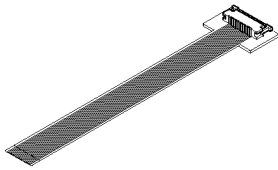
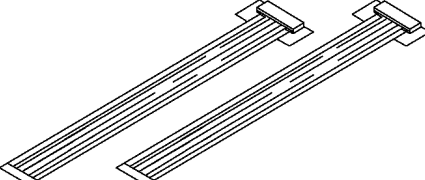
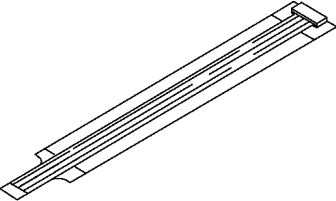
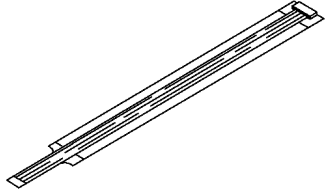
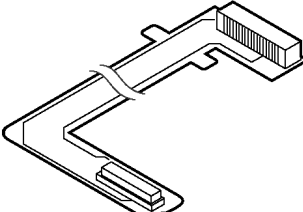
7 Service Fixture & Tools

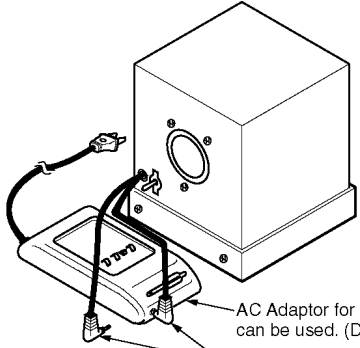
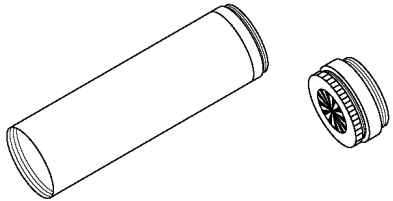
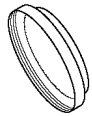
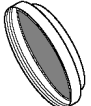
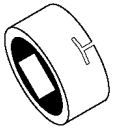
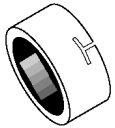
7.1. Service Fixture and Tools

<p>Extension Cable 20P LSUA0020</p> 	<p>Extension Cable 22P (2 pcs) VUVS0012</p> 	<p>Extension Cable 14P VFKW0124A</p> 		
<p>Extension Cable 12P VUVS0007</p> 	<p>Extension Cable 60P LSUA0059</p> 	<p>Plier for Non ZIF Connector LSVQ0028</p> 		
<p>Light Box and AC Adaptor VFK1164LBX1</p>  <p>AC Adaptor for C-Movie can be used. (DC +6V) Either plug can be used.</p> <p>(AC Adaptor is not supplied)</p>	<p>Infinity Lens (with Focus Chart) VFK1164TCM02</p> 	<p>27mm Ring VFK1164TAR27</p> 	<p>Color Conversion Filter (C14) VFK1164TFCT2</p> 	
		<p>White Chart VFK1164TFWC2</p> 	<p>Color Bar Chart VFK1164TFCB2</p> 	<p>Gray Scale Chart VFK1164TFGS2</p> 
<p>Grease LSUQ0050</p> 				

7.2. Service Position

Caution



Laser light striking the eye may cause your eyesight to be lost: For safety, be sure to remove any power supply (AC adaptor/charger, battery, etc.) from the DVD video camera/recorder before starting work.

<CSA requirement>

CAUTION: VISIBLE LASER RADIATION DO NOT STARE INTO THE BEAM OR VIEW DIRECTLY WITH OPTICAL INSTRUMENTS CLASS 2M

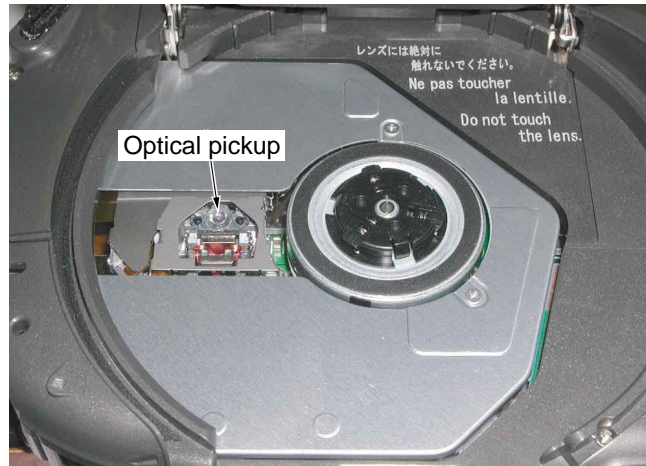

7.2.1. Extension Cables for Service Position

Using the following Extension Cables, place the unit as shown for check and service.

NO.	PART NUMBER	PART NAME	CONNECTION
①	LSUA0020	20Pin Extension Cable	FP3 on Main P.C.B. ~ Zoom Switch F.P.C. of Side L/Disk Unit
②	VUVS0012	22Pin Extension Cable	FP701 on Main P.C.B. ~ Lens F.P.C. on Lens Unit
③	VFKW0124A	14Pin Extension Cable	FP301 on Main P.C.B. ~ CCD F.P.C. on Lens Unit
④	VUVS0007	12Pin Extension Cable	FP2 on Main P.C.B. ~ Front F.P.C. of Front P.C.B.
⑤	VUVS0012	22Pin Extension Cable	FP1 on Main P.C.B. ~ Side R F.P.C. of Side R P.C.B.
⑥	LSUA0059	60Pin Extension Cable	B1 on Main P.C.B. ~ Connector of DVD Drive Frame Unit

Note :

1. The LCD open/close Switch is for changing between LCD Display or EVF Display. When turning on EVF Display, place some paper or tape, etc. on LCD open/close Switch so that this Switch stays ON.
2. To eject the DVD manually, slide the Lock lever on the Disc Cover Lock Unit for a short time.
3. Use a grounded ESD wrist strap while disassembling the Lens portion.
4. Connect the F.P.C.s to the connectors, verifying the direction of F.P.C.s as shown.
5. Use extreme care when plugging in or unplugging connectors.

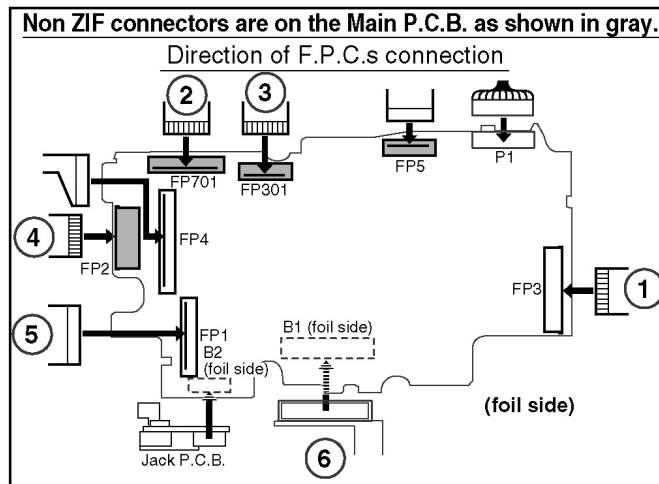
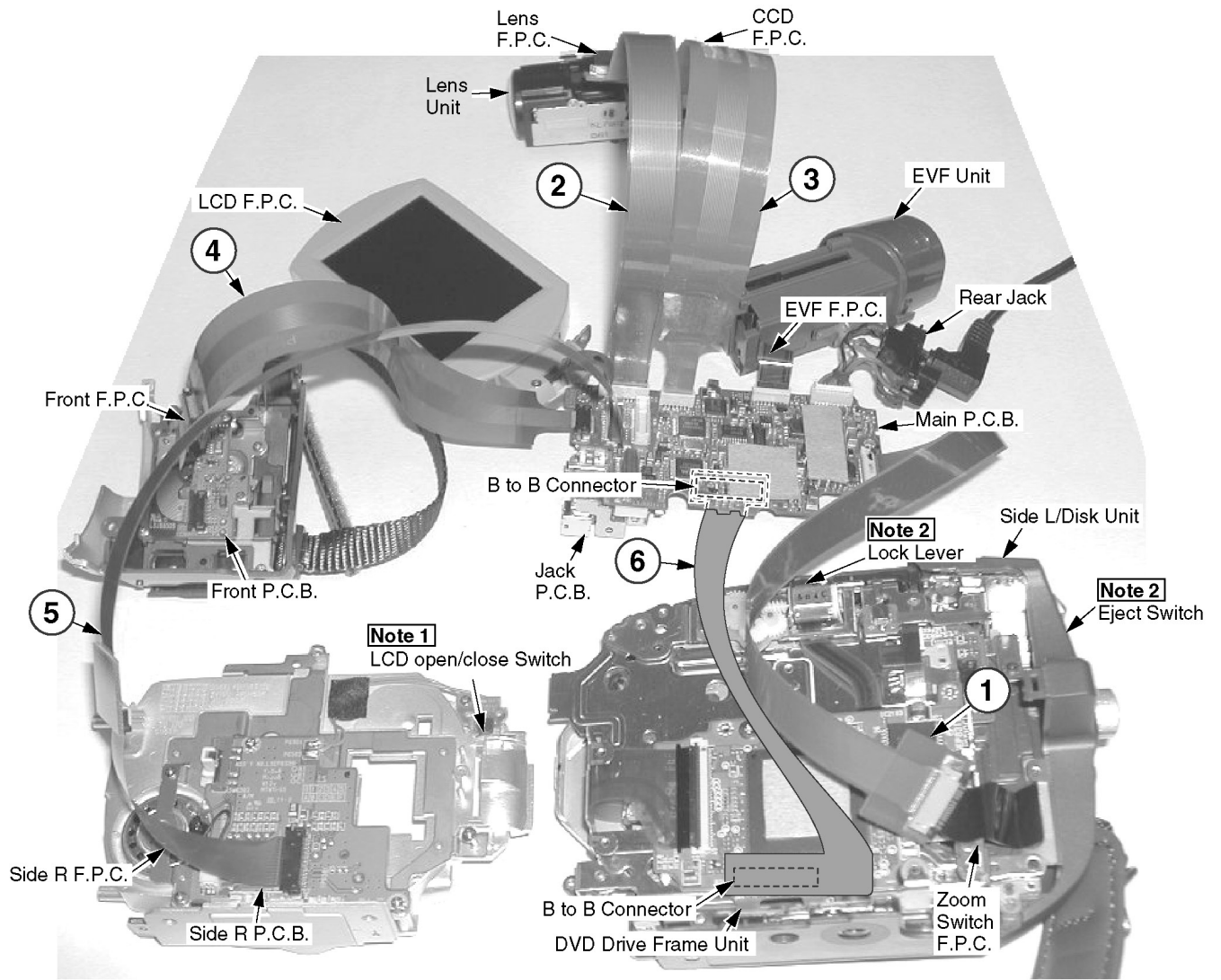

Fig. 3

7.3. Removal/Installation of F.P.C. From Non ZIF (Zero Insertion Force) Connector

Removal/Installation of F.P.C. from the Non ZIF (Zero Insertion Force) connector:

1. The Non ZIF connectors and the ZIF connectors are used on the unit. And there are 2 types (Type A, Type B) of Non ZIF connectors.
2. To remove the F.P.C. from the Non ZIF connector, use the Plier for Non ZIF Connector (LSVQ0028) to pull out the F.P.C. as shown. The same Plier for Non ZIF Connector (LSVQ0028) should also be used to install the F.P.C. to the Non ZIF Connector.

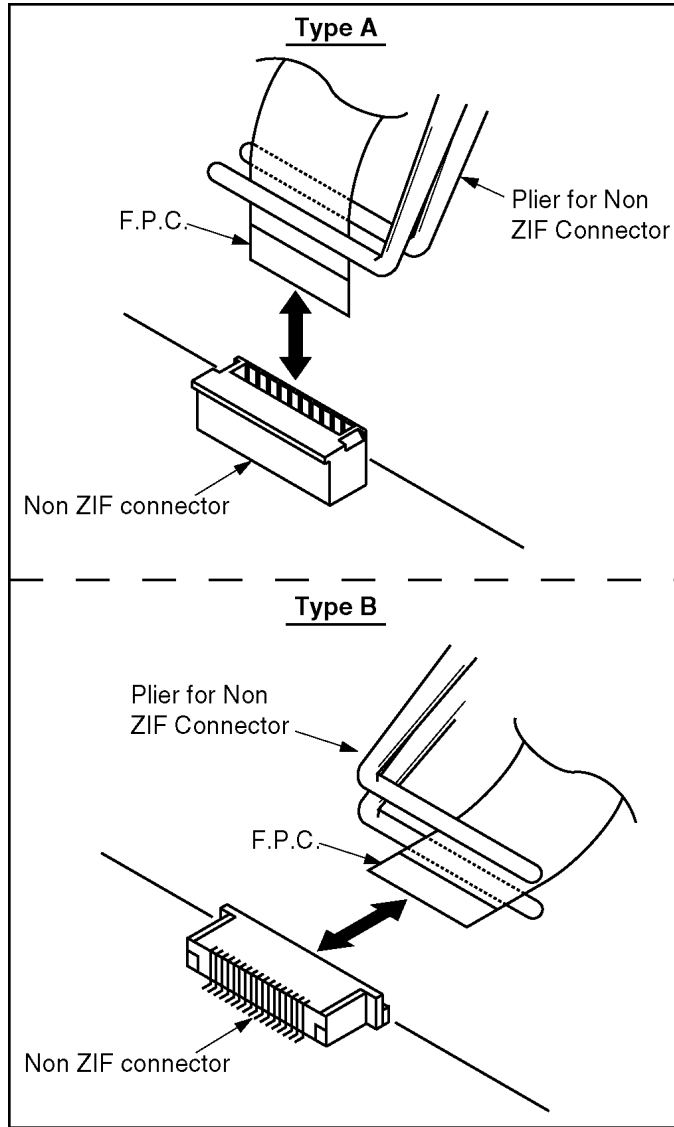
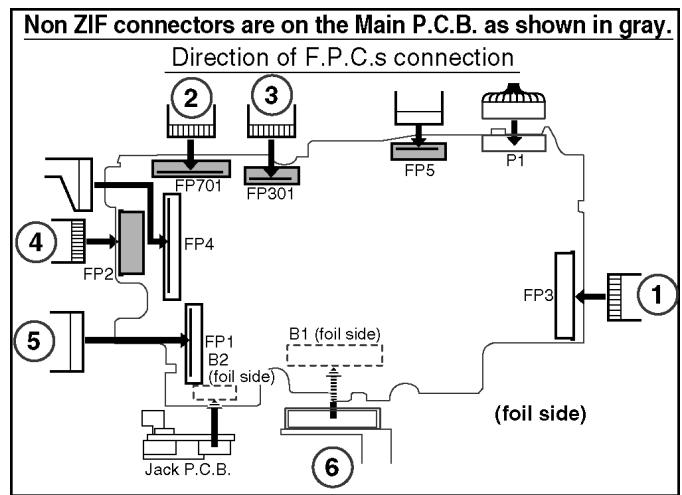

Fig. 4-1

3. Connect the F.P.C.s to the Non ZIF connectors, verifying the direction of F.P.C as shown.



7.4. Method for Ejecting the DVD Tray Manually

Caution



Laser light striking the eye may cause your eyesight to be lost: For safety, be sure to remove any power supply (AC adaptor/charger, battery, etc.) from the DVD video camera/recorder before starting work.

<CSA requirement>

CAUTION: VISIBLE LASER RADIATION DO NOT STARE INTO THE BEAM OR VIEW DIRECTLY WITH OPTICAL INSTRUMENTS CLASS 2M

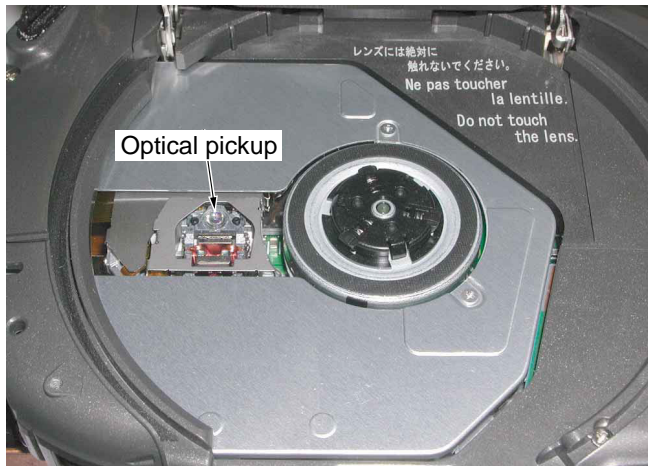

Perform the following procedures;

1. Remove the 6 Screws, and remove the Top Cover Unit. (Refer to "Disassembly and Assembly Instructions.")
2. Slide the Lock Lever to open the Disc Cover.
3. Remove the Disc.

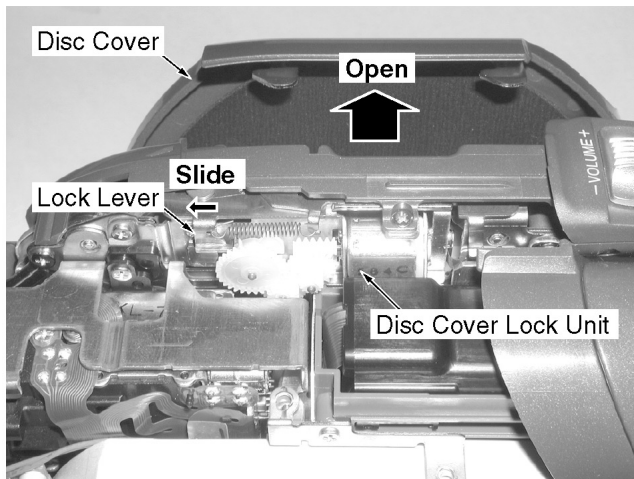

Fig. 5

7.5. EEPROM Data

CAUTION:

Be sure to save the EEPROM data using PC-EVR Adjustment Program before service and adjustment in order to make sure to avoid an accidental data loss, etc. using PC-EVR Adjustment Program by first.

EEPROM IC

C.B.A.	EEPROM IC Ref. No.
Main C.B.A.	IC6004

7.6. Special Note

All integrated circuits and many other semiconductor devices are electrostatically sensitive and therefore require the special handlings techniques described under the "ELECTROSTATICALLY SENSITIVE (ES) DEVICES" section of this service manual.

7.7. IC6001 REPLACEMENT NOTE

Two types of IC6001 (FLASH or MASK) are used on a running change basis, however MASK TYPE of IC6001 is supplied only as a replacement part.

Types of IC6001

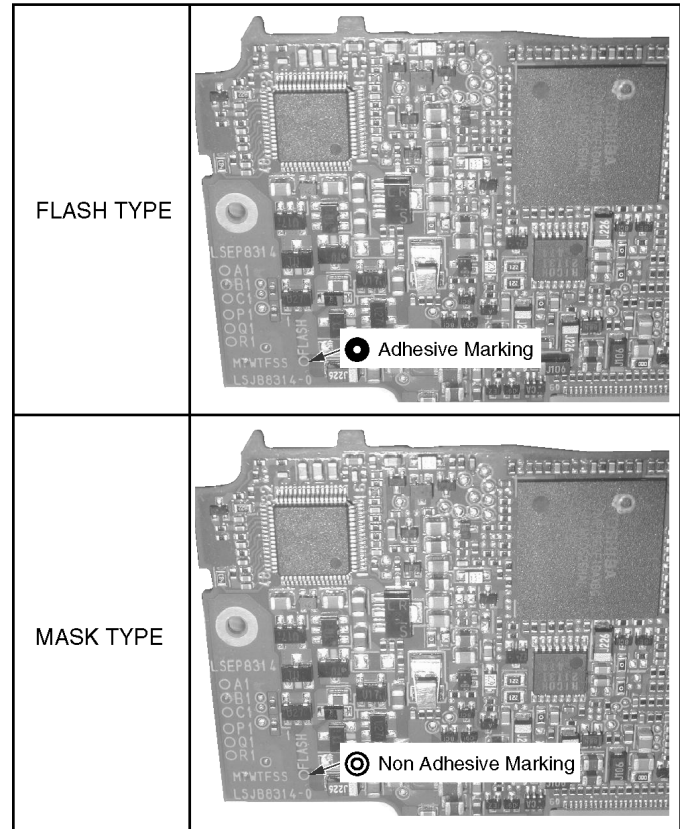

Perform the addition (R6010 and R6029) and also deletion (R6009 and R6030) of the following part simultaneously, when exchanging from the "FLASH TYPE" to the "MASK TYPE" of IC6001.

	FLASH TYPE	MASK TYPE	
Ref No.	Part No.	Part No.	Part Name
IC6001	-----	C2DBLK000122	IC
R6009	ERJ3GEY0R00V	-----	Resistor
R6010	-----	ERJ3GEY0R00V	Resistor
R6029	-----	ERJ3GEY0R00V	Resistor
R6030	ERJ3GEY0R00V	-----	Resistor

8 Disassembly and Assembly Instructions

8.1. Cabinet Section

8.1.1. DISASSEMBLY FLOWCHART

This flow chart indicates the disassembly steps of the cabinet parts and the P.C.Boards in order to gain access to item (s) to be serviced. When reassembling, perform the step (s) in the reverse order. Bend, route and dress the wires as they were originally.

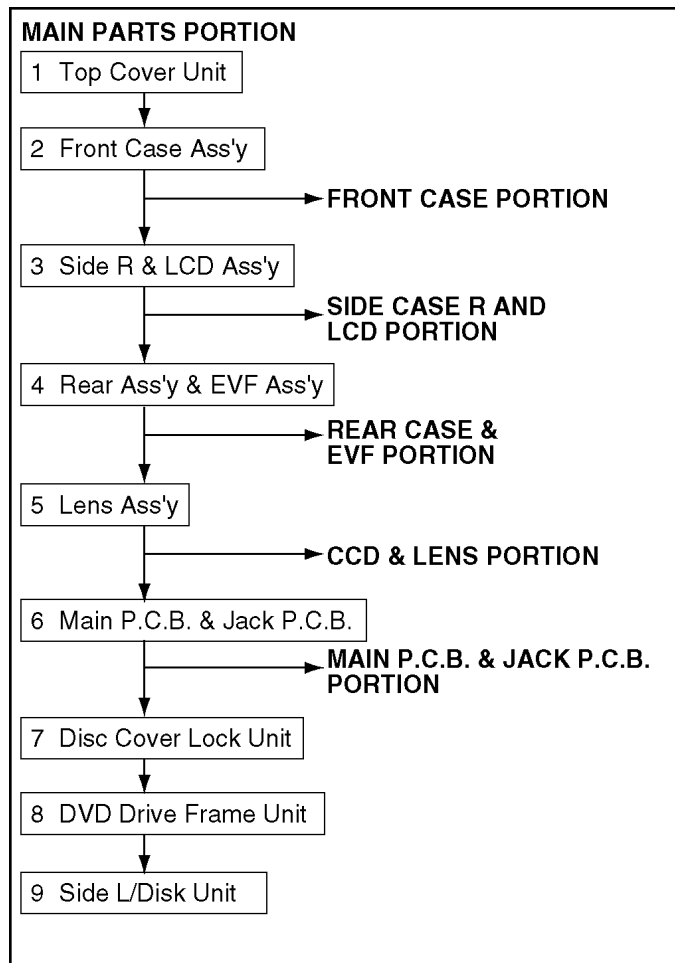

Note :

1. When removing the cabinet, work with care so as not to break the Locking Tabs.
2. Place a cloth or some other soft material under the P.C. Boards or Unit to prevent damage.
3. When reinstalling, ensure that the connectors are connected and electrical components have not been damaged.
4. Do not supply power to the unit during disassembly and reassembly.



Caution
Laser light striking the eye may cause your eyesight to be lost: For safety, be sure to remove any power supply (AC adaptor/charger, battery, etc.) from the DVD video camera/recorder before starting work.

<CSA requirement>

CAUTION: VISIBLE LASER RADIATION DO NOT STARE INTO THE BEAM OR VIEW DIRECTLY WITH OPTICAL INSTRUMENTS CLASS 2M

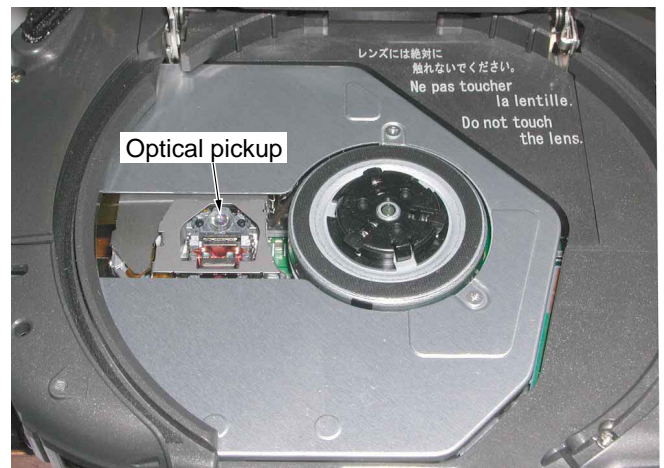

8.1.2. Disassembly Method

MAIN PARTS PORTION

STEP No.	Ref. No.	PART	Section No.	REMOVE	NOTE
1	④	Top Cover Unit	①	(519), 5(533)	1
2	-	Front Case Ass'y	①	3(519), 2(533), FP2, Hand Strap	2
3	-	Side R & LCD Ass'y	①	3(519), 3(533), FP1, FP4	3
4	-	Rear Case & EVF Ass'y	①	6(519), FP5, P1	4
5	-	Lens Ass'y	①	2(519), FP301, FP701	5
6	-	Main P.C.B. & Jack P.C.B.	①	(419), 5(519), FP3, B1	6
7	③	Disc Cover Lock Unit	①	(419), (533), (544), Connector	7
8	②	DVD Drive Frame Unit	①	2(519)	8
9	①	Side L/Disk Unit	①	2(519), (533), (7)	-

↑ ↑ ↑ ↑ ↑ ↑
 A B C D E F

How to read chart shown above:

- A: Order of Procedure steps.
When reassembling, perform steps(s) in reverse order.
- B: Ref No.
- C: Part to be removed or installed.
- D: Section No.
- E: Identification of part to be removed, unhooked, unlocked, released, unplugged, unclamped, or unsoldered.
3(404)= 3 Screws (404), 2(L-1) = 2 Looking Tabs (L-1)
- F: Refer to "Notes in chart."

1 MAIN PARTS SECTION

Note:

1. Parts with no Ref. No. in "EXPLODED VIEW" are not supplied. And some Ref. No. will be skipped. Be sure to make your orders of replacement parts according to the parts list.
2. The parts indicated by the dotted line  are for Ass'y only and are not supplied.
3. Disregard Ref. No. suffixes when ordering parts. They are used to describe parts in "Disassembly and Assembly Instructions" section.

IMPORTANT SAFTY NOTICE:

COMPONENTS IDENTIFIED BY THE SIGN  HAVE SPECIAL CHARACTERISTICS IMPORTANT FOR SAFETY. WHEN REPLACING ANY OF THESE COMPONENTS, USE ONLY THE SPECIFIED PARTS.

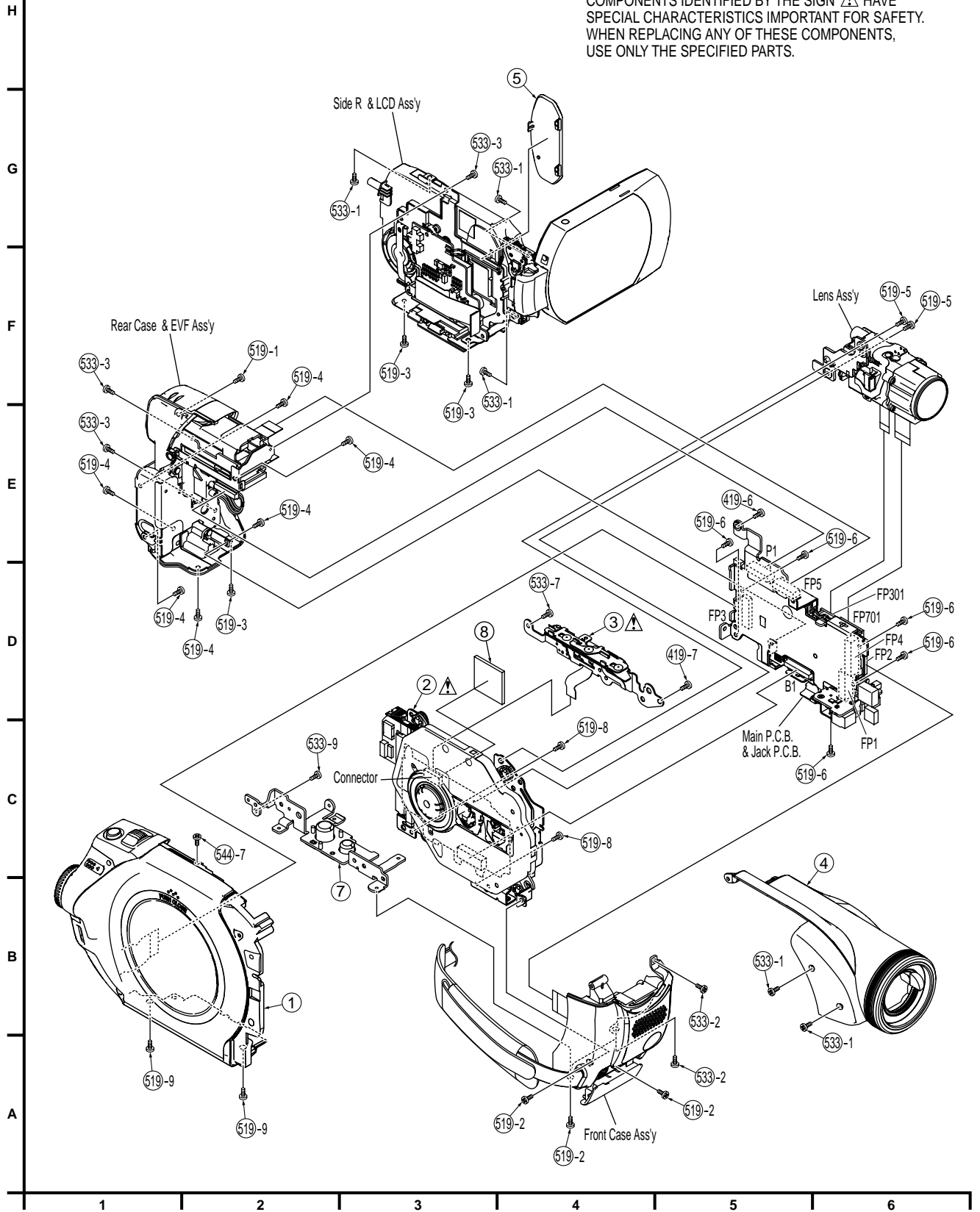

FRONT CASE, MAIN P.C.B. & JACK P.C.B.

STEP No.	Ref. No.	PART	Section No.	REMOVE	NOTE
1	Ⓔ30	Jack P.C.B	2	(519), B2	9
2	Ⓔ10	Main P.C.B	2	-----	-

↑ ↑ ↑ ↑ ↑ ↑
 A B C D E F

STEP No.	Ref. No.	PART	Section No.	REMOVE	NOTE
1	Ⓔ20	Front P.C.B.	2	5(533)	10
2	Ⓔ2	(For models with Light) LED Light Lens	2	-----	10
3	Ⓔ1	Front Case Unit	2	-----	10

↑ ↑ ↑ ↑ ↑ ↑
 A B C D E F

How to read chart shown above:

- A: Order of Procedure steps.
When reassembling, perform steps(s) in reverse order.
- B: Ref No.
- C: Part to be removed or installed.
- D: Section No.
- E: Identification of part to be removed, unhooked, unlocked, released, unplugged, unclamped, or unsoldered.
- F: Refer to "Notes in chart."

② FRONT CASE, MAIN P.C.B. AND JACK P.C.B. SECTION

Note:

1. Parts with no Ref. No. in "EXPLODED VIEW" are not supplied. And some Ref. No. will be skipped. Be sure to make your orders of replacement parts according to the parts list.
2. The parts indicated by the dotted line  are for Ass'y only and are not supplied.
3. Disregard Ref. No. suffixes when ordering parts. They are used to describe parts in "Disassembly and Assembly Instructions" section.

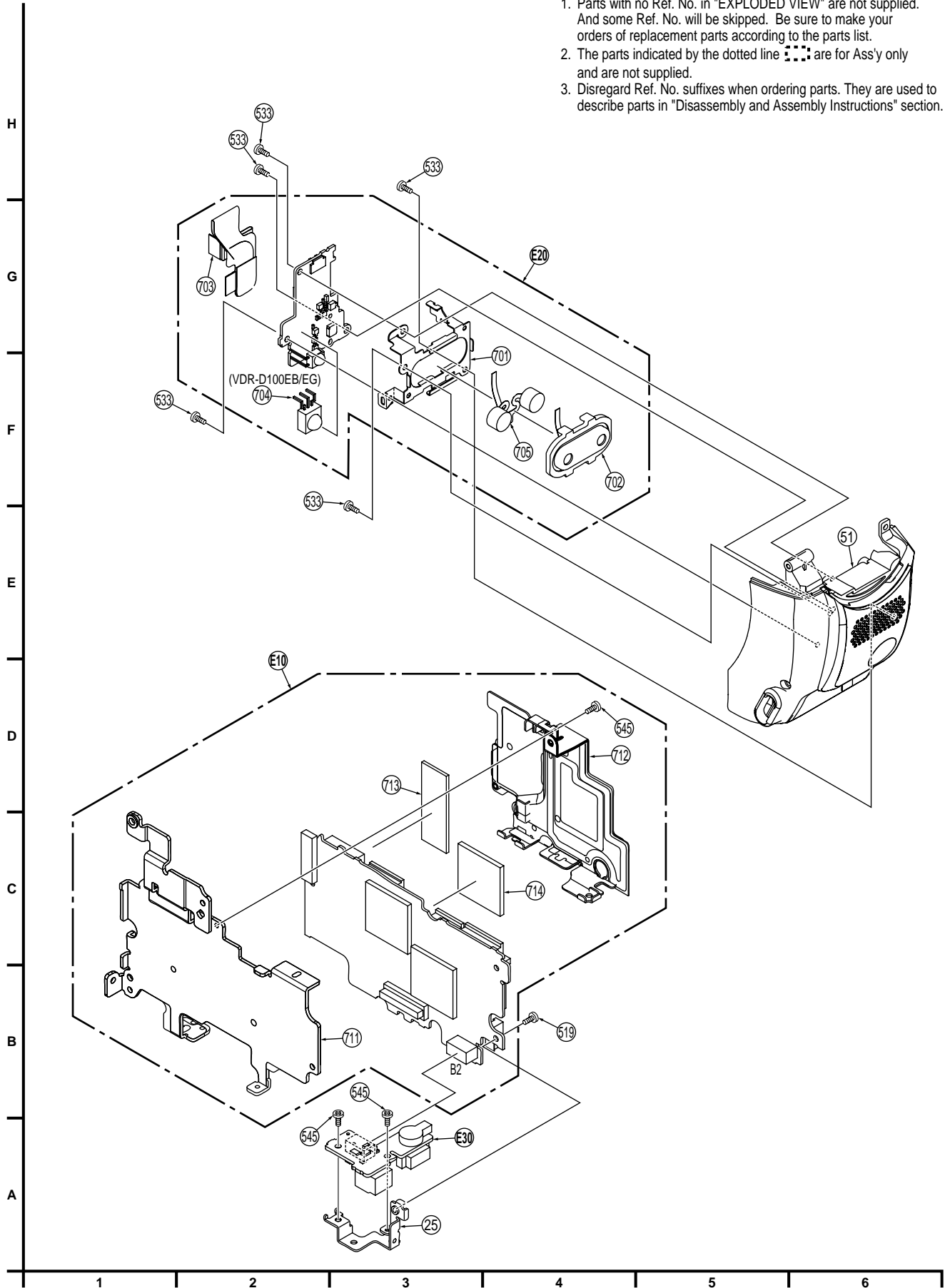

SIDE CASE R PORTION

STEP No.	Ref. No.	PART	Section No.	REMOVE	NOTE
1	-	Side R/SD Ass'y	③	(408), (457)	11
2	④⑤	Speaker	③	2(533), (46)	11
3	⑥⑩	Side R P.C.B.	③	2(533), Unsolder	11
4	⑥⑪	Open Switch P.C.B.	③	(533), (48)	11

↑ A ↑ B ↑ C ↑ D ↑ E ↑ F

How to read chart shown above:

- A: Order of Procedure steps.
 When reassembling, perform steps(s) in reverse order.
- B: Ref No.
- C: Part to be removed or installed.
- D: Section No.
- E: Identification of part to be removed, unhooked, unlocked, released, unplugged, unclamped, or unsoldered.
- F: Refer to "Notes in chart."

LCD PORTION

STEP No.	Ref. No.	PART	Section No.	REMOVE	NOTE
1	③③	LCD Case A Unit	③	2(519), 2(546), 7(L-1)	-
2	③②	LCD Shaft Case Unit	③	FP8101	-
3	④⑩	LCD Backlight P.C.B.	③	(533), (L-2), FP8102	12
4	③④	LCD Case B	③	4(L-3)	12
5	- ③⑤	LCD Panel Ass'y ----- LCD Shield Plate Unit	③	3(L-4)	12

↑ A ↑ B ↑ C ↑ D ↑ E ↑ F

STEP No.	Ref. No.	PART	Section No.	REMOVE	NOTE
1	④②	LCD Panel	③	-----	13
2	③⑨	Reflect Sheet	③	(L-5)	13
3	③⑦	Lead Light Panel	③	-----	13
4	③⑧	Diffusion Sheet	③	-----	13
5	④⑩	BEF Sheet	③	-----	13
6	④①	BEF Sheet A	③	-----	13
7	③⑥	LCD Panel Holder Unit	③	-----	13

↑ A ↑ B ↑ C ↑ D ↑ E ↑ F

How to read chart shown above:

- A: Order of Procedure steps.
 When reassembling, perform steps(s) in reverse order.
- B: Ref No.
- C: Part to be removed or installed.
- D: Section No.
- E: Identification of part to be removed, unhooked, unlocked, released, unplugged, unclamped, or unsoldered.
- F: Refer to "Notes in chart."

③ SIDE CASE R AND LCD SECTION

Note:

1. Parts with no Ref. No. in "EXPLODED VIEW" are not supplied. And some Ref. No. will be skipped. Be sure to make your orders of replacement parts according to the parts list.
2. The parts indicated by the dotted line  are for Ass'y only and are not supplied.
3. Disregard Ref. No. suffixes when ordering parts. They are used to describe parts in "Disassembly and Assembly Instructions" section.

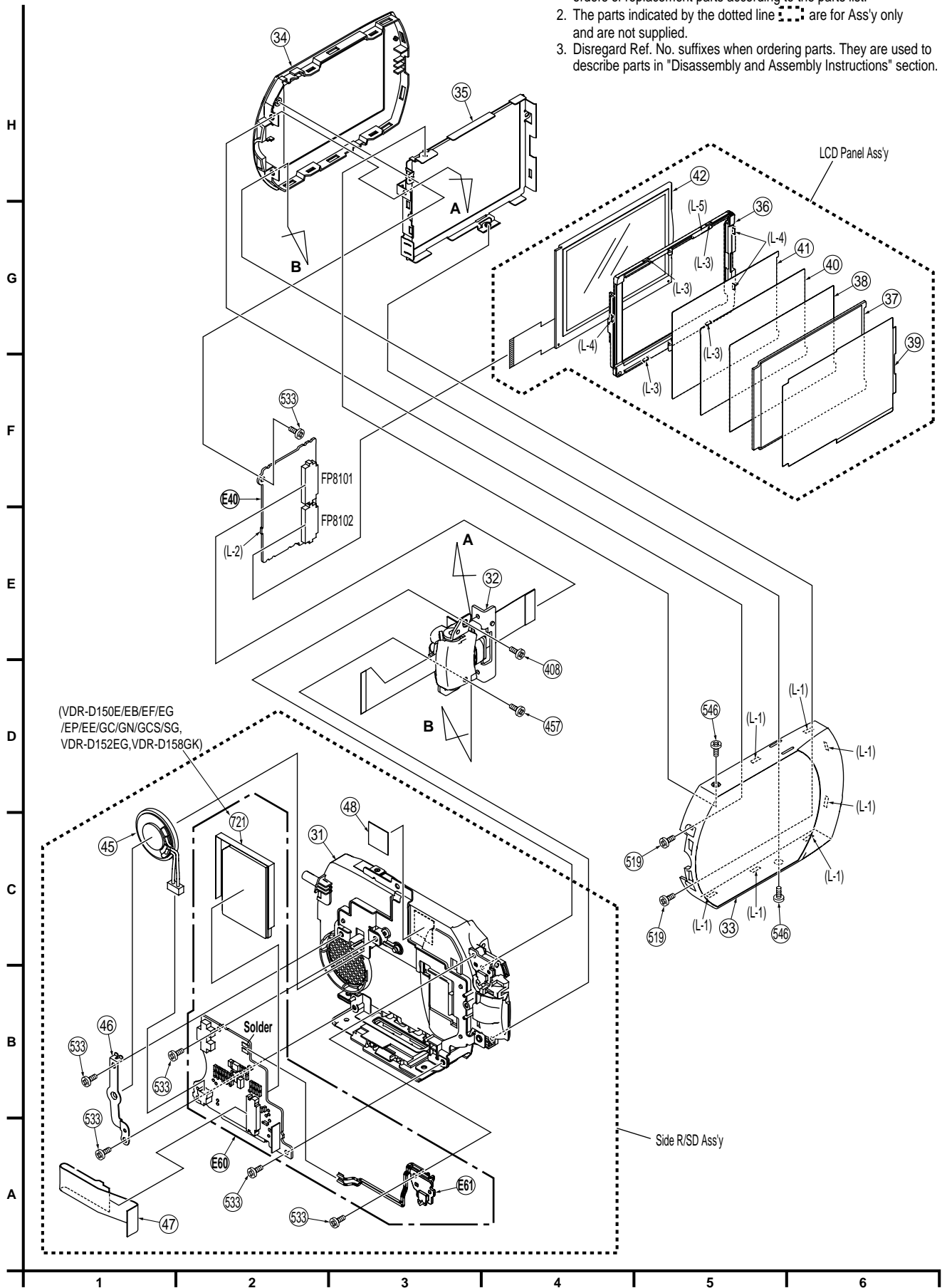

CCD & LENS PORTION

STEP No.	Ref. No.	PART	Section No.	REMOVE	NOTE
1	Ⓔ50	CCD P.C.B.	4	2(536)	14
2	Ⓔ64	Filter Rubber	4	-----	14
3	Ⓔ63	Optical Filter	4	-----	14

↑ A ↑ B ↑ C ↑ D ↑ E ↑ F

STEP No.	Ref. No.	PART	Section No.	REMOVE	NOTE
1	Ⓔ26	Lens Holder	4	2(533)	-
2	Ⓔ65	Zoom Motor Unit	4	2(538), Unsolder	15
3	Ⓔ66	Focus Motor Unit	4	3(538), Unsolder	15

↑ A ↑ B ↑ C ↑ D ↑ E ↑ F

How to read chart shown above:

A: Order of Procedure steps.

When reassembling, perform steps(s) in reverse order.

B: Ref No.

C: Part to be removed or installed.

D: Section No.

E: Identification of part to be removed, unhooked, unlocked, released, unplugged, unclamped, or unsoldered.

F: Refer to "Notes in chart."



4 CCD AND LENS SECTION

Note:

1. Parts with no Ref. No. in "EXPLODED VIEW" are not supplied. And some Ref. No. will be skipped. Be sure to make your orders of replacement parts according to the parts list.
2. The parts indicated by the dotted line  are for Ass'y only and are not supplied.
3. Disregard Ref. No. suffixes when ordering parts. They are used to describe parts in "Disassembly and Assembly Instructions" section.

LUBRICATION POINTS

When the marked parts are replaced, apply the recommended lubricants or adhesive for better maintenance of the unit.

Mark	Kind of Lubricant	Availability	Part Number
 	Grease	Available from Factory	LSUQ0050

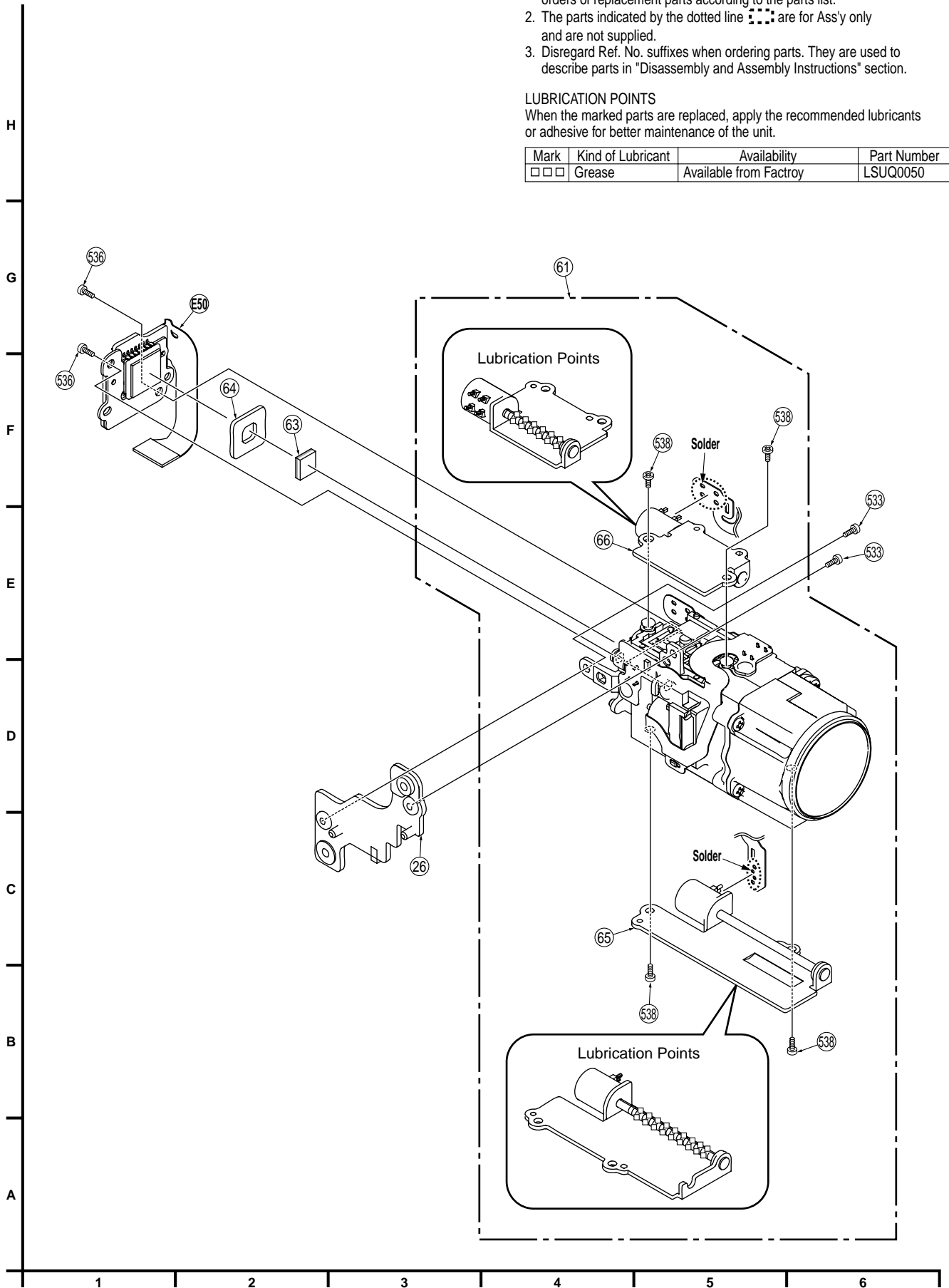

REAR CASE & EVF PORTION

STEP No.	Ref. No.	PART	Section No.	REMOVE	NOTE
1	⑳	EVF Unit	⑤	2(433), (L-1)	16
2	㉑	Rear Case Unit	⑤	-----	16

↑ A ↑ B ↑ C ↑ D ↑ E ↑ F

STEP No.	Ref. No.	PART	Section No.	REMOVE	NOTE
1	⑬ ⑮	EVF Base Frame ----- EVF Earth Plate	⑤	FP901	17
2	⑰	EVF F.P.C.	⑤	-----	17

↑ A ↑ B ↑ C ↑ D ↑ E ↑ F

STEP No.	Ref. No.	PART	Section No.	REMOVE	NOTE
1	⑱	Eye Cap	⑤	2(533), (L-2)	18
2	㉓	EVF Lens Unit	⑤	-----	18
3	㉒	Eye Sight Lever	⑤	-----	18

↑ A ↑ B ↑ C ↑ D ↑ E ↑ F

How to read chart shown above:

- A: Order of Procedure steps.
When reassembling, perform steps(s) in reverse order.
- B: Ref No.
- C: Part to be removed or installed.
- D: Section No.
- E: Identification of part to be removed, unhooked, unlocked, released, unplugged, unclamped, or unsoldered.
- F: Refer to "Notes in chart."

5 REAR CASE AND EVF SECTION

Note:

1. Parts with no Ref. No. in "EXPLODED VIEW" are not supplied. And some Ref. No. will be skipped. Be sure to make your orders of replacement parts according to the parts list.
2. The parts indicated by the dotted line  are for Ass'y only and are not supplied.
3. Disregard Ref. No. suffixes when ordering parts. They are used to describe parts in "Disassembly and Assembly Instructions" section.

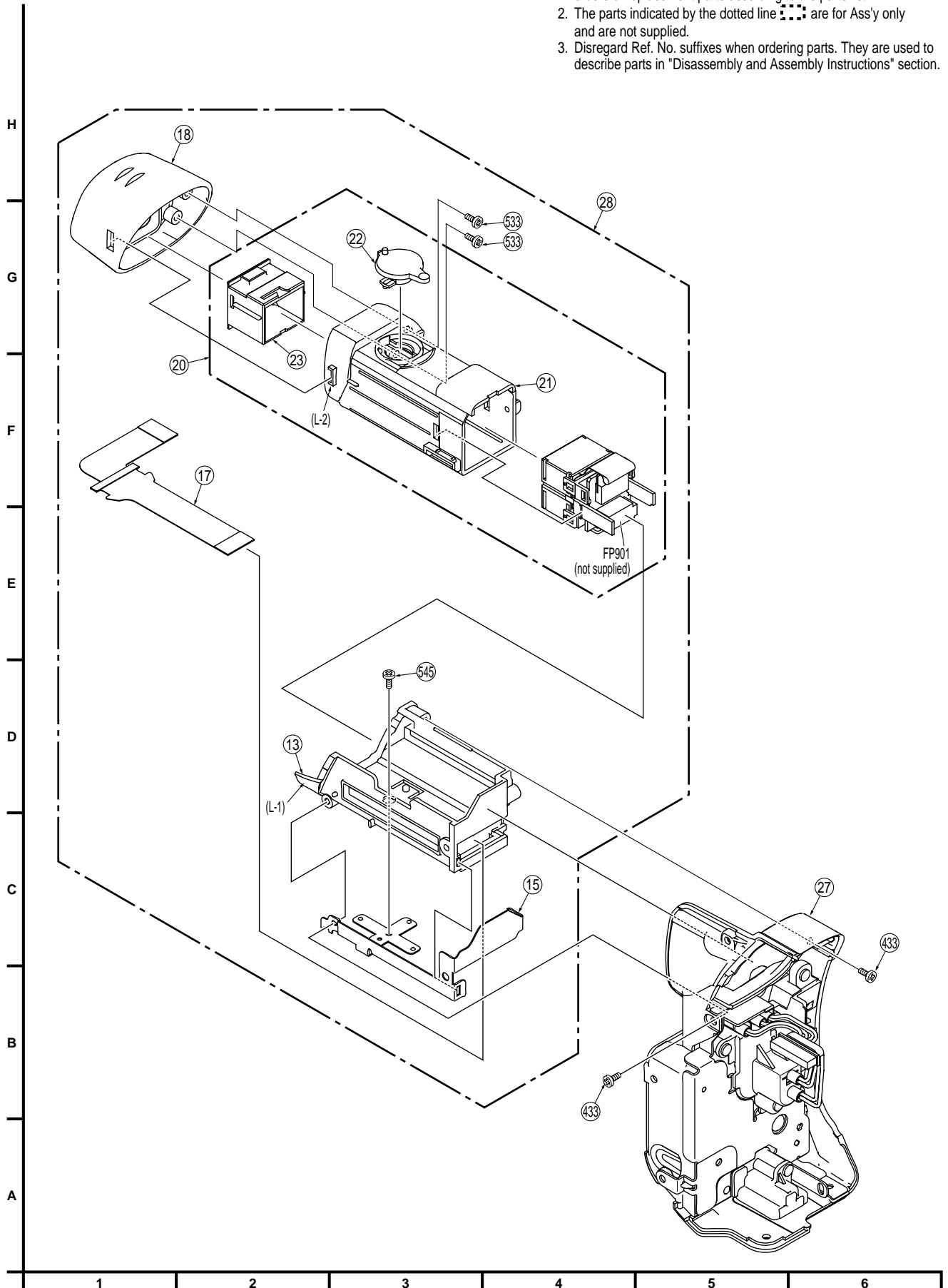

Notes in chart

1. Removal of Top Cover Unit

- 1) Open the LCD and remove the 5 Screws (533).
- 2) Slide the EVF to extend it, then remove Screw (519).
- 3) Pull and carefully slide the Top Cover Unit.

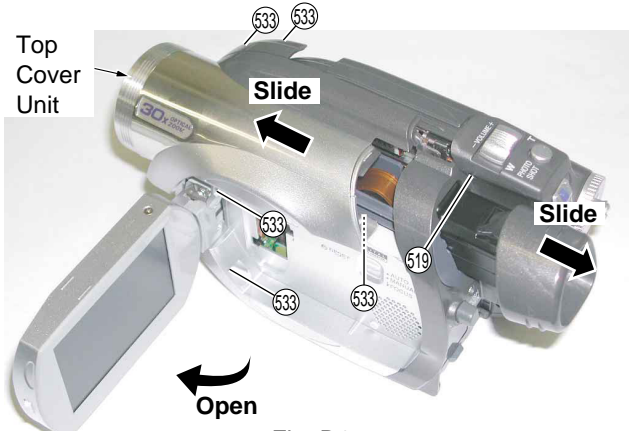
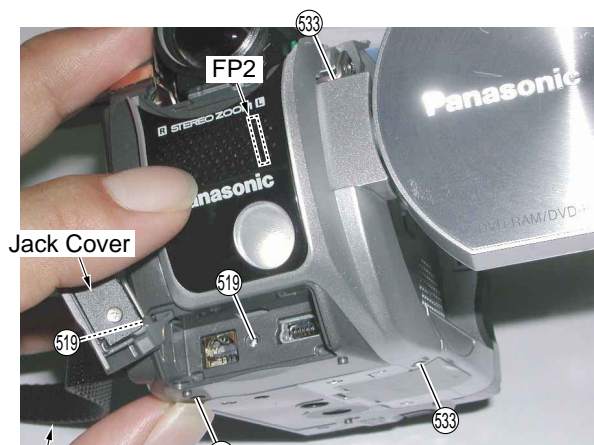

Fig. D1

2. Removal of Front Case Ass'y

- 1) Open the Jack Cover, then remove Screw (519).
- 2) Remove the 4 Screws (519, 533).
- 3) Disconnect the Front F.P.C. from Connector FP2.
- 4) Remove the Front Case Ass'y while releasing the Hand Strap.



<Front View>

Fig. D2

3. Installation of Side R & LCD Ass'y

- 1) Connect the LCD F.P.C. and Side R F.P.C. to the Connectors FP4 and FP1 so as not to damage the F.P.C.s.
- 2) Secure Rear Portion, and tighten 6 Screws (519, 533) Side R & LCD Ass'y

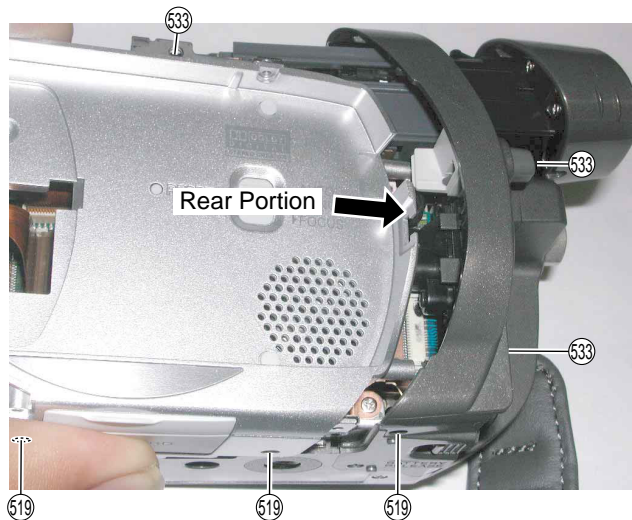
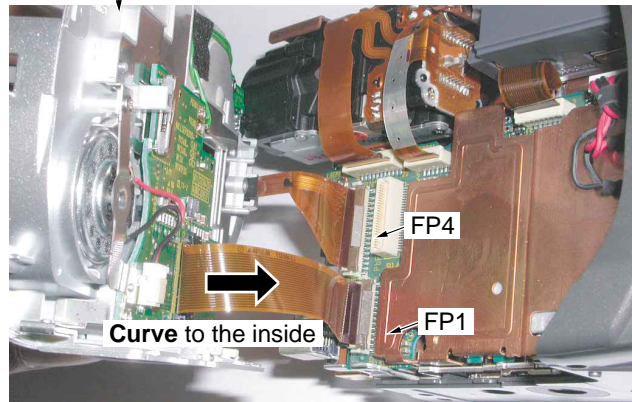

Fig. D3

4. Removal of Rear Case & EVF Ass'y

- 1) Disconnect the EVF F.P.C. and the Connector Cable from Connector FP5 and P1.
- 2) Remove the 6 Screws (519).

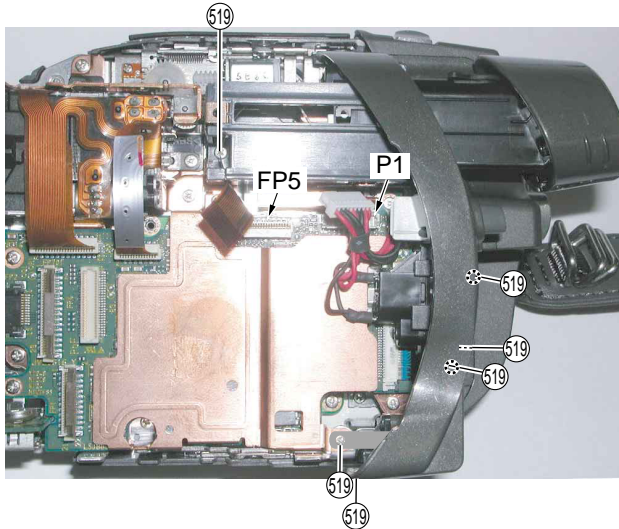

Fig. D4

5. Installation of Lens Ass'y

Take care not to damage the motor leads.

- 1) Install the Lens Ass'y with the 2 holes and 2 Screws (519).
- 2) Connect the F.P.C.s to Connector FP301, FP701.

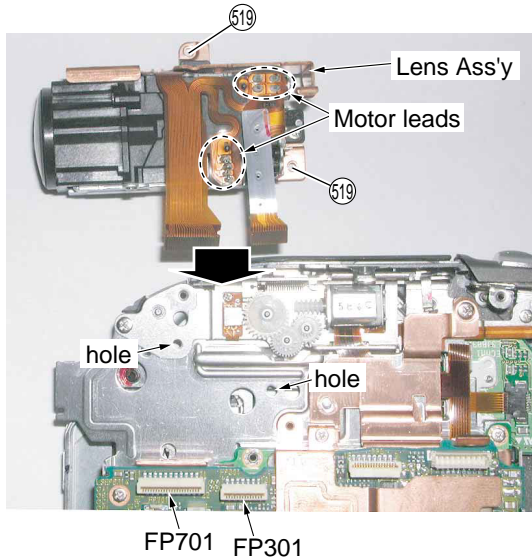

Fig. D5

6. Removal of Main P.C.B. and Jack P.C.B.

- 1) Remove the 6 Screws (419, 519).
- 2) Disconnect the Zoom Switch F.P.C. from Connector FP3.
- 3) Remove the Main P.C.B. and Jack P.C.B. to disconnect Connector B1 (B to B Connector).

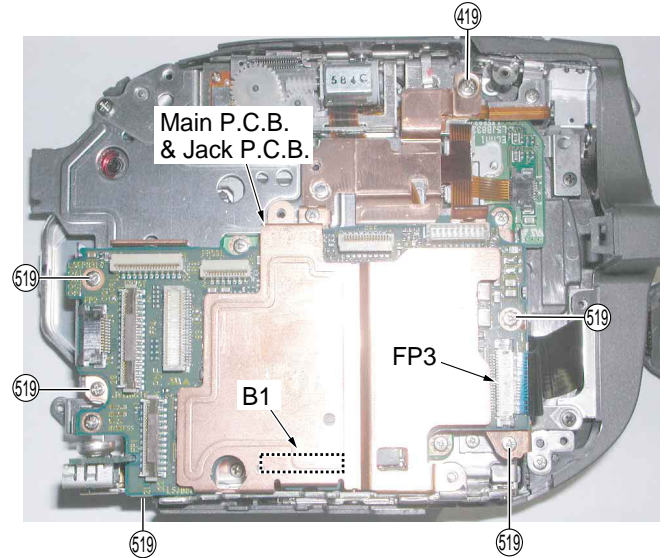

Fig. D6

7. Removal of Disc Cover Lock Unit

- 1) Remove the 3 Screws (419, 533, 544)
- 2) Slide the Lock Lever to open the Disc Cover.
- 3) Disconnect the F.P.C. from Connector on the DVD Drive Frame Unit.
- 4) Remove the Disc Cover Lock Unit. Take care not to damage the 2 Switches.

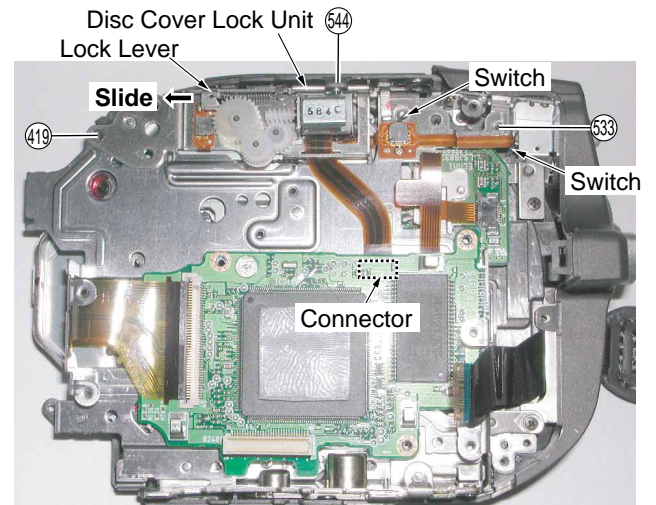

Fig. D7

8. DVD Drive Frame Unit Caution

Caution



Laser light striking the eye may cause your eyesight to be lost: For safety, be sure to remove any power supply (AC adaptor/charger, battery, etc.) from the DVD video camera/recorder before starting work.

<CSA requirement>

CAUTION: VISIBLE LASER RADIATION DO NOT STARE INTO THE BEAM OR VIEW DIRECTLY WITH OPTICAL INSTRUMENTS CLASS 2M

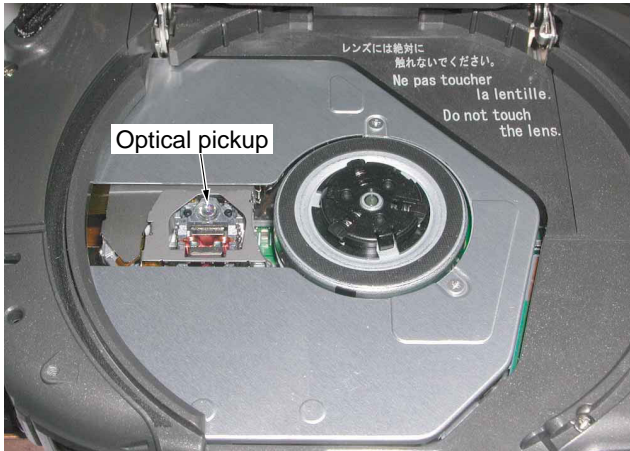

Fig. D8-1

Installation of DVD Drive Frame Unit

- 1) Position the DVD Drive Frame Unit correctly so that the Zoom Switch F.P.C. is not pinned beneath it.
- 2) Tighten the 2 Screws (519).

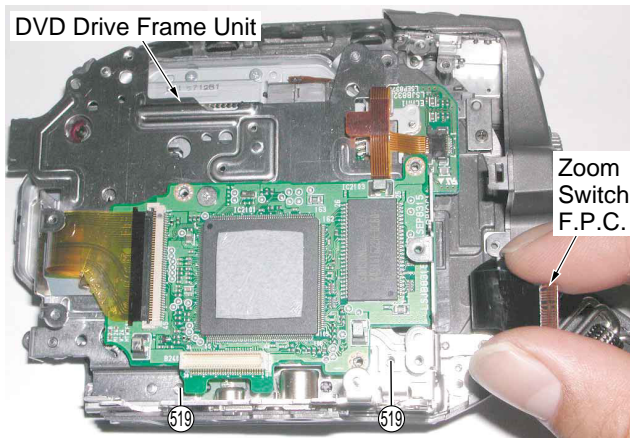

Fig. D8-2

9. Installation of Jack P.C.B.

- 1) Connect the Connector B2 (B to B Connector).
- 2) Tighten Screw (519).

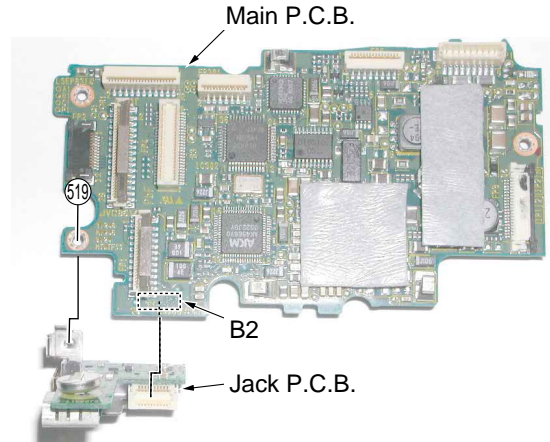

Fig. D9

10. Installation of Front P.C.B.

- 1) Install the LED Light Lens (For models with Light) into the Front Case Unit.
- 2) Install the Front P.C.B. with 2 bosses of the LED Light Lens and the 5 Screws (533).

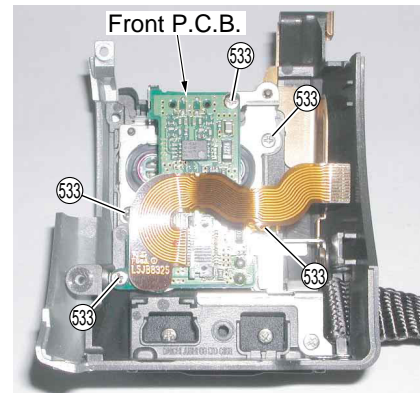
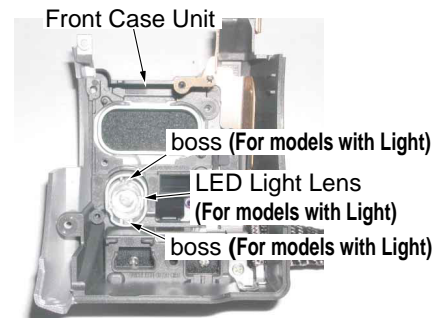

Fig. D10

11. Removal of Side R/SD Ass'y

- 1) Close the LCD (Ass'y).
- 2) Remove the 2 Screws (408, 457) as shown below.

Installation of Side R/SD Ass'y

- 1) Pass the LCD F.P.C. into the slot.
- 2) Install the LCD (Ass'y) into the Side R/SD Ass'y so as not to damage the LCD open/close SW.

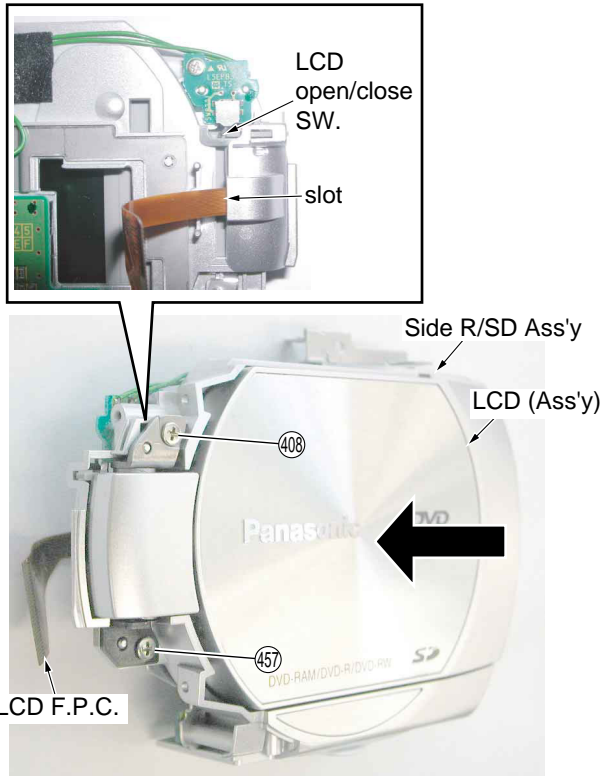

Fig. D11-1

Removal of Speaker, Side R P.C.B. and Open Switch P.C.B.

- 1) Remove the 2 Screws (533) and remove the Speaker Spring Plate.
- 2) Disconnect Connector P6301, then remove the Speaker.
- 3) Remove the 2 Screws (533), then unsolder the connector leads to remove the Side R P.C.B.
- 4) Remove Screw (533) and sheet, then remove the Open Switch P.C.B.

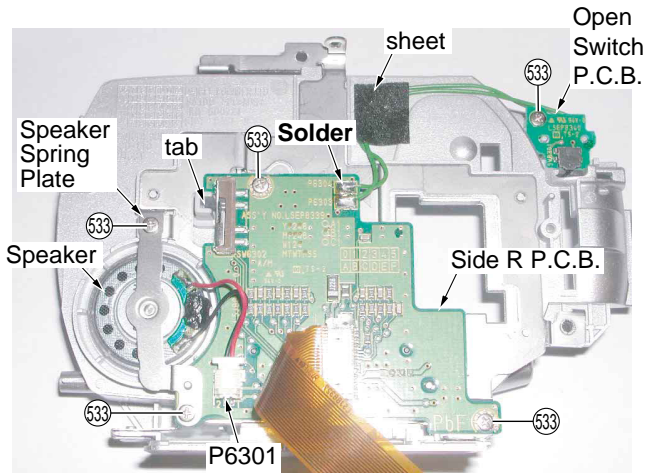

Fig. D11-2

12. Installation of LCD Backlight P.C.B., LCD Panel Ass'y, LCD Shield Case Unit and LCD Case B

Be extremely careful of LEDs when handling the LCD Backlight P.C.B.

Install in order shown below.

- 1) Install the LCD Shield Case Unit into the LCD Case B with 2 bosses.
- 2) Install the LCD Panel Ass'y onto the LCD Case B with the 7 Locking Tabs (L-3), (L-4) while carefully bending the LCD F.P.C. at its base so as not to damage it.
- 3) Install the LCD Backlight P.C.B. onto the LCD Panel Ass'y with the Locking Tab (L-2).
- 4) Tighten Screw (533) while keeping the LCD Backlight P.C.B. pressed toward the right. Then, connect the F.P.C. to Connector FP8102.

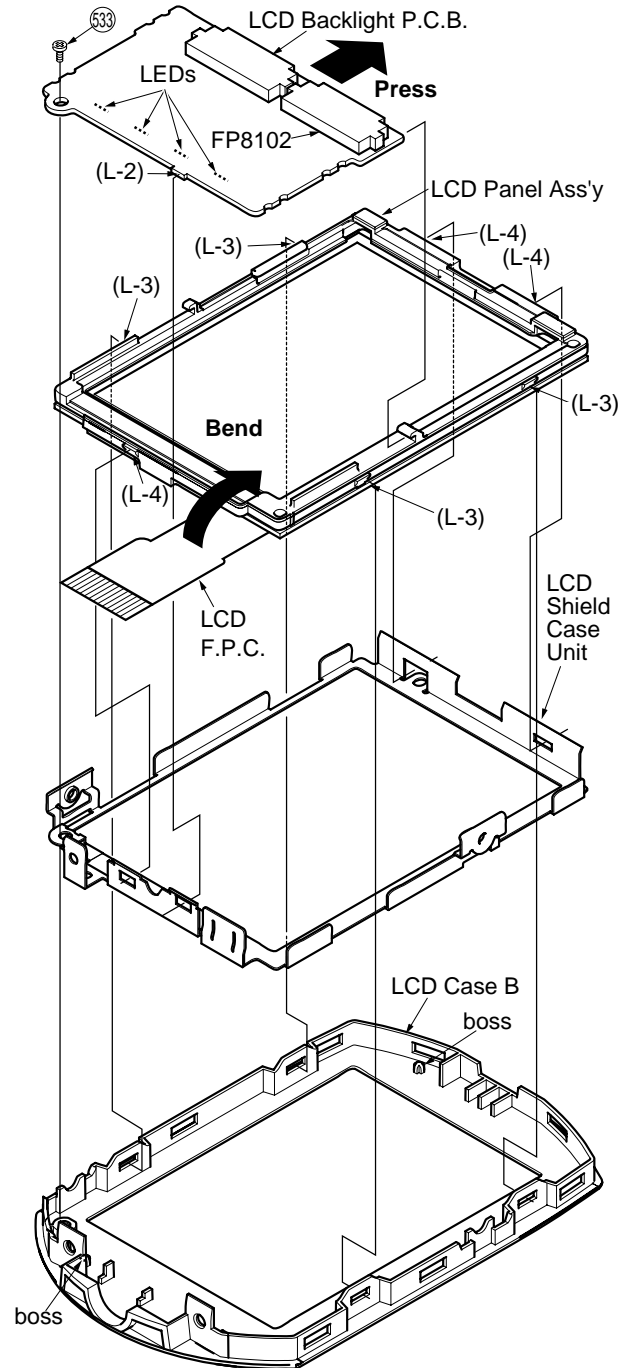

Fig. D12

13. Installation of LCD Panel, Reflect Sheet, Lead Light Panel, Diffusion Sheet, BEF Sheet, BEF Sheet A and Panel Holder Unit

a. When replacing the LCD Panel, the Diffusion Sheet, the BEF Sheet and the BEF Sheet A, be sure to remove the Protection Sheets.

To distinguish Sheets from their Protection Sheets:

- A blue Protection Sheet is affixed to both faces of the Diffusion Sheet.
- A yellow Protection Sheet is affixed to both faces of the BEF Sheet.
- A green Protection Sheet is affixed to both faces of the BEF Sheet A.

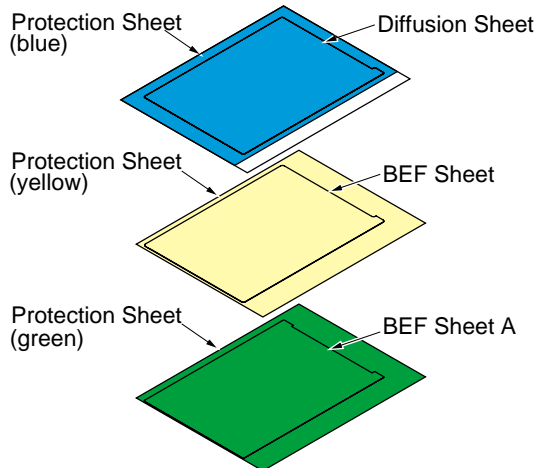

b. Use extreme care when handling the LCD Panel, the Reflect Sheet, the Lead Light Panel, the Diffusion Sheet, the BEF Sheet and the BEF Sheet A to avoid damage, dust, and spots (especially fingerprints, etc.)

Install in order shown below.

- 1) Install in order, the BEF Sheet A, BEF Sheet and Diffusion Sheet while inserting the corners of each sheet into the slots of the Panel Holder Unit.
- 2) Install the Lead Light Panel while inserting the corners into the slots of the Panel Holder Unit.
- 3) Place the Reflect Sheet so it is aligned with the edge of the Panel Holder Unit, then install it using the adhesive tape portions of the Reflect Sheet.

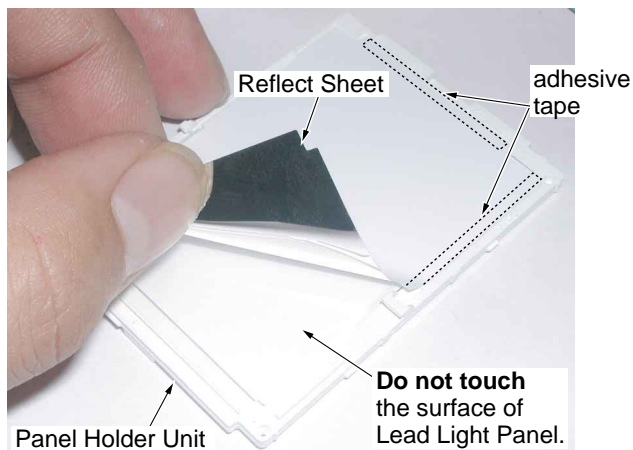

Fig. D13-1

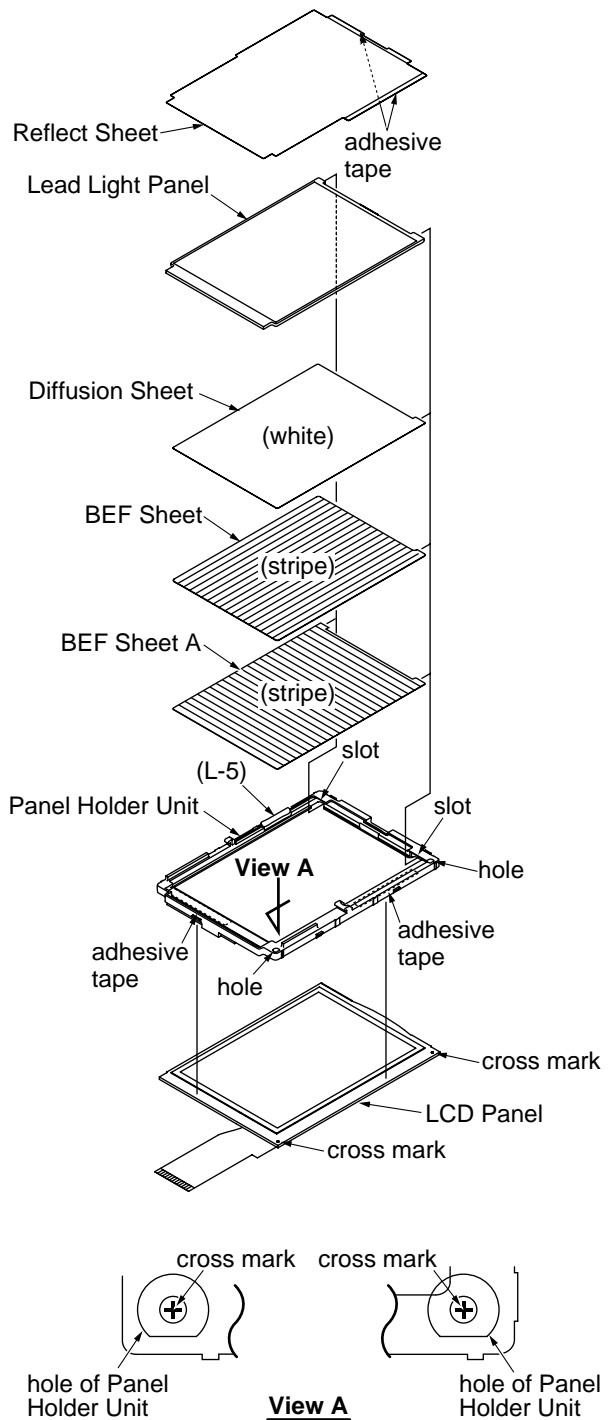

Fig. D13-2

- 4) Install the LCD Panel with adhesive tape so that the cross marks are positioned in the center of the holes in the Panel Holder Unit.

14. Removal of CCD P.C.B., Filter Rubber and Optical Filter

CAUTION:

- 1) When removing the CCD P.C.B., take care that the Optical Filter does not fall out.
- 2) Use extreme caution when removing the CCD P.C.B. as it is easily damaged by static electricity. Use a Wrist Strap while removing and installing.
- 3) Do not touch the CCD window surface.

Installation of CCD P.C.B., Filter Rubber and Optical Filter

Install in order shown below.

- 1) Install the Optical Filter correctly.
Note: Make sure that no dust gets on the Optical Filter or in the Lens Unit. Clean the Optical Filter with lens cleaning paper dampened with lens cleaner if necessary.
- 2) Install the Filter Rubber on the Optical Filter correctly as shown below.
Note: Make sure that no dust gets on the Filter Rubber.
- 3) Install the CCD P.C.B. into the Lens Unit. Then, tighten the 2 Screws (536), and secure the CCD F.P.C. on the pin.
Note: Do not touch the Lens Surface. Clean the surface with lens cleaning paper dampened with lens cleaner if necessary.

15. Installation of Zoom Motor Unit/Focus Motor Unit

Install the Zoom Motor Unit/Focus Motor Unit so that the Shaft of the Zoom Motor Unit/Focus Motor Unit is set in the Holder.

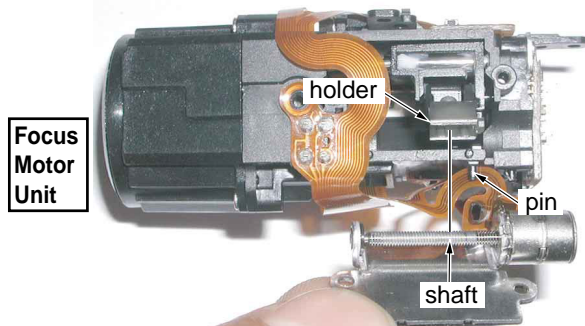
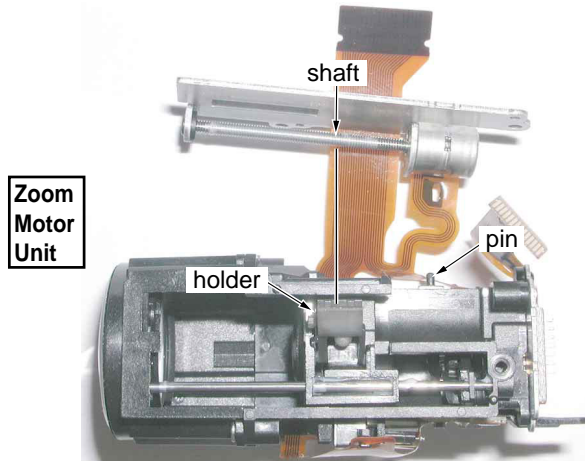

Fig. D14

16. Removal of EVF Unit

- 1) Remove the 2 Screws (433).
- 2) Slide to extend the EVF Unit.
- 3) Push to release the Locking Tab (L-1), and remove the EVF Unit. Take care not to damage the EVF F.P.C.

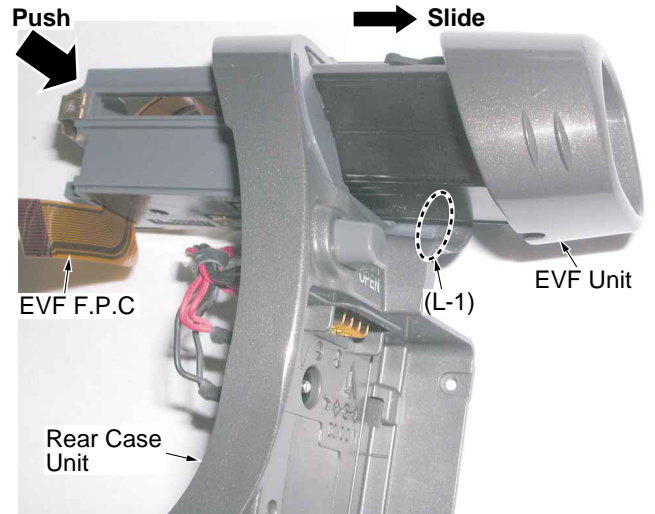
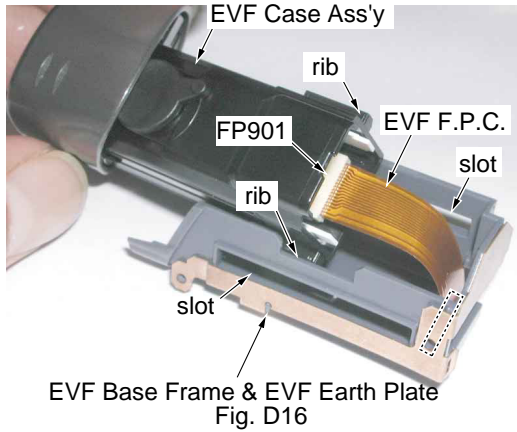

Fig. D15

17. Installation of EVF Base Frame, EVF F.P.C.

- 1) Pass the EVF F.P.C. through the EVF Base Frame hole.
- 2) Connect the EVF F.P.C. to Connector FP901.
- 3) Install the EVF Case Ass'y into EVF Base Frame so that the ribs are inserted into the slots of the EVF Base Frame.
- 4) After installing, confirm the EVF moves correctly.



18. Removal of Eye Cap

- 1) Remove the 2 Screws (533).
- 2) Remove the Eye Cap, then release the Locking Tab (L-2).

Handling cautions of EVF Lens Unit

Use extreme care when handling the EVF Lens Unit to avoid damage, dust, and spots (especially fingerprints, etc.)

Installation of EVF Lens Unit, Eye Sight Lever

- 1) Install the Eye Sight Lever into the EVF Case in the direction shown.
- 2) Install the EVF Lens Unit fitting both ribs into the EVF.
- 3) After installing, confirm that the Eye Sight Lever and EVF Lens Unit work together correctly.

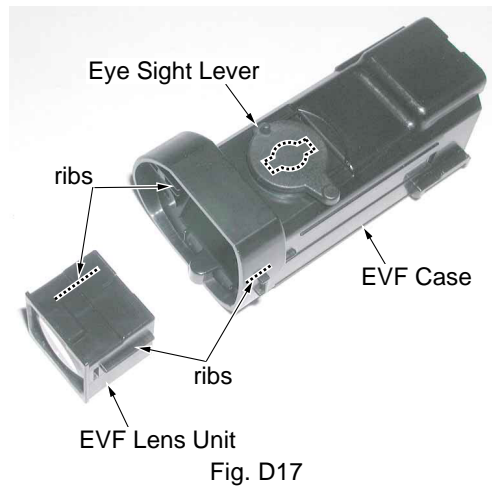

9 Measurements and Adjustments

9.1. Electrical Adjustment

9.1.1. Initial Guideline

The table below shows which adjustments are necessary according to the unit parts and individual parts to be replaced. Make sure to perform these adjustments shown below as necessary.

Adjustment Item		Replacement Parts										
		MAIN P.C.B.	IC501 (CAMERA SIGNAL PROCESS)	IC701 (FOCUS/ZOOM/MOTOR DRIVE & IRIS/HALL AMP CONTROL)	IC3001 (CAMERA DIGITAL SIGNAL PROCESS/SHUFLING)	IC3301 (VIDEO/AUDIO SIGNAL PROCESS)	IC6001 (SYSTEM MICROCONTROLLER)	IC6004 (EEPROM)	IC3201 (Flash Memory)	IC8001 (LCD RGB/EVF SIGNAL PROCESS)	CCD P.C.B.	LENS UNIT
Camera	CAM hall amplifier and Iris PWM	○	○	○	○	○	○	○	○	○	○	○
	CAM Zoom Tracking and De-focus	○	○	○	○	○	○	○	○	○	○	○
	CAM WB coarse	○	○	○	○	○	○	○	○	○	○	○
	CAM AWB 3100	○	○	○	○	○	○	○	○	○	○	○
	CAM AWB 5100	○	○	○	○	○	○	○	○	○	○	○
	CAM Revision CCD scratch	○	○	○	○	○	○	○	○	○	○	○
Video	Luminance level	○	○	○	○	○	○	○	○	○	○	
LCD	LCD Contrast	○	○	○	○	○	○	○	○	○	○	
	LCD Bright	○	○	○	○	○	○	○	○	○	○	
	LCD Sub Bright	○	○	○	○	○	○	○	○	○	○	
	LCD VCOM level	○	○	○	○	○	○	○	○	○	○	
EVF	EVF Horizontal free running	○	○	○	○	○	○	○	○	○	○	
	EVF Contrast	○	○	○	○	○	○	○	○	○	○	
	EVF Bright	○	○	○	○	○	○	○	○	○	○	
	EVF Sub Bright	○	○	○	○	○	○	○	○	○	○	
	EVF VCOM level	○	○	○	○	○	○	○	○	○	○	

Note: ○ : Adjustment Item

9.1.2. Installation of USB-SERIAL driver

Execute the "Setup.exe" file in "ComMass" folder by double clicking to install the USB-SERIAL driver.

9.1.3. COM Mode

If a Disc or SD Card is inserted, remove before operation.

To enter the PC connection (COM) mode, push the [DELETE], [RECORDING START/STOP] and [JOYSTICK CONTROL UP] simultaneously for 3 seconds without connecting the USB Cable.



<LCD Monitor>

9.1.4. Set up of PC-EVR Adjustment Program

1. Turn on the PC and install the PC-EVR Adjustment Program into the PC.
2. Execute the "kdr2006.exe" file by double clicking to start up the PC-EVR Adjustment Program.
The main menu will be displayed.
3. Select the appropriate model.
4. Turn on the camcorder and set to PC connection (COM) mode. Then click "Start".

① Select the appropriate model.

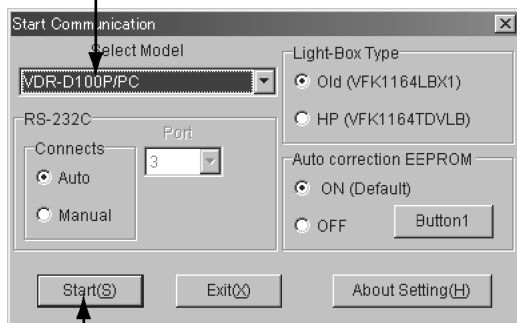

② Click to start.

5. When the communication is complete, the dialog will appear.

Click "Yes," and "Save" to save the EEPROM data.

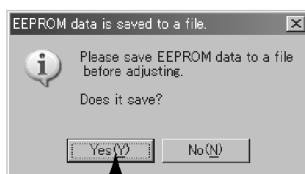

③ Click.

Fig. E2-2

6. When saving EEPROM data is complete, the menu will appear.

To perform each adjustment, display the adjustment menu by selecting from "Camera Adjust," "Vcr Adjust," "LCD Adjust" or "EVR Adjust" and select each adjustment item.

④ Select the desired menu.

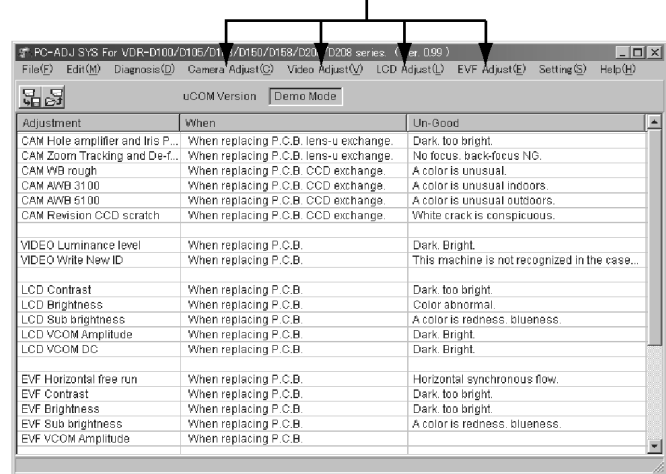

Fig. E2-3

Note:

The adjusted data is stored in the EEPROM IC after each adjustment.

7. After adjustment, to close the software, select "Exit" in the File menu or close the window.

⑤ Select "Exit" or close the window.

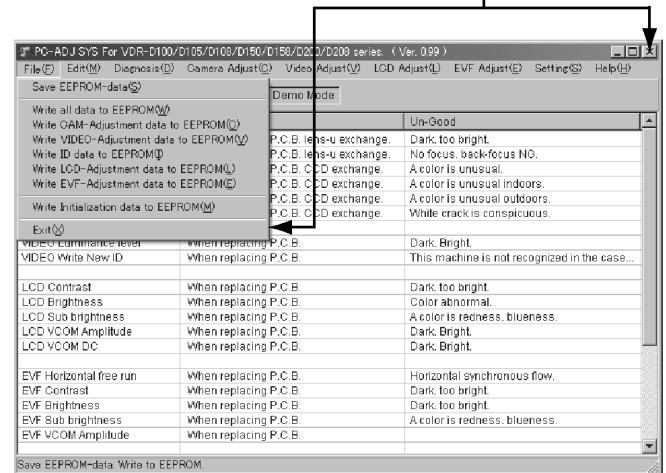

Fig. E2-4

8. To release the PC connection (COM) mode, push the [DELETE], [RECORDING START/STOP] an [JOYSTICK CONTROL UP] simultaneously for 3 seconds without connecting the USB Cable.

10 Maintenance

10.1. Cleaning Lens, Viewfinder and LCD Panel

Do not touch the surface of the lens, Viewfinder and LCD Panel with your hand.

When cleaning the lens, use air-blower to blow off the dust.

When cleaning the LCD Panel, dampen the lens cleaning paper with lens cleaner, and gently wipe the surface.

Note:

Lens cleaning paper and lens cleaner are available at camera shops, etc.

10.2. Cleaning disc and optical pickup

(1) Cleaning disc

- 1) Use the provided disc cleaning cloth, or a soft, dry cloth to lightly clean the disc from the inner to outer edges in axial direction.
- 2) If the dirt cannot be removed with the above procedure, put a few droplets of absolute alcohol in a soft, dry cloth, and use it to lightly clean the disc from the inner to outer edges in axial direction.

Disc cleaning cloth provided or soft and dry cloth

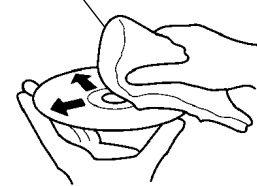

Cleaning Disc

(2) Cleaning optical pickup

Note:

Do not clean the optical pickup needlessly. The optical pickup is a precision component. Repeated cleaning could cause a fault.

- 1) Attach the AC adapter/charger or battery (power supply), and then slide the DISC EJECT switch to open the disc insertion block.
- 2) Remove the AC adapter/charger or battery (power supply).

Caution:

Laser light striking the eye may cause your eyesight to be lost: For safety, be sure to remove any power supply (AC adaptor/charger, battery, etc.) from the DVD video camera/recorder before starting work.

<CSA requirement>

CAUTION: VISIBLE LASER RADIATION DO NOT STARE INTO THE BEAM OR VIEW DIRECTLY WITH OPTICAL INSTRUMENTS CLASS 2M

- 3) Check to see whether the optical pickup is dirty. If it is not dirty, use the following procedure to clean it:
 - a) Apply one drop of absolute alcohol on a clean cotton swab (*1). Lens cleaner liquid for CD/DVD (generally available) may be substituted for absolute alcohol.
 - b) Lightly swab the optical pickup to clean it. Using too much force during cleaning may cause a fault to occur.

*1: Always use a fresh cotton swab free from any additive or chemical.

Cotton swab Turntable

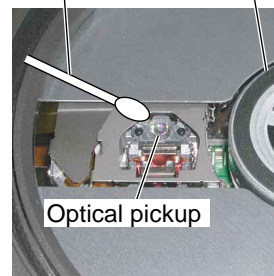

Cleaning Optical Pickup

Do not spray insecticides or volatile chemicals onto the unit.

If the unit is sprayed with such chemicals, its body may be marred and the surface finish may peel off.
Do not leave rubber or plastic products in contact with the unit for a long time.

When you use the unit in a sandy or dusty place such as a beach, do not let sand or fine dust get into the body and terminals of the unit.

Also, keep the unit away from sea water.

Sand or dust may damage the unit. (Care should be taken when inserting and removing a disc or a card.)
If sea water splashes onto the unit, wipe off the water with a well wrung cloth. Then wipe the unit again with a dry cloth.

When carrying the unit, do not drop or bump it.

A strong impact can break the unit's casing, causing it to malfunction.

Do not use benzine, paint thinner or alcohol for cleaning the unit.

Before cleaning, detach the battery or pull out the AC cable from the AC outlet.

The camera body may be discolored and the surface finish may peel off.

Wipe the unit with a soft dry cloth to remove dust and fingerprints. To remove stubborn stains, thoroughly wring a cloth that has been soaked in a neutral detergent diluted with water and wipe the unit with it. Afterwards, wipe it with a dry cloth.

When you use a chemical dust cloth, follow the instructions that came with the cloth.

Do not use a commercial available 8 cm (3 z) CD lens cleaner.

Using 8 cm (3 z) CD lens cleaner could cause this unit to malfunction.

11 Block Diagrams

OVERALL BLOCK DIAGRAM

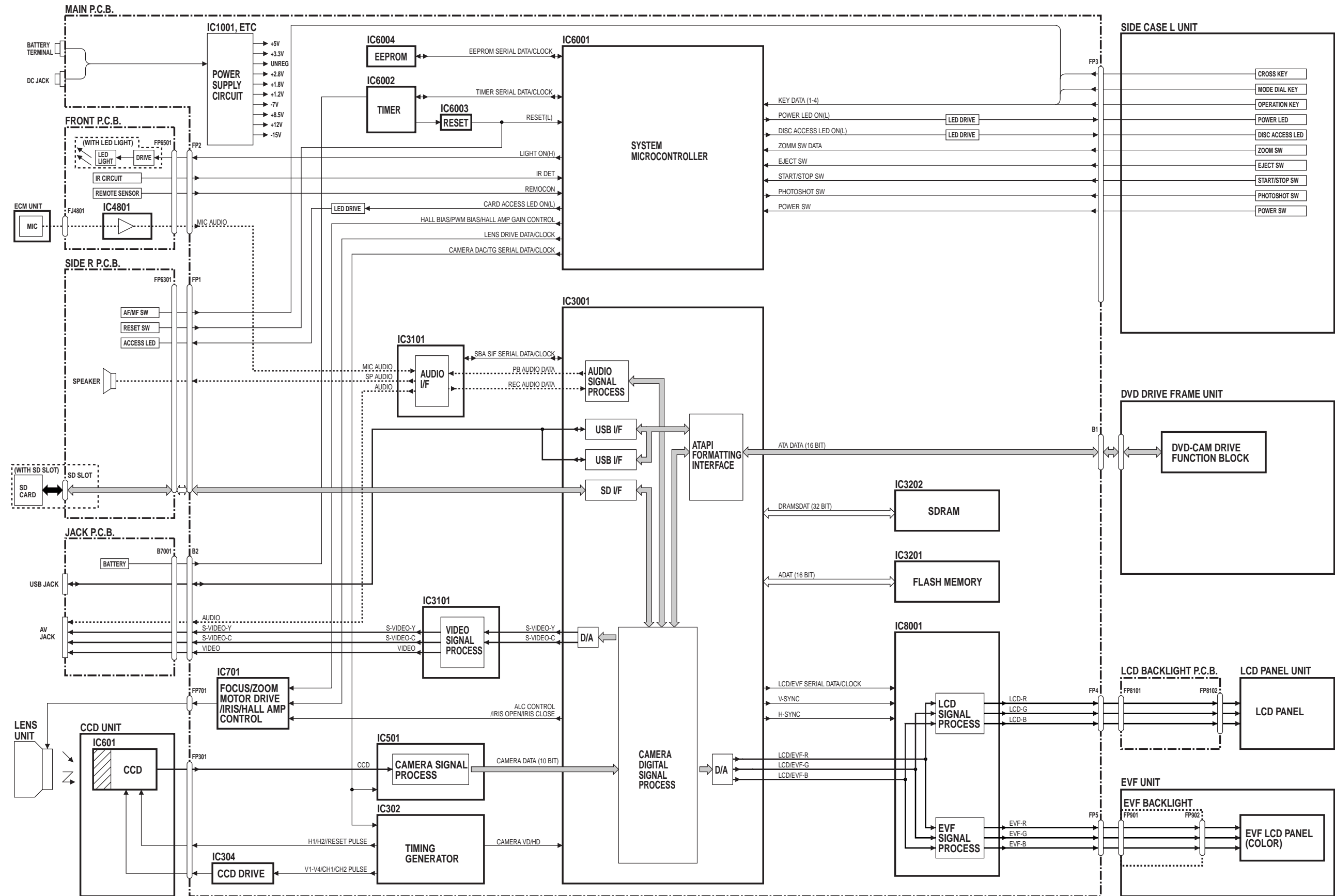

OVERALL BLOCK DIAGRAM
 VDR-D100EG/VDR-D100EB/VDR-D150E/VDR-D150EB/VDR-D150EF/VDR-D150EG/VDR-D150EP/VDR-D150EE
 /VDR-D150GC/VDR-D150GN/VDR-D150GCS/VDR-D150SG/VDR-D152EG/VDR-D158GK

CCD DRIVE BLOCK DIAGRAM

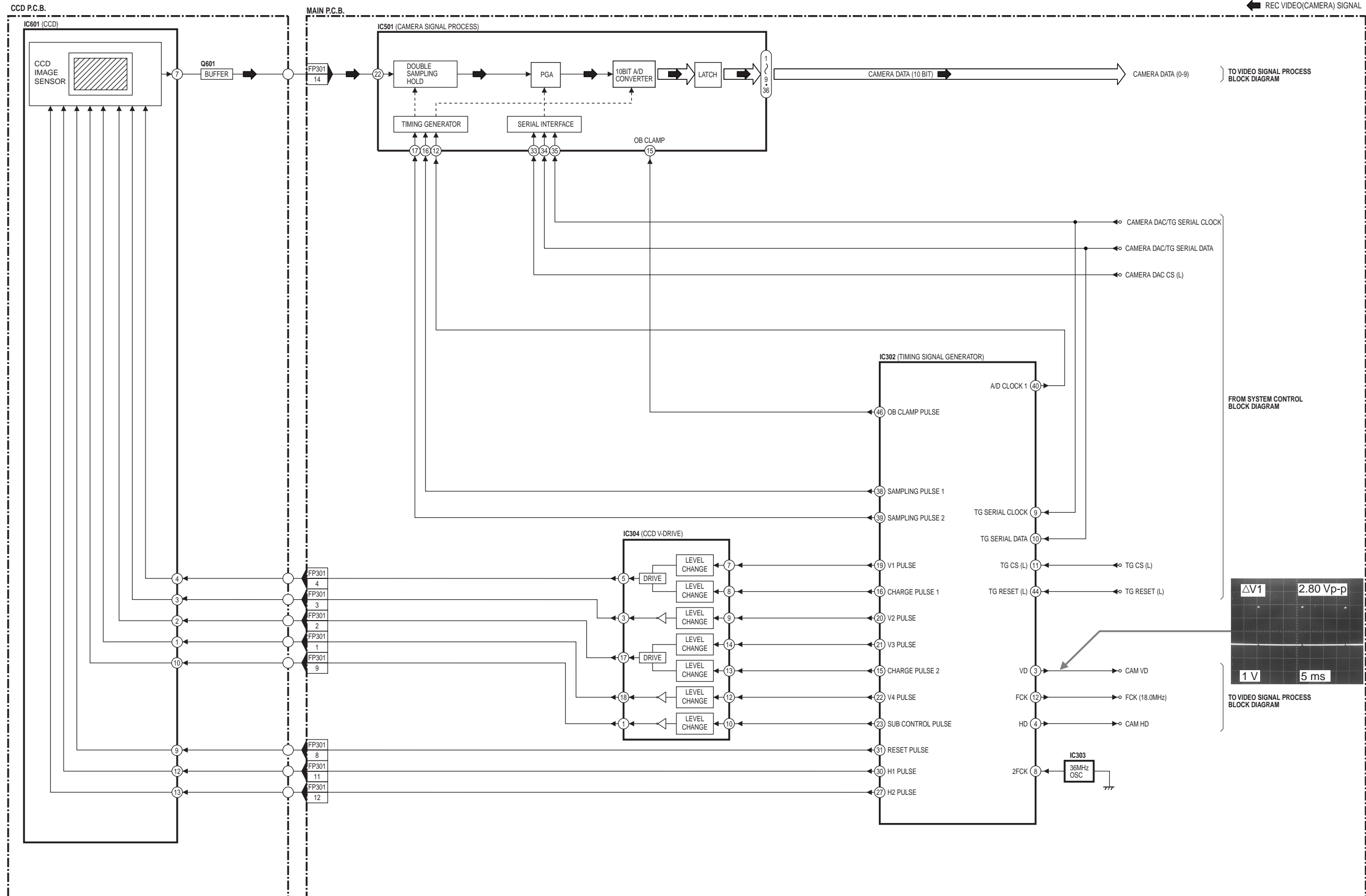

CCD DRIVE BLOCK DIAGRAM
VDR-D100EG/VDR-D100EB/VDR-D150E/VDR-D150EB/VDR-D150EF/VDR-D150EG/VDR-D150EP/VDR-D150EE
/VDR-D150GC/VDR-D150GN/VDR-D150GCS/VDR-D150SG/VDR-D152EG/VDR-D158GK

VIDEO SIGNAL PROCESS BLOCK DIAGRAM

← REC VIDEO SIGNAL ← PB VIDEO SIGNAL ← REC AUDIO SIGNAL ← PB AUDIO SIGNAL

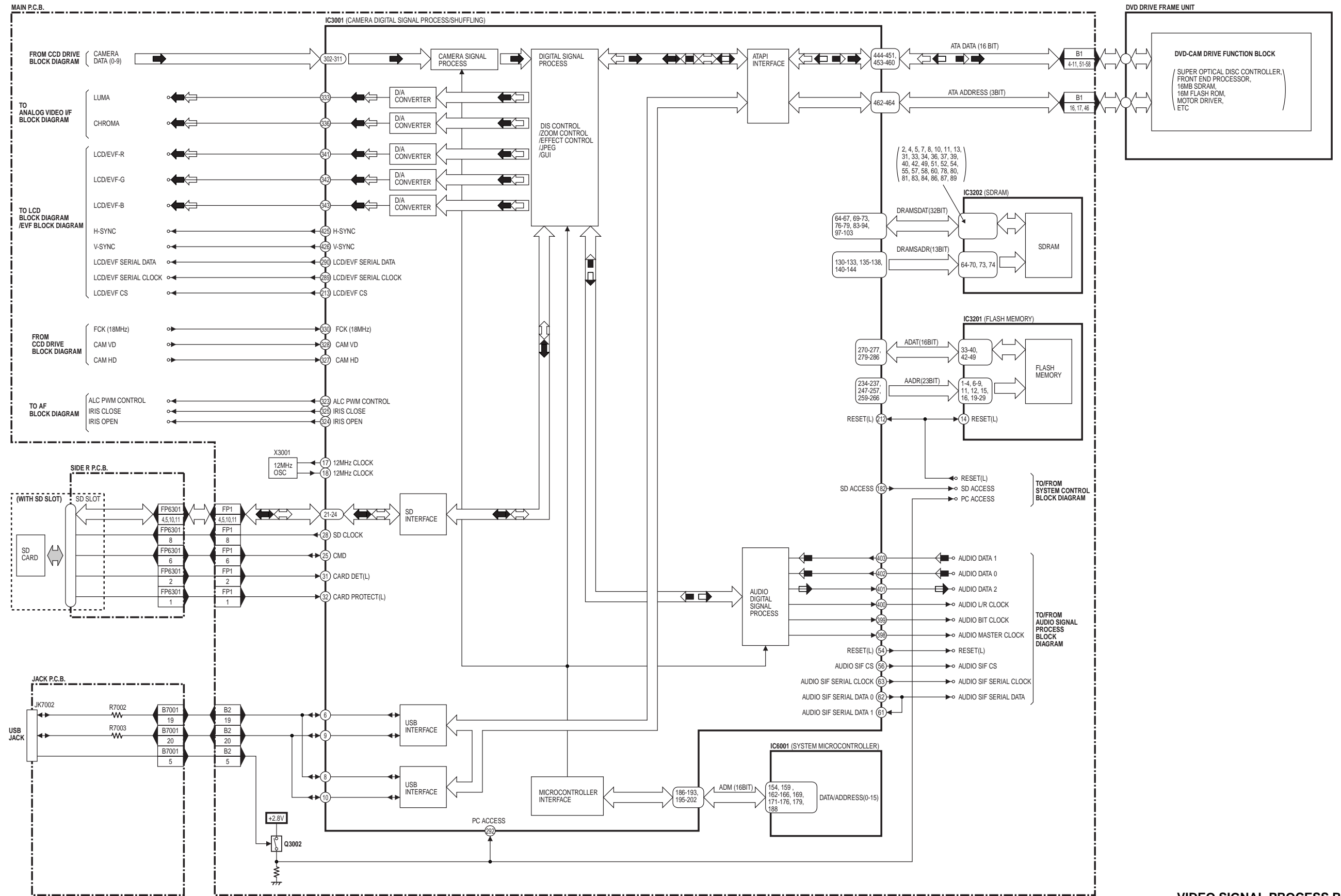

VIDEO SIGNAL PROCESS BLOCK DIAGRAM
VDR-D100EG/VDR-D100EB/VDR-D150E/VDR-D150EB/VDR-D150EF/VDR-D150EG/VDR-D150EP/VDR-D150EE
/VDR-D150GC/VDR-D150GN/VDR-D150GCS/VDR-D150SG/VDR-D152EG/VDR-D158GK

ANALOG VIDEO I/F BLOCK DIAGRAM

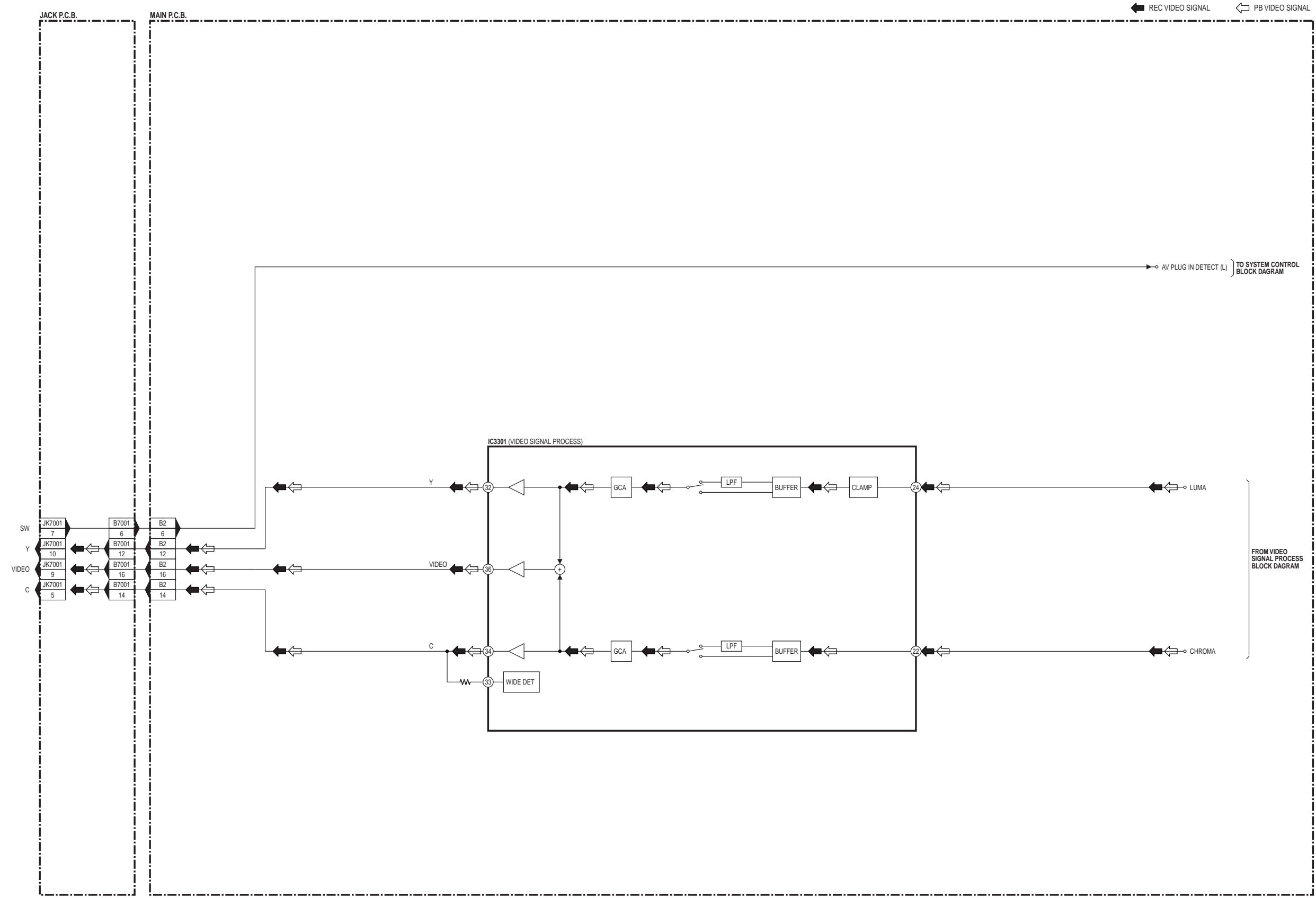

ANALOG VIDEO I/F BLOCK DIAGRAM
 VDR-D100EG/VDR-D100EB/VDR-D150E/VDR-D150EB/VDR-D150EF/VDR-D150EG/VDR-D150EP/VDR-D150EE
 /VDR-D150GC/VDR-D150GN/VDR-D150GCS/VDR-D150SG/VDR-D152EG/VDR-D158GK

AUDIO SIGNAL PROCESS BLOCK DIAGRAM

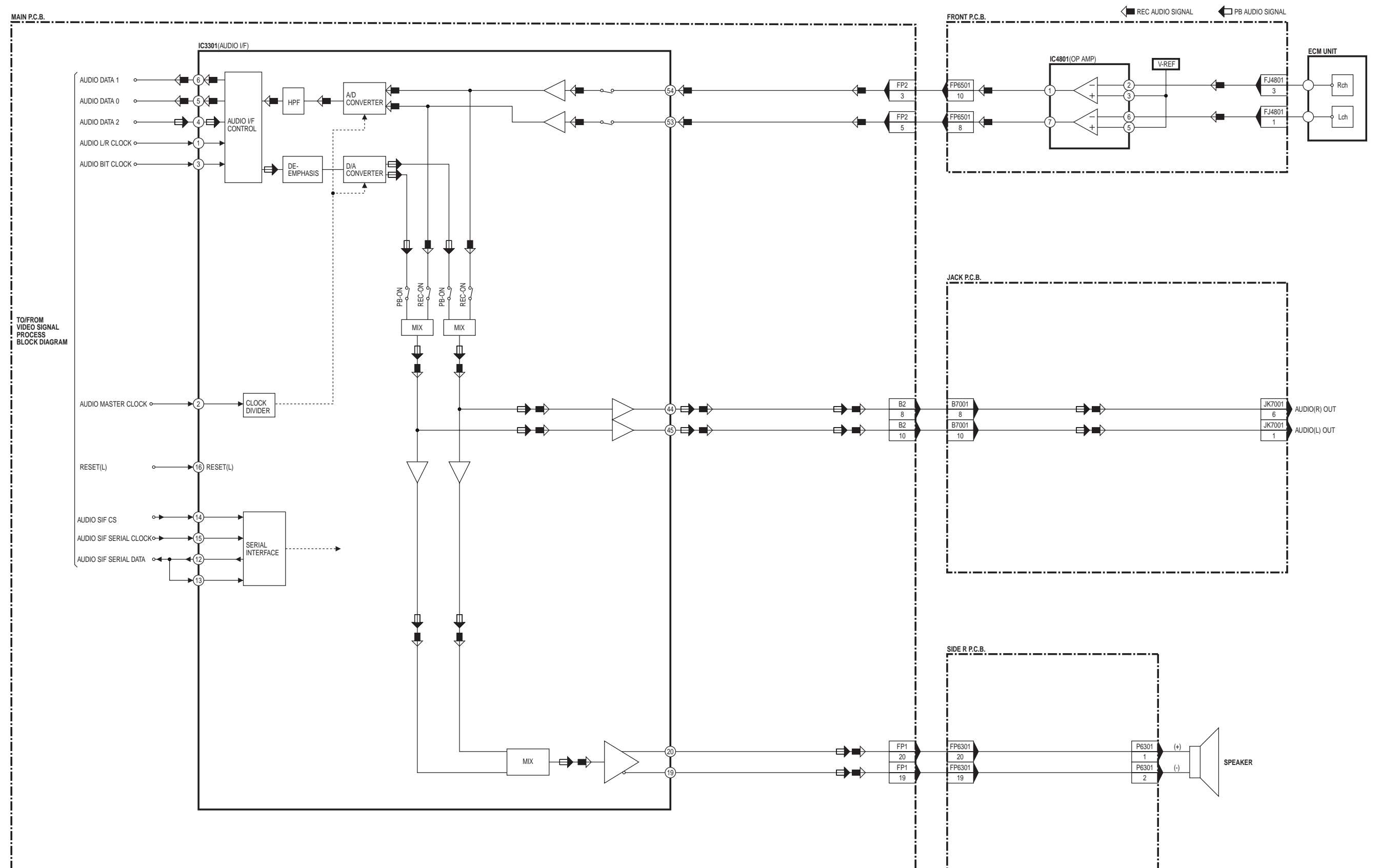

AUDIO SIGNAL PROCESS BLOCK DIAGRAM
VDR-D100EG/VDR-D100EB/VDR-D150E/VDR-D150EB/VDR-D150EF/VDR-D150EG/VDR-D150EP/VDR-D150EE
/VDR-D150GC/VDR-D150GN/VDR-D150GCS/VDR-D150SG/VDR-D152EG/VDR-D158GK

SYSTEM CONTROL BLOCK DIAGRAM

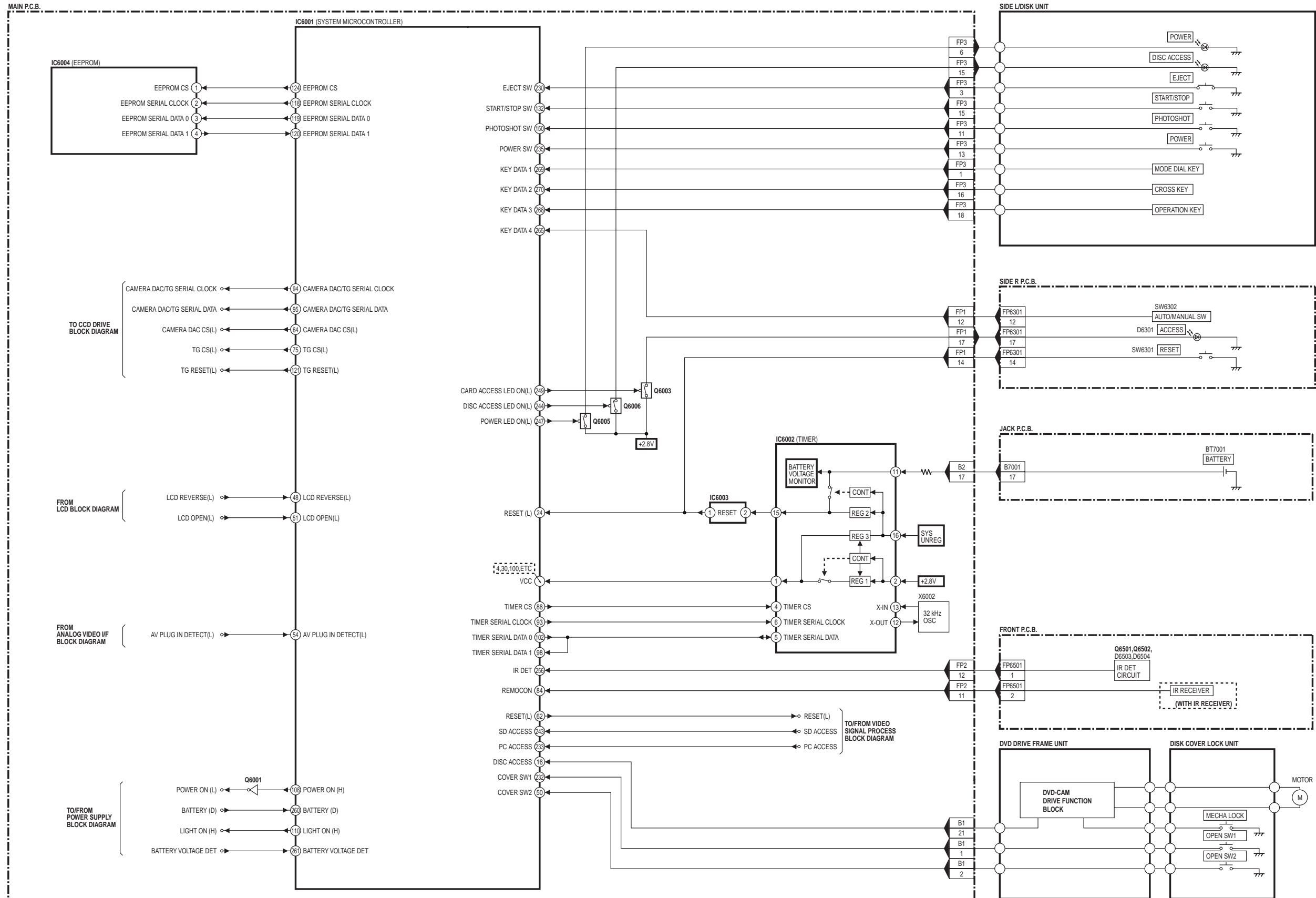

SYSTEM CONTROL BLOCK DIAGRAM
VDR-D100EG/VDR-D100EB/VDR-D150E/VDR-D150EB/VDR-D150EF/VDR-D150EG/VDR-D150EP/VDR-D150EE
/VDR-D150GC/VDR-D150GN/VDR-D150GCS/VDR-D150SG/VDR-D152EG/VDR-D158GK

AF BLOCK DIAGRAM

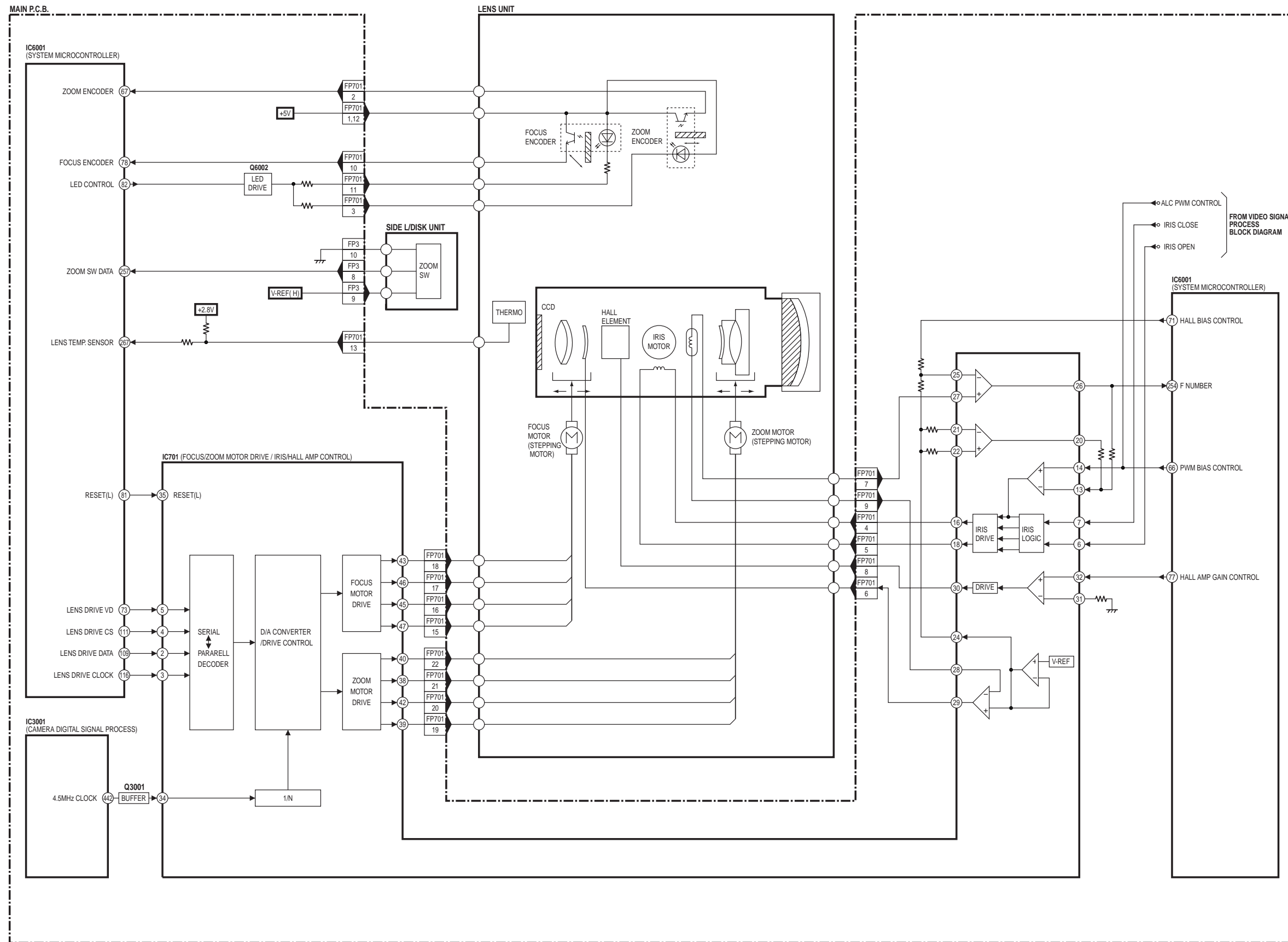

AF BLOCK DIAGRAM
VDR-D100EG/VDR-D100EB/VDR-D150E/VDR-D150EB/VDR-D150EF/VDR-D150EG/VDR-D150EP/VDR-D150EE
/VDR-D150GC/VDR-D150GN/VDR-D150GCS/VDR-D150SG/VDR-D152EG/VDR-D158GK

LCD DRIVE BLOCK DIAGRAM

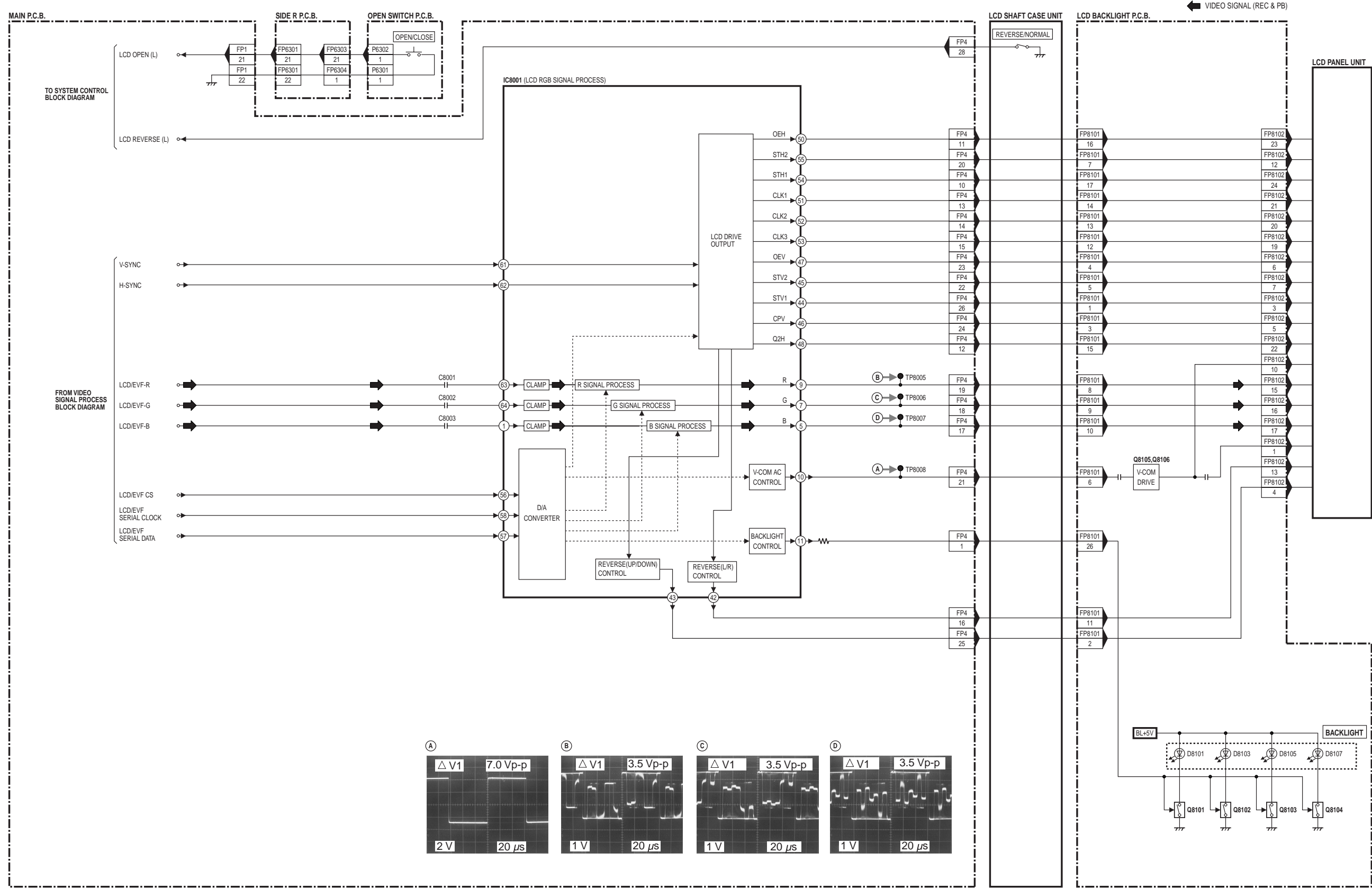

LCD DRIVE BLOCK DIAGRAM
 VDR-D100EG/VDR-D100EB/VDR-D150E/VDR-D150EB/VDR-D150EF/VDR-D150EG/VDR-D150EP/VDR-D150EE
 /VDR-D150GC/VDR-D150GN/VDR-D150GCS/VDR-D150SG/VDR-D152EG/VDR-D158GK

EVF BLOCK DIAGRAM

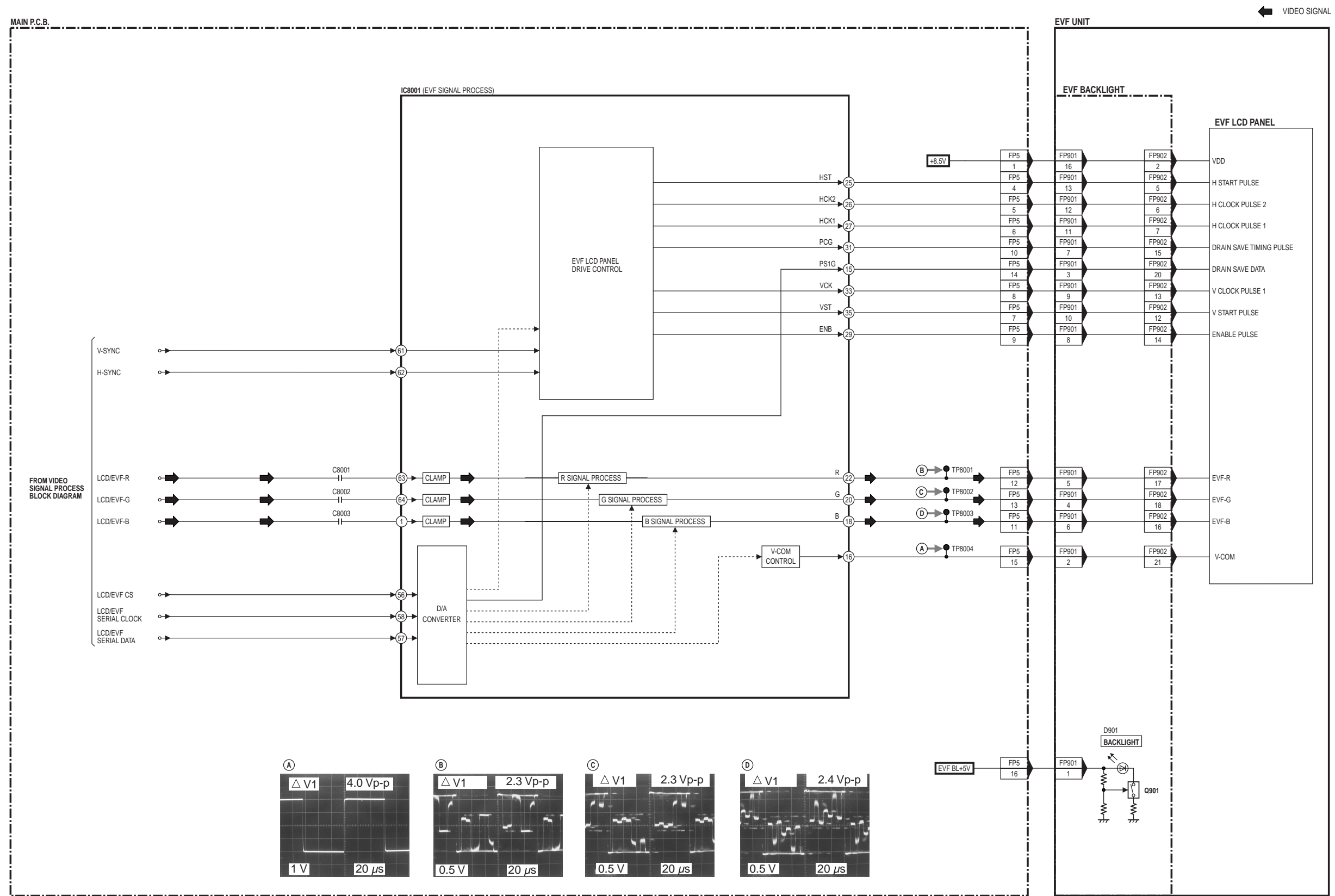

EVF BLOCK DIAGRAM

VDR-D100EG/VDR-D100EB/VDR-D150E/VDR-D150EB/VDR-D150EF/VDR-D150EG/VDR-D150EP/VDR-D150EE /VDR-D150GC/VDR-D150GN/VDR-D150GCS/VDR-D150SG/VDR-D152EG/VDR-D158GK

POWER SUPPLY BLOCK DIAGRAM

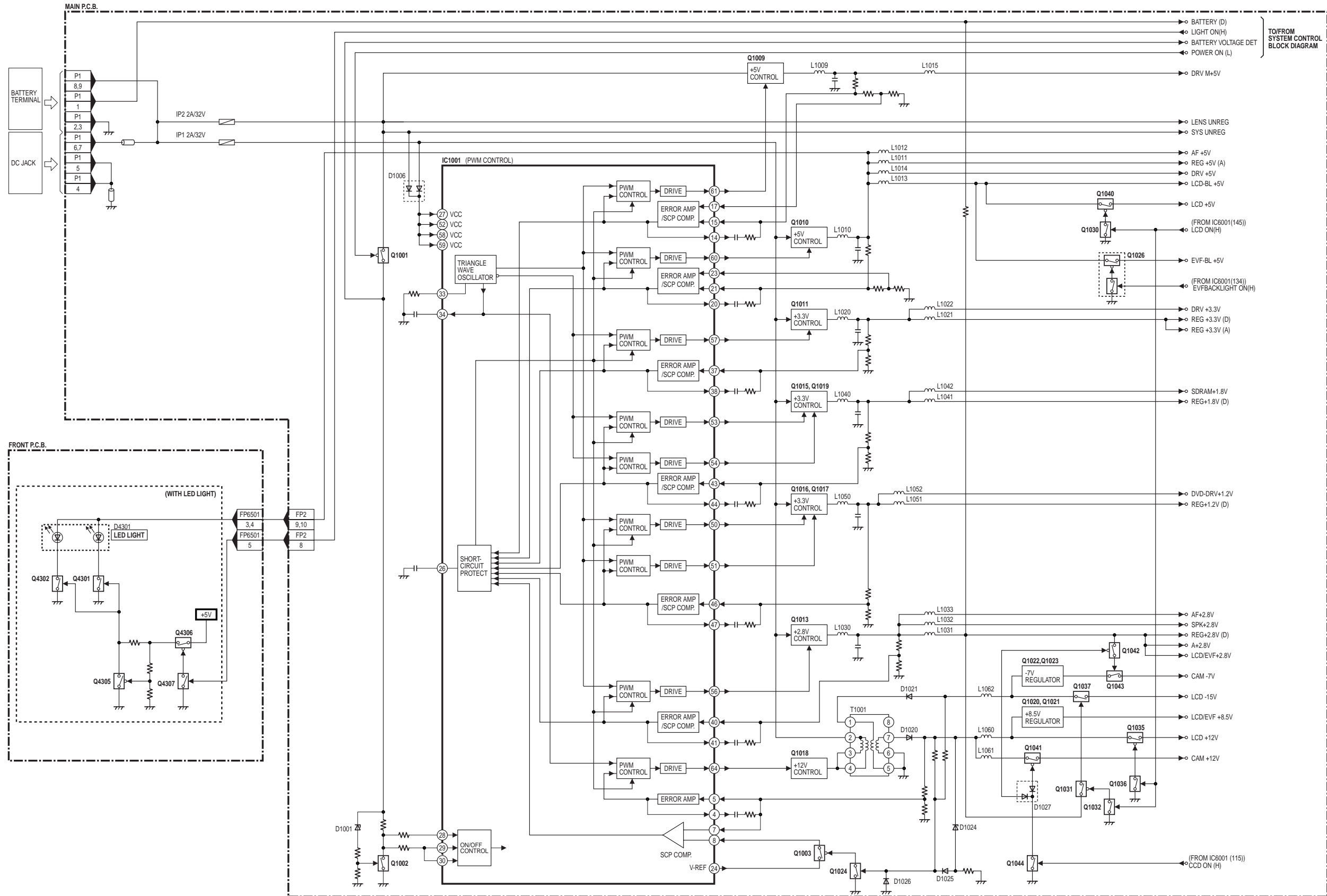

POWER SUPPLY BLOCK DIAGRAM

VDR-D100EG/VDR-D100EB/VDR-D150E/VDR-D150EB/VDR-D150EF/VDR-D150EG/VDR-D150EP/VDR-D150EE
/VDR-D150GC/VDR-D150GN/VDR-D150GCS/VDR-D150SG/VDR-D152EG/VDR-D158GK

12 Schematic Diagrams

12.1. SCHEMATIC DIAGRAM & CIRCUIT BOARD LAYOUT NOTES

1. Important safety notice

Components identified by the sign  have special characteristics important for safety. When replacing any of these components, use only the specified parts.

2. Do not use the part numbers shown on these drawings for ordering.

The correct part number and part value is shown in the parts list, and may be slightly different or amended since this drawing was prepared.

3. Use only original replacement parts:

To maintain original function and reliability of repaired units, use only original replacement parts which are listed with their part numbers in the parts list section of the service manual.

4. Parts different in shape or size may be used.

However, only interchangeable parts will be supplied as service replacement parts.

5. Test point information

 : Test point with no test pin.

Schematic Diagram Notes

1. Indication for Zener Voltage of Zener Diodes

The Zener Voltages of Zener Diodes are indicated as such on Schematic Diagrams.

Example:
(6.2V).....Zener Voltage

2. How to identify Connectors

Each connector is labeled with a Connector No. and Pin No. Indicating what it is connected to (its counter part). Use the interconnection schematic diagram to find the connection between associated connectors.

Example:

The connections between two P.C.B.s are shown below.

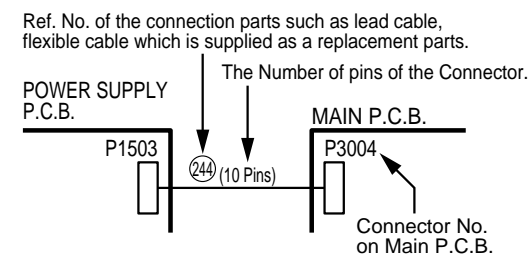

3. Parts marked "PT" are not used in any models included in this service model.



Signal Waveform Note

How to read Signal Waveform

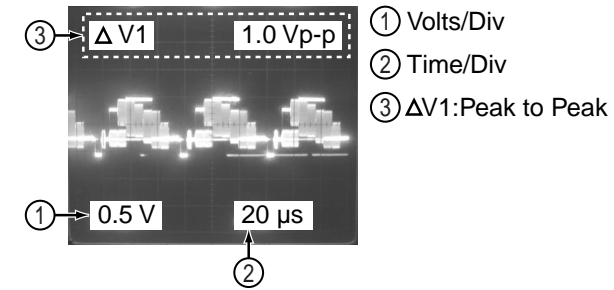

Voltage Chart Note

Voltage Measurement

- a. Color bar signal in SP mode.
- b. ---:Unmeasurable or not necessary to measure.

Circuit Board Layout Note

Circuit Board Layouts show components installed for various models.

For proper parts content for the model you are servicing, please refer to the schematic diagram and parts list.

NOTE:

Circuit Board Layouts include components which are not used.

Model Number Indication

Model numbers are indicated without "VDR-D."

SCHEMATIC DIAGRAM & CIRCUIT BOARD LAYOUT NOTES
VDR-D100EG/VDR-D100EB/VDR-D150E/VDR-D150EB/VDR-D150EF
/VDR-D150EG/VDR-D150EP/VDR-D150EE/VDR-D150GC/VDR-D150GN
/VDR-D150GCS/VDR-D150SG/VDR-D152EG/VDR-D158GK

12.2. FRONT SCHEMATIC DIAGRAM

FRONT SCHEMATIC DIAGRAM

NOTE: For placing a purchase order of the parts, be sure to use the part number listed in the parts list. Do not use the part number on this diagram.

NOTE: PARTS MARKED "PT" ARE NOT USED.

NOTE: FOR SCHEMATIC DIAGRAM AND CIRCUIT BOARD LAYOUT NOTES, REFER TO BEGINNING OF SCHEMATIC SECTION.

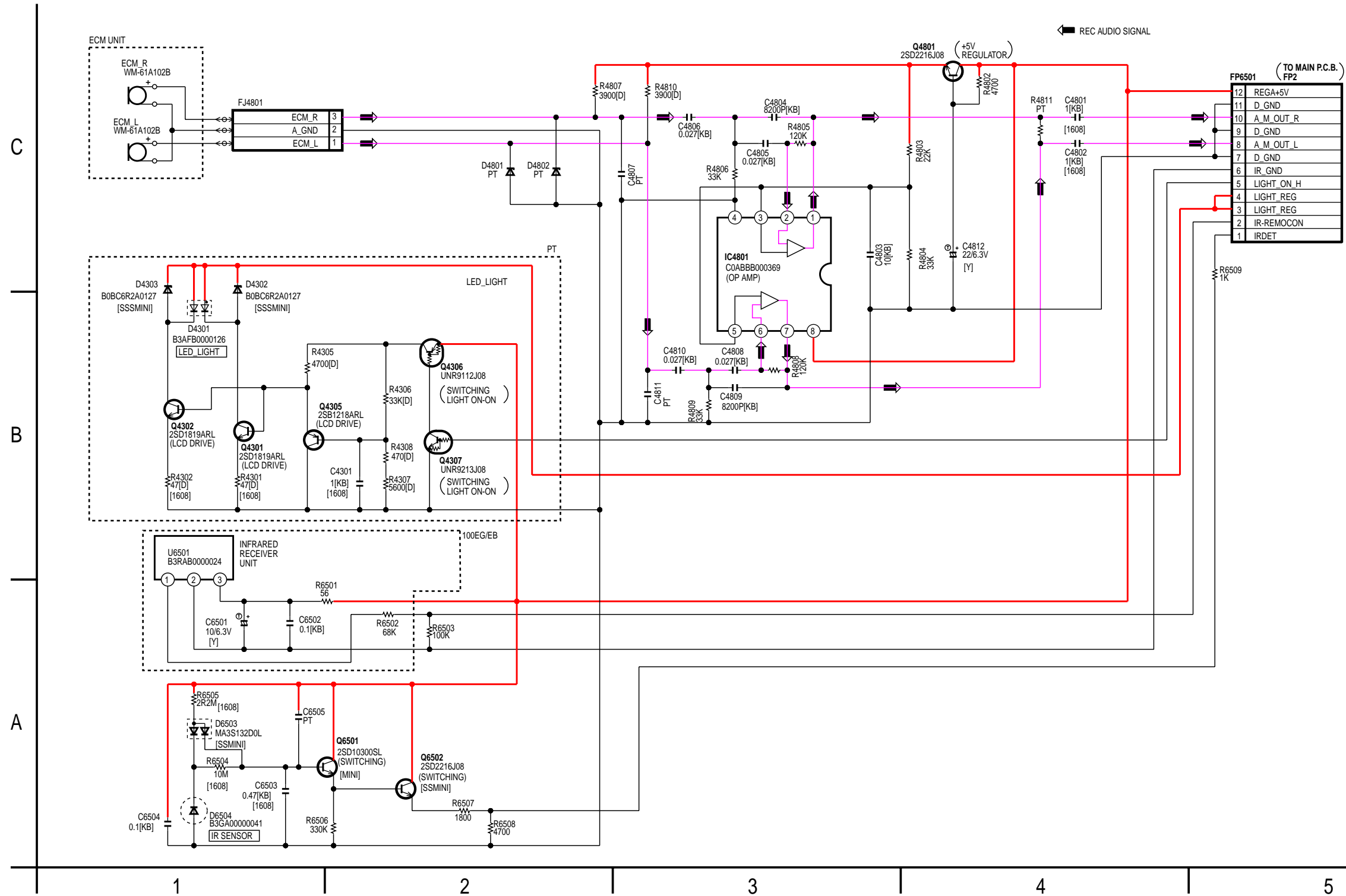

LINK TO VOLTAGE CHART

LSJB8316

FRONT SCHEMATIC DIAGRAM

VDR-D100EG/VDR-D100EB/VDR-D150E/VDR-D150EB/VDR-D150EF/VDR-D150EG/VDR-D150EP/VDR-D150EE

/VDR-D150GC/VDR-D150GN/VDR-D150GCS/VDR-D150SG/VDR-D152EG/VDR-D158GK

12.3. SIDE R SCHEMATIC DIAGRAM

SIDE R SCHEMATIC DIAGRAM

NOTE: For placing a purchase order of the parts, be sure to use the part number listed in the parts list. Do not use the part number on this diagram.

NOTE: PARTS MARKED "PT" ARE NOT USED.

NOTE: FOR SCHEMATIC DIAGRAM AND CIRCUIT BOARD LAYOUT NOTES, REFER TO BEGINNING OF SCHEMATIC SECTION.

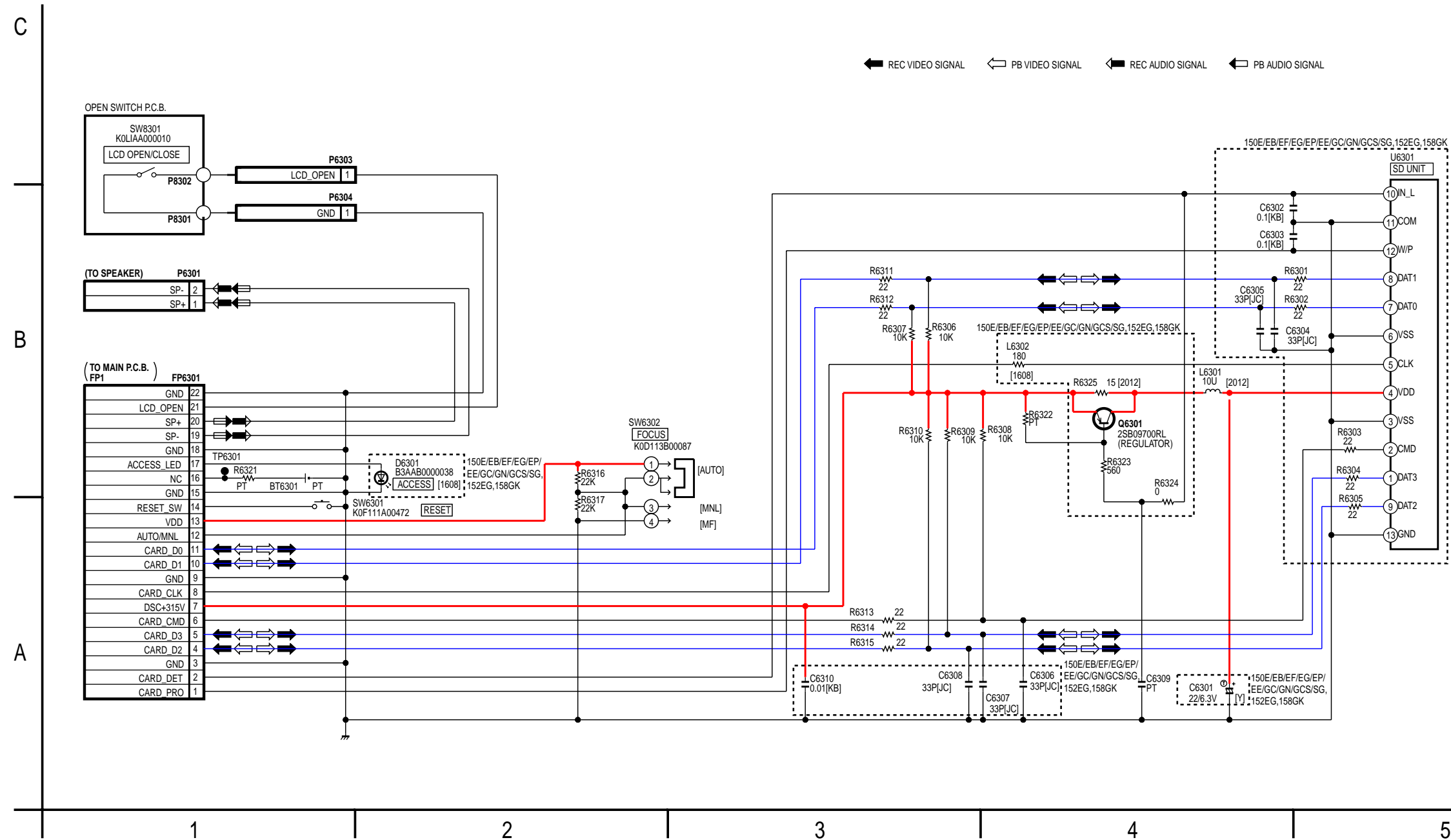

12.5. JACK / EVF BACKLIGHT / DISK COVER LOCK SCHEMATIC DIAGRAMS

NOTE: For placing a purchase order of the parts, be sure to use the part number listed in the parts list. Do not use the part number on this diagram.

NOTE: PARTS MARKED "PT" ARE NOT USED.

NOTE: FOR SCHEMATIC DIAGRAM AND CIRCUIT BOARD LAYOUT NOTES, REFER TO BEGINNING OF SCHEMATIC SECTION.

JACK SCHEMATIC DIAGRAM

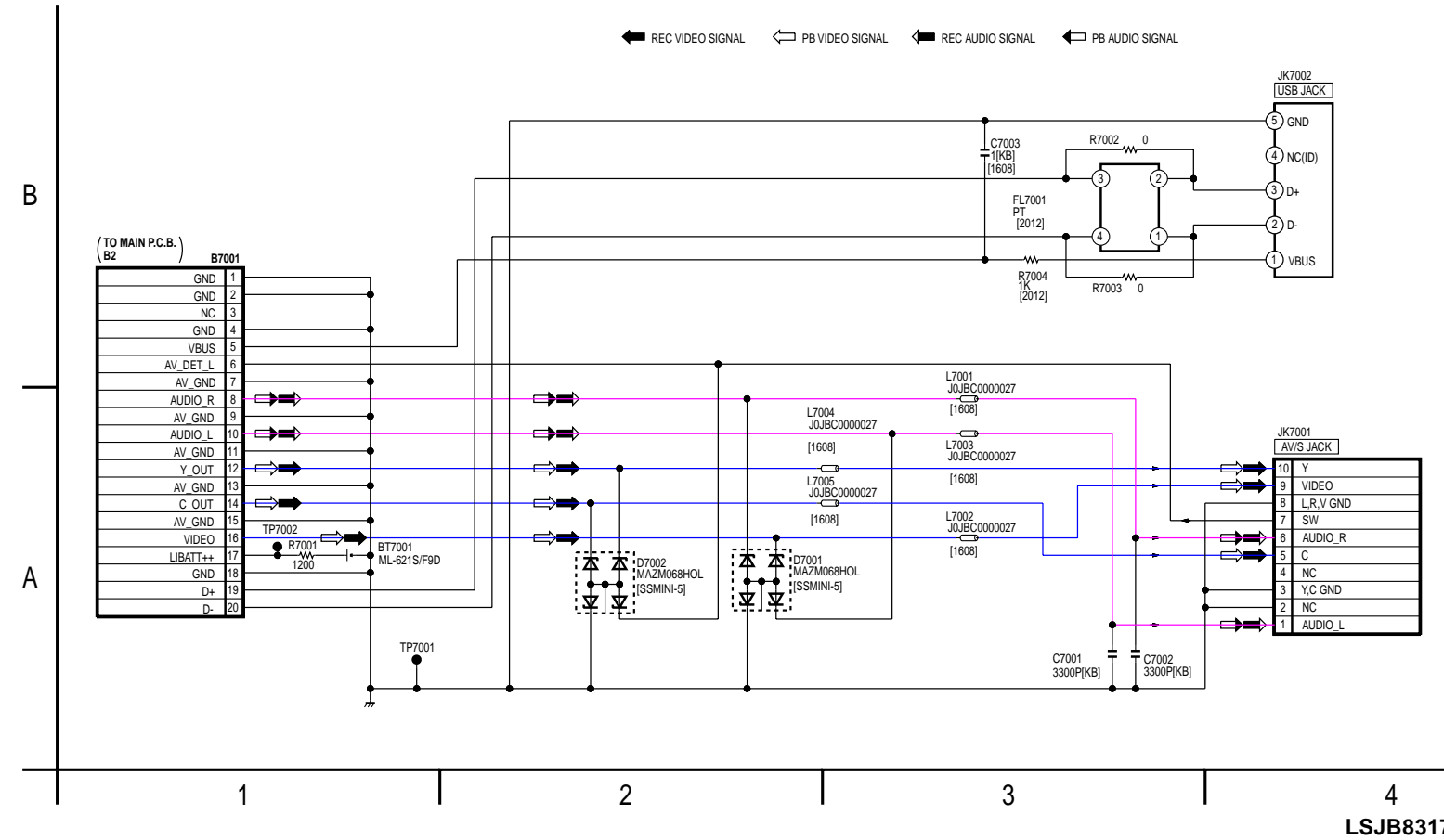

EVF BACKLIGHT SCHEMATIC DIAGRAM

"FOR REFERENCE ONLY"

NOTE: EVF BACKLIGHT IS NOT SERVICEABLE AND IS SUPPLIED AS A UNIT ONLY FOR REPLACEMENT.

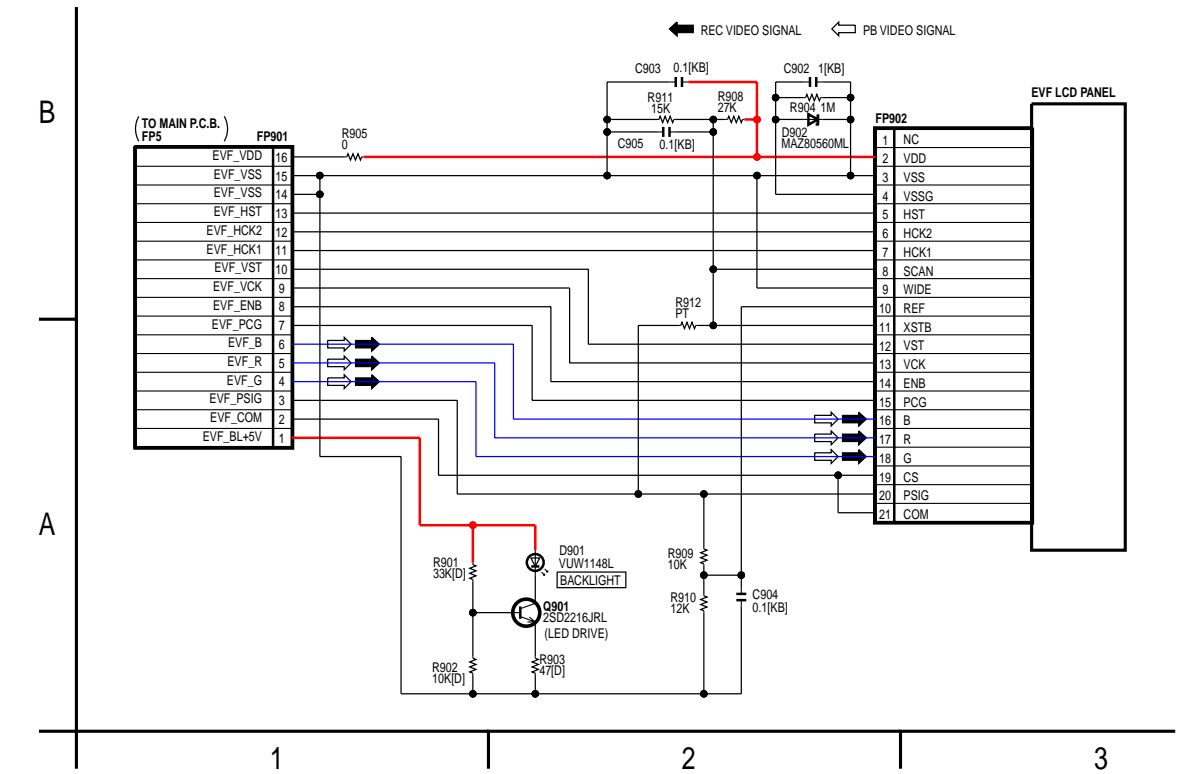

DISK COVER LOCK SCHEMATIC DIAGRAM

"FOR REFERENCE ONLY"

NOTE: DISK COVER LOCK UNIT IS NOT SERVICEABLE AND IS SUPPLIED AS A UNIT ONLY FOR REPLACEMENT.

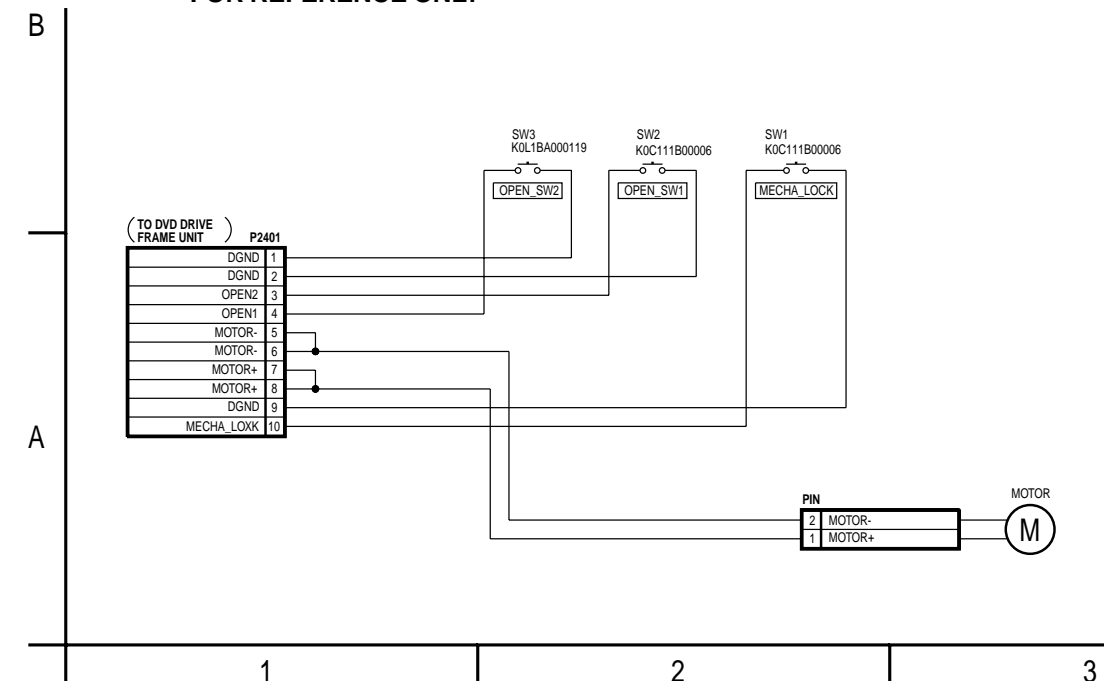

JACK SCHEMATIC DIAGRAM
 EVF BACKLIGHT SCHEMATIC DIAGRAM
 DISK COVER LOCK SCHEMATIC DIAGRAM
 VDR-D100EG/VDR-D100EB/VDR-D150E/VDR-D150EB/VDR-D150EF/VDR-D150EG/VDR-D150EP/VDR-D150EE
 /VDR-D150GC/VDR-D150GN/VDR-D150GCS/VDR-D150SG/VDR-D152EG/VDR-D158GK

12.6. CCD / LCD SW / SIDE L/DISK SCHEMATIC DIAGRAMS

NOTE: For placing a purchase order of the parts, be sure to use the part number listed in the parts list. Do not use the part number on this diagram.

NOTE: PARTS MARKED "PT" ARE NOT USED.

NOTE: FOR SCHEMATIC DIAGRAM AND CIRCUIT BOARD LAYOUT NOTES, REFER TO BEGINNING OF SCHEMATIC SECTION.

CCD SCHEMATIC DIAGRAM "FOR REFERENCE ONLY"

NOTE: CCD P.C.B. IS NOT SERVICEABLE AND IS SUPPLIED AS A UNIT ONLY FOR REPLACEMENT.

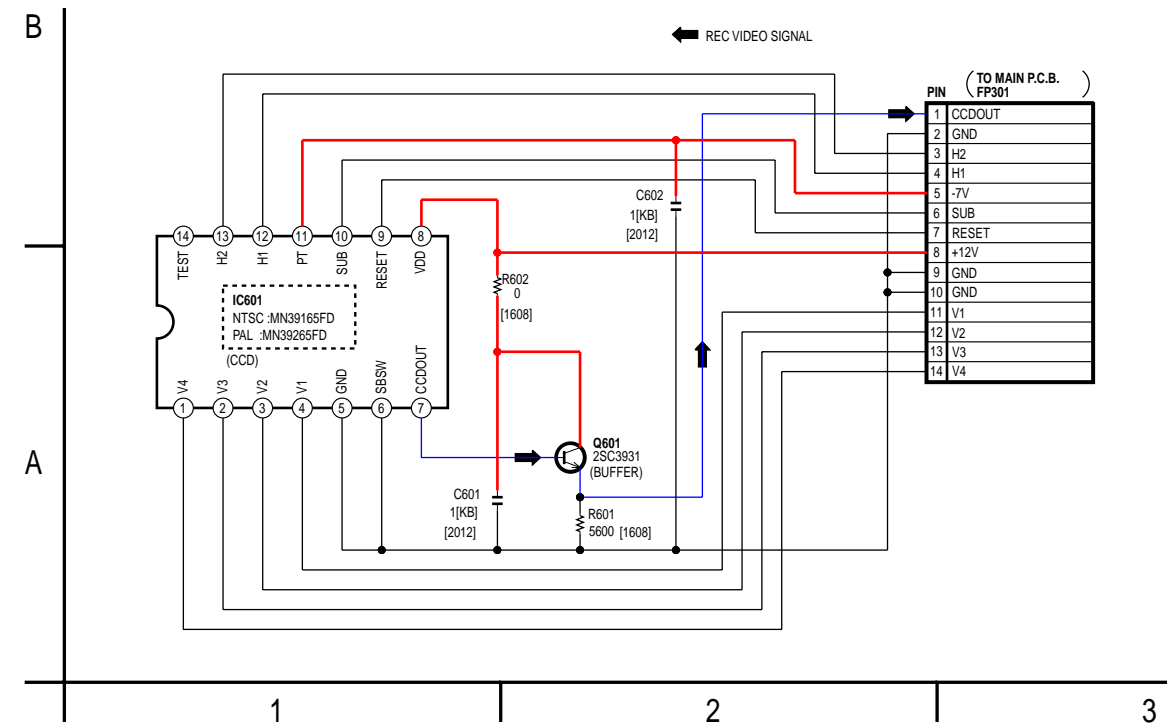

LCD SW SCHEMATIC DIAGRAM "FOR REFERENCE ONLY"

NOTE: LCD SW IS NOT SERVICEABLE AND IS SUPPLIED AS A LCD SHAFT CASE UNIT ONLY FOR REPLACEMENT.

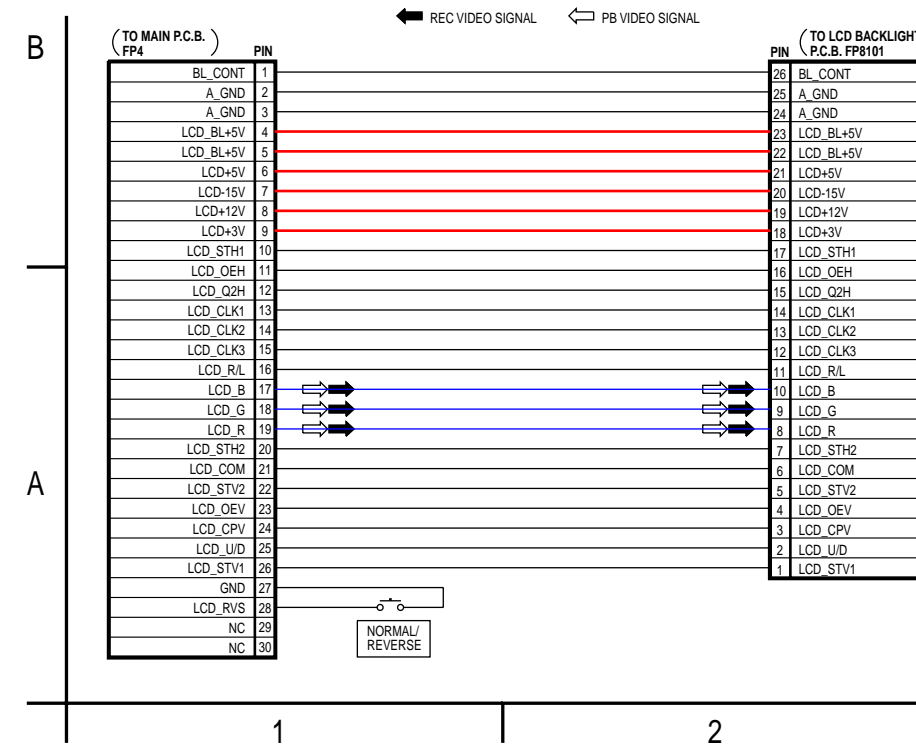

SIDE L / DISK SCHEMATIC DIAGRAM "FOR REFERENCE ONLY"

NOTE: SIDE L/DISK UNIT IS NOT SERVICEABLE AND IS SUPPLIED AS A UNIT ONLY FOR REPLACEMENT.

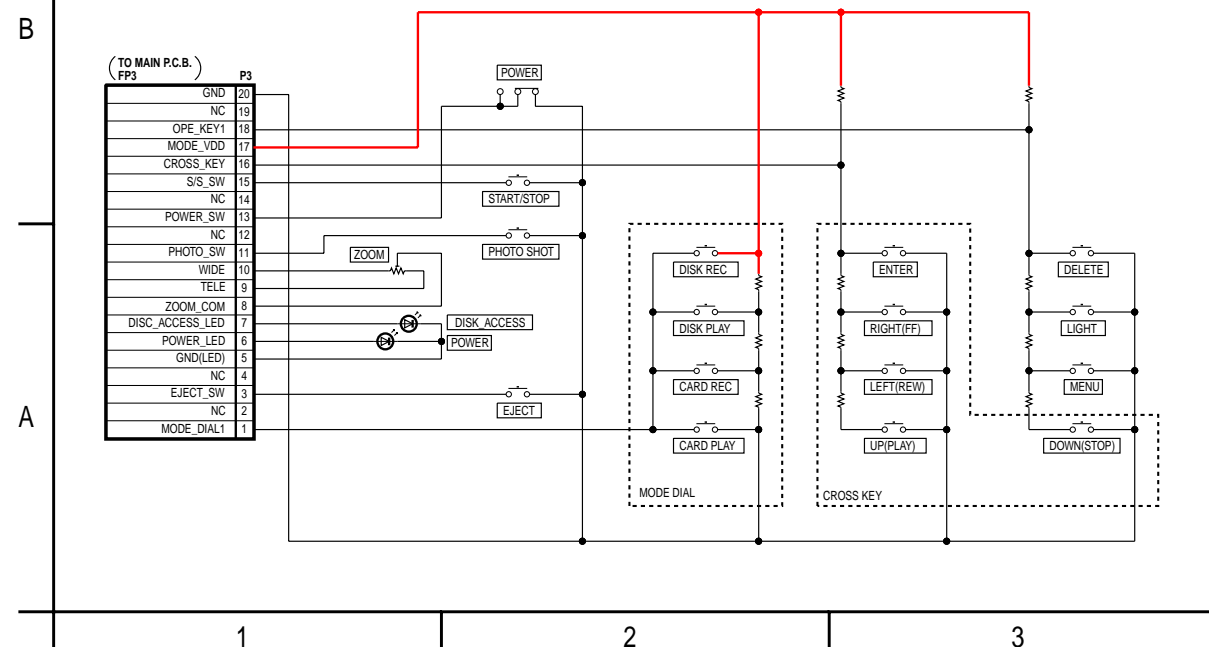

CCD SCHEMATIC DIAGRAM
LCD SW SCHEMATIC DIAGRAM
SIDE L / DISK SCHEMATIC DIAGRAM
VDR-D100EG/VDR-D100EB/VDR-D150E/VDR-D150EB/VDR-D150EF/VDR-D150EG/VDR-D150EP/VDR-D150EE
/VDR-D150GC/VDR-D150GN/VDR-D150GCS/VDR-D150SG/VDR-D152EG/VDR-D158GK

12.7. INTERCONNECTION SCHEMATIC DIAGRAM

INTERCONNECTION SCHEMATIC DIAGRAM

NOTE: For placing a purchase order of the parts, be sure to use the part number listed in the parts list. Do not use the part number on this diagram.

NOTE: PARTS MARKED "PT" ARE NOT USED.

NOTE: FOR SCHEMATIC DIAGRAM AND CIRCUIT BOARD LAYOUT NOTES, REFER TO BEGINNING OF SCHEMATIC SECTION.

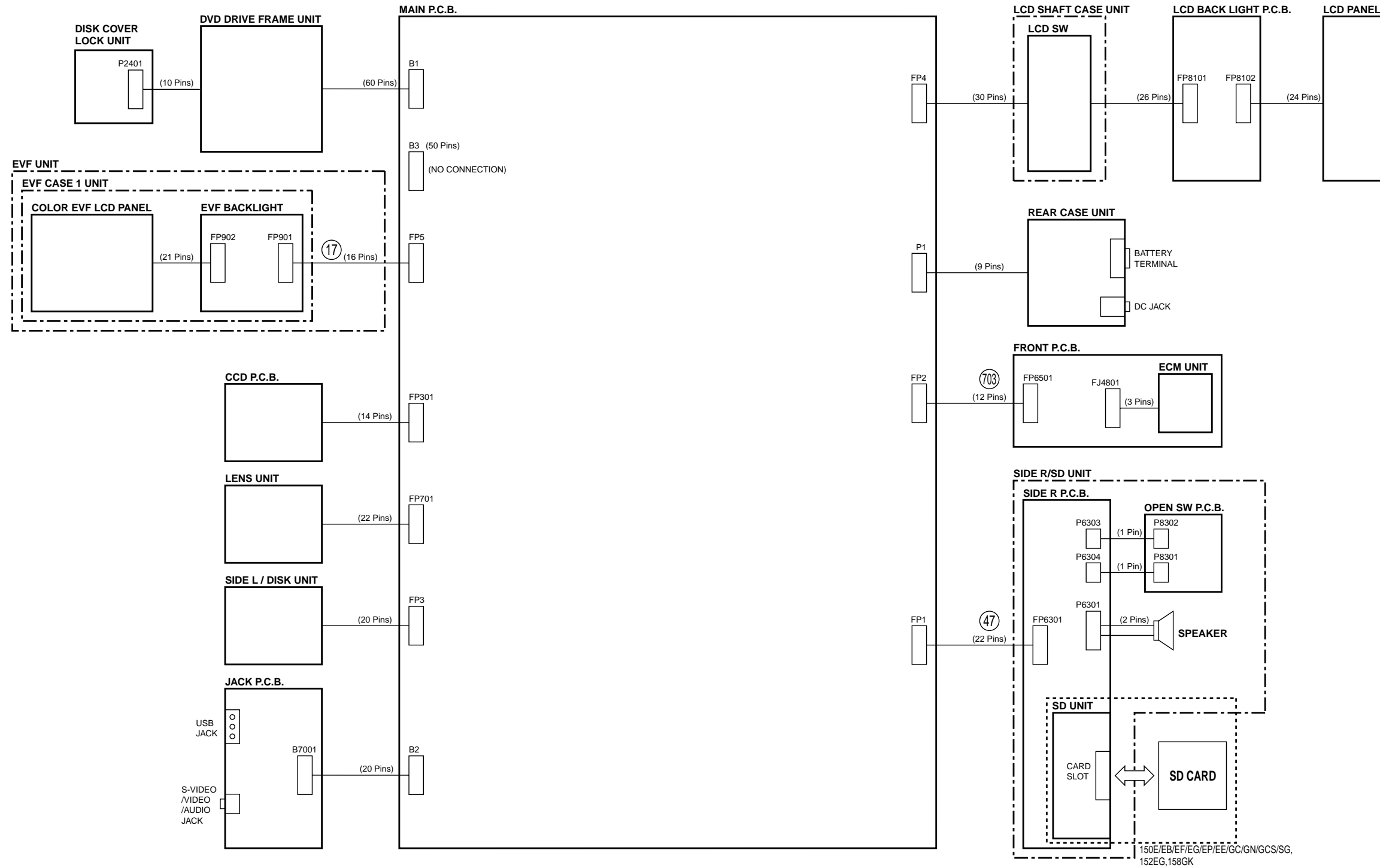

INTERCONNECTION SCHEMATIC DIAGRAM
 VDR-D100EG/VDR-D100EB/VDR-D150E/VDR-D150EB/VDR-D150EF/VDR-D150EG/VDR-D150EP/VDR-D150EE
 /VDR-D150GC/VDR-D150GN/VDR-D150GCS/VDR-D150SG/VDR-D152EG/VDR-D158GK

13 Printed Circuit Board

13.1. FRONT P.C.B.

FRONT P.C.B. LSEP8316A1 VDR-D100EG/EB

LSEP8316C1 VDR-D150E/EB/EF/EG/EP/EE/GC/GN/GCS/SG, VDR-D152EG, VDR-D158GK

NOTE:
FOR SCHEMATIC DIAGRAM AND CIRCUIT BOARD LAYOUT NOTES,
REFER TO BEGINNING OF SCHEMATIC SECTION.

NOTE:
CIRCUIT BOARD LAYOUT SHOWS COMPONENTS INSTALLED FOR VARIOUS MODELS.
FOR PROPER PARTS CONTENT FOR THE MODEL YOU ARE SERVICING,
PLEASE REFER TO THE SCHEMATIC DIAGRAM AND PARTS LIST.

NOTE:
CIRCUIT BOARD LAYOUT INCLUDES COMPONENTS WHICH ARE NOT USED.

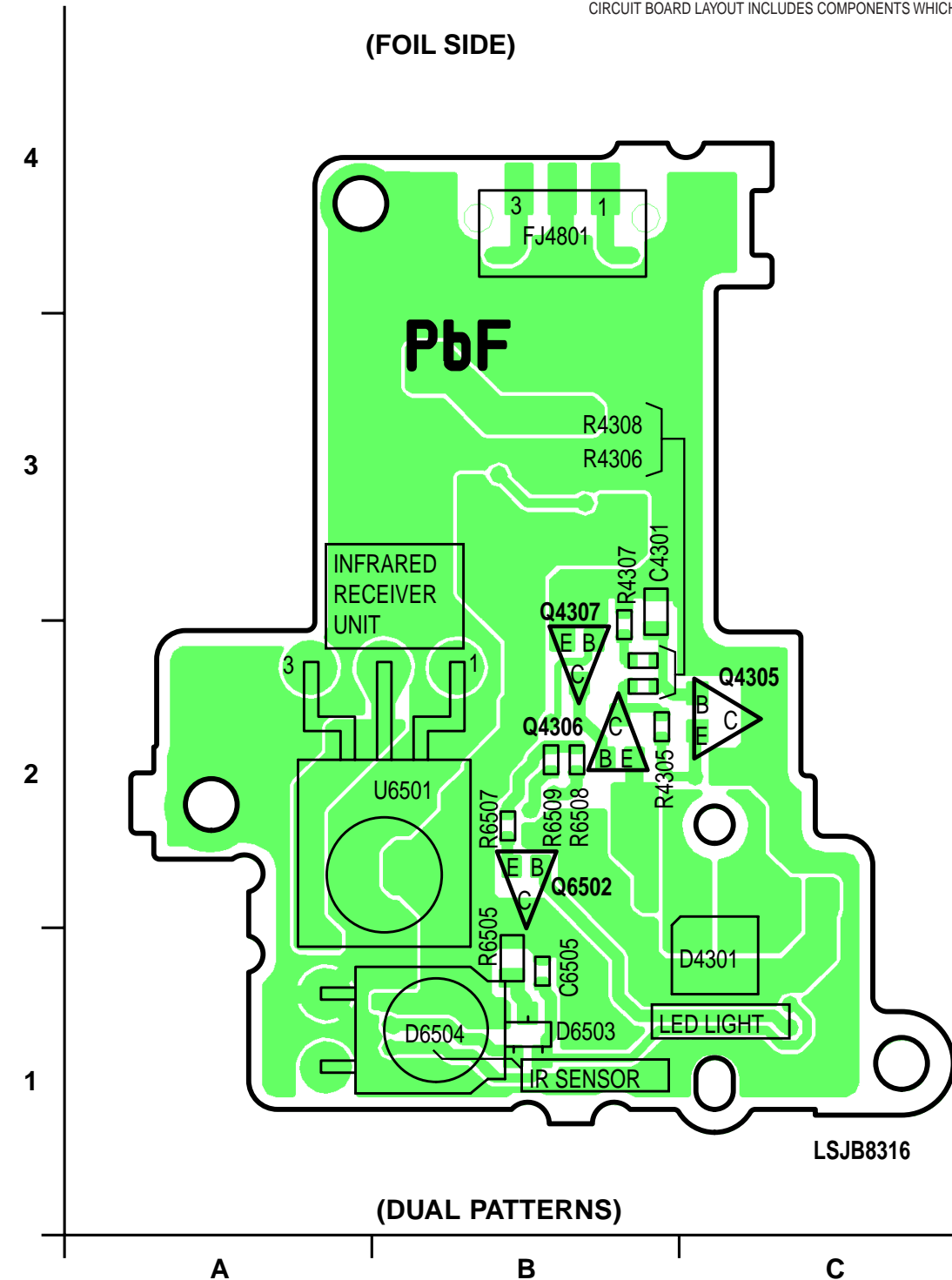
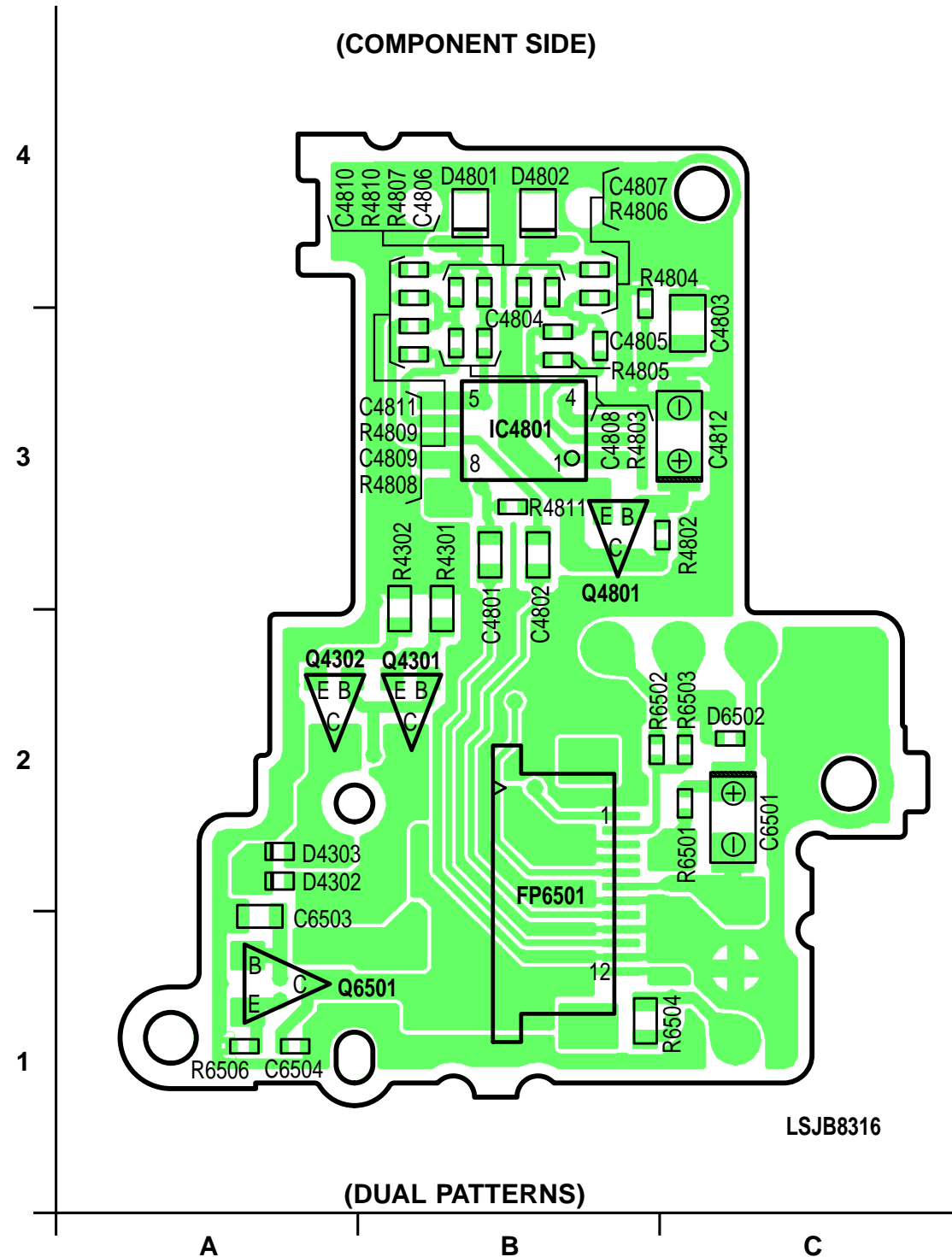

Parts Location

Front P.C.B.					
Integrated Circuit			Resistors		
IC4801	B-3	C	R4305	B-2	F
Transistors			R4306	B-3	F
Q4801	B-3	C	R4307	B-3	F
Q6501	A-1	C	R4308	B-3	F
Q6502	B-2	F	R4802	C-3	C
Connector			R4803	B-3	C
FP6501	B-2	C	R4804	B-4	C
Diodes			R4809	B-3	C
D6503	B-1	F	R4810	B-4	C
D6504	B-1	F	R6501	C-2	C
Capacitors			R6502	C-2	C
C4801	B-3	C	R6503	C-2	C
C4802	B-3	C	R6504	C-1	C
C4803	C-3	C	R6505	B-1	F
C4804	B-3	C	R6506	A-1	C
C4805	B-3	C	R6507	B-2	F
C4806	B-4	C	R6508	B-2	F
C4808	B-3	C	R6509	B-2	F
C4809	B-3	C	Miscellaneous		
C4810	A-4	C	U6501	B-2	F
C4812	C-3	C			
C6501	C-2	C			
C6503	A-1	C			
C6504	A-1	C			
C6505	B-1	F			

FRONT P.C.B.
LSEP8316A1/LSEP8316C1
VDR-D100EG/VDR-D100EB/VDR-D150E/VDR-D150EB/VDR-D150EF/VDR-D150EG/VDR-D150EP/VDR-D150EE
/VDR-D150GC/VDR-D150GN/VDR-D150GCS/VDR-D150SG/VDR-D152EG/VDR-D158GK

13.2. JACK P.C.B.

JACK P.C.B. LSEP8317A1

NOTE:
CIRCUIT BOARD LAYOUT SHOWS COMPONENTS INSTALLED FOR VARIOUS MODELS.
FOR PROPER PARTS CONTENT FOR THE MODEL YOU ARE SERVICING,
PLEASE REFER TO THE SCHEMATIC DIAGRAM AND PARTS LIST.

NOTE:
FOR SCHEMATIC DIAGRAM AND CIRCUIT BOARD LAYOUT NOTES,
REFER TO BEGINNING OF SCHEMATIC SECTION.

NOTE:
CIRCUIT BOARD LAYOUT INCLUDES COMPONENTS WHICH ARE NOT USED.

(COMPONENT SIDE)

(FOIL SIDE)

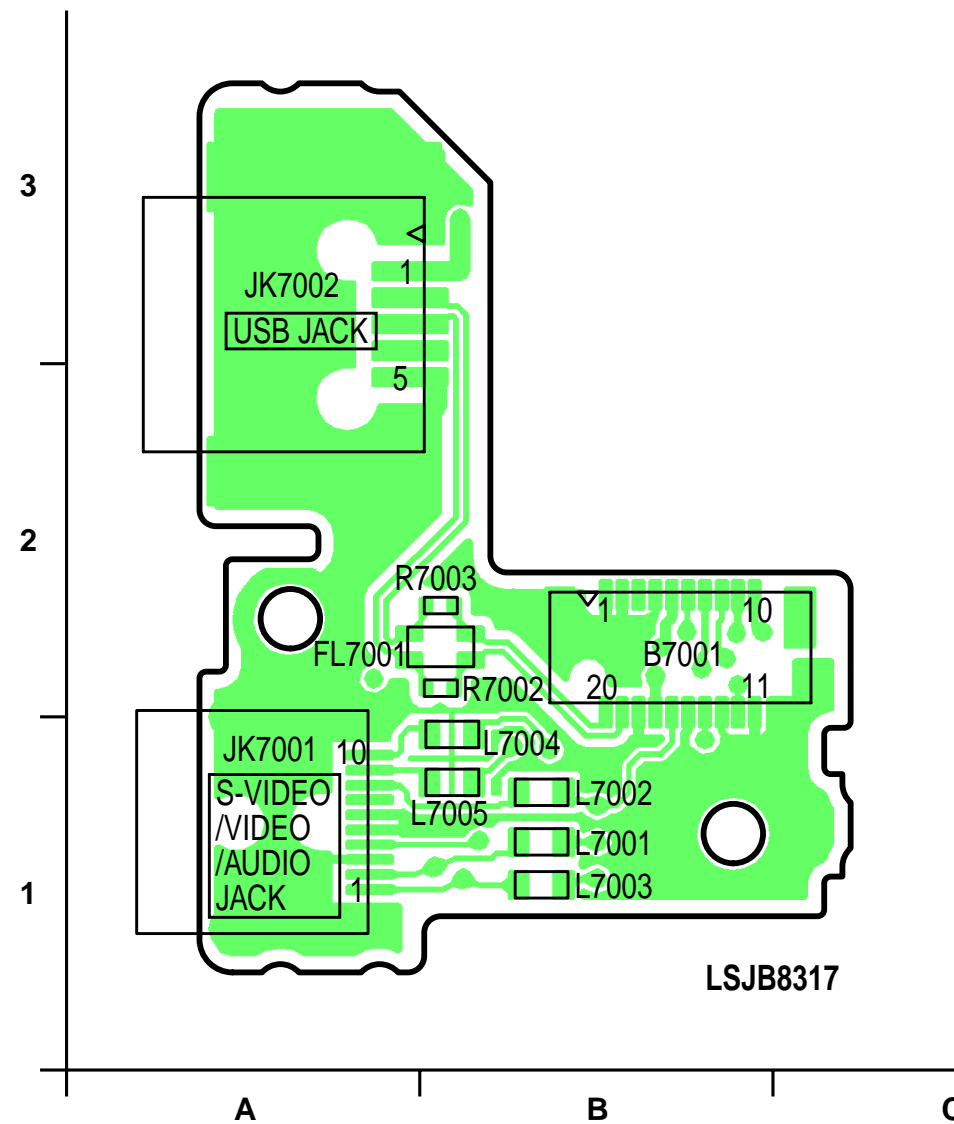
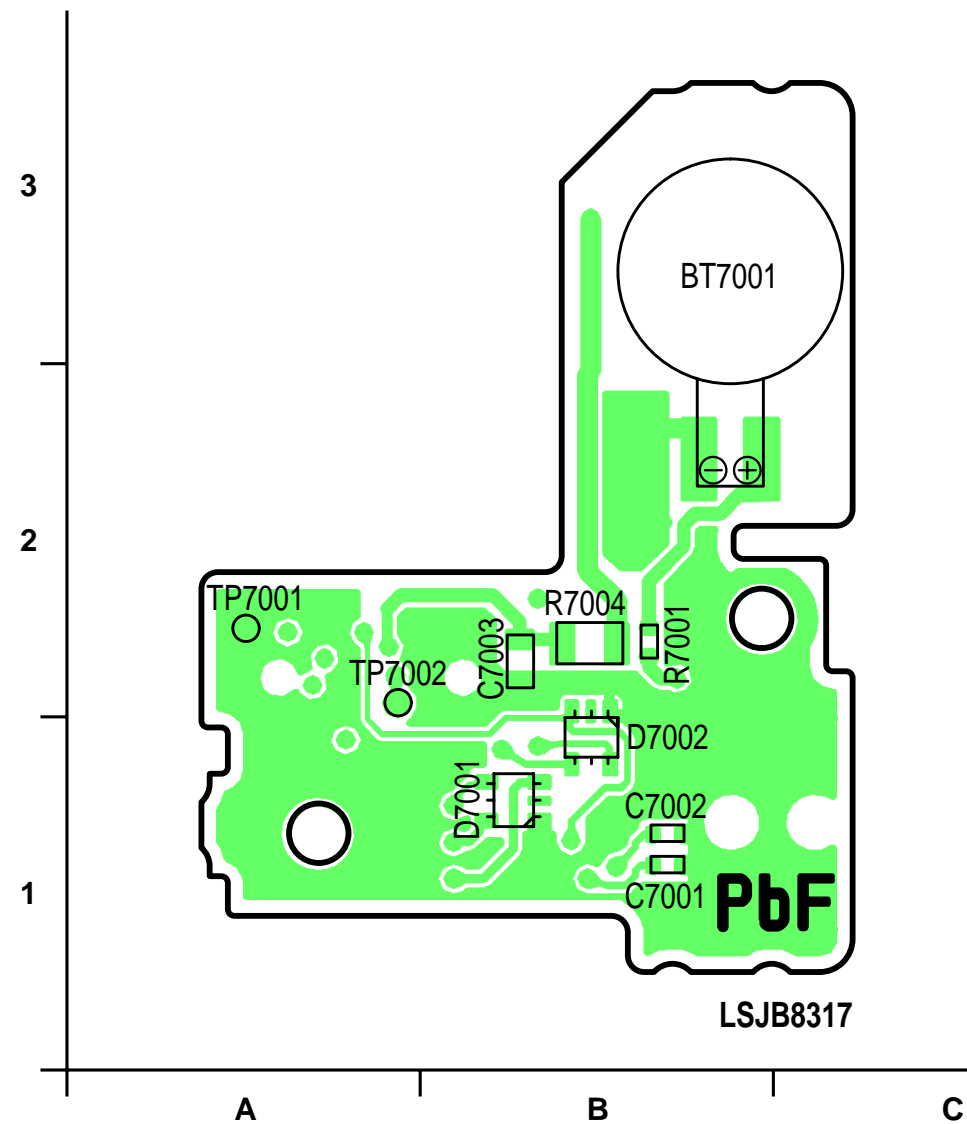

Parts Location

JACK P.C.B.		
Diodes		
D7001	B-1	C
D7002	B-1	C
Coilss		
L7001	B-1	F
L7002	B-1	F
L7003	B-1	F
L7004	B-1	F
L7005	B-1	F
Capacitors		
C7001	B-1	C
C7002	B-1	C
C7003	B-2	C
Resistors		
R7001	B-2	C
R7002	B-2	F
R7003	B-2	F
R7004	B-2	C
Miscellaneous		
B7001	B-2	F
BT7001	B-3	C
JK7001	A-1	F
JK7002	A-3	F

(DUAL PATTERNS)

(DUAL PATTERNS)

JACK P.C.B. LSEP8317A1

VDR-D100EG/VDR-D100EB/VDR-D150E/VDR-D150EB/VDR-D150EF/VDR-D150EG/VDR-D150EP/VDR-D150EE
/VDR-D150GC/VDR-D150GN/VDR-D150GCS/VDR-D150SG/VDR-D152EG/VDR-D158GK

13.3. LCD BACKLIGHT P.C.B.

LCD BACKLIGHT P.C.B. LSEP8318A1

NOTE:
CIRCUIT BOARD LAYOUT SHOWS COMPONENTS INSTALLED FOR VARIOUS MODELS.
FOR PROPER PARTS CONTENT FOR THE MODEL YOU ARE SERVICING,
PLEASE REFER TO THE SCHEMATIC DIAGRAM AND PARTS LIST.

NOTE:
CIRCUIT BOARD LAYOUT INCLUDES COMPONENTS WHICH ARE NOT USED.

NOTE:
ALL INDIVIDUAL PARTS EXCEPT D8101, D8103, D8105, AND D8107
ON LCD BACKLIGHT P.C.B. ARE SUPPLIED AS REPLACEMENT PARTS.
WHEN SERVICING THESE PARTS, REPLACE LCD BACKLIGHT P.C.B.
INSTEAD OF INDIVIDUAL PARTS.

NOTE:
FOR SCHEMATIC DIAGRAM AND CIRCUIT BOARD LAYOUT NOTES,
REFER TO BEGINNING OF SCHEMATIC SECTION.

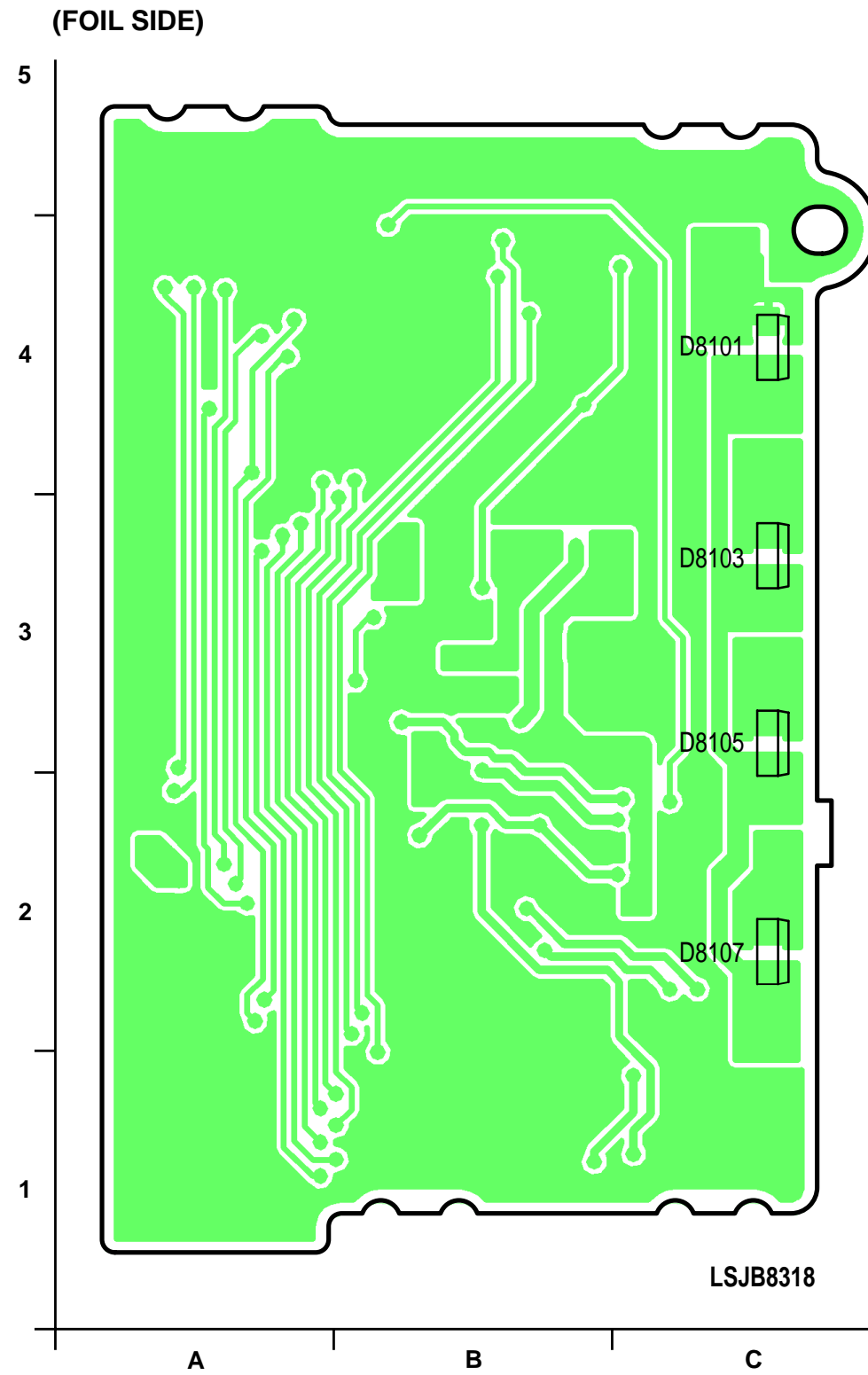
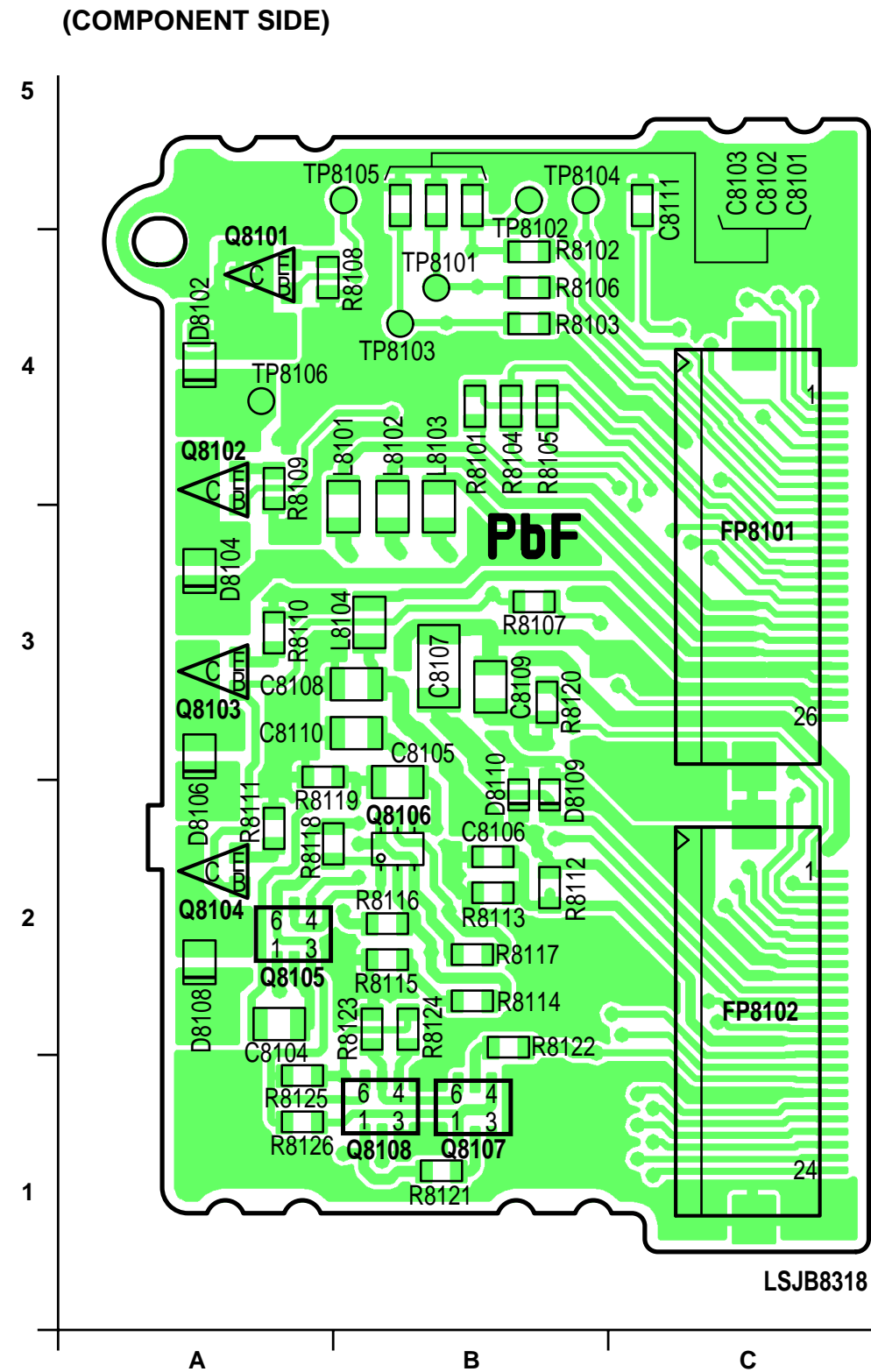

Parts Location

LCD P.C.B.					
Transistors			C8107	B-3	C
Q8101	A-4	C	C8108	A-3	C
Q8102	A-4	C	C8109	B-3	C
Q8103	A-3	C	C8110	A-3	C
Q8104	A-2	C	Resistors		
Q8105	A-2	C	R8101	B-4	C
Q8106	B-2	C	R8102	B-4	C
Connectors			R8103	B-4	C
FP8101	C-3	C	R8104	B-4	C
FP8102	C-2	C	R8105	B-4	C
Diodes			R8106	B-4	C
D8109	B-2	C	R8107	B-3	C
D8110	B-2	C	R8108	B-4	C
Coils			R8109	A-4	C
L8101	B-4	C	R8110	A-3	C
L8102	B-4	C	R8111	A-2	C
L8103	B-4	C	R8112	B-2	C
L8104	B-3	C	R8113	B-2	C
Capacitors			R8114	B-2	C
C8101	C-5	C	R8115	B-2	C
C8102	C-5	C	R8116	B-2	C
C8103	C-5	C	R8117	B-2	C
C8104	A-2	C	R8118	A-2	C
C8105	B-3	C	R8119	A-2	C
C8106	B-2	C	R8120	B-3	C

(DUAL PATTERNS)

(DUAL PATTERNS)

LCD BACKLIGHT P.C.B. LSEP8318A1

VDR-D100EG/VDR-D100EB/VDR-D150E/VDR-D150EB/VDR-D150EF/VDR-D150EG/VDR-D150EP/VDR-D150EE
/VDR-D150GC/VDR-D150GN/VDR-D150GCS/VDR-D150SG/VDR-D152EG/VDR-D158GK

13.4. SIDE R P.C.B. / OPEN SWITCH P.C.B.

SIDE R P.C.B. LSEP8339A1 VDR-D100EG/EB
 LSEP8339B1 VDR-D150E/EB/EF/EG/EP/EE/GC/GN/GCS/SG,VDR-D152EG,VDR-D158GK

NOTE:
 FOR SCHEMATIC DIAGRAM AND CIRCUIT BOARD LAYOUT NOTES,
 REFER TO BEGINNING OF SCHEMATIC SECTION.

NOTE:
 CIRCUIT BOARD LAYOUT SHOWS COMPONENTS INSTALLED FOR VARIOUS MODELS.
 FOR PROPER PARTS CONTENT FOR THE MODEL YOU ARE SERVICING,
 PLEASE REFER TO THE SCHEMATIC DIAGRAM AND PARTS LIST.

NOTE:
 CIRCUIT BOARD LAYOUT INCLUDES COMPONENTS WHICH ARE NOT USED.

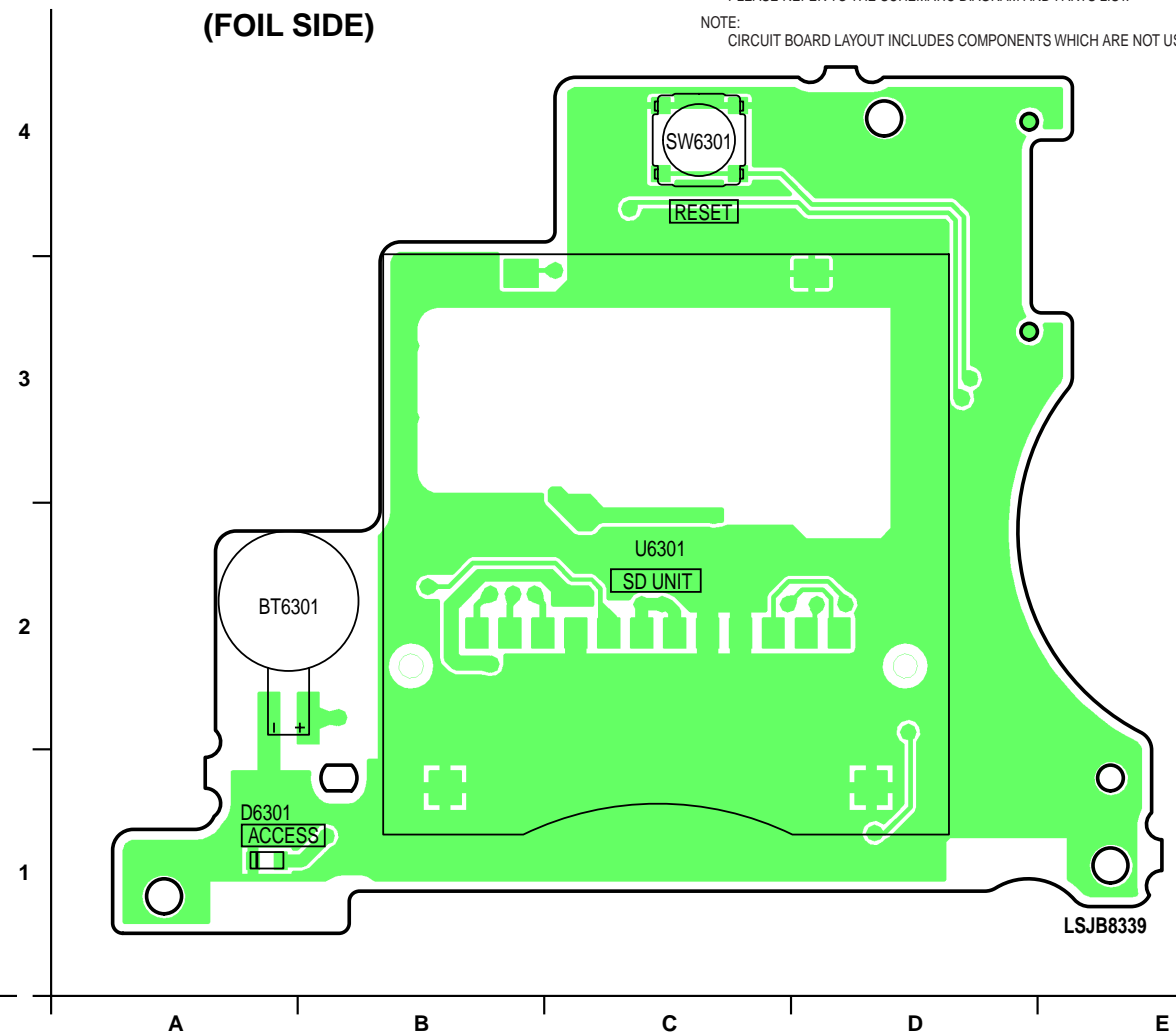
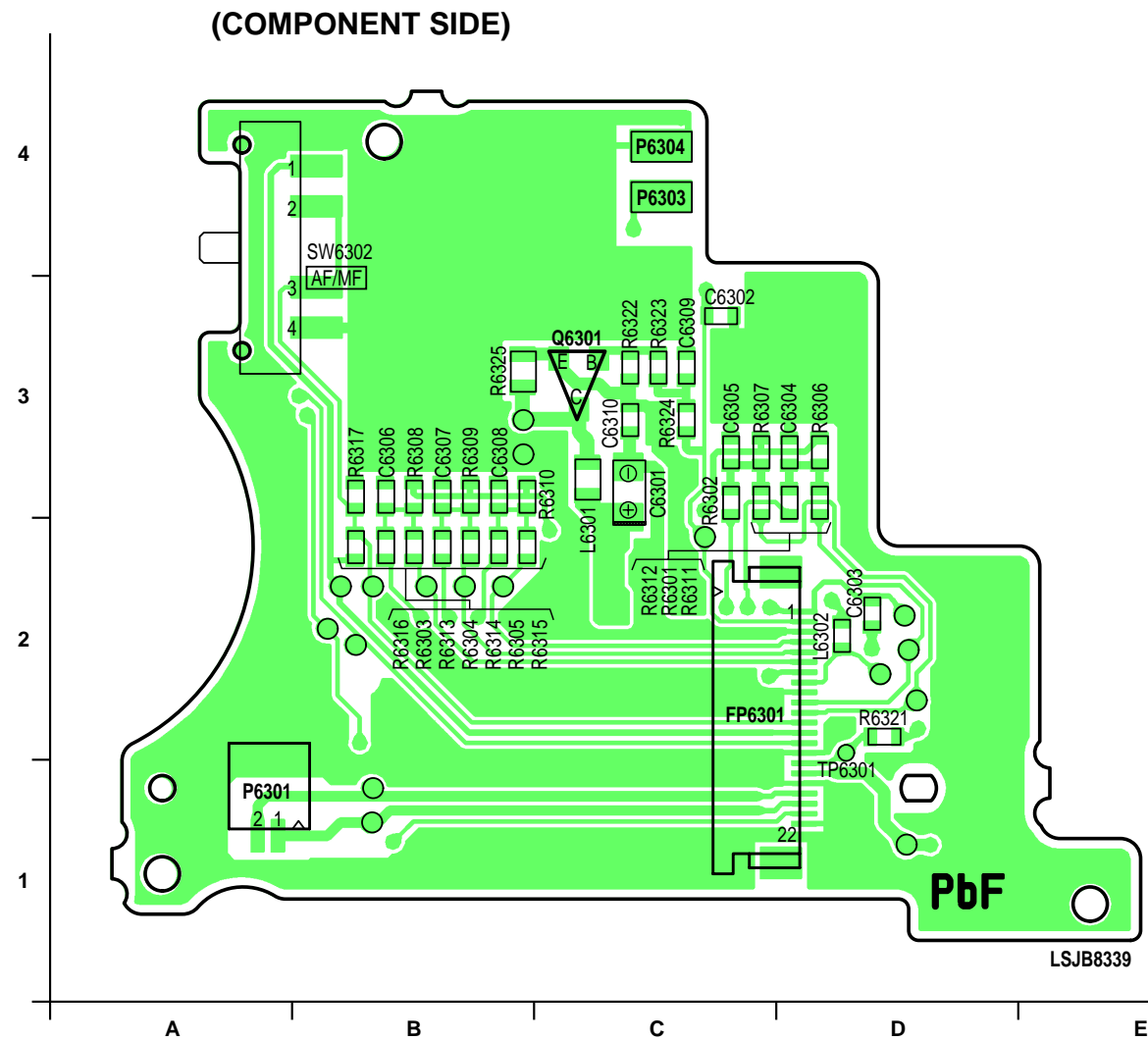

Parts Location

SIDE-R P.C.B.					
Transistor			Resistors		
Q6301	C-3	C	R6301	C-2	C
Connectors			R6302	C-3	C
FP6301	C-2	C	R6303	B-2	C
P6301	A-1	C	R6304	B-2	C
Diode			R6305	B-2	C
D6301	A-1	F	R6306	D-3	C
Coils			R6307	C-3	C
L6301	C-2	C	R6308	B-3	C
L6302	D-2	C	R6309	B-3	C
Switches			R6310	C-3	C
SW6301	C-4	F	R6311	C-2	C
SW6302	B-4	C	R6312	C-2	C
Capacitors			R6313	B-2	C
C6301	C-3	C	R6314	B-2	C
C6302	C-3	C	R6315	C-2	C
C6303	D-2	C	R6316	B-2	C
C6304	D-3	C	R6317	B-3	C
C6305	C-3	C	R6323	C-3	C
C6306	B-3	C	R6324	C-3	C
C6307	B-3	C	R6325	B-3	C
C6308	B-3	C	Miscellaneous		
C6310	C-3	C	U6301	C-2	F

OPEN SWITCH P.C.B. LSEP8340A1

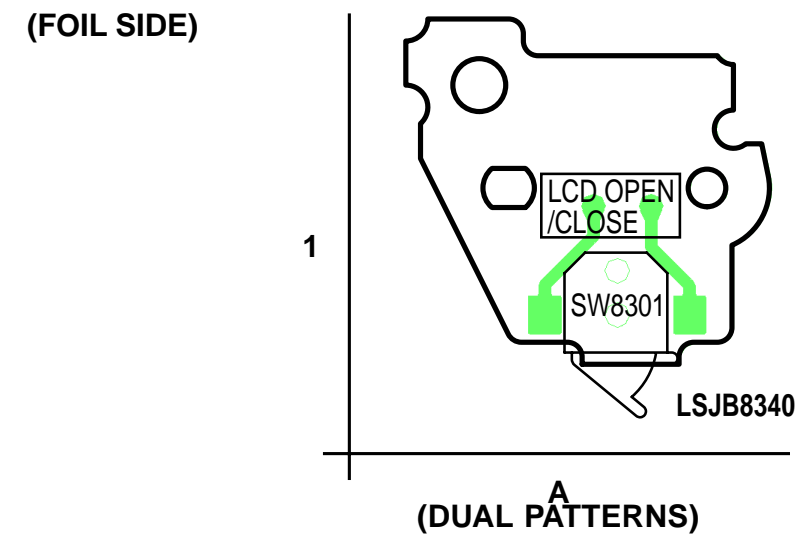
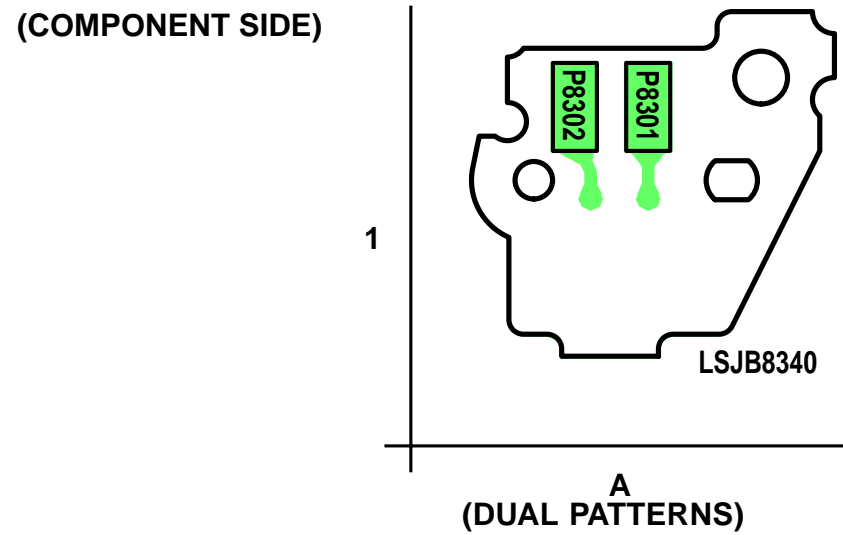

SIDE R P.C.B. LSEP8339A1/LSEP8339B1
 OPEN SWITCH P.C.B. LSEP8340A1
 VDR-D100EG/VDR-D100EB/VDR-D150E/VDR-D150EB/VDR-D150EF/VDR-D150EG/VDR-D150EP/VDR-D150EE
 /VDR-D150GC/VDR-D150GN/VDR-D150GCS/VDR-D150SG/VDR-D152EG/VDR-D158GK

14.2. FRONT CASE, MAIN P.C.B. AND JACK P.C.B. SECTION

② FRONT CASE, MAIN P.C.B. AND JACK P.C.B. SECTION

Note:

1. Parts with no Ref. No. in "EXPLODED VIEW" are not supplied. And some Ref. No. will be skipped. Be sure to make your orders of replacement parts according to the parts list.
2. The parts indicated by the dotted line  are for Ass'y only and are not supplied.
3. Disregard Ref. No. suffixes when ordering parts. They are used to describe parts in "Disassembly and Assembly Instructions" section.

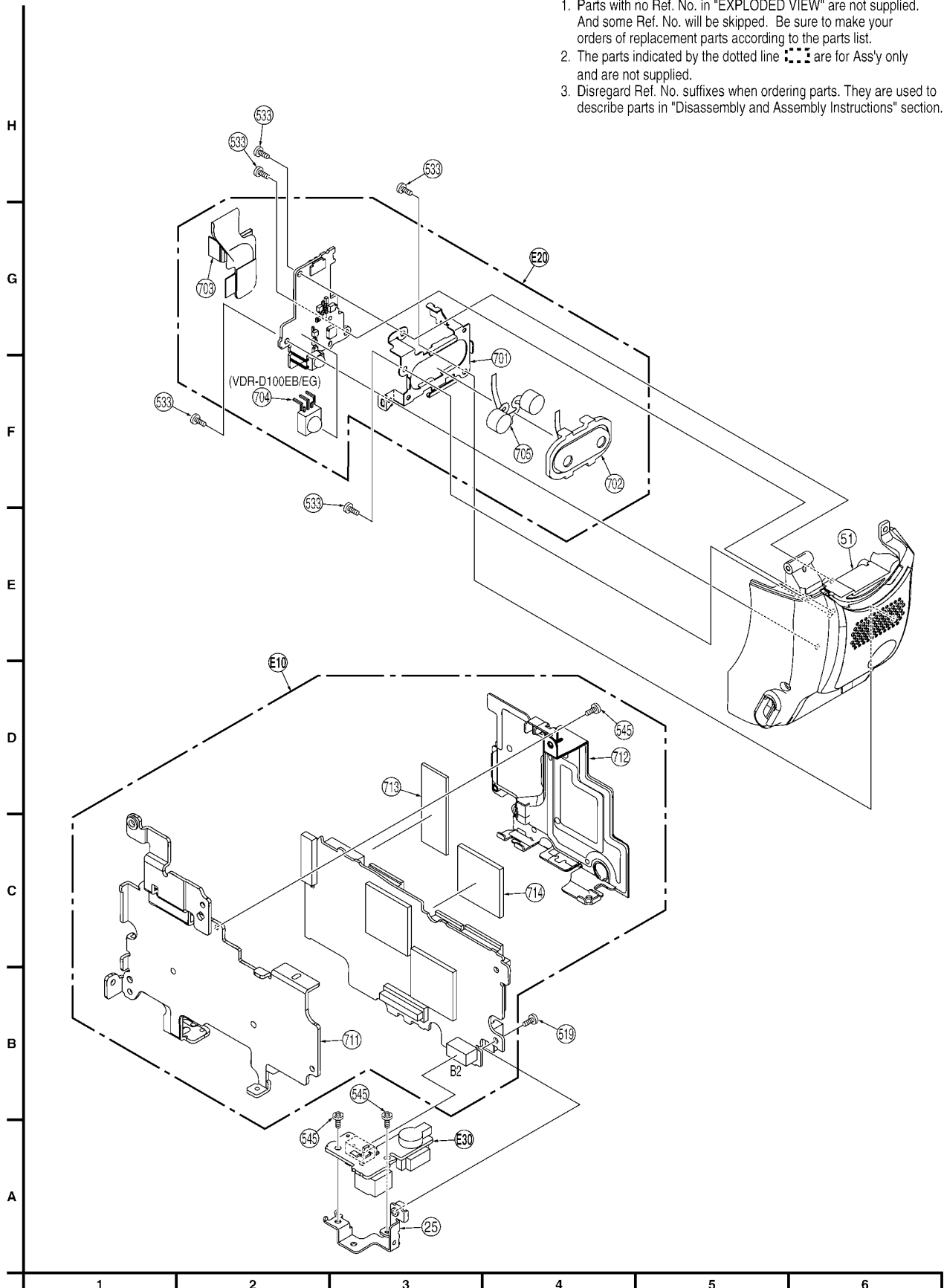

14.4. CCD AND LENS SECTION



4 CCD AND LENS SECTION

Note:

1. Parts with no Ref. No. in "EXPLODED VIEW" are not supplied. And some Ref. No. will be skipped. Be sure to make your orders of replacement parts according to the parts list.
2. The parts indicated by the dotted line  are for Assy only and are not supplied.
3. Disregard Ref. No. suffixes when ordering parts. They are used to describe parts in "Disassembly and Assembly Instructions" section.

LUBRICATION POINTS

When the marked parts are replaced, apply the recommended lubricants or adhesive for better maintenance of the unit.

Mark	Kind of Lubricant	Availability	Part Number
 	Grease	Available from Factory	LSUQ0050

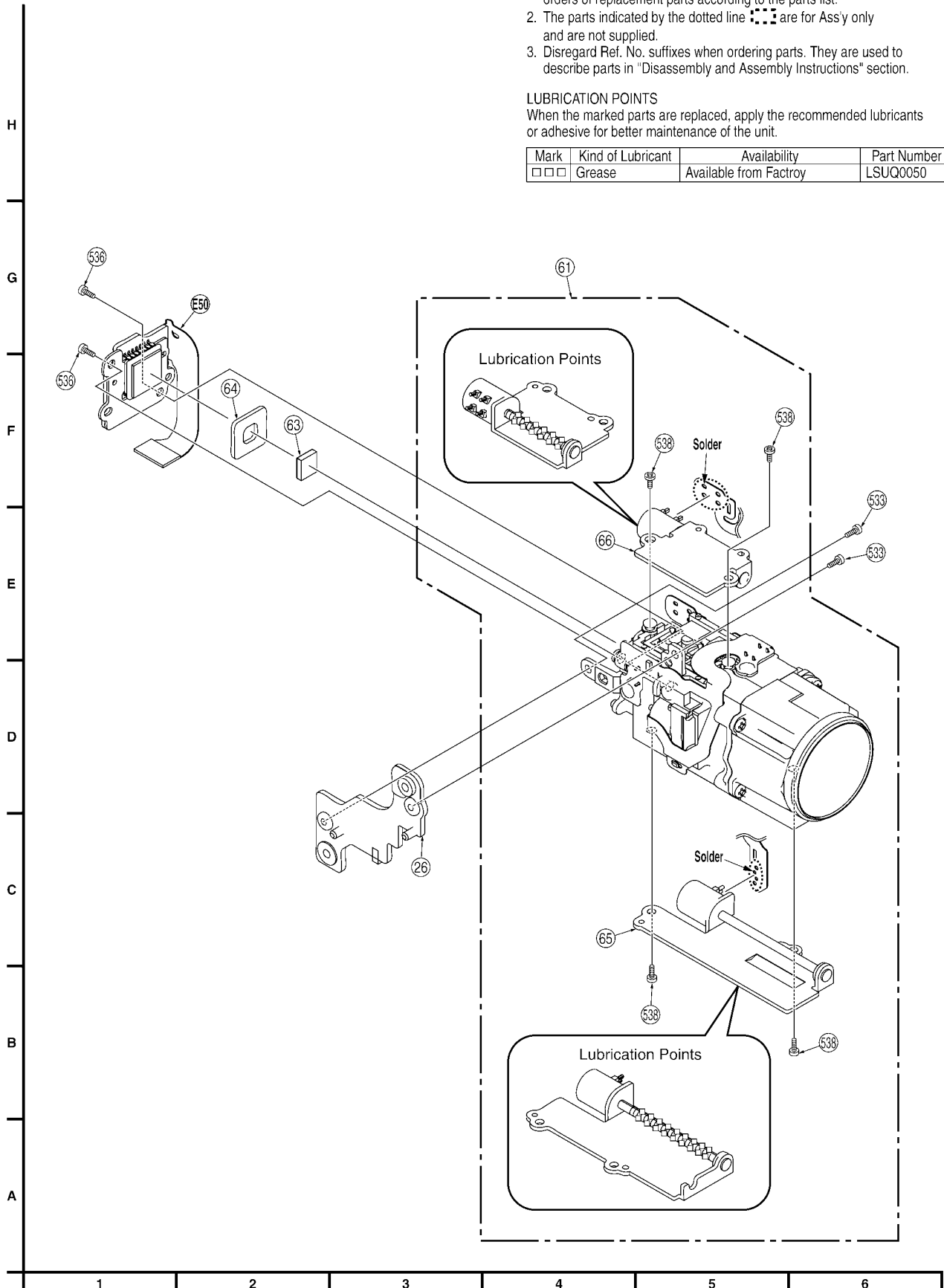

14.5. REAR CASE AND EVF SECTION

5 REAR CASE AND EVF SECTION

Note:

1. Parts with no Ref. No. in "EXPLODED VIEW" are not supplied. And some Ref. No. will be skipped. Be sure to make your orders of replacement parts according to the parts list.
2. The parts indicated by the dotted line  are for Ass'y only and are not supplied.
3. Disregard Ref. No. suffixes when ordering parts. They are used to describe parts in 'Disassembly and Assembly Instructions' section.

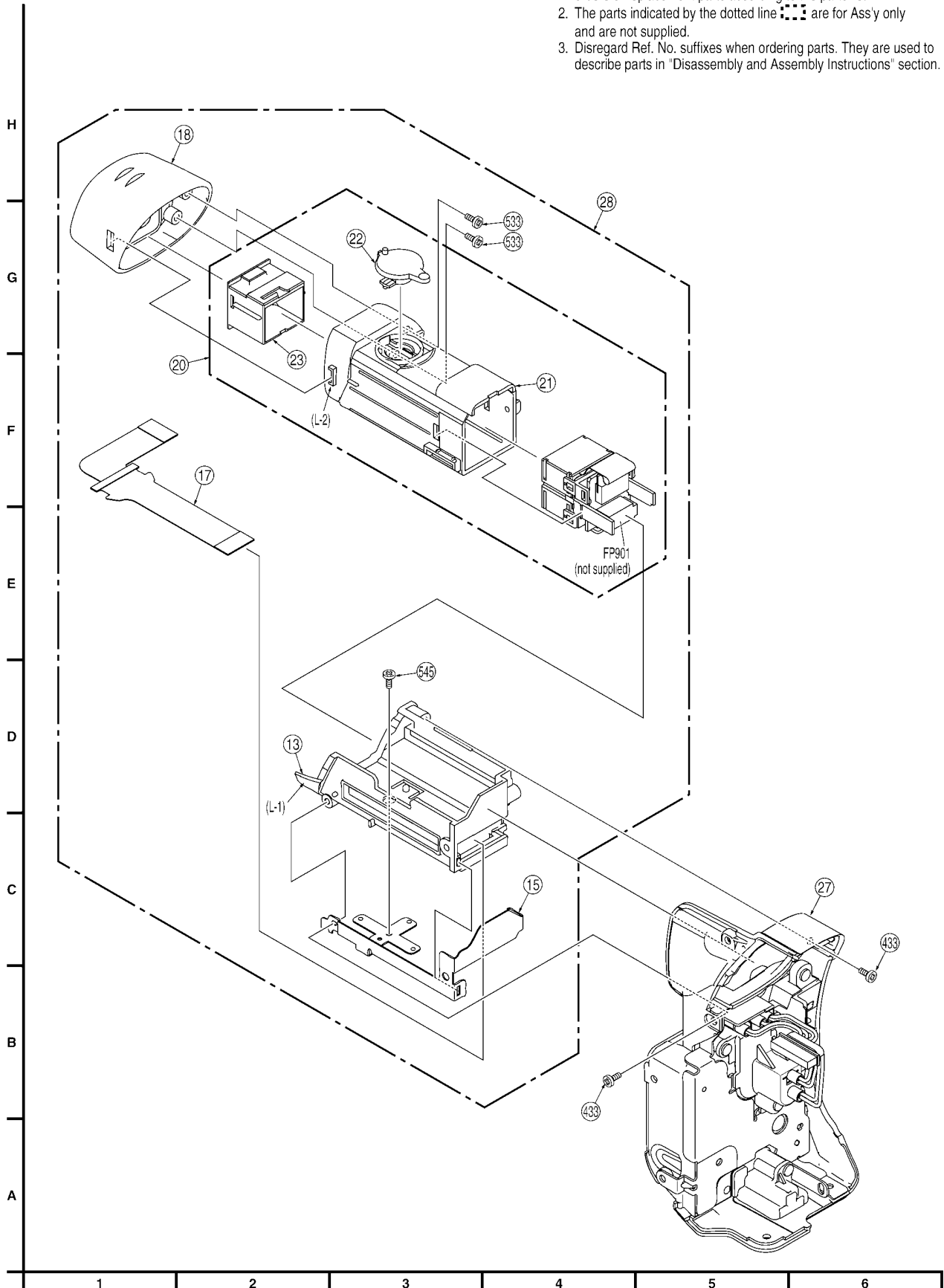

14.6. PACKING PARTS AND ACCESSORIES SECTION

6 PACKING PARTS AND ACCESSORIES SECTION

IMPORTANT SAFTY NOTICE:

COMPONENTS IDENTIFIED BY THE SIGN  HAVE SPECIAL CHARACTERISTICS IMPORTANT FOR SAFETY. WHEN REPLACING ANY OF THESE COMPONENTS, USE ONLY THE SPECIFIED PARTS.

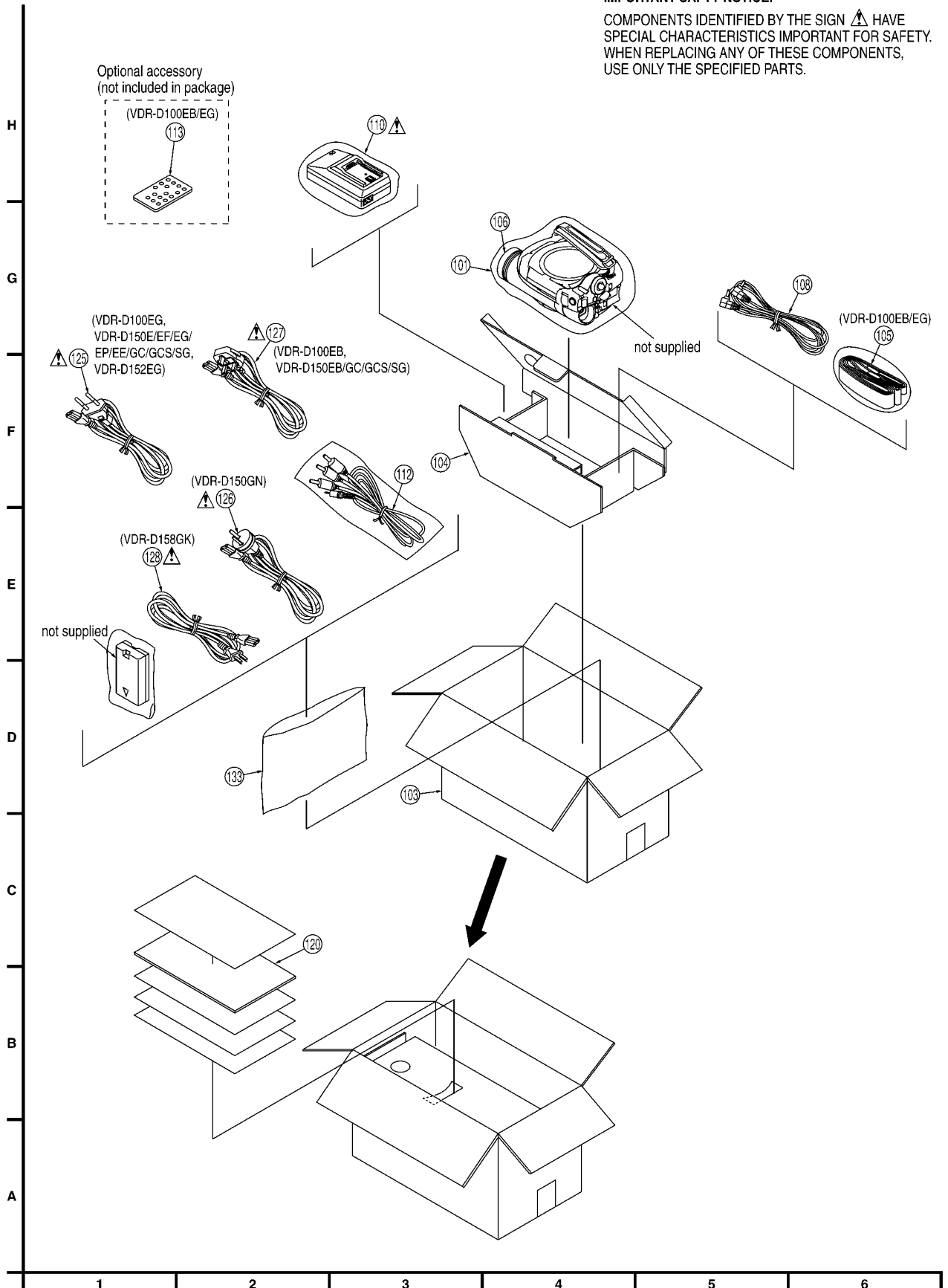

15 Replacement Parts Lists

BEFORE REPLACING PARTS, READ THE FOLLOWING:

1. Use only original replacement parts:

To maintain original function and reliability of repaired units, use only original replacement parts which are listed with their part numbers in the parts list.

2. IMPORTANT SAFETY NOTICE

Components identified by the sign \triangle have special characteristics important for safety. When replacing any of these components, use only the specified parts.

3. Definition of Parts supplier:

a. Parts with mark "SPC" in the Remarks column are supplied from Spare Parts Center of Panasonic AVC Company.

b. Parts without mark in the Remarks column are supplied from PSEC.

4. Parts whose Ref. Nos. are the same are interchangeable as replacement parts. Any of these parts may be ordered and used as a replacement part.

5. Model Number Indication:

Model numbers are indicated in the Remarks column without "VDR-D"

6. Unless otherwise specified;

All resistors are in Ω , K = 1,000 Ω , M = 1,000 k Ω .

7. Abbreviation

RTL: Retention Time Limited

This indicates that the retention time is limited for this item. After the discontinuation of this item in production, it will no longer be available.

NR: Non Repairable Board Ass'y

MGF CHIP: Metal Glaze Film Chip

C CHIP: Ceramic Chip

COMPLX CMP: Complex Component

W FLMPRF: Wirewound Flameproof

P.C.B.: Circuit Board Assembly

P.C.B.: Printed Circuit Board

E.S.D.: Electrostatically Sensitive Devices

CSP: Chip Size Package

8. AC Adaptor replacement note

a. VSK0561 is indicated on the AC Adaptor used in the following model:

VDR-D158GK.

However, the AC Adaptor replacement part number is DE-974HA which should be used when ordering.

b. VSK0561 is indicated on AC Adaptor used in the following models:

VDR-D100EB, VDR-D100EG, VDR-D150E, VDR-D150EB, VDR-D150EE, VDR-D150EF, VDR-D150EG, VDR-D150EP, VDR-D150GC, VDR-D150GCS, VDR-D150GN, VDR-D150SG, and VDR-D152EG.

However, the AC Adaptor replacement part number is DE-974GB which should be used when ordering.

15.1. MECHANICAL REPLACEMENT PARTS LIST

Definition of Parts supplier:

1. Parts with mark "SPC" in the Remarks column are supplied from Spare Parts Center of Panasonic AVC Company.

2. Parts without mark in the Remarks column are supplied from PSEC.

MECHANICAL REPLACEMENT PARTS

Ref. No.	Part No.	Part Name & Description	Remarks
1	LSYK1817	SIDE L/DISK UNIT	100EB/EG
1	LSYK1803	SIDE L/DISK UNIT	150E/EB/EF/EG/EP/EE/GC/GN/GCS/SG,152EG,158GK
2	LMXK1931S-2	DVD DRIVE FRAME UNIT	\triangle 100EB/EG,150E/EB/EF/EG/EP/GC,152EG
2	LMXK1931S-5	DVD DRIVE FRAME UNIT	\triangle 150EE
2	LMXK1931S-4	DVD DRIVE FRAME UNIT	\triangle 150GN
2	LMXK1931S-3	DVD DRIVE FRAME UNIT	\triangle 150GCS/SG
2	LMXK1931S-6	DVD DRIVE FRAME UNIT	\triangle 158GK
3	LSXY1001	DISK COVER LOCK UNIT	\triangle
4	LSYK1638	TOP COVER UNIT	
5	LSKF0649	EVR COVER	
7	LSYK1620	BOTTOM ANGLE UNIT	
8	LSSC0895	HEAT CONDUCT SHEET	
13	LSKM1133	EVF BASE FRAME	
15	LSSC0824	EVF EARTH PLATE	
17	LSJB8323	C-EVF FPC	
18	LSGQ0172	EYE CAP	
20	LSYK1624	EVF CASE 1 UNIT,ABS RESIN	
21	LSKM1132	EVF CASE,ABS RESIN	
22	LSGT0611	EYE SIGHT LEVER	
23	LSYK1626	EVF LENS UNIT	
25	LSSC0823	JACK ANGLE	
26	LSMD0818	LENS HOLDER	
27	LSYK1621	REAR CASE UNIT,ABS RESIN	
28	LSYK1622	EVF UNIT	RTL
31	LSYK1648	SIDE CASE R UNIT,ABS RESIN	100EB/EG
31	LSYK1631	SIDE CASE R UNIT,ABS RESIN	150E/EB/EF/EG/EP/EE/GC/GN/GCS/SG,152EG,158GK
32	LSYK1634	LCD SHAFT CASE UNIT,ABS RESIN	
33	LSYK1757	LCD CASE A UNIT,ABS RESIN	100EB/EG
33	LSYK1805	LCD CASE A UNIT,ABS RESIN	150E/EB/EF/EG/EP/EE/GC/GN/GCS/SG
33	LSYK1834	LCD CASE A UNIT,ABS RESIN	152EG
33	LSYK1806	LCD CASE A UNIT,ABS RESIN	158GK
34	LSKM1134	LCD CASE B,ABS RESIN	

Ref. No.	Part No.	Part Name & Description	Remarks
35	LSXY0933	LCD SHIELD PLATE UNIT	
36	LSXY0934	LCD PANEL HOLDER UNIT	
37	LSGL0422	LEAD LIGHT PANEL	
38	LSGL0404	DIFFUSION SHEET	
39	LSGL0423	REFLECT SHEET	
40	LSGL0406	BEF SHEET	
41	LSGL0421	BEF SHEET A	
42	L5BDDYH00014	LIQUID CRYSTAL DISPLAY PANEL	
45	L0AA02A00062	SPEAKER	
46	LSMC0136	SPEAKER SPRING PLATE	
47	LSJB8327	SIDE-R FPC	
48	LSMF0372	SHEET	
51	LSYK1662	FRONT CASE 1 UNIT,ABS RESIN	
61	LSXN0041	LENS UNIT	
63	VDL1390-B	OPTICAL LOW PASS FILTER	
64	VMX3282	FILTER RUBBER	
65	L6HA66NB0005	ZOOM MOTOR UNIT	
66	L6HA66NB0004	FOCUS MOTOR UNIT	
101	VPF1129	POLY BAG	
103	LSPG2115	PACKING CASE,PAPER	100EB/EG
103	LSPG2171	PACKING CASE,PAPER	150E/EB/EF/EG/EP
103	LSPG2172	PACKING CASE,PAPER	150EE/GC/GN/GCS/SG
103	LSPG2202	PACKING CASE,PAPER	152EG
103	LSPG2173	PACKING CASE,PAPER	158GK
104	LSPN0659	DVD PACKING	
105	VFC3506-1A	SHOULDER STRAP	100EB/EG
106	LSYF0552	LENS CAP UNIT	
108	K2GJ2DC00011	DC CABLE W/PLUG	
110	DE-974GB	AC ADAPTOR UNIT	△ 100EB/EG,150E/EB/EF/EG/EP/EE/GC/GN/GCS/SG,152EG
110	DE-974HA	AC ADAPTOR UNIT	△ 158GK
112	K2KZ9CB00001	AV CABLE W/PLUG	
113	N2QAEC000019	INFRARED REMOTE CONTROL UNIT	100EB/EG
120	LSQT1048-A	INSTRUCTION BOOK (ENGLISH)	100EB,150EB
120	LSQT0987-A	INSTRUCTION BOOK (GERMAN/SPANISH/ITALIAN)	100EG
120	LSQT1044-A	INSTRUCTION BOOK (PORTUGUESE/SPANISH)	150E
120	LSQT1045-A	INSTRUCTION BOOK (SWEDISH/DANISH)	150E
120	LSQT1043-A	INSTRUCTION BOOK (GERMAN/FRENCH)	150EF
120	LSQT1041-A	INSTRUCTION BOOK (GERMAN/FRENCH)	150EG,152EG
120	LSQT1042-A	INSTRUCTION BOOK (ITALIAN/DUTCH)	150EG,152EG
120	LSQT1046-A	INSTRUCTION BOOK (ENGLISH/POLISH)	150EP
120	LSQT1047-A	INSTRUCTION BOOK (CZECH/HANGARIAN)	150EP
120	LSQT1051-A	INSTRUCTION BOOK (RUSSIAN/UKRAINIAN)	150EE
120	LSQT1049-A	INSTRUCTION BOOK (ENGLISH/CHINESE TRADITIONAL)	150GC/GCS/SG
120	LSQT1050-A	INSTRUCTION BOOK (ARABIC/PERSIAN)	150GC/GCS/SG
120	LSQT1052-A	INSTRUCTION BOOK (ENGLISH)	150GN
120	LSQT1053-A	INSTRUCTION BOOK (CHINESE SIMPLIFIED)	158GK

Ref. No.	Part No.	Part Name & Description	Remarks
125	K2CR2DA00004	AC CORD W/PLUG	△ 100EG,150E/EF/EG/EP/EE/GC/GCS,152EG
125	K2CR2DA00006	AC CORD W/PLUG	△ 150SG
126	K2CJ2DA00011	AC CORD W/PLUG	△ 150GN
127	RJA0053-3X	AC CORD W/PLUG	△ 100EB,150EB/GC/GCS/SG
128	K2CA2CA00020	AC CORD W/PLUG	△ 158GK
133	LSPF0107	POLY BAG	
408	XQN2+BJ6FN	SCREW,STEEL	
419	XQN2+BJ5FN	SCREW,STEEL	
433	XQN16+BJ6FN	SCREW,STEEL	
457	XQN2+BF5FN	SCREW,STEEL	
519	XQN16+BF4FN	SCREW,STEEL	
533	XQN16+BJ4FN	SCREW,STEEL	
536	XQN16+AJ4FN	SCREW,STEEL	
538	XQN14+BJ4FN	SCREW,STEEL	
544	XQN16+BF2FN	SCREW,STEEL	
545	XQN16+BF25FN	SCREW,STEEL	
546	LSHD0088	SCREW,STEEL	
701	LSSC0827	FRONT EARTH PLATE A	
702	LSMG0136	MIC DAMPER	
703	LSJB8325	FRONT FPC	
704	B3RAB0000024	INFRARED RECEIVER	100EB/EG
705	LSEK0684	ELECTRIC CONDENSOR MICROPHONE UNIT	
711	LSSC0821	HEAT SINK ANGLE	
712	LSSC0822	MAIN SHIELD PLATE	
713	LSSC0830	HEAT SINK SHEET	
714	LSSC0896	HEAT CONDUCT SHEET	
721	K1NA09E00063	SD UNIT	150E/EB/EF/EG/EP/EE/GC/GN/GCS/SG,152EG,158GK
E10	LSEP8314P1	MAIN P.C.B.	RTL 100EB/EG,150E/EB/EF/EG/EP,152EG
E10	LSEP8314Q1	MAIN P.C.B.	RTL 150EE/GC/GN/GCS/SG,158GK
E20	LSEP8316A1	FRONT P.C.B.	RTL 100EB/EG
E20	LSEP8316C1	FRONT P.C.B.	RTL 150E/EB/EF/EG/EP/EE/GC/GN/GCS/SG,152EG,158GK
E30	LSEP8317A1	JACK P.C.B.	RTL
E40	LSEP8318A1	LIQUID CRYSTAL DISPLAY BACKLIGHT P.C.B. NR	
E50	LSEQ0805	CCD P.C.B. NR	
E60	LSEP8339A1	SIDE R P.C.B.	RTL 100EB/EG

Ref. No.	Part No.	Part Name & Description	Remarks
E60	LSEP8339B1	SIDE R P.C.B.	RTL 150E/EB /EF/EG/ EP/EE/G C/GN/GC S/SG,15 2EG,158 GK
E61	LSEP8340A1	OPEN SWITCH P.C.B.	RTL

Ref. No.	Part No.	Part Name & Description	Remarks
E60	LSEP8339B1	SIDE R P.C.B.	RTL 150E/EB /EF/EG/ EP/EE/G C/GN/GC S/SG,15 2EG,158 GK
E61	LSEP8340A1	OPEN SWITCH P.C.B.	RTL

SERVICE FIXTURES AND TOOLS

Ref. No.	Part No.	Part Name & Description	Remarks
	LSVQ0028	PLIER FOR NON ZIF CONNECTOR	
	LSUQ0050	GREASE	
	VUVS0007	EXTENSION CABLE 12P	
	VFKW0124A	EXTENSION CABLE 14P	
	LSUA0020	EXTENSION CABLE 20P	
	VUVS0012	EXTENSION CABLE 22P	
	LSUA0059	EXTENSION CABLE 60P	
	VFK1164LBX1	LIGHT BOX	SPC
	VFK1164TCM02	INFINITY LENS (WITH FOCUS CHART)	SPC
	VFK1164TAR58	ATTACHMENT RING (58mm)	SPC
	VFK1164TAR55	ATTACHMENT RING (55mm)	SPC
	VFK1164TAR52	ATTACHMENT RING (52mm)	SPC
	VFK1164TAR49	ATTACHMENT RING (49mm)	SPC
	VFK1164TAR46	ATTACHMENT RING (46mm)	SPC
	VFK1164TAR43	ATTACHMENT RING (43mm)	SPC
	VFK1164TAR37	ATTACHMENT RING (37mm)	SPC
	VFK1164TAR3A	ATTACHMENT RING (30.5mm)	SPC
	VFK1164TAR27	ATTACHMENT RING (27mm)	SPC
	VFK1164TFCT2	COLOR CONVERSION FILTER (C14)	SPC
	VFK1164TFWC2	WHITE CHART	SPC
	VFK1164TFCB2	COLOR BAR CHART	SPC
	VFK1164TFGS2	GRAY SCALE CHART	SPC

15.2.1. FRONT P.C.B.

INTEGRATED CIRCUITS

Ref. No.	Part No.	Part Name & Description	Remarks
IC4801	C0ABBB000369	IC, LINEAR	
or IC4801	C0ABBB000262	IC, LINEAR	

TRANSISTORS

Ref. No.	Part No.	Part Name & Description	Remarks
Q4801	2SD2216J08	TRANSISTOR SI NPN CHIP	
or Q4801	BLABCF000104	TRANSISTOR SI NPN CHIP	
Q6501	2SD10300SL	TRANSISTOR SI NPN CHIP	
Q6502	2SD2216J08	TRANSISTOR SI NPN CHIP	
or Q6502	BLABCF000104	TRANSISTOR SI NPN CHIP	

DIODES

Ref. No.	Part No.	Part Name & Description	Remarks
D6503	MA3S132D0L	DIODE SI CHIP	
D6504	B3GA00000041	LIGHT EMITTING DIODE	

RESISTORS

Ref. No.	Part No.	Part Name & Description	Remarks
R4802	DOGA472JA015	MGF CHIP 1/16W 4.7K	
R4803	DOGA223JA015	MGF CHIP 1/16W 22K	
R4804	DOGA333JA015	MGF CHIP 1/16W 33K	
R4805	ERJ2GEJ124X	MGF CHIP 1/16W 120K	
R4806	DOGA333JA015	MGF CHIP 1/16W 33K	
R4807	DOHA392ZA001	MGF CHIP 1/16W 3.9K	
R4808	ERJ2GEJ124X	MGF CHIP 1/16W 120K	
R4809	DOGA333JA015	MGF CHIP 1/16W 33K	
R4810	DOHA392ZA001	MGF CHIP 1/16W 3.9K	
R6501	ERJ2GEJ560X	MGF CHIP 1/16W 56	100EB/EG
R6502	DOGA683JA015	MGF CHIP 1/16W 68K	100EB/EG
R6503	ERJ2GEJ104X	MGF CHIP 1/16W 100K	
R6504	ERJ3GEYJ106V	MGF CHIP 1/16W 10M	
R6505	ERJ3GEYJ225V	MGF CHIP 1/16W 2.2M	
R6506	ERJ2GEJ334X	MGF CHIP 1/16W 330K	
R6507	DOGA182JA015	MGF CHIP 1/16W 1.8K	
R6508	DOGA472JA015	MGF CHIP 1/16W 4.7K	
R6509	DOGA102JA015	MGF CHIP 1/16W 1K	

CAPACITORS

Ref. No.	Part No.	Part Name & Description	Remarks
C4801	FIH1A105A036	C CHIP 10V 1UF	
C4802	FIH1A105A036	C CHIP 10V 1UF	
C4803	ECJ2FB0J106K	C CHIP 6.3V 10UF	
C4804	ECJ0EB1C822K	C CHIP 16V 8200PF	
C4805	ECJ0EB1A273K	C CHIP 10V 0.027UF	
C4806	ECJ0EB1A273K	C CHIP 10V 0.027UF	
C4808	ECJ0EB1A273K	C CHIP 10V 0.027UF	
C4809	ECJ0EB1C822K	C CHIP 16V 8200PF	
C4810	ECJ0EB1A273K	C CHIP 10V 0.027UF	
C4812	F3F0J226A032	TANTALUM CHIP 6.3V 22UF	
C6501	F3F0J106A032	TANTALUM CHIP 6.3V 10UF	100EB/EG
C6502	FI1G1A1040006	C CHIP 10V 0.1UF	100EB/EG
C6503	FIH0J474A002	C CHIP 6.3V 0.47UF	

15.2. ELECTRICAL REPLACEMENT PARTS LIST

Definition of Parts supplier:

1. All parts are supplied from PSEC.

PRINTED CIRCUIT BOARD ASSEMBLY

Ref. No.	Part No.	Part Name & Description	Remarks
E10	LSEP8314P1	MAIN P.C.B.	E.S.D. RTL 100EB/EG, 150E/EB/EF/EG, 15 2EG
E10	LSEP8314Q1	MAIN P.C.B.	E.S.D. RTL 150EE/G C/GN/GC S/SG,15 8GK
E20	LSEP8316A1	FRONT P.C.B.	RTL 100EB/EG
E20	LSEP8316C1	FRONT P.C.B.	RTL 150E/EB /EF/EG/ EP/EE/G C/GN/GC S/SG,15 2EG,158 GK
E30	LSEP8317A1	JACK P.C.B.	RTL
E40	LSEP8318A1	LIQUID CRYSTAL DISPLAY BACKLIGHT P.C.B. NR	
E50	LSEQ0805	CCD P.C.B. NR	
E60	LSEP8339A1	SIDE R P.C.B.	RTL 100EB/EG

Ref. No.	Part No.	Part Name & Description	Remarks
C6504	FLG1A1040006	C CHIP 10V 0.1UF	

FPC CONNECTORS

Ref. No.	Part No.	Part Name & Description	Remarks
FP6501	K1MN12BA0089	CONNECTOR 12P	

MISCELLANEOUS

Ref. No.	Part No.	Part Name & Description	Remarks
701	LSSC0827	FRONT EARTH PLATE A	
702	LSMG0136	MIC DAMPER	
703	LSJB8325	FRONT FPC	
704	B3RAB0000024	INFRARED RECEIVER	100EB/EG
705	LSEK0684	ELECTRIC CONDENSOR MICROPHONE UNIT	

15.2.2. JACK P.C.B.

DIODES

Ref. No.	Part No.	Part Name & Description	Remarks
D7001	MAZM068H0L	DIODE ZENER CHIP 6.8V	
D7002	MAZM068H0L	DIODE ZENER CHIP 6.8V	

RESISTORS

Ref. No.	Part No.	Part Name & Description	Remarks
R7001	D0GA122JA015	MGF CHIP 1/16W 1.2K	
R7002	ERJ2GE0R00X	MGF CHIP 1/16W 0	
R7003	ERJ2GE0R00X	MGF CHIP 1/16W 0	
R7004	ERJ6GEYJ102V	MGF CHIP 1/10W 1K	

CAPACITORS

Ref. No.	Part No.	Part Name & Description	Remarks
C7001	ECJ0EB1H332K	C CHIP 50V 3300PF	
C7002	ECJ0EB1H332K	C CHIP 50V 3300PF	
C7003	FIH1A105A036	C CHIP 10V 1UF	

COILS

Ref. No.	Part No.	Part Name & Description	Remarks
L7001	JOJBC0000027	FERRITE BEAD CHIP	
L7002	JOJBC0000027	FERRITE BEAD CHIP	
L7003	JOJBC0000027	FERRITE BEAD CHIP	
L7004	JOJBC0000027	FERRITE BEAD CHIP	
L7005	JOJBC0000027	FERRITE BEAD CHIP	

PIN HEADERS

Ref. No.	Part No.	Part Name & Description	Remarks
B7001	K1KA20BA0052	CONNECTOR 20P	

JACKS

Ref. No.	Part No.	Part Name & Description	Remarks
JK7001	K2HZ110E0001	AUDIO VIDEO S-VIDEO JACK SOCKET	
JK7002	K2HZ105E0007	USB MINI LACK SOCKET	

BATTERY

Ref. No.	Part No.	Part Name & Description	Remarks
BT7001	ML-621S/F9D	BATTERY	

15.2.3. LIQUID CRYSTAL DISPLAY BACKLIGHT P.C.B. NR

TRANSISTORS

Ref. No.	Part No.	Part Name & Description	Remarks
Q8101	2SD1819ARL	TRANSISTOR SI NPN CHIP	
Q8102	2SD1819ARL	TRANSISTOR SI NPN CHIP	
Q8103	2SD1819ARL	TRANSISTOR SI NPN CHIP	
Q8104	2SD1819ARL	TRANSISTOR SI NPN CHIP	

Ref. No.	Part No.	Part Name & Description	Remarks
Q8105	XP0450100L	TRANSISTOR COMPLX CMP SI NPN CHIP	
Q8106	XP0440100L	TRANSISTOR COMPLX CMP SI PNP CHIP	

DIODES

Ref. No.	Part No.	Part Name & Description	Remarks
D8109	MA2S728008	DIODE SI CHIP	
or D8109	B0JCDD000002	DIODE SI CHIP	
or D8109	MA2S72800L	DIODE SI CHIP	
D8110	MA2S728008	DIODE SI CHIP	
or D8110	B0JCDD000002	DIODE SI CHIP	
or D8110	MA2S72800L	DIODE SI CHIP	

RESISTORS

Ref. No.	Part No.	Part Name & Description	Remarks
R8101	ERJ3GEY0R00V	MGF CHIP 1/16W 0	
R8102	ERJ3GEYJ331V	MGF CHIP 1/16W 330	
R8103	ERJ3GEYJ331V	MGF CHIP 1/16W 330	
R8104	ERJ3GEY0R00V	MGF CHIP 1/16W 0	
R8105	ERJ3GEY0R00V	MGF CHIP 1/16W 0	
R8106	ERJ3GEYJ331V	MGF CHIP 1/16W 330	
R8107	ERJ3GEY0R00V	MGF CHIP 1/16W 0	
R8108	D0HB470ZA003	MGF CHIP 1/16W 47	
R8109	D0HB470ZA003	MGF CHIP 1/16W 47	
R8110	D0HB470ZA003	MGF CHIP 1/16W 47	
R8111	D0HB470ZA003	MGF CHIP 1/16W 47	
R8112	ERJ3GEYJ103V	MGF CHIP 1/16W 10K	
R8113	ERJ3GEYJ103V	MGF CHIP 1/16W 10K	
R8114	ERA3YKD104V	MGF CHIP 1/16W 100K	
R8115	ERA3YED123V	MGF CHIP 1/16W 12K	
R8116	ERA3YKD184V	MGF CHIP 1/16W 180K	
R8117	ERJ3GEYJ393V	MGF CHIP 1/16W 39K	
R8118	ERJ3GEYJ393V	MGF CHIP 1/16W 39K	
R8119	ERJ3GEYJ153V	MGF CHIP 1/16W 15K	
R8120	ERJ3GEYJ113V	MGF CHIP 1/16W 11K	

CAPACITORS

Ref. No.	Part No.	Part Name & Description	Remarks
C8101	F1H1H330A230	C CHIP 50V 33PF	
C8102	F1H1H330A230	C CHIP 50V 33PF	
C8103	F1H1H330A230	C CHIP 50V 33PF	
C8104	F1J1C2250003	C CHIP 16V 2.2UF	
C8105	F1J1C2250003	C CHIP 16V 2.2UF	
C8106	F1H1C104A041	C CHIP 16V 0.1UF	
C8107	ECJ3YB1C475K	C CHIP 16V 4.7UF	
C8108	F1J1C1050028	C CHIP 16V 1UF	
C8109	F1J1C1050028	C CHIP 16V 1UF	
C8110	F1J1C1050028	C CHIP 16V 1UF	

COILS

Ref. No.	Part No.	Part Name & Description	Remarks
L8101	G1C100M00010	COIL CHIP 10UH	
L8102	G1C100M00010	COIL CHIP 10UH	
L8103	G1C100M00010	COIL CHIP 10UH	
L8104	G1C100M00010	COIL CHIP 10UH	

FPC CONNECTORS

Ref. No.	Part No.	Part Name & Description	Remarks
FP8101	K1MN26BA0059	CONNECTOR 26P	
FP8102	K1MN24BA0059	CONNECTOR 24P	

15.2.4. SIDE R P.C.B.

TRANSISTORS

Ref. No.	Part No.	Part Name & Description	Remarks
Q6301	2SB09700RL	TRANSISTOR SI PNP CHIP	150E/EB /EF/EG/ EP/EE/G C/GN/GC S/SG,15 2EG,158 GK

DIODES

Ref. No.	Part No.	Part Name & Description	Remarks
D6301	B3AAB0000038	LIGHT EMITTING DIODE	150E/EB /EF/EG/ EP/EE/G C/GN/GC S/SG,15 2EG,158 GK

RESISTORS

Ref. No.	Part No.	Part Name & Description	Remarks
R6301	ERJ3GEYJ220V	MGF CHIP 1/16W 22	150E/EB /EF/EG/ EP/EE/G C/GN/GC S/SG,15 2EG,158 GK
R6302	ERJ3GEYJ220V	MGF CHIP 1/16W 22	150E/EB /EF/EG/ EP/EE/G C/GN/GC S/SG,15 2EG,158 GK
R6303	ERJ3GEYJ220V	MGF CHIP 1/16W 22	150E/EB /EF/EG/ EP/EE/G C/GN/GC S/SG,15 2EG,158 GK
R6304	ERJ3GEYJ220V	MGF CHIP 1/16W 22	150E/EB /EF/EG/ EP/EE/G C/GN/GC S/SG,15 2EG,158 GK
R6305	ERJ3GEYJ220V	MGF CHIP 1/16W 22	150E/EB /EF/EG/ EP/EE/G C/GN/GC S/SG,15 2EG,158 GK
R6306	ERJ3GEYJ103V	MGF CHIP 1/16W 10K	
R6307	ERJ3GEYJ103V	MGF CHIP 1/16W 10K	
R6308	ERJ3GEYJ103V	MGF CHIP 1/16W 10K	
R6309	ERJ3GEYJ103V	MGF CHIP 1/16W 10K	
R6310	ERJ3GEYJ103V	MGF CHIP 1/16W 10K	
R6311	ERJ3GEYJ220V	MGF CHIP 1/16W 22	
R6312	ERJ3GEYJ220V	MGF CHIP 1/16W 22	
R6313	ERJ3GEYJ220V	MGF CHIP 1/16W 22	
R6314	ERJ3GEYJ220V	MGF CHIP 1/16W 22	
R6315	ERJ3GEYJ220V	MGF CHIP 1/16W 22	
R6316	ERJ3GEYJ223V	MGF CHIP 1/16W 22K	
R6317	ERJ3GEYJ223V	MGF CHIP 1/16W 22K	
R6323	ERJ3GEYJ561V	MGF CHIP 1/16W 560	150E/EB /EF/EG/ EP/EE/G C/GN/GC S/SG,15 2EG,158 GK

Ref. No.	Part No.	Part Name & Description	Remarks
R6324	ERJ3GEY0R00V	MGF CHIP 1/16W 0	150E/EB /EF/EG/ EP/EE/G C/GN/GC S/SG,15 2EG,158 GK
R6325	ERJ6GEYJ150V	MGF CHIP 1/10W 15	150E/EB /EF/EG/ EP/EE/G C/GN/GC S/SG,15 2EG,158 GK

CAPACITORS

Ref. No.	Part No.	Part Name & Description	Remarks
C6301	F3F0J226A032	TANTALUM CHIP 6.3V 22UF	150E/EB /EF/EG/ EP/EE/G C/GN/GC S/SG,15 2EG,158 GK
C6302	F1H1C104A041	C CHIP 16V 0.1UF	150E/EB /EF/EG/ EP/EE/G C/GN/GC S/SG,15 2EG,158 GK
C6303	F1H1C104A041	C CHIP 16V 0.1UF	150E/EB /EF/EG/ EP/EE/G C/GN/GC S/SG,15 2EG,158 GK
C6304	F1H1H330A230	C CHIP 50V 33PF	150E/EB /EF/EG/ EP/EE/G C/GN/GC S/SG,15 2EG,158 GK
C6305	F1H1H330A230	C CHIP 50V 33PF	150E/EB /EF/EG/ EP/EE/G C/GN/GC S/SG,15 2EG,158 GK
C6306	F1H1H330A230	C CHIP 50V 33PF	150E/EB /EF/EG/ EP/EE/G C/GN/GC S/SG,15 2EG,158 GK
C6307	F1H1H330A230	C CHIP 50V 33PF	150E/EB /EF/EG/ EP/EE/G C/GN/GC S/SG,15 2EG,158 GK
C6308	F1H1H330A230	C CHIP 50V 33PF	150E/EB /EF/EG/ EP/EE/G C/GN/GC S/SG,15 2EG,158 GK
C6310	F1H1H103A219	C CHIP 50V 0.01UF	150E/EB /EF/EG/ EP/EE/G C/GN/GC S/SG,15 2EG,158 GK

COILS

Ref. No.	Part No.	Part Name & Description	Remarks
L6301	G1C100M00010	COIL CHIP 10UH	

Ref. No.	Part No.	Part Name & Description	Remarks
L6302	ERJ3GEYJ181V	MGF CHIP 1/16W 180	150E/EB /EF/EG/ EP/EE/G C/GN/GC S/SG,15 2EG,158 GK

PIN HEADERS

Ref. No.	Part No.	Part Name & Description	Remarks
P6301	K1KA02BA0014	CONNECTOR 2P	

FPC CONNECTOR

Ref. No.	Part No.	Part Name & Description	Remarks
FP6301	K1MN22BA0089	CONNECTOR 22P	

SWITCHES

Ref. No.	Part No.	Part Name & Description	Remarks
SW6301	K0F111A00472	PUSH SWITCH	
SW6302	K0D113B00087	SWITCH SLIDE	

MISCELLANEOUS

Ref. No.	Part No.	Part Name & Description	Remarks
721	K1NA09E00063	SD UNIT	150E/EB /EF/EG/ EP/EE/G C/GN/GC S/SG,15 2EG,158 GK

15.2.5. OPEN SWITCH P.C.B.

SWITCHES

Ref. No.	Part No.	Part Name & Description	Remarks
SW8301	K0L1AA000010	SWITCH SEESAW	