

Service Manual

Digital Camera

LUMIX  HDMI

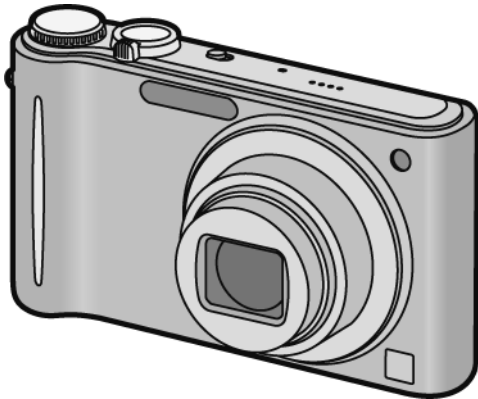

Model No. **DMC-ZX3EB**
DMC-ZX3EE
DMC-ZX3EF
DMC-ZX3EG
DMC-ZX3EP
DMC-ZX3SG
DMC-ZR3P
DMC-ZR3PC
DMC-ZR3PR
DMC-ZR3PU
DMC-ZR3GC
DMC-ZR3GD
DMC-ZR3GH
DMC-ZR3GK
DMC-ZR3GN
DMC-ZR3GT

Vol. 1

Colour
 [DMC-ZX3]
 (S).....Silver Type (except EF)
 (K).....Black Type (except SG)
 (N).....Gold Type (only SG)
 (R).....Red Type (except EE)
 (T).....Brown Type (except EB/EE)
 (A).....Blue Type (except EF/SG)

[DMC-ZR3]
 (S).....Silver Type (except PC/PR/GT/GD)
 (K).....Black Type
 (N).....Gold Type (only GC/GH/GT)
 (R).....Red Type (except PC/PR/GD)
 (T).....Brown Type (only GD/GH/GN)
 (A).....Blue Type (only P/PC/PU/GN)

⚠ WARNING

This service information is designed for experienced repair technicians only and is not designed for use by the general public. It does not contain warnings or cautions to advise non-technical individuals of potential dangers in attempting to service a product. Products powered by electricity should be serviced or repaired only by experienced professional technicians. Any attempt to service or repair the product or products dealt with in this service information by anyone else could result in serious injury or death.

TABLE OF CONTENTS

	PAGE		PAGE
1 Safety Precautions	3	9 Measurements and Adjustments	42
1.1. General Guidelines	3	9.1. Introduction	42
1.2. Leakage Current Cold Check	3	9.2. Before Disassembling the unit	42
1.3. Leakage Current Hot Check (See Figure 1.)	3	9.3. Details of Electrical Adjustment	44
1.4. How to Discharge the Capacitor on E.Capacitor P.C.B.	4	9.4. After Adjustment	47
2 Warning	5	10 Maintenance	48
2.1. Prevention of Electrostatic Discharge (ESD) to Electrostatically Sensitive (ES) Devices	5	10.1. Cleaning Lens and LCD Panel	48
2.2. How to Recycle the Lithium Ion Battery (U.S. Only)	5		
2.3. Caution for AC Cord(For EB/GC/GH)	6		
2.4. How to Replace the Lithium Battery	7		
3 Service Navigation	8		
3.1. Introduction	8		
3.2. General Description About Lead Free Solder (PbF)	8		
3.3. Important Notice 1:(Other than U.S.A. and Canadian Market)	8		
3.4. How to Define the Model Suffix (NTSC or PAL model)	9		
4 Specifications	13		
5 Location of Controls and Components	14		
6 Service Mode	18		
6.1. Error Code Memory Function	18		
6.2. ICS (Indication of additional Camera Settings when picture was taken) function	20		
7 Service Fixture & Tools	22		
7.1. Service Fixture and Tools	22		
7.2. When Replacing the Main P.C.B.	23		
7.3. Service Position	23		
8 Disassembly and Assembly Instructions	24		
8.1. Disassembly Flow Chart	24		
8.2. P.C.B. Location	24		
8.3. Disassembly Procedure	25		
8.4. Lens Disassembly Procedure	31		
8.5. Assembly Procedure for the Lens	36		
8.6. Removal of the CCD Unit	40		
8.7. Removal of the Focus Motor	41		
8.8. The Application of Grease Method	41		

1 Safety Precautions

1.1. General Guidelines

1. IMPORTANT SAFETY NOTICE

There are special components used in this equipment which are important for safety. These parts are marked by

 in the Schematic Diagrams, Circuit Board Layout, Exploded Views and Replacement Parts List. It is essential that these critical parts should be replaced with manufacturer's specified parts to prevent X-RADIATION, shock, fire, or other hazards. Do not modify the original design without permission of manufacturer.

2. An Isolation Transformer should always be used during the servicing of AC Adaptor whose chassis is not isolated from the AC power line. Use a transformer of adequate power rating as this protects the technician from accidents resulting in personal injury from electrical shocks. It will also protect AC Adaptor from being damaged by accidental shorting that may occur during servicing.
3. When servicing, observe the original lead dress. If a short circuit is found, replace all parts which have been overheated or damaged by the short circuit.
4. After servicing, see to it that all the protective devices such as insulation barriers, insulation papers shields are properly installed.
5. After servicing, make the following leakage current checks to prevent the customer from being exposed to shock hazards.

1.2. Leakage Current Cold Check

1. Unplug the AC cord and connect a jumper between the two prongs on the plug.
2. Measure the resistance value, with an ohmmeter, between the jumpered AC plug and each exposed metallic cabinet part on the equipment such as screwheads, connectors, control shafts, etc. When the exposed metallic part has a return path to the chassis, the reading should be between $1\text{ M}\Omega$ and $5.2\text{ M}\Omega$. When the exposed metal does not have a return path to the chassis, the reading must be infinity.

1.3. Leakage Current Hot Check (See Figure 1.)

1. Plug the AC cord directly into the AC outlet. Do not use an isolation transformer for this check.
2. Connect a $1.5\text{ k}\Omega$, 10 W resistor, in parallel with a $0.15\text{ }\mu\text{F}$ capacitor, between each exposed metallic part on the set and a good earth ground, as shown in Figure 1.
3. Use an AC voltmeter, with $1\text{ k}\Omega/\text{V}$ or more sensitivity, to measure the potential across the resistor.
4. Check each exposed metallic part, and measure the voltage at each point.
5. Reverse the AC plug in the AC outlet and repeat each of the above measurements.
6. The potential at any point should not exceed 0.75 V RMS . A leakage current tester (Simpson Model 229 or equivalent) may be used to make the hot checks, leakage current must not exceed $1/2\text{ mA}$. In case a measurement is outside of the limits specified, there is a possibility of a shock hazard, and the equipment should be repaired and rechecked before it is returned to the customer.

Hot-Check Circuit



Figure. 1

1.4. How to Discharge the Capacitor on E.Capacitor P.C.B.

CAUTION:

1. Be sure to discharge the capacitor on E.Capacitor P.C.B..
2. Be careful of the high voltage circuit on E.Capacitor P.C.B. when servicing.

[Discharging Procedure]

1. Refer to the disassemble procedure and remove the necessary parts/unit.
2. Install the insulation tube onto the lead part of resistor (ERG5SJ102:1k Ω /5W).
(an equivalent type of resistor may be used.)
3. Place a resistor between both terminals of capacitor on the E.Capacitor P.C.B. for approx. 5 seconds.
4. After discharging, confirm that the capacitor voltage is lower than 10V using a voltmeter.

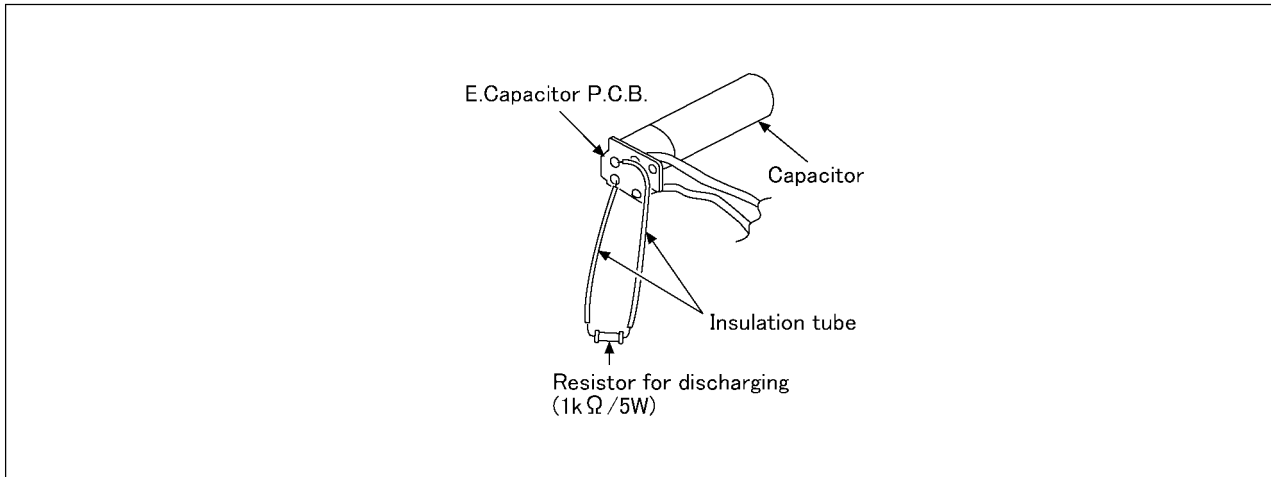

Fig. F1

2 Warning

2.1. Prevention of Electrostatic Discharge (ESD) to Electrostatically Sensitive (ES) Devices

Some semiconductor (solid state) devices can be damaged easily by static electricity. Such components commonly are called Electrostatically Sensitive (ES) Devices.

Examples of typical ES devices are CCD image sensor, IC (integrated circuits) and some field-effect transistors and semiconductor "chip" components.

The following techniques should be used to help reduce the incidence of component damage caused by electrostatic discharge (ESD).

1. Immediately before handling any semiconductor component or semiconductor-equipped assembly, drain off any ESD on your body by touching a known earth ground. Alternatively, obtain and wear a commercially available discharging ESD wrist strap, which should be removed for potential shock reasons prior to applying power to the unit under test.
2. After removing an electrical assembly equipped with ES devices, place the assembly on a conductive surface such as aluminum foil, to prevent electrostatic charge buildup or exposure of the assembly.
3. Use only a grounded-tip soldering iron to solder or unsolder ES devices.
4. Use only an antistatic solder removal device. Some solder removal devices not classified as "antistatic (ESD protected)" can generate electrical charge sufficient to damage ES devices.
5. Do not use freon-propelled chemicals. These can generate electrical charges sufficient to damage ES devices.
6. Do not remove a replacement ES device from its protective package until immediately before you are ready to install it. (Most replacement ES devices are packaged with leads electrically shorted together by conductive foam, aluminum foil or comparable conductive material).
7. Immediately before removing the protective material from the leads of a replacement ES device, touch the protective material to the chassis or circuit assembly into which the device will be installed.

CAUTION :

Be sure no power is applied to the chassis or circuit, and observe all other safety precautions.

8. Minimize bodily motions when handling unpackaged replacement ES devices. (Otherwise harmless motion such as the brushing together of your clothes fabric or the lifting of your foot from a carpeted floor can generate static electricity (ESD) sufficient to damage an ES device).

2.2. How to Recycle the Lithium Ion Battery (U.S. Only)

ENGLISH



A lithium ion battery that is recyclable powers the product you have purchased. Please call 1-800-8-BATTERY for information on how to recycle this battery.

FRANÇAIS



L'appareil que vous vous êtes procuré est alimenté par une batterie au lithium-ion recyclable. Pour des renseignements sur le recyclage de la batterie, veuillez composer le 1-800-8-BATTERY.

2.3. Caution for AC Cord (For EB/GC/GH)

2.3.1. Information for Your Safety

IMPORTANT

Your attention is drawn to the fact that recording of pre-recorded tapes or discs or other published or broadcast material may infringe copyright laws.

WARNING

To reduce the risk of fire or shock hazard, do not expose this equipment to rain or moisture.

CAUTION

To reduce the risk of fire or shock hazard and annoying interference, use the recommended accessories only.

FOR YOUR SAFETY

DO NOT REMOVE THE OUTER COVER

To prevent electric shock, do not remove the cover. No user serviceable parts inside. Refer servicing to qualified service personnel.

2.3.2. Caution for AC Mains Lead

For your safety, please read the following text carefully.

This appliance is supplied with a moulded three-pin mains plug for your safety and convenience.

A 5-ampere fuse is fitted in this plug.

Should the fuse need to be replaced please ensure that the replacement fuse has a rating of 5 amperes and it is approved by ASTA or BSI to BS1362

Check for the ASTA mark or the BSI mark on the body of the fuse.



If the plug contains a removable fuse cover you must ensure that it is refitted when the fuse is replaced.

If you lose the fuse cover, the plug must not be used until a replacement cover is obtained.

A replacement fuse cover can be purchased from your local Panasonic Dealer.

If the fitted moulded plug is unsuitable for the socket outlet in your home then the fuse should be removed and the plug cut off and disposed of safely.

There is a danger of severe electrical shock if the cut off plug is inserted into any 13-ampere socket.

If a new plug is to be fitted please observe the wiring code as shown below.

If in any doubt, please consult a qualified electrician.

2.3.2.1. Important

The wires in this mains lead are coloured in accordance with the following code:

Blue	Neutral
Brown	Live

As the colours of the wires in the mains lead of this appliance may not correspond with the coloured markings identifying the terminals in your plug, proceed as follows:

The wire which is coloured BLUE must be connected to the terminal in the plug which is marked with the letter N or coloured BLACK.

The wire which is coloured BROWN must be connected to the terminal in the plug which is marked with the letter L or coloured RED.

Under no circumstances should either of these wires be connected to the earth terminal of the three pin plug, marked with the letter E or the Earth Symbol.



2.3.2.2. Before Use

Remove the Connector Cover as follows.



2.3.2.3. How to Replace the Fuse

1. Remove the Fuse Cover with a screwdriver.



2. Replace the fuse and attach the Fuse cover.



2.4. How to Replace the Lithium Battery

2.4.1. Replacement Procedure

1. Remove the FLASH TOP P.C.B.. (Refer to Disassembly Procedures.)
2. Remove the Lithium battery (Ref. No. "B8001" at foil side of FLASH TOP P.C.B.) and then replace it into new one.

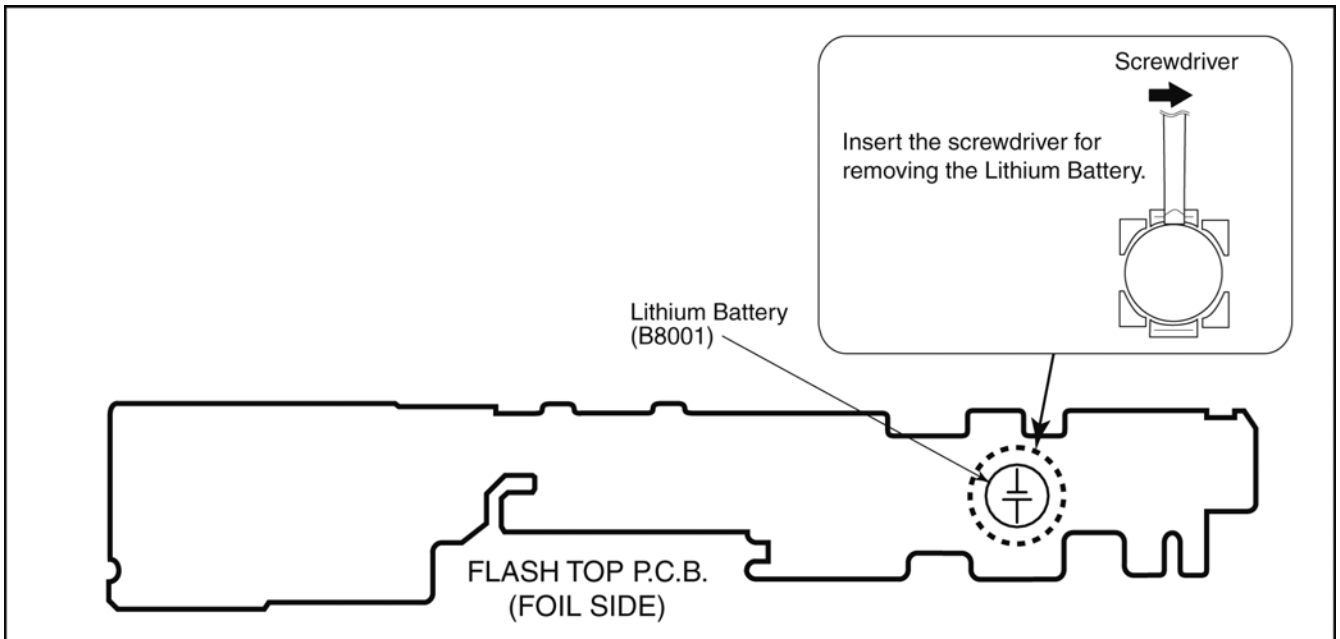

NOTE:

This Lithium battery is a critical component.

(Type No.: ML421 **Manufactured by Energy Company, Panasonic Corporation.**)

It must never be subjected to excessive heat or discharge.

It must therefore only be fitted in requirement designed specifically for its use.

Replacement batteries must be of same type and manufacture.

They must be fitted in the same manner and location as the original battery, with the correct polarity contacts observed.

Do not attempt to re-charge the old battery or re-use it for any other purpose.

It should be disposed of in waste products destined for burial rather than incineration.

(For English)

CAUTION

Danger of explosion if battery is incorrectly replaced.

Replace only with the same or equivalent type recommended by the manufacturer.

Dispose of used batteries according to the manufacturer's instructions.

(For German)

ACHTUNG

Explosionsgefahr bei falschem Anbringen der Batterie. Ersetzen Sie nur mit einem äquivalentem vom Hersteller empfohlenem Typ.

Behandeln Sie gebrauchte Batterien nach den Anweisungen des Herstellers.

(For French)

MISE EN GARDE

Une batterie de remplacement inappropriée peut exploser. Ne remplacez qu'avec une batterie identique ou d'un type recommandé par le fabricant. L'élimination des batteries usées doit être faite conformément aux instructions du fabricant.

NOTE:

Above caution is applicable for a battery pack which is for DMC-ZX3, ZR3 series, as well.

3 Service Navigation

3.1. Introduction

This service manual contains technical information, which allow service personnel's to understand and service this model.

Please place orders using the parts list and not the drawing reference numbers.

If the circuit is changed or modified, the information will be followed by service manual to be controlled with original service manual.

3.2. General Description About Lead Free Solder (PbF)

The lead free solder has been used in the mounting process of all electrical components on the printed circuit boards used for this equipment in considering the globally environmental conservation.

The normal solder is the alloy of tin (Sn) and lead (Pb). On the other hand, the lead free solder is the alloy mainly consists of tin (Sn), silver (Ag) and Copper (Cu), and the melting point of the lead free solder is higher approx.30°C (86°F) more than that of the normal solder.

Distinction of P.C.B. Lead Free Solder being used

The letter of "PbF" is printed either foil side or components side on the P.C.B. using the lead free solder.(See right figure)
--

PbF

Service caution for repair work using Lead Free Solder (PbF)

- The lead free solder has to be used when repairing the equipment for which the lead free solder is used.
(Definition: The letter of "PbF" is printed on the P.C.B. using the lead free solder.)
- To put lead free solder, it should be well molten and mixed with the original lead free solder.
- Remove the remaining lead free solder on the P.C.B. cleanly for soldering of the new IC.
- Since the melting point of the lead free solder is higher than that of the normal lead solder, it takes the longer time to melt the lead free solder.
- Use the soldering iron (more than 70W) equipped with the temperature control after setting the temperature at 350±30°C (662±86°F).

Recommended Lead Free Solder (Service Parts Route.)

- The following 3 types of lead free solder are available through the service parts route.
 - RFKZ03D01KS----- (0.3mm 100g Reel)
 - RFKZ06D01KS----- (0.6mm 100g Reel)
 - RFKZ10D01KS----- (1.0mm 100g Reel)

Note

* Ingredient: tin (Sn) 96.5%, silver (Ag) 3.0%, Copper (Cu) 0.5%, Cobalt (Co) / Germanium (Ge) 0.1 to 0.3%

3.3. Important Notice 1:(Other than U.S.A. and Canadian Market)

1. The service manual does not contain the following information because of issues servicing to component level without necessary equipment/facilities.
 - a. Schematic diagram, Block Diagram and P.C.B. layout of MAIN P.C.B..
 - b. Parts list for individual parts for MAIN P.C.B..

When a part replacement is required for repairing MAIN P.C.B., replace as an assembled parts. (MAIN P.C.B.)

2. The following category is/are recycle module part. please send it/them to Central Repair Center.
 - MAIN P.C.B. (VEP56100A: P/PC/PU/EE/GC/GD/GH/GK/GN/GT/SG)
 - MAIN P.C.B. (VEP56100B: PR/EB/EF/EG/EP)

3.4. How to Define the Model Suffix (NTSC or PAL model)









There are nine kinds of DMC-ZX3/ZR3, regardless of the colours.

- a) DMC-ZX3 (Japan domestic model), DMC-ZX3SG
- b) DMC-ZR3P/PC
- c) DMC-ZX3EB/EF/EG/EP
- d) DMC-ZX3EE
- e) DMC-ZR3GT
- f) DMC-ZR3GK
- g) DMC-ZR3GD
- h) DMC-ZR3GN
- i) DMC-ZR3PR/PU/GC/GH

What is the difference is that the "INITIAL SETTINGS" data which is stored in Flash-ROM mounted on MAIN P.C.B..

3.4.1. Defining methods:

To define the model suffix to be serviced, refer to the nameplate which is putted on the bottom side of the Unit.

<p>a) DMC-ZX3 (Japan domestic model), DMC-ZX3SG The nameplate for these models show the following Safety registration mark.</p> 
<p>b) DMC-ZR3P/PC The nameplate for these models show the following Safety registration mark.</p> 
<p>c) DMC-ZX3EB/EF/EG/EP The nameplate for these models show the following Safety registration mark.</p> 
<p>d) DMC-ZX3EE The nameplate for this model show the following Safety registration mark.</p> 
<p>e) DMC-ZR3GT The nameplate for this model show the following Safety registration mark.</p> 
<p>f) DMC-ZR3GK The nameplate for this model show the following Safety registration mark.</p> 
<p>g) DMC-ZR3GD The nameplate for this model show the following Safety registration mark.</p> 
<p>h) DMC-ZR3GN The nameplate for this model show the following Safety registration mark.</p> 
<p>i) DMC-ZR3PR/PU/GC/GH The nameplate for these models do not show any above Safety registration mark.</p>

NOTE:

After replacing the MAIN P.C.B., be sure to achieve adjustment.

The adjustment instruction is available at "software download" on the "Support Information from NWBG/VDBG-AVC" web-site in "TSN system", together with Maintenance software.

3.4.2. INITIAL SETTINGS:

After replacing the MAIN P.C.B., be sure to perform the initial settings after achieving the adjustment by ordering the following procedure in accordance with model suffix of the unit.

1. IMPORTANT NOTICE:

Before proceeding Initial settings, be sure to read the following CAUTIONS.

CAUTION 1:(INITIAL SETTINGS)

---AFTER REPLACING THE MAIN P.C.B. ---

[Except "EG, EF, EB, PR and EP" models : (VEP56100A is used as a Main P.C.B.)]

*.The model suffix can be chosen **JUST ONE TIME.**

(Effective model suffix : " P/PU/GD/GC/GT/GK/EE/GN/PC/SG/GH and NONE(JAPAN)")

*.Once one of the model suffix has been chosen, the model suffix lists will not be displayed, thus, it can not be changed.

[Only for "EG, EF, EB, PR and EP" models : (VEP56100B is used as a Main P.C.B.)]

*.From the beginning, only "EG, EF, EB, PR and EP" are displayed as model suffix lists, and these are displayed from the second times as well.

CAUTION 2:(Stored picture image data in the unit)

This unit employs "Built-in Memory" for picture image data recording.(Approx.40MB)
After proceeding "INITIAL SETTINGS", the picture image data stored in the unit is erased.

2. PROCEDURES:

• Precautions: Read the above "CAUTION 1" and "CAUTION 2", carefully.

• Preparation:

1. Attach the Battery or AC Adaptor with a DC coupler to the unit.

(Since this unit has built-in memory, it can be performed without inserting SD memory card.)

2. Set the recording mode to the [NORMAL PICTURE] mode.

(Rotate the Mode dial to adjust to the [NORMAL PICTURE] mode. (Camera mark))

NOTE:

If the unit is other than [NORMAL PICTURE] mode, it does not display the initial settings menu.

• **Step 1. The temporary cancellation of "INITIAL SETTINGS":**

Set the [REC]/[PLAYBACK] selector switch to "[REC] (Camera mark)".

While keep pressing "[UP] of Cursor button" and [DISPLAY] button simultaneously, turn the Power on.

• **Step 2. The cancellation of "INITIAL SETTINGS":**

Set the [REC]/[PLAYBACK] selector switch to "[PLAYBACK]".

Press "[UP] of Cursor button" and [DISPLAY] button simultaneously, then turn the Power off.

• **Step 3. Turn the Power on:**

Set the [REC]/[PLAYBACK] selector switch to "[REC] (Camera mark)", and then turn the Power on.

• **Step 4. Display the INITIAL SETTING:**

While keep pressing [MENU/SET] and "[RIGHT] of Cursor buttons" simultaneously, turn the Power off.

The "INITIAL SETTINGS" menu is displayed.

There are two kinds of "INITIAL SETTINGS" menu form as follows:

[CASE 1. After replacing MAIN P.C.B.]

[Except "EG, EF, EB, PR and EP" models: (VEP56100A is used as a Main P.C.B.)

When MAIN P.C.B. has just been replaced, all of the model suffix is displayed as follows. (Three pages in total)

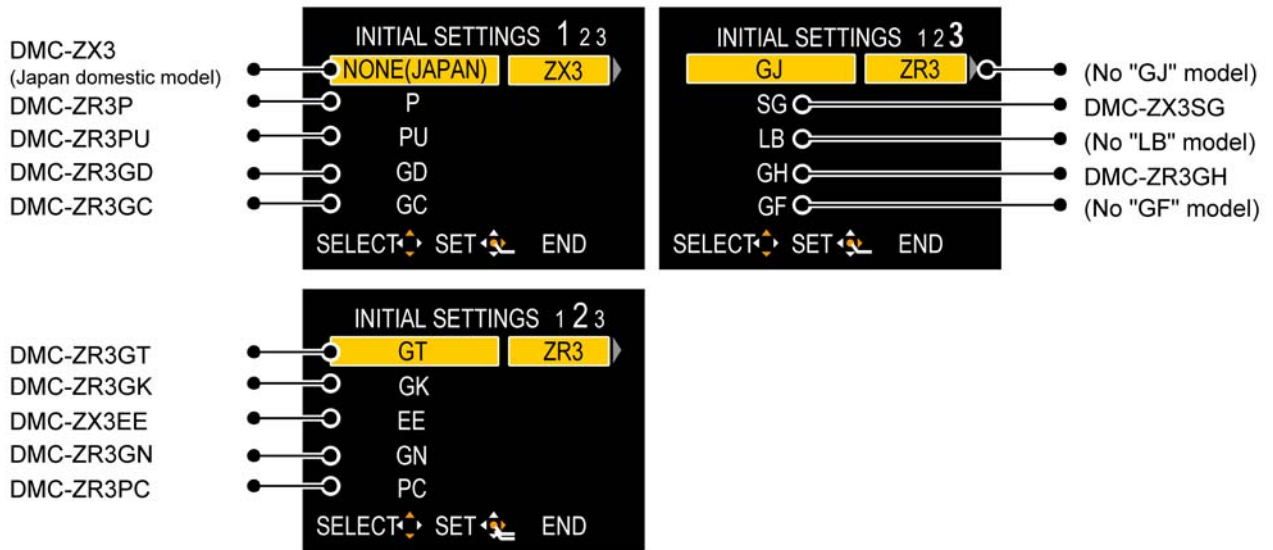

[Only "EG, EF, EB, PR and EP" models: (VEP56100B is used as a Main P.C.B.)

When MAIN P.C.B. has just been replaced, only 7 model suffix are displayed as follows. (Two pages in total)



[CASE 2. Other than "After replacing MAIN P.C.B."]

<Other than "EG/EF/EB/EE/EP" models>

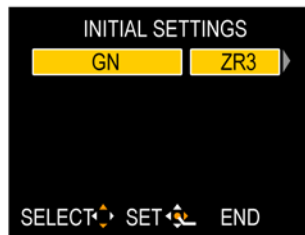

<Only "EG/EF/EB/EE/EP" models>

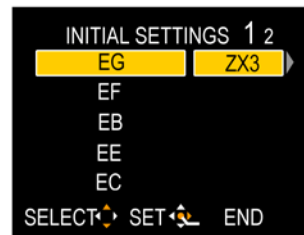

• **Step 5. Choose the model suffix in "INITIAL SETTINGS": (Refer to "CAUTION 1")**

[Caution: After replacing MAIN P.C.B.]

The model suffix can be chosen, **JUST ONE TIME.**

Once one of the model suffix have been chosen, the model suffix lists will not be displayed, thus, it can not be changed.

Therefore, select the area carefully.

Select the area with pressing "[UP] / [DOWN] of Cursor buttons".

• **Step 6. Set the model suffix in “INITIAL SETTINGS”:**

- Press the “[RIGHT] of Cursor buttons”.
- The only set area is displayed, and then press the “[RIGHT] of Cursor buttons” after confirmation.
(The unit is powered off automatically.)

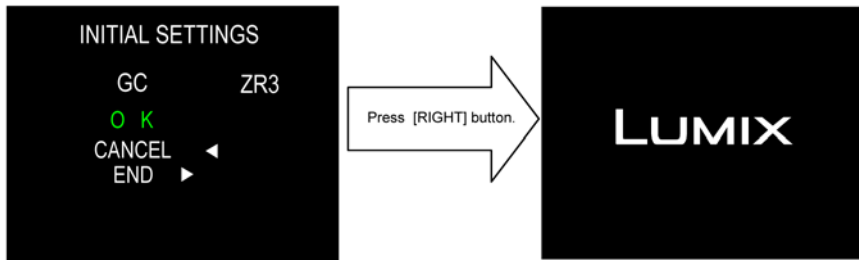

• **Step 7. CONFIRMATION:**

Confirm the display of “PLEASE SET THE CLOCK” in concerned language when the unit is turned on again.
When the unit is connected to PC with USB cable, it is detected as removable media.

1) As for your reference, major default setting condition is as shown in the following table.

• **Default setting (After “INITIAL SETTINGS”)**

	MODEL	VIDEO OUTPUT	LANGUAGE	DATE	REMARKS
a)	DMC-ZX3 (Japan domestic model)	NTSC	Japanese	Year/Month/Date	
b)	DMC-ZR3P	NTSC	English	Month/Date/Year	
c)	DMC-ZX3EG	PAL	English	Date/Month/Year	
d)	DMC-ZX3EP	PAL	English	Date/Month/Year	
e)	DMC-ZR3PU	NTSC	English	Month/Date/Year	
f)	DMC-ZR3GD	NTSC	Korean	Year/Month/Date	
g)	DMC-ZR3GC	PAL	English	Date/Month/Year	
h)	DMC-ZR3GT	NTSC	Chinese (traditional)	Year/Month/Date	
i)	DMC-ZR3GK	PAL	Chinese (simplified)	Year/Month/Date	
j)	DMC-ZX3EF	PAL	French	Date/Month/Year	
k)	DMC-ZX3EB	PAL	English	Date/Month/Year	
l)	DMC-ZX3EE	PAL	Russian	Date/Month/Year	
m)	DMC-ZR3GN	PAL	English	Date/Month/Year	
n)	DMC-ZR3PC	NTSC	English	Month/Date/Year	
o)	DMC-ZR3PR	PAL	English	Date/Month/Year	
p)	DMC-ZX3SG	PAL	English	Date/Month/Year	
q)	DMC-ZR3GH	PAL	English	Date/Month/Year	

4 Specifications

Digital Camera: Information for your safety

Power Source:	DC 5.1 V
Power Consumption:	1.2 W (When recording) 0.6 W (When playing back)

Camera effective pixels: 14,100,000 pixels
Image sensor: 1/2.33" CCD, total pixel number 14,500,000 pixels, Primary color filter
Lens: Optical 8×zoom, f=4.5 mm to 36 mm (35 mm film camera equivalent: 25 mm to 200 mm)/F3.3 to F5.9
Digital zoom: Max. 4×
Extended optical zoom: Max. 16.9×
Focus range: Normal: 50 cm (1.64 feet) (Wide)/2 m (6.56 feet) (Tele) to ∞
 Macro/Intelligent Auto/Clipboard Mode: 3 cm (0.10 feet) (Wide)/1 m (3.28 feet) (Tele) to ∞
 Scene Mode: There may be differences in the above settings.
Shutter system: Electronic shutter+Mechanical shutter
Burst recording Burst speed: Approx. 1.8 pictures/second
Number of recordable pictures: Max. 5 pictures (Standard), max. 3 pictures (Fine).
Hi-speed burst Burst speed: Approx. 10 pictures/second (Speed priority)
 Approx. 6 pictures/second (Image priority)
 [3M (4:3), 2.5M (3:2) or 2M (16:9) is selected as the picture size.]
Number of recordable pictures: Approx. 15 to 100
Shutter speed: 8 seconds to 1/2000th of a second
 [STARRY SKY] Mode: 15 seconds, 30 seconds, 60 seconds
Exposure (AE): Program AE
 Exposure compensation (1/3 EV Step, -2 EV to +2 EV)
Metering mode: Multiple
LCD monitor: 2.7" TFT LCD
 (Approx. 230,000 dots) (field of view ratio about 100%)
Flash: Flash range: [ISO AUTO]
 Approx. 60 cm (1.97 feet) to 5.3 m (17.4 feet) (Wide)
Microphone: Monaural
Speaker: Monaural

Recording media: Built-in Memory (Approx. 40 MB)/SD Memory Card/SDHC Memory Card/SDXC Memory Card

Recording file format Still Picture: JPEG (based on "Design rule for Camera File system", based on "Exif 2.21" standard)/DPOF corresponding

Pictures with audio: JPEG (based on "Design rule for Camera File system", based on "Exif 2.21" standard)+"QuickTime"

Motion pictures with audio: AVCHD Lite/QuickTime Motion JPEG

Interface Digital: "USB 2.0" (High Speed)

Analog video/audio: NTSC/PAL composite (switched by menu), Audio line output (monaural)

Terminal [AV OUT/DIGITAL]: Dedicated jack (8 pin)
[HDMI]: MiniHDMI TypeC

Dimensions: Approx. 97.8 mm (W)×54.8 mm (H)×26 mm (D)
 [3.85" (W)×2.15" (H)×1.02" (D)]
 (excluding the projecting parts)

Mass (weight): Approx. 159 g/0.35 lb (with card and battery)
 Approx. 137 g/0.3 lb (excluding card and battery)

Operating temperature: 0 °C to 40 °C (32 °F to 104 °F)

Operating humidity: 10% to 80%

Battery Charger: Information for your safety

Input:	110 V to 240 V ~ 50/60 Hz, 0.2 A
Output:	4.2 V = 0.65 A (Battery charging)

Equipment mobility: Movable

Battery Pack (lithium-ion): Information for your safety

Voltage/capacity:	3.6 V/895 mAh
--------------------------	---------------

Note :
 *Above specification is for DMC-ZR3P.
 Some of the specification may differ depends on model suffix.

Motion pictures (Only "EB/EF/EG/EP/PR" models:)
 • Motion pictures (both AVCHD Lite and Motion JPEG) can be recorded continuously for up to 29 minutes 59 seconds.
 • Also, motion picture recorded continuously in 'MOTION JPEG' is up to 2GB.

(Except "EB/EF/EG/EP/PR" models:)
 • AVCHD Lite motion pictures can be recorded continuously for up to 13hours, 3 minutes 20 seconds.
 • Also, a maximum of approx.2GB of continuous motion picture can be recorded in Motion JPEG format.

5 Location of Controls and Components

Names of the Components

- 1 Flash
- 2 Lens
- 3 Self-timer indicator
AF assist lamp

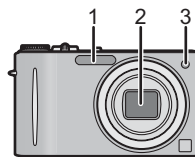

- 4 LCD monitor
- 5 [MENU/SET] button
- 6 [DISPLAY] button
- 7 [Q.MENU]/Delete button
- 8 [REC]/[PLAYBACK] selector switch
- 9 Motion picture button

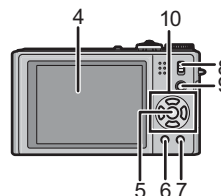

10 Cursor buttons

- (A): ▲/Exposure compensation/Auto Bracket/White Balance fine adjustment
- (B): ▼/Macro Mode AF Tracking
- (C): ◀/Self-timer button
- (D): ▶/Flash setting button

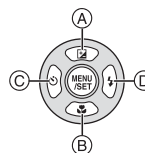

- 11 Camera ON/OFF switch
- 12 Zoom lever
- 13 Speaker
- 14 Microphone
- 15 Shutter button
- 16 Mode dial

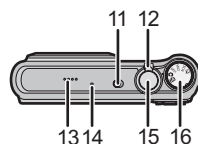

- 17 Hand strap eyelet
 - Be sure to attach the hand strap when using the camera to ensure that you will not drop it.
- 18 Lens barrel
- 19 [HDMI] socket
- 20 [AV OUT/DIGITAL] socket

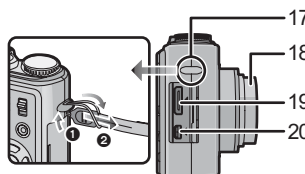

- 21 Tripod receptacle
 - When you use a tripod, make sure the tripod is stable when the camera is attached to it.
- 22 Card/Battery door
- 23 Release lever

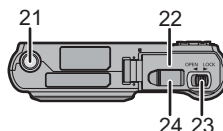

- 24 DC coupler cover
 - When using an AC adaptor, ensure that the Panasonic DC coupler and AC adaptor are used.
 - We recommend you use a battery with sufficient battery power or the AC adaptor when recording motion pictures.
 - If while recording motion pictures using the AC adaptor and the power supply is cut off due to a power outage or if the AC adaptor is disconnected etc., the motion picture being recorded will not be recorded.

Selecting the [REC] Mode

- 1 Turn the camera on.**
 - A [REC]/[PLAYBACK] selector switch
 - B Mode dial
- 2 Slide the [REC]/[PLAYBACK] selector switch to [📷].**
- 3 Switching the mode by rotating the mode dial.**

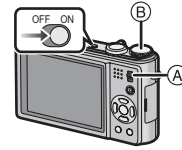

■ List of [REC] Modes

iA Intelligent Auto Mode

The subjects are recorded using settings automatically selected by the camera.

📷 Normal Picture Mode

The subjects are recorded using your own settings.

MS1 MS2 My Scene Mode

Pictures are taken using previously registered recording scenes.

SCN Scene Mode

This allows you to take pictures that match the scene being recorded.

📄 Clipboard Mode

Record as a memo.

Changing [REC MODE] and [REC QUALITY]

- 1** Select [REC MODE] from the [MOTION PICTURE] Mode menu, and press ►.



- 2** Press ▲/▼ to select the item and then press [MENU/SET].



Recording format	Features
[AVCHD Lite]	<ul style="list-style-type: none"> Select this format to record HD (high definition) video for playback on your HDTV using an HDMI connection. It can be played back as is by inserting the card into a device compatible with AVCHD. Refer to the instructions of the device used for details on compatibility. Use a card with SD Speed Class* with "Class 4" or higher.
[MOTION JPEG]	<ul style="list-style-type: none"> Select this format to record standard definition video for playback on your PC. It can be recorded using less storage when there is not much space left on the memory card or when you want to attach the motion picture to an e-mail. Use a card with SD Speed Class* with "Class 6" or higher.

*The SD Speed Class Rating is the speed standard for successive writes.

- 3** Press ▲/▼ to select [REC QUALITY] and then press ►.



- 4** Press ▲/▼ to select the item and then press [MENU/SET].

When [AVCHD Lite] is selected in step 2

	Item	Quality (bit rate)*1	fps	Aspect ratio
High quality ↑ ↓ Longer time	([SH])	1280×720 pixels Approx. 17 Mbps*2	60p (Sensor output is 30 fps)	16:9
	([H])	1280×720 pixels Approx. 13 Mbps*2		
	([L])	1280×720 pixels Approx. 9 Mbps*2		

*1 What is bit rate

This is the volume of data for a definite period of time, and the quality becomes higher when the number gets bigger. This unit is using the "VBR" recording method. "VBR" is an abbreviation of "Variable Bit Rate", and the bit rate (volume of data for definite period of time) is changed automatically depending on the subject to record. Therefore, the recording time is shortened when a subject with fast movement is recorded.

*2 What is Mbps

This is an abbreviation of "Megabit Per Second", and it represents the speed of transmission.

When [MOTION JPEG] is selected in step 2

	Item	Picture size	fps	Aspect ratio
High quality ↑ ↓ Longer time	([HD])	1280×720 pixels	30	16:9
	*3 ([WGA])	848×480 pixels		
	([VGA])	640×480 pixels		
	([QGA])	320×240 pixels	4:3	

*3 This item cannot be set in the Intelligent Auto Mode.

• With the [AVCHD Lite] or for [MOTION JPEG], high quality motion picture can be enjoyed on the TV by using the HDMI mini cable (optional). For details, see "Playing back on the TV with HDMI socket".

• It cannot be recorded to built-in memory except for the .

5 Press [MENU/SET] to close the menu.

- You can also press the shutter button halfway to close the menu.

Note

- The motion picture recording may stop in the middle when any of the following cards are used.
 - Cards on which recording and deleting have been repeated many times
 - Cards which have been formatted using a PC or other equipmentBefore taking pictures, format the card in the unit. Because formatting will delete all data recorded on the card, save important data beforehand on the computer.
- **Motion pictures recorded in [AVCHD Lite] or [MOTION JPEG] may be played back with poor picture or sound quality or playback may not be possible even when played back with equipment compatible with these formats. Also, the recording information may not be displayed properly. In this case, use this unit.**
For details on AVCHD compatible devices, refer to the support sites below.
<http://panasonic.jp/support/global/cs/dsc/>
(This Site is English only.)
- Motion picture recorded in [AVCHD Lite] does not comply with the "DCF/Exif", so some information will not display while playback.
- **Sound from motion pictures (When [REC MODE] is set to [MOTION JPEG]) or pictures with audio recorded by this camera cannot be played back by older models of Panasonic digital camera (LUMIX) launched before July 2008.**

About the Battery

- The camera has a function for distinguishing batteries which can be used safely. The dedicated battery supports this function. The only batteries suitable for use with this unit are genuine Panasonic products and batteries manufactured by other companies and certified by Panasonic. (Batteries which do not support this function cannot be used). Panasonic cannot in any way guarantee the quality, performance or safety of batteries which have been manufactured by other companies and are not genuine Panasonic products.

It has been found that counterfeit battery packs which look very similar to the genuine product are made available to purchase in some markets. Some of these battery packs are not adequately protected with internal protection to meet the requirements of appropriate safety standards. There is a possibility that these battery packs may lead to fire or explosion. Please be advised that we are not liable for any accident or failure occurring as a result of use of a counterfeit battery pack. To ensure that safe products are used we would recommend that a genuine Panasonic battery pack is used.

6 Service Mode

6.1. Error Code Memory Function

1. General description

This unit is equipped with history of error code memory function, and can be memorized 16 error codes in sequence from the latest. When the error is occurred more than 16, the oldest error is overwritten in sequence.

The error code is not memorized when the power supply is shut down forcibly (i.e., when the unit is powered on by the battery, the battery is pulled out) The error code is memorized to FLASH-ROM when the unit has just before powered off.

2. How to display

The error code can be displayed by ordering the following procedure:

• Preparation:

1. Attach the Battery or AC Adaptor with a DC coupler to the unit.

NOTE:

*Since this unit has built-in memory, it can be performed without inserting SD memory card.

*Set the mode dial to "Normal picture mode", to display the error code.

• Step 1. The temporary cancellation of "INITIAL SETTINGS":

Set the [REC]/[PLAYBACK] selector switch to "[REC] (Camera mark)".

While keep pressing "[UP] of Cursor button" and [DISPLAY] button simultaneously, turn the Power on.

• Step 2. Execute the error code display mode:

Press the "[LEFT] of Cursor button", [MENU/SET] button and [DISPLAY] button simultaneously.

The display is changed as shown below when the above buttons are pressed simultaneously.

Normal display → Error code display → Operation history display → Normal display →

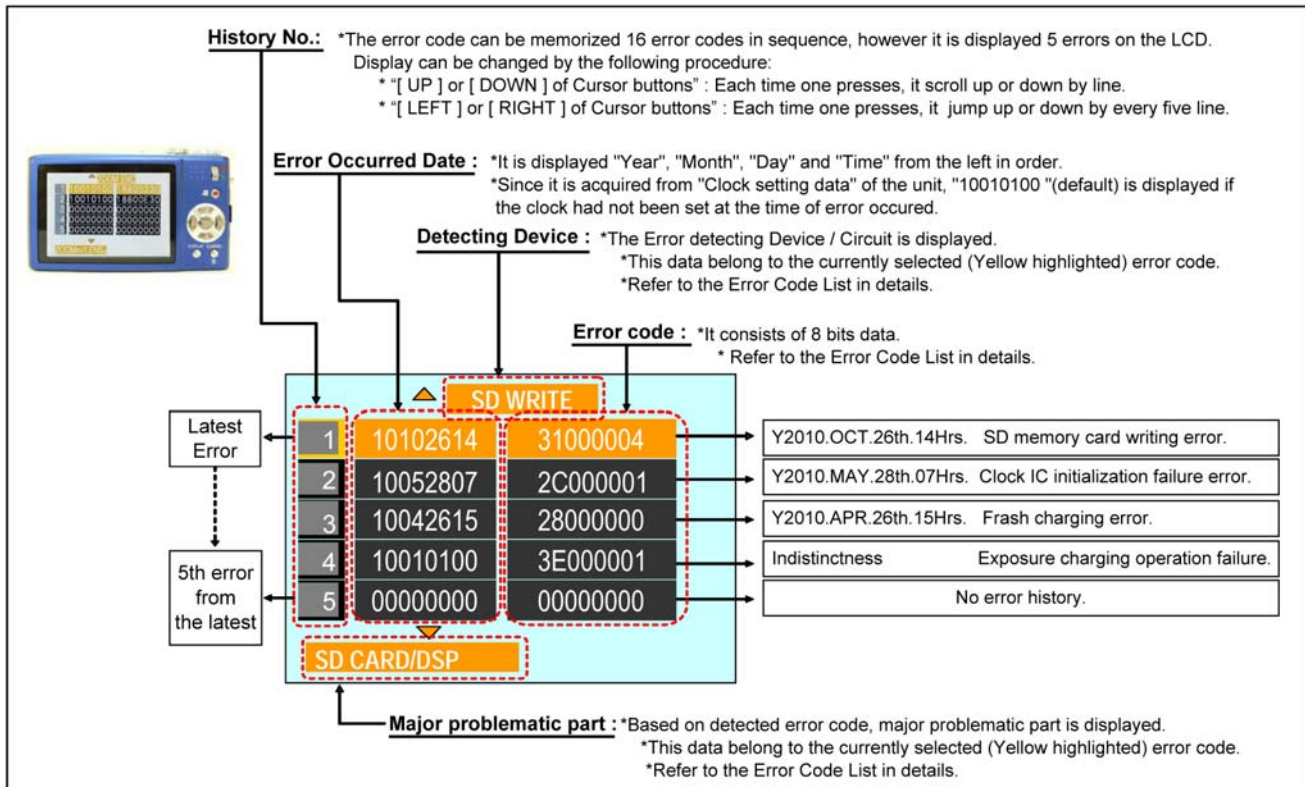

Example of Error Code Display

• 3. Error Code List

The error code consists of 8 bits data and it shows the following information.

Attribute	Main item	Sub item	Error code		Contents (Upper line)		Error Indication	
			High 4 bits	Low 4 bits	Problematic Part & Check point (Lower line)		Detecting device	Problematic Part/Circuit
LENS	Lens drive	OIS	18*0	1000	PSD (X) error. Hall element (X axis) position detect error in OIS unit. OIS Unit	OIS X	LENSu NG	
				2000	PSD (Y) error. Hall element (Y axis) position detect error in OIS unit. OIS Unit	OIS Y		
				3000	GYRO (X) error. Gyro (IC7301: X axis) detect error on Flash Top P.C.B. IC7301 (Gyro element) or IC6001 (VENUS HD2)	GYRO X	GYRO NG	
				4000	GYRO (Y) error. Gyro (IC9701: Y axis) detect error on Sub Operation FPC Unit IC9701 (Gyro element) or IC6001 (VENUS HD2)	GYRO Y		
				5000	MREF error (Reference voltage error). IC9101 (SYSTEM) or IC6001 (VENUS HD2)	OIS REF	LENSsd/DSP NG	
				6000	Drive voltage (X) error. LENS Unit, LENS flex breaks, IC6001 (VENUS HD2) AD value error, etc.	OISX REF	LENSu/LENS FPC	
				7000	Drive voltage (Y) error. LENS Unit, LENS flex breaks, IC6001 (VENUS HD2) AD value error, etc.	OISY REF		
		Zoom	0710	Collapsible barrel Low detect error (Collapsible barrel encoder always detects Low.) Mechanical lock, FP9002-(2) signal line or IC6001 (VENUS HD2)	ZOOM L	ZOOMm/LENSu		
				0720	Collapsible barrel High detect error (Collapsible barrel encoder always detects High.) Mechanical lock, FP9002-(2) signal line or IC6001 (VENUS HD2)		ZOOM H	
				0730	Zoom motor sensor error. Mechanical lock, FP9002-(32), (34) signal line or IC6001 (VENUS HD2)		ZOOM ENC	
				0740	Zoom motor sensor error. (During monitor mode.) Mechanical lock, FP9002-(32), (34) signal line or IC6001 (VENUS HD2)			
				0750	Zoom motor sensor error. (During monitor mode with slow speed.) Mechanical lock, FP9002-(32), (34) signal line or IC6001 (VENUS HD2)			
		Focus	0701	HP High detect error (Focus encoder always detects High, and not becomes Low) Mechanical lock, FP9002-(2) signal line or IC6001 (VENUS HD2)	FOCUS L	LENS FPC/DSP		
				0702	HP Low detect error (Focus encoder always detects Low, and not becomes High) Mechanical lock, FP9002-(2) signal line or IC6001 (VENUS HD2)		FOCUS H	
	Lens	18*1	0000	Power ON time out error. Lens drive system	LENS DRV	LENSu		
			18*2	0000	Power OFF time out error. Lens drive system			
	Adj. History	OIS	19*0	2000	OIS adj. Yaw direction amplitude error (small)	OIS ADJ	OIS ADJ	
				3000	OIS adj. Pitch direction amplitude error (small)			
				4000	OIS adj. Yaw direction amplitude error (large)			
				5000	OIS adj. Pitch direction amplitude error (large)			
				6000	OIS adj. MREF error			
				7000	OIS adj. time out error			
				8000	OIS adj. Yaw direction off set error			
				9000	OIS adj. Pitch direction off set error			
				A000	OIS adj. Yaw direction gain error			
				B000	OIS adj. Pitch direction gain error			
C000				OIS adj. Yaw direction position sensor error				
D000				OIS adj. Pitch direction position sensor error				
E000				OIS adj. other error				
HARD				VENUS A/D	Flash			28*0
	FLASH ROM (EEPROM Area)	FLASH ROM (EEPROM Area)	2B*0	0001	EEPROM read error IC6002 (FLASH ROM)	FROM RE	FROM	
				0002	EEPROM write error IC6002 (FLASH ROM)	FROM WR	FROM	
				0005	Firmware version up error Replace the firmware file in the SD memory card.	(No indication)	(No indication)	
				0008	SDRAM error			
	0009	SDRAM Mounting defective						
	SYSTEM	RTC	2C*0	0001	SYSTEM IC initialize failure error Communication between IC6001 (VENUS HD2) and IC9101 (SYSTEM)	SYS INIT	MAIN PCB	
SOFT	CPU	Reset	30*0	0001	NMI reset Non Mask-able Interrupt (30000001-30000007 are caused by factors)	NMI RST	MAIN PCB	
				0007				
	Card	Card	31*0	0001	Card logic error SD memory card data line or IC6001 (VENUS HD2)	SD CARD	SD CARD/DSP	
				0002	Card physical error SD memory card data line or IC6001 (VENUS HD2)			
				0004	Write error SD memory card data line or IC6001 (VENUS HD2)	SD WRITE		
				39*0	0005	Format error		INMEMORY
	CPU, ASIC hard	Stop	38*0	0001	Camera task finish process time out. Communication between Lens system and IC6001 (VENUS HD2)	LENS COM	LENSu/DSP	
				0002	Camera task invalid code error. IC6001 (VENUS HD2)	DSP	DSP	
				0100	File time out error in recording motion image IC6001 (VENUS HD2)			
				0200	File data cue send error in recording motion image IC6001 (VENUS HD2)			
				0300	Single or burst recording brake time out.			
				Memory area	3A*0	0008	USB work area partitioning failure USB dynamic memory securing failure when connecting	(No indication)
	Operation Zoom	Power on Zoom	3B*0	3C*0	0000	FLASHROM processing early period of camera during movement.	INIT	(No indication)
					0000	Inperfect zoom lens processing Zoom lens	ZOOM	ZOOMm/LENSu
35*0		0000	 FFFF	Software error (0-7bit : command, 8-15bit : status)	DSP	DSP		
				35*1	0000	Though record preprocessing is necessary, it is not called.	(No indication)	(No indication)
				35*2	0000	Though record preprocessing is necessary, it is not completed.	(No indication)	(No indication)

Important notice about "Error Code List"

1) About "*" indication:

The third digit from the left is different as follows.

- In case of 0 (example: 18001000)

When the third digit from the left shows "0", this error occurred under the condition of INITIAL SETTINGS has been completed.

It means that this error is occurred basically at user side.

- In case of 8 (example: 18801000)

When the third digit from the left shows "8", this error occurred under the condition of INITIAL SETTINGS has been released.

(Example; Factory assembling-line before unit shipment, Service mode etc.)

It means that this error is occurred at service side.

2) About "?" indication: ("18*0 0?01" to "18*0 0?50"):

The third digit from the right shows one of the hexadecimal ("0" to "F") character.

• 4. How to exit from Error Code display mode:

Simply, turn the power off. (Since Error code display mode is executed under the condition of temporary cancellation of "INITIAL SETTINGS", it wake up with normal condition when turn off the power.)

NOTE:

The error code can not be initialized.

6.2. ICS (Indication of additional Camera Settings when picture was taken) function

1. General description

This unit is equipped with ICS (ICS: Indication of additional Camera Settings when picture was taken) function by playing back the concerned picture on the LCD display.

(This function is achieved by utilizing "maker note" data stored in Exif data area of recorded picture file.)

To proceed failure diagnosis, use this ICS function together with "displaying the recorded picture with picture information" function.

NOTE:

- The ICS function operates with a picture which is only taken with the same model. (It may not be displayed when the picture was taken with other model.)
- Since Exif data is not available after the picture is edited by PC, the ICS function may not be activated.

2. How to display

The ICS data is displayed by ordering the following procedure:

• Preparation:

1. Attach the Battery or AC Adaptor with a DC coupler to the unit.

NOTE:

Set the mode dial to "Normal picture mode", to display the ICS data.

• Step 1. The temporary cancellation of "INITIAL SETTINGS":

Set the [REC]/[PLAYBACK] selector switch to "[REC] (Camera mark)".

While keep pressing "[UP] of Cursor button" and [DISPLAY] button simultaneously, turn the Power on.

• Step 2. Execute the ICS display mode:

Set the [REC]/[PLAYBACK] selector switch to [PLAYBACK].

Select the concerned picture by pressing the "[LEFT] and [RIGHT] of Cursor button".

Press the "[LEFT] of Cursor button", [MENU/SET] button and [DISPLAY] button simultaneously.

Press the [DISPLAY] button, 3 times.

The display condition is changed as shown below when the [DISPLAY] button is pressed.

Code display → Code + Picture display (1) → Code + Picture display (2) → ICS display → Code display

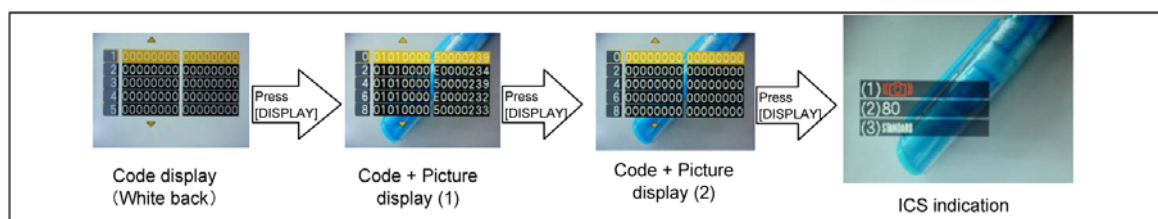

3. How to read

(1). Jitter alert was displayed or not:
 This part shows that the "Jitter alert" mark was displayed or not when the picture has just before been taken.
 +.With "Jitter alert" mark : The "Jitter alert" mark was displayed.
 +.Without "Jitter alert" mark: The "Jitter alert" mark was not displayed.
 [About "Jitter alert" mark]
 Due to lacking the enough light amount etc, shooting condition prone to make a "hand jitter", the "Jitter alert" mark is displayed.
 [Reference Guide]
 (Applicable settings : Normal picture mode, ISO100, WIDE edge, Flash OFF)
 +.The "Jitter alert" mark is displayed when the shutter speed is 1/15th and below.

(2). ISO Sensitivity Setting condition:
 This part shows that the "ISO Sensitivity" setting condition when the picture had been taken.
 (Note: The [i ISO] is displayed when the "Intelligent ISO" was selected.)
 For instance, when the recorded picture information shows [ISO80], it can be confirmed the ISO setting condition : [AUTO], [INTELLIGENT ISO] or [ISO 80](Fixed: set by user).
 [Point for Confirmation]
 *The symptom is "Picture with "hand jitter". Subject is not clearly stopped." in darker scene, does the picture was taken with lower ISO setting mode?
 *The symptom is "Noisy picture. Rough picture image" in brighter scene, does the picture was taken with higher ISO setting mode?

(3). Color mode Setting condition:
 This part shows that the "Color mode" setting condition when the picture had been taken.
 [Point for Confirmation]
 *The symptom is "Color is strange. The picture is bluish (Yellowish) ", does the picture was taken with [SEPIA] / [COOL] / [WARM] settings?
 NOTE: As for the symptom related with the color, confirm the picture information which is displayed in normal playback screen as well.
 (In normal playback screen, the setting condition of "White balance" and "WB Adjustment "can be confirmed.)

Normal playback screen
(Recorded picture with information)



*In playback mode, the picture information is displayed when pressing the [DISPLAY] button (It can be confirmed at user as well.)
 *Use this indication together with ICS function

[ICS display (Sample)]

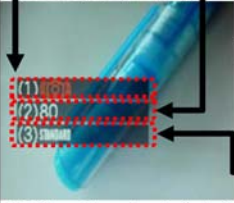

(1). Jitter alert mark : [Indicated]
 (2). ISO sens. setting : ISO80 (Fixed)
 (3). Color mode setting: Standard

[Reference Guide : Settings "When taking picture"]

<ISO SENSITIVITY>
 *This allows the sensitivity to light (ISO sensitivity) to be set. Setting to a higher figure enables pictures to be taken even in dark places without the resulting pictures coming out dark.
 *In this unit, it can be set one of the [AUTO], [80], [100], [200], [400], [800] and [1600] in "Normal shooting" mode.
 (The ISO sensitivity setting is not available when the [INTELLIGENT ISO] is being used.)
 *When setting to [AUTO], the ISO sensitivity is automatically adjusted to a maximum of [ISO400] according to the brightness.
 (It can be adjusted to a maximum of [ISO1600] when using the flash.)
 *To avoid picture noise, we recommend that you either reduce the ISO sensitivity level or set [COLOR MODE] to [NATURAL], and then take pictures.

ISO sensitivity	80	←————→	1600
Recording location (recommended)	When it is light (outdoors)		When it is dark
Shutter speed	Slow		Fast
Noise	Less		Increased

<COLOR MODE>
 *Using these modes, the pictures can be made sharper or softer, the colors of the pictures can be turned into sepia colors or other color effects can be achieved.
 *In this unit, it can be set one of the following effects in "Normal shooting" mode.

[STANDARD]	: This is the standard setting.	[B/W]	: The picture becomes black and white.
[Happy]*1	: Image with enhanced brightness and vividness.	[SEPIA]	: The picture becomes sepia.
[NATURAL]*2	: The picture becomes softer.	[COOL]*2	: The picture becomes bluish.
[VIVID]*2	: The picture becomes sharper.	[WARM]*2	: The picture becomes reddish.

*1 This can be set only when Intelligent Auto Mode is set.
 *2 This can be set only during Normal Picture Mode or Motion Picture Mode.
 *When you take pictures in dark places, noise may become visible. To avoid noise, we recommend setting to [NATURAL].



4. How to exit:

Simply, turn the power off. (Since ICS function is executed under the condition of temporary cancellation of "INITIAL SETTINGS", it wake up with normal condition when turn off the power.)

7 Service Fixture & Tools

7.1. Service Fixture and Tools

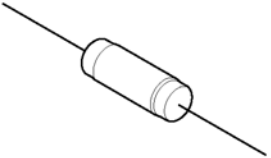
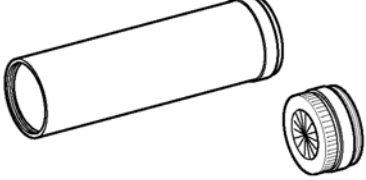
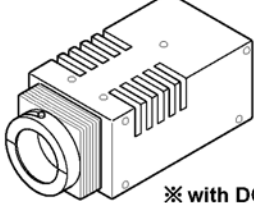
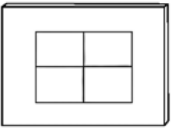
The following Service Fixture and tools are used for checking and servicing this unit.

Resistor for Discharging ERG5SJ102	Infinity Lens (with Focus Chart) VFK1164TCM02	LIGHT BOX VFK1164TDVLB
 An equivalent type of Resistor may be used.	 * VFK1164TCM03 can be used. * RFKZ0422 can be used.	 ※ with DC Cable * RFKZ0523 can be used.
TR Chart RFKZ0443	Lens Cleaning Kit (BK) VFK1900BK	Grease (for lens) RFKZ0472
	 * Only supplied as 10 set/box.	

7.2. When Replacing the Main P.C.B.

After replacing the MAIN P.C.B., be sure to achieve adjustment.

The adjustment instruction is available at “software download” on the “Support Information from NDBG/VDBG-AVC” web-site in “TSN system”, together with Maintenance software.

7.3. Service Position

This Service Position is used for checking and replacing parts. Use the following Extension cables for servicing.

Table S1 Extension Cable List

No.	Parts No.	Connection	Form
1	RFKZ0477	FP9001 (MAIN) - CCD UNIT	45PIN 0.3 FFC
2	RFKZ0416	FP9002 (MAIN) - LENS UNIT	41PIN 0.3 FFC
3	RFKZ0416	FP9003 (MAIN) - LCD UNIT	41PIN 0.3 FFC
4	RFKZ0545	PP9001 (MAIN) - PS8001 (FLASH TOP)	34PIN B to B

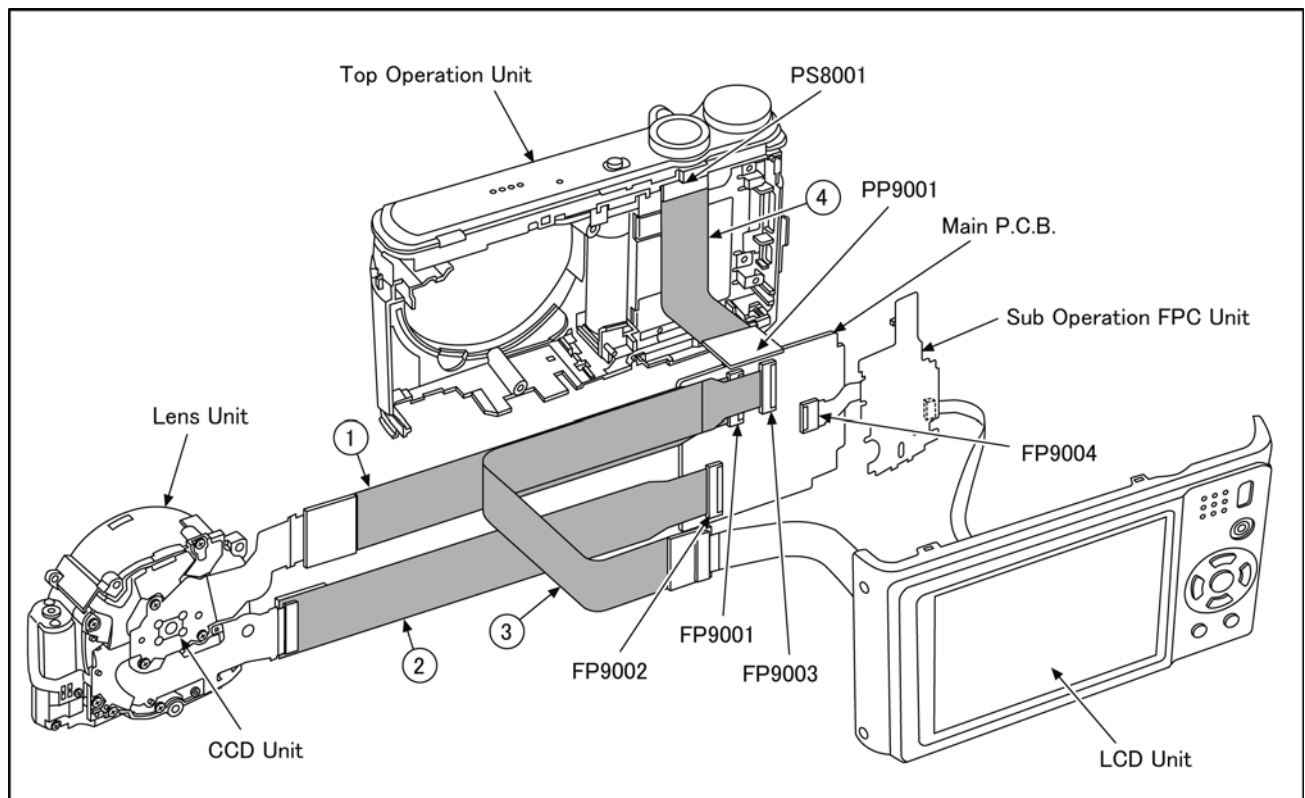

CAUTION-1. (When servicing FLASH TOP P.C.B.)

1. Be sure to discharge the capacitor on FLASH TOP P.C.B..
Refer to “HOW TO DISCHARGE THE CAPACITOR ON FLASH TOP P.C.B.”.
The capacitor voltage is not lowered soon even if the AC Cord is unplugged or the battery is removed.
2. Be careful of the high voltage circuit on FLASH TOP P.C.B..
3. DO NOT allow other parts to touch the high voltage circuit on FLASH TOP P.C.B..

8 Disassembly and Assembly Instructions

8.1. Disassembly Flow Chart

This is a disassembling chart.

When assembling, perform this chart conversely.

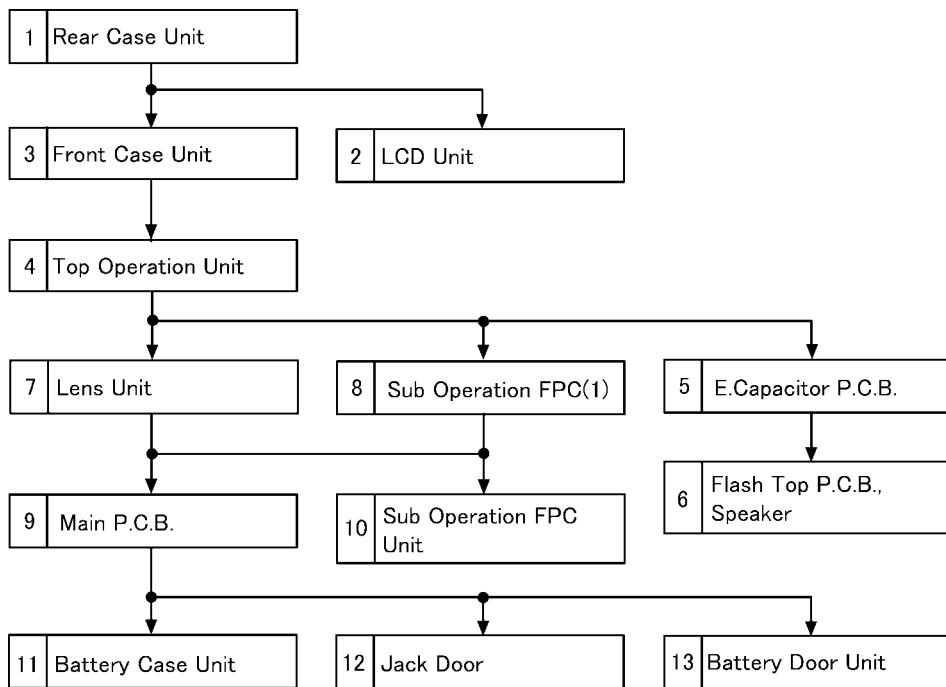

8.2. P.C.B. Location

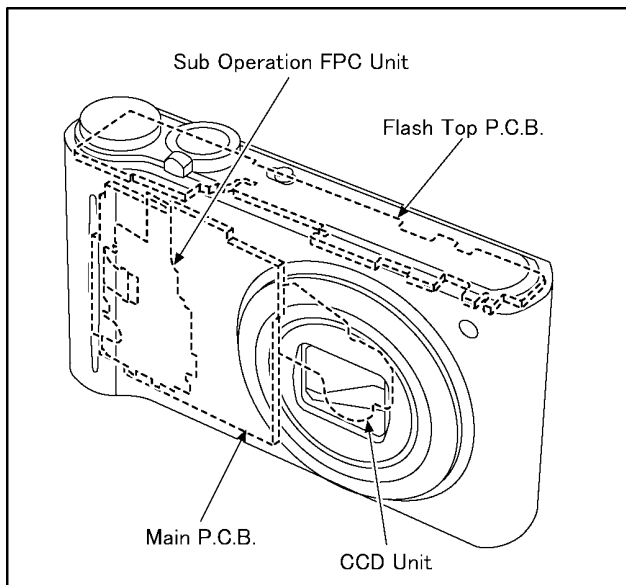

8.3. Disassembly Procedure

No.	Item	Fig	Removal			
1	Rear Case Unit	(Fig.D1)	Card			
			Battery			
			6 Screws (A)			
			1 Screw (B)			
			FP9003(Flex)			
			FP9501(Flex)			
			Rear Case Unit			
2	LCD Unit	(Fig.D2)	4 Locking tabs			
			LCD Unit			
3	Front Case Unit	(Fig.D3)	1 Screw (C)			
			3 Screws (D)			
			2 Locking tabs			
			Front Case Unit			
4	Top Operation Unit	(Fig.D4)	PS8001(Connector)			
			Strap Holder			
			Top Operation Unit			
5	E.Capacitor P.C.B.	(Fig.D5)	1 Screw (E)			
			1 Locking tab			
			2 Ribs			
		(Fig.D6)	1 Locking tab			
			Capacitor P.C.B. Holder			
			E.Capacitor P.C.B.			
6	Flash Top P.C.B. Speaker	(Fig.D7)	2 Locking tabs			
			AF Panel Light			
			2 Screws (F)			
			Top Plate (R)			
			3 Locking tabs			
			Mic Damper			
			Power Knob Base			
			Power Knob			
			Flash Top P.C.B.			
			Speaker			
			(Fig.D8)	NOTE: (When Installing)		
			7	Lens Unit	(Fig.D9)	3 Screws (G)
						1 Locking tab
Frame Plate						
Tripod Fixing Plate						
FP9001(Flex)						
FP9002(Flex)						
Lens Unit						
8	Sub Operation FPC(1)	(Fig.D10)				1 Screw (H)
						2 Ribs
						FP9004(Flex)
9	Main P.C.B.	(Fig.D11)	1 Rib			
			Main P.C.B.			
10	Sub Operation FPC Unit	(Fig.D12)	4 Locking tabs			
			REC/PLAYBACK Selector Knob			
			(Fig.D13)	2 Pins		
				5 Locking tabs		
		2 Pins				
		4 Locking tabs				
					SW Plate	
					SW P.C.B. Base	
Sub Operation FPC Unit						
11	Battery Case Unit	(Fig.D14)	3 Locking tabs			
			Battery Out Spring			
			Battery Case Unit			
12	Jack Door	(Fig.D15)	Jack Door Shaft			
			Jack Door			
13	Battery Door Unit	(Fig.D16)	Battery Door Shaft			
			Battery Door Spring			
			Battery Door Unit			

8.3.1. Removal of the Rear Case Unit

NOTE:
When servicing and reassembling, remove the card and battery from the unit.

- Card
- Battery
- Screw(A) × 6
- Screw(B) × 1
- FP9003(Flex)
- FP9501(Flex)

NOTE: (When Replacing)

- When remove the flex, pull up the locking tab in the direction of arrow (1), and then remove the flex in the direction of arrow (2).

NOTE: (When Installing)

- Open the Jack door before installing the rear case unit. (to prevent damaged)

Screw(A)	Screw(B)
2.5mm	3.3mm
(S/N): SILVER	(S/N): SILVER
(K/A/R/T): BLACK	(K/A/R/T): BLACK

(Fig.D1)

8.3.2. Removal of the LCD Unit

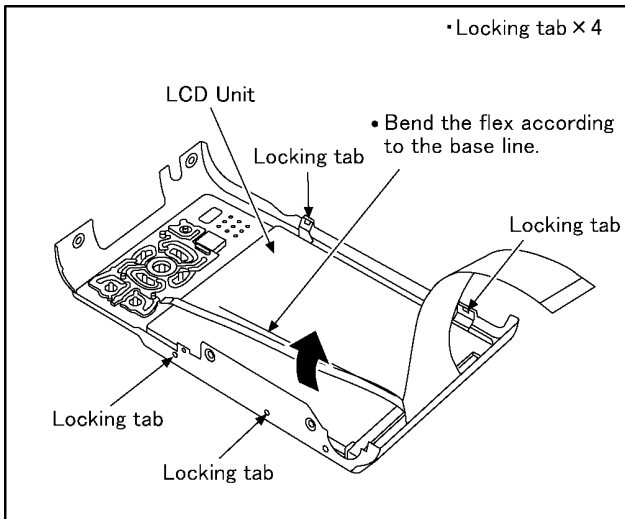

(Fig.D2)

8.3.3. Removal of the Front Case Unit

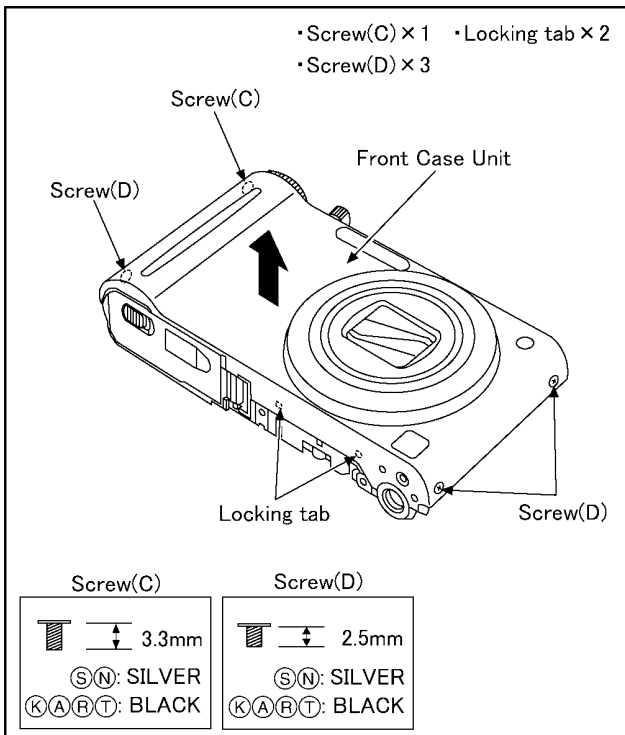

(Fig.D3)

8.3.4. Removal of the Top Operation Unit

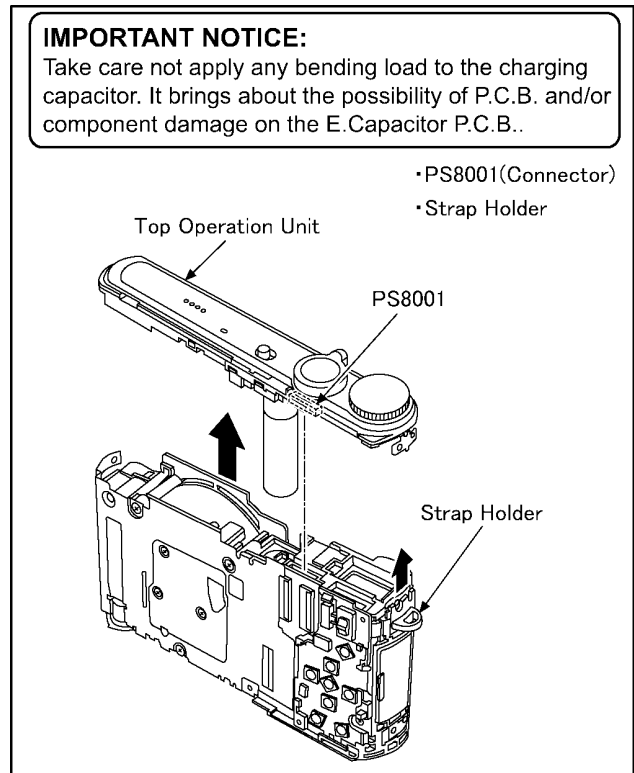

(Fig.D4)

8.3.5. Removal of the E.Capacitor P.C.B.

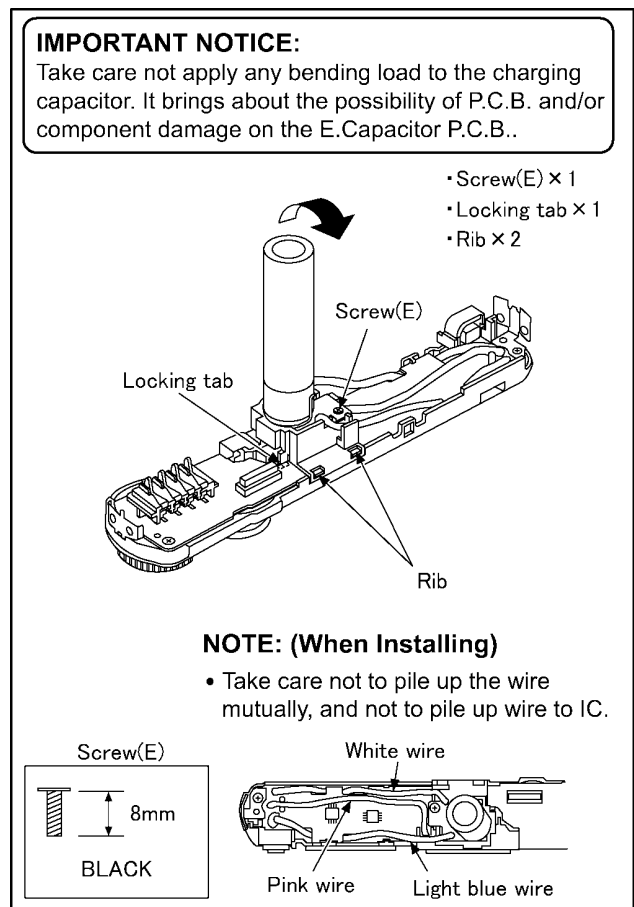

(Fig.D5)

IMPORTANT NOTICE:

Take care not apply any bending load to the charging capacitor. It brings about the possibility of P.C.B. and/or component damage on the E.Capacitor P.C.B..

- Locking tab × 1
- Capacitor P.C.B. Holder

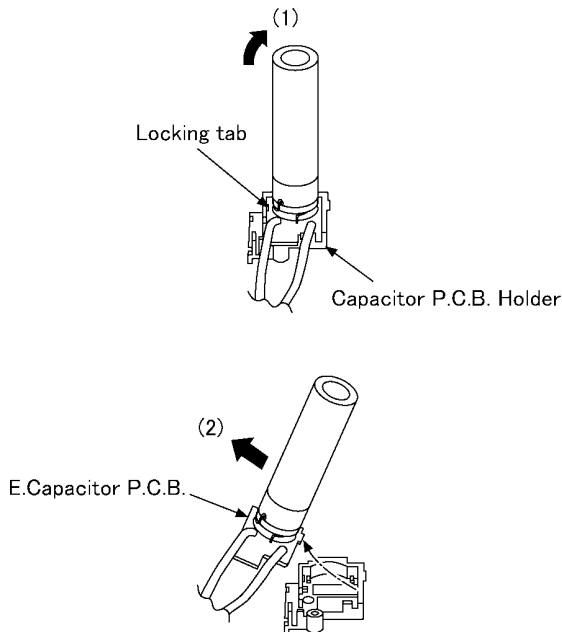

NOTE: (When Replacing)

- When remove the e.capacitor P.C.B., remove the 1 locking tab and pull up the e.capacitor P.C.B. in the direction of arrow (1), and then remove the e.capacitor P.C.B. in the direction of arrow (2).

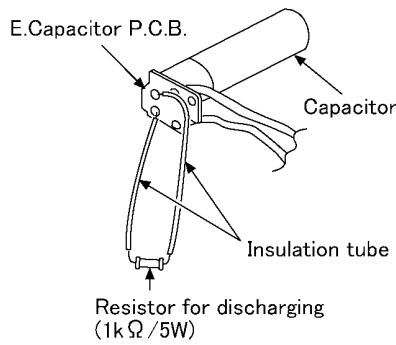

CAUTION

Be sure to discharge the capacitor on E.Capacitor P.C.B. before disassembling.

1. Remove the E.Capacitor P.C.B..
2. Put the insulation tube on the lead part of resistor (ERG5SJ102: 1kΩ/5W).
3. Put the resistor between both terminals of capacitor unit for approx. 5 seconds.

(Fig.D6)

8.3.6. Removal of the Flash Top P.C.B. and Speaker

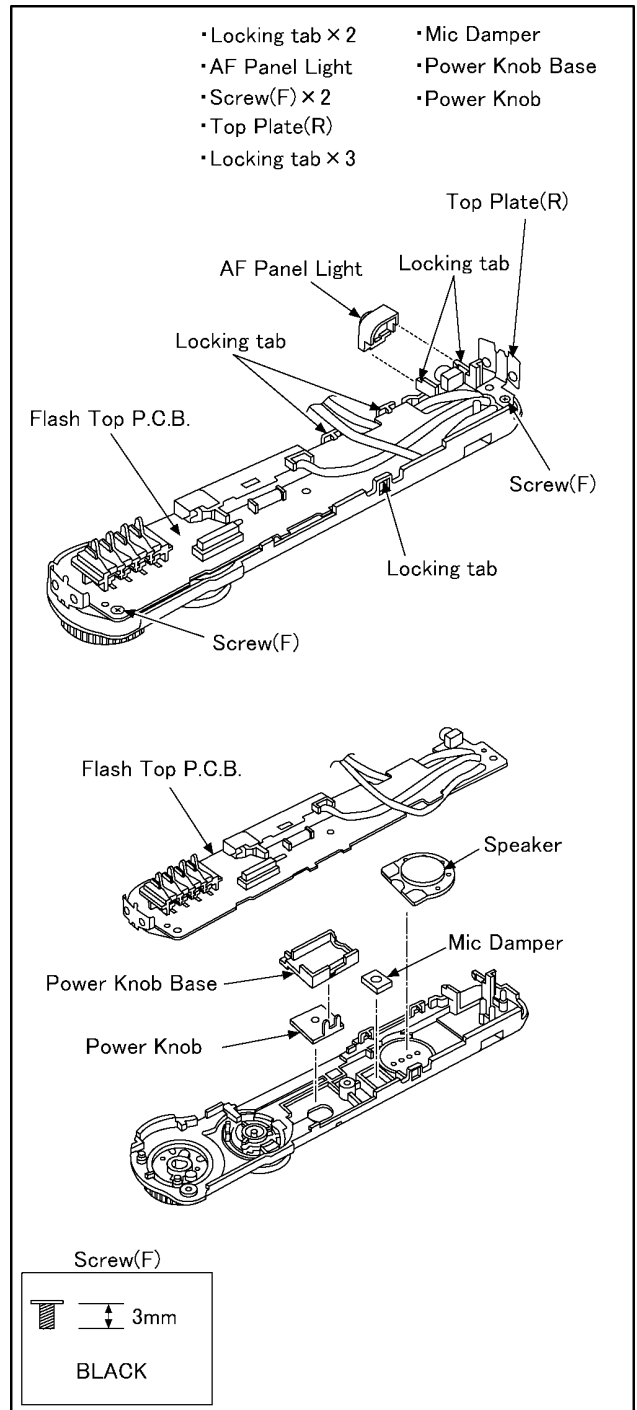

(Fig.D7)

NOTE: (When Installing)

- Align the convex of power switch and power knob.
- Align the convex of mode switch (D cut) and mode knob (D cut).

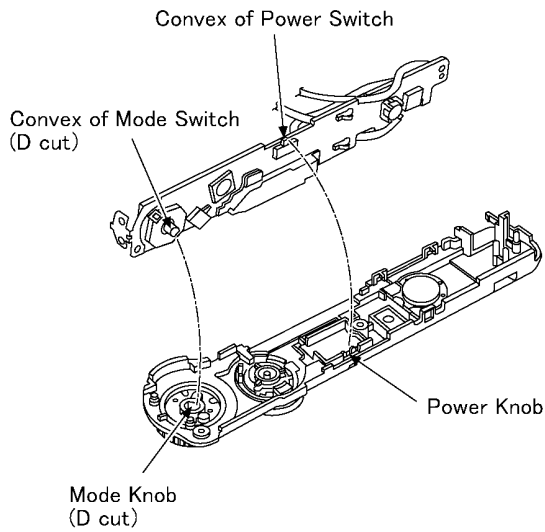

(Fig.D8)

8.3.7. Removal of the Lens Unit

- Screw(G) × 3
- Locking tab × 1
- Frame Plate
- Tripod Fixing Plate
- FP9001(Flex)
- FP9002(Flex)

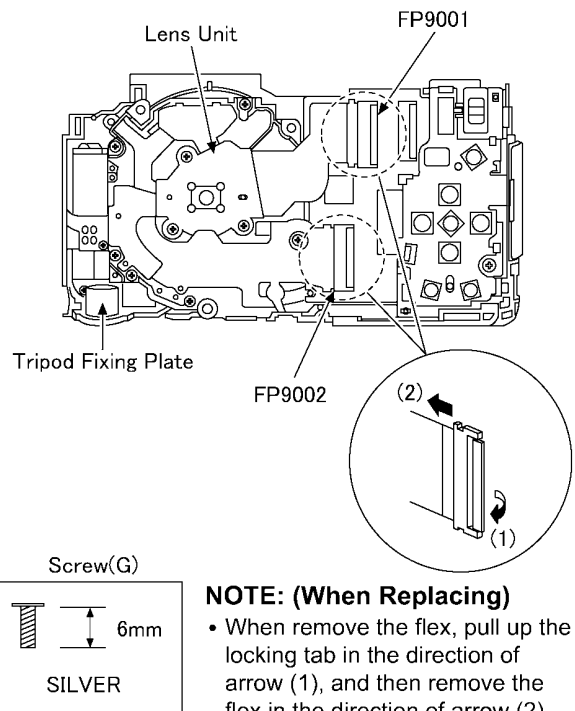
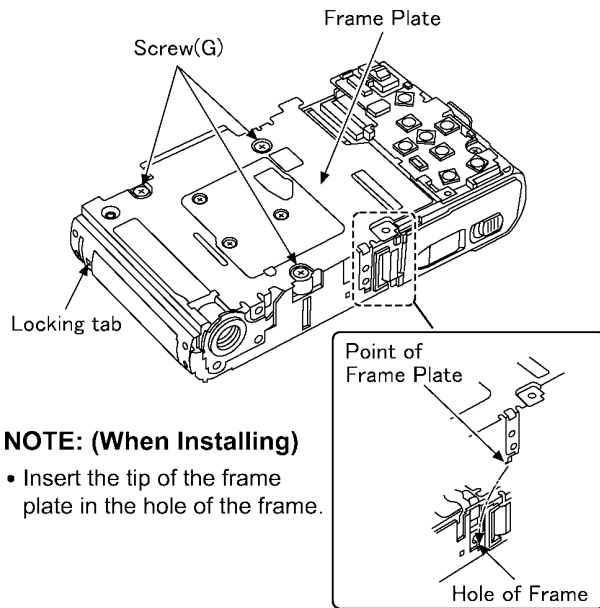

(Fig.D9)

8.3.8. Removal of the Sub Operation FPC(1)

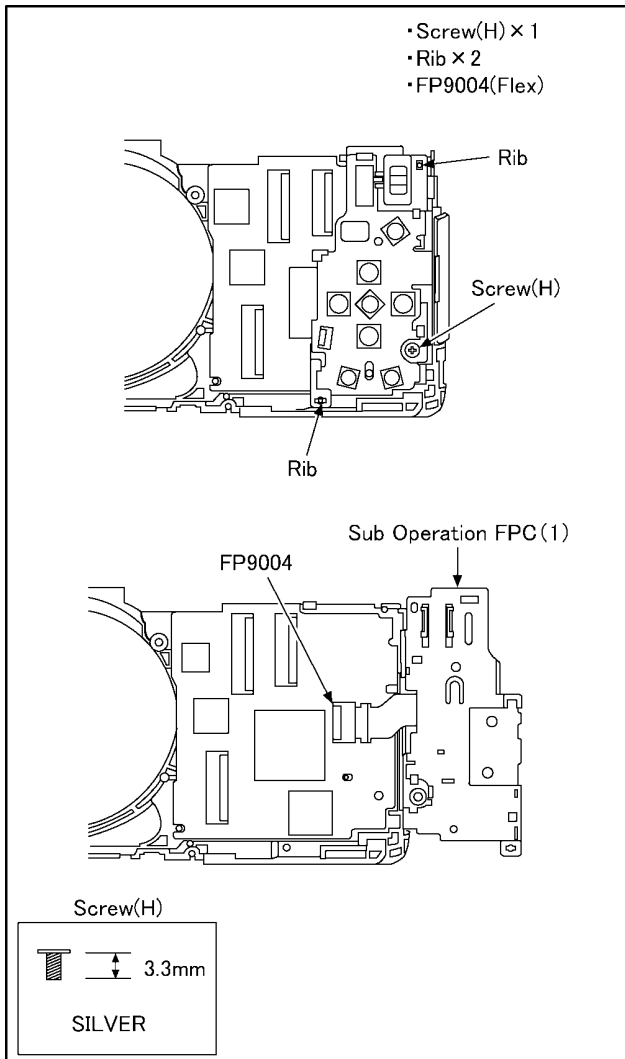

(Fig.D10)

8.3.9. Removal of the Main P.C.B.

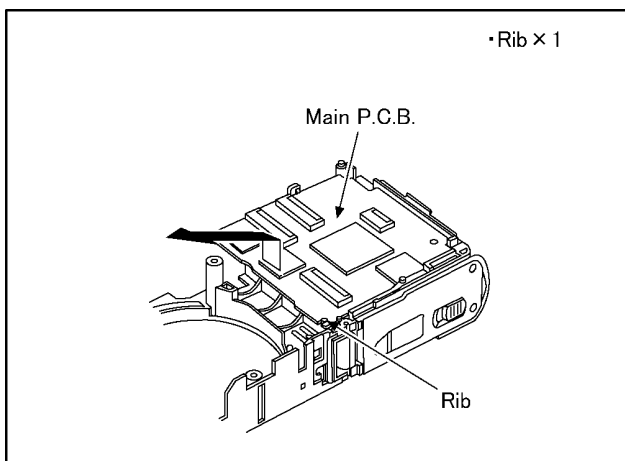

(Fig.D11)

8.3.10. Removal of the Sub Operation FPC Unit

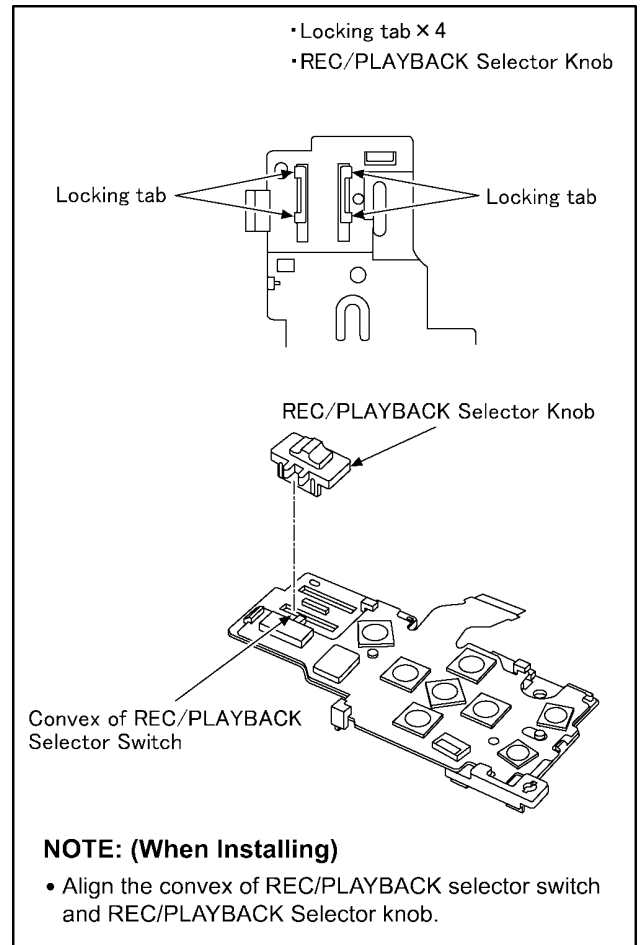

(Fig.D12)

8.3.11. Removal of the Battery Case Unit

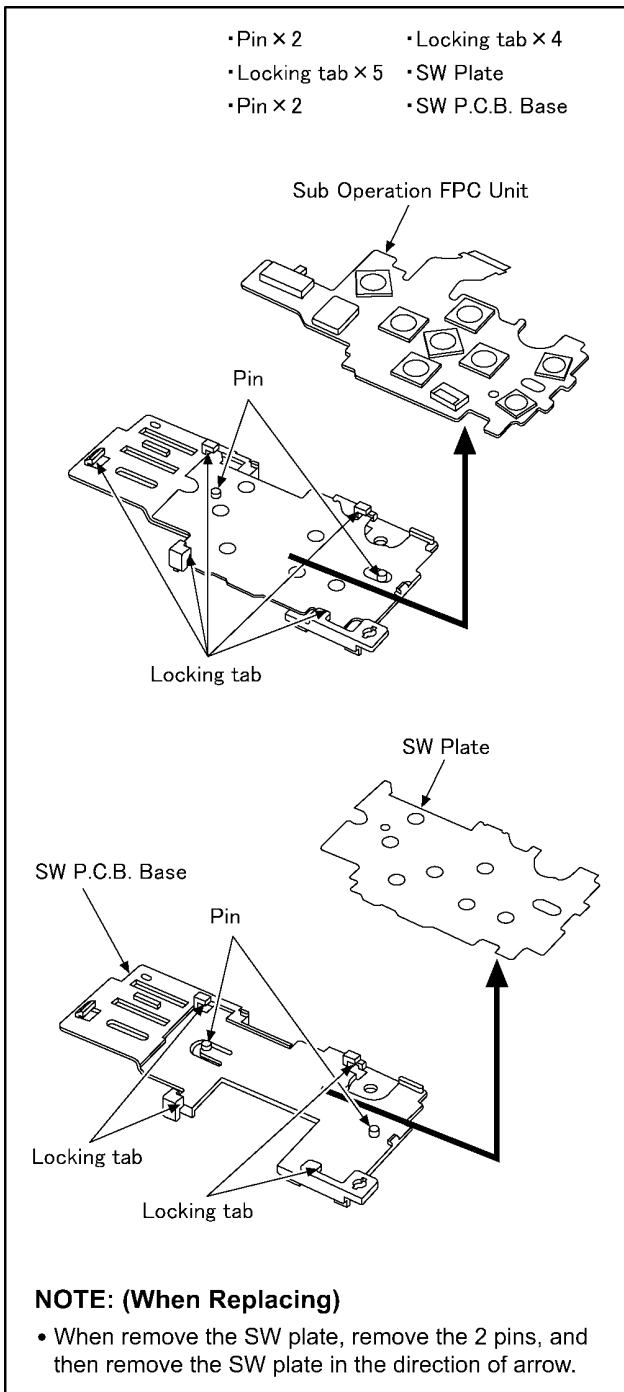

(Fig.D13)

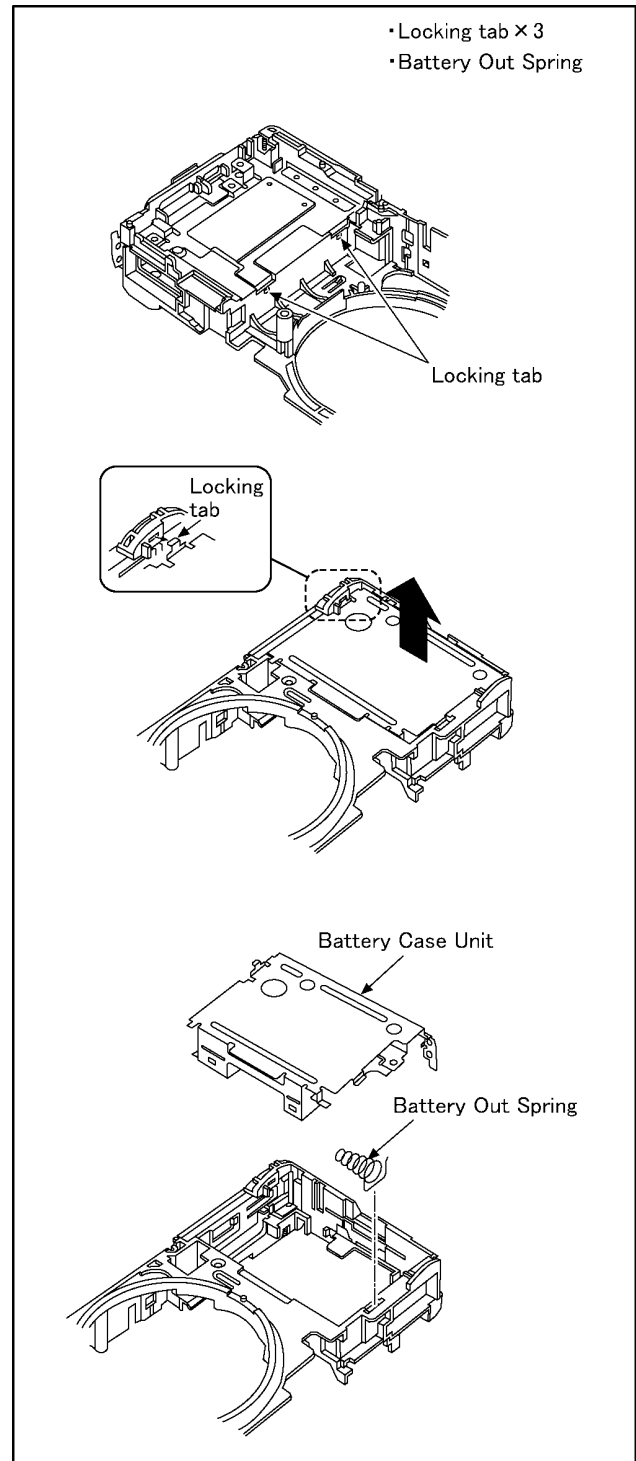

(Fig.D14)

8.3.12. Removal of the Jack Door

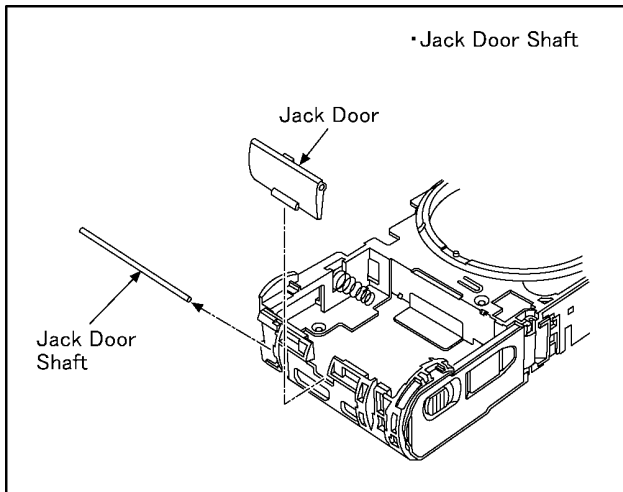

(Fig.D15)

8.3.13. Removal of the Battery Door Unit

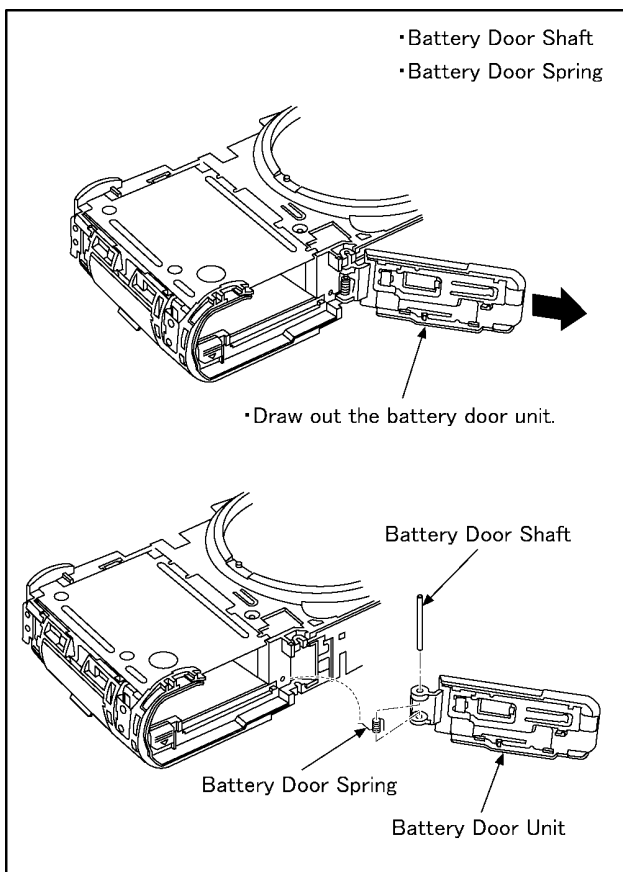

(Fig.D16)

NOTE: (When Installing)

Make sure to confirm the following points when installing:

- The Screw is tightened enough.
- Installing conditions are fine. (No distortion, no abnormal-space.)
- No dust and/or dirt on Lens surfaces.
- LCD image is fine. (No dust and dirt on it, and no gradient images.)

8.4. Lens Disassembly Procedure

Precaution:

1. Do not remove the CCD when disassembling or re-assembling the lens in order to maintain it clean.
When remove it, refer to item "8.6."
2. Keep dust or dirt away from the lens.
3. To remove dirt or dust from the lens, blow with dry air.
4. Do not touch the lens surface.
5. Apply grease (RFKZ0472) as shown on "THE APPLICATION OF GREASE METHOD" in the figure.
6. Apply a light coat of grease using an object similar to a toothpick.
7. The fixed frame unit, drive frame unit and penetration cam frame should be replaced as a unit.

8.4.1. Removal of the Zoom Motor and Lens FPC Unit

1. Remove the 7 solders (A).
2. Remove the 1 lock.
3. Unscrew the 2 screws (A).
4. Remove the zoom motor to the direction of arrow (1).
5. Remove the 4 solders (B).

6. Unscrew the 1 screw (B).
7. Remove the photo sensor.
8. Remove the 16 solders (C).
9. Remove the 5 locks.
10. Remove the lens FPC unit to the direction of arrow (2).

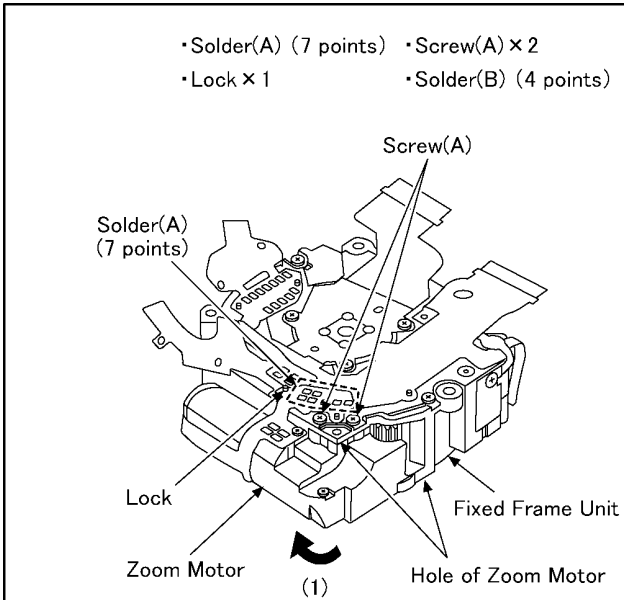

NOTE: (When Installing)

- Align the convex of fixed frame unit and hole of zoom motor, and then install them.

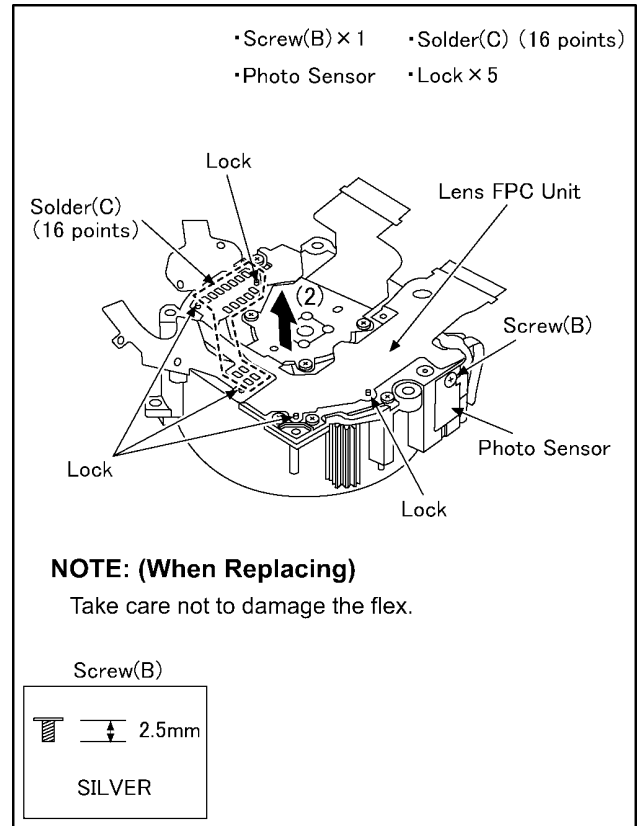
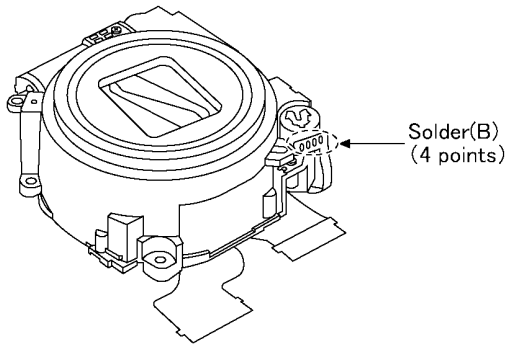

8.4.2. Removal of the Master Flange Unit

1. Unscrew the 4 screws (C).

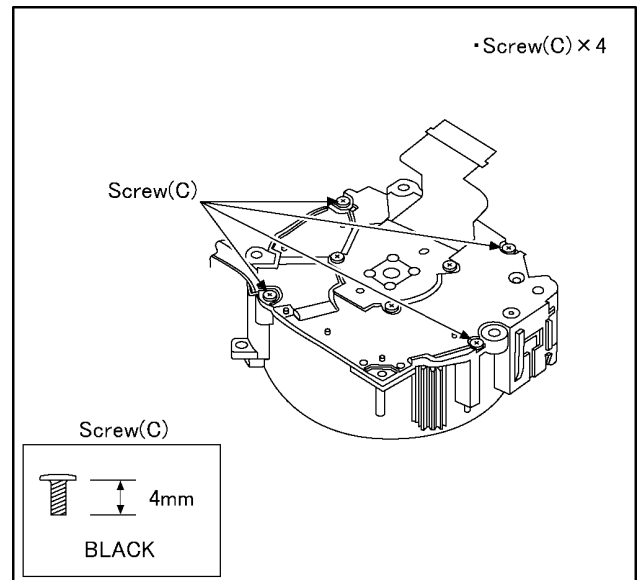

2. Remove the master flange unit.

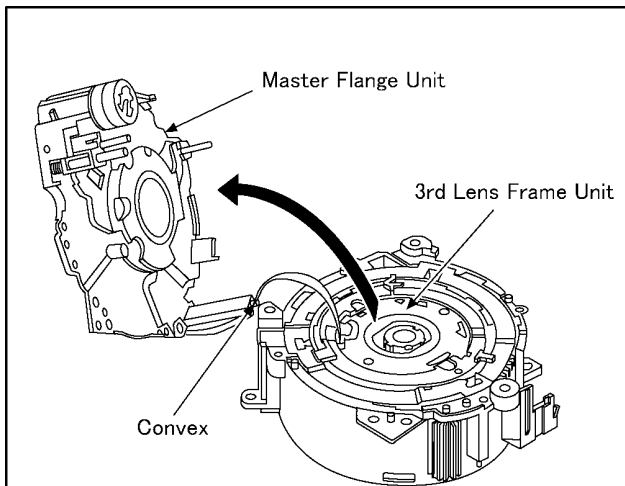

NOTE:(When Replacing)

- Remove the flex of 3rd lens frame unit from convex of the master flange unit.
- Take care not to damage the flex.

NOTE:(When Installing)

- Refer to "THE APPLICATION OF GREASE METHOD" when installing the master flange unit.

8.4.3. Removal of the 1st Lens Frame Unit/2nd Lens Frame Unit/Both Sides Cam Frame/2nd 3rd Direct Frame/3rd Lens Frame Unit

1. Push the both sides cam frame from the lens front side in the direction of arrow, and then remove the unit of 1st lens frame unit/2nd lens frame unit/both sides cam frame/2nd 3rd direct frame/3rd lens frame unit from the fixed frame unit/drive frame unit/penetration cam frame/1st direct frame unit.

■ CAUTION

- Fixed Frame Unit/Drive Frame Unit/Penetration Cam Frame cannot exchange single part because of original performance maintenance.
Necessary unit exchange by using the repair parts (Fix/Drive/Cam Frame Unit).

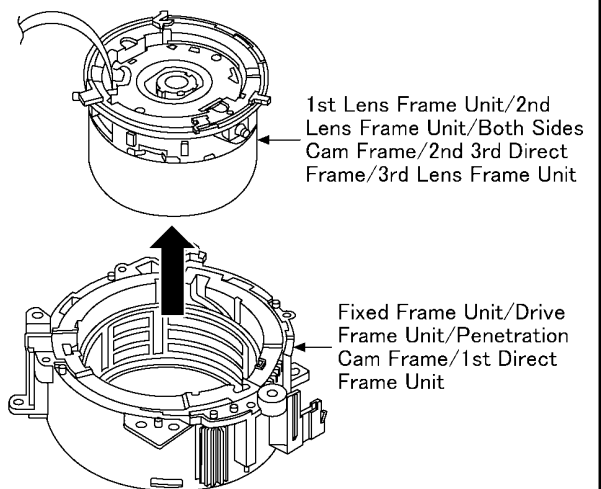

NOTE: (When Replacing)

- Take care not to damage the flex.
- When lift the 1st lens frame unit/2nd lens frame unit/both sides cam frame/2nd 3rd direct frame/3rd lens frame unit, take care not to put fingerprint of the lens.

8.4.4. Removal of the 2nd Lens Frame Unit/Both Sides Cam Frame/2nd 3rd Direct Frame/3rd Lens Frame Unit

1. Turn the 2nd lens frame unit/both sides cam frame/2nd 3rd direct frame/3rd lens frame unit in the direction of the arrow (1) fully, and then remove them in the direction of the arrow (2).

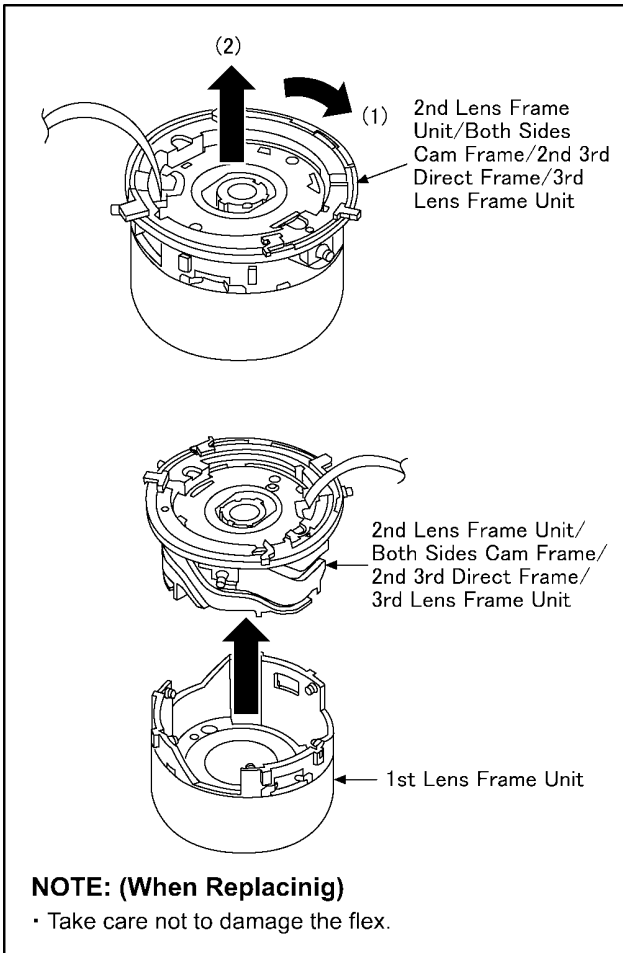

8.4.5. Removal of the 3rd Lens Frame Unit

1. Remove the 3rd lens frame unit in the direction of the arrow.

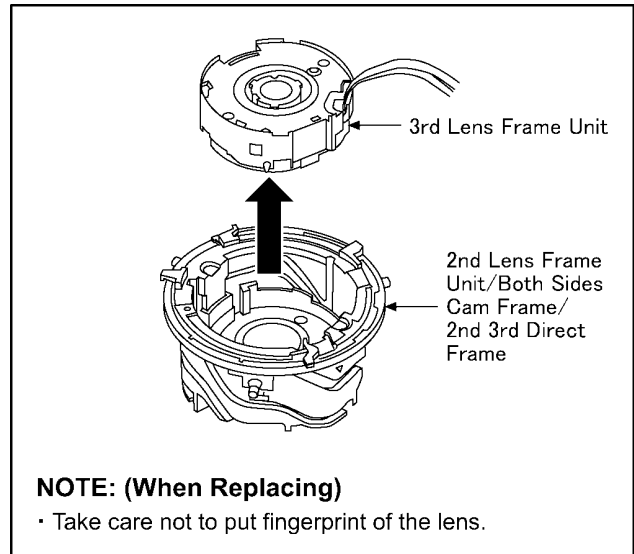

8.4.6. Removal of the 2nd 3rd Direct Frame

1. Remove the 2nd 3rd direct frame in the direction of the arrow.

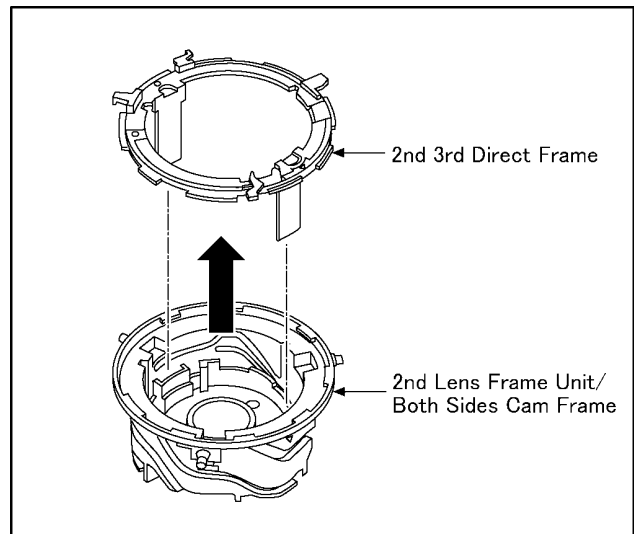

8.4.7. Removal of the 2nd Lens Frame Unit

1. Turn the 2nd lens frame unit in the direction of the arrow (1) a little, and then remove it in the direction of the arrow (2).

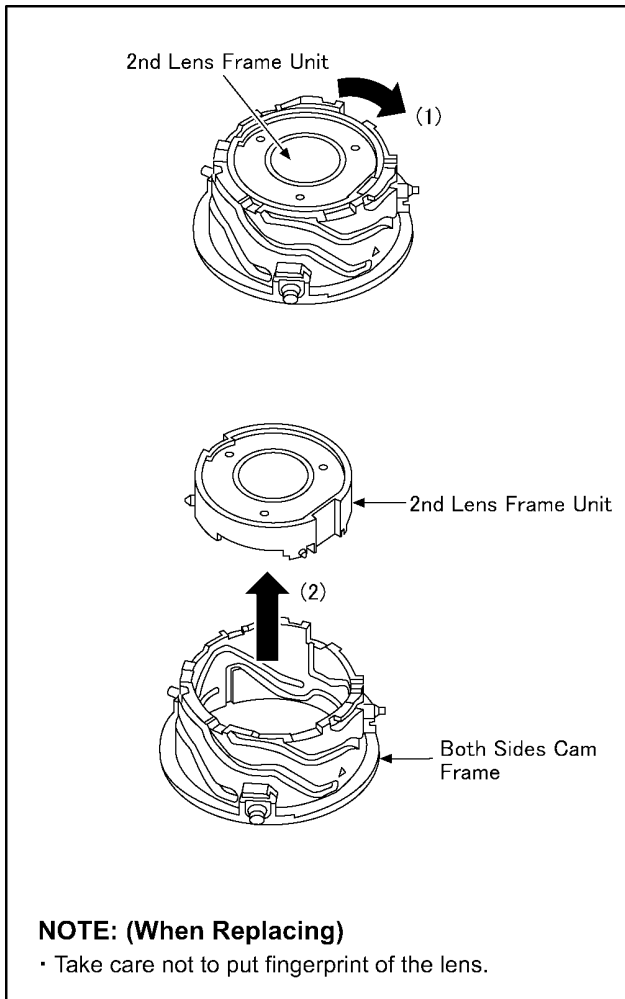

8.4.8. Removal of the 1st Direct Frame Unit

1. Remove the 1st direct frame unit in the direction of the arrow.

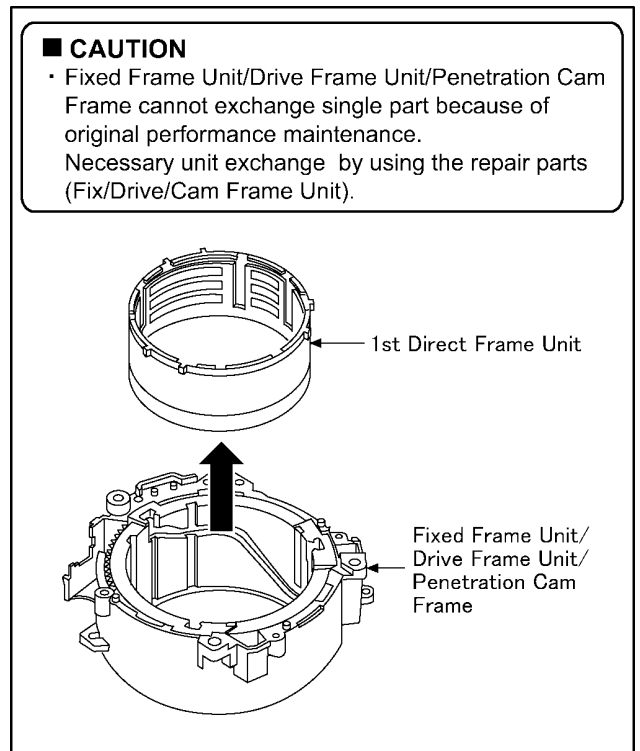

8.5. Assembly Procedure for the Lens

8.5.1. Phase alignment of the Penetration Cam Frame and Drive Frame Unit

- Insert the shading sheet to drive frame unit. (When insert the shading sheet, so that the luster side facing to subject side.)
- Align the Δ mark of penetration cam frame and the Δ mark of drive frame unit, and then install the penetration cam frame to drive frame unit.

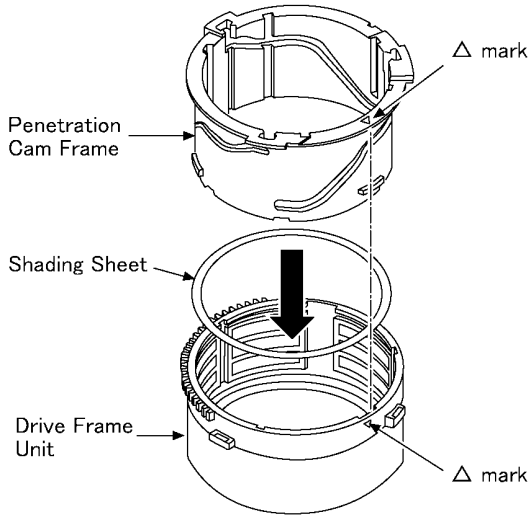

- Align the phase of the groove of penetration cam frame and the groove of drive frame unit (3 points).

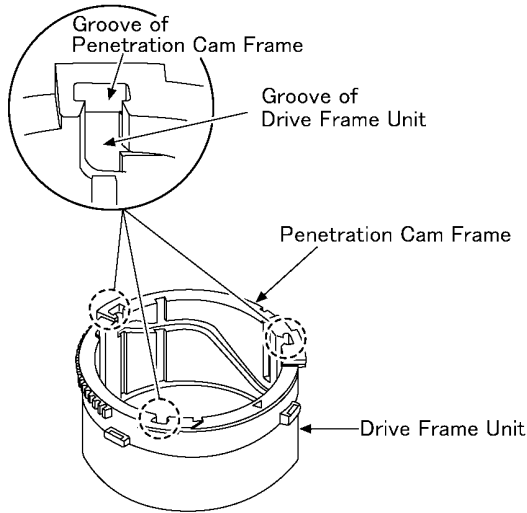

8.5.2. Phase alignment of the Drive Frame Unit/Penetration Cam Frame and Fixed Frame Unit

- Align the Δ mark of drive frame unit/penetration cam frame and the Δ mark of fixed frame unit, and then install the drive frame unit/penetration cam frame to fixed frame unit.

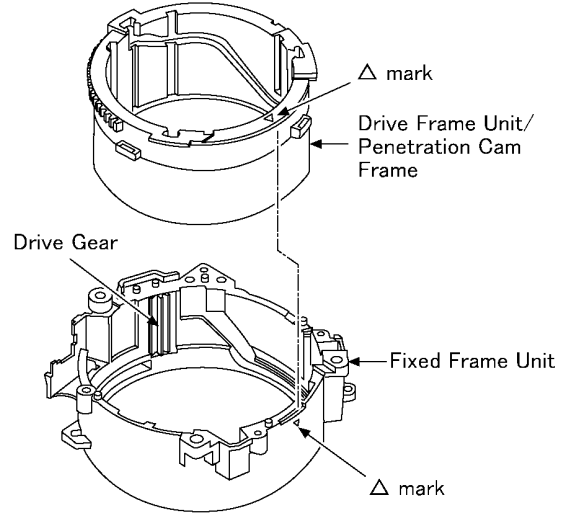

NOTE: (When Installing)

- With aligning the phase of the drive frame unit/ penetration cam frame and the fixed frame unit, confirm the gear of drive frame unit is engaged with the gear of fixed frame unit firmly.

8.5.3. Phase alignment of the 2nd Lens Frame Unit and Both Sides Cam Frame

- Align the Δ mark of 2nd lens frame unit and the Δ mark of both sides cam frame, and then install the 2nd lens frame unit to both sides cam frame.

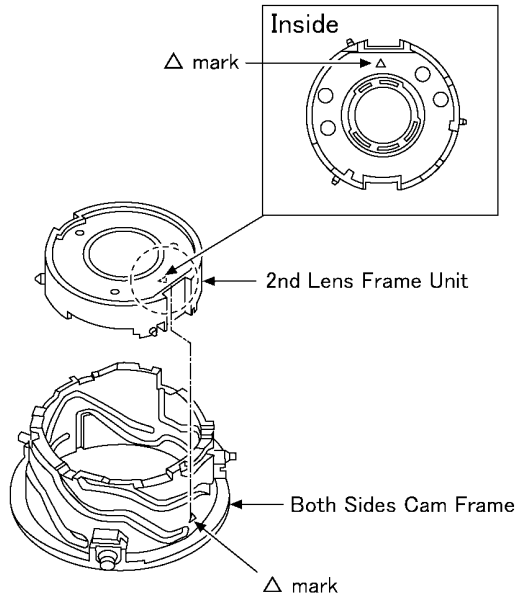

NOTE: (When Installing)

- Take care not to put fingerprint of the lens.

8.5.5. Phase alignment of the 3rd Lens Frame Unit and 2nd Lens Frame Unit/Both Sides Cam Frame/2nd 3rd Direct Frame

- Align the flex guide part on left side of Δ mark of 2nd 3rd direct frame and the shutter flex part of 3rd lens frame unit, and then install the 3rd lens frame unit to 2nd 3rd direct frame.

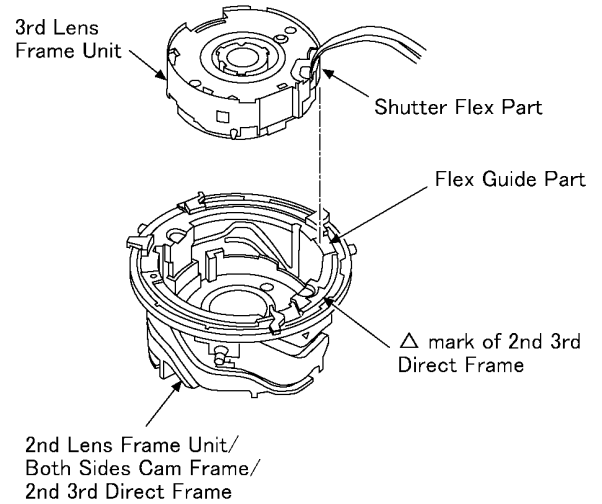

NOTE: (When Installing)

- Take care not to put fingerprint of the lens.
- Take care not to damage the flex.

8.5.4. Phase alignment of the 2nd 3rd Direct Frame and 2nd Lens Frame Unit/Both Sides Cam Frame

- Align the Δ mark of 2nd 3rd direct frame and the Δ mark of 2nd lens frame unit/both sides cam frame, and then install the 2nd 3rd direct frame to 2nd lens frame unit/both sides cam frame.

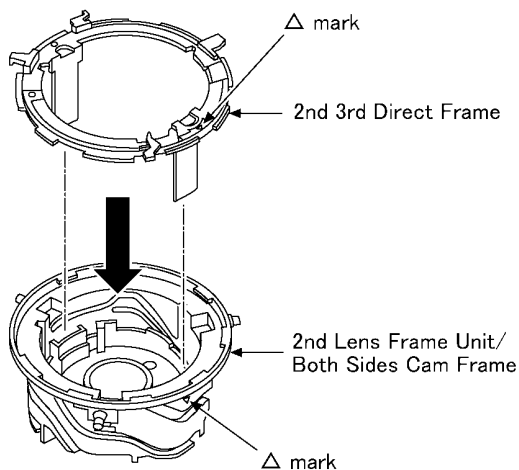

NOTE: (When Installing)

- Take care not to put fingerprint of the lens.

8.5.6. Phase alignment of the 2nd Lens Frame Unit/Both Sides Cam Frame/2nd 3rd Direct Frame/3rd Lens Frame Unit and 1st Lens Frame Unit

1. Align the Δ mark of 2nd lens frame unit/both sides cam frame/2nd 3rd direct frame/3rd lens frame unit and the marking (lengthwise groove) of 1st lens frame unit, and then install the 2nd lens frame unit/both sides cam frame/2nd 3rd direct frame/3rd lens frame unit to 1st lens frame unit.

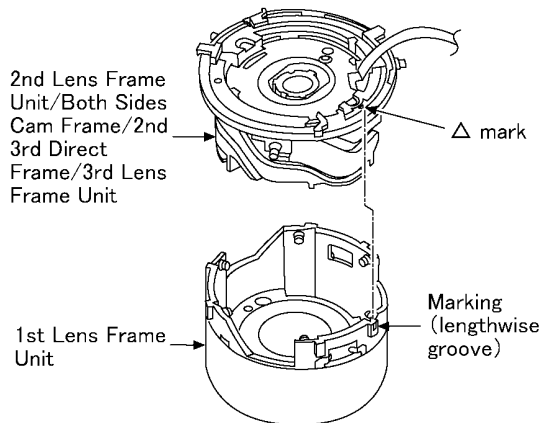

2. Install the 2nd lens frame unit/both sides cam frame/2nd 3rd direct frame/3rd lens frame unit to 1st lens frame unit and then turn in the direction of the arrow fully.

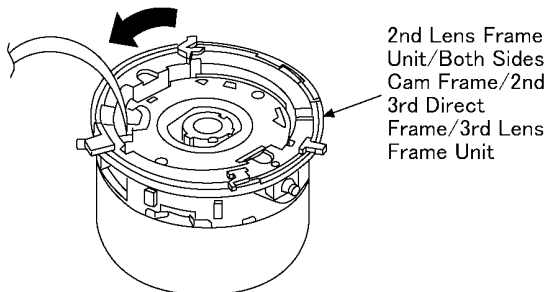

NOTE: (When Installing)

- Take care not to put fingerprint of the lens.
- Take care not to damage the flex.

8.5.7. Phase alignment of the 1st Lens Frame Unit/2nd Lens Frame Unit/Both Sides Cam Frame/2nd 3rd Direct Frame/3rd Lens Frame Unit and 1st Direct Frame Unit

- Align the Δ mark of 1st lens frame unit/2nd lens frame unit/both sides cam frame/2nd 3rd direct frame/3rd lens frame unit and the concave part of 1st direct frame unit, and then install the 1st lens frame unit/2nd lens frame unit/both sides cam frame/2nd 3rd direct frame/3rd lens frame unit to 1st direct frame unit.

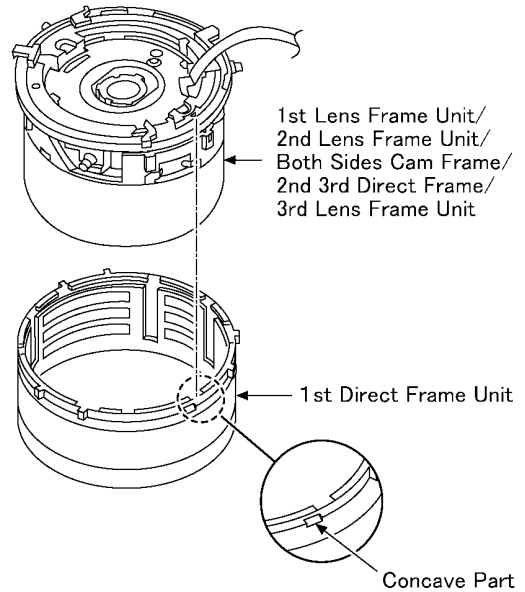

NOTE: (When Installing)

- Take care not to put fingerprint of the lens.
- Take care not to damage the flex.

8.5.8. Phase alignment of the 1st Direct Frame Unit/1st Lens Frame Unit/2nd Lens Frame Unit/Both Sides Cam Frame/2nd 3rd Direct Frame/3rd Lens Frame Unit and Fixed Frame Unit/Drive Frame Unit/Penetration Cam Frame

- Align the Δ mark of 1st direct frame unit/1st lens frame unit/2nd lens frame unit/both sides cam frame/2nd 3rd direct frame/3rd lens frame unit and the Δ mark of fixed frame unit/drive frame unit/penetration cam frame, and then install the 1st direct frame unit/1st lens frame unit/2nd lens frame unit/both sides cam frame/2nd 3rd direct frame/3rd lens frame unit to fixed frame unit/drive frame unit/penetration cam frame.

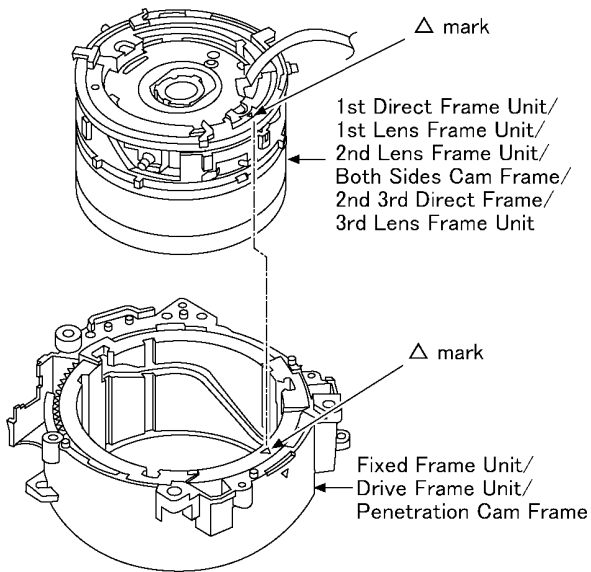

NOTE: (When Installing)

- Take care not to put fingerprint of the lens.
- Take care not to damage the flex.

FRONT VIEW

- Install the 1st lens frame unit so that the "LEICA" character may become the position of the figure below.

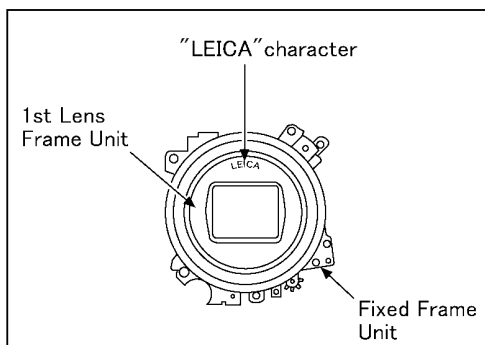

8.5.9. Install of the Master Flange Unit

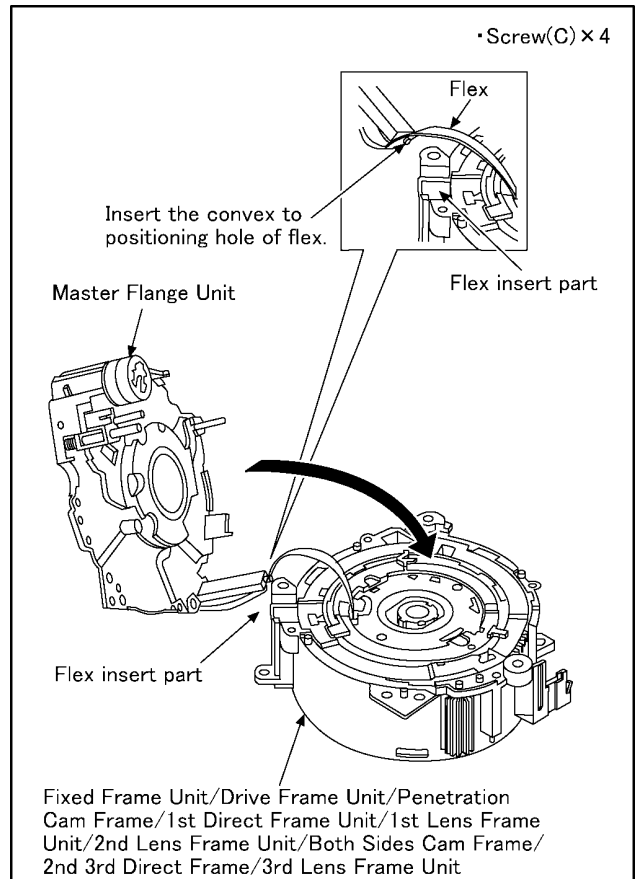

NOTE: (When Installing)

- Take care not to damage the flex.
- Refer to "THE APPLICATION OF GREASE METHOD" when installing the master flange unit.

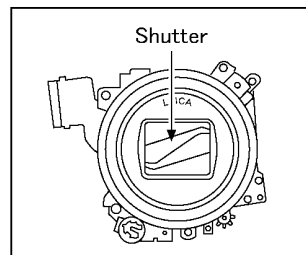

- Turn the Drive Gear in the direction of arrow, and then confirm the lens shutter is closed.

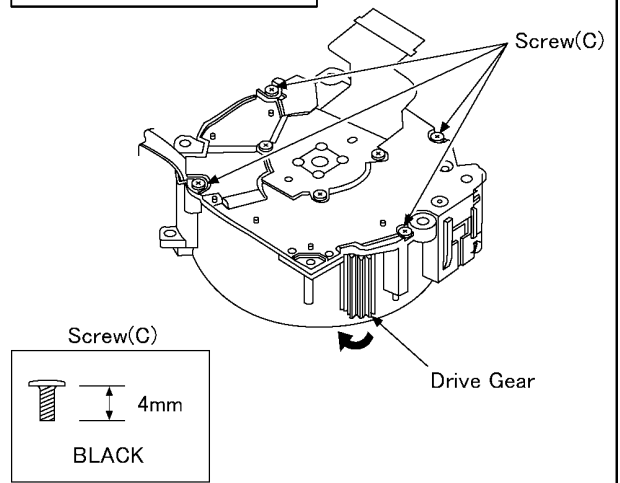

8.5.10. Install of the Lens FPC Unit and Zoom Motor

8.6. Removal of the CCD Unit

To prevent the CCD unit from catching the dust and dirt, do not remove the CCD unit except for replacing.

- Lock × 5
- Solder(C) (16 points)
- Photo Sensor
- Screw(B) × 1
- Solder(B) (4 points)
- Screw(A) × 2
- Lock × 1
- Solder(A) (7 points)

NOTE: (When Installing)

- Align the convex of fixed frame unit and hole of zoom motor, and then install them.

Screw(B)	Screw(A)
SILVER	BLACK

- Screw(D) × 3

Screw(D)	3mm
BLACK	

8.7. Removal of the Focus Motor

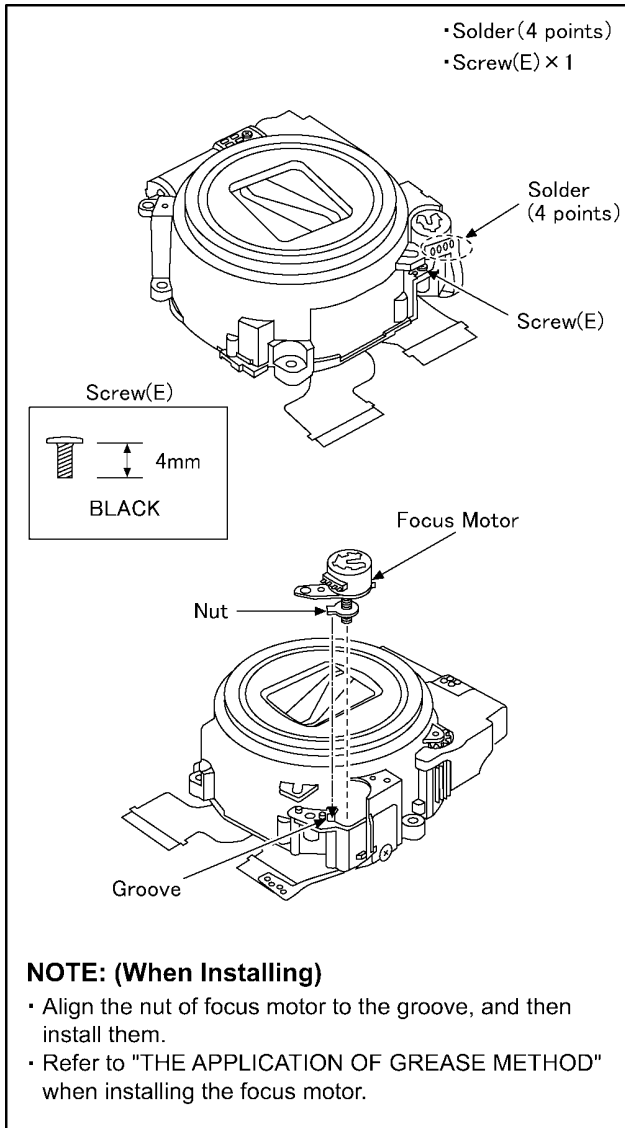

8.8. The Application of Grease Method

The grease application parts of lens unit are as follows.
Apply grease additionally in the specified position if necessary.
When the grease is applied, use a toothpick and apply thinly.

- Focus motor (lead screw)/Fasten groove of nut/Guide pole
 - Grease: RFKZ0472
 - Amount of application: 2 - 4 mg
- Positioning pole
 - Grease: RFKZ0472
 - Amount of application: 1 - 2 mg

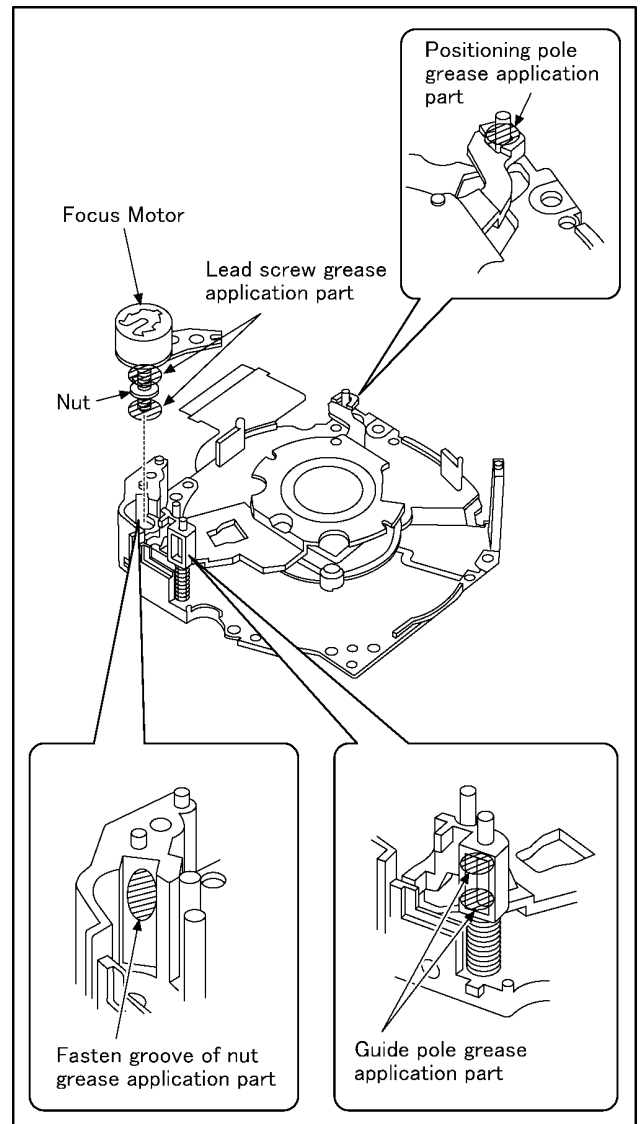

9 Measurements and Adjustments

9.1. Introduction

When servicing this unit, make sure to perform the adjustments necessary based on the part(s) replaced. Before disassembling the unit, it is recommended to back up the camera data stored in flash-rom as a data file.

IMPORTANT NOTICE (After replacing the MAIN P.C.B.)

After replacing the MAIN P.C.B., it is necessary to use the "DIAS" software to allow the release of adjustment flag(s). The Adjustment software "DIAS" is available at "TSN Website". To download, click on "Support Information from NWBG/VDBG-AVC".

*DIAS (DSC Integrated Assist Software)

9.2. Before Disassembling the unit

9.2.1. Initial Setting Release

The cameras specification are initially set in accordance with model suffix (such as EB, EG, GK, GC, and so on.). Unless the initial setting is not released, an automatic alignment software in the camera is not able to be executed when the alignment is carried out.

Note:

The initial setting should be again done after completing the alignment. Otherwise, the camera may not work properly. Therefore as a warning, the camera display a warning symbol "!" on the LCD monitor every time the camera is turned off. Refer to the procedure described in "3.4.2 INITIAL SETTINGS" for details.

[How to Release the camera initial setting]

Preparation:

1. Attach the Battery or AC Adaptor with a DC coupler to the unit.
(Since this unit has built-in memory, it can be performed without inserting SD memory card.)
2. Set the recording mode to the [NORMAL PICTURE] mode.
(Rotate the Mode dial to adjust to the [NORMAL PICTURE] mode. (Camera mark))

Step 1. Temporary cancellation of "INITIAL SETTINGS":

Set the [REC]/[PLAYBACK] selector switch to "[REC] (Camera mark)".

While keep pressing "[UP] of Cursor button" and [DISPLAY] button simultaneously, turn the Power on.

Step 2. Cancellation of "INITIAL SETTINGS":

Set the [REC]/[PLAYBACK] selector switch to "[PLAYBACK]".

Press "[UP] of Cursor button" and [DISPLAY] button simultaneously. (The camera will beep after this.)

Turn the Power off. (The warning symbol "!" is displayed on the LCD monitor.)

9.2.2. Flash-Rom Data Backup

When trouble occurs, it is recommended to backup the Flash-rom data before disassembling the unit.

There are two kinds of Flash-rom data backup methods:

[ROM_BACKUP (Method of Non-PC backup)]

1. Insert the SD-card into the camera.
2. Set the camera to "Temporary cancellation of the initial settings".
3. Select the "SETUP" menu.
From the "SETUP" menu, select "ROM BACKUP".

NOTE:

This item is not listed on the customer's "SETUP" menu.

4. When this "ROM_BACKUP" item is selected, the following submenus are displayed.

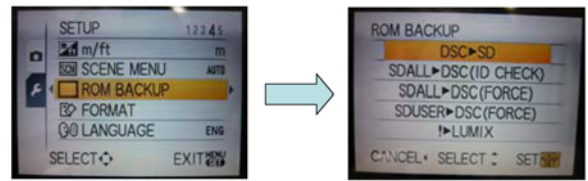

Item	Function	Details
DSC → SD	Save all the DSC's Flash-rom data to SD-CARD	*DSC's Flash-rom data is saved to the SD-CARD as a data file by the same format as the TATSUJIN software for the previous models. (DATA BACKUP) -File location: ROOT DIRECTORY in SD-CARD. -File Name: 1) User Setup Information data: <Model Number>U.txt [Example: DMC-FX66 : "FX66U.txt"] 2) Optical Adjustment data: <Model Number>F.txt [Example: DMC-FX66 : "FX66F.txt"] *If the concerned file already exists, "OVERWRITE?" message is displayed.
SDALL → DSC (ID CHECK)	Write the all data to DSC's Flash-rom from SD-CARD	*The backup data being stored in the SD card is transferred to DSC unit. *ID CHECK: When the model ID is different, data is not transferred.
SDALL → DSC (FORCE)	Write the all data to DSC's Flash-rom from SD-CARD	*FORCE: Even if the model ID is different, data is transferred. ※If the main PCB is replaced, select "SDALL → DSC (FORCE)".
SDUSER → DSC (FORCE)	Only "User setup information" is written from the saved file in the SD-CARD to DSC's Flash-rom.	*Only the user's "setup" setting condition is transferred to DSC unit. *FORCE: Even if the model ID is different, the data is transferred.
! → LUMIX	Shipping set without initializing "User setup information"	*Initial setting is executed without initializing the user's set up setting condition. ※ The initial setting must be perform while the Self-timer LED is blinking. ※ The picture data stored in the built-in memory of the DSC is not erased, with this operation.

[DSC Integrated Assist Software (Method of Using PC)]

Same as TATSUJIN software for previous models.

9.2.3. Light Box

If using VFK1164TDVLB Light Box, remove the lens connection ring by loosening three hexagon screws.

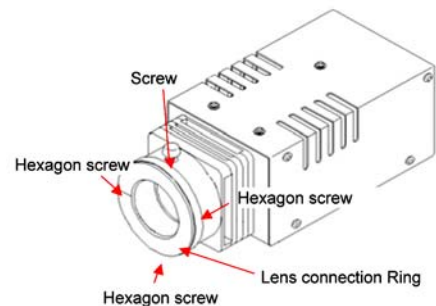

9.3. Details of Electrical Adjustment

9.3.1. How to execute the Electrical Adjustment

It is not necessary to connect the camera to a PC to perform adjustments.

“Flag reset operation” and “Initial setting operation” are required when carrying out the alignment, follow the procedure below.

9.3.1.1. Startup Electrical Adjustment mode

1. Release the initial settings.
2. Insert a recordable SD card.
(Without a SD card, the automatic adjustment can not executed.)
3. Procedure to set the camera into adjustment mode:
 - a. Set the mode into [NORMAL PICTURE] mode.
 - b. Turn the Power off.
 - c. Turn the Power on pressing [DISPLAY] and [MENU/SET] simultaneously.
LCD monitor displays “SERVICE MODE”.(Refer to Fig. 3-1)



Fig. 3-1

9.3.1.2. Status Adjustment Flag Setting

Reset (Not yet adjusted) the status flag condition.

1. After pressing the [DISPLAY] button, the LCD monitor displays the Flag status screen (Refer to Fig.3-2)
2. Select item by pressing the Cursor buttons. (Gray cursor is moved accordingly.)
3. Press the [Delete] button.

NOTE:

The selected item's flag has been changed from “F (green)” to “0 (yellow)”.

*(Refer to Fig. 3-3)

*Flag conditions:

F (green)

means that the alignment has been completed and the status flag condition is set. In this case, the flag condition should be reset, if you try to carry out the automatic alignment.

0 (yellow)

means that the alignment has been not “completed” and the status flag condition is “reset”. In this case, automatic alignment is available.

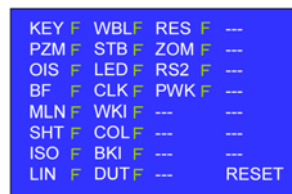

Fig. 3-2

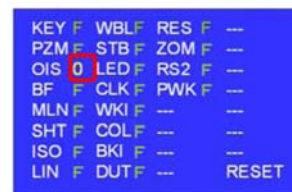

Fig. 3-3

<Example: OIS flag is reset. >

- In case of setting the status flag into set condition again without completion of the alignment, the status flag should be SET by using PC, or UNDO by using ROM BACKUP function.

9.3.1.3. Execute Adjustment (In case of “OIS Adjustment”)

1. Perform step “9.3.1.1.” to “9.3.1.2.”, to reset the OIS flag status “F” (Set) to “0” (Reset)
2. Press [DISPLAY] button after Flag reset.
OIS Adjustment screen is displayed on the LCD panel.
(Refer to Fig.3-4)
3. Press the [Shutter] button. The adjustment will start automatically.



Fig. 3-4

4. When the adjustment is completed successfully, adjustment report menu appears with Green OK on the LCD monitor. (Refer to Fig.3-5)



Fig. 3-5

9.3.1.4. Attention point during Adjustment

1. Step “9.3.1.3.” procedure shows OIS adjustment as an example. To perform the adjustment, refer to the “9.3.2. Adjustment Specifications” table which shows key point for each adjustment.
2. Do not move the light box, the camera or the chart while adjusting. If one of these is moved accidentally, start the adjustment again.
3. Do not press any buttons/keys until the default menu (Fig.3-6) is displayed on the LCD monitor. Otherwise, adjustment data may not be stored properly.
4. If the adjustment is interrupted accidentally, the alignment data may not be properly saved in the Flash-rom.



Fig. 3-6

9.3.1.5. Finalizing the Adjustment

1. Several adjustment flags can be reset (“F” into “0”) at the same time. In this case, when the adjustment has been completed, the screen will change showing the adjustment for the next item until all reset items are completed.
Also, when the shutter button is pressed, the screen jump to the next adjustment item.
2. To cancel the adjustment mode while in the process of performing the adjustment, follow this procedures.
 - (1) Press [Delete] button.
 - (2) Press [RIGHT] of Cursor button.

NOTE:

- If adjustment is cancelled with above procedure, adjustment is not completed. Make sure to adjust it later.
- Adjustment software “DIAS” is able to control the status of the adjustment flags.

9.3.2. Adjustment Specifications

The following matrix table shows the relation between the replaced part and the Necessary Adjustment. When a part is replaced, make sure to perform the necessary adjustment(s) in the order indicated. The table below shows all the information necessary to perform each adjustment.

Adjustment order	Adjustment Item	FLAG	Purpose	Replacing Parts						JIG/TOOLS	SET UP	How to Operate
				MAIN PCB	VENUS (IC6001)	MCPI (IC6002)	Lens Parts (except for CCD)		CCD Unit			
1	Venus Zoom	PZM	Venus Zoom Inspection	○	○	○	—	—	—	NONE	NONE	1) Press Shutter Button 2) After displaying "PZM", press Shutter Button again. 3) After completed, the "OK" menu appears.
2	OIS sensor	OIS	OIS sensor output level adjustment	○	○	○	—	—	—	NONE	NONE	1) Press Shutter Button (Do not apply any shock and vibration for the camera while adjusting) 2) After completed, the "OK" menu appears.
3	Backfocus / GYRO	BF	To have the focus tracking curve be appropriate shape and GYRO sensor adjustment	○	○	○	○	※1	○	+COLLIMATOR (VFK1164TCM02 or VFK1164TCM03 or RFKZ0422)	1) Set the camera in front of collimator so that the distance from collimator to camera becomes about 4 cm as shown in Fig.A. 【NOTE】 Please notice ! "NG" might happen while auto adjusting. - Do not put the black colored stuff at the back side of collimator near hunching chart to get some certain brightness. - Make sure the hunching chart has no dust and dirty condition. - Not connect the USB cable at this stage.	1) Press Shutter Button (Do not apply any shock and vibration for the camera while adjusting) 2) After completed, the "OK" menu appears.
4	Monitor Linearity	MLN	Monitor Linearity adjustment	○	○	○	○	○	—	+LIGHT BOX (VFK1164TDVLB or RFKZ0523)	1) Set the camera in front of LIGHTBOX so that the distance from collimator to camera becomes about 16 cm as shown in Fig.B.	1) Press Shutter Button 2) After completed, the "OK" menu appears.
5	Shutter	SHT	Shutter speed adjustment	○	○	○	○	○	—	+LIGHT BOX (VFK1164TDVLB or RFKZ0523) +TR CHART (RFKZ0443)	1) Insert the TR chart into the slot of LIGHTBOX. 2) Set the camera in front of LIGHTBOX so that the distance from LIGHTBOX to camera becomes about 16 cm as shown in Fig.B. 3) Set the camera angle so that the color chart is displayed on the LCD monitor fully. 【NOTE】 - Since the lens position is automatically set into certain position after executing auto adjustment, confirm the angle after stopping the lens zoom position. - It is no problem even though the chart on to the LCD monitor slightly cut at the corner. - It is no problem even though the focusing slightly becomes out of focusing condition. - Not connect the USB cable at this stage.	1) Press Shutter Button 2) After completed, the "OK" menu appears.
6	ISO	ISO	ISO sensitivity adjustment	○	○	○	○	○	—		1) Press Shutter Button 2) After completed, the "OK" menu appears.	
7	White Balance	WBL	White balance adjustment under various color temperature	○	○	○	○	○	—		1) Press Shutter Button 2) After completed, the "OK" menu appears.	
8	High brightness coloration	LIN	High brightness coloration adjustment	○	○	○	○	○	—		1) Press Shutter Button 2) After completed, the "OK" menu appears.	
9	CCD Missing Pixels (White)	WKI	Compensation of CCD Missing Pixels (White)	○	○	○	—	※1	—	NONE	NONE	1) Press Shutter Button 2) After completed, the "OK" menu appears.
10	Color reproduction inspection and Microphone check	COL	Color reproduction inspection and Microphone check	○	○	○	○	○	—	NONE	NONE	1) Press Shutter Button 2) After completed, the "OK" menu appears.
11	CCD Missing Pixels (Black)	BKI	Compensation of CCD Missing Pixels (Black)	○	○	○	—	※1	—	+LIGHT BOX (VFK1164TDVLB or RFKZ0523)	1) Set the camera in front of LIGHTBOX so that the distance from collimator to camera becomes about 16 cm as shown in Fig.B.	1) Press Shutter Button 2) After completed, the "OK" menu appears.

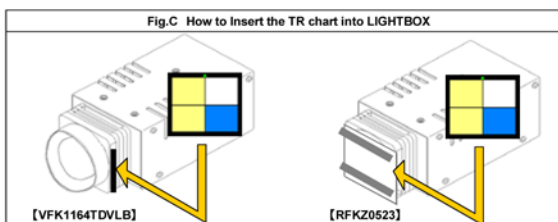
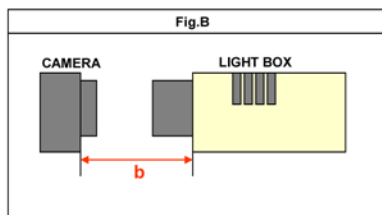
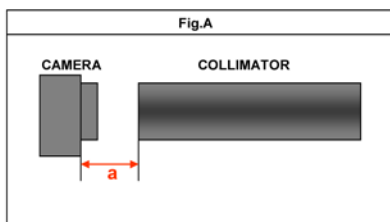

IMPORTANT NOTICE (After replacing the MAIN P.C.B.)

After replacing the MAIN P.C.B., make sure to perform the "INITIAL SETTINGS" first, then release the "INITIAL SETTINGS" in order to proceed the electrical adjustment.

NOTE:

- 1) If electrical adjustment or data re-writing is executed before "INITIAL SETTINGS", suffix code list is never displayed, and it cannot be chosen suitable suffix code.
- 2) Never remove the battery during initial setting in process.

9.4. After Adjustment

9.4.1. Initial Setting

Since the initial setting has been released to execute the built-in adjustment software, it should be set up again before shipping the camera to the customer.

Refer to the procedure described in “3.4.2. INITIAL SETTINGS” for details.

[IMPORTANT]

1. The initial setting should be done again after completing the alignment. Otherwise, the camera will not work properly.
Therefore as a warning, the camera display a warning symbol “ ! ” on the LCD monitor every time the camera is turned off.
2. Confirm that status of all adjustment flag show “F”. Even if one of the adjustment flag shows “0”, initial setting programmed is never executed.
3. Adjustment software “DIAS” is able to control the status of the adjustment flags.
The Adjustment software “DIAS” is available at “TSN Website”, therefore, access to “TSN Website” at “Support Information from NWBG/VDBG-AVC”.

10 Maintenance

10.1. Cleaning Lens and LCD Panel

Do not touch the surface of lens and LCD Panel with your hand.

When cleaning the lens, use air-Blower to blow off the dust.

When cleaning the LCD Panel, dampen the lens cleaning paper with lens cleaner, and the gently wipe the its surface.

Note:

The Lens Cleaning KIT ; VFK1900BK (Only supplied as 10 set/Box) is available as Service Aid.

Service Manual

Diagrams and Replacement Parts List

Digital Camera

Model No.

DMC-ZX3EB	DMC-ZR3P	DMC-ZR3GH
DMC-ZX3EE	DMC-ZR3PC	DMC-ZR3GK
DMC-ZX3EF	DMC-ZR3PR	DMC-ZR3GN
DMC-ZX3EG	DMC-ZR3PU	DMC-ZR3GT
DMC-ZX3EP	DMC-ZR3GC	
DMC-ZX3SG	DMC-ZR3GD	

Vol. 1
Colour

[DMC-ZX3]	[DMC-ZR3]
(S).....Silver Type (except EF)	(S).....Silver Type (except PC/PR/GT/GD)
(K).....Black Type (except SG)	(K).....Black Type
(N).....Gold Type (only SG)	(N).....Gold Type (only GC/GH/GT)
(R).....Red Type (except EE)	(R).....Red Type (except PC/PR/GD)
(T).....Brown Type (except EB/EE)	(T).....Brown Type (only GD/GH/GN)
(A).....Blue Type (except EF/SG)	(A).....Blue Type (only P/PC/PU/GN)

Table of contents

S1. About Indication of The Schematic Diagram.....	S-1	S6. Replacement Parts List.....	S-11
S1.1. Important Safety Notice.....	S-1		
S2. Voltage Chart.....	S-2	S7. Exploded View.....	S-16
S2.1. Flash Top P.C.B.....	S-2	S7.1. Frame and Casing Section.....	S-16
S3. Block Diagram.....	S-3	S7.2. Packing Parts and Accessories Section (1).....	S-17
S3.1. Overall Block Diagram.....	S-3	S7.3. Packing Parts and Accessories Section (2).....	S-18
S4. Schematic Diagram.....	S-4		
S4.1. Interconnection Diagram.....	S-4		
S4.2. Flash Top Schematic Diagram.....	S-5		
S4.3. CCD Flex Schematic Diagram.....	S-6		
S4.4. Lens Flex Schematic Diagram.....	S-7		
S5. Print Circuit Board.....	S-8		
S5.1. Flash Top P.C.B.....	S-8		
S5.2. CCD Flex P.C.B.....	S-9		
S5.3. Lens Flex P.C.B.....	S-10		

S1. About Indication of The Schematic Diagram

S1.1. Important Safety Notice

COMPONENTS IDENTIFIED WITH THE MARK \triangle HAVE THE SPECIAL CHARACTERISTICS FOR SAFETY. WHEN REPLACING ANY OF THESE COMPONENTS USE ONLY THE SAME TYPE.

1. Although reference number of the parts is indicated on the P.C.B. drawing and/or schematic diagrams, it is NOT mounted on the P.C.B. when it is displayed with "\$" mark.
2. It is only the "Test Round" and no terminal (Pin) is available on the P.C.B. when the TP (Test Point) indicated as "●" mark.
3. The voltage being indicated on the schematic diagram is measured in "Standard-Playback" mode when there is no specify mode is mentioned.
4. Although the voltage and waveform available on here is measured with standard frame, it may be differ from actual measurement due to modification of circuit and so on.
5. The voltage being indicated here may be include observational-error (deviation) due to internal-resistance and/or reactance of equipment. Therefore, handle the value indicated on here as reference.
6. Use the parts number indicated on the Replacement Parts List .
7. Indication on Schematic diagrams:

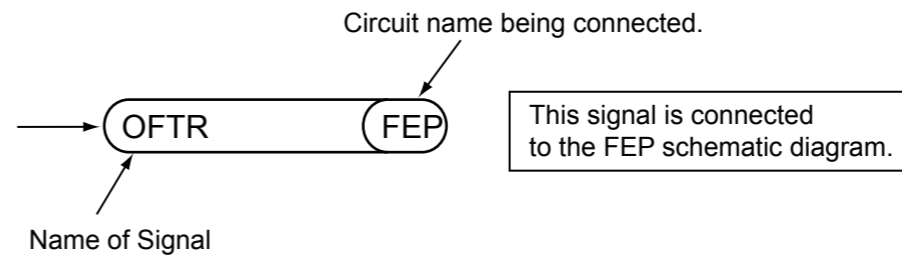

S2. Voltage Chart

Note) Indicated voltage values are the standard values for the unit measured by the DC electronic circuit tester (high-impedance) with the chassis taken as standard.
Therefore, there may exist some errors in the voltage values, depending on the internal impedance of the DC circuit tester.

S2.1. Flash Top P.C.B.

REF No.	PIN No.	POWER ON
IC7301	1	3.1
IC7301	2	0
IC7301	3	0
IC7301	4	0
IC7301	5	1.4
IC7301	6	1.4
IC7301	7	0
IC7301	8	3.1
IC8100	1	0
IC8100	2	0
IC8100	3	0
IC8100	4	0
IC8100	5	3.4
IC8100	6	0
IC8100	7	0
IC8100	8	0
IC8100	9	3.1
IC8100	10	4.0

S3. Block Diagram

S3.1. Overall Block Diagram

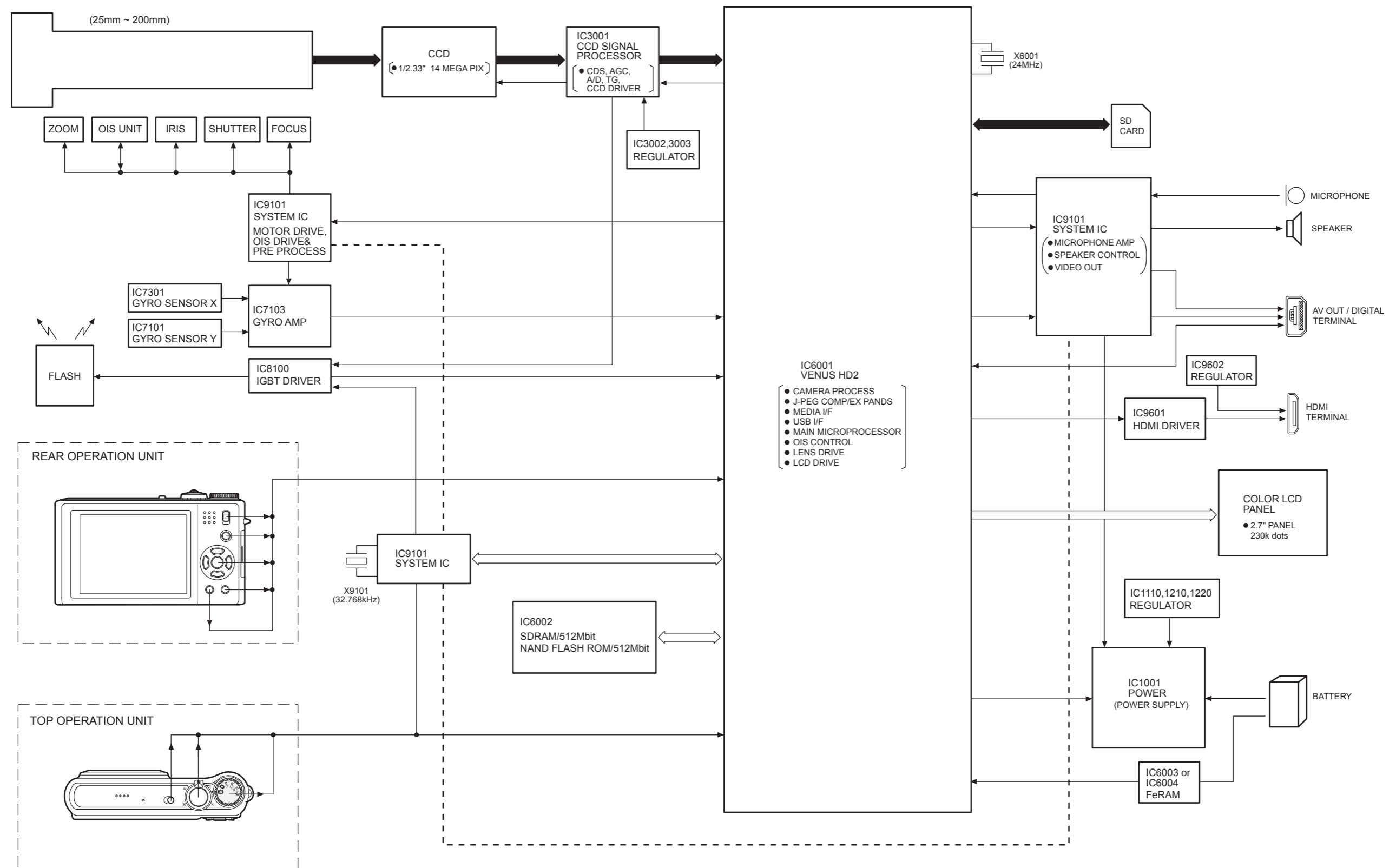

S4. Schematic Diagram

S4.1. Interconnection Diagram

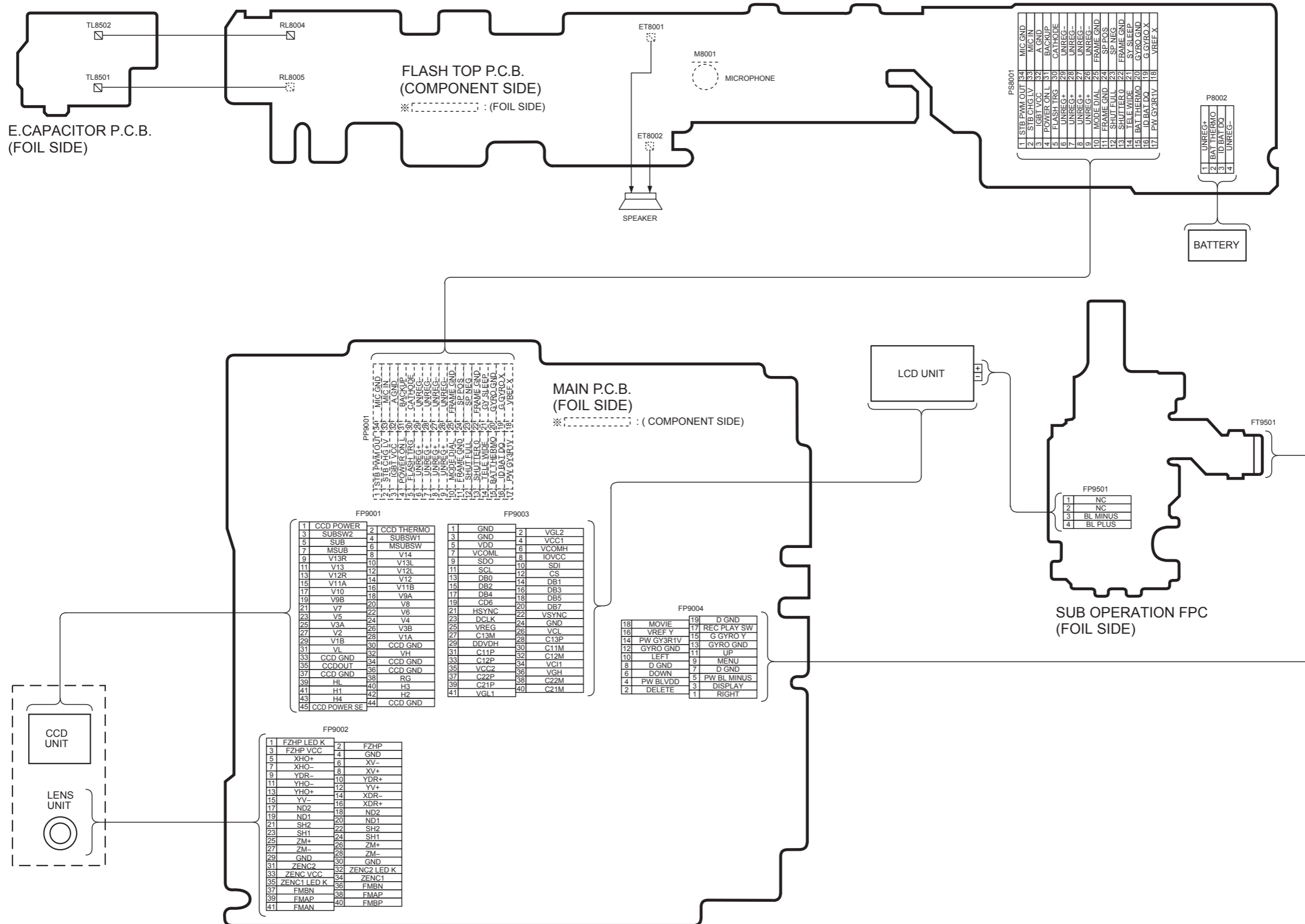

S4.2. Flash Top Schematic Diagram

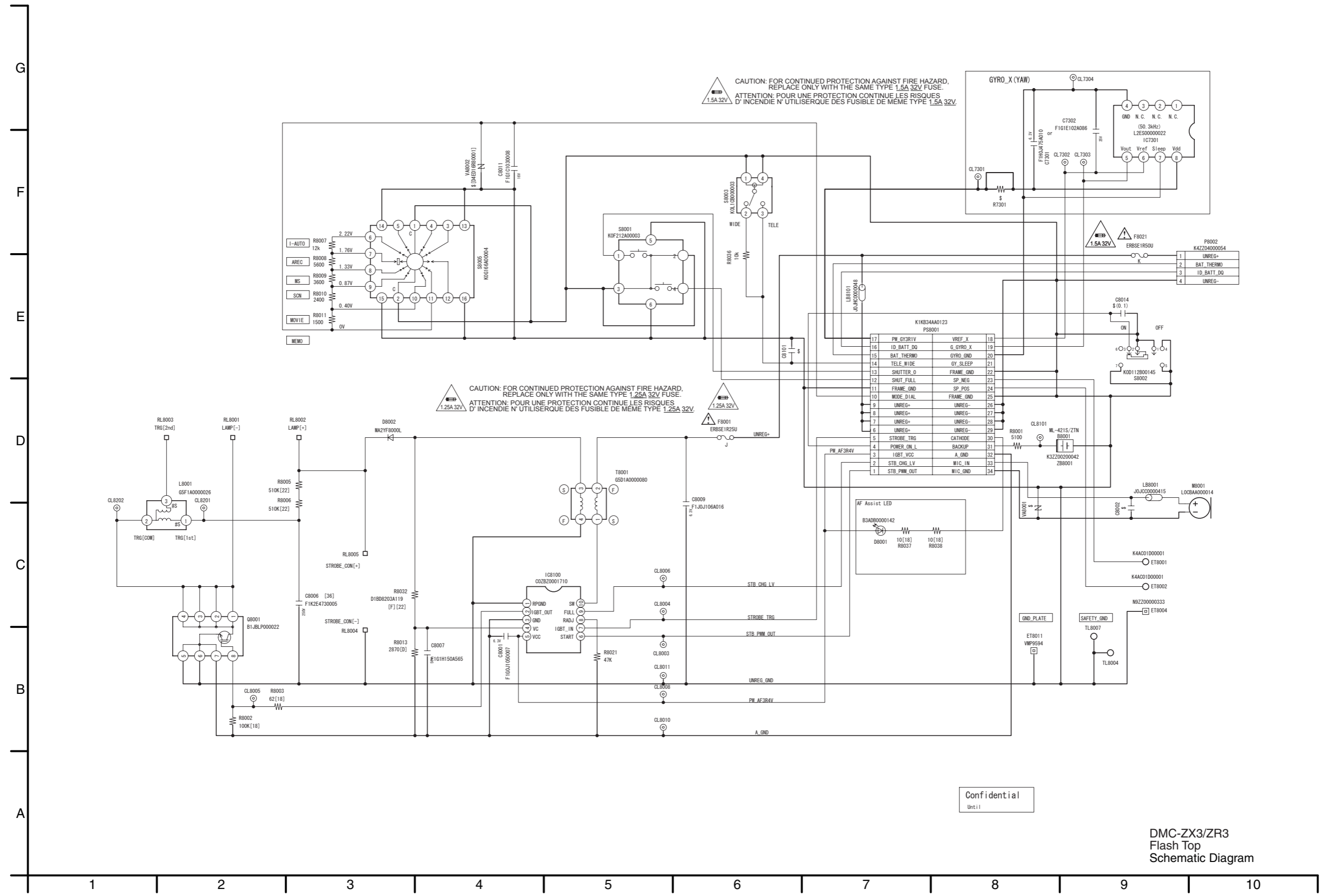

Confidential
 Untill

S4.3. CCD Flex Schematic Diagram

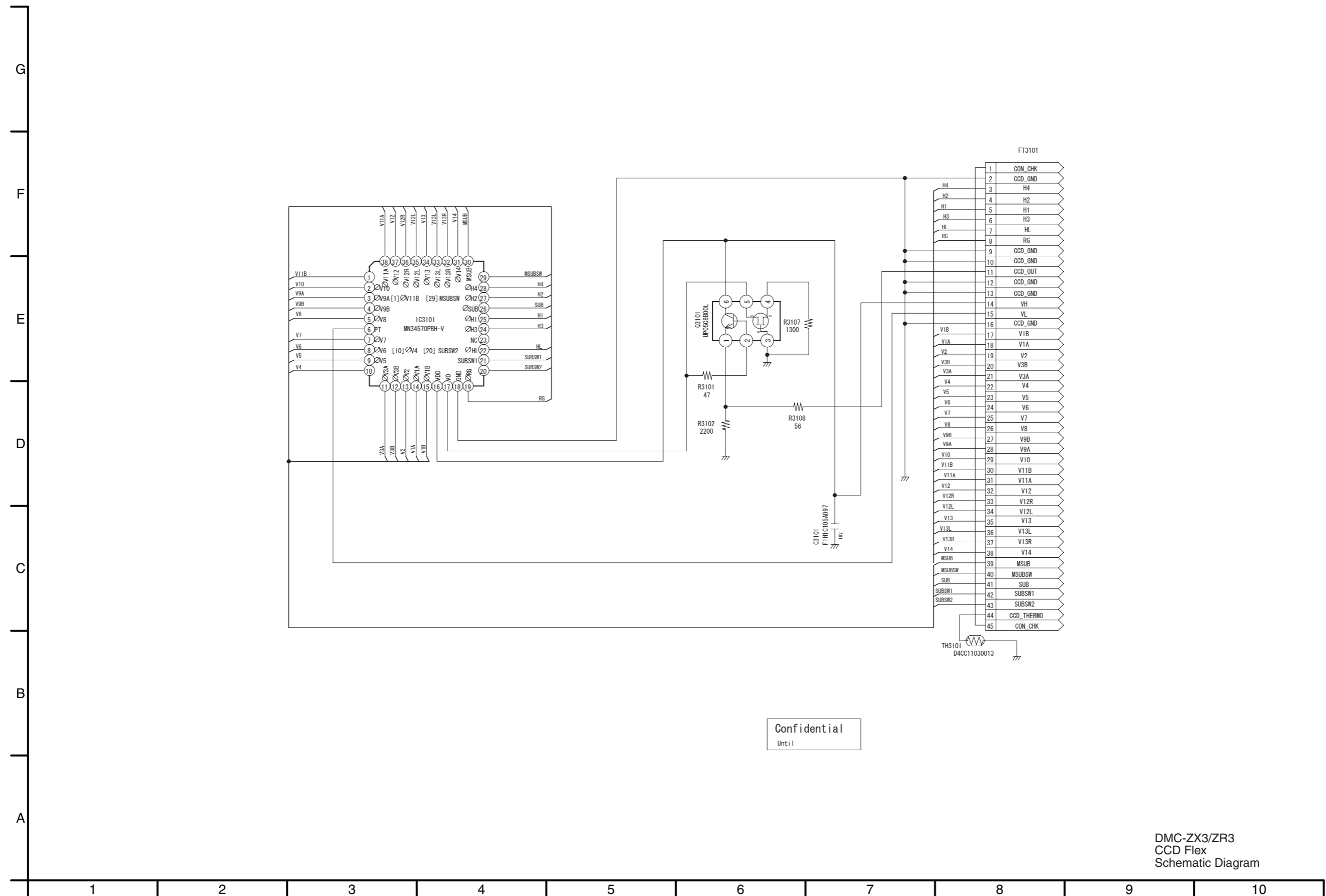

Confidential
Until

S4.4. Lens Flex Schematic Diagram

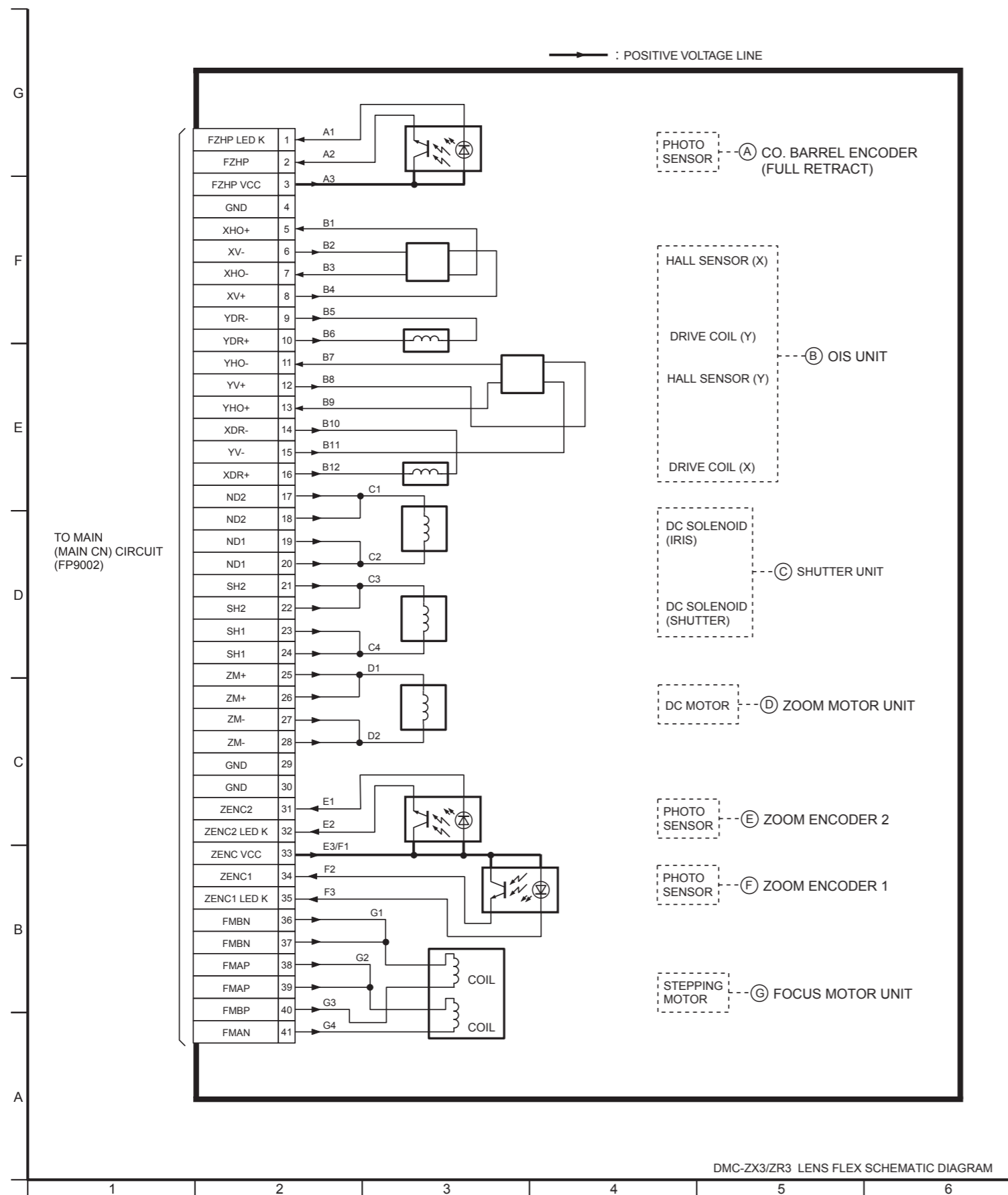

S5. Print Circuit Board

S5.1. Flash Top P.C.B.

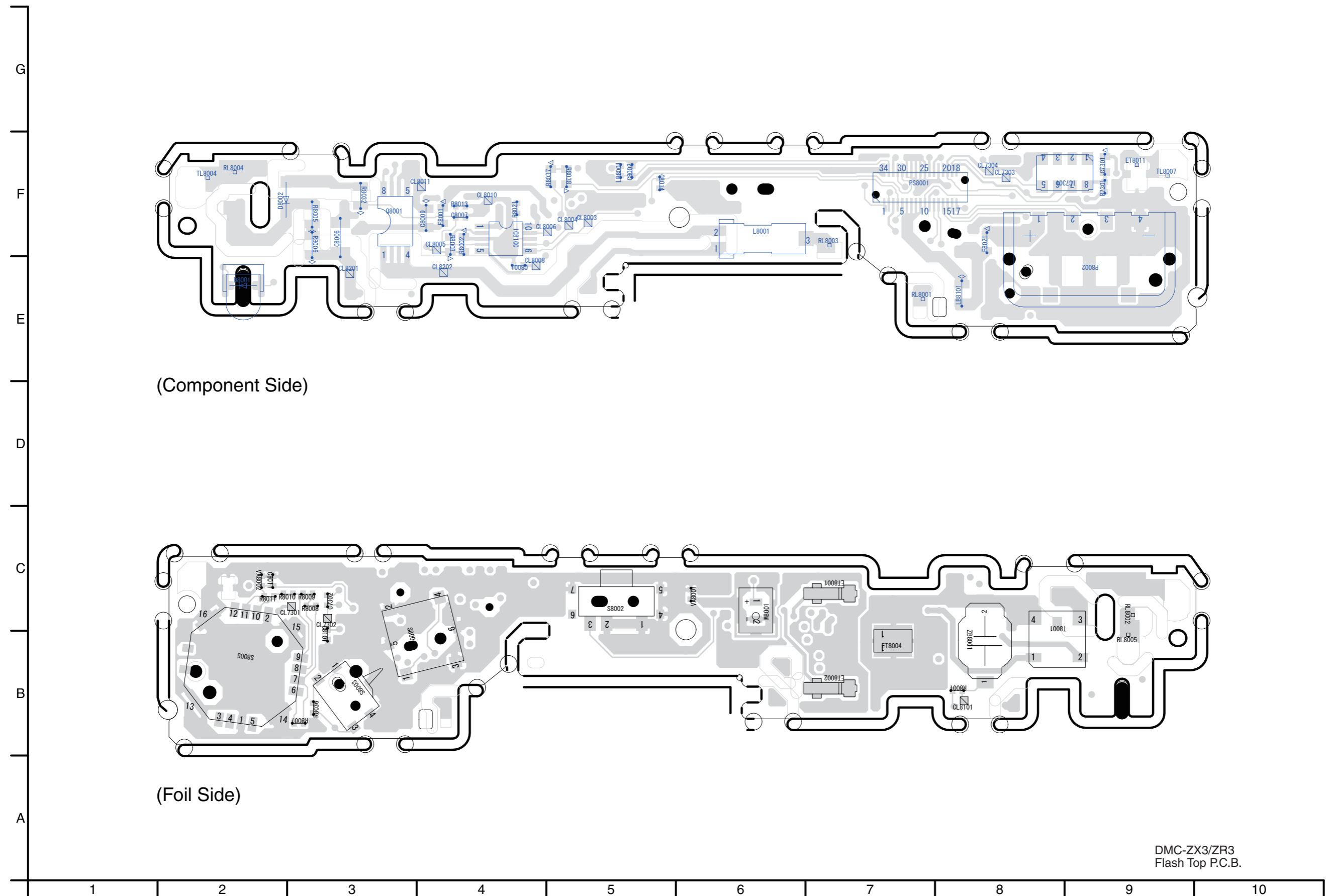

(Component Side)

(Foil Side)

DMC-ZX3/ZR3
Flash Top P.C.B.

S5.2. CCD Flex P.C.B.

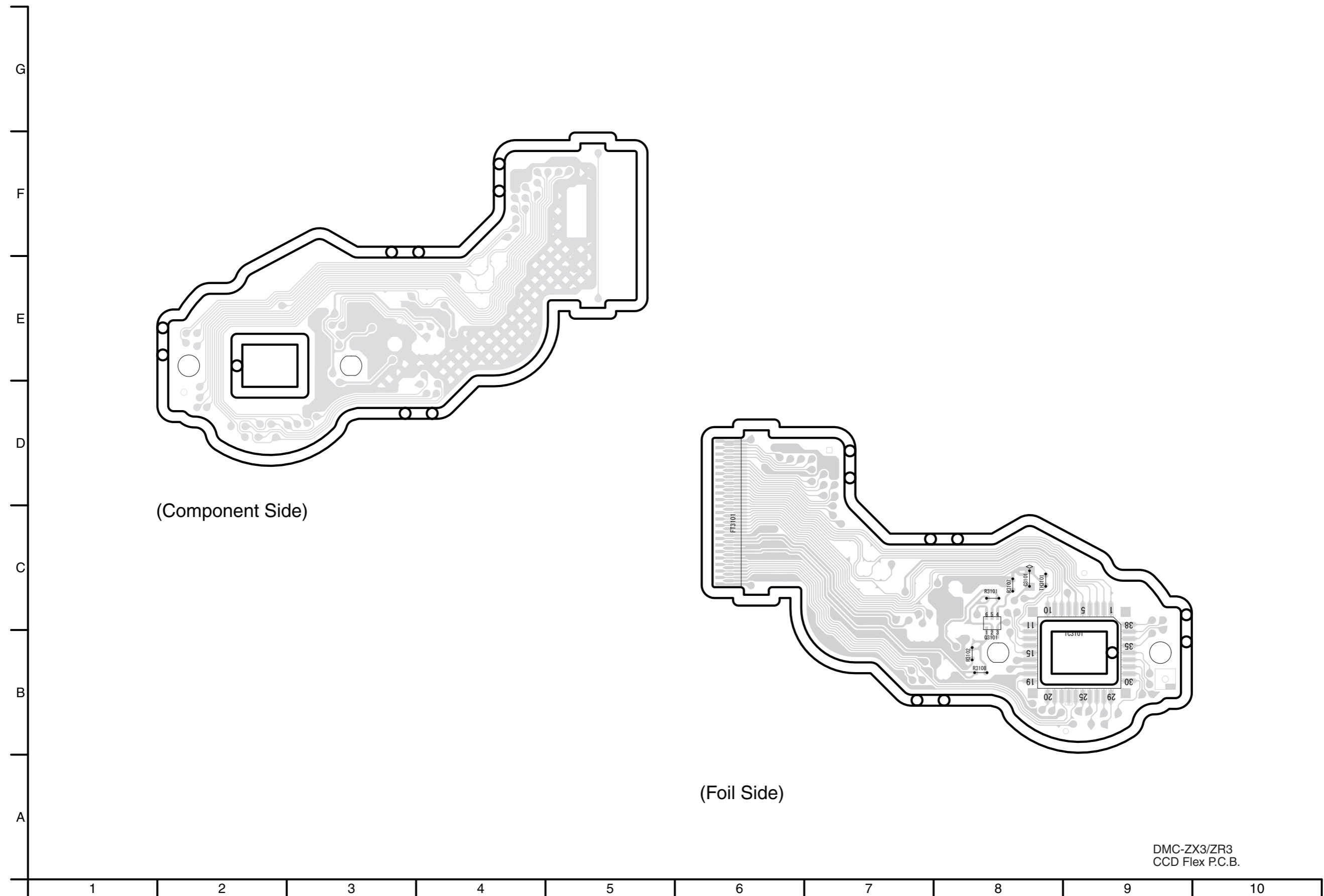

S5.3. Lens Flex P.C.B.

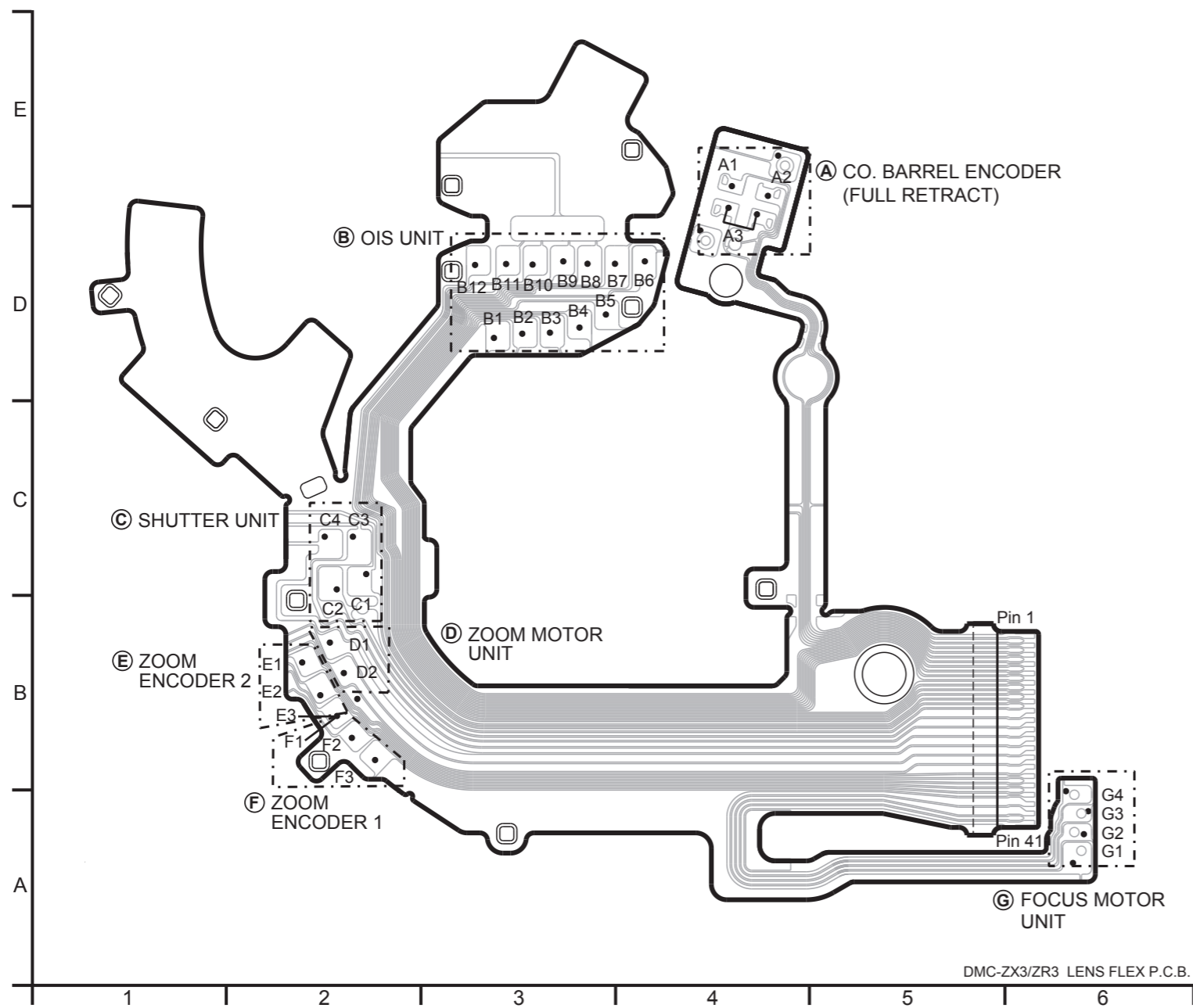

S6. Replacement Parts List

- Note:
1. * Be sure to make your orders of replacement parts according to this list.
 2. IMPORTANT SAFETY NOTICE
Components identified with the mark \triangle have the special characteristics for safety.
When replacing any of these components, use only the same type.
 3. Unless otherwise specified,
All resistors are in OHMS, K=1,000 OHMS. All capacitors are in MICRO-FARADS (uf), P=uuF.
 4. The marking (RTL) indicates the retention time is limited for this item. After the discontinuation of this assembly in production, it will no longer be available.
 5. Supply of CD-ROM, in accordance with license protection, is allowable as replacement parts only for customers who accidentally damaged or lost their own.

E.S.D. standards for Electrostatically Sensitive Devices, refer to PREVENTION OF ELECTROSTATIC DISCHARGE (ESD) TO ELECTROSTATICALLY SENSITIVE (ES) DEVICES section.

Definition of Parts supplier:

1. Parts marked with [ENERGY] in the remarks column are supplied from Panasonic Corporation Energy Company.
2. Parts marked with [PAVCSG] in the remarks column are supplied from PAVCSG.
Others are supplied from AVC-CSC-SPC.

Ref.No.	Part No.	Part Name & Description	Pcs	Remarks
##	VEP56100B	MAIN P.C.B.	1	EG,EP,EF,EB,PR (RTL) E.S.D.
##	VEP56100A	MAIN P.C.B.	1	EE,SG,P,PC,PU,GC,GH,GT, GK,GN,GD (RTL) E.S.D.
##	VEP50058A	SUB OPERATION FPC UNIT	1	(RTL) E.S.D.
##	VEK0Q27	FLASH TOP P.C.B.	1	(RTL) [PAVCSG] E.S.D.
##	VEP58111A	E. CAPACITOR P.C.B.	1	[PAVCSG]
##	VEK0P96	CCD UNIT	1	E.S.D.
##	VEK0Q27	FLASH TOP P.C.B.		(RTL) [PAVCSG] E.S.D.
C7301	F1H0J475A010	C.CAPACITOR CH 6.3V 4.7U	1	[PAVCSG]
C7302	F1G1E102A086	C.CAPACITOR CH 25V 1000P	1	[PAVCSG]
C8001	F1G0J1050007	C.CAPACITOR CH 6.3V 1U	1	[PAVCSG]
C8006	F1K2E4730005	C.CAPACITOR 250V 0.047U	1	[PAVCSG]
C8007	ECJ0EC1H150J	C.CAPACITOR CH 50V 15P	1	[PAVCSG]
C8009	F1J0J106A020	C.CAPACITOR CH 6.3V 10U	1	[PAVCSG]
C8011	F1G1C1030008	C.CAPACITOR CH 16V 0.01U	1	[PAVCSG]
D8001	B3ADB0000142	DIODE	1	[PAVCSG] E.S.D.
D8002	MA2YF8000L	DIODE	1	[PAVCSG] E.S.D.
ET8001	K4AC01D00001	EARTH SPRING	1	[PAVCSG]
ET8002	K4AC01D00001	EARTH SPRING	1	[PAVCSG]
ET8004	N9ZZ00000333	EARTH SPRING	1	[PAVCSG]
△ F8001	ERBSE1R25U	FUSE 32V 1.25A	1	[PAVCSG]
△ F8021	ERBSE1R50U	FUSE 32V 1.5A	1	[PAVCSG]
IC7301	L2ES00000022	IC	1	[PAVCSG] E.S.D.
IC8100	C0ZB20001710	IC	1	[PAVCSG] E.S.D.
L8001	G5F1A0000026	INDUCTOR	1	[PAVCSG]
LB8001	J0JCC0000415	FILTER	1	[PAVCSG]
LB8101	J0JHC0000048	FILTER	1	[PAVCSG]
M8001	L0CBAA000014	MICROPHONE	1	[PAVCSG]
P8002	K4ZZ04000054	CONNECTOR 4P	1	[PAVCSG]
PS8001	K1KB34AA0123	CONNECTOR 34P	1	[PAVCSG]
Q8001	B1JBLP000022	TRANSISTOR	1	[PAVCSG] E.S.D.
R7301	ERJ2GE0R00X	M.RESISTOR CH 1/16W 0	1	[PAVCSG]
R8001	ERJ2GEJ512X	M.RESISTOR CH 1/16W 5.1K	1	[PAVCSG]
R8002	ERJ3GEYJ104V	M.RESISTOR CH 1/10W 100K	1	[PAVCSG]
R8003	ERJ3GEYJ620V	M.RESISTOR CH 1/10W 62	1	[PAVCSG]
R8005	ERJ6GEYJ514V	M.RESISTOR CH 1/10W 514K	1	[PAVCSG]
R8006	ERJ6GEYJ514V	M.RESISTOR CH 1/10W 514K	1	[PAVCSG]
R8007	ERJ2GEJ123X	M.RESISTOR CH 1/16W 12K	1	[PAVCSG]
R8008	ERJ2GEJ562X	M.RESISTOR CH 1/10W 5.6K	1	[PAVCSG]
R8009	ERJ2GEJ362X	M.RESISTOR CH 1/10W 3.6K	1	[PAVCSG]
R8010	ERJ2GEJ242X	M.RESISTOR CH 1/16W 2.4K	1	[PAVCSG]
R8011	ERJ2GEJ152X	M.RESISTOR CH 1/16W 1.5K	1	[PAVCSG]
R8013	ERJ2RHD2871X	M.RESISTOR CH 1/16W 2870	1	[PAVCSG]
R8021	ERJ2GEJ473X	M.RESISTOR CH 1/16W 47K	1	[PAVCSG]
R8032	D1BD8203A119	RESISTOR	1	[PAVCSG]
R8036	ERJ2GEJ103X	M.RESISTOR CH 1/10W 10K	1	[PAVCSG]
R8037	ERJ3GEYJ100V	M.RESISTOR CH 1/10W 10	1	[PAVCSG]
R8038	ERJ3GEYJ100V	M.RESISTOR CH 1/10W 10	1	[PAVCSG]
S8001	K0F212A00003	SWITCH	1	[PAVCSG]
S8002	K0D112B00145	SWITCH	1	[PAVCSG]
S8003	K0L1CB000003	SWITCH	1	[PAVCSG]
S8005	K0G166A00004	SWITCH	1	[PAVCSG]
T8001	G5D1A0000080	TRANSFORMER	1	[PAVCSG]
ZB8001	K3ZZ00200042	BATTERY HOLDER	1	[PAVCSG]

Ref.No.	Part No.	Part Name & Description	Pcs	Remarks
##	VEK0P96	CCD UNIT		E.S.D.
C3101	F1H1C105A097	C.CAPACITOR CH 16V 1U	1	
Q3101	UP05C8B00L	TRANSISTOR	1	E.S.D.
R3101	ERJ2GEJ470	M.RESISTOR CH 1/16W 47	1	
R3102	ERJ2GEJ222	M.RESISTOR CH 1/10W 2.2K	1	
R3107	ERJ2GEJ132	M.RESISTOR CH 1/10W 1.3K	1	
R3108	ERJ2GEJ560X	M.RESISTOR CH 1/10W 56	1	
TH3101	D4CC11030013	THERMISTOR	1	

Ref.No.	Part No.	Part Name & Description	Pcs	Remarks	Ref.No.	Part No.	Part Name & Description	Pcs	Remarks
1	VEP56100B	MAIN P.C.B.	1	EG,EP,EF,EB,PR (RTL) E.S.D.	100	VXW1134	LENS UNIT (W/O CCD)	1	
1	VEP56100A	MAIN P.C.B.	1	EE,SG,P,PC,PU,GC,GH,GT, GK,GN,GD (RTL) E.S.D.	102	VEK0P96	CCD UNIT	1	E.S.D.
2	VEP50058A	SUB OPERATION FPC UNIT	1	(RTL) E.S.D.	103	L6DAACGC0002	ZOOM MOTOR	1	
3	VGQ0K60	SW PCB BASE	1		104	VEK0P53	LENS FPC UNIT	1	
4	VGU0E82	REC/PLAYBACK SELECTOR KNOB	1		104-1	B3NBA0000010	PHOTO SENSOR	1	
5	VMP9597	SW PLATE	1		105	VDW1892	BOTH SIDES CAM FRAME	1	
6	VGQ0G06	TORIPOD	1		106	VDW1893	2ND 3RD DIRECT FRAME	1	
7	VMP9425	FRAME PLATE	1		107	VXP3429	1ST LENS FRAME UNIT	1	
8	VYK3T49	LCD UNIT	1		108	VXP3274	1ST DIRECT FRAME UNIT	1	
10	VYK3V52	LCD PANEL UNIT	1		109	VXP3275	2ND LENS FRAME UNIT	1	
50	VYK3T36	FRONT CASE UNIT	1	EG-S,EP-S,EB-S,EE-S,SG-S, PU-S,GC-S,GH-S,GK-S,GN-S [PAVCSG]	110	VXP3276	3RD LENS FRAME UNIT	1	
50	VYK3T37	FRONT CASE UNIT	1	EG-K,EP-K,EF-K,EB-K,EE-K, PU-K,PR-K,GC-K,GH-K,GT-K, GK-K,GN-K,GD-K [PAVCSG]	111	VXQ1861	FIX/DRIVE/CAM FRAME UNIT	1	
50	VYK3T38	FRONT CASE UNIT	1	(-N) [PAVCSG]	112	VXQ1788	MASTER FLANGE UNIT	1	
50	VYK3T39	FRONT CASE UNIT	1	EG-R,EP-R,EF-R,EB-R,SG-R, PU-R,GC-R,GH-R,GT-R,GK-R, GN-R [PAVCSG]	112-1	L6HA64NC0017	FOCUS MOTOR UNIT	1	
50	VYK3T40	FRONT CASE UNIT	1	(-T) [PAVCSG]	112-2	VMB4299	FOCUS SPRING	1	
50	VYK3T41	FRONT CASE UNIT	1	EG-A,EP-A,EB-A,EE-A,PU-A, GN-A [PAVCSG]	112-3	VXP3284	4TH LENS FRAME UNIT	1	
50	VYK4A08	FRONT CASE UNIT	1	P-S [PAVCSG]	B1	VHD2036	SCREW	1	
50	VYK4A09	FRONT CASE UNIT	1	P-K,PC-K [PAVCSG]	B2	VHD2084	SCREW	1	
50	VYK4A10	FRONT CASE UNIT	1	P-R [PAVCSG]	B3	VHD2084	SCREW	1	
50	VYK4A11	FRONT CASE UNIT	1	P-A,PC-A [PAVCSG]	B4	VHD2084	SCREW	1	
51	VYK3T50	REAR CASE UNIT	1	(-S) [PAVCSG]	B5	VHD2205	SCREW	1	(-S,-N)
51	VYK3T51	REAR CASE UNIT	1	(-K) [PAVCSG]	B5	VHD2206	SCREW	1	(-K,-R,-T,-A)
51	VYK3T52	REAR CASE UNIT	1	(-N) [PAVCSG]	B6	VHD2205	SCREW	1	(-S,-N)
51	VYK3T53	REAR CASE UNIT	1	(-R) [PAVCSG]	B6	VHD2206	SCREW	1	(-K,-R,-T,-A)
51	VYK3T54	REAR CASE UNIT	1	(-T) [PAVCSG]	B7	VHD2207	SCREW	1	(-S,-N)
51	VYK3T55	REAR CASE UNIT	1	(-A) [PAVCSG]	B7	VHD2208	SCREW	1	(-K,-R,-T,-A)
51-1	VGU0F77	CURSOR BUTTON	1	[PAVCSG]	B8	VHD2207	SCREW	1	(-S,-N)
51-2	VMT2025	GYRO CUSHION	1	[PAVCSG]	B8	VHD2208	SCREW	1	(-K,-R,-T,-A)
52	VKH0451	STRAP HOLDER	1	[PAVCSG]	B9	VHD2207	SCREW	1	(-S,-N)
53	VYK3T63	BATTERY DOOR UNIT	1	(-S) [PAVCSG]	B9	VHD2208	SCREW	1	(-K,-R,-T,-A)
53	VYK3T64	BATTERY DOOR UNIT	1	(-K) [PAVCSG]	B10	VHD2207	SCREW	1	(-S,-N)
53	VYK3T65	BATTERY DOOR UNIT	1	(-N) [PAVCSG]	B10	VHD2208	SCREW	1	(-K,-R,-T,-A)
53	VYK3T66	BATTERY DOOR UNIT	1	(-R) [PAVCSG]	B11	VHD2207	SCREW	1	(-S,-N)
53	VYK3T67	BATTERY DOOR UNIT	1	(-T) [PAVCSG]	B11	VHD2208	SCREW	1	(-K,-R,-T,-A)
53	VYK3T68	BATTERY DOOR UNIT	1	(-A) [PAVCSG]	B12	VHD2207	SCREW	1	(-S,-N)
53-1	VMB4143	BATTERY DOOR SPRING	1	[PAVCSG]	B12	VHD2208	SCREW	1	(-K,-R,-T,-A)
53-2	VMS7863	BATTERY DOOR SHAFT	1	[PAVCSG]	B13	VHD2207	SCREW	1	(-S,-N)
54	VGQ0L97	BATTERY LOCK KNOB	1	[PAVCSG]	B13	VHD2208	SCREW	1	(-K,-R,-T,-A)
55	VKF4652	JACK DOOR	1	(-S) [PAVCSG]	B14	VHD2207	SCREW	1	(-S,-N)
55	VKF4653	JACK DOOR	1	(-K) [PAVCSG]	B14	VHD2208	SCREW	1	(-K,-R,-T,-A)
55	VKF4654	JACK DOOR	1	(-N) [PAVCSG]	B15	VHD2207	SCREW	1	(-S,-N)
55	VKF4655	JACK DOOR	1	(-R) [PAVCSG]	B15	VHD2208	SCREW	1	(-K,-R,-T,-A)
55	VKF4656	JACK DOOR	1	(-T) [PAVCSG]	B50	VHD2182	SCREW	1	[PAVCSG]
55	VKF4671	JACK DOOR	1	(-A) [PAVCSG]	B51	VHD2182	SCREW	1	[PAVCSG]
56	VMB4152	BATTERY LOCK SPRING	1	[PAVCSG]	B52	XQN14+BJ8FJK	SCREW	1	[PAVCSG]
57	VMB4305	BATTERY OUT SPRING	1	[PAVCSG]	B101	VHD1871	SCREW	1	
58	VMP9595	FRAME	1	[PAVCSG]	B102	VHD1871	SCREW	1	
59	VMP9596	BATTERY CASE	1	[PAVCSG]	B103	VHD1871	SCREW	1	
60	VMS8049-A	JACK DOOR SHAFT	1	[PAVCSG]	B104	VHD2011	SCREW	1	
61	VGL1290	AF PANEL LIGHT	1	[PAVCSG]	B105	XQN14+BJ4FNK	SCREW	1	
62	VGQ0G09	CAPACITOR PCB HOLDER	1	[PAVCSG]	B106	XQN14+BJ4FNK	SCREW	1	
63	VMP9427	TOP PLATE (R)	1	[PAVCSG]	B107	XQN14+BJ4FNK	SCREW	1	
64	EFN-AMAM2AZD	FLASH	1	[PAVCSG]	B108	XQN14+BJ4FNK	SCREW	1	
△ 65	F2A2F8500004	E. CAPACITOR	1	[PAVCSG] (C8503)	B109	XQN14+BJ4FNK	SCREW	1	
66	L0AA01A00032	SPEAKER	1	[PAVCSG]	B110	XQN14+BJ4FNK	SCREW	1	
△ 67	ML-421S/ZTN	BUTTON BATTERY	1	[ENERGY] (B8001)	B111	XQN14+BJ4FNK	SCREW	1	
70	VEK0Q27	FLASH TOP P.C.B.	1	(RTL) [PAVCSG] E.S.D.					
71	VEP58111A	E. CAPACITOR P.C.B.	1	[PAVCSG]					
72	VMB4149	EARTH SPRING	1	[PAVCSG] (ET8503)					
73	VMP9594	TOP PLATE (L)	1	[PAVCSG] (ET8011)					
74	VMT1968	MIC DAMPER	1	[PAVCSG]					
75	VMT2039	MIC CUSHION	1	[PAVCSG]					
76	VYK3T77	TOP CASE UNIT	1	(DMC-ZX3) [PAVCSG]					
76	VYK3T78	TOP CASE UNIT	1	(DMC-ZR3) [PAVCSG]					
76-1	VGQ0G07	POWER KNOB BASE	1	[PAVCSG]					
76-2	VGU0F42	POWER KONB	1	[PAVCSG]					

Ref.No.	Part No.	Part Name & Description	Pcs	Remarks
300	VPF1301	CAMERA BAG	1	(EXCEPT P,PC) [PAVCSG]
△ 301	DE-A66AA	BATTERY CHARGER	1	EG,EP,EF,EB,GN
△ 301	DE-A66BB	BATTERY CHARGER	1	EE,GC,GH,GK,GD
△ 301	DE-A66EA	BATTERY CHARGER	1	SG
△ 301	DE-A66DA	BATTERY CHARGER	1	PR
△ 301	DE-A66CA	BATTERY CHARGER	1	GT
△ 301	DE-A65BA	BATTERY CHARGER	1	PU
△ 302	----	BATTERY	1	(EXCEPT P,PC)
304	K1HA08AD0002	USB CABLE W/PLUG	1	(EXCEPT P,PC)
305	K1HA08CD0028	AV CABLE W/PLUG	1	(EXCEPT P,PC)
306	VFC4297	HAND STRAP	1	(EXCEPT P,PC)
308	VGQ0E45	BATTERY PROTECTION CASE	1	(EXCEPT P,PC)
310	VPF1230	BAG, POLYETHYLENE	1	(EXCEPT P,PC)
△ 311	VFF0583-S	CD-ROM	1	EG,EP,EF,EB
		(SOFTWARE/INSTRUCTION BOOK)		See "Notes"
△ 311	VFF0584-S	CD-ROM	1	EE,SG
		(SOFTWARE/INSTRUCTION BOOK)		See "Notes"
△ 311	VFF0585-S	CD-ROM	1	GC,GH,GN
		(SOFTWARE/INSTRUCTION BOOK)		See "Notes"
△ 311	VFF0586-S	CD-ROM	1	GT,GD
		(SOFTWARE/INSTRUCTION BOOK)		See "Notes"
△ 311	VFF0587-S	CD-ROM	1	GK
		(SOFTWARE/INSTRUCTION BOOK)		See "Notes"
△ 311	VFF0582-S	CD-ROM	1	PU,PR
		(SOFTWARE/INSTRUCTION BOOK)		See "Notes"
△ 312	VQT2L97	SIMPLIFIED O/I	1	EG
		(ERMAN/FRENCH)		
△ 312	VQT2L98	SIMPLIFIED O/I	1	EG
		(ITALIAN/DUTCH)		
△ 312	VQT2L99	SIMPLIFIED O/I	1	EG
		(SPANISH/PORTUGUESE)		
△ 312	VQT2M00	SIMPLIFIED O/I	1	EG
		(TURKISH)		
△ 312	VQT2M01	SIMPLIFIED O/I	1	EP
		(SWEDISH/DANISH)		
△ 312	VQT2M02	SIMPLIFIED O/I	1	EP
		(POLISH/CZECH)		
△ 312	VQT2M03	SIMPLIFIED O/I	1	EP
		(HUNGARIAN/FINNISH)		
△ 312	VQT2M04	SIMPLIFIED O/I	1	EF
		(FRENCH)		
△ 312	VQT2M05	SIMPLIFIED O/I	1	EB
		(ENGLISH)		
△ 312	VQT2M06	SIMPLIFIED O/I	1	EE
		(RUSSIAN/UKRAINIAN)		
△ 312	VQT2M07	SIMPLIFIED O/I	1	SG,GC,GH
		(ENGLISH/ CHINESE(TRADITIONAL))		
△ 312	VQT2L95	SIMPLIFIED O/I	1	PU
		(SPANISH/PORTUGUESE)		
△ 312	VQT2L96	SIMPLIFIED O/I	1	PR
		(SPANISH)		
△ 312	VQT2M08	SIMPLIFIED O/I	1	GC
		(ARABIC/PERSIAN)		
△ 312	VQT2M09	SIMPLIFIED O/I	1	GT
		(CHINESE(TRADITIONAL))		
△ 312	VQT2M10	SIMPLIFIED O/I	1	GK
		(CHINESE(SIMPLIFIED))		
△ 312	VQT2M11	SIMPLIFIED O/I	1	GN
		(ENGLISH)		
△ 312	VQT2M12	SIMPLIFIED O/I	1	GD
		(KOREAN)		
313	VQT2L83	O/I SOFTWARE	1	EG
		(GERMAN/FRENCH/ITALIAN/ DUTCH/SPANISH/PORTUGUESE/ TURKISH)		
313	VQT2L84	O/I SOFTWARE	1	EP
		(FINNISH/SWEDISH/DANISH/ POLISH/CZECH/HUNGARIAN)		
313	VQT2L85	O/I SOFTWARE	1	EF
		(FRENCH)		
313	VQT2L86	O/I SOFTWARE	1	EB,GN
		(ENGLISH)		
313	VQT2L87	O/I SOFTWARE	1	EE
		(RUSSIAN/UKRAINIAN)		

Ref.No.	Part No.	Part Name & Description	Pcs	Remarks
313	VQT2L88	O/I SOFTWARE	1	SG,GC,GH
		(ENGLISH/ CHINESE(TRADITIONAL)/ ARABIC/PERSIAN)		
313	VQT2L82	O/I SOFTWARE	1	PU,PR
		(SPANISH/PORTUGUESE)		
313	VQT2L89	O/I SOFTWARE	1	GT
		(CHINESE(TRADITIONAL))		
313	VQT2L90	O/I SOFTWARE	1	GK
		(CHINESE(SIMPLIFIED))		
313	VQT2L91	O/I SOFTWARE	1	GD
		(KOREAN)		
314	VPK4302	PACKING CASE	1	EG-S,EP-S,EB-S,EE-S,SG-S
314	VPK4306	PACKING CASE	1	EG-K,EP-K,EF-K,EB-K,EE-K
314	VPK4311	PACKING CASE	1	EG-R,EP-R,EF-R,EB-R,SG-R
314	VPK4318	PACKING CASE	1	EG-T,EP-T,EF-T,SG-T
314	VPK4315	PACKING CASE	1	EG-A,EP-A,EB-A,EE-A
314	VPK4377	PACKING CASE	1	SG-N
314	VPK4303	PACKING CASE	1	PU-S,GC-S,GH-S,GN-S
314	VPK4307	PACKING CASE	1	PU-K,PR-K,GC-K,GH-K,GT-K, GN-K,GD-K
314	VPK4312	PACKING CASE	1	PU-R,GC-R,GH-R,GT-R,GN-R
314	VPK4316	PACKING CASE	1	PU-A,GN-A
314	VPK4321	PACKING CASE	1	GC-N,GH-N,GT-N
314	VPK4319	PACKING CASE	1	GH-T,GN-T,GD-T
314	VPK4304	PACKING CASE	1	GK-S
314	VPK4308	PACKING CASE	1	GK-K
314	VPK4378	PACKING CASE	1	GK-R
315	VPN6986	CUSHION	1	EG,EP,EF,EB,EE,SG,PU,PR, GC,GH,GT,GK,GN,GD
318	VQL2C68	OPERATING LABEL	1	GT
△ 319	K2CT39A00002	AC CORD W/PLUG	1	EB,GC,GH
△ 320	K2CQ29A00002	AC CORD W/PLUG	1	EG,EP,EF,EE,GC
△ 320	K2CR29A00001	AC CORD W/PLUG	1	GD
△ 321	K2CJ29A00002	AC CORD W/PLUG	1	GN
△ 322	K2CA29A00023	AC CORD W/PLUG	1	SG
△ 322	K2CA29A00021	AC CORD W/PLUG	1	GT
△ 322	K2CA2YY00070	AC CORD W/PLUG	1	GK
△ 324	K2CJ29A00003	AC CORD W/PLUG	1	PR

S7.2. Packing Parts and Accessories Section (1)

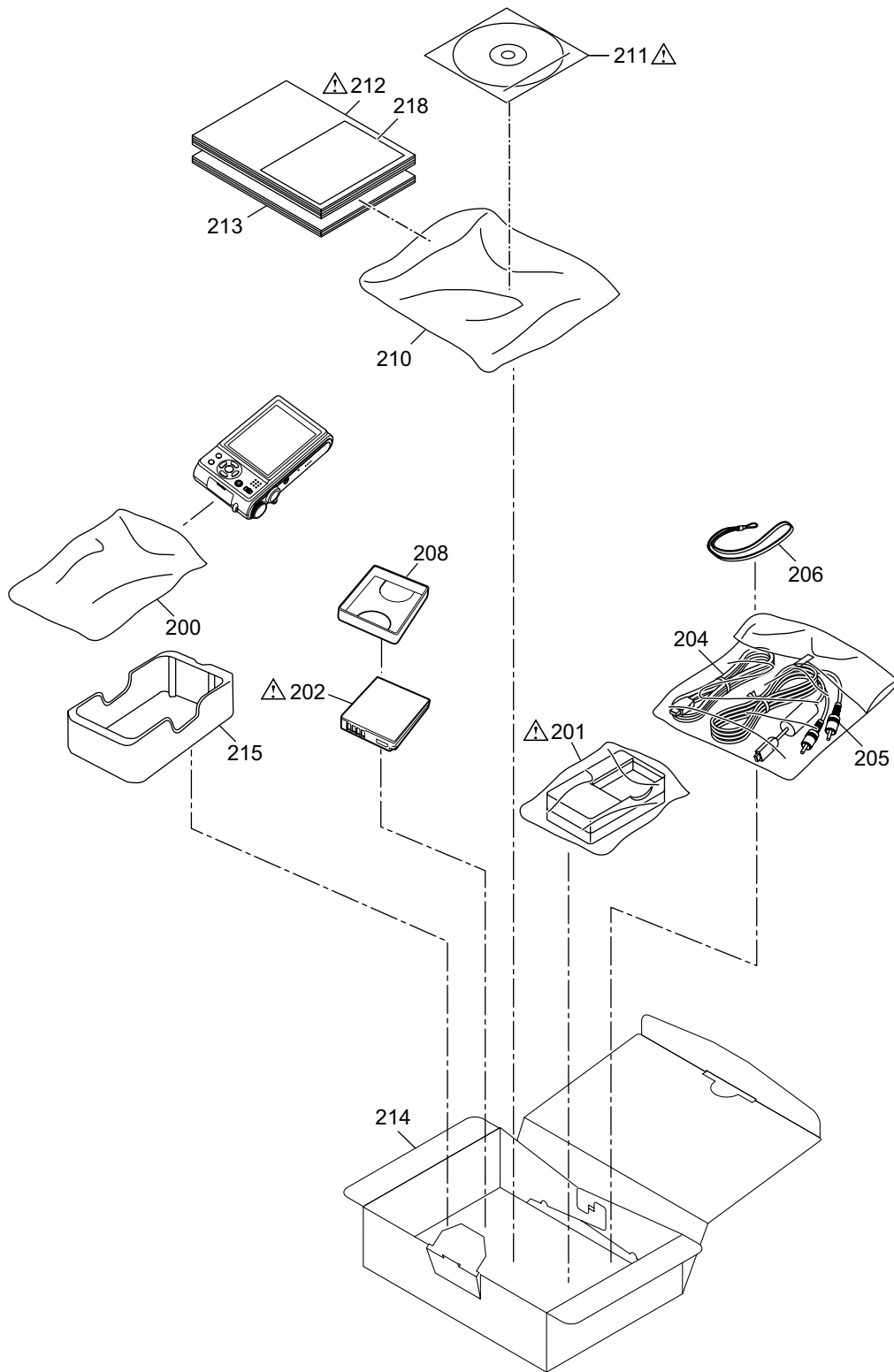

S7.3. Packing Parts and Accessories Section (2)

