

Service Manual

Digital Camera

LUMIX  HDMI
VIERA Link™

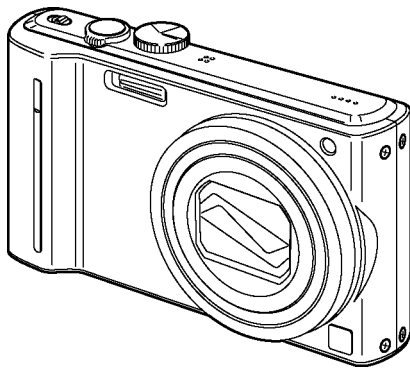

Model No. **DMC-TZ8EB**
DMC-TZ8EE
DMC-TZ8EF
DMC-TZ8EG
DMC-TZ8EP
DMC-TZ8GC
DMC-TZ8GN
DMC-ZS5P
DMC-ZS5PC
DMC-ZS5PU
DMC-ZS5GH
DMC-ZS5GK

VOL.1

Colours

(S).....Silver Type (except DMC-TZ8EF)

(K).....Black Type

WARNING

This service information is designed for experienced repair technicians only and is not designed for use by the general public. It does not contain warnings or cautions to advise non-technical individuals of potential dangers in attempting to service a product. Products powered by electricity should be serviced or repaired only by experienced professional technicians. Any attempt to service or repair the product or products dealt with in this service information by anyone else could result in serious injury or death.

Panasonic®

© Panasonic Corporation 2010.
Unauthorized copying and distribution is a violation
of law.

TABLE OF CONTENTS

	PAGE	PAGE
1 Safety Precautions	3	
1.1. General Guidelines	3	
1.2. Leakage Current Cold Check	3	
1.3. Leakage Current Hot Check (See Figure 1).....	3	
1.4. How to Discharge the Capacitor on Flash P.C.B.....	4	
2 Warning	5	
2.1. Prevention of Electrostatic Discharge (ESD) to Electrostatic Sensitive (ES) Devices	5	
2.2. How to Recycle the Lithium Ion Battery (U.S. Only).....	5	
2.3. Caution for AC Cord (For EB/GC/GH).....	6	
2.4. How to Replace the Lithium Battery.....	7	
3 Service Navigation	9	
3.1. Introduction	9	
3.2. General Description About Lead Free Solder (PbF)	9	
3.3. Important Notice 1:(Other than U.S.A. and Canadian Market)	9	
3.4. How to Define the Model Suffix (NTSC or PAL model).....	10	
4 Specifications	13	
5 Location of Controls and Components	15	
6 Service Mode	17	
6.1. Error Code Memory Function	17	
6.2. ICS (Indication of additional Camera Settings when picture was taken) function	21	
7 Service Fixture & Tools	23	
7.1. Service Fixture and Tools	23	
7.2. When Replacing the Main P.C.B.	23	
7.3. Service Position	24	
8 Disassembly and Assembly Instructions	25	
8.1. Disassembly Flow Chart.....	25	
8.2. P.C.B. Location	25	
8.3. Disassembly Procedure	26	
8.4. Lens Disassembly Procedure.....	32	
8.5. Assembly Procedure for Lens	35	
8.6. Removal of the CCD Unit	39	
8.7. Removal of the Zoom Motor Unit	39	
8.8. Removal of the Focus Motor Unit.....	40	
8.9. The Aplyment of Grease Method.....	40	
9 Measurements and Adjustments	41	
9.1. Introduction	41	
9.2. Before Disassembling the unit.....	41	
9.3. Details of Electrical Adjustment.....	43	
9.4. After Adjustment.....	47	
10 Maintenance	48	
10.1. Cleaning Lens, Viewfinder and LCD Panel.....	48	

1 Safety Precautions

1.1. General Guidelines

1. IMPORTANT SAFETY NOTICE

There are special components used in this equipment which are important for safety. These parts are marked by  in the Schematic Diagrams, Circuit Board Layout, Exploded Views and Replacement Parts List. It is essential that these critical parts should be replaced with manufacturer's specified parts to prevent X-RADIATION, shock fire, or other hazards. Do not modify the original design without permission of manufacturer.

2. An Isolation Transformer should always be used during the servicing of AC Adaptor whose chassis is not isolated from the AC power line. Use a transformer of adequate power rating as this protects the technician from accidents resulting in personal injury from electrical shocks. It will also protect AC Adaptor from being damaged by accidental shorting that may occur during servicing.
3. When servicing, observe the original lead dress. If a short circuit is found, replace all parts which have been overheated or damaged by the short circuit.
4. After servicing, see to it that all the protective devices such as insulation barriers, insulation papers shields are properly installed.
5. After servicing, make the following leakage current checks to prevent the customer from being exposed to shock hazards.

1.2. Leakage Current Cold Check

1. Unplug the AC cord and connect a jumper between the two prongs on the plug.
2. Measure the resistance value, with an ohmmeter, between the jumpered AC plug and each exposed metallic cabinet part on the equipment such as screwheads, connectors, control shafts, etc. When the exposed metallic part has a return path to the chassis, the reading should be between $1M\Omega$ and $5.2M\Omega$. When the exposed metal does not have a return path to the chassis, the reading must be infinity.

1.3. Leakage Current Hot Check (See Figure 1)

1. Plug the AC cord directly into the AC outlet. Do not use an isolation transformer for this check.
2. Connect a $1.5k\Omega$, 10 W resistor, in parallel with a $0.15\mu F$ capacitor, between each exposed metallic part on the set and a good earth ground, as shown in Figure 1.
3. Use an AC voltmeter, with $1 k\Omega/V$ or more sensitivity, to measure the potential across the resistor.
4. Check each exposed metallic part, and measure the voltage at each point.
5. Reverse the AC plug in the AC outlet and repeat each of the above measurements.
6. The potential at any point should not exceed 0.75 V RMS. A leakage current tester (Simpson Model 229 or equivalent) may be used to make the hot checks, leakage current must not exceed $1/2$ mA. In case a measurement is outside of the limits specified, there is a possibility of a shock hazard, and the equipment should be repaired and rechecked before it is returned to the customer.

Hot-Check Circuit

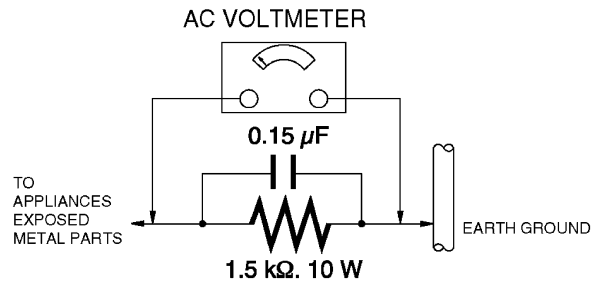

Figure 1

1.4. How to Discharge the Capacitor on Flash P.C.B.

CAUTION:

1. Be sure to discharge the capacitor on Flash P.C.B.
2. Be careful of the high voltage circuit on Flash P.C.B. when servicing.

[Discharging Procedure]

1. Refer to the disassemble procedure and remove the necessary parts/unit.
2. Install the insulation tube onto the lead part of Resistor (ERG5SJ102:1k Ω /5W).
(an equivalent type of resistor may be used.)
3. Place a resistor between both terminals of capacitor on the Flash P.C.B. for approx. 5 seconds.
4. After discharging, confirm that the capacitor voltage is lower than 10V using a voltmeter.

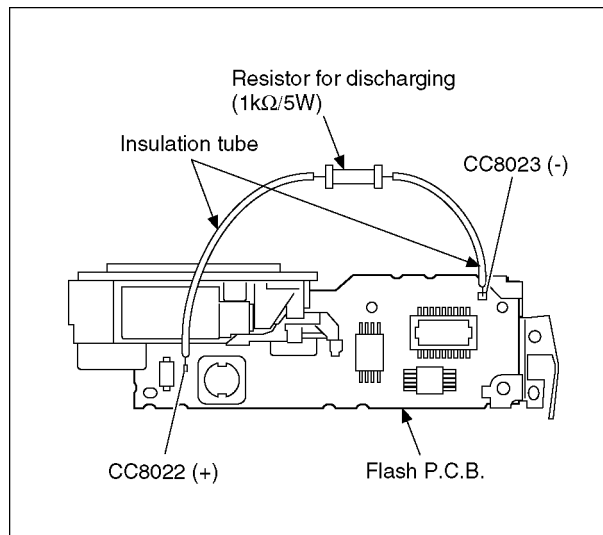

Fig. F1

2 Warning

2.1. Prevention of Electrostatic Discharge (ESD) to Electrostatic Sensitive (ES) Devices

Some semiconductor (solid state) devices can be damaged easily by static electricity. Such components commonly are called Electrostatically Sensitive (ES) Devices.

Examples of typical ES devices are CCD image sensor, IC (integrated circuits) and some field-effect transistors and semiconductor "chip" components.

The following techniques should be used to help reduce the incidence of component damage caused by electrostatic discharge (ESD).

1. Immediately before handling any semiconductor component or semiconductor-equipped assembly, drain off any ESD on your body by touching a known earth ground. Alternatively, obtain and wear a commercially available discharging ESD wrist strap, which should be removed for potential shock reasons prior to applying power to the unit under test.
2. After removing an electrical assembly equipped with ES devices, place the assembly on a conductive surface such as aluminum foil, to prevent electrostatic charge buildup or exposure of the assembly.
3. Use only a grounded-tip soldering iron to solder or unsolder ES devices.
4. Use only an antistatic solder removal device. Some solder removal devices not classified as **antistatic (ESD protected)** can generate electrical charge sufficient to damage ES devices.
5. Do not use freon-propelled chemicals. These can generate electrical charges sufficient to damage ES devices.
6. Do not remove a replacement ES device from its protective package until immediately before you are ready to install it. (Most replacement ES devices are packaged with leads electrically shorted together by conductive foam, aluminum foil or comparable conductive material).
7. Immediately before removing the protective material from the leads of a replacement ES device, touch the protective material to the chassis or circuit assembly into which the device will be installed.

CAUTION:

Be sure no power is applied to the chassis or circuit, and observe all other safety precautions.

8. Minimize bodily motions when handling unpackaged replacement ES devices. (Otherwise harmless motion such as the brushing together of your clothes fabric or the lifting of your foot from a carpeted floor can generate static electricity (ESD) sufficient to damage an ES device).

2.2. How to Recycle the Lithium Ion Battery (U.S. Only)

ENGLISH



A lithium ion/polymer battery that is recyclable powers the product you have purchased. Please call 1-800-8-BATTERY for information on how to recycle this battery.

FRANÇAIS



L'appareil que vous vous êtes procuré est alimenté par une batterie au lithium-ion/polymère recyclable. Pour des renseignements sur le recyclage de la batterie, veuillez composer le 1-800-8-BATTERY.

2.3. Caution for AC Cord (For EB/GC/GH)

2.3.1. Information for Your Safety

IMPORTANT

Your attention is drawn to the fact that recording of pre-recorded tapes or discs or other published or broadcast material may infringe copyright laws.

WARNING

To reduce the risk of fire or shock hazard, do not expose this equipment to rain or moisture.

CAUTION

To reduce the risk of fire or shock hazard and annoying interference, use the recommended accessories only.

FOR YOUR SAFETY

DO NOT REMOVE THE OUTER COVER

To prevent electric shock, do not remove the cover. No user serviceable parts inside. Refer servicing to qualified service personnel.

2.3.2. Caution for AC Mains Lead

For your safety, please read the following text carefully.

This appliance is supplied with a moulded three-pin mains plug for your safety and convenience.

A 5-ampere fuse is fitted in this plug.

Should the fuse need to be replaced please ensure that the replacement fuse has a rating of 5 amperes and it is approved by ASTA or BSI to BS1362

Check for the ASRA mark or the BSI mark on the body of the fuse.



If the plug contains a removable fuse cover you must ensure that it is refitted when the fuse is replaced.

If you lose the fuse cover, the plug must not be used until a replacement cover is obtained.

A replacement fuse cover can be purchased from your local Panasonic Dealer.

If the fitted moulded plug is unsuitable for the socket outlet in your home then the fuse should be removed and the plug cut off and disposed of safely.

There is a danger of severe electrical shock if the cut off plug is inserted into any 13-ampere socket.

If a new plug is to be fitted please observe the wiring code as shown below.

If in any doubt, please consult a qualified electrician.

2.3.2.1. Important

The wires in this mains lead are coloured in accordance with the following code:

Blue	Neutral
Brown	Live

As the colours of the wires in the mains lead of this appliance may not correspond with the coloured markings identifying the terminals in your plug, proceed as follows:

The wire which is coloured BLUE must be connected to the terminal in the plug which is marked with the letter N or coloured BLACK.

The wire which is coloured BROWN must be connected to the terminal in the plug which is marked with the letter L or coloured RED.

Under no circumstances should either of these wires be connected to the earth terminal of the three pin plug, marked with the letter E or the Earth Symbol.

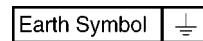

2.3.2.2. Before Use

remove the Connector Cover as follows.

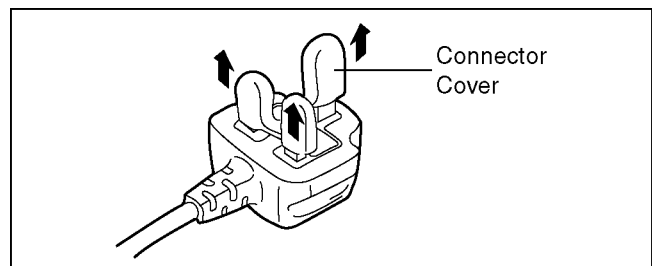

2.3.2.3. How to Replace the Fuse

1. Remove the Fuse Cover with a screwdriver.

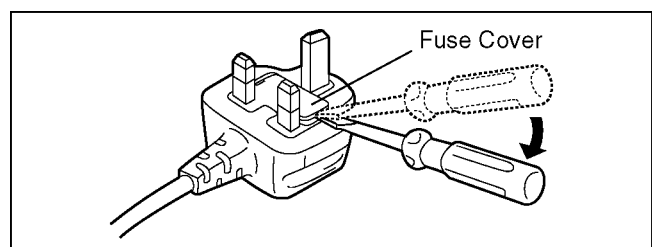

2. Replace the fuse and attach the Fuse cover.

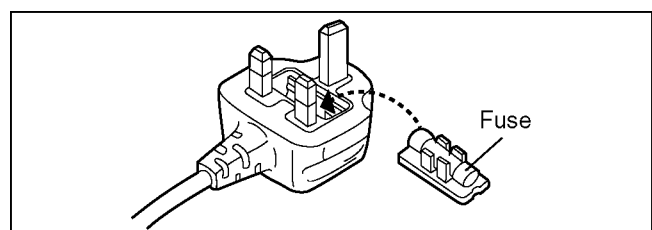

2.4. How to Replace the Lithium Battery

2.4.1. Replacement Procedure

1. Remove the SD Card P.C.B. (Refer to Disassembly Procedures.)
2. Remove the Lithium battery (Ref. No. **ZB9901** at foil side of SD Card P.C.B.) and then replace it into new one.

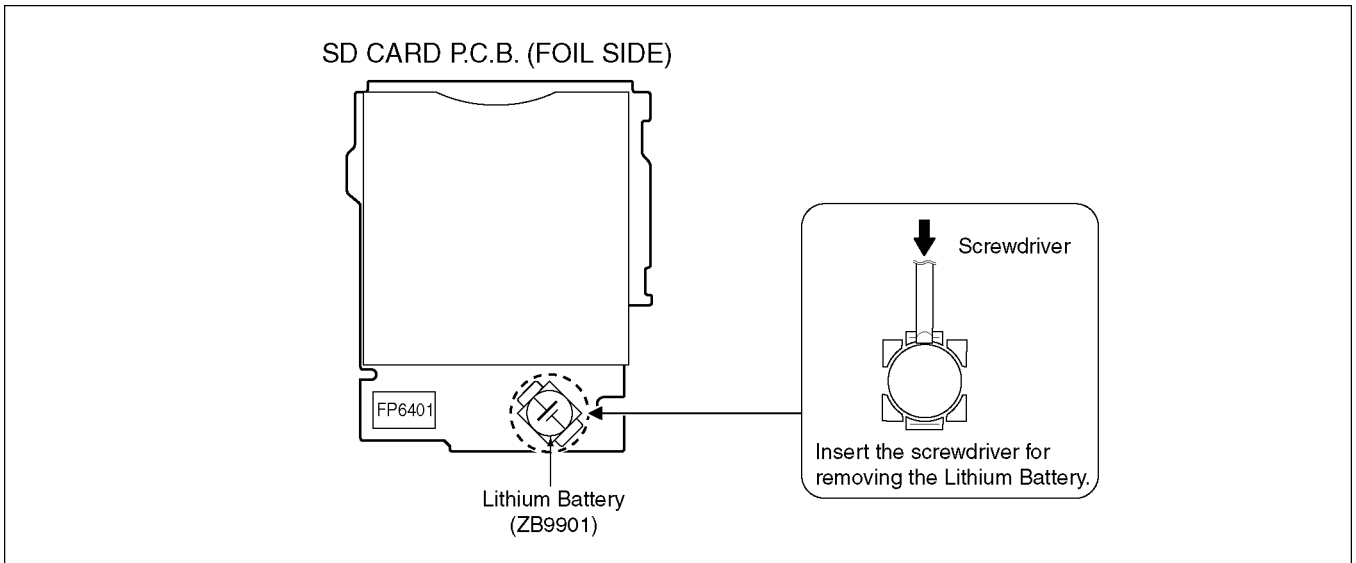

CAUTION

Danger of explosion if battery is incorrectly replaced.
Replace only with the same or equivalent type.

CAUTION

The battery used in this device may present a risk of fire or chemical burn if mistreated.
Do not recharge, disassemble, heat above 100°C (212°F), or incinerate.
Replace battery with Panasonic part number ML-421S/ZTK only.
Use of another battery may present a risk of fire or explosion.
Dispose of used battery promptly.
Keep away from children.
Do not disassemble and do not dispose of in fire.

Note:

The lithium battery is a critical component.

(Type No.: ML-421S/ZTK **Manufactured by Energy Company, Panasonic Corporation.**)

It must never be subjected to excessive heat or discharge.

It must therefore only be fitted in equipment designed specifically for its use.

Replacement batteries must be of the same type and manufacture.

They must be fitted in the same manner and location as the original battery, with the correct polarity contacts observed.

Do not attempt to re-charge the old battery or re-use it for any other purpose.

It should be disposed of in waste products destined for burial rather than incineration.

(For English)

CAUTION

Danger of explosion if battery is incorrectly replaced.
Replace only with the same or equivalent type recommended by the manufacturer.
Dispose of used batteries according to the manufacturer's instructions.

(For German)

ACHTUNG

Explosionsgefahr bei falschem Anbringen der Batterie. Ersetzen Sie nur mit einem äquivalentem vom Hersteller empfohlenem Typ.
Behandeln Sie gebrauchte Batterien nach den Anweisungen des Herstellers.

(For French)

MISE EN GARDE

Une batterie de remplacement inappropriée peut exploser. Ne remplacez qu'avec une batterie identique ou d'un type recommandé par le fabricant. L'élimination des batteries usées doit être faite conformément aux instructions du fabricant.

Note:

Above caution is applicable for a battery pack which is for DMC-TZ8/ZS5 series, as well.

3 Service Navigation

3.1. Introduction

This service manual contains technical information, which will allow service personnel's to understand and service this model. Please place orders using the parts list and not the drawing reference numbers. If the circuit is changed or modified, the information will be followed by service manual to be controlled with original service manual.

3.2. General Description About Lead Free Solder (PbF)

The lead free solder has been used in the mounting process of all electrical components on the printed circuit boards used for this equipment in considering the globally environmental conservation.

The normal solder is the alloy of tin (Sn) and lead (Pb). On the other hand, the lead free solder is the alloy mainly consists of tin (Sn), silver (Ag) and Copper (Cu), and the melting point of the lead free solder is higher approx.30 °C (86 °F) more than that of the normal solder.

Definition of PCB Lead Free Solder being used

The letter of PbF is printed either foil side or components side on the P.C.B. using the lead free solder. (See right figure)

PbF

Service caution for repair work using Lead Free Solder (PbF)

- The lead free solder has to be used when repairing the equipment for which the lead free solder is used.
- (Definition: The letter of **PbF** is printed on the P.C.B. using the lead free solder.)
- To put lead free solder, it should be well molten and mixed with the original lead free solder.
- Remove the remaining lead free solder on the P.C.B. cleanly for soldering of the new IC.
- Since the melting point of the lead free solder is higher than that of the normal lead solder, it takes the longer time to melt the lead free solder.
- Use the soldering iron (more than 70W) equipped with the temperature control after setting the temperature at 350±30 degrees C (662±86 °F).

Recommended Lead Free Solder (Service Parts Route.)

- The following 3 types of lead free solder are available through the service parts route.
 - RFKZ03D01KS-----(0.3mm 100g Reel)
 - RFKZ06D01KS-----(0.6mm 100g Reel)
 - RFKZ10D01KS-----(1.0mm 100g Reel)

Note:

* Ingredient: tin (Sn) 96.5%, silver (Ag) 3.0%, Copper (Cu) 0.5%, Cobalt (Co) / Germanium (Ge) 0.1 to 0.3%

3.3. Important Notice 1:(Other than U.S.A. and Canadian Market)

1. The service manual does not contain the following information, because of the impossibility of servicing at component level without concerned equipment/facilities.
 - a. Schematic diagram, Block Diagram and P.C.B. layout of MAIN P.C.B.
 - b. Parts list for individual parts for MAIN P.C.B.When a part replacement is required for repairing MAIN P.C.B., replace as an assembled parts. (MAIN P.C.B.)
2. The following category is/are recycle module part. please send it/them to Central Repair Center.
 - MAIN P.C.B.: VEP56102A

3.4. How to Define the Model Suffix (NTSC or PAL model)







There are six kinds of DMC-TZ8/ZS5, regardless of the colours.

- a) DMC-ZS5P/PC
- b) DMC-TZ8EB/EF/EG/EP
- c) DMC-TZ8EE
- d) DMC-TZ8GN
- e) DMC-ZS5GK
- f) DMC-TZ8GC, ZS5GH/PU

What is the difference is that the "INITIAL SETTINGS" data which is stored in Flash ROM mounted on Main P.C.B.

3.4.1. Defining methods

To define the model suffix to be serviced, refer to the nameplate which is putted on the bottom side of the Unit.

<p>a) DMC-ZS5P/PC The nameplate for these models show the following Safety registration mark.</p> 	
<p>b) DMC-TZ8EB/EF/EG/EP The nameplate for these models show the following Safety registration mark.</p> 	
<p>c) DMC-TZ8EE The nameplate for this model show the following Safety registration mark.</p> 	<p>e) DMC-ZS5GK The nameplate for these models show the following Safety registration mark.</p> 
<p>d) DMC-TZ8GN The nameplate for these models show the following Safety registration mark.</p> 	<p>f) DMC-TZ8GC, DMC-ZS5GH/PU The nameplate for these models do not show any above safety registration mark.</p>

Note:

After replacing the MAIN P.C.B., be sure to achieve adjustment.

The Maintenance software (DIAS) is available at "software download" on the "Support Information from NWBG/VDBG-AVC" web-site in "TSN system".

3.4.2. INITIAL SETTINGS:

After replacing the MAIN P.C.B., make sure to perform the initial settings after achieving the adjustment by ordering the following procedure in accordance with model suffix of the unit.

1. IMPORTANT NOTICE:

Before proceeding Initial settings, be sure to read the following CAUTIONS.

CAUTION 1:(INITIAL SETTINGS)

--- AFTER REPLACING THE MAIN P.C.B. ---

*.The model suffix can be chosen **JUST ONE TIME.**

(Model suffix : DMC-TZ8; "EB/EE/EF/EG/EP/GC/GN ", DMC-ZS5; "GH/GK/P/PC/PU")

*.Once one of the model suffix has been chosen, the model suffix lists will not be displayed, thus, it can not be changed.

[Note:Only for "EG, EF, EB and EP" models]

*.When one of the "EG, EF, EB and EP" has been chosen, only "EG, EF, EB and EP" are displayed from second times.

CAUTION 2:(Stored picture image data in the unit)

This unit employs "Built-in Memory" for picture image data recording. (Approx.40MB)

After proceeding "INITIAL SETTINGS", the picture image data stored in the unit is erased.

2. PROCEDURES:

• Precautions: Read the above "CAUTION 1" and "CAUTION 2", carefully.

• Preparation:

1. Attach the Battery or AC Adaptor with a DC coupler to the unit.

2. Set the mode dial to the PROGRAM AE mode.

Note: If the mode dial position is other than PROGRAM AE mode, it does not display the initial settings menu.

• **Step 1. The temporary cancellation of "INITIAL SETTINGS":**

Set the REC/PLAYBACK selector switch to "REC (Camera mark)".

While keep pressing "UP of Cursor button" and DISPLAY button simultaneously, turn the Power on.

• **Step 2. The cancellation of "INITIAL SETTINGS":**

Set the REC/PLAYBACK selector switch to "PLAYBACK".

Press "UP of Cursor button" and [DISPLAY button simultaneously, then turn the Power off.

• **Step 3. Turn the Power on:**

Set the REC/PLAYBACK selector switch to "REC (Camera mark)", and then turn the Power on.

• **Step 4. Display the "INITIAL SETTINGS" menu:**

Note: If the unit is other than PROGRAM AE mode, it does not display the initial settings menu.

While keep pressing MENU/SET and "RIGHT of Cursor button" simultaneously, turn the Power off.

The "INITIAL SETTINGS" menu is displayed.

There are two kinds of "INITIAL SETTINGS" menu form as follows:

[CASE 1. After replacing MAIN P.C.B.]

When MAIN P.C.B. has just been replaced, all of the model suffix are displayed as follows. (Five pages in total)

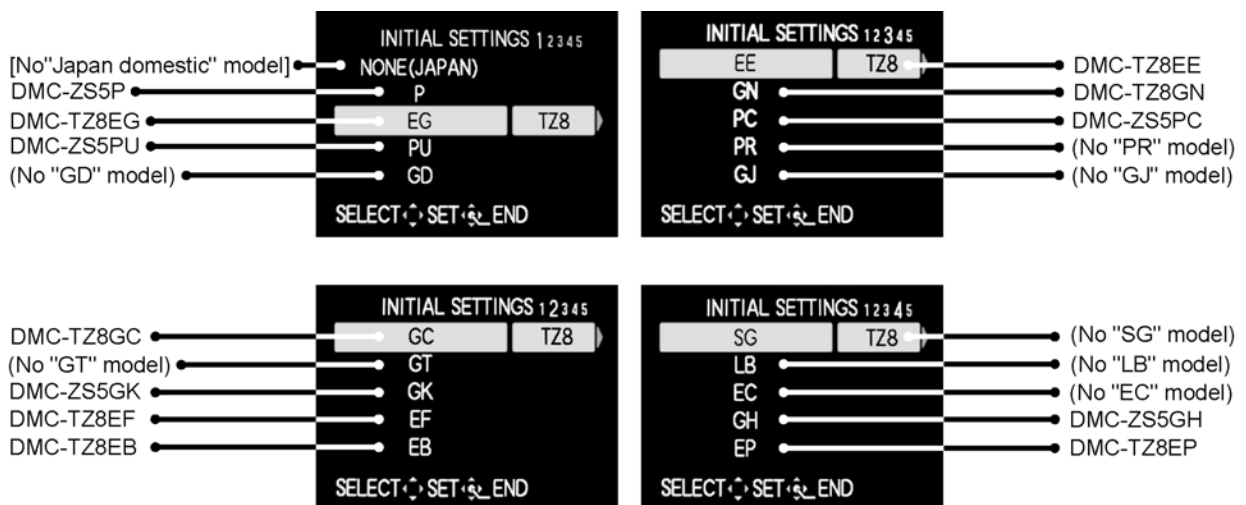

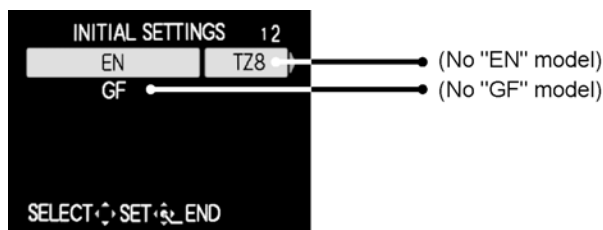

[CASE 2. Other than "After replacing MAIN P.C.B."]

< Other than "EG/EF/EB/EP" models >

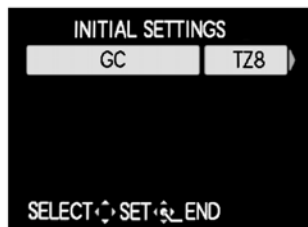

< Only "EG/EF/EB/EP" models >

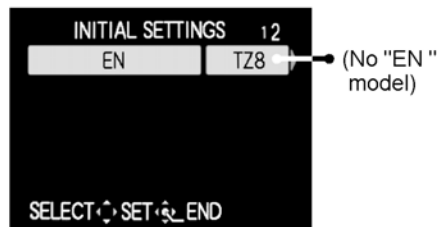

- **Step 5. Chose the model suffix in "INITIAL SETTINGS":** (Refer to "CAUTION 1")

[Caution: After replacing MAIN P.C.B.]

(Especially, other than "EG, EF, EB and EP" models).

The model suffix can be chosen, JUST ONE TIME.

Once one of the model suffix have been chosen, the model suffix lists will not be displayed, thus, it can be changed.

Therefore, select the area carefully.

Select the area with pressing "UP / DOWN of Cursor buttons".

- **Step 6. Set the model suffix at "INITIAL SETTINGS":**

Press the "RIGHT" of Cursor buttons".

The only set area is displayed. Press the "RIGHT" of Cursor buttons" after confirmation.

(The unit is powered off automatically.)

- **Step 7. CONFIRMATION:**

Confirm the display of "PLEASE SET THE CLOCK" in concerned language when the unit is turned on again.

When the unit is connected to PC with USB cable, it is detected as removable media.

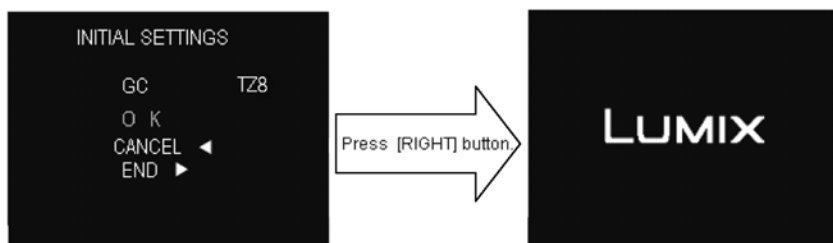

1) As for your reference, major default setting condition is as shown in the following table.

Default setting (After "INITIAL SETTINGS")

	MODEL	VIDEO OUTPUT	LANGUAGE	DATE	REMARKS
a)	DMC-TZ8EB	PAL	English	Date/Month/Year	
b)	DMC-TZ8EE	PAL	Russian	Date/Month/Year	
c)	DMC-TZ8EF	PAL	French	Date/Month/Year	
d)	DMC-TZ8EG	PAL	English	Date/Month/Year	
e)	DMC-TZ8EP	PAL	English	Date/Month/Year	
f)	DMC-TZ8GC	PAL	English	Date/Month/Year	
g)	DMC-TZ8GN	PAL	English	Date/Month/Year	
h)	DMC-ZS5GH	PAL	English	Date/Month/Year	
i)	DMC-ZS5GK	PAL	Chinese (simplified)	Year/Month/Date	No Underwater mode.
j)	DMC-ZS5P	NTSC	English	Month/Date/Year	
k)	DMC-ZS5PC	NTSC	English	Month/Date/Year	
l)	DMC-ZS5PU	NTSC	Spanish	Month/Date/Year	

4 Specifications

Digital Camera: Information for your safety

Power Source	DC 5.1 V
Power Consumption	When recording: 1.1 W When playing back: 0.6 W
Camera effective pixels	12,100,000 pixels
Image sensor	1/2.33" CCD, total pixel number 14,500,000 pixels Primary color filter
Lens	Optical 12 x zoom f=4.1 mm to 49.2 mm (35 mm film camera equivalent: 25 mm to 300 mm)/ F3.3 to F4.9
Digital Zoom	Max. 4 x
Extended Optical Zoom	Max. 23.4 x
Focus range	
P/A/S/M	50 cm (1.64 feet) (Wide)/ 2 m (6.56 feet) (Tele) to ∞
Macro/ Intelligent Auto/ Clipboard/ Motion picture	3 cm (0.10 feet) (Wide)/1 m (3.28 feet) (Tele) to ∞ (5 × to 8 × is 2 m (6.56 feet) to ∞)
Scene Mode	There may be difference in above settings.
Shutter system	Electronic shutter + Mechanical shutter
Burst recording	
Burst speed	2.3 pictures/second
Number of recordable pictures	Max. 5 pictures (Standard), max. 3 pictures (Fine)

Hi-speed burst	
Burst speed	Approx. 10 pictures/second (Speed priority) Approx. 6 pictures/second (Image priority)
Number of recordable pictures	Approx. 15 pictures (When using the built-in memory, immediately after formatting) Max. 100 pictures (When using a card, it may differ depending on the type of card and the recording conditions)
Shutter speed	60 to 1/2000 th [STARRY SKY] Mode: 15 seconds, 30 seconds, 60 seconds
Exposure (AE)	Program AE (P)/Aperture-priority AE (A)/ Shutter-priority AE (S)/Manual exposure (M) Exposure Compensation (1/3 EV Step, -2 EV to +2 EV)
Metering mode	Multiple/Center weighted/Spot
LCD monitor	2.7" TFT LCD (Approx. 230,400 dots) (field of view ratio about 100 %)
Flash	Flash range: (ISO AUTO) Approx. 60 cm (1.97 feet) to 5.3 m (17.4 feet) (Wide)
Microphone	Monaural
Speaker	Monaural
Recording media	Built-in Memory (Approx. 40 MB)/SD Memory Card/ SDHC Memory Card/SDXC Memory Card
Recording file format	
Still Picture	JPEG (based on Design rule for Camera File system, based on Exif 2.21 standard)/DPOF corresponding
Still pictures with audio	JPEG (based on Design rule for Camera File system, based on Exif 2.21 standard) + QuickTime
Motion pictures	QuickTime Motion JPEG (motion pictures with audio)

Interface	Digital: USB 2.0 (High Speed) Analogue video/audio: NTSC Composit, Audio line output (Monaural)
Terminal	AV OUT/DIGITAL: Dedicated jack (8 pin)
Dimensions	Approx. 103.3 mm (W) x 59.6 mm (H) x 32.6 mm (D) [4.07" (W) x 2.35" (H) x 1.28" (D)] (excluding the projection part)
Mass	With card and battery: Approx. 214 g (0.471 lb) Excluding card and battery: Approx. 191 g (0.421 lb)
Operating temperature	0 °C to 40 °C (32 °F to 104 °F)
Operating humidity	10 % to 80 %
Language select	[ENGLISH]/[ESPAÑOL]

Battery charger
(Panasonic DE-A65B): Information for your safety

Input	110 V to 240 V 50/60Hz, 0.2 A
Output	4.2 V --- 0.65 A (Battery charging)

Equipment mobility: Movable
Battery Pack (lithium-ion)
(Panasonic DMW-BCG10PP): Information for your safety

Voltage/capacity	3.6 V/895 mAh
-------------------------	---------------

Note:

*Above specification is for DMC-ZS5P. Some of the specification may differ depends on model suffix.

[1] Only for "EB/EF/EG/EP" models:

1). [Interface Digital:]

- Data form the PC can not be written to the camera using the USB connection cable.
- Motion pictures can be recorded continuously for up to 15minutes.
The maximum continuous recording time (up to 15minutes) is displayed on the screen.
- Analog video/audio:
NTSC -----(Only "P/PC/PU" models)
NTSC/PAL Composite (Switched by menu) -----(Except "P/PC/PU" models)

5 Location of Controls and Components

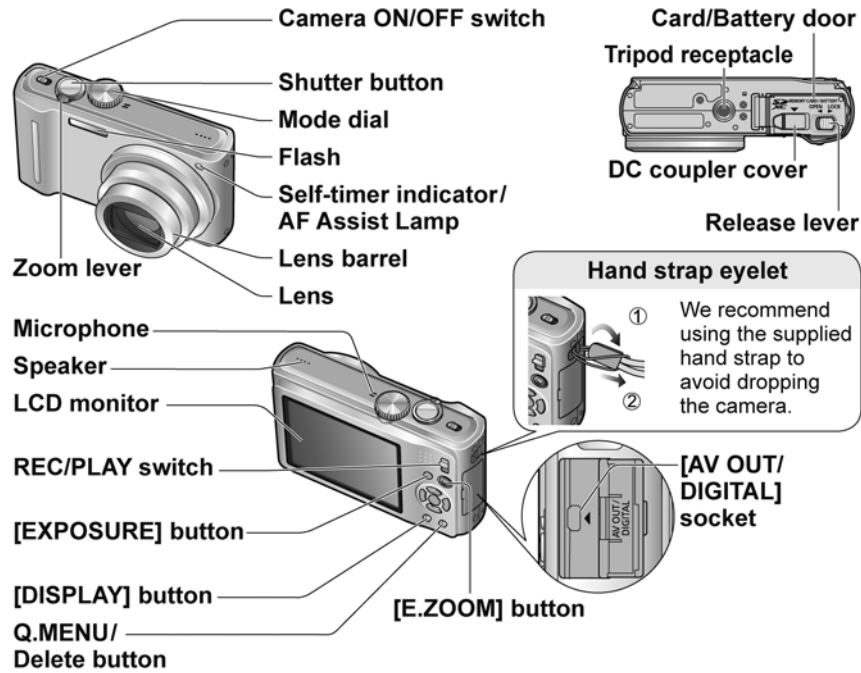

Cursor button

[MENU/SET] (menu display/set/finish)

Left cursor button (◀)
• Self-timer

Down cursor button (▼)
• Macro Mode
• AF Lock (AF Tracking)

Up cursor button (▲)
• Exposure Compensation
• Auto Bracket
• Multi Aspect
• White Balance fine adjustment

Right cursor button (▶)
• Flash

Mode dial

iA [INTELLIGENT AUTO] Mode	Take pictures with automatic settings.
P [PROGRAM AE] Mode	Record pictures with your own settings.
A [APERTURE-PRIORITY] Mode	Determine aperture, then record pictures.
S [SHUTTER-PRIORITY] Mode	Determine shutter speed, then record pictures.
M [MANUAL EXPOSURE] Mode	Determine aperture and shutter speed, then record pictures.
CUST [CUSTOM] Mode	Record pictures using pre-registered settings.
MS [MY SCENE MODE]	Take pictures in frequently-used Scene Modes.
SCN [SCENE MODE]	Take pictures according to scene.
[MOTION PICTURE] Mode	Take motion pictures.
[CLIPBOARD] Mode	Take pictures as memos.

About the Battery

- This unit has a function that can distinguish useable batteries. Exclusive batteries are supported by this function. (Conventional batteries not supported by this function cannot be used.)

It has been found that counterfeit battery packs which look very similar to the genuine product are made available to purchase in some markets. Some of these battery packs are not adequately protected with internal protection to meet the requirements of appropriate safety standards. There is a possibility that these battery packs may lead to fire or explosion. Please be advised that we are not liable for any accident or failure occurring as a result of use of a counterfeit battery pack. To ensure that safe products are used we would recommend that a genuine Panasonic battery pack is used.

6 Service Mode

6.1. Error Code Memory Function

1. General description

This unit is equipped with history of error code memory function, and can be memorized 16 error codes in sequence from the latest. When the error is occurred more than 16, the oldest error is overwritten in sequence.

The error code is not memorized when the power supply is shut down forcibly (i.e., when the unit is powered on by the battery, the battery is pulled out) The error code is memorized to FLASH ROM when the unit has just before powered off.

2. How to display

The error code can be displayed by ordering the following procedure:

• Preparation:

1. Attach the Battery or AC Adaptor with a DC coupler to the unit.
2. Set the mode dial to the PROGRAM AE mode.

Note:

*Since this unit has built-in memory, it can be performed without inserting SD memory card.

• Step 1. The temporary cancellation of "INITIAL SETTINGS":

Set the REC/PLAYBACK selector switch to "REC (Camera mark)".

While keep pressing "UP of Cursor button" and DISPLAY button simultaneously, turn the Power on.

• Step 2. Execute the error code display mode:

Press the "LEFT of Cursor button", MENU/SET button and DISPLAY button simultaneously.

The display is changed as shown below when the above buttons are pressed simultaneously.

Normal display → Error code display → Operation history display → Normal display →

Example of Error Code Display

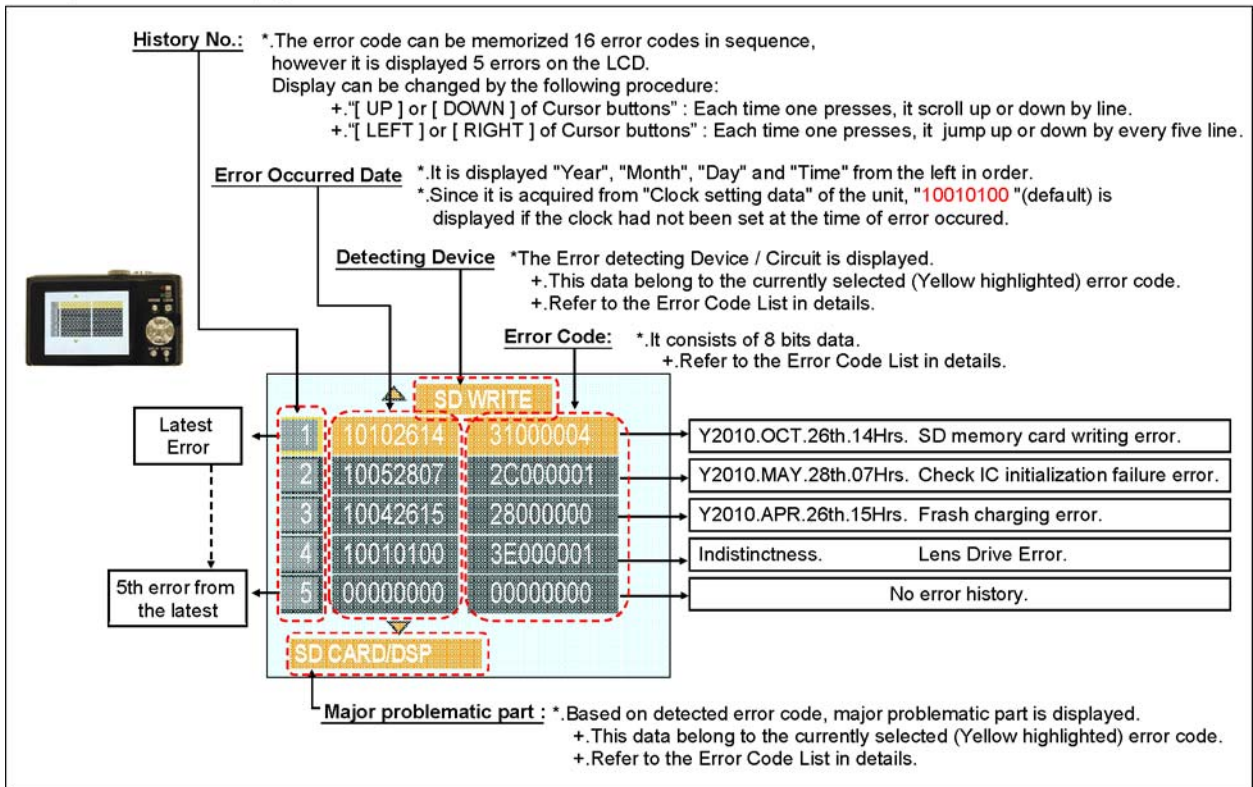

3. Error Code List

The error code consists of 8 bits data and it shows the following information.

Attribute	Main item	Sub item	Error code		Contents (Upper)	Error Indication		
			High 4bits	Low 4 bits	Check point (Lower)	Detecting device	Part/Circuit	
LENS	Lens drive	OIS	18*0	1000	PSD (X) error. Hall element (X axis) position detect error in OIS unit. OIS Unit	OIS X	LENSu NG	
				2000	PSD (Y) error. Hall element (Y axis) position detect error in OIS unit. OIS Unit	OIS Y		
			3000	GYRO (X) error. Gyro (IC7301) detect error on Main P.C.B. IC7301 (Gyro element) or IC6001 (VENUS 6)	GYRO X	GYRO NG		
				4000	GYRO (Y) error. Gyro (IC9701) detect error on Main P.C.B. IC9701 (Gyro element) or IC6001 (VENUS 6)		GYRO Y	
			5000	MREF error (Reference voltage error). IC9101 (LENS drive) or IC6001 (VENUS 6)	OIS REF	LENSSd/DSP NG		
				6000	Drive voltage (X) error. LENS Unit, LENS flex breaks, IC6001(VENUS 6) AD value error, etc.		OISX REF	LENSu/LENS FPC
			7000	Drive voltage (Y) error. LENS Unit, LENS flex breaks, IC6001(VENUS 6) AD value error, etc.	OISY REF			
			Zoom (C.B.)	0?10	Collapsible barrel Low detect error (Collapsible barrel encoder always detects Low.) Mechanical lock, FP9005-(26) signal line or IC6001 (VENUS 6)	ZOOM L	ZOOMm/ LENSu	
					0?20	Collapsible barrel High detect error (Collapsible barrel encoder always detects High.) Mechanical lock, FP9005-(26) signal line or IC6001 (VENUS 6)		ZOOM H
					0?30	Zoom motor sensor error. Mechanical lock, FP9005-(37), (40) signal line or IC6001 (VENUS 6)	ZOOM ENC	
						0?40		Zoom motor sensor error. (During monitor mode.) Mechanical lock, FP9005-(37), (40) signal line or IC6001 (VENUS 6)
					0?50	Zoom motor sensor error. (During monitor mode with slow speed.) Mechanical lock, FP9005-(37), (40) signal line or IC6001 (VENUS 6)		
		0?01				HP High detect error (Focus encoder always detects High, and not becomes Low) Mechanical lock, FP9005-(26) signal line or IC6001 (VENUS 6)	FOCUS L	LENS FPC/ DSP
		0?02	HP Low detect error (Focus encoder always detects Low, and not becomes High) Mechanical lock, FP9005-(26) signal line or IC6001 (VENUS 6)	FOCUS H				
		Lens	18*1	0000	Power ON time out error. Lens drive system	LENS DRV	LENSu	
				18*2	0000			Power OFF time out error. Lens drive system
		Adj.History	OIS	19*0	2000	OIS adj. Yaw direction amplitude error (small)	OIS ADJ	OIS ADJ
					3000	OIS adj. Pitch direction amplitude error (small)		
					4000	OIS adj. Yaw direction amplitude error (large)		
					5000	OIS adj. Pitch direction amplitude error (large)		
					6000	OIS adj. MREF error		
					7000	OIS adj. time out error		
					8000	OIS adj. Yaw direction off set error		
					9000	OIS adj. Pitch direction off set error		
	A000				OIS adj. Yaw direction gain error			
	B000				OIS adj. Pitch direction gain error			
	C000				OIS adj. Yaw direction position sensor error			

Attribute	Main item	Sub item	Error code		Contents (Upper)	Error Indication		
			High 4bits	Low 4 bits	Check point (Lower)	Detecting device	Part/Circuit	
HARD	VENUS A/D	Flash	28*0	D000	OIS adj. Pitch direction position sensor error			
				E000	OIS adj. other error			
	FLASH ROM (EEPROM Area)	FLASH ROM (EEPROM Area)	2B*0	0000	0000	Flash charging error. IC6001-(AC18) signal line or Flash charging circuit	STRB CHG	STRB PCB/FPC
					0001	EEPROM read error	FROM RE	FROM
				0003	IC6002 (FLASH ROM)	FROM WR	FROM	
				0004	EEPROM write error IC6002 (FLASH ROM)			
				0005	Firmware version up error Replace the firmware file in the SD memory card.	(No indication)	(No indication)	
				0008	SDRAM error			
	0009	SDRAM Mounting defective						
	SYSTEM	RTC	2C*0	0001	SYSTEM IC initialize failure error Communication between IC6001 (VENUS 6) and IC9101 (SYSTEM)	SYS INIT	MAIN PCB	
SOFT	CPU	Reset	30*0	0001 0007	NMI reset Non Mask-able Interrupt (30000001-30000007 are caused by factors)	NMI RST	MAIN PCB	
	Card	Card	31*0	0001	Card logic error SD memory card data line or IC6001 (VENUS 6)	SD CARD	SD CARD/DSP	
				0002	Card physical error SD memory card data line or IC6001 (VENUS 6)			
				0004	Write error SD memory card data line or IC6001 (VENUS 6)	SD WRITE		
				0005	Format error	INMEMORY		FROM
			39*0	0005	Format error	INMEMORY	FROM	
	CPU, ASIC hard	Stop	38*0	0001	0001	Camera task finish process time out. Communication between Lens system and IC6001 (VENUS 6)	LENS COM	LENSu/DSP
					0002	Camera task invalid code error. IC6001 (VENUS 6)	DSP	DSP
					0100	File time out error in recording motion image IC6001 (VENUS 6)		
					0200	File data cue send error in recording motion image IC6001 (VENUS 6)		
					0300	Single or burst recording brake time out.		
	Memory area	3A*0	0008	work area partitioning failure USB dynamic memory securing failure when connecting	(No indication)	(No indication)		
	Operation	Power on	3B*0	0000	FLASH ROM processing early period of camera during movement.	INIT	(No indication)	
	Zoom	Zoom	3C*0	0000	Imperfect zoom lens processing Zoom lens	ZOOM	ZOOMm/LENSu	
					35*0	0000 FFFF	Software error (0-7bit : command, 8-15bit : status)	DSP
			35*1	0000	Though record preprocessing is necessary, it is not called.	(No indication)	(No indication)	
			35*2	0000	Though record preprocessing is necessary, it is not completed.			

Important notice about "Error Code List"

1) About "*" indication:

The third digit from the left is different as follows.

+In case of 0 (example: 18 0 01000)

When the third digit from the left shows "0", this error occurred under the condition of INITIAL SETTINGS has been completed.
It means that this error is occurred basically at user side.

+In case of 8 (example: 18 8 01000)

When the third digit from the left shows "8", this error occurred under the condition of INITIAL SETTINGS has been released.
(Example; Factory assembling-line before unit shipment, Service mode etc.)
It means that this error is occurred at service side.

2) About "?" indication: ("18*0 0?01" to "18*0 0?50"):

The third digit from the right shows one of the hexadecimal ("0" to "F") character.

4. How to exit from Error Code display mode:

Simply, turn the power off. (Since Error code display mode is executed under the condition of temporary cancellation of "INITIAL SETTINGS", it wake up with normal condition when turn off the power.)

Note:

The error code can not be initialized.

6.2. ICS (Indication of additional Camera Settings when picture was taken) function

1. General description

This unit is equipped with ICS (ICS : Indication of additional Camera Settings when picture was taken) function by playing back the concerned picture on the LCD display.

(This function is achieved by utilizing "maker note" data stored in Exif data area of recorded picture file.)

To proceed failure diagnosis, use this ICS function together with "displaying the recorded picture with picture information" function.

Note:

- *.The ICS function operates with a picture which is only taken with the same model. (It may not be displayed when the picture was taken with other model.)
- *.Since Exif data is not available after the picture is edited by PC, the ICS function may not be activated.

2. How to display

The ICS data is displayed by ordering the following procedure:

• Preparation:

- 1.Attach the Battery or AC Adaptor with a DC coupler to the unit.
2. Set the mode dial to the PROGRAM AE mode.

• Step 1. The temporary cancellation of "INITIAL SETTINGS":

Set the REC/PLAYBACK selector switch to "REC (Camera mark)".

While keep pressing "UP of Cursor button" and DISPLAY button simultaneously, turn the Power on.

• Step 2. Execute the ICS display mode:

Set the REC/PLAYBACK selector switch to PLAYBACK.

Select the concerned picture by pressing the "LEFT and RIGHT of Cursor button".

Press the "LEFT of Cursor button", MENU/SET button and DISPLAY button simultaneously.

Press the DISPLAY button, 3 times.

The display condition is changed as shown below when the DISPLAY button is pressed.

Code display → Code + Picture display (1) → Code + Picture display (2) → ICS display →

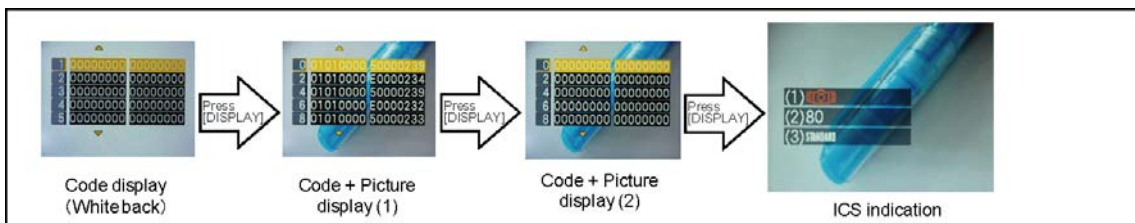

3. How to read

(1). Jitter alert was displayed or not:
 This part shows that the "Jitter alert" mark was displayed or not when the picture has just before been taken.
 + With "Jitter alert" mark : The "Jitter alert" mark was displayed.
 + Without "Jitter alert" mark: The "Jitter alert" mark was not displayed.
 [About "Jitter alert" mark]
 Due to lacking the enough light amount etc, shooting condition prone to make a "hand jitter", the "Jitter alert" mark is displayed.
 [Reference Guide]
 (Applicable settings : Normal picture mode, ISO100, WIDE edge, Flash OFF)
 + The "Jitter alert" mark is displayed when the shutter speed is 1/15th and below.

(2). ISO Sensitivity Setting condition:
 This part shows that the "ISO Sensitivity" setting condition when the picture had been taken.
 (Note: The [i ISO] is displayed when the "Intelligent ISO" was selected.)
 For instance, when the recorded picture information shows [ISO80], it can be confirmed the ISO setting condition : [AUTO], [INTELLIGENT ISO] or [ISO 80](Fixed: set by user).
 [Point for Confirmation]
 *The symptom is "Picture with "hand jitter". Subject is not clearly stopped." in darker scene, does the picture was taken with lower ISO setting mode?
 *The symptom is "Noisy picture. Rough picture image" in brighter scene, does the picture was taken with higher ISO setting mode?

(3). Color mode Setting condition:
 This part shows that the "Color mode" setting condition when the picture had been taken.
 [Point for Confirmation]
 *The symptom is "Color is strange. The picture is bluish (Yellowish) ", does the picture was taken with [SEPIA]/[COOL]/ [WARM] settings?
 NOTE: As for the symptom related with the color, confirm the picture information which is displayed in normal playback screen as well.
 (In normal playback screen, the setting condition of "White balance" and "WB Adjustment "can be confirmed.)

[ICS display (Sample)]

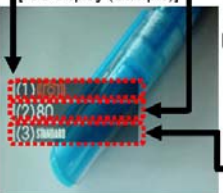

(1). Jitter alert mark : [Indicated]
 (2). ISO sens. setting : ISO80 (Fixed)
 (3). Color mode setting: Standard

Normal playback screen
 (Recorded picture with information)



*In playback mode, the picture information is displayed when pressing the [DISPLAY] button. (It can be confirmed at user as well.)
 *Use this indication together with ICS function.

[Reference Guide : Settings "When taking picture"]

<ISO SENSITIVITY>
 *This allows the sensitivity to light (ISO sensitivity) to be set. Setting to a higher figure enables pictures to be taken even in dark places without the resulting pictures coming out dark.
 *In this unit, it can be set one of the [AUTO], [80], [100], [200], [400], [800] and [1600] in "Normal shooting" mode.
 (The ISO sensitivity setting is not available when the [INTELLIGENT ISO] is being used.)
 *When setting to [AUTO], the ISO sensitivity is automatically adjusted to a maximum of [ISO400] according to the brightness.
 (It can be adjusted to a maximum of [ISO1000] when using the flash.)
 *To avoid picture noise, we recommend that you either reduce the ISO sensitivity level or set [COLOR MODE] to [NATURAL], and then take pictures.

ISO sensitivity	80	1600
Recording location (recommended)	When it is light (outdoors)	When it is dark
Shutter speed	Slow	Fast
Noise	Less	Increased

<COLOR MODE>
 *Using these modes, the pictures can be made sharper or softer, the colors of the pictures can be turned into sepia colors or other color effects can be achieved.
 *In this unit, it can be set one of the following effects in "Normal shooting" mode.

[STANDARD] : This is the standard setting.	[BW] : The picture becomes black and white.
[NATURAL] : The picture becomes softer.	[SEPIA] : The picture becomes sepia.
[VIVID] : The picture becomes sharper.	[COOL] : The picture becomes bluish.
	[WARM] : The picture becomes reddish.

NOTE: You cannot set [NATURAL], [VIVID], [COOL] or [WARM] in Intelligent auto mode.
 *When you take pictures in dark places, noise may become visible. To avoid noise, we recommend setting to [NATURAL].



4. How to exit

Simply, turn the power off. (Since ICS function is executed under the condition of temporary cancellation of "INITIAL SETTINGS", it wake up with normal condition when turn off the power.)

7 Service Fixture & Tools

7.1. Service Fixture and Tools

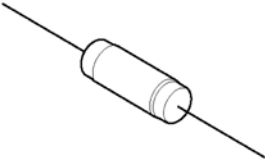
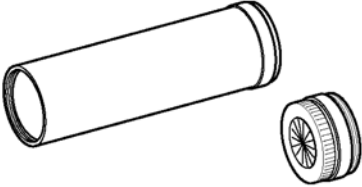
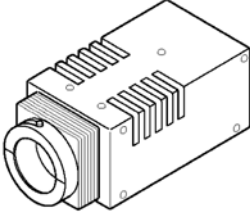
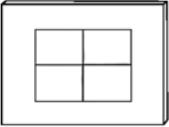
The following Service Fixture and tools are used for checking and servicing this unit.

Resistor for Discharging ERG5SJ102	Infinity Lens (Built-in Focus Chart) VFK1164TCM02	LIGHT BOX VFK1164TDVLB
 <p>An equivalent type of Resistor may be used.</p>	 <p>※ RFKZ0422 can be used.</p>	 <p>※ with DC Cable</p>
TR Chart RFKZ0443	Lens Cleaning Kit (BK) VFK1900BK	Grease (for Lens) (for focus motor) RFKZ0472
	 <p>* Only supplied as 10 set/box.</p>	

7.2. When Replacing the Main P.C.B.

After replacing the MAIN P.C.B., be sure to achieve adjustment.

The Maintenance software (DIAS) is available at “software download” on the “Support Information from NWBG/VDBG-AVC” website in “TSN system”.

7.3. Service Position

This Service Position is used for checking and replacing parts. Use the following Extension cables for servicing.

No.	Parts No.	Connection	Form
1	RFKZ0477	FP9003 (MAIN) - CCD UNIT	45PIN 0.3 FFC
2	RFKZ0477	FP9005 (MAIN) - LENS UNIT	45PIN 0.3 FFC
3	VFK1541	PP9802 (MAIN) - PS9901 (TOP OPERATION P.C.B.)	40PIN B to B
4	VFK1906	PP8001 (FLASH P.C.B.) - PS9903 (TOP OPERATION P.C.B.)	20PIN B to B

7.3.1. Extension Cable Connections

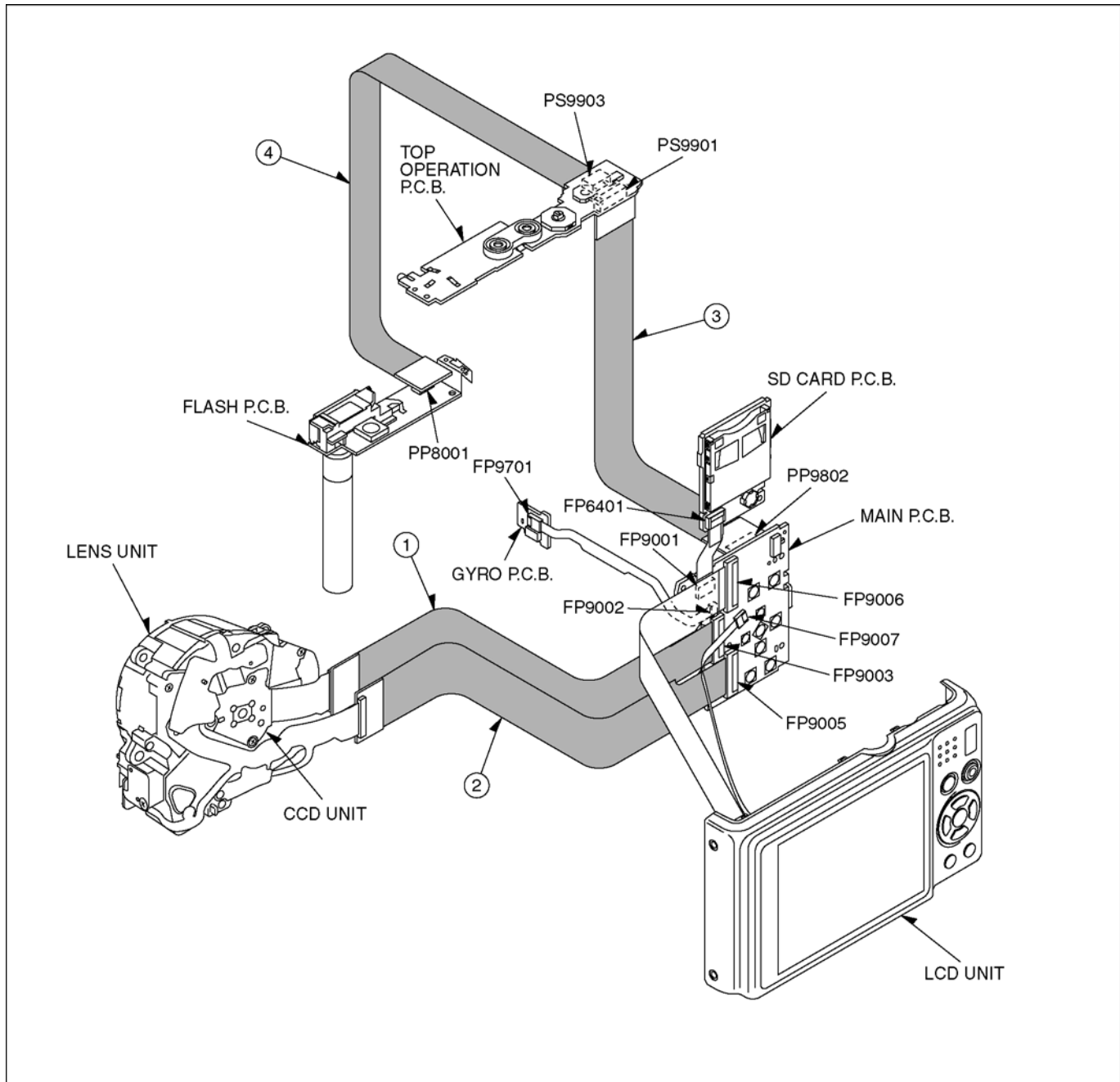

CAUTION-1. (When servicing FLASH P.C.B.)

1. Be sure to discharge the capacitor on FLASH P.C.B.
Refer to "HOW TO DISCHARGE THE CAPACITOR ON FLASH P.C.B.". The capacitor voltage is not lowered soon even if the AC Cord is unplugged or the battery is removed.
2. Be careful of the high voltage circuit on FLASH P.C.B.
3. DO NOT allow other parts to touch the high voltage circuit on FLASH P.C.B.

8 Disassembly and Assembly Instructions

8.1. Disassembly Flow Chart

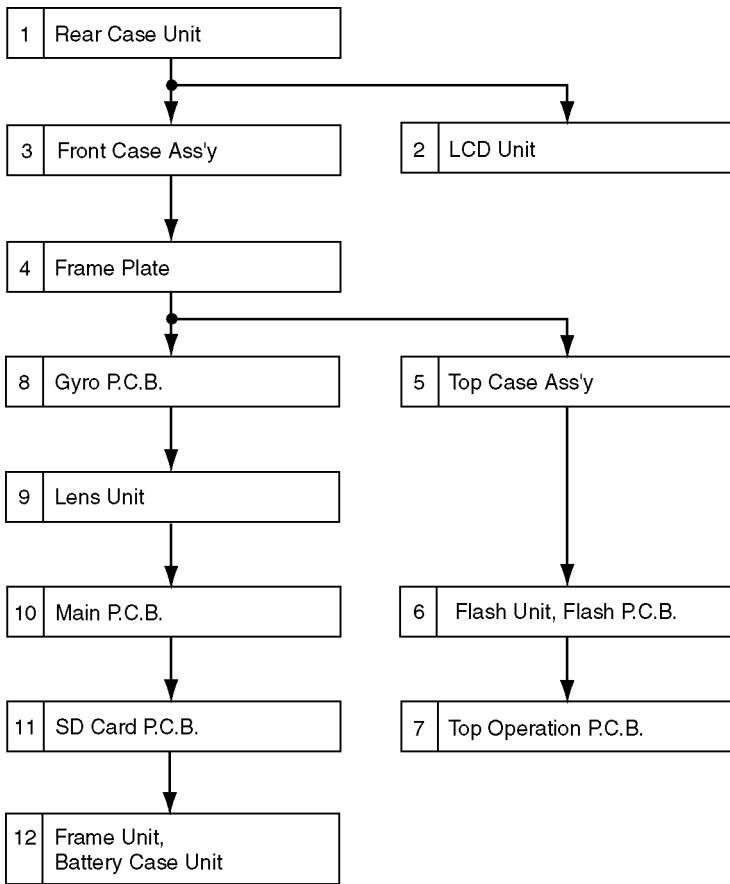

8.2. P.C.B. Location

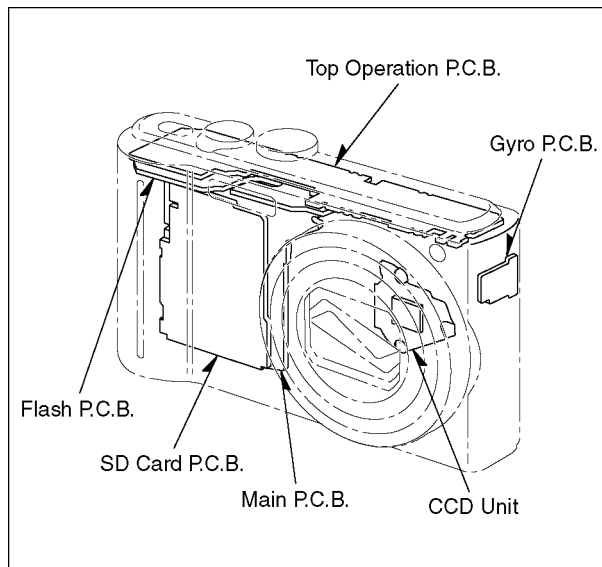

8.3. Disassembly Procedure

No.	Item	Fig.	Removal
1	Rear Case Unit	Fig.D1	SD Card Battery 6 Screws (A)
		Fig.D2	FP9006 (Flex) FP9007 (Flex) Rear Case Unit
2	LCD Unit	Fig.D3	5 Locking tabs LCD Unit
3	Front Case Ass'y	Fig.D4	5 Screws (B) Front Case Ass'y
4	Frame Plate	Fig.D5	3 Screws (C) Frame Plate
5	Top Case Ass'y	Fig.D6	3 Locking tabs PS9901 (Connector) PS9903 (Connector) Top Case Ass'y
6	Flash Unit, Flash P.C.B.	Fig.D7	2 Locking tabs Flash Unit Flash P.C.B.
7	Top Operation P.C.B.	Fig.D8	2 Locking tabs Flash Spacer 2 Locking tabs AF Panel Light 2 Screws (D) 6 Locking tabs Top Operation P.C.B.
8	Gyro P.C.B.	Fig.D9	FP9002 (Flex) Gyro P.C.B.
9	Lens Unit	Fig.D10	FP9003 (Flex) FP9005 (Flex) Tripod 2 Locking tabs 3 Screws (E) Lens Unit
10	Main P.C.B.	Fig.D11	1 Locking tab Slide Knob 2 Screws (F) FP9001 (Flex) 2 Locking tabs Main P.C.B.
11	SD Card P.C.B.	Fig.D12	1 Screw (G) 2 Locking tabs PCB Spacer SD Card P.C.B.
12	Frame Unit, Battery Case Unit	Fig.D13	Earth Plate 9 Locking tabs Battery Frame Unit Battery Case Unit

8.3.1. Removal of the Rear Case Unit

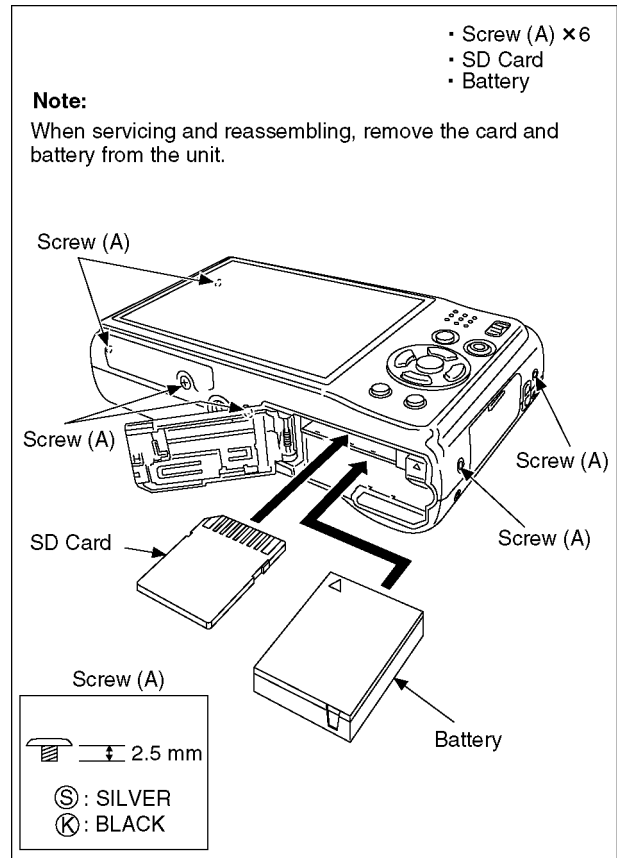

Fig. D1

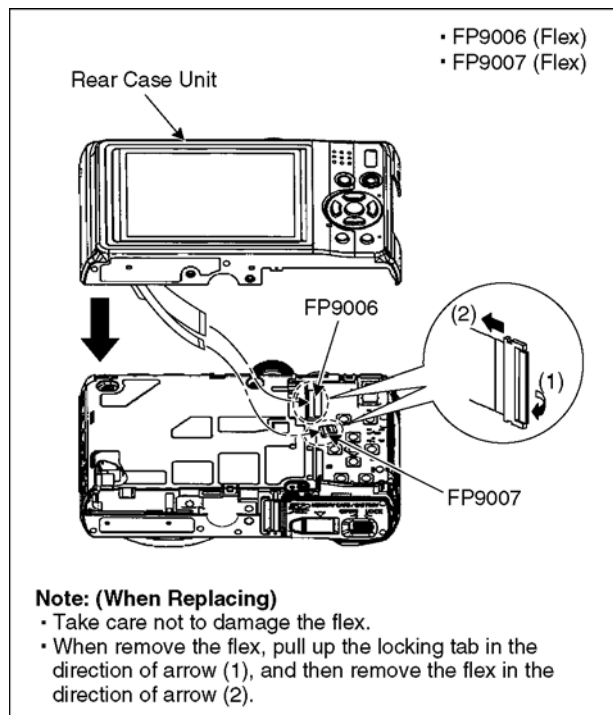

Fig. D2

8.3.2. Removal of the LCD Unit

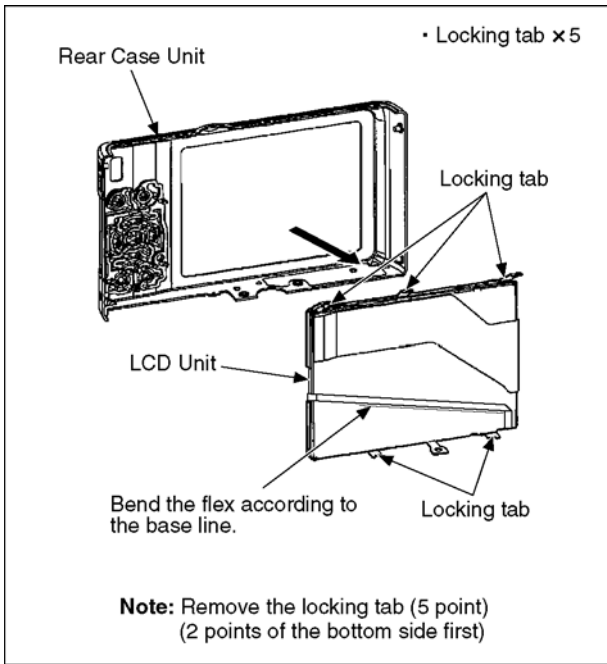

Fig. D3

8.3.3. Removal of the Front Case Ass'y

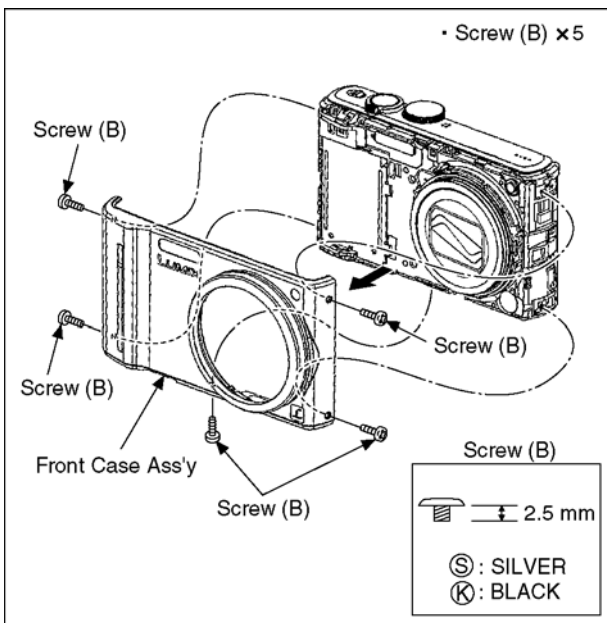

Fig. D4

8.3.4. Removal of the Frame Plate

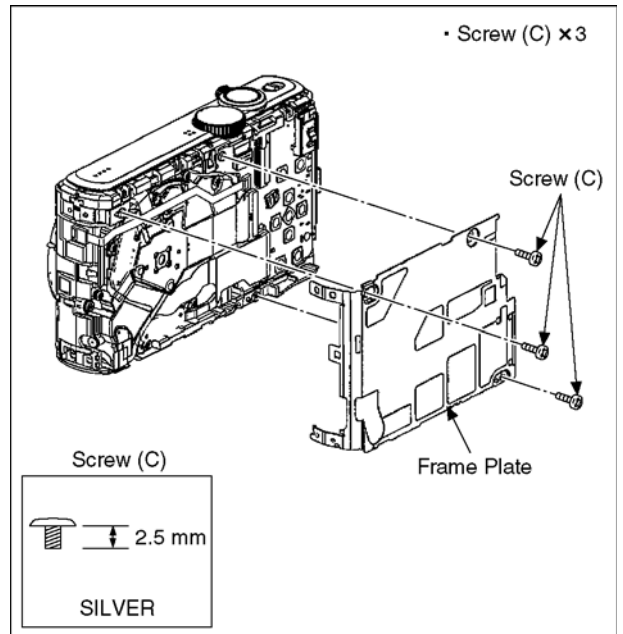

Fig. D5

8.3.5. Removal of the Top Case Ass'y

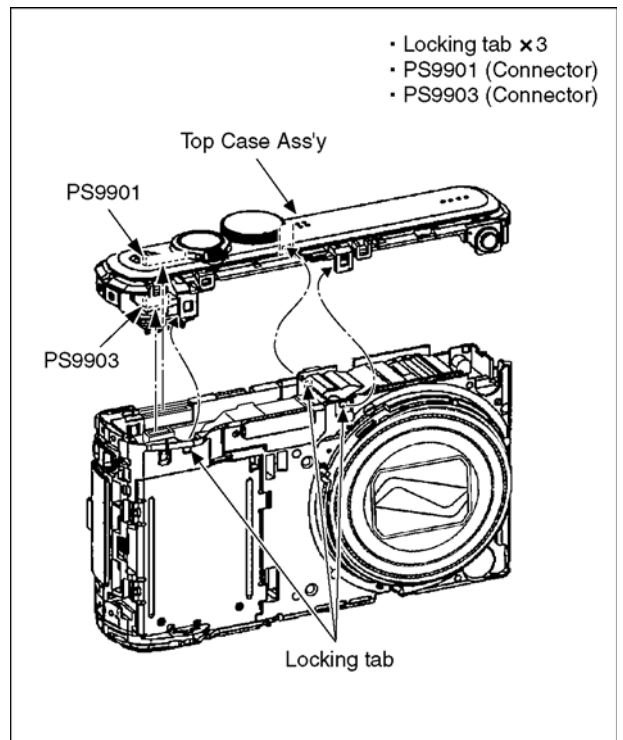

Fig. D6

8.3.6. Removal of the Flash Unit, Flash P.C.B.

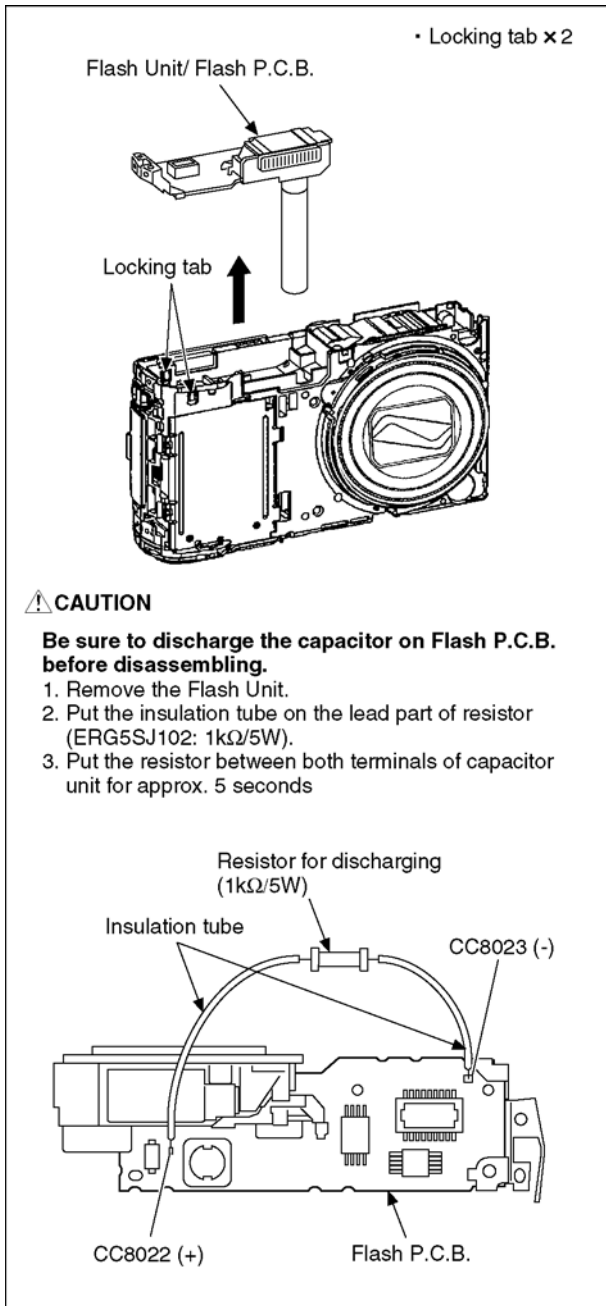

Fig. D7

8.3.7. Removal of the Top Operation P.C.B.

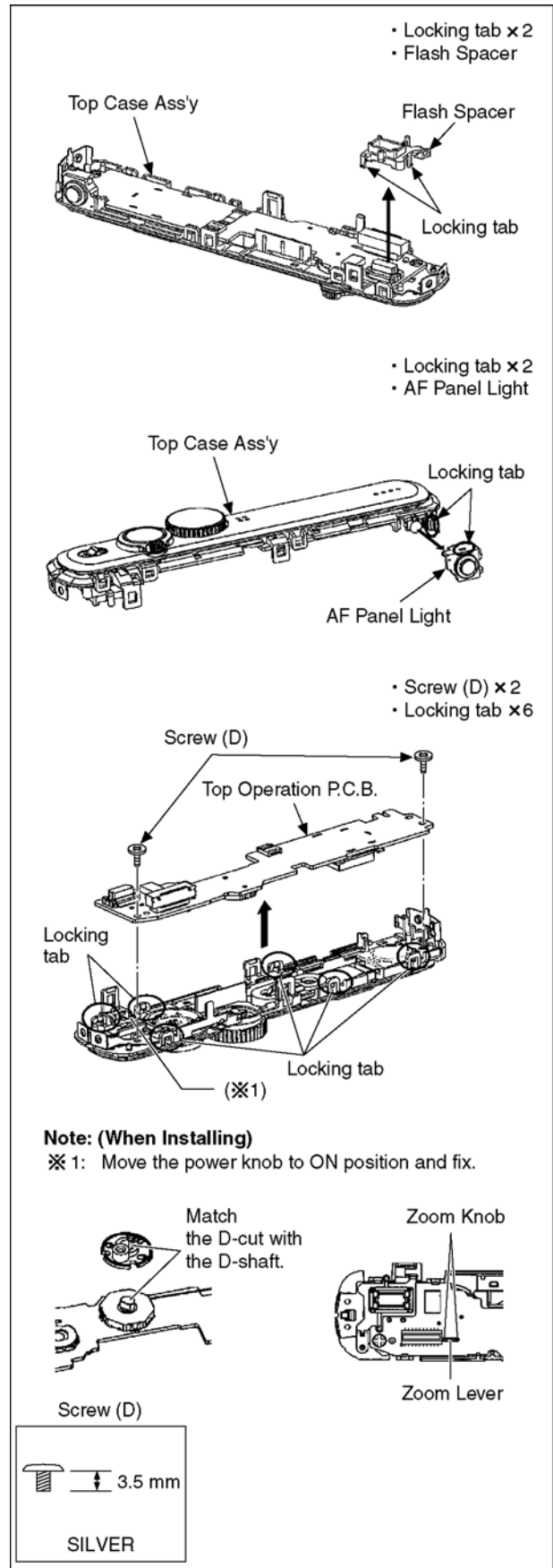

Fig. D8

8.3.8. Removal of the Gyro P.C.B.

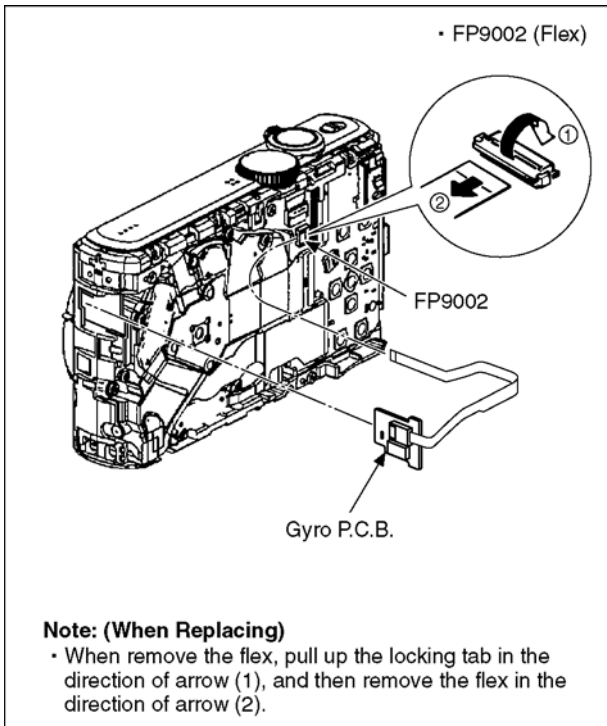

Fig. D9

8.3.9. Removal of the Lens Unit

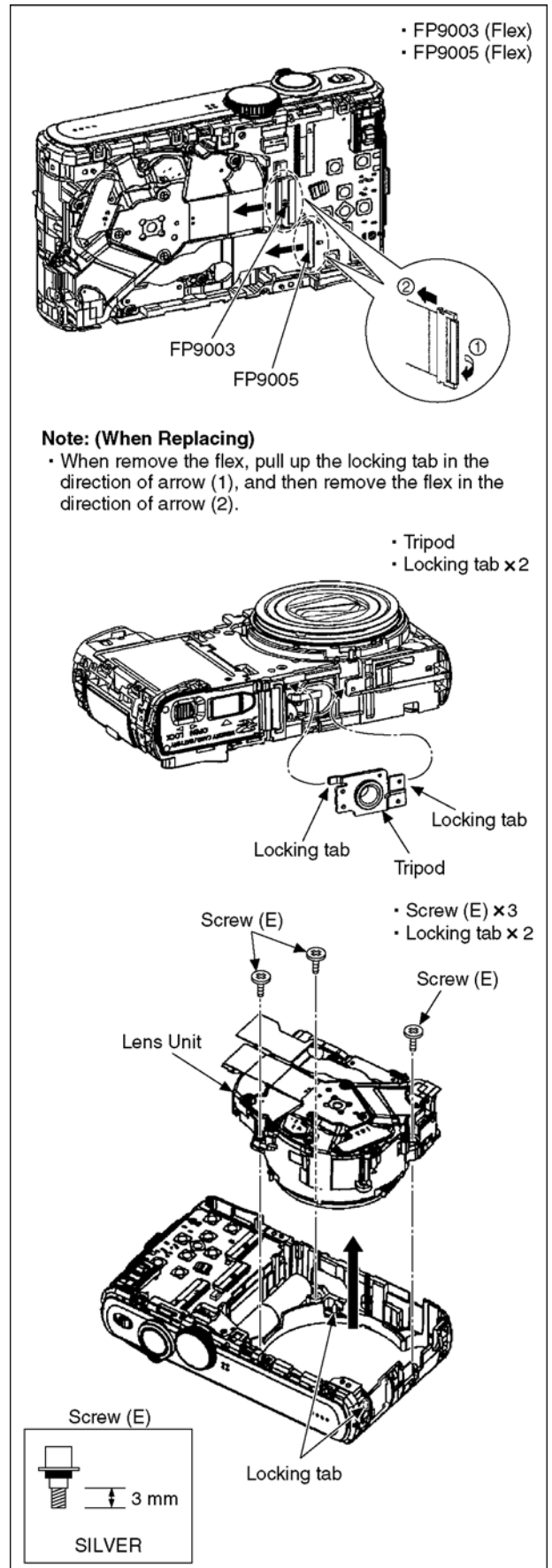

Fig. D10

8.3.10. Removal of the Main P.C.B.

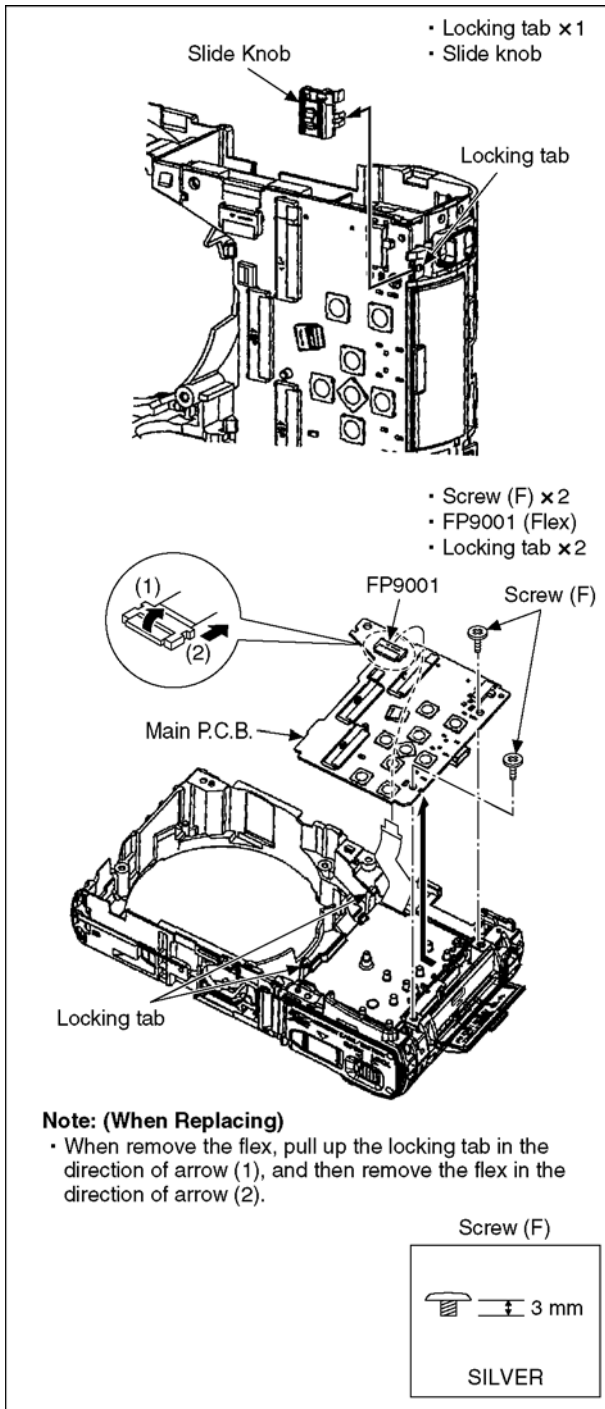

Fig. D11

8.3.11. Removal of the SD Card P.C.B.

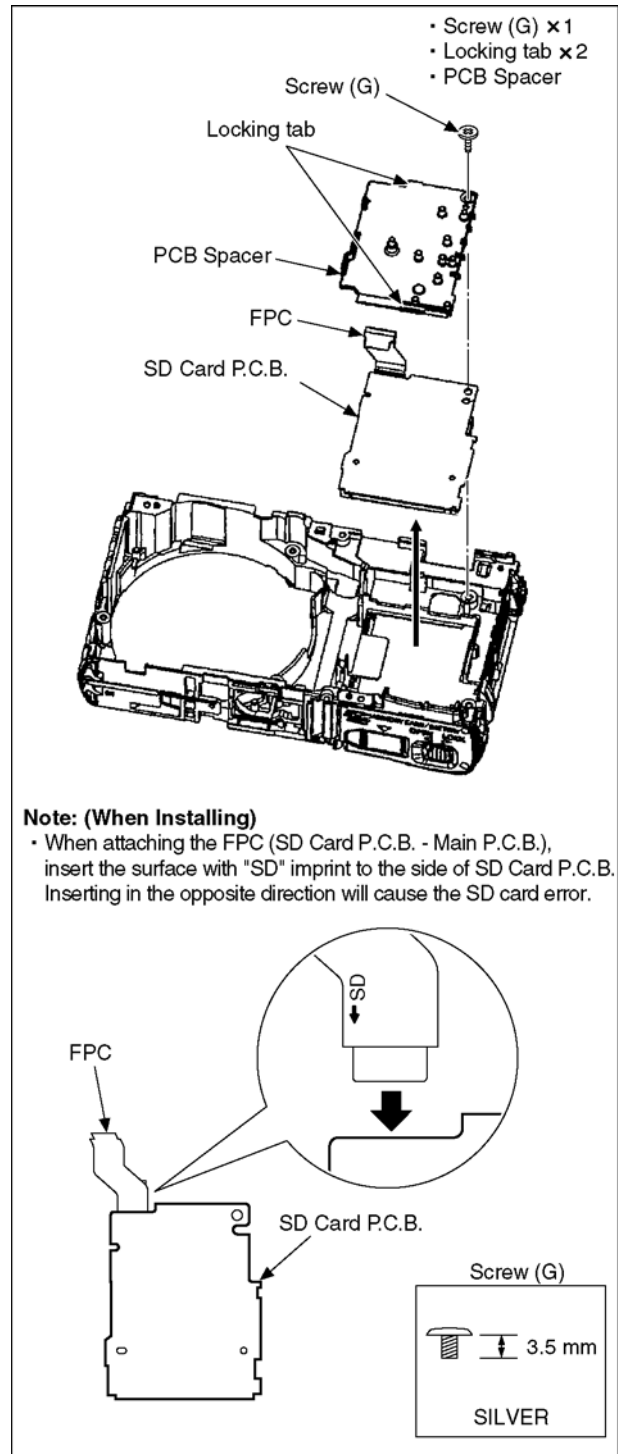

Fig. D12

8.3.12. Removal of the Battery Case Unit, Frame Unit

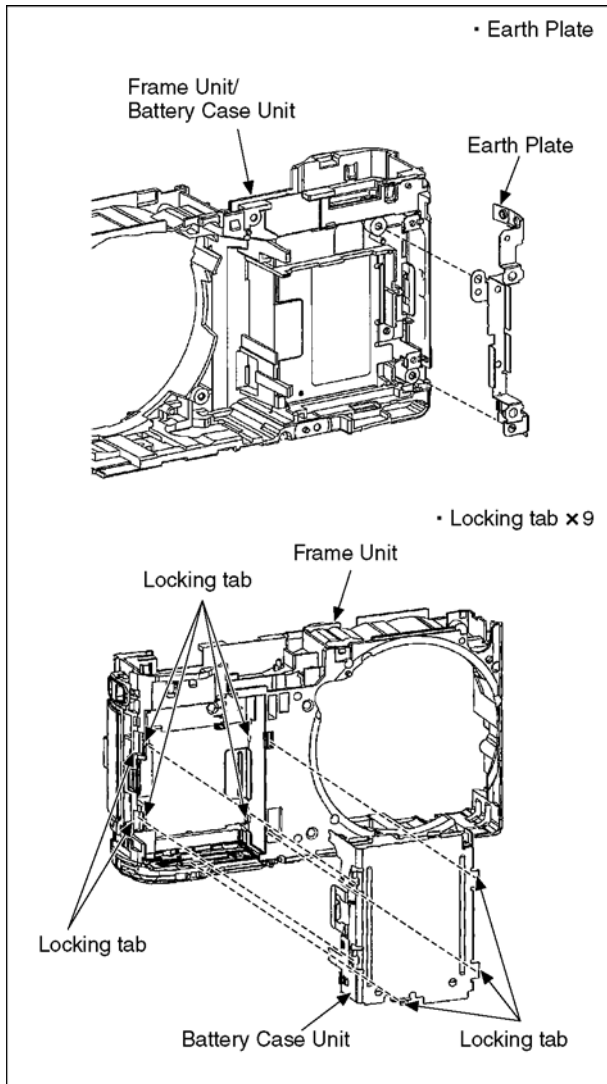

Fig. D13

Note: (When Assembling)

Be sure to confirm the following points when assembling.

- The Screw is tightened enough.
- Assembling conditions are fine. (No distortion, no illegal-space.)
- No dust and/or dirt on every Lens surfaces.
- LCD image is fine. (No dust and dirt on it, and no gradient images.)

8.4. Lens Disassembly Procedure

Precaution:

1. Do not remove the CCD when disassembling or re-assembling the lens in order to maintain it clean.
When remove it, refer to item "8.6".
2. Keep dust or dirt away from the lens.
3. To remove dirt or dust from the lens, blow with dry air.
4. Do not touch the lens surface.
5. Use lens cleaning KIT (BK)(VFK1900BK).
6. Apply grease (RFKZ0472) as shown on "THE APPLICATION OF GREASE METHOD" in the figure.
7. Apply a light coat of grease using an object similar to a toothpick.
8. The fixed frame, penetration cam, drive frame and two-sided cam should be replaced as a unit.

8.4.1. Removal of the Zoom Motor Unit and Master Flange Unit

1. Remove the libs (5 points).
2. Unscrew the 7 screws (A).
3. Unscrew the 1 screw (B).
4. Remove the zoom motor unit.
5. Remove the master flange unit.

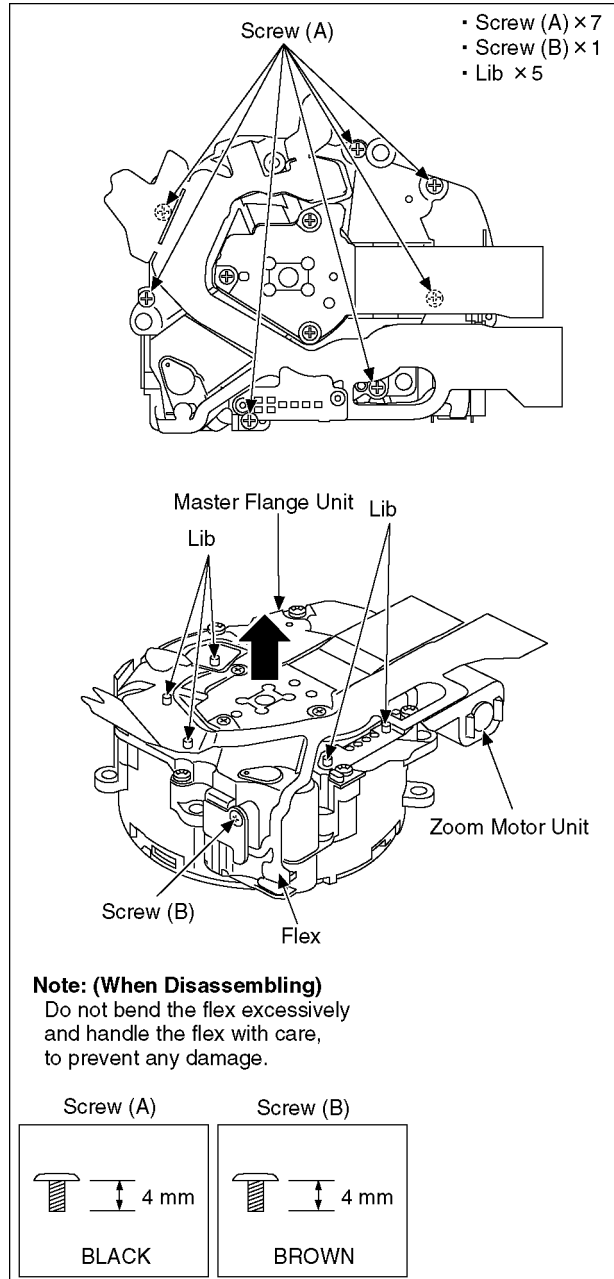

8.4.2. Removal of the Direct Frame, Both Side Cam, 1st Lens Frame/2nd Lens Frame/3rd Lens Frame, Penetration Cam and Drive Frame

- While keep rotating the Drive gear to the indicated by arrow (1), push the penetration cam to the indicated by arrow (2) from front, and then remove the unit of direct frame, both side cam, 1st lens frame/2nd lens frame/3rd lens frame, penetration cam and drive frame from the fixed frame unit.

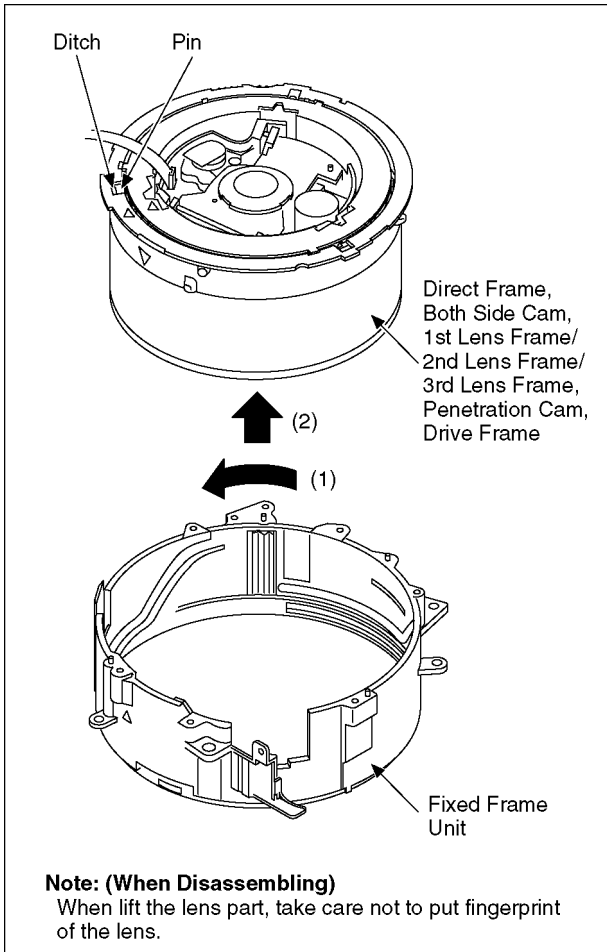

IMPORTANT NOTICE:

To maintain primary performance, the fixed frame, penetration cam, driving frame and two-sided cam donot replace individually only as a single item. Make sure to use the replacement part "Fixed cam frame (1)" as a unit.

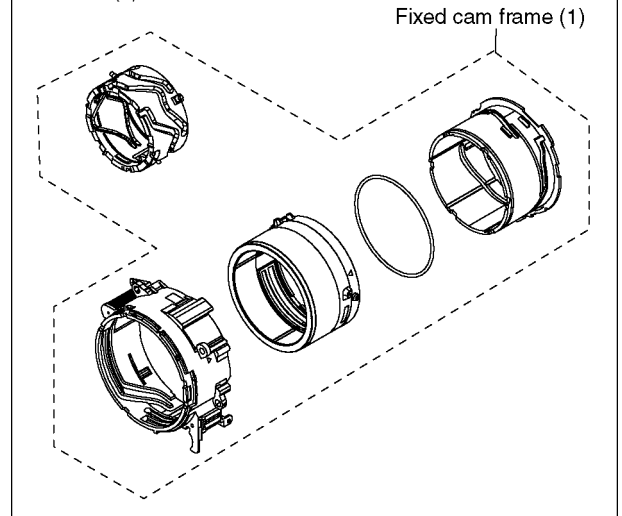

8.4.3. Removal of the Direct Frame, Both Side Cam and 1st Lens Frame/2nd Lens Frame/3rd Lens Frame

1. Turn the drive frame, and then Align the groove of drive frame and pin of 1st lens frame.

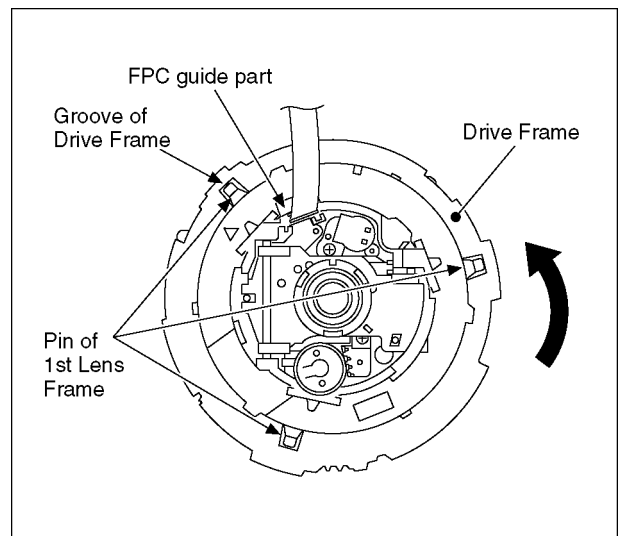

2. Push the 1st lens frame to the indicated by arrow from lens side, and then remove the unit of direct frame, both side cam and 1st lens frame/2nd lens frame/3rd lens frame from the penetration cam and drive frame.

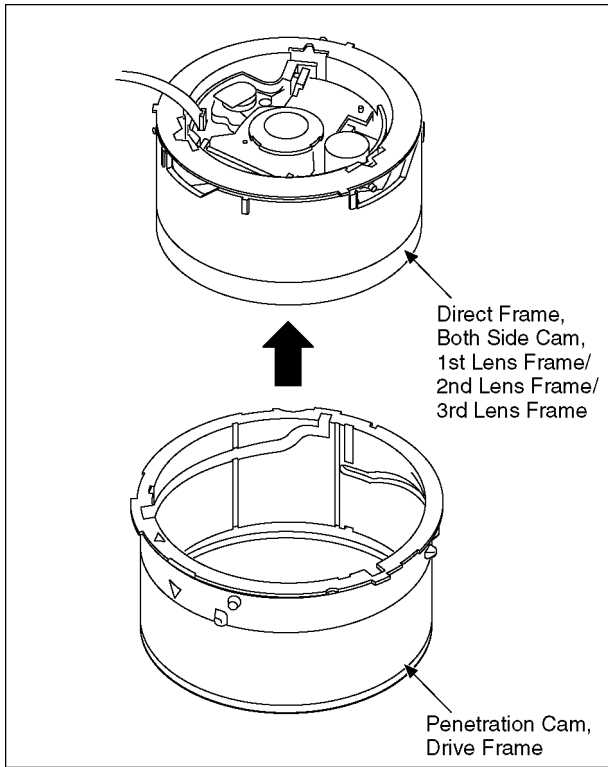

8.4.4. Removal of the Direct Frame, Both Side Cam and 2nd Lens Frame/3rd Lens Frame

- Turn to the indicated by arrow(1) while picking the pin, and then remove the unit of direct frame, both side cam and 2nd lens frame/3rd lens frame from the 1st lens frame.

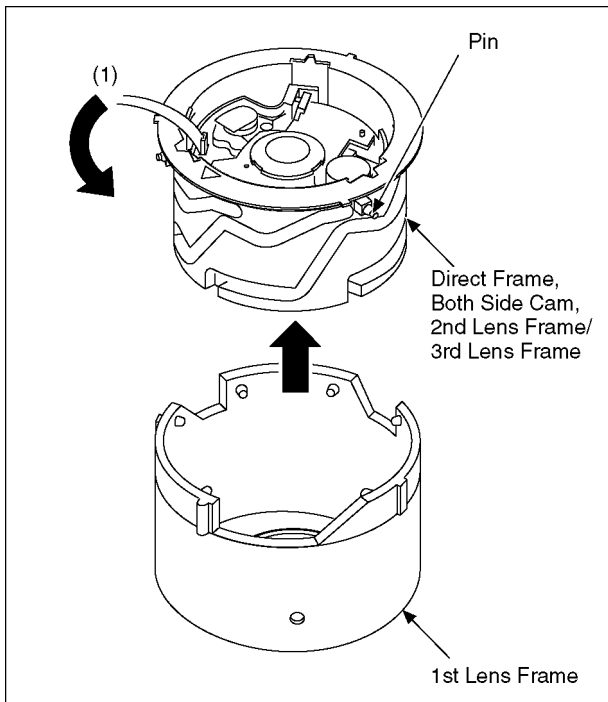

8.4.5. Removal of the 3rd Lens Frame and 2nd Lens Frame

1. Turn the direct frame, and then Align the groove of direct frame and groove of both side cam.
2. Remove the 3rd lens frame and 2nd lens frame from the direct frame, both side cam.

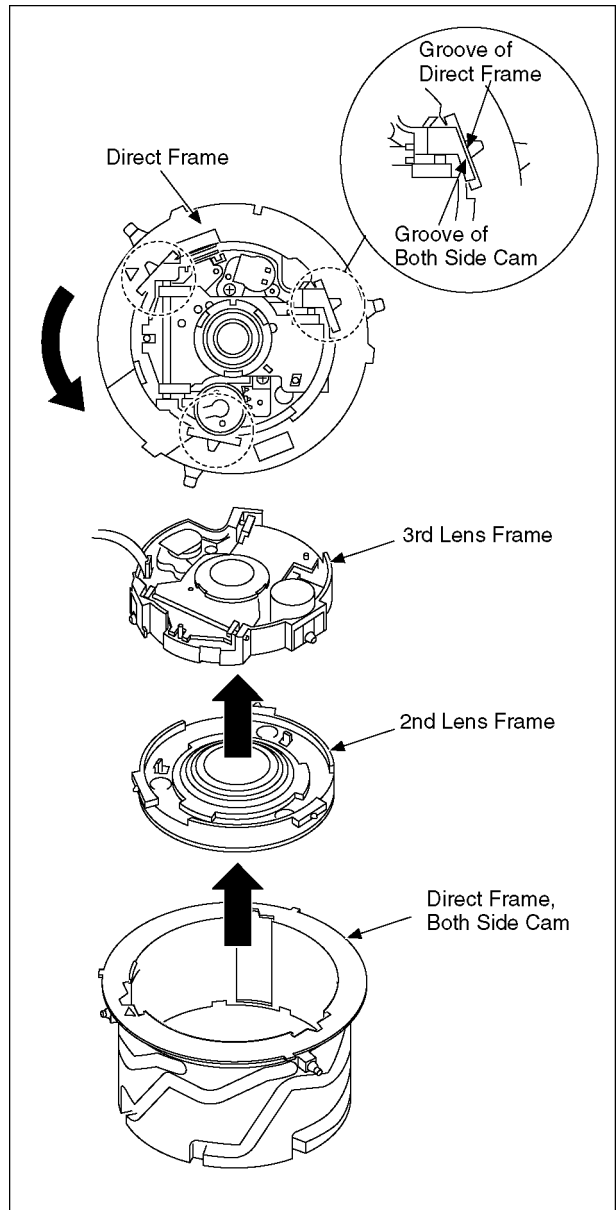

8.4.6. Removal of the Direct Frame

Pull the direct frame to the indicated by arrow (1), and then turn the direct frame in the indicated by arrow (2).

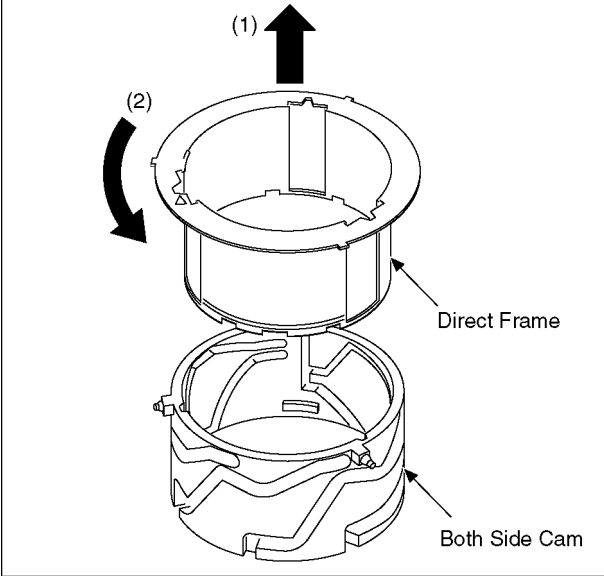

8.5. Assembly Procedure for Lens

8.5.1. Phase alignment of the Penetration Cam and Drive Frame

• Align the Δ mark, and then install the drive frame to penetration cam.

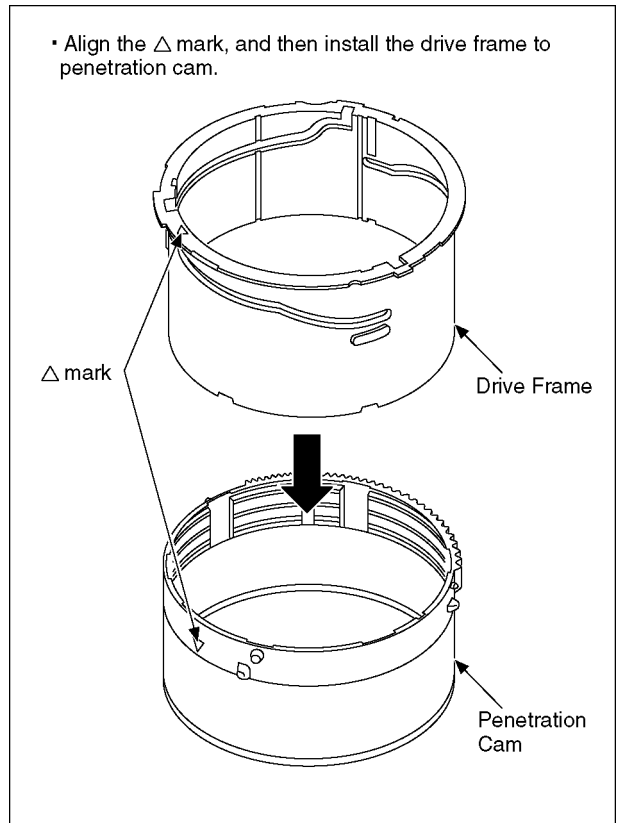

• Rotate the driving frame to the left direction and match Δ mark with ditches (3 locations).

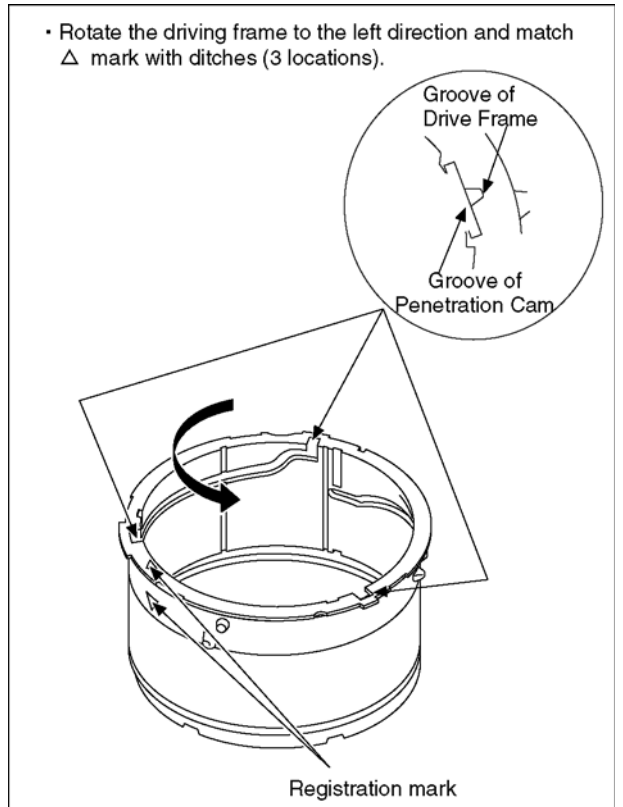

8.5.2. Phase alignment of the Direct Frame and Both Side Cam

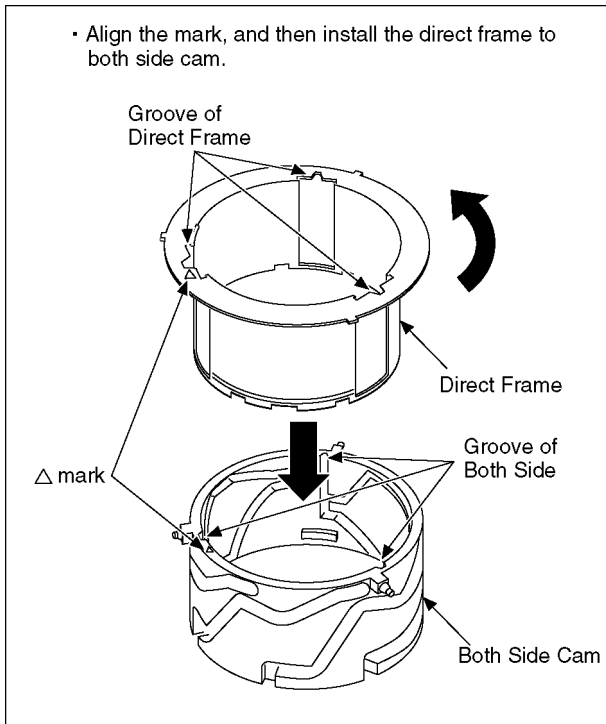

8.5.3. Assembly for the 2nd Lens Frame and 3rd Lens Frame

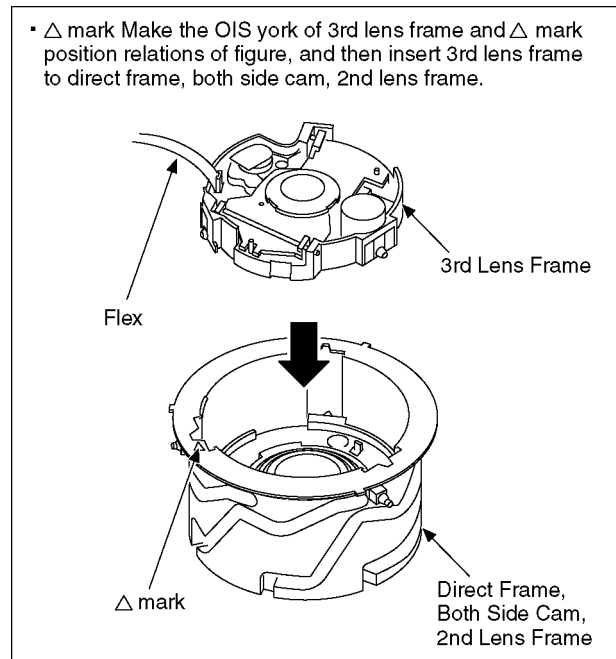
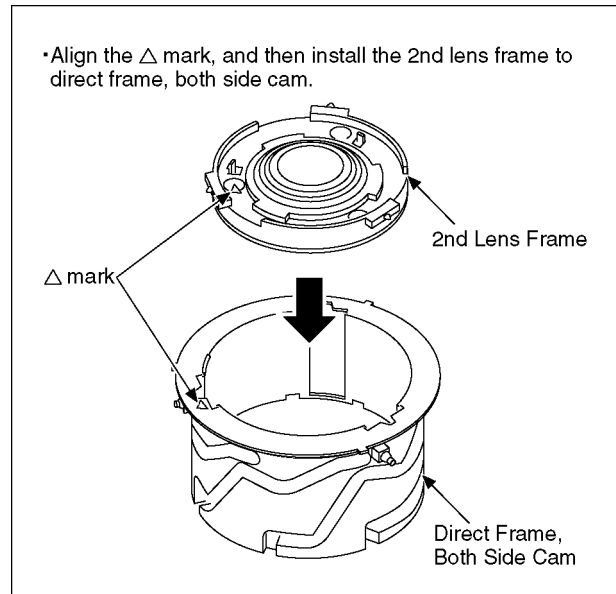

8.5.4. Assembly for the Direct Frame, Both Side Cam and 2nd Lens Frame/3rd Lens Frame

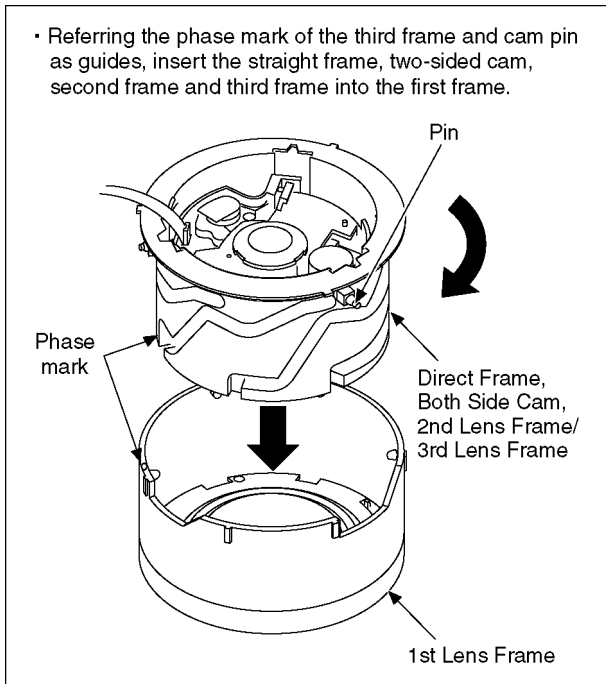

8.5.5. Assembly for the Direct Frame, Both Side Cam and 1st Lens Frame/ 2nd Lens Frame/ 3rd Lens Frame

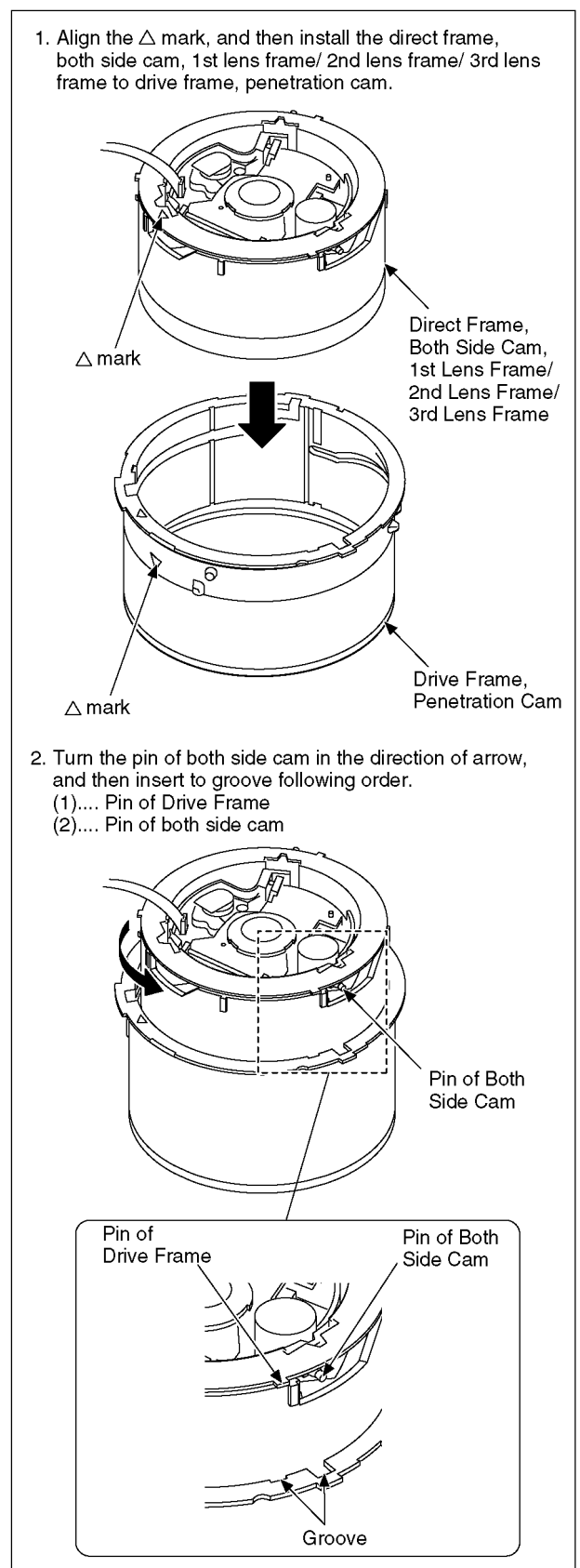

8.5.6. Assembly for the Direct Frame, Both Side Cam and 1st Lens Frame/ 2nd Lens Frame/3rd Lens Frame, Penetration Cam and Drive Frame

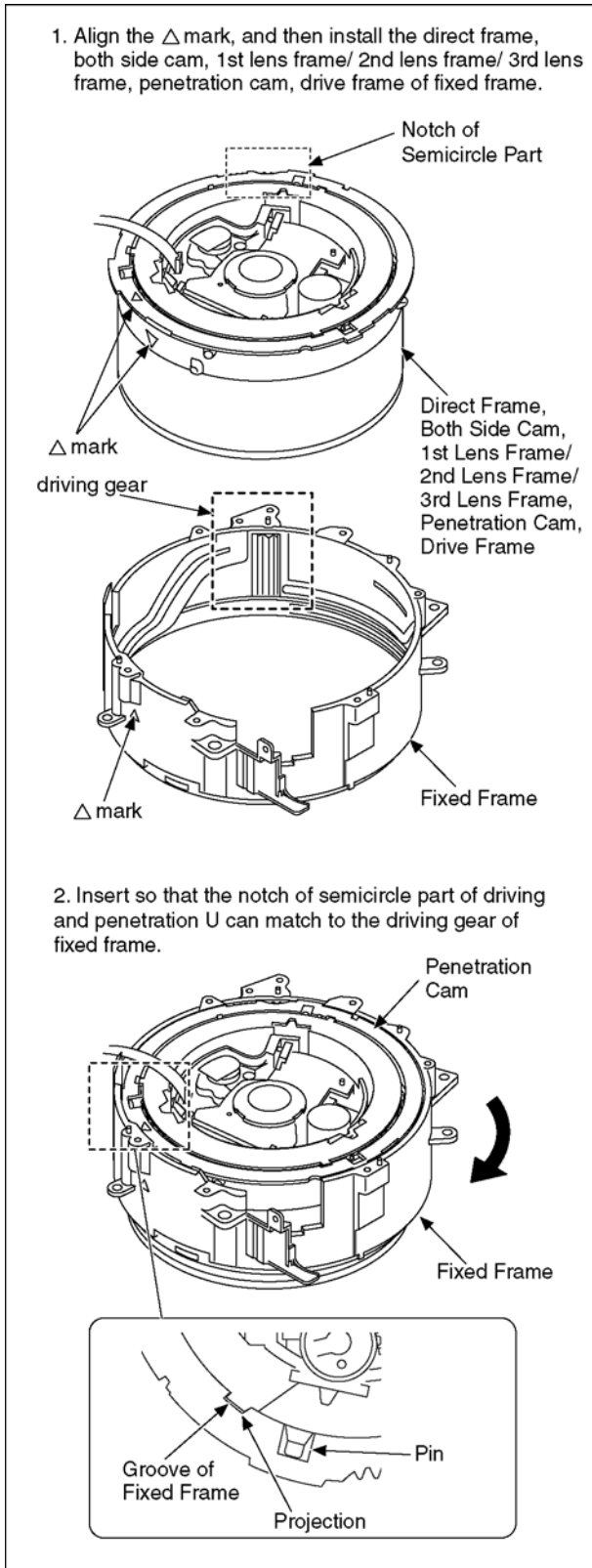

8.5.7. Assembly for the Zoom Motor Unit and Master Flange Unit

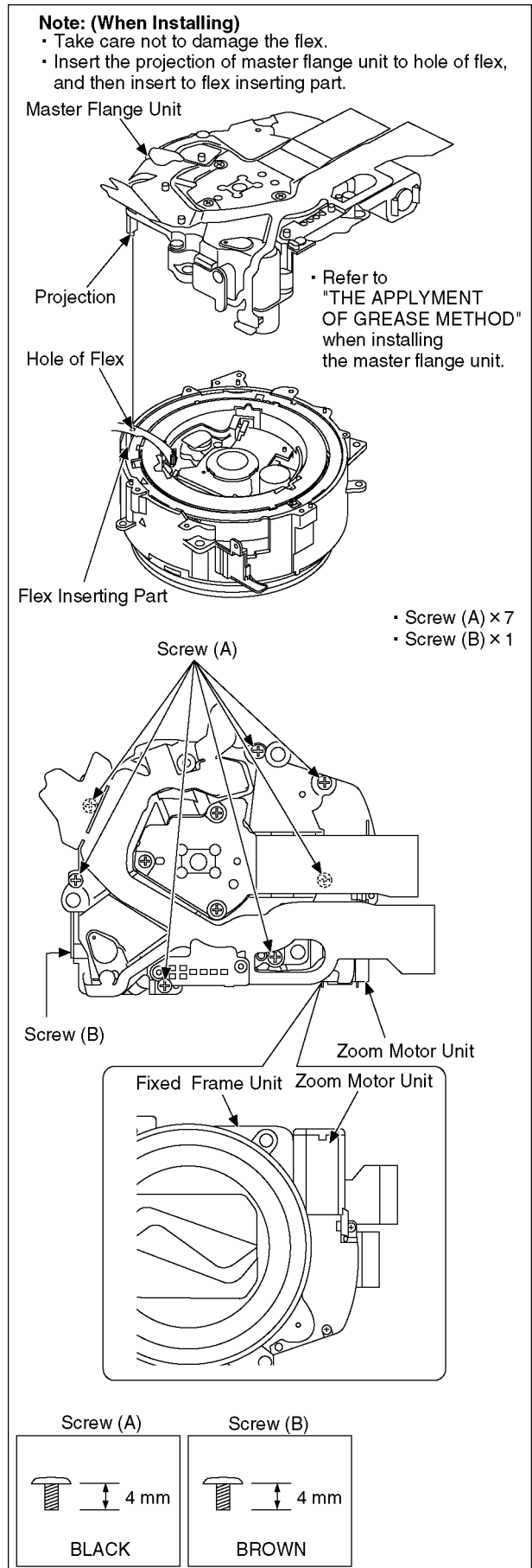

8.6. Removal of the CCD Unit

To prevent the CCD unit from catching the dust and dirt, do not remove the CCD unit except for replacing.

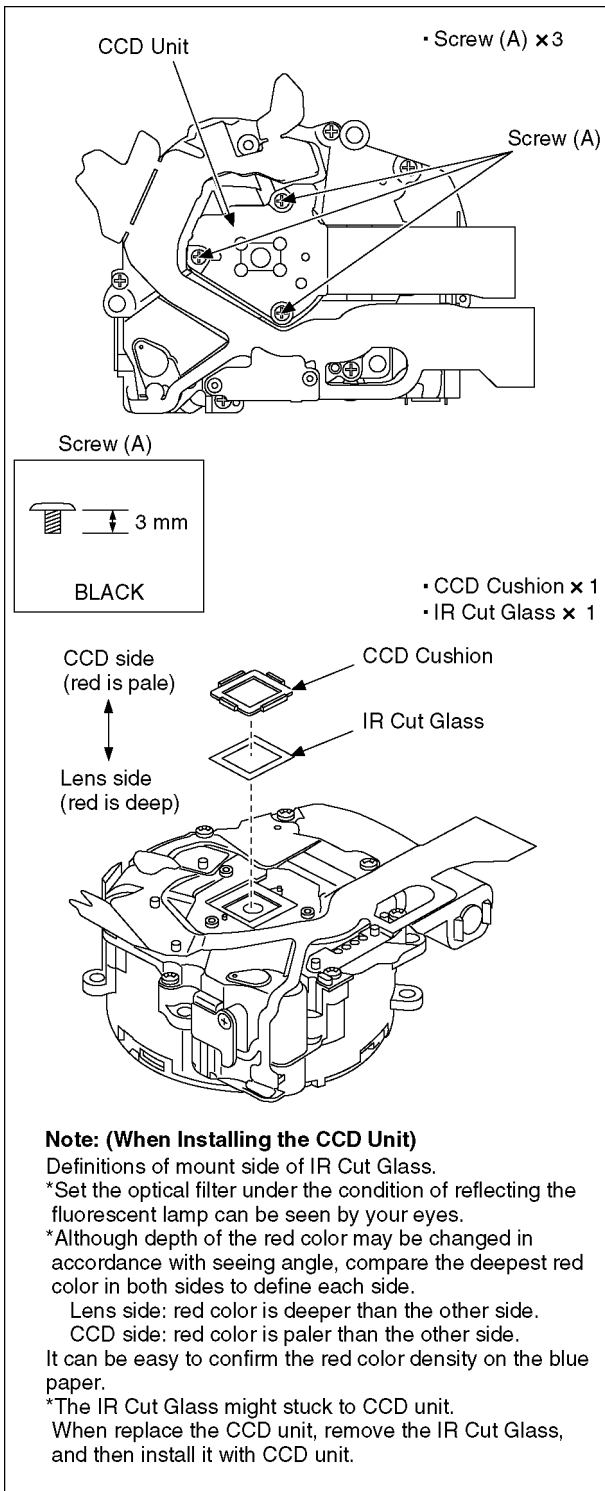

8.7. Removal of the Zoom Motor Unit

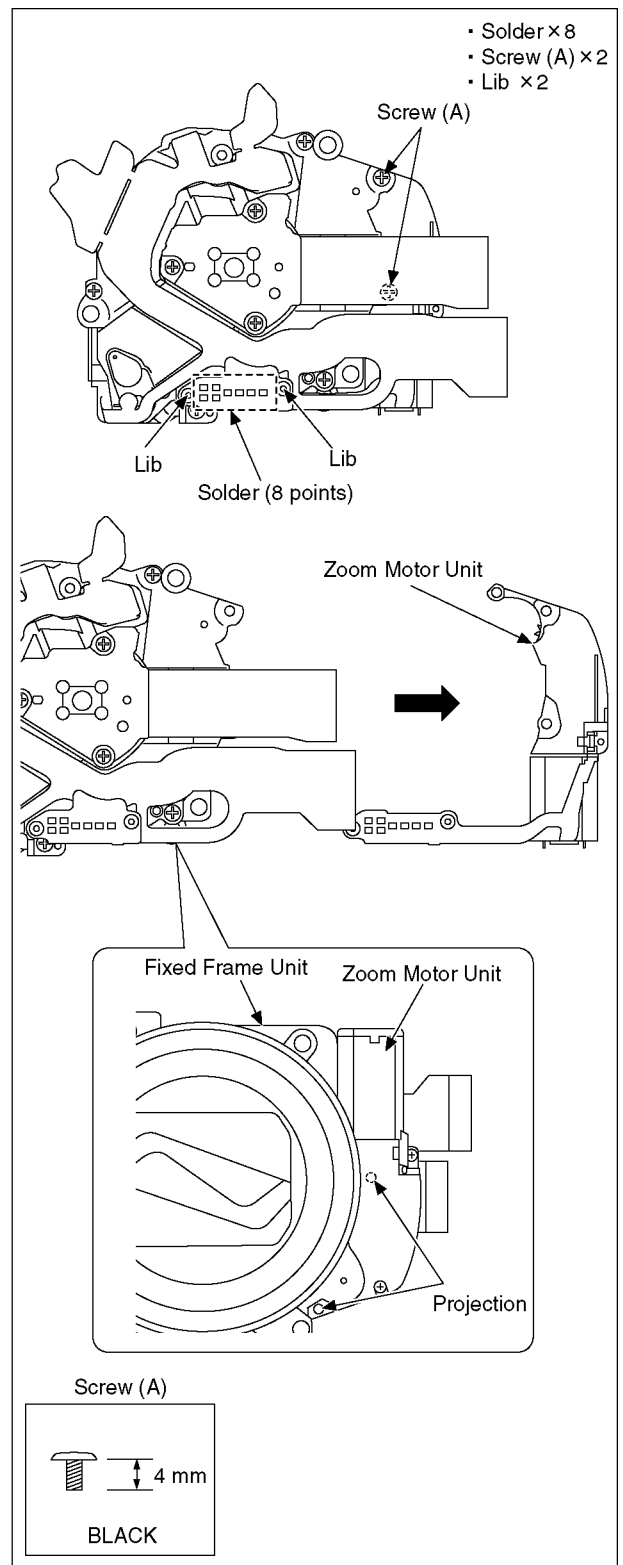

8.8. Removal of the Focus Motor Unit

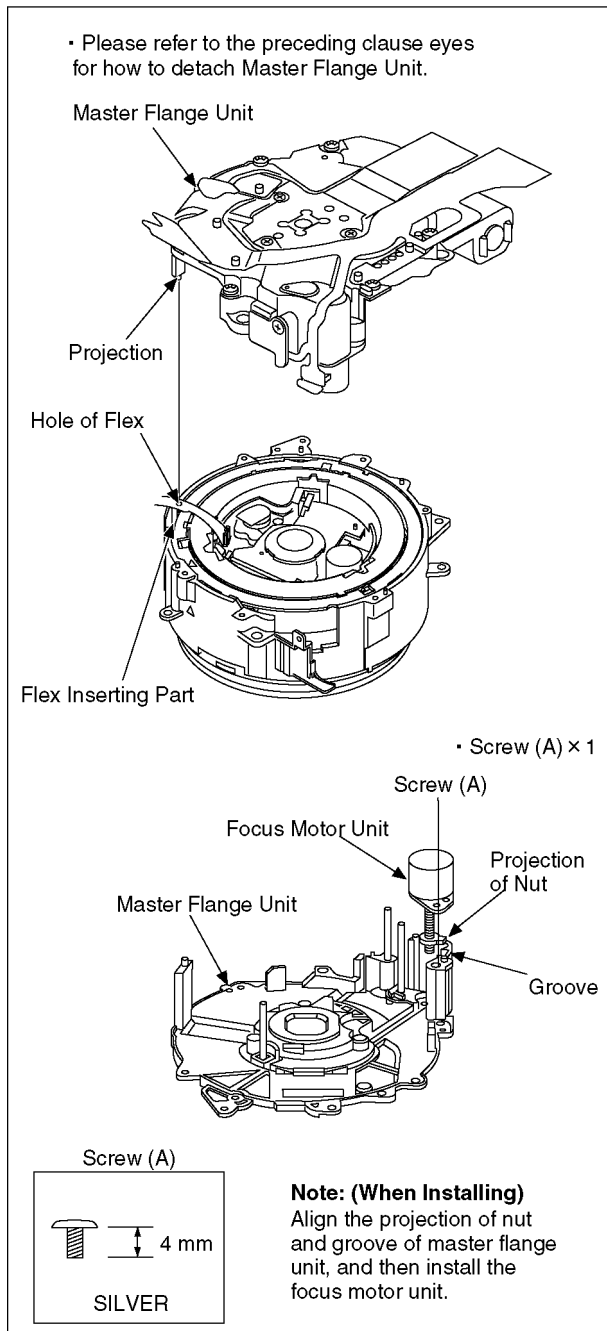

8.9. The Aplyment of Grease Method

The grease apply point of lens unit are as follows.
Apply grease additionally in the specified position if necessary.
When the grease is applied, use a toothpick and apply thinly.

- Focus motor nut moving part
 - Grease: RFKZ0472
 - Amount of apply: 3 - 5 mg
- 4th lens frame positioning pole, guide pole
 - Grease: RFKZ0472
 - Amount of apply: 0.15 - 0.35 mg

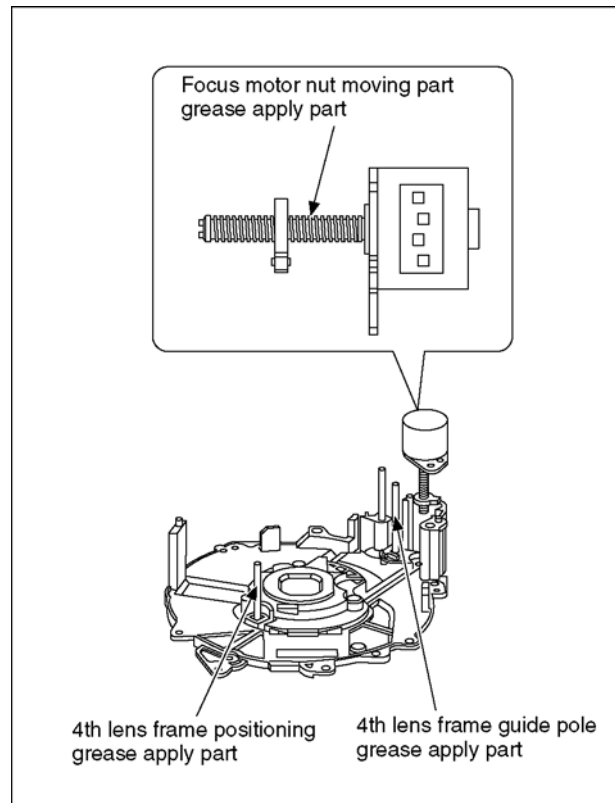

9 Measurements and Adjustments

9.1. Introduction

When servicing this unit, make sure to perform the adjustments necessary based on the part(s) replaced. Before disassembling the unit, it is recommended to back up the camera data stored in flash-rom as a data file.

IMPORTANT NOTICE (After replacing the MAIN P.C.B.)

After replacing the MAIN P.C.B., it is necessary to use the "DIAS" software to allow the release of adjustment flag(s). The Adjustment software "DIAS" is available at "TSN Website". To download, click on "Support Information from NWBG/VDBG-AVC".

*DIAS (DSC Integrated Assist Software)

9.2. Before Disassembling the unit

9.2.1. Initial Setting Release

The cameras specification are initially set in accordance with model suffix (such as EB, EG, GK, GC, and so on.). Unless the initial setting is not released, an automatic alignment software in the camera is not able to be executed when the alignment is carried out.

Note:

The initial setting should be again done after completing the alignment. Otherwise, the camera may not work properly. Therefore as a warning, the camera display a warning symbol " ! " on the LCD monitor every time the camera is turned off. Refer to the procedure described in "3.4.2. INITIAL SETTINGS" for details.

[How to Release the camera initial setting]

Preparation:

Attach the Battery or AC Adaptor with a DC coupler to the unit.
Set the recording mode dial to PROGRAM AE mode.

Step 1. Temporary cancellation of "INITIAL SETTINGS":

Set the REC/PLAYBACK selector switch to "REC"(Camera mark).
While pressing the UP of Cursor button and DISPLAY button simultaneously, turn the power switch to the ON position.

Step 2. Cancellation of "INITIAL SETTINGS":

Set the REC/PLAYBACK selector switch to "PLAYBACK".
While pressing UP of Cursor button and DISPLAY button simultaneously. (The camera will beep after this.)
Turn the Power off. (The warning symbol " ! " is displayed on the LCD monitor.)

9.2.2. Flash-Rom Data Backup

When trouble occurs, it is recommended to backup the Flash-rom data before disassembling the unit. There are two kinds of Flash-rom data backup methods:

[ROM_BACKUP (Method of Non-PC backup)]

1. Insert the SD-card into the camera.
2. Set the camera to "Temporary cancellation of the initial settings".
3. Select the "SETUP" menu.

From the "SETUP" menu, select "ROM BACKUP".

Note:

This item is not listed on the customer's "SET UP" menu.

4. When this "ROM_BACKUP" item is selected, the following submenus are displayed.



Item	Function	Details
DSC → SD	Save all the DSC's Flash-rom data to SD-CARD	<ul style="list-style-type: none"> DSC's Flash-rom data is saved to the SD-CARD as a data file by the same format as the TATSUJIN software for the previous models. (DATA BACKUP) -File location: ROOT DIRECTORY in SD-CARD. -File Name: <ol style="list-style-type: none"> 1) User Setup Information data : <Model Number>U.txt [Example: DMC-FX66 : "FX66U.txt"] 2) Optical Adjustment data : <Model Number>F.txt [Example: DMC-FX66 : "FX66F.txt"] If the concerned file already exists, "OVERWRITE?" message is displayed.
SDALL → DSC (ID CHECK)	Write the all data to DSC's Flash-rom from SD-CARD	<ul style="list-style-type: none"> The backup data being stored in the SD card is transferred to DSC unit. ID CHECK: When the model ID is different, data is not transferred.
SDALL → DSC (FORCE)	Write the all data to DSC's Flash-rom from SD-CARD	<ul style="list-style-type: none"> FORCE: Even if the model ID is different, data is transferred. * If the main PCB is replaced, select "SDALL → DSC(FORCE)".
SDUSER → DSC (FORCE)	Only "User setup information" is written from the saved file in the SD-CARD to DSC's Flash-rom.	<ul style="list-style-type: none"> Only the user's "setup" setting condition is transferred to DSC unit. FORCE: Even if the model ID is different, the data is transferred.
! → LUMIX	Shipping set without initializing "User setup information"	<ul style="list-style-type: none"> Initial setting is executed without initializing the user's set up setting condition. * The initial setting must be perform while the Self-timer LED is blinking, * The picture data stored in the built-in memory of the DSC is not erased, with this operation.

[DSC Integrated Assist Software (Method of Using PC)]

Same as TATSUJIN software for previous models.

9.2.3. Light Box

If using VFK1164TDVLB Light Box, remove the lens connection ring by loosening three hexagon screws.

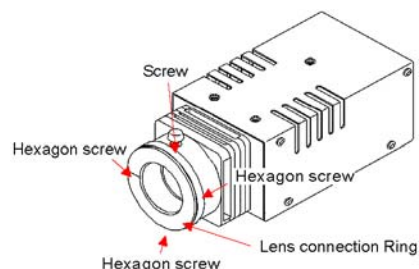

9.3. Details of Electrical Adjustment

9.3.1. How to execute the Electrical Adjustment

It is not necessary to connect the camera to a PC to perform adjustments.

"Flag reset operation" and "Initial setting operation" are required when carrying out the alignment, follow the procedure below.

9.3.1.1. Startup Electrical Adjustment mode

1. Release the initial settings.
2. Insert a recordable SD card.
(Without a SD card, the automatic adjustment can not executed.)
3. Procedure to set the camera into adjustment mode:
 - a. Set the mode into PROGRAM AE mode.
 - b. Set the REC/PLAYBACK selector switch to "REC" (Camera mark).
 - c. Turn the Power SW off.
 - d. Turn the Power SW on pressing DISPLAY and Menu simultaneously.
LCD monitor displays "SERVICE MODE". (Refer to Fig.F3-1)

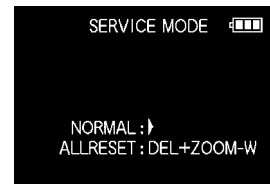

Fig. 3-1

9.3.1.2. Status Adjustment Flag Setting

Reset (Not yet adjusted) the status flag condition.

1. After pressing the Display button, the LCD monitor displays the Flag status screen (Refer to Fig.3-2.)
2. Select item by pressing the cross keys. (Gray cursor is moved accordingly.)
3. Press the Delete button.

Note:

The selected item's flag has been changed from "F (green)" to "0 (yellow)".

*(Refer to Fig. 3-3)

*Flag conditions:

F (green)

means that the alignment has been completed and the status flag condition is set. In this case, the flag condition should be reset, if you try to carry out the automatic alignment.

0 (yellow)

means that the alignment has been not "completed" and the status flag condition is "reset". In this case, automatic alignment is available.



Fig. 3-2



Fig. 3-3

- In case of setting the status flag into set condition again without completion of the alignment, the status flag should be SET by using PC, or UNDO by using ROM BACKUP function.

9.3.1.3. Execute Adjustment

1. Perform step "9.3.1.1." to "9.3.1.2.", to reset the OIS flag status "F" (Set) to "0" (Reset).
2. Press Display button after Flag reset.
OIS Adjustment screen is displayed on the LCD panel.
(Refer to Fig.3-4)
3. Press the shutter button. The adjustment will start automatically.
4. When the adjustment is completed successfully, adjustment report menu appears with Green OK on the LCD monitor. (Refer to Fig.3-5)



Fig. 3-4



Fig. 3-5

9.3.1.4. Attention point during Adjustment

1. Step "9.3.1.3." procedure shows OIS adjustment as an example. To perform the adjustment, refer to the "9.3.2. Adjustment Specifications" table which shows key point for each adjustment.
2. Do not move the light box, the camera or the chart while adjusting. If one of these is moved accidentally, start the adjustment again.
3. Do not press any buttons/keys until the default menu (Fig.3-6) is displayed on the LCD monitor. Otherwise, adjustment data may not be stored properly.
4. If the adjustment is interrupted accidentally, the alignment data may not be properly saved in the Flash-rom.

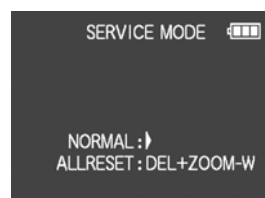

Fig. 3-6

9.3.1.5. Finalizing the Adjustment

1. Several adjustment flags can be reset ("F" into "0") at the same time. In this case, when the adjustment has been completed, the screen will change showing the adjustment for the next item until all reset items are completed.
Also, when the shutter button is pressed, the screen jump to the next adjustment item.
2. To cancel the adjustment mode while in the process of performing the adjustment, follow this procedures.
 - (1) Press DELETE button.
 - (2) Press "Right of cross key" button.

Note:

- *.If adjustment is cancelled with above procedure, adjustment is not completed. Make sure to adjust it later.
- *.Adjustment software "DIAS" is able to control the status of the adjustment flags.

9.3.2. Adjustment Specifications

The following matrix table shows the relation between the replaced part and the Necessary Adjustment. When a part is replaced, make sure to perform the necessary adjustment(s) in the order indicated. The table below shows all the information necessary to perform each adjustment.

Adjustment order	Adjustment Item	FLAG	Purpose	Replacing Parts			JIG/TOOLS	SET UP	How to Operate
				MAIN PCB	Lens Parts (except for CCD)				
					CCD Unit	GYRO (IC9101)			
1	Venus Zoom	PZM	Venus Zoom Inspection	○	—	—	NONE	NONE	1)Press Shutter Button 2)After displaying "PZM", press Shutter Button again. 3)After completed, the "OK" menu appears.
2	OIS sensor	OIS	OIS sensor output level adjustment	○	○	—	NONE	NONE	1)Press Shutter Button (Do not apply any shock and vibration for the camera while adjusting) 2)After completed, the "OK" menu appears.
3	Backfocus / GYRO	BF	To have the focus tracking curve be appropriate shape and GYRO sensor adjustment	○	○	○	*COLLIMATOR (VFK1164TCM02 or VFK1164TCM03 or RFKZ0422)	1)Set the camera in front of collimator so that the distance from collimator to camera becomes about 4 cm as shown in Fig.A. [IMPORTANT] The adjustment "NG" might be happened with the following conditions: - Do not put the black colored stuff at the back side of collimator near hunching chart. It needs to get some certain brightness. - Make sure the hunching chart has no dust and dirty condition. - Do not connect a USB cable during adjustment.	1)Press Shutter Button (Do not apply any shock and vibration for the camera while adjusting) 2)After completed, the "OK" menu appears.
4	Iris	IRS	Iris adjustment	○	○	—	*LIGHT BOX (VFK1164TDVLB or RFKZ0523)	1)Set the camera in front of LIGHT BOX so that the distance from collimator to camera becomes about 8 cm as shown in Fig.B.	1)Press Shutter Button 2)After completed, the "OK" menu appears.
5	Monitor Linearity	MLN	Monitor Linearity adjustment	○	○	—		1)Set the camera in front of LIGHT BOX so that the distance from collimator to camera becomes about 8 cm as shown in Fig.B.	1)Press Shutter Button 2)After completed, the "OK" menu appears.
6	Shutter	SHT	Shutter speed adjustment	○	○	—		1) Insert the TR chart into the slot of LIGHT BOX. 2) Set the camera in front of LIGHT BOX so that the distance from LIGHT BOX to camera becomes about 12 cm as shown in Fig.B.	1)Press Shutter Button 2)After completed, the "OK" menu appears.
7	ISO	ISO	ISO sensitivity adjustment	○	○	—		3) Set the camera angle so that the color chart is displayed on the LCD monitor fully. [IMPORTANT] The adjustment "NG" might be happened with the following conditions: - Since the lens position is automatically set into certain position after executing auto adjustment, confirm the angle after stopping the lens zoom position. - It is no problem even though the chart on to the LCD monitor slightly cut at the corner. - It is no problem even though the focusing slightly becomes out of focusing condition. - Not connect the USB cable at this stage.	1)Press Shutter Button 2)After completed, the "OK" menu appears.
8	White Balance	WBL	White balance adjustment under various color temperature	○	○	—	*LIGHT BOX (VFK1164TDVLB or RFKZ0523) *TR CHART (RFKZ0443)		1)Press Shutter Button 2)After completed, the "OK" menu appears.
9	High brightness coloration	LIN	High brightness coloration adjustment	○	○	—			1)Press Shutter Button 2)After completed, the "OK" menu appears.
10	CCD Missing Pixels (White)	WKI	Compensation of CCD Missing Pixels (White)	○	—	○	NONE	NONE	1)Press Shutter Button 2)After completed, the "OK" menu appears.
11	Color reproduction inspection and Microphone check	COL	Color reproduction inspection and Microphone check	○	○	—	NONE	Right after pressing the shutter button, enter the continuous sounds (voice) to the microphone until lens unit starting the zooming.	1)Press Shutter Button. Right after pressing the shutter button, make a continuous sound (voice) to the microphone until lens unit starting the zooming. 2)After completed, the "OK" menu appears.
12	CCD Missing Pixels (Black)	BKI	Compensation of CCD Missing Pixels (Black)	○	—	○	*LIGHT BOX (VFK1164TDVLB or RFKZ0523)	1)Set the camera in front of LIGHT BOX so that the distance from collimator to camera becomes about 8 cm as shown in Fig.B.	1)Press Shutter Button 2)After completed, the "OK" menu appears.

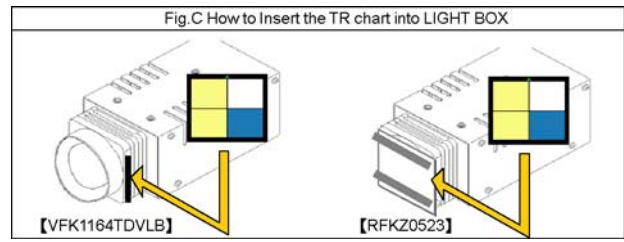
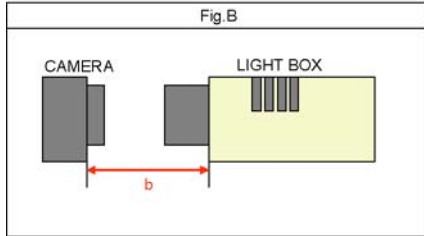
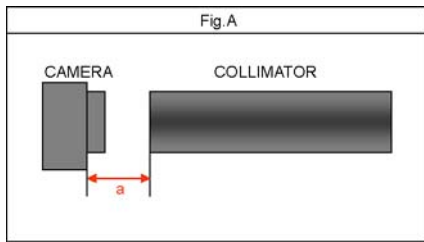

n IMPORTANT NOTICE (After replacing the MAIN P.C.B.)

After replacing the MAIN P.C.B., make sure to perform the "INITIAL SETTINGS" first, then release the "INITIAL SETTINGS" in order to proceed the electrical adjustment.

Note:

1. If electrical adjustment or data re-writing is executed before "INITIAL SETTINGS", suffix code list is never displayed, and it cannot be chosen suitable suffix code.
2. Never remove the battery during initial setting in process.

9.4. After Adjustment

9.4.1. Initial Setting

Since the initial setting has been released to execute the built-in adjustment software, it should be set up again before shipping the camera to the customer.

Refer to the procedure described in "3.4.2. INITIAL SETTINGS" for details.

[IMPORTANT]

1. The initial setting should be done again after completing the alignment. Otherwise, the camera will not work properly.
Therefore as a warning, the camera display a warning symbol " ! " on the LCD monitor every time the camera is turned off.
2. Confirm that status of all adjustment flag show "F". Even if one of the adjustment flag shows "0", initial setting programmed is never executed.
3. Adjustment software "DIAS" is able to control the status of the adjustment flags.
The Adjustment software "DIAS" is available at "TSN Website", therefore, access to "TSN Website" at "Support Information from NWBG/VDBG-AVC".

10 Maintenance

10.1. Cleaning Lens, Viewfinder and LCD Panel

Do not touch the surface of lens, Viewfinder and LCD Panel with your hand.

When cleaning the lens, use air-Blower to blow off the dust.

When cleaning the LCD Panel, dampen the lens cleaning paper with lens cleaner, and the gently wipe the their surface.

Note:

The Lens Cleaning KIT; VFK1900BK(Only supplied as 10 set/Box) is available as Service Aid.

Service Manual

Diagrams and Replacement Parts List

Digital Camera

Model No.

DMC-TZ8EB	DMC-TZ8GN
DMC-TZ8EE	DMC-ZS5P
DMC-TZ8EF	DMC-ZS5PC
DMC-TZ8EG	DMC-ZS5PU
DMC-TZ8EP	DMC-ZS5GH
DMC-TZ8GC	DMC-ZS5GK

Vol. 1
 Colour
 (S).....Silver Type (except DMC-TZ8EF)
 (K).....Black Type

Table of contents

S1. About Indication of The Schematic Diagram.....	S-1	S5. Print Circuit Board.....	S-10
S1.1. Important Safety Notice.....	S-1	S5.1. SD P.C.B.....	S-10
S2. Voltage Chart.....	S-2	S5.2. Gyro P.C.B.....	S-10
S2.1. Gyro P.C.B.....	S-2	S5.3. Top Operation P.C.B.....	S-11
S2.2. Top Operation P.C.B.....	S-2	S5.4. Flash P.C.B.....	S-12
S2.3. Flash P.C.B.....	S-2	S5.5. CCD Flex P.C.B.....	S-13
S3. Block Diagram.....	S-3	S5.6. Lens Flex P.C.B.....	S-14
S3.1. Overall Block Diagram.....	S-3	S6. Replacement Parts List.....	S-15
S4. Schematic Diagram.....	S-4	S7. Exploded View.....	S-19
S4.1. Interconnection Diagram.....	S-4	S7.1. Frame and Casing Section.....	S-19
S4.2. SD Card (SD) Schematic Diagram.....	S-5	S7.2. Packing Parts and Accessories Section.....	S-20
S4.3. Gyro Schematic Diagram.....	S-5		
S4.4. Top Operation Schematic Diagram.....	S-6		
S4.5. Flash Schematic Diagram.....	S-7		
S4.6. CCD Flex Schematic Diagram.....	S-8		
S4.7. Lens Flex Schematic Diagram.....	S-9		

S1. About Indication of The Schematic Diagram

S1.1. Important Safety Notice

COMPONENTS IDENTIFIED WITH THE MARK \triangle HAVE THE SPECIAL CHARACTERISTICS FOR SAFETY. WHEN REPLACING ANY OF THESE COMPONENTS USE ONLY THE SAME TYPE.

1. Although reference number of the parts is indicated on the P.C.B. drawing and/or schematic diagrams, it is NOT mounted on the P.C.B. when it is displayed with "\$" mark.
2. It is only the "Test Round" and no terminal (Pin) is available on the P.C.B. when the TP (Test Point) indicated as "●" mark.
3. The voltage being indicated on the schematic diagram is measured in "Standard-Playback" mode when there is no specify mode is mentioned.
4. Although the voltage and waveform available on here is measured with standard frame, it may be differ from actual measurement due to modification of circuit and so on.
5. The voltage being indicated here may be include observational-error (deviation) due to internal-resistance and/or reactance of equipment. Therefore, handle the value indicated on here as reference.
6. Use the parts number indicated on the Replacement Parts List .
7. Indication on Schematic diagrams:

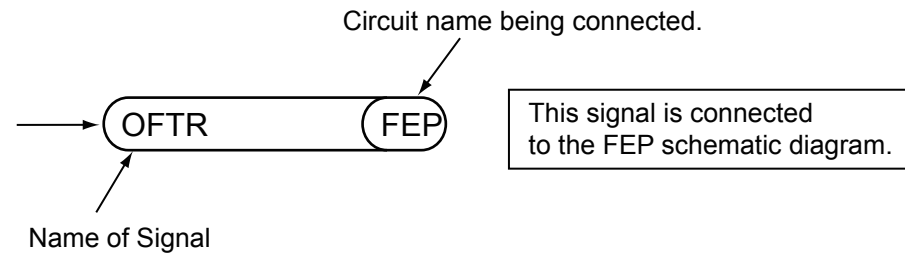

S2. Voltage Chart

Note) Indicated voltage values are the standard values for the unit measured by the DC electronic circuit tester (high-impedance) with the chassis taken as standard. Therefore, there may exist some errors in the voltage values, depending on the internal impedance of the DC circuit tester.

S2.1. Gyro P.C.B.

REF No.	PIN No.	POWER ON
IC9701	1	-
IC9701	2	-
IC9701	3	-
IC9701	4	0
IC9701	5	1.4
IC9701	6	1.4
IC9701	7	0
IC9701	8	3.1

S2.2. Top Operation P.C.B.

REF No.	PIN No.	POWER ON
IC7301	1	-
IC7301	2	-
IC7301	3	-
IC7301	4	0
IC7301	5	1.4
IC7301	6	1.4
IC7301	7	0
IC7301	8	3.1

S2.3. Flash P.C.B.

REF No.	PIN No.	POWER ON
IC8101	1	0
IC8101	2	0
IC8101	3	0
IC8101	4	0
IC8101	5	3.4
IC8101	6	0
IC8101	7	0
IC8101	8	0
IC8101	9	3.1
IC8101	10	3.8

S3. Block Diagram

S3.1. Overall Block Diagram

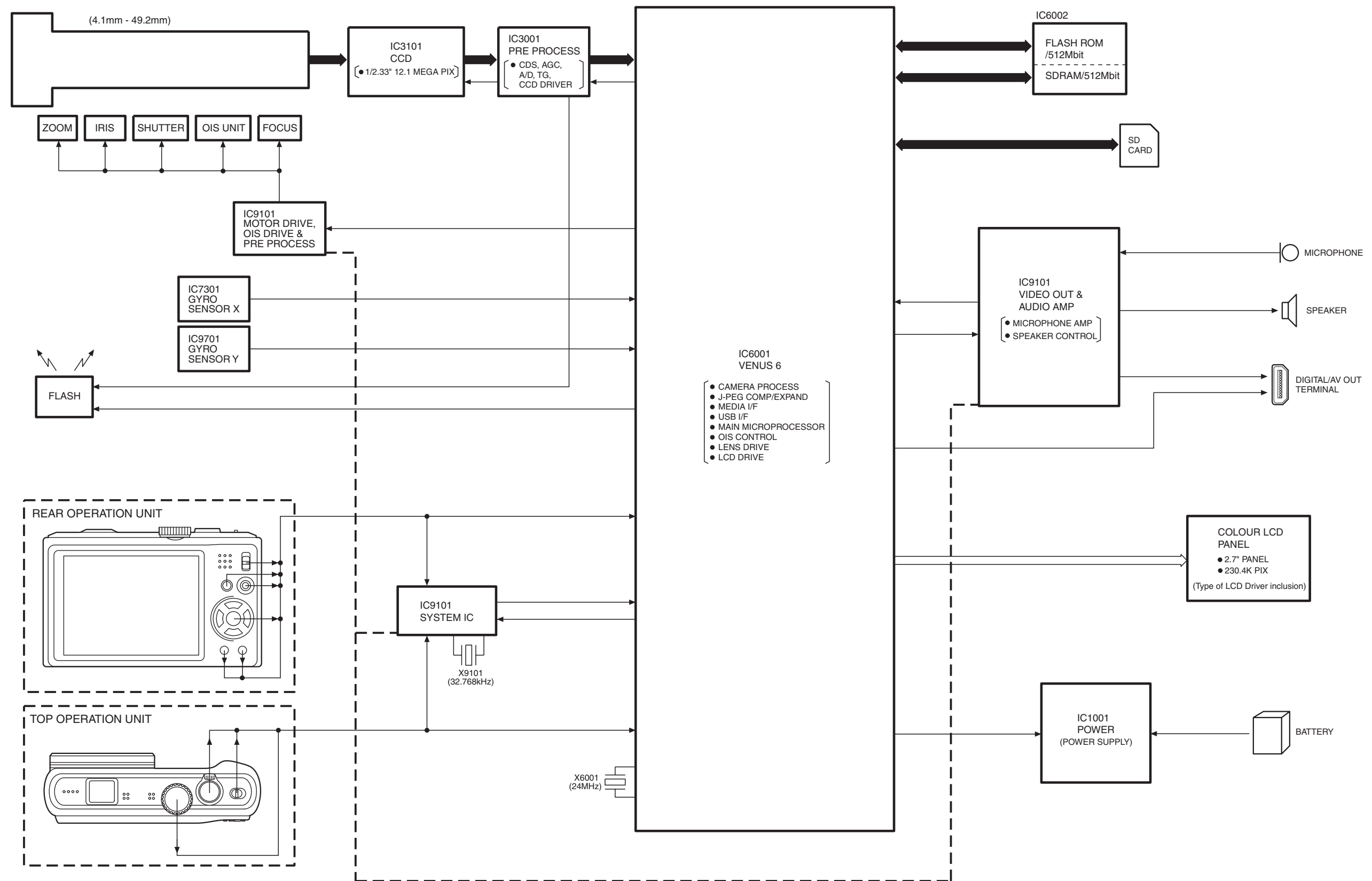

DMC-TZ8/ZS5 OVERALL BLOCK DIAGRAM

S4. Schematic Diagram

S4.1. Interconnection Diagram

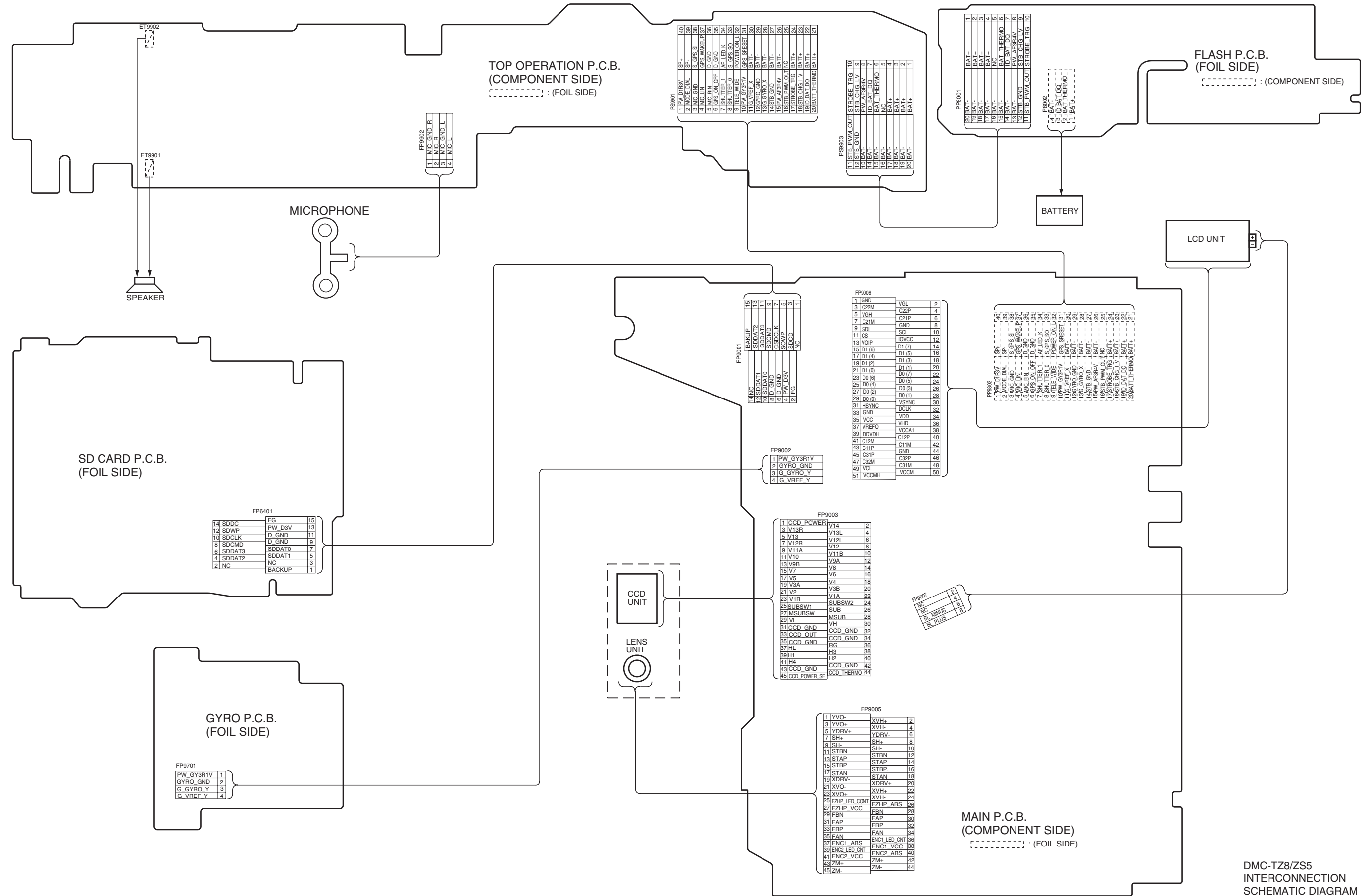

DMC-TZ8/ZS5
INTERCONNECTION
SCHEMATIC DIAGRAM

S4.2. SD Card (SD) Schematic Diagram / S4.3. Gyro Schematic Diagram

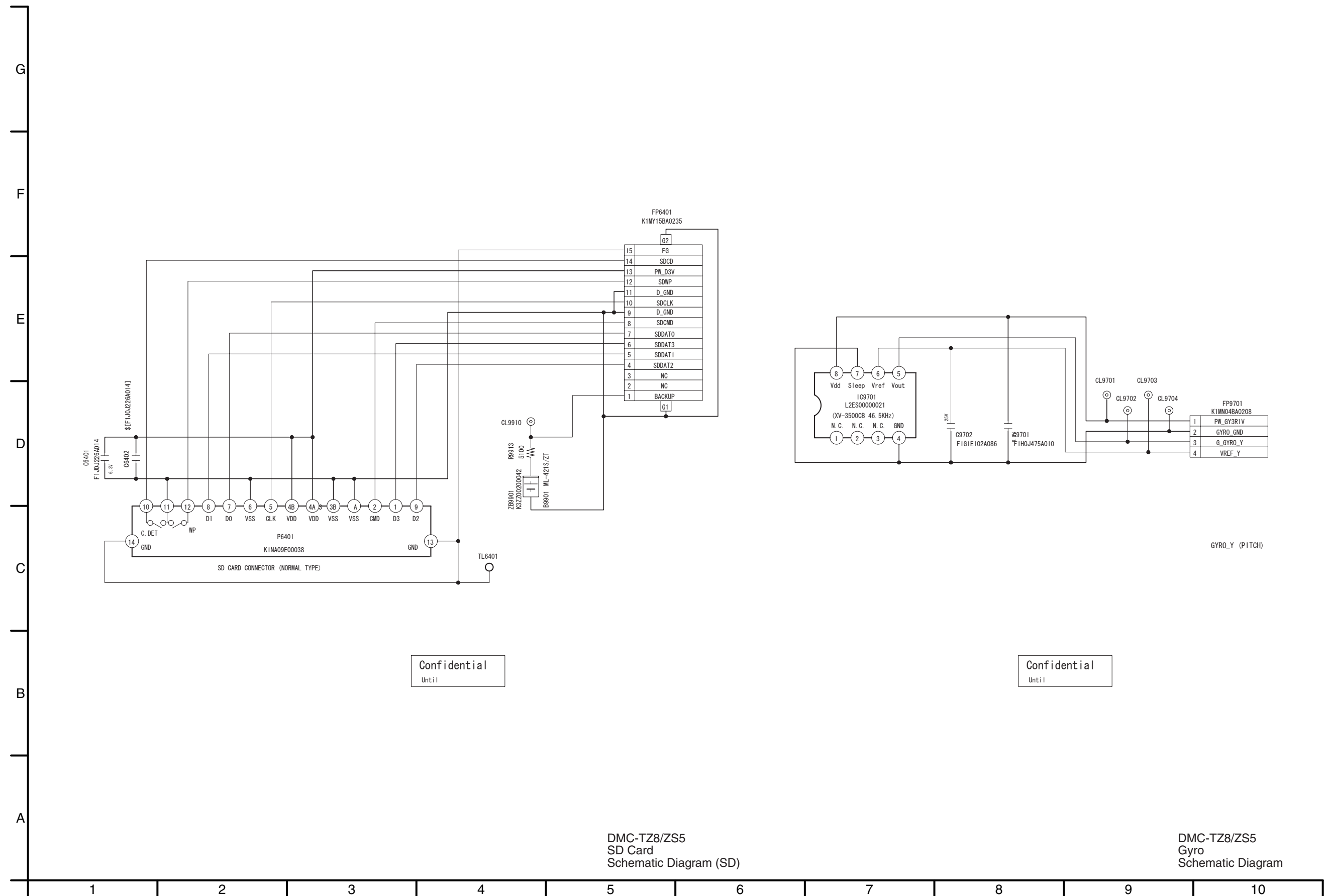

S4.4. Top Operation Schematic Diagram

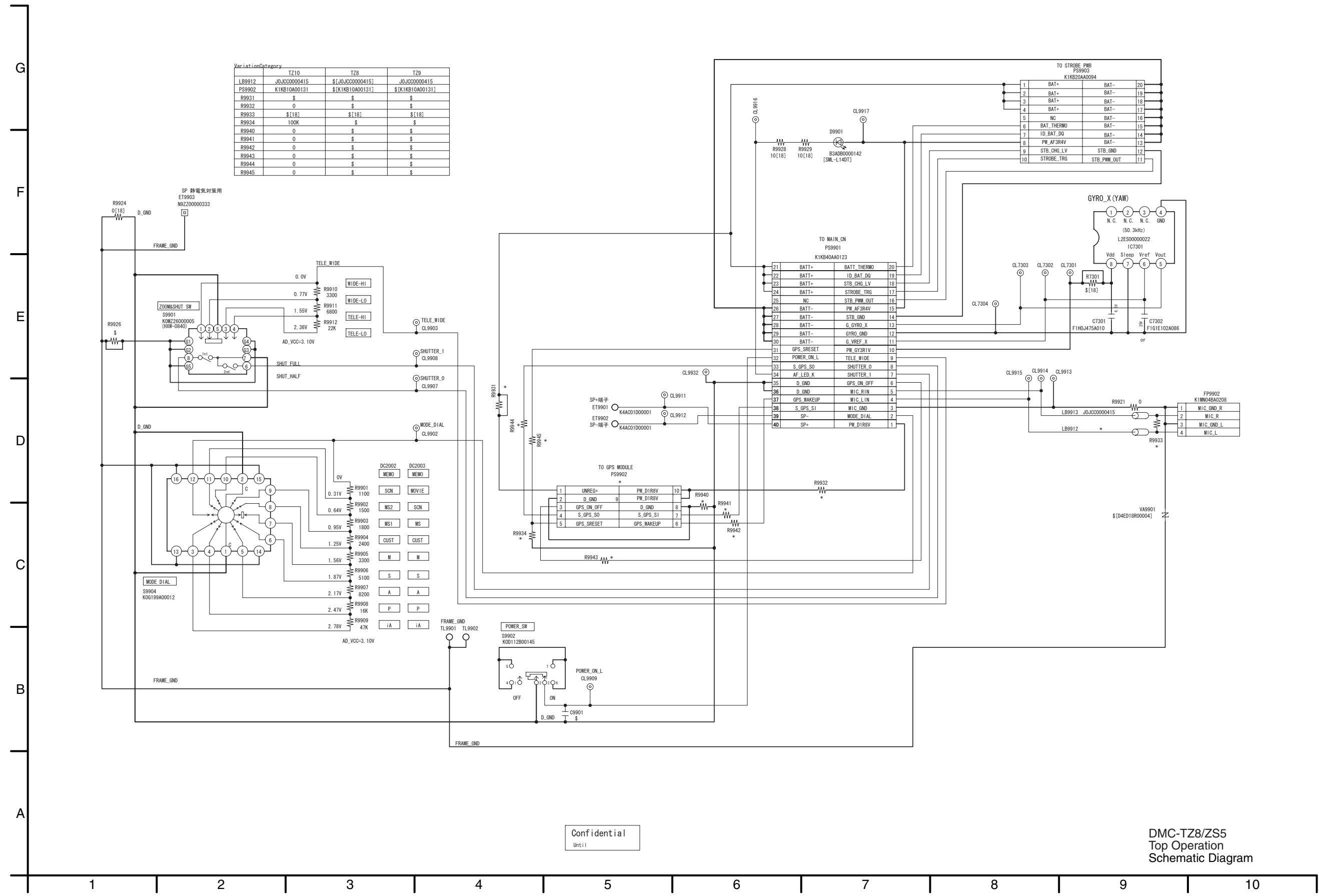

Confidential
Until

DMC-TZ8/ZS5
Top Operation
Schematic Diagram

S4.5. Flash Schematic Diagram

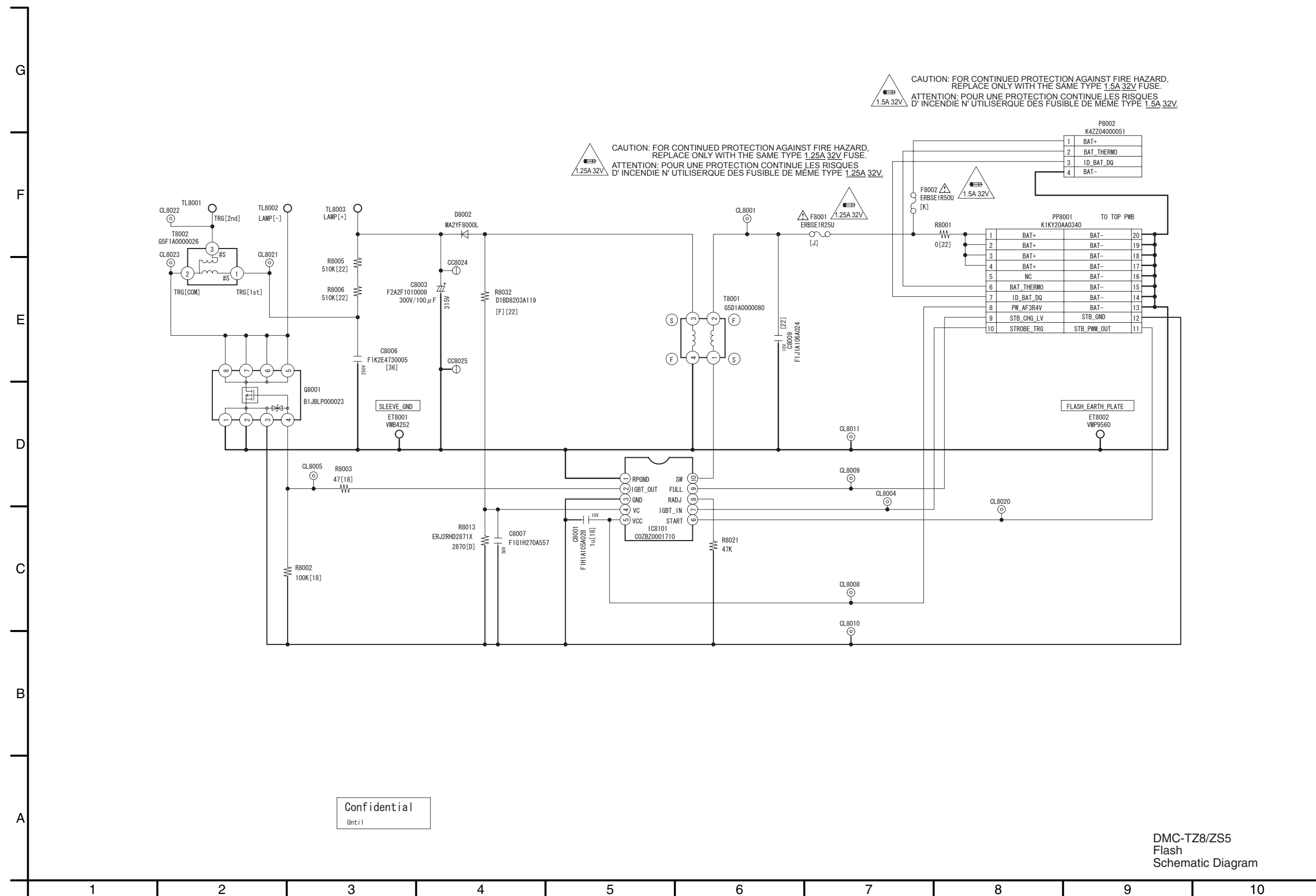

Confidential
Until

S4.6. CCD Flex Schematic Diagram

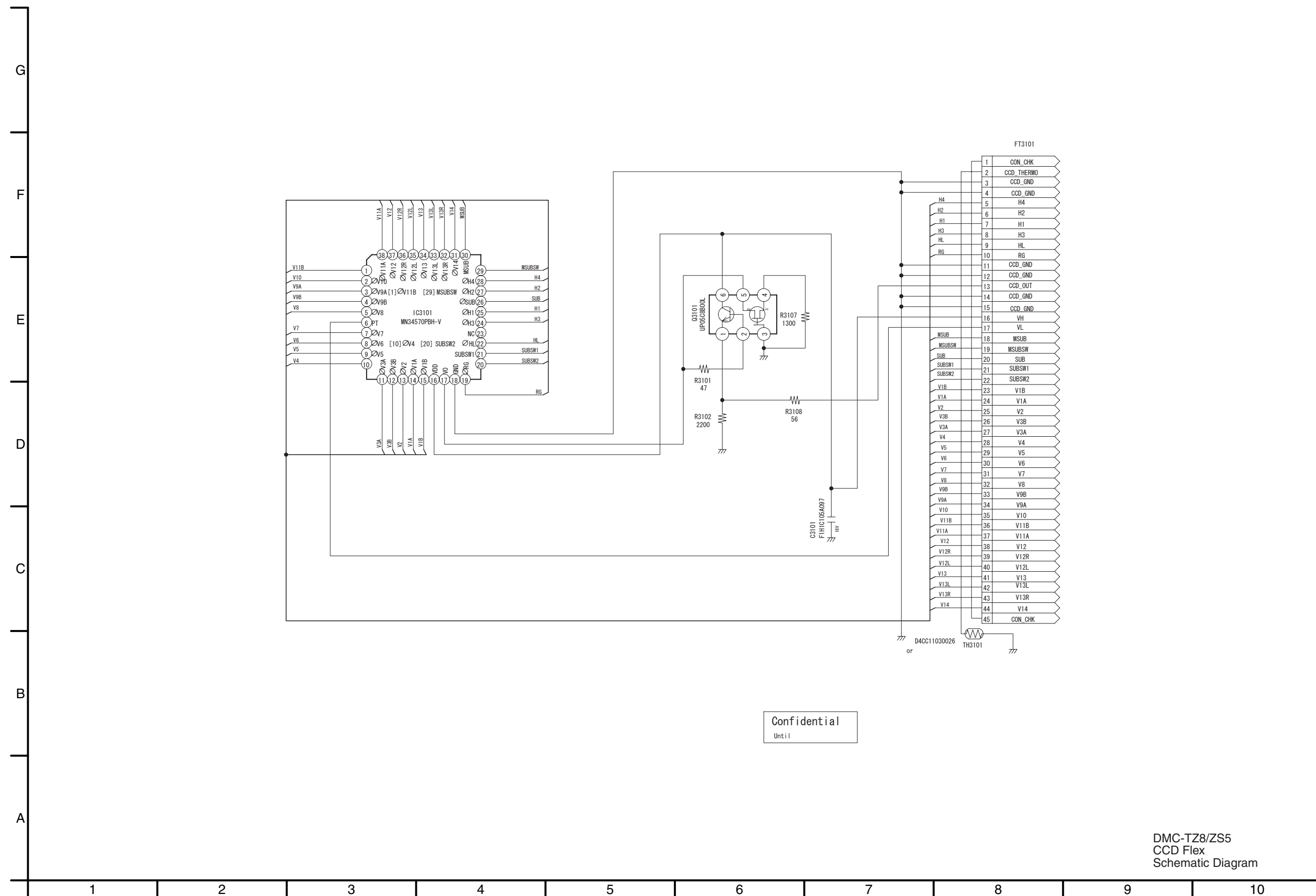

Confidential
Until

S4.7. Lens Flex Schematic Diagram

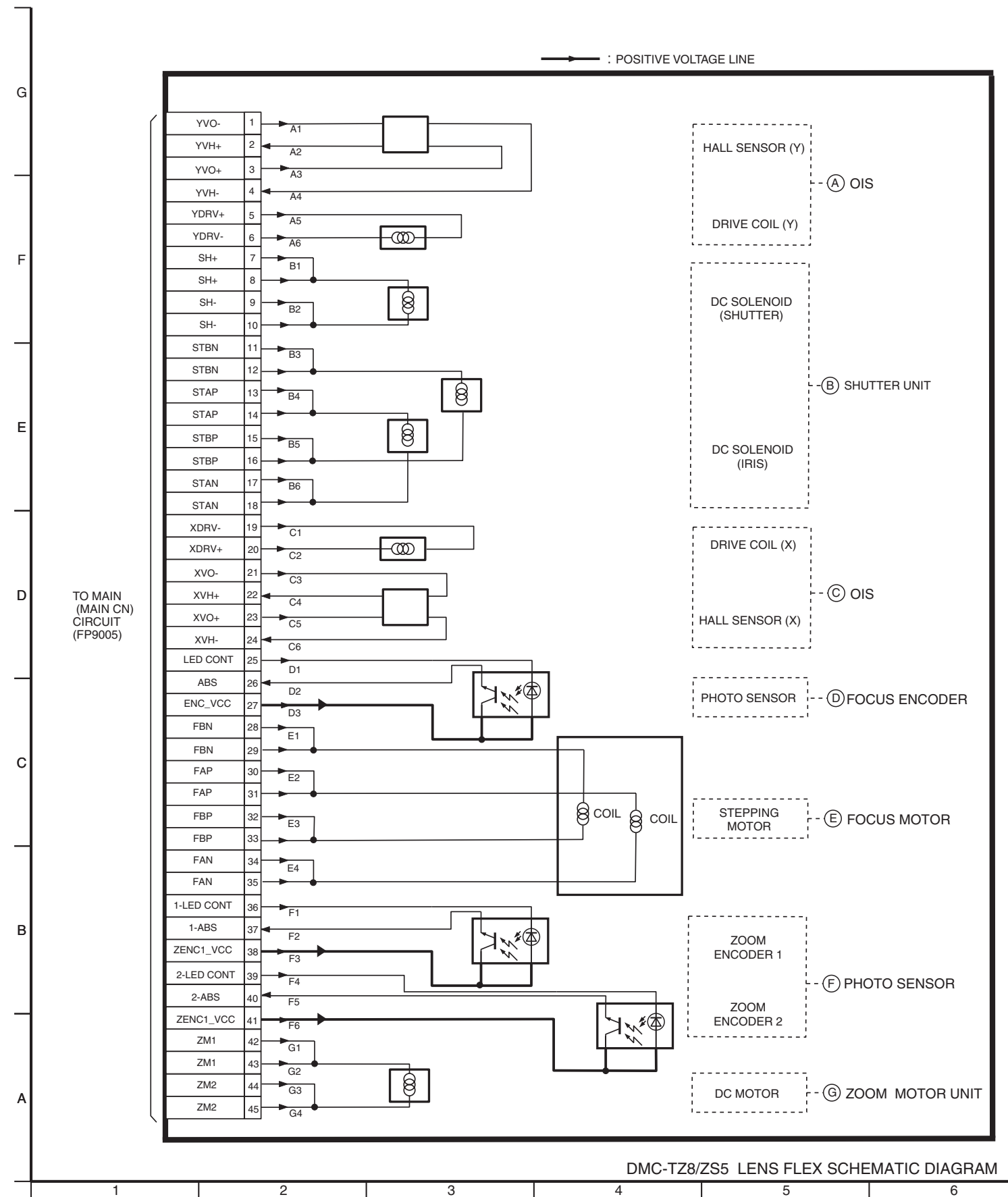

S5. Print Circuit Board

S5.1. SD P.C.B. / S5.2. Gyro P.C.B.

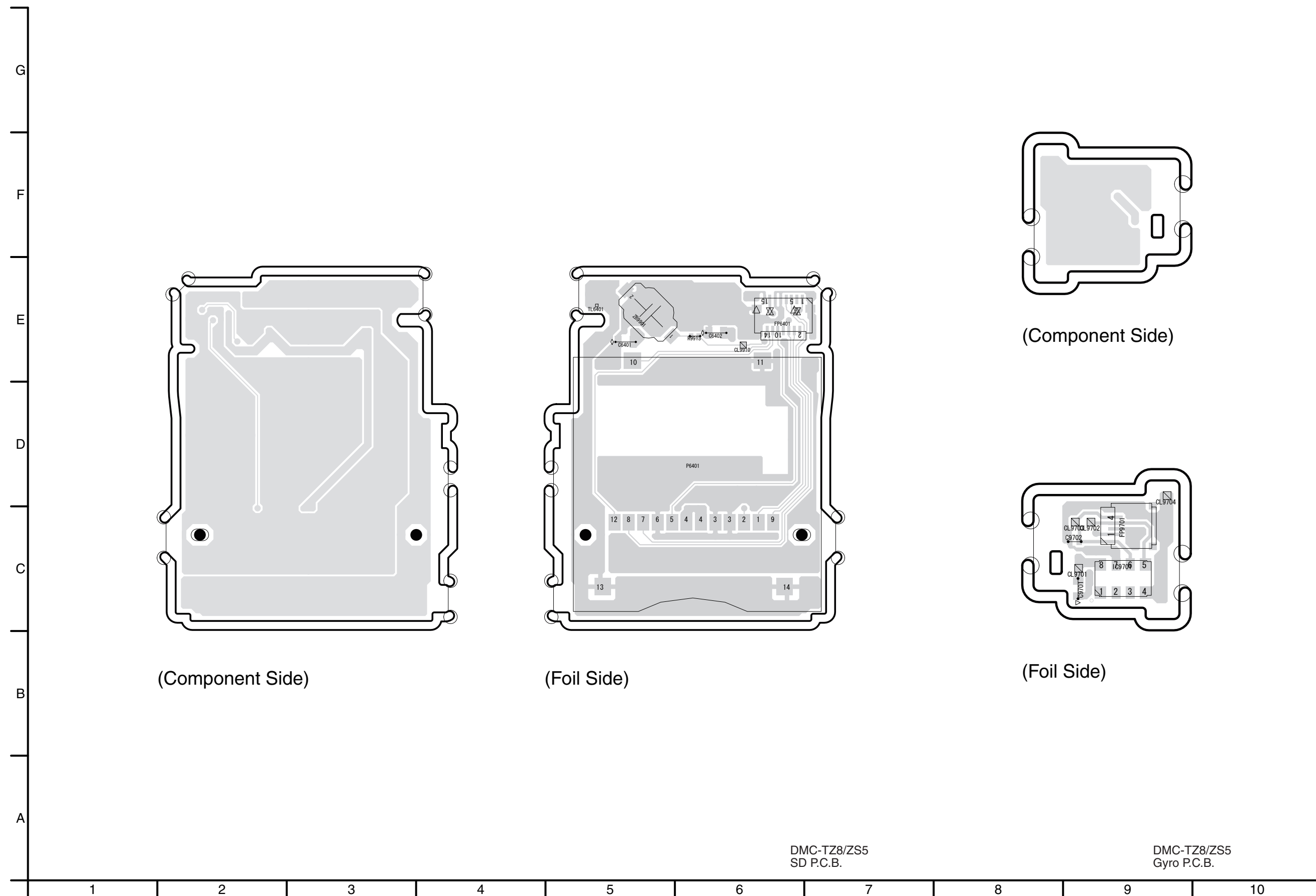

(Component Side)

(Foil Side)

(Component Side)

(Foil Side)

DMC-TZ8/ZS5
SD P.C.B.

DMC-TZ8/ZS5
Gyro P.C.B.

S5.3. Top Operation P.C.B.

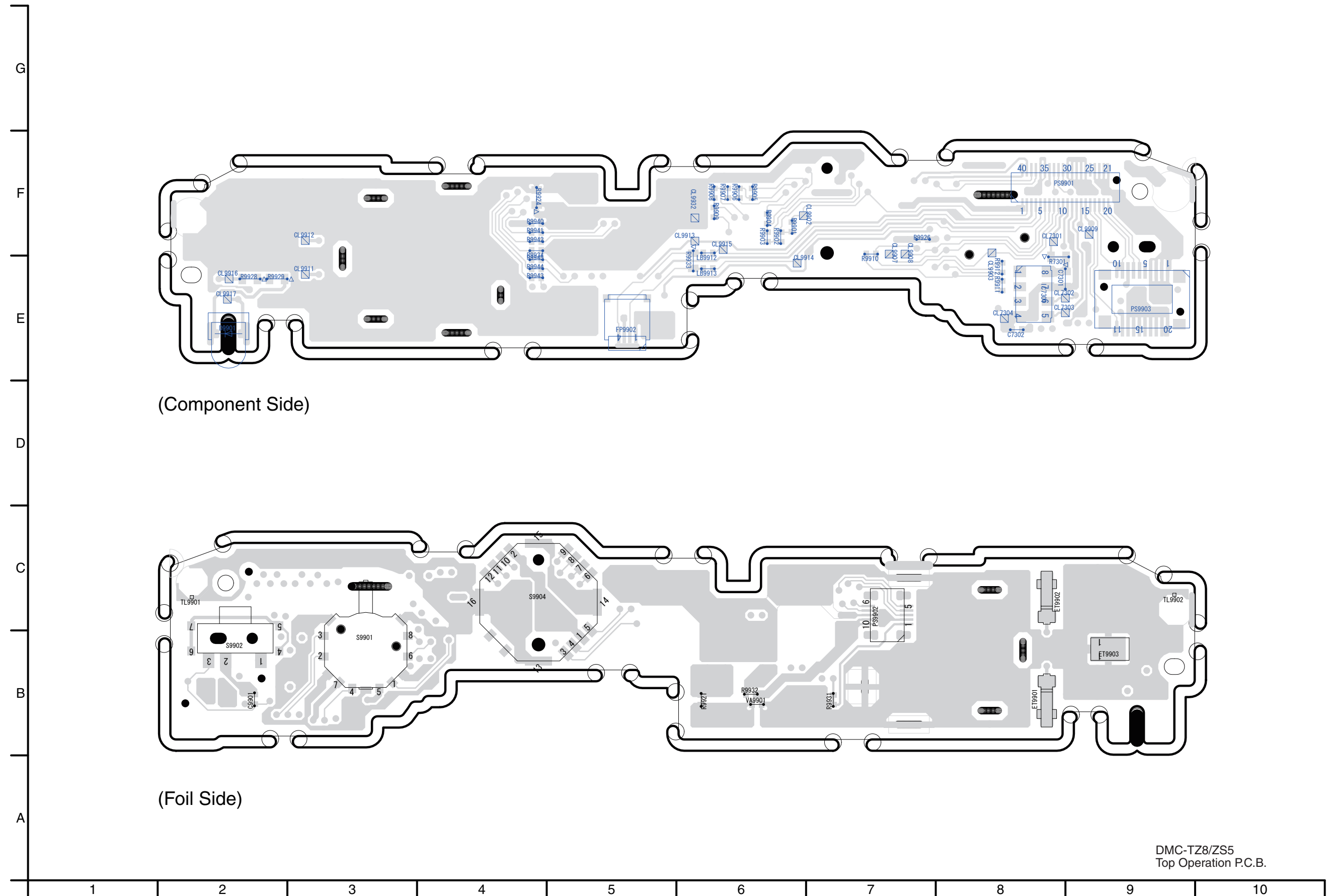

(Component Side)

(Foil Side)

S5.4. Flash P.C.B.

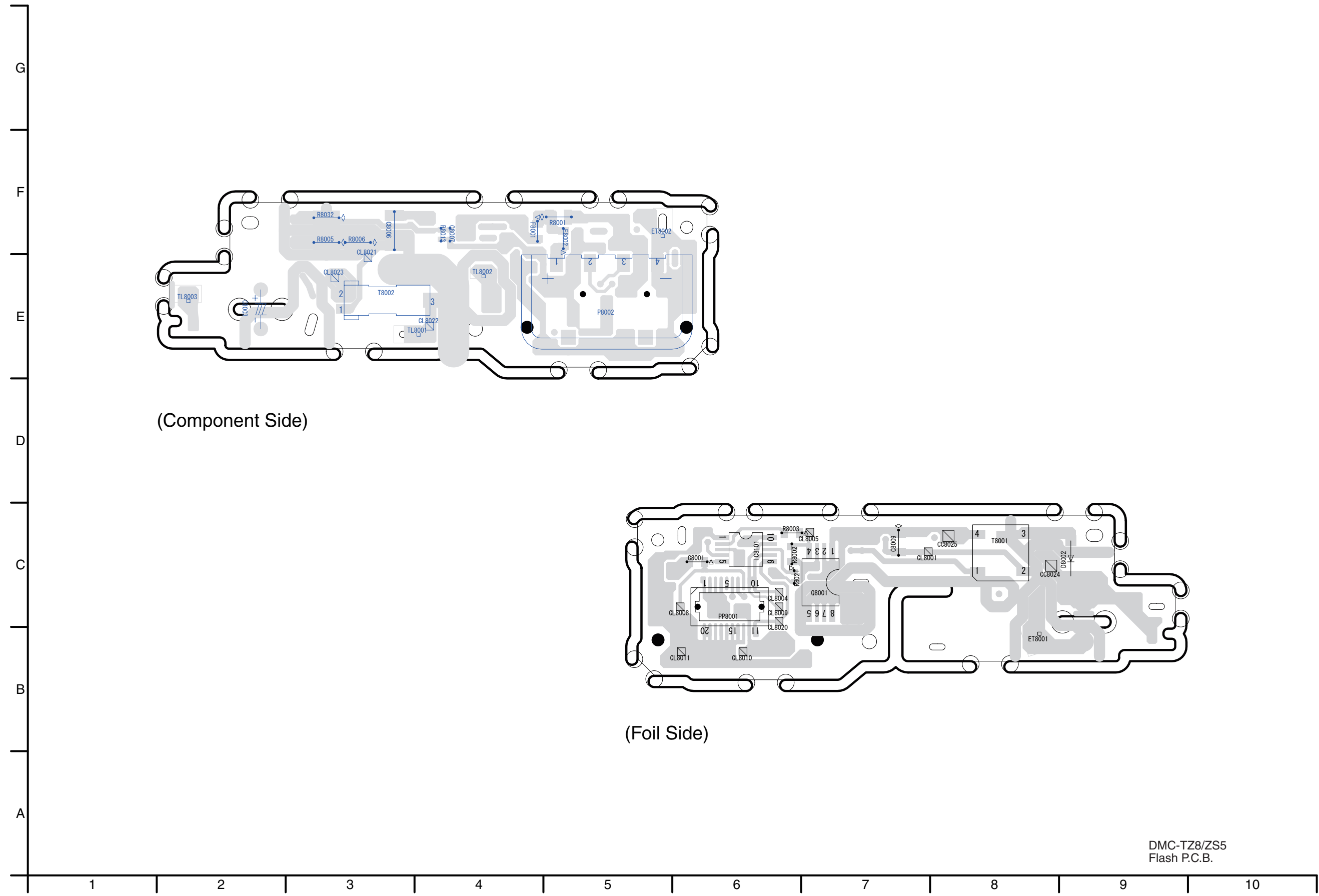

DMC-TZ8/ZS5
Flash P.C.B.

S5.5. CCD Flex P.C.B.

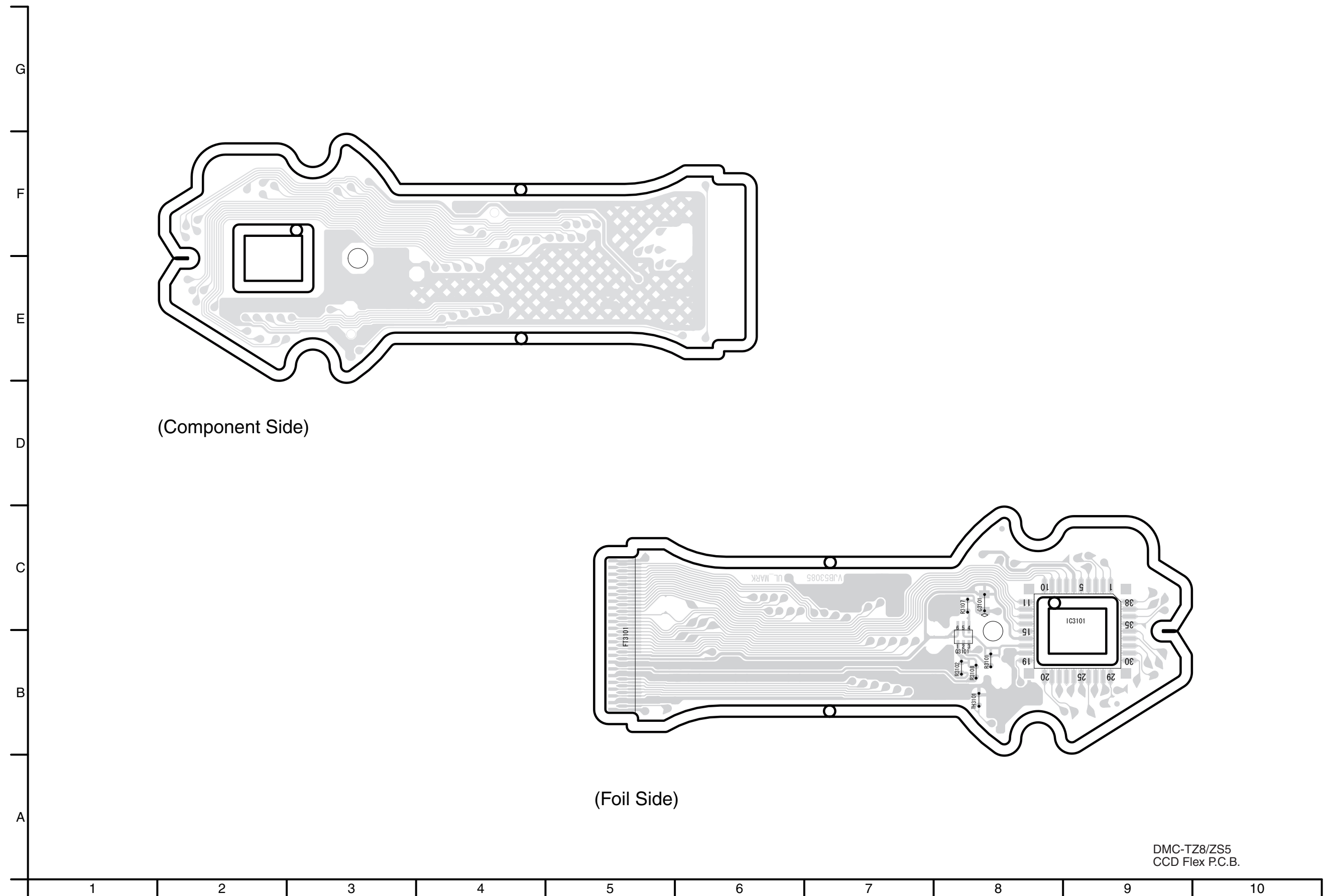

DMC-TZ8/ZS5
CCD Flex P.C.B.

S5.6. Lens Flex P.C.B.

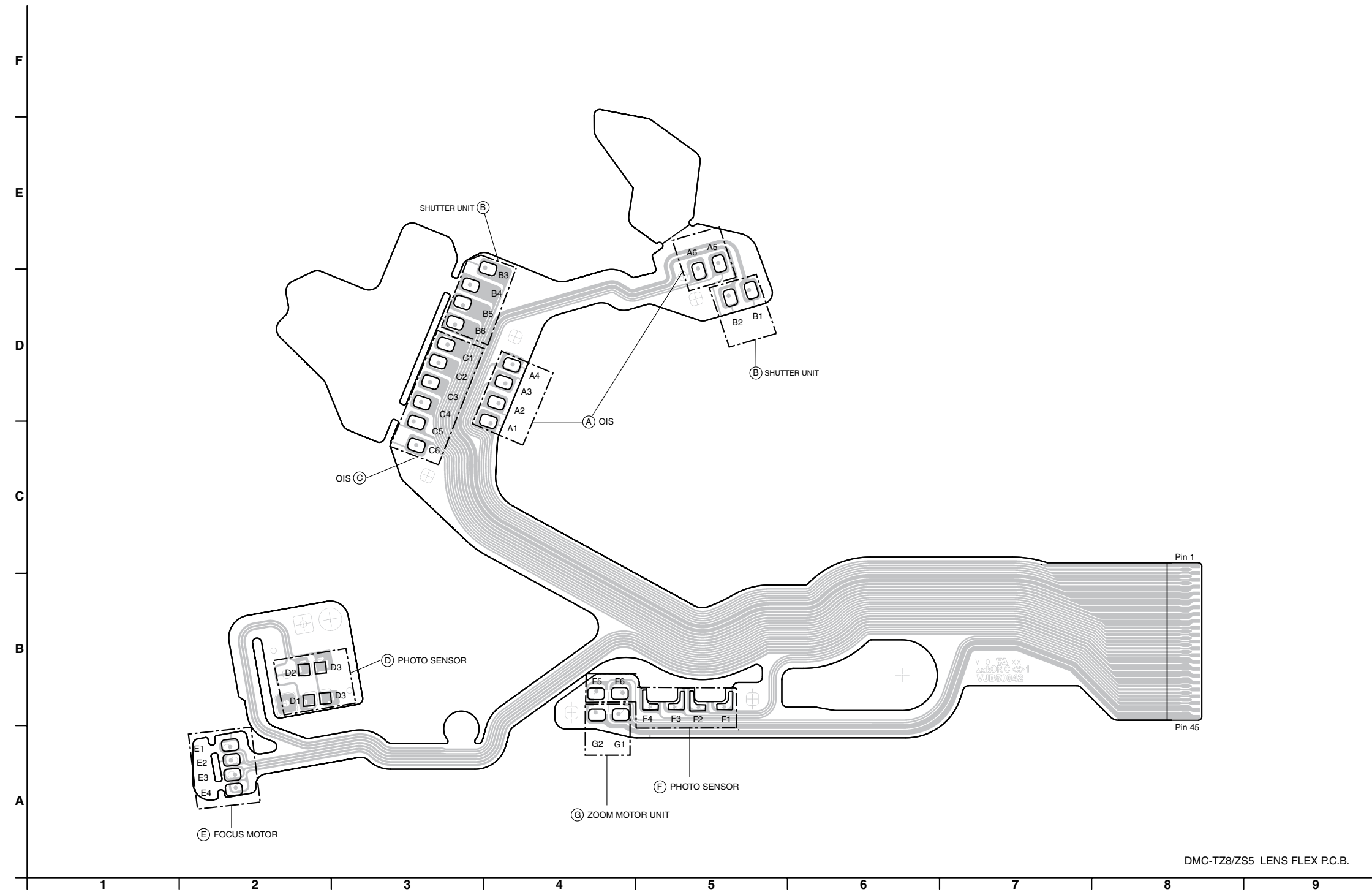

DMC-TZ8/ZS5 LENS FLEX P.C.B.

S6. Replacement Parts List

- Note:
1. *Be sure to make your orders of replacement parts according to this list.
 2. **IMPORTANT SAFETY NOTICE**
Components identified with the mark \triangle have the special characteristics for safety.
When replacing any of these components, use only the same type.
 3. Unless otherwise specified,
All resistors are in OHMS, K=1,000 OHMS. All capacitors are in MICRO-FARADS (uf), P=uuF.
 4. The marking (RTL) indicates the retention time is limited for this item. After the discontinuation of this assembly in production, it will no longer be available.
 5. Supply of CD-ROM, in accordance with license protection, is allowable as replacement parts only for customers who accidentally damaged or lost their own.

E.S.D. standards for Electrostatically Sensitive Devices, refer to PREVENTION OF ELECTROSTATIC DISCHARGE (ESD) TO ELECTROSTATICALLY SENSITIVE (ES) DEVICES section.

Definition of Parts supplier:

1. **Parts marked with [ENERGY] in the remarks column are supplied from Panasonic Corporation Energy Company.**

Ref.No.	Part No.	Part Name & Description	Pcs	Remarks
##	VEP56102A	MAIN P.C.B.	1	(RTL) E.S.D.
##	VEP51026A	SD CARD P.C.B.	1	(RTL) E.S.D.
##	VEP50063A	GYRO P.C.B.	1	(RTL) E.S.D.
##	VEP50059B	TOP OPERATION P.C.B.	1	(RTL) E.S.D.
##	VEP58112A	FLASH P.C.B.	1	(RTL) E.S.D.
##	VEK0P93	CCD U	1	
##	VEP51026A	SD CARD P.C.B.		(RTL) E.S.D.
C6402	F1J0J226A014	C.CAPACITOR CH 6.3V 22U	1	
FP6401	K1MY15BA0235	CONNECTOR 15P	1	
P6401	K1NA09E00038	CONNECTOR 9P	1	
R9913	ERJ2GEJ512X	M.RESISTOR CH 1/16W 5.1K	1	
ZB9901	K3ZZ00200042	BATTERY HOLDER	1	
##	VEP50063A	GYRO P.C.B.		(RTL) E.S.D.
C9701	F1H0J475A010	C.CAPACITOR CH 6.3V 4.7U	1	
C9702	F1G1H1020008	C.CAPACITOR CH 50V 1000P	1	
FP9701	K1MN04BA0208	CONNECTOR 4P	1	
IC9701	L2ES00000021	IC	1	E.S.D.
##	VEP50059B	TOP OPERATION P.C.B.		(RTL) E.S.D.
C7301	F1H0J475A010	C.CAPACITOR CH 6.3V 4.7U	1	
C7302	F1G1E102A086	C.CAPACITOR CH 25V 1000P	1	
D9901	B3ADB0000142	DIODE	1	E.S.D.
ET9901	K4AC01D00001	EARTH SPRING	1	
ET9902	K4AC01D00001	EARTH SPRING	1	
ET9903	N9ZZ00000333	EARTH SPRING	1	
FP9902	K1MN04BA0208	CONNECTOR 4P	1	
IC7301	L2ES00000022	IC	1	E.S.D.
LB9913	J0JCC0000415	FILTER	1	
PS9901	K1KB40AA0123	CONNECTOR 40P	1	
PS9903	K1KB20AA0094	CONNECTOR 20P	1	
R9901	ERJ2GEJ112	M.RESISTOR CH 1/16W 1.1K	1	
R9902	ERJ2GEJ152	M.RESISTOR CH 1/16W 1.5K	1	
R9903	ERJ2GEJ182	M.RESISTOR CH 1/10W 1.8K	1	
R9904	ERJ2GEJ242	M.RESISTOR CH 1/16W 2.4K	1	
R9905	ERJ2GEJ332	M.RESISTOR CH 1/16W 3.3K	1	
R9906	ERJ2GEJ512X	M.RESISTOR CH 1/16W 5.1K	1	
R9907	ERJ2GEJ822	M.RESISTOR CH 1/10W 8.2K	1	
R9908	ERJ2GEJ163	M.RESISTOR CH 1/16W 16K	1	
R9909	ERJ2GEJ473	M.RESISTOR CH 1/16W 47K	1	
R9910	ERJ2GEJ332	M.RESISTOR CH 1/16W 3.3K	1	
R9911	ERJ2RHD682X	M.RESISTOR CH 1/10W 6.8K	1	
R9912	ERJ2GEJ223	M.RESISTOR CH 1/16W 22K	1	
R9921	D0YAR0000007	M.RESISTOR CH 1/10W 0	1	
R9924	ERJ3GEY0R00	M.RESISTOR CH 1/10W 0	1	
R9928	ERJ3GEYJ100	M.RESISTOR CH 1/10W 10	1	
R9929	ERJ3GEYJ100	M.RESISTOR CH 1/10W 10	1	
S9901	K0MZ26000005	SWITCH	1	
S9902	K0D112B00145	SWITCH	1	
S9904	K0G199A00012	SWITCH	1	

Ref.No.	Part No.	Part Name & Description	Pcs	Remarks
##	VEP58112A	FLASH P.C.B.		(RTL) E.S.D.
C8001	ECJ1VB1A105K	C.CAPACITOR CH 10V 1U	1	
C8006	F1K2E4730005	C.CAPACITOR 250V 0.047U	1	
C8007	F1G1H270A557	C.CAPACITOR CH 50V 27P	1	
C8009	F1J1A106A024	C.CAPACITOR CH 10V 10U	1	
D8002	MA2YF8000L	DIODE	1	E.S.D.
△ F8001	ERBSE1R25U	FUSE 32V 1.25A	1	
△ F8002	ERBSE1R50U	FUSE 32V 1.5A	1	
IC8101	C0ZBZ0001710	IC	1	E.S.D.
P8002	K4ZZ04000051	CONNECTOR 4P	1	
PP8001	K1KY20AA0340	CONNECTOR 20P	1	
Q8001	B1JBLP000023	TRANSISTOR	1	E.S.D.
R8001	ERJ6GEY0R00V	M.RESISTOR CH 1/8W 0	1	
R8002	ERJ3GEYJ104	M.RESISTOR CH 1/10W 100K	1	
R8003	ERJ3GEYJ470	M.RESISTOR CH 1/10W 47	1	
R8005	ERJ6GEYJ514	M.RESISTOR CH 1/10W 514K	1	
R8006	ERJ6GEYJ514	M.RESISTOR CH 1/10W 514K	1	
R8013	ERJ2RHD2871	M.RESISTOR CH 1/16W 2870	1	
R8021	ERJ2GEJ473	M.RESISTOR CH 1/16W 47K	1	
R8032	D1BD8203A119	SURFACE MOUNTING PRECISIO	1	
T8001	G5D1A0000080	TRANSFORMER	1	
T8002	G5F1A0000026	INDUCTOR	1	
##	VEK0P93	CCD U		
C3101	F1H1C105A097	C.CAPACITOR CH 16V 1U	1	
Q3101	UP05C8B00L	TRANSISTOR	1	E.S.D.
R3101	ERJ2GEJ470	M.RESISTOR CH 1/16W 47	1	
R3102	ERJ2GEJ222	M.RESISTOR CH 1/10W 2.2K	1	
R3107	ERJ2GEJ132	M.RESISTOR CH 1/10W 1.3K	1	
R3108	ERJ2GEJ560X	M.RESISTOR CH 1/10W 56	1	
TH3101	D4CC11030026	THERMISTORS	1	
		---- OTHER ELECTRICAL PART -----		
ET8001	VMB4252	EARTH SPRING	1	
ET8002	VMP9560	FLASH EARTH PLATE	1	

Ref.No.	Part No.	Part Name & Description	Pcs	Remarks
301	VPF1386	CAMERA BAG	1	
△ 302	DE-A66AA	BATTERY CHARGER	1	EG,EB,EF,EP,GN
△ 302	DE-A66BB	BATTERY CHARGER	1	EE,GC,GH,GK
△ 302	DE-A65BA	BATTERY CHARGER	1	P,PC,PU
303	VQL2C67	OPERATING LABEL	1	PC
△ 304	----	BATTERY PACK	1	EG,EB,EE,EF,EP,GC,GN,PU, GH (Not supplied)
△ 304	----	BATTERY PACK	1	P,PC (Not supplied)
△ 304	----	BATTERY PACK	1	GK (Not supplied)
305	K1HA08AD0002	USB CABLE	1	
306	K1HA08CD0028	AV CABLE	1	
307	VFC4297	HAND STRAP	1	
△ 308	VFF0599-S	CD-ROM (SOFT AND INSTRUCTION BOOK)	1	EG,EB,EF,EP See "Notes"
△ 308	VFF0600-S	CD-ROM (SOFT AND INSTRUCTION BOOK)	1	EE See "Notes"
△ 308	VFF0601-S	CD-ROM (SOFT AND INSTRUCTION BOOK)	1	GC,GN,GH See "Notes"
△ 308	VFF0598-S	CD-ROM (SOFT AND INSTRUCTION BOOK)	1	P,PC,PU See "Notes"
△ 308	VFF0602-S	CD-ROM (SOFT AND INSTRUCTION BOOK)	1	GK See "Notes"
310	YGQ0E45	BATTERY CARRYING CASE	1	
311	VPK4367	PACKING CASE	1	EGS,EBS,EES,EPS,GCS,GNS
311	VPK4371	PACKING CASE	1	EGK,EBK,EEK,EFK,EPK,GCK, GNK
311	VPK4366	PACKING CASE	1	PS,PCS
311	VPK4370	PACKING CASE	1	PK,PCK
311	VPK4368	PACKING CASE	1	PUS,GHS
311	VPK4372	PACKING CASE	1	PUK,GHK
311	VPK4369	PACKING CASE	1	GKS
311	VPK4373	PACKING CASE	1	GKK
313	VPN6998	CUSHION	1	EG,EB,EE,EF,EP,GC,GN,PU, GH,GK
313	VPN7016	CUSHION	1	P,PC
314	VPF1230	POLYETHYLENE COVER	1	
△ 315	VQT2S94	BASIC O/I	1	EG (GERMAN/FRENCH)
△ 315	VQT2S95	BASIC O/I	1	EG (ITALIAN/DUTCH)
△ 315	VQT2S96	BASIC O/I	1	EG (SPANISH/PORTUGUESE)
△ 315	VQT2S97	BASIC O/I	1	EG (TURKISH)
△ 315	VQT2T02	BASIC O/I	1	EB (ENGLISH)
△ 315	VQT2T03	BASIC O/I	1	EE (RUSSIAN/UKRAINIAN)
△ 315	VQT2T01	BASIC O/I	1	EF (FRENCH)
△ 315	VQT2S98	BASIC O/I	1	EP (SWEDISH/DANISH)
△ 315	VQT2S99	BASIC O/I	1	EP (POLISH/CZECH)
△ 315	VQT2T00	BASIC O/I	1	EP (HUNGARIAN/FINNISH)
△ 315	VQT2T04	BASIC O/I	1	GC,GH (ENGLISH/ CHINESE(TRADITIONAL))
△ 315	VQT2T05	BASIC O/I	1	GC (ARABIC/PERSIAN)
△ 315	VQT2T07	BASIC O/I	1	GN (ENGLISH)
△ 315	VQT2S91	BASIC O/I	1	P (ENGLISH/SPANISH)
△ 315	VQT2S92	BASIC O/I	1	PC (ENGLISH/CANADIAN FRENCH)
△ 315	VQT2S93	BASIC O/I	1	PU (SPANISH/PORTUGUESE)
△ 315	VQT2T06	BASIC O/I	1	GK (CHINESE(SIMPLIFIED))
△ 317	K2CQ29A00002	AC CORD	1	EG,EE,EF,EP,GC
△ 317	K2CT39A00002	AC CORD	1	EB,GC,GH
△ 317	K2CJ29A00002	AC CORD	1	GN
△ 317	K2CA2YY00070	AC CORD	1	GK

Ref.No.	Part No.	Part Name & Description	Pcs	Remarks
△ 318	VQT2K39	O/I SOFTWARE	1	EG (GERMAN/ITALIAN/FRENCH/ DUTCH/SPANISH/PORTUGUESE)
△ 318	VQT2K42	O/I SOFTWARE	1	EB,GN (ENGLISH)
△ 318	VQT2K43	O/I SOFTWARE	1	EE (RUSSIAN/UKRAINIAN)
△ 318	VQT2K41	O/I SOFTWARE	1	EF (FRENCH)
△ 318	VQT2K40	O/I SOFTWARE	1	EP (FINNISH/SWEDISH/DANISH/ POLISH/CZECH/HUNGARIAN)
△ 318	VQT2K44	O/I SOFTWARE	1	GC,GH (ENGLISH/ CHINESE(TRADITIONAL)/ ARABIC/PERSIAN)
△ 318	VQT2K37	O/I SOFTWARE	1	P,PC (ENGLISH/CANADIAN FRENCH)
△ 318	VQT2K38	O/I SOFTWARE	1	PU (SPANISH/PORTUGUESE)
△ 318	VQT2K89	O/I SOFTWARE	1	GK (CHINESE(SIMPLIFIED))

S7. Exploded View

S7.1. Frame and Casing Section

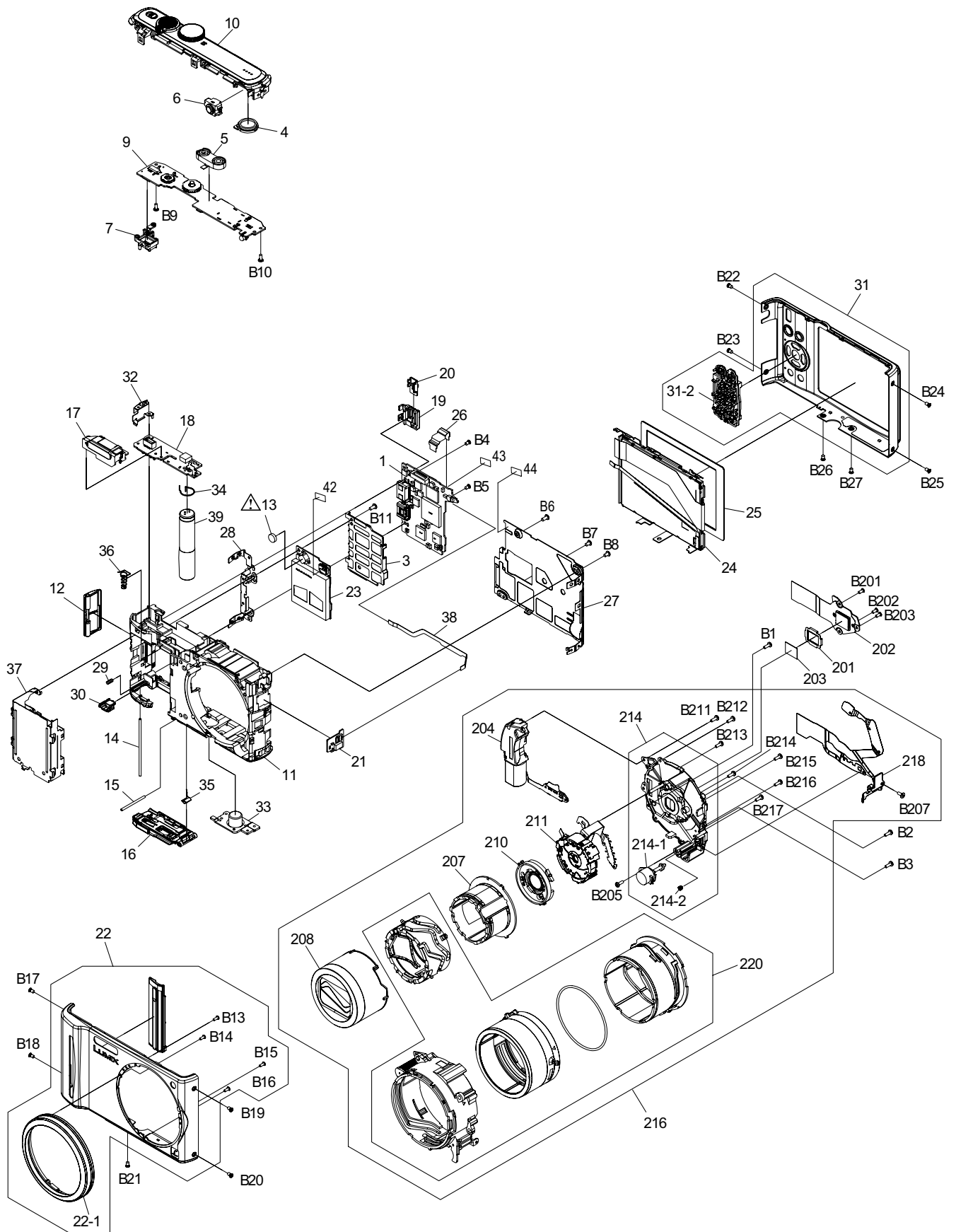

S7.2. Packing Parts and Accessories Section

