

Panasonic®

ORDER NO.DSC1602001CE

B26

Service Manual

Digital Camera

- Model No. **DMC-TZ80EB**
DMC-TZ80EE
DMC-TZ80EF
DMC-TZ80EG
DMC-TZ80EP
DMC-TZ80GA
DMC-TZ80GC
DMC-TZ80GN
DMC-TZ81EG
DMC-ZS60P
DMC-ZS60PP
DMC-ZS60GH

Product Color

Colours

(S).....Silver Type (Except GC)

(K).....Black Type



 **WARNING**

This service information is designed for experienced repair technicians only and is not designed for use by the general public. It does not contain warnings or cautions to advise non-technical individuals of potential dangers in attempting to service a product. Products powered by electricity should be serviced or repaired only by experienced professional technicians. Any attempt to service or repair the product or products dealt with in this service information by anyone else could result in serious injury or death.

© Panasonic Corporation 2016.

Unauthorized copying and distribution is a violation of law.

1 Safety Precautions

1.1 General Guidelines

1. **IMPORTANT SAFETY NOTICE**
There are special components used in this equipment which are important for safety. These parts are marked by Δ in the Schematic Diagrams, Circuit Board Layout, Exploded Views and Replacement Parts List. It is essential that these critical parts should be replaced with manufacturer's specified parts to prevent X-RADIATION, shock fire, or other hazards. Do not modify the original design without permission of manufacturer.
2. An Isolation Transformer should always be used during the servicing of AC Adaptor whose chassis is not isolated from the AC power line. Use a transformer of adequate power rating as this protects the technician from accidents resulting in personal injury from electrical shocks. It will also protect AC Adaptor from being damaged by accidental shorting that may occur during servicing.
3. When servicing, observe the original lead dress. If a short circuit is found, replace all parts which have been overheated or damaged by the short circuit.
4. After servicing, see to it that all the protective devices such as insulation barriers, insulation papers shields are properly installed.
5. After servicing, make the following leakage current checks to prevent the customer from being exposed to shock hazards.

1.2 Leakage Current Cold Check

1. Unplug the AC cord and connect a jumper between the two prongs on the plug.
2. Measure the resistance value, with an ohmmeter, between the jumpered AC plug and each exposed metallic cabinet part on the equipment such as screwheads, connectors, control shafts, etc. When the exposed metallic part has a return path to the chassis, the reading should be between $1M\Omega$ and $5.2M\Omega$. When the exposed metal does not have a return path to the chassis, the reading must be infinity.

1.3 Leakage Current Hot Check (See Figure 1)

1. Plug the AC cord directly into the AC outlet. Do not use an isolation transformer for this check.
2. Connect a $1.5k\Omega$, 10 W resistor, in parallel with a $0.15\mu F$ capacitor, between each exposed metallic part on the set and a good earth ground, as shown in [Figure 1](#).
3. Use an AC voltmeter, with $1k\Omega/V$ or more sensitivity, to measure the potential across the resistor.
4. Check each exposed metallic part, and measure the voltage at each point.
5. Reverse the AC plug in the AC outlet and repeat each of the above measurements.
6. The potential at any point should not exceed 0.75 V RMS.

A leakage current tester (Simpson Model 229 or equivalent) may be used to make the hot checks, leakage current must not exceed 1/2 mA. In case a measurement is outside of the limits specified, there is a possibility of a shock hazard, and the equipment should be repaired and rechecked before it is returned to the customer.

Figure 1

Hot-Check Circuit

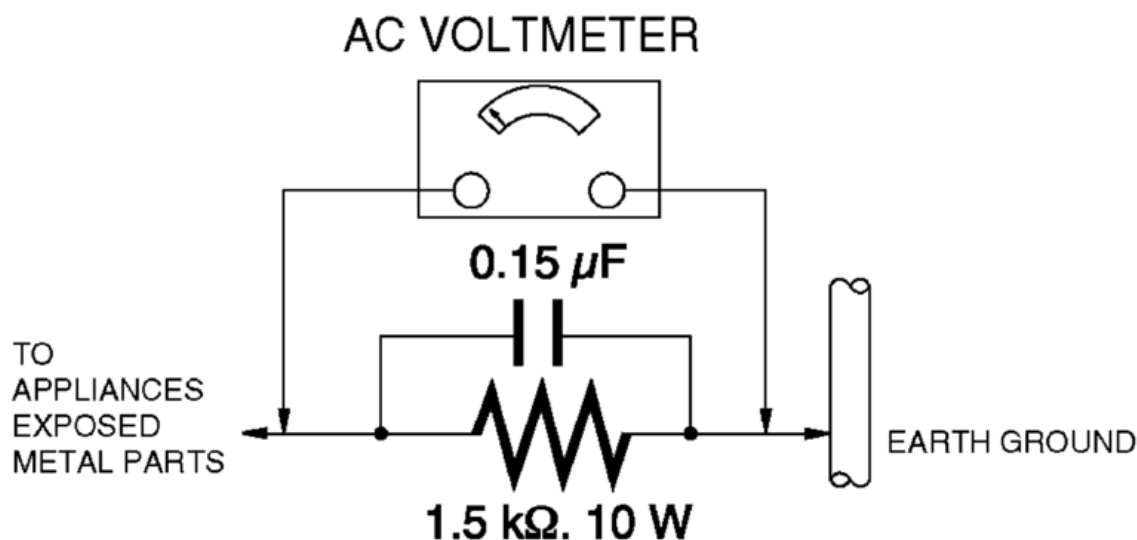

1.4 How to Discharge the Capacitor on Top P.C.B. Unit

CAUTION:

1. Be sure to discharge the capacitor on Top P.C.B. Unit.
2. Be careful of the high voltage circuit on Top P.C.B. Unit when servicing.

[Discharging Procedure]

1. Refer to the disassemble procedure and remove the necessary parts/unit.
2. Install the insulation tube onto the lead part of Resistor (ERG5SJ102:1k Ω /5W).
(an equivalent type of resistor may be used.)
3. Place a resistor between both terminals of capacitor on the Top P.C.B. Unit for approx. 5 seconds.
4. After discharging, confirm that the capacitor voltage is lower than 10V using a voltmeter.

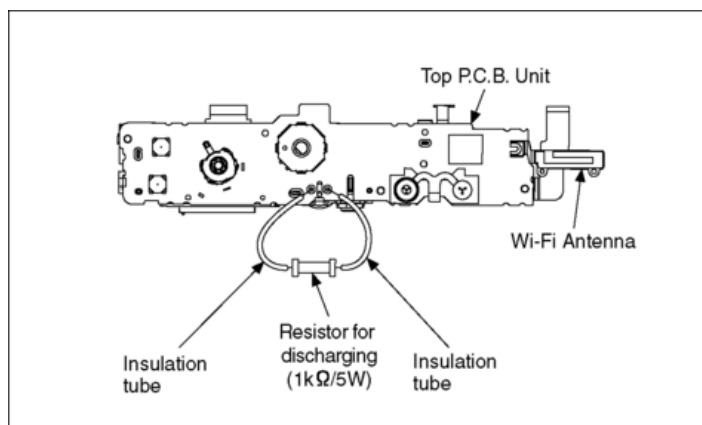

Fig. F1

3 Service Navigation

3.1 Introduction

This service manual contains technical information, which will allow service personnel's to understand and service this model.

Please place orders using the parts list and not the drawing reference numbers.

If the circuit is changed or modified, the information will be followed by service manual to be controlled with original service manual.

3.2 Important Notice

3.2.1 About lens block

The image sensor (MOS) unit which are connected to the lens unit with 3 screws. 2 of these 3 screws are locked, after performing the Optical tilt adjustment. During servicing, if one of MOS fixing screws are loosened, the Optical tilt adjustment must be performed. (About the Optical tilt adjustment, refer to the "10.3.2 [Adjustment Specifications](#)" for details.)

- Using the Extension cable, perform the Optical tilt adjustment according to the following procedure.
 1. Remove the Frame Plate Unit. (Refer to Disassembly Procedures.)
 2. Remove the Speaker from the Frame.

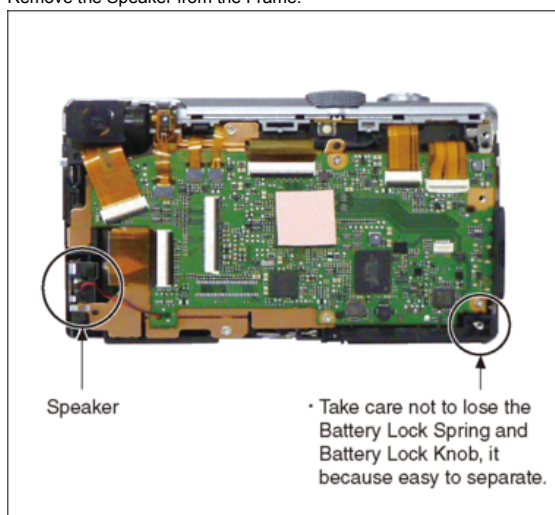

3. Using the Rear Operation FPC, connect the Main P.C.B. to Rear Operation P.C.B. Unit.
4. Using the Extension cable, connect the Main P.C.B. to LCD Unit.

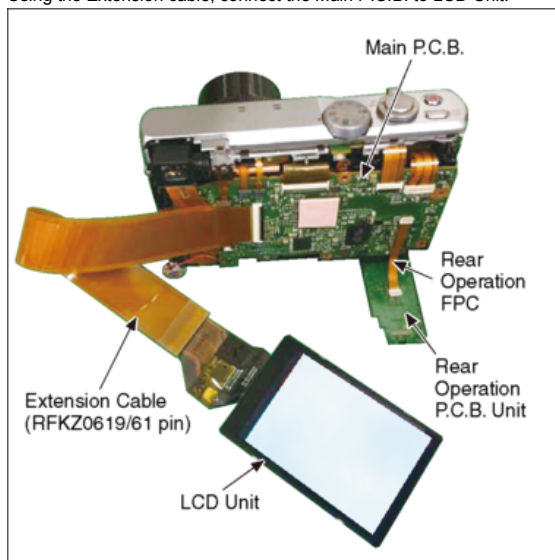

5. Using the Extension cable, connect the Main P.C.B. to Lens Unit Flex.
6. Insulation Sheet is inserted between the LCD Unit, Rear Operation P.C.B. Unit and the Main P.C.B.

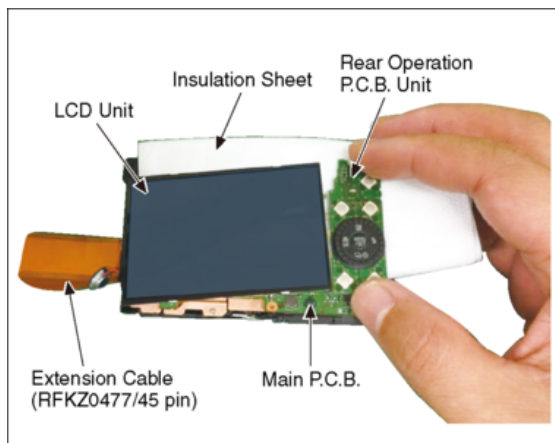

7. The Main P.C.B. is lifted, perform the Optical tilt adjustment.

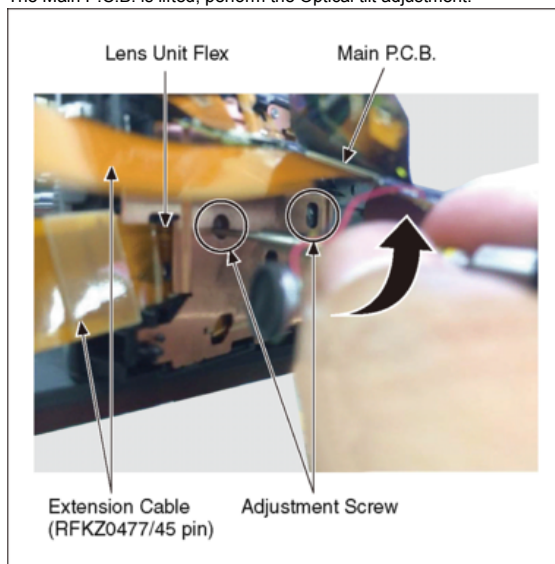

3.2.2 About VENUS ENGINE (IC6001) < Located on the Main P.C.B. >

- The VENUS ENGINE (IC6001) consists of two IC chips, which are fixed together with solder. (It is so called, "P_a_c_k_a_g_e_Q_n_P_a_c_k_a_g_e" type of IC.)

Caution:

- During servicing, do not press down hard on the surface of IC6001.

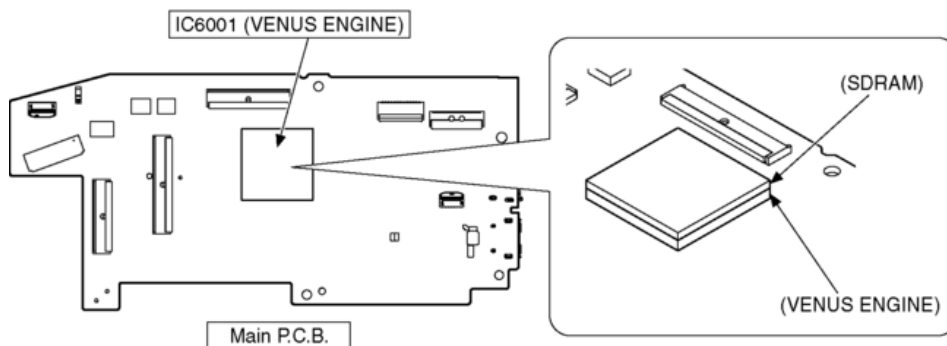

3.2.3 About Flash ROM (IC6003) and Charging Control Microcomputer (IC1502)

When the Flash Rom or Charging Control Microcomputer is replaced, it is need to adjust the firmware of the Charging Control Microcomputer to the one of the Flash ROM. For details, refer to "10.3.2. [Adjustment Specifications](#)".

It may takes about 10 seconds. While doing the adjustment, don't turn the power off forcibly. (It cause the Charging Control Microcomputer crush, then the camera can not turn on.)

3.2.4 About Flexible Cable and Connector

Do not touch carelessly so that the foreign body should not adhere to the terminal part of flexible cable and connector. Wipe off with a clean cloth and the cotton bud, etc. when the terminal part is dirty.

3.3 Service Notes

3.3.1 About Wi-Fi Function

The page number in this chapter does not show the page number of this service manual.

● Operating the camera by connecting it to a smartphone

You can easily set up a direct connection to your smartphone without entering a password.

- Taking pictures via a smartphone (→47)
- Playing back pictures in the camera on a smartphone (→47)
- Saving pictures in the camera to a smartphone
- Sending pictures in the camera to social networking services
- Adding location information to pictures in the camera from a smartphone
- Combining motion pictures recorded with Snap Movie according to your preference on a smartphone

● Displaying still pictures on a TV

● Wireless printing

● Sending pictures to AV device

● Sending pictures to a PC

● Using WEB services

3.3.2 Important Notice of Servicing

This Camera unit has the personal information of wireless LAN connection the customer has registered.

For the protection of private information, please erase the personal information after the completion of repair by "INITIAL SETTING".

In addition, please print out the following documents, and pass to the customer with the Camera unit.

Printing Material [Leaflet for Customer]



3.4 General Description About Lead Free Solder (PbF)

The lead free solder has been used in the mounting process of all electrical components on the printed circuit boards used for this equipment in considering the globally environmental conservation.

The normal solder is the alloy of tin (Sn) and lead (Pb). On the other hand, the lead free solder is the alloy mainly consists of tin (Sn), silver (Ag) and Copper (Cu), and the melting point of the lead free solder is higher approx.30 °C (86 °F) more than that of the normal solder.

Definition of PCB Lead Free Solder being used

The letter of **PbF** is printed either foil side or components side on the P.C.B. using the lead free solder.

(See right figure)

PbF

Service caution for repair work using Lead Free Solder (PbF)

- The lead free solder has to be used when repairing the equipment for which the lead free solder is used.
(Definition: The letter of **PbF** is printed on the P.C.B. using the lead free solder.)
- To put lead free solder, it should be well molten and mixed with the original lead free solder.
- Remove the remaining lead free solder on the P.C.B. cleanly for soldering of the new IC.
- Since the melting point of the lead free solder is higher than that of the normal lead solder, it takes the longer time to melt the lead free solder.
- Use the soldering iron (more than 70W) equipped with the temperature control after setting the temperature at 350±30 °C (662±86 °F).

Recommended Lead Free Solder (Service Parts Route.)

- The following 3 types of lead free solder are available through the service parts route.
 - SVKZ000001----- (0.3mm 100g Reel)
 - SVKZ000002----- (0.6mm 100g Reel)
 - SVKZ000003----- (1.0mm 100g Reel)

Note:

* Ingredient: Tin (Sn) 96.5%, Silver (Ag) 3.0%, Copper (Cu) 0.5%. (Flex cored)

3.5 How to Define the Model Suffix (NTSC or PAL model)

There are six kinds of DMC-TZ80/TZ81/ZS60, regardless of the colours.

- a) DMC-TZ85 (Japan domestic model.)
- b) DMC-ZS60P/PP
- c) DMC-TZ80EB/EF/EG/EP, TZ81EG
- d) DMC-TZ80EE
- e) DMC-TZ80GN
- f) DMC-TZ80GA/GC, ZS60GH

What is the difference is that the "INITIAL SETTINGS" data which is stored in Flash ROM mounted on Main P.C.B.

3.5.1 Defining methods

To define the model suffix to be serviced, refer to the nameplate which is putted on the bottom side of the Unit.

a) DMC-TZ85 (Japan domestic model)

The nameplate for this model shows the following Safety registration mark.

**b) DMC-ZS60P/PP**

The nameplate for these models shows the following Safety registration mark.

**c) DMC-TZ80EB/EF/EG/EP, TZ81EG**

The nameplate for these models shows the following Safety registration mark.

**d) DMC-TZ80EE**

The nameplate for this model shows the following Safety registration mark.

**e) DMC-TZ80GN**

The nameplate for this model shows the following Safety registration mark.

**f) DMC-TZ80GA/GC, DMC-ZS60GH**

The nameplate for these models does not show any above Safety registration mark.

Note:

After replacing the Main P.C.B., be sure to achieve adjustment.

3.5.2 INITIAL SETTINGS:

After replacing the Main P.C.B. and/or Flash-ROM, make sure to perform the initial settings after achieving the adjustment by ordering the following procedure in accordance with model suffix of the unit.

1. IMPORTANT NOTICE:

Before proceeding Initial settings, be sure to read the following CAUTION.

CAUTION :(INITIAL SETTINGS)

--- AFTER REPLACING THE MAIN P.C.B. and/or FLASH-ROM ---

[Except "DMC-TZ80EG/EF/EB/EP and TZ81" models]

- *. The model suffix can be chosen **JUST ONE TIME**.
(Effective model suffix : DMC-TZ80 "EE/GA/GC and GN", DMC-ZS60 "P/PP and GH" and "NONE(JAPAN)")
- *. Once one of the model suffix has been chosen, the model suffix lists will not be displayed, thus, it can not be changed.

2. PROCEDURES:

- Precautions: Read the above "CAUTION" carefully.
- Preparation:
 1. Attach the fully charged Battery.
 2. Set the mode dial to the **PROGRAM AE** mode.
* If the mode dial position is other than **PROGRAM AE** mode, it does not display the initial settings menu.
- **Step 1. The temporary cancellation of "INITIAL SETTINGS":**
While keep pressing "**RIGHT**" of Cursor button", **MENU/SET** button and **DISPLAY** button simultaneously, turn the Power on.
- **Step 2. The cancellation of "INITIAL SETTINGS":**
Press **PLAYBACK** button to switch to the playback screen. (Keep pressing the button.)
Press "**UP**" of Cursor button" additionally, then turn the Power off.
The LCD displays the " ! " mark before the unit powers down.

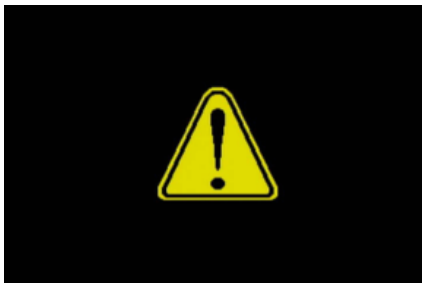

• **Step 3. Turn the Power on:**

Turn the Power on.

• **Step 4. Display the "INITIAL SETTINGS" menu:**

* If the unit is other than [PROGRAM AE] mode, it does not display the initial settings menu.

While keep pressing [MENU/SET] and "RIGHT" of Cursor button simultaneously, turn the Power off.

The "INITIAL SETTINGS" menu is displayed.

There are two kinds of "INITIAL SETTINGS" menu form as follows:

[CASE 1. After replacing MAIN P.C.B.]

There are three kinds of menu from as follows:

[Except for "DMC-TZ80EG, EF, EB, EP and TZ81EG" models : (SEP0684AC is used as a Main P.C.B.)]

When Main P.C.B. has just been replaced, all of the model suffix are displayed as follows. (Three pages in total)

<p>(No existent model) → TZ80</p> <p>DMC-ZS60P → ZS60</p> <p>DMC-ZS60PP → ZS60</p> <p>DMC-TZ80GC → TZ80</p>			<p>DMC-TZ80EE</p> <p>DMC-TZ80GN</p> <p>DMC-ZS60GH</p> <p>DMC-TZ80GA</p>
<p>DMC-TZ85 (Japan domestic model) → TZ85</p>			

[Only for "DMC-TZ80EG, EF, EB, EP and TZ81" models : (SEP0684AD is used as a Main P.C.B.)]

When Main P.C.B. has just been replaced, only 5 model suffix are displayed as follows. (Two pages in total)

	DMC-TZ80 Models	DMC-TZ81 Models	
<p>DMC-TZ80EG (No "E" model) → TZ80</p> <p>(No "GC" model) → TZ80</p> <p>DMC-TZ80EF → TZ80</p> <p>DMC-TZ80EB → TZ80</p>			<p>DMC-TZ81EG (No "E" model)</p> <p>(No "GC" model)</p> <p>(No "EF" model)</p> <p>(No "EB" model)</p>
<p>DMC-TZ80EP → TZ80</p>			<p>(No "EP" model)</p>

To display the "TZ81" model suffix, press the [DELETE] button.

[CASE 2. Other than "After replacing Main P.C.B."]

< Other than "EG/EF/EB and EP" models >



< Only "EG/EF/EB and EP" models >

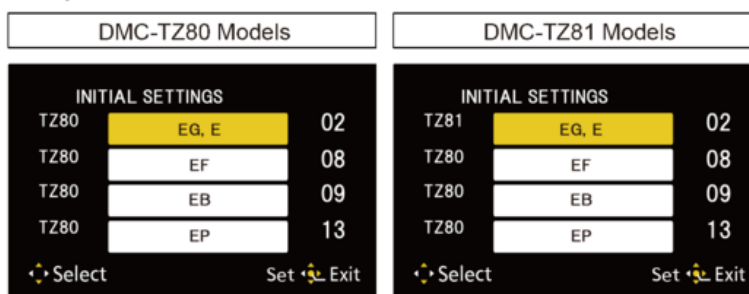

To display the "TZ81" model suffix, press the **DELETE** button.

- **Step 5. The cancellation of "STRICT MODE":**

Press **DISPLAY** button, then [Strict] in the upper right corner of the LCD display will disappear.

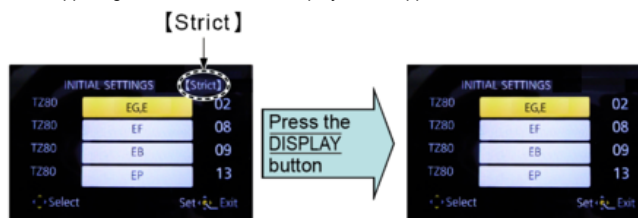

- **Step 6. Chose the model suffix in "INITIAL SETTINGS": (Refer to "CAUTION")**

[Caution: After replacing Main P.C.B.]

(Especially, other than "DMC-TZ80EG/EF/EB/EP and DMC-TZ81" models)

The model suffix can be chosen, JUST ONE TIME.

Once one of the model suffix have been chosen, the model suffix lists will not be displayed, thus, it can not be changed.

Therefore, select the area carefully.

Select the area with pressing "**UP**" / "**DOWN**" of Cursor buttons".

- **Step 7. Set the model suffix at "INITIAL SETTINGS":**

Press the "**RIGHT**" of Cursor buttons".

The only set area is displayed. Press the "**RIGHT**" of Cursor buttons" after confirmation.

(The unit is powered off automatically.)



Note:

It may cause the following error indication without cancellation of "STRICT MODE".

In this case, press **DISPLAY** button after disappearing error indication.

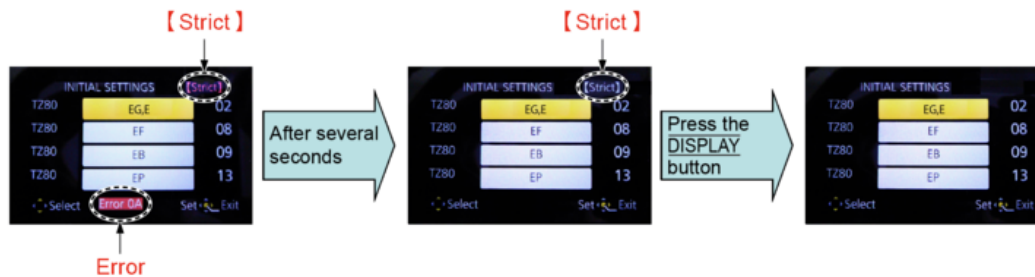

- **Step 8. CONFIRMATION:**

Confirm the display of "PLEASE SET THE CLOCK" in concerned language when the unit is turned on again.
When the unit is connected to PC with USB cable, it is detected as removable media.

1) As for your reference, major default setting condition is as shown in the following table.

- **Default setting (After "INITIAL SETTINGS")**

	MODEL	VIDEO OUTPUT	LANGUAGE	DATE	REMARKS
a)	DMC-TZ85 (Japan domestic model)	NTSC	Japanese	Year/Month/Date	
b)	DMC-TZ80EB	PAL	English	Date/Month/Year	
c)	DMC-TZ80EE	PAL	Russian	Date/Month/Year	
d)	DMC-TZ80EF	PAL	English	Date/Month/Year	
e)	DMC-TZ80EG	PAL	English	Date/Month/Year	
f)	DMC-TZ80EP	PAL	English	Date/Month/Year	
g)	DMC-TZ80GA	PAL	English	Date/Month/Year	
h)	DMC-TZ80GC	PAL	English	Date/Month/Year	
i)	DMC-TZ80GN	PAL	English	Date/Month/Year	
j)	DMC-TZ81EG	PAL	English	Date/Month/Year	
k)	DMC-ZS60P	NTSC	English	Month/Date/Year	
l)	DMC-ZS60PP	NTSC	English	Month/Date/Year	
m)	DMC-ZS60GH	PAL	English	Date/Month/Year	

4 Specifications

The following specification is for DMC-ZS60P/PP, ZS100P/PP.
Some specifications may differ depending on model suffix.

Digital Camera: Information for your safety

Power Source	DC 8.4 V (=== 8.4 V)
Power Consumption	<p>ZS100</p> <p>2.3 W (When recording with monitor) 2.7 W (When recording with viewfinder) 1.5 W (When playing back with monitor) 1.5 W (When playing back with viewfinder)</p> <p>ZS60</p> <p>2.2 W (When recording with monitor) 2.6 W (When recording with viewfinder) 1.5 W (When playing back with monitor) 1.5 W (When playing back with viewfinder)</p>

Camera effective pixels	<p>ZS100</p> <p>20,100,000 pixels</p> <p>ZS60</p> <p>18,100,000 pixels</p>
Image sensor	<p>ZS100</p> <p>1" MOS sensor, total pixel number 20,900,000 pixels Primary color filter</p> <p>ZS60</p> <p>1/2.3" MOS sensor, total pixel number 18,900,000 pixels Primary color filter</p>

Lens	<p>ZS100 Optical 10x zoom f=9.1 mm to 91 mm (35 mm film camera equivalent: 25 mm to 250 mm) Max. Wide: F2.8 to F8.0 Max. Tele: F5.9 to F8.0</p> <p>ZS60 Optical 30x zoom f=4.3 mm to 129 mm (35 mm film camera equivalent: 24 mm to 720 mm) Max. Wide: F3.3 to F8.0 Max. Tele: F6.4 to F8.0</p>
Image Stabilizer	Optical method
Focus range	<p>ZS100 AF: 50 cm (1.6 feet) (Max. Wide)/ 70 cm (2.3 feet) (Max. Tele) to ∞ AF Macro/MF/Intelligent Auto/Motion picture: 5 cm (0.16 feet) (Max. Wide)/ 70 cm (2.3 feet) (Max. Tele) to ∞</p> <p>ZS60 AF: 50 cm (1.6 feet) (Max. Wide)/ 2 m (6.6 feet) (Max. Tele) to ∞ AF Macro/MF/Intelligent Auto/Motion picture: 3 cm (0.098 feet) (Max. Wide)/ 2 m (6.6 feet) (Max. Tele) to ∞</p>
Shutter system	Electronic shutter + Mechanical shutter

Minimum Illumination	<p>ZS100 Approx. 9 lx (when i-Low light is used, the shutter speed is 1/30th of a second)</p> <p>ZS60 Approx. 10 lx (when i-Low light is used, the shutter speed is 1/30th of a second)</p>
Shutter speed	<p>ZS100 Still picture: T (Time) (Max. approx. 120 seconds), 60 seconds to 1/2000th of a second (When the mechanical shutter is used), 1 second to 1/16000th of a second (When the electronic shutter is used) Motion picture: 1/25th of a second to 1/16000th of a second (When [FHD/24M/24p] is set in [AVCHD], or [4K/100M/24p] is set in [MP4]), 1/2 second to 1/16000th of a second (When [M] is selected in Creative Video Mode, MF), 1/30th of a second to 1/16000th of a second (Other than the above)</p> <p>ZS60 Still picture: 60 seconds to 1/2000th of a second (When the mechanical shutter is used and [Artistic Nightscape] is selected as the Scene Guide Mode), 4 seconds to 1/2000th of a second (When the mechanical shutter is used, in cases other than the above), 1 second to 1/16000th of a second (When the electronic shutter is used) Motion picture: 1/2 second to 1/16000th of a second (When [M] is selected in Creative Video Mode, MF), 1/30th of a second to 1/16000th of a second (Other than the above)</p>

Exposure (AE)	Program AE (P)/Aperture-priority AE (A)/ Shutter-priority AE (S)/Manual exposure (M)/AUTO Exposure Compensation (1/3 EV steps, -5 EV to +5 EV)
[Metering Mode]	Multiple/Center weighted/Spot
Monitor	3.0" TFT LCD (3:2) (Approx. 1,040,000 dots) (field of view ratio about 100%) Touch screen
Viewfinder	0.2" Color LCD Live Viewfinder (4:3) (Approx. 1,160,000 dots equivalent) (field of view ratio about 100%) [Magnification approx. 2.59x, 0.46x (35 mm film camera equivalent), with 50 mm lens at infinity; -1.0 m ⁻¹] (with diopter adjustment -4.0 to +4.0 diopter)
Flash	ZS100 ZS60 Built-in pop up flash Built-in flash AUTO, AUTO/Red-Eye Reduction, Forced ON, Forced ON/Red-Eye Reduction, Slow Sync., Slow Sync./Red-Eye Reduction, Forced OFF
Microphones	Stereo
Speaker	Monaural
Recording media	SD Memory Card/SDHC Memory Card*/ SDXC Memory Card* * UHS-I UHS Speed Class 3
Recording file format	
Still picture	RAW/JPEG (based on Design rule for Camera File system, based on Exif 2.3 standard/DPOF corresponding)
Motion picture	AVCHD Progressive/AVCHD/MP4
Audio compression format	AVCHD: Dolby® Digital (2 ch) MP4: AAC (2 ch)
Interface	
Digital	USB 2.0 (High Speed)
Terminal	
[HDMI]	Micro HDMI Type D
[CHARGE]	USB 2.0 micro-B
Dimensions	ZS100 Approx. 110.5 mm (W) x 64.5 mm (H) x 44.3 mm (D) [4.35" (W) x 2.54" (H) x 1.74" (D)] (excluding the projection part) ZS60 Approx. 112.0 mm (W) x 64.0 mm (H) x 38.0 mm (D) [4.41" (W) x 2.52" (H) x 1.50" (D)] (excluding the projection part)
Mass (weight)	ZS100 With card and battery: Approx. 310 g (0.68 lb) Excluding card and battery: Approx. 268 g (0.59 lb) ZS60 With card and battery: Approx. 282 g (0.62 lb) Excluding card and battery: Approx. 240 g (0.53 lb)
Operating temperature	0 °C to 40 °C (32 °F to 104 °F)
Operating humidity	10%RH to 80%RH
Language select	[ENGLISH] / [DEUTSCH] / [FRANÇAIS] / [ESPAÑOL] / [PORTUGUÉS] / [ITALIANO] / [繁體中文] / [日本語]

■ Wi-Fi

Compliance standard	IEEE 802.11b/g/n (standard wireless LAN protocol)
Frequency range used (central frequency)	2412 MHz to 2462 MHz (1 to 11 ch)
Encryption method	Wi-Fi compliant WPA™/WPA2™
Access method	Infrastructure mode

■ AC adaptor

(Panasonic SAE0012A): Information for your safety

Input:	110 V – 240 V ~ 50/60 Hz 0.2 A
Output:	5 V = 1.0 A

■ Battery Pack (lithium-ion)

(Panasonic DMW-BLG10PP): Information for your safety

Voltage/capacity:	7.2 V/1025 mAh
-------------------	----------------

The symbols on this product (including the accessories) represent the following:

~	AC
=	DC
□	Class II equipment (The construction of the product is double-insulated.)

Specifications are subject to change without notice.

5 Location of Controls and Components

The following description is for DMC-ZS60P/PP, ZS100P/PP.

Some description may differ depending on model suffix.

The page number in this chapter does not show the page number of this service manual.

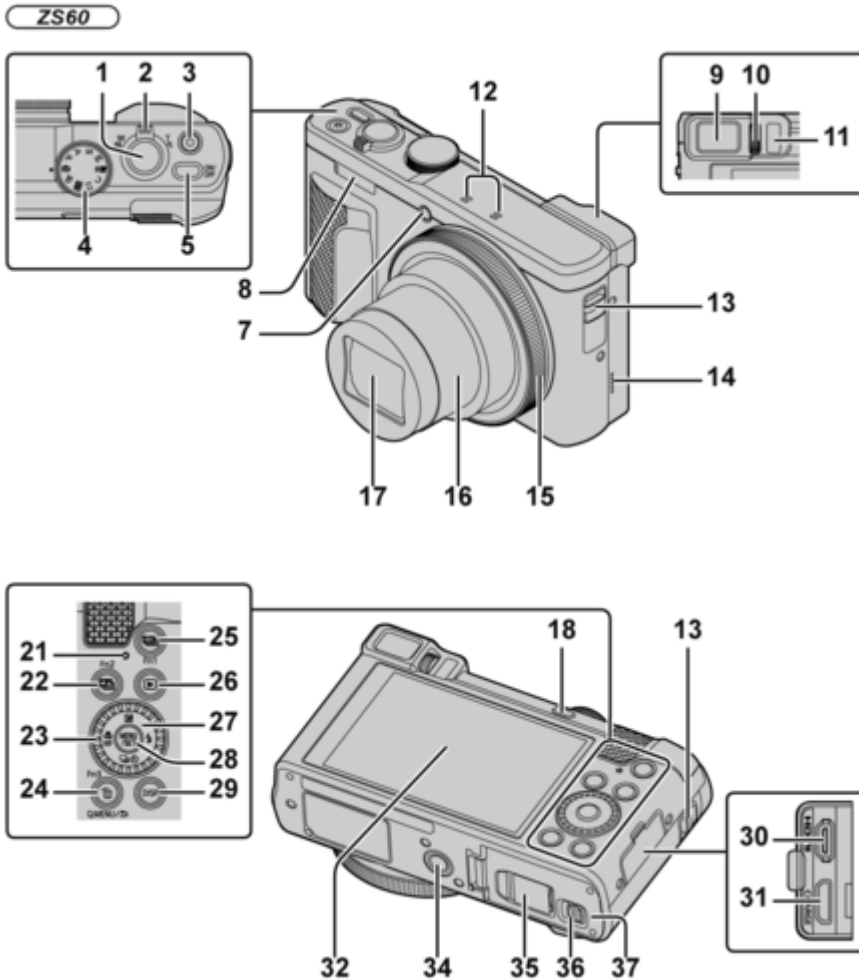

- 1 Shutter button (→22)
- 2 Zoom lever (→21)
- 3 Motion picture button (→37)
- 4 Mode dial (→23)
- 5 **ZS100**
Camera [ON/OFF] switch
ZS60
Camera [ON/OFF] button
- 6 **ZS100**
Rear dial (→26)
- 7 Self-timer indicator/AF assist lamp
- 8 Flash
- 9 Viewfinder (→25, 52)
- 10 Diopter adjustment dial
- 11 Eye sensor (→25)
- 12 Stereo microphone
- 13 Strap eyelet

- To prevent dropping, be sure to attach the supplied strap and fit it to your wrist.
- 14 **ZS60**
Speaker
- 15 Control ring (→26)
- 16 Lens barrel
- 17 Lens
- 18 [LVF] button (→25)/[Fn4] button
- 19 **ZS100**
Flash open lever
- 20 **ZS100**
[AF/AE LOCK] button
 - You can take pictures by locking the focus and/or exposure.
- 21 Charging lamp (→18)/
Wi-Fi[®] connection lamp
- 22 **ZS100** ([Post Focus]) button (→33)/
[Fn2] button
- 23 **ZS60**
Control dial (→26)
- 24 [Q.MENU/↵] (Cancel) button/
[] (Delete) button (→41)/
[Fn3] button
 - You can easily call some of the menu items and set them during recording.
- 25 **ZS100** (4K photo mode) button (→30)/
[Fn1] button
- 26 [] (Playback) button (→41)
- 27 Cursor button (→24)
- 28 [MENU/SET] button
- 29 [DISP.] button
 - Use this to change display.
- 30 [HDMI] socket
- 31 [CHARGE] socket (→18)
- 32 Touch screen (→27)/monitor (→52)
- 33 **ZS100**
Speaker
- 34 Tripod mount
 - Do not attach this unit to tripods that have screws with a length of 5.5 mm (0.22 inch) or more. Doing so may damage this unit or the unit may not be secured properly on the tripod.
- 35 DC coupler cover (→67)
- 36 Release lever (→17)
- 37 Card/Battery door (→17)

5 Location of Controls and Components

The following description is for DMC-ZS60P/PP, ZS100P/PP.

Some description may differ depending on model suffix.

The page number in this chapter does not show the page number of this service manual.

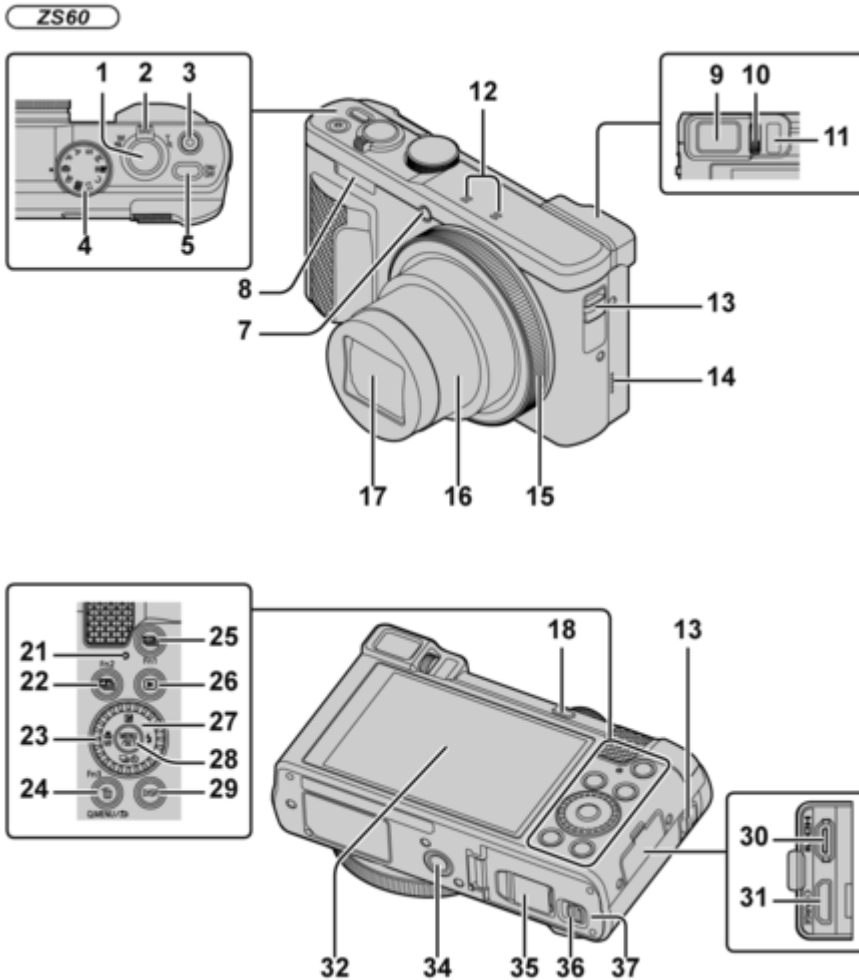

- 1 Shutter button (→22)
- 2 Zoom lever (→21)
- 3 Motion picture button (→37)
- 4 Mode dial (→23)
- 5 **ZS100**
Camera [ON/OFF] switch
ZS60
Camera [ON/OFF] button
- 6 **ZS100**
Rear dial (→26)
- 7 Self-timer indicator/AF assist lamp
- 8 Flash
- 9 Viewfinder (→25, 52)
- 10 Diopter adjustment dial
- 11 Eye sensor (→25)
- 12 Stereo microphone
- 13 Strap eyelet

- To prevent dropping, be sure to attach the supplied strap and fit it to your wrist.
- 14 **ZS60**
Speaker
- 15 Control ring (→26)
- 16 Lens barrel
- 17 Lens
- 18 [LVF] button (→25)/[Fn4] button
- 19 **ZS100**
Flash open lever
- 20 **ZS100**
[AF/AE LOCK] button
 - You can take pictures by locking the focus and/or exposure.
- 21 Charging lamp (→18)/
Wi-Fi[®] connection lamp
- 22 **ZS100** ([Post Focus]) button (→33)/
[Fn2] button
- 23 **ZS60**
Control dial (→26)
- 24 [Q.MENU/↵] (Cancel) button/
[] (Delete) button (→41)/
[Fn3] button
 - You can easily call some of the menu items and set them during recording.
- 25 **ZS100** (4K photo mode) button (→30)/
[Fn1] button
- 26 [] (Playback) button (→41)
- 27 Cursor button (→24)
- 28 [MENU/SET] button
- 29 [DISP.] button
 - Use this to change display.
- 30 [HDMI] socket
- 31 [CHARGE] socket (→18)
- 32 Touch screen (→27)/monitor (→52)
- 33 **ZS100**
Speaker
- 34 Tripod mount
 - Do not attach this unit to tripods that have screws with a length of 5.5 mm (0.22 inch) or more. Doing so may damage this unit or the unit may not be secured properly on the tripod.
- 35 DC coupler cover (→67)
- 36 Release lever (→17)
- 37 Card/Battery door (→17)

6 Service Mode

6.1 Error Code Memory Function

1. General description

This unit is equipped with history of error code memory function, and can be memorized 16 error codes in sequence from the latest. When the error is occurred more than 16, the oldest error is overwritten in sequence.

The error code is not memorized when the power supply is shut down forcibly (i.e., when the unit is powered on by the battery, the battery is pulled out) The error code is memorized to Flash ROM when the unit has just before powered off.

2. How to display

The error code can be displayed by ordering the following procedure:

Preparation:

1. Attach the fully charged Battery, and insert the memory card (32MB or more).
2. Set the mode dial to the PROGRAM AE mode.

Note:

*Since this unit has built-in memory, it can be performed without inserting Memory Card.

Step 1. The temporary cancellation of "INITIAL SETTINGS":

While keep pressing "RIGHT" of Cursor button, MENU/SET button and DISPLAY button simultaneously, turn the Power on.

Step 2. Execute the error code display mode:

Press the "PLAYBACK" button, "LEFT" of Cursor button and MENU/SET button simultaneously.

The display is changed as shown below when the above buttons are pressed simultaneously.

Normal display → Error code display → CAMERA INFO → Normal display →

Example of Error Code Display

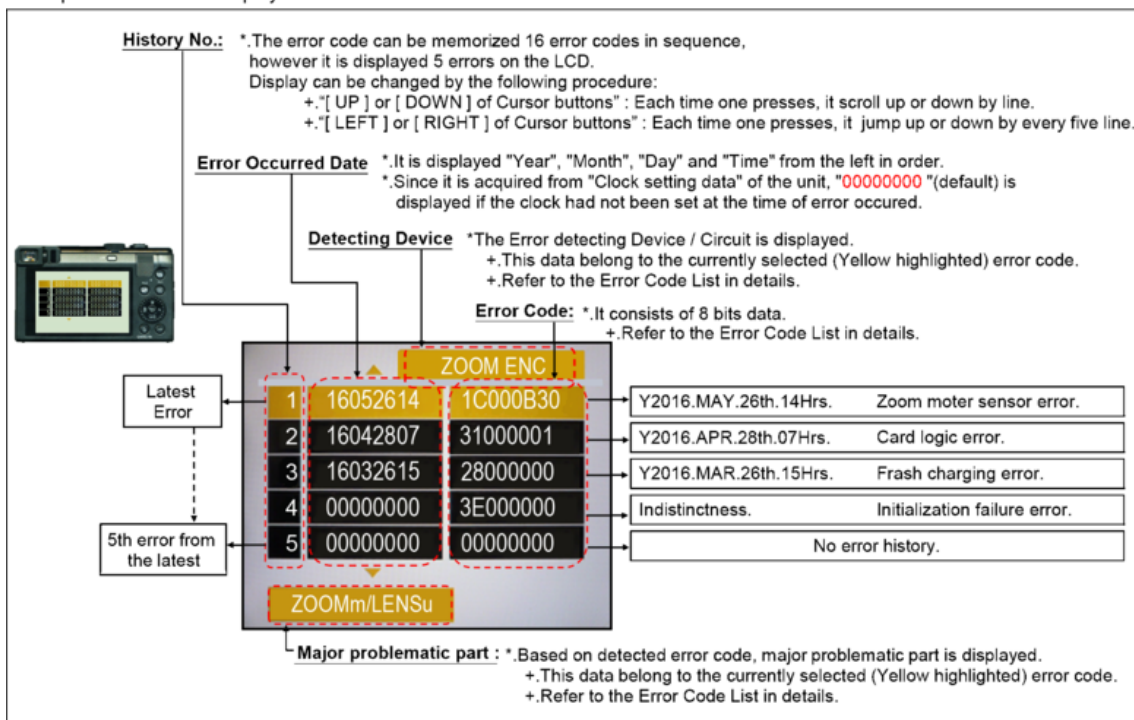

3. Error Code List

The error code consists of 8 bits data and it shows the following information.

Attribute	Main item	Sub item	Error code		Contents (Upper)		Error Indication	
			High 4 bits	Low 4 bits	Check point (Lower)		Detecting device	Part/Circuit
LENS	Lens drive	Focus	1C*0	0?01	HP High detect error (Focus encoder always detects High, and not becomes Low) Mechanical lock, FP9004-(43) signal line or IC6001 (VENUS ENGINE)		FOCUS L	LENS FPC/DSP
				0?02	HP Low detect error (Focus encoder always detects Low, and not becomes High) Mechanical lock, FP9004-(43) signal line or IC6001 (VENUS ENGINE)			
		Zoom	0?10	Collapsible barrel Low detect error (Collapsible barrel encoder always detects High.) Mechanical lock, FP9004-(43) signal line or IC6001 (VENUS ENGINE)		ZOOM L	ZOOMm/LENSu	

				ENGINE)		
			0720	Collapsible barrel High detect error (Collapsible barrel encoder always detects Low.) Mechanical lock, FP9004-(43) signal line or IC6001 (VENUS ENGINE)	ZOOM H	
			0730	Zoom motor sensor error. (Initialized or Terminated) Mechanical lock, FP9004-(4) signal line or IC6001 (VENUS ENGINE)	ZOOM ENC	
			0740	Zoom motor sensor error. (During monitor mode.) Mechanical lock, FP9004-(4) signal line or IC6001 (VENUS ENGINE)		
			0750	Zoom motor sensor error. (During monitor mode with slow speed.) Mechanical lock, FP9004-(4) signal line or IC6001 (VENUS ENGINE)		
			0760	Detection of zoom misregistration by impact such as falls. Lens Unit	(No indication)	(No indication)
		OIS	1000	PSD (X) error. Hall element (X axis) position detect error in OIS unit. OIS Unit	OIS X	LENSu NG
			2000	PSD (Y) error. Hall element (Y axis) position detect error in OIS unit. OIS Unit	OIS Y	
			3000	GYRO (X) error. Gyro (IC7101 : X axis) detect error on Main P.C.B. IC7101 (Gyro element) or IC6001 (VENUS ENGINE)	GYRO X	GYRO NG
			4000	GYRO (Y) error. Gyro (IC7101 : Y axis) detect error on Main P.C.B. IC7101 (Gyro element) or IC6001 (VENUS ENGINE)	GYRO Y	
			5000	GYRO (R) error. Gyro (IC7101 : R axis) detect error on Main P.C.B. IC7101 (Gyro element) or IC6001 (VENUS ENGINE)	GYRO R	
			6000	Drive voltage (X) error. LENS Unit, LENS flex breaks, IC6001(VENUS ENGINE) AD value error, etc.	OISX REF	LENSu/LENS FPC
			7000	Drive voltage (Y) error. LENS Unit, LENS flex breaks, IC6001(VENUS ENGINE) AD value error, etc.	OISY REF	
			8000	OIS GYRO - Digital communication error. IC7101 (Gyro element) or IC6001 (VENUS ENGINE)	(No indication)	(No indication)
		Lens	18*1	0000 Power ON time out error. Lens drive system	LENS DRV	LENSu
			18*2	0000 Power OFF time out error. Lens drive system		
	Adj.History	OIS	1D*0	2000 OIS adj. Yaw direction amplitude error (small) 3000 OIS adj. Pitch direction amplitude error (small) 4000 OIS adj. Yaw direction amplitude error (large) 5000 OIS adj. Pitch direction amplitude error (large) 8000 OIS adj. Yaw direction off set error 9000 OIS adj. Pitch direction off set error A000 OIS adj. Yaw direction gain error B000 OIS adj. Pitch direction gain error C000 OIS adj. Yaw direction position sensor error D000 OIS adj. Pitch direction position sensor error E000 OIS adj. other error	OIS ADJ	OIS ADJ
HARD	FLASH	Flash	28*0	0000 Flash charging capacitor did not been fully charged within 20 seconds	STRB CHG	TOP P.C.B./FPC
	FLASH ROM	Data Area	2B*0	0001 IC6003 (Flash-ROM) data reading error is detected when the unit turns ON 0002 IC6003 (Flash-ROM) data writing error is detected when the unit turns OFF	FROM RE FROM WR	FROM FROM
		Program Area		0005 Firmware update error of IC9101 0006 Firmware update error of IC1502	(No indication)	(No indication)
SOFT	CPU	Reset	30*0	0001 System error (NMI reset) 0007	NMI RST	MAIN P.C.B.
	Recording Media	Memory card	31*0	0002 Memory card physical error During formatting the memory card, there is no response from the memory card If the mini-SD memory card is used, check the SD memory card adaptor 0004 Memory card writing error Check the memory card. It might be damage one.	SD CARD SD WRITE	SD CARD/DSP
	Operation	Power on	3B*0	0000 Flash ROM processing early period of camera during movement.	INIT	(No indication)
	Zoom	Zoom	3C*0	0000 Imperfect zoom lens processing Zoom lens	ZOOM	ZOOMm/LENSu
	Recording	Motion Image Recording	3F*0	0001 File time out error in recording motion image 0002 File data cue send error in recording motion image	(No indication)	(No indication)
Wi-Fi			3211	**02 Wi-Fi related errors:		

			*Generally, above are unable to specified the, which cannot be used for malfunction diagnosis.
	**0C		

Important notice about "Error Code List"**1) About "" indication:**

The third digit from the left is different as follows.

+ .In case of 0 (example: 18 001000)

When the third digit from the left shows "0", this error occurred under the condition of INITIAL SETTINGS has been completed.

It means that this error is occurred basically at user side.

+ .In case of 8 (example: 18 801000)

When the third digit from the left shows "8", this error occurred under the condition of INITIAL SETTINGS has been released.

(Example; Factory assembling-line before unit shipment, Service mode etc.)

It means that this error is occurred at service side.

2) About "?" indication: ("18*0 0?01" to "18*0 0?50"):

The third digit from the right shows one of the hexadecimal ("0" to "F") character.

4. How to exit from Error Code display mode:

Simply, turn the power off. (Since Error code display mode is executed under the condition of temporary cancellation of "INITIAL SETTINGS", it wake up with normal condition when turn off the power.)

Note:

The error code can not be initialized.

7 Troubleshooting Guide

7.1 Wi-Fi Module (Top P.C.B. Unit)

7.1.1 How to Remove Wi-Fi Password Protection

To prevent incorrect operation or use of the Wi-Fi function by a third party and to protect saved personal information, this unit protects the Wi-Fi function with a password.

It is unable to service with password locked condition. When accepting for repair, the unit has been set the Wi-Fi password by customer, run the [Reset Wi-Fi Settings] for removing Wi-Fi password, then check the operation.

[Reset Procedure of Wi-Fi Settings]

1. Press the [MENU/SET] button, and select the [SETUP] mode by Cursor buttons, then press the [MENU/SET] button.
2. Select [Reset Wi-Fi Settings] by Cursor buttons, then press the [MENU/SET] button.
3. Select [YES] and press the [MENU/SET] button in several times.
(The [Reset Wi-Fi Settings] performs not only resetting Wi-Fi Password but also resetting other all Wi-Fi Settings.)

7.1.2 Checking of trouble caused by Wi-Fi Module on Top P.C.B. Unit or not

The Wi-Fi module works properly if the wireless access point (broadband router) name (SSID) in use is displayed on a screen of [Manual Connection].

(Primary Confirmation)

Confirm that the wireless access point (broadband router) works properly.

(Procedure)







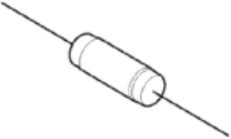
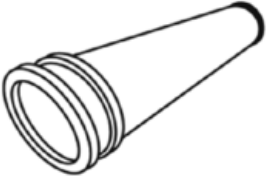
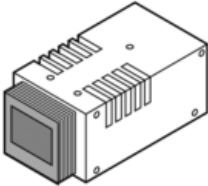

- 1) Press [Wi-Fi] button.
- 2) Select [New Connection] in [Wi-Fi] menu.
- 3) Select optional function in [select a function] menu, then select [Direct] in [Select connection method] menu.
- 4) Select [Manual Connection] in [Select connection method] menu.
- 5) The Wi-Fi module works properly if the wireless access point (broadband router) name (SSID) in use is displayed.

* Replace the Top P.C.B. Unit, when the above checking detected the abnormal of Wi-Fi module.

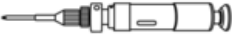
8 Service Fixture & Tools

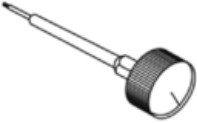
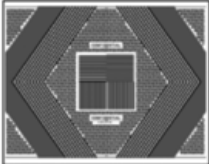
8.1 Service Fixture and Tools

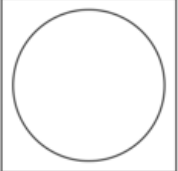
The following Service Fixture and tools are used for checking and servicing this unit.

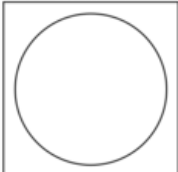
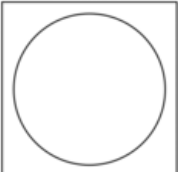
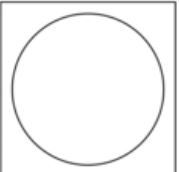
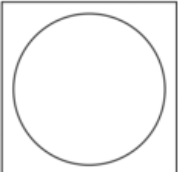
Resistor for Discharging (1k Ω /5W) ERG5SJ102	COLLIMATOR (built-in Focus Chart) RFKZ0422	LIGHT BOX (with DC Cable) RFKZ0523	
 * An equivalent type of resistor may be used.			
Lens Cleaning Kit (BK) VFK1900BK	Torque Driver RFKZ0542	Diffuser RFKZ0591	
 * Only supplied as 10 set/box.			
Driver (for Optical Axis Adjustment) RFKZ0609	Optical Axis Adjustment Chart RFKZ0570	Camera stand RFKZ0333J	
 * T3 Torx type			
Gray Card RFKZ0506	ND Filter (ND0.3) RFKZ0513	ND Filter (ND0.6) VFK1164ND06	ND Filter (ND0.9) VFK1164ND09
			
CC Filter (CC-C7.5) RFKZ0511	CC Filter (CC-Y10) RFKZ0512	LB Filter (LBB2) RFKZ0520	LB Filter (LBB8) RFKZ0521
			

8.2 When Replacing the Main P.C.B.

After replacing the Main P.C.B., be sure to achieve adjustment.

8.3 Service Position

This Service Position is used for checking and replacing parts. Use the following Extension cables for servicing.

No.	Parts No.	Connection	Form
1	RFKZ0619	FP9003 (Main P.C.B.) ↔ LCD Unit	61PIN / 0.3 FFC
2	RFKZ0477	FP9004 (Main P.C.B.) ↔ Lens Unit	45PIN / 0.3 FFC

8.3.1 Extension Cable Connections

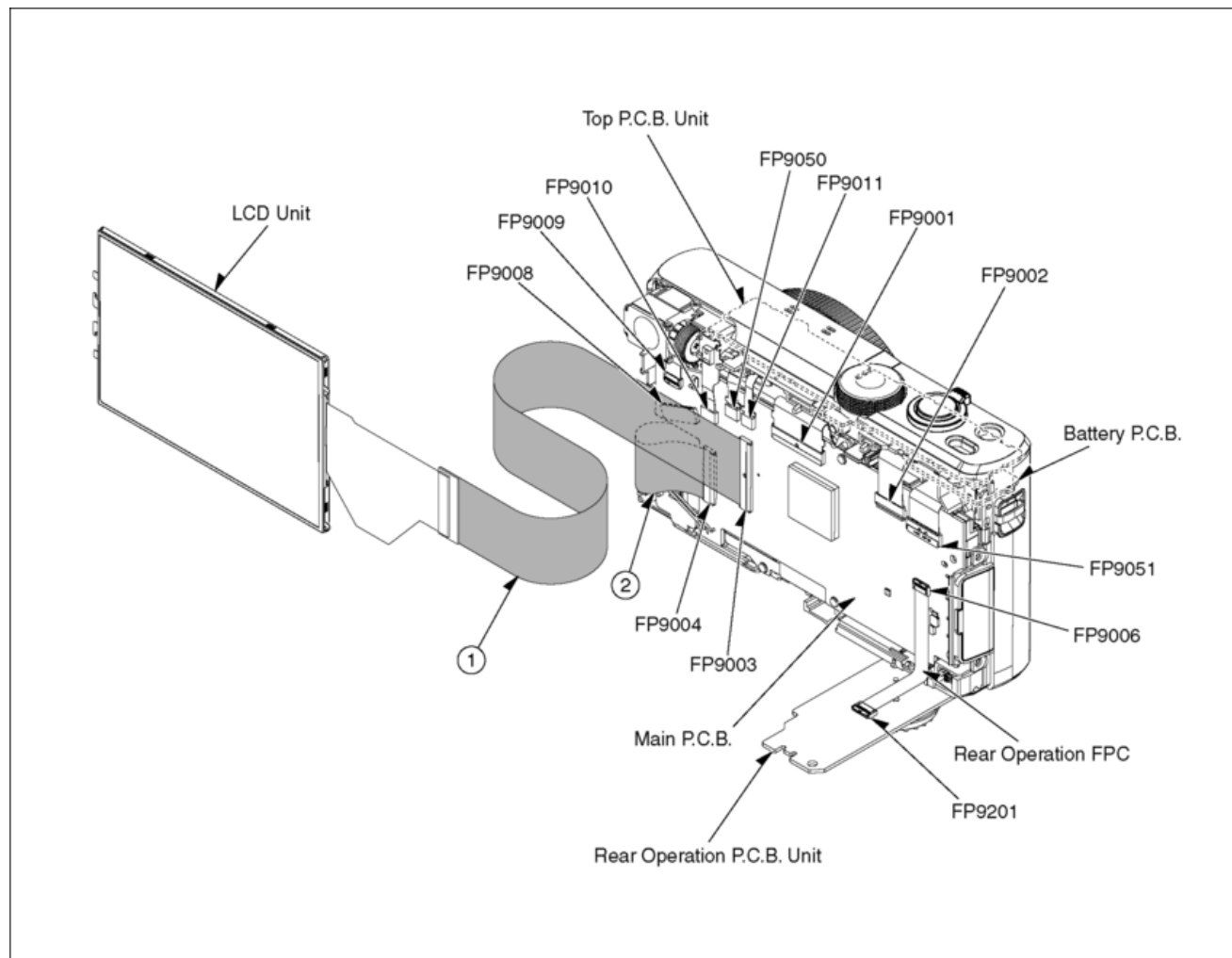

CAUTION (When servicing Top P.C.B. Unit)

1. Be sure to discharge the capacitor on Top P.C.B. Unit.
Refer to "HOW TO DISCHARGE THE CAPACITOR ON Top P.C.B. Unit".
The capacitor voltage is not lowered soon even if the AC Cord is unplugged or the battery is removed.
2. Be careful of the high voltage circuit on Top P.C.B. Unit.
3. DO NOT allow other parts to touch the high voltage circuit on Top P.C.B. Unit.

9 Disassembly and Assembly Instructions

9.1 Disassembly Flow Chart

This is a disassembling chart.

When assembling, perform this chart conversely.

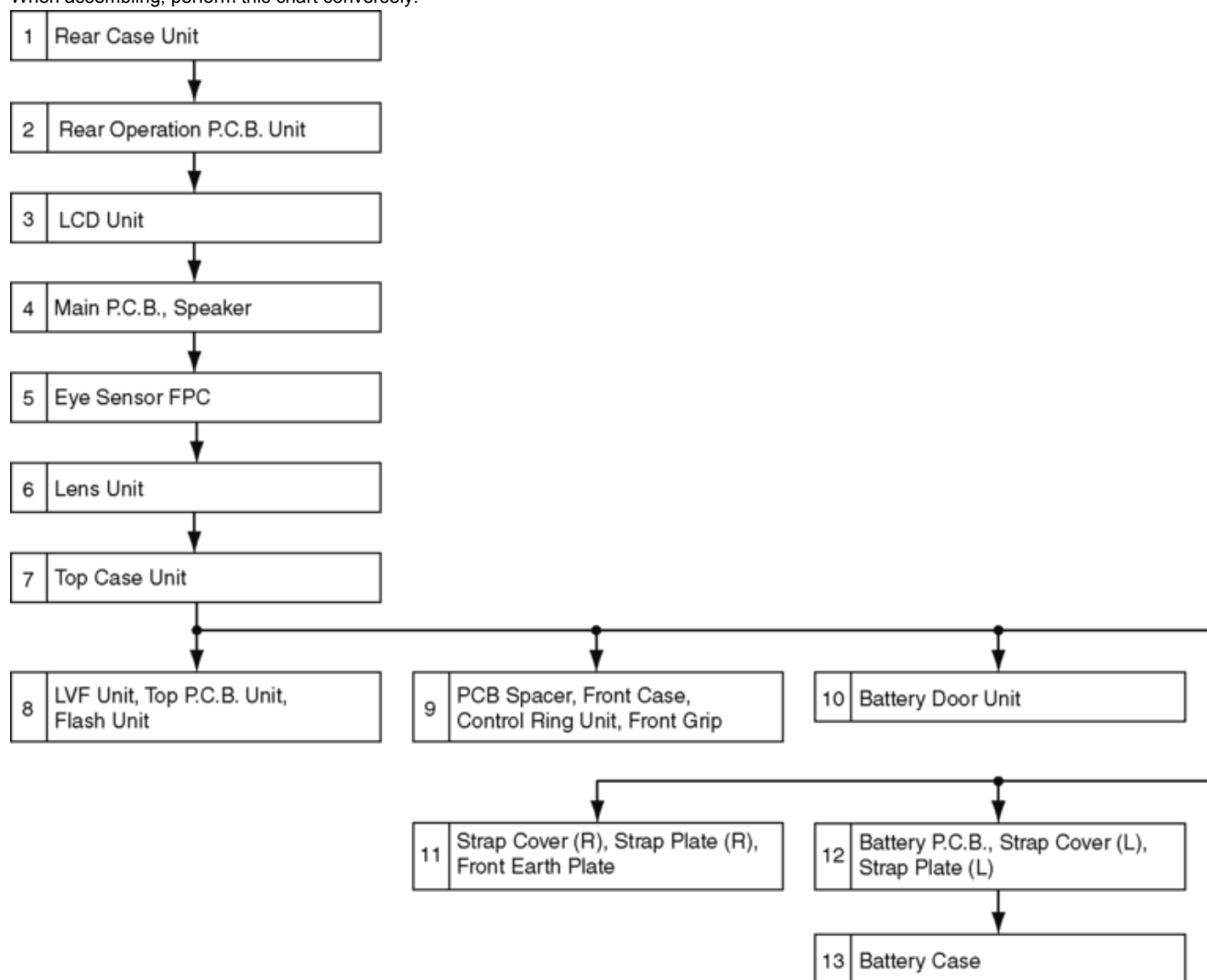

9.2 P.C.B. Location

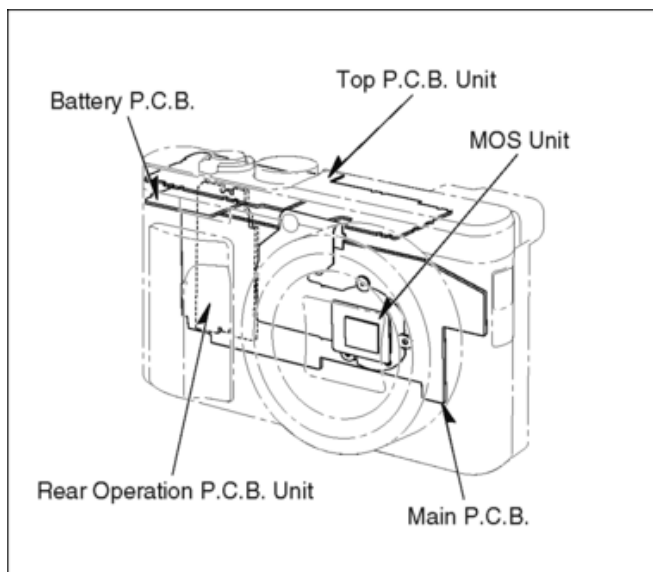

9.3 Disassembly Procedure

No.	Item	Fig.	Removal
1	Rear Case Unit	(Fig. D1)	Screw (A) × 6 Locking tab × 5 Jack Base Unit Jack Cover Rear Case Unit
2	Rear Operation P.C.B. Unit	(Fig. D2)	Locking tab × 1 FP9006 (Flex) Rear Operation FPC Rear Operation P.C.B. Unit
3	LCD Unit	(Fig. D3)	Locking tab (A) × 2 Screw (B) × 2 Locking tab (B) × 1 Frame Plate Unit Battery Lock Spring Battery Lock Knob FP9003 (Flex) LCD Unit
		(Fig. D4)	Note: (When replacing Frame Plate Unit) Frame Plate Sheet
4	Main P.C.B., Speaker	(Fig. D5)	Locking tab × 2 Speaker Plate Unit FP9001 (Flex) FP9002 (Flex) FP9004 (Flex) FP9008 (Flex) FP9009 (Flex) FP9010 (Flex) FP9011 (Flex) FP9050 (Flex) FP9051 (Flex) Screw (C) × 3 Heat Radiation Pad Main P.C.B.
		(Fig. D6)	Note: (When replacing Main P.C.B.) Heat Radiation Pad, CU Protection Sheet
		(Fig. D7)	Solder (2 points) Speaker
5	Eye Sensor FPC	(Fig. D8)	Positioning boss × 2 Hooking part × 2 Eye Sensor FPC
6	Lens Unit	(Fig. D9)	Screw (D) × 3

			Lens Fix Plate Lens Unit
7	Top Case Unit	(Fig. D10)	Screw (E) × 1 Locking tab × 2 Top Case Unit
8	LVF Unit, Top P.C.B. Unit, Flash Unit	(Fig. D11)	Screw (F) × 3 Locking tab (A) × 2 LVF Unit Top P.C.B. Unit MIC Spacer MIC Unit MIC Damper Solder A (3 points) Locking tab (B) × 2 AF Panel Light Flash Spacer Earth Spring E. Capacitor Solder B (3 points) Flash Unit Top Earth Plate A Top Earth Plate B WiFi FPC Top FPC
		(Fig. D12)	Note: (When replacing Top P.C.B. Unit, LVF Unit)
9	PCB Spacer, Front Case, Control Ring Unit, Front Grip	(Fig. D13)	Hooking part × 2 PCB Spacer Screw (G) × 1 Locking tab (A) × 1 Front Case Screw (H) × 5 Locking tab (B) × 3 Control Ring Unit Front Grip
10	Battery Door Unit	(Fig. D14)	Battery Door Shaft Battery Door Spring Battery Door Unit Tripod
11	Strap Cover (R), Strap Plate (R), Front Earth Plate	(Fig. D15)	Screw (I) × 1 Locking tab (A) × 1 Locking tab (B) × 1 Strap Cover (R) Hooking part × 2 Positioning boss × 2 Strap Plate (R) Front Earth Plate
12	Battery P.C.B., Strap Cover (L), Strap Plate (L)	(Fig. D16)	Screw (J) × 1 Battery FPC Hooking part × 1 Battery P.C.B Locking tab (A) × 1 Locking tab (B) × 2 Strap Cover (L) Strap Plate (L)
13	Battery Case	(Fig. D17)	Hooking part × 4 Battery Case Gasket

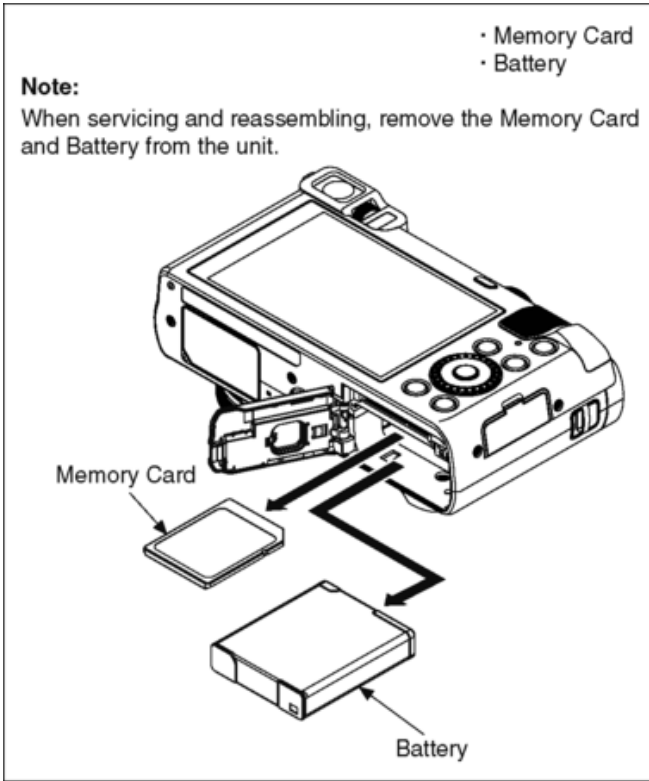

9.3.1 Removal of the Rear Case Unit

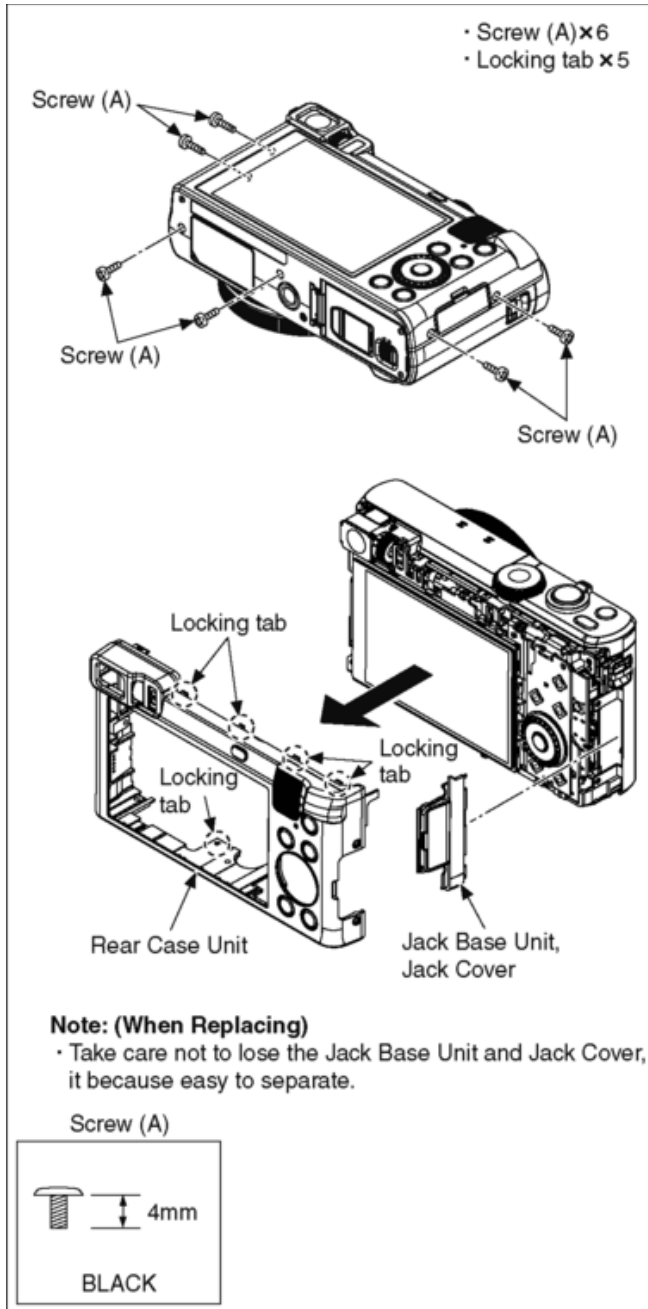

Fig. D1

9.3.2 Removal of the Rear Operation P.C.B. Unit

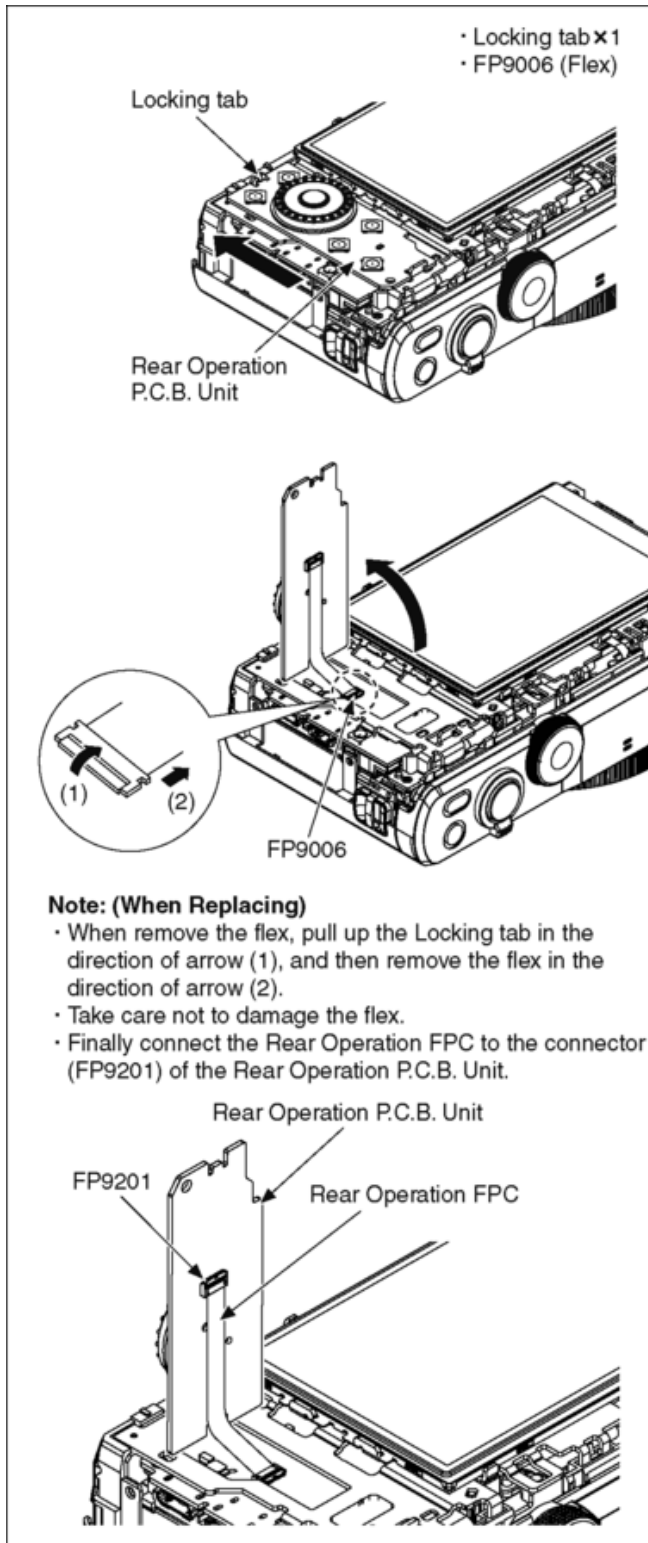
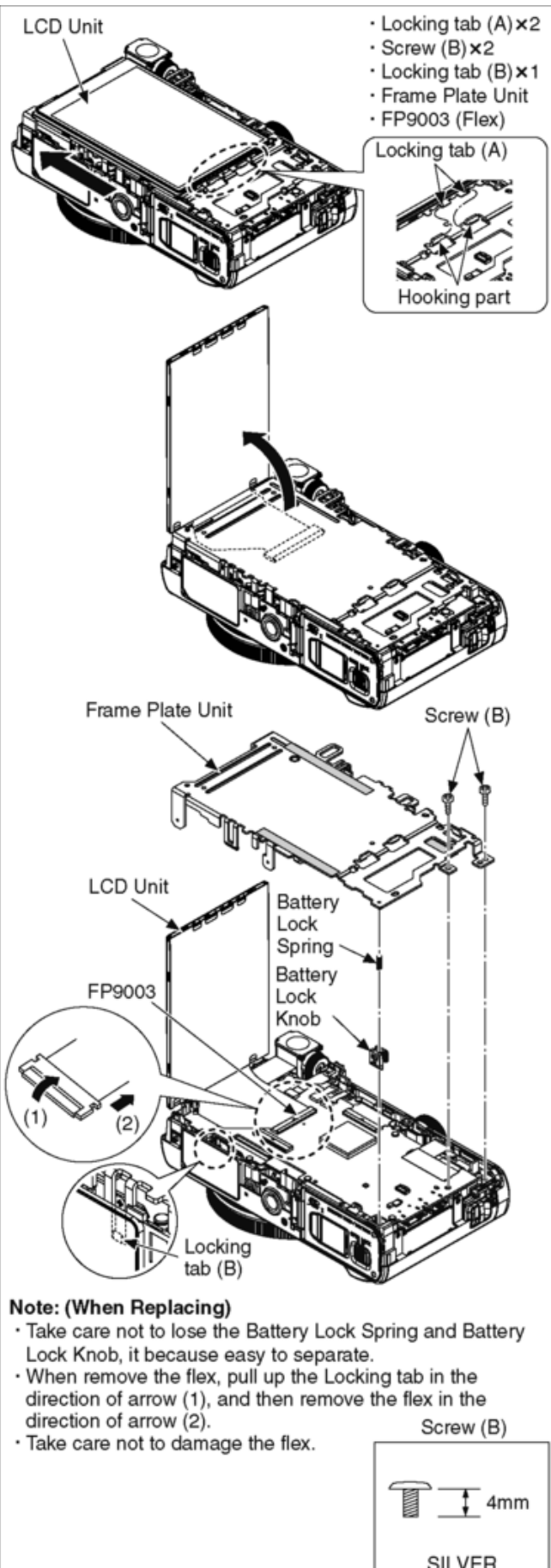

Fig. D2

9.3.3 Removal of the LCD Unit



Note: (When Replacing)

- When replacing the Frame Plate Unit, replace the Frame Plate Sheet as well.
For how to attach the Frame Plate Sheet, see below.

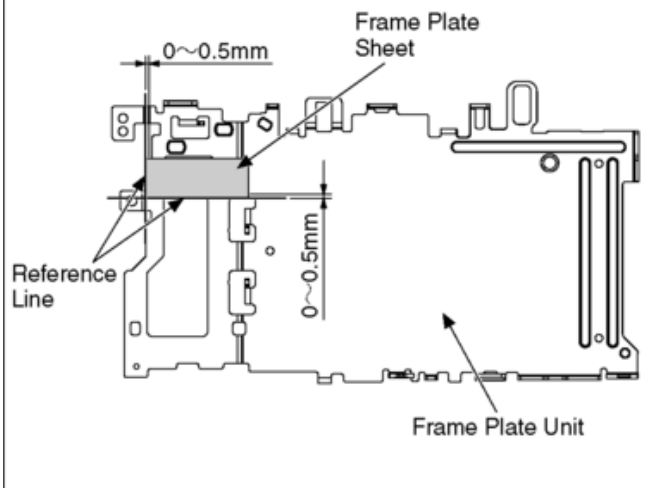
**9.3.4 Removal of the Main P.C.B., Speaker**

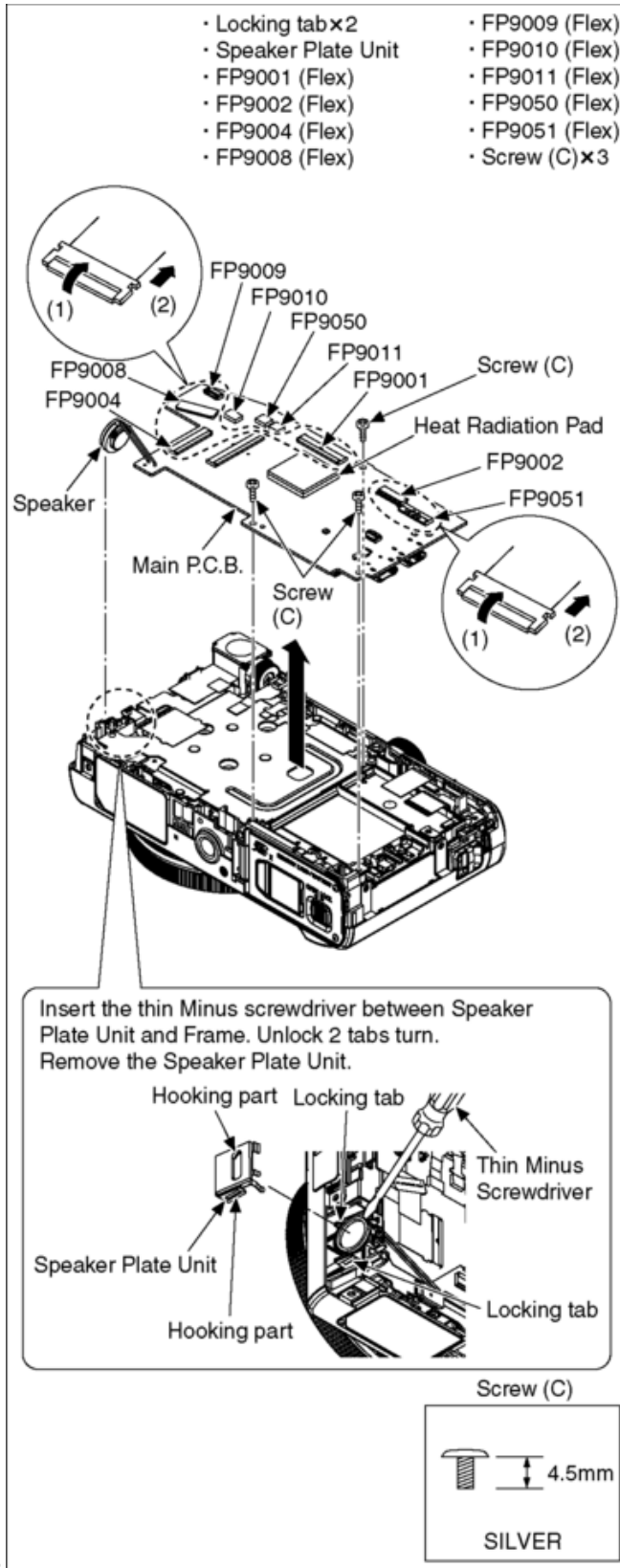

Fig. D5

Fig. D6

Note: (When Replacing)

- When remove the flex, pull up the Locking Tab in the direction of arrow (1), and then remove the flex in the direction of arrow (2).
- Take care not to damage the flex.
- When attaching the Heat Radiation Pad, confirm the attaching position to attach.
- When attaching the CU Protection Sheet, confirm the attaching position to attach.

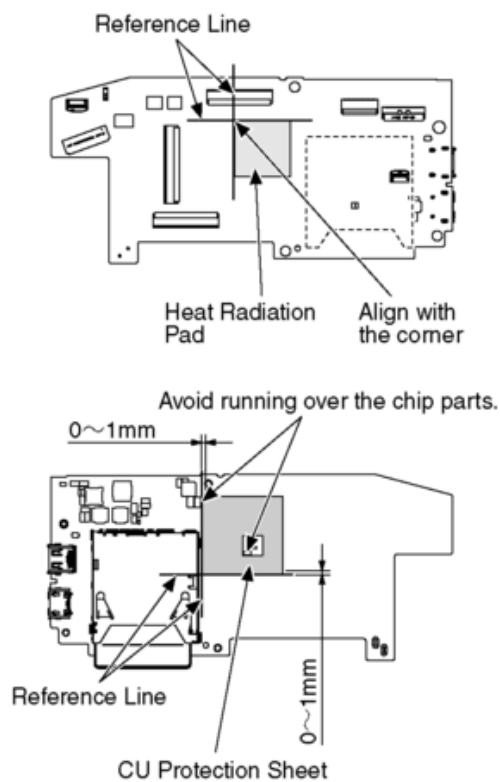
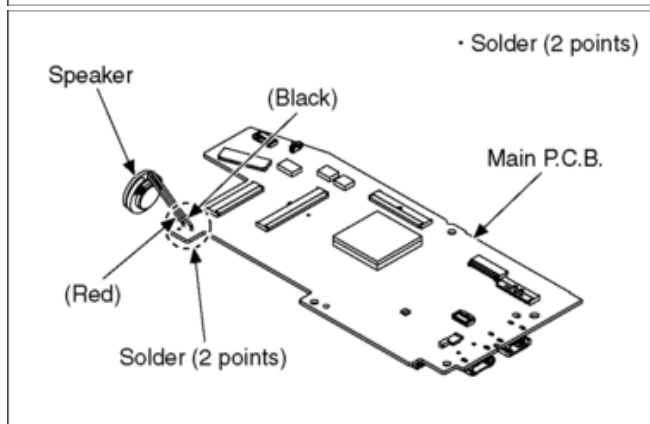

Fig. D7

**9.3.5 Removal of the Eye Sensor FPC**

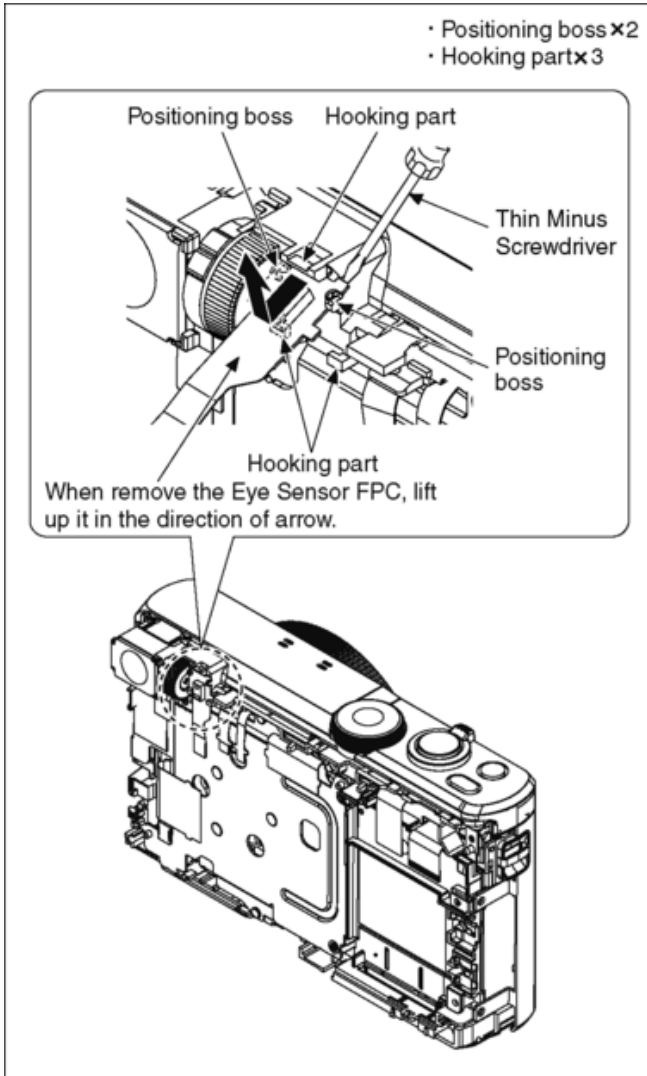

Fig. D8

9.3.6 Removal of the Lens Unit

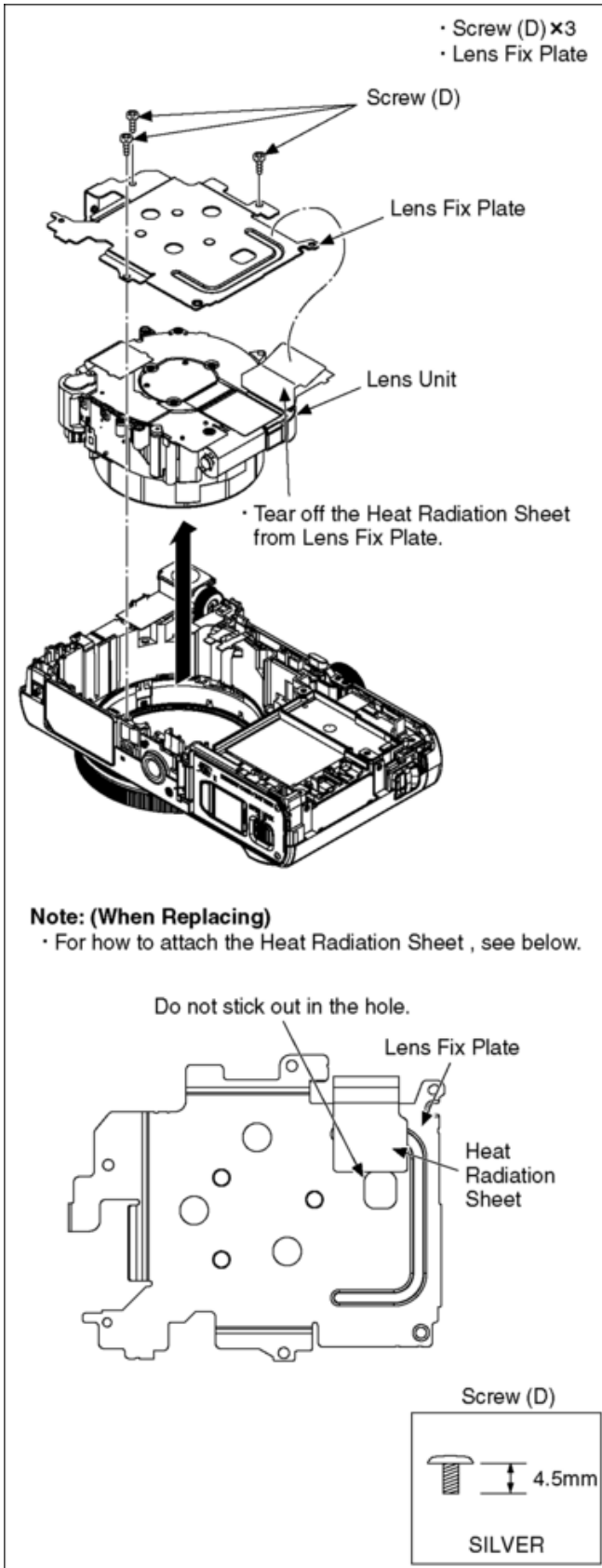

Fig. D9

9.3.7 Removal of the Top Case Unit

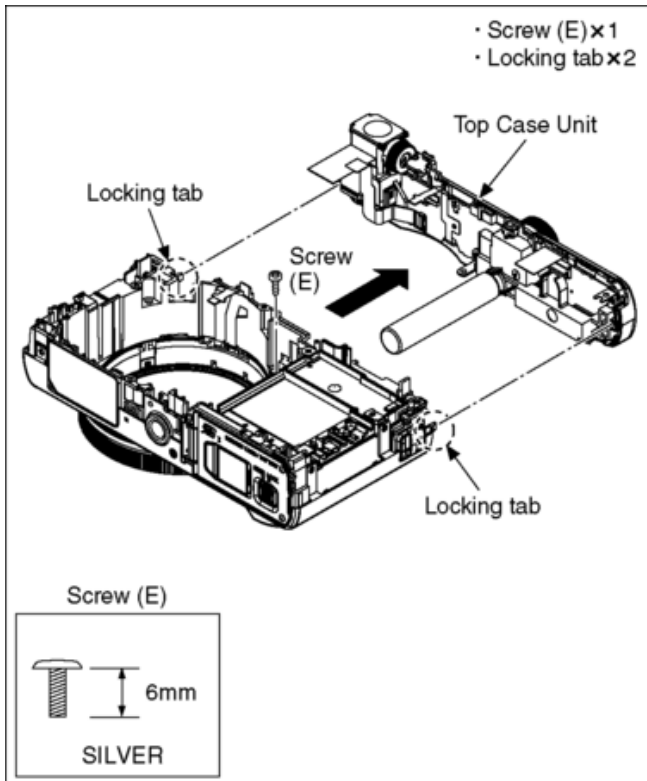
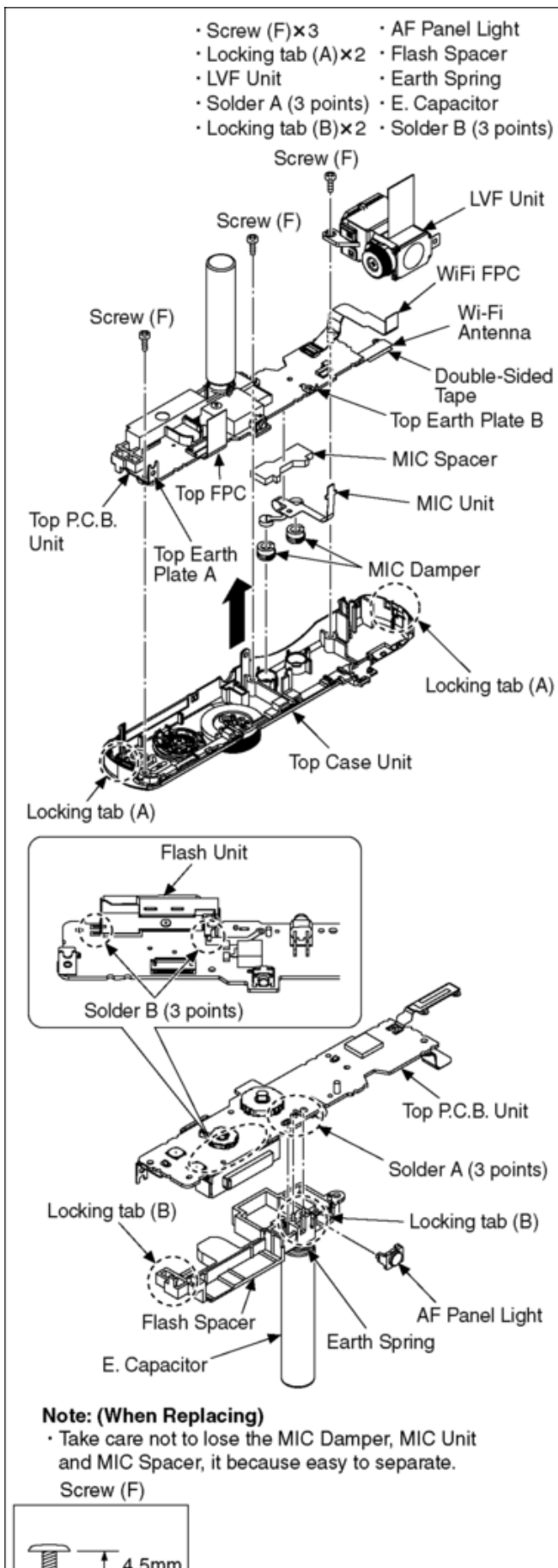

Fig. D10

9.3.8 Removal of the LVF Unit, Top P.C.B. Unit, Flash Unit



Note: (When Replacing)

- Remove the Wi-Fi Antenna slowly and carefully.
- When attaching the Wi-Fi Antenna, confirm the attaching position to attach.
- Top P.C.B. and Wi-Fi Antenna are unit supply.

※ Set the Zoom Switch to the center position and fix with the Zoom Lever.

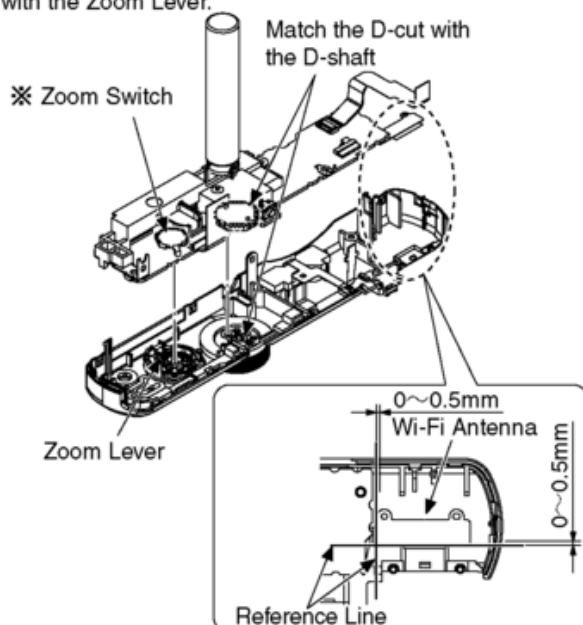

- Take care not to put fingerprint of the finder part of LVF unit.
- Insert the LVF Unit to the boss of the top case and then attach. (See below.)

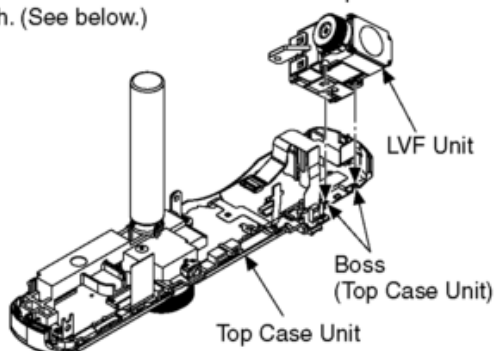
**IMPORTANT NOTICE:**

Take care not apply any bending load to the charging capacitor. It brings about the possibility of P.C.B. and/or component damage on the Top P.C.B. Unit.

⚠ CAUTION

Be sure to discharge the capacitor on Top P.C.B. Unit before disassembling.

1. Remove the Top P.C.B. Unit.
2. Put the insulation tube on the lead part of resistor (ERG5SJ102: 1k Ω /5W).
3. Put the resistor between both terminals of capacitor unit for approx. 5 seconds.

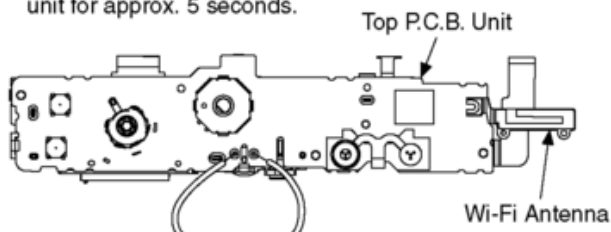

9.3.9 Removal of the PCB Spacer, Front Case, Control Ring Unit, Front Grip

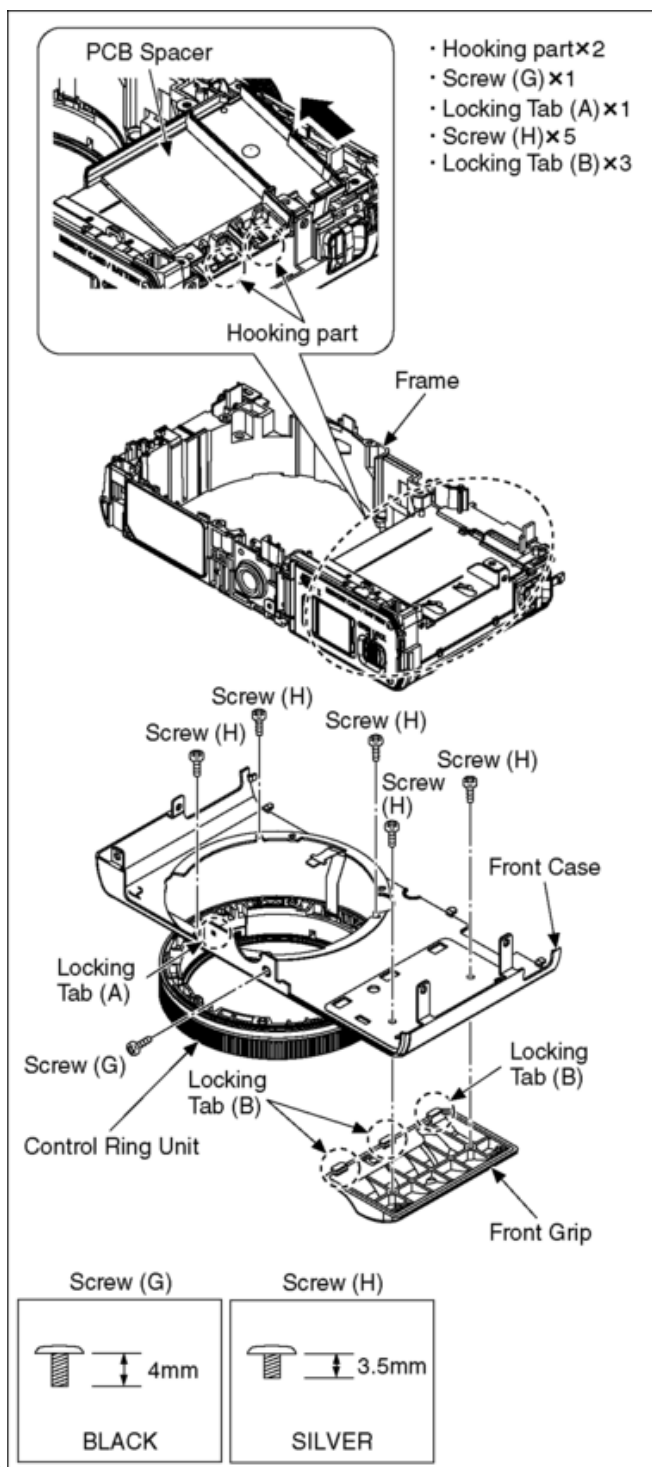

Fig. D13

9.3.10 Removal of the Battery Door Unit

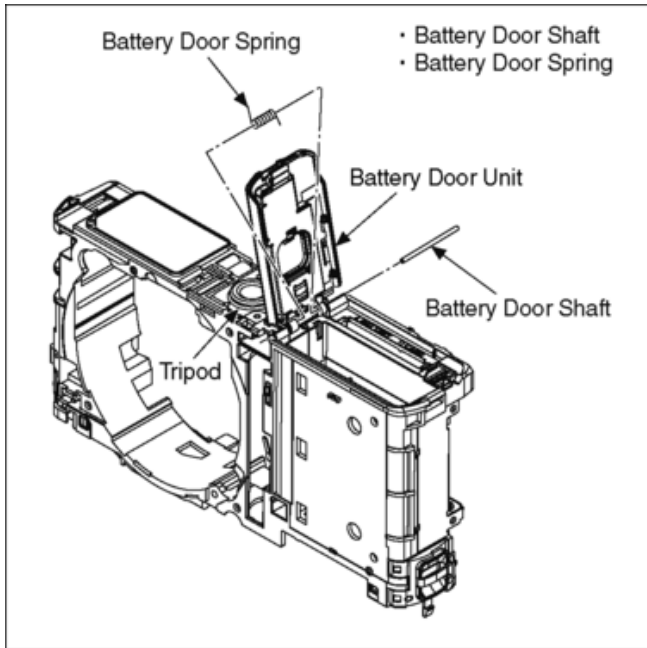

Fig. D14

9.3.11 Removal of the Strap Cover (R), Strap Plate (R), Front Earth Plate

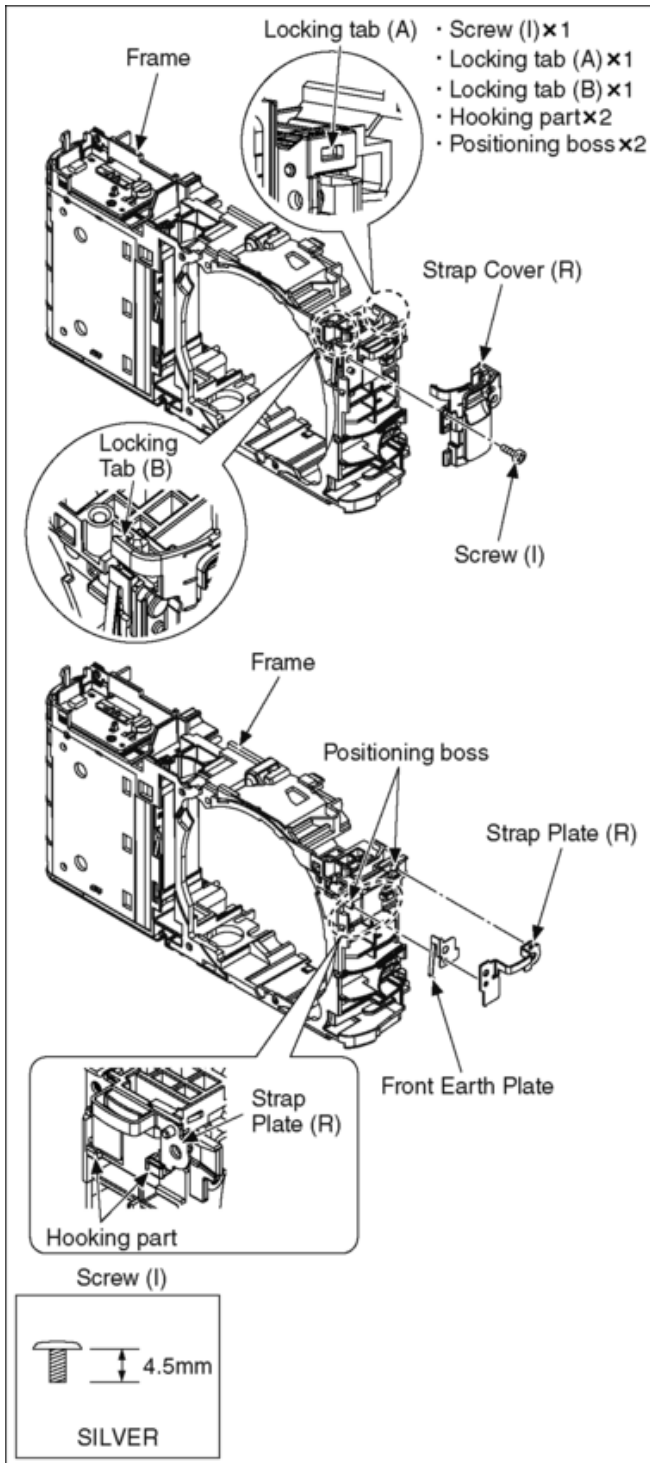

Fig. D15

9.3.12 Removal of the Battery P.C.B., Strap Cover (L), Strap Plate (L)

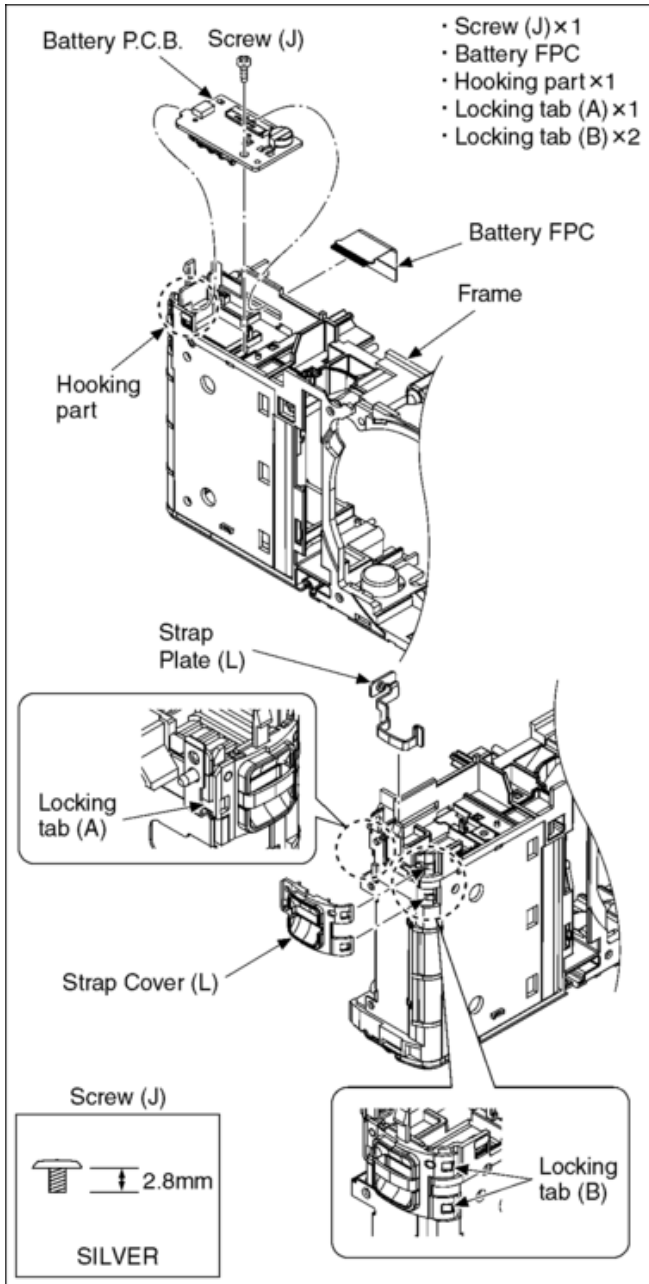

Fig. D16

9.3.13 Removal of the Battery Case

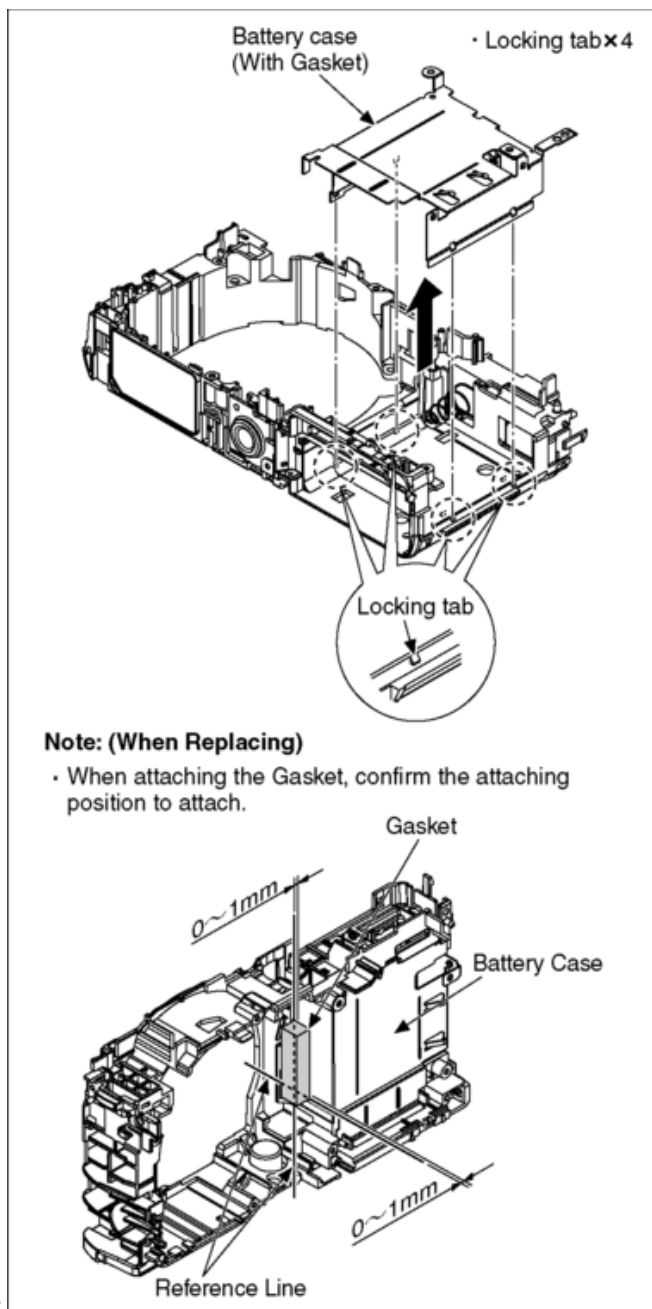

Fig. D17

9.4 Lens Disassembly Procedure

Precaution:

- Do not remove the MOS when disassembling or re-assembling the lens in order to maintain it clean. When remove it, refer to item "9.6".
- Keep dust or dirt away from the lens.
- To remove dirt or dust from the lens, blow with dry air.
- Do not touch the lens surface.
- Use lens cleaning KIT (BK)(VFK1900BK).

9.4.1 Removal of the Master Flange Unit

- Unscrew the 1 screw (A) to remove the sensor of Zoom Motor.
- Unscrew the 2 screws (B) to remove the sensor of Focus Motor.
- Unsolder 4 points to remove the Focus Motor FPC.

4. Unsolder 18 points to remove the Shutter FPC from Lens FPC Unit.
5. Unsolder 2 points to remove the Lens FPC Unit.
6. Unscrew the 6 screws (C) to remove the Master Flange Unit.

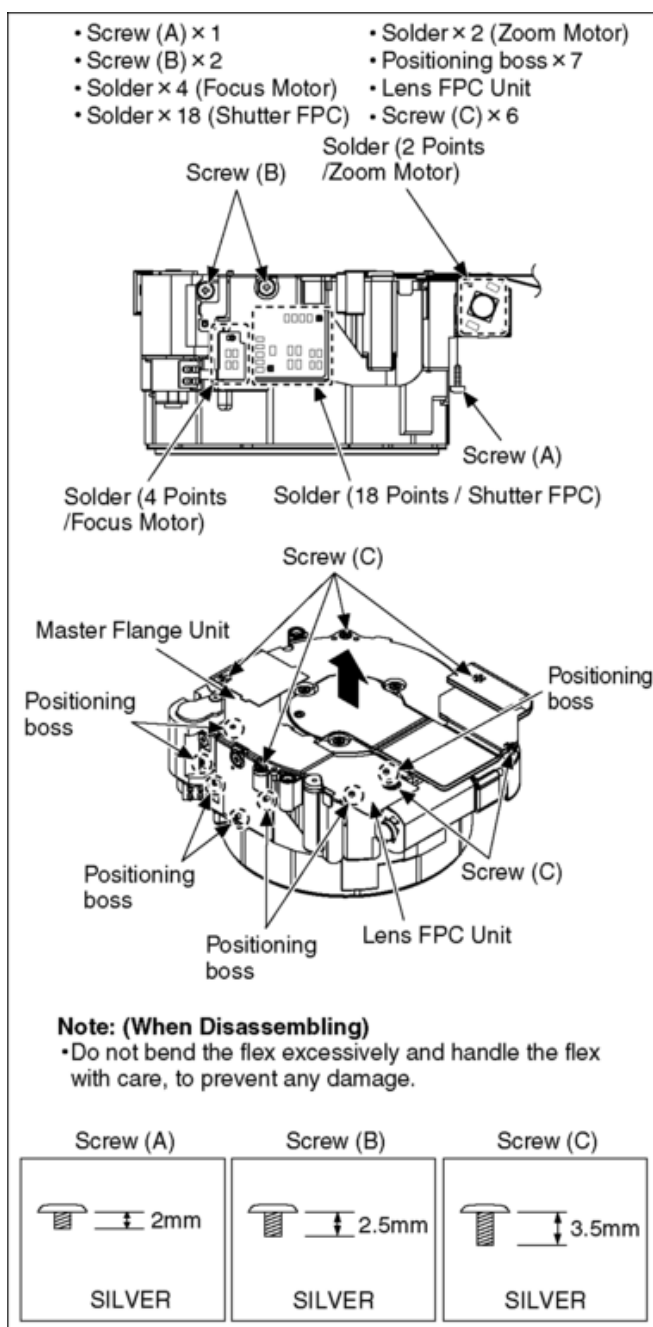

9.4.2 Both Side Cam Frame, 1st Lens Unit, 2nd Lens Unit and 3rd Lens Unit

1. Pull out the Relay Gear using tweezers, etc.
2. Turn the Gear of Fix Frame Unit using Slotted Driver, etc. in the direction of arrow.
3. Push the 1st Lens Frame Unit to the indicated by arrow from lens side, then remove the unit of Both Side Cam Frame Unit, 1st Lens Frame Unit, 2nd Lens Frame Unit and 3rd Lens Unit from Fix Frame Unit.

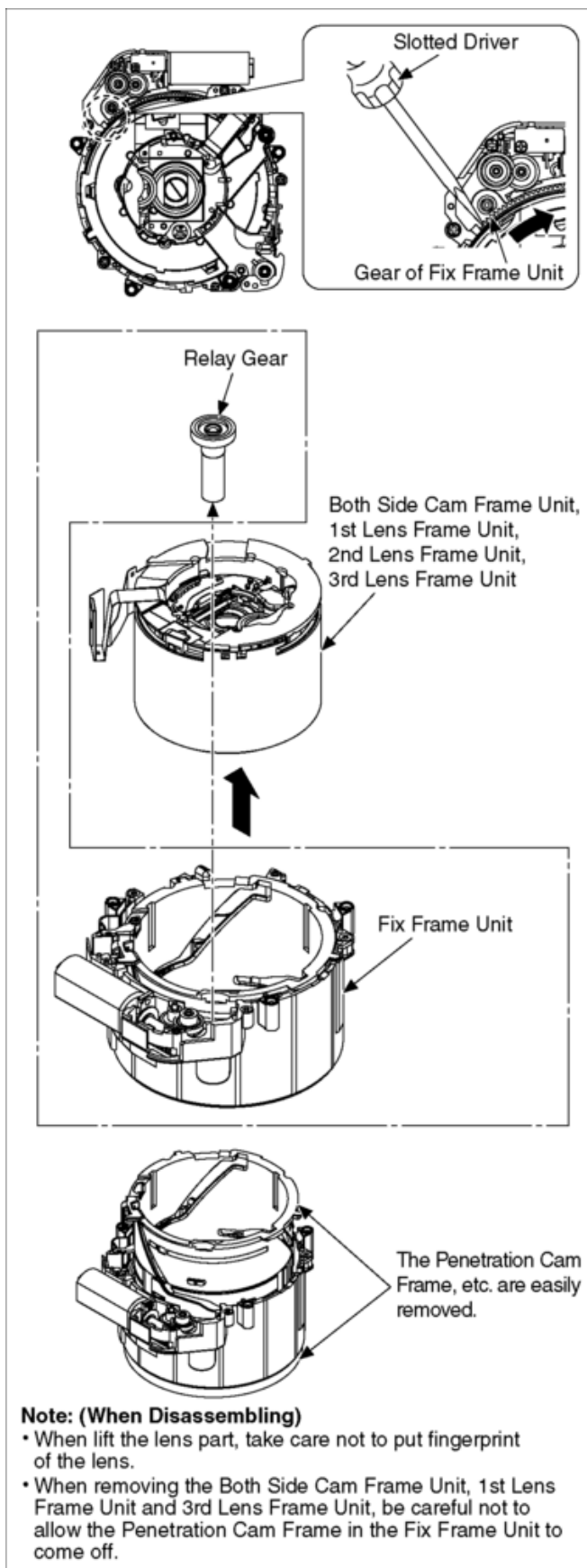

9.4.3 Removal of the 1st Lens Frame Unit and 3rd Lens Frame Unit

1. Turn the 3rd Lens Frame Unit in the direction of arrow fully.
2. Remove the 1st Lens Frame Unit and 3rd Lens Frame Unit from the Both Side Cam Frame Unit.

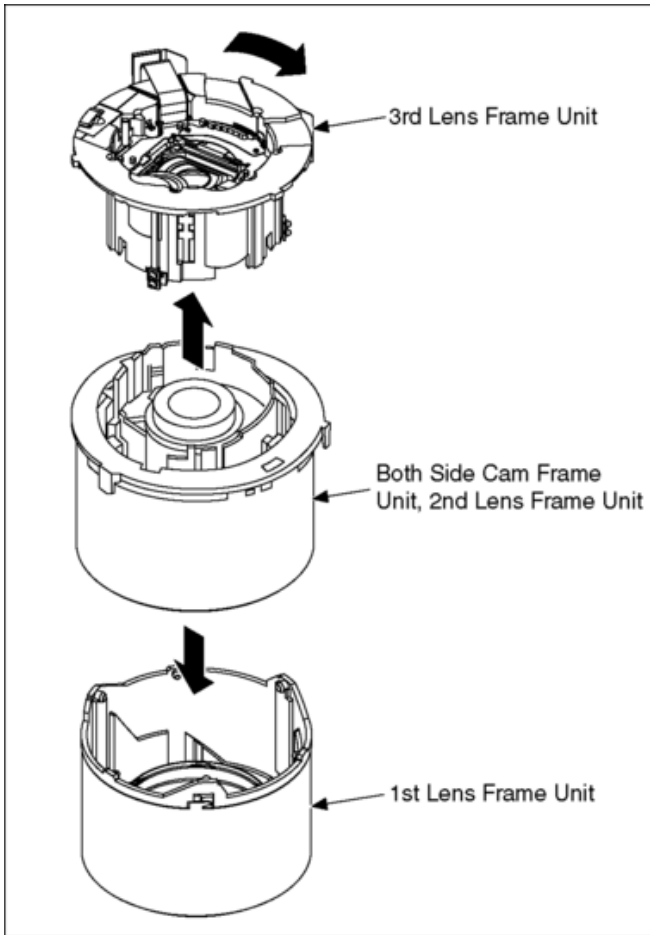

9.4.4 Removal of the 2nd Lens Frame Unit

1. Turn the Straight Frame using Slotted Driver, etc. and then align the Groove of Straight Frame and Groove of Both Side Cam Frame Unit.

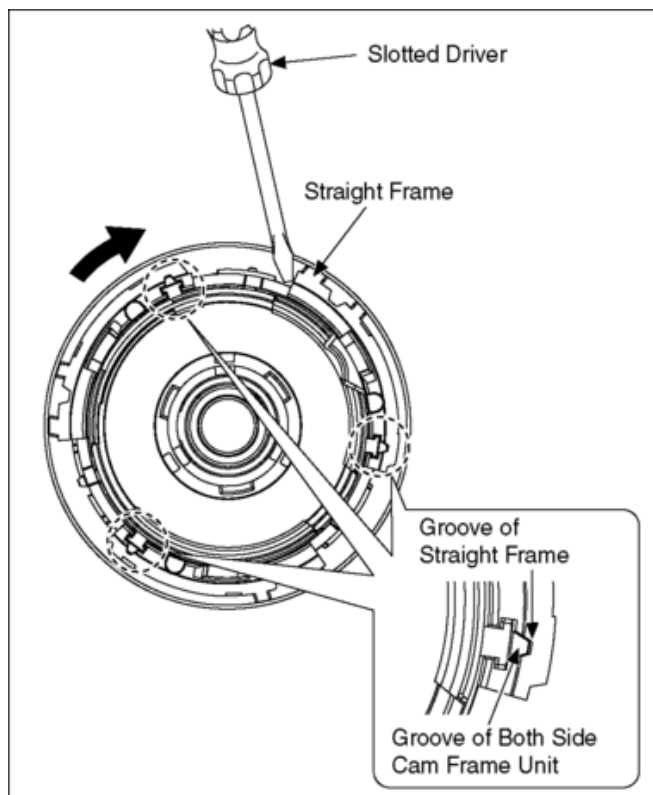

2. Remove the 2nd Lens Frame Unit from the Both Side Cam Frame Unit.

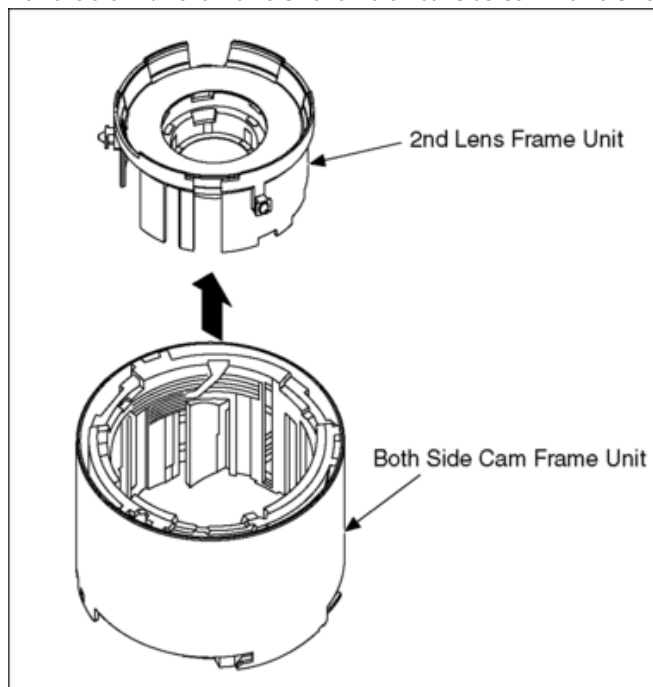

9.5 Assembly Procedure for Lens

9.5.1 Insert the 2nd Lens Frame Unit

1. Turn the Straight Frame in the direction of arrow, then align the convex portion of Straight Frame and the concave portion of Both Side Cam Frame Unit.
* Refer to the OIS Drive Lever portion of Straight Frame as shown below.

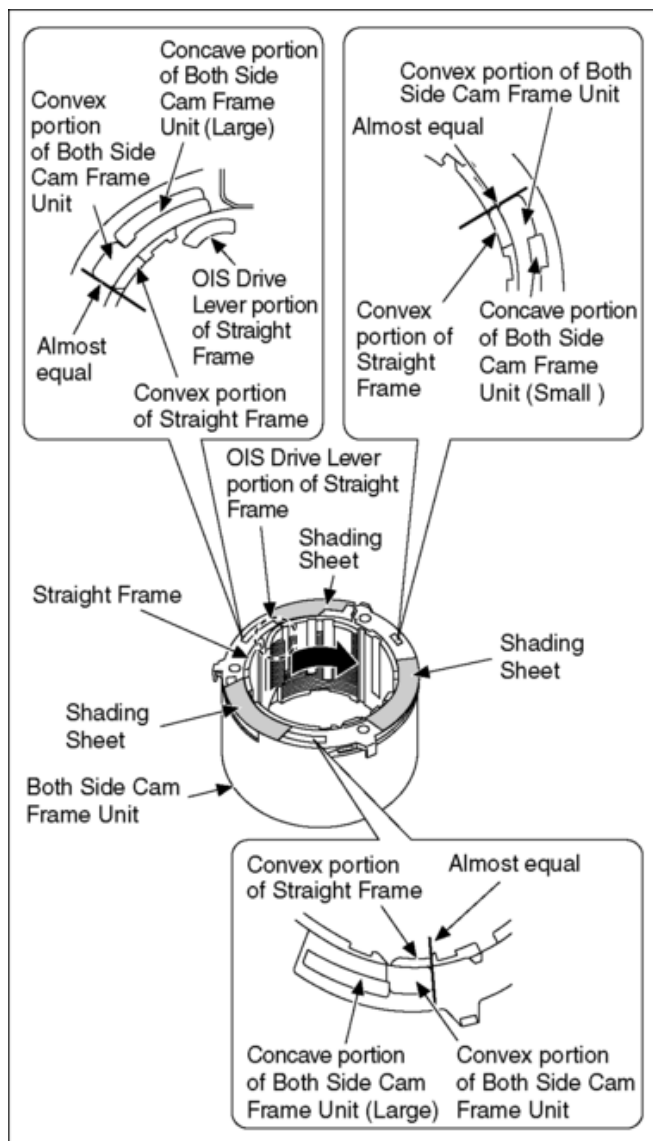

2. Insert the 2nd Lens Frame Unit as the drawing below indicated.

* Align the portion without an external wall of the 2nd Lens Frame Unit with the OIS Drive Lever portion of the Straight Frame, then put the each Cam Pin of the 2nd Lens Frame in the each Groove of the Both Side Cam Frame Unit and the Straight Frame.

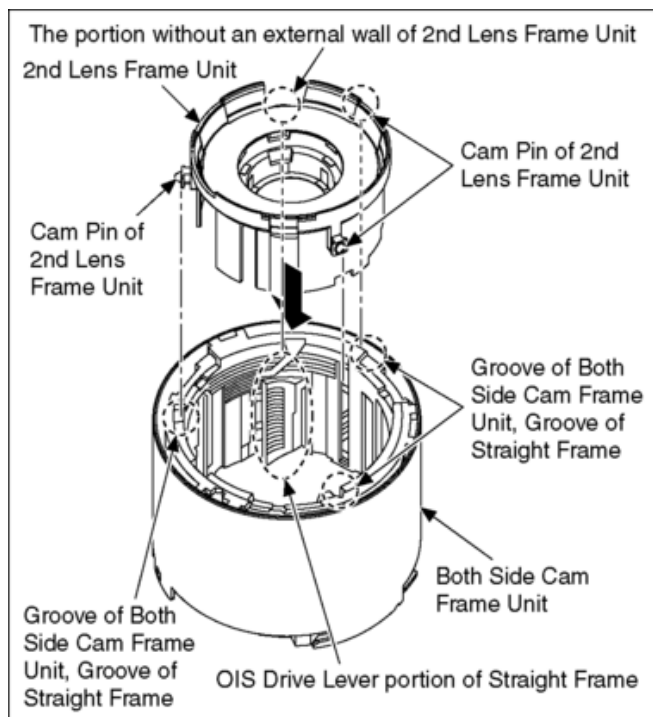

9.5.2 Insert the 1st Lens Frame Unit

1. Turn the Straight Frame using Slotted Driver, etc., then turn it in the direction of arrow fully. (Turn the Straight Frame to the "Tele" position.)

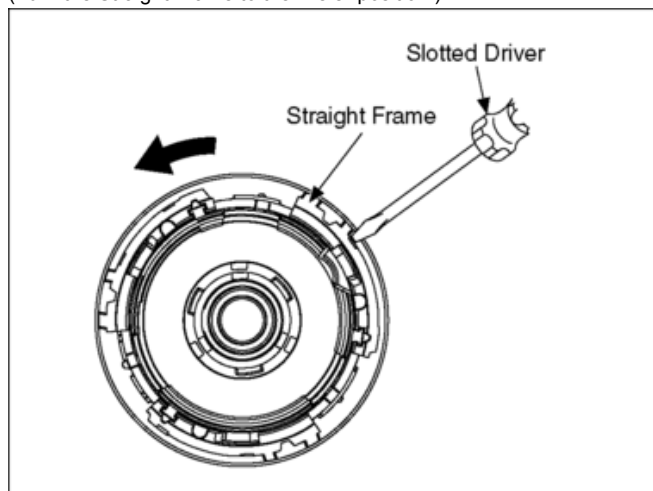

2. Insert the 1st Lens Frame Unit as the drawing below indicated.
 - (1) Position the printing portion (LEICA) of the 1st Lens Frame Unit and the OIS Drive Lever portion of the Both Side Cam Frame Unit as shown below. (deviated approx. 60 degrees)
 - (2) Insert the each Cam Pin of the 1st Lens Frame Unit in the each Groove of the Both Side Cam Frame Unit and the Straight Frame.

* Check if the 2nd Lens Frame Unit moves smoothly when the 1st Lens Frame Unit is rotated.

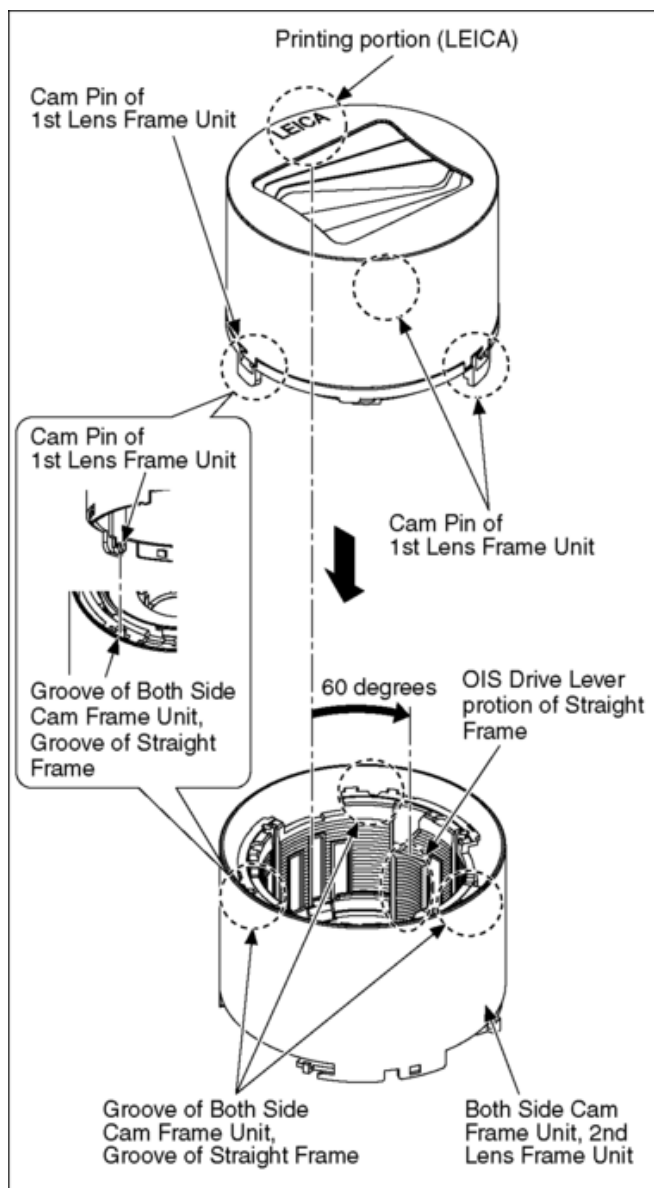

9.5.3 Insert the 3rd Lens Frame Unit

1. Insert the 3rd Lens Frame Unit as the drawing below indicated.
 - (1) Restore the position to the state ("Tele" position) when the 1st Lens Frame Unit is inserted.
(Align the each Groove of the Straight Frame and the each Groove of the both Side Cam Frame Unit.)
 - (2) Align the metal part of the 3rd Lens Frame Unit with the metal part of the 2nd Lens Frame Unit.
 - (3) Insert the each Cam Pin of the 3rd Lens Frame Unit and Shutter Cam Pin in the each Groove of the Both Side Cam Frame Unit and the Straight Frame.
2. Make the lens into a retracted position state. ("Wide" position)
(Turn the 1st Lens Frame Unit and 3rd Lens Frame Unit in the direction of arrow fully.)

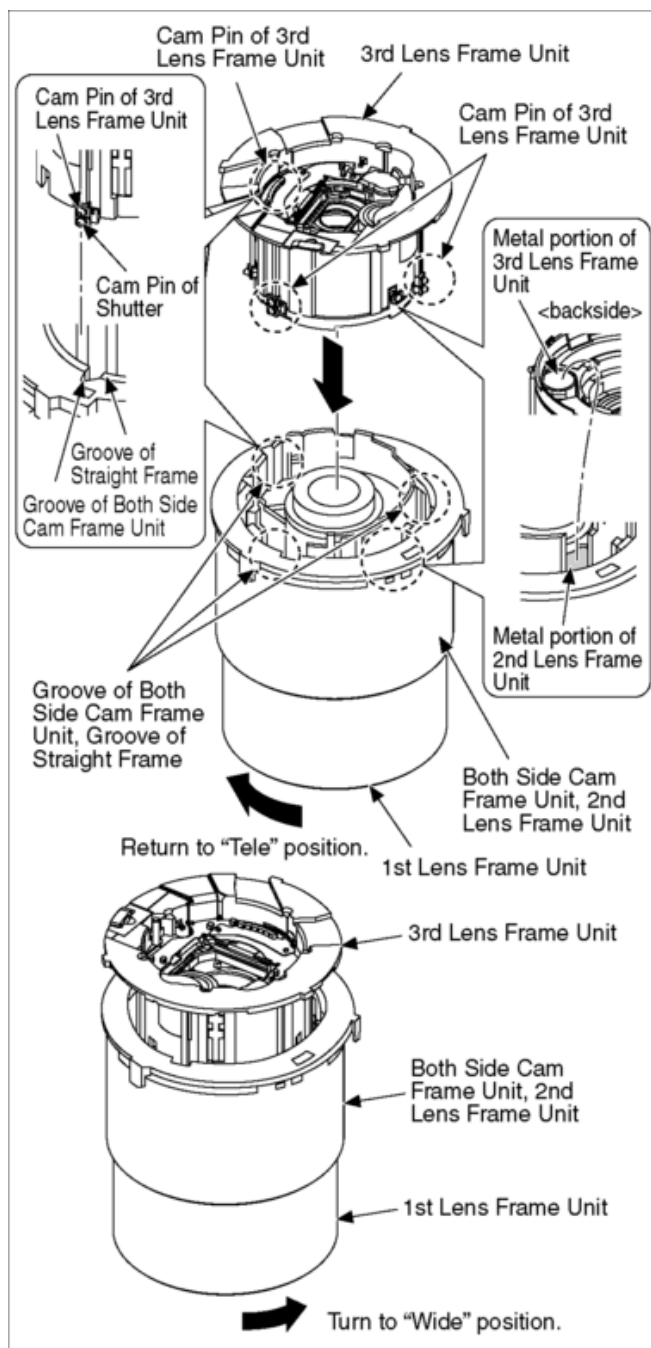

9.5.4 Insert the Fix Frame Unit

Note: (When Installing)

When using the Fix Frame Unit of service part, remove the Master Flange Unit (used to prevent fall of the gear) and the Relay Gear before assembling the Fix Frame Unit.

1. Align the Zoom Motor of the Fix Frame Unit with the Shutter FPC, then put the each Cam Pin of the Both Side Cam Frame Unit in the each Groove of Penetration Cam Frame.
2. Insert the Relay Gear to the Fix Frame Unit.

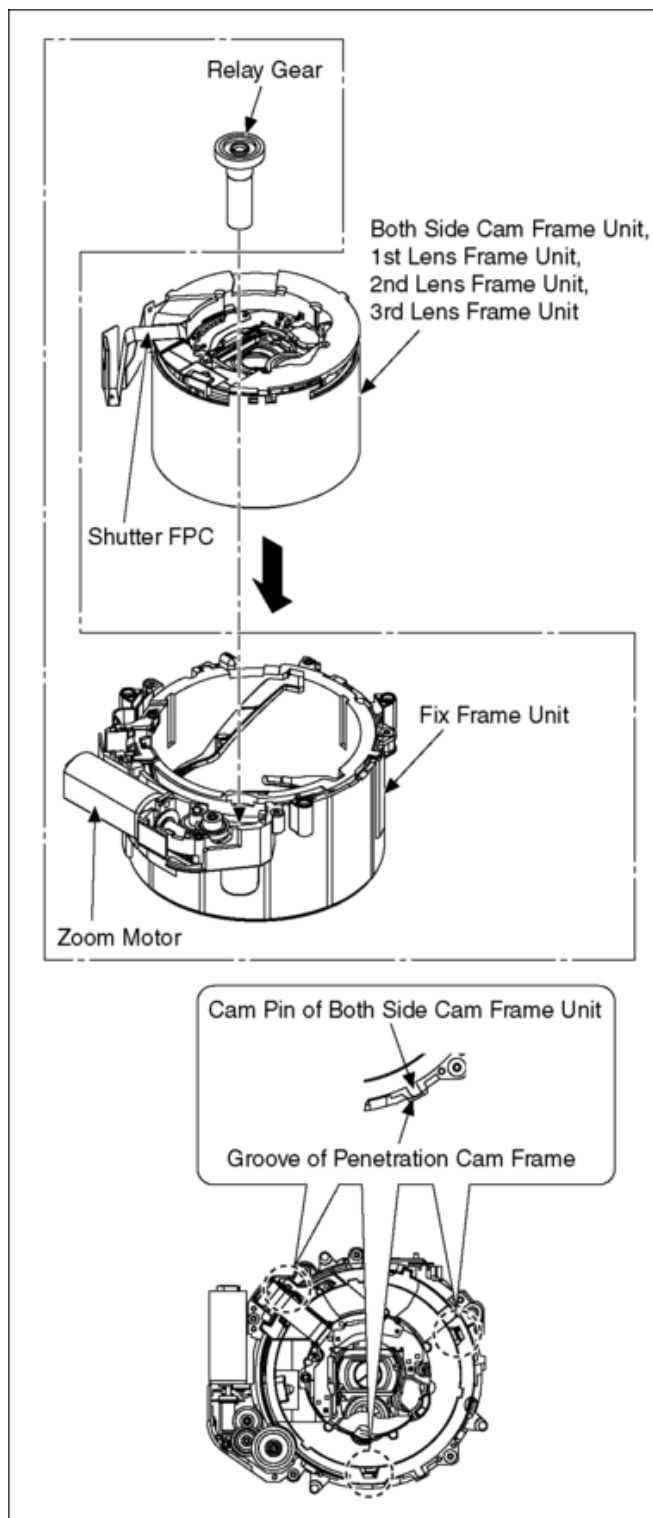

9.5.5 Insert the Master Flange Unit

Note: (When Installing)

Take Care not to damage the flex.

Take Care not to tuck in to the Master Flange Unit, When inserting the Shutter FPC.

1. Push the Hole of the Shutter FPC to the Boss of the Master Flange Unit tightly.
2. Place the Shutter FPC following the Guide of the Fix Cam Frame, and install the Master Flange Unit to the Unit of Both Side Cam Frame Unit, 1st Lens Frame Unit, 2nd Lens Frame Unit, 3rd Lens Frame Unit and Fix Frame Unit.
3. Check if the positioning boss of the Shutter PFC and shaft of the Master Flange Unit are inserted into the designated hole of the

Both Side Cam Frame Unit.

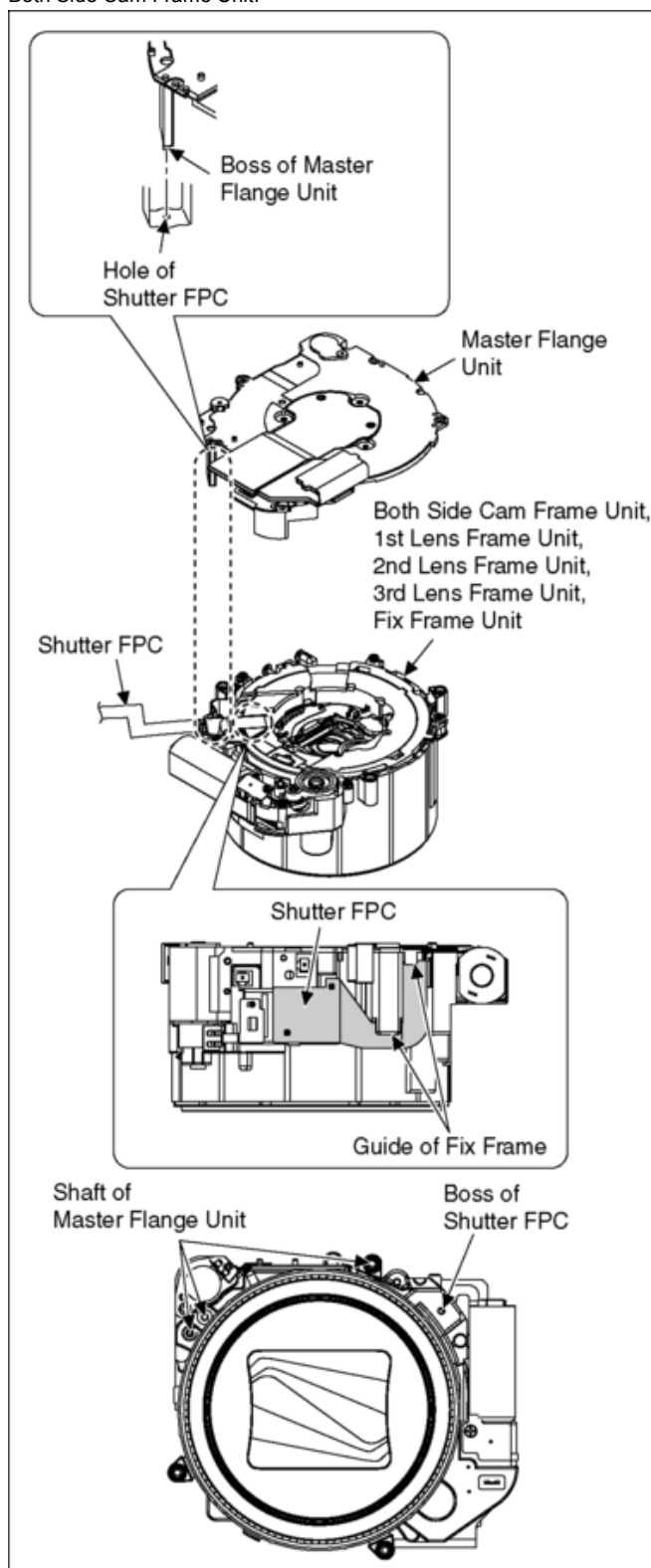

4. Attach the Master Flange Unit, then tighten 6 screws (A).
5. Attach the sensor for Focus Motor of Lens FPC Unit, then tighten 2 screws (B).
6. Attach the sensor for Focus Motor of Lens FPC Unit, then tighten 1 screw (C).
7. Soldering the Lens FPC Unit and the Shutter FPC. (18 points)
8. Soldering the Lens FPC Unit and the Zoom Motor. (2 points)
9. Soldering the Lens FPC Unit and the Focus Motor FPC. (4 points)

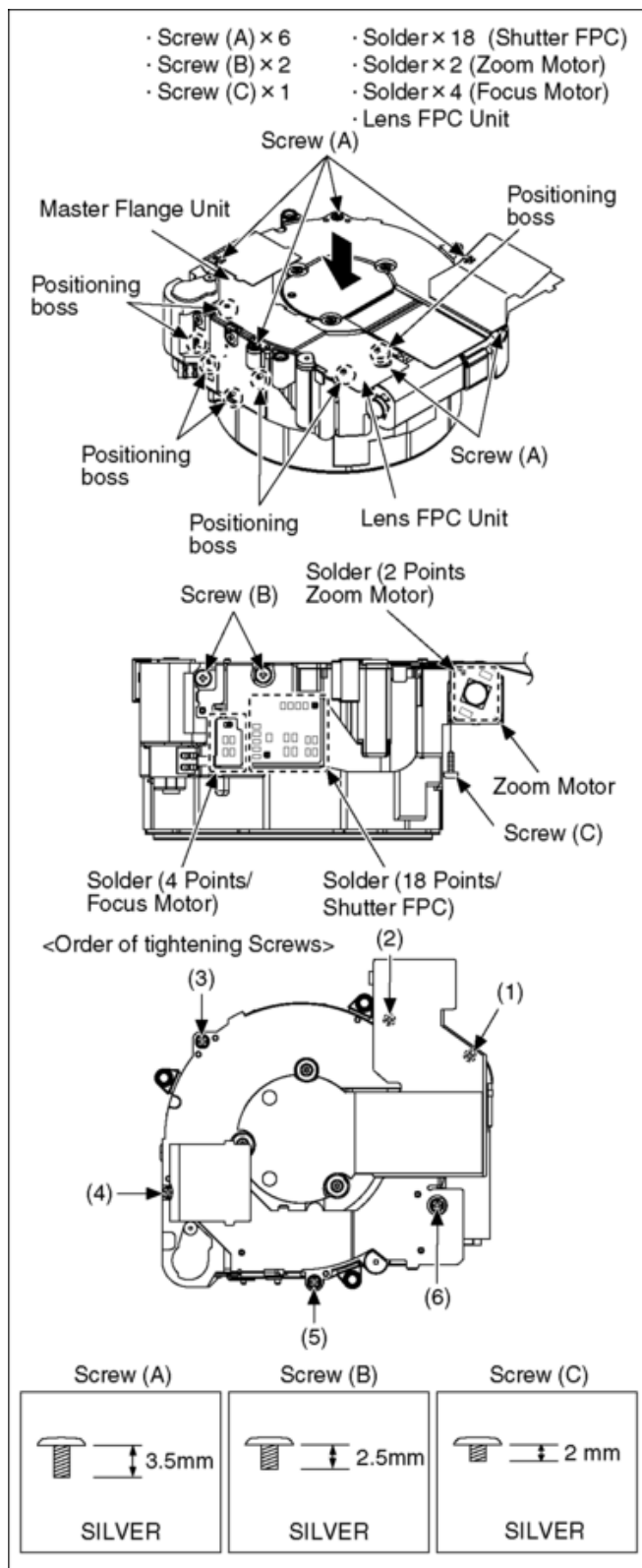

9.6 Removal of the MOS Unit

When remove the MOS Unit once (the Torx screw (A) is loosened even a little), the optical tilt adjustment is required.
 When loosen the Torx screw (A), necessary the optical tilt adjustment at the end of assembling. (Refer to item "10.3.2.")
 To prevent the MOS Unit from catching the dust and dirt, do not remove the MOS Unit except for replacing.

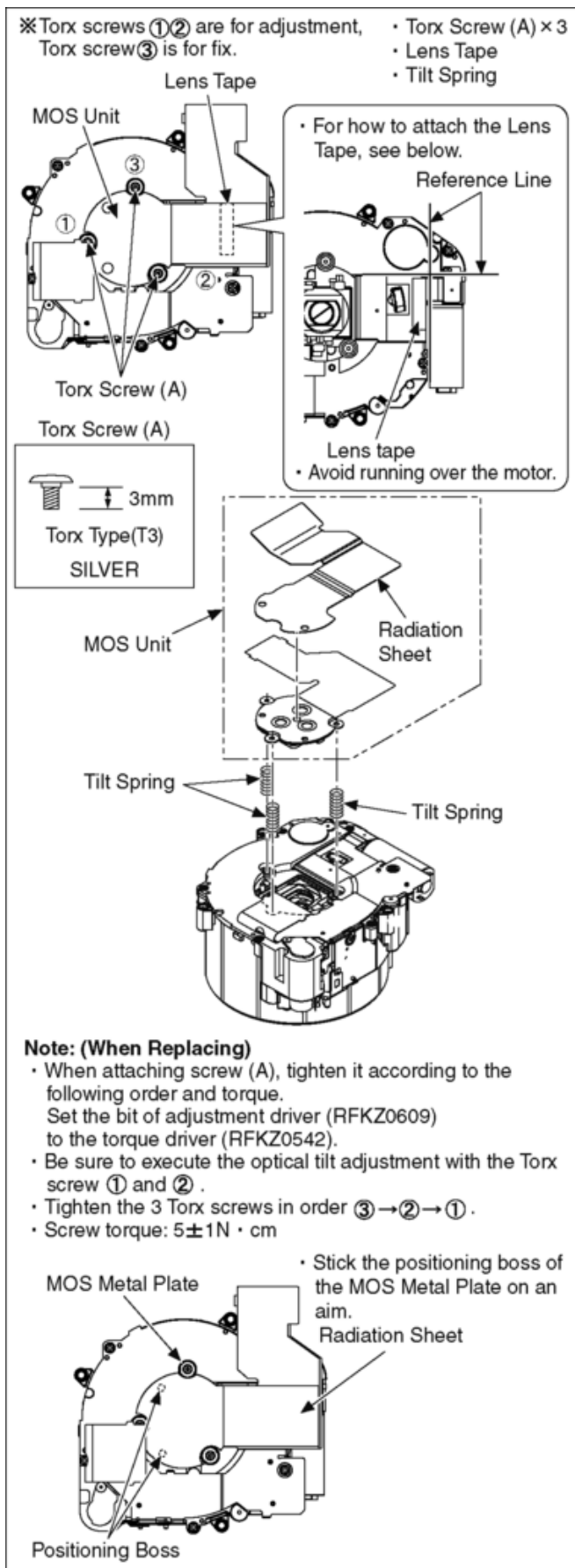

10 Measurements and Adjustments

10.1 Introduction

When servicing this unit, make sure to perform the adjustments necessary based on the part(s) replaced.

When trouble occurs, it is recommended to backup the Flash-rom data before disassembling the unit.

NOTICE: (When replacing the Lens unit, Master flange unit and MOS unit)

- When the MOS unit is unavoidably removed for Lens unit, Master flange unit and MOS unit replaced, an optical adjustment is necessary after parts are exchanged.
- It is necessary to use the "DSC_Tilt" software to allow the "Optical tilt adjustment".
- The Adjustment software "DSC_Tilt" is available at "TSN Website".

NOTICE (When replacing the Flash ROM(IC6003) or Charging Control Microcomputer(IC1502))

When the Flash Rom or Charging Control Microcomputer is replaced, it is need to adjust the firmware of the Charging Control Microcomputer to the one of the Flash ROM.

For details, refer to "10.3.2. Adjustment Specifications".

It may takes about 10 seconds. While doing the adjustment, don't turn the power off forcibly.

(It cause the Charging Control Microcomputer crush, then the camera can not turn on.)

NOTICE (When replacing the Main P.C.B.)

Number of necessary adjustment items decreases by copying the backup data to new Main P.C.B. when adjustment data in old Main P.C.B. can be read by ROM_BACKUP "DSC→SD" in "10.2.2. Flash-Rom Data Backup ". For more details, please refer an item "MAIN PCB (to which the backup data was copied)" in the table of "10.3.2. Adjustment Specifications ".

IMPORTANT NOTICE (After replacing the Main P.C.B.)

After replacing the Main P.C.B., it is necessary to achieve adjustment.

10.2 Before Disassembling the unit

10.2.1 Initial Setting Release

The cameras specification are initially set in accordance with model suffix (such as EB, EG, GK, GC, and so on.).

Unless the initial setting is not released, an automatic alignment software in the camera is not able to be executed when the alignment is carried out.

Note:

The initial setting should be again done after completing the alignment. Otherwise, the camera may not work properly.

Therefore as a warning, the camera display a warning symbol " ! " on the LCD monitor every time the camera is turned off.

Refer to the procedure described in "3.5.2. INITIAL SETTINGS" for details.

[How to Release the camera initial setting]

Preparation:

Attach the fully charged Battery, and insert the memory card (32MB or more).

Set the recording mode dial to **PROGRAM AE** mode.

Step 1. Temporary cancellation of "INITIAL SETTINGS":

While pressing the **RIGHT** of Cursor button", **MENU/SET** button and **DISPLAY** button simultaneously, turn the Power on.

Step 2. Cancellation of "INITIAL SETTINGS":

Press **PLAYBACK** button to switch to the playback screen. (Keep pressing the button.)

Press "**UP**" of Cursor button" additionally.

Turn the Power off. (The warning symbol " ! " is displayed on the LCD monitor.)



10.2.2 Flash-Rom Data Backup

Number of necessary adjustment items decreases by copying the backup data to new Main P.C.B. when adjustment data in old Main P.C.B. can be read by ROM_BACKUP "DSC→SD".

It is recommended to backup the Flash-rom data as the way of return when trouble occurs before disassembling the unit depending on each case.

[ROM_BACKUP (Method of Non-PC backup)]

1. Insert the Memory Card into the camera.

- Set the camera to "Temporary cancellation of the initial settings".
- Select the "SETUP" menu.
From the "SETUP" menu, select "ROM BACKUP".

Note:

This item is not listed on the customer's "SET UP" menu.

- When this "ROM_BACKUP" item is selected, the following submenus are displayed.



Item	Function	Details
DSC → SD	Save all the DSC's Flash-rom data to Memory Card	<ul style="list-style-type: none"> DSC's Flash-rom data is saved to the Memory Card as a data file. (DATA BACKUP) File location: ROOT DIRECTORY in Memory Card. File Name: <ol style="list-style-type: none"> User Setup Information data: <Model No.>U.txt [Depending on the model, more than one file may be generated (e.g. <Model No.>U.TXT and <Model No.>U3.TXT).] Electrical Adjustment data: <Model No.>F.txt [Depending on the model, more than one file may be generated (e.g. <Model No.>F.TXT and <Model No.>F3.TXT).] If the concerned file already exists, "OVERWRITE?" message is displayed.
SDALL → DSC (ID CHECK)	Write the all data to DSC's Flash-rom from Memory Card	<ul style="list-style-type: none"> The backup data stored in the Memory Card is transferred to DSC unit. ID CHECK: When the model ID is different, data is not transferred. FORCE: Even if the model ID is different, data is transferred. * If the main PCB is replaced, select "SDALL → DSC(FORCE)".
SDALL → DSC (FORCE)	Write the all data to DSC's Flash-rom from Memory Card	
SDUSER → DSC (FORCE)	Only "User setup information" is written from the saved file in the Memory Card to DSC's Flash-rom.	<ul style="list-style-type: none"> Only the user's "setup" setting condition is transferred to DSC unit. FORCE: Even if the model ID is different, the data is transferred.
I → LUMIX	Shipping set without initializing "User setup information"	<ul style="list-style-type: none"> Initial setting is executed without initializing the user's set up setting condition. * The initial setting must be performed while the Self-timer LED is blinking. * The picture data stored in the built-in memory of the DSC is not erased, with this operation.
ADJFLAG → ALL F	Set all adjustment flags completion	<ul style="list-style-type: none"> Status of the all adjustment flags are changed to "F"(completion).
WBADJ → STEPMODE	ISO: Adjustment WBL, WBM: Setting	<ul style="list-style-type: none"> ISO: Sensitivity adjustment. WBL: Setting up the white in low color temperature. WBM: Setting up the white in high color temperature.
STEPMODE → WBADJ	Cancel "STEPMODE"	<ul style="list-style-type: none"> Cancel the "STEPMODE" mode.

10.2.3 About Light Box

How to remove the Front Hood

In order to utilize maximum of the diffusing surface of light box, some adjustment items need the distance between diffusing surface of light box and camera body becomes several cent-meters.

Before the adjustments, remove the front hood of light box following steps below.

[For RFKZ0523 Light Box]

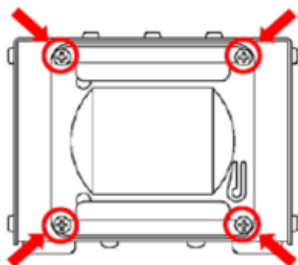

Unscrew the 4 screws, then remove the front hood.

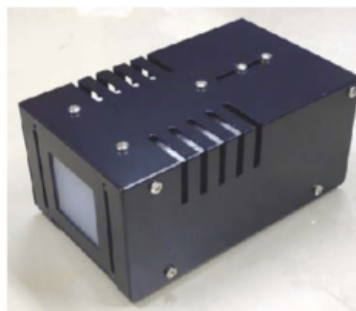

10.3 Details of Electrical Adjustment

10.3.1 How to execute the Electrical Adjustment

It is not necessary to connect the camera to a PC to perform adjustments.

"Flag reset operation" and "Initial setting operation" are required when carrying out the alignment, follow the procedure below.

10.3.1.1 Startup Electrical Adjustment mode

- Release the initial settings.
- Insert a recordable Memory Card (32MB or more).
(Without a Memory Card, the automatic adjustment can not executed.)

3. Procedure to set the camera into adjustment mode:
 1. Set the mode dial to **PROGRAM AE** mode.
 2. Turn the Power off.
 3. While pressing the "**LEFT**" of Cursor button" and **MENU/SET** button simultaneously, turn the Power on. LCD monitor displays "SERVICE MODE".
(Refer to Fig.F3-1)

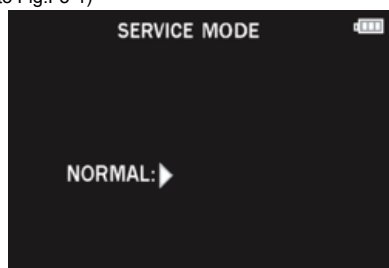

Fig. 3-1

10.3.1.2 Status Adjustment Flag Setting

Reset (Not yet adjusted) the status flag condition.

1. After pressing the **DISPLAY** button, the LCD monitor displays the Flag status screen (Refer to Fig.3-2.)
2. Select item by pressing the Cursor buttons. (Gray cursor is moved accordingly.)
3. Press the **DELETE** button.

Note:

The selected item's flag has been changed from

"F (green)" to "0 (yellow)".

*Flag conditions:

F (green)

means that the alignment has been completed and the status flag condition is set. In this case, the flag condition should be reset, if you try to carry out the automatic alignment.

0 (yellow)

means that the alignment has been not "completed" and the status flag condition is "reset". In this case, automatic alignment is available.



Fig. 3-2

- To display the "BK2" flag, choose the "WNZ" and press the **DOWN** of Cursor button.
- In case of setting the status flag into set condition again without completion of the alignment, the status flag should be SET by using PC, or UNDO by using ROM BACKUP function.

10.3.1.3 Execute Adjustment

1. Perform step "10.3.1.1." to "10.3.1.2.", to reset the OIS flag status "F" (Set) to "0" (Reset).
2. Press **DISPLAY** button after Flag reset.
OIS Adjustment screen is displayed on the LCD panel. (Refer to Fig.3-3)
3. Press the shutter button. The adjustment will start automatically.

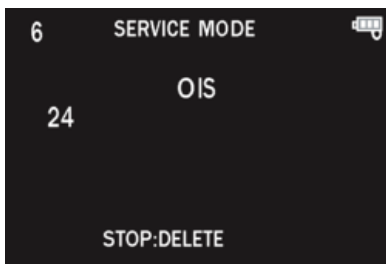

Fig. 3-3

4. When the adjustment is completed successfully, adjustment report menu appears with Green OK on the LCD monitor. (Refer to Fig.3-4)

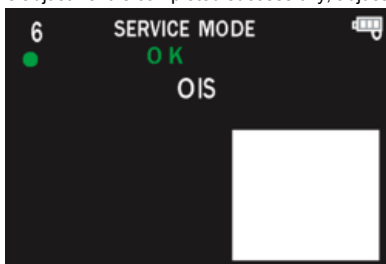

Fig. 3-4

10.3.1.4 Attention point during Adjustment

1. Step "10.3.1.3." procedure shows OIS adjustment as an example. To perform the adjustment, refer to the "10.3.2. Adjustment Specifications" table which shows key point for each adjustment.
2. Do not move the light box, the camera or the chart while adjusting. If one of these is moved accidentally, start the adjustment again.
3. Do not press any buttons/keys until the default menu (Fig.3-5) is displayed on the LCD monitor. Otherwise, adjustment data may not be stored properly.
4. If the adjustment is interrupted accidentally, the alignment data may not be properly saved in the Flash-ROM.

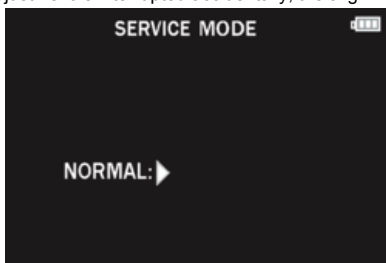

Fig. 3-5

10.3.1.5 Finalizing the Adjustment

1. Several adjustment flags can be reset ("F" into "0") at the same time. In this case, when the adjustment has been completed, the screen will change showing the adjustment for the next item until all reset items are completed.
Also, when the shutter button is pressed, the screen jump to the next adjustment item.
2. To cancel the adjustment mode while in the process of performing the adjustment, follow this procedures.
 - (1) Press "DISPLAY" button.
 - (2) Press "RIGHT" of Cursor button".

Note:

*.If adjustment is cancelled with above procedure, adjustment is not completed. Make sure to adjust it later.



10.3.2 Adjustment Specifications

The following matrix table shows the relation between the replaced part and the Necessary Adjustment.

When a part is replaced, make sure to perform the necessary adjustment(s) in the order indicated.

The table below shows all the information necessary to perform each adjustment.

Adjustment order	Adjustment Item	FLAG	Purpose	Replacing Parts							JIG/TOOLS	SET UP	How to Operate		
				MAIN P.C.B./VENUS ENGINE	MAIN P.C.B. (When written Backup data)	Flash-ROM (IC6003)	Charging Control Microcomputer (IC1502)	Lens Part (Excluding Image Sensor)	Image Sensor	Microphone				Flash Part	Electronic Level (IC6201)
1	Synchronization of Flash-ROM with the charge control micro computer	—	Executing synchronization (optimization) of Flash-ROM with the charge control micro computer (Upgrading the software version)	—	—	○	○	—	—	—	—	—	—	<ul style="list-style-type: none"> Do adjust the firmware of the Charging Control Microcomputer to the firmware of the one of the Flash ROM by the following procedure. <ol style="list-style-type: none"> Release the camera initial setting. Insert a memory card (32MB or more). Turn the power off. The camera check the firmware of both the Flash ROM and the Charging Control Microcomputer. If they are not match, the firmware of the Charging Control Microcomputer is updated and the camera is turned the power off automatically. <p>*While doing adjustment, don't turn the power off forcibly.</p> It takes about 10 seconds to update the firmware of the Charging Control Microcomputer. While updating, the camera is displaying a warning symbol "I" on the LCD and lighting the AF Assist Lamp. (If the firmware of the camera(Flash ROM) is old, the AF Assist Lamp does not light.) 	
2	Optical Tilt	—	Adjustment of MOS Unit installation angle to the Lens	—	—	—	○	○	—	—	—	—	—	<p>Note: It is necessary to use the "DSC_Tilt" software to allow the "Optical tilt adjustment". The Adjustment software "DSC_Tilt" is available at "TSN Website".</p> <ul style="list-style-type: none"> Optical Tilt Adjustment Chart RFKZ0570 Optical Tilt Adjustment Driver RFKZ0609: T3 Camera Stand RFKZ0333J Torque Driver RFKZ0542 	
3	Zoom Home Position	ZHP	Zoom Home Position inspection	—	—	○	—	○	○	—	—	—	NONE	NONE	<ol style="list-style-type: none"> Change the flag into the "0", and then proceed to the adjustment mode. Press the shutter button fully. (When a result is OK, it is the completion of an inspection.)
4	Venus Zoom *4	PZM	Venus Zoom inspection	○	○	○	—	—	—	—	—	—	NONE	NONE	<ol style="list-style-type: none"> Change the flag into the "0", and then proceed to the adjustment mode. Press the shutter button fully. (When a result is OK, it is the completion of an inspection.)
5	OIS sensor	OIS	OIS sensor output level adjustment	○	—	○	—	○	○	—	—	—	NONE	NONE	<ol style="list-style-type: none"> Change the flag into the "0", and then proceed to the adjustment mode. Press the shutter button fully. (When a result is OK, it is the completion of an inspection.)
6	Backfocus / GYRO *4	BF	To have the focus tracking curve be appropriate shape and GYRO sensor adjustment	○	○	○	—	○	○	*1	—	—	○	—	<ul style="list-style-type: none"> Collimator RFKZ0422 <ol style="list-style-type: none"> Set the camera in front of collimator so that the distance between collimator and camera body becomes 7.5 cm as shown in Fig. A. (It is not distance between lens barrel top and diffusing surface of light box.) * Set the camera on a tripod to prevent it from falling down. <ol style="list-style-type: none"> Change the flag into the "0", and then proceed to the adjustment mode. Set the camera angle so that the star chart is displayed to the center, and press the shutter button fully. (Green mark is displayed on LCD.) Press the shutter button fully, again. (When a result is OK, it is the completion of an inspection.)
7	Iris	IRS	Iris adjustment	○	—	○	—	○	○	—	—	—	○	—	<ul style="list-style-type: none"> Light Box RFKZ0523 <ol style="list-style-type: none"> Set the camera in front of light box so that the distance between diffusing surface of light box and camera body becomes 5.0 cm as shown in Fig. B. (It is not distance between lens barrel top and diffusing surface of light box.) <ol style="list-style-type: none"> Change the flag into the "0", and then proceed to the adjustment mode. Set the camera angle so that the diffusing surface of light box is displayed on the full of LCD monitor, and press the shutter button fully. (When a result is OK, it is the completion of an inspection.)
8	Shutter	SHTS	Shutter speed adjustment	○	—	○	—	○	○	—	—	—	○	—	<ul style="list-style-type: none"> Light Box RFKZ0523 <ol style="list-style-type: none"> Set the camera in front of light box so that the distance between diffusing surface of light box and camera body becomes 5.0 cm as shown in Fig. B. (It is not distance between lens barrel top and diffusing surface of light box.) <ol style="list-style-type: none"> Change the flag into the "0", and then proceed to the adjustment mode. Set the camera angle so that the diffusing surface of light box is displayed on the center of LCD monitor, and press the shutter button fully. (When a result is OK, it is the completion of an inspection.)
		SHD	Do not use "SHD" adjustment flag for this unit. Use "BK2" adjustment flag, instead.												

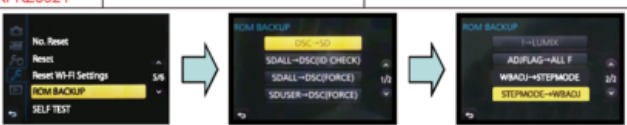
Adjustment order	Adjustment Item	FLAG	Purpose	Replacing Parts										JIG/TOOLS	SET UP	How to Operate			
				MAIN P.C.B./VENUS ENGINE	MAIN P.C.B. (When written Backup data)	Flash-ROM (IC6003)	Charging Control Microcomputer (IC1502)	Lens Part (Excluding Image Sensor)	Image Sensor	Microphone	Flash Part	Electronic Level (IC6201)	Eye Sensor						
<p>• Set "STEPMODE" to adjust 7: ISO, 8: WBL and 9: WBM. <How to switch to "STEPMODE"> 1. Perform "10.2.2. Flash-ROM Data Backup", and select "WBADJ → STEPMODE" for ROM_BACKUP. 2. Press "SET", and move to the flag setting screen at "STEPMODE". ⇒ The screen appears on the LCD. (See Fig. on the right.)</p>																			
<p style="text-align: center;">Normal flag setting screen</p>  <p style="text-align: right;">[STEPMODE] flag setting screen</p> 																			
9	ISO	ISO	ISO sensitivity adjustment	○	○	○	○	○	○	○	○	○	○	○	○	○	<ul style="list-style-type: none"> Light Box RFKZ0523 ND0.3 Filter RFKZ0513 	1) Set the camera in front of light box so that the distance between diffusing surface of light box and camera body becomes 5.0 cm as shown in Fig. B. (It is not distance between lens barrel top and diffusing surface of light box.)	1) Change the flag into the "0", and then proceed to the adjustment mode. 2) Set the camera angle so that the diffusing surface of light box is displayed on the center of LCD monitor, and press the shutter button fully. (When a result is OK, it is the completion of an inspection.)
10	White balance (Low color temp.)	WBL	Setting up the white in low color temperature	○	○	○	○	○	○	○	○	○	○	○	○	○	<ul style="list-style-type: none"> Light Box RFKZ0523 ND0.9 Filter VFK1164ND09 ND0.3 Filter RFKZ0513 CC-C7.5 Filter RFKZ0511 	1) Set the camera in front of light box so that the distance between diffusing surface of light box and camera body becomes 5.0 cm as shown in Fig. B. (It is not distance between lens barrel top and diffusing surface of light box.)	1) Change the flag into the "0", and then proceed to the adjustment mode. 2) Set the camera angle so that the diffusing surface of light box is displayed on the center of LCD monitor, and press the shutter button fully. (When a result is OK, it is the completion of an inspection.)
11	White balance (High color temp.)	WBM	Setting up the white in high color temperature	○	○	○	○	○	○	○	○	○	○	○	○	○	<ul style="list-style-type: none"> Light Box RFKZ0523 ND0.9 Filter VFK1164ND09 ND0.3 Filter RFKZ0513 CC-C7.5 Filter RFKZ0511 CC-Y10 Filter RFKZ0512 LBB2 Filter RFKZ0520 LBB8 Filter RFKZ0521 	1) Set the camera in front of light box so that the distance between diffusing surface of light box and camera body becomes 5.0 cm as shown in Fig. B. (It is not distance between lens barrel top and diffusing surface of light box.)	1) Change the flag into the "0", and then proceed to the adjustment mode. 2) Set the camera angle so that the diffusing surface of light box is displayed on the center of LCD monitor, and press the shutter button fully. (When a result is OK, it is the completion of an inspection.)
<p>• After adjusting 7: ISO, 8: WBL and 9: WBM, perform Initial Settings once. Then, cancel "STEPMODE". <How to release of "STEPMODE"> • Perform "10.2.2. Flash-ROM Data Backup", and select "STEPMODE → WBADJ" for ROM_BACKUP. Press "SET". Then again, cancel the Initial Settings. Move to the servicing mode, and continue the subsequent adjustment.</p>																			
																			
12	Offset gain	SAT	Setting up the offset gain	○	○	○	○	○	○	○	○	○	○	○	○	○	<ul style="list-style-type: none"> Light Box RFKZ0523 ND0.6 Filter VFK1164ND06 	1) Set the ND0.6 filter to diffusing surface of light box. 2) Set the camera in front of light box so that the distance between diffusing surface of light box and camera body becomes 5.0 cm as shown in Fig. B.	1) Change the flag into the "0", and then proceed to the adjustment mode. 2) Set the camera angle so that what is displayed on the LCD monitor fully, and press the shutter button fully. (When a result is OK, it is the completion of an inspection.)
13	Eye sensor	EYE	Inspecting sensitivity of eye sensor	○	○	○	○	○	○	○	○	○	○	○	○	○	<ul style="list-style-type: none"> Gray Card RFKZ0506 	1) Set the camera in front of gray card so that the distance between gray card and eye sensor of camera body becomes 5.5 cm as shown in Fig. C.	1) Change the flag into the "0", and then proceed to the adjustment mode. 2) Set the camera angle so that the attachment side of eye sensor and center of the gray card is perpendicular, and press the shutter button fully. (When a result is OK, it is the completion of an inspection.)
14	Flash adjustment *4	STB	Flash adjustment	○	○	○	○	○	○	○	○	○	○	○	○	○	NONE	NONE	1) Change the flag into the "0", and then proceed to the adjustment mode. 2) Press the shutter button fully. 3) Check that a flash shines. (It is different for every model how many times it shines.) * When a flash does not shine, there is a possibility that the flash unit is out of order. 4) Check a test result. * Results of the tests are usually NG. (When a result is OK, it is the completion of an inspection.) 5) When a result is NG, rewrite STB flag to an adjustment using ADJFLAG → ALL F of ROM BACKUP . * The flag "STB" is an item which checks shines operation of a flash automatically at a Manufacturing facility. For this reason, except environment for exclusive use, a result will be NG. but it is no problem if shines operation can be checked visually.

Adjustment order	Adjustment Item	FLAG	Purpose	Replacing Parts								JIG/TOOLS	SET UP	How to Operate		
				MAIN P.C.B./VENUS ENGINE	MAIN P.C.B. (When written Backup data)	Flash-ROM (IC6003)	Charging Control Microcomputer (IC1502)	Lens Part (Excluding Image Sensor)	Image Sensor	Microphone	Flash Part				Electronic Level (IC8201)	Eye Sensor
15	MOS sensor Temp. white missing pixels *2	SKI	Registration of the Temp. white missing pixels	O	-	O	-	O	-	-	-	-	NONE	NONE	1) Change the flag into the "0", and then proceed to the adjustment mode. 2) Press the shutter button fully. (When a result is OK, it is the completion of an inspection.)	
16	MOS sensor FD white missing pixels *2	WKI	Registration of the FD (floating diffusion) white missing pixels	O	-	O	-	O	O	*1	-	-	-	NONE	NONE	1) Change the flag into the "0", and then proceed to the adjustment mode. 2) Press the shutter button fully. (When a result is OK, it is the completion of an inspection.)
BKI Do not use "BK1" adjustment flag for this unit. Use "BK2" adjustment flag, instead. (In case of most DSC models, the adjustment flag for MOS SENSOR Missing Pixels is "BK1". But, in this model, "BK2" the adjustment flag for MOS SENSOR Missing Pixels.)																
17	Color reproduction inspection Microphone check	COL	Color reproduction inspection and Microphone check	O	-	O	-	O	O	O	-	-	-	NONE	NONE	1) Change the flag into the "0", and then proceed to the adjustment mode. 2) Press the shutter button fully. 3) Utter the voice for about 5 seconds into the microphone, just before pushing a shutter release. * Utter the voice at the above the MIC. * Comparatively high voice is ideal. (Standard: about 1KHz) (When a result is OK, it is the completion of an inspection.)
18	Linear adjustment	OLN	Linear adjustment	O	-	O	-	O	-	-	-	-	-	* Linear Adjustment Chart Download the "Linear Adjustment chart .pdf" and print it by the actual size. ("Linear Adjustment chart .pdf" is available at "TSN Website". (Fig. 1) To download, click on "Support information from NWBG/VDBG -AVC") * Black Bar length: 55 mm	NONE	1) Change the flag into the "0", and then proceed to the adjustment mode. 2) Press the shutter button fully. Error occurs, but zoom position becomes "Tele". ("720" is displayed on left center of the LCD screen.) (Fig. 2) 3) Clear the error flag, and then proceed to the adjustment mode. (Press the delete button. → Press the display button, then the flag status screen is displayed. → Select "OLN" by pressing the cursor button. → Press the delete button. → Press the display button, then adjustment screen is displayed.) 4) Set the camera so that the distance between the lens and the linear adjustment chart becomes 200 cm as shown in Fig. 3. *Adjust the height and position of the camera to keep the middle black bar in the guide for adjustable of view angle. 5) While keeping "Tele" zoom position (confirm "720" display), press the shutter button fully. (When a result is OK, it is the completion of an inspection.) *If "720" is not displayed, do procedure from 2) to 4) again.

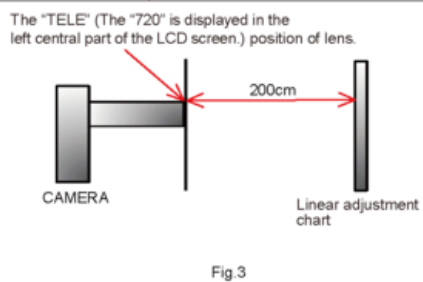
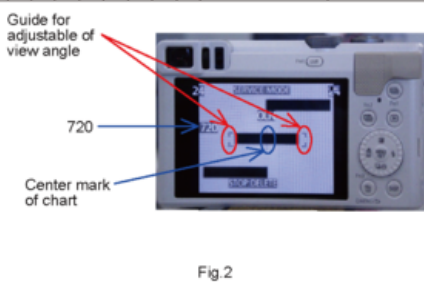
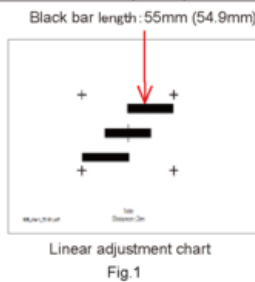

Adjustment order	Adjustment Item	FLAG	Purpose	Replacing Parts							JIG/TOOLS	SET UP	How to Operate	
				MAIN P.C.B./VENUS ENGINE	MAIN P.C.B. (When written Backup data)	Flash-ROM (IC6003)	Charging Control Microcomputer (IC1502)	Lens Part (Excluding Image Sensor)	Image Sensor	Microphone				Flash Part
19	Electronic Level	AA2 + AA3	Electronic Level adjustment	○	○	○	-	-	-	-	○	-	<p>1) Download the "ACC Adjustment chart .pdf" and print it to A3 size (or equivalent size) paper. ("ACC Adjustment chart .pdf" is available at "TSN Website". To download, click on "Support information from NWBG/VDBG-AVC")</p> <p>2) Hang in the string with weight, then put the printed ACC adjustment chart on the wall or panel horizontally. (Fig. 4)</p> <p>* After putting the adjustment chart horizontally, remove the string with weight.</p> <p>* Attach the camera to tripod.</p> <p><Setup procedures></p> <p>3-1) Adjust the height of tripod to match the lens of camera and center of the adjustment chart.</p> <p>3-2) Apply the triangle (or equivalent) in center of the chart, then adjust center of the lens of camera on the vertical extension.</p> <p>3-3) Confirm that the chart is displayed on the LCD monitor fully.</p> <p>3-4) Fine adjust the camera angle so that the horizontal bar of chart is displayed horizontally on the LCD monitor and matches the cross guide line of the LCD monitor. (Fig. 5)</p>	<p>1) Change the flag "AA2" and "AA3" into the "0", and then press DISPLAY button and proceed to the adjustment mode.</p> <p><Offset adjustment></p> <p>2) Set the camera to the horizontal position. Then set the distance between adjustment chart and camera body becomes 29 cm. And optical axis of the lens and center of the chart crosses right-angled. (Fig. 6)</p> <p>3) Press the shutter button fully. (When a result is OK, it is the completion of an inspection.)</p> <p><Tilt adjustment></p> <p>4) Rotate the camera to the 90 degrees, so that the grip side down, and press the shutter button. (Fig. 7)</p> <p>5) Set the camera to the horizontal position, and press the shutter button. (Fig. 8)</p> <p>6) Rotate the camera to the 90 degrees, so that the grip side up, and press the shutter button. (Fig. 9) (When a result is OK, it is the completion of an inspection.)</p>
<div style="display: flex; justify-content: space-between;"> <div style="width: 20%;"> <p>Fig.4: Setting of the adjustment chart horizontally</p> <p>Fix by pins (or equivalent)</p> <p>Install the adjustment chart so that the both marking top and bottom of chart overlaps with the string.</p> <p>Hung string with weight</p> </div> <div style="width: 20%;"> <p>Fig.5: Setting of the camera to the front of adjustment chart</p> <p>[Top View]</p> <p>Triangle</p> <p>ACC Adjustment chart</p> <p>CAMERA</p> </div> <div style="width: 15%;"> <p>Fig.6: [Offset] (Horizontal Position)</p> </div> <div style="width: 15%;"> <p>Fig.7: [Vertical Position] (Grip side Down)</p> </div> <div style="width: 15%;"> <p>Fig.8: [Horizontal Position]</p> </div> <div style="width: 15%;"> <p>Fig.9: [Vertical Position] (Grip side Up)</p> </div> </div>														
20	Shading Compensation and MOS SENSOR Missing Pixels (Black) *3	BK2	Compensation of Shading and Compensation of MOS SENSOR Missing Pixels (Black)	○	○	○	○	1	-	-	-	<p>* Light Box RFKZ0523</p> <p>* Diffuser RFKZ0591</p>	<p>1) Set the Diffuser to diffusing surface of light box.</p>	<p>1) Change the flag into the "0", and then proceed to the adjustment mode. (BK2 flag is 2nd pages.)</p> <p>2) Press the shutter button fully. → Green ● mark is displayed on LCD.</p> <p>3) Attach the Camera Lens on the Diffuser. And set the camera angle so that the diffusing surface of light box is displayed on the full of LCD monitor, and press the shutter button fully. → The 1st adjustment is executed, and then Green ● mark is displayed on LCD.</p> <p>4) Separate the camera body from light box, and press the shutter button fully. → The lens starts zooming and stops automatically, then green ● mark is displayed on LCD.</p> <p>5) Attach the Camera Lens on the Diffuser. And set the camera angle so that the diffusing surface of light box is displayed on the full of LCD monitor, and press the shutter button fully. → The 2nd adjustment is executed, and then Green ● mark is displayed on LCD.</p> <p>6) Separate the camera body from light box, and press the shutter button fully. → The lens starts zooming and stops automatically, then green ● mark is displayed on LCD.</p> <p>7) Attach the Camera Lens on the Diffuser. And set the camera angle so that the diffusing surface of light box is displayed on the full of LCD monitor, and press the shutter button fully. → The 3rd adjustment is executed. When a result is OK, it is the completion of an inspection.</p>
	Wi-Fi check	WiFi	Do not use "WiFi" adjustment flag for servicing. This adjustment is for factory procedure. (For confirmation of Wi-Fi function, use the reception of Wi-Fi access point as usual.)											

*1: This adjustment must be performed not only replacing the MOS unit, but also simply removing the MOS unit.

*2: The pixel that always lights while shaded is called a white wound.

*3: The pixel that does not light while complete exposed is called a black wound. This unit does not have the LCD adjustment of the camera (LCD flicker adjustment etc.).

*4: If the adjusted data is backed up from the main board before replacement or repair, write the data to the new main board. If parts other than the main board are not replaced, adjustment is not necessary for items other than "Venus Zoom(PZM)/Backfocus/GYRO(BF)/Flash(STB)".

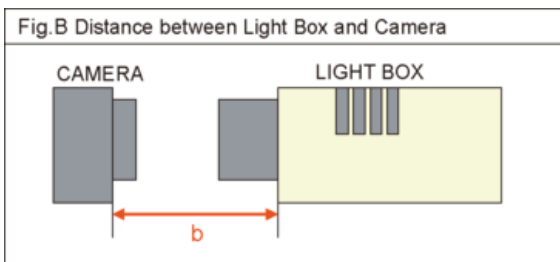
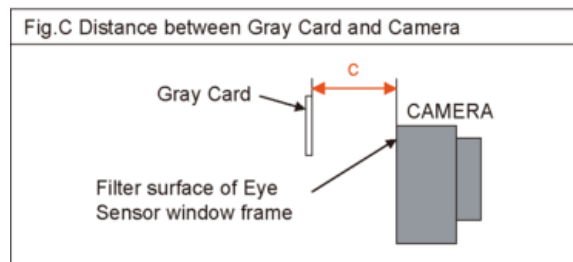
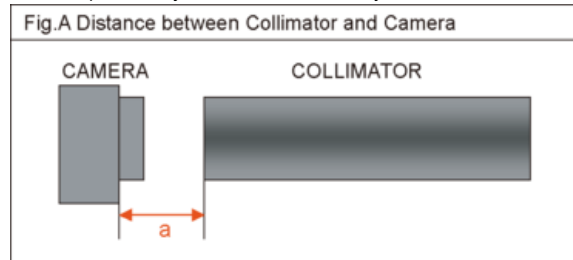

■ IMPORTANT NOTICE (After replacing the Main P.C.B.)

After replacing the Main P.C.B., make sure to perform the "INITIAL SETTINGS" first, then release the "INITIAL SETTINGS" in order to proceed the electrical adjustment.

Note:

1. If electrical adjustment or data re-writing is executed before "INITIAL SETTINGS", suffix code list is never displayed, and it cannot be chosen suitable suffix code.
2. Never remove the battery during initial setting in process.

10.4 After Adjustment

10.4.1 Initial Setting

Since the initial setting has been released to execute the built-in adjustment software, it should be set up again before shipping the camera to the customer. Refer to the procedure described in "3.5.2. INITIAL SETTINGS" for details.

[IMPORTANT]

1. The initial setting should be done again after completing the alignment. Otherwise, the camera will not work properly. Therefore as a warning, the camera display a warning symbol " ! " on the LCD monitor every time the camera is turned off.
2. Confirm that status of all adjustment flag show "F". Even if one of the adjustment flag shows "0", initial setting programmed is never executed.

11 Maintenance

11.1 Cleaning Lens, Viewfinder and LCD Panel

Do not touch the surface of lens, Viewfinder and LCD Panel with your hand.

When cleaning the lens, use air-Blower to blow off the dust.

When cleaning the LCD Panel, dampen the lens cleaning paper with lens cleaner, and the gently wipe the their surface.

Note:

The Lens Cleaning KIT; VFK1900BK(Only supplied as 10 set/Box) is available as Service Aid.

Model No. : DMC-TZ80/TZ81/ZS60 Schematic Diagram Note

IMPORTANT SAFETY NOTICE:

COMPONENTS IDENTIFIED WITH THE MARK  HAVE THE SPECIAL CHARACTERISTICS FOR SAFETY. WHEN REPLACING ANY OF THESE COMPONENTS USE ONLY THE SAME TYPE.

1. Although reference number of the parts is indicated on the P.C.B. drawing and/or schematic diagrams, it is NOT mounted on the P.C.B. when it is displayed with "\$" mark.
2. It is only the "Test Round" and no terminal (Pin) is available on the P.C.B. when the TP (Test Point) indicated as "●" mark.
3. Use the parts number indicated on the Replacement Parts List .
4. Indication on Schematic diagrams:

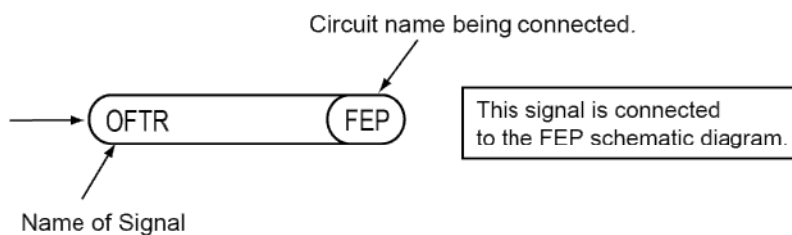

5. It might be taking time for display and/or access of the Schematic Diagrams & P. C. B having the heavy data volume.

Model No. : DMC-TZ80/TZ81/ZS60 Parts List Note

- Note:
1. * Be sure to make your orders of replacement parts according to this list.
 2. **IMPORTANT SAFETY NOTICE**
Components identified with the mark \triangle have the special characteristics for safety.
When replacing any of these components, use only the same type.
 3. Unless otherwise specified,
All resistors are in OHMS, K=1,000 OHMS. All capacitors are in MICRO-FARADS (uf), P=uuF.
 4. The marking (RTL) indicates the retention time is limited for this item. After the discontinuation of this assembly in production, it will no longer be available.
 5. Supply of CD-ROM, in accordance with license protection, is allowable as replacement parts only for customers who accidentally damaged or lost their own.

E.S.D. standards for Electrostatically Sensitive Devices, refer to PREVENTION OF ELECTROSTATIC DISCHARGE (ESD) TO ELECTROSTATICALLY SENSITIVE (ES) DEVICES section.

Definition of Parts supplier:

1. **Parts marked with [INBD] in the remarks column are supplied from INBD.
Others are supplied from PAVCX.**

Model No. : DMC-TZ80/TZ81/ZS60 Power (P) (Main P.C.B.)

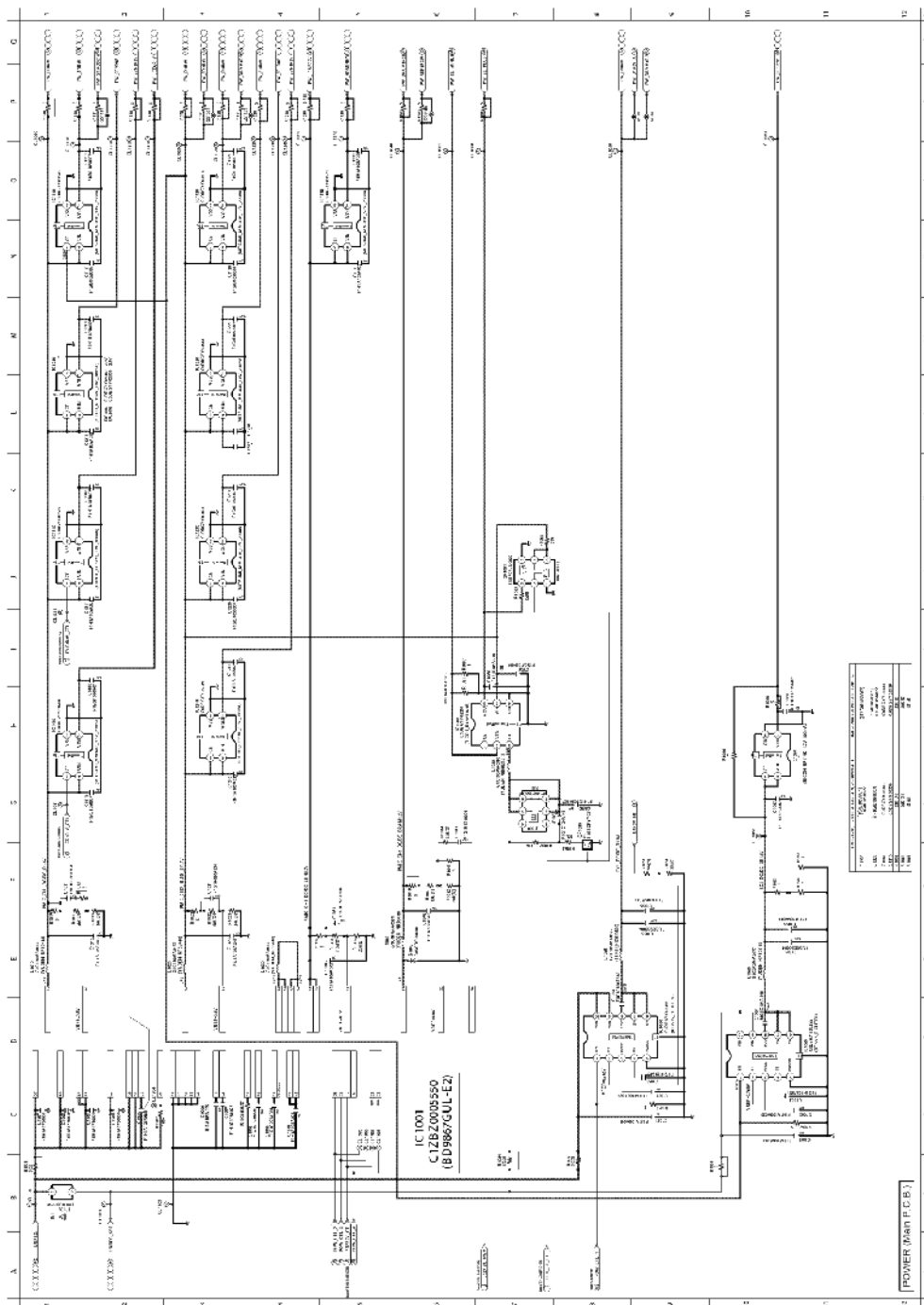

Model No. : DMC-TZ80/TZ81/ZS60 USB Charge (U) (Main P.C.B.)

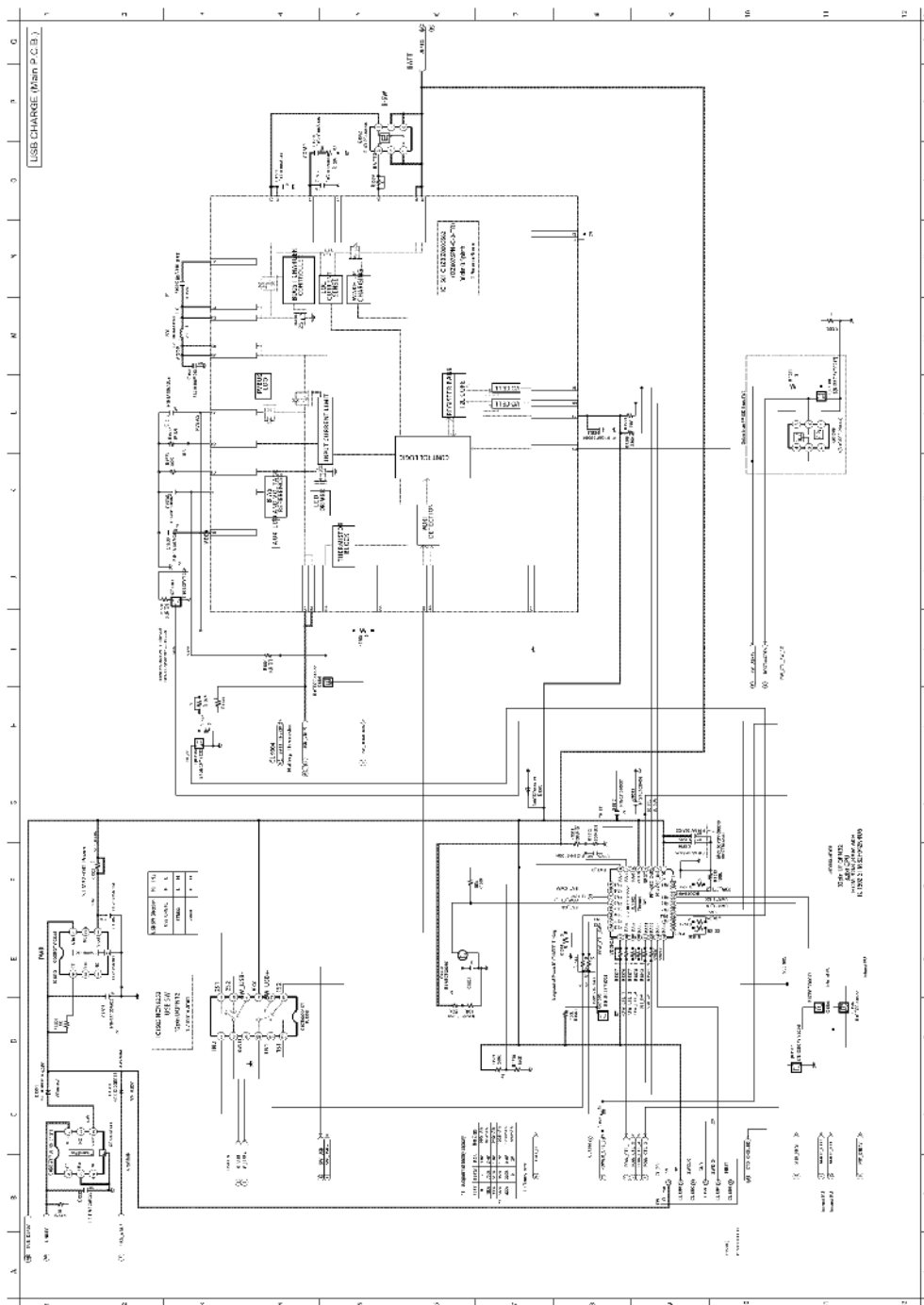

Model No. : DMC-TZ80/TZ81/ZS60 Jack (J) (Main P.C.B.)

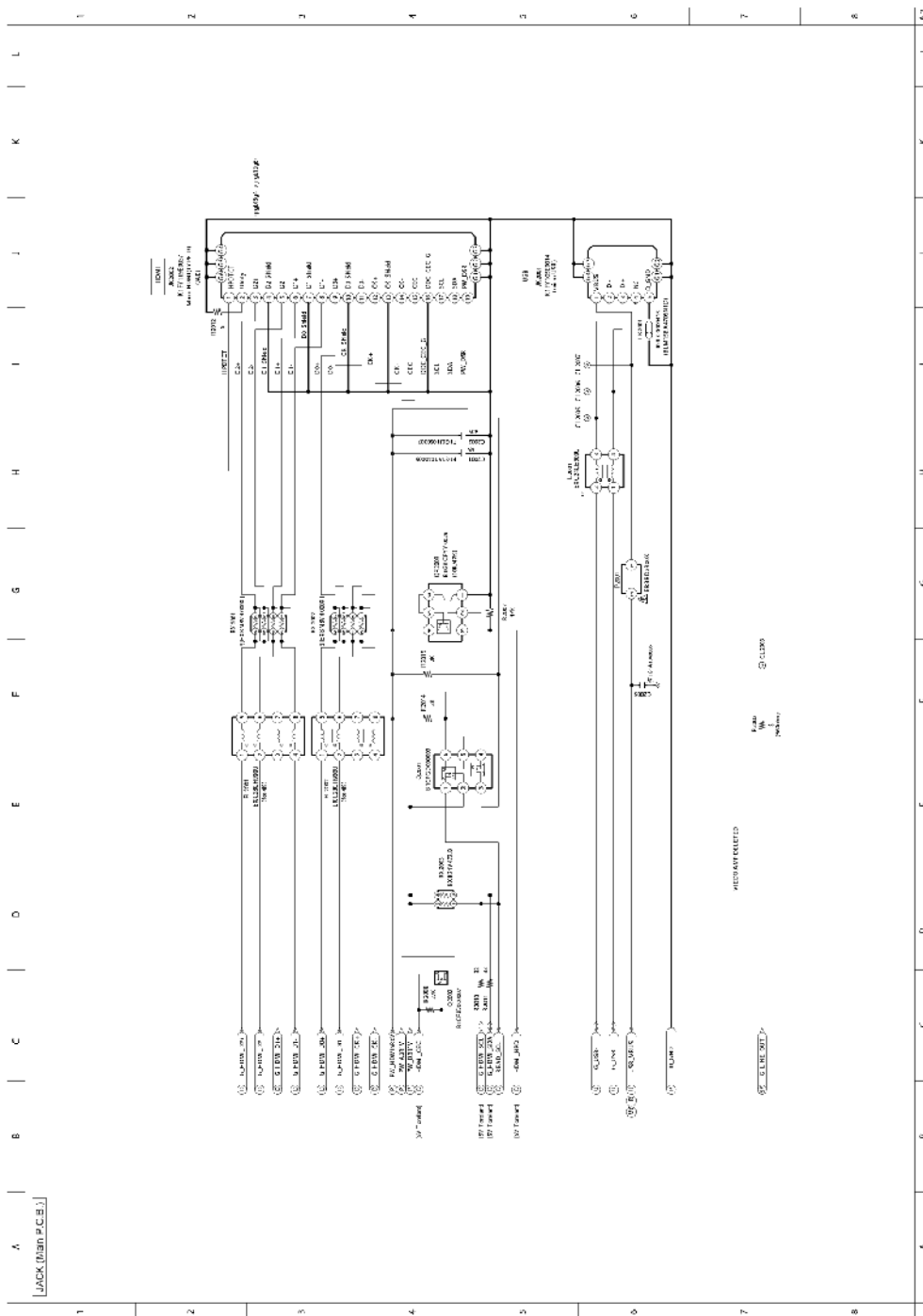

Model No. : DMC-TZ80/TZ81/ZS60 LCD (L) (Main P.C.B.)

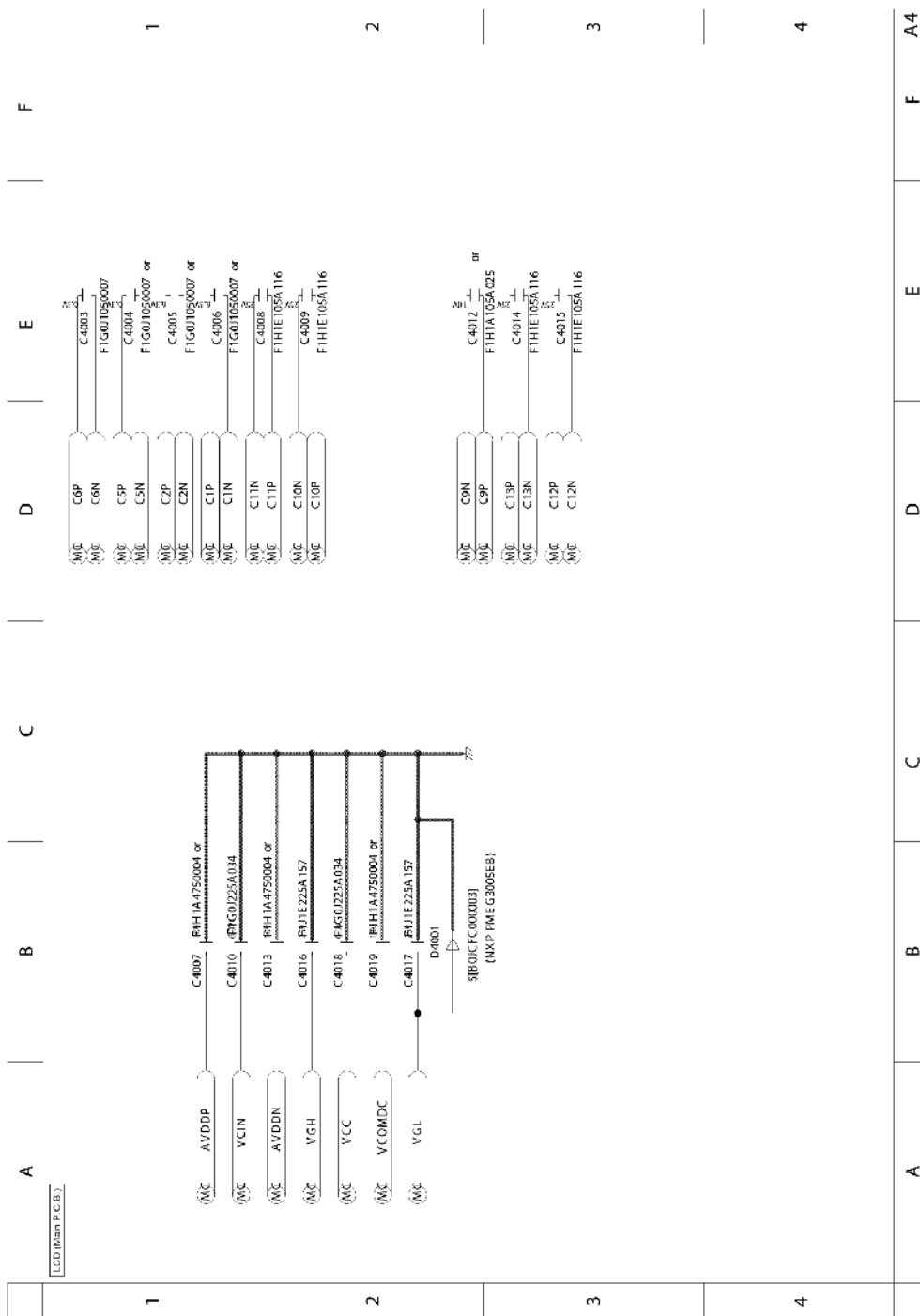

Model No. : DMC-TZ80/TZ81/ZS60 Digital (D) (Main P.C.B.)

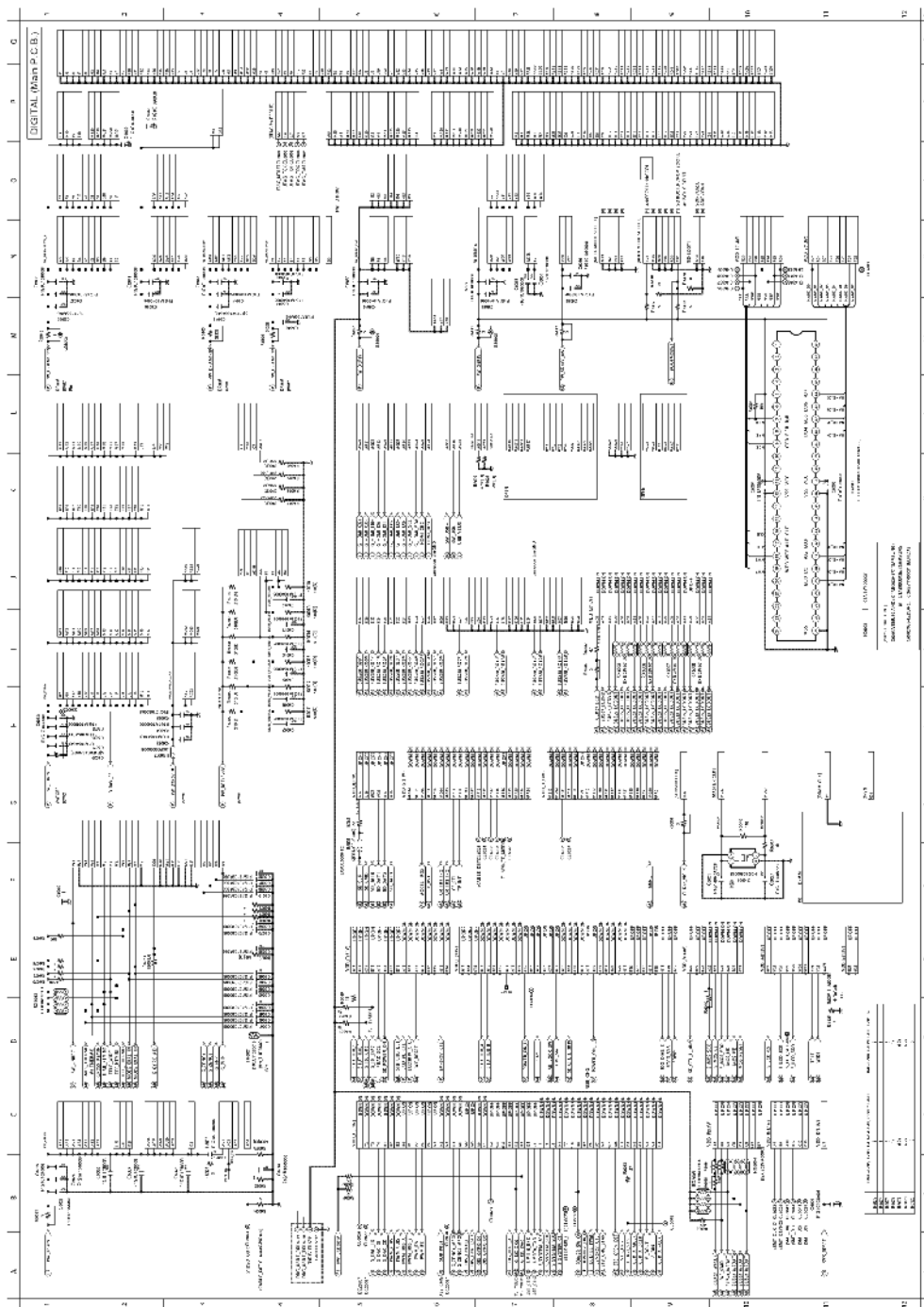

Model No. : DMC-TZ80/TZ81/ZS60 Acceleration (AC) (Main P.C.B.)

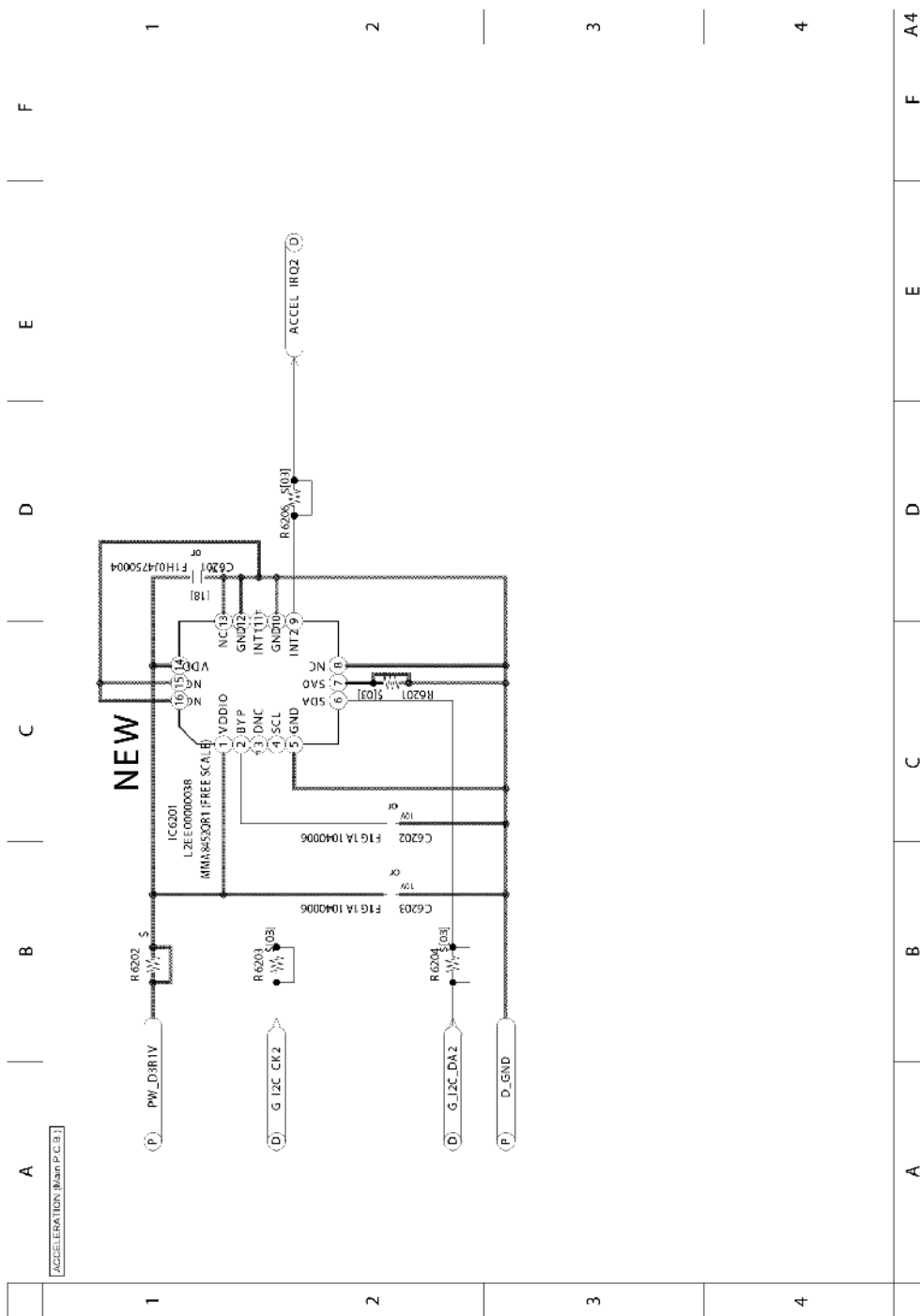

Model No. : DMC-TZ80/TZ81/ZS60 Gyro (GY) (Main P.C.B.)

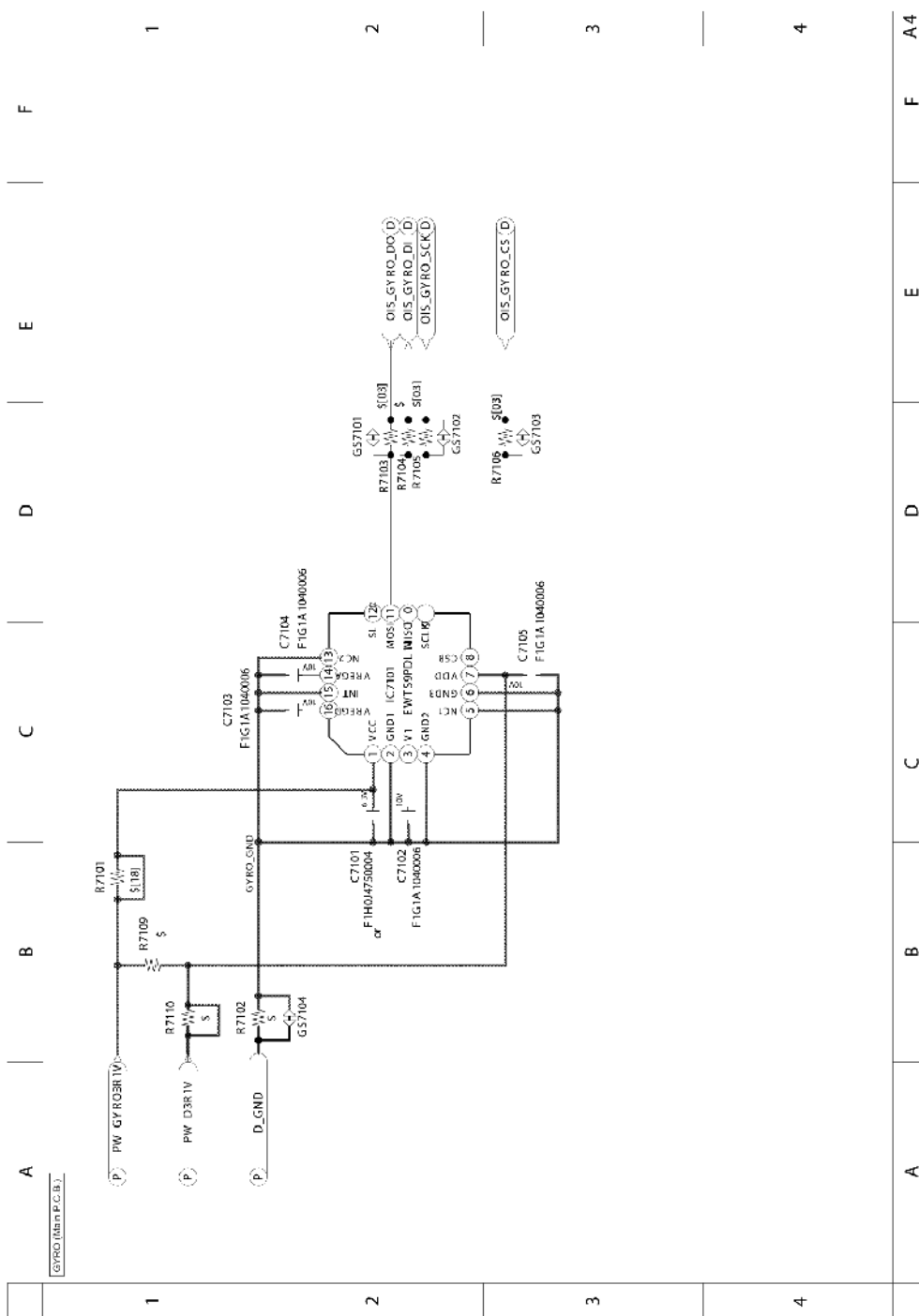

Model No. : DMC-TZ80/TZ81/ZS60 System Driver (SY) (Main P.C.B.)

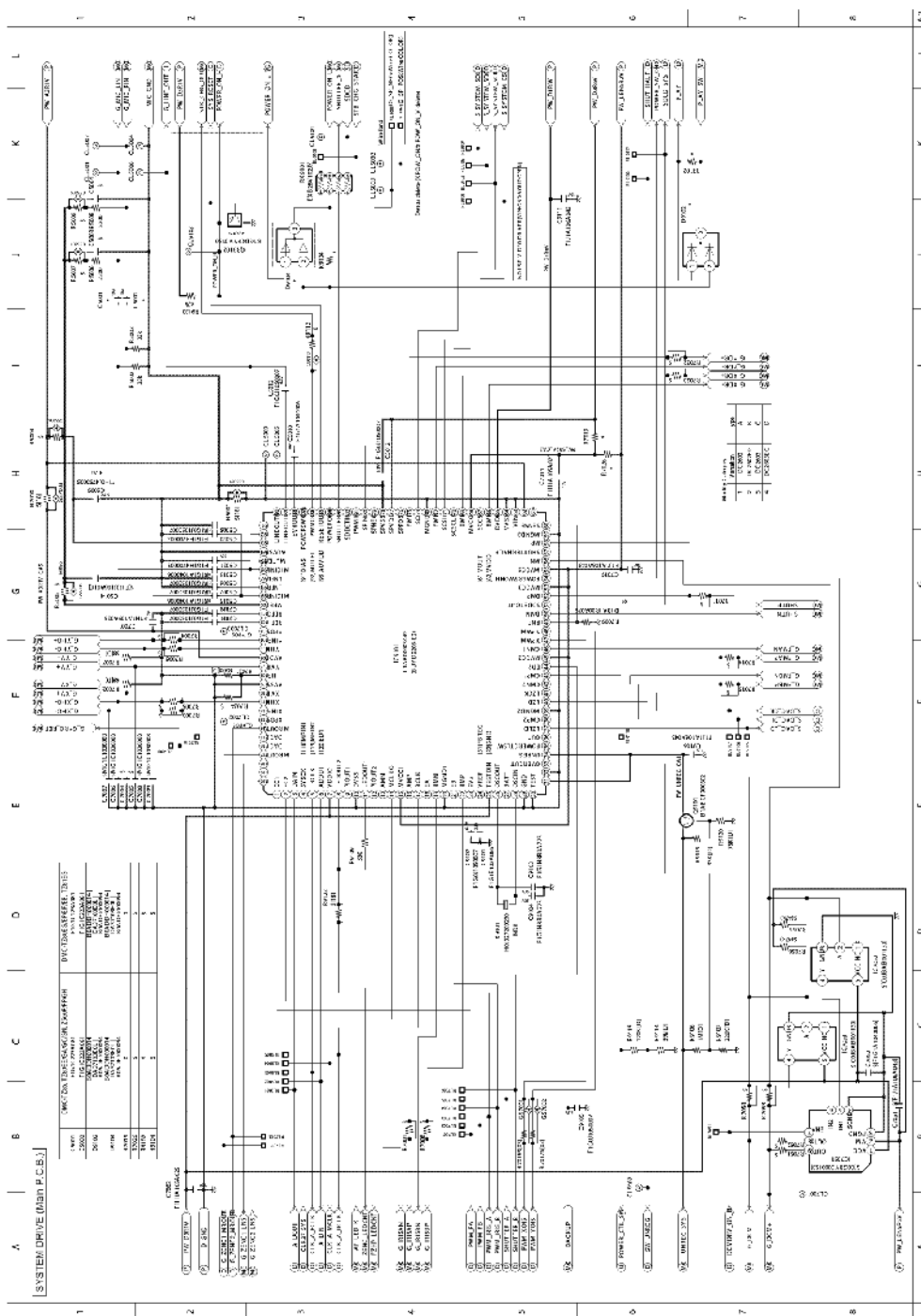

Model No. : DMC-TZ80/TZ81/ZS60 Top (TP) (Top P.C.B.)

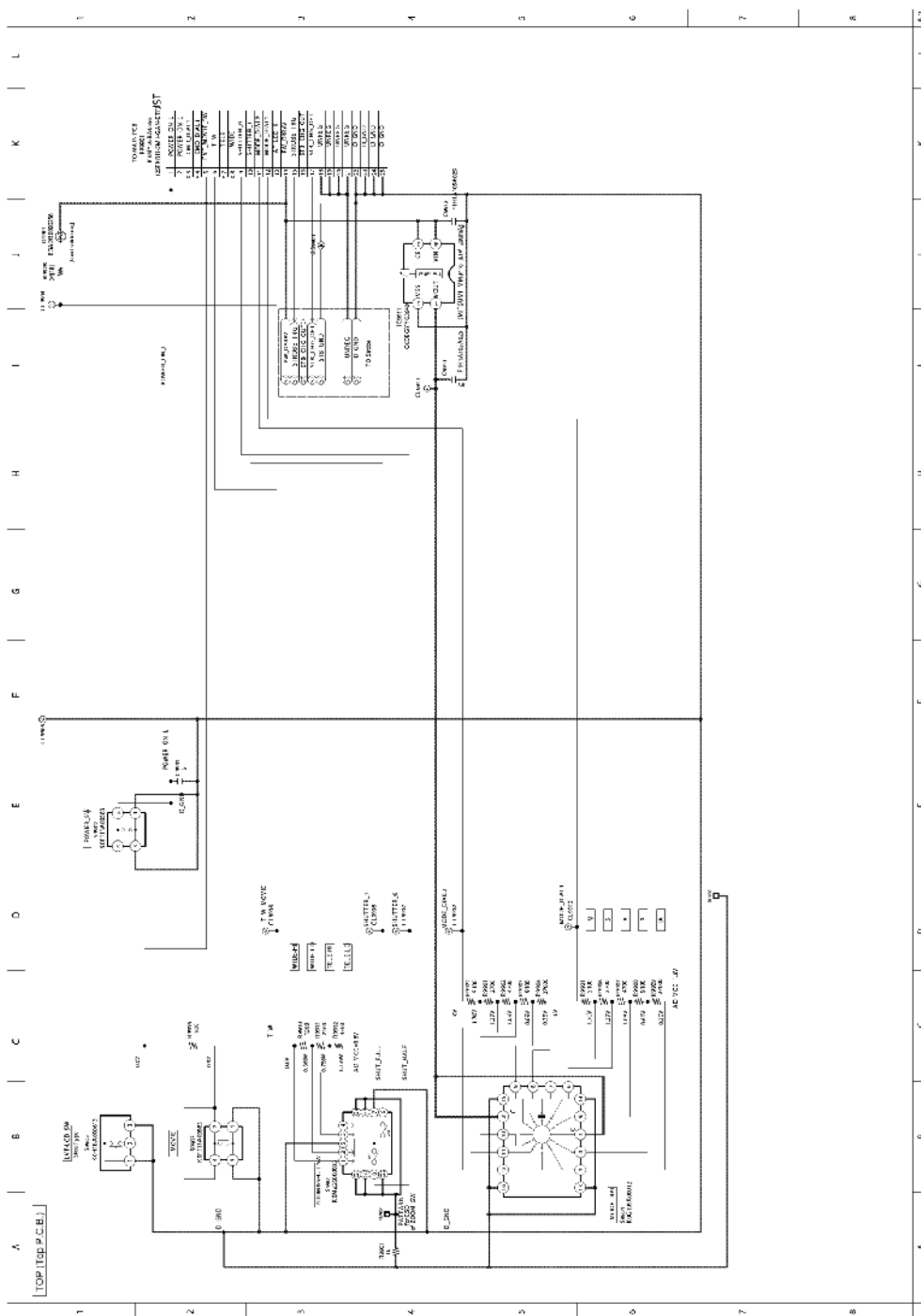

Model No. : DMC-TZ80/TZ81/ZS60 Battery (Battery P.C.B.)

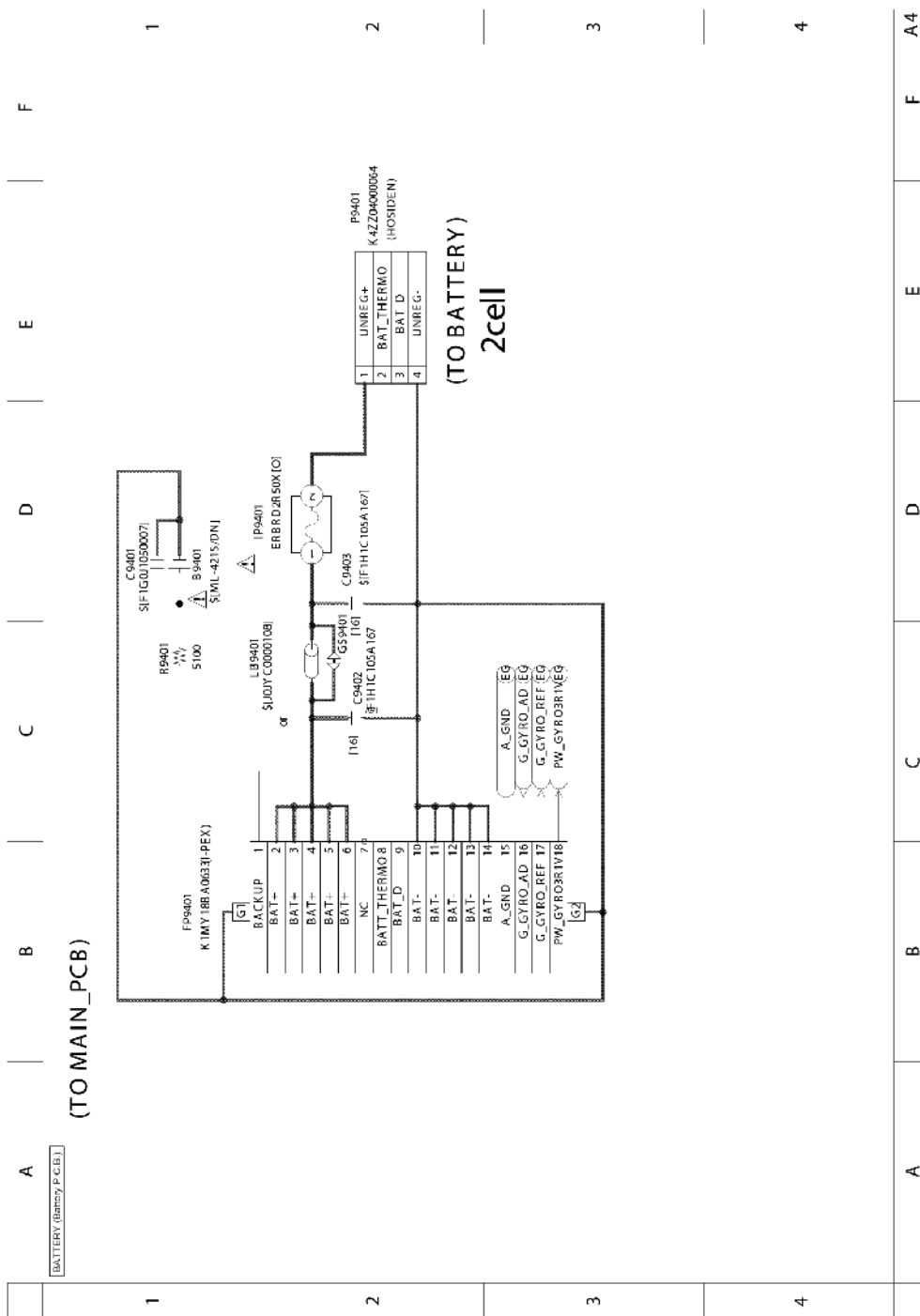

Model No. : DMC-TZ80/TZ81/ZS60 EX Gyro (EG) (Battery P.C.B.)

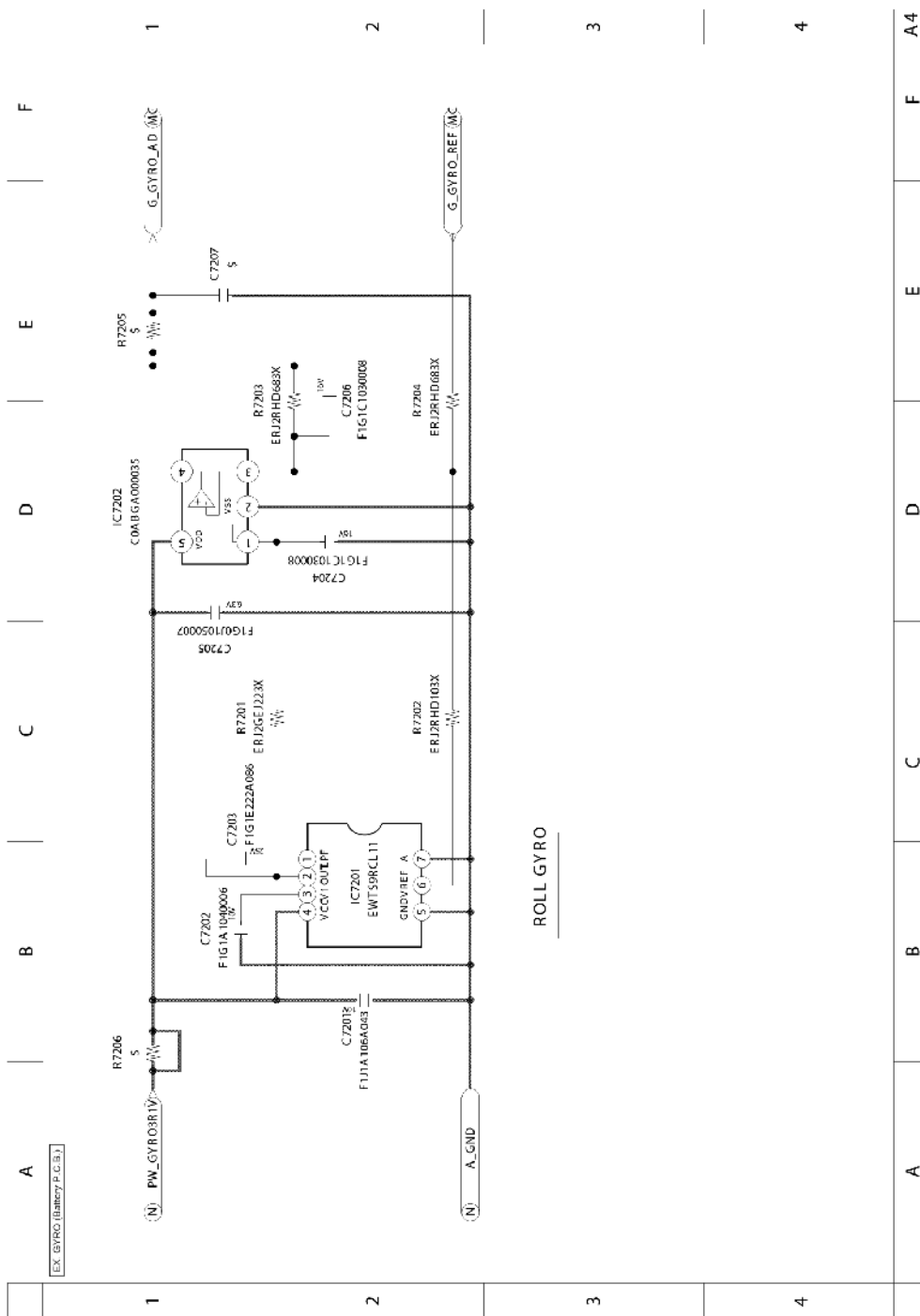

Model No. : DMC-TZ80/TZ81/ZS60 Lens Flex (Lens Flex P.C.B.)

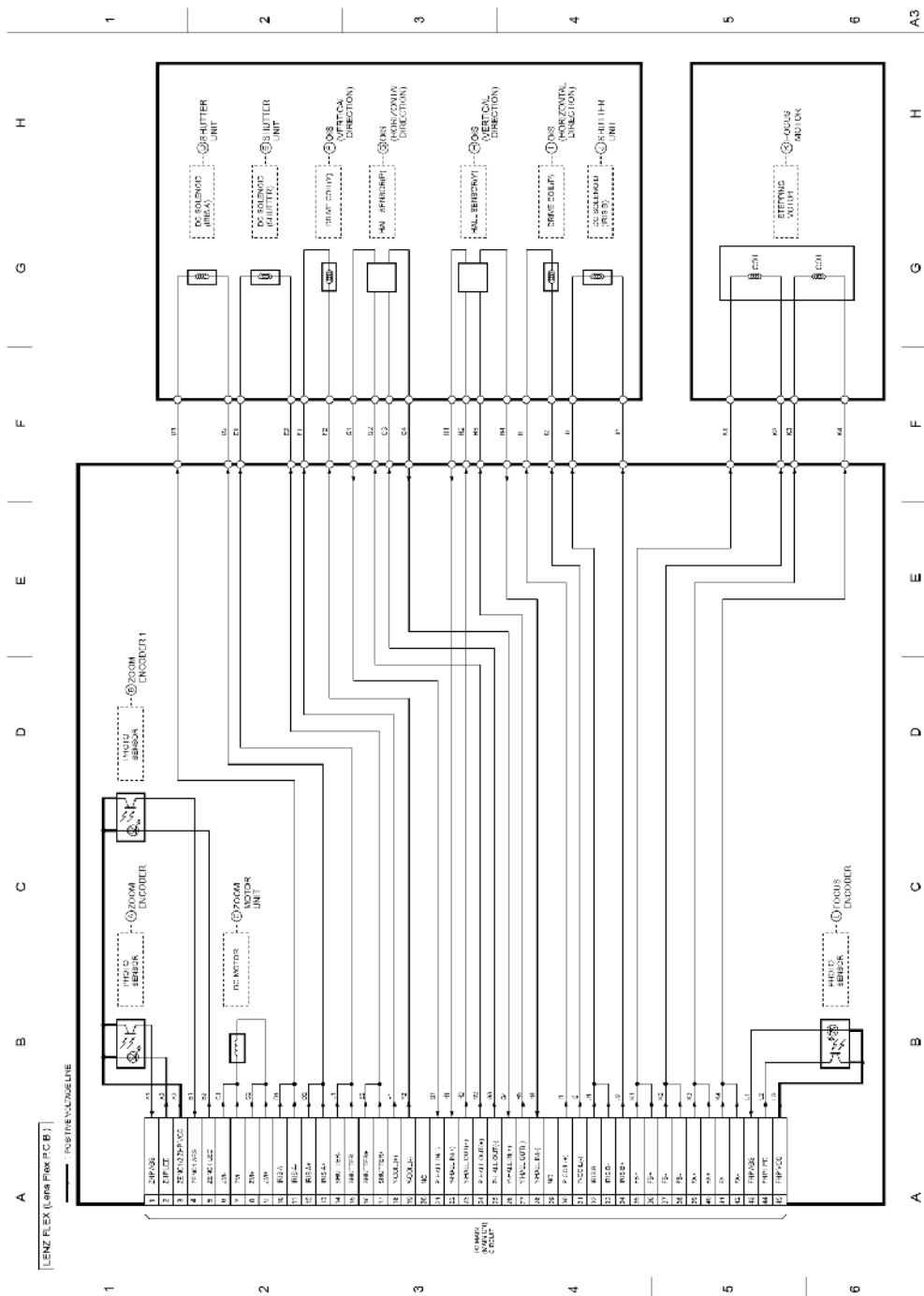

Model No. : DMC-TZ80/TZ81/ZS60 Main P.C.B. (Component Side)

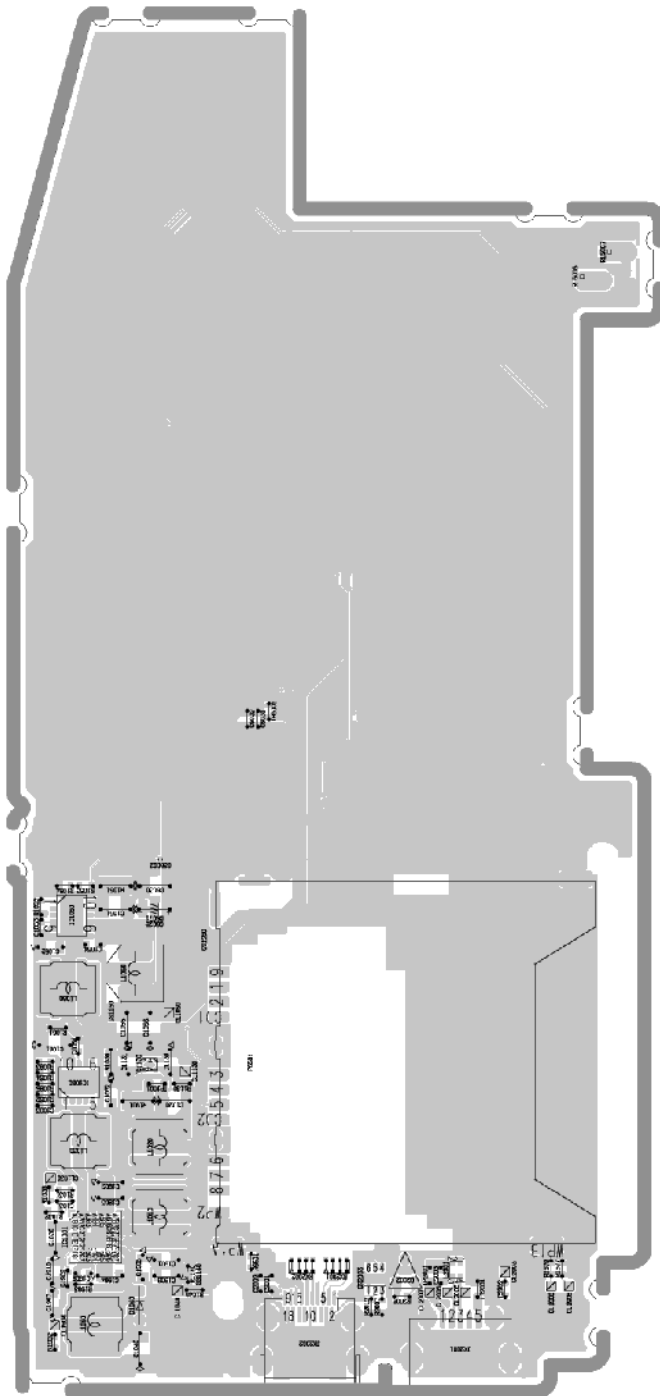

Model No. : DMC-TZ80/TZ81/ZS60 Main P.C.B. (Foil Side)

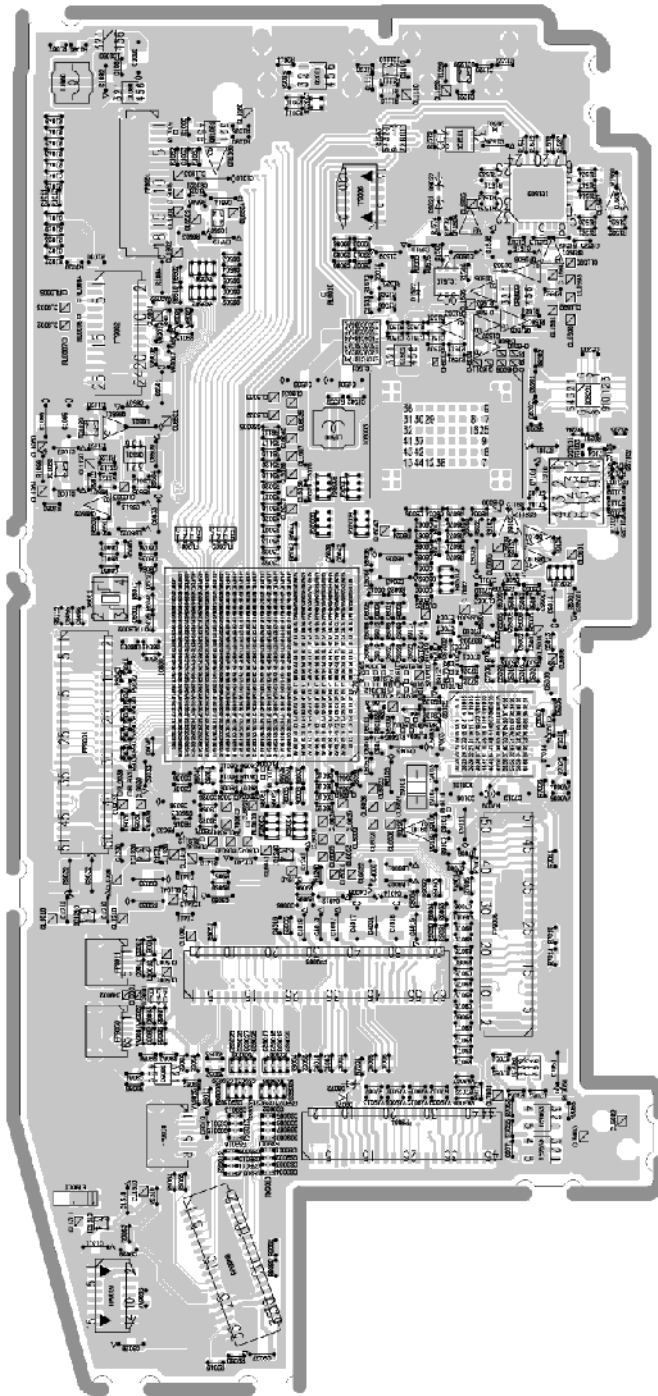

Model No. : DMC-TZ80/TZ81/ZS60 Battery P.C.B. (Component Side)

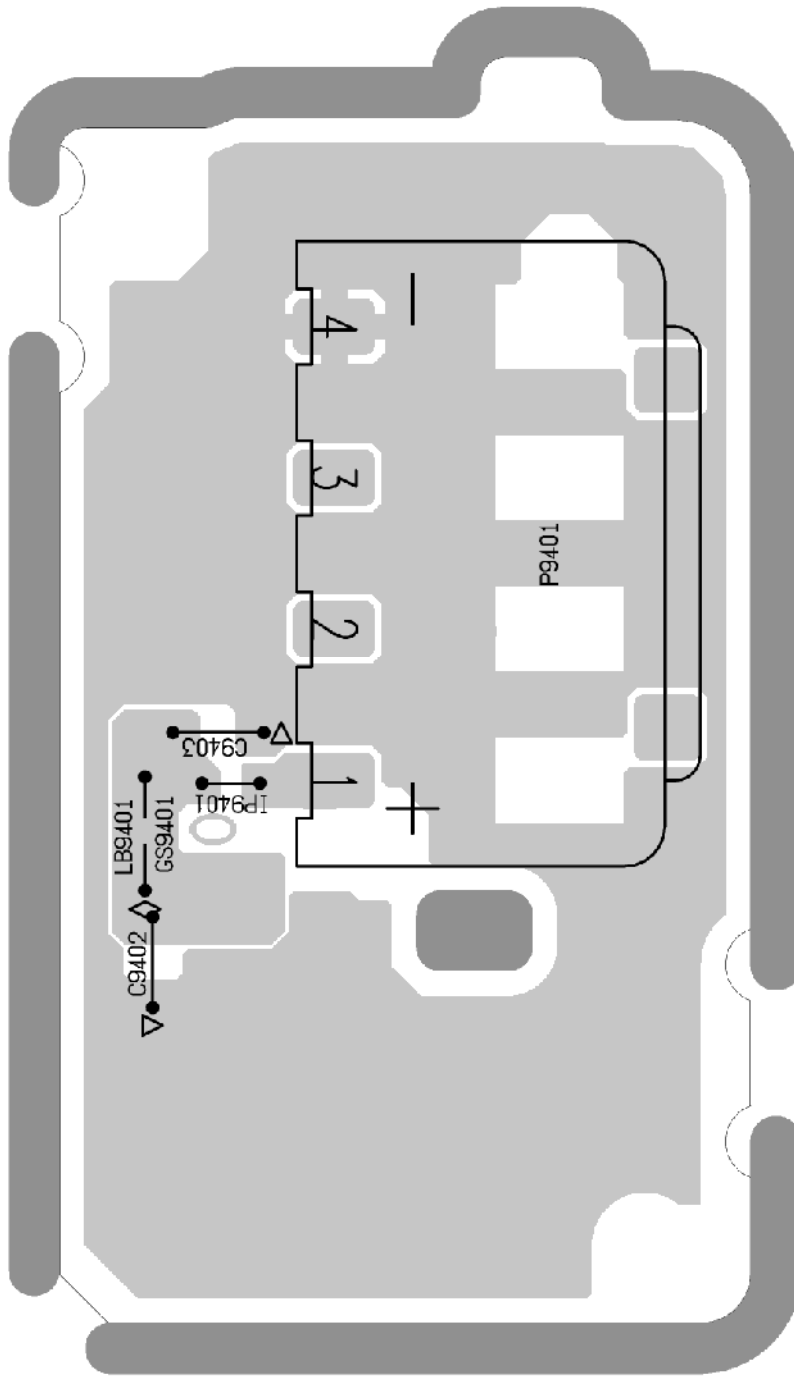

Model No. : DMC-TZ80/TZ81/ZS60 Battery P.C.B. (Foil Side)

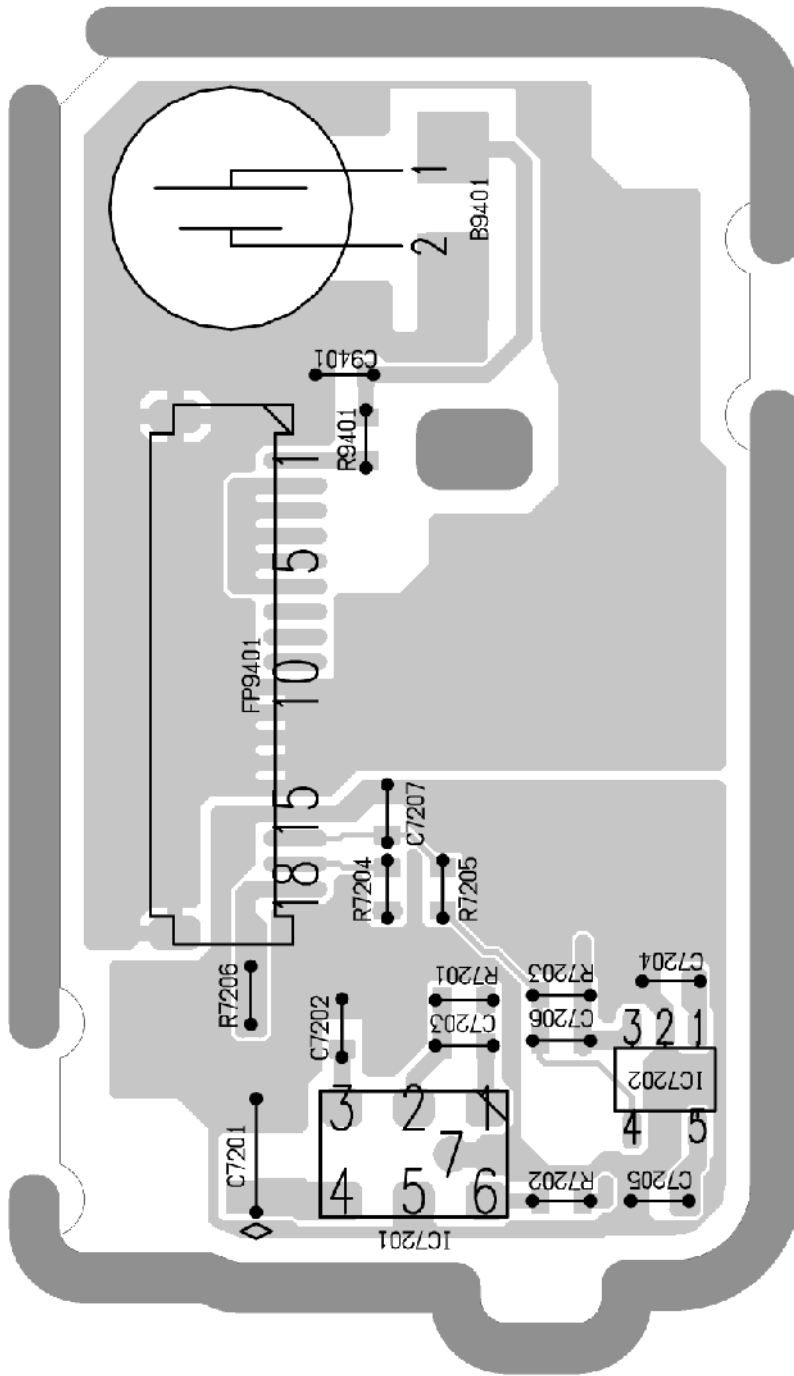

Model No. : DMC-TZ80/TZ81/ZS60 Lens Flex P.C.B.

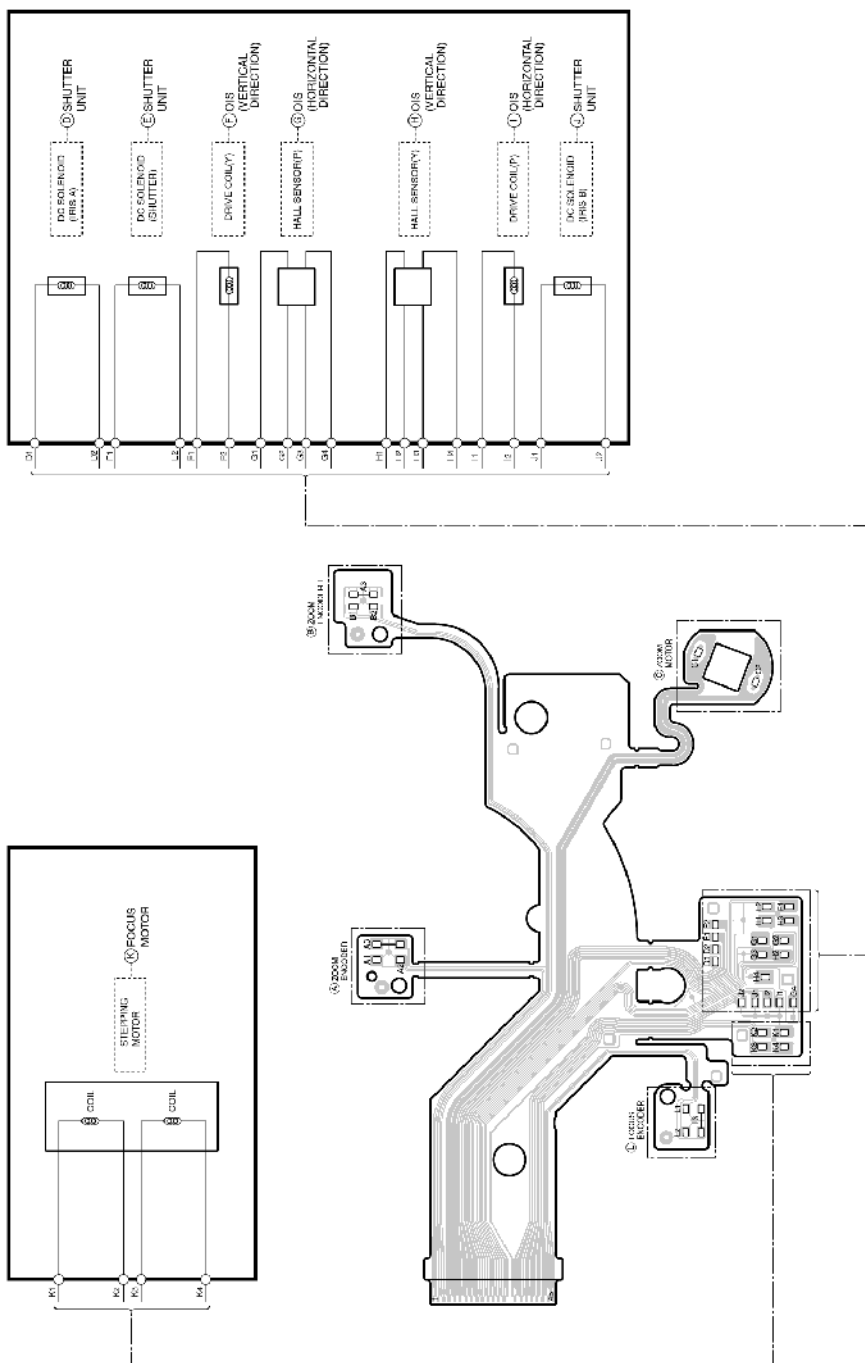

Model No. : DMC-TZ80/TZ81/ZS60 Parts List

Change	Safety	Ref. No.	Part No.	Part Name & Description	Q'ty	Remarks
		C1010	F1J1A106A043	C.CAPACITOR CH 10V 10U	1	
		C1011	F1G1H330A834	C.CAPACITOR CH 50V 33P	1	
		C1020	F1J1A106A043	C.CAPACITOR CH 10V 10U	1	
		C1021	F1G1H680A834	C.CAPACITOR CH 50V 68P	1	
		C1030	F1J1A106A043	C.CAPACITOR CH 10V 10U	1	
		C1031	F1G1H270A834	C.CAPACITOR CH 50V 27P	1	
		C1040	F1J1A106A043	C.CAPACITOR CH 10V 10U	1	
		C1041	F1G1H4710004	C.CAPACITOR CH 50V 470P	1	
		C1051	F1J1A106A043	C.CAPACITOR CH 10V 10U	1	
		C1052	F1H1A105A025	C.CAPACITOR CH 10V 1U	1	
		C1053	F1G1H392A571	C.CAPACITOR CH 50V 3900P	1	
		C1054	F1G1C104A146	C.CAPACITOR CH 16V 0.1U	1	
		C1055	F1J0J2260004	C.CAPACITOR CH 6.3V 22U	1	
		C1056	F1J1A106A043	C.CAPACITOR CH 10V 10U	1	
		C1061	F1J1A106A043	C.CAPACITOR CH 10V 10U	1	
		C1062	F1H1A105A025	C.CAPACITOR CH 10V 1U	1	
		C1063	F1G1H392A571	C.CAPACITOR CH 50V 3900P	1	
		C1064	F1G1C104A146	C.CAPACITOR CH 16V 0.1U	1	
		C1065	F1J0J2260004	C.CAPACITOR CH 6.3V 22U	1	
		C1066	F1J1A106A043	C.CAPACITOR CH 10V 10U	1	
		C1067	F1H1A105A025	C.CAPACITOR CH 10V 1U	1	
		C1068	F1H1A105A025	C.CAPACITOR CH 10V 1U	1	
		C1080	F1J1V1050001	C.CAPACITOR CH 35V 1U	1	
		C1081	F1G0J1050007	C.CAPACITOR CH 6.3V 1U	1	
		C1082	F1H1C105A167	C.CAPACITOR CH 16V 1U	1	
		C1083	F1G1C104A146	C.CAPACITOR CH 16V 0.1U	1	
		C1110	F1G0J1050007	C.CAPACITOR CH 6.3V 1U	1	
		C1111	F1G0J1050007	C.CAPACITOR CH 6.3V 1U	1	
		C1120	F1G0J1050007	C.CAPACITOR CH 6.3V 1U	1	
		C1121	F1G0J1050007	C.CAPACITOR CH 6.3V 1U	1	
		C1130	F1H1A105A025	C.CAPACITOR CH 10V 1U	1	
		C1131	F1H1A105A025	C.CAPACITOR CH 10V 1U	1	
		C1210	F1H1A105A025	C.CAPACITOR CH 10V 1U	1	
		C1211	F1H1A105A025	C.CAPACITOR CH 10V 1U	1	
		C1220	F1G0J1050007	C.CAPACITOR CH 6.3V 1U	1	EE, GC, GA, GN, P, PP, GH
		C1221	F1G0J1050007	C.CAPACITOR CH 6.3V 1U	1	
		C1222	F1G0J1050007	C.CAPACITOR CH 6.3V 1U	1	(TZ80/81) EG, EF, EB
		C1230	F1G0J1050007	C.CAPACITOR CH 6.3V 1U	1	
		C1231	F1G0J1050007	C.CAPACITOR CH 6.3V 1U	1	
		C1240	F1H1A105A025	C.CAPACITOR CH 10V 1U	1	
		C1241	F1H1A105A025	C.CAPACITOR CH 10V 1U	1	
		C1310	F1H1A105A025	C.CAPACITOR CH 10V 1U	1	
		C1311	F1H1A105A025	C.CAPACITOR CH 10V 1U	1	
		C1410	F1G0J1050007	C.CAPACITOR CH 6.3V 1U	1	
		C1411	F1G0J1050007	C.CAPACITOR CH 6.3V 1U	1	
		C1501	F1J1A106A043	C.CAPACITOR CH 10V 10U	1	
		C1502	F1G1C104A146	C.CAPACITOR CH 16V 0.1U	1	
		C1503	F1G0J1050007	C.CAPACITOR CH 6.3V 1U	1	
		C1504	F1G0J1050007	C.CAPACITOR CH 6.3V 1U	1	
		C1505	F1H1A105A025	C.CAPACITOR CH 10V 1U	1	
		C1506	F1G0J225A034	C.CAPACITOR CH 6.3V 2.2U	1	
		C1508	F1J1A106A043	C.CAPACITOR CH 10V 10U	1	
		C1509	F1H1A105A025	C.CAPACITOR CH 10V 1U	1	
		C1510	F1H1A105A025	C.CAPACITOR CH 10V 1U	1	
		C1511	F1G1A2240008	C.CAPACITOR CH 10V 0.22U	1	
		C1512	F1G1C104A146	C.CAPACITOR CH 16V 0.1U	1	
		C1513	F1G1C1030008	C.CAPACITOR CH 16V 0.01U	1	
		C1515	F1H1A105A025	C.CAPACITOR CH 10V 1U	1	
		C1516	F1H1A105A025	C.CAPACITOR CH 10V 1U	1	
		C1517	F1G0J1050007	C.CAPACITOR CH 6.3V 1U	1	
		C1525	F1H1A105A025	C.CAPACITOR CH 10V 1U	1	

		C1526	F1G1H4710004	C.CAPACITOR CH 50V 470P	1	
--	--	-------	--------------	-------------------------	---	--

Model No. : DMC-TZ80/TZ81/ZS60 Parts List

Change	Safety	Ref. No.	Part No.	Part Name & Description	Q'ty	Remarks
		C1901	F1H1A4750004	C.CAPACITOR CH 10V 4.7U	1	
		C1902	F1H1A4750004	C.CAPACITOR CH 10V 4.7U	1	
		C1903	F1H1A4750004	C.CAPACITOR CH 10V 4.7U	1	
		C1904	F1H1A4750004	C.CAPACITOR CH 10V 4.7U	1	
		C1905	F1H1A105A025	C.CAPACITOR CH 10V 1U	1	
		C1906	F1H1A105A025	C.CAPACITOR CH 10V 1U	1	
		C1907	F1H1A105A025	C.CAPACITOR CH 10V 1U	1	
		C1908	F1G1C1030008	C.CAPACITOR CH 16V 0.01U	1	
		C1909	F1G1C223A081	C.CAPACITOR CH 16V 0.022U	1	
		C1910	F1H1A105A025	C.CAPACITOR CH 10V 1U	1	
		C2001	F1G1A1040006	C.CAPACITOR CH 10V 0.1U	1	
		C2002	F1G0J1050007	C.CAPACITOR CH 6.3V 1U	1	
		C2003	F1G1A1040006	C.CAPACITOR CH 10V 0.1U	1	
		C4003	F1G0J1050007	C.CAPACITOR CH 6.3V 1U	1	
		C4004	F1G0J1050007	C.CAPACITOR CH 6.3V 1U	1	
		C4005	F1G0J1050007	C.CAPACITOR CH 6.3V 1U	1	
		C4006	F1G0J1050007	C.CAPACITOR CH 6.3V 1U	1	
		C4007	F1H1A4750004	C.CAPACITOR CH 10V 4.7U	1	
		C4008	F1H1E105A116	C.CAPACITOR CH 25V 1U	1	
		C4009	F1H1E105A116	C.CAPACITOR CH 25V 1U	1	
		C4010	F1G0J225A034	C.CAPACITOR CH 6.3V 2.2U	1	
		C4012	F1H1A105A025	C.CAPACITOR CH 10V 1U	1	
		C4013	F1H1A4750004	C.CAPACITOR CH 10V 4.7U	1	
		C4014	F1H1E105A116	C.CAPACITOR CH 25V 1U	1	
		C4015	F1H1E105A116	C.CAPACITOR CH 25V 1U	1	
		C4016	F1J1E225A157	C.CAPACITOR CH 6.3V 2.2U	1	
		C4017	F1J1E225A157	C.CAPACITOR CH 6.3V 2.2U	1	
		C4018	F1G0J225A034	C.CAPACITOR CH 6.3V 2.2U	1	
		C4019	F1H1A4750004	C.CAPACITOR CH 10V 4.7U	1	
		C5001	F1G1C223A081	C.CAPACITOR CH 16V 0.022U	1	
		C5002	F1G1C223A081	C.CAPACITOR CH 16V 0.022U	1	
		C5005	F1G0J1050007	C.CAPACITOR CH 6.3V 1U	1	
		C5006	F1G0J1050007	C.CAPACITOR CH 6.3V 1U	1	
		C5007	F1G0J1050007	C.CAPACITOR CH 6.3V 1U	1	
		C5009	F1H0J4750005	C.CAPACITOR CH 6.3V 4.7U	1	
		C5010	F1G1A1040006	C.CAPACITOR CH 10V 0.1U	1	
		C5012	F1G0J1050007	C.CAPACITOR CH 6.3V 1U	1	
		C5013	F1G0J1050007	C.CAPACITOR CH 6.3V 1U	1	
		C5015	F1G1A1040006	C.CAPACITOR CH 10V 0.1U	1	
		C5016	F1G1A1040006	C.CAPACITOR CH 10V 0.1U	1	
		C5020	F1G1H4700003	C.CAPACITOR CH 50V 47P	1	
		C5021	F1G1H4700003	C.CAPACITOR CH 50V 47P	1	
		C6001	F1G1H9R0A723	C.CAPACITOR CH 50V 9P	1	
		C6004	F1G1A1040006	C.CAPACITOR CH 10V 0.1U	1	
		C6005	F1G1C1030008	C.CAPACITOR CH 16V 0.01U	1	
		C6006	F1G1C1030008	C.CAPACITOR CH 16V 0.01U	1	
		C6007	F1G1A1040006	C.CAPACITOR CH 10V 0.1U	1	
		C6008	F1G1A1040006	C.CAPACITOR CH 10V 0.1U	1	
		C6009	F1G1A1040006	C.CAPACITOR CH 10V 0.1U	1	
		C6010	F1G1A1040006	C.CAPACITOR CH 10V 0.1U	1	
		C6011	F1G1A1040006	C.CAPACITOR CH 10V 0.1U	1	
		C6012	F1G1A1040006	C.CAPACITOR CH 10V 0.1U	1	
		C6013	F1G1A1040006	C.CAPACITOR CH 10V 0.1U	1	
		C6014	F1G1A1040006	C.CAPACITOR CH 10V 0.1U	1	
		C6019	F1G1E102A086	C.CAPACITOR CH 25V 1000P	1	
		C6020	F1G1E102A086	C.CAPACITOR CH 25V 1000P	1	
		C6021	F1G1E102A086	C.CAPACITOR CH 25V 1000P	1	
		C6022	F1G1E102A086	C.CAPACITOR CH 25V 1000P	1	
		C6023	F1J1A106A043	C.CAPACITOR CH 10V 10U	1	
		C6024	F1G1A1040006	C.CAPACITOR CH 10V 0.1U	1	
		C6025	F1G1C1030008	C.CAPACITOR CH 16V 0.01U	1	

		C6026	F1G1C1030008	C.CAPACITOR CH 16V 0.01U	1	
--	--	-------	--------------	--------------------------	---	--

Model No. : DMC-TZ80/TZ81/ZS60 Parts List

Change	Safety	Ref. No.	Part No.	Part Name & Description	Q'ty	Remarks
		C6027	F1G1C1030008	C.CAPACITOR CH 16V 0.01U	1	
		C6028	F1G1C1030008	C.CAPACITOR CH 16V 0.01U	1	
		C6030	F1J1A106A043	C.CAPACITOR CH 10V 10U	1	
		C6031	F1G1A1040006	C.CAPACITOR CH 10V 0.1U	1	
		C6032	F1G1C1030008	C.CAPACITOR CH 16V 0.01U	1	
		C6033	F1J1A106A043	C.CAPACITOR CH 10V 10U	1	
		C6034	F1G1A1040006	C.CAPACITOR CH 10V 0.1U	1	
		C6035	F1G1C1030008	C.CAPACITOR CH 16V 0.01U	1	
		C6036	F1J1A106A043	C.CAPACITOR CH 10V 10U	1	
		C6037	F1G1A1040006	C.CAPACITOR CH 10V 0.1U	1	
		C6038	F1G1C1030008	C.CAPACITOR CH 16V 0.01U	1	
		C6039	F1G1C1030008	C.CAPACITOR CH 16V 0.01U	1	
		C6040	F1G1A1040006	C.CAPACITOR CH 10V 0.1U	1	
		C6041	F1G1C1030008	C.CAPACITOR CH 16V 0.01U	1	
		C6042	F1G1C1030008	C.CAPACITOR CH 16V 0.01U	1	
		C6044	F1G1A1040006	C.CAPACITOR CH 10V 0.1U	1	
		C6045	F1G1C1030008	C.CAPACITOR CH 16V 0.01U	1	
		C6046	F1J1A106A043	C.CAPACITOR CH 10V 10U	1	
		C6047	F1G1A1040006	C.CAPACITOR CH 10V 0.1U	1	
		C6048	F1G1C1030008	C.CAPACITOR CH 16V 0.01U	1	
		C6049	F1G1A1040006	C.CAPACITOR CH 10V 0.1U	1	
		C6050	F1G1C1030008	C.CAPACITOR CH 16V 0.01U	1	
		C6051	F1G1A1040006	C.CAPACITOR CH 10V 0.1U	1	
		C6052	F1G1C1030008	C.CAPACITOR CH 16V 0.01U	1	
		C6053	F1G1C1030008	C.CAPACITOR CH 16V 0.01U	1	
		C6054	F1G1C1030008	C.CAPACITOR CH 16V 0.01U	1	
		C6055	F1G1A1040006	C.CAPACITOR CH 10V 0.1U	1	
		C6056	F1G1C1030008	C.CAPACITOR CH 16V 0.01U	1	
		C6057	F1G1H100A723	C.CAPACITOR CH 50V 10P	1	
		C6058	F1G1E102A086	C.CAPACITOR CH 25V 1000P	1	
		C6061	F1G1C1030008	C.CAPACITOR CH 16V 0.01U	1	
		C6062	F1G1C1030008	C.CAPACITOR CH 16V 0.01U	1	
		C6063	F1G1C1030008	C.CAPACITOR CH 16V 0.01U	1	
		C6064	F1G1C1030008	C.CAPACITOR CH 16V 0.01U	1	
		C6065	F1G1C1030008	C.CAPACITOR CH 16V 0.01U	1	
		C6066	F1G1C1030008	C.CAPACITOR CH 16V 0.01U	1	
		C6067	F1G1C1030008	C.CAPACITOR CH 16V 0.01U	1	
		C6068	F1G1C1030008	C.CAPACITOR CH 16V 0.01U	1	
		C6069	F1G1C1030008	C.CAPACITOR CH 16V 0.01U	1	
		C6070	F1G1C1030008	C.CAPACITOR CH 16V 0.01U	1	
		C6071	F1J1A106A043	C.CAPACITOR CH 10V 10U	1	
		C6201	F1H0J4750004	C.CAPACITOR CH 6.3V 4.7U	1	
		C6202	F1G1A1040006	C.CAPACITOR CH 10V 0.1U	1	
		C6203	F1G1A1040006	C.CAPACITOR CH 10V 0.1U	1	
		C6502	F1G1H5R0A831	C.CAPACITOR CH 50V 5P	1	
		C6503	F1G1H5R0A831	C.CAPACITOR CH 50V 5P	1	
		C6504	F1G1H5R0A831	C.CAPACITOR CH 50V 5P	1	
		C6505	F1G1H5R0A831	C.CAPACITOR CH 50V 5P	1	
		C6506	F1G1H5R0A831	C.CAPACITOR CH 50V 5P	1	
		C6507	F1H0J1060006	C.CAPACITOR CH 6.3V 10U	1	
		C6509	F1H0J4750004	C.CAPACITOR CH 6.3V 4.7U	1	
		C6510	F1G1C1030008	C.CAPACITOR CH 16V 0.01U	1	
		C6512	F1H1A105A025	C.CAPACITOR CH 10V 1U	1	
		C6513	F1H1A105A025	C.CAPACITOR CH 10V 1U	1	
		C6514	F1H1A105A025	C.CAPACITOR CH 10V 1U	1	
		C7001	F1H1A105A025	C.CAPACITOR CH 10V 1U	1	
		C7003	F1H1A105A025	C.CAPACITOR CH 10V 1U	1	
		C7006	F1G1C1030008	C.CAPACITOR CH 16V 0.01U	1	
		C7007	F1G1C1030008	C.CAPACITOR CH 16V 0.01U	1	
		C7008	F1G1C1030008	C.CAPACITOR CH 16V 0.01U	1	
		C7009	F1G1C1030008	C.CAPACITOR CH 16V 0.01U	1	



		C7010	F1G0J1050007	C.CAPACITOR CH 6.3V 1U	1	
--	--	-------	--------------	------------------------	---	--

Model No. : DMC-TZ80/TZ81/ZS60 Parts List

Change	Safety	Ref. No.	Part No.	Part Name & Description	Q'ty	Remarks
		C7011	F1G0J1050007	C.CAPACITOR CH 6.3V 1U	1	
		C7014	F1H1A105A025	C.CAPACITOR CH 10V 1U	1	
		C7019	F1J1A106A043	C.CAPACITOR CH 10V 10U	1	
		C7101	F1H0J4750004	C.CAPACITOR CH 6.3V 4.7U	1	
		C7102	F1G1A1040006	C.CAPACITOR CH 10V 0.1U	1	
		C7103	F1G1A1040006	C.CAPACITOR CH 10V 0.1U	1	
		C7104	F1G1A1040006	C.CAPACITOR CH 10V 0.1U	1	
		C7105	F1G1A1040006	C.CAPACITOR CH 10V 0.1U	1	
		C7201	F1J1A106A043	C.CAPACITOR CH 10V 10U	1	
		C7202	F1G1A1040006	C.CAPACITOR CH 10V 0.1U	1	
		C7203	F1G1E222A086	C.CAPACITOR CH 25V 2200P	1	
		C7204	F1G1C1030008	C.CAPACITOR CH 16V 0.01U	1	
		C7205	F1G0J1050007	C.CAPACITOR CH 6.3V 1U	1	
		C7206	F1G1C1030008	C.CAPACITOR CH 16V 0.01U	1	
		C9006	F1G1A1040006	C.CAPACITOR CH 10V 0.1U	1	
		C9007	F1G1A1040006	C.CAPACITOR CH 10V 0.1U	1	
		C9010	F1H0J4750004	C.CAPACITOR CH 6.3V 4.7U	1	
		C9027	F1H0J4750004	C.CAPACITOR CH 6.3V 4.7U	1	
		C9028	F1H0J1060006	C.CAPACITOR CH 6.3V 10U	1	
		C9029	F1G0J1050007	C.CAPACITOR CH 6.3V 1U	1	
		C9030	F1J1A106A043	C.CAPACITOR CH 10V 10U	1	
		C9031	F1G1A1040006	C.CAPACITOR CH 10V 0.1U	1	
		C9032	F1J1A106A043	C.CAPACITOR CH 10V 10U	1	
		C9033	F1H0J4750005	C.CAPACITOR CH 6.3V 4.7U	1	
		C9071	F1G0J1050007	C.CAPACITOR CH 6.3V 1U	1	
		C9081	F1G1A1040006	C.CAPACITOR CH 10V 0.1U	1	
		C9082	F1G1H101A834	C.CAPACITOR CH 50V 100P	1	
		C9083	F1G1H101A834	C.CAPACITOR CH 50V 100P	1	
		C9084	F1G0J1050007	C.CAPACITOR CH 6.3V 1U	1	
		C9085	F1H1A4750004	C.CAPACITOR CH 10V 4.7U	1	
		C9086	F1G0J1050007	C.CAPACITOR CH 6.3V 1U	1	
		C9101	F1G1E102A086	C.CAPACITOR CH 25V 1000P	1	
		C9102	F1G0J1050007	C.CAPACITOR CH 6.3V 1U	1	
		C9103	F1G1H8R0A723	C.CAPACITOR CH 50V 8P	1	
		C9104	F1G1H8R0A723	C.CAPACITOR CH 50V 8P	1	
		C9105	F1G0J1050007	C.CAPACITOR CH 6.3V 1U	1	
		C9106	F1J1A106A043	C.CAPACITOR CH 10V 10U	1	
		C9111	F1J1A106A043	C.CAPACITOR CH 10V 10U	1	
		C9402	F1H1C105A167	C.CAPACITOR CH 16V 1U	1	
		D1040	B0ACRC000001	DIODE	1	E.S.D.
		D1501	B0JCDD000019	DIODE	1	E.S.D.
		D1502	B0JCDD000019	DIODE	1	E.S.D.
		D1503	B0JCDD000019	DIODE	1	E.S.D.
		D9102	B0ADDH000014	DIODE	1	E.S.D.
		D9104	B0ADDH000014	DIODE	1	E.S.D.
		FL2001	EXC28CH900U	FILTER	1	
		FL2002	EXC28CH900U	FILTER	1	
		FP9001	K1MY51BA0667	CONNECTOR 51P	1	
		FP9002	K1MY25BA0556	CONNECTOR 25P	1	
		FP9003	K1MY61BA0667	CONNECTOR 61P	1	
		FP9004	K1MY45BA0667	CONNECTOR 45P	1	
		FP9006	K1MY13BA0585	CONNECTOR 13P	1	
		FP9008	K1MY33BA0556	CONNECTOR 33P	1	
		FP9009	K1MY15BA0585	CONNECTOR 15P	1	
		FP9010	K1MY08BA0557	CONNECTOR 8P	1	
		FP9011	K1MY05BA0557	CONNECTOR 5P	1	
		FP9050	K1MY06BA0557	CONNECTOR 6P	1	
		FP9051	K1MY18BA0633	CONNECTOR 18P	1	
		FP9401	K1MY18BA0633	CONNECTOR 18P	1	
		IC1001	C1ZBZ0005550	IC	1	E.S.D.
		IC1050	C0DBAYY02385	IC	1	E.S.D.

		IC1060	C0DBAYY02385	IC	1	E.S.D.
--	--	--------	--------------	----	---	--------

Model No. : DMC-TZ80/TZ81/ZS60 Parts List

Change	Safety	Ref. No.	Part No.	Part Name & Description	Q'ty	Remarks
		IC1061	C0DBGYY05343	IC	1	E.S.D.
		IC1080	C0DBAYY02207	IC	1	E.S.D.
		IC1110	C0DBGYY03640	IC	1	E.S.D.
		IC1120	C0DBGYY03614	IC	1	E.S.D.
		IC1130	C0DBGYY03678	IC	1	E.S.D.
		IC1210	C0DBGYY05359	IC	1	E.S.D.
		IC1220	C0DBGYY03614	IC	1	E.S.D.
		IC1230	C0DBGYY03614	IC	1	E.S.D.
		IC1240	C0DBGYY05349	IC	1	E.S.D.
		IC1310	C0DBGYY02527	IC	1	E.S.D.
		IC1410	C0DBGYY03640	IC	1	E.S.D.
		IC1501	C1ZBZ0005562	IC	1	E.S.D.
		IC1502	SUBF000022	IC	1	E.S.D. [INBD]
		IC1503	C1CB00004471	IC	1	E.S.D.
		IC1510	C0DBGYY02368	IC	1	E.S.D.
		IC1511	C0DBGYY06165	IC	1	E.S.D.
		IC6001	SCG0002	IC	1	E.S.D.
		IC6003	RS10825	IC	1	E.S.D.
		IC6201	L2EE00000038	IC	1	E.S.D.
		IC6501	C0DBGYY00779	IC	1	E.S.D.
		IC7101	EWTS9PDL1A	IC	1	E.S.D. [INBD]
		IC7201	EWTS9RCL1A	IC	1	E.S.D. [INBD]
		IC7202	C0ABGA000035	IC	1	E.S.D.
		IC9001	C0JBAU000226	IC	1	E.S.D.
		IC9101	C1AB00003449	IC	1	E.S.D.
		IP1001	ERBRD0R75X	FUSE 32V 750mA	1	
		IP2001	ERBRD2R00X	FUSE 32V 2.0A	1	
		IP9401	ERBRD2R50X	FUSE 32V 2.5A	1	
		JK2001	K1FY105E0014	JACK	1	
		JK2002	K1FY119E0057	JACK	1	
		L1010	G1C150MA0477	CHIP INDUCTOR 15UH	1	
		L1020	G1C150MA0477	CHIP INDUCTOR 15UH	1	
		L1030	G1C150MA0477	CHIP INDUCTOR 15UH	1	
		L1040	G1C4R7MA0584	CHIP INDUCTOR 4.7UH	1	
		L1050	G1C1R5MA0577	CHIP INDUCTOR 1.5UH	1	
		L1060	G1C2R2MA0477	CHIP INDUCTOR 2.2UH	1	
		L1080	G1C100MA0392	CHIP INDUCTOR 10UH	1	
		L1500	G1C2R2MA0392	CHIP INDUCTOR 2.2UH	1	
		L2001	EXC24CE900U	FILTER	1	
		LB2001	J0JCC0000415	FILTER	1	
		LB6002	J0JFC0000006	FILTER	1	
		LB9001	J0JFC00000006	FILTER	1	
		LB9002	J0JFC00000006	FILTER	1	
		LB9010	J0JCC0000415	FILTER	1	
		LB9011	J0JCC0000415	FILTER	1	
		P6501	K1NA09E00166	SD CARD CONNECTOR	1	
		P9401	K4ZZ04000064	CONNECTOR 4P	1	
		Q1080	MTM861280LBF	TRANSISTOR	1	E.S.D.
		Q1502	B1CHPB000008	TRANSISTOR	1	E.S.D.
		Q1505	B1CFG0000022	TRANSISTOR	1	E.S.D.
		Q1506	B1CFG0000022	TRANSISTOR	1	E.S.D.
		Q1507	B1CFG0000022	TRANSISTOR	1	E.S.D.
		Q1508	B1ABCF000301	TRANSISTOR	1	E.S.D.
		Q2001	B1CFGD000003	TRANSISTOR	1	E.S.D.
		Q2002	B1CFJD000007	TRANSISTOR	1	E.S.D.
		Q6501	MTM861270LBF	TRANSISTOR	1	E.S.D.
		Q9081	B1HFCFA00035	TRANSISTOR	1	E.S.D.
		Q9101	B1ABCF000302	TRANSISTOR	1	E.S.D.
		QR1080	B1GBCFY0217	TRANSISTOR-RESISTOR	1	E.S.D.
		QR1081	B1GFCFL0009	TRANSISTOR-RESISTOR	1	E.S.D.

		QR1503	B1GBCFY0224	TRANSISTOR-RESISTOR	1	E.S.D.
		QR1504	B1GBCFY0224	TRANSISTOR-RESISTOR	1	E.S.D.

Model No. : DMC-TZ80/TZ81/ZS60 Parts List

Change	Safety	Ref. No.	Part No.	Part Name & Description	Q'ty	Remarks
		QR1505	B1GBCFY0224	TRANSISTOR-RESISTOR	1	E.S.D.
		QR2003	B1GKCFY0029	TRANSISTOR-RESISTOR	1	E.S.D.
		QR6501	B1GBCFY0217	TRANSISTOR-RESISTOR	1	E.S.D.
		QR6502	B1GDIFY0150	TRANSISTOR-RESISTOR	1	E.S.D.
		QR9102	B1GDIFY0150	TRANSISTOR-RESISTOR	1	E.S.D.
		R1011	D1BA5602A022	M.RESISTOR CH 1/16W 56K	1	
		R1012	D1BA1602A022	M.RESISTOR CH 1/16W 16K	1	
		R1022	D1BA6802A022	M.RESISTOR CH 1/16W 68K	1	
		R1023	D1BA2402A022	M.RESISTOR CH 1/16W 24K	1	
		R1031	D1BA1103A022	M.RESISTOR CH 1/16W 110K	1	
		R1032	D1BA2002A022	M.RESISTOR CH 1/16W 20K	1	
		R1041	D1BA1502A022	M.RESISTOR CH 1/16W 15K	1	
		R1042	D1BA6802A022	M.RESISTOR CH 1/16W 68K	1	
		R1044	D1BA3302A022	M.RESISTOR CH 1/16W 33K	1	
		R1053	D1BA1002A022	M.RESISTOR CH 1/16W 10K	1	
		R1054	D1BA3002A022	M.RESISTOR CH 1/16W 30K	1	
		R1063	D1BA2202A022	M.RESISTOR CH 1/16W 22K	1	
		R1064	D1BA2002A022	M.RESISTOR CH 1/16W 20K	1	
		R1081	D1BA6R80A023	M.RESISTOR CH 1/16W 6.8	1	
		R1082	DOGA473JA023	M.RESISTOR CH 1/10W 47K	1	
		R1083	DOGA103JA023	M.RESISTOR CH 1/10W 10K	1	
		R1085	DOGA152JA023	M.RESISTOR CH 1/10W 1.5K	1	
		R1086	DOGA223JA023	M.RESISTOR CH 1/10W 22K	1	
		R1501	D1BA1002A022	M.RESISTOR CH 1/16W 10K	1	
		R1504	DOGA102JA023	M.RESISTOR CH 1/10W 1K	1	
		R1507	DOGA470JA023	M.RESISTOR CH 1/10W 47	1	
		R1508	DOGA332JA023	M.RESISTOR CH 1/10W 3.3K	1	
		R1509	DOGA332JA023	M.RESISTOR CH 1/10W 3.3K	1	
		R1511	ERJ2RKD684X	M.RESISTOR CH 1/16W 680K	1	
		R1512	D1BA3003A022	M.RESISTOR CH 1/16W 300K	1	
		R1513	DOGA104JA023	M.RESISTOR CH 1/16W 100K	1	
		R1520	DOGA364JA023	M.RESISTOR CH 1/16W 360K	1	
		R1521	DOGA564JA023	M.RESISTOR CH 1/16W 560K	1	
		R1522	D1BA3001A022	M.RESISTOR CH 1/16W 3K	1	
		R1531	D1BA8201A022	M.RESISTOR CH 1/16W 8.2K	1	
		R1560	DOGA104JA023	M.RESISTOR CH 1/16W 100K	1	
		R1561	DOGA104JA023	M.RESISTOR CH 1/16W 100K	1	
		R1573	DOGA104JA023	M.RESISTOR CH 1/16W 100K	1	
		R1579	DOGA102JA023	M.RESISTOR CH 1/10W 1K	1	
		R1591	DOGA334JA023	M.RESISTOR CH 1/10W 330K	1	
		R1592	DOGA104JA023	M.RESISTOR CH 1/16W 100K	1	
		R1593	DOGA102JA023	M.RESISTOR CH 1/10W 1K	1	
		R1902	DOGA104JA023	M.RESISTOR CH 1/16W 100K	1	
		R1903	D1BA8202A022	M.RESISTOR CH 1/16W 82K	1	
		R2007	DOGA473JA023	M.RESISTOR CH 1/10W 47K	1	
		R2008	DOGA273JA023	M.RESISTOR CH 1/10W 27K	1	
		R2010	DOGA330JA023	M.RESISTOR CH 1/10W 33	1	
		R2011	DOGA330JA023	M.RESISTOR CH 1/10W 33	1	
		R2014	DOGA202JA023	M.RESISTOR CH 1/10W 2K	1	
		R2015	DOGA202JA023	M.RESISTOR CH 1/10W 2K	1	
		R5002	DOGA333JA023	M.RESISTOR CH 1/10W 33K	1	
		R5003	DOGA333JA023	M.RESISTOR CH 1/10W 33K	1	
		R5006	DOGA222JA023	M.RESISTOR CH 1/10W 2.2K	1	
		R5008	DOGA222JA023	M.RESISTOR CH 1/10W 2.2K	1	
		R6004	DOGA103JA023	M.RESISTOR CH 1/10W 10K	1	
		R6005	D1BA5100A022	M.RESISTOR CH 1/16W 510	1	
		R6006	D1BA5100A022	M.RESISTOR CH 1/16W 510	1	
		R6007	D1BA5100A022	M.RESISTOR CH 1/16W 510	1	
		R6008	D1BA5100A022	M.RESISTOR CH 1/16W 510	1	
		R6009	D1BA5100A022	M.RESISTOR CH 1/16W 510	1	
		R6010	D1BA5100A022	M.RESISTOR CH 1/16W 510	1	

	R6011	D1BA5100A022	M.RESISTOR CH 1/16W 510	1	
--	-------	--------------	-------------------------	---	--

Model No. : DMC-TZ80/TZ81/ZS60 Parts List

Change	Safety	Ref. No.	Part No.	Part Name & Description	Q'ty	Remarks
		R6012	D1BA5100A022	M.RESISTOR CH 1/16W 510	1	
		R6013	D1BA5100A022	M.RESISTOR CH 1/16W 510	1	
		R6014	D1BA5100A022	M.RESISTOR CH 1/16W 510	1	
		R6015	D1BA5100A022	M.RESISTOR CH 1/16W 510	1	
		R6016	D1BA5100A022	M.RESISTOR CH 1/16W 510	1	
		R6017	D1BA2400A022	M.RESISTOR CH 1/16W 240	1	
		R6018	D1BA2400A022	M.RESISTOR CH 1/16W 240	1	
		R6019	D1BA2400A022	M.RESISTOR CH 1/16W 240	1	
		R6020	D1BA2400A022	M.RESISTOR CH 1/16W 240	1	
		R6026	D1BA6801A022	M.RESISTOR CH 1/16W 6.8K	1	
		R6027	D1BA4701A022	M.RESISTOR CH 1/16W 4.7K	1	
		R6028	D1BA2000A022	M.RESISTOR CH 1/16W 200	1	
		R6032	DOGA470JA023	M.RESISTOR CH 1/10W 47	1	
		R6035	DOGA473JA023	M.RESISTOR CH 1/10W 47K	1	
		R6039	DOGA102JA023	M.RESISTOR CH 1/10W 1K	1	
		R6041	DOGA270JA023	M.RESISTOR CH 1/10W 27	1	
		R6042	DOGA470JA023	M.RESISTOR CH 1/10W 47	1	
		R6046	DOGA105JA023	M.RESISTOR CH 1/10W 1M	1	
		R6047	DOGA102JA023	M.RESISTOR CH 1/10W 1K	1	
		R6061	DOGA302JA023	M.RESISTOR CH 1/10W 3K	1	
		R6062	DOGA302JA023	M.RESISTOR CH 1/10W 3K	1	
		R6063	DOGA302JA023	M.RESISTOR CH 1/10W 3K	1	
		R6064	DOGA302JA023	M.RESISTOR CH 1/10W 3K	1	
		R6070	DOGA472JA023	M.RESISTOR CH 1/10W 4.7K	1	
		R6071	D1BA8201A022	M.RESISTOR CH 1/16W 8.2K	1	
		R6072	D1BA1002A022	M.RESISTOR CH 1/16W 10K	1	
		R6076	DOGA102JA023	M.RESISTOR CH 1/10W 1K	1	
		R6077	DOGA622JA023	M.RESISTOR CH 1/10W 5.6K	1	
		R6078	DOGA622JA023	M.RESISTOR CH 1/10W 5.6K	1	
		R6079	DOGA103JA023	M.RESISTOR CH 1/10W 10K	1	
		R6118	DOGAR00J0005	M.RESISTOR CH 1/10W 0	1	
		R6120	DOGAR00J0005	M.RESISTOR CH 1/10W 0	1	
		R6125	DOGAR00J0005	M.RESISTOR CH 1/10W 0	1	(TZ80/81) EG, EP, EF, EB
		R6501	DOGA102JA023	M.RESISTOR CH 1/10W 1K	1	
		R6502	DOGA223JA023	M.RESISTOR CH 1/10W 22K	1	
		R6504	DOGA104JA023	M.RESISTOR CH 1/16W 100K	1	
		R6505	DOGA103JA023	M.RESISTOR CH 1/10W 10K	1	
		R6510	DOGA330JA023	M.RESISTOR CH 1/10W 33	1	
		R7002	D1BA68R0A022	M.RESISTOR CH 1/16W 68	1	
		R7007	D1BA68R0A022	M.RESISTOR CH 1/16W 68	1	
		R7009	D1BA1R00A079	M.RESISTOR CH 1/16W 1	1	
		R7019	DOGAR00J0005	M.RESISTOR CH 1/10W 0	1	
		R7021	D1BA8201A022	M.RESISTOR CH 1/16W 8.2K	1	
		R7201	DOGA223JA023	M.RESISTOR CH 1/10W 22K	1	
		R7202	D1BA1002A022	M.RESISTOR CH 1/16W 10K	1	
		R7203	D1BA6802A022	M.RESISTOR CH 1/16W 68K	1	
		R7204	D1BA6802A022	M.RESISTOR CH 1/16W 68K	1	
		R9006	DOGA103JA023	M.RESISTOR CH 1/10W 10K	1	
		R9008	DOGA103JA023	M.RESISTOR CH 1/10W 10K	1	
		R9009	DOGA392JA023	M.RESISTOR CH 1/10W 3.9K	1	
		R9010	DOGA392JA023	M.RESISTOR CH 1/10W 3.9K	1	
		R9014	DOGA681JA023	M.RESISTOR CH 1/10W 680	1	
		R9031	DOGA102JA023	M.RESISTOR CH 1/10W 1K	1	
		R9053	DOGA101JA023	M.RESISTOR CH 1/10W 100	1	
		R9069	DOGA183JA023	M.RESISTOR CH 1/10W 18K	1	
		R9070	DOGA183JA023	M.RESISTOR CH 1/10W 18K	1	
		R9071	DOGA151JA023	M.RESISTOR CH 1/10W 150	1	
		R9072	DOGA151JA023	M.RESISTOR CH 1/10W 150	1	
		R9073	DOGA331JA023	M.RESISTOR CH 1/10W 330	1	
		R9074	DOGA331JA023	M.RESISTOR CH 1/10W 330	1	
		R9075	DOGA103JA023	M.RESISTOR CH 1/10W 10K	1	

	R9076	DOGA103JA023	M.RESISTOR CH 1/10W 10K	1	
--	-------	--------------	-------------------------	---	--

Model No. : DMC-TZ80/TZ81/ZS60 Parts List

Change	Safety	Ref. No.	Part No.	Part Name & Description	Q'ty	Remarks
		R9077	D0GA223JA023	M.RESISTOR CH 1/10W 22K	1	
		R9078	D0GA223JA023	M.RESISTOR CH 1/10W 22K	1	
		R9079	D0GA752JA023	M.RESISTOR CH 1/10W 7.5K	1	
		R9080	D0GA752JA023	M.RESISTOR CH 1/10W 7.5K	1	
		R9081	D1BA2201A022	M.RESISTOR CH 1/16W 2.2K	1	
		R9082	D1BA75R0A022	M.RESISTOR CH 1/16W 75	1	
		R9083	D1BA2202A022	M.RESISTOR CH 1/16W 22K	1	
		R9084	D0GA302JA023	M.RESISTOR CH 1/10W 3K	1	
		R9085	D0GA680JA023	M.RESISTOR CH 1/10W 68	1	
		R9086	D0GA473JA023	M.RESISTOR CH 1/10W 47K	1	
		R9087	D0GA473JA023	M.RESISTOR CH 1/10W 47K	1	
		R9090	D0GA101JA023	M.RESISTOR CH 1/10W 100	1	
		R9091	D0GA101JA023	M.RESISTOR CH 1/10W 100	1	
		R9092	D0GA101JA023	M.RESISTOR CH 1/10W 100	1	
		R9093	D0GA101JA023	M.RESISTOR CH 1/10W 100	1	
		R9106	ERJ2RKD105X	M.RESISTOR CH 1/16W 1M	1	
		R9107	D1BA2203A022	M.RESISTOR CH 1/16W 220K	1	
		R9109	D0GA331JA023	M.RESISTOR CH 1/10W 330	1	
		R9114	D1BA3902A022	M.RESISTOR CH 1/16W 39K	1	
		R9115	D1BA1203A022	M.RESISTOR CH 1/16W 120K	1	
		R9119	D1BA3302A022	M.RESISTOR CH 1/16W 33K	1	
		R9120	D1BA7502A022	M.RESISTOR CH 1/16W 75K	1	
		R9133	D0GA473JA023	M.RESISTOR CH 1/10W 47K	1	
		R9401	D0GA512JA023	M.RESISTOR CH 1/10W 5.1K	1	
		RX2003	EXB24V472JX	RESISTOR NETWORKS	1	
		RX6003	D1H84734A042	RESISTOR NETWORKS	1	
		RX6005	D1H81014A042	RESISTOR NETWORKS	1	
		RX6006	D1H81014A042	RESISTOR NETWORKS	1	
		RX6007	D1H81014A042	RESISTOR NETWORKS	1	
		RX6008	D1H81014A042	RESISTOR NETWORKS	1	
		RX6012	D1H81034A042	RESISTOR NETWORKS	1	
		RX6501	D1H84734A042	RESISTOR NETWORKS	1	
		RX6502	D1H83304A042	RESISTOR NETWORKS	1	
		RX9101	D1H81024A042	RESISTOR NETWORKS	1	
		TH6001	D4CC11030013	THERMISTOR	1	
		VA9001	D4ED18R00004	VARISTOR	1	
		VA9002	D4ED18R00004	VARISTOR	1	
		VA9004	D4ED18R00004	VARISTOR	1	
		VA9005	D4ED18R00004	VARISTOR	1	
		VA9006	D4ED18R00004	VARISTOR	1	
		VA9007	D4ED18R00004	VARISTOR	1	
		VA9008	D4ED18R00004	VARISTOR	1	
		VA9009	D4ED18R00004	VARISTOR	1	
		VA9010	D4ED18R00004	VARISTOR	1	
		VA9011	D4ED18R00004	VARISTOR	1	
		VA9012	D4ED18R00004	VARISTOR	1	
		VA9013	D4ED18R00004	VARISTOR	1	
		VA9014	D4ED18R00004	VARISTOR	1	
		VA9015	D4ED18R00004	VARISTOR	1	
		X6001	H0J240500048	CRYSTAL OSCILLATOR	1	
		X9101	H0J327200230	CRYSTAL OSCILLATOR	1	

Model No. : DMC-TZ80/TZ81/ZS60 Frame and Casing Section

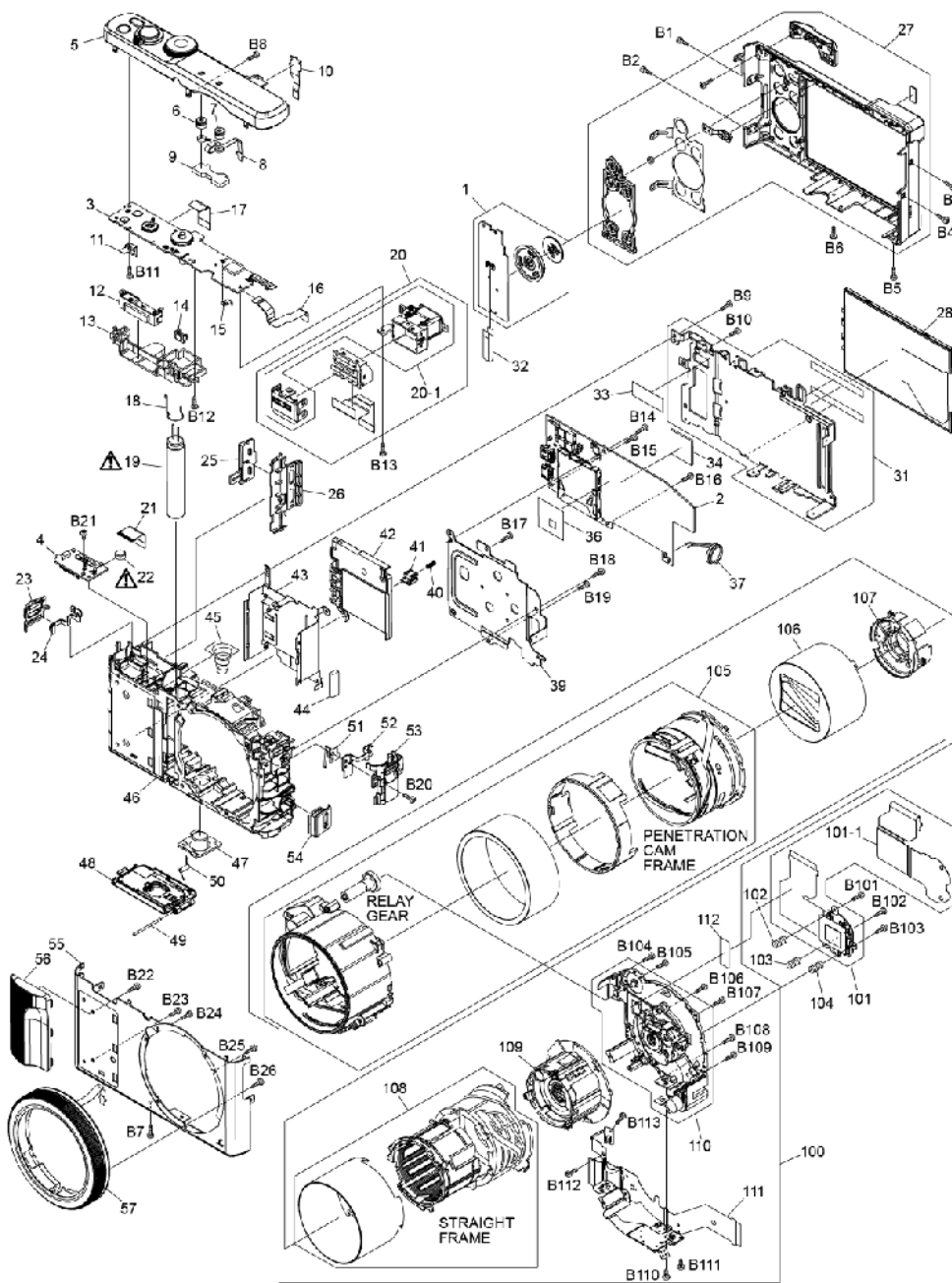

Model No. : DMC-TZ80/TZ81/ZS60 Packing Parts and Accessories Section

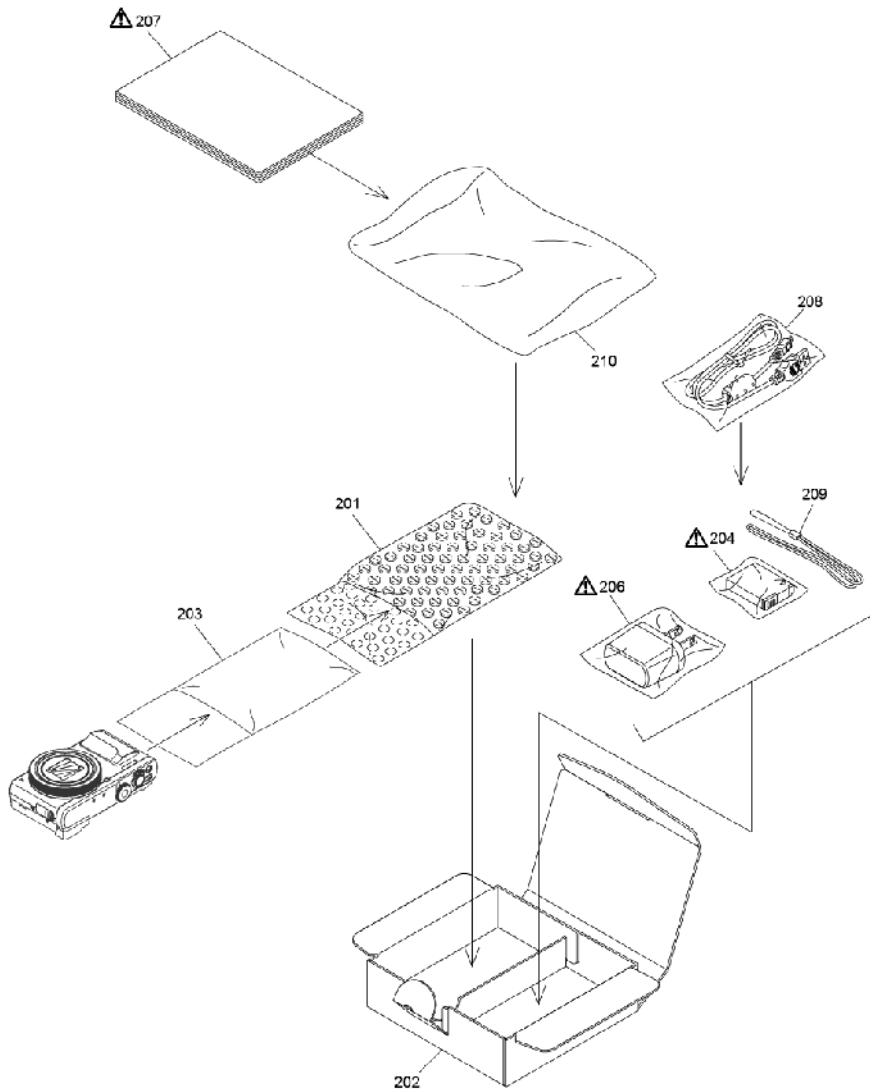

Model No. : DMC-TZ80/TZ81/ZS60 Parts List

Change	Safety	Ref. No.	Part No.	Part Name & Description	Q'ty	Remarks
		1	SYQ0678	REAR OPERATION P.C.B. UNIT	1	
		2	SEP0684AD	MAIN P.C.B.	1	(RTL) E.S.D. (TZ80/81)EG,EP,EF,EB
		2	SEP0684AC	MAIN P.C.B.	1	(RTL) E.S.D. EE,GC,GA,GN,P,PP,GH
		3	SEQ0144	TOP P.C.B. UNIT	1	E.S.D.
		4	SEP0689AA	BATTERY P.C.B.	1	(RTL) E.S.D.
		5	SYK1401	TOP CASE UNIT	1	(-K)
		5	SYK1390	TOP CASE UNIT	1	(-S)
		6	VMT2027	MIC DAMPER	1	
		7	VMT2027	MIC DAMPER	1	
		8	SEP0752AA	MIC UNIT	1	
		9	SGQ0368	MIC SPACER	1	
		10	SEP0718AA	EYE SENSOR FPC	1	E.S.D.
		11	VMP0H67	TOP EARTH PLATE A	1	
		12	EFN-AMFH9ZD	FLASH UNIT	1	
		13	SGQ0683	FLASH SPACER	1	
		14	VGL1365	AF PANEL LIGHT	1	
		15	SMP0289	TOP EARTH PLATE B	1	
		16	STJ0176	WIFI FPC	1	
		17	STJ0173	TOP FPC	1	
		18	SMB0189	EARTH SPRING	1	
	⚠	19	F2A2F8200003	E.CAPACITOR	1	(C8003)
		20	SYK1389	LVF UNIT	1	
		20-1	SYQ0551	LVF COVER UNIT	1	
		21	STJ0174	BATTERY FPC	1	
	⚠	22	ML-421S/DN	BUTTON BATTERY	1	(B9401)
		23	SGK0276K	STRAP COVER (L)	1	
		24	SMP0237	STRAP PLATE (L)	1	
		25	SKF0111K	JACK COVER	1	
		26	SYK1386	JACK DOOR BASE UNIT	1	
		27	SYK1271	REAR CASE UNIT	1	
		28	L5BDDYY00177	LCD UNIT	1	
		31	SYQ0809	FRAME PLATE UNIT	1	
		32	STJ0175	REAR OPERATION FPC	1	
		33	SGQ0711	FRAME PLATE SHEET	1	
		34	SJD0034	HEAT RADIATION PAD	1	
		36	SGS0084	CU PROTECT SHEET	1	
		37	LOAA01A00182	SPEAKER	1	
		39	SMP0240	LENS FIX PLATE	1	
		40	VMB4304	BATTERY LOCK SPRING	1	
		41	SGQ0697	BATTERY LOCK KNOB	1	
		42	SGQ0682	PCB SPACER	1	
		43	SMP0236	BATTERY CASE	1	
		44	SJQ0026	GASKET	1	
		45	VMB4851	BATTERY OUT SPRING	1	
		46	SMK0050	FRAME	1	
		47	VGQ1823	TRIPOD	1	
		48	SYK1273	BATTERY DOOR UNIT	1	
		49	VMS8342	BATTERY DOOR SHAFT	1	
		50	VMB4767	BATTERY DOOR SPRING	1	
		51	SMP0290	FRONT EARTH PLATE	1	
		52	SMP0238	STRAP PLATE (R)	1	
		53	SGK0281K	STRAP COVER (R)	1	
		54	SYK1383	SPEAKER FIX PLATE UNIT	1	
		55	SKK0354K	FRONT CASE	1	
		56	SGQ0680	FRONT GRIP	1	
		57	SYQ0608	CONTROL RING UNIT	1	
		B1	VHD2240	SCREW	1	
		B2	VHD2240	SCREW	1	
		B3	VHD2240	SCREW	1	
		B4	VHD2240	SCREW	1	
		B5	VHD2240	SCREW	1	



























		B6	VHD2240	SCREW	1	
--	--	----	---------	-------	---	--

Model No. : DMC-TZ80/TZ81/ZS60 Parts List

Change	Safety	Ref. No.	Part No.	Part Name & Description	Q'ty	Remarks
		B7	VHD2240	SCREW	1	
		B8	VHD2371	SCREW	1	
		B9	VHD2239	SCREW	1	
		B10	VHD2239	SCREW	1	
		B11	VHD2369	SCREW	1	
		B12	VHD2369	SCREW	1	
		B13	VHD2369	SCREW	1	
		B14	VHD2369	SCREW	1	
		B15	VHD2369	SCREW	1	
		B16	VHD2369	SCREW	1	
		B17	VHD2369	SCREW	1	
		B18	VHD2369	SCREW	1	
		B19	VHD2369	SCREW	1	
		B20	VHD2369	SCREW	1	
		B21	VHD2432	SCREW	1	
		B22	VHD2457	SCREW	1	
		B23	VHD2457	SCREW	1	
		B24	VHD2457	SCREW	1	
		B25	VHD2457	SCREW	1	
		B26	VHD2457	SCREW	1	
		100	SXW0317	LENS UNIT (W/O MOS)	1	
		101	SEQ0133	MOS UNIT	1	
		101-1	SZT0250	HEAT RADIATION SHEET	1	
		102	VMB4601	TILT SPRING	1	
		103	VMB4601	TILT SPRING	1	
		104	VMB4601	TILT SPRING	1	
		105	SXW0065	FIX FRAME UNIT	1	
		106	VXP3972	1ST LENS FRAME UNIT	1	
		107	VXP3977	2ND LENS FRAME UNIT	1	
		108	SXW0063	BOTH SIDE CUM FRAME UNIT	1	
		109	VXP3978	3RD LENS FRAME UNIT	1	
		110	SXQ0667	MASTER FLANGE UNIT	1	
		111	SEQ0132	LENS FPC UNIT	1	
		112	SZT0247	LENS TAPE	1	
		B101	VHD2388	SCREW	1	
		B102	VHD2388	SCREW	1	
		B103	VHD2388	SCREW	1	
		B104	VHD2390	SCREW	1	
		B105	VHD2390	SCREW	1	
		B106	VHD2390	SCREW	1	
		B107	VHD2390	SCREW	1	
		B108	VHD2390	SCREW	1	
		B109	VHD2390	SCREW	1	
		B110	VHD2451	SCREW	1	
		B111	VHD2451	SCREW	1	
		B112	VHD2492	SCREW	1	
		B113	VHD2492	SCREW	1	
		201	SPF0014	BAG, BUBBLE WRAP	1	
		202	SPK0144	PACKING CASE	1	TZ80EG-K, EP-K, EF-K, EB-K, EE-K, GC-K, GA-K, GN-K
		202	SPU0132	PACKING CASE	1	TZ80EG-S, EP-S, EF-S, EB-S, EE-S, GA-S, GN-S
		202	SPU0201	PACKING CASE	1	GC-K
		202	SPK0146	PACKING CASE	1	TZ81EG-K
		202	SPU0134	PACKING CASE	1	TZ81EG-S
		202	SPK0143	PACKING CASE	1	P-K, PP-K
		202	SPU0131	PACKING CASE	1	P-S, PP-S
		202	SPK0145	PACKING CASE	1	GH-K
		202	SPU0133	PACKING CASE	1	GH-S
		203	SPF0065	CAMERA BAG	1	
		204	-----	BATTERY PACK	1	

		206	SAE0012DA	AC ADAPTOR	1	(TZ80/81) EG, EP, EF, EE, GA
--	---	-----	-----------	------------	---	------------------------------

Model No. : DMC-TZ80/TZ81/ZS60 Parts List

Change	Safety	Ref. No.	Part No.	Part Name & Description	Q'ty	Remarks
		206	SAE0012FA	AC ADAPTOR	1	EB, GH
		206	SAE0012HA	AC ADAPTOR	1	GC
		206	SAE0012GA	AC ADAPTOR	1	GN
		206	SAE0012AA	AC ADAPTOR	1	P, PP
		207	SQT1169	BASIC O/I (GERMAN)	1	(TZ80/81) EG
		207	SQT1170	BASIC O/I (FRENCH)	1	(TZ80/81) EG, EF
		207	SQT1171	BASIC O/I (ITALIAN)	1	TZ80EG
		207	SQT1172	BASIC O/I (DUTCH)	1	TZ80EG, EF
		207	SQT1173	BASIC O/I (SPANISH)	1	TZ80EG
		207	SQT1174	BASIC O/I (PORTUGUESE)	1	TZ80EG
		207	SQT1175	BASIC O/I (FINNISH)	1	EP
		207	SQT1176	BASIC O/I (DANISH)	1	EP
		207	SQT1177	BASIC O/I (SWEDISH)	1	EP
		207	SQT1178	BASIC O/I (POLISH)	1	EP
		207	SQT1179	BASIC O/I (CZECH)	1	EP
		207	SQT1180	BASIC O/I (HUNGARIAN)	1	EP
		207	SQT1181	BASIC O/I (ENGLISH)	1	EB
		207	SQT1182	BASIC O/I (RUSSIAN)	1	EE
		207	SQT1183	BASIC O/I (UKRAINIAN)	1	EE
		207	SQT1224	BASIC O/I (ENGLISH)	1	GC
		207	SQT1225	BASIC O/I (ARABIC)	1	GC
		207	SQT1184	BASIC O/I (ENGLISH)	1	GA, GH
		207	SQT1185	BASIC O/I (CHINESE (TRADITIONAL))	1	GA, GH
		207	SQT1189	BASIC O/I (ENGLISH)	1	GN
		207	SQT1166	BASIC O/I (ENGLISH)	1	P, PP
		207	SQT1167	BASIC O/I (FRENCH)	1	PP
		207	SQT1168	BASIC O/I (SPANISH)	1	P, PP
		208	K1HY04YY0106	USB CABLE	1	
		209	VFC4297-C	HAND STRAP	1	
		210	VPF1553	BAG, POLYETHYLENE	1	