

Service Manual

Digital Camera

LUMIX

LEICA DC VARIO-ELMAR



DMC-TZ2P
DMC-TZ2PC
DMC-TZ2PL
DMC-TZ2EB
DMC-TZ2EE
DMC-TZ2EF
DMC-TZ2EG
DMC-TZ2EGM
DMC-TZ2GC
DMC-TZ2GD
DMC-TZ2GK
DMC-TZ2GN
DMC-TZ2GT
DMC-TZ3P
DMC-TZ3PC
DMC-TZ3PL
DMC-TZ3EB
DMC-TZ3EE
DMC-TZ3EF
DMC-TZ3EG
DMC-TZ3EGM
DMC-TZ3GC
DMC-TZ3GD
DMC-TZ3GK
DMC-TZ3GN

Panasonic®

DMC-TZ3GT DMC-TZ3SG

Colour
 (S).....Silver Type
 (K).....Black Type (except DMC-TZ2PL/GD/GT)
 (A).....Blue Type
 (only DMC-TZ3P/PC/EB/EE/EF/EG/
 EGM/GC/SG)

Vol. 1

WARNING

This service information is designed for experienced repair technicians only and is not designed for use by the general public. It does not contain warnings or cautions to advise non-technical individuals of potential dangers in attempting to service a product. Products powered by electricity should be serviced or repaired only by experienced professional technicians. Any attempt to service or repair the product or products dealt with in this service information by anyone else could result in serious injury or death.

TABLE OF CONTENTS

	PAGE	PAGE
1 Safety Precaution	3	
1.1. General Guidelines	3	
1.2. Leakage Current Cold Check	3	
1.3. Leakage Current Hot Check (See Figure 1.)	3	
1.4. How to Discharge the Capacitor on Flash PCB	4	
2 Warning	5	
2.1. Prevention of Electrostatic Discharge (ESD) to Electrostatically Sensitive (ES) Devices	5	
2.2. How to Recycle the Lithium Ion Battery (U.S. Only)	5	
2.3. Caution for AC Cord (For EB/GC/SG)	6	
2.4. How to Replace the Lithium Battery	7	
3 Service Navigation	8	
3.1. Introduction	8	
3.2. General Description About Lead Free Solder (PbF)	8	
3.3. Important Notice 1: (Other than U.S.A. and Canadian Market)	8	
3.4. How to Define the Model Suffix (NTSC or PAL model)	9	
4 Specifications	12	
5 Location of Controls and Components	13	
6 Service Mode	15	
6.1. Error Code Memory Function	15	
6.2. Confirmation of Firmware Version	18	
7 Service Fixture & Tools	19	
7.1. Service Fixture and Tools	19	
7.2. When Replacing the Main PCB	20	
7.3. Service Position	20	
8 Disassembly and Assembly Instructions	22	
8.1. Disassembly Flow Chart	22	
8.2. PCB Location	22	
8.3. Disassembly Procedure	23	
8.4. Disassembly Procedure for the Lens	28	
8.5. Assembly Procedure for the Lens	31	
8.6. Removal of the CCD Unit	35	
8.7. Removal of the Zoom Motor Unit	35	
8.8. Removal of the Focus Motor Unit	36	
8.9. The Application of Grease Method	36	
9 Measurements and Adjustments	37	
9.1. Matrix Chart for Replaced Part and Necessary Adjustment	37	
10 Maintenance	38	
10.1. Cleaning Lens and LCD Panel	38	

1 Safety Precaution

1.1. General Guidelines

1. IMPORTANT SAFETY NOTICE

There are special components used in this equipment which are important for safety. These parts are marked by

 in the Schematic Diagrams, Circuit Board Layout, Exploded Views and Replacement Parts List. It is essential that these critical parts should be replaced with manufacturer's specified parts to prevent X-RADIATION, shock, fire, or other hazards. Do not modify the original design without permission of manufacturer.

2. An Isolation Transformer should always be used during the servicing of AC Adaptor whose chassis is not isolated from the AC power line. Use a transformer of adequate power rating as this protects the technician from accidents resulting in personal injury from electrical shocks. It will also protect AC Adaptor from being damaged by accidental shorting that may occur during servicing.
3. When servicing, observe the original lead dress. If a short circuit is found, replace all parts which have been overheated or damaged by the short circuit.
4. After servicing, see to it that all the protective devices such as insulation barriers, insulation papers shields are properly installed.
5. After servicing, make the following leakage current checks to prevent the customer from being exposed to shock hazards.

1.2. Leakage Current Cold Check

1. Unplug the AC cord and connect a jumper between the two prongs on the plug.
2. Measure the resistance value, with an ohmmeter, between the jumpered AC plug and each exposed metallic cabinet part on the equipment such as screwheads, connectors, control shafts, etc. When the exposed metallic part has a return path to the chassis, the reading should be between $1\text{ M}\Omega$ and $5.2\text{ M}\Omega$. When the exposed metal does not have a return path to the chassis, the reading must be infinity.

1.3. Leakage Current Hot Check (See Figure 1.)

1. Plug the AC cord directly into the AC outlet. Do not use an isolation transformer for this check.
2. Connect a $1.5\text{ k}\Omega$, 10 W resistor, in parallel with a $0.15\text{ }\mu\text{F}$ capacitor, between each exposed metallic part on the set and a good earth ground, as shown in Figure 1.
3. Use an AC voltmeter, with $1\text{ k}\Omega/\text{V}$ or more sensitivity, to measure the potential across the resistor.
4. Check each exposed metallic part, and measure the voltage at each point.
5. Reverse the AC plug in the AC outlet and repeat each of the above measurements.
6. The potential at any point should not exceed 0.75 V RMS . A leakage current tester (Simpson Model 229 or equivalent) may be used to make the hot checks, leakage current must not exceed $1/2\text{ mA}$. In case a measurement is outside of the limits specified, there is a possibility of a shock hazard, and the equipment should be repaired and rechecked before it is returned to the customer.

Hot-Check Circuit

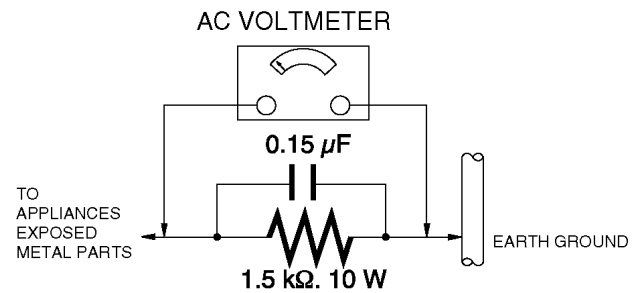

Figure. 1

1.4. How to Discharge the Capacitor on Flash PCB

CAUTION:

1. Be sure to discharge the capacitor on FLASH PCB.
2. Be careful of the high voltage circuit on FLASH PCB when servicing.

[Discharging Procedure]

1. Refer to the disassemble procedure and Remove the necessary parts/unit.
2. Put the insulation tube onto the lead part of Resistor (ERG5SJ102:1k Ω /5W).
(an equivalent type of resistor may be used.)
3. Put the resistor between both terminals of capacitor on FLASH PCB for approx. 5 seconds.
4. After discharging confirm that the capacitor voltage is lower than 10V using a voltmeter.

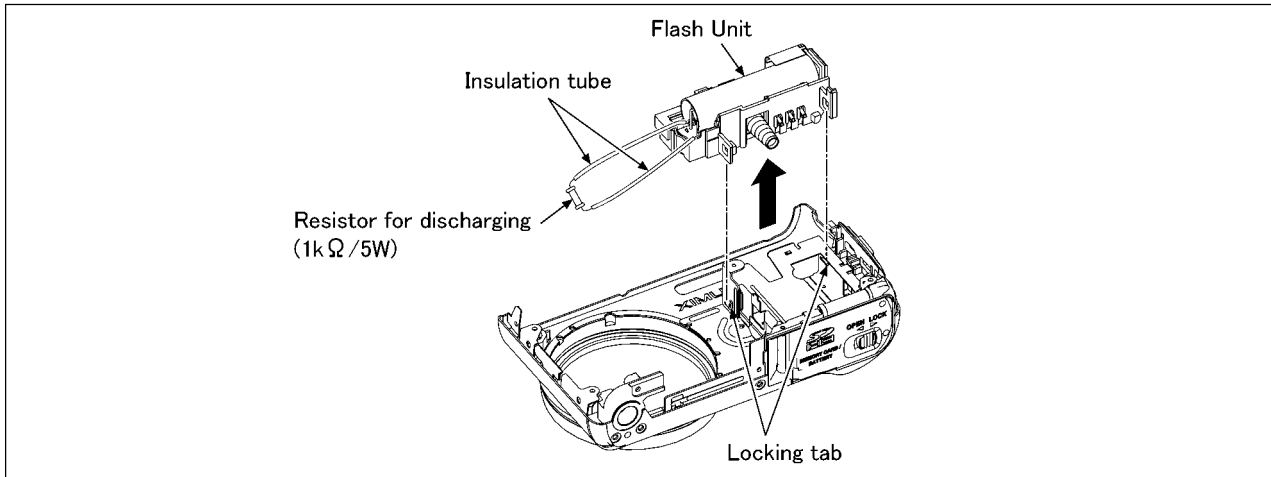

Fig. F1

2 Warning

2.1. Prevention of Electrostatic Discharge (ESD) to Electrostatically Sensitive (ES) Devices

Some semiconductor (solid state) devices can be damaged easily by static electricity. Such components commonly are called Electrostatically Sensitive (ES) Devices.

Examples of typical ES devices are CCD image sensor, IC (integrated circuits) and some field-effect transistors and semiconductor "chip" components.

The following techniques should be used to help reduce the incidence of component damage caused by electrostatic discharge (ESD).

1. Immediately before handling any semiconductor component or semiconductor-equipped assembly, drain off any ESD on your body by touching a known earth ground. Alternatively, obtain and wear a commercially available discharging ESD wrist strap, which should be removed for potential shock reasons prior to applying power to the unit under test.
2. After removing an electrical assembly equipped with ES devices, place the assembly on a conductive surface such as aluminum foil, to prevent electrostatic charge buildup or exposure of the assembly.
3. Use only a grounded-tip soldering iron to solder or unsolder ES devices.
4. Use only an antistatic solder removal device. Some solder removal devices not classified as "antistatic (ESD protected)" can generate electrical charge sufficient to damage ES devices.
5. Do not use freon-propelled chemicals. These can generate electrical charges sufficient to damage ES devices.
6. Do not remove a replacement ES device from its protective package until immediately before you are ready to install it. (Most replacement ES devices are packaged with leads electrically shorted together by conductive foam, aluminum foil or comparable conductive material).
7. Immediately before removing the protective material from the leads of a replacement ES device, touch the protective material to the chassis or circuit assembly into which the device will be installed.

CAUTION :

Be sure no power is applied to the chassis or circuit, and observe all other safety precautions.

8. Minimize bodily motions when handling unpackaged replacement ES devices. (Otherwise harmless motion such as the brushing together of your clothes fabric or the lifting of your foot from a carpeted floor can generate static electricity (ESD) sufficient to damage an ES device).

2.2. How to Recycle the Lithium Ion Battery (U.S. Only)

ENGLISH



A lithium ion/polymer battery that is recyclable powers the product you have purchased. Please call 1-800-8-BATTERY for information on how to recycle this battery.

FRANÇAIS



L'appareil que vous vous êtes procuré est alimenté par une batterie au lithium-ion/polymère recyclable. Pour des renseignements sur le recyclage de la batterie, veuillez composer le 1-800-8-BATTERY.

2.3. Caution for AC Cord (For EB/GC/SG)

2.3.1. Information for Your Safety

IMPORTANT

Your attention is drawn to the fact that recording of pre-recorded tapes or discs or other published or broadcast material may infringe copyright laws.

WARNING

To reduce the risk of fire or shock hazard, do not expose this equipment to rain or moisture.

CAUTION

To reduce the risk of fire or shock hazard and annoying interference, use the recommended accessories only.

FOR YOUR SAFETY

DO NOT REMOVE THE OUTER COVER

To prevent electric shock, do not remove the cover. No user serviceable parts inside. Refer servicing to qualified service personnel.

2.3.2. Caution for AC Mains Lead

For your safety, please read the following text carefully.

This appliance is supplied with a moulded three-pin mains plug for your safety and convenience.

A 5-ampere fuse is fitted in this plug.

Should the fuse need to be replaced please ensure that the replacement fuse has a rating of 5 amperes and it is approved by ASTA or BSI to BS1362

Check for the ASRA mark or the BSI mark on the body of the fuse.



If the plug contains a removable fuse cover you must ensure that it is refitted when the fuse is replaced.

If you lose the fuse cover, the plug must not be used until a replacement cover is obtained.

A replacement fuse cover can be purchased from your local Panasonic Dealer.

If the fitted moulded plug is unsuitable for the socket outlet in your home then the fuse should be removed and the plug cut off and disposed of safely.

There is a danger of severe electrical shock if the cut off plug is inserted into any 13-ampere socket.

If a new plug is to be fitted please observe the wiring code as shown below.

If in any doubt, please consult a qualified electrician.

2.3.2.1. Important

The wires in this mains lead are coloured in accordance with the following code:

Blue	Neutral
Brown	Live

As the colours of the wires in the mains lead of this appliance may not correspond with the coloured markings identifying the terminals in your plug, proceed as follows:

The wire which is coloured BLUE must be connected to the terminal in the plug which is marked with the letter N or coloured BLACK.

The wire which is coloured BROWN must be connected to the terminal in the plug which is marked with the letter L or coloured RED.

Under no circumstances should either of these wires be connected to the earth terminal of the three pin plug, marked with the letter E or the Earth Symbol.



2.3.2.2. Before Use

Remove the Connector Cover as follows.



2.3.2.3. How to Replace the Fuse

1. Remove the Fuse Cover with a screwdriver.



2. Replace the fuse and attach the Fuse cover.



2.4. How to Replace the Lithium Battery

2.4.1. Replacement Procedure

1. Remove the Top Operation PCB. (Refer to Disassembly Procedures.)
2. Remove the Lithium battery (Ref. No. "B9901" at component side of Top Operation PCB) and then replace it into new one.

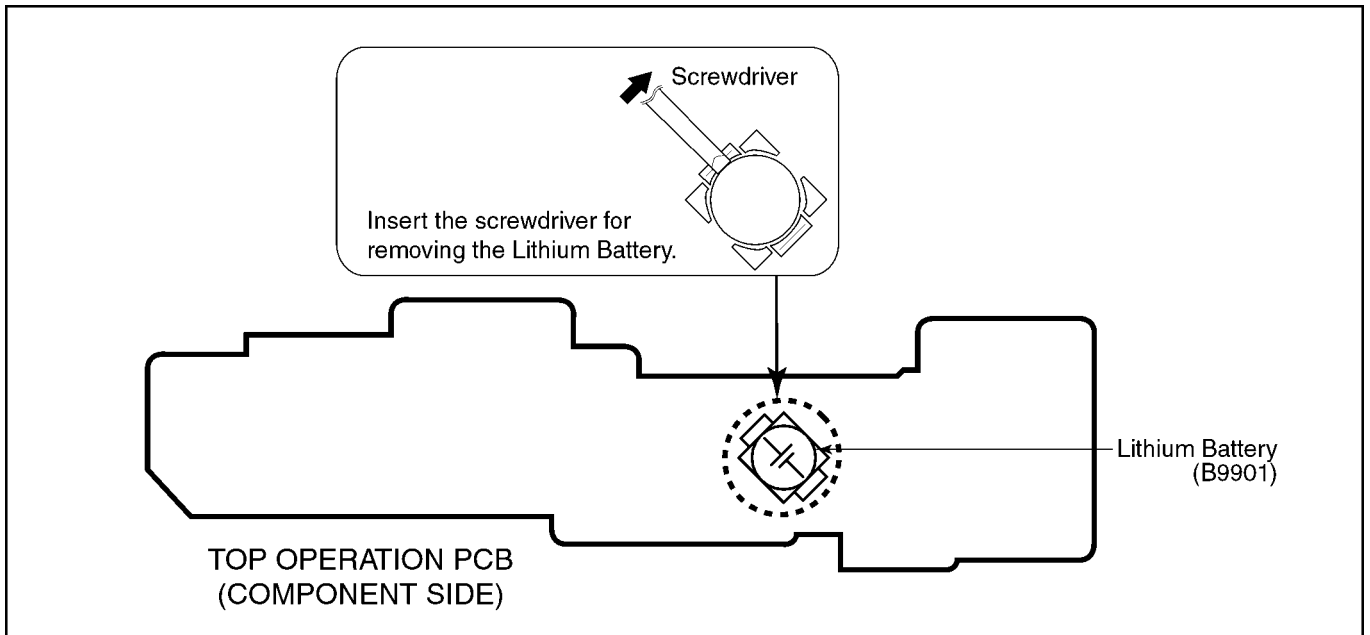

NOTE:

This Lithium battery is a critical component.

(Type No.: ML614S/ZT **Manufactured by Matsushita Battery Industrial Co.,Ltd.**)

It must never be subjected to excessive heat or discharge.

It must therefore only be fitted in requirement designed specifically for its use.

Replacement batteries must be of same type and manufacture.

They must be fitted in the same manner and location as the original battery, with the correct polarity contacts observed.

Do not attempt to re-charge the old battery or re-use it for any other purpose.

It should be disposed of in waste products destined for burial rather than incineration.

(For English)

CAUTION

Danger of explosion if battery is incorrectly replaced.

Replace only with the same or equivalent type recommended by the manufacturer.

Dispose of used batteries according to the manufacturer's instructions.

(For German)

ACHTUNG

Explosionsgefahr bei falschem Anbringen der Batterie. Ersetzen Sie nur mit einem äquivalentem vom Hersteller empfohlenem Typ.

Behandeln Sie gebrauchte Batterien nach den Anweisungen des Herstellers.

(For French)

MISE EN GARDE

Une batterie de remplacement inappropriée peut exploser. Ne remplacez qu'avec une batterie identique ou d'un type recommandé par le fabricant. L'élimination des batteries usées doit être faite conformément aux instructions du manufacturier.

NOTE:

Above caution is applicable for a battery pack which is for DMC-TZ3/TZ2 series, as well.

3 Service Navigation

3.1. Introduction

This service manual contains technical information, which allow service personnel's to understand and service this model. Please place orders using the parts list and not the drawing reference numbers. If the circuit is changed or modified, the information will be followed by service manual to be controlled with original service manual.

3.2. General Description About Lead Free Solder (PbF)

The lead free solder has been used in the mounting process of all electrical components on the printed circuit boards used for this equipment in considering the globally environmental conservation. The normal solder is the alloy of tin (Sn) and lead (Pb). On the other hand, the lead free solder is the alloy mainly consists of tin (Sn), silver (Ag) and Copper (Cu), and the melting point of the lead free solder is higher approx.30°C (86°F) more than that of the normal solder.

Distinction of PCB Lead Free Solder being used

The letter of "PbF" is printed either foil side or components side on the PCB using the lead free solder.(See right figure)	PbF
---	-----

Service caution for repair work using Lead Free Solder (PbF)

- The lead free solder has to be used when repairing the equipment for which the lead free solder is used. (Definition: The letter of "PbF" is printed on the PCB using the lead free solder.)
- To put lead free solder, it should be well molten and mixed with the original lead free solder.
- Remove the remaining lead free solder on the PCB cleanly for soldering of the new IC.
- Since the melting point of the lead free solder is higher than that of the normal lead solder, it takes the longer time to melt the lead free solder.
- Use the soldering iron (more than 70W) equipped with the temperature control after setting the temperature at 350±30°C (662±86°F).

Recommended Lead Free Solder (Service Parts Route.)

- The following 3 types of lead free solder are available through the service parts route.
 - RFKZ03D01K----- (0.3mm 100g Reel)
 - RFKZ06D01K----- (0.6mm 100g Reel)
 - RFKZ10D01K----- (1.0mm 100g Reel)

Note

* Ingredient: tin (Sn) 96.5%, silver (Ag) 3.0%, Copper (Cu) 0.5%, Cobalt (Co) / Germanium (Ge) 0.1 to 0.3%

3.3. Important Notice 1:(Other than U.S.A. and Canadian Market)

1. The service manual does not contain the following information, because of the impossibility of servicing at component level without concerned equipment/facilities.
 - a. Schematic diagram, Block Diagram and PCB layout of MAIN PCB.
 - b. Parts list for individual parts for MAIN PCB.When a part replacement is required for repairing MAIN PCB, replace as an assembled parts. (Main PCB)
2. The following category is/are recycle module part. please send it/them to Central Repair Center.
 - MAIN PCB (TZ3: VEP56047A/TZ2: VEP56047B)

3.4. How to Define the Model Suffix (NTSC or PAL model)

There are seven kinds of DMC-TZ3/TZ2, regardless of the colours.







- a) DMC-TZ3S
- b) DMC-TZ3, TZ2P/PC
- c) DMC-TZ3, TZ2EB/EF/EG/EGM/GN
- d) DMC-TZ3, TZ2EE
- e) DMC-TZ3, TZ2GD
- f) DMC-TZ3, TZ2GT
- g) DMC-TZ3PL/GC/GK/SG, TZ2PL/GC/GK

(DMC-TZ3S is exclusively Japan domestic model.)

What is the difference is that the "INITIAL SETTINGS" data which is stored in Flash ROM mounted on Main PCB.

3.4.1. Defining methods:

To define the model suffix to be serviced, refer to the nameplate which is putted on the bottom side of the Unit.

<p>a) DMC-TZ3S DMC-TZ3S is exclusively Japan domestic model.</p> <p>b) DMC-TZ3,TZ2P/PC The nameplate for these models show the following Safty registration mark.</p> <div style="border: 1px solid black; padding: 5px; text-align: center;">  </div> <p>c) DMC-TZ3,TZ2EB/EF/EG/EGM/GN The nameplate for these models show the following Safty registration mark.</p> <div style="border: 1px solid black; padding: 5px; text-align: center;">  </div> <p>d) DMC-TZ3,TZ2EE The nameplate for these models show the following Safty registration mark.</p> <div style="border: 1px solid black; padding: 5px; text-align: center;">  </div> <p>e) DMC-TZ3,TZ2GD The nameplate for these models show the following Safty registration mark.</p> <div style="border: 1px solid black; padding: 5px; text-align: center;">  </div> <p>f) DMC-TZ3,TZ2GT The nameplate for these models show the following Safty registration mark.</p> <div style="border: 1px solid black; padding: 5px; text-align: center;">  </div> <p>g) DMC-TZ3PL/GC/GK/SG, TZ2PL/GC/GK The nameplate for these models do not show any above Safty registration mark.</p>	 <p style="text-align: center; border: 1px solid black; padding: 2px;">Safty registration mark</p>
---	---

NOTE:

After replacing the MAIN PCB, be sure to achieve adjustment.

The adjustment instruction is available at "software download" on the "Support Information from NWBG/VDBG-PAVC" web-site in "TSN system", together with Maintenance software.

3.4.2. INITIAL SETTINGS:

When you replace the Main PCB, be sure to perform the initial settings after achieving the adjustment by ordering the following procedure in accordance with model suffix of the unit.

1. IMPORTANT NOTICE:

Before proceeding Initial settings, be sure to read the following CAUTIONS.

CAUTION 1 (Initial Settings)

DO NOT select "NONE(JAPAN)" or "P"(North America) if need to select "EG/EGM/PL/GD/GC/SG/GT/GK/EF/EB/EE/GN and PC".
Otherwise, once "NONE(JAPAN)" or "P"(North America) are selected, "EG/EGM/PL/GD/GC/SG/GT/GK/EF/EB/EE/GN and PC" will not displayed, thus, RE-Settings (changing area) can not be made.

CAUTION 2 (Picture back up from "Built-in Memory")

This unit employs "Built-in Memory" for picture image data recording.(Approx. 12.7 MB)
Be sure to make picture data back up (i.e., Copying to SD memory card), before proceeding "INITIAL SETTINGS".
Once "INITIAL SETTINGS" has been carried out, all image data stored at "Built-in Memory" is erased.

2. PROCEDURES:

- Preparation. Proceed the picture back up from the unit (Refer to above "CAUTION 2")
- **Step 1. The temporary cancellation of factory setting:**
Set the mode dial to "[Normal picture mode] (Red camera mark)".
While keep pressing [Optical Image Stabilizer] and "[UP] of Cross key" simultaneously, turn the Power on.
- **Step 2. The cancellation of factory setting:**
Set the mode dial to "[Playback]".
Press [Optical Image Stabilizer] and "[UP] of Cross key" simultaneously, then turn the Power off.
- **Step 3. Turn the Power on:**
Set the mode dial to "[Normal picture mode] (Red camera mark)", and then turn the Power on.
- **Step 4. Display the INITIAL SETTING:**
While keep pressing [MENU] and "[RIGHT] of Cross key" simultaneously, turn the Power off.

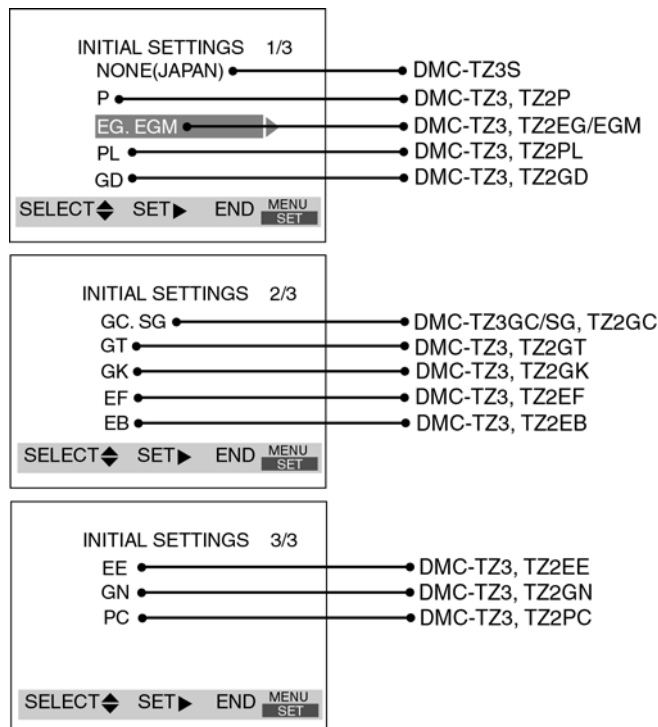

• **Step 5. Set the INITIAL SETTING: (Refer to “CAUTION 1”)**

[Caution for before settings]

Once "NONE(JAPAN)" (Area for Japan) or "P" (Area for North America) is selected with "INITIAL SETTINGS", other areas will not displayed even if "INITIAL SETTINGS" menu is displayed again, thus, the area can not be changed.

Select the area carefully.

Select the area with pressing “[UP] / [DOWN] of Cross key”, and then press the “[RIGHT] of Cross key”.

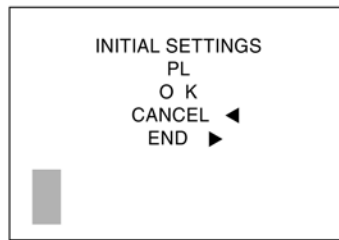

The only set area is displayed, and then press the “[RIGHT] of Cross key” after confirmation.

(The unit is powered off automatically.)

Confirm the display of “PLEASE SET THE CLOCK” in English when the unit is turned on again.

• **Step 6. CONFIRMATION:**

The display shows “PLEASE SET THE CLOCK” when turn the Power on again.

When the unit is connected to PC with USB cable, it is detected as removable media.

(When the “GT” or “GK” model suffix is selected, the display shows “PLEASE SET THE CLOCK” in Chinese.)

1) As for your reference Default setting condition is given in the following table.

• **Default setting (After “INITIAL SETTINGS”)**

	MODEL	VIDEO OUTPUT	LANGUAGE	DATE	REMARKS
a)	DMC-TZ3S	NTSC	Japanese	Year/Month/Date	
b)	DMC-TZ3, TZ2P/PC/PL	NTSC	English	Month/Date/Year	
c)	DMC-TZ3EB/EG/EGM/GC/GN/SG DMC-TZ2EB/EG/EGM/GC/GN	PAL	English	Date/Month/Year	
d)	DMC-TZ3, TZ2EF	PAL	French	Date/Month/Year	
e)	DMC-TZ3, TZ2EE	PAL	Russian	Date/Month/Year	
f)	DMC-TZ3, TZ2GK	PAL	Chinese (simplified)	Year/Month/Date	
g)	DMC-TZ3, TZ2GT	NTSC	Chinese (traditional)	Year/Month/Date	
h)	DMC-TZ3, TZ2GD	NTSC	Korean	Year/Month/Date	

4 Specifications

Digital Camera: Information for your safety

Power Source	DC 5.1 V
Power Consumption	When recording: 1.7 W (DMC-TZ3)/1.4 W (DMC-TZ2) When playing back: 0.8 W
Camera effective pixels	● DMC-TZ3: 7,200,000 pixels ● DMC-TZ2: 6,000,000 pixels
Image sensor	● DMC-TZ3: 1/2.35" CCD, total pixel number 8,500,000 pixels ● DMC-TZ2: 1/2.33" CCD, total pixel number 7,390,000 pixels Primary color filter
Lens	Optical 10 x zoom f=4.6 mm to 46 mm (35 mm film camera equivalent: 28 mm to 280 mm)/F3.3 to F4.9
Digital zoom	Max. 4 x
Extended optical zoom	Max. 15 x (DMC-TZ3)/Max. 13.8 x (DMC-TZ2)
Focus	Normal/Macro 9-area-focusing/3-area-focusing (High speed)/ 1-area-focusing (High speed)/1-area-focusing/Spot-focusing
Focus range	Normal 50 cm (1.64 feet) (Wide)/2 m (6.56 feet) (Tele) to ∞ Macro/Simple/Motion picture/ Intelligent ISO/Clipboard 5 cm (0.16 feet) (Wide)/1 m (3.28 feet) (Tele) to ∞ (2 m (6.56 feet) unless max.T)
Scene mode	There may be difference in above settings.
Shutter system	Electronic shutter + Mechanical shutter
Motion picture recording	848 × 480 pixels*/640 × 480 pixels* /320 × 240 pixels (*Only when using an SD Memory Card) (30 or 10 frames/second with audio. The maximum recording time depends on the capacity of the built-in memory or the card.)
Burst recording	
Burst speed	● DMC-TZ3: 3 frames/second (High speed), 2 frames/second (Low speed), Approx. 2 frames/second (Unlimited) ● DMC-TZ2: Approx. 2 frames/second (Unlimited)
Number of recordable pictures	● DMC-TZ3: Max. 7 frames (Standard), max. 5 frames (Fine). Depends on the remaining capacity of the built-in memory or the card (Unlimited). ● DMC-TZ2: Depends on the remaining capacity of the built-in memory or the card.
ISO sensitivity	AUTO/100/200/400/800/1250 [HIGH SENS.] mode: 3200
Shutter speed	8 to 1/2000th [STARRY SKY] mode: 15 seconds, 30 seconds, 60 seconds Motion picture mode: 1/30th to 1/20000th
White balance	AUTO/Daylight/Cloudy/Shade/Halogen/White set
Exposure (AE)	AUTO (Program AE) Exposure compensation (1/3 EV Step, -2 EV to +2 EV)
Metering mode	Multiple/Center weighted/Spot
LCD monitor	● DMC-TZ3: 3.0" low-temperature polycrystalline TFT LCD (Approx. 230,000 pixels) (field of view ratio about 100%) ● DMC-TZ2: 2.5" low-temperature polycrystalline TFT LCD (Approx. 207,000 pixels) (field of view ratio about 100%)
Flash	Flash range: (ISO AUTO) Approx.60 cm (1.97 feet) to 4.2 m (13.8 feet) (Wide) AUTO, AUTO/Red-eye reduction, Forced flash ON (Forced flash ON/ Red-eye reduction), Slow sync/Red-eye reduction, Forced OFF

Microphone	Monaural
Speaker	Monaural
Recording media	Built-in Memory (Approx. 12.7 MB)/SD Memory Card/SDHC Memory Card/ MultiMediaCard (Still pictures only)
Picture size	
Still picture	When the aspect ratio setting is [4:3] ● DMC-TZ3: 3072 × 2304 pixels / 2560 × 1920 pixels / 2048 × 1536 pixels / 1600 × 1200 pixels / 1280 × 960 pixels / 640 × 480 pixels ● DMC-TZ2: 2816 × 2112 pixels / 2048 × 1536 pixels / 1600 × 1200 pixels / 1280 × 960 pixels / 640 × 480 pixels
Motion pictures (*Only when using an SD Memory Card)	When the aspect ratio setting is [16:9] ● DMC-TZ3: 3216 × 2144 pixels / 2560 × 1712 pixels / 2048 × 1360 pixels ● DMC-TZ2: 2976 × 1984 pixels / 2560 × 1712 pixels / 2048 × 1360 pixels
Quality	Fine/Standard
Recording file format	
Still Picture	JPEG (based on Design rule for Camera File system, based on Exif 2.21 standard)/DPOF corresponding
Still pictures with audio	JPEG (based on Design rule for Camera File system, based on Exif 2.21 standard) + QuickTime
Motion pictures	QuickTime Motion JPEG
Interface	Digital: USB 2.0 (Full Speed) Analog video/audio: NTSC/PAL Composite (Switched by menu)/Audio line output (monaural)
Terminal	DIGITAL/AV OUT: Dedicated jack (8 pin) DC IN: Dedicated jack (2 pin)
Dimensions (excluding the projection part)	● DMC-TZ3: Approx. 105.0 mm (W) × 59.2 mm (H) × 36.7 mm (D) [4.13" (W) × 2.33" (H) × 1.44" (D)] ● DMC-TZ2: Approx. 105.0 mm (W) × 59.2 mm (H) × 36.3 mm (D) [4.13" (W) × 2.33" (H) × 1.43" (D)]
Mass	Excluding card and battery: DMC-TZ3 Approx. 232 g (8.18 oz)/ DMC-TZ2 Approx. 222 g (7.83 oz) With card and battery: DMC-TZ3 Approx. 257 g (9.06 oz)/ DMC-TZ2 Approx. 247 g (8.71 oz)
Operating temperature	0 °C to 40 °C (32 °F to 104 °F)
Operating humidity	10 % to 80 %
Battery charger (Panasonic DE-A45B): Information for your safety	
Output	CHARGE 4.2 V = 0.8 A
Input	110 V to 240 V 50/60Hz, 0.2 A
Equipment mobility: Movable	
Battery Pack (lithium-ion) (Panasonic CGA-S007A): Information for your safety	
Voltage/capacity	3.7 V 1000 mAh

5 Location of Controls and Components

Names of parts

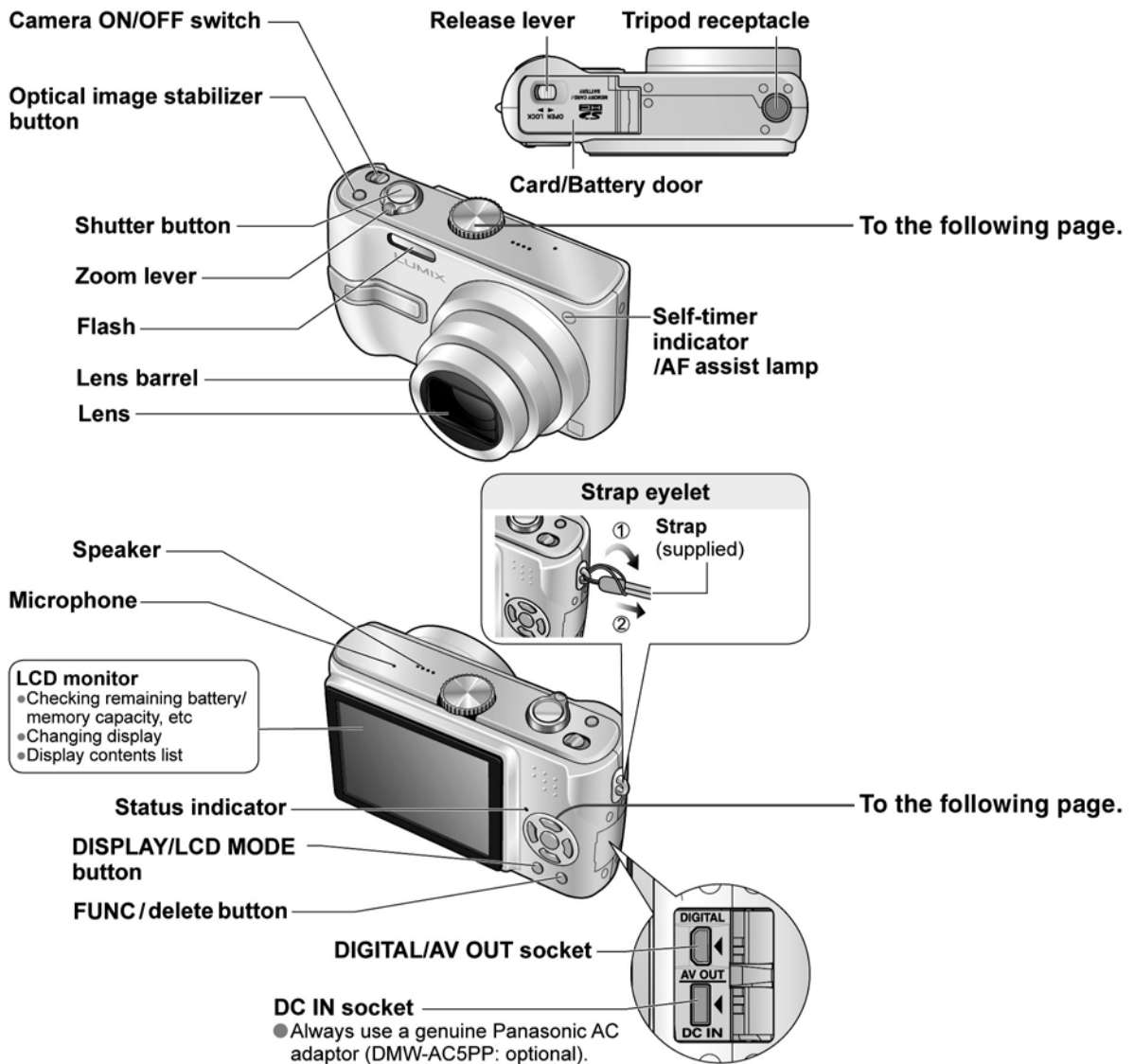

From the previous page.

Mode dial

Align to correct mode →

(Displayed on screen when mode changed)

<p> NORMAL PICTURE mode Take pictures.</p> <p> INTELLIGENT ISO mode Take pictures according to motion and brightness of subject.</p> <p> PLAYBACK mode View/edit pictures previously taken.</p> <p> SIMPLE MODE For beginners.</p>	<p>SCN1 SCENE mode SCN2 Take pictures according to scene.</p> <p> CLIPBOARD mode Take/view pictures as memos.</p> <p> PRINT mode Print.</p> <p> MOTION PICTURE mode Take motion pictures.</p> <p> MACRO mode Take close-up pictures.</p>
--	---

From the previous page.

Up/down/left/right selection

Self-timer

- Exposure compensation
- Auto bracket *
- White balance fine adjustment
- Backlight compensation
- Flash

MENU/SET (menu display/set)

REV

View previously taken picture immediately (Review)

* DMC-TZ3 only

6 Service Mode

6.1. Error Code Memory Function

1. General description

This unit is equipped with history of error code memory function, and can be memorized 16 error codes in sequence from the latest. When the error is occurred more than 16, the oldest error is overwritten in sequence.

The error code is not memorized when the power supply is shut down forcibly (when the unit is powered on by the battery, the battery is pulled out) because the error code is memorized to FLASH ROM when the unit is powered off.

2. How to display

The error code can be displayed by the following procedure:

Before perform the error code memory function, connect the AC adaptor or insert the battery.

(Since this unit has built-in memory, this error code memory function can be performed without inserting SD card.)

- **1. The temporary cancellation of factory setting:**

Set the mode dial to “[Normal picture mode] (Red camera mark)”.

While keep pressing [Optical Image Stabilizer Button] and “[UP] of Cross key” simultaneously, turn the Power on.

- **2. The display of error code:**

Press [Optical Image Stabilizer Button], [MENU] and “[LEFT] of Cross key” simultaneously with the step 1 condition.

The display is changed as shown below when the above buttons is pressed simultaneously.

Normal display → Error code display → Operation history display → Normal display →

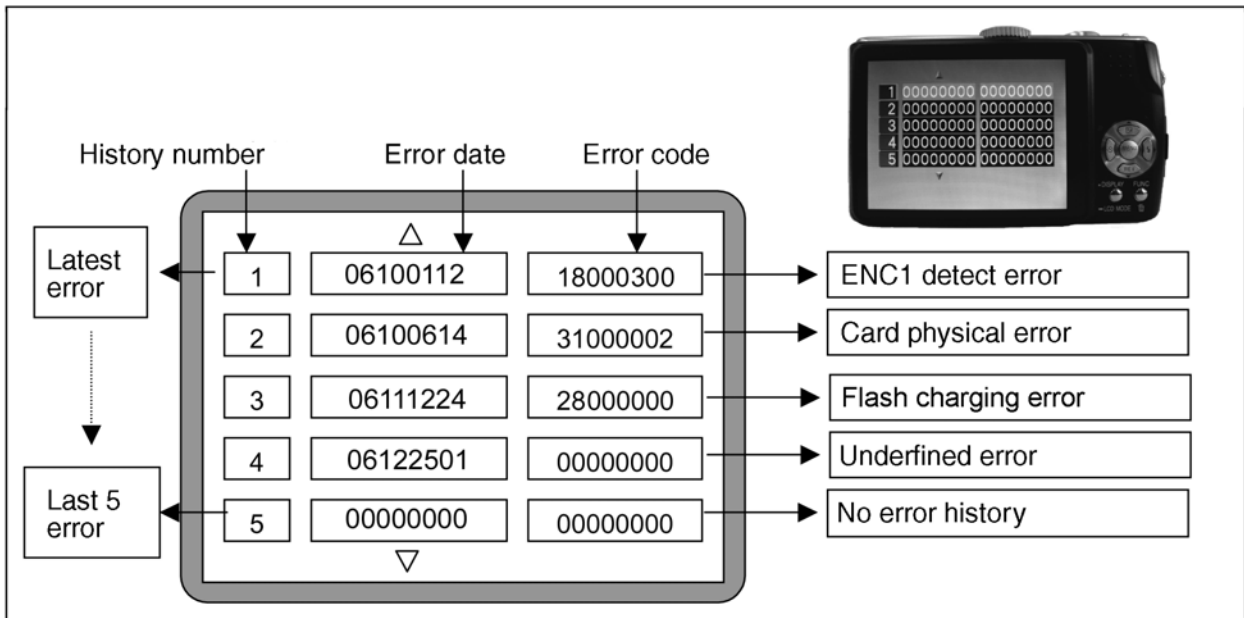

Example of Error Code Display

- **3. The change of display:**

The error code can be memorized 16 error codes in sequence, however it is displayed 5 errors on the LCD.

Display can be changed by the following procedure:

“[UP] or [DOWN] of Cross key” : It can be scroll up or down one.

“[LEFT] or [RIGHT] of Cross key” : It can be display last 5 error or another 5 error.

- **4. How to read the error date:**

The error date code is displayed from the left in order at the month, year, day, time.

Error date information is acquired from "Clock setting" information when the error occurs. When the clock is not setting, it is displayed as "00000000".

• 5. How to read the error code:

One error code is displayed for 8 bit, the contents of error codes is indicated the table as shown below.

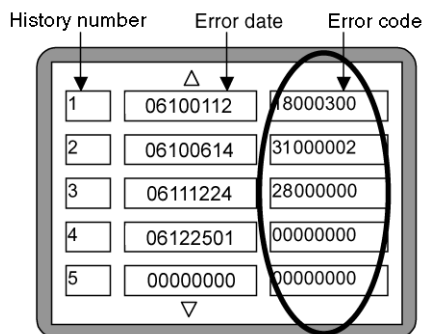

Attribute	Main item	Sub item	Error code		Contents (Upper)	
			High 4 bits	Low 4 bits	Check point (Lower)	
LENS	Lens drive	OIS	18*0	1000	PSD (X) error. Hall element (X axis) position detect error in OIS unit. OIS Unit	
				2000	PSD (Y) error. Hall element (Y axis) position detect error in OIS unit. OIS Unit	
				3000	GYRO (X) error. Gyro (IC7201: X axis) detect error on Main P.C.B.. IC7201 (Gyro element) or IC6001 (VENUS 3)	
				4000	GYRO (Y) error. Gyro (IC7201: Y axis) detect error on Main P.C.B.. IC7201 (Gyro element) or IC6001 (VENUS 3)	
				5000	MREF error (Reference voltage error). IC7001 (LENS drive) or IC6001 (VENUS 3)	
				6000	Drive voltage (X) error. VENUS 3 AD value error, LENS Unit, LENS flex breaks etc.	
				7000	Drive voltage (Y) error. VENUS 3 AD value error, LENS Unit, LENS flex breaks etc.	
		C.B./Zoom	0100	HP Low detect error (C.B. encoder (full retract) always Low detect). FP9802-(15,16) signal line or IC6001 (VENUS 3)		
			0200	HP High detect error (C.B. encoder (full retract) always High detect). FP9802-(13,14) signal line or IC6001 (VENUS 3)		
			0300	ENC1 detect error (C.B. motor encoder detect error). FP9802-(10) signal line or IC6001 (VENUS 3)		
			0400	ENC2 detect error (C.B. motor encoder detect error). FP9802-(8) signal line or IC6001 (VENUS 3)		
			Focus	0001	HP Low detect error (Focus encoder always Low detect error). FP9802-(11) signal line or IC6001 (VENUS 3)	
				0002	HP High detect error (Focus encoder always High detect error). FP9802-(9) signal line or IC6001 (VENUS 3)	
		Lens	18*1	0000	Power ON time out error. Lens drive system	
				18*2	0000	Power OFF time out error. Lens drive system
		Adj.History	OIS	19*0	2000	OIS adj. Yaw direction amplitude error (small)
					3000	OIS adj. Pitch direction amplitude error (small)
					4000	OIS adj. Yaw direction amplitude error (large)
					5000	OIS adj. Pitch direction amplitude error (large)
	6000				OIS adj. MREF error	
	7000				OIS adj. time out error	
	8000				OIS adj. Yaw direction off set error	
	9000				OIS adj. Pitch direction off set error	
A000	OIS adj. Yaw direction gain error					
B000	OIS adj. Pitch direction gain error					
C000	OIS adj. Yaw direction position sensor error					
D000	OIS adj. Pitch direction position sensor error					
E000	OIS adj. other error					

Attribute	Main item	Sub item	Error code		Contents (Upper)
			High 4 bits	Low 4 bits	Check point (Lower)
HARD	VENUS A/D	Flash	28*0	0000	Flash charging error. IC6001-(247) signal line or Flash charging circuit
	FLASH ROM (EEPROM Area)	FLASH ROM (EEPROM Area)	2B*0	0001	EEPROM read error IC6002 (FLASH ROM)
				0002	EEPROM write error IC6002 (FLASH ROM)
	SYSTEM	RTC	2C*0	0001	SYSTEM IC initialize failure error Communication between IC6001 (VENUS 3) and IC9101 (SYSTEM)
SOFT	CPU	Reset	30*0	0001	NMI reset
				0007	Non Mask-able Interrupt (30000001-30000007 are caused by factors)
	Card	Card	31*0	0001	Card logic error SD memory card data line or IC6001 (VENUS 3)
				0002	Card physical error SD memory card data line or IC6001 (VENUS 3)
				0004	Write error SD memory card data line or IC6001 (VENUS 3)
				39*0	0005
	CPU, ASIC hard	Stop	38*0	0001	Camera task finish process time out. Communication between Lens system and IC6001 (VENUS 3)
				0002	Camera task invalid code error. IC6001 (VENUS 3)
				0100	File time out error in recording motion image IC6001 (VENUS 3)
				0200	File data send error in recording motion image IC6001 (VENUS 3)
				0300	Single or burst recording brake time out.
	Operation	Power on	3B*0	0000	FLASHROM processing early period of camera during movement.
	Zoom	Zoom	3C*0	0000	Inperfect zoom lens processing. Zoom lens
				35*0	0001
			35*1	0000	Though record preprocessing is necessary, it is not called.
			35*2	0000	Though record preprocessing is necessary, it is not completed.

About "*" display in the above table:

The treble of the error code is different according to the factory setting.

- In case of 0 (example: 18001000)

The error that occurs while factory settings completed is shown.

It is guessed the error that occurs basically on the user side.

- In case of 8 (example: 18801000)

The error that occurs while factory settings release is shown. (example: service mode etc.)

It is not an error that occurs on the user side.

• 6. How to returned to Normal Display:

Turn the power off and on, to exit from Error code display mode.

NOTE:

The error code can not be initialized.

6.2. Confirmation of Firmware Version

The Firmware version can be confirmed by ordering the following steps:

- **Step 1. The temporary cancellation of factory setting:**

Set the mode dial to “[Normal picture mode] (Red camera mark)”.

Insert the SD memory card which has a few photo data.

While keep pressing [Optical Image Stabilizer] and “[UP] of Cross key” simultaneously, then turn the power on.

- **Step 2. Confirm the version:**

Set the mode dial to “[Playback]” and then press [DISPLAY] to switch to LCD with indication. (Fig. A)

Press [Optical Image Stabilizer] and “[DOWN] of Cross key” simultaneously. (No need to keep pressing.)

(The version information is displayed on the LCD with light blue colour letters.) (Fig. B)

CAUTION:

The version information does not display if the LCD has switched to LCD with indication already.

In this case, press [DISPLAY] to switch to LCD with indication.

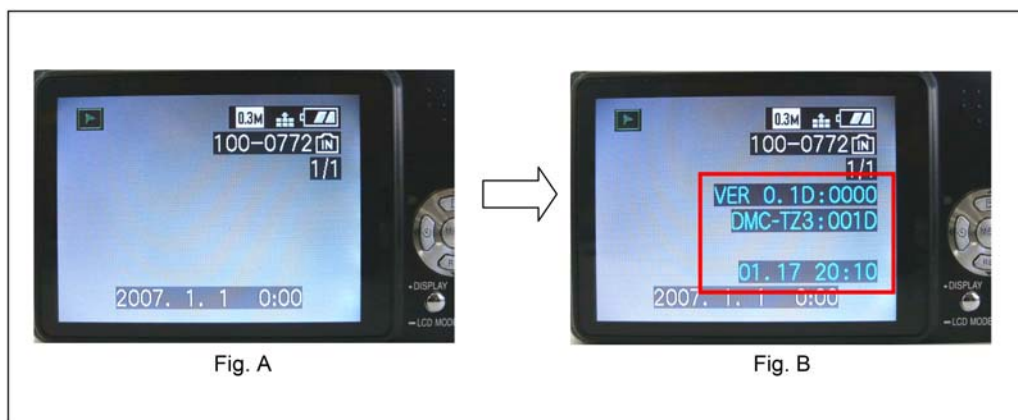
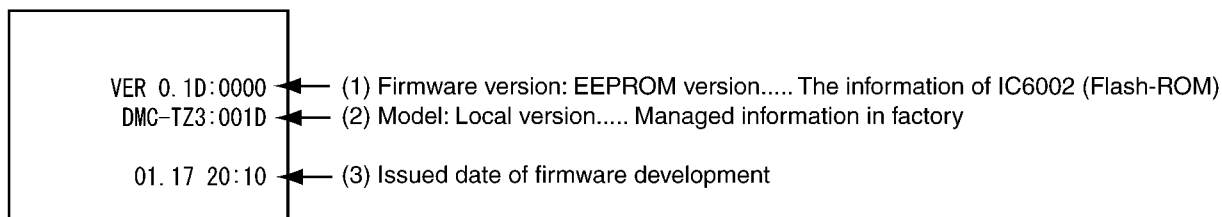





<Point>

- The firmware version and EEPROM version can be confirmed with the information (1).
- The information (2), (3) are just reference.

7 Service Fixture & Tools

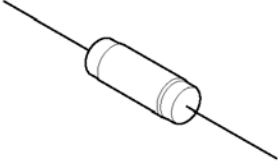
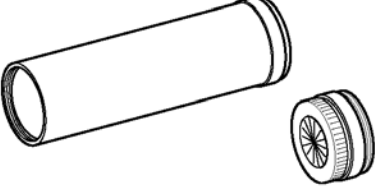
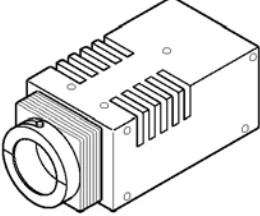
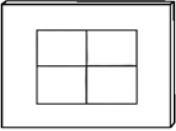
7.1. Service Fixture and Tools

The following Service Fixture and tools are used for checking and servicing this unit.

Resistor for Discharging ERG5SJ102	Infinity Lens (with Focus Chart) VFK1164TCM02	LIGHT BOX VFK1164TDVLB
 An equivalent type of Resistor may be used.		 ※ with DC Cable
TR Chart VFK1975	Lens Cleaning Kit (BK) VFK1900BK	Grease (for lens) VFK1829
	 * Only supplied as 10 set/box.	
Furoyl grease (for focus motor) VFK1850		
		

7.2. When Replacing the Main PCB

After replacing the MAIN PCB, be sure to achieve adjustment.

The adjustment instruction is available at "software download" on the "Support Information from NWBG/VDBG-PAVC" web-site in "TSN system", together with Maintenance software.

7.3. Service Position

This Service Position is used for checking and replacing parts. Use the following Extension cables for servicing.

Table S1 Extension Cable List

No.	Parts No.	Connection	Form
1	VFK1950	FP9801 (MAIN) - CCD UNIT	33PIN 0.3 FFC
2	RFKZ0416	FP9802 (MAIN) - LENS UNIT	41PIN 0.3 FFC
3	RFKZ0363	FP9803 (SUB) - FP9901 (FLASH)	19PIN 0.5 FFC
4	RFKZ0363	FP9005 (MAIN) - FP8001 (TOP OPERATION)	19PIN 0.5 FFC
5	RFKZ0363	FP9001 (MAIN) - LCD UNIT (For DMC-TZ3)	19PIN 0.5 FFC
		FP9002 (MAIN) - LCD UNIT (For DMC-TZ2)	
6	VFK1974	FP9003 (MAIN) - LCD UNIT (For DMC-TZ3)	4PIN 0.5 FFC
		FP9004 (MAIN) - LCD UNIT (For DMC-TZ2)	
		PS9801 (SUB) - PP9001 (MAIN)	
7	RFKZ0362	PS9801 (SUB) - PP9001 (MAIN)	100PIN B to B

7.3.1. Extension Cable Connections for DMC-TZ3

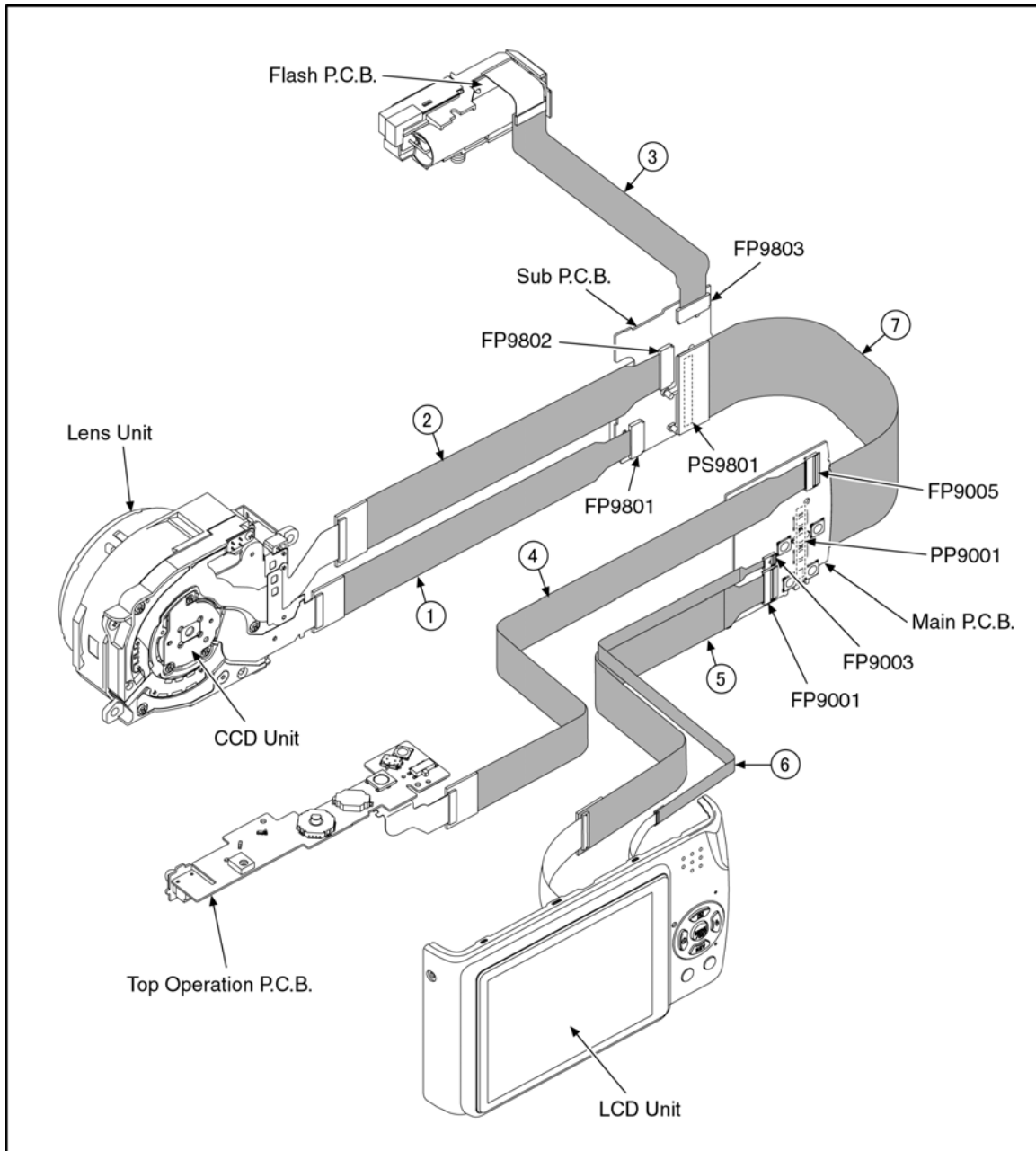

7.3.2. Extension Cable Connections for DMC-TZ2

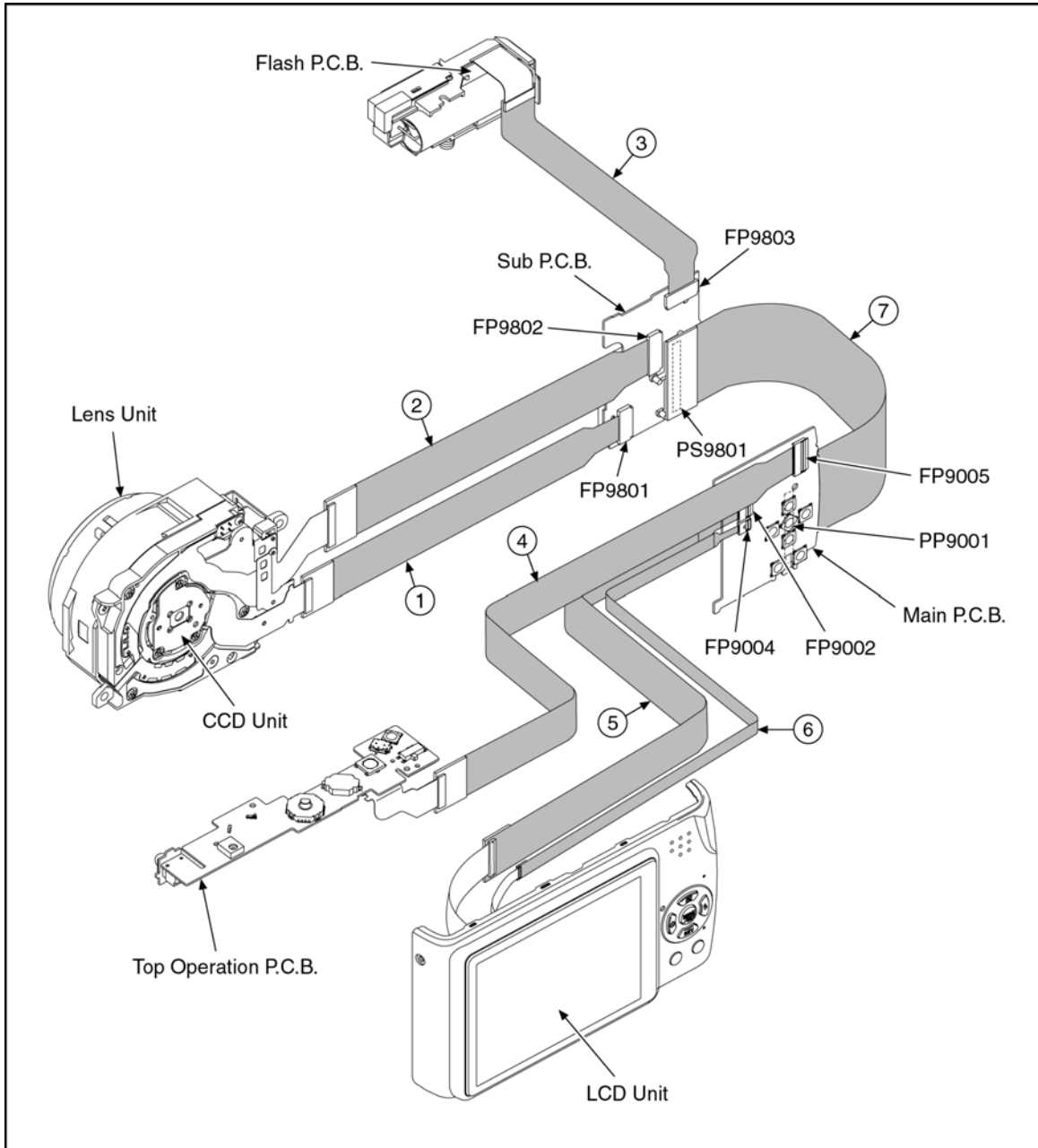

CAUTION-1. (When servicing FLASH TOP PCB)

1. Be sure to discharge the capacitor on FLASH PCB.
Refer to "HOW TO DISCHARGE THE CAPACITOR ON FLASH PCB".
The capacitor voltage is not lowered soon even if the AC Cord is unplugged or the battery is removed.
2. Be careful of the high voltage circuit on FLASH PCB.
3. DO NOT allow other parts to touch the high voltage circuit on FLASH PCB.

8 Disassembly and Assembly Instructions

8.1. Disassembly Flow Chart

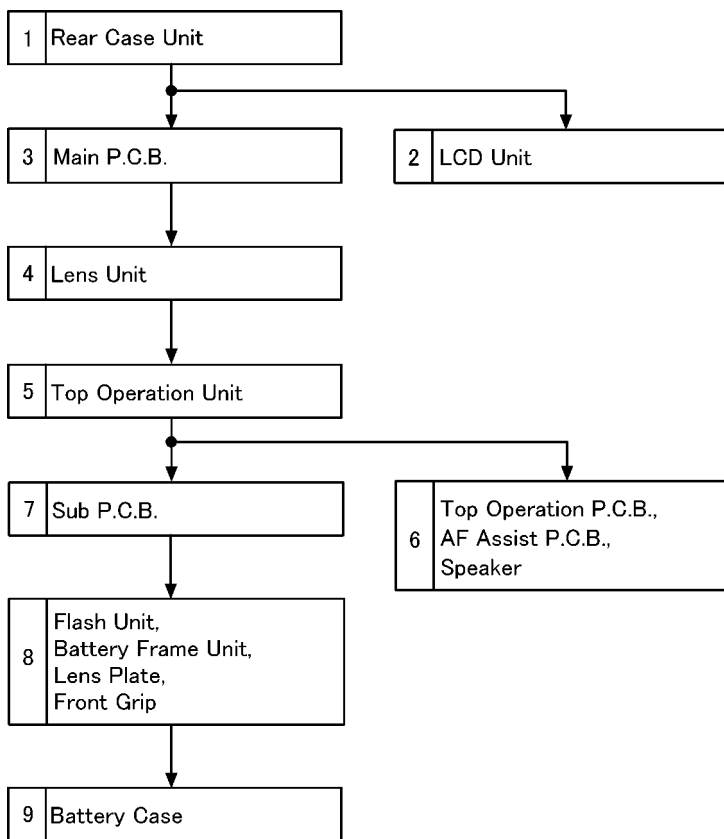

8.2. PCB Location

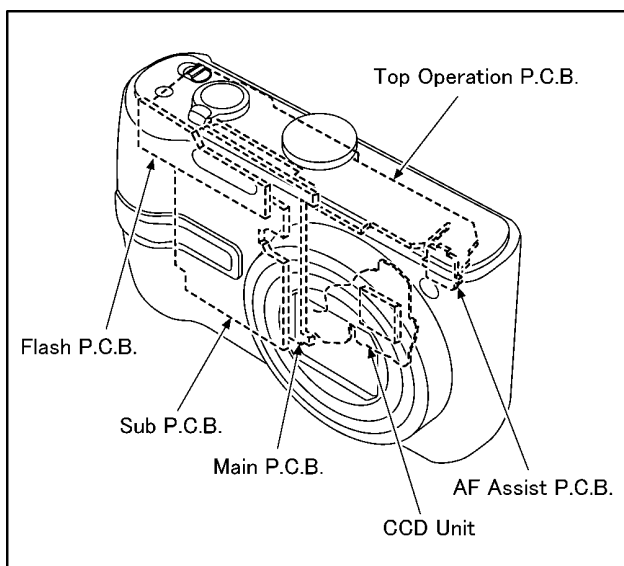

8.3. Disassembly Procedure

No.	Item	Fig	Removal
1	Rear Case Unit	Fig. D1 (DMC-TZ3) Fig. D1a (DMC-TZ2)	Card
			Battery
			3 Screws (A)
			1 Screw (B)
			1 Screw (C)
			FP9001(Flex) (DMC-TZ3)
			FP9003(Flex) (DMC-TZ3)
			FP9002(Flex) (DMC-TZ2)
			FP9004(Flex) (DMC-TZ2)
			Strap Holder
			Heat Radiation Sheet (DMC-TZ3)
			Lens Barrier Sheet (DMC-TZ2)
			Rear Case Unit
2	LCD Unit	Fig. D2 (DMC-TZ3) Fig. D2a (DMC-TZ2)	5 Locking tabs
			LCD Unit
3	Main P.C.B.	Fig. D3 (DMC-TZ3) Fig. D3a (DMC-TZ2)	PP9001(Connector)
			FP9005(Flex)
			Main P.C.B.
4	Lens Unit	Fig. D4	1 Screw (D)
			2 Screws (E)
			FP9801(Flex)
			FP9802(Flex)
			Lens Unit
5	Top Operation Unit	Fig. D5	Top Operation Unit
6	Top Operation P.C.B. AF Assist P.C.B. Speaker	Fig. D6	2 Locking tabs
			2 Screws (F)
			Top Operation P.C.B. AF Assist P.C.B. Speaker
		Fig. D7	NOTE: (When Installing)
7	Sub P.C.B.	Fig. D8	1 Screw (G)
			1 Screw (H)
			Earth Plate
			FP9803(Flex)
			1 Locking tab
			Sub P.C.B.
8	Flash Unit Battery Frame Unit Lens Plate Front Grip	Fig. D9	2 Screws (I)
			1 Screw (J)
			2 Screws (K)
			2 Screws (L)
		Fig. D10	2 Locking tabs
			Flash Unit
			Battery Frame Unit
			Lens Plate
			Front Grip
9	Battery Case	Fig. D11	3 Locking tabs
			Battery Case

8.3.1. Removal of the Rear Case Unit For DMC-TZ3

NOTE:

When servicing and reassembling, remove the card and battery from the unit.

- Card
- Battery
- Screw (A) × 3
- Screw (B) × 1
- Screw (C) × 1
- FP9001(Flex)
- FP9003(Flex)
- Strap Holder
- Heat Radiation Sheet

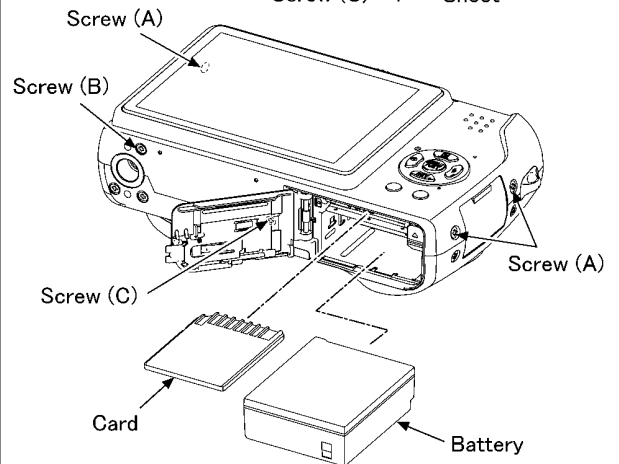

- When remove the heat radiation sheet, necessary removal the rear case unit.

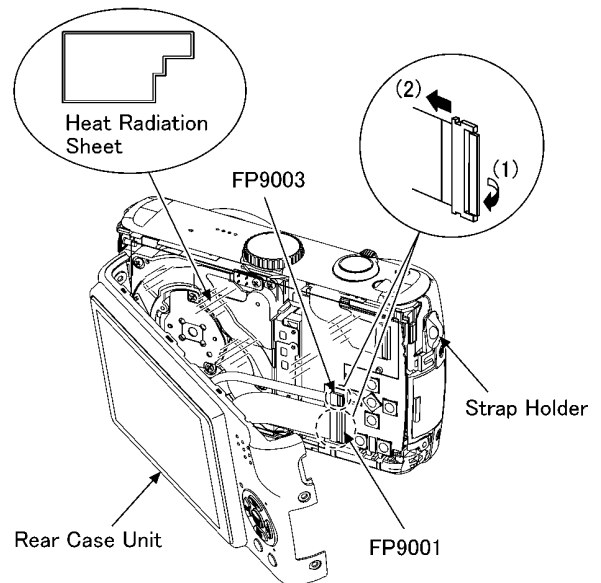

NOTE: (When Replacing)

1. When remove the flex, pull up the connector in the direction of arrow (1), and then remove the flex in the direction of arrow (2).
2. When remove the rear case unit, strap holder is remove together. Take care not to lose it.

Screw (A)	Screw (B)	Screw (C)
Ⓢ: SILVER Ⓐ Ⓚ: BLACK	Ⓢ: SILVER Ⓐ Ⓚ: BLACK	Ⓢ: SILVER Ⓐ Ⓚ: BLACK

Fig. D1

For DMC-TZ2

NOTE:

When servicing and reassembling, remove the card and battery from the unit.

- Card
- Battery
- Screw (A) × 3
- Screw (B) × 1
- Screw (C) × 1
- FP9002(Flex)
- FP9004(Flex)
- Strap Holder
- Lens Barrier Sheet

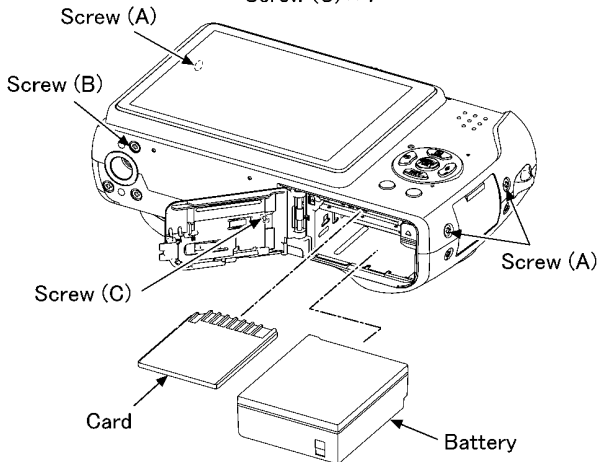

- When remove the lens barrier sheet, necessary removal the rear case unit.

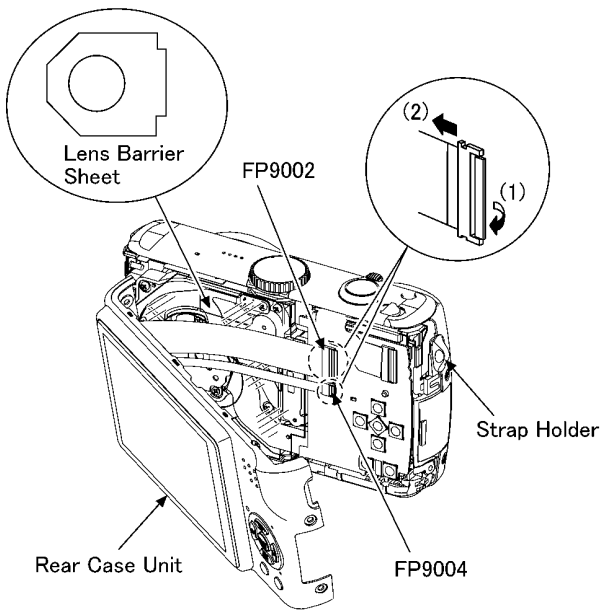

NOTE: (When Replacing)

1. When remove the flex, pull up the connector in the direction of arrow (1), and then remove the flex in the direction of arrow (2).
2. When remove the rear case unit, strap holder is remove together. Take care not to lose it.

Screw (A)	Screw (B)	Screw (C)
 5mm	 4mm	 2mm
Ⓢ: SILVER Ⓚ: BLACK	Ⓢ: SILVER Ⓚ: BLACK	Ⓢ: SILVER Ⓚ: BLACK

Fig. D1a

8.3.2. Removal of the LCD Unit

For DMC-TZ3

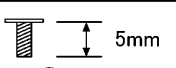
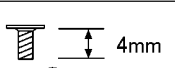
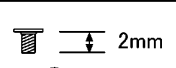
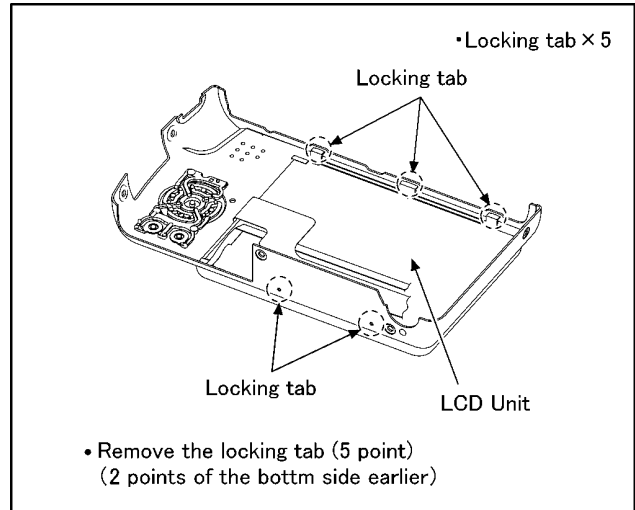

Fig. D2

For DMC-TZ2

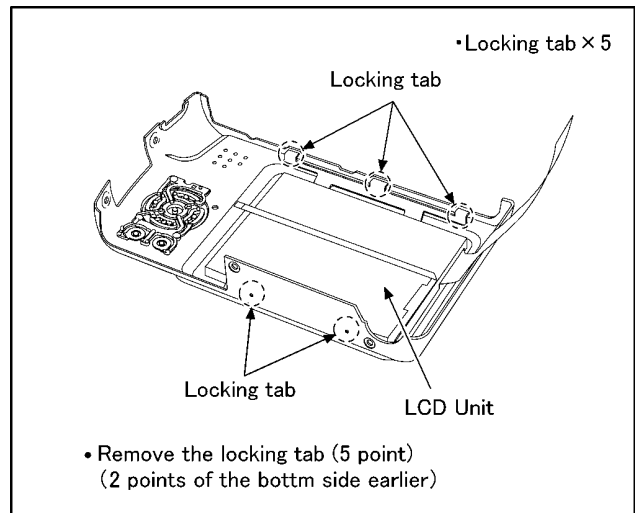

Fig. D2a

8.3.3. Removal of the Main P.C.B.

For DMC-TZ3

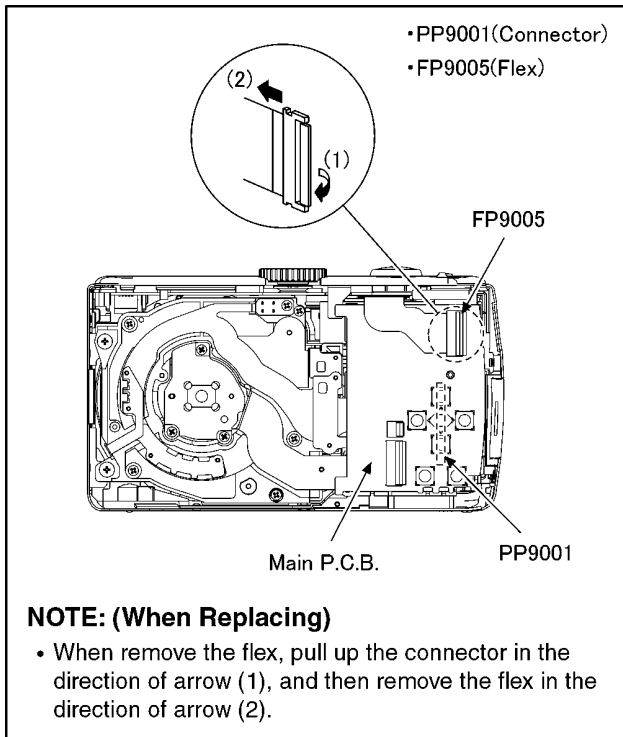

Fig. D3

For DMC-TZ2

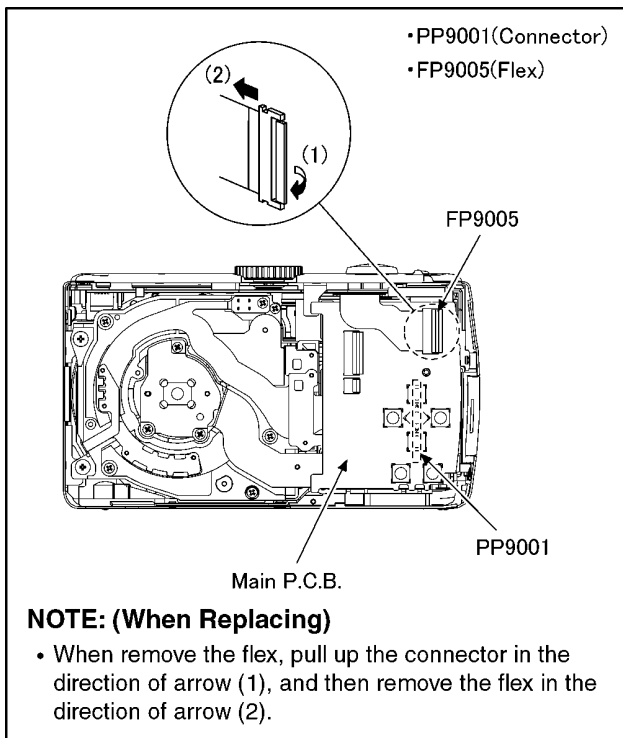

Fig. D3a

8.3.4. Removal of the Lens Unit

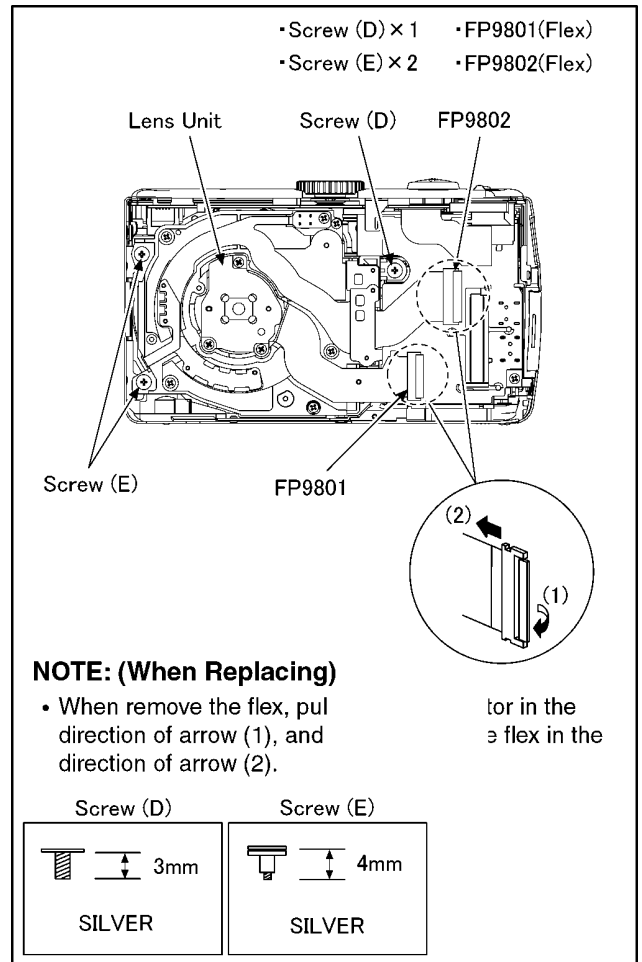

Fig. D4

8.3.5. Removal of the Top Operation Unit

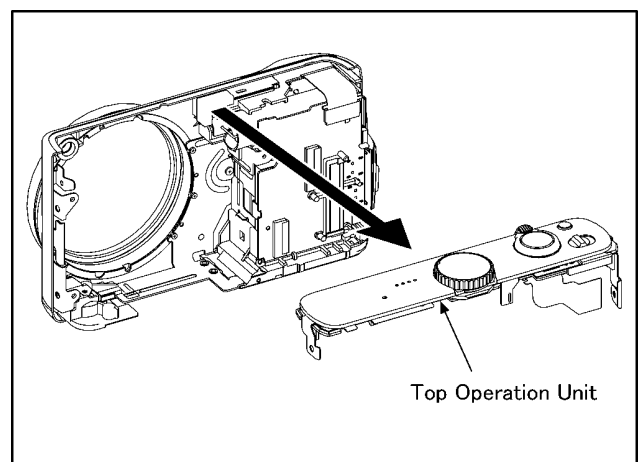

Fig. D5

8.3.6. Removal of the Top Operation P.C.B., AF Assist P.C.B. and Speaker

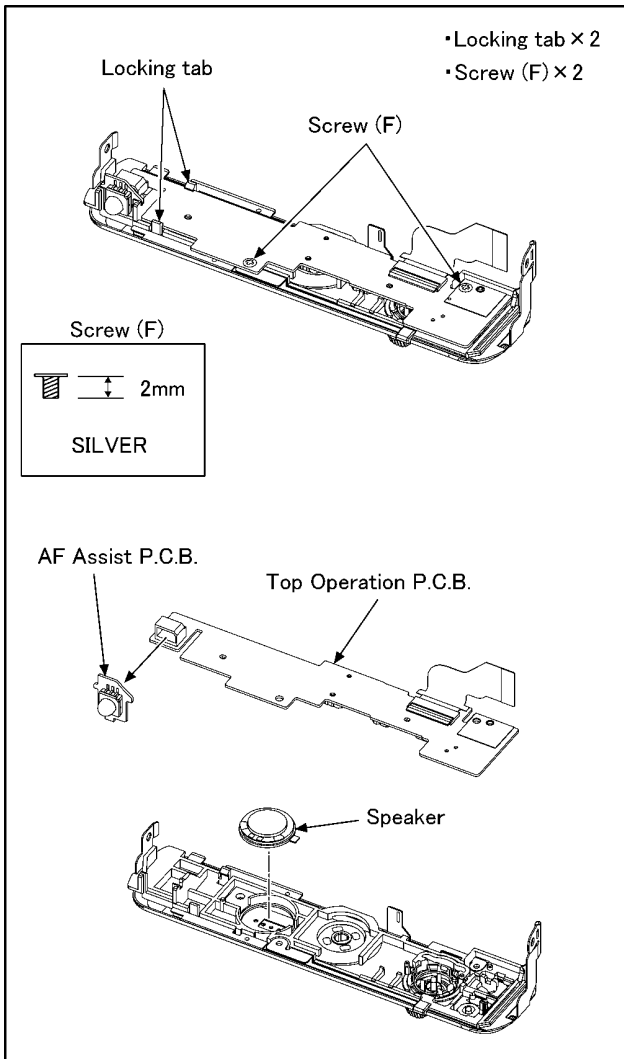

Fig. D6

NOTE: (When Installing)

Align the convex of power switch and groove of power knob.

Align the convex of mode dial switch and groove of mode dial. (Align the "D" cut part)

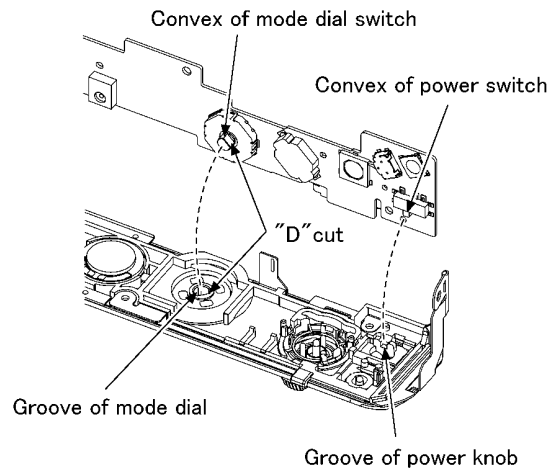
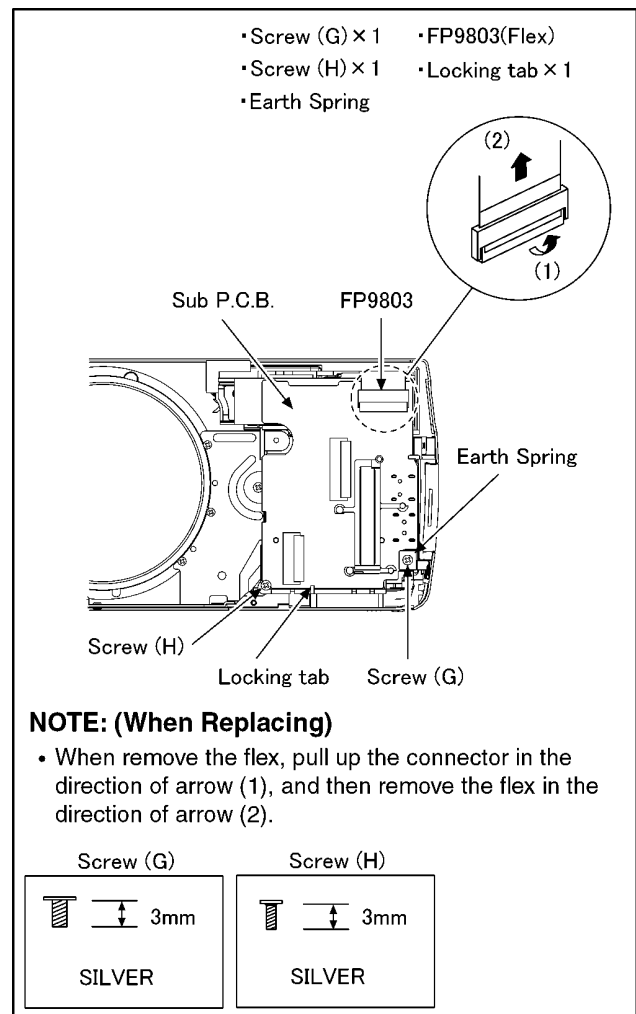

Fig. D7

8.3.7. Removal of the Sub P.C.B.



NOTE: (When Replacing)

- When remove the flex, pull up the connector in the direction of arrow (1), and then remove the flex in the direction of arrow (2).

Fig. D8

8.3.8. Removal of the Flash Unit, Battery Frame Unit, Lens Plate and Front Grip

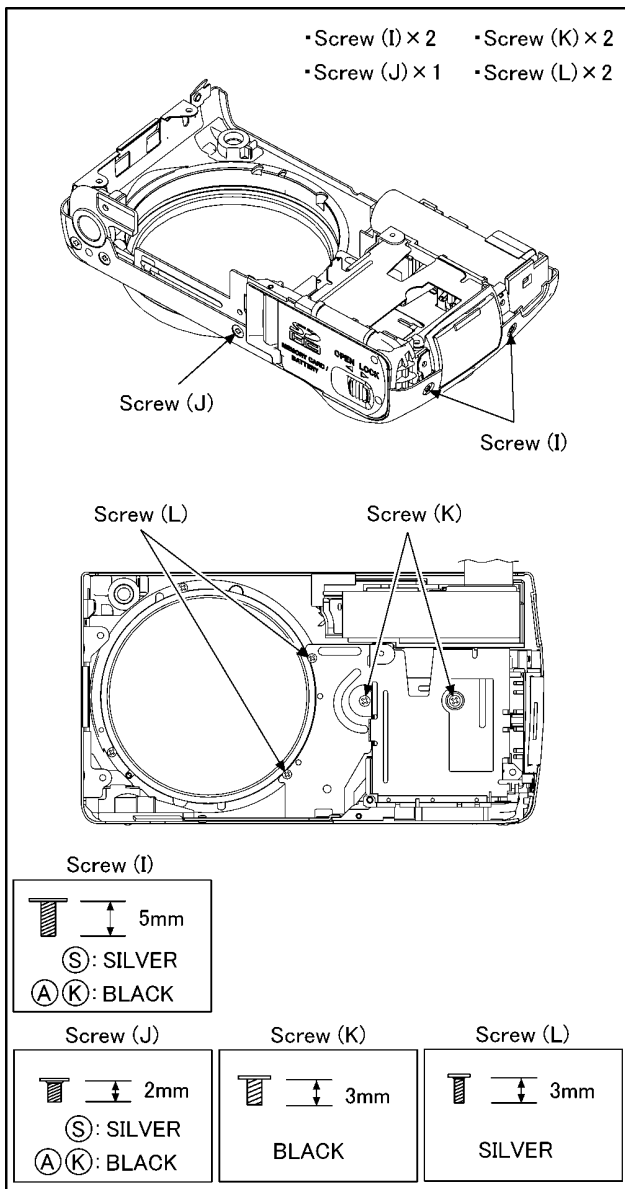
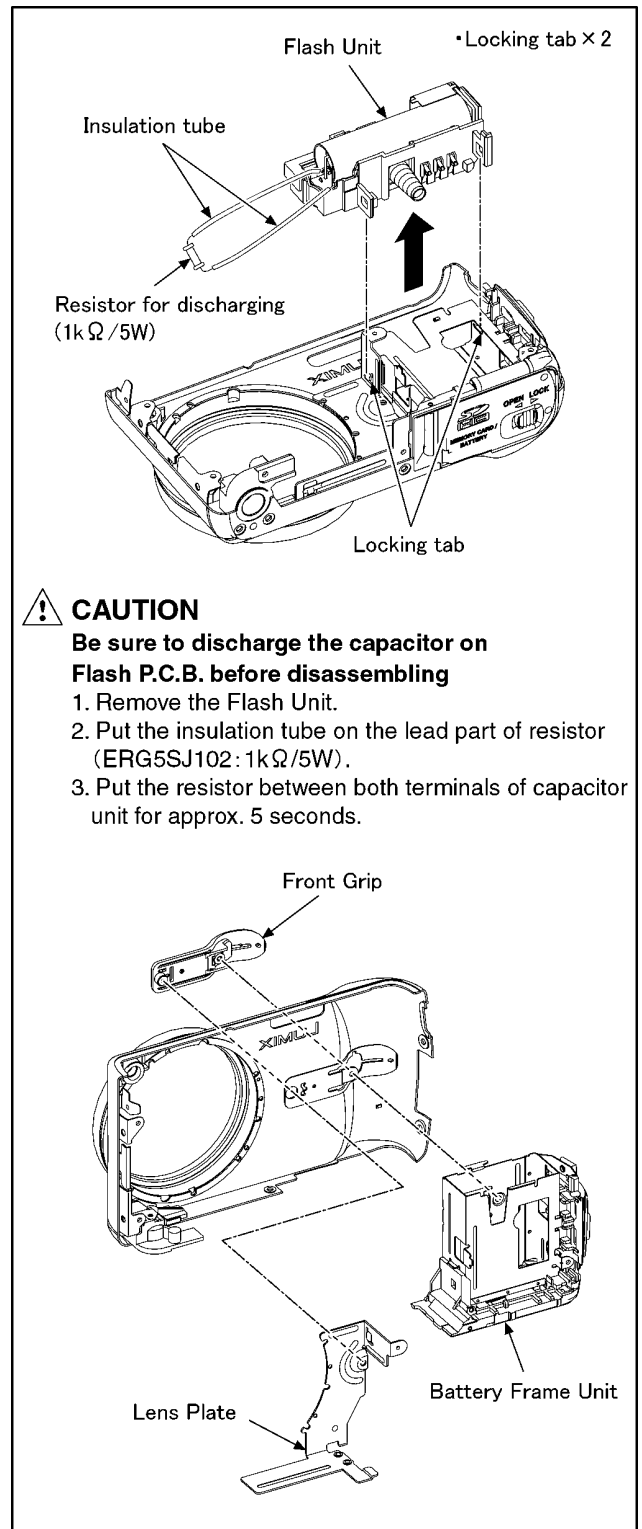

Fig. D9



CAUTION

Be sure to discharge the capacitor on Flash P.C.B. before disassembling

1. Remove the Flash Unit.
2. Put the insulation tube on the lead part of resistor (ERG5SJ102: 1kΩ/5W).
3. Put the resistor between both terminals of capacitor unit for approx. 5 seconds.

Fig. D10

8.3.9. Removal of the Battery Case

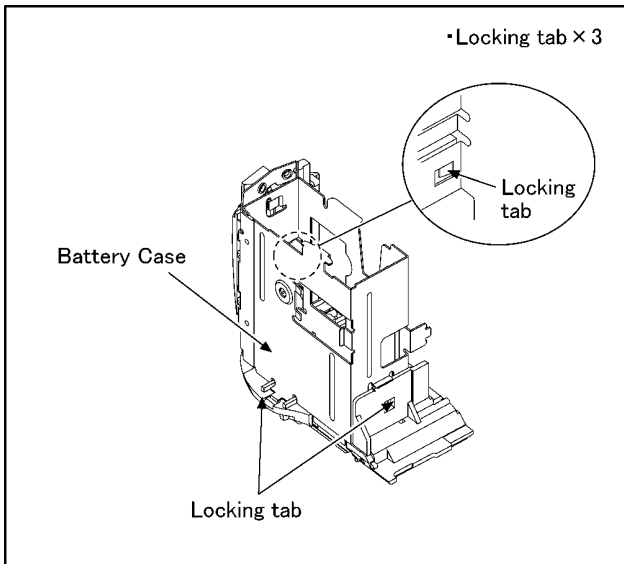

Fig. D11

NOTE: (When Assembling)

Be sure to confirm the following points when assembling.

- The Screw is tightened enough.
- Assembling conditions are fine. (No distortion, no illegal-space.)
- No dust and/or dirt on every Lens surfaces.
- LCD image is fine. (No dust and dirt on it, and no gradient images.)

8.4. Disassembly Procedure for the Lens

NOTE: When Disassembling and Assembling for the Lens

1. To minimize the possibility of the CCD being dirt, perform disassemble and/or assemble under the condition of the CCD is being mounted.
Disassembling procedures for the CCD unit, refer to item 8.6.
2. Take care that the dust and dirt are not entered into the lens.
In case of the dust is putted on the lens, blow off them by airbrush.
3. Do not touch the surface of lens.
4. Use lens cleaning KIT (BK)(VFK1900BK).
5. Apply the grease to the point where is shown to "Grease apply" in the figure.

8.4.1. Zoom Motor Unit and Master Frange Unit

1. Unsolder (16 points).
2. Remove the libs (4 points).
3. Unscrew the 6 screws (A).
4. Remove the zoom motor unit.
5. Remove the master flange unit.

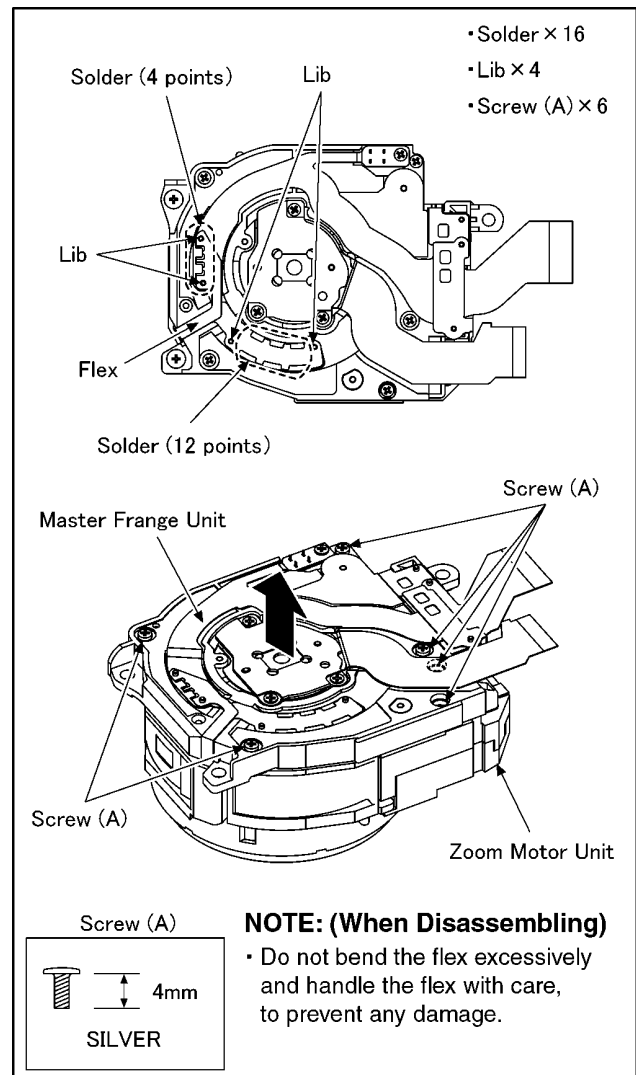

8.4.2. Removal of the Direct Frame, Both Side Cam, 1st Lens Frame/2nd Lens Frame/3rd Lens Frame, Penetration Cam and Drive Frame

- Push the penetration cam to the indicated by arrow from lens side, and then remove the unit of direct frame, both side cam, 1st lens frame/2nd lens frame/3rd lens frame, penetration cam and drive frame from the fixed frame unit.

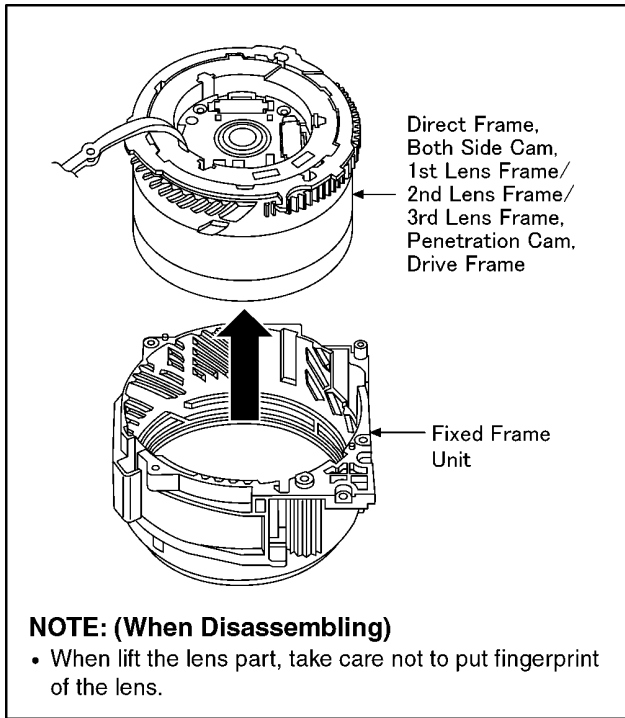

8.4.3. Removal of the Direct Frame, Both Side Cam and 1st Lens Frame/2nd Lens Frame/3rd Lens Frame

1. Turn the drive frame, and then Align the groove of drive frame and pin of 1st lens frame.

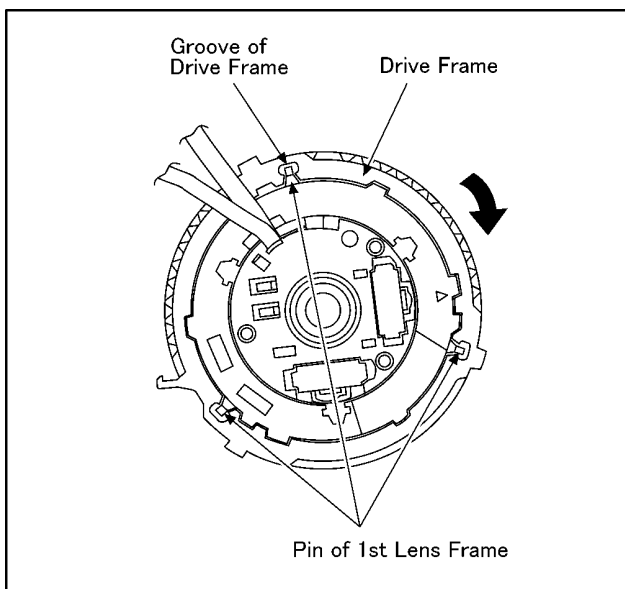

2. Push the 1st lens frame to the indicated by arrow from lens side, and then remove the unit of direct frame, both side cam and 1st lens frame/2nd lens frame/3rd lens frame from the penetration cam and drive frame.

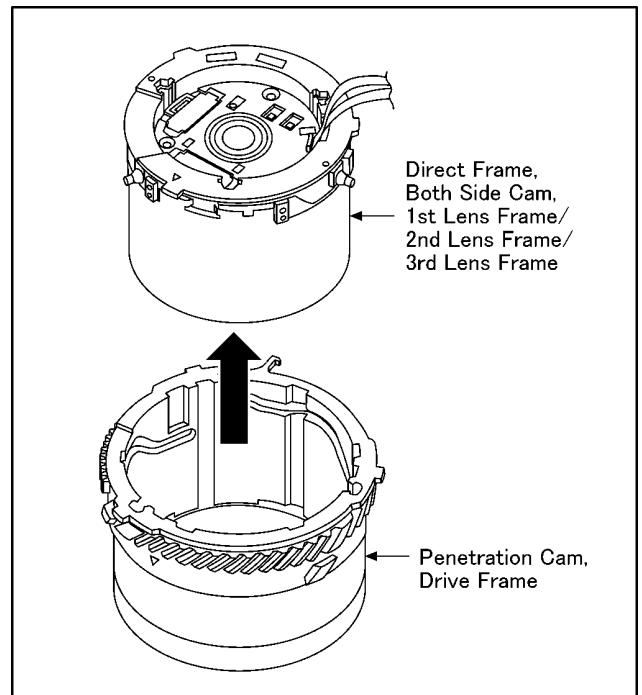

8.4.4. Removal of the Direct Frame, Both Side Cam and 2nd Lens Frame/3rd Lens Frame

- Turn to the indicated by arrow(1) while picking the pin, and then remove the unit of direct frame, both side cam and 2nd lens frame/3rd lens frame from the 1st lens frame.

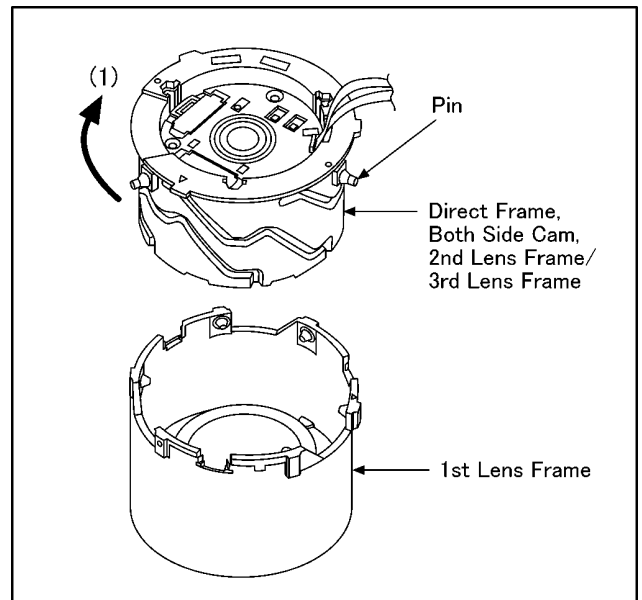

8.4.5. Removal of the 3rd Lens Frame and 2nd Lens Frame

1. Turn the direct frame, and then Align the groove of direct frame and groove of both side cam.
2. Remove the 3rd lens frame and 2nd lens frame from the direct frame, both side cam.

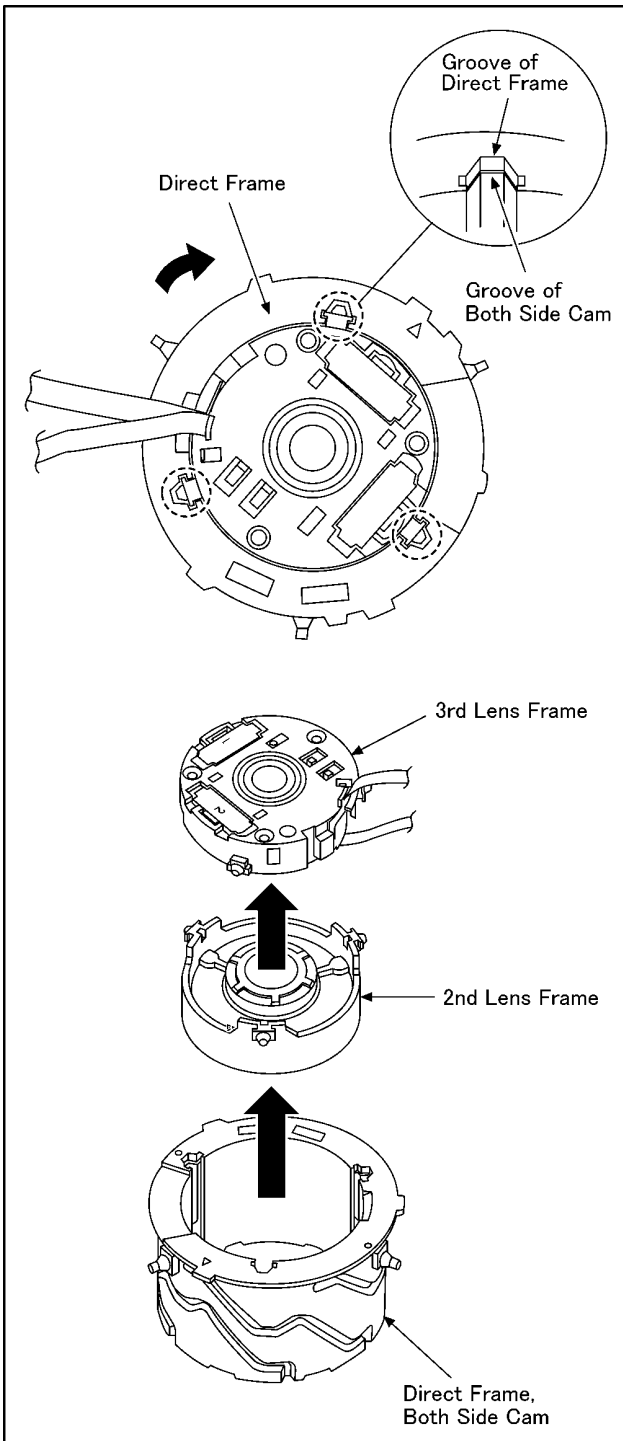

8.4.6. Removal of the Direct Frame

- Pull the direct frame to the indicated by arrow (1), and then turn to clockwise the direct frame in the indicated by arrow (2).

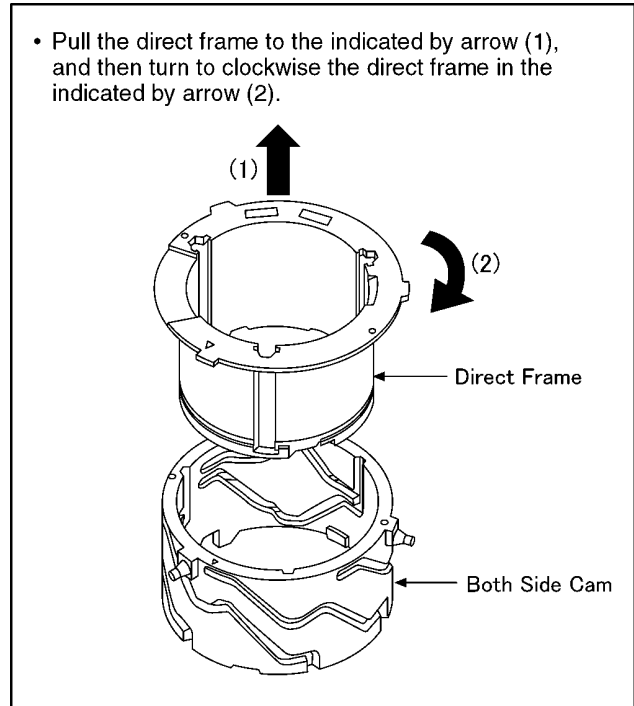

8.4.7. Removal of the Drive Frame

- Pull the drive frame to the indicated by arrow (1), and then turn to clockwise the drive frame in the indicated by arrow (2).

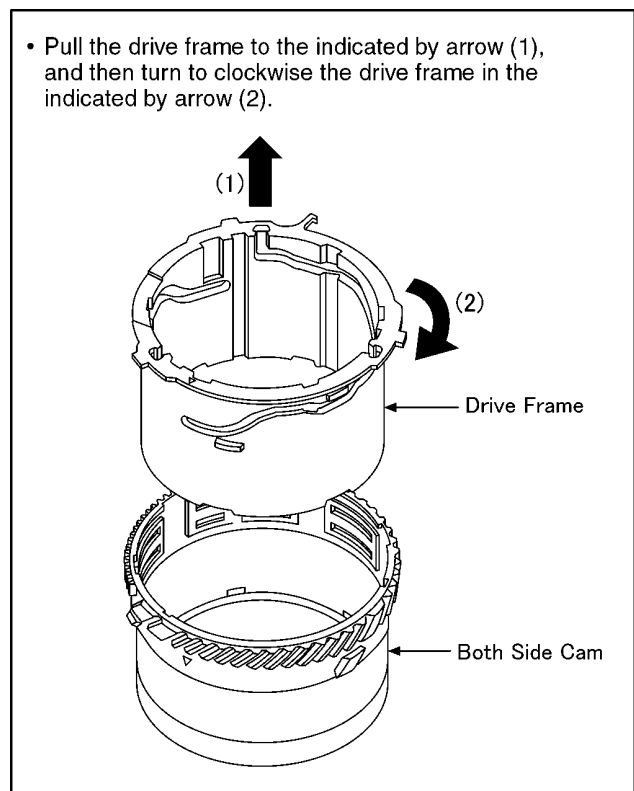

8.5. Assembly Procedure for the Lens

8.5.1. Phase alignment of the Penetration Cam and Drive Frame

- Align the Δ mark, and then install the drive frame to penetration cam.

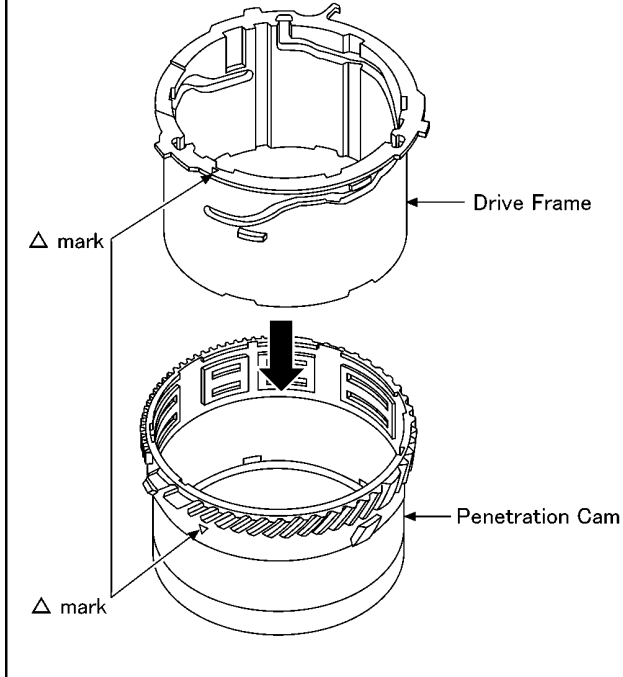

- Turn the Drive Frame in the direction of an arrow (about 5mm : 0.2 in.), and then align the phase so that three groove places to be aligned.

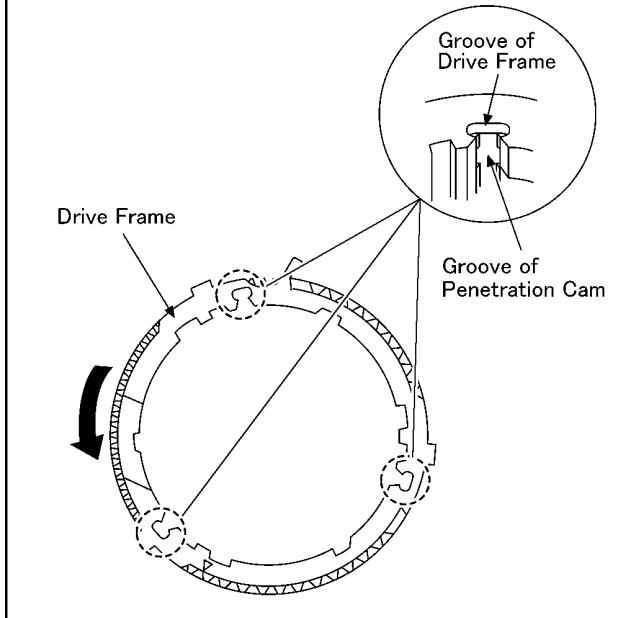

8.5.2. Phase alignment of the Direct Frame and Both Side Cam

- Align the Δ mark, and then install the direct frame to both side cam.

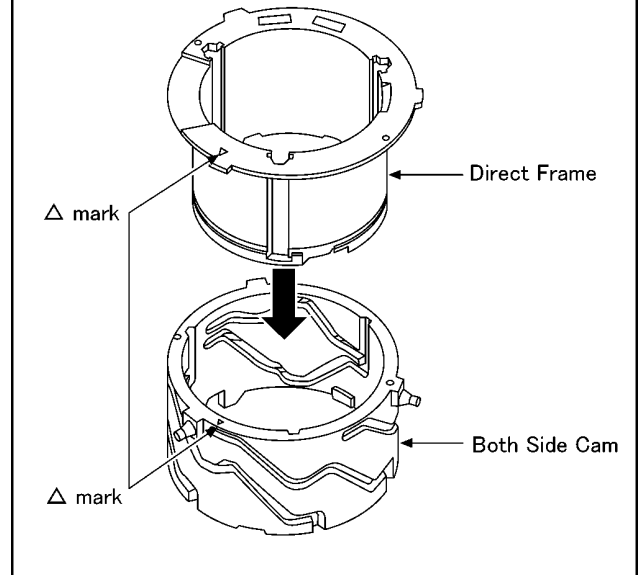

- Align the phase direct frame and three groove places to be aligned.

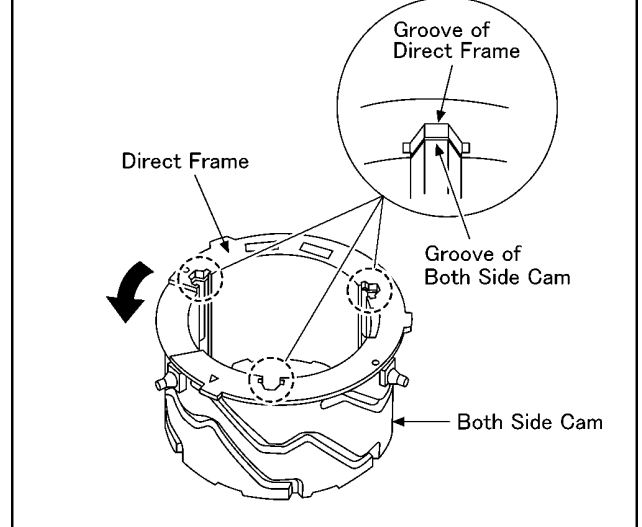

8.5.3. Assembly for the 2nd Lens Frame and 3rd Lens Frame

- Align the Δ mark, and then install the 2nd lens frame to direct frame, both side cam.

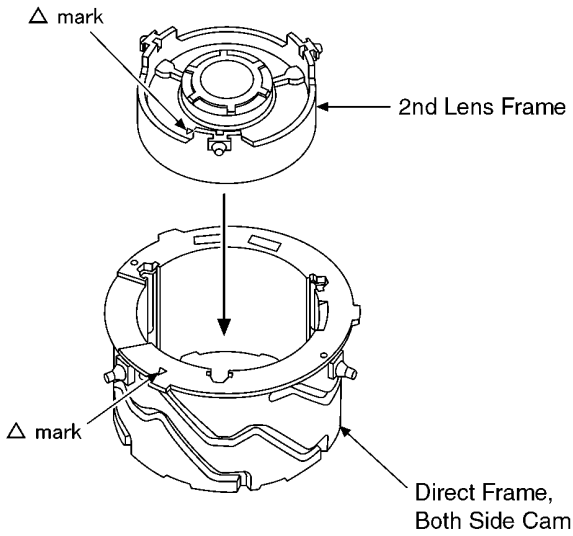

- Δ mark Make the OIS York of 3rd lens frame and Δ mark position relations of a figure, and then insert 3rd lens frame to direct frame, both side cam, 2nd lens frame.

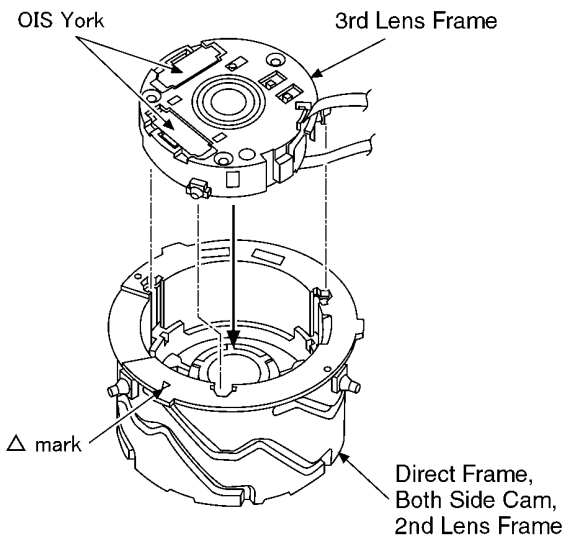

8.5.4. Assembly for the Direct Frame, Both Side Cam and 2nd Lens Frame/3rd Lens Frame

- Aim for a Δ mark of 3rd lens frame and a cam pin of figure below, and then insert direct frame, both side cam, 2nd lens frame, 3rd lens frame to 1st lens frame.

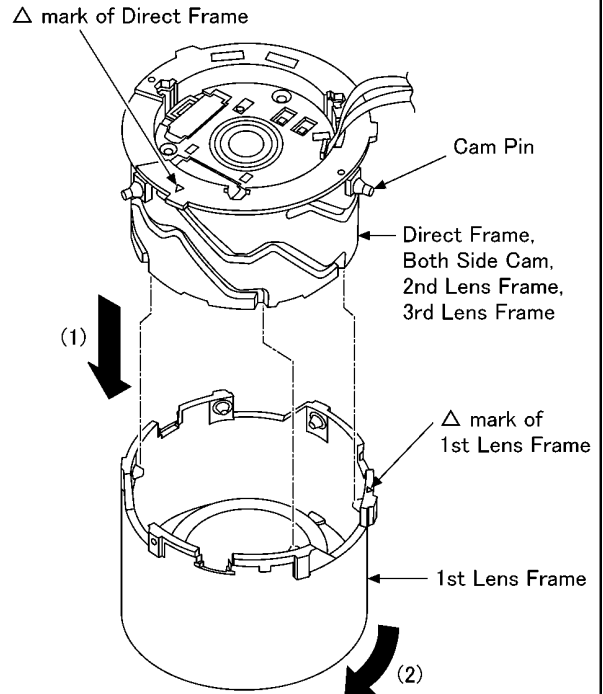

8.5.5. Assembly for the Direct Frame, Both Side Cam and 1st Lens Frame/ 2nd Lens Frame/3rd Lens Frame

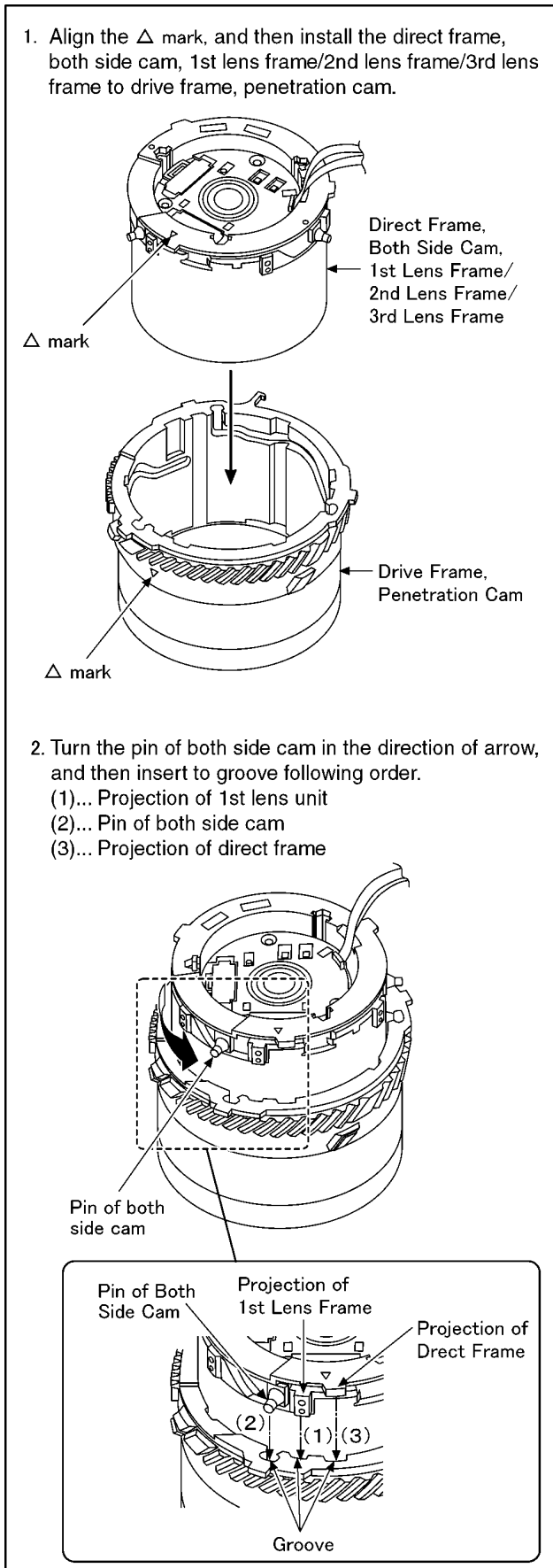

8.5.6. Assembly for the Direct Frame, Both Side Cam, 1st Lens Frame/ 2nd Lens Frame/3rd Lens Frame, Penetration Cam and Drive Frame

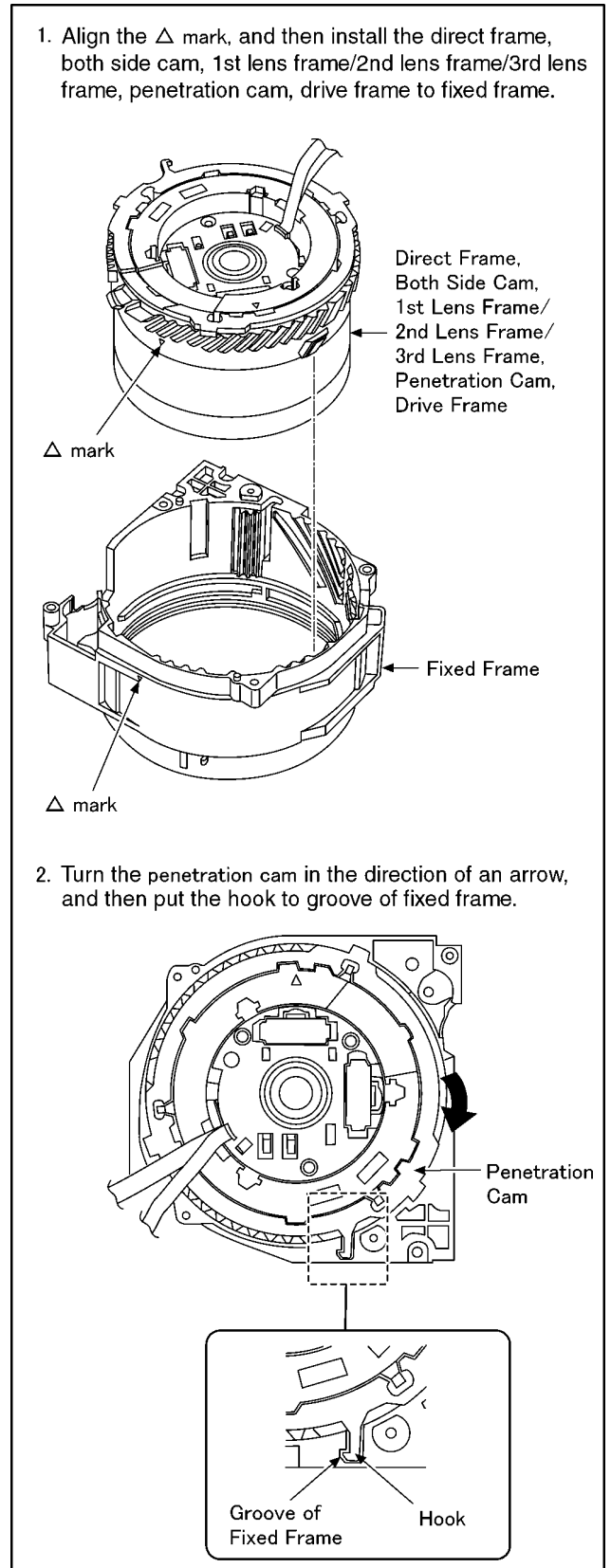

8.5.7. Assembly for the Zoom Motor Unit and Master Flange Unit

• Screw (A) × 6

NOTE: (When Installing)

- Refer to "THE APPLYMENT OF GREASE METHOD" when installing the master flange unit.
- Take care not to damage the flex.

- Insert the projection of master flange unit to hole of flex, and then insert to flex inserting part.

Maseter Flange Unit

Projection

Hole of Flex

Flex Inserting Part

Screw (A)

Maseter Flange Unit

Screw (A)

Zoom Motor Unit

- Align the lib of fixed frame unit and hole of zoom motor unit, and then install them.

Fixed Frame Unit

Lib

Zoom Motor Unit

Screw (A)

4mm

SILVER

• Lib × 4
• Solder × 16

Solder (4 points)

Lib

Lib

Flex

Solder (12 points)

8.6. Removal of the CCD Unit

To prevent the CCD unit from catching the dust and dirt, do not remove the CCD unit except for replacing.

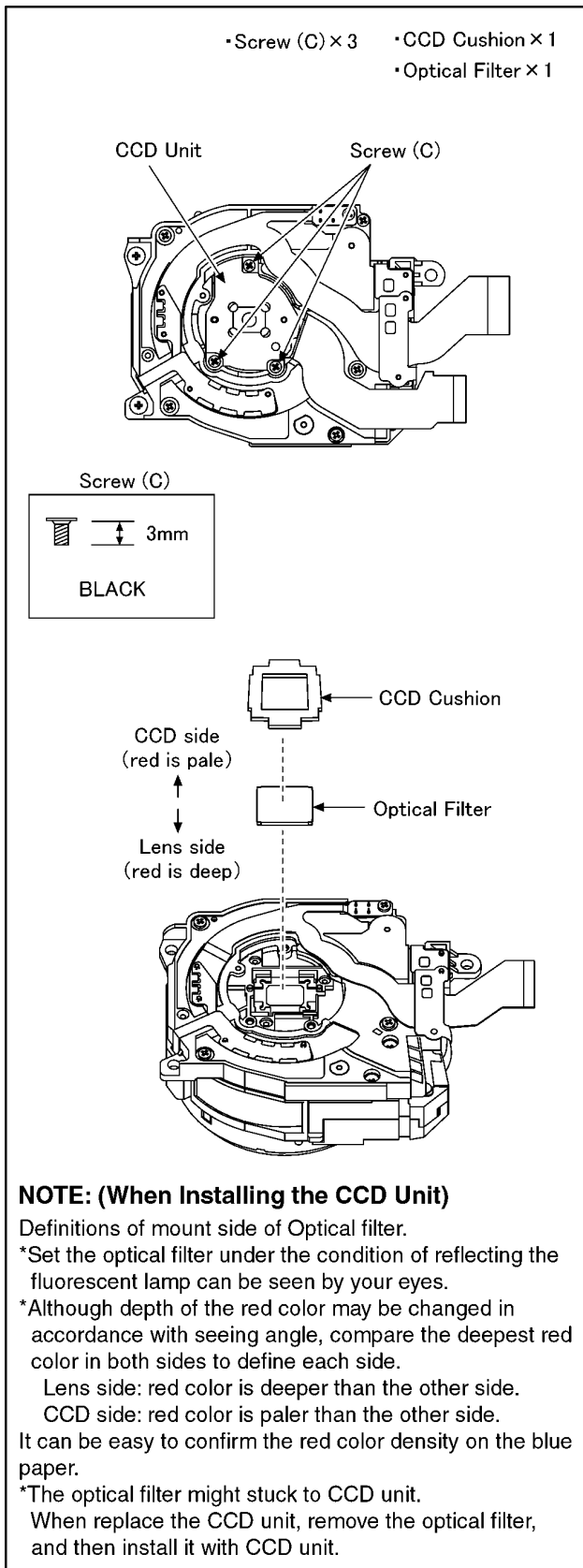

8.7. Removal of the Zoom Motor Unit

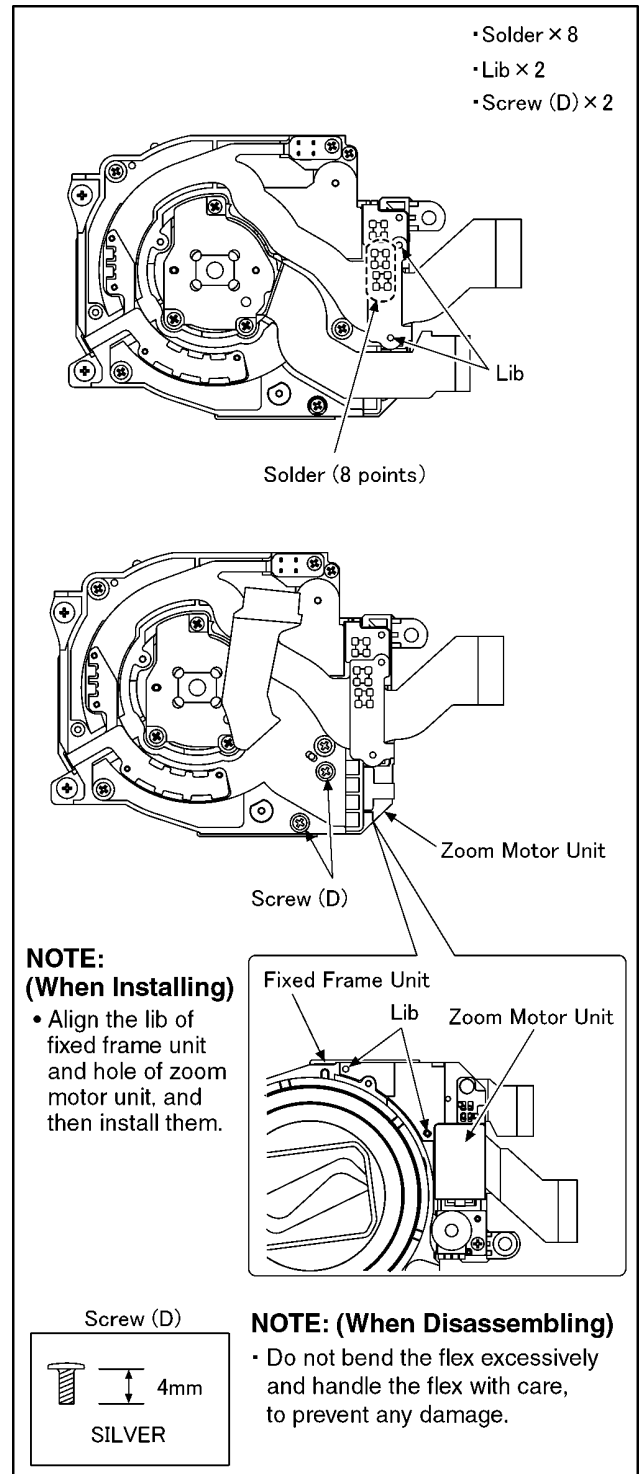

8.8. Removal of the Focus Motor Unit

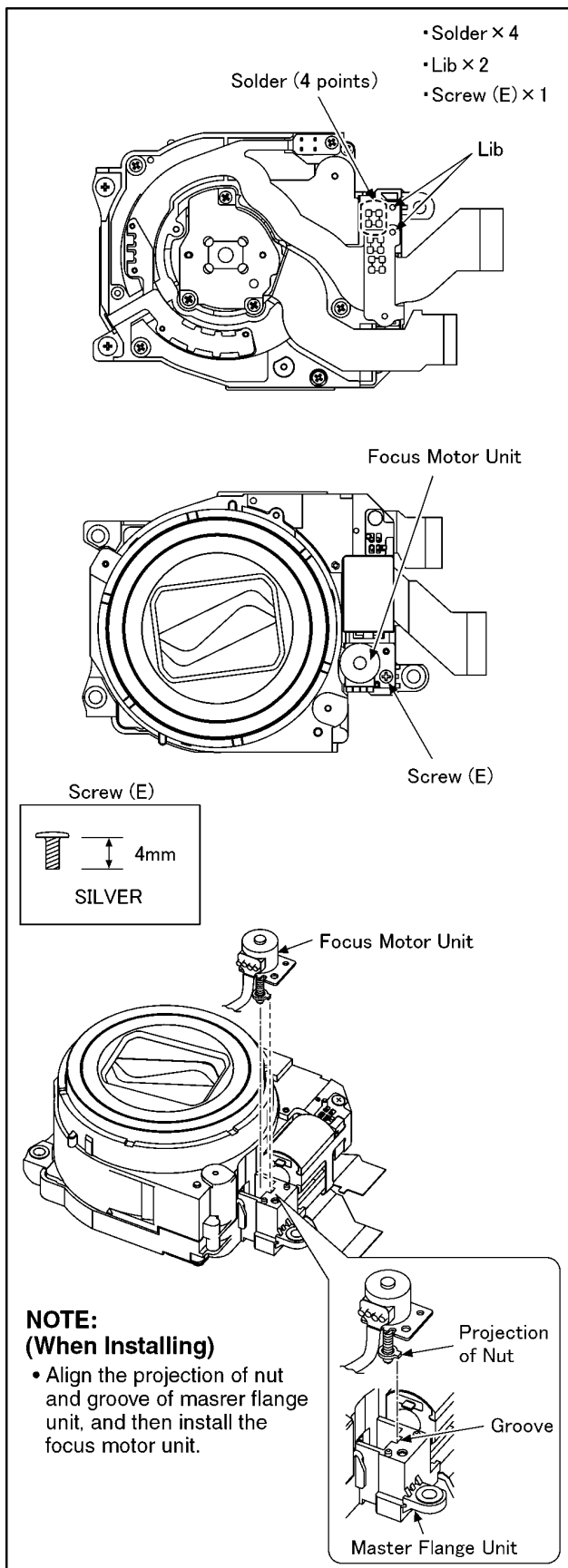

8.9. The Applyment of Grease Method

The grease apply point of lens unit are as follows.
Apply grease additionally in the specified position if necessary.
When the grease is applied, use a toothpick and apply thinly.

- Focus motor nut moving part
 - Grease: VFK1850 (Furoyl type)
 - Amount of apply: 3 - 5 mg
- 4th lens frame positioning pole, guide pole
 - Grease: VFK1829
 - Amount of apply: 0.15 - 0.35 mg

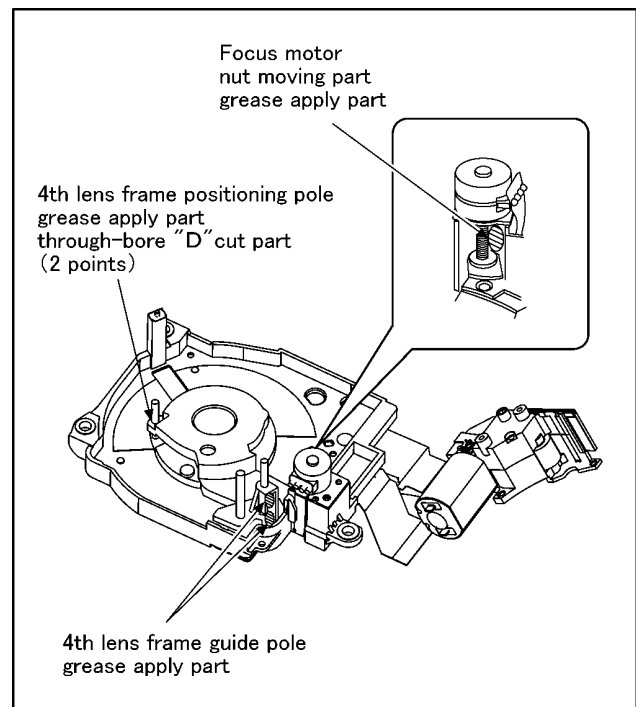

9 Measurements and Adjustments

9.1. Matrix Chart for Replaced Part and Necessary Adjustment

The relation between Replaced part and Necessary Adjustment is shown in the following table.

When concerned part is replaced, be sure to achieve the necessary adjustment(s).

As for Adjustment condition/procedure, consult the "Adjustment Manual" which is available in Adjustment software.

The Adjustment software is available at "TSN Website", therefore, access to "TSN Website" at "Support Information from NWBG/VDBG-PAVC".

NOTE:

After adjustments have been terminated, make sure to achieve "INITIAL SETTINGS".

Adjustment Item		Replaced Part				
		Main P.C.B.	VENUS (IC6001)	Flash-ROM (IC6002)	Lens Part (Excluding CCD)	CCD Unit
Camera Section	OIS hall element adjustment (OIS)	○	○	○	○	
	Back focus adjustment (BF)	○	○	○	○	
	Shutter adjustment (SHT)	○	○	○	○	○
	ISO sensitivity adjustment (ISO)	○	○	○	○	○
	AWB adjustment High brightness coloration inspection (WBL)	○	○	○	○	○
	CCD white scratch compensation (WKI)	○	○	○		○

NOTE:

*There is no LCD adjustment in this model.

*There is no CCD Black scratch compensation adjustment (BKI) in this model.

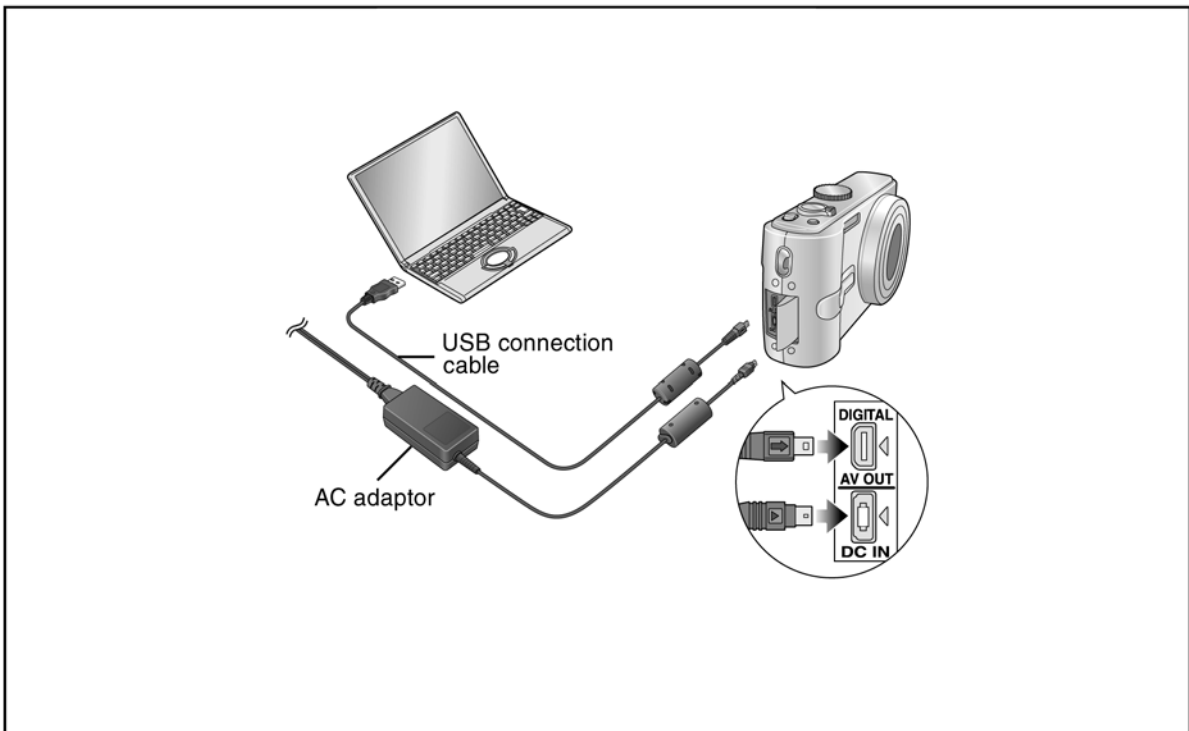

10 Maintenance

10.1. Cleaning Lens and LCD Panel

Do not touch the surface of lens and LCD Panel with your hand.

When cleaning the lens, use air-Blower to blow off the dust.

When cleaning the LCD Panel, dampen the lens cleaning paper with lens cleaner, and the gently wipe the their surface.

Note:

The Lens Cleaning KIT ; VFK1900BK (Only supplied as 10 set/Box) is available as Service Aid.

Service Manual

Diagrams and Replacement Parts List

Digital Camera

Model No.

DMC-TZ2P	DMC-TZ2GD	DMC-TZ3EF
DMC-TZ2PC	DMC-TZ2GK	DMC-TZ3EG
DMC-TZ2PL	DMC-TZ2GN	DMC-TZ3EGM
DMC-TZ2EB	DMC-TZ2GT	DMC-TZ3GC
DMC-TZ2EE	DMC-TZ3P	DMC-TZ3GD
DMC-TZ2EF	DMC-TZ3PC	DMC-TZ3GK
DMC-TZ2EG	DMC-TZ3PL	DMC-TZ3GN
DMC-TZ2EGM	DMC-TZ3EB	DMC-TZ3GT
DMC-TZ2GC	DMC-TZ3EE	DMC-TZ3SG

Vol. 1

Colour

(S).....Silver Type

(K).....Black Type (except DMC-TZ2PL/GD/GT)

(A).....Blue Type (only DMC-TZ3P/PC/EB/EE/EF/EG/EGM/GC/SG)

Table of contents

S1. About Indication of The Schematic Diagram.....	S-1	S4.4. CCD Flex P.C.B. (DMC-TZ2)	S-11
S1.1. Important Safety Notice.....	S-1	S4.5. CCD Flex P.C.B. (DMC-TZ3)	S-12
S2. Block Diagram.....	S-2	S4.6. Lens Flex P.C.B.....	S-13
S2.1. Overall Block Diagram	S-2	S5. Replacement Parts List.....	S-15
S3. Schematic Diagram.....	S-3	S6. Exploded View	S-20
S3.1. Interconnection Diagram	S-3	S6.1. Frame and Casing Section.....	S-20
S3.2. Flash Schematic Diagram	S-4	S6.2. Packing Parts and Accessories Section (1)	S-21
S3.3. Top Operation Schematic Diagram	S-5	S6.3. Packing Parts and Accessories Section (2)	S-22
S3.4. AF Assist Schematic Diagram	S-5		
S3.5. CCD Flex Schematic Diagram (DMC-TZ2).....	S-6		
S3.6. CCD Flex Schematic Diagram (DMC-TZ3).....	S-7		
S3.7. Lens Flex Schematic Diagram	S-8		
S4. Print Circuit Board.....	S-9		
S4.1. Flash P.C.B.	S-9		
S4.2. Top Operation P.C.B.....	S-10		
S4.3. AF Assist P.C.B.	S-10		

S1. About Indication of The Schematic Diagram

S1.1. Important Safety Notice

COMPONENTS IDENTIFIED WITH THE MARK \triangle HAVE THE SPECIAL CHARACTERISTICS FOR SAFETY. WHEN REPLACING ANY OF THESE COMPONENTS USE ONLY THE SAME TYPE.

1. Although reference number of the parts is indicated on the P.C.B. drawing and/or schematic diagrams, it is NOT mounted on the P.C.B. when it is displayed with "\$" mark.
2. It is only the "Test Round" and no terminal (Pin) is available on the P.C.B. when the TP (Test Point) indicated as "●" mark.
3. The voltage being indicated on the schematic diagram is measured in "Standard-Playback" mode when there is no specify mode is mentioned.
4. Although the voltage and waveform available on here is measured with standard frame, it may be differ from actual measurement due to modification of circuit and so on.
5. The voltage being indicated here may be include observational-error (deviation) due to internal-resistance and/or reactance of equipment. Therefore, handle the value indicated on here as reference.
6. Use the parts number indicated on the Replacement Parts List .
7. Indication on Schematic diagrams:

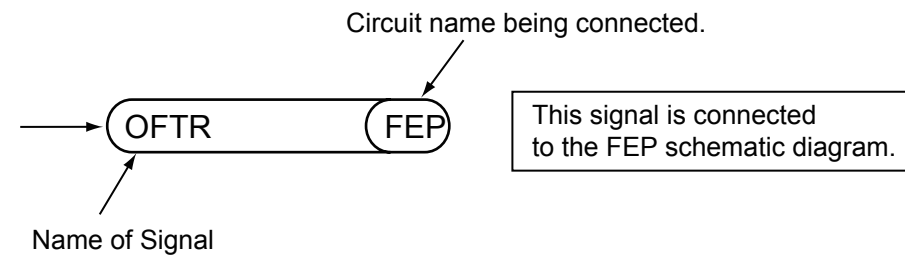

S2. Block Diagram

S2.1. Overall Block Diagram

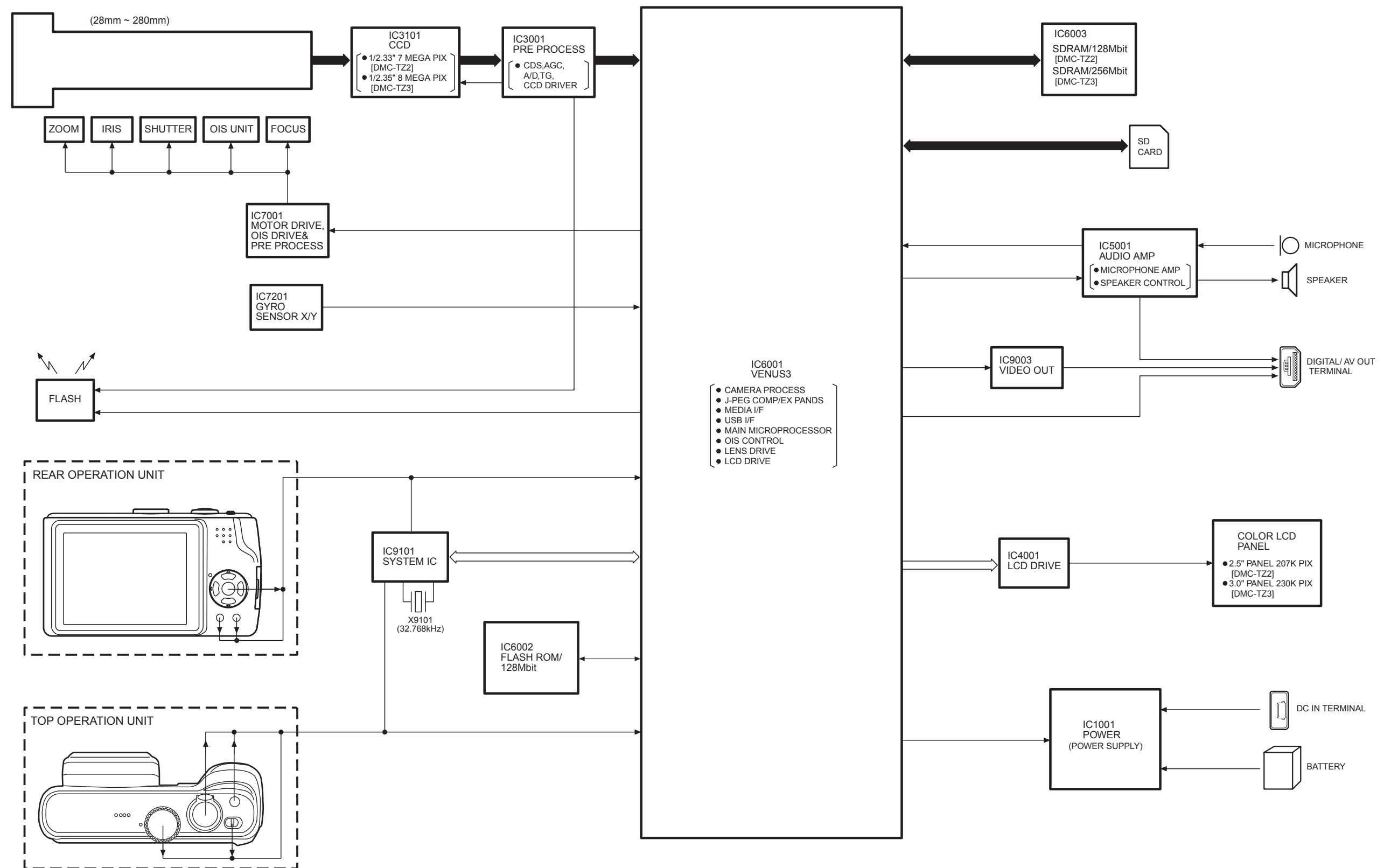

S3. Schematic Diagram

S3.1. Interconnection Diagram

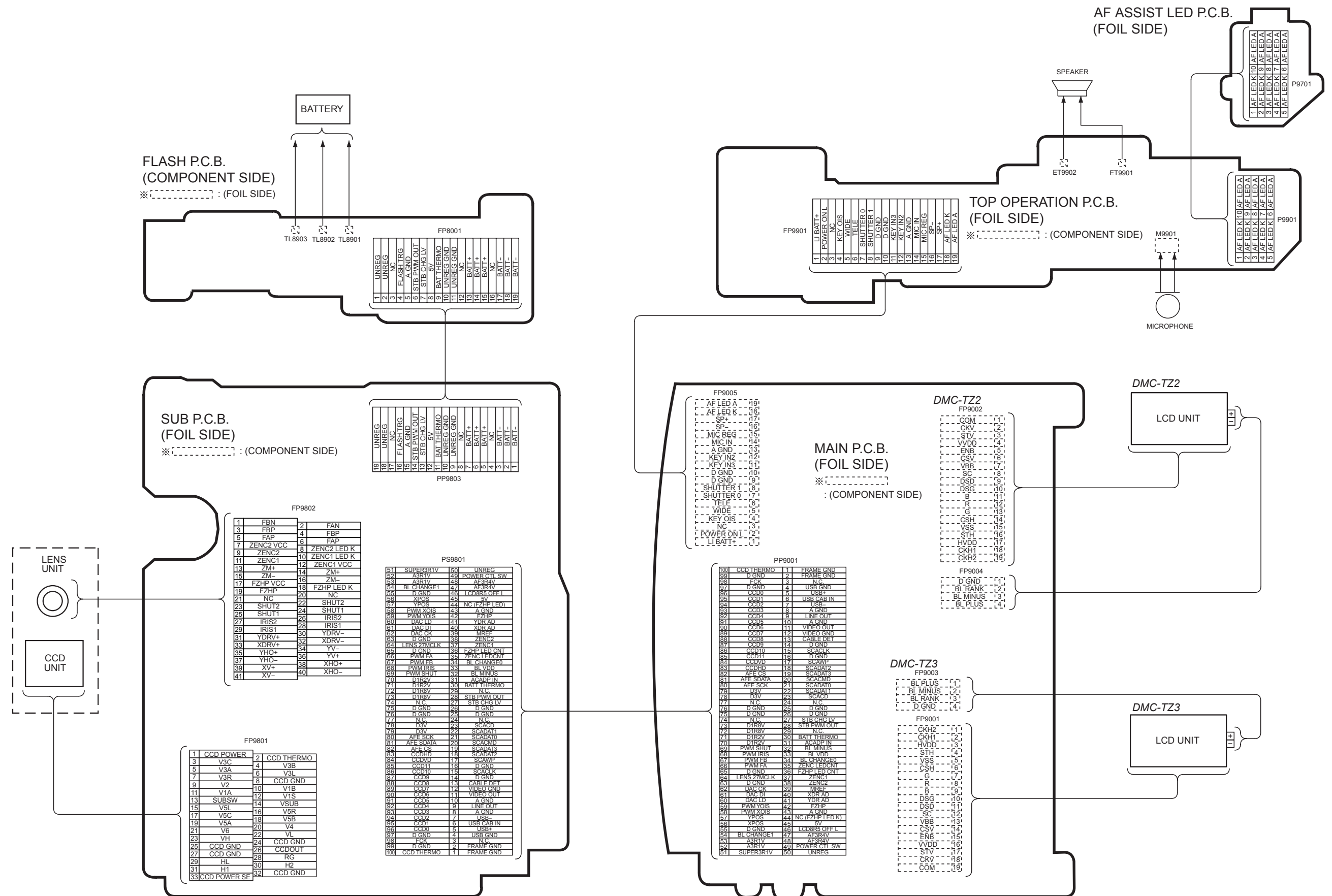

S3.2. Flash Schematic Diagram

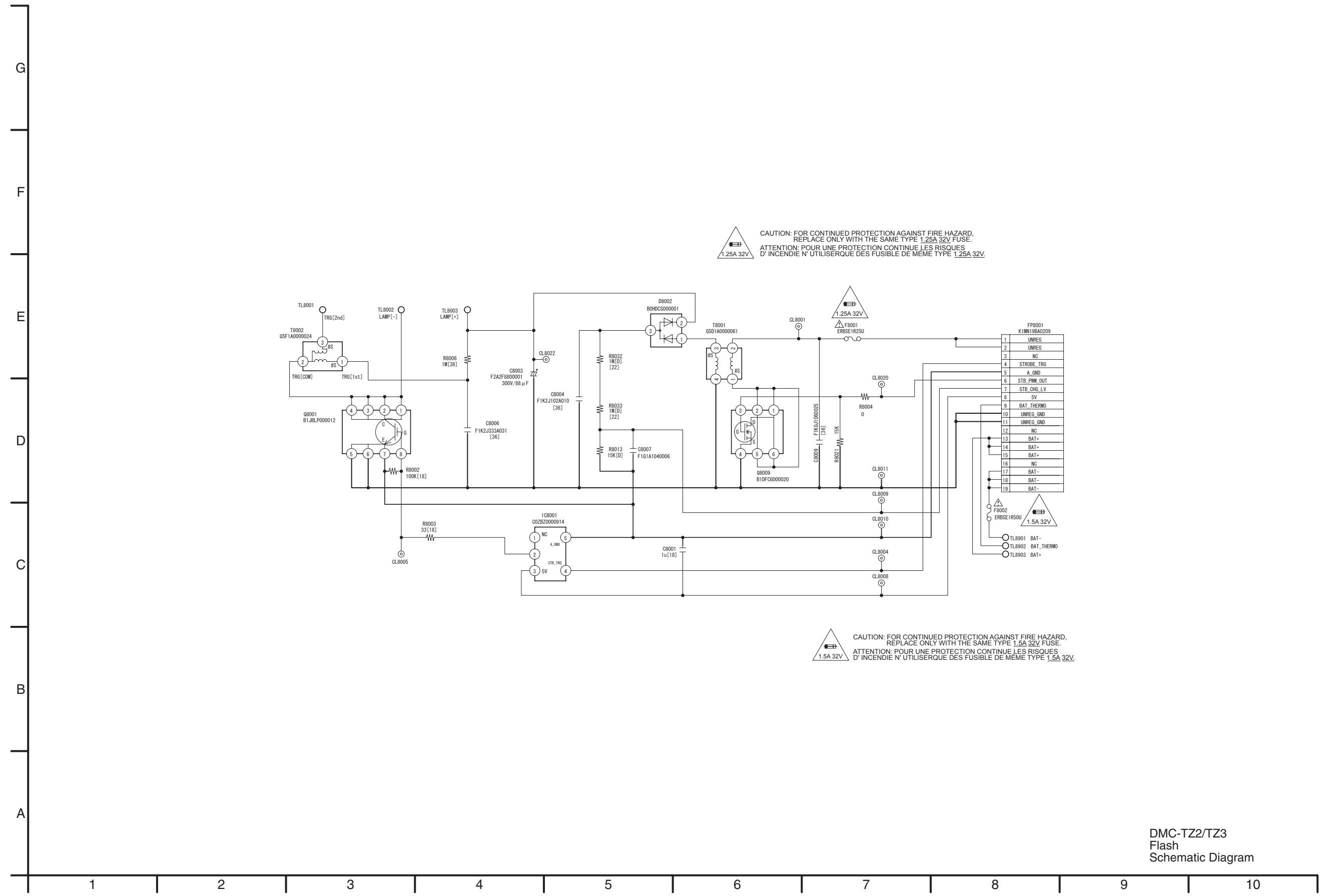

CAUTION: FOR CONTINUED PROTECTION AGAINST FIRE HAZARD, REPLACE ONLY WITH THE SAME TYPE 1.25A 32V FUSE.
 ATTENTION: POUR UNE PROTECTION CONTINUE LES RISQUES D'INCENDIE N'UTILISER QUE DES FUSIBLE DE MEME TYPE 1.25A 32V.

CAUTION: FOR CONTINUED PROTECTION AGAINST FIRE HAZARD, REPLACE ONLY WITH THE SAME TYPE 1.5A 32V FUSE.
 ATTENTION: POUR UNE PROTECTION CONTINUE LES RISQUES D'INCENDIE N'UTILISER QUE DES FUSIBLE DE MEME TYPE 1.5A 32V.

DMC-TZ2/TZ3
Flash
Schematic Diagram

S3.3. Top Operation Schematic Diagram / S3.4. AF Assist Schematic Diagram

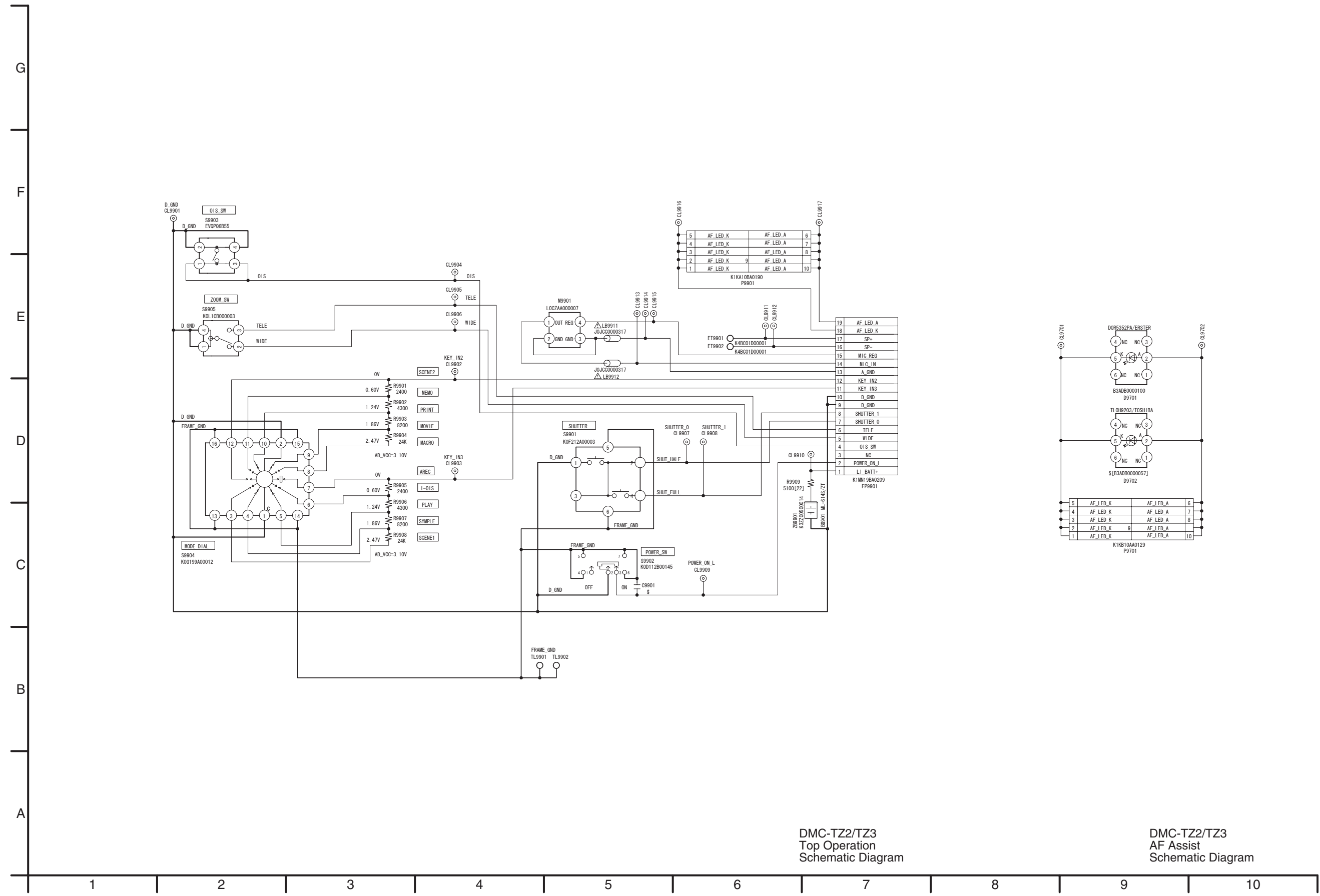

DMC-TZ2/TZ3
Top Operation
Schematic Diagram

DMC-TZ2/TZ3
AF Assist
Schematic Diagram

S3.5. CCD Flex Schematic Diagram (DMC-TZ2)

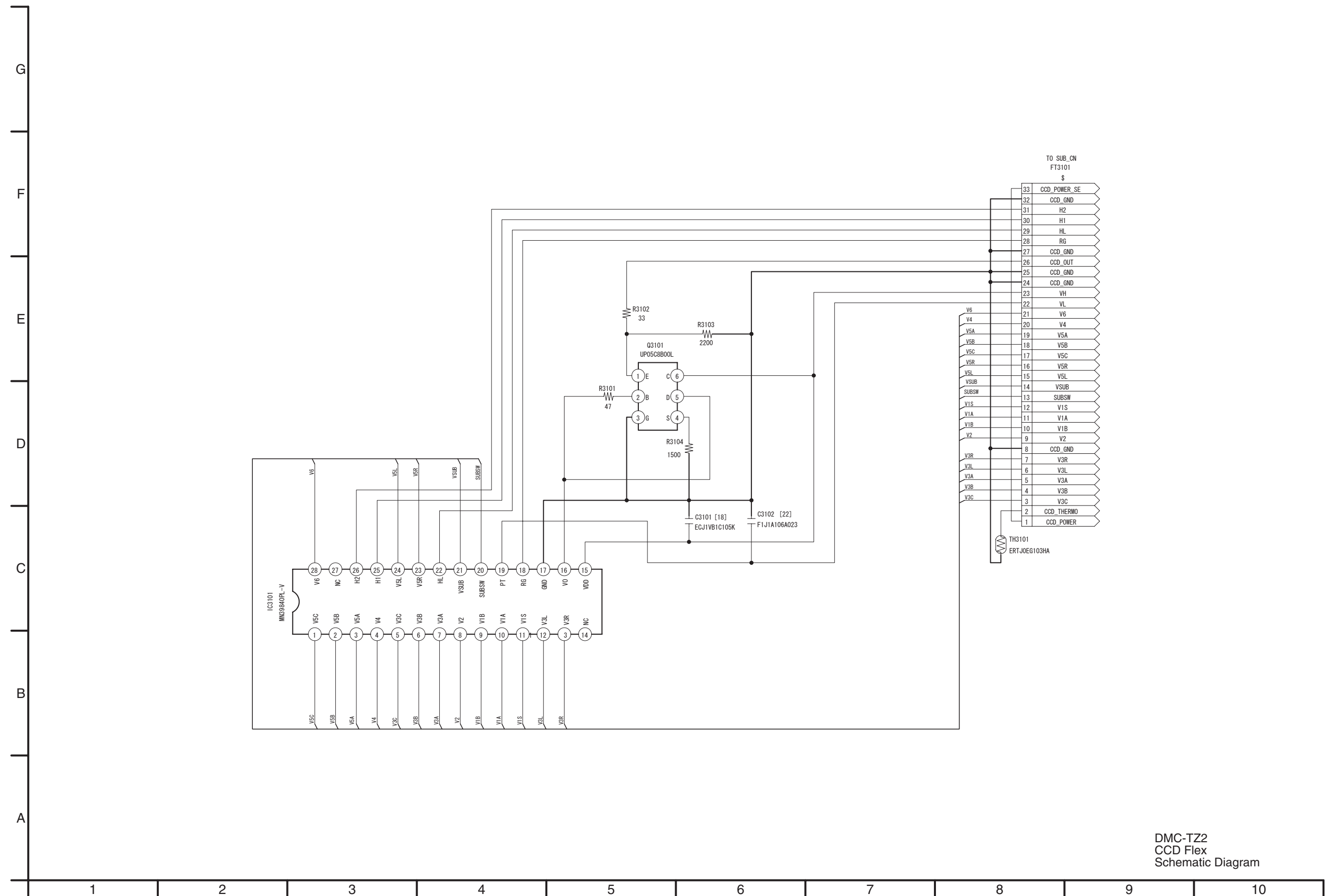

DMC-TZ2
CCD Flex
Schematic Diagram

S3.6. CCD Flex Schematic Diagram (DMC-TZ3)

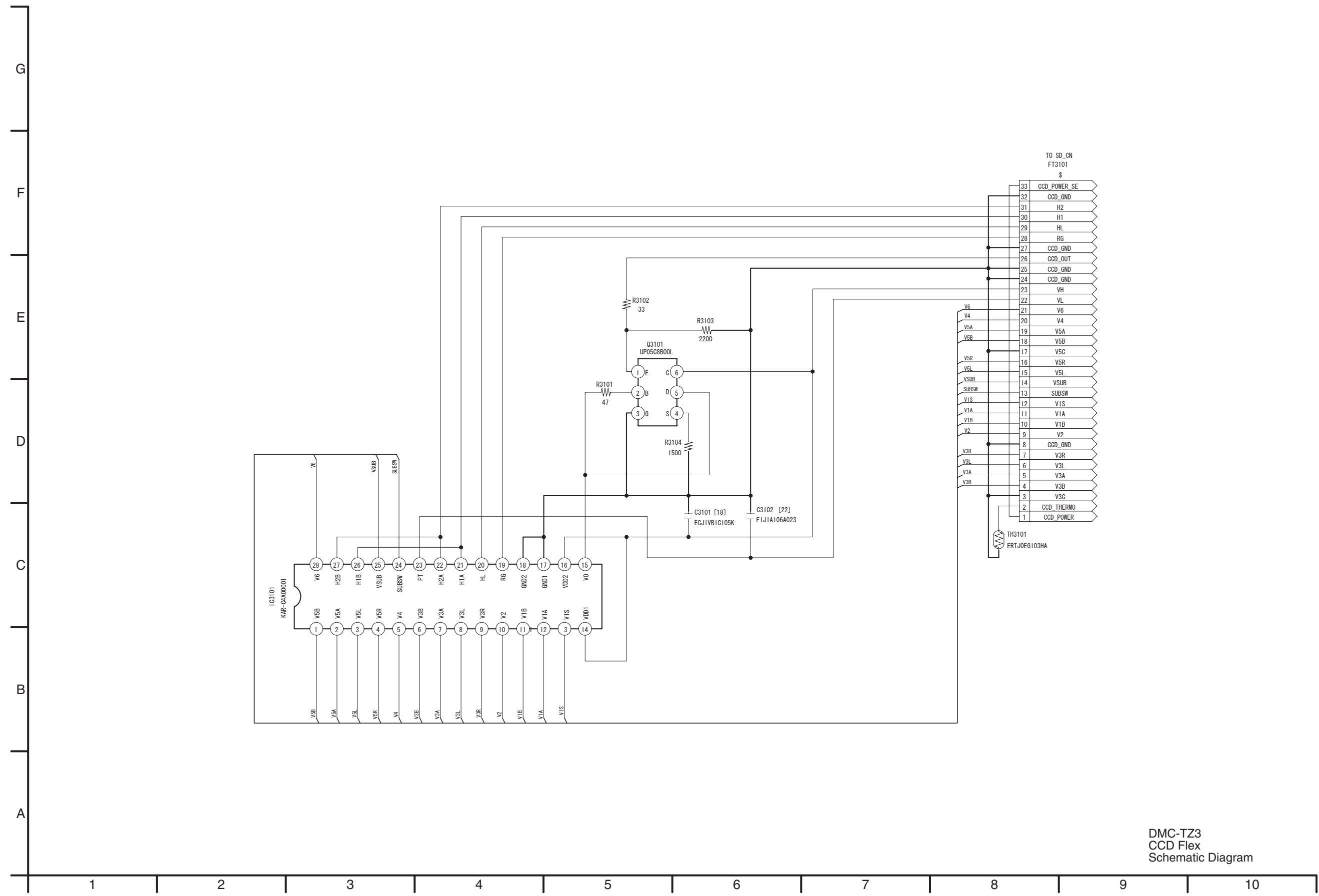

DMC-TZ3
CCD Flex
Schematic Diagram

S3.7. Lens Flex Schematic Diagram

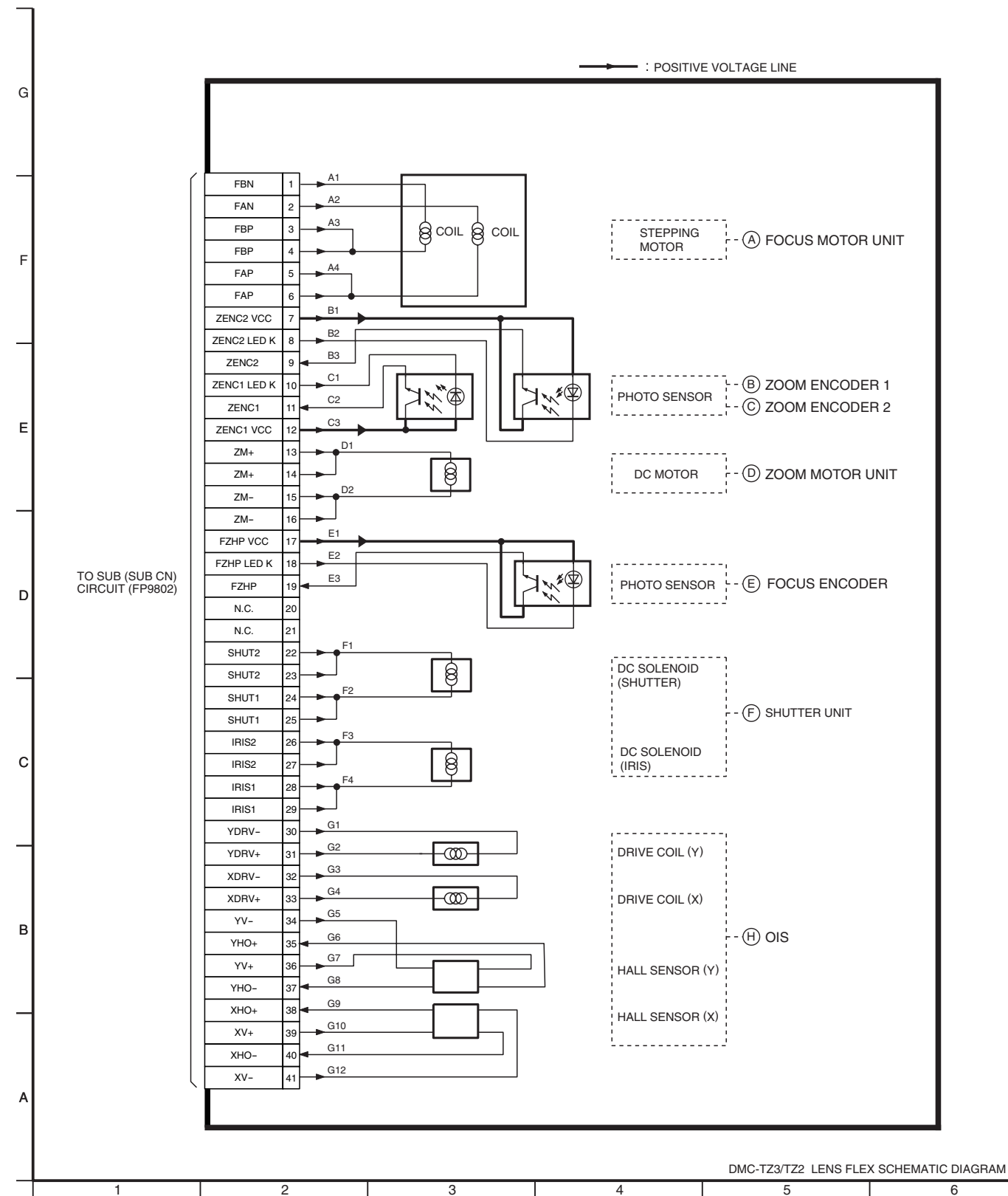

S4. Print Circuit Board

S4.1. Flash P.C.B.

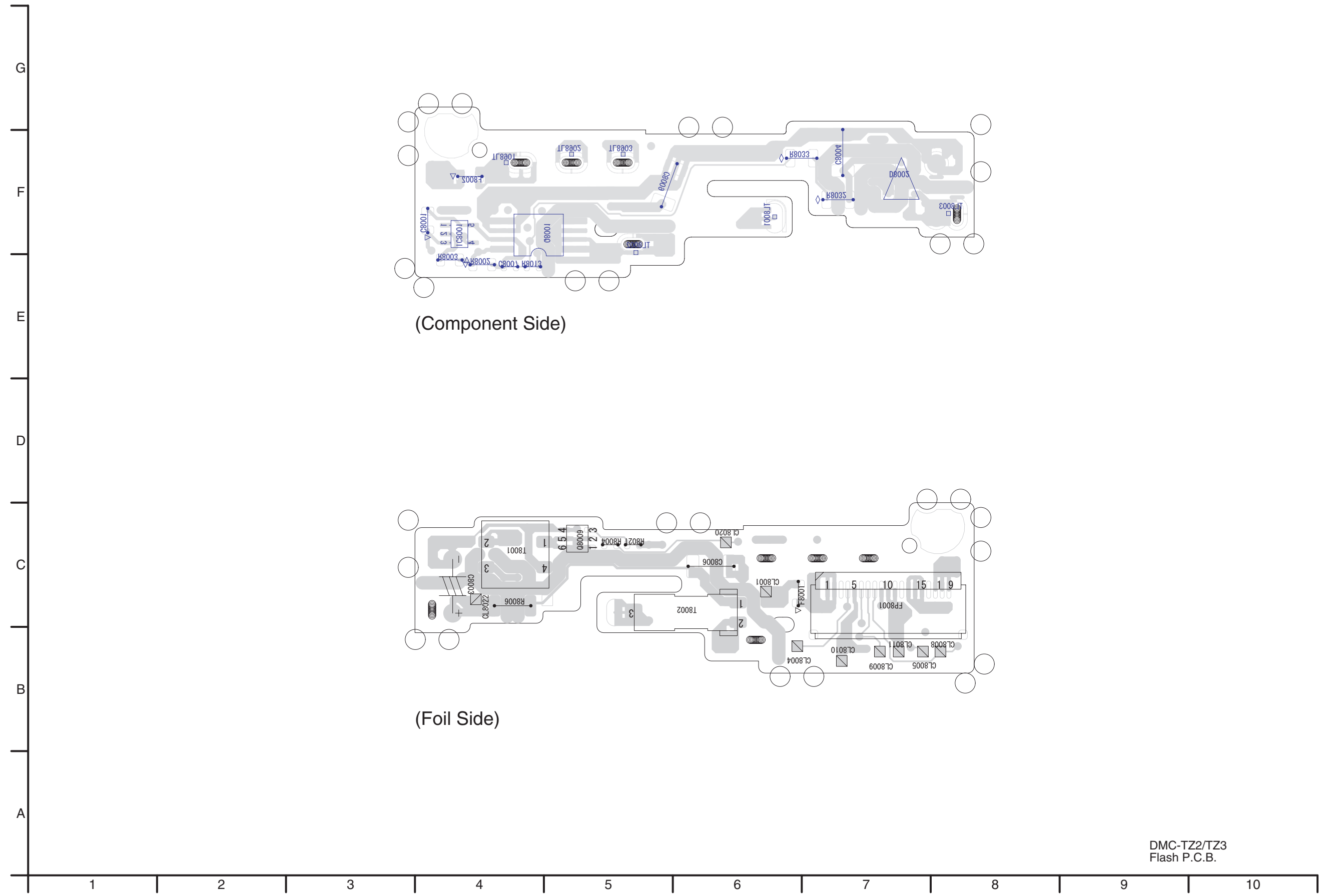

S4.2. Top Operation P.C.B. / S4.3. AF Assist P.C.B.

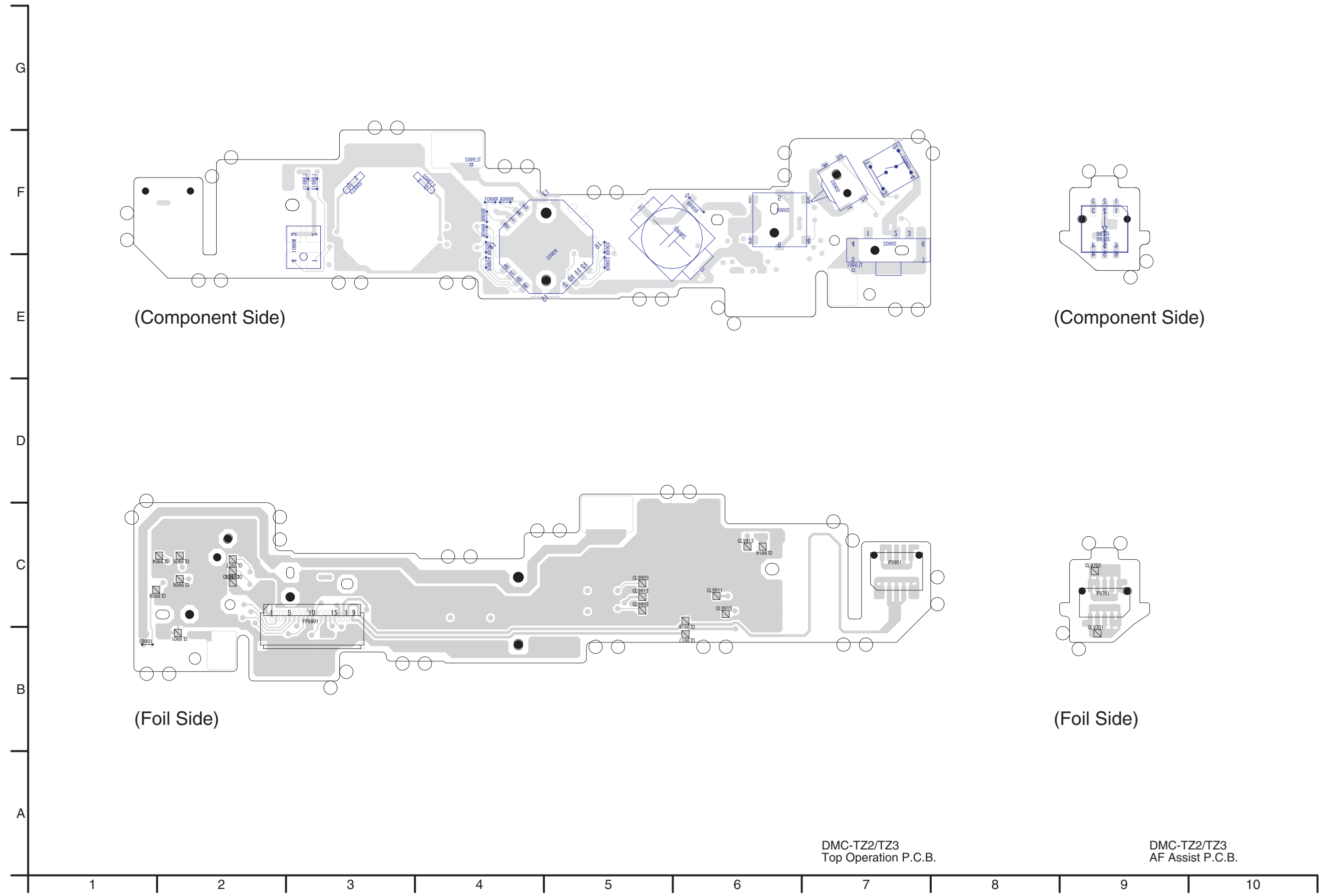

S4.4. CCD Flex P.C.B. (DMC-TZ2)

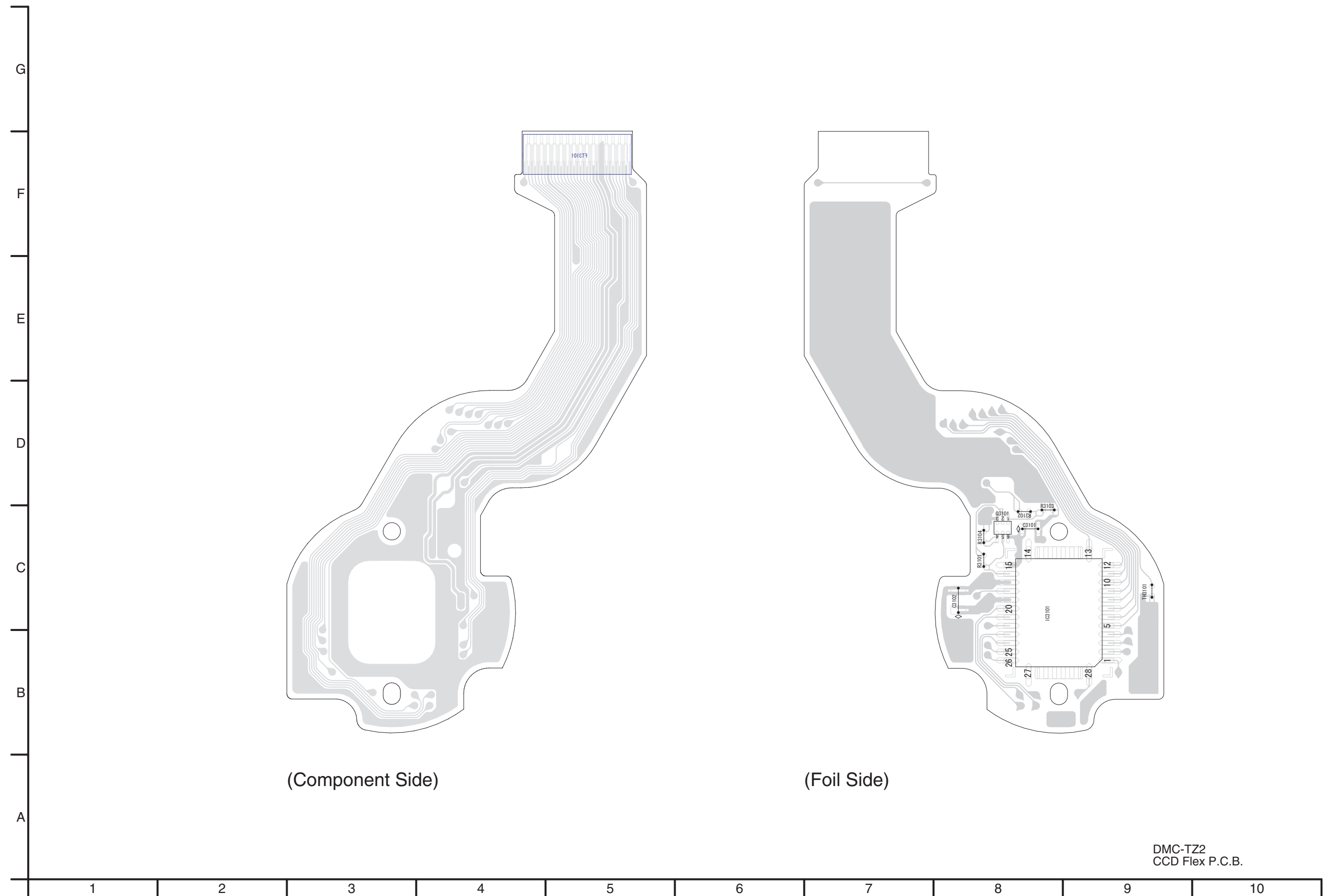

DMC-TZ2
CCD Flex P.C.B.

S4.5. CCD Flex P.C.B. (DMC-TZ3)

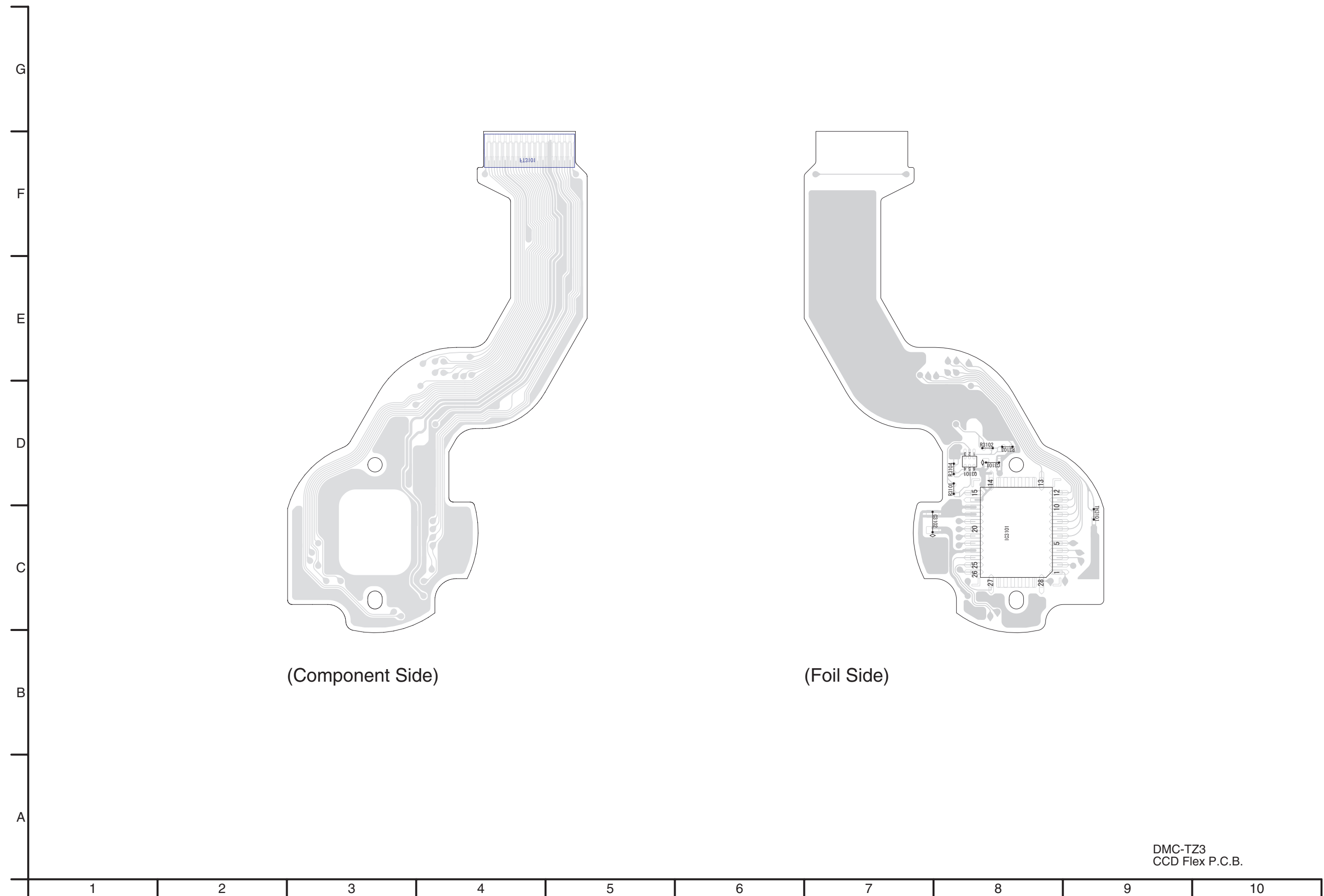

DMC-TZ3
CCD Flex P.C.B.

S4.6. Lens Flex P.C.B.

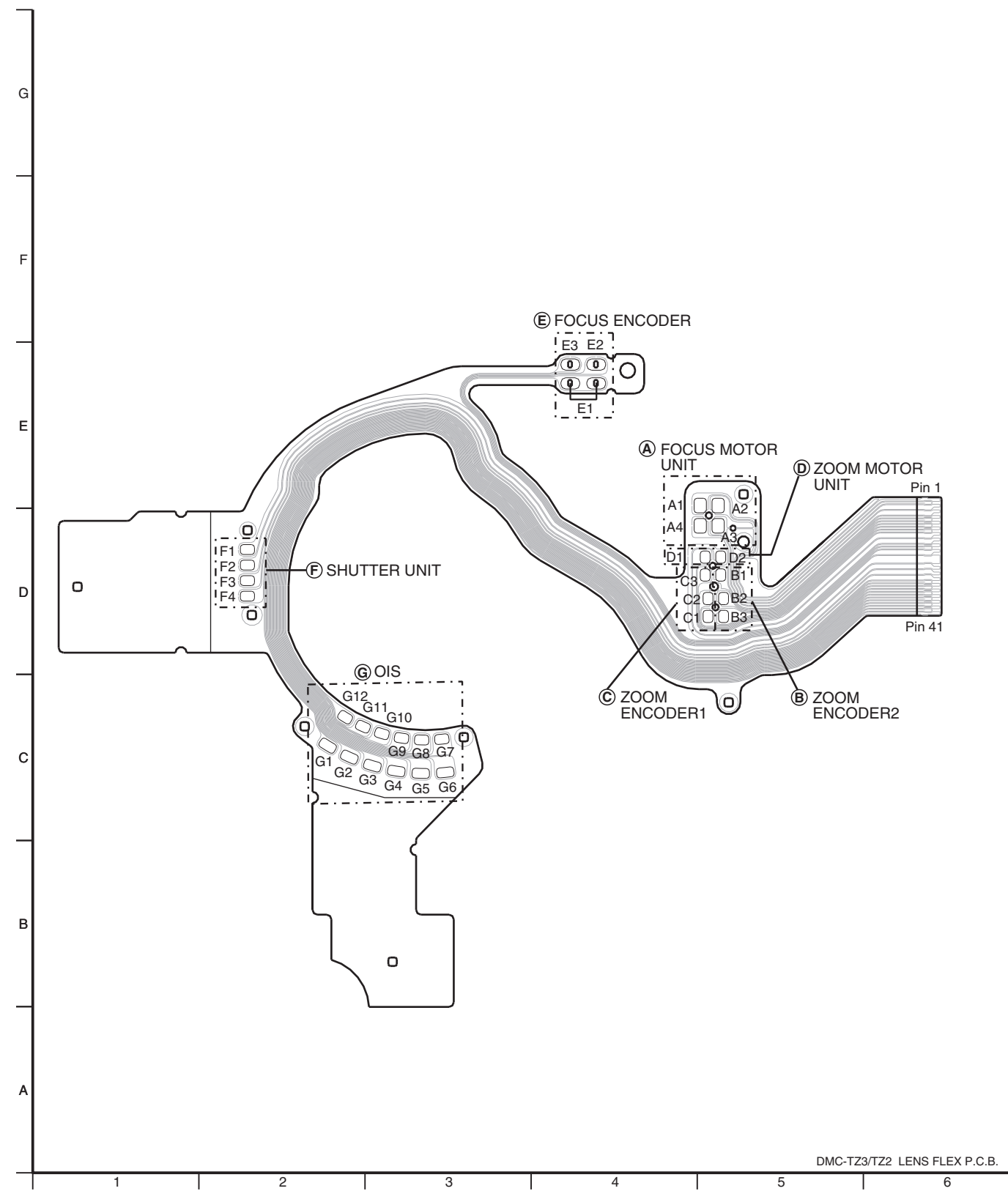

S5. Replacement Parts List

- Note: 1.* Be sure to make your orders of replacement parts according to this list.
2. IMPORTANT SAFETY NOTICE
Components identified with the mark \triangle have the special characteristics for safety.
When replacing any of these components, use only the same type.
3. Unless otherwise specified,
All resistors are in OHMS, K=1,000 OHMS. All capacitors are in MICRO-FARADS (uf), P=uuF.
4. The marking (RTL) indicates the retention time is limited for this item. After the discontinuation of this assembly in production, it will no longer be available.

E.S.D. standards for Electrostatically Sensitive Devices, refer to “PREVENTION OF ELECTROSTATIC DISCHARGE (ESD) TO ELECTROSTATICALLY SENSITIVE (ES) DEVICES” section.

Definition of Parts supplier:

1. Parts marked with [MBI] in the remarks column are supplied from “Matsushita Battery Industrial Co., Ltd.”

Ref.No.	Part No.	Part Name & Description	Pcs	Remarks
##	VEP56047A	MAIN P.C.B.	1	[RTL](TZ3) E.S.D.
##	VEP56047B	MAIN P.C.B.	1	[RTL](TZ2) E.S.D.
##	VEP51013A	SUB P.C.B.	1	[RTL](TZ3) E.S.D.
##	VEP51013B	SUB P.C.B.	1	[RTL](TZ2) E.S.D.
##	VEP58039A	FLASH P.C.B.	1	[RTL] E.S.D.
##	VEP59041A	TOP OPERATION P.C.B.	1	[RTL] E.S.D.
##	VEP59042A	AF ASSIST LED P.C.B.	1	[RTL] E.S.D.
##	VEK0L03	CCD UNIT	1	(TZ2) E.S.D.
##	VEK0L04	CCD UNIT	1	(TZ3) E.S.D.
##	VEP58039A	FLASH P.C.B.	1	[RTL] E.S.D.
C8001	ECJ1VB0J105K	C.CAPACITOR CH 6.3V 1U	1	
C8003	F2A2F8800001	E.CAPACITOR 300V 88U	1	
C8004	F1K2J102A010	C.CAPACITOR 630V 1000P	1	
C8006	F1K2J333A031	C.CAPACITOR 630V 0.033U	1	
C8007	F1G1A1040006	C.CAPACITOR CH 10V 0.1U	1	
C8009	ECJ3YB0J106K	C.CAPACITOR CH 6.3V 10U	1	
D8002	B0HDCS000001	DIODE	1	E.S.D.
△ F8001	ERBSE1R25U	FUSE 32V 1.25A	1	
△ F8002	ERBSE1R50U	FUSE 32V 1.5A	1	
FP8001	K1MN19BA0209	CONNECTOR 19P	1	
IC8001	C0ZBZ0000914	IC	1	E.S.D.
Q8001	B1JBLP000012	TRANSISTOR	1	E.S.D.
Q8009	B1DFCG000020	TRANSISTOR	1	E.S.D.
R8002	ERJ3GEYJ104	M.RESISTOR CH 1/10W 100K	1	
R8003	ERJ3GEYJ330	M.RESISTOR CH 1/10W 33	1	
R8004	D0YAR0000007	M.RESISTOR CH 1/16W 0	1	
R8006	ERJ8GEYJ105V	M.RESISTOR CH 1/8W 1M	1	
R8013	ERJ2RHD153X	M.RESISTOR CH 1/16W 15K	1	
R8021	ERJ2GEJ153	M.RESISTOR CH 1/16W 15K	1	
R8032	ERJ6RED105	M.RESISTOR CH 1/16W 1M	1	
R8033	ERJ6RED105	M.RESISTOR CH 1/16W 1M	1	
T8001	G5D1A0000061	TRANSFORMER	1	
T8002	G5F1A0000024	TRANSFORMER	1	
##	VEP59041A	TOP OPERATION P.C.B.	1	[RTL] E.S.D.
ET9901	K4BC01D00001	EARTH TERMINAL	1	
ET9902	K4BC01D00001	EARTH TERMINAL	1	
FP9901	K1MN19BA0209	CONNECTOR 19P	1	
△ LB9911	J0JCC0000317	FILTER	1	
△ LB9912	J0JCC0000317	FILTER	1	
M9901	L0CZAA000007	MICROPHONE UNITS	1	
P9901	K1KA10BA0190	CONNECTOR 10P	1	
R9901	ERJ2GEJ242	M.RESISTOR CH 1/16W 2.4K	1	
R9902	ERJ2GEJ432	M.RESISTOR CH 1/16W 4.3K	1	
R9903	ERJ2GEJ822	M.RESISTOR CH 1/16W 8.2K	1	
R9904	ERJ2GEJ243	M.RESISTOR CH 1/16W 24K	1	
R9905	ERJ2GEJ242	M.RESISTOR CH 1/16W 2.4K	1	

Ref.No.	Part No.	Part Name & Description	Pcs	Remarks
R9906	ERJ2GEJ432	M.RESISTOR CH 1/16W 4.3K	1	
R9907	ERJ2GEJ822	M.RESISTOR CH 1/16W 8.2K	1	
R9908	ERJ2GEJ243	M.RESISTOR CH 1/16W 24K	1	
R9909	ERJ6GEYJ512	M.RESISTOR CH 1/10W 5.1K	1	
S9901	K0F212A00003	SWITCH	1	
S9902	K0D112B00145	SWITCH	1	
S9903	EVQPQ6B55	SWITCH	1	
S9904	K0G199A00012	SWITCH	1	
S9905	K0L1CB000003	SWITCH	1	
ZB9901	K3Z200500014	CONNECTOR	1	
B9901	ML614S/ZT	BATTERY	1	[MBI]
##	VEP59042A	AF ASSIST LED P.C.B.	1	[RTL] E.S.D.
D9701	B3ADB0000100	DIODE	1	E.S.D.
P9701	K1KB10AA0129	CONNECTOR 10P	1	
##	VEK0L03	CCD UNIT	1	(TZ2) E.S.D.
C3101	ECJ1VB1C105K	C.CAPACITOR CH 16V 1U	1	
C3102	F1J1A106A023	C.CAPACITOR CH 10V 10U	1	
Q3101	UP05C8B00L	TRANSISTOR	1	E.S.D.
R3101	ERJ2GEJ470	M.RESISTOR CH 1/16W 47	1	
R3102	ERJ2RKD330	M.RESISTOR CH 1/16W 33	1	
R3103	ERJ2GEJ222	M.RESISTOR CH 1/16W 2.2K	1	
R3104	ERJ2GEJ152	M.RESISTOR CH 1/16W 1.5K	1	
TH3101	ERTJ0EG103HA	THERMISTOR	1	
##	VEK0L04	CCD UNIT	1	(TZ3) E.S.D.
C3101	ECJ1VB1C105K	C.CAPACITOR CH 16V 1U	1	
C3102	F1J1A106A023	C.CAPACITOR CH 10V 10U	1	
Q3101	UP05C8B00L	TRANSISTOR	1	
R3101	ERJ2GEJ470	M.RESISTOR CH 1/16W 47	1	
R3102	ERJ2RKD330	M.RESISTOR CH 1/16W 33	1	
R3103	ERJ2GEJ222	M.RESISTOR CH 1/16W 2.2K	1	
R3104	ERJ2GEJ152	M.RESISTOR CH 1/16W 1.5K	1	
TH3101	ERTJ0EG103HA	THERMISTOR	1	

Ref.No.	Part No.	Part Name & Description	Pcs	Remarks	Ref.No.	Part No.	Part Name & Description	Pcs	Remarks
1	VEP51013B	SUB P.C.B.	1	(TZ2) [RTL] E.S.D.	208	VXP2744	1ST LENS FRAME UNIT	1	
1	VEP51013A	SUB P.C.B.	1	(TZ3) [RTL] E.S.D.	209	VXP2745	BOTH SIDE CAM FRAME UNIT	1	
2	VEP56047B	MAIN P.C.B.	1	(TZ2) [RTL] E.S.D.	210	VXP2746	2ND LENS FRAME UNIT	1	
2	VEP56047A	MAIN P.C.B.	1	(TZ3) [RTL] E.S.D.	211	VXP2748	3RD LENS FRAME UNIT	1	
3	L0AA01A00027	SPEAKER	1		212	VXP2754	DRIVE FRAME UNIT	1	
4	ML614S/ZT	BATTERY	1	[MBI](B9901)	213	VXQ1502	FIX FRAME UNIT	1	
5	VGQ9404	TOP PCB SHEET	1		214	VXQ1504	MASTER FLANGE UNIT	1	
6	VGU0B03	POWER KNOB	1		215	L6HA86ND0001	FOCUS MOTOR UNIT	1	
7	VGU0B04	OIS BUTTON	1		216	VXW0868	LENS UNIT	1	
8	VEP59041A	TOP OPERATION P.C.B.	1	[RTL] E.S.D.	B1	VHD1876	SCREW	1	
9	VEP59042A	AF ASSIST LED P.C.B.	1	[RTL] E.S.D.	B2	VHD1876	SCREW	1	
10	VYF3145	TOP COVER UNIT	1		B3	VHD1853	SCREW	1	(-K)(-A)
11	VYK2C42	TOP ORNAMENT UNIT	1	(TZ2)	B3	VHD1693	SCREW	1	(-S)
11	VYK2C41	TOP ORNAMENT UNIT	1	(TZ3)	B4	VHD1853	SCREW	1	(-K)(-A)
12	VYQ4009	MIC DAMPER	1		B4	VHD1693	SCREW	1	(-S)
13	VEK0K94	FLASH UNIT	1		B5	VHD1853	SCREW	1	(-K)(-A)
14	VGQ9354	CONDENSER COVER	1		B5	VHD1693	SCREW	1	(-S)
15	VMB4024	BATTERY SPRING	1		B6	VHD1854	SCREW	1	(-K)(-A)
16	VWJ1955	FPC	1		B6	VHD1841	SCREW	1	(-S)
17	VEP58039A	FLASH P.C.B.	1	[RTL] E.S.D.	B7	VHD1854	SCREW	1	(-K)(-A)
19	VKF4188	JACK DOOR	1	(-K)TZ2	B7	VHD1841	SCREW	1	(-S)
19	VKF4189	JACK DOOR	1	(-K)TZ3	B8	VHD1854	SCREW	1	(-K)(-A)
19	VKF4187	JACK DOOR	1	(-S)	B8	VHD1841	SCREW	1	(-S)
19	VKF4190	JACK DOOR	1	(-A)	B9	VHD1854	SCREW	1	(-K)(-A)
23	VYQ4019	BATTERY FRAME UNIT	1	(-K)TZ2	B9	VHD1841	SCREW	1	(-S)
23	VYQ4017	BATTERY FRAME UNIT	1	(-K)TZ3	B10	VHD1854	SCREW	1	(-K)(-A)
23	VYQ4014	BATTERY FRAME UNIT	1	(-S)	B10	VHD1841	SCREW	1	(-S)
23	VYQ4018	BATTERY FRAME UNIT	1	(-A)	B11	VHD1877	SCREW	1	(-K)(-A)
24	VMS7822	BATTERY DOOR SHAFT	1		B11	VHD1876	SCREW	1	(-S)
25	VMS7823	JACK DOOR SHAFT	1		B12	VHD1877	SCREW	1	(-K)(-A)
26	VYF3143	BATTERY DOOR UNIT	1	(-K)TZ2	B12	VHD1876	SCREW	1	(-S)
26	VYF3140	BATTERY DOOR UNIT	1	(-K)TZ3	B13	VHD1909	SCREW	1	
26	VYF3142	BATTERY DOOR UNIT	1	(-S)	B14	VHD1909	SCREW	1	
26	VYF3141	BATTERY DOOR UNIT	1	(-A)	B15	VHD1921	SCREW	1	
27	VGK3312	FRONT GRIP	1		B16	VHD1921	SCREW	1	
28	VGK3321	GRIP FIX	1	(TZ2)	B17	VHD1924	SCREW	1	
28	VGK3313	GRIP FIX	1	(TZ3)	B19	VHD1924	SCREW	1	
29	VGK3315	STRAP HOLDER	1		B20	VHD1926	SCREW	1	
30	VGQ9317	TRIPOD	1		B21	VHD1924	SCREW	1	
30	VMP8808	LENS PLATE	1		B22	VHD1924	SCREW	1	
31	VGQ9356	PCB SPACER	1		B23	VHD1678	SCREW	1	
33	VEK0L23	HEAT RADIATION SHEET	1	(TZ3)	B24	XQN16+BJ3FN	SCREW	1	
35	VMC2036	PCB PLATE	1		B25	VHD1909	SCREW	1	
36	VMP8808	LENS PLATE	1		B201	VHD1871	SCREW	1	
37	VWJ1956	FPC	1		B202	VHD1871	SCREW	1	
38	VGL1230	REAR PANEL LIGHT	1		B203	VHD1871	SCREW	1	
39	VGQ9162	CURSOL TAPE	1		B204	XQN14+CJ4FJ	SCREW	1	
40	VGQ9162	CURSOL TAPE	1		B205	XQN14+CJ4FJ	SCREW	1	
41	VUKM7124	REAR CASE UNIT	1	(-K)TZ2	B206	XQN14+CJ4FJ	SCREW	1	
41	VUKM7101	REAR CASE UNIT	1	(-S)TZ2	B207	XQN14+CJ4FJ	SCREW	1	
41	VUKM7103	REAR CASE UNIT	1	(-K)TZ3	B208	XQN14+CJ4FJ	SCREW	1	
41	VUKM7100	REAR CASE UNIT	1	(-S)TZ3	B209	XQN14+CJ4FJ	SCREW	1	
41	VUKM7102	REAR CASE UNIT	1	(-A)	B210	XQN14+CJ4FJ	SCREW	1	
42	VGU0B02	CURSOR BUTTON	1		B211	VHD1871	SCREW	1	
43	VYK2C54	LCD UNIT	1	(TZ2)					
43	VYK2C31	LCD UNIT	1	(TZ3)					
44	VYK2C53	FRONT CASE UNIT	1	(-K)TZ2					
44	VYK2C52	FRONT CASE UNIT	1	(-S)TZ2					
44	VYK2C50	FRONT CASE UNIT	1	(-K)TZ3					
44	VYK2C49	FRONT CASE UNIT	1	(-S)TZ3					
44	VYK2C51	FRONT CASE UNIT	1	(-A)					
45	VGQ9316	LENS ORNAMENT	1						
46	F2A2F8800001	E.CAPACITOR 300V 88UF	1	(C8003)					
47	VEK0L24	LENS BARRIER SHEET	1	(TZ2)					
48	VGQ9498	CAPACITOR SHEET	1						
49	VGQ9503	SWITCH SHEET	1						
50	VGQ9505	IC SHEET	1						
201	VDL1944	OPTICAL FILTER	1						
202	VEK0L03	CCD UNIT	1	(TZ2) E.S.D.					
202	VEK0L04	CCD UNIT	1	(TZ3) E.S.D.					
203	VMX3600	CCD CUSHION RUBBER	1						
204	L6DABCGD0001	ZOOM MOTOR UNIT	1						
205	B3NAA0000132	PHOTO COUPLER	1						
207	VDW1412	2ND/3RD DIRECT FRAME	1						

Ref.No.	Part No.	Part Name & Description	Pcs	Remarks	Ref.No.	Part No.	Part Name & Description	Pcs	Remarks
301	VPF1137	CAMERA BAG	1	(EXCEPT P/PC)	311	VQT1D48	O/I PC CONNECTION (FRENCH)	1	EF
△ 302	DE-A46AA	BATTERY CHARGER	1	EB,EF,EG,EGM,GN	311	VQT1D46	O/I PC CONNECTION (GERMAN/FRENCH/ITALIAN/ DUTCH)	1	EG
△ 302	DE-A46BA	BATTERY CHARGER	1	EE,GC,GK,GD,SG	311	VQT1D47	O/I PC CONNECTION (SPANISH/PORTUGUESE/ SWEDISH/DANISH)	1	EGM
△ 302	DE-A46CA	BATTERY CHARGER	1	GT	311	VQT1D51	O/I PC CONNECTION (ENGLISH/ARABIC/PERSIAN/ CHINESE(TRADITIONAL))	1	GC,SG
△ 302	DE-A45BA	BATTERY CHARGER	1	PL	311	VQT1D53	O/I PC CONNECTION (CHINESE(SIMPLIFIED))	1	GK
303	K1HA08CD0013	USB CABLE	1	(EXCEPT P/PC)	311	VQT1D52	O/I PC CONNECTION (CHINESE(TRADITIONAL))	1	GT
304	K1HA08CD0014	AV CABLE	1	(EXCEPT P/PC)	311	VQT1D45	O/I PC CONNECTION (ENGLISH/SPANISH/ PORTUGUESE)	1	PL
305	VFC4090	HAND STRAP	1	(EXCEPT P/PC)	311	VQT1D54	O/I PC CONNECTION (KOREAN)	1	GD
306	VFF0358-S	CD-ROM	1	(EXCEPT P/PC)	312	VQT1D77	O/I SOFTWARE (ENGLISH)	1	EB,GN
307	VPK3326	PACKING CASE	1	(-K)2EB,2EE,2EF,2EG,2EGM, 2GC,2GN	312	VQT1D78	O/I SOFTWARE (RUSSIAN/UKRAINIAN)	1	EE
307	VPK3260	PACKING CASE	1	(-S)2EB,2EE,2EF,2EG,2EGM, 2GC,2GN,2GT,2PL	312	VQT1D76	O/I SOFTWARE (FRENCH)	1	EF
307	VPK3327	PACKING CASE	1	2GKK	312	VQT1D74	O/I SOFTWARE (GERMAN/FRENCH/ITALIAN/ DUTCH)	1	EG
307	VPK3261	PACKING CASE	1	2GKS	312	VQT1D75	O/I SOFTWARE (SPANISH/PORTUGUESE/ SWEDISH/DANISH)	1	EGM
307	VPK3320	PACKING CASE	1	(-K)3EB,3EE,3EF,3EG,3EGM, 3GC,3GD,3GN,3GT,3PL,3SG	312	VQT1D79	O/I SOFTWARE (ENGLISH/ARABIC/PERSIAN/ CHINESE(TRADITIONAL))	1	GC,SG
307	VPK3257	PACKING CASE	1	(-S)3EB,3EE,3EF,3EG,3EGM, 3GC,3GN,3GT,3PL,3SG	312	VQT1D81	O/I SOFTWARE (CHINESE(SIMPLIFIED))	1	GK
307	VPK3324	PACKING CASE	1	(-A)3EB,3EE,3EF,3EG,3EGM, 3GC,3SG	312	VQT1D80	O/I SOFTWARE (CHINESE(TRADITIONAL))	1	GT
307	VPK3321	PACKING CASE	1	3GKK	312	VQT1D73	O/I SOFTWARE (ENGLISH/SPANISH/ PORTUGUESE)	1	PL
307	VPK3258	PACKING CASE	1	3GKS	312	VQT1D82	O/I SOFTWARE (KOREAN)	1	GD
308	VPN6549	CUSHION	1	(EXCEPT P/PC)	313	VYQ3680	BATTERY CARRYING CASE U	1	(EXCEPT P/PC)
309	VPF1100	BAG, POLYETHYLENE	1	EB,EE,EF,GD,GK,GN,GT	△ 314	K2CT3CA00004	AC CABLE W/PLUG	1	EB,GC,SG
309	VPF1132	BAG, POLYETHYLENE	1	EG,EGM,GC,PL,SG	△ 315	K2CQ2CA00006	AC CABLE W/PLUG	1	EE,EF,EG,EGM,GC,SG
△ 310	VQT1B74	INSTRUCTION BOOK (ENGLISH)	1	EB	△ 316	K2CA2CA00020	AC CABLE W/PLUG	1	GK
△ 310	VQT1B75	INSTRUCTION BOOK (RUSSIAN)	1	EE	△ 316	K2CA2CA00027	AC CABLE W/PLUG	1	GT
△ 310	VQT1B76	INSTRUCTION BOOK (UKRAINIAN)	1	EE	△ 317	K2CJ2DA00008	AC CABLE W/PLUG	1	GN
△ 310	VQT1B67	INSTRUCTION BOOK (FRENCH)	1	EF,EG	△ 318	RJA0078-1X	AC CABLE W/PLUG	1	GD
△ 310	VQT1B66	INSTRUCTION BOOK (GERMAN)	1	EG	△ 320	-----	BATTERY	1	(EXCEPT P/PC)
△ 310	VQT1B68	INSTRUCTION BOOK (ITALIAN)	1	EG					
△ 310	VQT1B69	INSTRUCTION BOOK (DUTCH)	1	EG					
△ 310	VQT1B70	INSTRUCTION BOOK (SPANISH)	1	EGM					
△ 310	VQT1B71	INSTRUCTION BOOK (PORTUGUESE)	1	EGM					
△ 310	VQT1B72	INSTRUCTION BOOK (SWEDISH)	1	EGM					
△ 310	VQT1B73	INSTRUCTION BOOK (DANISH)	1	EGM					
△ 310	VQT1B77	INSTRUCTION BOOK (ENGLISH)	1	GC,SG					
△ 310	VQT1B78	INSTRUCTION BOOK (CHINESE(TRADITIONAL))	1	GC,SG					
△ 310	VQT1B79	INSTRUCTION BOOK (ARABIC)	1	GC,SG					
△ 310	VQT1B80	INSTRUCTION BOOK (PERSIAN)	1	GC,SG					
△ 310	VQT1B82	INSTRUCTION BOOK (CHINESE(SIMPLIFIED))	1	GK					
△ 310	VQT1B83	INSTRUCTION BOOK (ENGLISH)	1	GN					
△ 310	VQT1B81	INSTRUCTION BOOK (CHINESE(TRADITIONAL))	1	GT					
△ 310	VQT1B63	INSTRUCTION BOOK (ENGLISH)	1	PL					
△ 310	VQT1B64	INSTRUCTION BOOK (SPANISH)	1	PL					
△ 310	VQT1B65	INSTRUCTION BOOK (PORTUGUESE)	1	PL					
△ 310	VQT1B84	INSTRUCTION BOOK (KOREAN)	1	GD					
311	VQT1D49	O/I PC CONNECTION (ENGLISH)	1	EB,GN					
311	VQT1D50	O/I PC CONNECTION (RUSSIAN/UKRAINIAN)	1	EE					

S6. Exploded View

S6.1. Frame and Casing Section

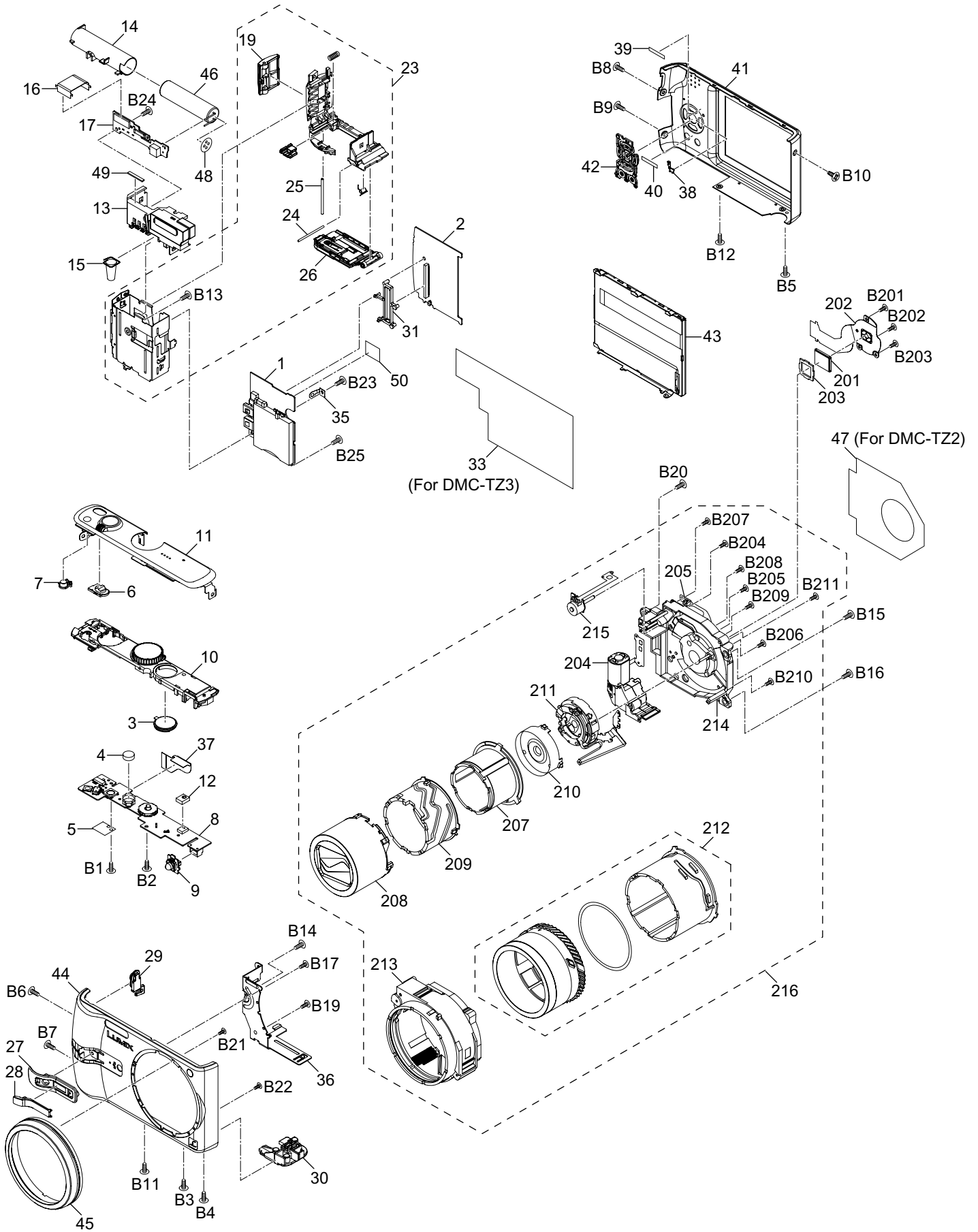

S6.2. Packing Parts and Accessories Section (1)

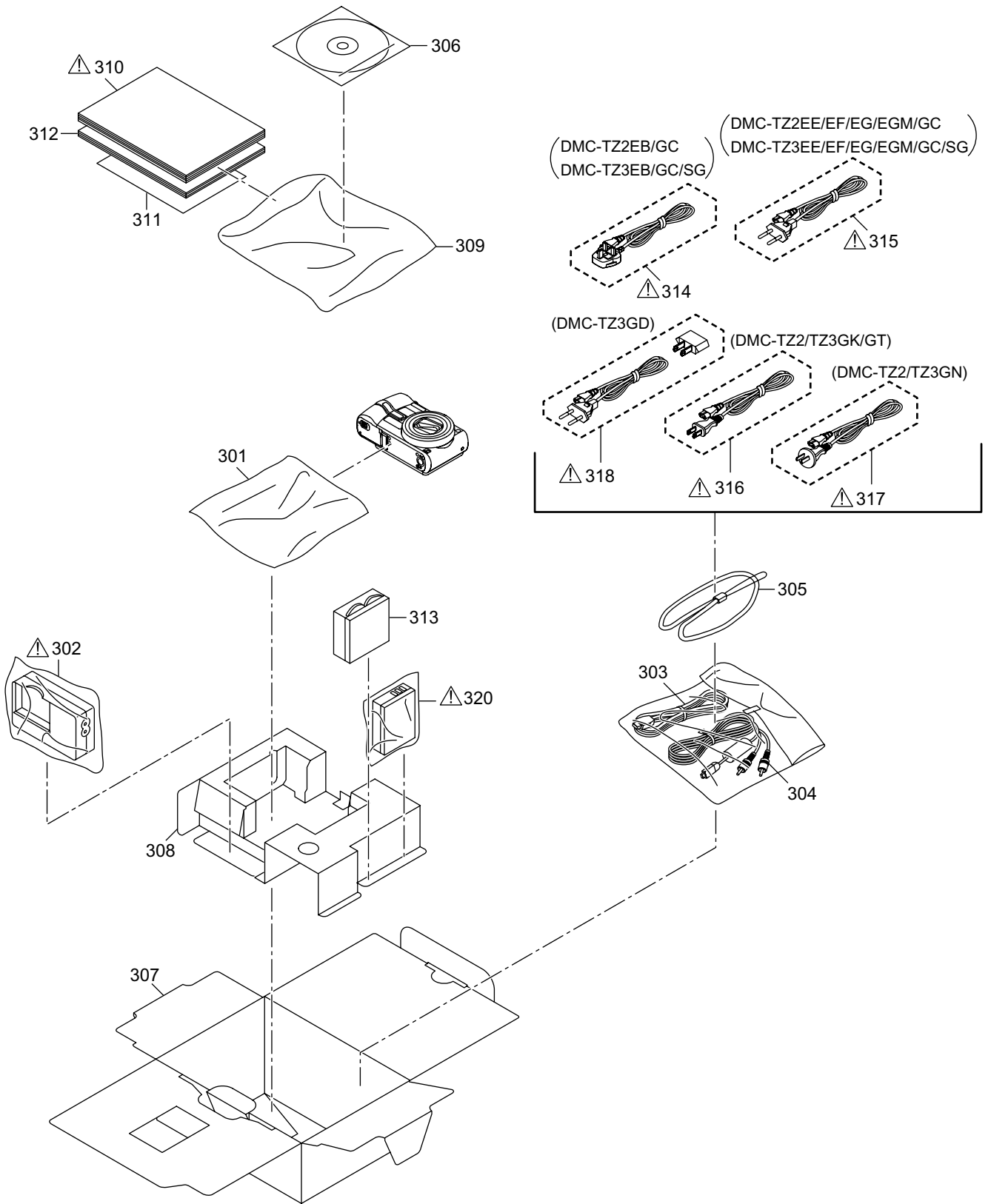

S6.3. Packing Parts and Accessories Section (2)

