

Service Manual

Digital Camera

LUMIX

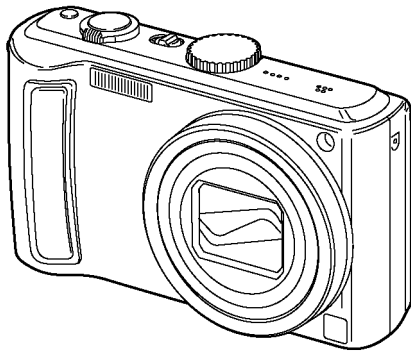

Model No. **DMC-TZ4P**
DMC-TZ4PC
DMC-TZ4PL
DMC-TZ4EB
DMC-TZ4EE
DMC-TZ4EF
DMC-TZ4EG
DMC-TZ4E
DMC-TZ11GC
DMC-TZ11GK
DMC-TZ11GN
DMC-TZ11GT
DMC-TZ11GJ

VOL.1

Colours

(S).....Silver Type

(K).....Black Type (except GT)

WARNING

This service information is designed for experienced repair technicians only and is not designed for use by the general public. It does not contain warnings or cautions to advise non-technical individuals of potential dangers in attempting to service a product. Products powered by electricity should be serviced or repaired only by experienced professional technicians. Any attempt to service or repair the product or products dealt with in this service information by anyone else could result in serious injury or death.

Panasonic®

© 2008 Matsushita Electric Industrial Co., Ltd. All rights reserved. Unauthorized copying and distribution is a violation of law.

TABLE OF CONTENTS

	PAGE	PAGE
1 Safety Precaution	3	
1.1. General Guidelines	3	
1.2. Leakage Current Cold Check	3	
1.3. Leakage Current Hot Check (See Figure 1).....	3	
1.4. How to Discharge the Capacitor on Flash PCB.....	4	
2 Warning	5	
2.1. Prevention of Electrostatic Discharge (ESD) to Electrostatic Sensitive (ES) Devices	5	
2.2. How to Recycle the Lithium Ion Battery (U.S. Only).....	5	
2.3. Caution for AC Cord (For EB/GC/SG)	6	
2.4. How to Replace the Lithium Battery.....	7	
3 Service Navigation	8	
3.1. Introduction	8	
3.2. General Description About Lead Free Solder (PbF)	8	
3.3. Important Notice 1:(Other than U.S.A. and Canadian Market)	8	
3.4. How to Define the Model Suffix (NTSC or PAL model)	9	
4 Specifications	12	
5 Location of Controls and Components	14	
6 Service Mode	16	
6.1. Error Code Memory Function	16	
7 Service Fixture & Tools	19	
7.1. Service Fixture and Tools	19	
7.2. When Replacing the Main PCB	19	
7.3. Service Position	19	
8 Disassembly and Assembly Instructions	21	
8.1. Disassembly Flow Chart.....	21	
8.2. PCB Location.....	21	
8.3. Disassembly Procedure	22	
8.4. Disassembly Procedure for the Lens	27	
8.5. Assembly Procedure for Lens	30	
8.6. Removal of the CCD Unit	34	
8.7. Removal of the Zoom Motor Unit	35	
8.8. Removal of the Focus Motor Unit.....	35	
8.9. The Applyment of Grease Method.....	36	
9 Measurements and Adjustments	37	
9.1. Matrix Chart for Replaced Part and Necessary Adjustment.....	37	
10 Maintenance	38	
10.1. Cleaning Lens, Viewfinder and LCD Panel.....	38	

1 Safety Precaution

1.1. General Guidelines

1. IMPORTANT SAFETY NOTICE

There are special components used in this equipment which are important for safety. These parts are marked by \triangle in the Schematic Diagrams, Circuit Board Layout, Exploded Views and Replacement Parts List. It is essential that these critical parts should be replaced with manufacturer's specified parts to prevent X-RADIATION, shock fire, or other hazards. Do not modify the original design without permission of manufacturer.

2. An Isolation Transformer should always be used during the servicing of AC Adaptor whose chassis is not isolated from the AC power line. Use a transformer of adequate power rating as this protects the technician from accidents resulting in personal injury from electrical shocks. It will also protect AC Adaptor from being damaged by accidental shorting that may occur during servicing.
3. When servicing, observe the original lead dress. If a short circuit is found, replace all parts which have been overheated or damaged by the short circuit.
4. After servicing, see to it that all the protective devices such as insulation barriers, insulation papers shields are properly installed.
5. After servicing, make the following leakage current checks to prevent the customer from being exposed to shock hazards.

1.2. Leakage Current Cold Check

1. Unplug the AC cord and connect a jumper between the two prongs on the plug.
2. Measure the resistance value, with an ohmmeter, between the jumpered AC plug and each exposed metallic cabinet part on the equipment such as screwheads, connectors, control shafts, etc. When the exposed metallic part has a return path to the chassis, the reading should be between $1M\Omega$ and $5.2M\Omega$. When the exposed metal does not have a return path to the chassis, the reading must be infinity.

1.3. Leakage Current Hot Check (See Figure 1)

1. Plug the AC cord directly into the AC outlet. Do not use an isolation transformer for this check.
2. Connect a $1.5k\Omega$, 10 W resistor, in parallel with a $0.15\mu F$ capacitor, between each exposed metallic part on the set and a good earth ground, as shown in Figure 1.
3. Use an AC voltmeter, with $1 k\Omega/V$ or more sensitivity, to measure the potential across the resistor.
4. Check each exposed metallic part, and measure the voltage at each point.
5. Reverse the AC plug in the AC outlet and repeat each of the above measurements.
6. The potential at any point should not exceed 0.75 V RMS. A leakage current tester (Simpson Model 229 or equivalent) may be used to make the hot checks, leakage current must not exceed $1/2$ mA. In case a measurement is outside of the limits specified, there is a possibility of a shock hazard, and the equipment should be repaired and rechecked before it is returned to the customer.

Hot-Check Circuit

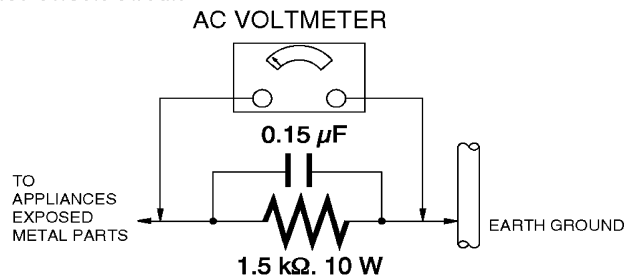

Figure 1

1.4. How to Discharge the Capacitor on Flash PCB

CAUTION:

1. Be sure to discharge the capacitor on FLASH PCB.
2. Be careful of the high voltage circuit on FLASH PCB when servicing.

[Discharging Procedure]

1. Refer to the disassemble procedure and remove the necessary parts/unit.
2. Put the insulation tube onto the lead part of Resistor (ERG5SJ102:1k Ω /5W).
(an equivalent type of resistor may be used.)
3. Put the resistor between both terminals of capacitor on FLASH PCB for approx. 5 seconds.
4. After discharging confirm that the capacitor voltage is lower than 10V using a voltmeter.

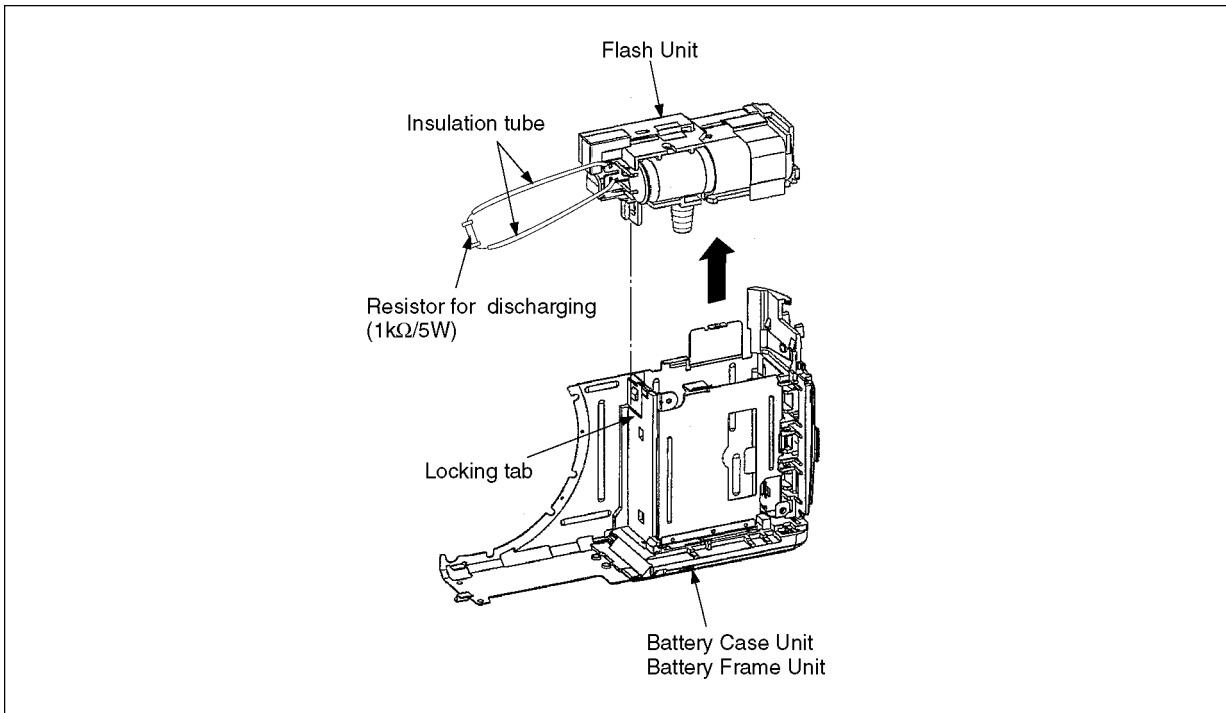

Fig. F1

2 Warning

2.1. Prevention of Electrostatic Discharge (ESD) to Electrostatic Sensitive (ES) Devices

Some semiconductor (solid state) devices can be damaged easily by static electricity. Such components commonly are called Electrostatically Sensitive (ES) Devices.

Examples of typical ES devices are CCD image sensor, IC (integrated circuits) and some field-effect transistors and semiconductor "chip" components.

The following techniques should be used to help reduce the incidence of component damage caused by electrostatic discharge (ESD).

1. Immediately before handling any semiconductor component or semiconductor-equipped assembly, drain off any ESD on your body by touching a known earth ground. Alternatively, obtain and wear a commercially available discharging ESD wrist strap, which should be removed for potential shock reasons prior to applying power to the unit under test.
2. After removing an electrical assembly equipped with ES devices, place the assembly on a conductive surface such as aluminum foil, to prevent electrostatic charge buildup or exposure of the assembly.
3. Use only a grounded-tip soldering iron to solder or unsolder ES devices.
4. Use only an antistatic solder removal device. Some solder removal devices not classified as **antistatic (ESD protected)** can generate electrical charge sufficient to damage ES devices.
5. Do not use freon-propelled chemicals. These can generate electrical charges sufficient to damage ES devices.
6. Do not remove a replacement ES device from its protective package until immediately before you are ready to install it. (Most replacement ES devices are packaged with leads electrically shorted together by conductive foam, aluminum foil or comparable conductive material).
7. Immediately before removing the protective material from the leads of a replacement ES device, touch the protective material to the chassis or circuit assembly into which the device will be installed.

CAUTION:

Be sure no power is applied to the chassis or circuit, and observe all other safety precautions.

8. Minimize bodily motions when handling unpackaged replacement ES devices. (Otherwise harmless motion such as the brushing together of your clothes fabric or the lifting of your foot from a carpeted floor can generate static electricity (ESD) sufficient to damage an ES device).

2.2. How to Recycle the Lithium Ion Battery (U.S. Only)

ENGLISH



A lithium ion/polymer battery that is recyclable powers the product you have purchased. Please call 1-800-8-BATTERY for information on how to recycle this battery.

FRANÇAIS



L'appareil que vous vous êtes procuré est alimenté par une batterie au lithium-ion/polymère recyclable. Pour des renseignements sur le recyclage de la batterie, veuillez composer le 1-800-8-BATTERY.

2.3. Caution for AC Cord (For EB/GC)

2.3.1. Information for Your Safety

IMPORTANT

Your attention is drawn to the fact that recording of pre-recorded tapes or discs or other published or broadcast material may infringe copyright laws.

WARNING

To reduce the risk of fire or shock hazard, do not expose this equipment to rain or moisture.

CAUTION

To reduce the risk of fire or shock hazard and annoying interference, use the recommended accessories only.

FOR YOUR SAFETY

DO NOT REMOVE THE OUTER COVER

To prevent electric shock, do not remove the cover. No user serviceable parts inside. Refer servicing to qualified service personnel.

2.3.2. Caution for AC Mains Lead

For your safety, please read the following text carefully.

This appliance is supplied with a moulded three-pin mains plug for your safety and convenience.

A 5-ampere fuse is fitted in this plug.

Should the fuse need to be replaced please ensure that the replacement fuse has a rating of 5 amperes and it is approved by ASTA or BSI to BS1362

Check for the ASRA mark or the BSI mark on the body of the fuse.



If the plug contains a removable fuse cover you must ensure that it is refitted when the fuse is replaced.

If you lose the fuse cover, the plug must not be used until a replacement cover is obtained.

A replacement fuse cover can be purchased from your local Panasonic Dealer.

If the fitted moulded plug is unsuitable for the socket outlet in your home then the fuse should be removed and the plug cut off and disposed of safely.

There is a danger of severe electrical shock if the cut off plug is inserted into any 13-ampere socket.

If a new plug is to be fitted please observe the wiring code as shown below.

If in any doubt, please consult a qualified electrician.

2.3.2.1. Important

The wires in this mains lead are coloured in accordance with the following code:

Blue	Neutral
Brown	Live

As the colours of the wires in the mains lead of this appliance may not correspond with the coloured markings identifying the terminals in your plug, proceed as follows:

The wire which is coloured BLUE must be connected to the terminal in the plug which is marked with the letter N or coloured BLACK.

The wire which is coloured BROWN must be connected to the terminal in the plug which is marked with the letter L or coloured RED.

Under no circumstances should either of these wires be connected to the earth terminal of the three pin plug, marked with the letter E or the Earth Symbol.

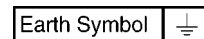

2.3.2.2. Before Use

remove the Connector Cover as follows.

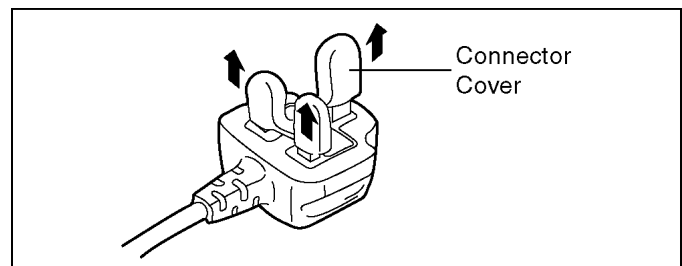

2.3.2.3. How to Replace the Fuse

1. Remove the Fuse Cover with a screwdriver.

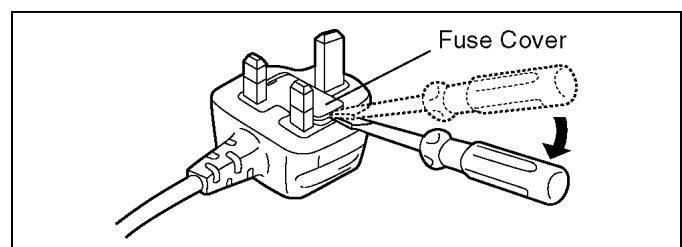

2. Replace the fuse and attach the Fuse cover.

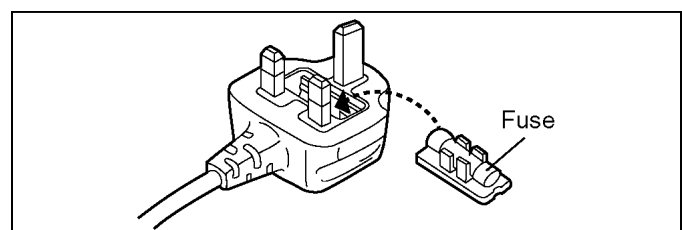

2.4. How to Replace the Lithium Battery

2.4.1. Replacement Procedure

1. Remove the Top Operation PCB. (Refer to Disassembly Procedures.)
2. Remove the Lithium battery (Ref. No. B9901 at component side of Top Operation PCB) and then replace it into new one.

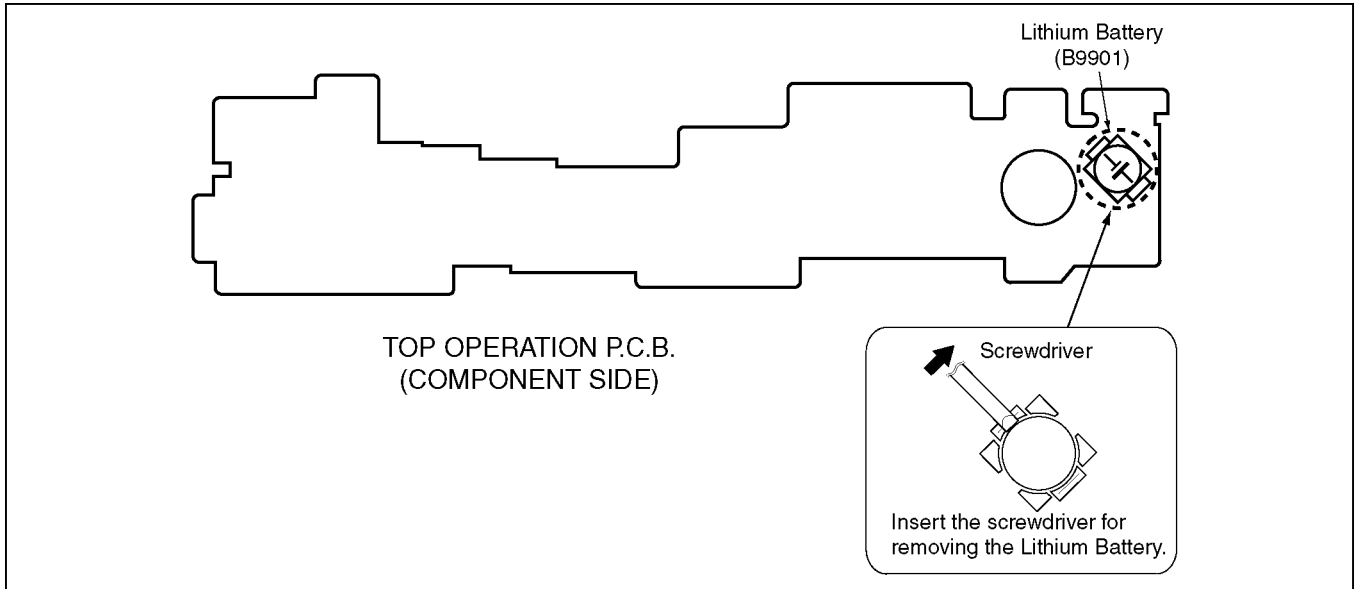

Note:

The lithium battery is a critical component.

(Type No.: ML-421S/ZT **Manufactured by Matsushita Battery Industrial Co.,Ltd.**)

It must never be subjected to excessive heat or discharge.

It must therefore only be fitted in equipment designed specifically for its use.

Replacement batteries must be of the same type and manufacture.

They must be fitted in the same manner and location as the original battery, with the correct polarity contacts observed.

Do not attempt to re-charge the old battery or re-use it for any other purpose.

It should be disposed of in waste products destined for burial rather than incineration.

(For English)

CAUTION

Danger of explosion if battery is incorrectly replaced.

Replace only with the same or equivalent type recommended by the manufacturer.

Dispose of used batteries according to the manufacturer's instructions.

(For German)

ACHTUNG

Explosionsgefahr bei falschem Anbringen der Batterie. Ersetzen Sie nur mit einem äquivalentem vom Hersteller empfohlenem Typ.

Behandeln Sie gebrauchte Batterien nach den Anweisungen des Herstellers.

(For French)

MISE EN GARDE

Une batterie de remplacement inappropriée peut exploser. Ne remplacez qu'avec une batterie identique ou d'un type recommandé par le fabricant. L'élimination des batteries usées doit être faite conformément aux instructions du fabricant.

NOTE:

Above caution is applicable for a battery pack which is for DMC-TZ4/TZ11 series, as well.

3 Service Navigation

3.1. Introduction

This service manual contains technical information, which will allow service personnel's to understand and service this model.

Please place orders using the parts list and not the drawing reference numbers.

If the circuit is changed or modified, the information will be followed by service manual to be controlled with original service manual.

3.2. General Description About Lead Free Solder (PbF)

The lead free solder has been used in the mounting process of all electrical components on the printed circuit boards used for this equipment in considering the globally environmental conservation.

The normal solder is the alloy of tin (Sn) and lead (Pb). On the other hand, the lead free solder is the alloy mainly consists of tin (Sn), silver (Ag) and Copper (Cu), and the melting point of the lead free solder is higher approx.30 °C (86 °F) more than that of the normal solder.

Definition of PCB Lead Free Solder being used

The letter of PbF is printed either foil side or components side on the PCB using the lead free solder. (See right figure)	PbF
--	------------

Service caution for repair work using Lead Free Solder (PbF)

- The lead free solder has to be used when repairing the equipment for which the lead free solder is used.
- (Definition: The letter of **PbF** is printed on the PCB using the lead free solder.)
- To put lead free solder, it should be well molten and mixed with the original lead free solder.
- Remove the remaining lead free solder on the PCB cleanly for soldering of the new IC.
- Since the melting point of the lead free solder is higher than that of the normal lead solder, it takes the longer time to melt the lead free solder.
- Use the soldering iron (more than 70W) equipped with the temperature control after setting the temperature at 350±30 degrees C (662±86 °F).

Recommended Lead Free Solder (Service Parts Route.)

- The following 3 types of lead free solder are available through the service parts route.
 - RFKZ03D01K------(0.3mm 100g Reel)
 - RFKZ06D01K------(0.6mm 100g Reel)
 - RFKZ10D01K------(1.0mm 100g Reel)

Note

* Ingredient: tin (Sn) 96.5%, silver (Ag) 3.0%, Copper (Cu) 0.5%, Cobalt (Co) / Germanium (Ge) 0.1 to 0.3%

3.3. Important Notice 1:(Other than U.S.A. and Canadian Market)

1. The service manual does not contain the following information, because of the impossibility of servicing at component level without concerned equipment/facilities.
 - a. Schematic diagram, Block Diagram and PCB layout of MAIN PCB and SUB PCB.
 - b. Parts list for individual parts for MAIN PCB and SUB PCB.When a part replacement is required for repairing MAIN PCB and/or SUB PCB, replace as an assembled parts. (MAIN PCB/SUB PCB)
2. The following category is/are recycle module part. please send it/them to Central Repair Center.
 - MAIN PCB (VEP56063B)
 - SUB PCB (VEP51020B)

3.4. How to Define the Model Suffix (NTSC or PAL model)







There are six kinds of DMC-TZ4/TZ11, regardless of the colours.

- a) DMC-TZ4P/PC
- b) DMC-TZ4EB/EF/EG/E
- c) DMC-TZ4EE
- d) DMC-TZ11GT
- e) DMC-TZ11GN
- f) DMC-TZ4PL, TZ11GC/GK/GJ

What is the difference is that the "INITIAL SETTINGS" data which is stored in Flash ROM mounted on Main PCB.

3.4.1. Defining methods

To define the model suffix to be serviced, refer to the nameplate which is putted on the bottom side of the Unit.

<p>a) DMC-TZ4P/PC The nameplate for these models show the following Safety registration mark.</p> 	
<p>b) DMC-TZ4EB/EF/EG/E The nameplate for these models show the following Safety registration mark.</p> 	
<p>c) DMC-TZ4EE The nameplate for this model show the following Safety registration mark.</p> 	
<p>d) DMC-TZ11GT The nameplate for this model show the following Safety registration mark.</p> 	
<p>e) DMC-TZ11GN The nameplate for this model show the following Safety registration mark.</p> 	
<p>f) DMC-TZ4PL, TZ11GC/GK/GJ The nameplate for these models do not show any above safety registration mark.</p>	

NOTE:

After replacing the MAIN PCB, be sure to achieve adjustment.

The adjustment instruction is available at "software download" on the "Support Information from NDBG/VDBG-PAVC" web-site in "TSN system", together with Maintenance software.

3.4.2. INITIAL SETTINGS:

When you replace the Main PCB, be sure to perform the initial settings after achieving the adjustment by ordering the following procedure in accordance with model suffix of the unit.

1. IMPORTANT NOTICE:

Before proceeding Initial settings, be sure to read the following CAUTIONS.

CAUTION 1 (Initial Settings)

DO NOT select "NONE(JAPAN)" or "P"(North America) if need to select "EG/E/PL/GD/GC/SG/GT/GK/EF/EB/EE/GN/PR/GJ and PC".

Otherwise, once "NONE(JAPAN)" or "P"(North America) are selected, "EG/E/PL/GD/GC/SG/GT/GK/EF/EB/EE/GN/PR/GJ and PC" will not displayed, thus, RE-Settings (changing area) can not be made.

CAUTION 2 (Picture back up from "Built-in Memory")

This unit "Built-in Memory" for picture image data recording. (Approx. 50MB)
Be sure make picture data back up (i.e., Copying to SD memory card), before proceeding "INITIAL SETTING".

Once "INITIAL SETTING" has been carried out, all image data stored at "Built-in Memory" is erased.

2. PROCEDURES:

- Preparation. Proceed the picture back up from the unit (Refer to above "CAUTION 2")
- **Step 1. The temporary cancellation of initial setting:**
Set the REC/PLAY switch to "[Recording]".
Set the mode dial to "[Normal picture mode] (Red camera mark)".
While keep pressing [E. zoom switch] and "[UP] of Cross Key" simultaneously, turn the Power on.
- **Step 2. The cancellation of initial setting:**
Set the REC/PLAY switch to "[Playback]".
Press [E. zoom switch] and "[UP] of Cross Key" simultaneously, then turn the Power off.
- **Step 3. Turn the Power on:**
Set the REC/PLAY switch to "[Recording]".
Set the mode dial to "[Normal picture mode] (Red camera mark)", and then turn the Power on.
- **Step 4. Display the INITIAL SETTING:**
While keep pressing [MENU] and "[RIGHT] of Cross Key" simultaneously, turn the Power off.

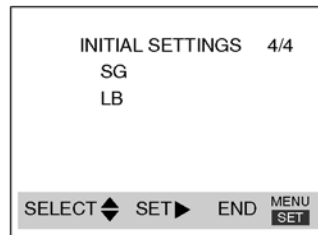
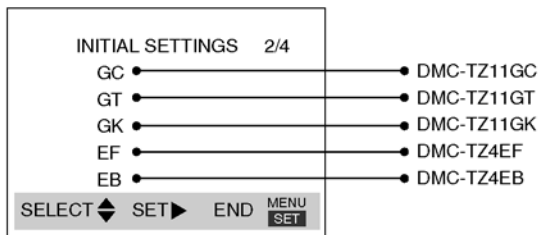
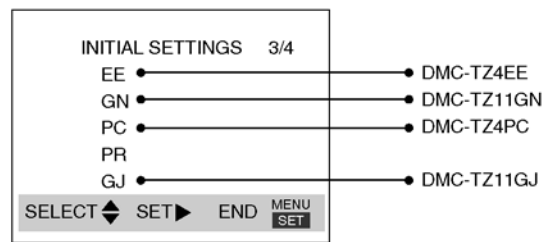
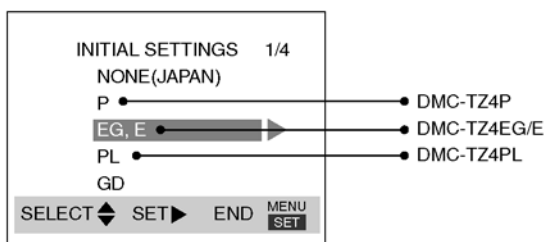

• **Step 5. Set the INITIAL SETTING: (Refer to “CAUTION 1”)**

[Caution for before settings]

Once "NONE(JAPAN)" (Area for Japan) or "P" (Area for North America) is selected with "INITIAL SETTINGS", other areas will not displayed even if "INITIAL SETTINGS" menu is displayed again, thus, the area can not be changed.

Select the area carefully.

Select the area with pressing “[UP]/[DOWN] of Cross Key”, and then press the “[RIGHT] of Cross Key”.

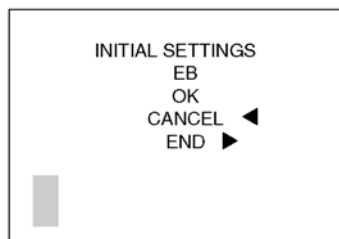

The only set area is displayed, and then press the “[RIGHT] of Cross key” after confirmation.

(The unit is powered off automatically.)

Confirm the display of “PLEASE SET THE CLOCK” in English when the unit is turned on again.

• **Step 6. CONFIRMATION:**

The display shows “PLEASE SET THE CLOCK” when turn the Power on again.

When the unit is connected to PC with USB cable, it is detected as removable media.

(When the “GT” or “GK” model suffix is selected, the display shows “PLEASE SET THE CLOCK” in Chinese.)

1) As for your reference Default setting condition is given in the following table.

• **Default setting (After “INITIAL SETTINGS”)**

	MODEL	VIDEO OUTPUT	LANGUAGE	DATE	REMARKS
a)	DMC-TZ4P/PC/PL	NTSC	English	Month/Date/Year	
b)	DMC-TZ4EB/EG/E/ DMC-TZ11GC/GN/GJ	PAL	English	Date/Month/Year	
c)	DMC-TZ4EF	PAL	French	Date/Month/Year	
d)	DMC-TZ4EE	PAL	Russian	Date/Month/Year	
e)	DMC-TZ11GK	PAL	Chinese (simplified)	Year/Month/Date	
f)	DMC-TZ11GT	NTSC	Chinese (traditional)	Year/Month/Date	

4 Specifications

Power Source	DC 5.1 V
Power Consumption	When recording: 1.2 W When playing back: 0.6 W
Camera effective pixels	8,100,000 pixels
Image sensor	1/2.5" CCD, total pixel number 8,320,000 pixels Primary color filter
Lens	Optical 10 x zoom f=4.7 mm to 47 mm (35 mm film camera equivalent: 28 mm to 280 mm)/F3.3 to F4.9
Digital zoom	Max.4 x
Extended optical zoom	Max. 15.9 x
Focus	Normal/Macro Face detection/9-area-focusing/3-area-focusing (High speed)/ 1-area-focusing (High speed)/1-area-focusing/Spot-focusing
Focus range	
Normal/Motion picture	50 cm (1.64 feet) (Wide)/2 m (6.57 feet) (Tele) to ∞
Macro/Intelligent Auto/ Clipboard	5 cm (0.17 feet) (Wide)/1 m (3.28 feet) (Tele) to ∞ (2 m (6.57 feet) unless max.T)
Scene mode	There may be difference in above settings.
Shutter system	Electronic shutter + Mechanical shutter
Motion picture recording	848 × 480 pixels* /640 × 480 pixels* /320 × 240 pixels (* Only when using an SD Memory Card) 30, or 10 frames/second with audio.
Burst recording	
Burst speed	3 pictures/second (Burst), Approx. 2 pictures/second (Unlimited)
Number of recordable pictures	Max. 7 pictures (Standard), max. 4 pictures (Fine), Depends on the remaining capacity of the built-in memory or the card (Unlimited).
Hi-speed burst	
Burst speed	Approx. 7 pictures/second
Number of recordable pictures	Approx. 20 pictures (When using the built-in memory, immediately after formatting) Max. 100 pictures (When using a card, differs depending on the type of card and the recording conditions)
ISO sensitivity	AUTO/100/200/400/800/1600 [HIGH SENS.] mode: 1600 - 6400
Shutter speed	8 to 1/2000th [STARRY SKY] mode: 15 seconds, 30 seconds, 60 seconds
White balance	AUTO/Daylight/Cloudy/Shade/Halogen/White set
Exposure (AE)	AUTO (Program AE) Exposure compensation (1/3 EV Step, -2 EV to +2 EV)
Metering mode	Multiple/Center weighted/Spot
LCD monitor	2.5" amorphous silicon TFT LCD (Approx. 230,400 dots) (field of view ratio about 100 %)

Flash	Flash range: (ISO AUTO) Approx.60 cm (1.97 feet) to 5.3 m (17.4 feet) (Wide) AUTO, AUTO/Red-eye reduction, Forced flash ON (Forced flash ON/Red-eye reduction), Slow sync./Red-eye reduction, Forced flash OFF
Microphone	Monaural
Speaker	Monaural
Recording media	Built-in Memory (Approx. 50 MB)/SD Memory Card/SDHC Memory Card/MultiMediaCard (Still pictures only)
Picture size	
Still picture	When the aspect ratio setting is [4:3] 3264 × 2448 pixels / 2560 × 1920 pixels / 2048 × 1536 pixels / 1600 × 1200 pixels / 640 × 480 pixels
	When the aspect ratio setting is [3:2] 3264 × 2176 pixels / 2560 × 1712 pixels / 2048 × 1360 pixels
	When the aspect ratio setting is [16:9] 3264 × 1840 pixels / 2560 × 1440 pixels / 1920 × 1080 pixels
Motion pictures (* Only when using an SD Memory Card)	848 × 480 pixels* / 640 × 480 pixels* / 320 × 240 pixels
Quality	Fine/Standard
Recording file format	
Still Picture	JPEG (based on Design rule for Camera File system, based on Exif 2.21 standard)/DPOF corresponding
Still pictures with audio	JPEG (based on Design rule for Camera File system, based on Exif 2.21 standard) + QuickTime
Motion pictures	QuickTime Motion JPEG
Interface	Digital: USB 2.0 (High Speed) Analog video/audio: NTSC/PAL Composite (Switched by menu), Component/Audio line output (monaural)
Terminal	COMPONENT OUT: Dedicated jack (10 pin) DIGITAL/AV OUT: Dedicated jack (8 pin) DC IN: Dedicated jack (2 pin)
Dimensions (excluding the projection part)	Approx. 103.3 mm (W) × 59.3 mm (H) × 36.2 mm (D) [4.07" (W) × 2.33" (H) × 1.43" (D)]
Mass	Excluding card and battery: Approx. 208 g (7.3 oz) With card and battery: Approx. 234 g (8.3 oz)
Operating temperature	0 °C to 40 °C (32 °F to 104 °F)
Operating humidity	10 % to 80 %

Battery charger

(Panasonic DE-A45B): Information for your safety

Output	CHARGE 4.2 V === 0.8 A
Input	110 V to 240 V 50/60Hz, 0.2 A

Equipment mobility: Movable

Battery Pack (lithium-ion)

(Panasonic CGA-S007A): Information for your safety

Voltage/capacity	3.7 V 1000 mAh
-------------------------	----------------

5 Location of Controls and Components

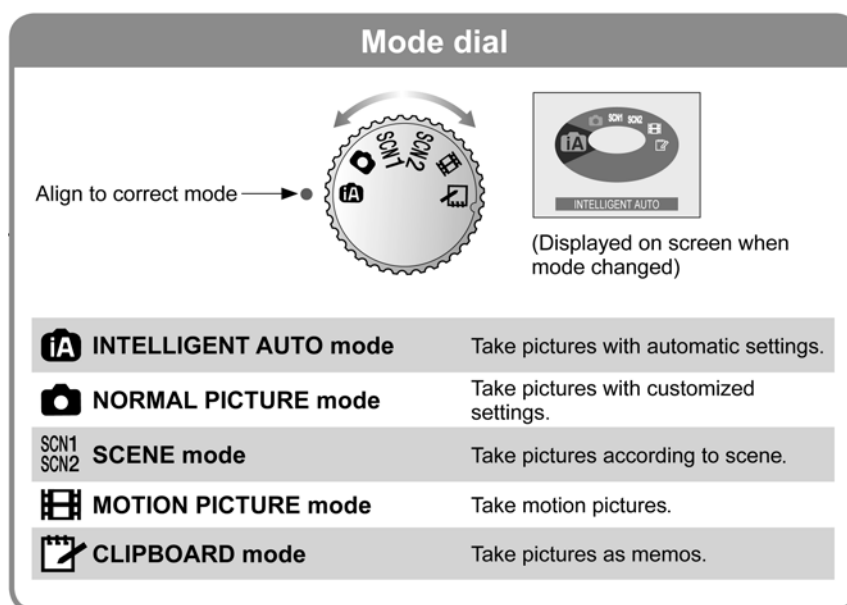
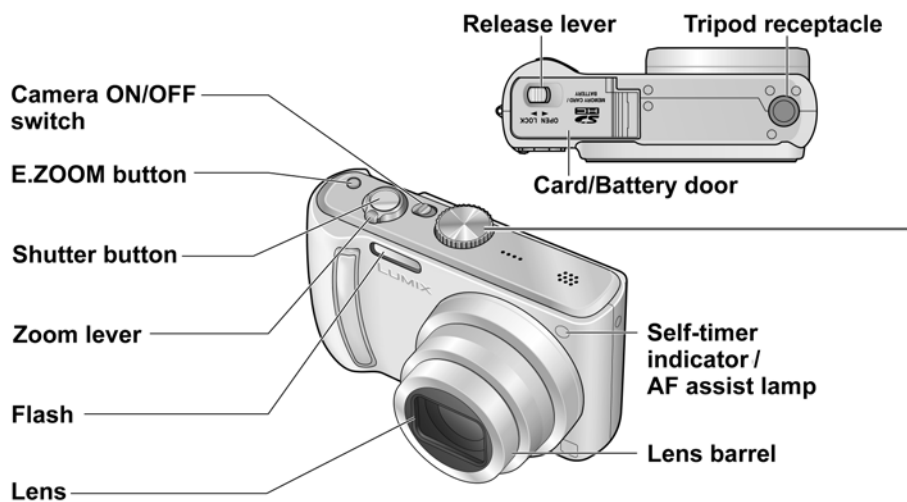

● This manual is based on the DMC-TZ5 model. Product illustrations and screens may vary.

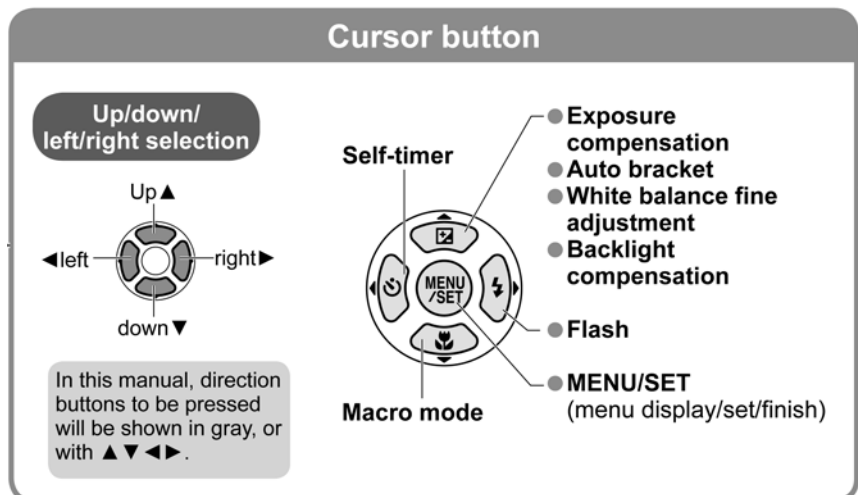
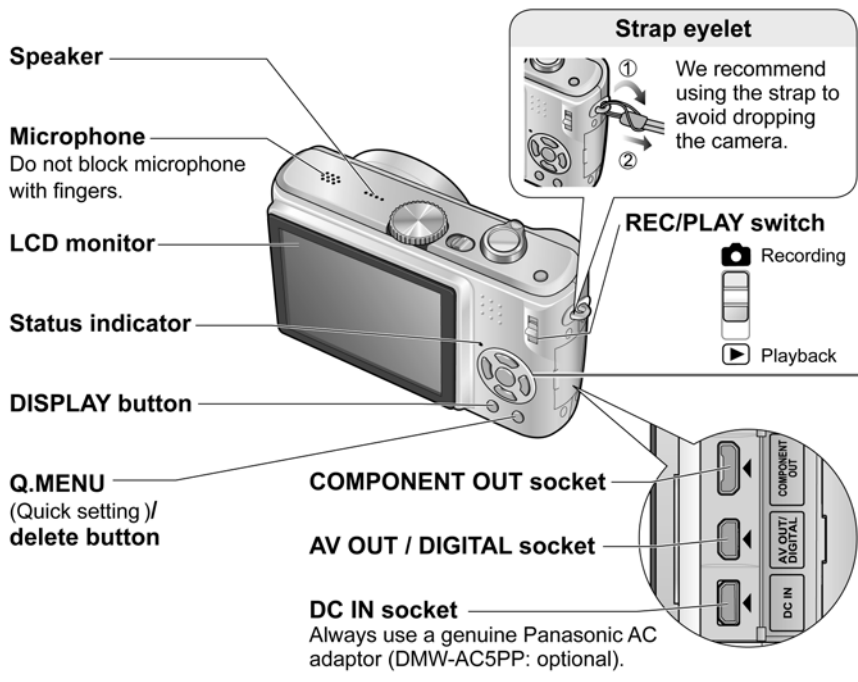

● This manual is based on the DMC-TZ5 model. Product illustrations and screens may vary.

6 Service Mode

6.1. Error Code Memory Function

1. General description

This unit is equipped with history of error code memory function, and can be memorized 16 error codes in sequence from the latest. When the error is occurred more than 16, the oldest error is overwritten in sequence.

The error code is not memorized when the power supply is shut down forcibly (when the unit is powered on by the battery, the battery is pulled out) because the error code is memorized to FLASH ROM when the unit is powered off.

2. How to display

The error code can be displayed by the following procedure:

Before perform the error code memory function, connect the AC adaptor or insert the battery.

(Since this unit has built-in memory, this error code memory function can be performed without inserting SD memory card.)

• 1. The temporary cancellation of initial setting:

Set the mode dial to "[Normal picture mode] (Red camera mark)".

While keep pressing [E. zoom switch] and "[UP] of Cross Key" simultaneously, turn the Power on.

• 2. The display of error code:

Press [E. zoom switch], [MENU] and "[LEFT] of Cross Key" simultaneously with the step 1 condition.

The display is changed as shown below when the above buttons is pressed simultaneously.

Normal display → Error code display → Operation history display → Normal display →

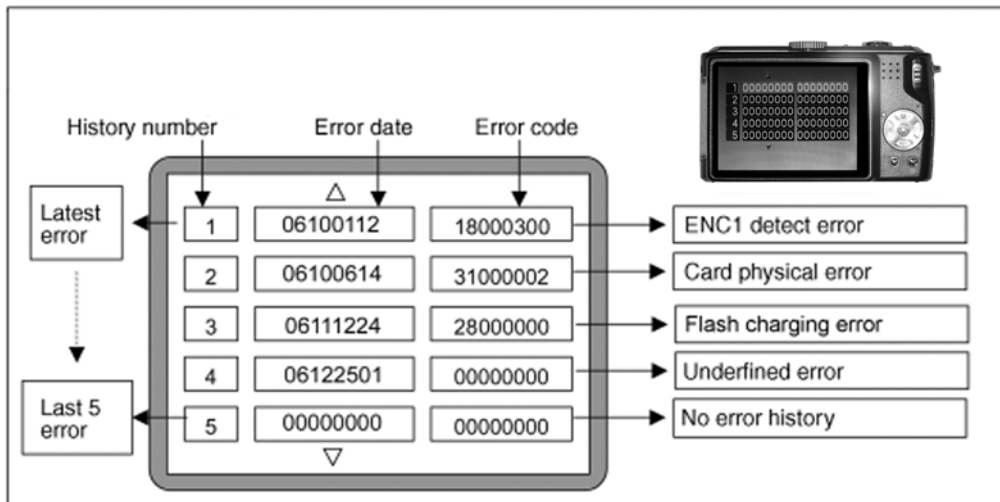

Example of Error Code Display

• 3. The change of display:

The error code can be memorized 16 error codes in sequence, however it is displayed 5 errors on the LCD.

Display can be changed by the following procedure:

"[UP] or [DOWN] of Cross Key" : It can be scroll up or down one by one.

"[LEFT] or [RIGHT] of Cross Key" : It can be scroll up or down every 5 error.

• 4. How to read the error date:

The error date code is displayed "year, month, day, time" in order.

(Example: "08030216" → 16 hours 2nd MAR. 2008)

Error date information is acquired from "Clock setting" setting, it is displayed as "00000000".

information when the error occurs. When the clock is not

• 5. How to read the error code:

One error code is displayed for 8 bit, the contents of error codes is indicated the table as shown below.

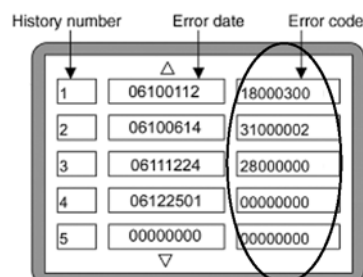

Attribute	Main item	Sub item	Error code		Contents (Upper)	
			High 4bits	Low 4 bits	Check point (Lower)	
LENS	Lens drive	OIS	18*0	1000	PSD (X) error. Hall element (X axis) position detect error in OIS unit. OIS Unit	
				2000	PSD (Y) error. Hall element (Y axis) position detect error in OIS unit. OIS Unit	
				3000	GYRO (X) error. Gyro (IC7101: X axis) detect error on Main P.C.B.. IC7101 (Gyro element) or IC6001 (VENUS 4)	
				4000	GYRO (Y) error. Gyro (IC7101: Y axis) detect error on Main P.C.B.. IC7101 (Gyro element) or IC6001 (VENUS 4)	
				5000	MREF error (Reference voltage error). IC9101 (LENS drive) or IC6001 (VENUS 4)	
				6000	Drive voltage (X) error. VENUS 4 AD value error, LENS Unit, LENS flex breaks etc.	
				7000	Drive voltage (Y) error. VENUS 4 AD value error, LENS Unit, LENS flex breaks etc.	
				C.B./Zoom	0010	HP Low detect error. (HP ENC. detects always low. (Fully retracted connection.)) Zoom motor, ABS ENC., and/or circuit failure. Zoom deadlock (Exit side).
					0020	HP Low detect error. (HP ENC. detects always high. (Exit connection.)) Zoom motor, ABS ENC., and/or circuit failure. Zoom deadlock (Retract side).
					0030	Zoom ENC. detect error. (No signal is supplied from Encoder located on
		0040	Zoom Motor.)			
		0050	Zoom motor, ABS ENC., and/or circuit failure Zoom deadlock.			
		Focus	0001		HP Low detect error (Focus encoder always Low detect error). FP9001-(33) signal line or IC6001 (VENUS 4)	
			0002	HP High detect error (Focus encoder always High detect error). FP9001-(41) signal line or IC6001 (VENUS 4)		
		Lens	18*1	0000	Power ON time out error. Lens drive system	
				18*2	0000	Power OFF time out error. Lens drive system
		Adj.History	OIS	19*0	2000	OIS adj. Yaw direction amplitude error (small)
					3000	OIS adj. Pitch direction amplitude error (small)
					4000	OIS adj. Yaw direction amplitude error (large)
					5000	OIS adj. Pitch direction amplitude error (large)
	6000				OIS adj. MREF error	
	7000				OIS adj. time out error	
	8000				OIS adj. Yaw direction off set error	
	9000				OIS adj. Pitch direction off set error	
	A000				OIS adj. Yaw direction gain error	
	B000				OIS adj. Pitch direction gain error	
C000	OIS adj. Yaw direction position sensor error					
D000	OIS adj. Pitch direction position sensor error					
E000	OIS adj. other error					
HARD	VENUS A/D	Flash	28*0	0000	Flash charging error. IC6001-(AC17) signal line or Flash charging circuit	
	FLASH ROM (EEPROM Area)	FLASH ROM (EEPROM Area)	2B*0	0001	EEPROM read error IC6002 (FLASH ROM)	
				0002	EEPROM write error IC6002 (FLASH ROM)	
	SYSTEM	RTC	2C*0	0001	SYSTEM IC initialize failure error Communication between IC6001 (VENUS 4) and IC9101 (SYSTEM)	

Attribute	Main item	Sub item	Error code		Contents (Upper)
			High 4bits	Low 4 bits	Check point (Lower)
SOFT	CPU	Reset	30*0	0001	NMI reset
				0007	Non Mask-able Interrupt (30000001-30000007 are caused by factors)
	Card	Card	31*0	0001	Card logic error SD memory card data line or IC6001 (VENUS 4)
				0002	Card physical error SD memory card data line or IC6001 (VENUS 4)
				0004	Write error SD memory card data line or IC6001 (VENUS 4)
				39*0	0005
	CPU, ASIC hard	Stop	38*0	0001	Camera task finish process time out. Communication between Lens system and IC6001 (VENUS 4)
				0002	Camera task invalid code error. IC6001 (VENUS 4)
				0100	File time out error in recording motion image IC6001 (VENUS 4)
				0200	File data send error in recording motion image IC6001 (VENUS 4)
				0300	Single or burst recording brake time out.
	Operation	Power on	3B*0	0000	FLASHROM processing early period of camera during movement.
	Zoom	Zoom	3C*0	0000	Imperfect zoom lens processing. Zoom lens
				35*0	0001 0007
			35*1	0000	Though record preprocessing is necessary, it is not called.
			35*2	0000	Though record preprocessing is necessary, it is not completed.

About “*” indication in the above table:

The third digit from the left is different as follows.

- In case of 0 (example: 18001000)

When the third digit from the left shows "0", this error occurred under the condition of INITIAL SETTINGS has been completed.

It means that this error is occurred basically at user side.

- In case of 8 (example: 18801000)

When the third digit from the left shows "8", this error occurred under the condition of INITIAL SETTINGS has been released.

(Example; Factory assembling-line before unit shipment, Service mode etc.)

It means that this error is occurred at service side.

• 6. How to returned to Normal Display:

Turn the power off and on, to exit from Error code display mode.



NOTE:

The error code can not be initialized.

7 Service Fixture & Tools

7.1. Service Fixture and Tools

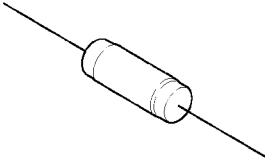
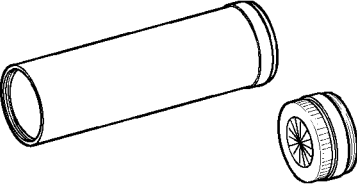
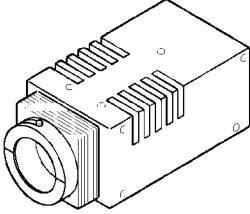
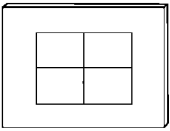
The following Service Fixture and tools are used for checking and servicing this unit.

Resistor for Discharging ERG5SJ102	Infinity Lens (Built-in Focus Chart) VFK1164TCM02	LIGHT BOX VFK1164TDVLB
 <p>An equivalent type of Resistor may be used.</p>	 <p>※ RFKZ0422 can be used.</p>	 <p>※ with DC Cable</p>
TR Chart RFKZ0443	Lens Cleaning Kit (BK) VFK1900BK	Grease (for Lens) (for focus motor) RFKZ0472
	 <p>* Only supplied as 10 set/box.</p>	

7.2. When Replacing the Main PCB

After replacing the MAIN PCB, be sure to achieve adjustment.

The adjustment instruction is available at “software download” on the “Support Information from NWBG/VDBG-PAVC” web-site in “TSN system”, together with Maintenance software.

7.3. Service Position

This Service Position is used for checking and replacing parts. Use the following Extension cables for servicing.

No.	Parts No.	Connection	Form
1	RFKZ0416	FP9001 (MAIN) - LENS UNIT	41PIN 0.3 FFC
2	RFKZ0363	FP9002 (MAIN) - TOP OPERATION UNIT	19PIN 0.5 FFC
3	RFKZ0354	FP9003 (MAIN) - LCD UNIT	37PIN 0.3 FFC
4	RFKZ0445	PP9001 (MAIN) - PS9801 (SUB)	100PIN B to B
5	VFK1951	FP9801 (SUB) - CCD UNIT	39PIN 0.3 FFC
6	VFK1175	FP9802 (SUB) - FP8001 (FLASH)	16PIN 0.5 FFC
7	VFK1974	FP9006 (MAIN) - LCD UNIT	4PIN 0.5 FFC

7.3.1. Extension Cable Connections

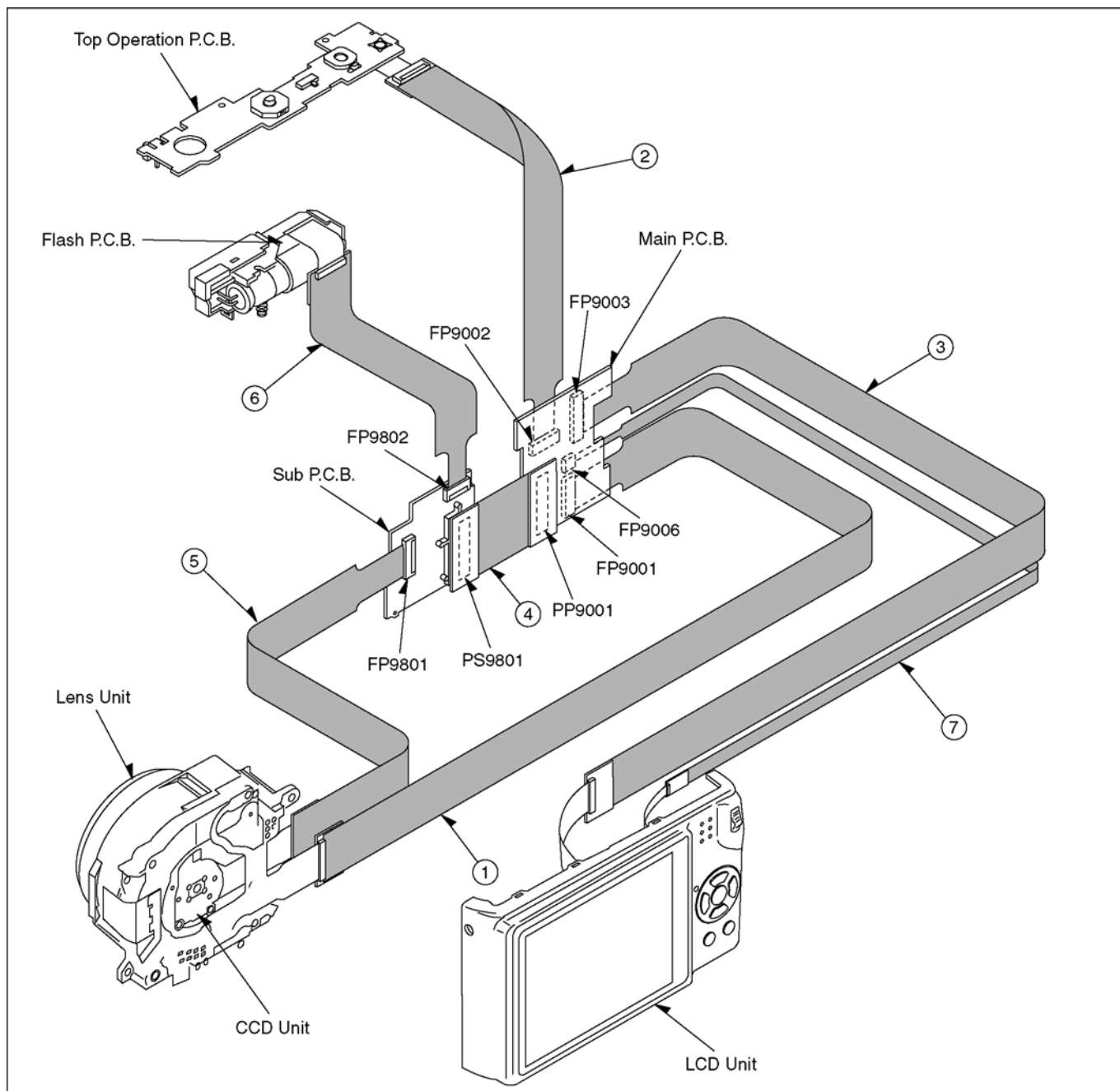

CAUTION-1. (When servicing FLASH PCB)

1. Be sure to discharge the capacitor on FLASH PCB.
Refer to "HOW TO DISCHARGE THE CAPACITOR ON FLASH PCB".
The capacitor voltage is not lowered soon even if the AC Cord is unplugged or the battery is removed.
2. Be careful of the high voltage circuit on FLASH PCB.
3. DO NOT allow other parts to touch the high voltage circuit on FLASH PCB.

8 Disassembly and Assembly Instructions

8.1. Disassembly Flow Chart

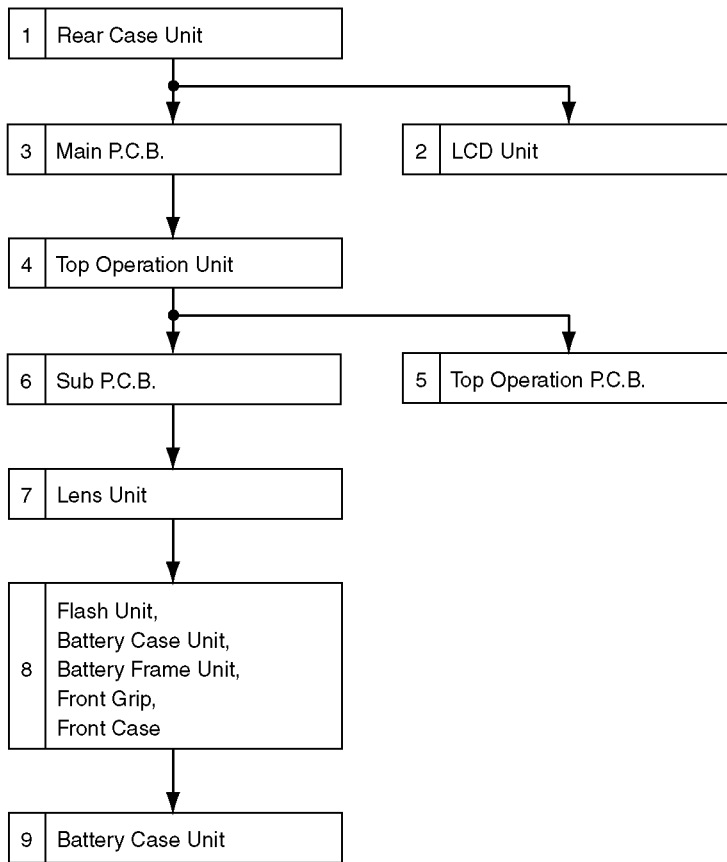

8.2. PCB Location

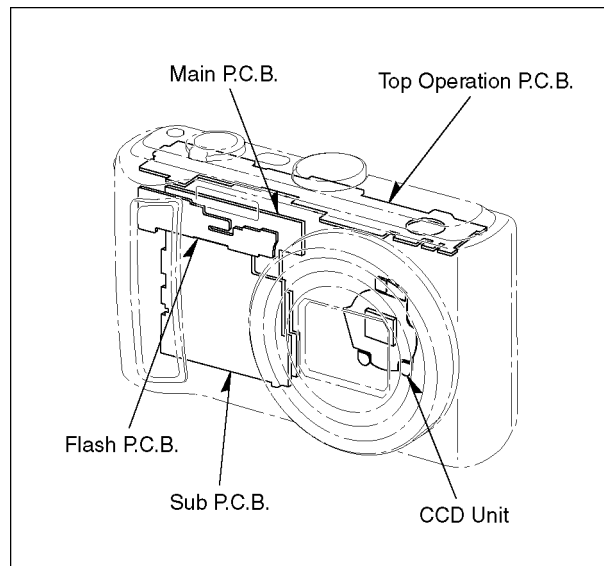

8.3. Disassembly Procedure

No.	Item	Fig.	Removal
1	Rear Case Unit	Fig.D1	Card
			Battery
			2 Screws (A)
			1 Screw (B)
			2 Screws (C)
			FP9003 (Flex)
			FP9006 (Flex)
			Insulation Sheet
			Rear Case Unit
2	LCD Unit	Fig.D2	5 Locking tabs LCD Unit
3	Main P.C.B. Unit,	Fig.D3	1 Locking tab
			Slide Guide
			Slide Knob
			FP9001 (Flex)
			FP9002 (Flex)
			PP9001 (Connector)
			Main P.C.B.
			PCB Spacer
4	Top Operation Unit	Fig.D4	Top Operation Unit
5	Top Operation P.C.B.	Fig.D5	2 Locking tabs
			AF Panel Light
			FP9902 (Flex)
			2 Screws (D)
			3 Locking tabs
			Top Operation P.C.B.
		Fig.D6	NOTE: (When Installing)
6	Sub P.C.B.	Fig.D7	1 Screw (E)
			PCB Plate
			FP9801 (Flex)
			FP9802 (Flex)
			2 Locking tabs
			Sub P.C.B.
7	Lens Unit	Fig.D8	2 Screws (F)
			1 Screw (G)
			Lens Unit
8	Flash Unit, Battery Case Unit, Battery Frame Unit, Front Grip, Front Case	Fig.D9	1 Screw (H)
			2 Screws (I)
			1 Screw (J)
			2 Screws (K)
		Fig.D10	2 Locking tabs
			Flash Unit
			Battery Case Unit
			Battery Frame Unit
			2 Locking tabs
			Front Grip
Front Case			
9	Battery Case Unit	Fig.D11	3 Locking tabs
			Battery Case Unit

8.3.1. Removal of the Rear Case Unit

NOTE:
When servicing and reassembling, remove the card and battery from the unit.

- Card
- Battery
- Screw(A) × 2
- Screw(B) × 1
- Screw(C) × 2
- FP9003 (Flex)
- FP9006 (Flex)

• When remove the insulation sheet, necessary removal the rear case unit.

NOTE: (When Replacing)

- Take care not to damage the flex.
- When remove the flex, pull up the locking tab in the direction of arrow (1), and then remove the flex in the direction of arrow (2).

Screw (A)	Screw (B)	Screw (C)
Ⓢ: SILVER Ⓚ: BLACK	Ⓢ: SILVER Ⓚ: BLACK	Ⓢ: SILVER Ⓚ: BLACK

Fig. D1

8.3.2. Removal of the LCD Unit

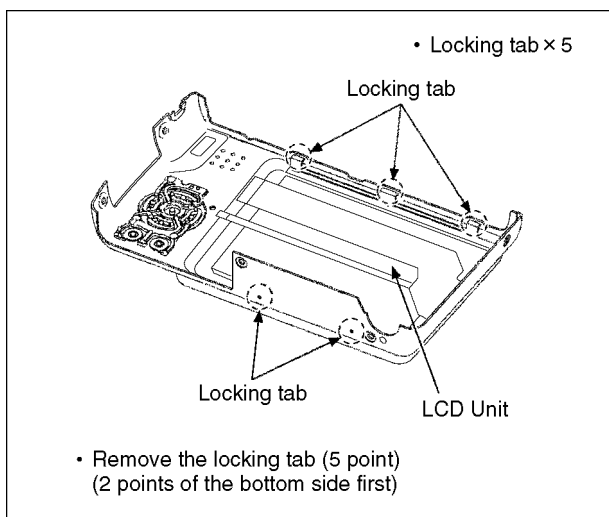

Fig. D2

8.3.3. Removal of the Main P.C.B.

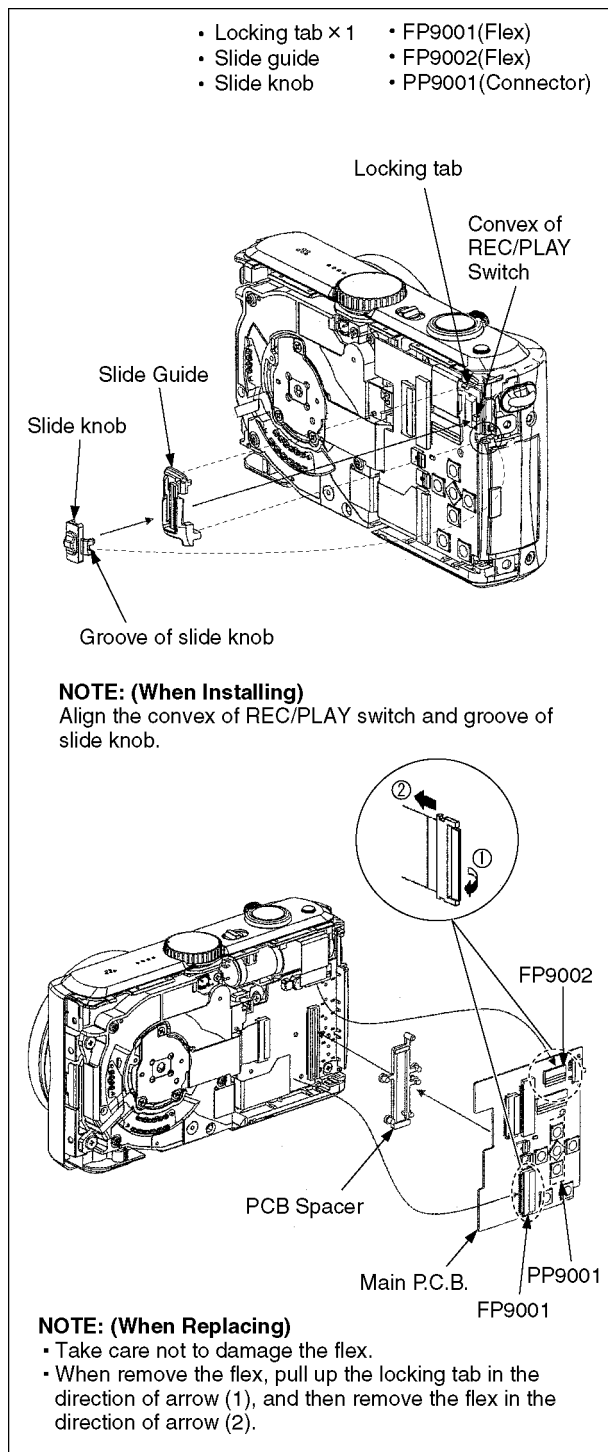

Fig. D3

8.3.4. Removal Top Operation Unit

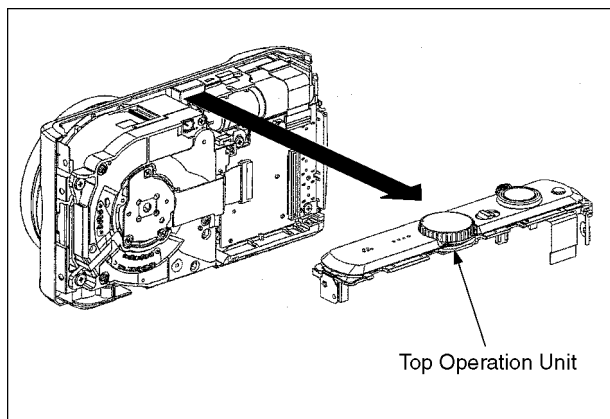

Fig. D4

8.3.5. Removal of the Top Operation P.C.B.

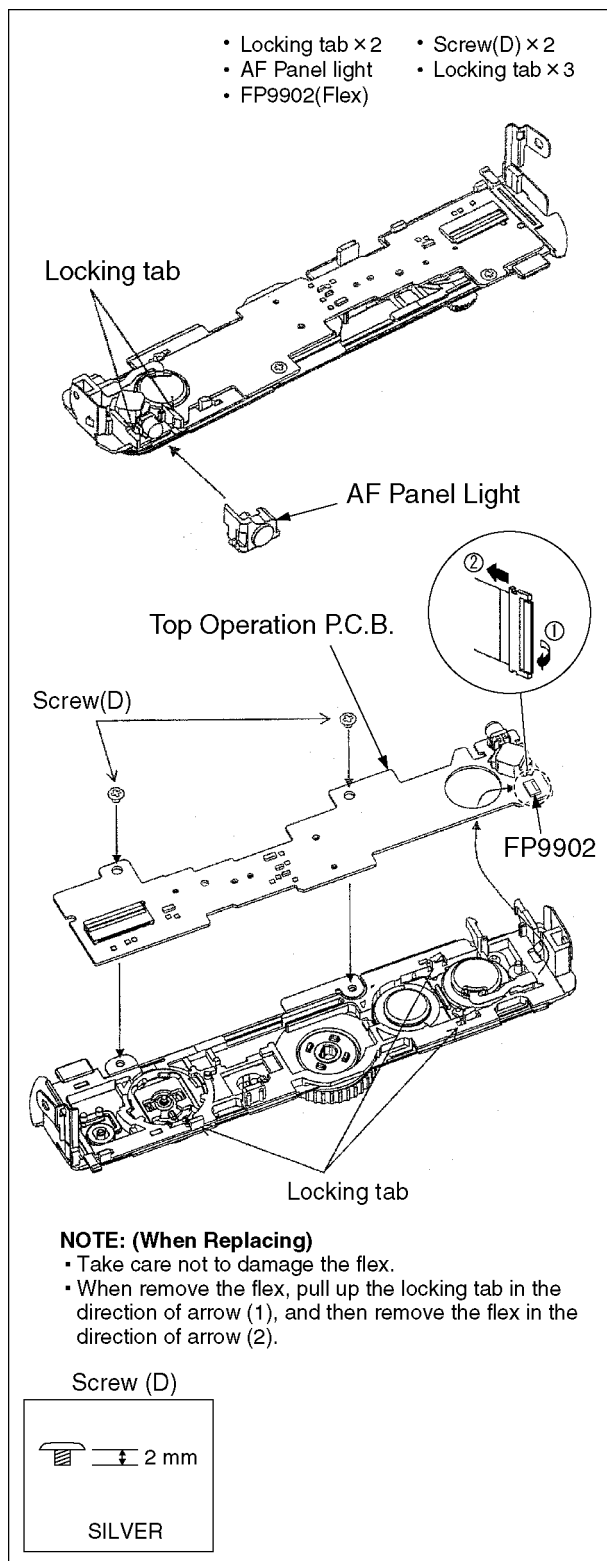

Fig. D5

NOTE: (When Installing)

Align the convex of power switch and groove power knob.
Align the convex of mode dial switch and groove of mode dial.
(Align the "D"cut part)

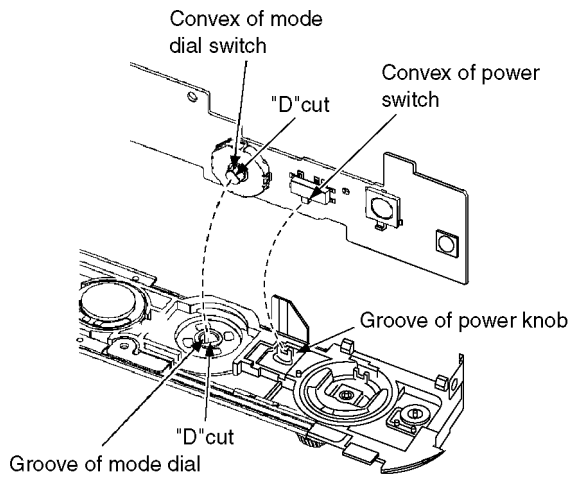
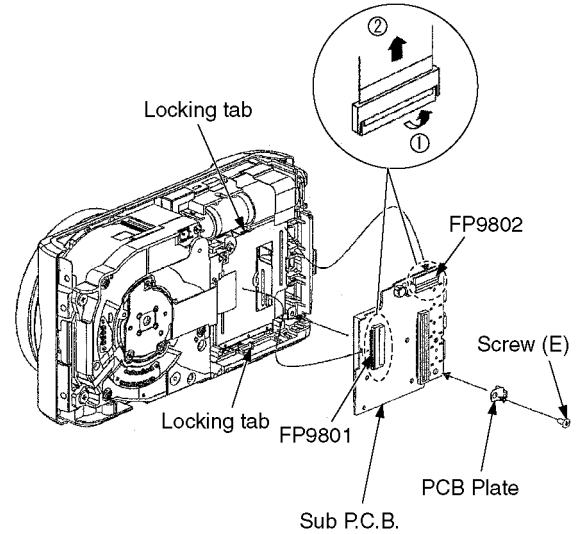

Fig. D6

8.3.6. Removal of the Sub P.C.B.

- Screw(E) × 1
- PCB Plate
- FP9801(Flex)
- FP9802(Flex)
- Locking tab × 1



NOTE: (When Replacing)

- Take care not to damage the flex.
- When remove the flex, pull up the locking tab in the direction of arrow (1), and then remove the flex in the direction of arrow (2).

Screw (E)



Fig. D7

8.3.7. Removal of the Lens Unit

- Screw(F) × 2
- Screw(G) × 1

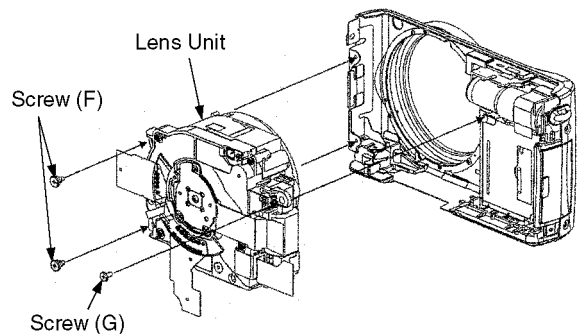

Screw (F)

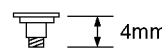

Screw (G)

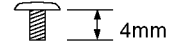

Fig. D8

8.3.8. Removal of the Flash Unit, Battery Case Unit, Battery Frame Unit, Front Grip and Front Case

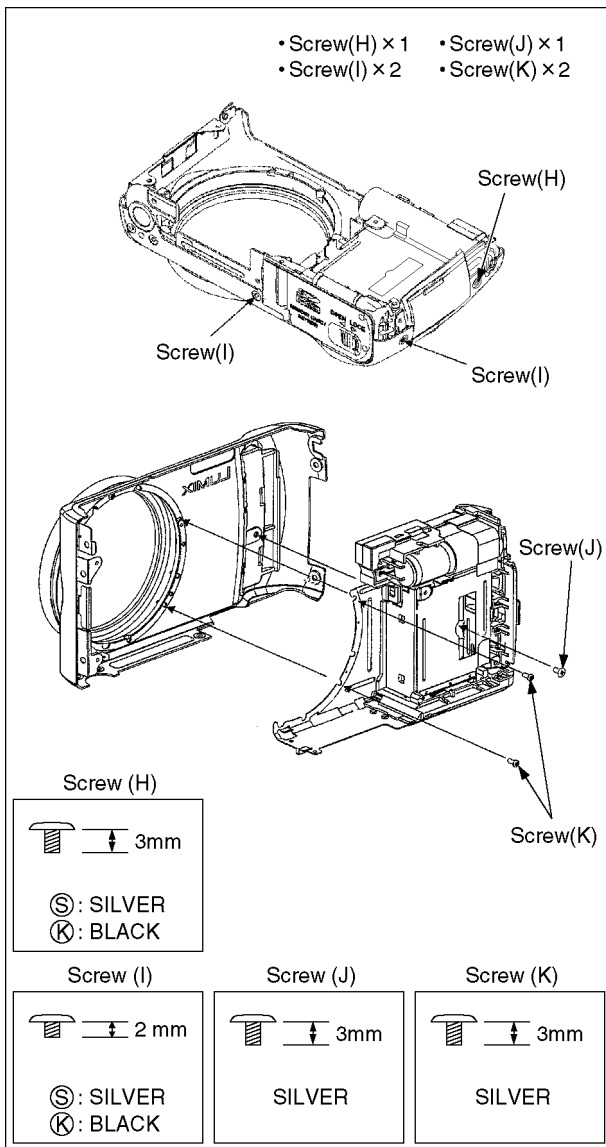

Fig. D9

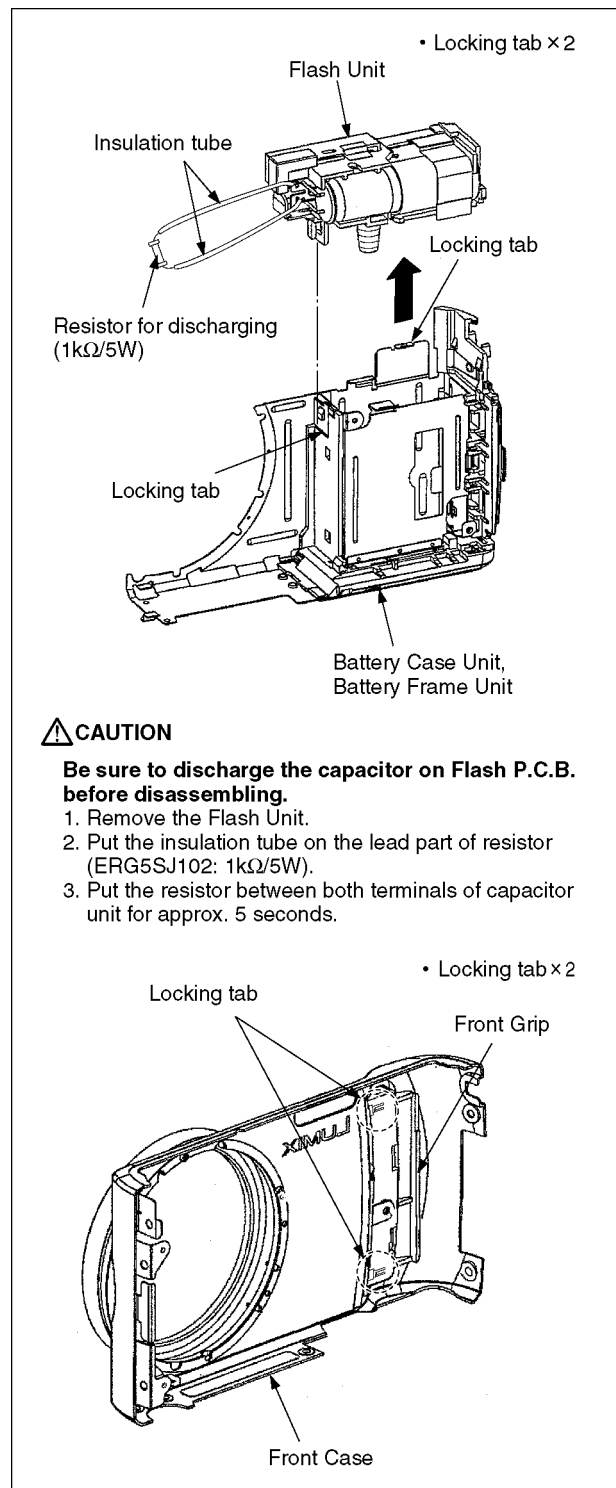

Fig. D10

8.3.9. Removal of the Battery Case Unit

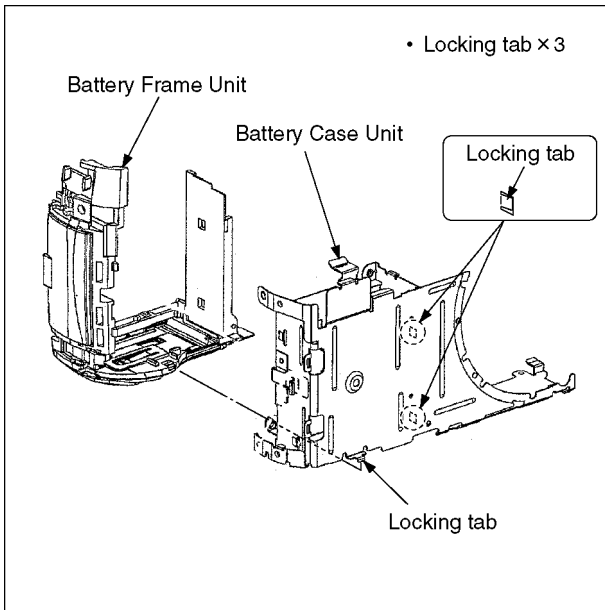

Fig. D11

NOTE: (When Assembling)

Be sure to confirm the following points when assembling.

- The Screw is tightened enough.
- Assembling conditions are fine. (No distortion, no illegal-space.)
- No dust and/or dirt on every Lens surfaces.
- LCD image is fine. (No dust and dirt on it, and no gradient images.)

8.4. Disassembly Procedure for the Lens

NOTE: When Disassembling and Assembling for the Lens

1. To minimize the possibility of the CCD being dirt, perform disassemble and/or assemble under the condition of the CCD is being mounted.
Disassembling procedures for the CCD unit, refer to item 8.6.
2. Take care that the dust and dirt are not entered into the lens.
In case of the dust is putted on the lens, blow off them by airbrush.
3. Do not touch the surface of lens.
4. Use lens cleaning KIT (BK)(VFK1900BK).
5. Apply the grease to the point where is shown to "Grease apply" in the figure.

8.4.1. Removal of the Zoom Motor Unit and Master Flange Unit

1. Unsolder (16 points).
2. Remove the libs (4 points).
3. Unscrew the 6 screws (A).
4. Remove the zoom motor unit.
5. Remove the master flange unit.

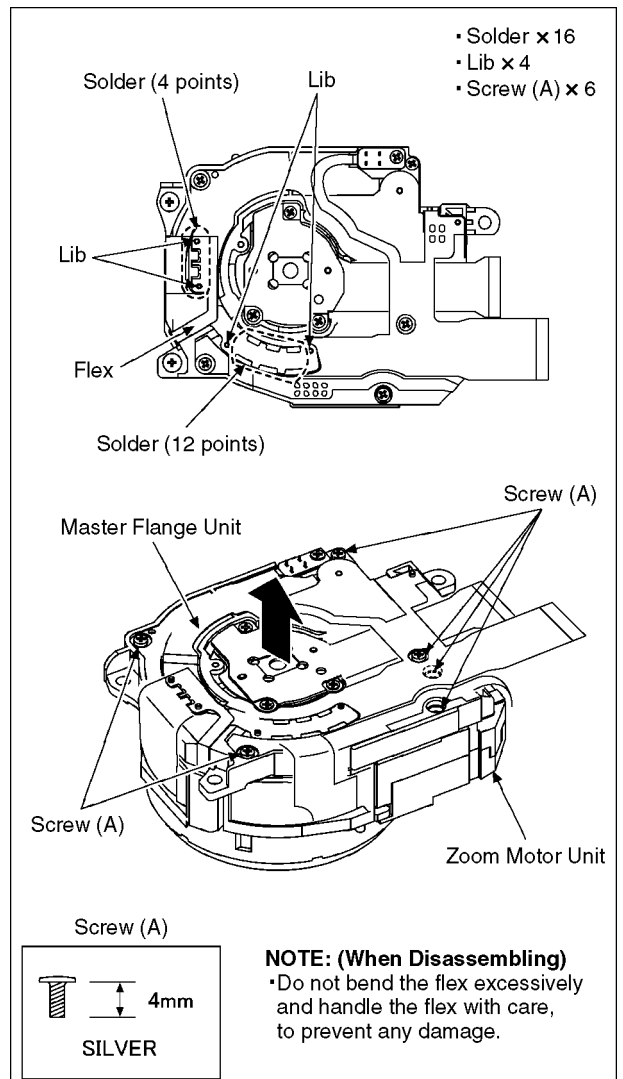

NOTE: (When Disassembling)

- Do not bend the flex excessively and handle the flex with care, to prevent any damage.

8.4.2. Removal of the Direct Frame, Both Side Cam, 1st Lens Frame/2nd Lens Frame/3rd Lens Frame, Penetration Cam and Drive Frame

- Push the penetration cam to the indicated by arrow from lens side, and then remove the unit of direct frame, both side cam, 1st lens frame/2nd lens frame/3rd lens frame, penetration cam and drive frame from the fixed frame unit.

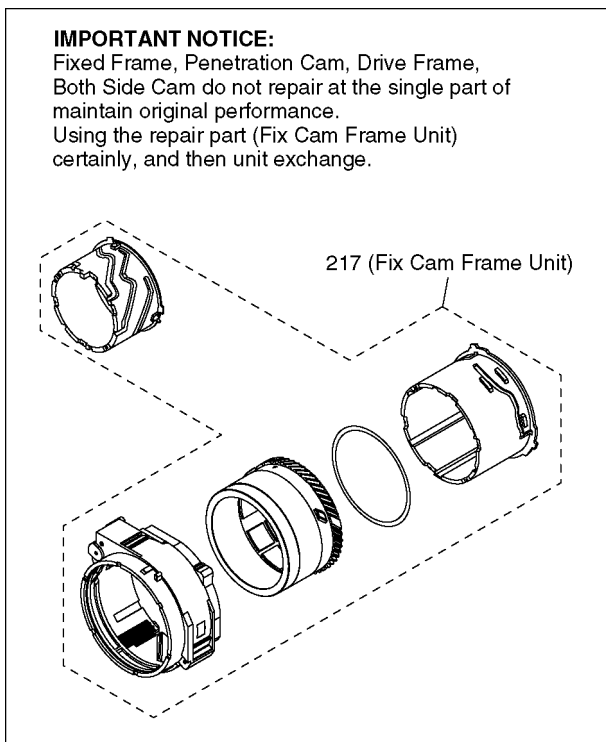
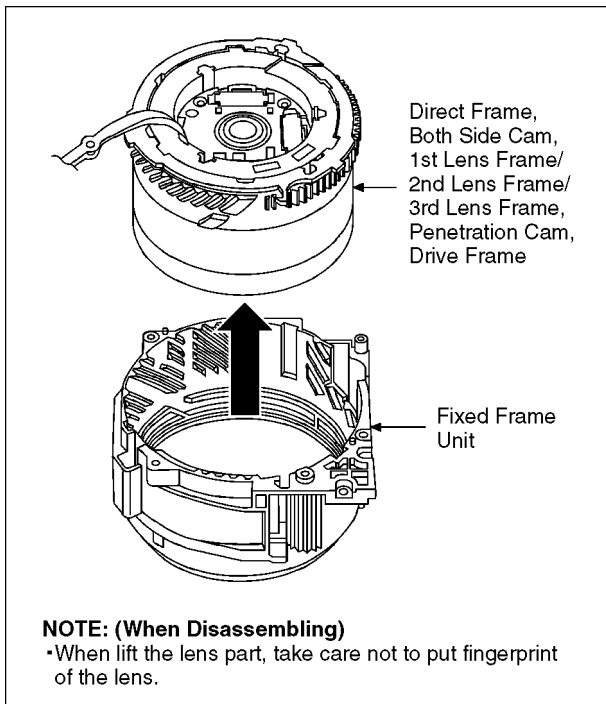

8.4.3. Removal of the Direct Frame, Both Side Cam and 1st Lens Frame/2nd Lens Frame/3rd Lens Frame

1. Turn the drive frame, and then Align the groove of drive frame and pin of 1st lens frame.

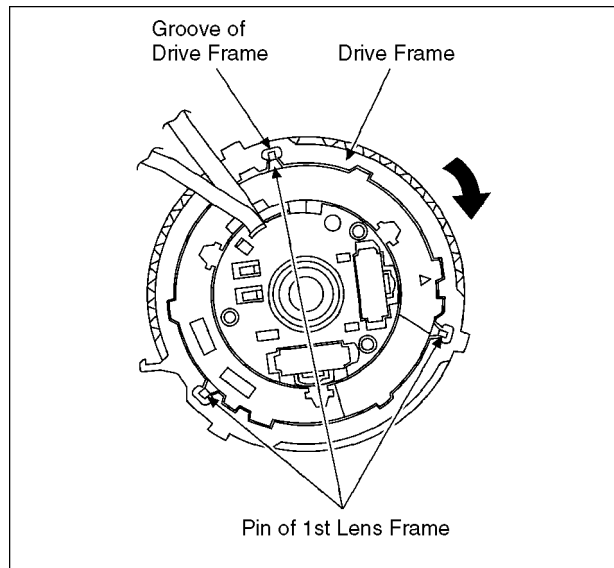

2. Push the 1st lens frame to the indicated by arrow from lens side, and then remove the unit of direct frame, both side cam and 1st lens frame/2nd lens frame/3rd lens frame from the penetration cam and drive frame.

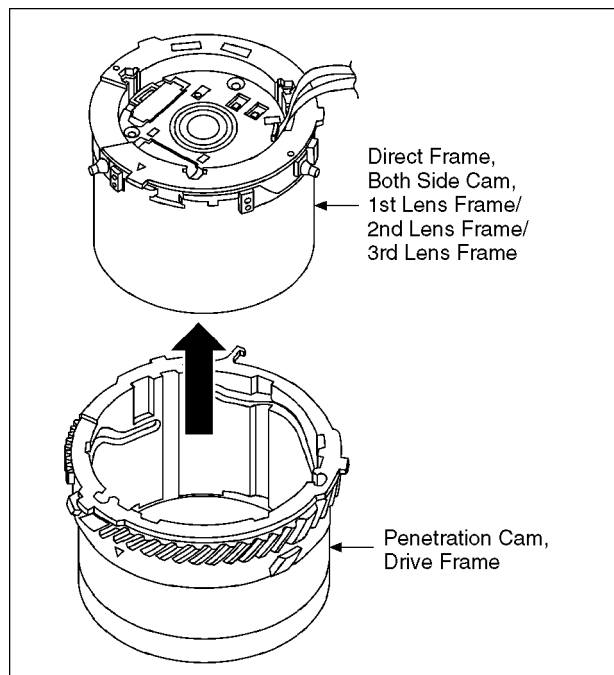

8.4.4. Removal of the Direct Frame, Both Side Cam and 2nd Lens Frame/3rd Lens Frame

- Turn to the indicated by arrow(1) while picking the pin, and then remove the unit of direct frame, both side cam and 2nd lens frame/3rd lens frame from the 1st lens frame.

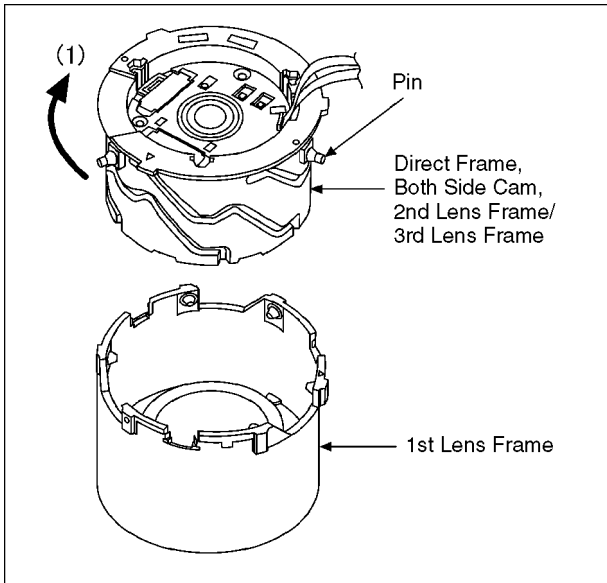

8.4.5. Removal of the 3rd Lens Frame and 2nd Lens Frame

1. Turn the direct frame, and then Align the groove of direct frame and groove of both side cam.
2. Remove the 3rd lens frame and 2nd lens frame from the direct frame, both side cam.

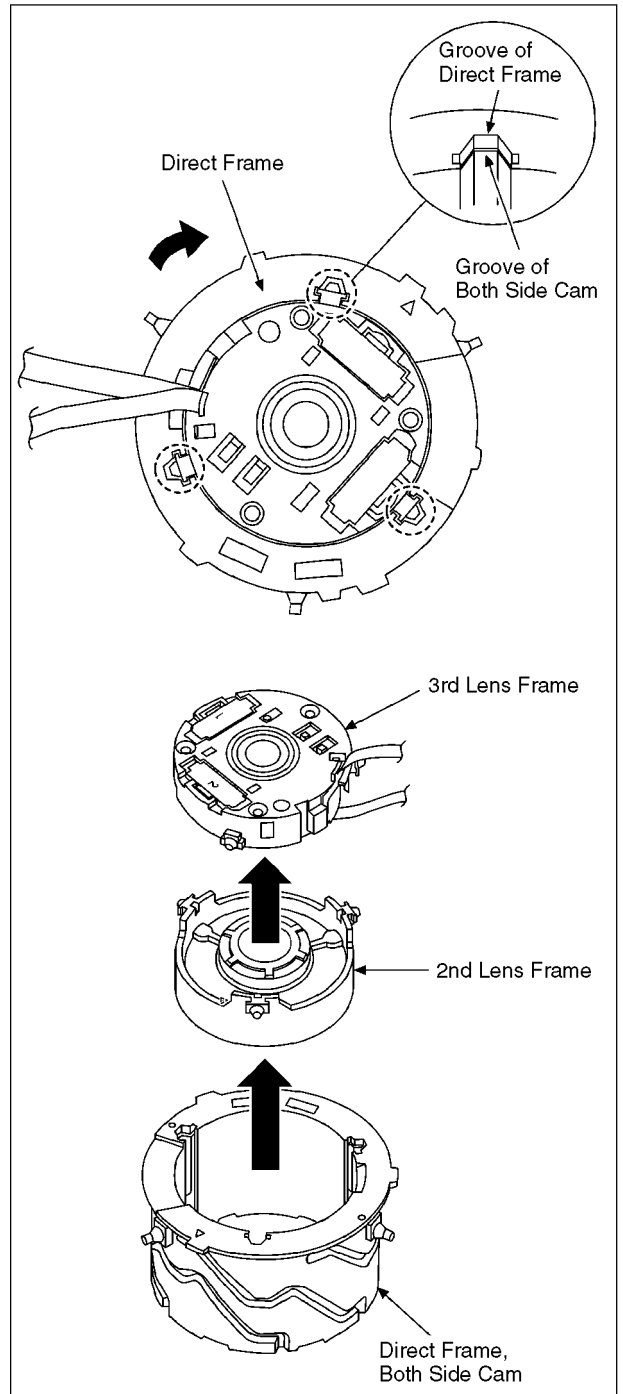

8.4.6. Removal of the Direct Frame

•Pull the direct frame to the indicated by arrow (1), and then turn to clockwise the direct frame in the indicated by arrow (2).

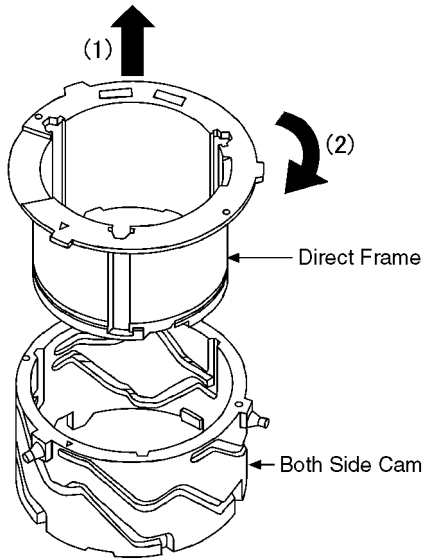

8.5. Assembly Procedure for Lens

8.5.1. Phase alignment of the Penetration Cam and Drive Frame

•Align the Δ mark, and then install the drive frame to penetration cam.

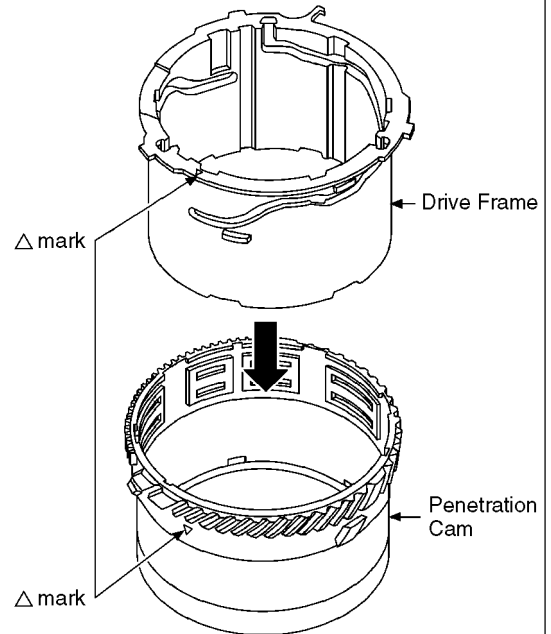

•Turn the Drive Frame in the direction of an arrow (about 5mm : 0.2 in.), and then align the phase so that three groove places to be aligned.

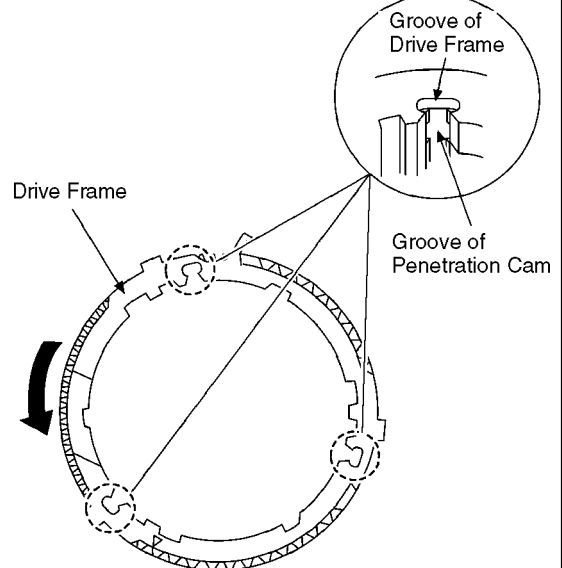

8.5.2. Phase alignment of the Direct Frame and Both Side Cam

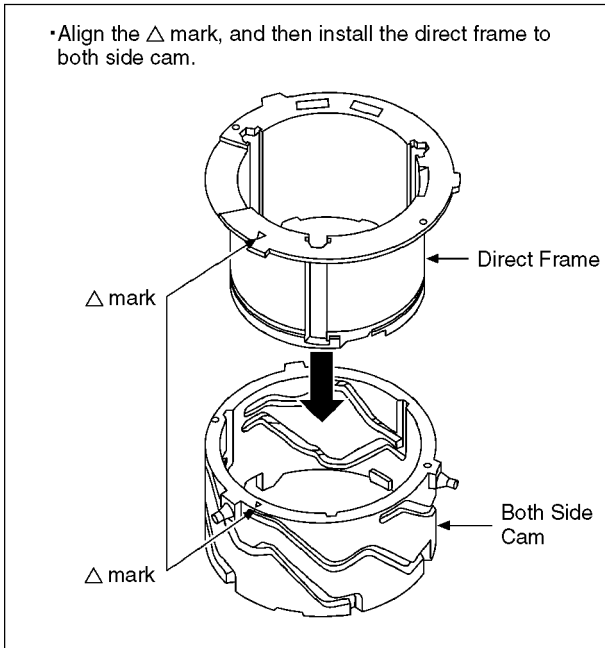

8.5.3. Assembly for the 2nd Lens Frame and 3rd Lens Frame

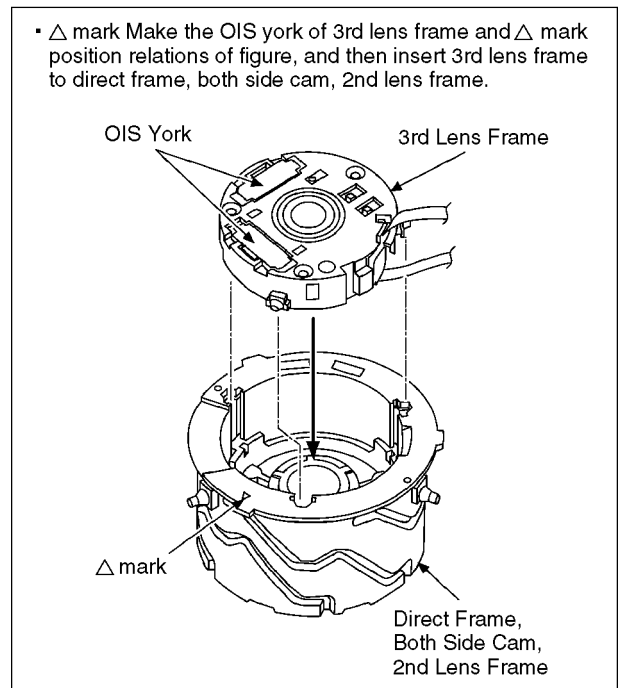
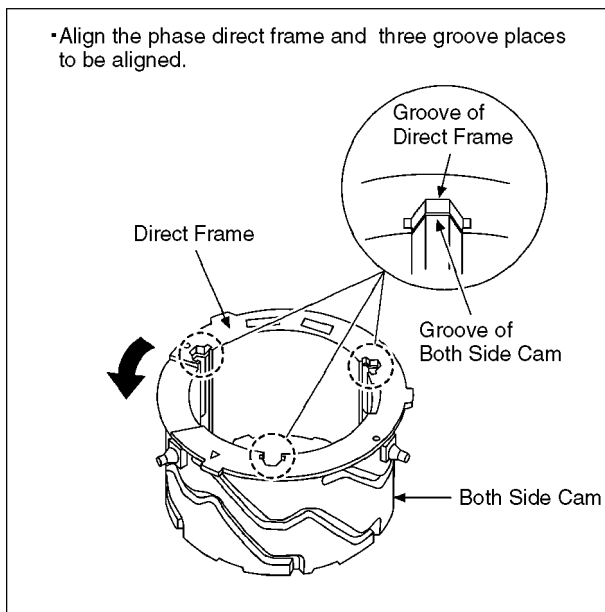
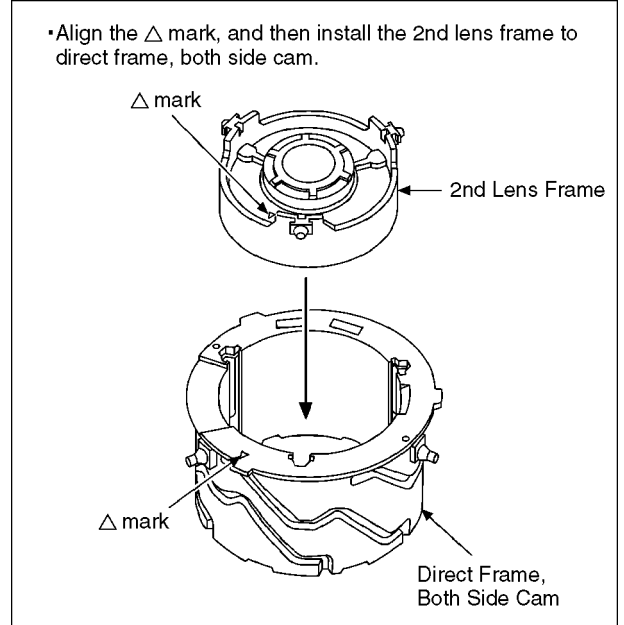

8.5.4. Assembly for the Direct Frame, Both Side Cam and 2nd Lens Frame/3rd Lens Frame

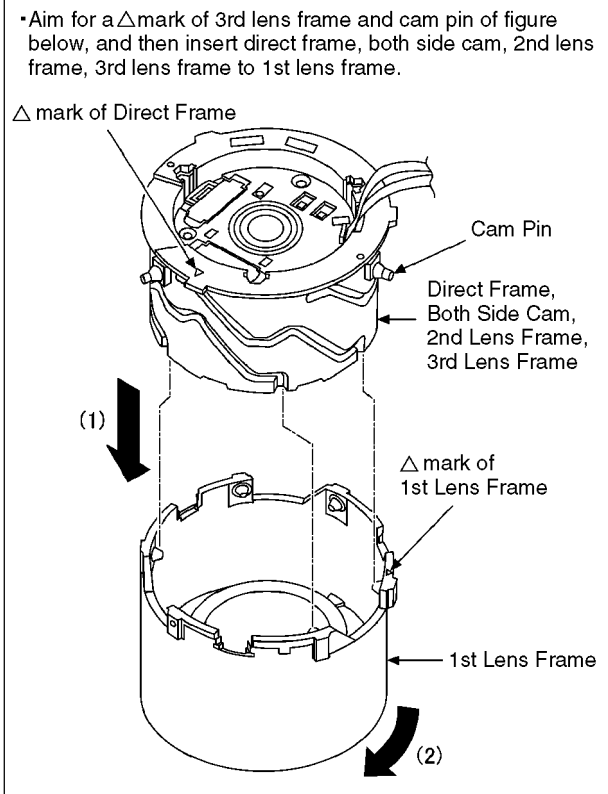

8.5.5. Assembly for the Direct Frame, Both Side Cam and 1st Lens Frame/ 2nd Lens Frame/3rd Lens Frame

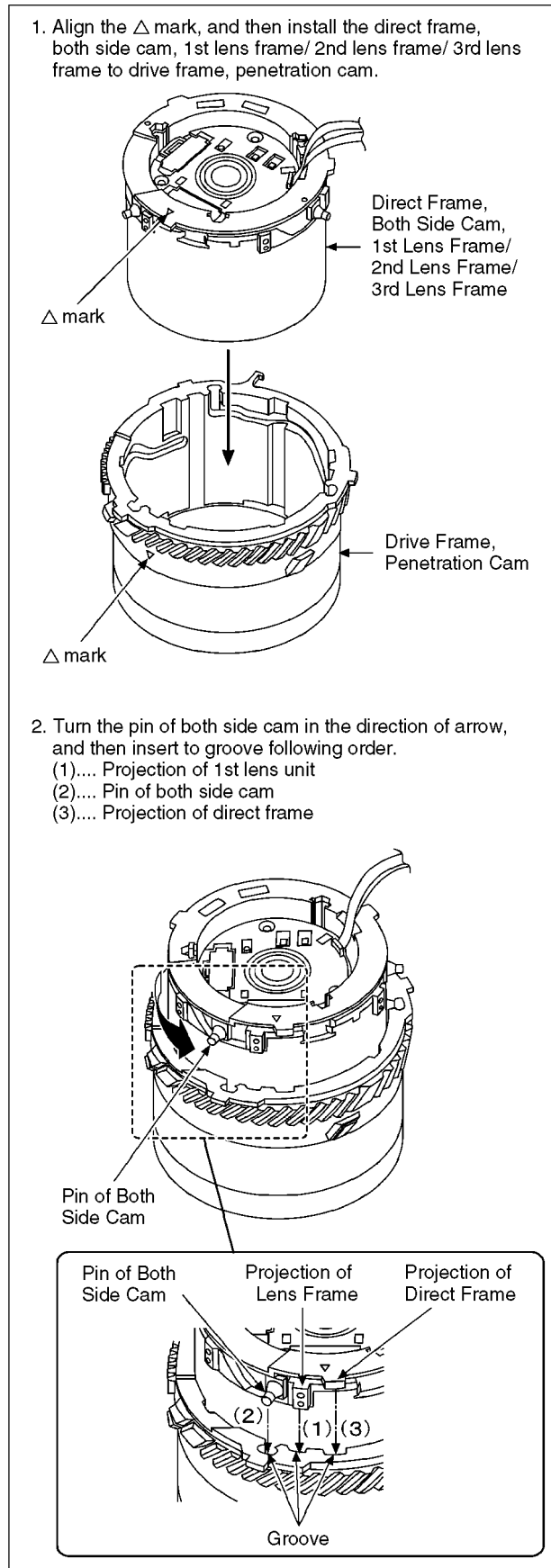

8.5.6. Assembly for the Direct Frame, Both Side Cam and 1st Lens Frame/ 2nd Lens Frame/3rd Lens Frame, Penetration Cam and Drive Frame

1. Align the Δ mark, and then install the direct frame, both side cam, 1st lens frame/ 2nd lens frame/ 3rd lens frame, penetration cam, drive frame of fixed frame.

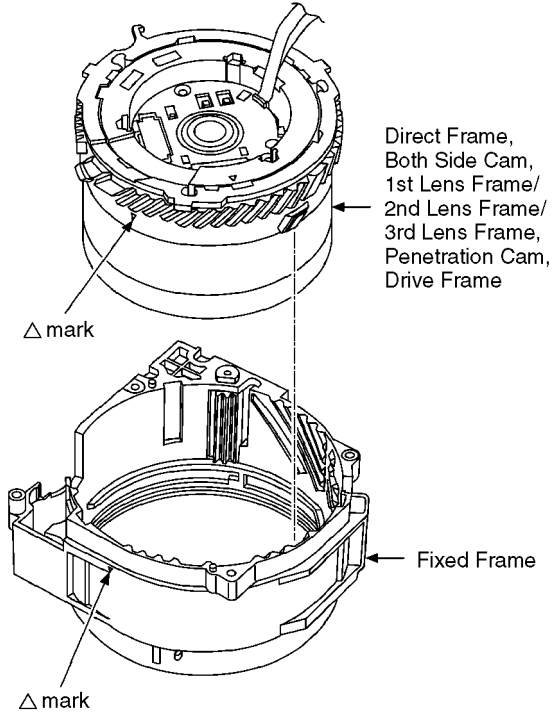

2. Turn the penetration cam in the direction of an arrow, and then put the hook to groove of fixed frame.

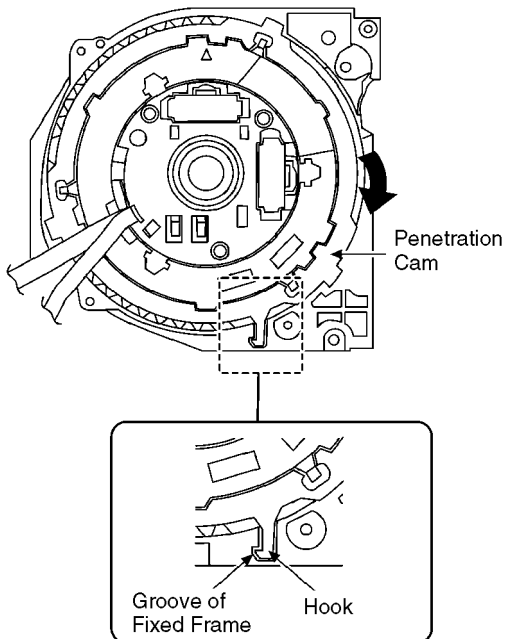

8.5.7. Assembly for the Zoom Motor Unit and Master Flange Unit

• Screw (A) x 6

NOTE: (When Installing)

- Refer to "THE APPLYMENT OF GREASE METHOD" when installing the master flange unit.
- Take care not to damage the flex.
- Insert the projection of master flange unit to hole of flex, and then insert to flex inserting part.

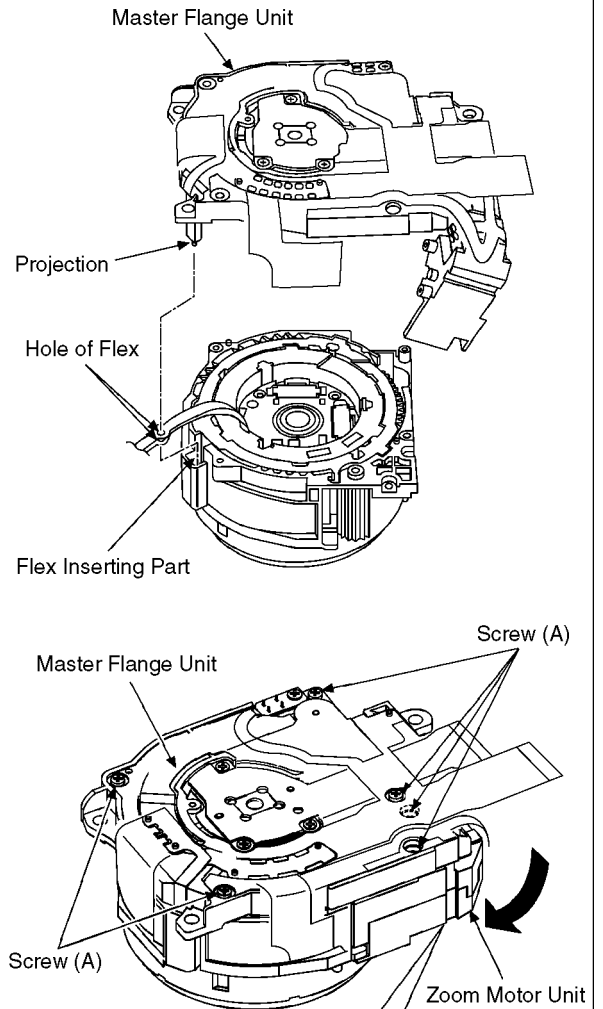

- Align the lib of fixed frame unit and hole of zoom motor unit, and then install them.

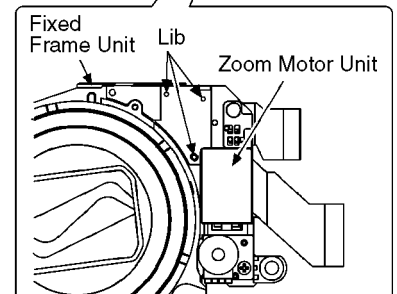

Screw (A)

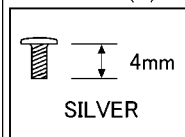

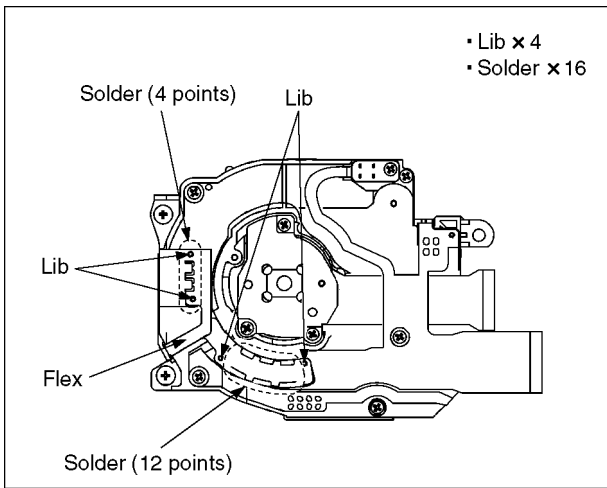

8.6. Removal of the CCD Unit

To prevent the CCD unit from catching the dust and dirt, do not remove the CCD unit except for replacing.

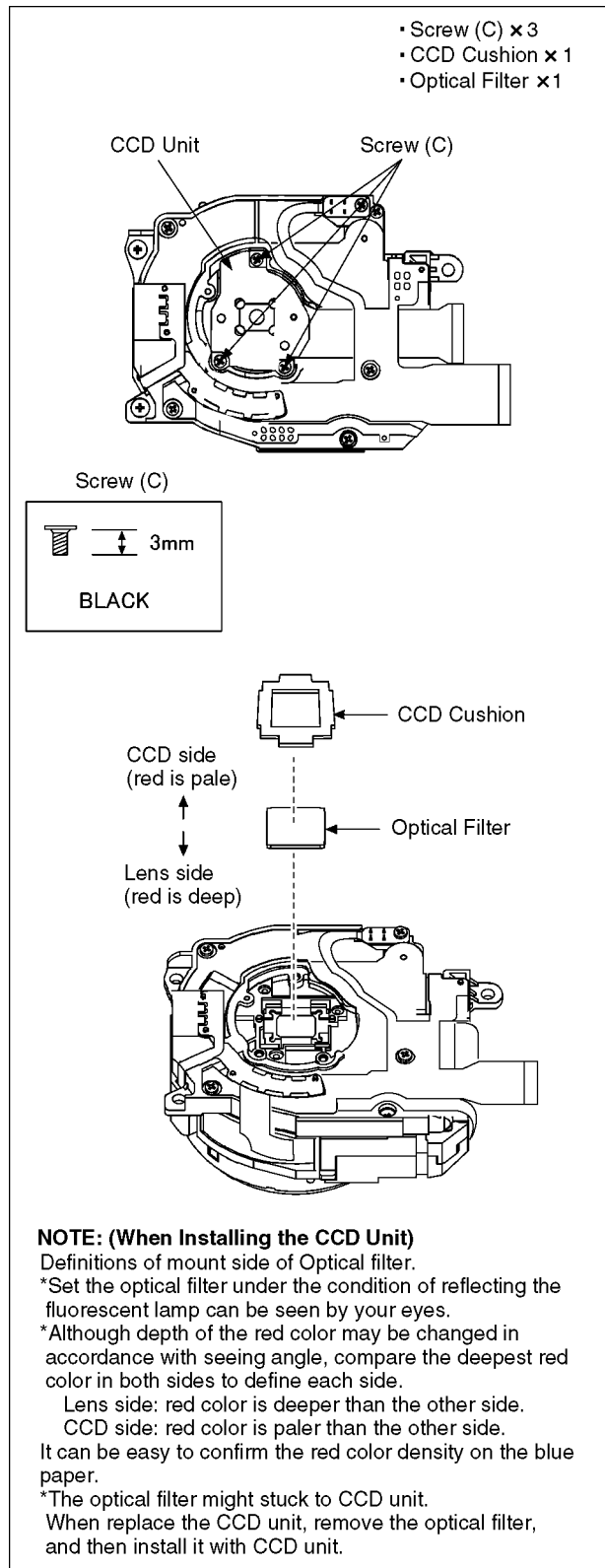

8.7. Removal of the Zoom Motor Unit

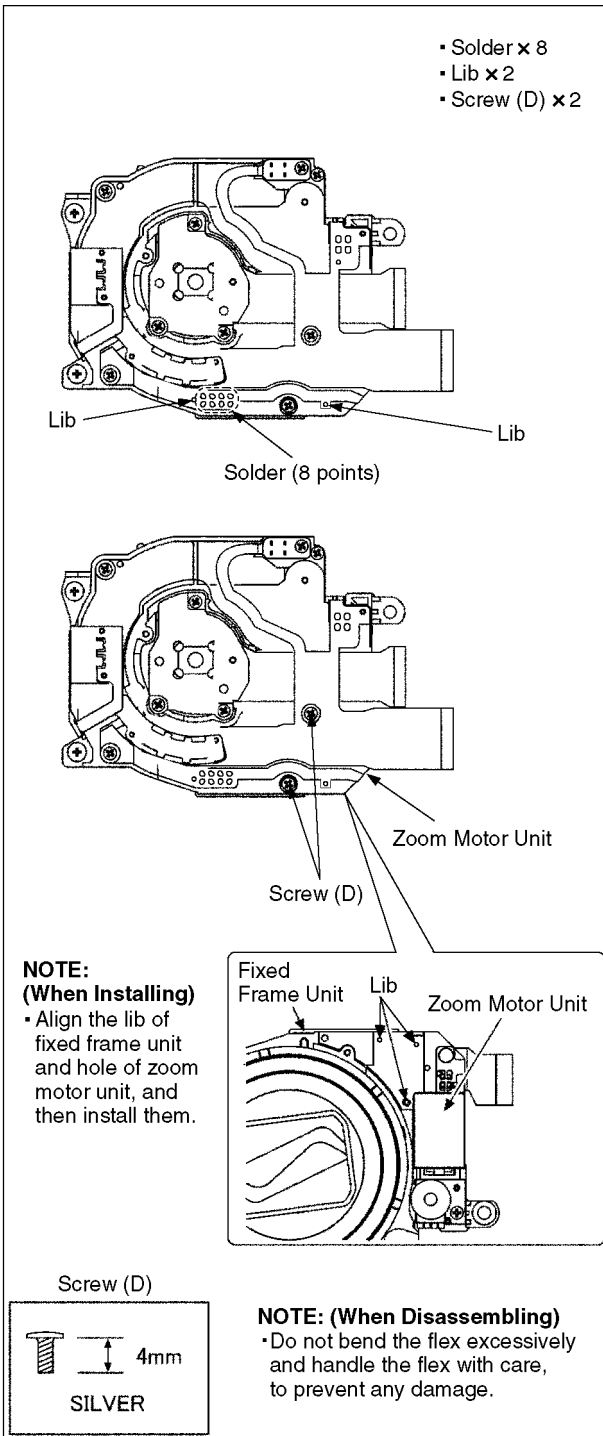

8.8. Removal of the Focus Motor Unit

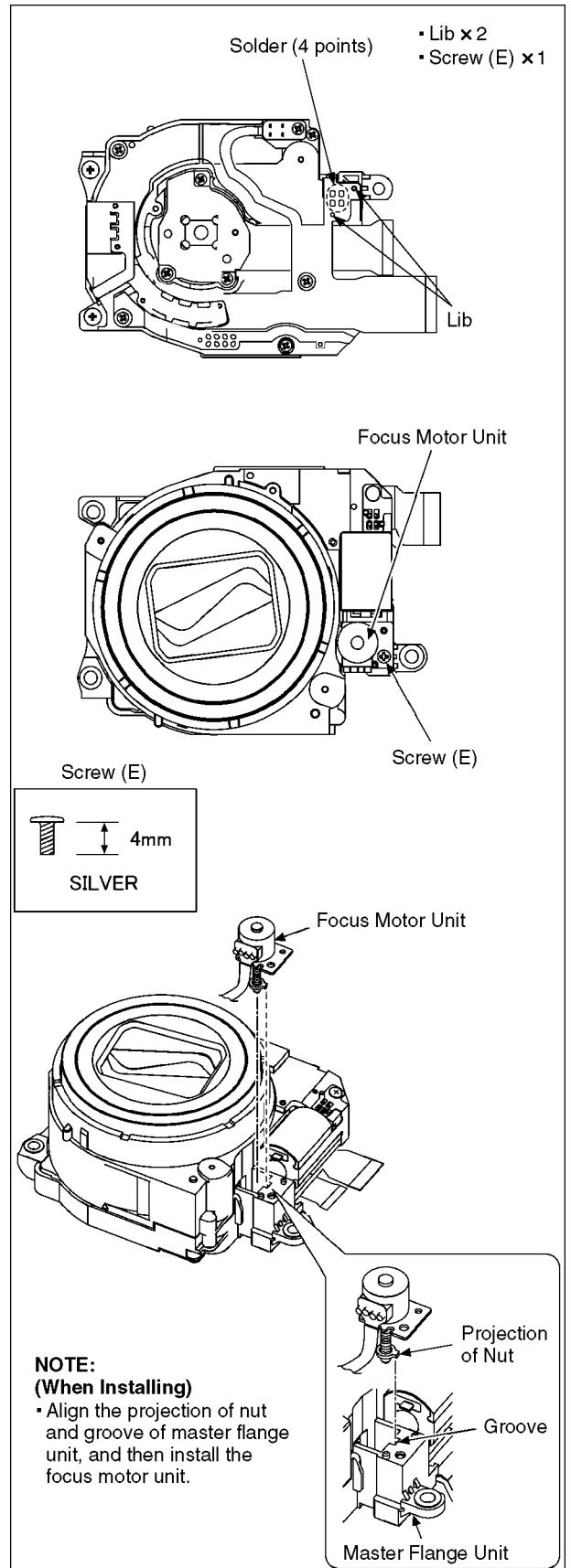

8.9. The Appliment of Grease Method

The grease apply point of lens unit are as follows.

Apply grease additionally in the specified position if necessary.

When the grease is applied, use a toothpick and apply thinly.

- Focus motor nut moving part
 - Grease: RFKZ0472
 - Amount of apply: 3 - 5 mg
- 4th lens frame positioning pole, guide pole
 - Grease: RFKZ0472
 - Amount of apply: 0.15 - 0.35 mg

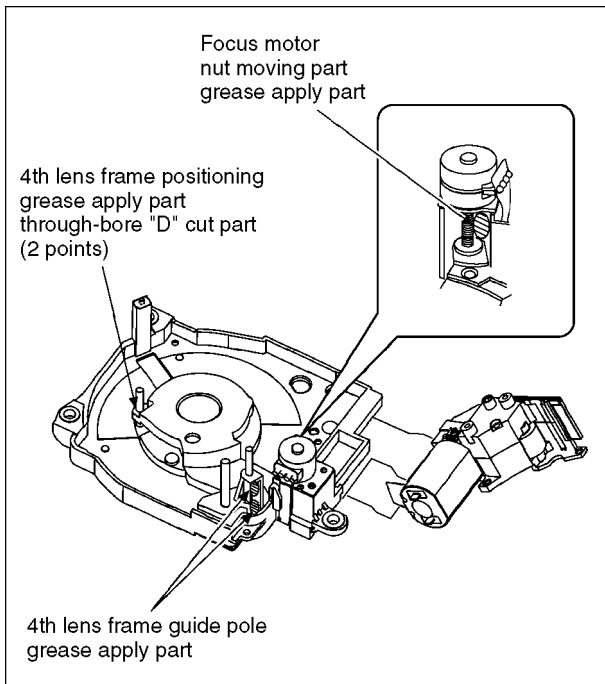

9 Measurements and Adjustments

9.1. Matrix Chart for Replaced Part and Necessary Adjustment

The relation between Replaced part and Necessary Adjustment is shown in the following table.

When concerned part is replaced, be sure to achieve the necessary adjustment(s).

As for Adjustment condition/procedure, consult the "Adjustment Manual" which is available in Adjustment software.

The Adjustment software is available at "TSN Website", therefore, access to "TSN Website" at "Support Information from NWBG/VDBG-PAVC".

NOTE:

After adjustments have been terminated, make sure to achieve "INITIAL SETTINGS".

Adjustment Item		Replaced Part				
		Main P.C.B.	VENUS (IC6001)	Flash-ROM (IC6002)	Lens Part (Excluding CCD)	CCD Unit
Camera Section	OIS hall element adjustment (OIS)	○	○	○	○	-
	Back focus adjustment (BF)	○	○	○	○	○*1
	Shutter adjustment (SHT)	○	○	○	○	○
	ISO sensitivity adjustment (ISO)	○	○	○	○	○
	AWB adjustment	○	○	○	○	○
	High brightness coloration inspection (WBL)	○	○	○	○	○
	CCD white scratch compensation (WKI)	○	○	○	-	○*1
CCD black scratch compensation (BKl)	○	○	○	-	○*1	

*1 This adjustment is necessary, not only replacing CCD unit but also removing it from the lens unit.

NOTE:

*There is no LCD adjustment in this model.

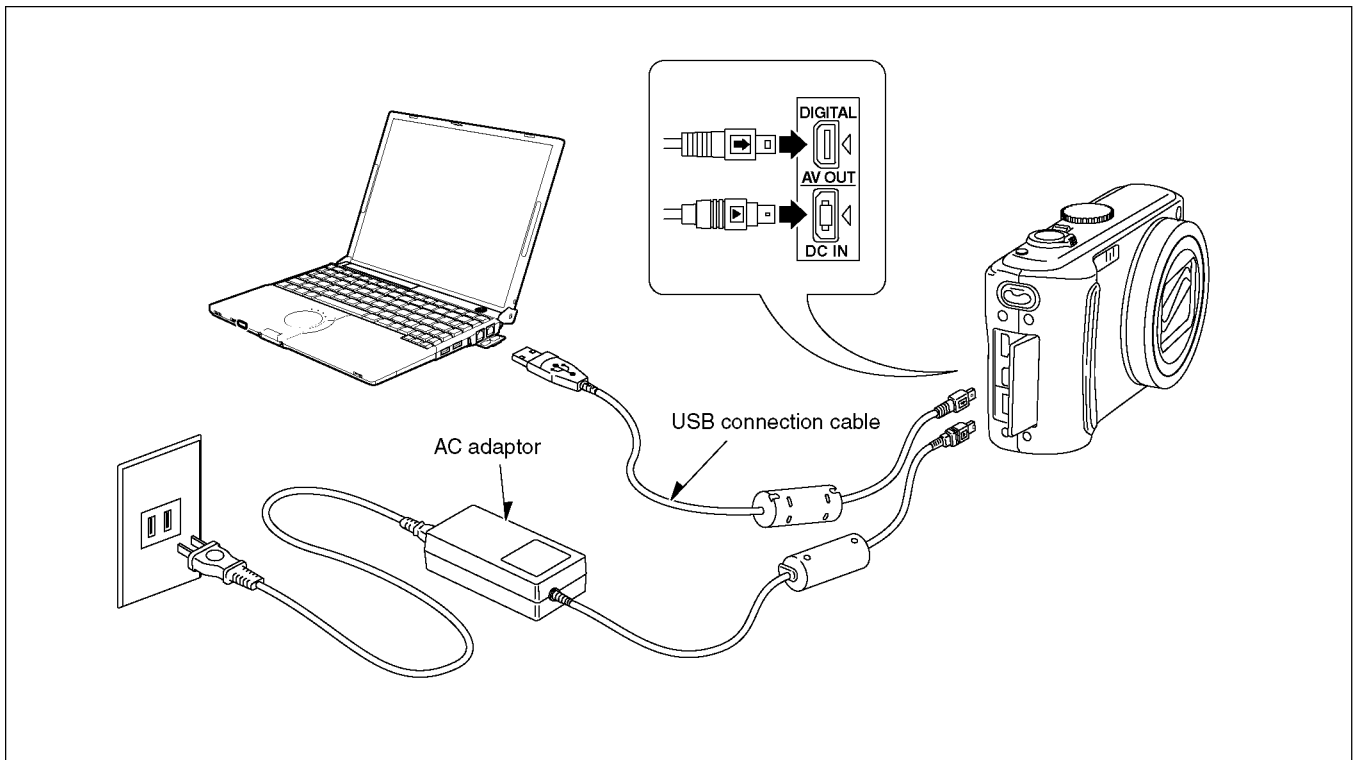

10 Maintenance

10.1. Cleaning Lens, Viewfinder and LCD Panel

Do not touch the surface of lens, Viewfinder and LCD Panel with your hand.

When cleaning the lens, use air-Blower to blow off the dust.

When cleaning the LCD Panel, dampen the lens cleaning paper with lens cleaner, and the gently wipe the their surface.

Note:

The Lens Cleaning KIT ; VFK1900BK(Only supplied as 10 set/Box) is available as Service Aid.

Service Manual

Diagrams and Replacement Parts List

Digital Camera

Model No.

DMC-TZ4P	DMC-TZ4E
DMC-TZ4PC	DMC-TZ11GC
DMC-TZ4PL	DMC-TZ11GK
DMC-TZ4EB	DMC-TZ11GN
DMC-TZ4EE	DMC-TZ11GT
DMC-TZ4EF	DMC-TZ11GJ
DMC-TZ4EG	

Vol. 1
 Colour
 (S).....Silver Type
 (K).....Black Type (except GT)

S1. About Indication of The Schematic Diagram

S1.1. Important Safety Notice

COMPONENTS IDENTIFIED WITH THE MARK \triangle HAVE THE SPECIAL CHARACTERISTICS FOR SAFETY. WHEN REPLACING ANY OF THESE COMPONENTS USE ONLY THE SAME TYPE.

- 1.Although reference number of the parts is indicated on the P.C.B. drawing and/or schematic diagrams, it is NOT mounted on the P.C.B. when it is displayed with "\$" mark.
- 2.It is only the "Test Round" and no terminal (Pin) is available on the P.C.B. when the TP (Test Point) indicated as "●" mark.
- 3.The voltage being indicated on the schematic diagram is measured in "Standard-Playback" mode when there is no specify mode is mentioned.
- 4.Although the voltage and waveform available on here is measured with standard frame, it may be differ from actual measurement due to modification of circuit and so on.
- 5.The voltage being indicated here may be include observational-error (deviation) due to internal-resistance and/or reactance of equipment. Therefore, handle the value indicated on here as reference.
- 6.Use the parts number indicated on the Replacement Parts List .
- 7.Indication on Schematic diagrams:

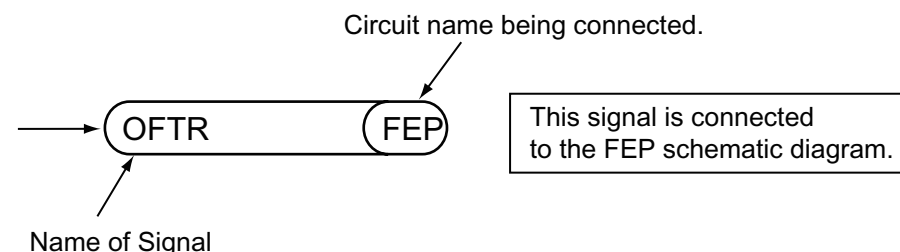

Table of contents

S1. About Indication of The Schematic Diagram.....	S-1	S6. Replacement Parts List.....	S-13
S1.1. Important Safety Notice.....	S-1	S7. Exploded View	S-17
S2. Voltage Chart	S-2	S7.1. Frame and Casing Section.....	S-17
S2.1. Flash P.C.B.	S-2	S7.2. Packing Parts and Accessories Section.....	S-18
S3. Block Diagram.....	S-3		
S3.1. Overall Block Diagram	S-3		
S4. Schematic Diagram.....	S-4		
S4.1. Interconnection Diagram	S-4		
S4.2. Flash Schematic Diagram	S-5		
S4.3. Top Operation Schematic Diagram	S-6		
S4.4. CCD Flex Schematic Diagram	S-7		
S4.5. Lens Flex Schematic Diagram	S-8		
S5. Print Circuit Board	S-9		
S5.1. Flash P.C.B.	S-9		
S5.2. Top Operation P.C.B.....	S-10		
S5.3. CCD Flex P.C.B.....	S-11		
S5.4. Lens Flex P.C.B.....	S-12		

S2. Voltage Chart

Note) Indicated voltage values are the standard values for the unit measured by the DC electronic circuit tester (high-impedance) with the chassis taken as standard.
Therefore, there may exist some errors in the voltage values, depending on the internal impedance of the DC circuit tester.

S2.1. Flash P.C.B.

REF No.	PIN No.	POWER ON
IC8001	1	-
IC8001	2	0
IC8001	3	4.9
IC8001	4	0
IC8001	5	0
Q8009	1	5.1
Q8009	2	5.1
Q8009	3	0
Q8009	4	0
Q8009	5	5.1
Q8009	6	5.1

S3. Block Diagram

S3.1. Overall Block Diagram

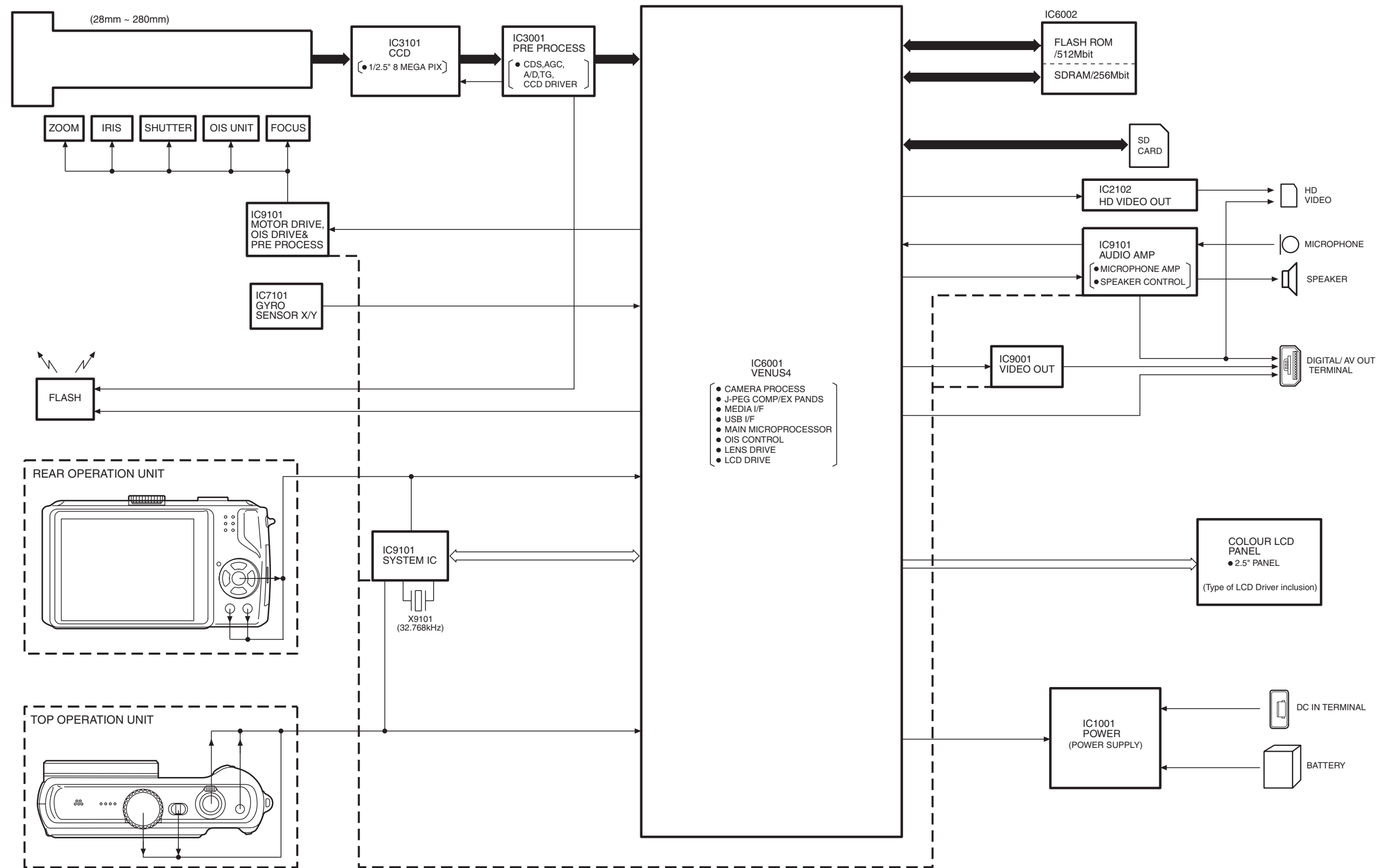

S4.2. Flash Schematic Diagram

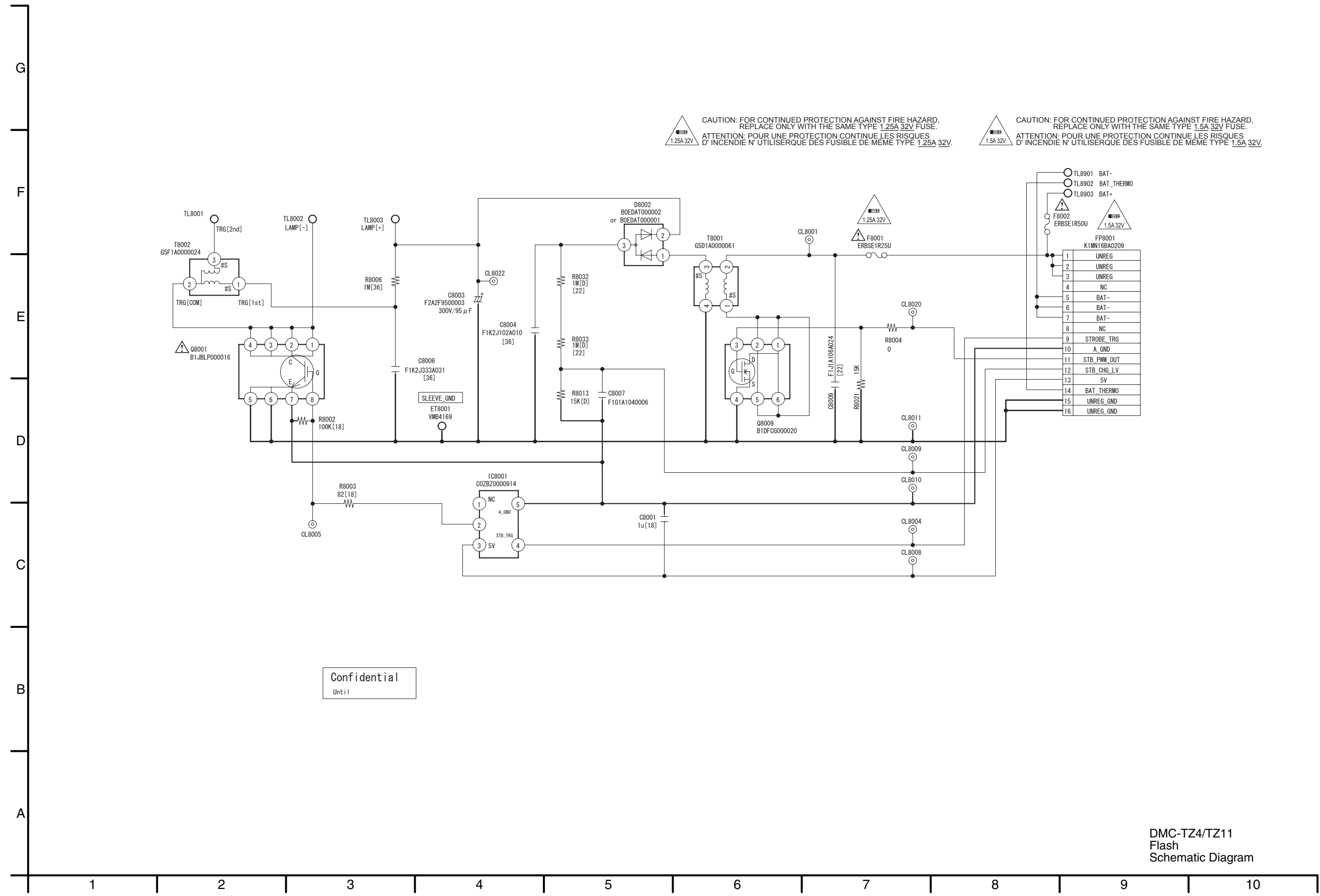

Confidential
Until

S4.3. Top Operation Schematic Diagram

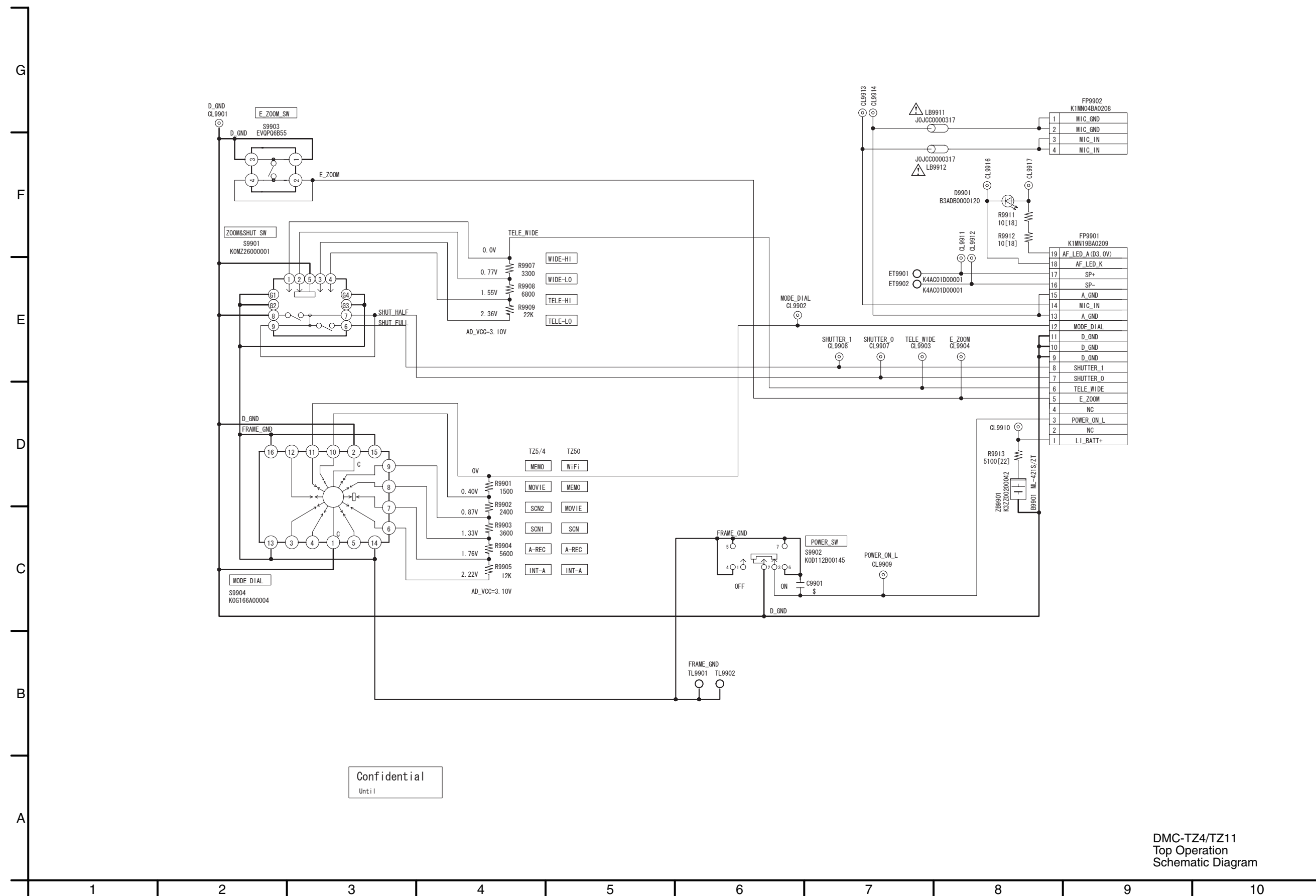

Confidential
Until

S4.4. CCD Flex Schematic Diagram

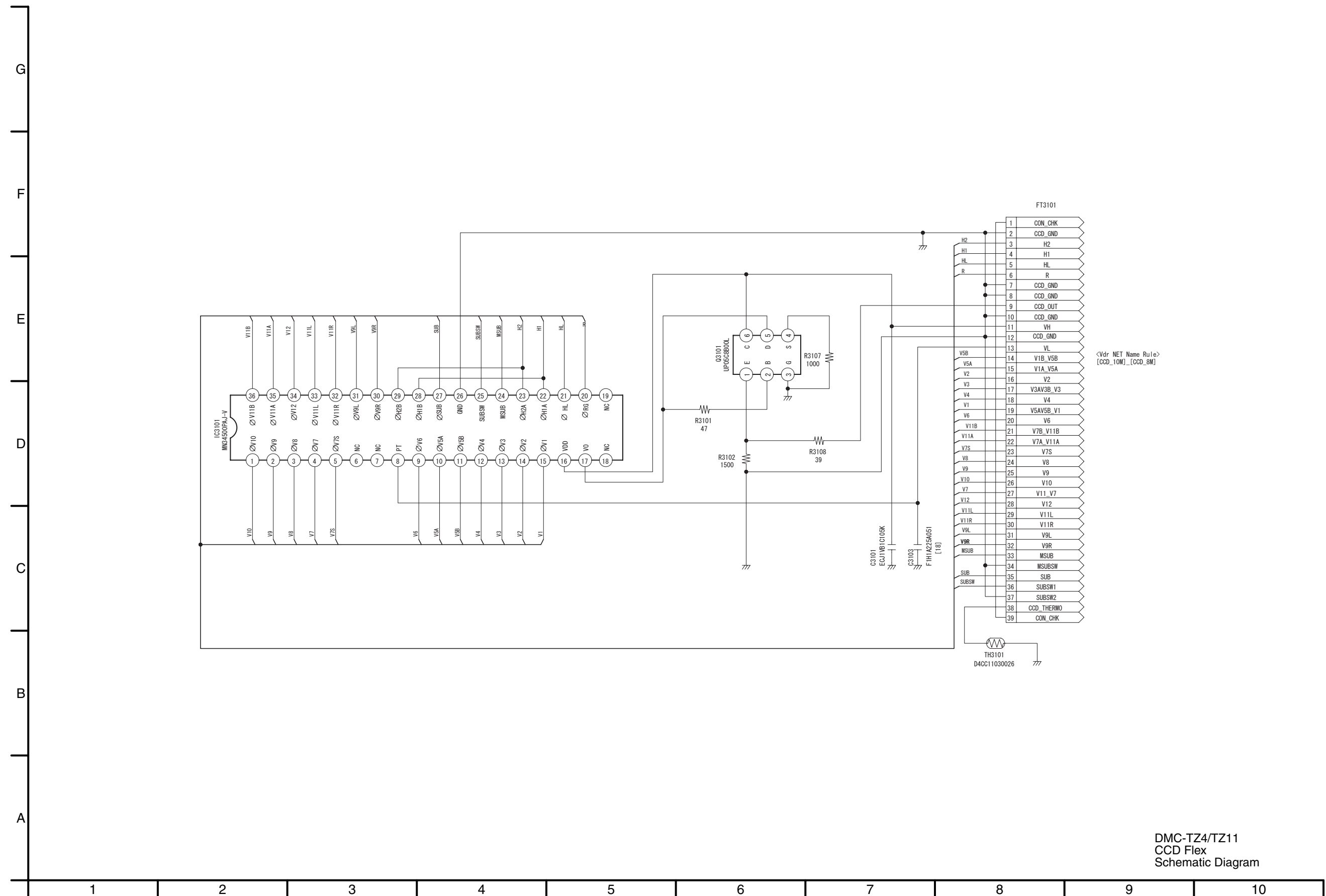

DMC-TZ4/TZ11
CCD Flex
Schematic Diagram

S4.5. Lens Flex Schematic Diagram

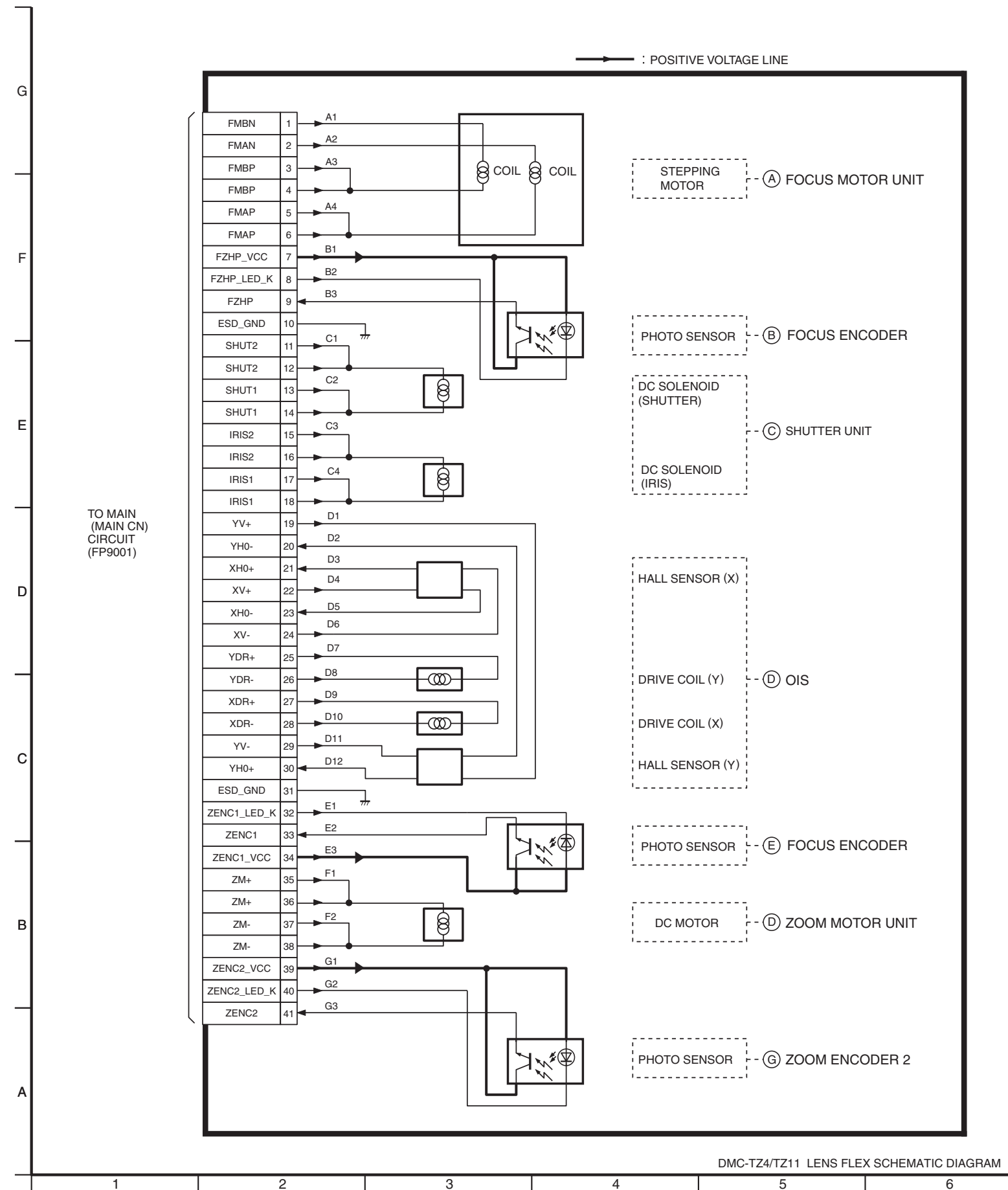

S5. Print Circuit Board

S5.1. Flash P.C.B.

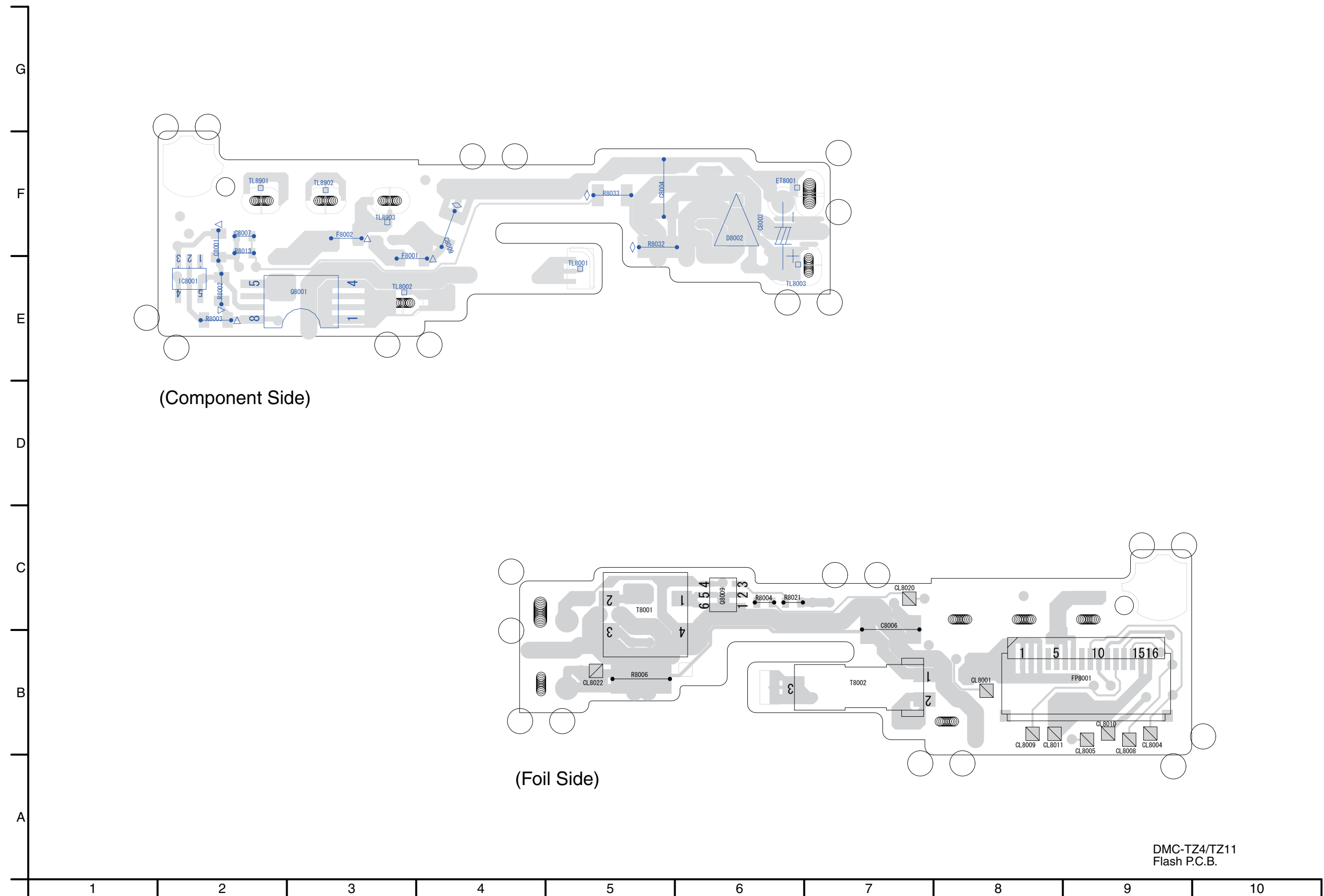

S5.2. Top Operation P.C.B.

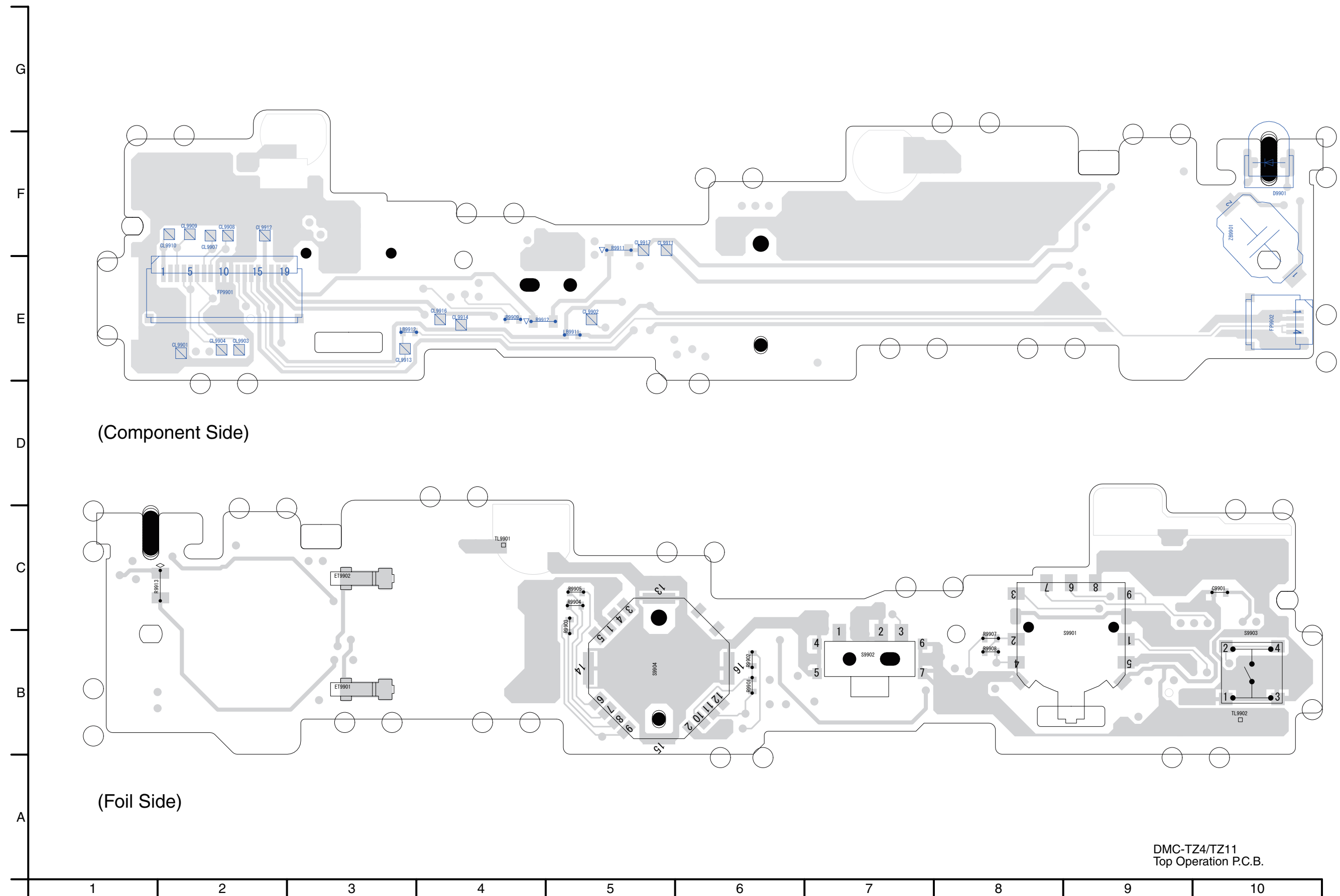

S5.3. CCD Flex P.C.B.

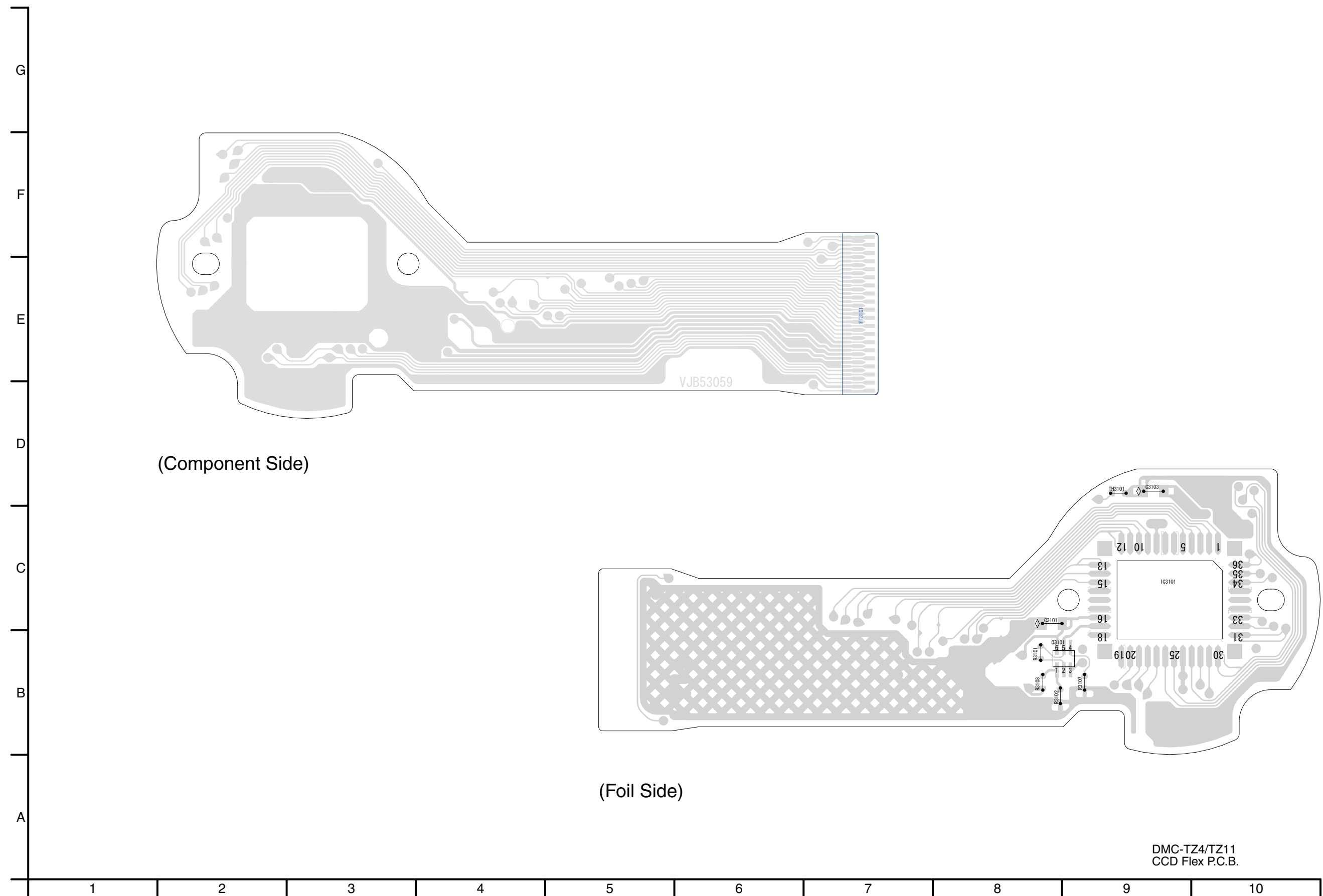

S5.4. Lens Flex P.C.B.

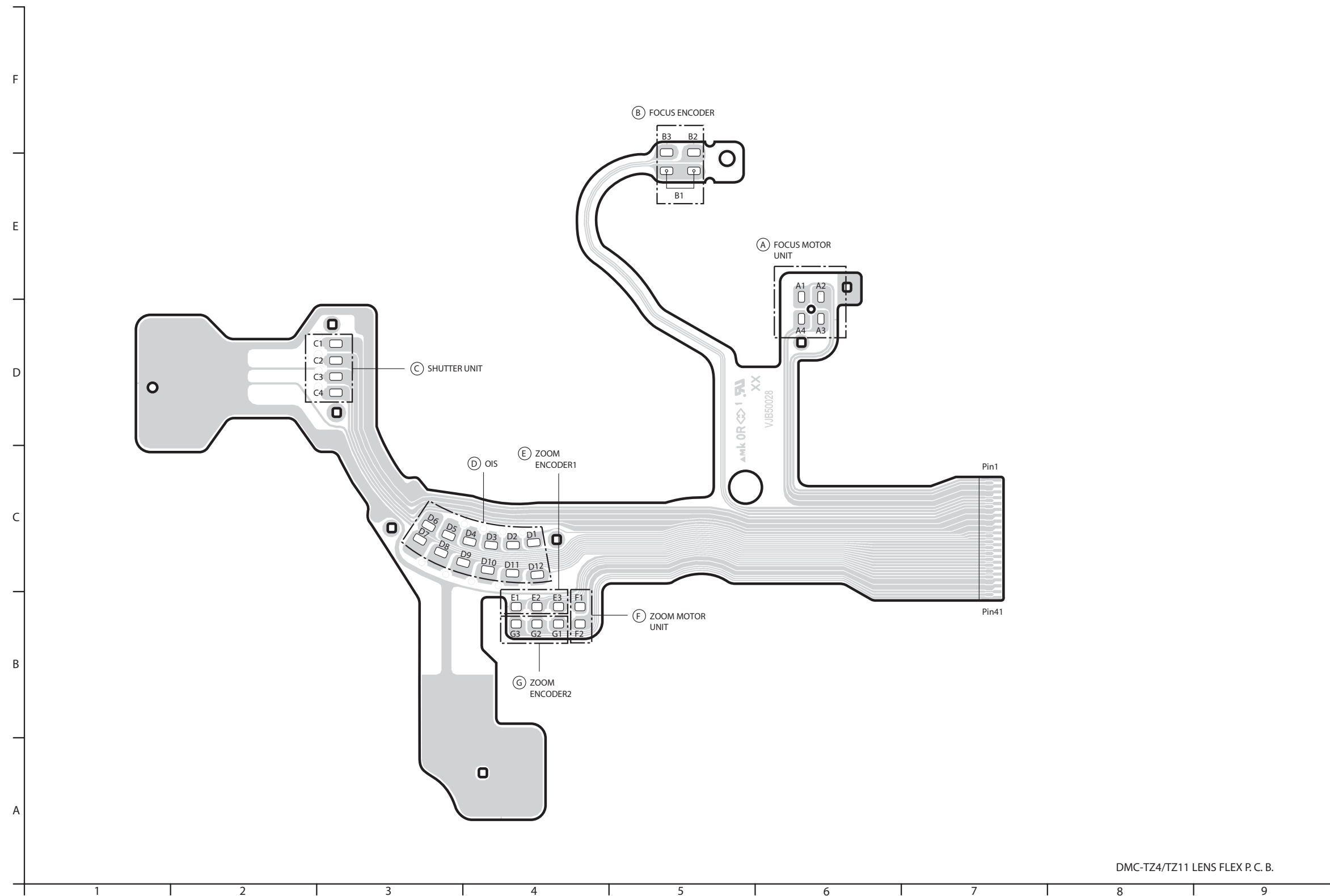

DMC-TZ4/TZ11 LENS FLEX P.C.B.

S6. Replacement Parts List

- Note: 1.* Be sure to make your orders of replacement parts according to this list.
2. IMPORTANT SAFETY NOTICE
Components identified with the mark \triangle have the special characteristics for safety.
When replacing any of these components, use only the same type.
3. Unless otherwise specified,
All resistors are in OHMS, K=1,000 OHMS. All capacitors are in MICRO-FARADS (uf), P=uuF.
4. The marking (RTL) indicates the retention time is limited for this item. After the discontinuation of this assembly in production, it will no longer be available.
5. Supply of CD-ROM, in accordance with license protection, is allowable as replacement parts only for customers who accidentally damaged or lost their own.

E.S.D. standards for Electrostatically Sensitive Devices, refer to PREVENTION OF ELECTROSTATIC DISCHARGE (ESD) TO ELECTROSTATICALLY SENSITIVE (ES) DEVICES section.

Definition of Parts supplier:

1. **Parts marked with [MBI] in the remarks column are supplied from Matsushita Battery Industrial Co., Ltd.**

Ref.No.	Part No.	Part Name & Description	Pcs	Remarks
##	VEP51020B	SUB P.C.B.	1	(RTL)E.S.D.
##	VEP56063B	MAIN P.C.B.	1	(RTL)E.S.D.
##	VEP59052A	TOP OPERATION P.C.B.	1	(RTL)E.S.D.
##	VEP58055A	FLASH P.C.B.	1	(RTL)E.S.D.
##	VEK0L99	CCD UNIT	1	E.S.D.
##	VEP59052A	TOP OPERATION P.C.B.	1	(RTL)E.S.D.
D9901	B3ADB0000120	LED	1	E.S.D.
ET9901	K4AC01D00001	EARTH SPRING	1	
ET9902	K4AC01D00001	EARTH SPRING	1	
FP9901	K1MN19BA0209	CONNECTOR 19P	1	
FP9902	K1MN04BA0208	CONNECTOR 4P	1	
△ LB9911	JOJCC0000317	FILTER	1	
△ LB9912	JOJCC0000317	FILTER	1	
R9901	ERJ2GEJ152	M.RESISTOR CH 1/16W 1.5K	1	
R9902	ERJ2GEJ242	M.RESISTOR CH 1/16W 2.4K	1	
R9903	ERJ2GEJ362	M.RESISTOR CH 1/16W 3.6K	1	
R9904	ERJ2GEJ562	M.RESISTOR CH 1/16W 5.6K	1	
R9905	ERJ2GEJ123	M.RESISTOR CH 1/16W 12K	1	
R9907	ERJ2GEJ332	M.RESISTOR CH 1/16W 3.3K	1	
R9908	ERJ2RHD682X	M.RESISTOR CH 1/16W 6.8K	1	
R9909	ERJ2GEJ223	M.RESISTOR CH 1/16W 22K	1	
R9911	ERJ3GEYJ100	M.RESISTOR CH 1/10W 10	1	
R9912	ERJ3GEYJ100	M.RESISTOR CH 1/10W 10	1	
R9913	ERJ6GEYJ512	M.RESISTOR CH 1/10W 5.1K	1	
S9901	K0MZ26000001	SWITCH	1	
S9902	K0D112B00145	SWITCH	1	
S9903	EVOP06B55	SWITCH	1	
S9904	K0G166A00004	ROTARY SWITCH	1	
ZB9901	K3ZZ00200042	BATTERY HOLDER	1	
##	VEP58055A	FLASH P.C.B.	1	(RTL)E.S.D.
C8001	ECJ1VB0J105K	C.CAPACITOR CH 6.3V 1U	1	
C8004	F1K2J102A010	C.CAPACITOR 630V 1000P	1	
C8006	F1K2J333A031	C.CAPACITOR 630V 0.033U	1	
C8007	F1G1A1040006	C.CAPACITOR CH 10V 0.1U	1	
C8009	F1J1A106A024	C.CAPACITOR CH 10V 10U	1	
D8002	B0EDAT000002	DIODE	1	E.S.D.
△ F8001	ERBSE1R25U	FUSE 32V 1.25A	1	
△ F8002	ERBSE1R50U	FUSE 32V 1.5A	1	
FP8001	K1MN16BA0209	CONNECTOR 16P	1	
IC8001	C0ZBZ0000914	IC	1	E.S.D.
△ Q8001	B1JBLP000016	TRANSISTOR	1	E.S.D.
Q8009	B1DFCG000020	TRANSISTOR	1	E.S.D.
R8002	ERJ3GEYJ104	M.RESISTOR CH 1/10W 100K	1	
R8003	ERJ3GEYJ820	M.RESISTOR CH 1/10W 82	1	
R8004	D0YAR0000007	M.RESISTOR CH 1/16W 0	1	
R8006	ERJ8GEYJ105V	M.RESISTOR CH 1/8W 1M	1	
R8013	ERJ2RHD153X	M.RESISTOR CH 1/16W 15K	1	
R8021	ERJ2GEJ153	M.RESISTOR CH 1/16W 15K	1	
R8032	ERJ6RED105	M.RESISTOR CH 1/16W 1M	1	
R8033	ERJ6RED105	M.RESISTOR CH 1/16W 1M	1	
T8001	G5D1A000061	TRANSFORMER	1	

Ref.No.	Part No.	Part Name & Description	Pcs	Remarks
T8002	G5F1A0000024	TRANSFORMER	1	
##	VEK0L99	CCD UNIT	1	E.S.D.
C3101	ECJ1VB1C105K	C.CAPACITOR CH 16V 1U	1	
C3103	F1H1A225A051	C.CAPACITOR CH 10V 2.2U	1	
Q3101	UP05C8B00L	TRANSISTOR	1	E.S.D.
R3101	ERJ2GEJ470	M.RESISTOR CH 1/16W 47	1	
R3102	ERJ2GEJ152	M.RESISTOR CH 1/16W 1.5K	1	
R3107	ERJ2GEJ102X	M.RESISTOR CH 1/16W 1K	1	
R3108	ERJ2GEJ390	M.RESISTOR CH 1/16W 39	1	
TH3101	D4CC11030026	THERMISTER	1	

Ref.No.	Part No.	Part Name & Description	Pcs	Remarks	Ref.No.	Part No.	Part Name & Description	Pcs	Remarks
301	VPF1137	CAMERA BAG	1		314	VQT1P95	SIMPLIFIED O/I (ARABIC/PERSIAN)	1	TZ11GC
△ 302	K2CT3CA00004	AC CORD W/PLUG	1	TZ4EB, TZ11GC	314	VQT1P97	INSTRUCTION BOOK (CHINESE(SIMPLIFIED))	1	TZ11GK
△ 302	K2CQ2CA00006	AC CORD W/PLUG	1	TZ4EE,EF,EG,E, TZ11GC	314	VQT1P98	INSTRUCTION BOOK (ENGLISH)	1	TZ11GN
△ 302	K2CA2CA00020	AC CORD W/PLUG	1	TZ11GK	314	VQT1P96	INSTRUCTION BOOK (CHINESE(TRADITIONAL))	1	TZ11GT
△ 302	K2CJ2DA00008	AC CORD W/PLUG	1	TZ11GN	314	VQT1Q79	INSTRUCTION BOOK (THAI)	1	TZ11GJ
△ 302	K2CA2CA00027	AC CORD W/PLUG	1	TZ11GT	315	VQT1M47	O/I SOFTWARE (ENGLISH/CANADIAN FRENCH)	1	TZ4P,PC
△ 302	K2CP2YY00001	AC CORD W/PLUG	1	TZ11GJ	315	VQT1M48	O/I SOFTWARE (ENGLISH/SPANISH/ PORTUGUESE)	1	TZ4PL
△ 303	----	BATTERY PACK	1	TZ4P,PC	315	VQT1M52	O/I SOFTWARE (ENGLISH)	1	TZ4EB, TZ11GN
△ 303	----	BATTERY PACK	1	TZ4PL,EB,EE,EF,EG,E, TZ11GC,GK,GN,GT,GJ	315	VQT1M53	O/I SOFTWARE (RUSSIAN/UKRAINIAN)	1	TZ4EE
△ 304	DE-A45BA	BATTERY CHARGER	1	TZ4P,PC,PL	315	VQT1M51	O/I SOFTWARE (FRENCH)	1	TZ4EF
△ 304	DE-A46AA	BATTERY CHARGER	1	TZ4EB,EF,EG,E, TZ11GN	315	VQT1M49	O/I SOFTWARE (GERMAN/ITALIAN/FRENCH/ DUTCH/SPANISH/ PORTUGUESE)	1	TZ4EG
△ 304	DE-A46BA	BATTERY CHARGER	1	TZ4EE, TZ11GC,GK,GJ	315	VQT1M50	O/I SOFTWARE (FINNISH/SWEDISH/DANISH/ POLISH/CZECH/HUNGARIAN)	1	TZ4E
△ 304	DE-A46CA	BATTERY CHARGER	1	TZ11GT	315	VQT1M54	O/I SOFTWARE (ENGLISH/ CHINESE(TRADITIONAL)/ ARABIC/PERSIAN)	1	TZ11GC
305	K1HA08CD0019	USB CABLE	1		315	VQT1M56	O/I SOFTWARE (CHINESE(SIMPLIFIED))	1	TZ11GK
306	K1HA08CD0020	AV CABLE	1		315	VQT1M55	O/I SOFTWARE (CHINESE(TRADITIONAL))	1	TZ11GT
307	VFC4297	HAND STRAP	1		315	VQT1Q76	O/I SOFTWARE (THAI)	1	TZ11GJ
308	VFF0400-S	CD-ROM	1	TZ4P,PC	316	VYQ3680	BATTERY CARRYING CASE U	1	EXCEPT TZ11GK
308	VFF0401-S	CD-ROM	1	TZ4PL,EB,EE,EF,EG,E, TZ11GC,GK,GN,GT,GJ	316	VYQ4386	BATTERY CARRYING CASE U	1	TZ11GK
309	VPK3450	PACKING CASE	1	TZ4P-S,PC-S					
309	VPK3512	PACKING CASE	1	TZ4P-K,PC-K					
309	VPK3451	PACKING CASE	1	TZ4PL-S,EB-S,EE-S,EF-S, EG-S,E-S					
309	VPK3513	PACKING CASE	1	TZ4PL-K,EB-K,EE-K,EF-K, EG-K,E-K					
309	VPK3452	PACKING CASE	1	TZ11GC-S,GN-S,GT-S,GJ-S					
309	VPK3514	PACKING CASE	1	TZ11GC-K,GN-K,GJ-K					
309	VPK3453	PACKING CASE	1	TZ11GK-S					
309	VPK3515	PACKING CASE	1	TZ11GK-K					
310	VPN6659	CUSHION	1						
311	VPN6664	PAD	1	TZ4PL,EE,EF,EG,E, TZ11GK,GN,GT,GJ					
311	VPN6666	PAD	1	TZ4EB, TZ11GC					
312	VPF1294	BAG, POLYETHYLENE	1						
313	VFF0413	CD-ROM (INSTRUCTION BOOK)	1	TZ4PL,EG,E, TZ11GC					
314	VQT1P80	INSTRUCTION BOOK (SPANISH)	1	TZ4P					
314	VQT1P79	INSTRUCTION BOOK (ENGLISH)	1	TZ4P,PC					
314	VQT1P81	INSTRUCTION BOOK (CANADIAN FRENCH)	1	TZ4PC					
314	VQT1P82	SIMPLIFIED O/I (ENGLISH/SPANISH)	1	TZ4PL					
314	VQT1P83	SIMPLIFIED O/I (PORTUGUESE)	1	TZ4PL					
314	VQT1P91	INSTRUCTION BOOK (ENGLISH)	1	TZ4EB					
314	VQT1P92	INSTRUCTION BOOK (RUSSIAN)	1	TZ4EE					
314	VQT1P93	INSTRUCTION BOOK (UKRAINIAN)	1	TZ4EE					
314	VQT1P90	INSTRUCTION BOOK (FRENCH)	1	TZ4EF					
314	VQT1P84	SIMPLIFIED O/I (GERMAN/FRENCH)	1	TZ4EG					
314	VQT1P85	SIMPLIFIED O/I (ITALIAN/DUTCH)	1	TZ4EG					
314	VQT1P86	SIMPLIFIED O/I (SPANISH/PORTUGUESE)	1	TZ4EG					
314	VQT1P87	SIMPLIFIED O/I (SWEDISH/DANISH)	1	TZ4E					
314	VQT1P88	SIMPLIFIED O/I (POLISH/CZECH)	1	TZ4E					
314	VQT1P89	SIMPLIFIED O/I (HUNGARIAN/FINNISH)	1	TZ4E					
314	VQT1P94	SIMPLIFIED O/I (ENGLISH/ CHINESE(TRADITIONAL))	1	TZ11GC					

S7. Exploded View

S7.1. Frame and Casing Section

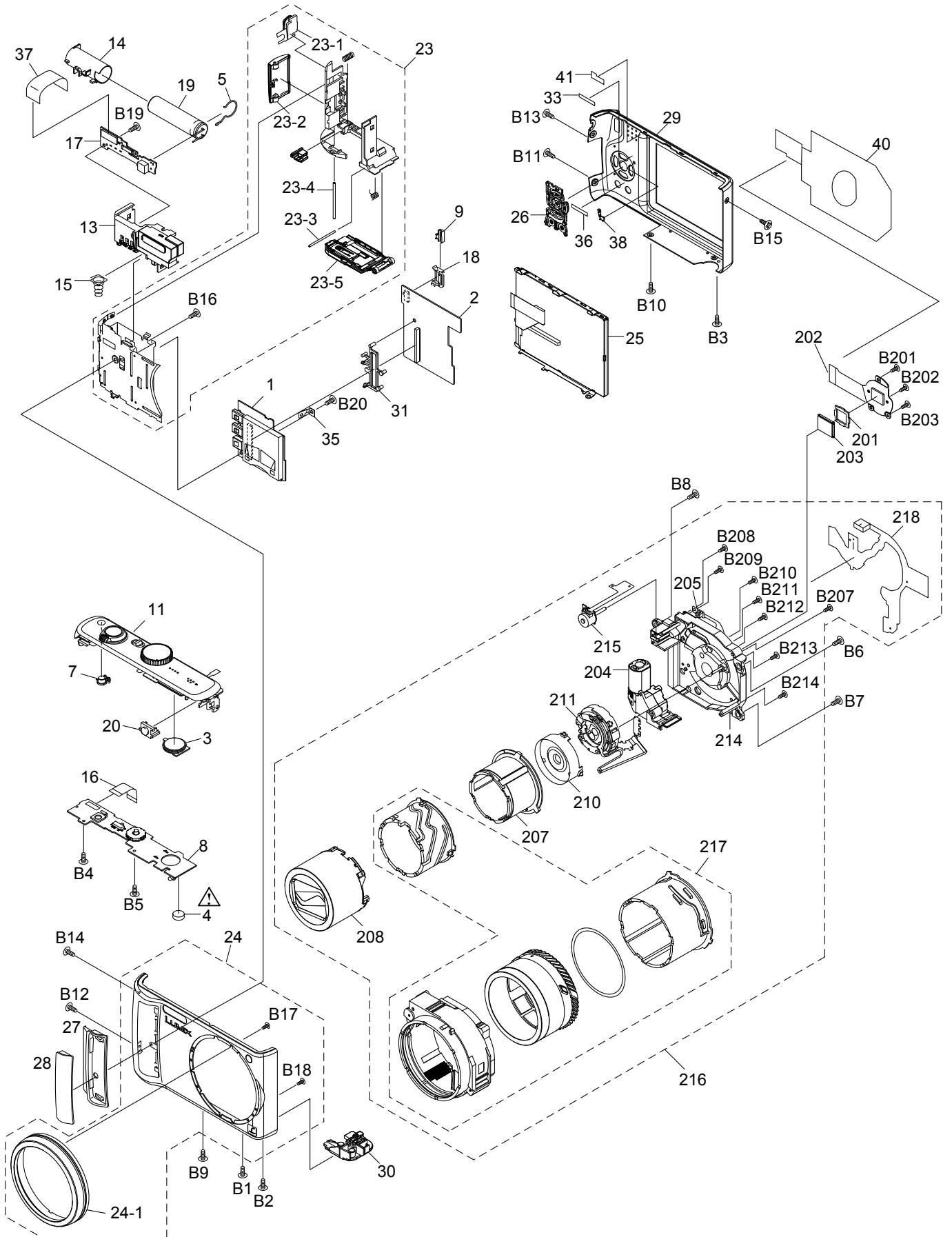

S7.2. Packing Parts and Accessories Section

