

Service Manual

Digital Camera

LUMIX

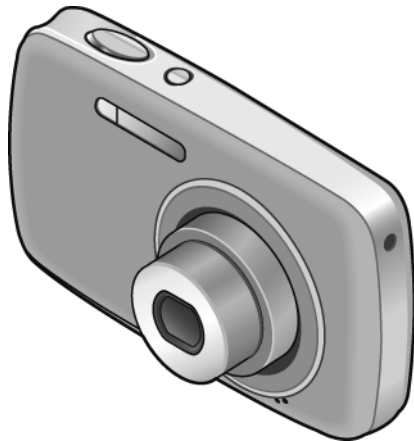

Model No. **DMC-S3P**

DMC-S3PC

DMC-S3PR

DMC-S3PU

DMC-S3EB

DMC-S3EE

DMC-S3EF

DMC-S3EG

DMC-S3EP

DMC-S3GA

DMC-S3GC

DMC-S3GD

DMC-S3GF

DMC-S3GK

DMC-S3GN

DMC-S3GT

DMC-S1P

DMC-S1PC

DMC-S1PR

DMC-S1PU

DMC-S1EB

DMC-S1EE

DMC-S1EF

DMC-S1EG

Panasonic[®]

DMC-S1EP
DMC-S1GA
DMC-S1GC
DMC-S1GD
DMC-S1GF
DMC-S1GK
DMC-S1GN
DMC-S1GT

Colour
[DMC-S1]
(A).....Blue Type (except PR/PU/EB/EF/GD/GK/GT)
(K).....Black Type
(N).....Gold Type (only P)
(P).....Pink Type (only GA/GC/GD/GF/GT)
(PA).....Pink Type (only P/PR/PU/EB/EE/EG/EP/GN)
(S).....Silver Type (except EB/EF/GD)
(W).....White Type (only GA/GC/GD/GF/GK/GN/GT)
[DMC-S3]
(A).....Blue Type (only P/PC/EB/EE/EG/EP/GK/GN)
(K).....Black Type
(R).....Red Type (except GD)
(V).....Violet Type (except PR/PU/EE/GD/GT)
(W).....White Type

⚠ WARNING

This service information is designed for experienced repair technicians only and is not designed for use by the general public. It does not contain warnings or cautions to advise non-technical individuals of potential dangers in attempting to service a product. Products powered by electricity should be serviced or repaired only by experienced professional technicians. Any attempt to service or repair the product or products dealt with in this service information by anyone else could result in serious injury or death.

TABLE OF CONTENTS

	PAGE		PAGE
1 Safety Precautions	3	7 Service Fixture & Tools	21
1.1. General Guidelines	3	7.1. Service Fixture and Tools.....	21
1.2. Leakage Current Cold Check	3	7.2. When Replacing the Main P.C.B.	21
1.3. Leakage Current Hot Check (See Figure 1.).....	3	8 Disassembly and Assembly Instructions	22
1.4. How to Discharge the E.Capacitor on Flash P.C.B.....	4	8.1. Disassembly Flow Chart	22
2 Warning	5	8.2. P.C.B. Location	22
2.1. Prevention of Electrostatic Discharge (ESD) to Electrostatically Sensitive (ES) Devices	5	8.3. Disassembly Procedure.....	22
2.2. How to Recycle the Lithium Ion Battery (U.S. Only).....	5	8.4. Removal of the CCD Unit.....	28
2.3. Caution for AC Cord(For EB/GC)	6	9 Measurements and Adjustments	29
2.4. How to Replace the Lithium Battery.....	7	9.1. Introduction.....	29
3 Service Navigation	8	9.2. Before Disassembling the unit	29
3.1. Introduction	8	9.3. Details of Electrical Adjustment	31
3.2. Important Notice (About minimum replacement part size: MAIN P.C.B. & LENS UNIT)	8	9.4. After Adjustment	35
3.3. General Description About Lead Free Solder (PbF)	9	10 Maintenance	36
3.4. Important Notice 1:(Other than U.S.A. and Canadian Market).....	9	10.1. Cleaning Lens and LCD Panel	36
3.5. How to Define the Model Suffix (NTSC or PAL model).....	10		
4 Specifications	15		
5 Location of Controls and Components	16		
6 Service Mode	18		
6.1. Error Code Memory Function	18		

1 Safety Precautions

1.1. General Guidelines

1. IMPORTANT SAFETY NOTICE

There are special components used in this equipment which are important for safety. These parts are marked by

 in the Schematic Diagrams, Circuit Board Layout, Exploded Views and Replacement Parts List. It is essential that these critical parts should be replaced with manufacturer's specified parts to prevent X-RADIATION, shock, fire, or other hazards. Do not modify the original design without permission of manufacturer.

2. An Isolation Transformer should always be used during the servicing of AC Adaptor whose chassis is not isolated from the AC power line. Use a transformer of adequate power rating as this protects the technician from accidents resulting in personal injury from electrical shocks. It will also protect AC Adaptor from being damaged by accidental shorting that may occur during servicing.
3. When servicing, observe the original lead dress. If a short circuit is found, replace all parts which have been overheated or damaged by the short circuit.
4. After servicing, see to it that all the protective devices such as insulation barriers, insulation papers shields are properly installed.
5. After servicing, make the following leakage current checks to prevent the customer from being exposed to shock hazards.

1.2. Leakage Current Cold Check

1. Unplug the AC cord and connect a jumper between the two prongs on the plug.
2. Measure the resistance value, with an ohmmeter, between the jumpered AC plug and each exposed metallic cabinet part on the equipment such as screwheads, connectors, control shafts, etc. When the exposed metallic part has a return path to the chassis, the reading should be between $1\text{ M}\Omega$ and $5.2\text{ M}\Omega$. When the exposed metal does not have a return path to the chassis, the reading must be infinity.

1.3. Leakage Current Hot Check (See Figure 1.)

1. Plug the AC cord directly into the AC outlet. Do not use an isolation transformer for this check.
2. Connect a $1.5\text{ k}\Omega$, 10 W resistor, in parallel with a $0.15\text{ }\mu\text{F}$ capacitor, between each exposed metallic part on the set and a good earth ground, as shown in Figure 1.
3. Use an AC voltmeter, with $1\text{ k}\Omega/\text{V}$ or more sensitivity, to measure the potential across the resistor.
4. Check each exposed metallic part, and measure the voltage at each point.
5. Reverse the AC plug in the AC outlet and repeat each of the above measurements.
6. The potential at any point should not exceed 0.75 V RMS . A leakage current tester (Simpson Model 229 or equivalent) may be used to make the hot checks, leakage current must not exceed $1/2\text{ mA}$. In case a measurement is outside of the limits specified, there is a possibility of a shock hazard, and the equipment should be repaired and rechecked before it is returned to the customer.

Hot-Check Circuit



Figure. 1

1.4. How to Discharge the E.Capacitor on Flash P.C.B.

CAUTION:

1. Be sure to discharge the E.capacitor on FLASH P.C.B..
2. Be careful of the high voltage circuit on FLASH P.C.B. when servicing.

[Discharging Procedure]

1. Refer to the disassemble procedure and remove the necessary parts/unit.
2. Install the insulation tube onto the lead part of resistor (ERG5SJ102:1k Ω /5W).
(An equivalent type of resistor may be used.)
3. Place a resistor between both terminals of E.capacitor on the FLASH P.C.B. for approx. 5 seconds.
4. After discharging, confirm that the E.capacitor voltage is lower than 10V by using a voltmeter.

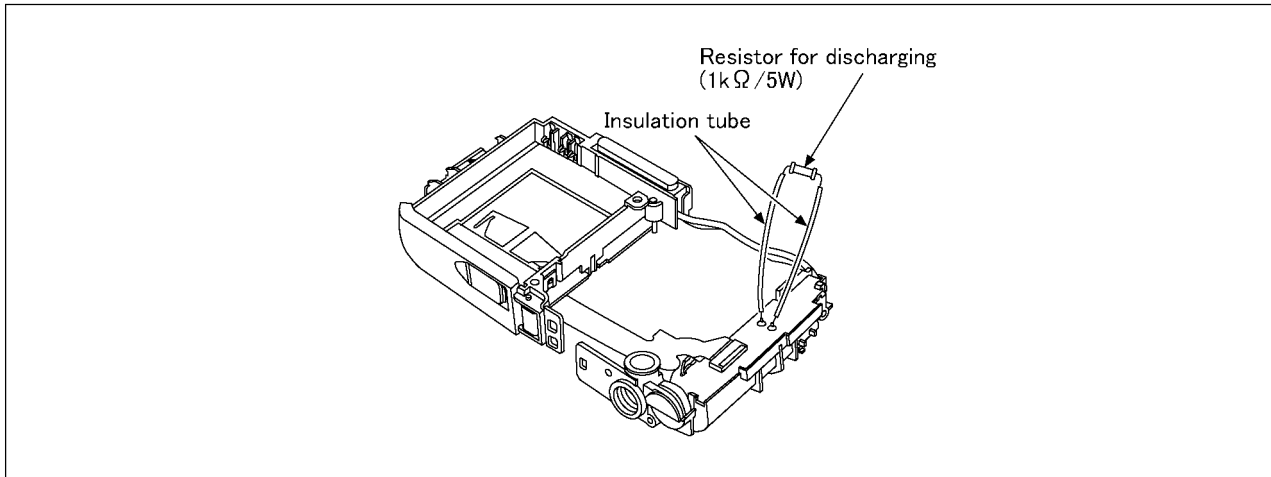

Fig. F1

2 Warning

2.1. Prevention of Electrostatic Discharge (ESD) to Electrostatically Sensitive (ES) Devices

Some semiconductor (solid state) devices can be damaged easily by static electricity. Such components commonly are called Electrostatically Sensitive (ES) Devices.

Examples of typical ES devices are IC (integrated circuits) and some field-effect transistors and semiconductor "chip" components.

The following techniques should be used to help reduce the incidence of component damage caused by electrostatic discharge (ESD).

1. Immediately before handling any semiconductor component or semiconductor-equipped assembly, drain off any ESD on your body by touching a known earth ground. Alternatively, obtain and wear a commercially available discharging ESD wrist strap, which should be removed for potential shock reasons prior to applying power to the unit under test.
2. After removing an electrical assembly equipped with ES devices, place the assembly on a conductive surface such as aluminum foil, to prevent electrostatic charge buildup or exposure of the assembly.
3. Use only a grounded-tip soldering iron to solder or unsolder ES devices.
4. Use only an antistatic solder removal device. Some solder removal devices not classified as "antistatic (ESD protected)" can generate electrical charge sufficient to damage ES devices.
5. Do not use freon-propelled chemicals. These can generate electrical charges sufficient to damage ES devices.
6. Do not remove a replacement ES device from its protective package until immediately before you are ready to install it. (Most replacement ES devices are packaged with leads electrically shorted together by conductive foam, aluminum foil or comparable conductive material).
7. Immediately before removing the protective material from the leads of a replacement ES device, touch the protective material to the chassis or circuit assembly into which the device will be installed.

CAUTION :

Be sure no power is applied to the chassis or circuit, and observe all other safety precautions.

8. Minimize bodily motions when handling unpackaged replacement ES devices. (Otherwise harmless motion such as the brushing together of your clothes fabric or the lifting of your foot from a carpeted floor can generate static electricity (ESD) sufficient to damage an ES device).

2.2. How to Recycle the Lithium Ion Battery (U.S. Only)

ENGLISH



A lithium ion battery that is recyclable powers the product you have purchased. Please call 1-800-8-BATTERY for information on how to recycle this battery.

FRANÇAIS



L'appareil que vous vous êtes procuré est alimenté par une batterie au lithium-ion recyclable. Pour des renseignements sur le recyclage de la batterie, veuillez composer le 1-800-8-BATTERY.

2.3. Caution for AC Cord (For EB/GC)

2.3.1. Information for Your Safety

IMPORTANT

Your attention is drawn to the fact that recording of pre-recorded tapes or discs or other published or broadcast material may infringe copyright laws.

WARNING

To reduce the risk of fire or shock hazard, do not expose this equipment to rain or moisture.

CAUTION

To reduce the risk of fire or shock hazard and annoying interference, use the recommended accessories only.

FOR YOUR SAFETY

DO NOT REMOVE THE OUTER COVER

To prevent electric shock, do not remove the cover. No user serviceable parts inside. Refer servicing to qualified service personnel.

2.3.2. Caution for AC Mains Lead

For your safety, please read the following text carefully.

This appliance is supplied with a moulded three-pin mains plug for your safety and convenience.

A 5-ampere fuse is fitted in this plug.

Should the fuse need to be replaced please ensure that the replacement fuse has a rating of 5 amperes and it is approved by ASTA or BSI to BS1362

Check for the ASTA mark or the BSI mark on the body of the fuse.



If the plug contains a removable fuse cover you must ensure that it is refitted when the fuse is replaced.

If you lose the fuse cover, the plug must not be used until a replacement cover is obtained.

A replacement fuse cover can be purchased from your local Panasonic Dealer.

If the fitted moulded plug is unsuitable for the socket outlet in your home then the fuse should be removed and the plug cut off and disposed of safely.

There is a danger of severe electrical shock if the cut off plug is inserted into any 13-ampere socket.

If a new plug is to be fitted please observe the wiring code as shown below.

If in any doubt, please consult a qualified electrician.

2.3.2.1. Important

The wires in this mains lead are coloured in accordance with the following code:

Blue	Neutral
Brown	Live

As the colours of the wires in the mains lead of this appliance may not correspond with the coloured markings identifying the terminals in your plug, proceed as follows:

The wire which is coloured BLUE must be connected to the terminal in the plug which is marked with the letter N or coloured BLACK.

The wire which is coloured BROWN must be connected to the terminal in the plug which is marked with the letter L or coloured RED.

Under no circumstances should either of these wires be connected to the earth terminal of the three pin plug, marked with the letter E or the Earth Symbol.

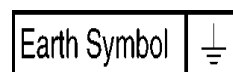

2.3.2.2. Before Use

Remove the Connector Cover as follows.

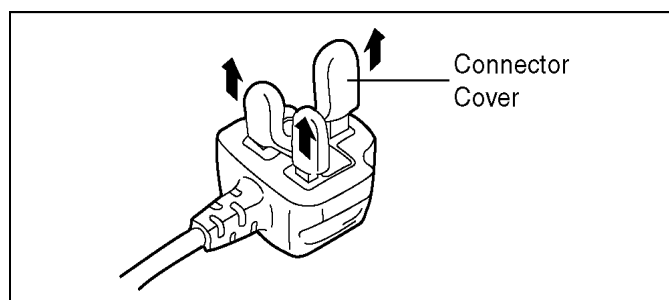

2.3.2.3. How to Replace the Fuse

1. Remove the Fuse Cover with a screwdriver.

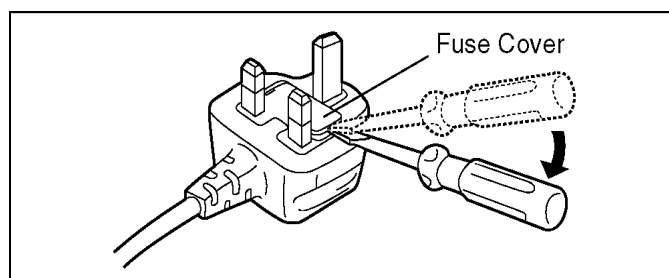

2. Replace the fuse and attach the Fuse cover.

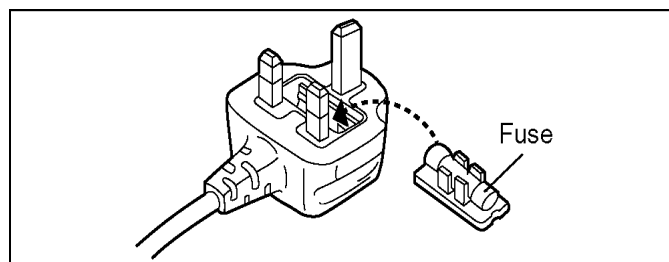

2.4. How to Replace the Lithium Battery

2.4.1. Replacement Procedure

1. Remove the TOP P.C.B.. (Refer to Disassembly Procedures.)
2. Unsolder the each soldering point of electric lead terminal for Lithium battery (Ref. No. "B6301" at foil side of TOP P.C.B.) and remove the Lithium battery together with electric lead terminal. Then replace it into new one.

NOTE:

The Type No. ML421 includes electric lead terminals.

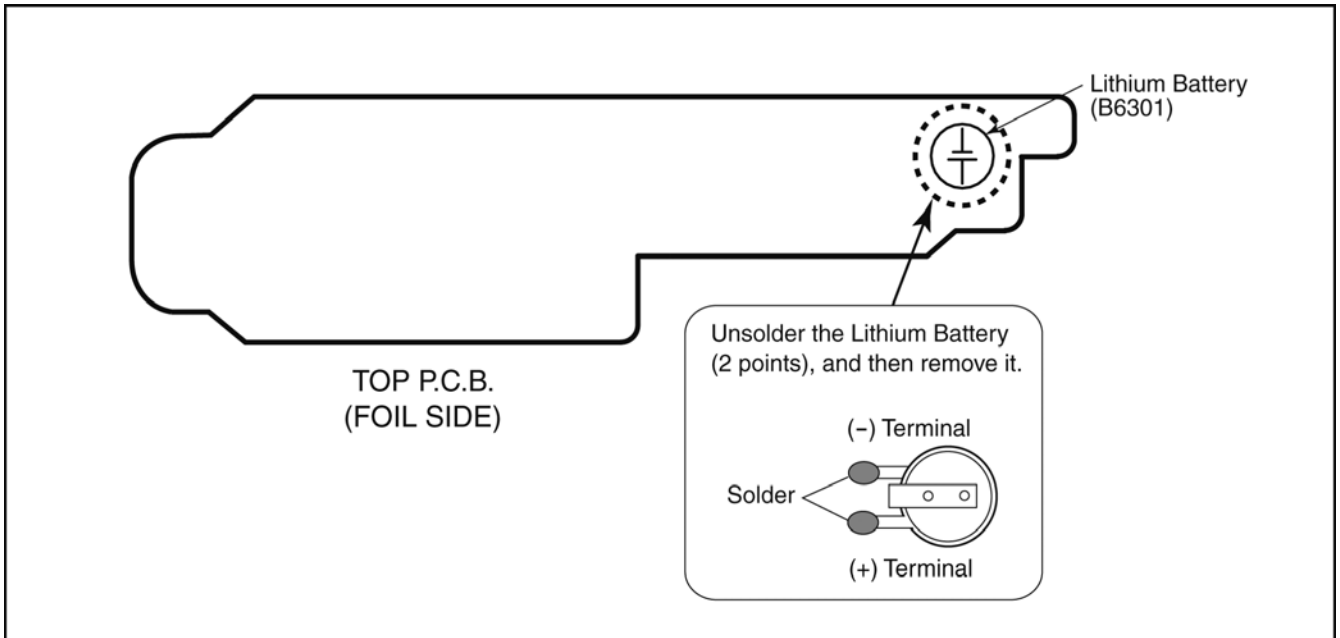

NOTE:

This Lithium battery is a critical component.

(Type No.: ML421 **Manufactured by Energy Company, Panasonic Corporation.**)

It must never be subjected to excessive heat or discharge.

It must therefore only be fitted in requirement designed specifically for its use.

Replacement batteries must be of same type and manufacture.

They must be fitted in the same manner and location as the original battery, with the correct polarity contacts observed.

Do not attempt to re-charge the old battery or re-use it for any other purpose.

It should be disposed of in waste products destined for burial rather than incineration.

(For English)

CAUTION

Danger of explosion if battery is incorrectly replaced.

Replace only with the same or equivalent type recommended by the manufacturer.

Dispose of used batteries according to the manufacturer's instructions.

(For German)

ACHTUNG

Explosionsgefahr bei falschem Anbringen der Batterie. Ersetzen Sie nur mit einem äquivalentem vom Hersteller empfohlenem Typ.

Behandeln Sie gebrauchte Batterien nach den Anweisungen des Herstellers.

(For French)

MISE EN GARDE

Une batterie de remplacement inappropriée peut exploser. Ne remplacez qu'avec une batterie identique ou d'un type recommandé par le fabricant. L'élimination des batteries usées doit être faite conformément aux instructions du fabricant.

NOTE:

Above caution is applicable for a battery pack which is for DMC-S1/S3 series, as well.

3 Service Navigation

3.1. Introduction

This service manual contains technical information, which allow service personnel's to understand and service this model.

Please place orders using the parts list and not the drawing reference numbers.

If the circuit is changed or modified, the information will be followed by service manual to be controlled with original service manual.

3.2. Important Notice (About minimum replacement part size: MAIN P.C.B. & LENS UNIT)

3.2.1. MAIN P.C.B.:

1. The MAIN P.C.B. is handled as the smallest replacement part for this unit.

Therefore if any component on the MAIN P.C.B. is/are defective, replace whole MAIN P.C.B. as a unit.

WHICH P.C.B. IS DEFECTIVE? (MAIN P.C.B. or TOP P.C.B.):

The MAIN P.C.B. and TOP P.C.B. are directly connected with solder, without connector.

The TOP P.C.B. consists of the following component part(s).(All of the signal lines are analogue.)

- *.Power button
- *.Self-timer indicator /AF assist lamp
- *.Shutter button
- *.Back-up battery

When inspecting which PCB is defective, use the "Check terminals" and confirm the each signal.

(From RL6301 to RL6308)

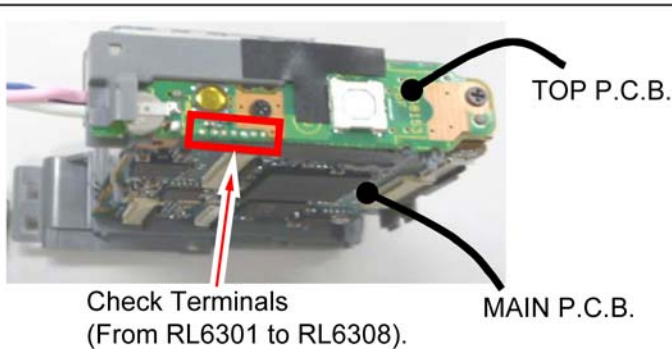

Terminal No.	Terminal Name	Description
RL6301	D_GND	GND
RL6302	SHUTTER_0	Half-shutter (ON :Low)
RL6303	SHUTTER_1	Shutter release (ON :Low)
RL6304	IGBT_VCC	Anode for Self-timer LED.
RL6305	CATHODE	Cathode for Self-timer LED.
RL6306	POWER_ON_L	Power button (ON :Low)
RL6307	CLOCK	Back-up battery
RL6308	D_GND	GND

3.2.2. LENS UNIT:

1. The minimum replacement part size of the Lens part is as shown below.

When servicing, replace the following numbered replacement part size as the smallest size.

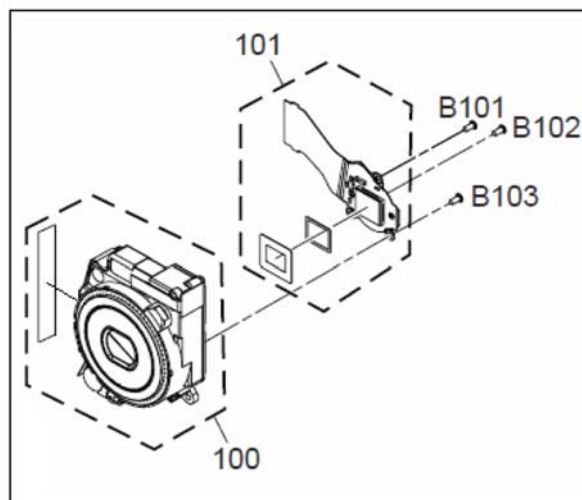

3.2.3. About Flexible Cable and Connector

Do not touch carelessly so that the foreign body should not adhere to the terminal part of flexible cable and connector.

Wipe off with a clean cloth and the cotton bud, etc. when the terminal part is dirty.

3.3. General Description About Lead Free Solder (PbF)

The lead free solder has been used in the mounting process of all electrical components on the printed circuit boards used for this equipment in considering the globally environmental conservation.

The normal solder is the alloy of tin (Sn) and lead (Pb). On the other hand, the lead free solder is the alloy mainly consists of tin (Sn), silver (Ag) and Copper (Cu), and the melting point of the lead free solder is higher approx.30°C (86°F) more than that of the normal solder.

Distinction of P.C.B. Lead Free Solder being used

The letter of "PbF" is printed either foil side or components side on the P.C.B. using the lead free solder.(See right figure)	PbF
--	-----

Service caution for repair work using Lead Free Solder (PbF)

- The lead free solder has to be used when repairing the equipment for which the lead free solder is used.
(Definition: The letter of "PbF" is printed on the P.C.B. using the lead free solder.)
- To put lead free solder, it should be well molten and mixed with the original lead free solder.
- Remove the remaining lead free solder on the P.C.B. cleanly for soldering of the new IC.
- Since the melting point of the lead free solder is higher than that of the normal lead solder, it takes the longer time to melt the lead free solder.
- Use the soldering iron (more than 70W) equipped with the temperature control after setting the temperature at 350±30°C (662±86°F).

Recommended Lead Free Solder (Service Parts Route.)

- The following 3 types of lead free solder are available through the service parts route.
RFKZ03D01KS------(0.3mm 100g Reel)
RFKZ06D01KS------(0.6mm 100g Reel)
RFKZ10D01KS------(1.0mm 100g Reel)

Note

* Ingredient: tin (Sn) 96.5%, silver (Ag) 3.0%, Copper (Cu) 0.5%, Cobalt (Co) / Germanium (Ge) 0.1 to 0.3%

3.4. Important Notice 1:(Other than U.S.A. and Canadian Market)

1. The service manual does not contain the following information because of issues servicing to component level without necessary equipment/facilities.
 - a. Schematic diagram, Block Diagram and P.C.B. layout of MAIN P.C.B..
 - b. Parts list for individual parts for MAIN P.C.B..When a part replacement is required for repairing MAIN P.C.B., replace as an assembled parts. (MAIN P.C.B.)
2. The following category is/are recycle module part. please send it/them to Central Repair Center.
 - MAIN P.C.B. (VEP56128A: DMC-S1 series)
 - MAIN P.C.B. (VEP56128B: DMC-S3 series)

3.5. How to Define the Model Suffix (NTSC or PAL model)









There are nine kinds of DMC-S1 and DMC-S3, regardless of the colours.

- a) DMC-S1 (Japan domestic model)
- b) DMC-S1P/PC, DMC-S3P/PC
- c) DMC-S1EB/EF/EG/EP, DMC-S3EB/EF/EG/EP
- d) DMC-S1EE, DMC-S3EE
- e) DMC-S1GK, DMC-S3GK
- f) DMC-S1GT, DMC-S3GT
- g) DMC-S1GD, DMC-S3GD
- h) DMC-S1GN, DMC-S3GN
- i) DMC-S1PU/PR/GA/GC/GF, S3PU/PR/GA/GC/GF

What is the difference is that the "INITIAL SETTINGS" data which is stored in Flash-ROM mounted on MAIN P.C.B..

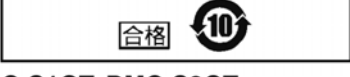
3.5.1. Defining methods:

To define the model suffix to be serviced, refer to the nameplate which is putted on the bottom side of the Unit.

<p>a) DMC-S1 (Japan domestic model) The nameplate for this model shows the following Safety registration mark.</p> 
<p>b) DMC-S1P/PC, DMC-S3P/PC The nameplate for these models show the following Safety registration mark.</p> 
<p>c) DMC-S1EB/EF/EG/EP, DMC-S3EB/EF/EG/EP The nameplate for these models show the following Safety registration mark.</p> 
<p>d) DMC-S1EE, DMC-S3EE The nameplate for these models show the following Safety registration mark.</p> 
<p>e) DMC-S1GK, DMC-S3GK The nameplate for these models show the following Safety registration mark.</p> 
<p>f) DMC-S1GT, DMC-S3GT The nameplate for these models show the following Safety registration mark.</p> 
<p>g) DMC-S1GD, DMC-S3GD The nameplate for these models show the following Safety registration mark.</p> 
<p>h) DMC-S1GN, DMC-S3GN The nameplate for these models show the following Safety registration mark.</p> 
<p>i) DMC-S1PU/PR/GA/GC/GF, DMC-S3PU/PR/GA/GC/GF The nameplate for these models do not show any above Safety registration mark.</p>

NOTE:

After replacing the MAIN P.C.B., be sure to achieve adjustment.

The service software is available at "TSN Website". To download, click on "Support Information from NWBG/VDBG-AVC".

3.5.2. INITIAL SETTINGS:

After replacing the MAIN P.C.B., make sure to perform the initial settings after achieving the adjustment by ordering the following procedure in accordance with model suffix of the unit.

1. IMPORTANT NOTICE:

Before proceeding Initial settings, make sure to read the following CAUTIONS.

CAUTION 1:(INITIAL SETTINGS)

---AFTER REPLACING THE MAIN P.C.B. ---

- *.The model suffix can be chosen **JUST ONE TIME.**
- *.Once one of the model suffix has been chosen, the model suffix lists will not be displayed, thus, it can not be changed.

CAUTION 2:(Stored picture image data in the unit)

This unit employs "Built-in Memory" for picture image data recording.

(DMC-S3: Approx.70MB, DMC-S1: Approx.20MB)

After proceeding "INITIAL SETTINGS", the picture image data stored in the unit is erased.

2. PROCEDURES:

- Precautions: Read the above "CAUTION 1" and "CAUTION 2", carefully.
- Preparation:
 - Attach the Battery or AC Adaptor with a DC coupler to the unit.
(Since this unit has built-in memory, it can be performed without inserting SD memory card.)
 - 1. Turn the Power on.
 - 2. Press the [MODE] button, and select the [NORMAL PICTURE] mode by Cursor buttons, then press the [MENU/SET] button.
 - 3. Turn the Power off.
(If the unit is other than [NORMAL PICTURE] mode, it does not display the initial settings menu.)
- **Step 1. The temporary cancellation of "INITIAL SETTINGS":**
While pressing "[W] side of Zoom button" and "[UP] of Cursor button" simultaneously, turn the Power on.
- **Step 2. The cancellation of "INITIAL SETTINGS":**
Press the [PLAYBACK] button.

While pressing the "[UP] of Cursor button", press and hold the "[W] side of the Zoom button". Release only the "[UP] of Cursor button" once then press the "[UP] of Cursor button" again.

Release the "[W]" and "[UP]" buttons, then turn the Power off.

The LCD displays the " ! " mark before the unit powers down.



- **Step 3. Turn the Power on:**
Turn the Power on.
- **Step 4. Display the INITIAL SETTING:**
While pressing [MENU/SET] button and "[RIGHT] of Cursor button" simultaneously, turn the Power off.
The "INITIAL SETTINGS" menu is displayed.
There are two kinds of "INITIAL SETTINGS" menu form as follows:

[CASE 1. After replacing MAIN P.C.B.]

When MAIN P.C.B. has just been replaced, all of the model suffix is displayed as follows. (Five pages in total)

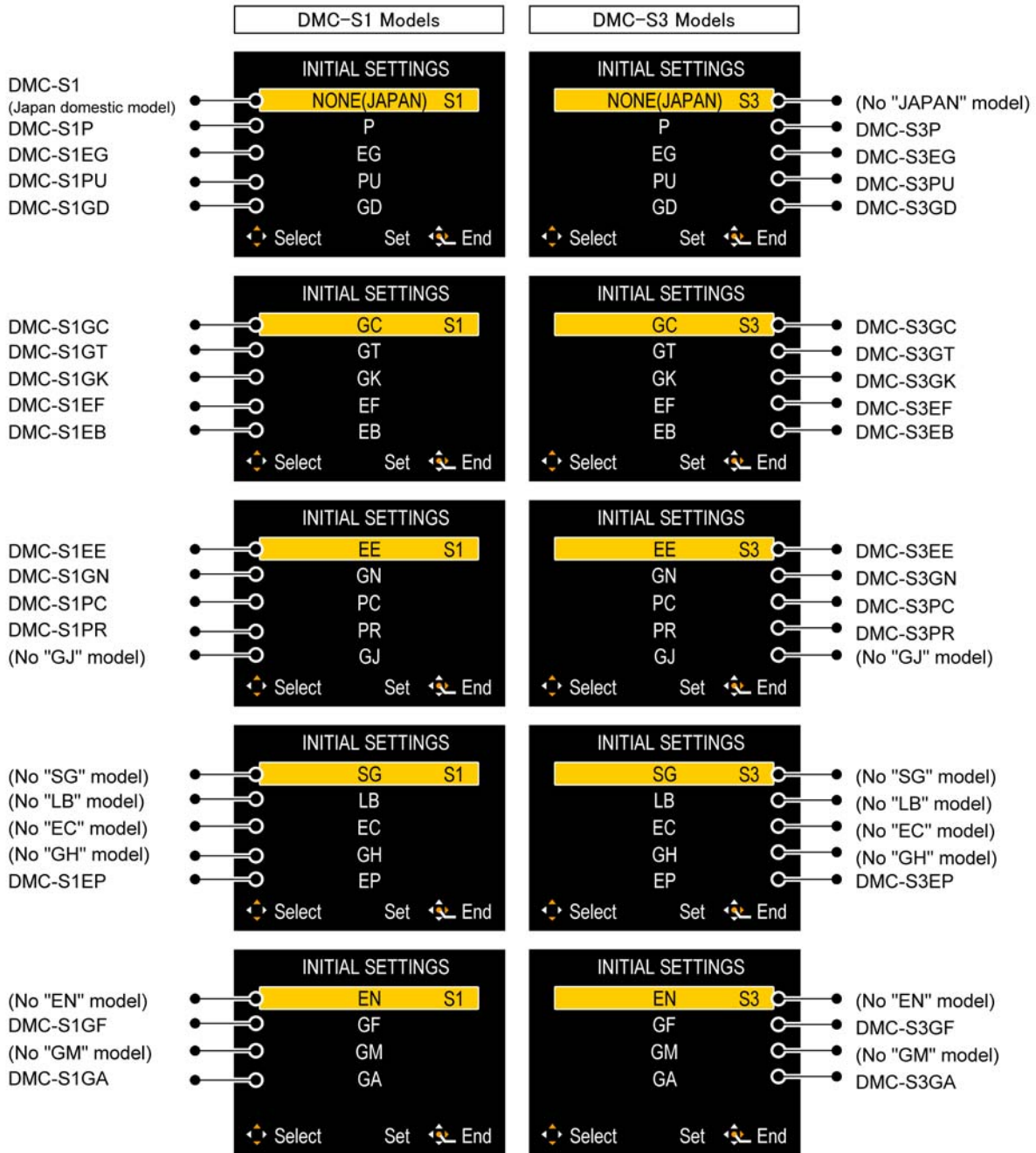

[CASE 2. Other than "After replacing MAIN P.C.B."]

<Other than "EG/EF/EB/EP" models>



<Only "EG/EF/EB/EP" models>

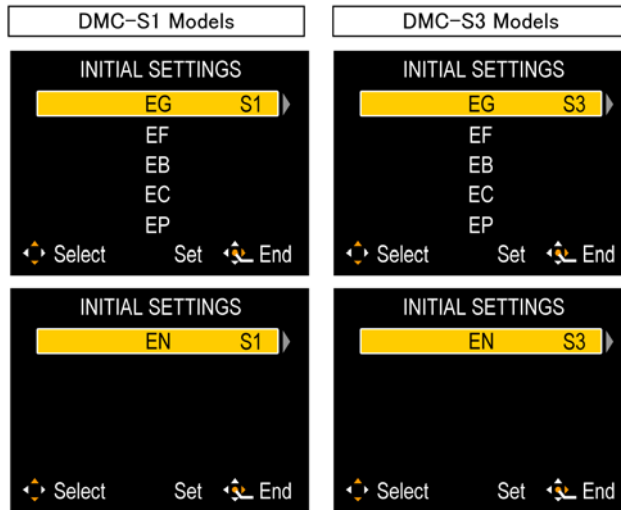

• **Step 5. Choose the model suffix in "INITIAL SETTINGS": (Refer to "CAUTION 1")**

[Caution: After replacing MAIN P.C.B.]

The model suffix can be chosen, **JUST ONE TIME**.

Once one of the model suffix have been chosen, the model suffix lists will not be displayed, thus, it can not be changed.

Therefore, select the area carefully.

Select the area with pressing "[UP] / [DOWN] of Cursor buttons".

• **Step 6. Set the model suffix in "INITIAL SETTINGS":**

Press the "[RIGHT] of Cursor buttons".

The only set area is displayed, and then press the "[RIGHT] of Cursor buttons" after confirmation.

(The unit is powered off automatically.)

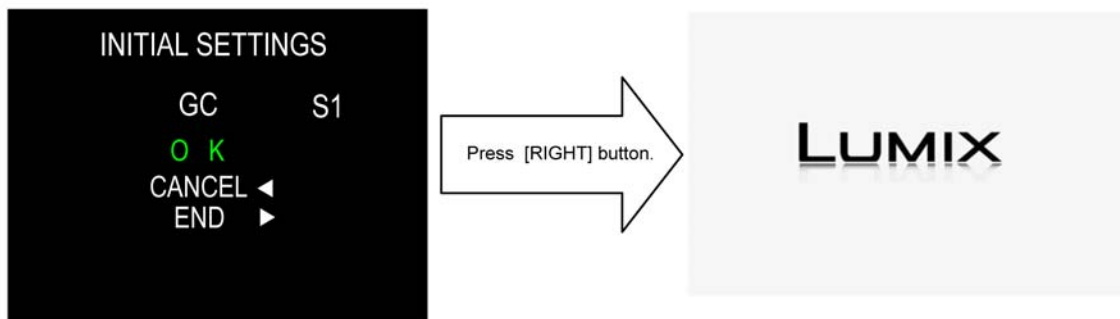

• **Step 7. CONFIRMATION:**

Confirm the display of “PLEASE SET THE CLOCK” in concerned language when the unit is turned on again.

When the unit is connected to PC with USB cable, it is detected as removable media.

(When the “GT” or “GK” model suffix is selected, the display shows “PLEASE SET THE CLOCK” in Chinese.)

1) As for your reference, major default setting condition is as shown in the following table.

• **Default setting (After “INITIAL SETTINGS”)**

	MODEL	VIDEO OUTPUT	LANGUAGE	DATE	REMARKS
a)	DMC-S1(Japan domestic model)	NTSC	Japanese	Year/Month/Date	
b)	DMC-S1P/S3P	NTSC	English	Month/Date/Year	
c)	DMC-S1PC/S3PC	NTSC	English	Month/Date/Year	
d)	DMC-S1PU/S3PU	NTSC	Spanish	Month/Date/Year	
e)	DMC-S1PR/S3PR	NTSC	Spanish	Month/Date/Year	
f)	DMC-S1EG/S3EG	PAL	English	Date/Month/Year	
g)	DMC-S1EP/S3EP	PAL	English	Date/Month/Year	
h)	DMC-S1EF/S3EF	PAL	French	Date/Month/Year	
i)	DMC-S1EB/S3EB	PAL	English	Date/Month/Year	
j)	DMC-S1EE/S3EE	PAL	Russian	Date/Month/Year	
k)	DMC-S1GC/S3GC	PAL	English	Date/Month/Year	
l)	DMC-S1GF/S3GF	PAL	English	Date/Month/Year	
m)	DMC-S1GA/S3GA	PAL	English	Date/Month/Year	
n)	DMC-S1GT/S3GT	NTSC	Chinese (traditional)	Year/Month/Date	
o)	DMC-S1GK/S3GK	PAL	Chinese (simplified)	Year/Month/Date	
p)	DMC-S1GN/S3GN	PAL	English	Date/Month/Year	
q)	DMC-S1GD/S3GD	NTSC	Korean	Year/Month/Date	

4 Specifications

Digital Camera: Information for your safety

Power Source	DC 5.1 V
Power Consumption	When recording: 1.2 W When playing back: 0.7 W
Camera effective pixels	14,100,000 pixels (DMC-S3) 12,100,000 pixels (DMC-S1)
Image sensor	1/2.33" CCD, total pixel number 14,500,000 pixels (DMC-S3) 12,700,000 pixels (DMC-S1) Primary color filter
Lens	Optical 4 x zoom f=5.0 mm to 20.0 mm (35 mm film camera equivalent: 28 mm to 112 mm)/ F3.1 (Max. W) to F6.5 (Max. T)
Digital Zoom	Max. 4 x
Extended Optical Zoom	Max. 8.4 x (DMC-S3) Max. 7.8 x (DMC-S1) (When the picture size is set to 3 million pixels [3M] or less.)
Focus range	
Intelligent Auto/Normal/Motion Picture	5 cm (0.17 feet) (Wide)/1 m (3.28 feet) (Tele) to ∞
Scene Mode	There may be difference in above settings.
Shutter system	Electronic shutter + Mechanical shutter
Burst recording	
Burst speed	2 pictures/second (DMC-S3) The burst speed differs according to the writing speed of the card and picture size. (DMC-S1)
Number of recordable pictures	Until card/built-in memory is full
Shutter speed	8 to 1/1600 th
Exposure (AE)	AUTO (Program AE) Exposure Compensation (1/3 EV Step, -2 EV to +2 EV)
Metering Mode	Multiple
LCD monitor	2.7" TFT LCD (4:3) (Approx. 230,400 dots) (field of view ratio about 100 %)
Flash	Flash range: (ISO  ISO) Approx. 40 cm (1.32 feet) to 3.3 m (10.8 feet) (Wide)
Microphone	Monaural
Speaker	Monaural
Recording media	Built-in Memory (DMC-S3: Approx. 70 MB, DMC-S1: Approx. 20 MB)/ SD Memory Card/SDHC Memory Card/ SDXC Memory Card

Recording file format	
Still picture	JPEG (based on Design rule for Camera File system, based on Exif 2.3 standard)
Motion pictures	QuickTime Motion JPEG (motion pictures with audio)
Interface	
Digital	USB 2.0 (High Speed)
Analog video	[for NTSC areas] NTSC [for PAL areas] NTSC/PAL Composite (Switched by menu)
Audio	Audio line output (Monaural)
Terminal	AV OUT/DIGITAL: Dedicated jack (8 pin)
Dimensions	Approx. 98.8 mm (W) x 58.8 mm (H) x 20.9 mm (D) [3.89" (W) x 2.31" (H) x 0.82" (D)] (excluding the projection part)
Mass	With card and battery: Approx. 117 g (0.26 lb) Excluding card and battery: Approx. 100 g (0.22 lb)
Operating temperature	0 °C to 40 °C (32 °F to 104 °F)
Operating humidity	10 %RH to 80 %RH

Battery charger: Information for your safety

Input	110 V to 240 V ~ 50/60Hz, 0.2 A
Output	4.2 V = 0.43 A (Battery charging)

Equipment mobility: Movable

Battery pack (lithium-ion): Information for your safety

Voltage/capacity	3.6 V / 660 mAh
-------------------------	-----------------

NOTE:(Only for "EB/EF/EG/EP/PR" models)

- Data from the PC can not be written to the camera using the USB connection cable.
- Motion pictures can be recorded continuously for up to 15 minutes.

5 Location of Controls and Components

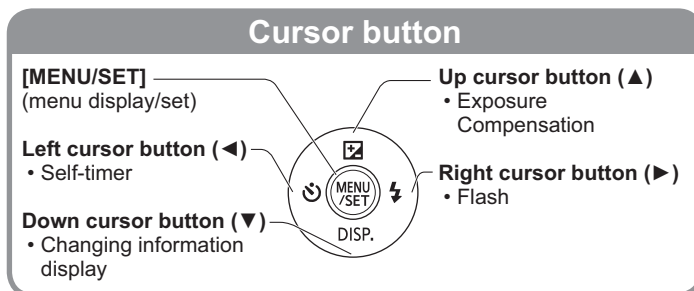
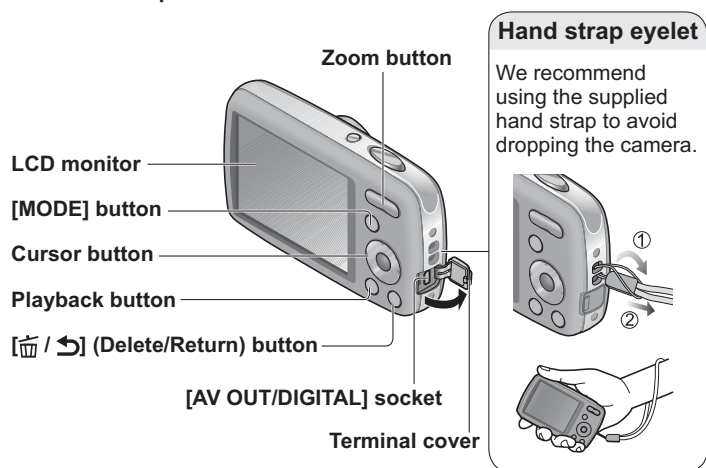
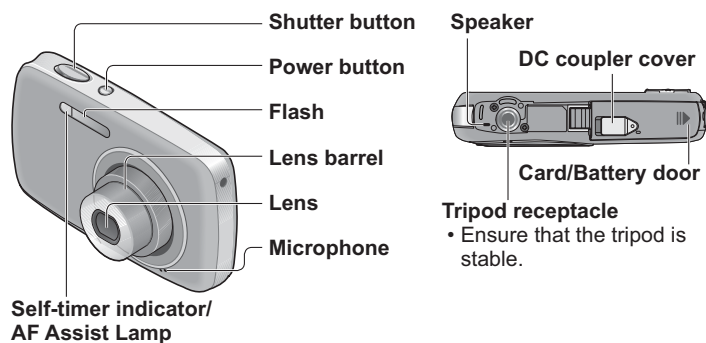



- Always use a genuine Panasonic AC adaptor (optional).
- When using an AC adaptor, ensure that the Panasonic DC coupler (optional) and AC adaptor (optional) are used.
- If the power supply is cut off due to a power cut or the AC adaptor being disconnected, the motion picture being recorded using the AC adaptor will not be recorded.
- Some tripods or unipods, and some methods of holding the camera may block the speaker, making it difficult to hear the beep, etc.

Selecting the Recording Mode

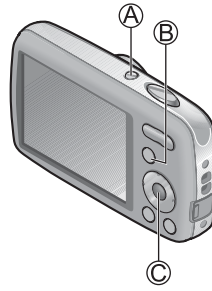
- 1 Press the Power button (A)**
The power is turned on.
- 2 Press the [MODE] button (B)**
- 3 Press ▲▼◀▶ to select the Recording Mode**
- 4 Press [MENU/SET] (C)**



 IA	[Intelligent Auto] Mode Taking pictures with automatic settings.
	[Normal Picture] Mode Take pictures with your own settings.
SCN	[Scene Mode] Take pictures according to scene.
	[Motion Picture] Mode Take motion pictures.

About the Battery

- The camera has a function for distinguishing batteries which can be used safely. The dedicated battery supports this function. The only batteries suitable for use with this unit are genuine Panasonic products and batteries manufactured by other companies and certified by Panasonic. (Batteries which do not support this function cannot be used). Panasonic cannot in any way guarantee the quality, performance or safety of batteries which have been manufactured by other companies and are not genuine Panasonic products.

It has been found that counterfeit battery packs which look very similar to the genuine product are made available to purchase in some markets. Some of these battery packs are not adequately protected with internal protection to meet the requirements of appropriate safety standards. There is a possibility that these battery packs may lead to fire or explosion. Please be advised that we are not liable for any accident or failure occurring as a result of use of a counterfeit battery pack. To ensure that safe products are used we would recommend that a genuine Panasonic battery pack is used.

6 Service Mode

6.1. Error Code Memory Function

1. General description

This unit is equipped with history of error code memory function, and can be memorized 16 error codes in sequence from the latest. When the error is occurred more than 16, the oldest error is overwritten in sequence.

The error code is not memorized when the power supply is shut down forcibly (i.e., when the unit is powered on by the battery, the battery is pulled out) The error code is memorized to FLASH-ROM when the unit has just before powered off.

2. How to display

The error code can be displayed by ordering the following procedure:

• Preparation:

1. Attach the Battery or AC Adaptor with a DC coupler to the unit.

NOTE:

*Since this unit has built-in memory, it can be performed without inserting SD memory card.

2. Turn the Power on.

3. Press the [MODE] button, and select the [NORMAL PICTURE] mode by Cursor buttons, then press the [MENU/SET] button.

• Step 1. The temporary cancellation of "INITIAL SETTINGS":

While pressing "[W] side of Zoom button" and "[UP] of Cursor button" simultaneously, turn the power on.

• Step 2. Execute the error code display mode:

While pressing the "[W] side of the Zoom button", press the "[LEFT] of Cursor button" and the "[MENU/SET] button" simultaneously.

Every time when performing above operation, the display is changed as shown below.

Normal display → Error code display → Operation history display → Normal display →.....

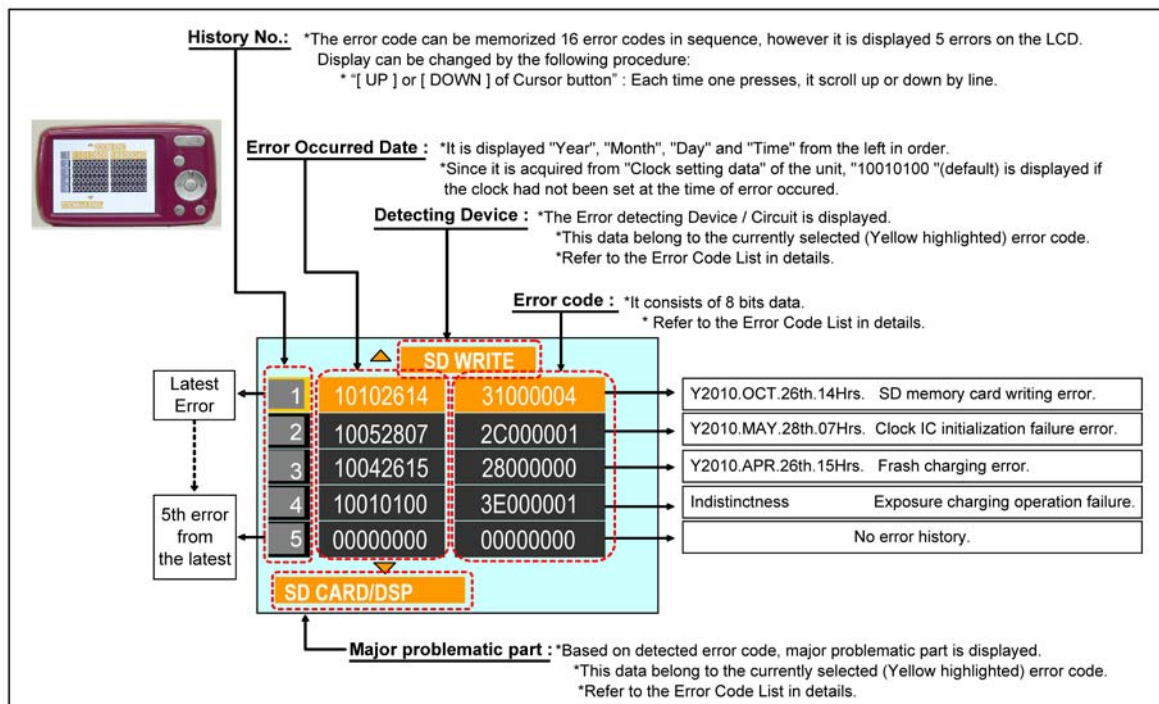

Example of Error Code Display

• 3. Error Code List

The error code consists of 8 bits data and it shows the following information.

Attribute	Main item	Sub item	Error code		Contents (Upper line)		Error Indication		
			High 4 bits	Low 4 bits	Problematic Part & Check point (Lower line)		Detecting device	Problematic Part/Circuit	
LENS	Lens drive	OIS	18*0	1000	PSD (X) error. Hall element (X axis) position detect error in OIS unit. Lens Unit.	OIS X	LENSu NG		
				2000	PSD (Y) error. Hall element (Y axis) position detect error in OIS unit. Lens Unit.	OIS Y			
				3000	GYRO (X) error. Main P.C.B..	GYRO X	GYRO NG		
				4000	GYRO (Y) error. Main P.C.B..	GYRO Y			
				5000	MREF error (Reference voltage error). Main P.C.B..	OIS REF	LENSSd/DSP NG		
				6000	Drive voltage (X) error. LENS Unit, LENS flex breaks, etc.	OISX REF	LENSu/LENS FPC		
				7000	Drive voltage (Y) error. LENS Unit, LENS flex breaks, etc.	OISY REF			
		Zoom	0710	Collapsible barrel Low detect error (Collapsible barrel encoder always detects Low.) Lens Unit, Main P.C.B..	ZOOM L	ZOOMm/LENSu			
				0720	Collapsible barrel High detect error (Collapsible barrel encoder always detects High.) Lens Unit, Main P.C.B..		ZOOM H		
		Focus	0701	HP High detect error (Focus encoder always detects High, and not becomes Low) Lens Unit, Main P.C.B..	FOCUS L	LENS FPC/DSP			
				0702	HP Low detect error (Focus encoder always detects Low, and not becomes High) Lens Unit, Main P.C.B..		FOCUS H		
		Lens	18*1	0000	Power ON time out error. Lens Unit, Main P.C.B..	LENS DRV	LENSu		
				0000	Power OFF time out error. Lens Unit, Main P.C.B..				
		Adj. History	OIS	19*0	2000	OIS adj. Yaw direction amplitude error (small)	OIS ADJ	OIS ADJ	
	3000				OIS adj. Pitch direction amplitude error (small)				
	4000				OIS adj. Yaw direction amplitude error (large)				
	5000				OIS adj. Pitch direction amplitude error (large)				
	6000				OIS adj. MREF error				
	7000				OIS adj. time out error				
	8000				OIS adj. Yaw direction off set error				
	9000				OIS adj. Pitch direction off set error				
A000	OIS adj. Yaw direction gain error								
B000	OIS adj. Pitch direction gain error								
C000	OIS adj. Yaw direction position sensor error								
D000	OIS adj. Pitch direction position sensor error								
E000	OIS adj. other error								
HARD	VENUS A/D				Flash	28*0			0000
	FLASH ROM (EEPROM Area)	FLASH ROM (EEPROM Area)	2B*0	0001	EEPROM read error Main P.C.B..	FROM RE	FROM		
				0002	EEPROM write error Main P.C.B..	FROM WR	FROM		
				0005	Firmware version up error Replace the firmware file in the SD memory card.	(No indication)	(No indication)		
				0008 0009	SDRAM error SDRAM Mounting defective				
	SYSTEM	RTC	2C*0	0001	SYSTEM IC initialize failure error Main P.C.B..	SYS INIT	MAIN PCB		
	SOFT	CPU	Reset	30*0	0001	NMI reset Non Mask-able Interrupt (30000001-30000007 are caused by factors)	NMI RST	MAIN PCB	
Card					Card	31*0	0001	Card logic error SD Memory card, Main P.C.B..	SD CARD
		0002	Card physical error SD Memory card, Main P.C.B..						
		0004	Write error SD Memory card, Main P.C.B..	SD WRITE					
CPU, ASIC hard		Stop	38*0	0001	Camera task finish process time out. Lens Unit, Main P.C.B..	LENS COM	LENSu/DSP		
					0002	Camera task invalid code error. Main P.C.B..	DSP	DSP	
					0100	File time out error in recording motion image Main P.C.B..			
					0200	File data cue send error in recording motion image Main P.C.B..			
					0300	Single or burst recording brake time out.			
Memory area		3A*0	0008	USB work area partitioning failure USB cable, Main P.C.B..	(No indication)	(No indication)			
			Operation	Power on	3B*0	0000	FLASHROM processing early period of camera during movement.	INIT	(No indication)
Zoom		Zoom	3C*0	0000	Inperfect zoom lens processing Lens Unit.	ZOOM	ZOOMm/LENSu		
					35*0	0000	Software error (0-7bit : command, 8-15bit : status)	DSP	DSP
						FFFF			
	35*1				0000	Though record preprocessing is necessary, it is not called.			
35*2	0000	Though record preprocessing is necessary, it is not completed.	(No indication)	(No indication)					

Important notice about "Error Code List"

1) About "*" indication:

The third digit from the left is different as follows.

- In case of 0 (example: 18001000)

When the third digit from the left shows "0", this error occurred under the condition of INITIAL SETTINGS has been completed.

It means that this error is occurred basically at user side.

- In case of 8 (example: 18801000)

When the third digit from the left shows "8", this error occurred under the condition of INITIAL SETTINGS has been released.

(Example; Factory assembling-line before unit shipment, Service mode etc.)

It means that this error is occurred at service side.

2) About "?" indication: ("18*0 0?01" to "18*0 0?50"):

The third digit from the right shows one of the hexadecimal ("0" to "F") character.

• 4. How to exit from Error Code display mode:

Simply, turn the power off. (Since Error code display mode is executed under the condition of temporary cancellation of "INITIAL SETTINGS", it wake up with normal condition when turn off the power.)



NOTE:

The error code can not be initialized.

7 Service Fixture & Tools

7.1. Service Fixture and Tools

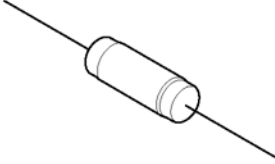
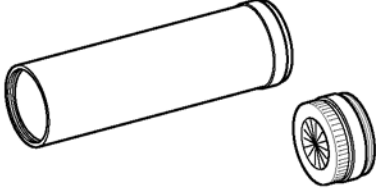
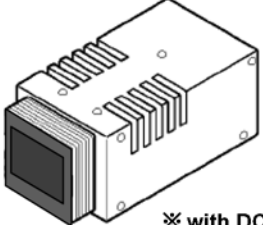
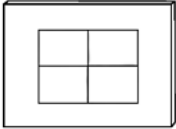
The following Service Fixture and tools are used for checking and servicing this unit.

Resistor for Discharging ERG5SJ102	Infinity Lens (with Focus Chart) VFK1164TCM02	LIGHT BOX RFKZ0523
 <p>An equivalent type of Resistor may be used.</p>	 <p>* VFK1164TCM03 can be used. * RFKZ0422 can be used.</p>	 <p>※ with DC Cable * VFK1164TDVLB can be used.</p>
TR Chart RFKZ0443	Lens Cleaning Kit (BK) VFK1900BK	ND Filter (ND1.5) VFK1164ND15
	 <p>* Only supplied as 10 set/box.</p>	

7.2. When Replacing the Main P.C.B.

After replacing the MAIN P.C.B., be sure to achieve adjustment.

The service software is available at "TSN Website". To download, click on "Support Information from NWBG/VDBG-AVC".

8 Disassembly and Assembly Instructions

8.1. Disassembly Flow Chart

This is a disassembling chart.

When assembling, perform this chart conversely.

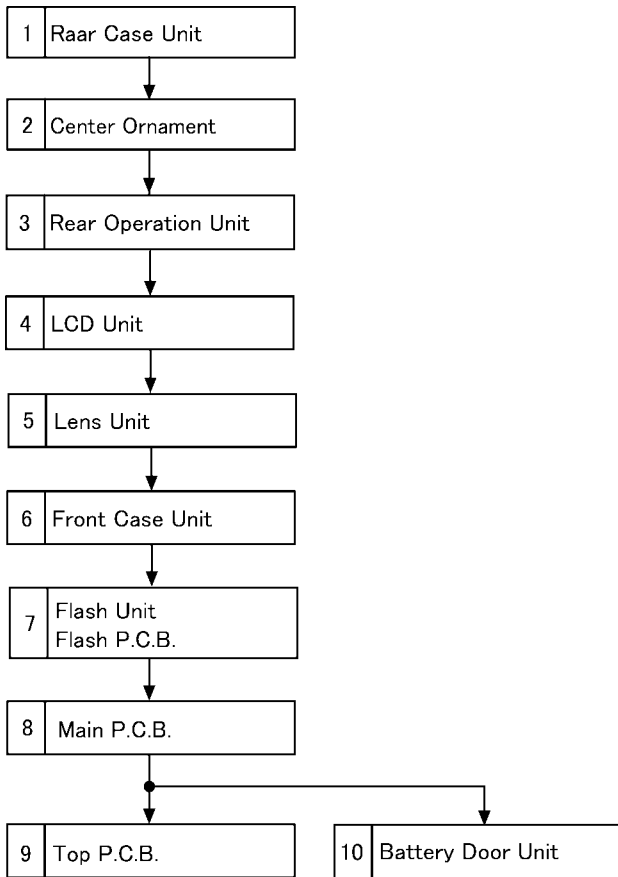

8.2. P.C.B. Location

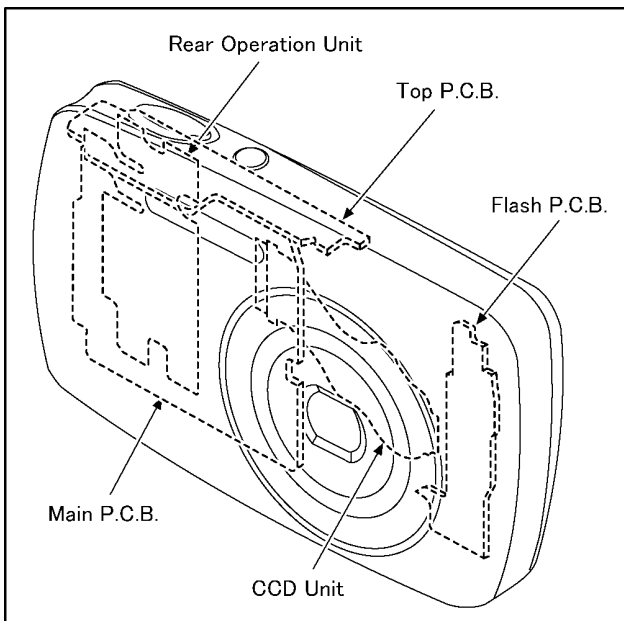

8.3. Disassembly Procedure

No.	Item	Fig	Removal
1	Rear Case Unit	(Fig. D1)	Card
			Battery
		(Fig. D2)	3 Screws (A)
			1 Screw (B)
			3 Locking tabs
2	Center Ornament	(Fig. D3)	Operation Button
			Rear Case Unit
3	Rear Operation Unit	(Fig. D4)	3 Locking tabs
			Center Ornament
			1 Screw (C)
			1 Locking tab
			1 Projection part
4	LCD Unit	(Fig. D5)	Connector(A)
			Rear Operation Unit
			2 Locking tabs
			Connector(B)
5	Lens Unit	(Fig. D6)	LCD Unit
			1 Screw (D)
			1 Screw (E)
			2 Locking tabs
			Frame Plate A
			Connector(C)
			Connector(D)
Connector(E)			
6	Front Case Unit	(Fig. D7)	Lens Unit
			5 Locking tabs
			Jack Cover
			Front Case Unit
7	Flash Unit Flash P.C.B.	(Fig. D8)	1 Locking tab
			FP8001 (Flex)
			Mic
		(Fig. D9)	2 Locking tabs
			Flash Unit
8	Main P.C.B.	(Fig. D10)	Flash P.C.B.
			Solder (11 points)
			2 Screws (F)
			Main P.C.B.
9	Top P.C.B.	(Fig. D11)	2 Screws (G)
			2 Projection parts
			Top P.C.B.
10	Battery Door Unit	(Fig. D12)	Battery Door Shaft
			Battery Door Unit

8.3.1. Removal of the Rear Case Unit

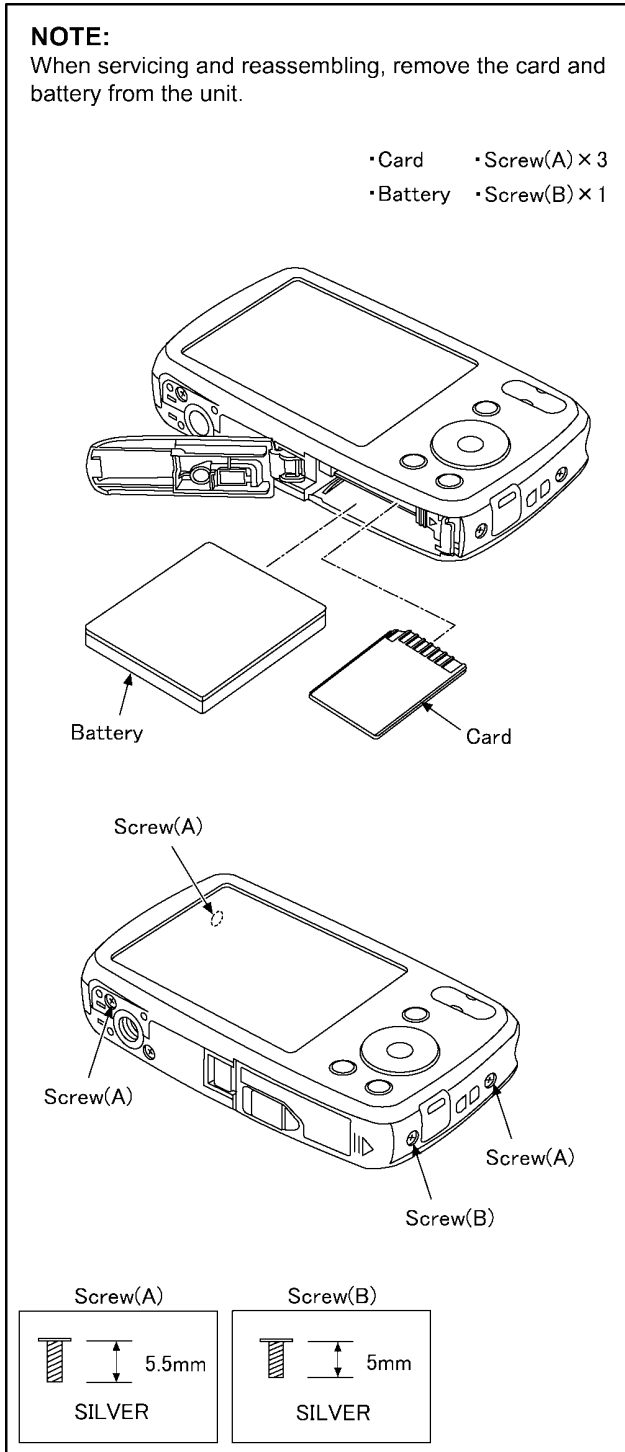

(Fig. D1)

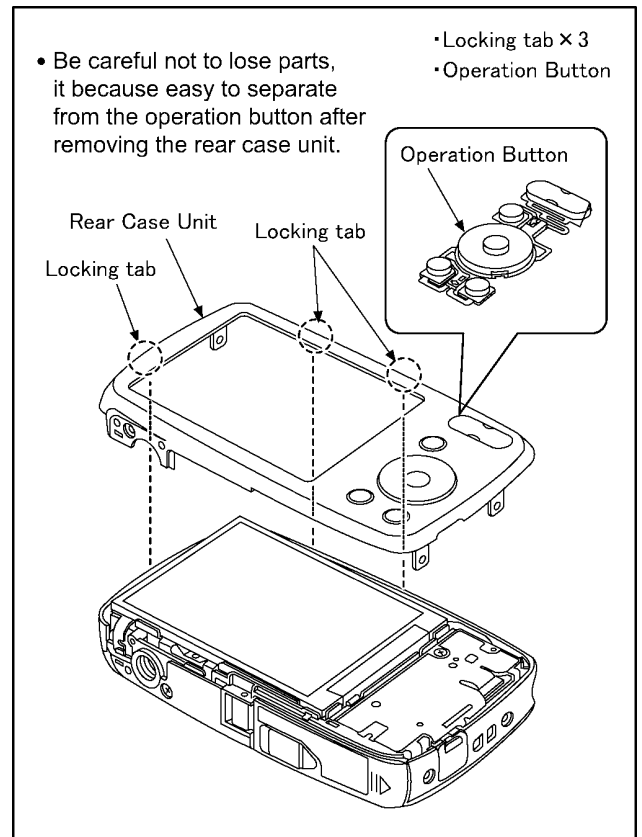

(Fig. D2)

8.3.2. Removal of the Center Ornament

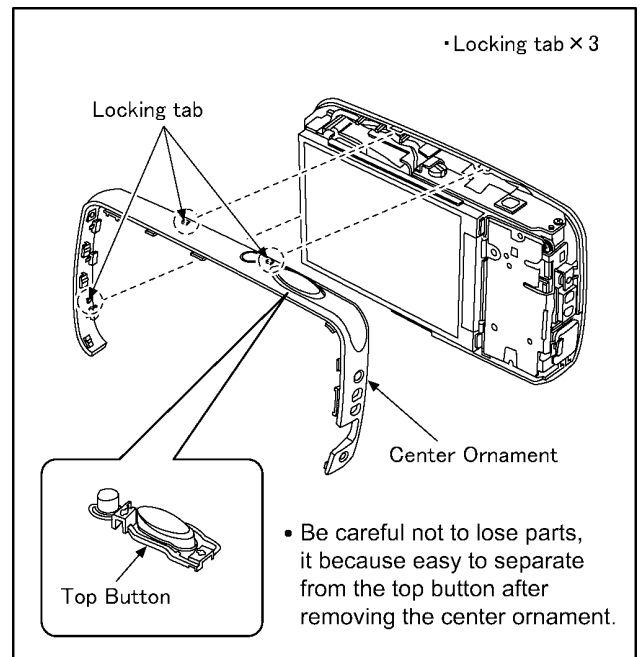

(Fig. D3)

8.3.3. Removal of the Rear Operation Unit

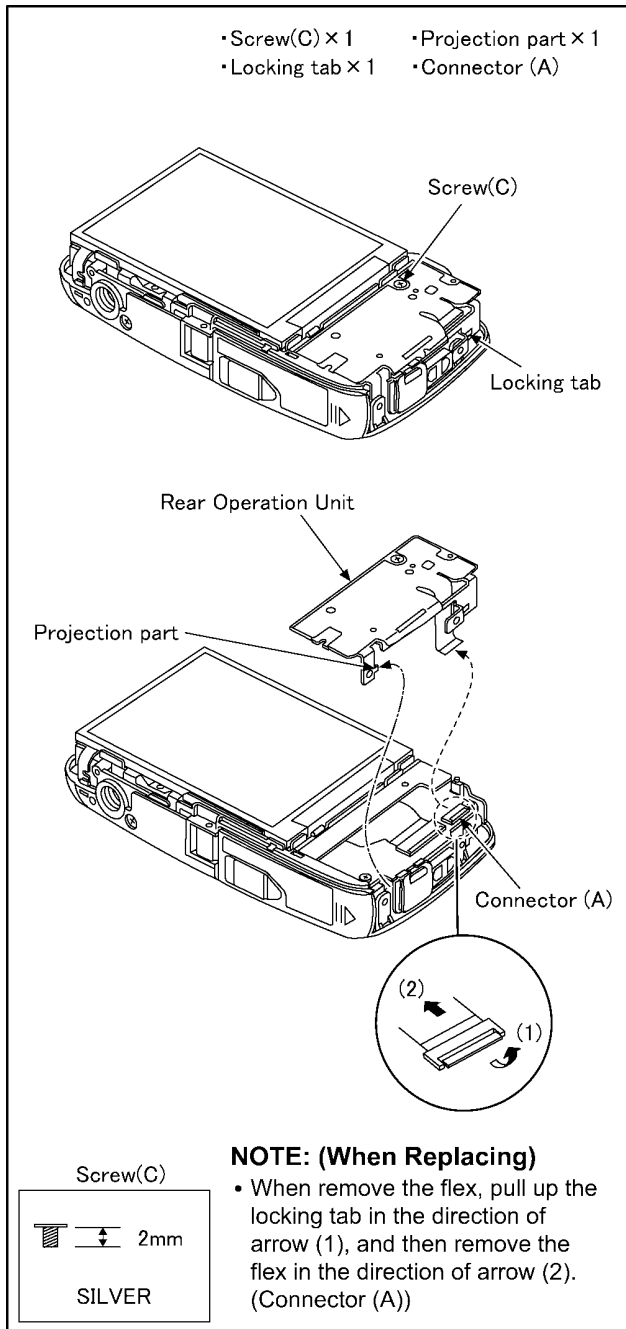

(Fig. D4)

8.3.4. Removal of the LCD Unit

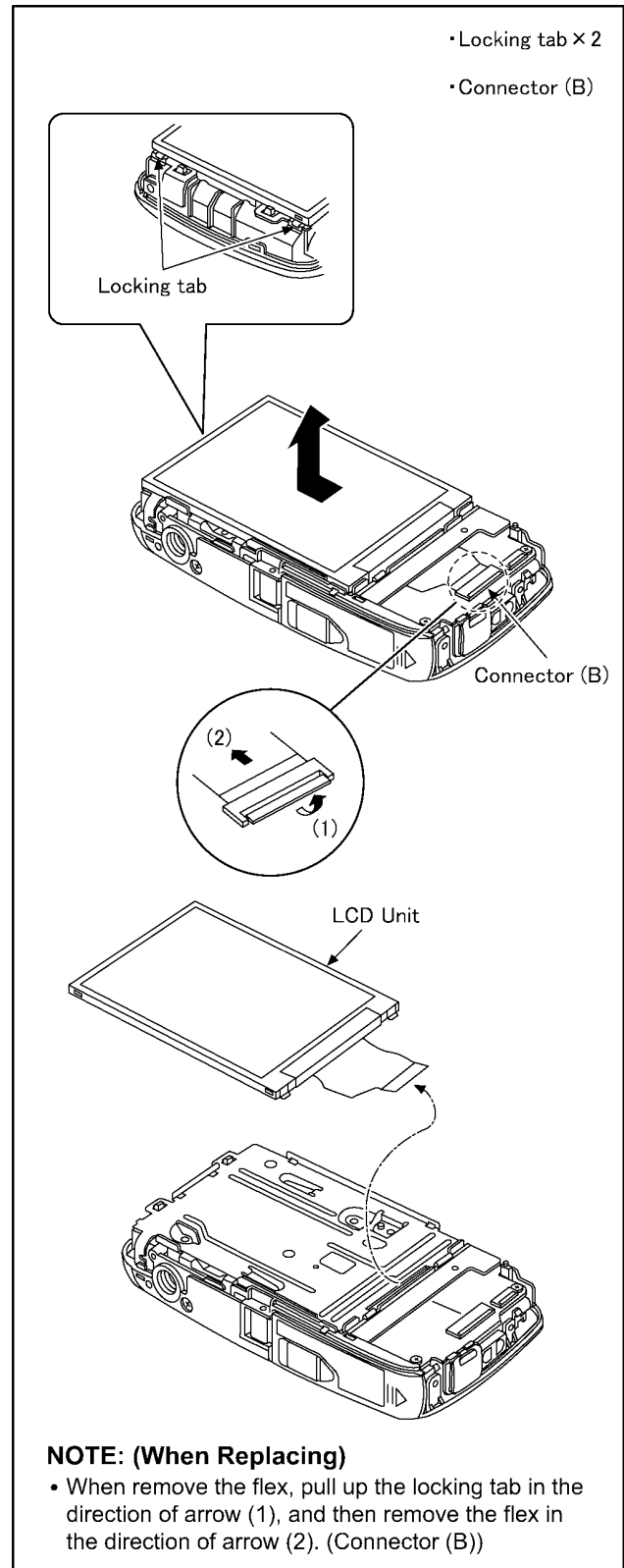

(Fig. D5)

8.3.5. Removal of the Lens Unit

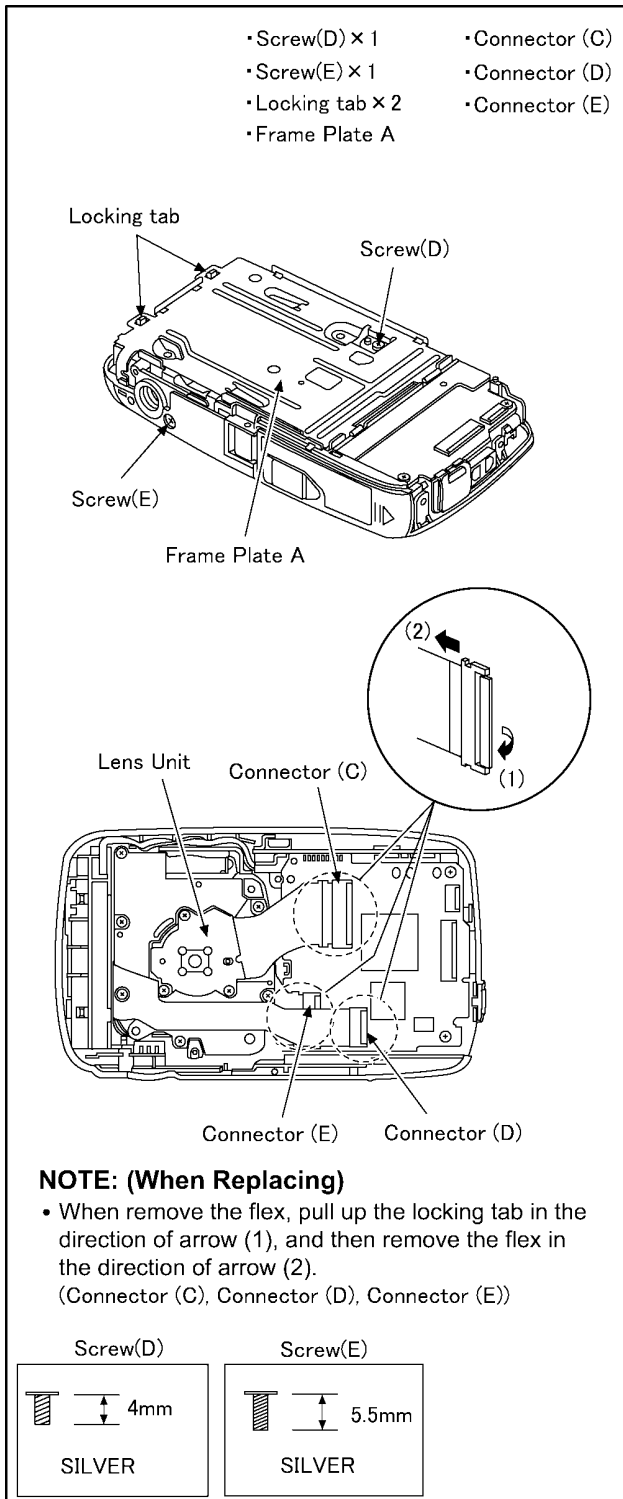

(Fig. D6)

8.3.6. Removal of the Front Case Unit

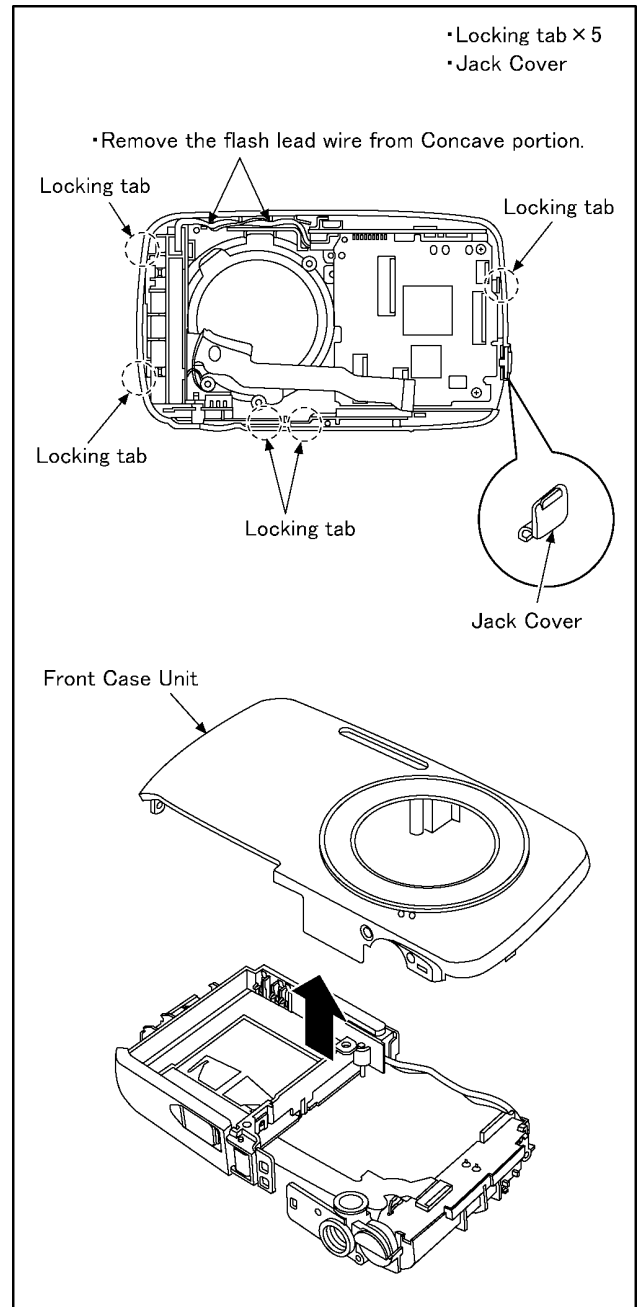

(Fig. D7)

8.3.7. Removal of the Flash Unit and Flash P.C.B.

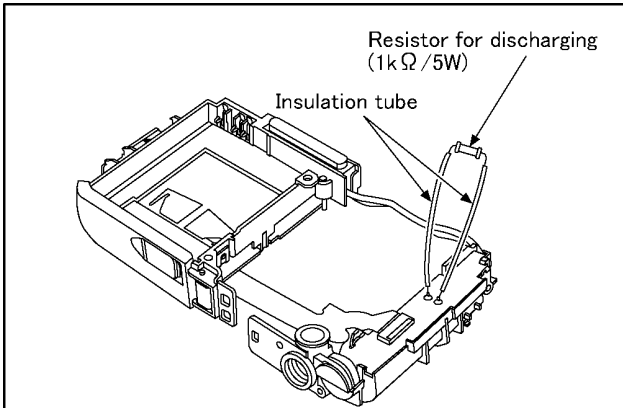

CAUTION

Be sure to discharge the E.capacitor on Flash P.C.B. before disassembling.

1. Put the insulation tube on the lead part of resistor (ERG5SJ102: 1kΩ/5W).
2. Put the resistor between both terminals of capacitor unit for approx. 5 seconds.

IMPORTANT NOTICE:

Take care not apply any bending load to the charging capacitor. It brings about the possibility of P.C.B. and/or component damage on the Flash P.C.B..

- Locking tab × 1
- Mic
- FP8001 (Flex)

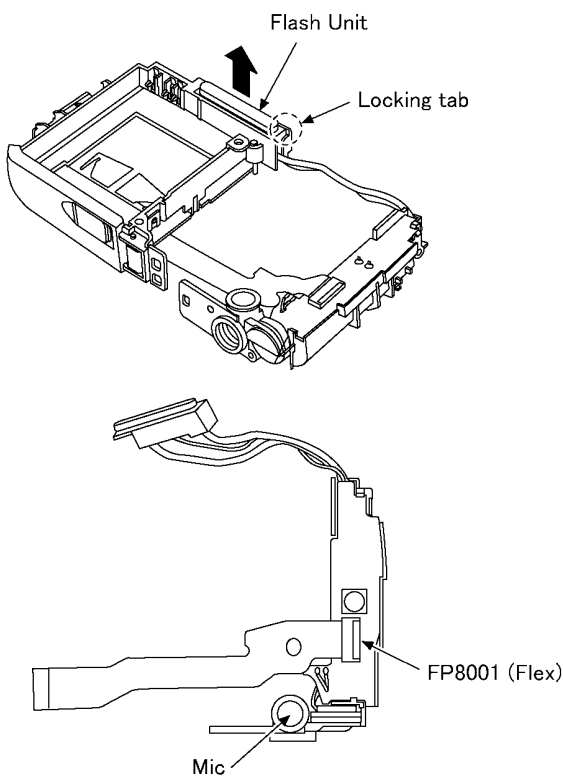

(Fig. D8)

IMPORTANT NOTICE:

Take care not apply any bending load to the charging capacitor. It brings about the possibility of P.C.B. and/or component damage on the Flash P.C.B..

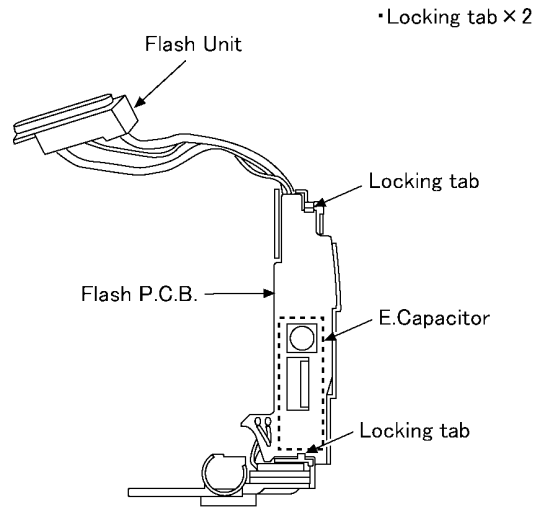

(Fig. D9)

8.3.8. Removal of the Main P.C.B.

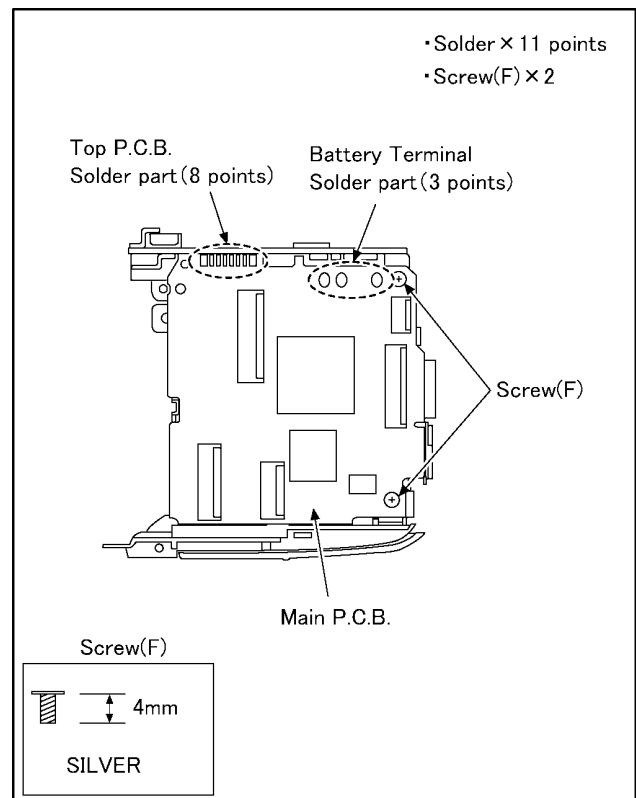

(Fig. D10)

[WHEN ASSEMBLING]

CAUTION: Before soldering the Terminal A (Connecting part of Main P.C.B. and Top P.C.B.)

Before soldering the Terminal A, make sure to tighten the "Screw (D)" first in order to eliminate the gap between Main P.C.B. and Battery Frame. Otherwise, soldered terminal A part may be damaged after assembling.

NOTE:

Since the screw (D) is for fixing the frame plate A, the screw (D) has to be removed once, after soldering.

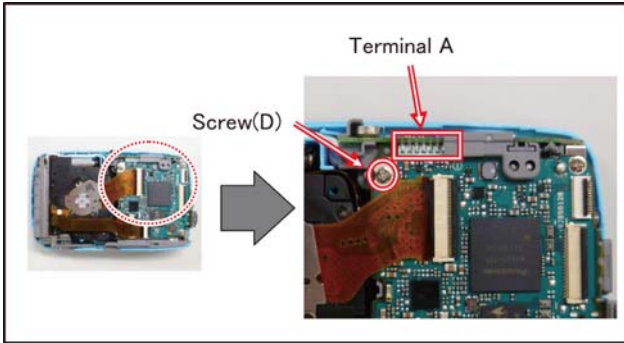

8.3.9. Removal of the Top P.C.B.

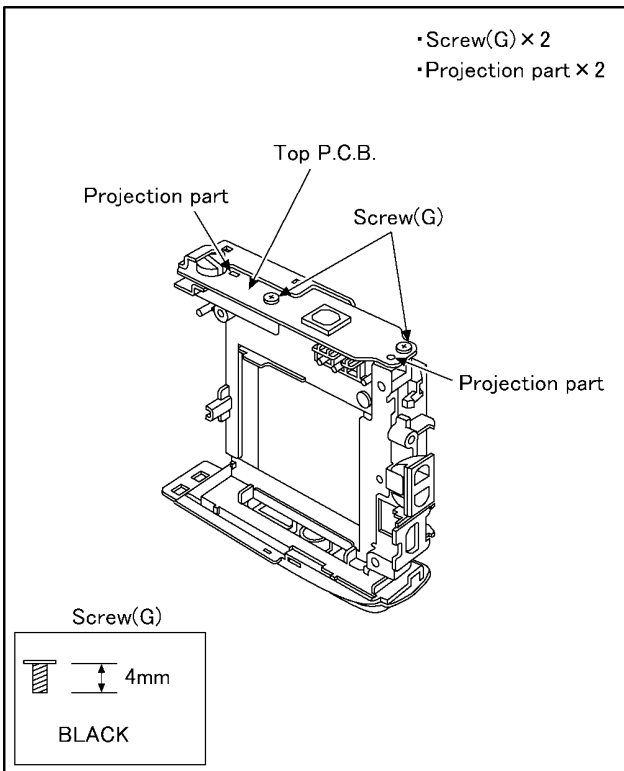

(Fig. D11)

8.3.10. Removal of the Battery Door Unit

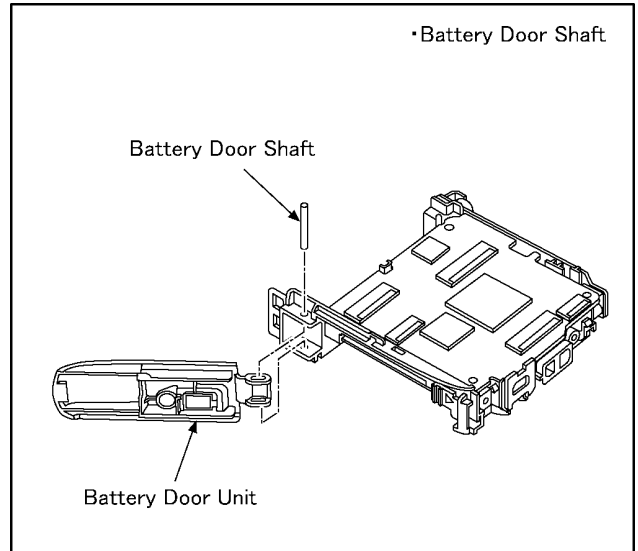

(Fig. D12)

NOTE: (When Installing)

Make sure to confirm the following points when installing:

- The Screw is tightened enough.
- Installing conditions are fine. (No distortion, no abnormal-space.)
- No dust and/or dirt on Lens surfaces.
- LCD image is fine. (No dust and dirt on it, and no gradient images.)

8.4. Removal of the CCD Unit

To prevent the CCD unit from catching the dust and dirt, do not remove the CCD unit except for replacing.

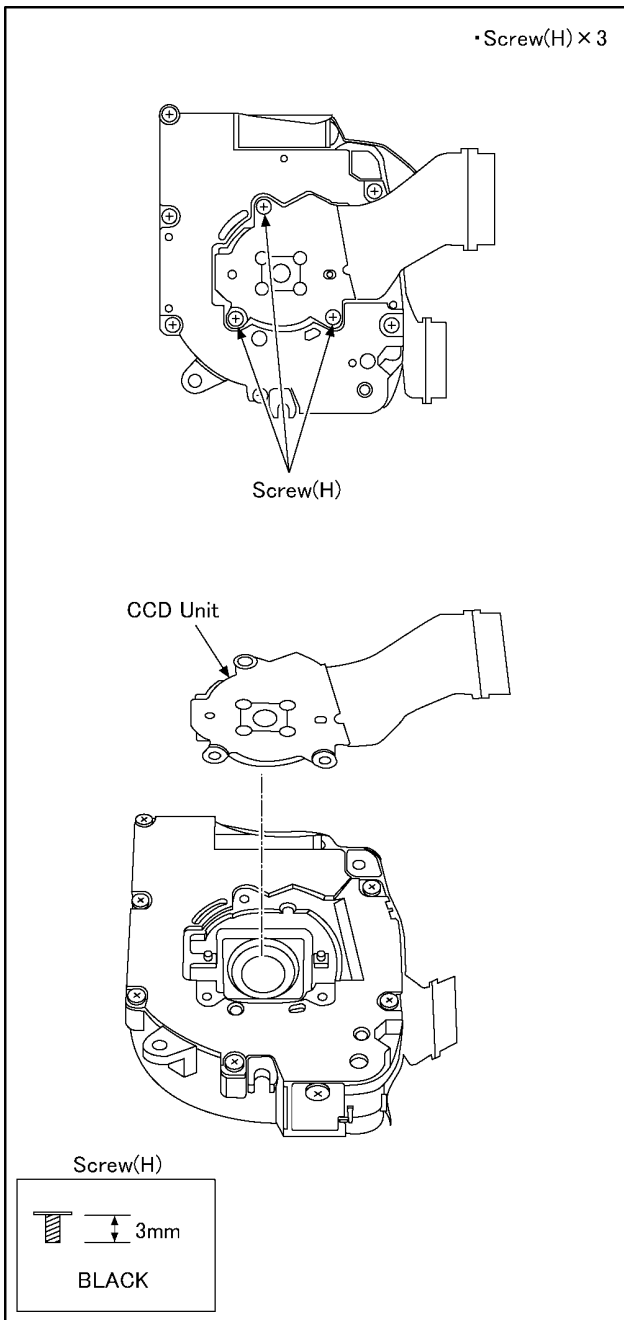

9 Measurements and Adjustments

9.1. Introduction

When servicing this unit, make sure to perform the adjustments necessary based on the part(s) replaced. Before disassembling the unit, it is recommended to back up the camera data stored in flash-rom as a data file.

IMPORTANT NOTICE (After replacing the MAIN P.C.B.)

After replacing the MAIN P.C.B., it is necessary to use the "DIAS" software to allow the release of adjustment flag(s). The Adjustment software "DIAS" is available at "TSN Website". To download, click on "Support Information from NWBG/VDBG-AVC".

*DIAS (DSC Integrated Assist Software)

9.2. Before Disassembling the unit

9.2.1. Initial Setting Release

The cameras specification are initially set in accordance with model suffix (such as EB, EG, GK, GC, and so on.). Unless the initial setting is not released, an automatic alignment software in the camera is not able to be executed when the alignment is carried out.

Note:

The initial setting should be again done after completing the alignment. Otherwise, the camera may not work properly. Therefore as a warning, the camera display a warning symbol "!" on the LCD monitor every time the camera is turned off. Refer to the procedure described in "3.5.2 INITIAL SETTINGS" for details.

[How to Release the camera initial setting]

Preparation:

- Attach the Battery or AC Adaptor with a DC coupler to the unit.
(Since this unit has built-in memory, it can be performed without inserting SD memory card.)
- 1. Turn the Power on.
- 2. Press the [MODE] button, and select the [NORMAL PICTURE] mode by Cursor buttons, then press the [MENU/SET] button.
- 3. Turn the Power off.
(If the unit is other than [NORMAL PICTURE] mode, it does not display the initial settings menu.)

Step 1. Temporary cancellation of "INITIAL SETTINGS":

While pressing "[W] side of Zoom button" and "[UP] of Cursor button" simultaneously, turn the Power on.

Step 2. Cancellation of "INITIAL SETTINGS":

Press the [PLAYBACK] button.

While pressing the "[UP] of Cursor button", press and hold the "[W] side of the Zoom button". Release only the "[UP] of Cursor button" once then press the "[UP] of Cursor button" again. Release the "[W]" and "[UP]" buttons, then turn the Power off. The LCD displays the "!" mark before the unit powers down.



9.2.2. Flash-Rom Data Backup

When trouble occurs, it is recommended to backup the Flash-rom data before disassembling the unit.

There are two kinds of Flash-rom data backup methods:

[ROM_BACKUP (Method of Non-PC backup)]

1. Insert the SD-card into the camera.
2. Set the camera to "Temporary cancellation of the initial settings".
3. Select the "SETUP" menu.

From the "SETUP" menu, select "ROM BACKUP".

NOTE:

This item is not listed on the customer's "SETUP" menu.

4. When this "ROM_BACKUP" item is selected, the following submenus are displayed.

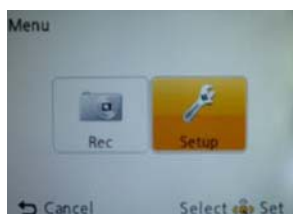

Fig.2-1

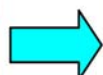

Fig.2-2

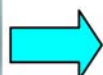

Fig.2-3

Item	Function	Details
DSC → SD	Save all the DSC's Flash-rom data to SD-CARD	*DSC's Flash-rom data is saved to the SD-CARD as a data file by the same format as the TATSUJIN software for the previous models. (DATA BACKUP) -File location: ROOT DIRECTORY in SD-CARD. -File Name: 1) User Setup Information data: <Model Number>U.txt [Example: DMC-FX66 : "FX66U.txt"] 2) Optical Adjustment data: <Model Number>F.txt [Example: DMC-FX66 : "FX66F.txt"] *If the concerned file already exists, "OVERWRITE?" message is displayed.
SDALL→ DSC (ID CHECK)	Write the all data to DSC's Flash-rom from SD-CARD	*The backup data being stored in the SD card is transferred to DSC unit. *ID CHECK: When the model ID is different, data is not transferred.
SDALL→ DSC (FORCE)	Write the all data to DSC's Flash-rom from SD-CARD	*FORCE: Even if the model ID is different, data is transferred. ※If the main PCB is replaced, select "SDALL → DSC (FORCE)".
SDUSER→DSC (FORCE)	Only "User setup information" is written from the saved file in the SD-CARD to DSC's Flash-rom.	*Only the user's "setup" setting condition is transferred to DSC unit. *FORCE: Even if the model ID is different, the data is transferred.
!→LUMIX	Shipping set without initializing "User setup information"	*Initial setting is executed without initializing the user's set up setting condition. ※ The initial setting must be perform while the Self-timer LED is blinking, ※ The picture data stored in the built-in memory of the DSC is not erased, with this operation.

[DSC Integrated Assist Software (Method of Using PC)]

Same as TATSUJIN software for previous models.

9.2.3. Light Box

If using VFK1164TDVLB Light Box, remove the lens connection ring by loosening three hexagonal screws.

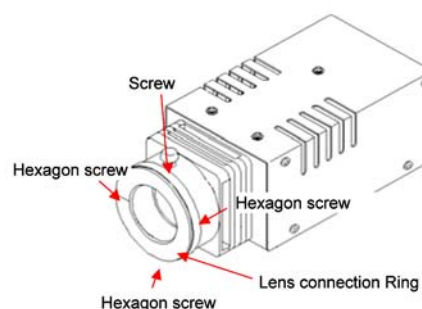

9.3. Details of Electrical Adjustment

9.3.1. How to execute the Electrical Adjustment

It is not necessary to connect the camera to a PC to perform adjustments.

“Flag reset operation” and “Initial setting operation” are required when carrying out the alignment, follow the procedure below.

9.3.1.1. Startup Electrical Adjustment mode

1. Release the initial settings.
2. Insert a recordable SD card.
(Without a SD card, the automatic adjustment can not executed.)
3. Procedure to set the camera into adjustment mode:
 - a. Turn the Power on.
 - b. Press the [MODE] button, and select the [NORMAL PICTURE] mode by Cursor buttons, then press the [MENU/SET] button.
 - c. Turn the Power off.
 - d. Turn the Power on pressing “[W] side of Zoom button” and [MODE] button simultaneously.
LCD monitor displays “SERVICE MODE”.(Refer to Fig. 3-1)

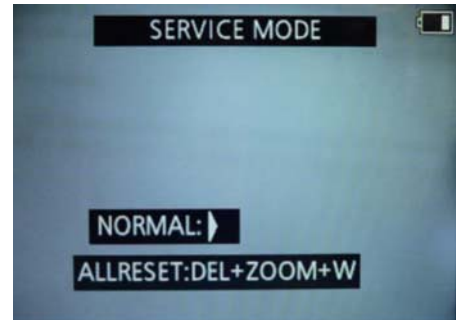

Fig.3-1

9.3.1.2. Status Adjustment Flag Setting

Reset (Not yet adjusted) the status flag condition.

1. After pressing the “[W] side of Zoom button”, the LCD monitor displays the Flag status screen (Refer to Fig.3-2)
2. Select item by pressing the Cursor buttons. (Gray cursor is moved accordingly.)
3. Press the [Delete/Return] button.

NOTE:

The selected item's flag has been changed from “F (green)” to “0 (yellow)”.

*Flag conditions:

F (green)

means that the alignment has been completed and the status flag condition is set. In this case, the flag condition should be reset, if you try to carry out the automatic alignment.

0 (yellow)

means that the alignment has been not “completed” and the status flag condition is “reset”. In this case, automatic alignment is available.

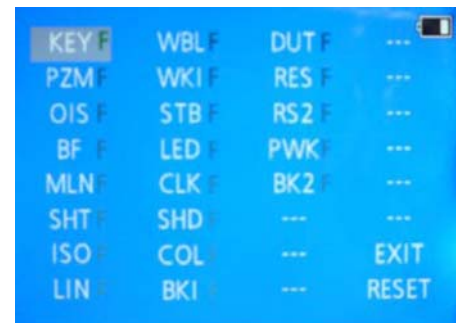

Fig.3-2

- In case of setting the status flag into set condition again without completion of the alignment, the status flag should be SET by using PC, or UNDO by using ROM BACKUP function.

9.3.1.3. Execute Adjustment (In case of “OIS Adjustment”)

1. Perform step “9.3.1.1.” to “9.3.1.2.”, to reset the OIS flag status “F” (Set) to “0” (Reset)
2. Press “[W] side of the zoom button” after Flag reset. OIS Adjustment screen is displayed on the LCD panel. (Refer to Fig.3-3)
3. Press the [Shutter] button. The adjustment will start automatically.

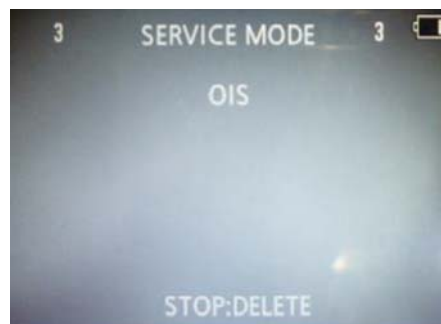

Fig.3-3

4. When the adjustment is completed successfully, adjustment report menu appears with Green OK on the LCD monitor. (Refer to Fig.3-4)



Fig.3-4

9.3.1.4. Attention point during Adjustment

1. Step “9.3.1.3.” procedure shows OIS adjustment as an example. To perform the adjustment, refer to the “9.3.2. Adjustment Specifications” table which shows key point for each adjustment.
2. Do not move the light box, the camera or the chart while adjusting. If one of these is moved accidentally, start the adjustment again.
3. Do not press any buttons/keys until the default menu (Fig.3-5) is displayed on the LCD monitor. Otherwise, adjustment data may not be stored properly.
4. If the adjustment is interrupted accidentally, the alignment data may not be properly saved in the Flash-rom.

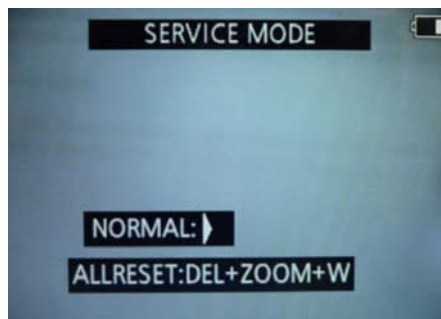

Fig.3-5

9.3.1.5. Finalizing the Adjustment

1. Several adjustment flags can be reset (“F” into “0”) at the same time. In this case, when the adjustment has been completed, the screen will change showing the adjustment for the next item until all reset items are completed. Also, when the shutter button is pressed, the screen jump to the next adjustment item.
2. To cancel the adjustment mode while in the process of performing the adjustment, follow this procedures.
(1) Press “[RIGHT] of cursor button”.

NOTE:

- If adjustment is cancelled with above procedure, adjustment is not completed. Make sure to adjust it later.
- Adjustment software “DIAS” is able to control the status of the adjustment flags.

9.3.2. Adjustment Specifications

The following matrix table shows the relation between the replaced part and the Necessary Adjustment.

When a part is replaced, make sure to perform the necessary adjustment(s) in the order indicated.

The table below shows all the information necessary to perform each adjustment.

Adjustment order	Adjustment Item	FLAG	Purpose	Replacing Parts			JIG/TOOLS	SET UP	How to Operate
				MAIN P.C.B.	Lens part (Except CCD U)	CCD UNIT			
1	Venus Zoom	PZM	Venus Zoom Inspection	○	—	—	NONE	Connect the USB cable to the unit. (Do not connect any equipment to the other side of USB cable. It has to be opened.)	1)Press Shutter Button 2)After displaying "PZM", press Shutter Button again. 3)After completed, the"OK" message appears.
2	OIS sensor	OIS	OIS sensor output level adjustment	○	○	—	NONE	NONE	1)Press Shutter Button (Do not apply any shock and vibration for the camera while adjusting) 2)After completed, the"OK" message appears.
3	Backfocus / GYRO	BF	To have the focus tracking curve be appropriate shape and GYRO sensor adjustment	○	○	○ ※1	•COLLIMATOR (VFK1164TCM02 or VFK1164TCM03 or RFKZ0422)	1)Set the camera in front of collimator so that the distance between collimator and camera becomes about 2 cm as shown in Fig.A. 【NOTE】 Please note that "NG" might happen while auto adjusting. - Do not put the black colored stuff at the back side of collimator near hunching chart to get some certain brightness. - Make sure the hunting chart has no dust and dirty condition. - Not connect the USB cable at this stage.	1)Press Shutter Button (Do not apply any shock and vibration for the camera while adjusting) 2)After completed, the"OK" message appears.
4	Monitor Linearity	MLN	Monitor Linearity adjustment	○	○	○	•LIGHT BOX RFKZ0523 (VFK1164TDVLB) •TR CHART (RFKZ0443)	1)Set the camera in front of LIGHTBOX so that the distance between collimator and camera becomes about 3 cm as shown in Fig.B.	1)Press Shutter Button 2)After completed, the "OK" message appears.
5	Shutter	SHT	Shutter speed adjustment	○	○	○		1) Insert the TR chart into the slot of LIGHTBOX. 2) Set the camera in front of LIGHTBOX so that the distance between LIGHTBOX and camera becomes about 13 cm as shown in FigB. 3) Set the camera angle so that the color chart is displayed on the LCD monitor fully. 【NOTE】 - Since the lens position is automatically set into certain position after executing auto adjustment, confirm the angle after stopping the lens zoom position. - It is no problem even though the chart on to the LCD monitor slightly cut at the corner. - It is no problem even though the focusing slightly becomes out of focusing condition. - Not connect the USB cable at this stage.	1)Press Shutter Button 2)After completed, the "OK" message appears.
6	ISO	ISO	ISO sensitivity adjustment	○	○	○		1)Press Shutter Button 2)After completed, the "OK" message appears.	
7	High brightness coloration	LIN	High brightness coloration adjustment	○	○	○		1)Press Shutter Button 2)After completed, the "OK" message appears.	
8	White Balance	WBL	White balance adjustment under various color temperature	○	○	○		1)Press Shutter Button 2)After completed, the "OK" message appears.	
9	CCD Missing Pixels (White)	WKI	Compensation of CCD Missing Pixels (White)	○	—	○ ※1	NONE	NONE	1)Press Shutter Button 2)After completed, the"OK" message appears.
10	Color reproduction inspection and Microphone check	COL	Color reproduction inspection and Microphone check	○	○	○	NONE	NONE	1)Press Shutter Button 2)After completed, the "OK" message appears.
		BKI	Do not use "BK1" adjustment flag for this unit. Use "BK2" adjustment flag, instead. (In case of mostDSC models, the adjustment flag for CCD Missing Pixels is "BK1". But, in this model, "BK2" the adjustment flag for CCD Missing Pixels.)						

Adjustment order	Adjustment Item	FLAG	Purpose	Replacing Parts			JIG/TOOLS	SET UP	How to Operate
				MAIN P.C.B.	Lens part (Except CCD U)	CCD UNIT			
11	CCD Missing Pixels (Black)	BK2	Compensation of CCD Missing Pixels (Black)	○	—	※1 ○	-LIGHT BOX RFKZ0523 (VFK1164TDVLB) -ND FILTER (VFK1164ND15)	1) Prepare the LIGHTBOX (RFKZ0523). (The LIGHTBOX "VFK1164TDVLB" can be used if the front hood of VFK1164TDVLB is removed.) 2) Set the ND Filter (VFK1164ND15) to the LIGHTBOX. 3) Set the LIGHTBOX and Camera unit so that distance becomes about 3 cm. NOTE: Do not use "BK1" adjustment flag for this unit. Use "BK2" adjustment flag, instead.	1) Press Shutter Button. (The lens starts zooming and stops automatically, then green ● mark is displayed on LCD). 2) Aim the LIGHTBOX so that the entire LCD screen becomes fully "white". (No dark area). 3) Press Shutter Button. (The <BK1 adjustment 1> is executed, and then green ● mark is displayed on LCD). 4) Press Shutter Button. (The lens starts zooming and stops automatically, then green ● mark is displayed on LCD). 5) Press Shutter Button. (The <BK1 adjustment 2> is executed, and then green ● mark is displayed on LCD). 6) Press Shutter Button. (The lens starts zooming and stops automatically, then green ● mark is displayed on LCD). 7) Press Shutter Button. (The <BK1 adjustment 3> is executed, and then green ● mark is displayed on LCD). 8) Press Shutter Button. ("OK" mark is displayed on LCD when the adjustment has been completed successfully.)

※1: Execute the adjustment when remove the CCD unit and replace the CCD unit.

※2: The pixel that always lights while shaded is called a white wound.

※3: The pixel that does not light while complete exposed is called a black wound.

*This unit does not have the LCD adjustment of the camera (LCD flicker adjustment etc.).

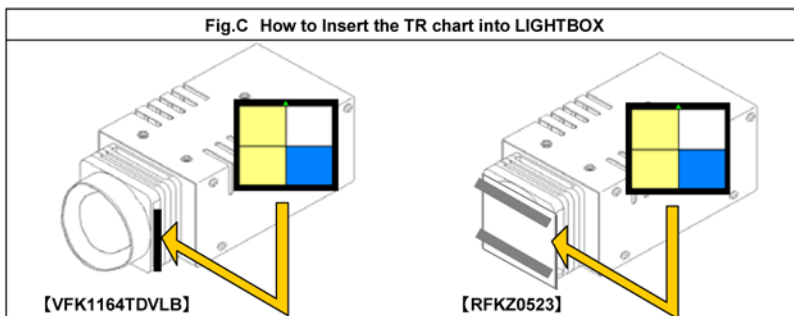
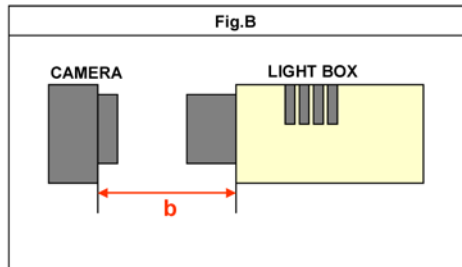
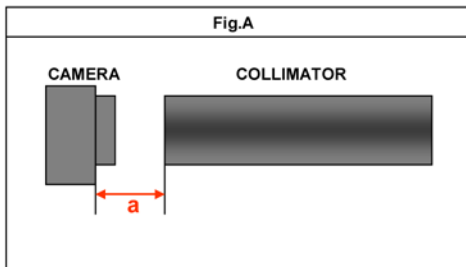

IMPORTANT NOTICE (After replacing the MAIN P.C.B.)
 After replacing the MAIN P.C.B., make sure to perform the "INITIAL SETTINGS" first, then release the "INITIAL SETTINGS" in order to proceed the electrical adjustment.

NOTE:

- 1). If electrical adjustment or data re-writing is executed before "INITIAL SETTINGS", suffix code list is never displayed, and it cannot be chosen suitable suffix code.
- 2). Never remove the battery during initial setting in process.

9.4. After Adjustment

9.4.1. Initial Setting

Since the initial setting has been released to execute the built-in adjustment software, it should be set up again before shipping the camera to the customer.

Refer to the procedure described in “3.5.2. INITIAL SETTINGS” for details.

[IMPORTANT]

1. The initial setting should be done again after completing the alignment. Otherwise, the camera will not work properly.
Therefore as a warning, the camera display a warning symbol “ ! ” on the LCD monitor every time the camera is turned off.
2. Confirm that status of all adjustment flag show “F”. Even if one of the adjustment flag shows “0”, initial setting programmed is never executed.

10 Maintenance

10.1. Cleaning Lens and LCD Panel

Do not touch the surface of lens and LCD Panel with your hand.

When cleaning the lens, use air-Blower to blow off the dust.

When cleaning the LCD Panel, dampen the lens cleaning paper with lens cleaner, and the gently wipe the its surface.

Note:

The Lens Cleaning KIT ; VFK1900BK (Only supplied as 10 set/Box) is available as Service Aid.

Service Manual

Diagrams and Replacement Parts List

Digital Camera

Model No.

DMC-S1P	DMC-S1EP	DMC-S3P	DMC-S3EP
DMC-S1PC	DMC-S1GA	DMC-S3PC	DMC-S3GA
DMC-S1PR	DMC-S1GC	DMC-S3PR	DMC-S3GC
DMC-S1PU	DMC-S1GD	DMC-S3PU	DMC-S3GD
DMC-S1EB	DMC-S1GF	DMC-S3EB	DMC-S3GF
DMC-S1EE	DMC-S1GK	DMC-S3EE	DMC-S3GK
DMC-S1EF	DMC-S1GN	DMC-S3EF	DMC-S3GN
DMC-S1EG	DMC-S1GT	DMC-S3EG	DMC-S3GT

Colour

[DMC-S1]	[DMC-S3]
(A).....Blue Type (except PR/PU/EB/EF/GD/GK/GT)	(A).....Blue Type (only P/PC/EB/EE/EG/EP/GK/GN)
(K).....Black Type	(K).....Black Type
(N).....Gold Type (only P)	(R).....Red Type (except GD)
(P).....Pink Type (only GA/GC/GD/GF/GT)	(V).....Violet Type (except PR/PU/EE/EG/GT)
(PA).....Pink Type (only P/PR/PU/EB/EE/EG/EP/GN)	(W).....White Type
(S).....Silver Type (except EB/EF/GD)	
(W).....White Type (only GA/GC/GD/GF/GK/GN/GT)	

Table of contents

S1. About Indication of The Schematic Diagram.....	S-1	S6. Replacement Parts List.....	S-15
S1.1. Important Safety Notice.....	S-1		
S2. Voltage Chart.....	S-2	S7. Exploded View.....	S-20
S2.1. Flash P.C.B.	S-2	S7.1. Frame and Casing Section.....	S-20
S3. Block Diagram.....	S-3	S7.2. Packing Parts and Accessories Section (1).....	S-21
S3.1. Overall Block Diagram.....	S-3	S7.3. Packing Parts and Accessories Section (2).....	S-22
S3.2. Flash/Top Block Diagram.....	S-4		
S4. Schematic Diagram.....	S-5		
S4.1. Interconnection Diagram.....	S-5		
S4.2. Flash Schematic Diagram.....	S-6		
S4.3. Top Schematic Diagram.....	S-7		
S4.4. S1 CCD Flex Schematic Diagram.....	S-8		
S4.5. S3 CCD Flex Schematic Diagram.....	S-9		
S5. Print Circuit Board.....	S-10		
S5.1. Flash P.C.B.	S-10		
S5.2. Top P.C.B.	S-11		
S5.3. S1 CCD Flex P.C.B.	S-12		
S5.4. S3 CCD Flex P.C.B.	S-13		

S1. About Indication of The Schematic Diagram

S1.1. Important Safety Notice

COMPONENTS IDENTIFIED WITH THE MARK \triangle HAVE THE SPECIAL CHARACTERISTICS FOR SAFETY. WHEN REPLACING ANY OF THESE COMPONENTS USE ONLY THE SAME TYPE.

1. Although reference number of the parts is indicated on the P.C.B. drawing and/or schematic diagrams, it is NOT mounted on the P.C.B. when it is displayed with "\$" mark.
2. It is only the "Test Round" and no terminal (Pin) is available on the P.C.B. when the TP (Test Point) indicated as "●" mark.
3. The voltage being indicated on the schematic diagram is measured in "Standard-Playback" mode when there is no specify mode is mentioned.
4. Although the voltage and waveform available on here is measured with standard frame, it may be differ from actual measurement due to modification of circuit and so on.
5. The voltage being indicated here may be include observational-error (deviation) due to internal-resistance and/or reactance of equipment. Therefore, handle the value indicated on here as reference.
6. Use the parts number indicated on the Replacement Parts List .
7. Indication on Schematic diagrams:

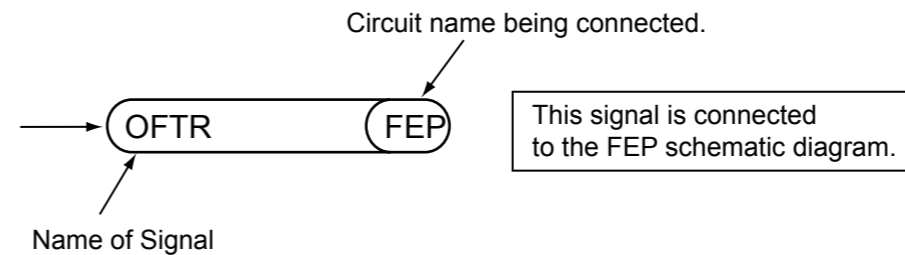

S2. Voltage Chart

Note) Indicated voltage values are the standard values for the unit measured by the DC electronic circuit tester (high-impedance) with the chassis taken as standard.
Therefore, there may exist some errors in the voltage values, depending on the internal impedance of the DC circuit tester.

S2.1. Flash P.C.B.

REF No.	PIN No.	POWER ON
IC8100	1	0
IC8100	2	0
IC8100	3	0
IC8100	4	0
IC8100	5	3.4
IC8100	6	0
IC8100	7	0
IC8100	8	0
IC8100	9	3.1
IC8100	10	3.6

S3. Block Diagram

S3.1. Overall Block Diagram

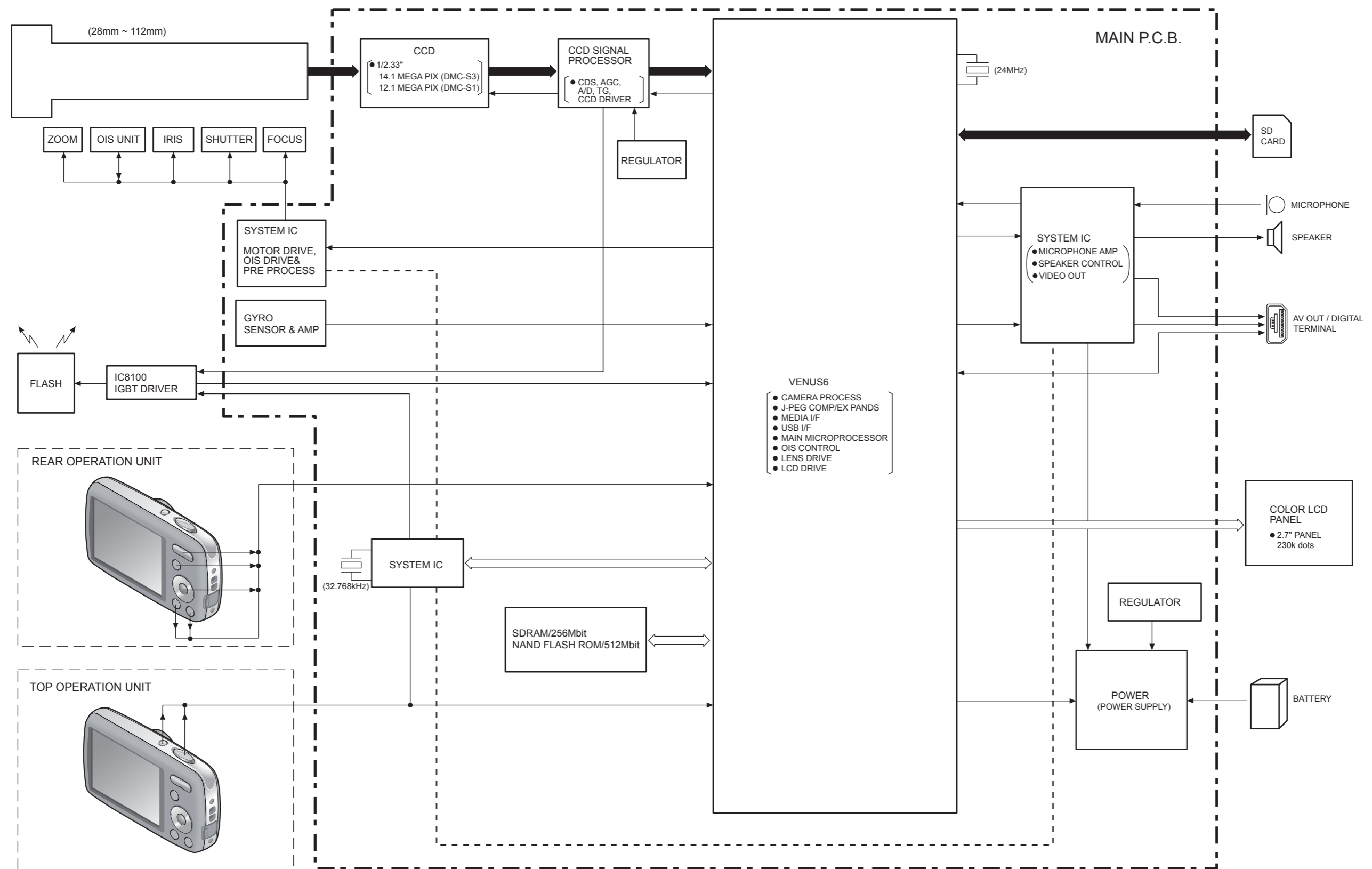

S3.2. Flash/Top Block Diagram

◆ FLASH BLOCK DIAGRAM

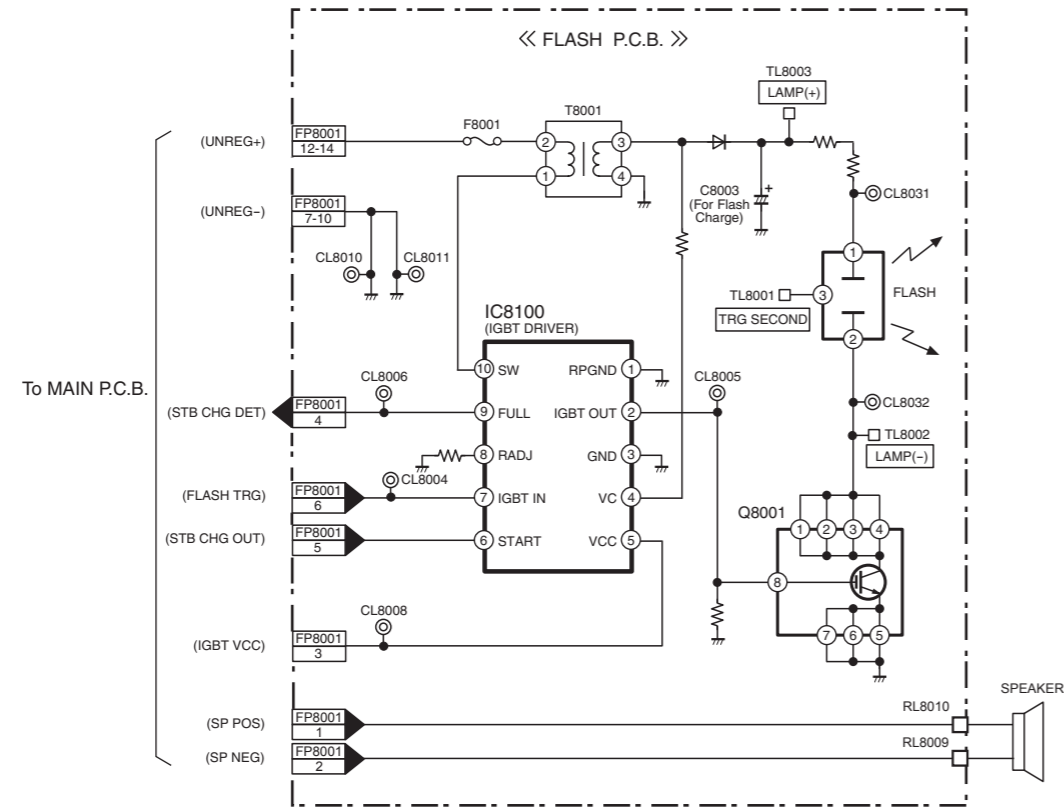

◆ TOP BLOCK DIAGRAM

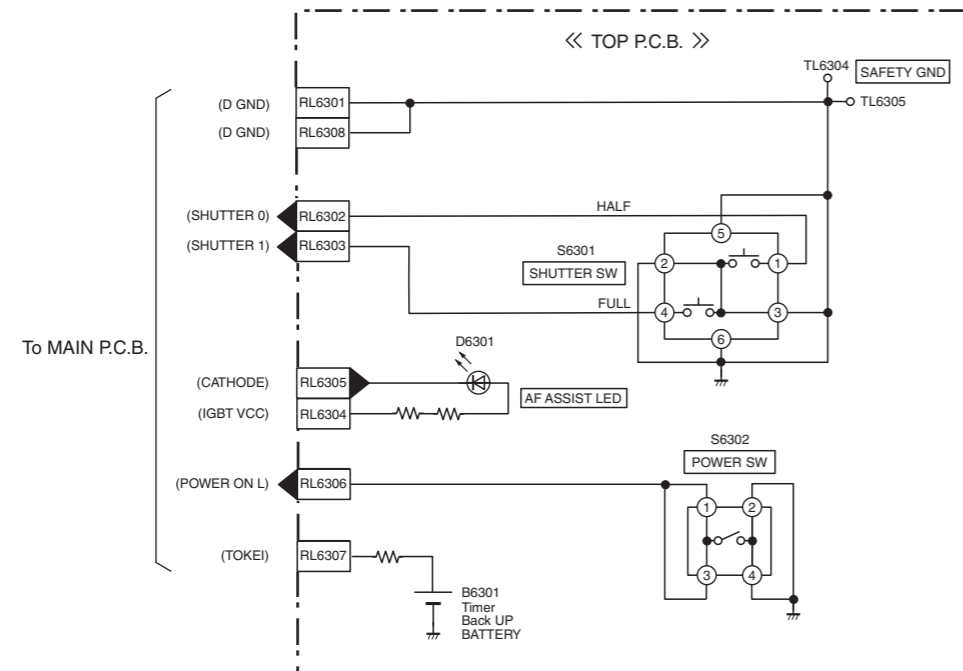

S4. Schematic Diagram

S4.1. Interconnection Diagram

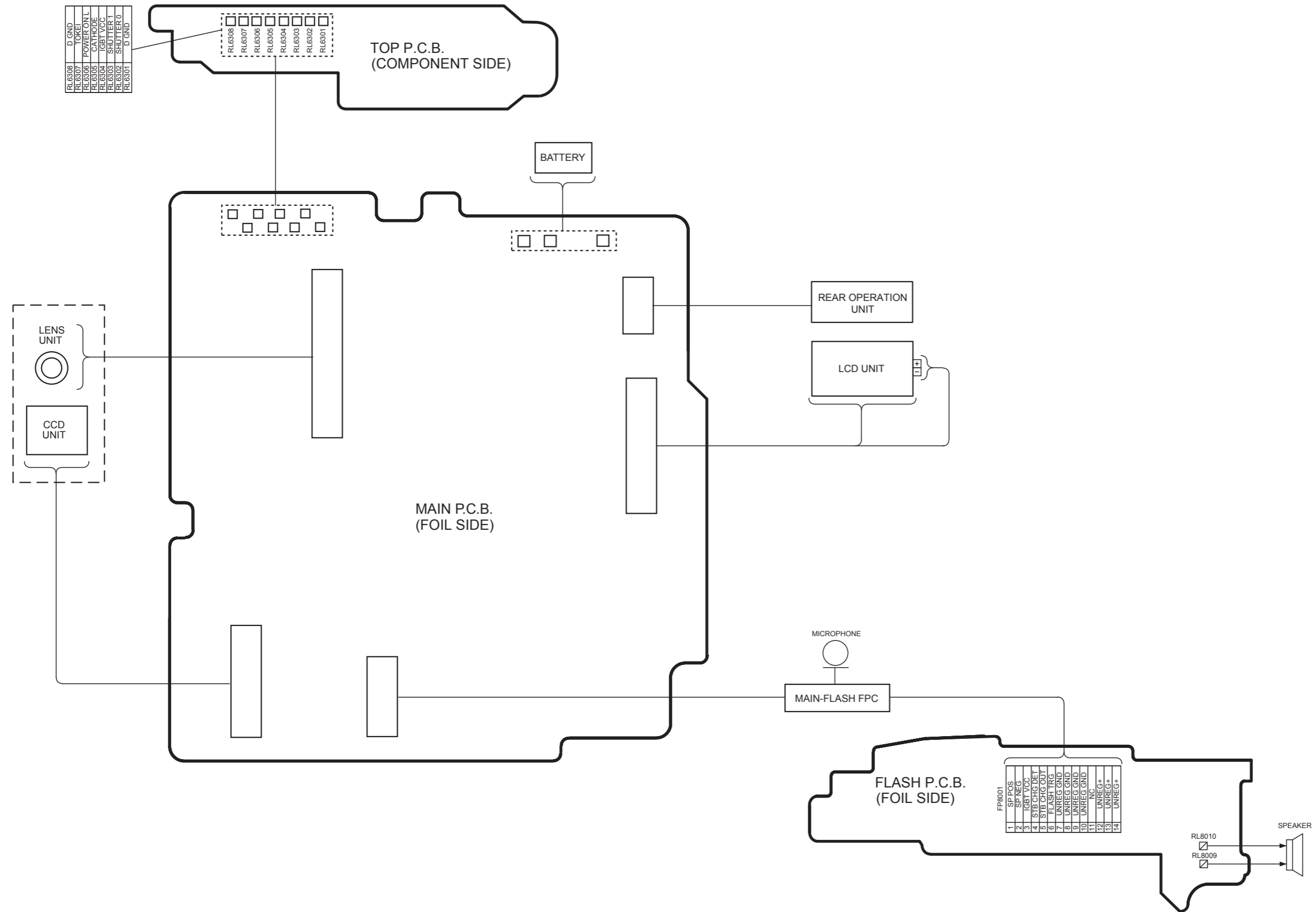

S4.2. Flash Schematic Diagram

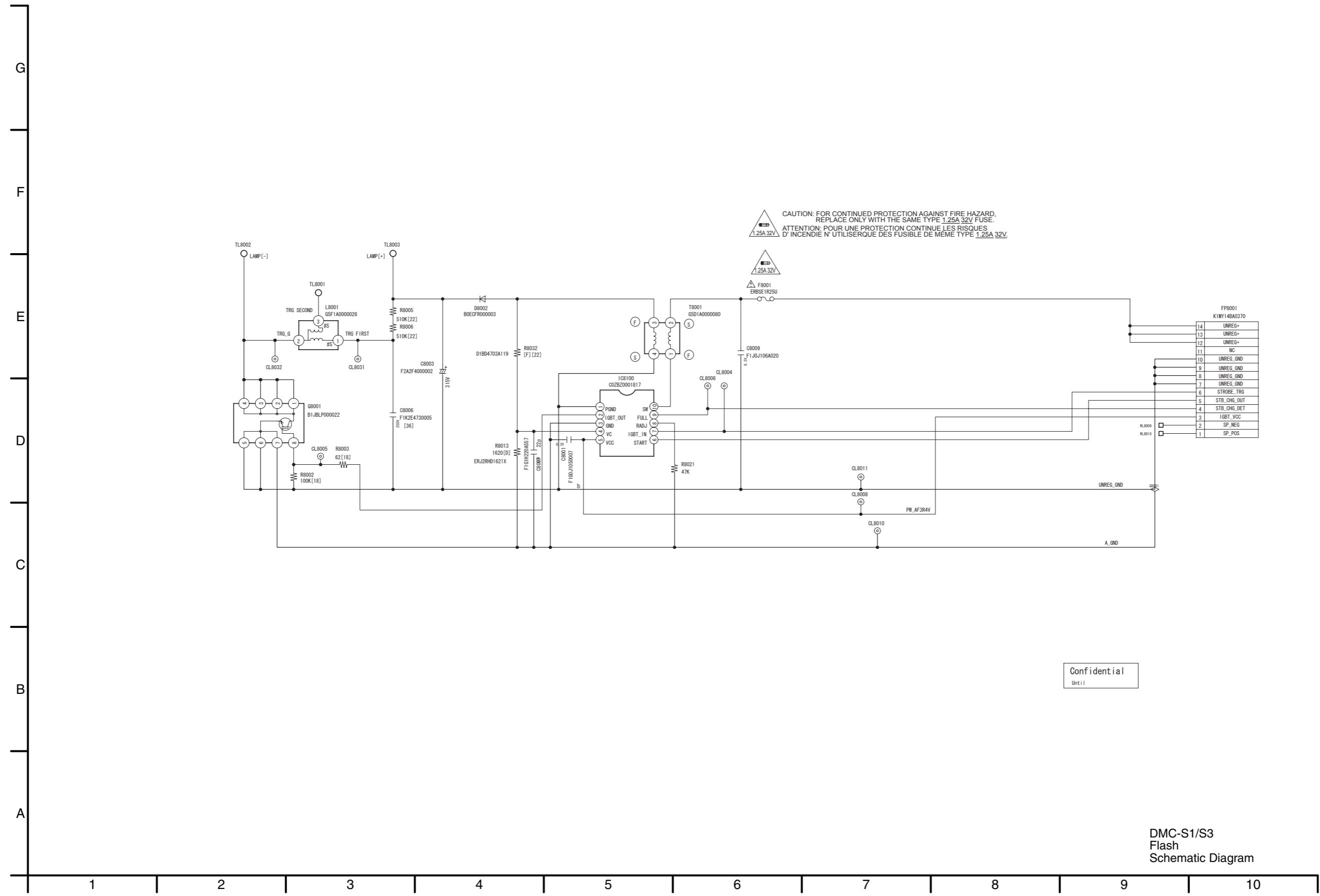

S4.3. Top Schematic Diagram

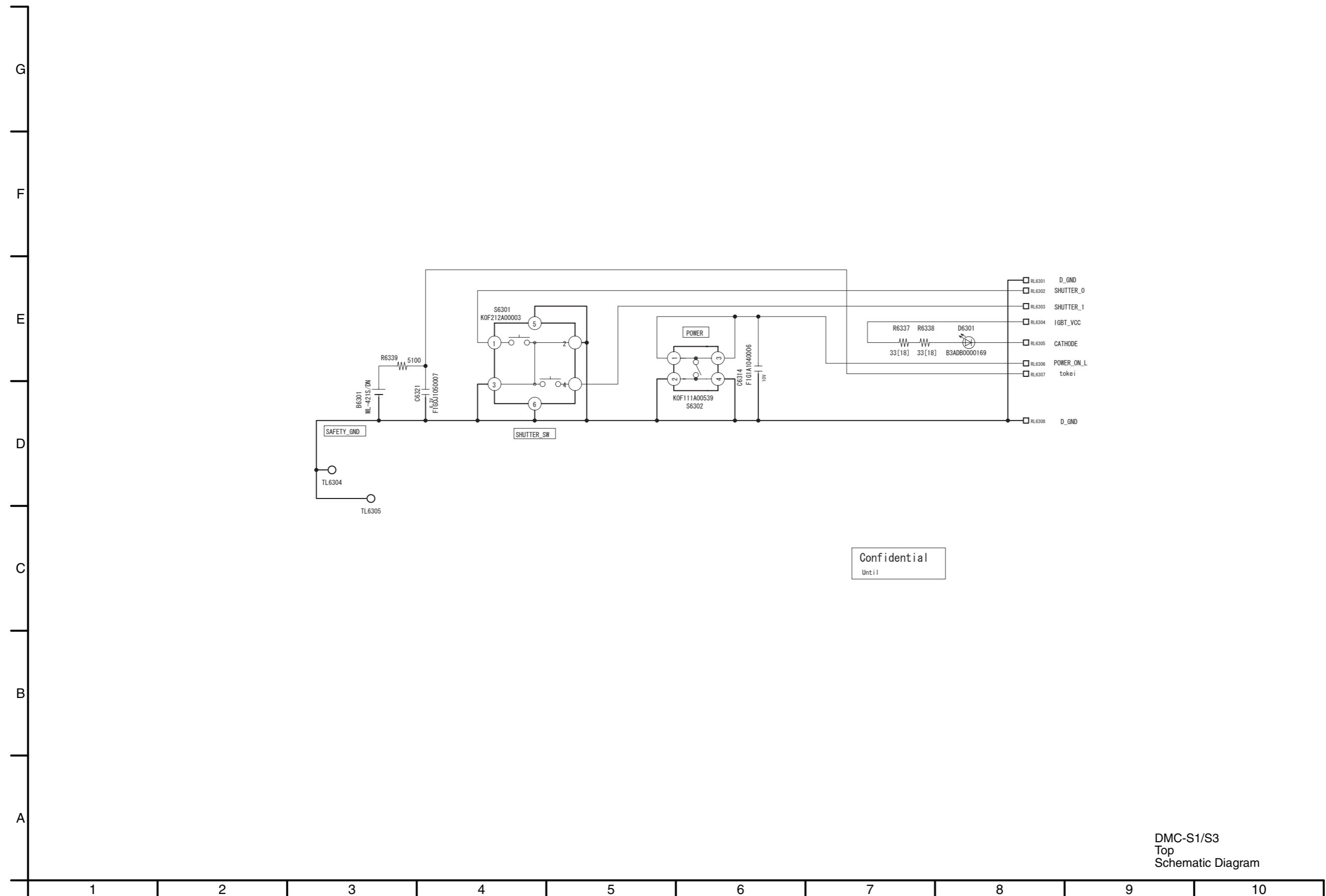

Confidential
Until

S4.4. S1 CCD Flex Schematic Diagram

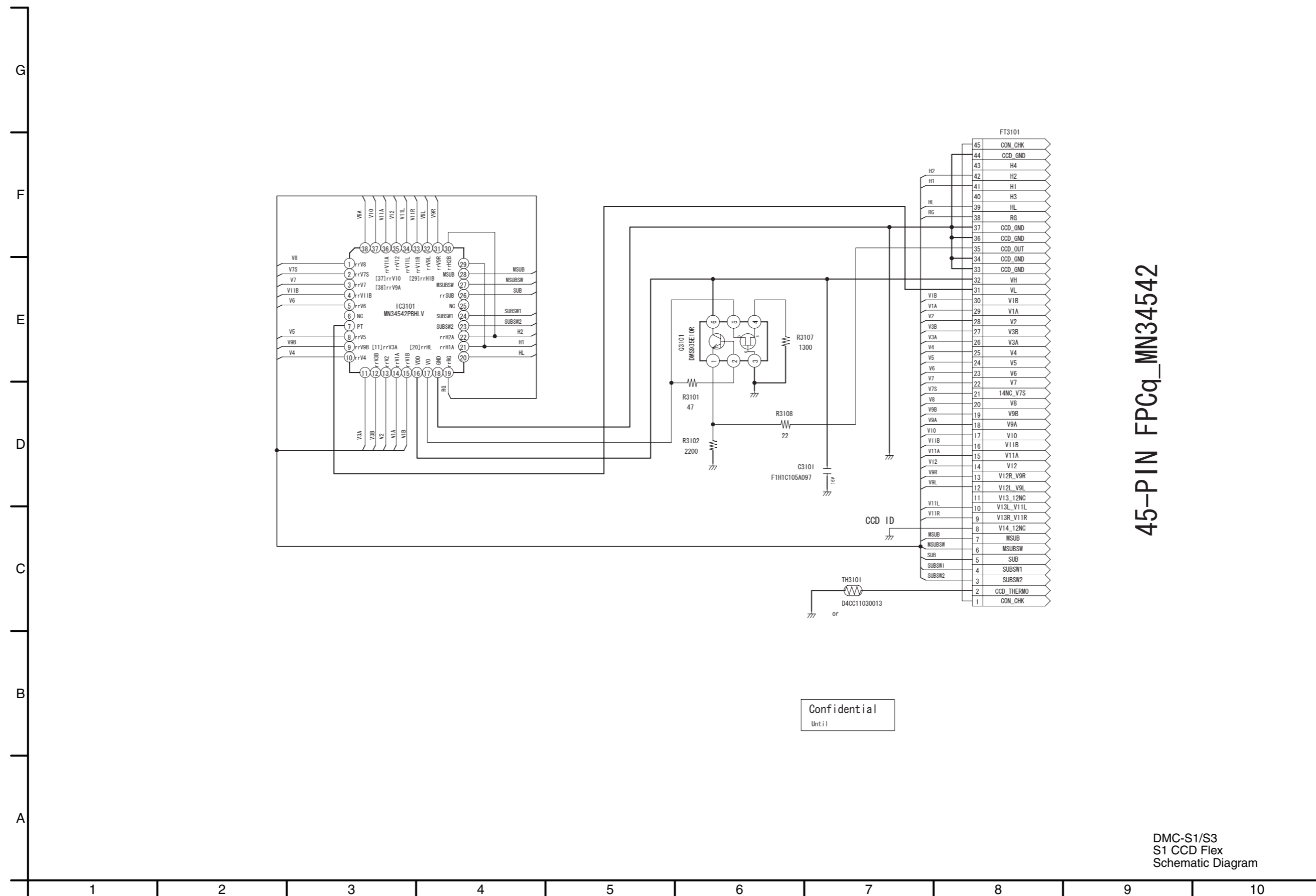

45-PIN FPCq_MN34542

Confidential
Until

S4.5. S3 CCD Flex Schematic Diagram

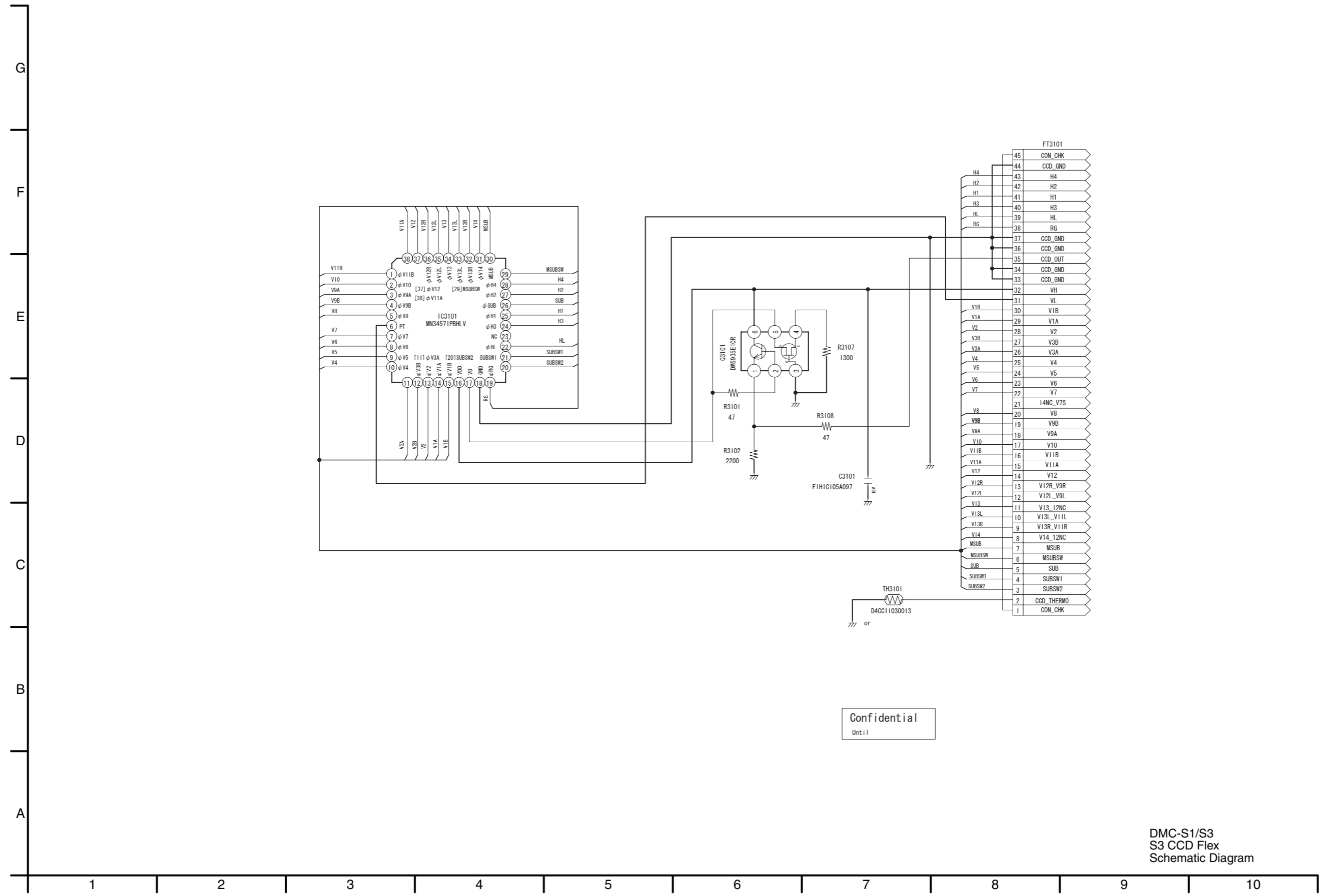

Confidential
Until

S5. Print Circuit Board

S5.1. Flash P.C.B.

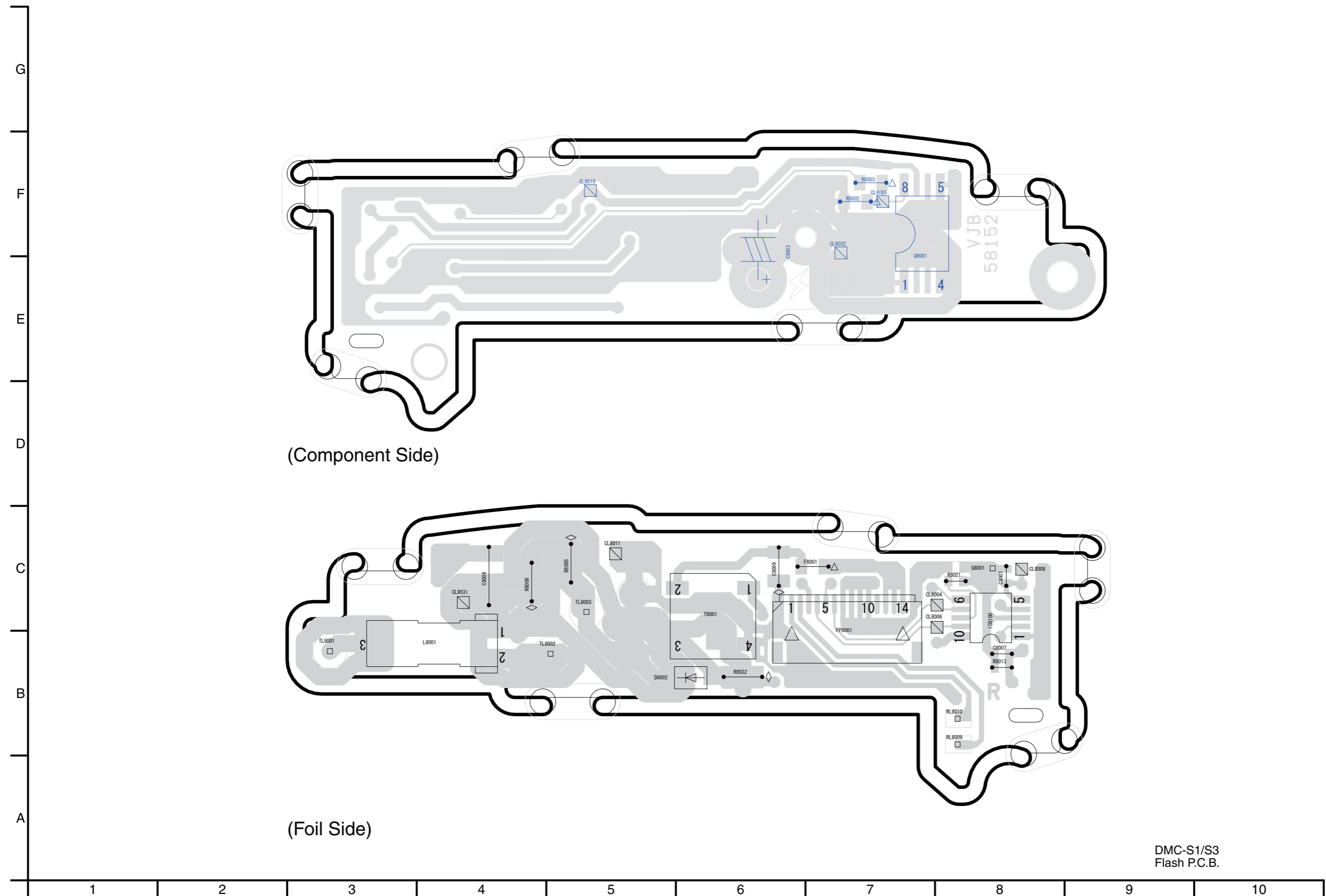

DMC-S1/S3
Flash P.C.B.

S5.2. Top P.C.B.

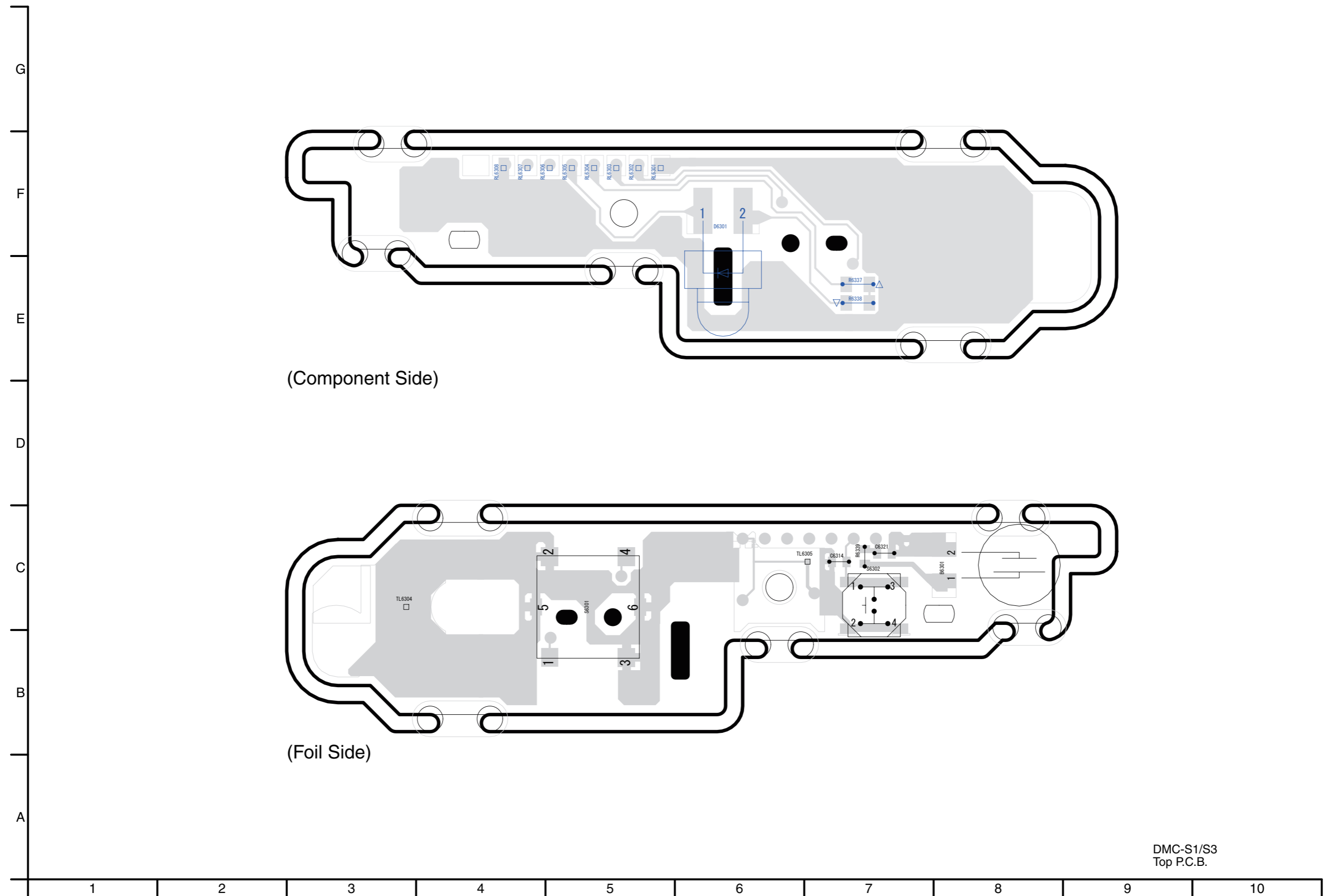

(Component Side)

(Foil Side)

DMC-S1/S3
Top P.C.B.

S5.3. S1 CCD Flex P.C.B.

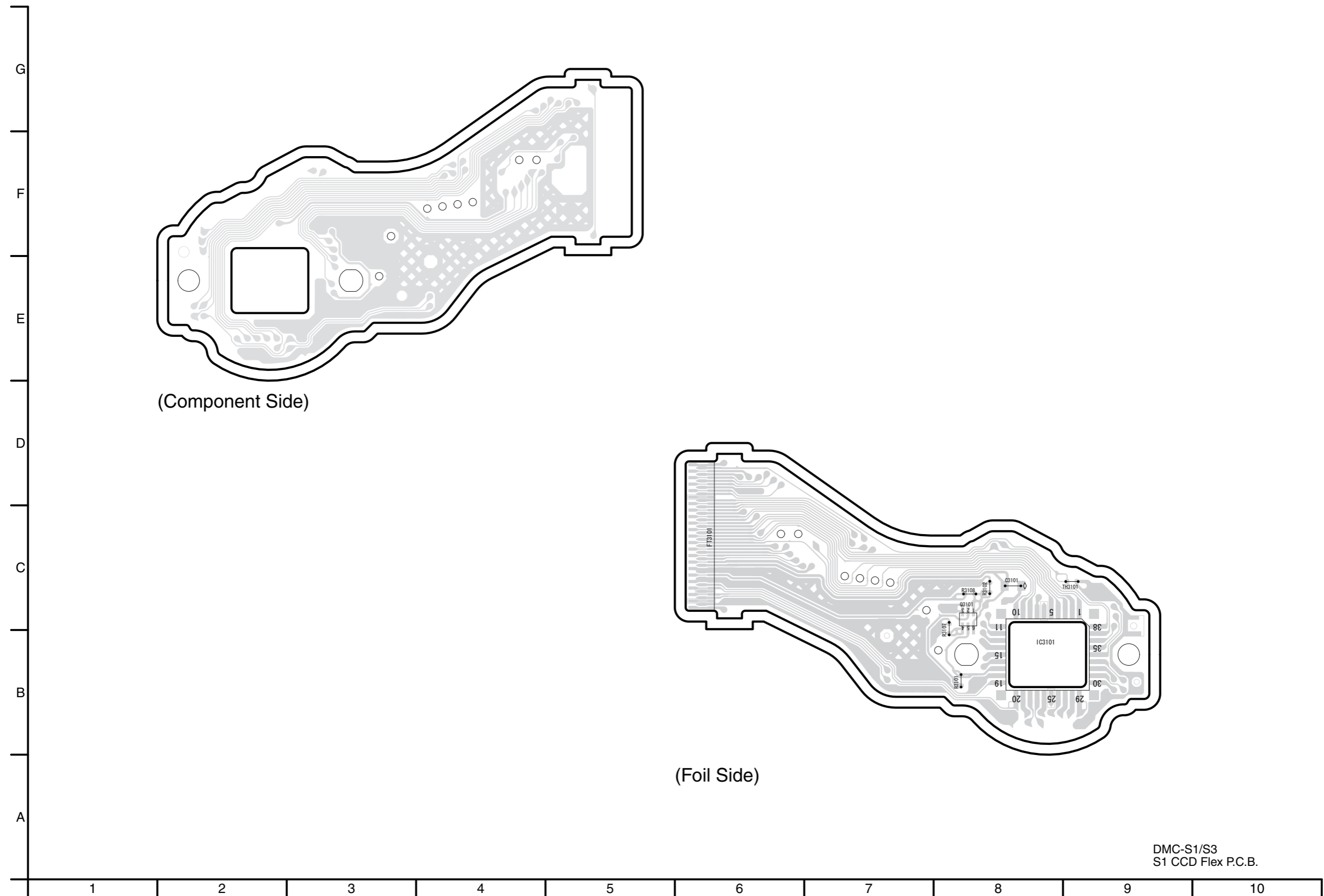

DMC-S1/S3
S1 CCD Flex P.C.B.

S5.4. S3 CCD Flex P.C.B.

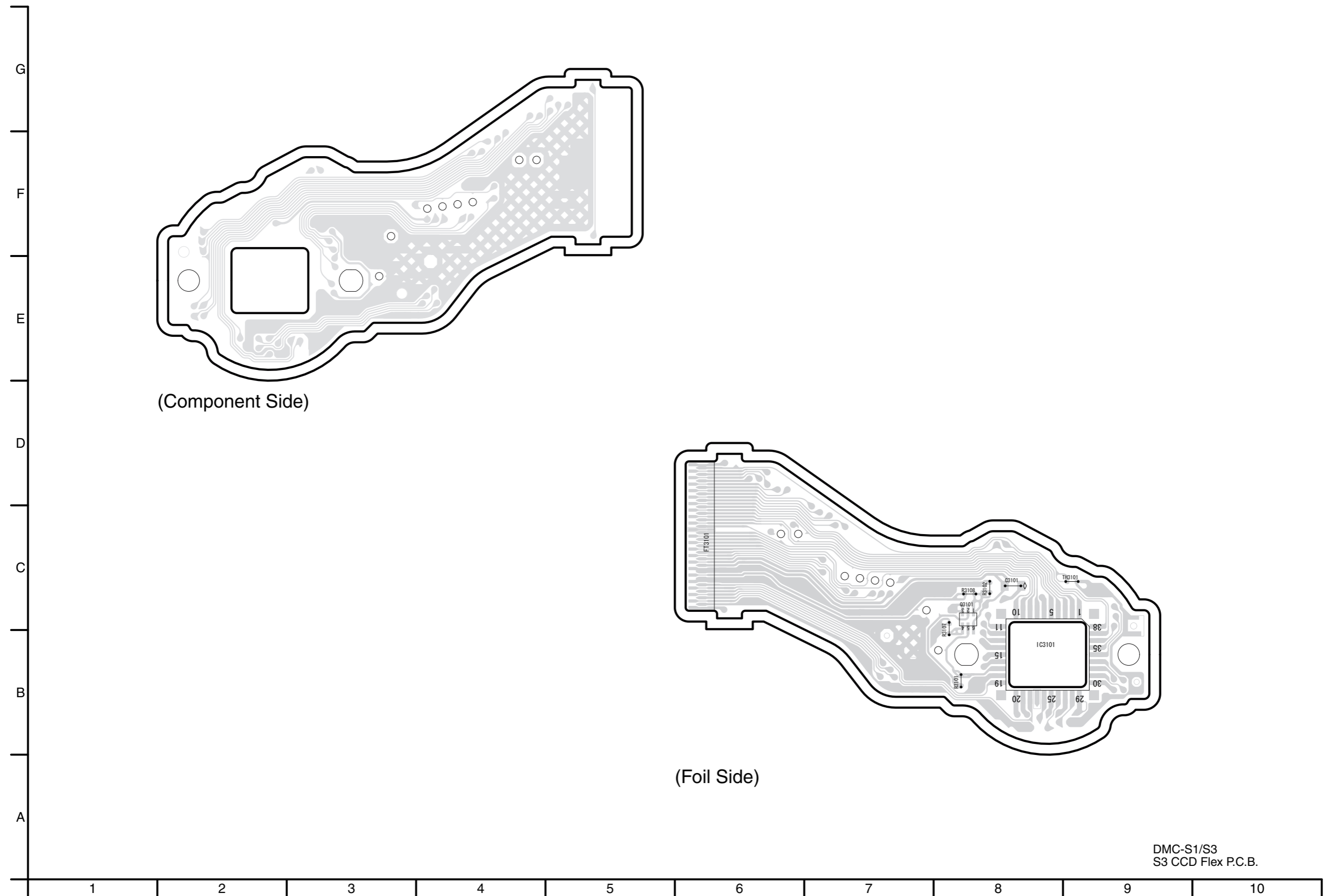

DMC-S1/S3
S3 CCD Flex P.C.B.

S6. Replacement Parts List

- Note: 1.* Be sure to make your orders of replacement parts according to this list.
2. IMPORTANT SAFETY NOTICE
Components identified with the mark \triangle have the special characteristics for safety.
When replacing any of these components, use only the same type.
3. Unless otherwise specified,
All resistors are in OHMS, K=1,000 OHMS. All capacitors are in MICRO-FARADS (uf), P=uuF.
4. The marking (RTL) indicates the retention time is limited for this item. After the discontinuation of this assembly in production, it will no longer be available.
5. Supply of CD-ROM, in accordance with license protection, is allowable as replacement parts only for customers who accidentally damaged or lost their own.

E.S.D. standards for Electrostatically Sensitive Devices, refer to PREVENTION OF ELECTROSTATIC DISCHARGE (ESD) TO ELECTROSTATICALLY SENSITIVE (ES) DEVICES section.

<DEFINITION OF PARTS SUPPLIER>

1. Parts marked with [ENERGY] in the remarks column are supplied from Panasonic Corporation Energy Company.
2. Parts marked with [SPC] in the remarks column are supplied from AVC-CSC-SPC.
Others are supplied from PAVCSG (Panasonic AVC Networks Singapore Pte. Ltd.).

DMC-S1EB-K

Ref.No.	Part No.	Part Name & Description	Pcs	Remarks
##	VEP56128A	MAIN P.C.B.	1	(DMC-S1) E.S.D.
##	VEP56128B	MAIN P.C.B.	1	(DMC-S3) E.S.D.
##	VEP58152A	FLASH P.C.B.	1	(RTL) E.S.D.
##	VEP58153A	TOP P.C.B.	1	(RTL)
##	VEK0R19	CCD UNIT	1	(DMC-S1) E.S.D.
##	VEK0R37	CCD UNIT	1	(DMC-S3) E.S.D.
##	VEP58152A	FLASH P.C.B.	1	(RTL) E.S.D.
C8001	F1G0J1050007	C.CAPACITOR CH 6.3V 1U	1	
C8006	F1K2E4730005	C.CAPACITOR 250V 0.047U	1	
C8007	F1G1H220A557	C.CAPACITOR CH 50V 22P	1	
C8009	F1J0J106A020	C.CAPACITOR CH 6.3V 10U	1	
D8002	B0ECFR000003	DIODE	1	E.S.D.
△ F8001	ERBSE1R25U	FUSE 32V 1.25A	1	
FP8001	K1MY14BA0370	CONNECTOR 14P	1	
IC8100	C0ZBZ0001817	IC	1	E.S.D.
L8001	G5F1A0000026	CHIP INDUCTOR	1	
Q8001	B1JBLP000022	TRANSISTOR	1	E.S.D.
R8002	ERJ3GEYJ104V	M.RESISTOR CH 1/10W 100K	1	
R8003	ERJ3GEYJ620V	M.RESISTOR CH 1/10W 62	1	
R8005	ERJ6GEYJ514V	M.RESISTOR CH 1/8W 510K	1	
R8006	ERJ6GEYJ514V	M.RESISTOR CH 1/8W 510K	1	
R8013	ERJ2RHD1621X	M.RESISTOR CH 1/16W 1620	1	
R8021	ERJ2GEJ473X	M.RESISTOR CH 1/16W 47K	1	
R8032	D1BD4703A119	RESISTOR	1	
T8001	G5D1A0000080	TRANSFORMER	1	
##	VEP58153A	TOP P.C.B.	1	(RTL)
C6314	F1G1A1040006	C.CAPACITOR CH 10V 0.1U	1	
C6321	F1G0J1050007	C.CAPACITOR CH 6.3V 1U	1	
R6337	ERJ3GEYJ330V	M.RESISTOR CH 1/10W 33	1	
R6338	ERJ3GEYJ330V	M.RESISTOR CH 1/10W 33	1	
R6339	ERJ2GEJ512X	M.RESISTOR CH 1/16W 5.1K	1	
S6301	K0F212A00003	SWITCH	1	
S6302	K0F111A00539	SWITCH	1	
##	VEK0R19	CCD UNIT	1	(DMC-S1) E.S.D.
C3101	F1H1C105A097	C.CAPACITOR CH 16V 1U	1	
Q3101	DMS935E10R	TRANSISTOR	1	E.S.D.
R3101	ERJ2GEJ470X	M.RESISTOR CH 1/16W 47	1	
R3102	ERJ2GEJ222X	M.RESISTOR CH 1/16W 2.2K	1	
R3107	ERJ2GEJ132X	M.RESISTOR CH 1/16W 1.3K	1	
R3108	ERJ2GEJ220X	M.RESISTOR CH 1/16W 22	1	(DMC-S1)
TH3101	D4CC11030013	NTC THERMISTORS	1	
##	VEK0R37	CCD UNIT	1	(DMC-S3) E.S.D.
C3101	F1H1C105A097	C.CAPACITOR CH 16V 1U	1	
Q3101	DMS935E10R	TRANSISTOR	1	E.S.D.
R3101	ERJ2GEJ470X	M.RESISTOR CH 1/16W 47	1	

Ref.No.	Part No.	Part Name & Description	Pcs	Remarks
R3102	ERJ2GEJ222X	M.RESISTOR CH 1/16W 2.2K	1	
R3107	ERJ2GEJ132X	M.RESISTOR CH 1/16W 1.3K	1	
R3108	ERJ2GEJ470X	M.RESISTOR CH 1/16W 47	1	(DMC-S3)
TH3101	D4CC11030013	NTC THERMISTORS	1	

DMC-S1EB-K

Ref.No.	Part No.	Part Name & Description	Pcs	Remarks	Ref.No.	Part No.	Part Name & Description	Pcs	Remarks
1	VEP56128A	MAIN P.C.B.	1	(DMC-S1) E.S.D.	100	VXW1248	LENS UNIT (W/O CCD)	1	
1	VEP56128B	MAIN P.C.B.	1	(DMC-S3) E.S.D.	101	VEK0R19	CCD UNIT	1	(DMC-S1) E.S.D.
2	VEP58152A	FLASH P.C.B.	1	(RTL) E.S.D.	101	VEK0R37	CCD UNIT	1	(DMC-S3) E.S.D.
3	VEP58153A	TOP P.C.B.	1	(RTL)					
4	L0AA01A00107	SPEAKER	1		B1	VHD2281	SCREW	1	
5	B3ADB0000169	LIGHT EMITTING DEVICES	1	(D6301) E.S.D.	B2	VHD2281	SCREW	1	
6	EFN-AMCJ2ZD	FLASH UNIT	1		B3	VHD2281	SCREW	1	
△ 7	F2A2F4000002	E. CAPACITOR	1	(C8003)	B4	VHD2281	SCREW	1	
△ 8	ML-421S/DN	BUTTON BATTERY	1	(B6301) [ENERGY]	B5	VHD2312	SCREW	1	
9	VGQ0S01	TERMINAL COVER	1		B6	XQN16+BJ4FN	SCREW	1	
10	VGQ0S03	JACK COVER	1		B7	XQN14+BJ4FJK	SCREW	1	
11	VGQ0S42	CONDENSER SHEET	1		B8	XQN14+BJ4FJK	SCREW	1	
12	VGQ0S77	MIC SHEET	1		B9	XQN16+BJ4FN	SCREW	1	
13	VGQ0U76	SPEAKER SHEET	1		B10	XQN16+BJ4FN	SCREW	1	
14	VGQ0V26	SHADING SHEET	1		B11	VHD2198	SCREW	1	
16	VEK0R71	MAIN-FLASH FPC UNIT	1		B101	VHD1871	SCREW	1	
16-1	L0CBAY000090	MICROPHONE	1	(M9601)	B102	VHD1871	SCREW	1	
16-2	VGQ0V54	MIC FILM	1		B103	VHD1871	SCREW	1	
17	VKM8916	TRIPOD FRAME	1						
18	VMS8091	BATTERY DOOR SHAFT	1						
19	VYK4N98	LCD UNIT	1						
20	VYK4N99	REAR OPERATION UNIT	1						
21	K4ZZ01000292	OTHER TERMINALS	1						
22	K4ZZ01000292	OTHER TERMINALS	1						
23	K4ZZ01000292	OTHER TERMINALS	1						
24	VGQ0M78	BATTERY LOCK KNOB	1						
25	VKM9009	BATTERY CASE	1						
26	VMB4152	BATTERY LOCK SPRING	1						
27	VMB4450	BATTERY EJECT SPRING	1						
28	VMP9885	BATTERY FRAME	1						
29	VMP9882	FRAME PLATE A	1						
30	VYK4P03	FRONT CASE UNIT	1	S1/S3(-K) (EXCEPT S1P-K/S3P-K)					
30	VYK4Y70	FRONT CASE UNIT	1	S1(-PA) (EXCEPT S1P-PA)					
30	VYK4P05	FRONT CASE UNIT	1	S1(-A) (EXCEPT S1P-A)					
30	VYK4P02	FRONT CASE UNIT	1	S1(-S) (EXCEPT S1P-S)					
30	VYK4P04	FRONT CASE UNIT	1	S1(-P)					
30	VYK4S17	FRONT CASE UNIT	1	S1/S3(-W) (EXCEPT S3P-W)					
30	VYK4P10	FRONT CASE UNIT	1	S1P-A					
30	VYK4P08	FRONT CASE UNIT	1	S1P-K,S3P-K					
30	VYK4P11	FRONT CASE UNIT	1	S1P-N					
30	VYK4Y73	FRONT CASE UNIT	1	S1P-PA					
30	VYK4P07	FRONT CASE UNIT	1	S1P-S					
30	VYK4P21	FRONT CASE UNIT	1	S3(-A) (EXCEPT S3P-A)					
30	VYK4P20	FRONT CASE UNIT	1	S3(-R) (EXCEPT S3P-R)					
30	VYK4P22	FRONT CASE UNIT	1	S3(-V) (EXCEPT S3P-V)					
30	VYK4P16	FRONT CASE UNIT	1	S3P-A					
30	VYK4P15	FRONT CASE UNIT	1	S3P-R					
30	VYK4P17	FRONT CASE UNIT	1	S3P-V					
30	VYK4P13	FRONT CASE UNIT	1	S3P-W					
31	VKM8956	REAR CASE UNIT	1	(-K)					
31	VKM9382	REAR CASE UNIT	1	S1(-PA)					
31	VKM8958	REAR CASE UNIT	1	S1(-A)					
31	VKM8907	REAR CASE UNIT	1	S1(-S)					
31	VKM8957	REAR CASE UNIT	1	S1(-P)					
31	VKM9176	REAR CASE UNIT	1	(-W)					
31	VKM9140	REAR CASE UNIT	1	S1(-N)					
31	VKM9145	REAR CASE UNIT	1	S3(-A)					
31	VKM9143	REAR CASE UNIT	1	S3(-R)					
31	VKM9144	REAR CASE UNIT	1	S3(-V)					
32	VYK4P96	CURSOR BUTTON UNIT	1						
33	VYK4P34	BATTERY DOOR UNIT	1	(-K)					
33	VYK4Y72	BATTERY DOOR UNIT	1	S1(-PA)					
33	VYK4P36	BATTERY DOOR UNIT	1	S1(-A)					
33	VYK4P33	BATTERY DOOR UNIT	1	S1(-S)					
33	VYK4P35	BATTERY DOOR UNIT	1	S1(-P)					
33	VYK4S19	BATTERY DOOR UNIT	1	(-W)					
33	VYK4P37	BATTERY DOOR UNIT	1	S1P-N					
33	VYK4P41	BATTERY DOOR UNIT	1	S3(-A)					
33	VYK4P40	BATTERY DOOR UNIT	1	S3(-R)					
33	VYK4P42	BATTERY DOOR UNIT	1	S3(-V)					
34	VGU0H54	TOP BUTTON	1						
35	VKM8906	CENTER ORNAMENT	1	(DMC-S1)					
35	VKM9139	CENTER ORNAMENT	1	(DMC-S3)					
39	VMP9977	FRONT EARTH PLATE	1	(-S)					

DMC-S1EB-K

Ref.No.	Part No.	Part Name & Description	Pcs	Remarks	Ref.No.	Part No.	Part Name & Description	Pcs	Remarks
300	VPF1372	CAMERA BAG	1	EXCEPT P,PC,PU	△ 310	VQT3E40	BASIC O/I (ENGLISH)	1	GN
△ 301	DE-A92BA/SX	BATTERY CHARGER	1	GA,GC,GD,GF,GK	△ 310	VQT3E38	BASIC O/I (CHINESE(TRADITIONAL))	1	GT
△ 301	DE-A92CA/SX	BATTERY CHARGER	1	GT	△ 310	VQT3E24	BASIC O/I (SPANISH)	1	PR
△ 301	DE-A92DA/SX	BATTERY CHARGER	1	PR	330	VPK4710	PACKING CASE	1	S1EB-K,EE-K,EF-K,EG-K, EP-K,GA-K,GC-K,GD-K, GN-K,GT-K,PR-K [GD Needs GD LABEL]
△ 301	DE-A92AA/SX	BATTERY CHARGER	1	EB,EE,EF,EG,EP,GN	330	VPK4716	PACKING CASE	1	S1EB-PA,EE-PA,EG-PA, EP-PA,GA-P,GC-P,GD-P, GN-PA,GT-P,PR-PA [GD Needs GD LABEL]
302	K1HY08YY0017	USB CABLE W/PLUG	1	EXCEPT P,PC,PU	330	VPK4722	PACKING CASE	1	S1EE-A,EG-A,EP-A,GA-A, GC-A,GN-A
303	-----	BATTERY	1	EXCEPT P,PC,PU	330	VPK4704	PACKING CASE	1	S1EE-S,EG-S,EP-S,GA-S, GC-S,GN-S,GT-S,PR-S
305	VFC4297-B	HAND STRAP	1	EXCEPT P,PC,PU	330	VPK4878	PACKING CASE	1	S1GA-W,GC-W,GD-W,GN-W, GT-W [GD Needs GD LABEL]
△ 306	VFF0737-S	CD-ROM (SOFT/INSTRUCTION BOOK)	1	EB,EF,EG,EP [SPC] See "Notes"	330	VPK4723	PACKING CASE	1	S1GF-A
△ 306	VFF0738-S	CD-ROM (SOFT/INSTRUCTION BOOK)	1	EE [SPC] See "Notes"	330	VPK4711	PACKING CASE	1	S1GF-K
△ 306	VFF0739-S	CD-ROM (SOFT/INSTRUCTION BOOK)	1	GA,GC,GD,GF,GN,GT [SPC] See "Notes"	330	VPK4717	PACKING CASE	1	S1GF-P
△ 306	VFF0740-S	CD-ROM (SOFT/INSTRUCTION BOOK)	1	GK [SPC] See "Notes"	330	VPK4705	PACKING CASE	1	S1GF-S
△ 306	VFF0736-S	CD-ROM (SOFT/INSTRUCTION BOOK)	1	PR [SPC] See "Notes"	330	VPK4879	PACKING CASE	1	S1GF-W
308	VPF1378	BAG, POLYETHYLENE	1	EXCEPT P,PC,PU	330	VPK4712	PACKING CASE	1	S1GK-K
309	VQC8060	O/I SOFTWARE (ENGLISH)	1	EB,GN	330	VPK4706	PACKING CASE	1	S1GK-S
309	VQC8061	O/I SOFTWARE (RUSSIAN/UKRAINIAN)	1	EE	330	VPK4880	PACKING CASE	1	S1GK-W
309	VQC8059	O/I SOFTWARE (FRENCH)	1	EF	330	VPK4747	PACKING CASE	1	S3EB-A,EE-A,EG-A,EP-A, GA-A,GC-A,GN-A
309	VQC8057	O/I SOFTWARE (GERMAN/FRENCH/ITALIAN/ DUTCH/SPANISH/ PORTUGUESE/TURKISH)	1	EG	330	VPK4732	PACKING CASE	1	S3EB-K,EE-K,EF-K,EG-K, EP-K,GA-K,GC-K,GD-K, GN-K,GT-K,PR-K [GD Needs GD LABEL]
309	VQC8058	O/I SOFTWARE (FINNISH/SWEDISH/DANISH/ POLISH/CZECH/HUNGARIAN)	1	EP	330	VPK4742	PACKING CASE	1	S3EB-R,EE-R,EF-R,EG-R, EP-R,GA-R,GC-R,GN-R, GT-R,PR-R
309	VQC8062	O/I SOFTWARE (ENGLISH/ CHINESE(TRADITIONAL)/ ARABIC/PERSIAN)	1	GA,GC,GF	330	VPK4752	PACKING CASE	1	S3EB-V,EF-V,EG-V,EP-V, GA-V,GC-V,GN-V
309	VQC8068	O/I SOFTWARE (KOREAN)	1	GD	330	VPK4737	PACKING CASE	1	S3EB-W,EE-W,EF-W,EG-W, EP-W,GA-W,GC-W,GD-W, GN-W,GT-W,PR-W [GD Needs GD LABEL]
309	VQC8064	O/I SOFTWARE (CHINESE(SIMPLIFIED))	1	GK	330	VPK4748	PACKING CASE	1	S3GF-A
309	VQC8063	O/I SOFTWARE (CHINESE(TRADITIONAL))	1	GT	330	VPK4733	PACKING CASE	1	S3GF-K
309	VQC8056	O/I SOFTWARE (SPANISH/PORTUGUESE)	1	PR	330	VPK4743	PACKING CASE	1	S3GF-R
△ 310	VQT3E33	BASIC O/I (ENGLISH)	1	EB	330	VPK4753	PACKING CASE	1	S3GF-V
△ 310	VQT3E34	BASIC O/I (RUSSIAN/UKRAINIAN)	1	EE	330	VPK4738	PACKING CASE	1	S3GF-W
△ 310	VQT3E32	BASIC O/I (FRENCH)	1	EF	330	VPK4749	PACKING CASE	1	S3GK-A
△ 310	VQT3E25	BASIC O/I (GERMAN/FRENCH)	1	EG	330	VPK4734	PACKING CASE	1	S3GK-K
△ 310	VQT3E26	BASIC O/I (ITALIAN/DUTCH)	1	EG	330	VPK4744	PACKING CASE	1	S3GK-R
△ 310	VQT3E27	BASIC O/I (SPANISH/PORTUGUESE)	1	EG	330	VPK4754	PACKING CASE	1	S3GK-V
△ 310	VQT3E28	BASIC O/I (TURKISH)	1	EG	330	VPK4739	PACKING CASE	1	S3GK-W
△ 310	VQT3E29	BASIC O/I (SWEDISH/DANISH)	1	EP	331	VPN7170	CUSHION	1	except P,PC,PU
△ 310	VQT3E30	BASIC O/I (POLISH/CZECH)	1	EP	332	VQL2J61	GD LABEL FOR INNER CARTON	1	GD
△ 310	VQT3E31	BASIC O/I (HUNGARIAN/FINNISH)	1	EP	333	VQL2C68-1A	OPERATING LABEL	1	GT
△ 310	VQT3E35	BASIC O/I (ENGLISH/ CHINESE(TRADITIONAL))	1	GA,GC,GF	△ 350	K2CA2Y00130	AC CORD W/PLUG	1	GK
△ 310	VQT3M11	BASIC O/I (VIETNAMESE)	1	GA	△ 350	K2CA2Y00129	AC CORD W/PLUG	1	GT
△ 310	VQT3E37	BASIC O/I (ARABIC/PERSIAN)	1	GC,GF	△ 352	K2CJ2Y00052	AC CORD W/PLUG	1	GN
△ 310	VQT3E41	BASIC O/I (KOREAN)	1	GD	△ 353	K2CJ2Y00053	AC CORD W/PLUG	1	PR
△ 310	VQT3E39	BASIC O/I (CHINESE(SIMPLIFIED))	1	GK	△ 354	K2CQ2Y00082	AC CORD W/PLUG	1	EE,EF,EG,EP,GA,GF
					△ 354	K2CR2Y00026	AC CORD W/PLUG	1	GD
					△ 356	K2CT3Y00034	AC CORD W/PLUG	1	EB,GC

S7. Exploded View

S7.1. Frame and Casing Section

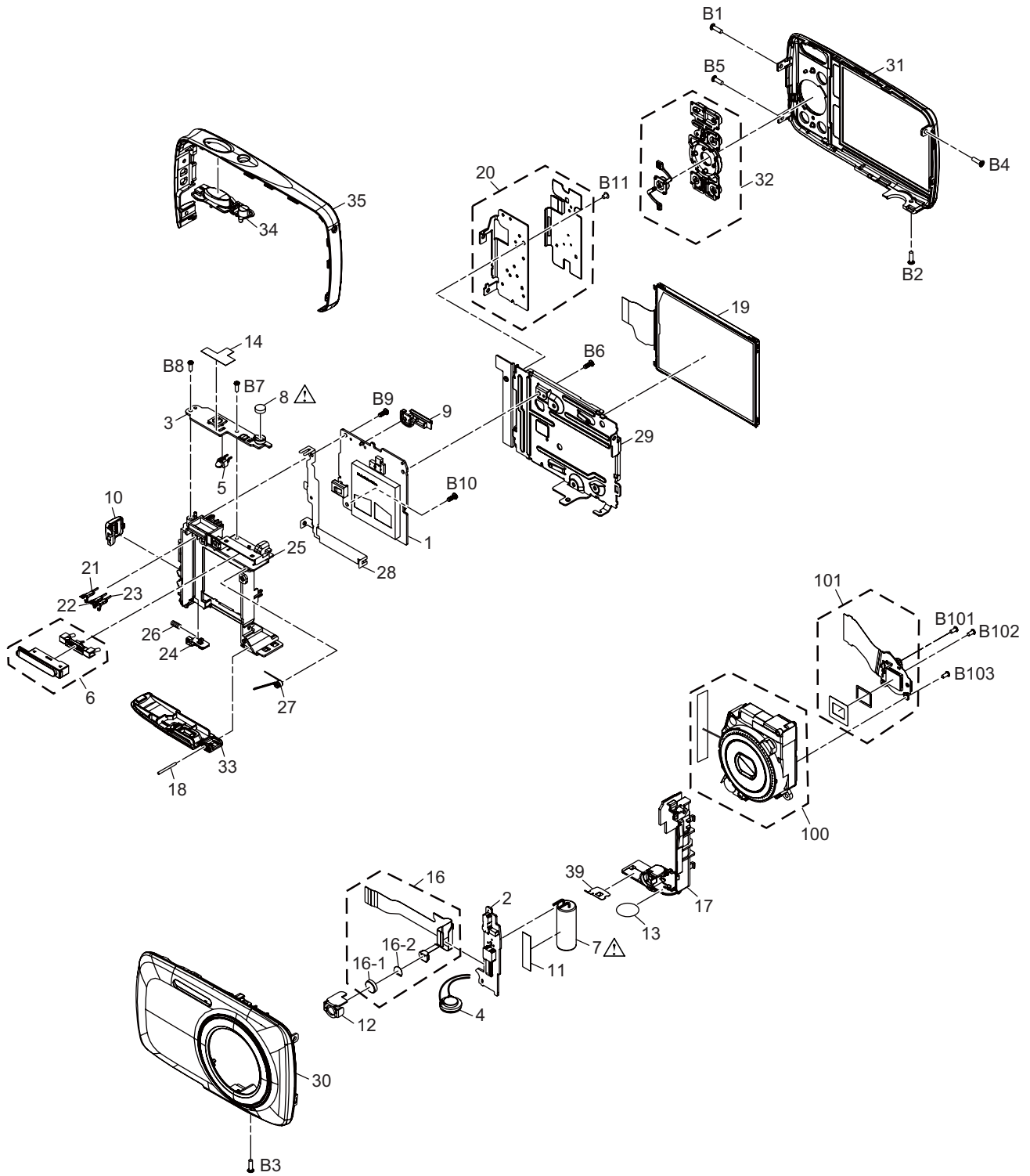

S7.2. Packing Parts and Accessories Section (1)

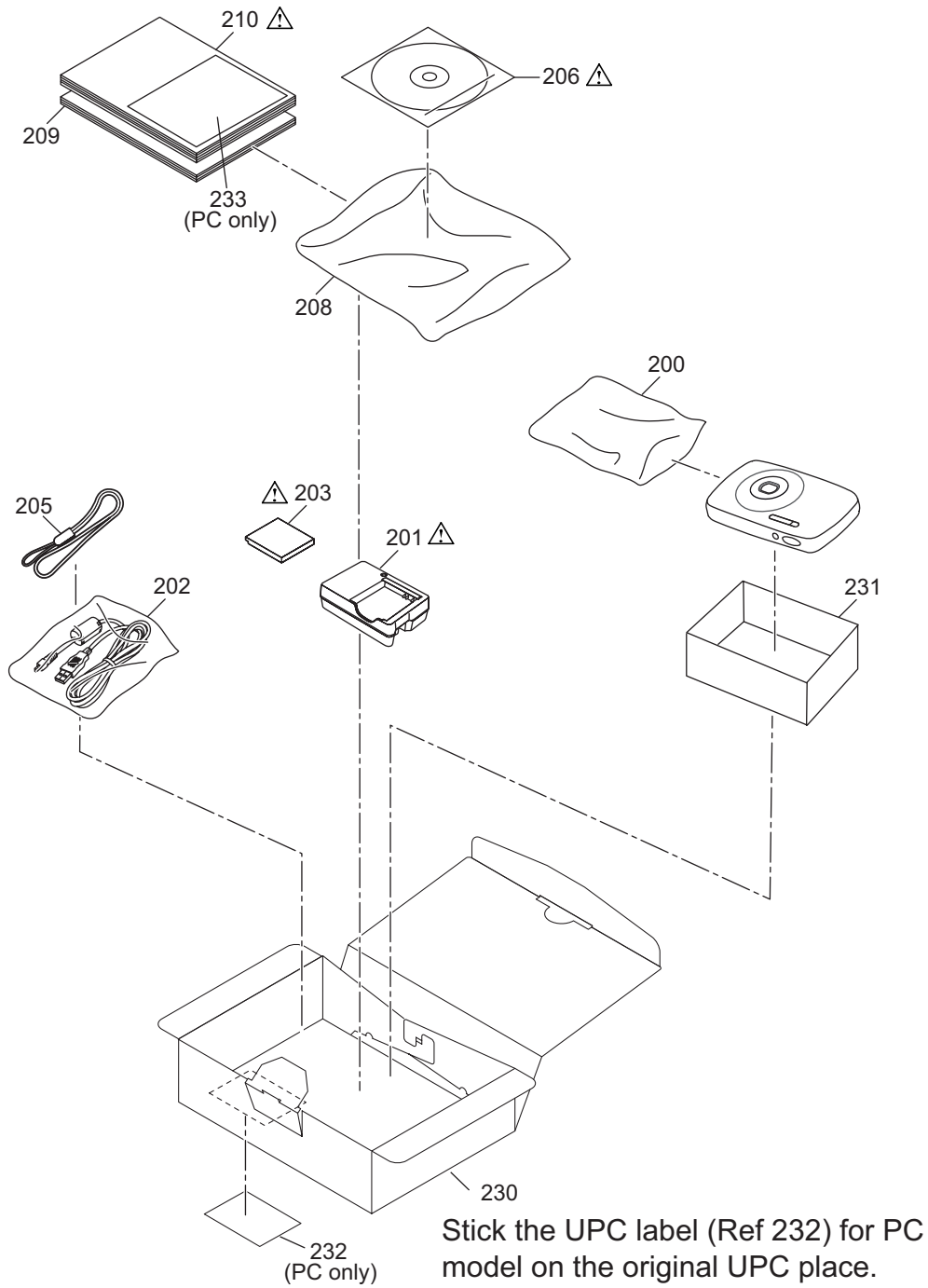

S7.3. Packing Parts and Accessories Section (2)

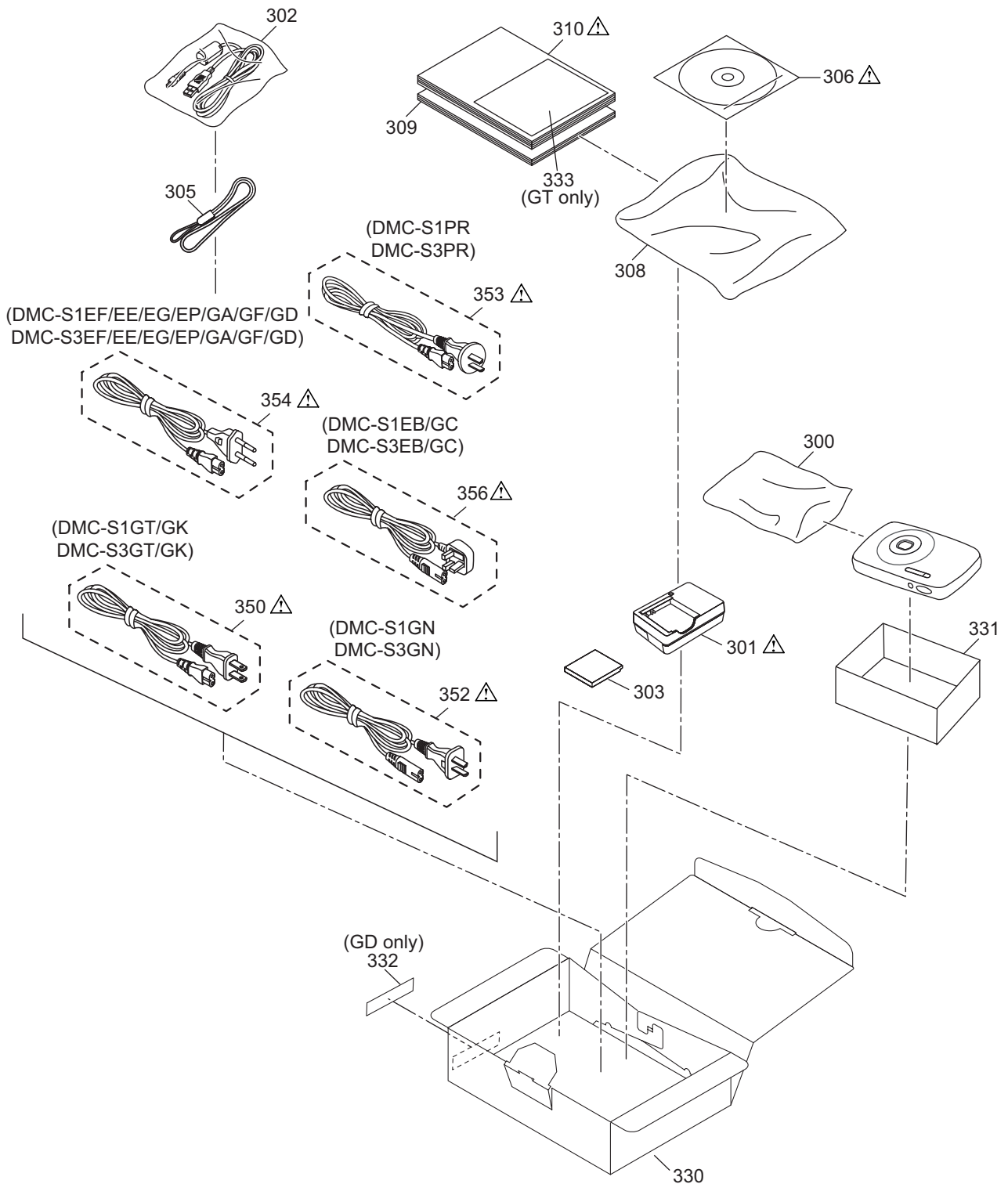

Stick the UPC label (Ref 332) for GD model on the original UPC place.