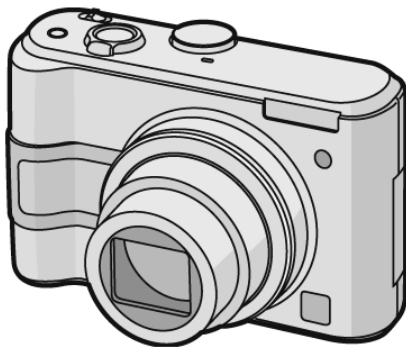

Service Manual

Digital Camera

LUMIX

DMC-LZ3PP
DMC-LZ3PL
DMC-LZ3EB
DMC-LZ3EE
DMC-LZ3EF
DMC-LZ3EG
DMC-LZ3EGM
DMC-LZ3GC
DMC-LZ3GK
DMC-LZ3GN
DMC-LZ3GT
DMC-LZ4PP
DMC-LZ4EB
DMC-LZ4EG
DMC-LZ5PP
DMC-LZ5PL
DMC-LZ5EB
DMC-LZ5EE
DMC-LZ5EF
DMC-LZ5EG
DMC-LZ5EGM
DMC-LZ5GC
DMC-LZ5GK
DMC-LZ5GN
DMC-LZ5GT
DMC-LZ5SG

Panasonic[®]

DMC-LZ5SEPP

Vol. 1

Colour

DMC-LZ3

(S).....Silver Type

DMC-LZ4

(S).....Silver Type

DMC-LZ5

(S).....Silver Type (except SEPP)

(K).....Black Type (except PL/GK/GT/SG/SEPP)

(H).....Glaz Type (only EE/SEPP)

WARNING

This service information is designed for experienced repair technicians only and is not designed for use by the general public. It does not contain warnings or cautions to advise non-technical individuals of potential dangers in attempting to service a product. Products powered by electricity should be serviced or repaired only by experienced professional technicians. Any attempt to service or repair the product or products dealt with in this service information by anyone else could result in serious injury or death.

TABLE OF CONTENTS

	PAGE	PAGE
1 Safety Precaution	3	
1.1. General Guidelines	3	
1.2. Leakage Current Cold Check	3	
1.3. Leakage Current Hot Check (See Figure 1.)	3	
1.4. How to Discharge the Capacitor on Flash Top PCB	4	
2 Warning	5	
2.1. Prevention of Electro Static Discharge (ESD) to Electrostatically Sensitive (ES) Devices	5	
2.2. How to Replace the Lithium Battery	6	
3 Service Navigation	8	
3.1. Introduction	8	
3.2. General Description About Lead Free Solder (PbF)	8	
3.3. Important Notice 1:(Other than U.S.A. and Canadian Market)	8	
3.4. How to Define the Model Suffix (NTSC or PAL model)	9	
4 Specifications	11	
5 Location of Controls and Components	12	
6 Service Mode	13	
6.1. Error Code Memory Function	13	
6.2. Confirmation of Firmware Version	16	
7 Service Fixture & Tools	17	
7.1. Service Fixture and Tools	17	
7.2. When Replacing the Main PCB	17	
7.3. Service Position	18	
8 Disassembly and Assembly Instructions	19	
8.1. Disassembly Flow Chart	19	
8.2. PCB Location	19	
8.3. Disassembly Procedure	20	
8.4. Disassembly Procedure for the Lens	24	
8.5. Assembly Procedure for the Lens	26	
8.6. Removal of the CCD	27	
9 Measurements and Adjustments	28	
9.1. Matrix Chart for Replaced Part and Necessary Adjustment	28	
10 Maintenance	29	
10.1. Cleaning Lens and LCD Panel	29	

1 Safety Precaution

1.1. General Guidelines

1. IMPORTANT SAFETY NOTICE

There are special components used in this equipment which are important for safety. These parts are marked by

⚠ in the Schematic Diagrams, Circuit Board Layout, Exploded Views and Replacement Parts List. It is essential that these critical parts should be replaced with manufacturer's specified parts to prevent X-RADIATION, shock, fire, or other hazards. Do not modify the original design without permission of manufacturer.

2. An Isolation Transformer should always be used during the servicing of AC Adaptor whose chassis is not isolated from the AC power line. Use a transformer of adequate power rating as this protects the technician from accidents resulting in personal injury from electrical shocks. It will also protect AC Adaptor from being damaged by accidental shorting that may occur during servicing.
3. When servicing, observe the original lead dress. If a short circuit is found, replace all parts which have been overheated or damaged by the short circuit.
4. After servicing, see to it that all the protective devices such as insulation barriers, insulation papers shields are properly installed.
5. After servicing, make the following leakage current checks to prevent the customer from being exposed to shock hazards.

1.2. Leakage Current Cold Check

1. Unplug the AC cord and connect a jumper between the two prongs on the plug.
2. Measure the resistance value, with an ohmmeter, between the jumpered AC plug and each exposed metallic cabinet part on the equipment such as screwheads, connectors, control shafts, etc. When the exposed metallic part has a return path to the chassis, the reading should be between $1\text{ M}\Omega$ and $5.2\text{ M}\Omega$. When the exposed metal does not have a return path to the chassis, the reading must be infinity.

1.3. Leakage Current Hot Check (See Figure 1.)

1. Plug the AC cord directly into the AC outlet. Do not use an isolation transformer for this check.
2. Connect a $1.5\text{ k}\Omega$, 10 W resistor, in parallel with a $0.15\text{ }\mu\text{F}$ capacitor, between each exposed metallic part on the set and a good earth ground, as shown in Figure 1.
3. Use an AC voltmeter, with $1\text{ k}\Omega/\text{V}$ or more sensitivity, to measure the potential across the resistor.
4. Check each exposed metallic part, and measure the voltage at each point.
5. Reverse the AC plug in the AC outlet and repeat each of the above measurements.
6. The potential at any point should not exceed 0.75 V RMS . A leakage current tester (Simpson Model 229 or equivalent) may be used to make the hot checks, leakage current must not exceed $1/2\text{ mA}$. In case a measurement is outside of the limits specified, there is a possibility of a shock hazard, and the equipment should be repaired and rechecked before it is returned to the customer.

Hot-Check Circuit



Figure. 1

1.4. How to Discharge the Capacitor on Flash Top PCB

CAUTION:

1. Be sure to discharge the capacitor on FLASH TOP PCB.
2. Be careful of the high voltage circuit on FLASH TOP PCB when servicing.

[Discharging Procedure]

1. Refer to the disassemble procedure and Remove the necessary parts/unit.
2. Put the insulation tube onto the lead part of Resistor (ERG5SJ102:1k Ω /5W).
(an equivalent type of resistor may be used.)
3. Put the resistor between both terminals of capacitor on FLASH TOP PCB for approx. 5 seconds.
4. After discharging confirm that the capacitor voltage is lower than 10V using a voltmeter.

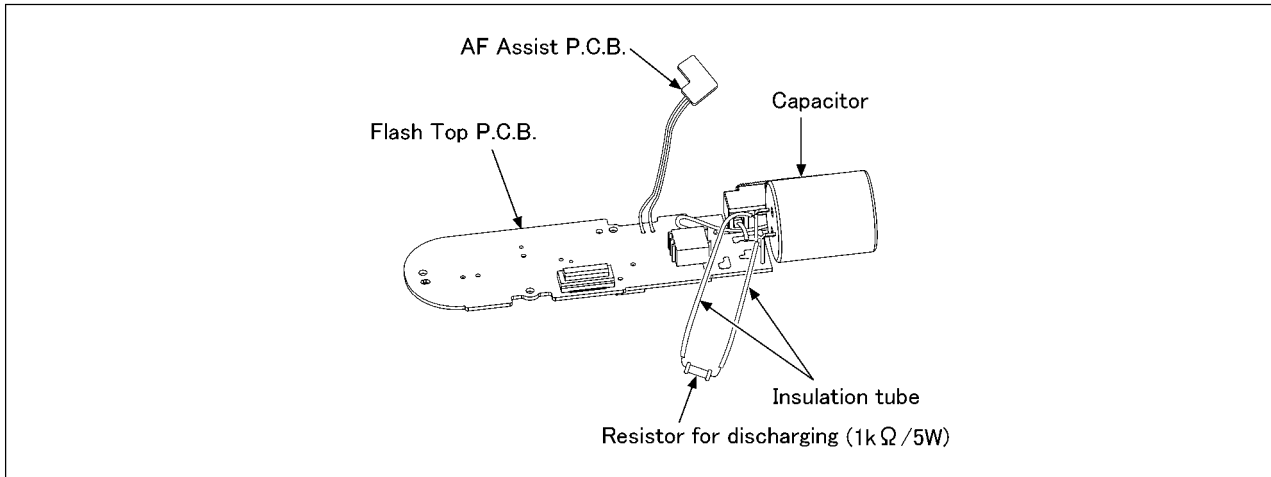

Fig. F1

2 Warning

2.1. Prevention of Electro Static Discharge (ESD) to Electrostatically Sensitive (ES) Devices

Some semiconductor (solid state) devices can be damaged easily by static electricity. Such components commonly are called Electrostatically Sensitive (ES) Devices.

Examples of typical ES devices are CCD image sensor, IC (integrated circuits) and some field-effect transistors and semiconductor "chip" components.

The following techniques should be used to help reduce the incidence of component damage caused by electro static discharge (ESD).

1. Immediately before handling any semiconductor component or semiconductor-equipped assembly, drain off any ESD on your body by touching a known earth ground. Alternatively, obtain and wear a commercially available discharging ESD wrist strap, which should be removed for potential shock reasons prior to applying power to the unit under test.
2. After removing an electrical assembly equipped with ES devices, place the assembly on a conductive surface such as aluminum foil, to prevent electrostatic charge buildup or exposure of the assembly.
3. Use only a grounded-tip soldering iron to solder or unsolder ES devices.
4. Use only an antistatic solder removal device. Some solder removal devices not classified as "antistatic (ESD protected)" can generate electrical charge sufficient to damage ES devices.
5. Do not use freon-propelled chemicals. These can generate electrical charges sufficient to damage ES devices.
6. Do not remove a replacement ES device from its protective package until immediately before you are ready to install it. (Most replacement ES devices are packaged with leads electrically shorted together by conductive foam, aluminum foil or comparable conductive material).
7. Immediately before removing the protective material from the leads of a replacement ES device, touch the protective material to the chassis or circuit assembly into which the device will be installed.

CAUTION :

Be sure no power is applied to the chassis or circuit, and observe all other safety precautions.

8. Minimize bodily motions when handling unpackaged replacement ES devices. (Otherwise harmless motion such as the brushing together of your clothes fabric or the lifting of your foot from a carpeted floor can generate static electricity (ESD) sufficient to damage an ES device).

2.2. How to Replace the Lithium Battery

2.2.1. Replacement Procedure

1. Remove the Main PCB (Refer to Disassembly Procedures.)
2. Remove the Lithium battery (Ref. No. "Z9101" at component side of Main PCB) and then replace it into new one.

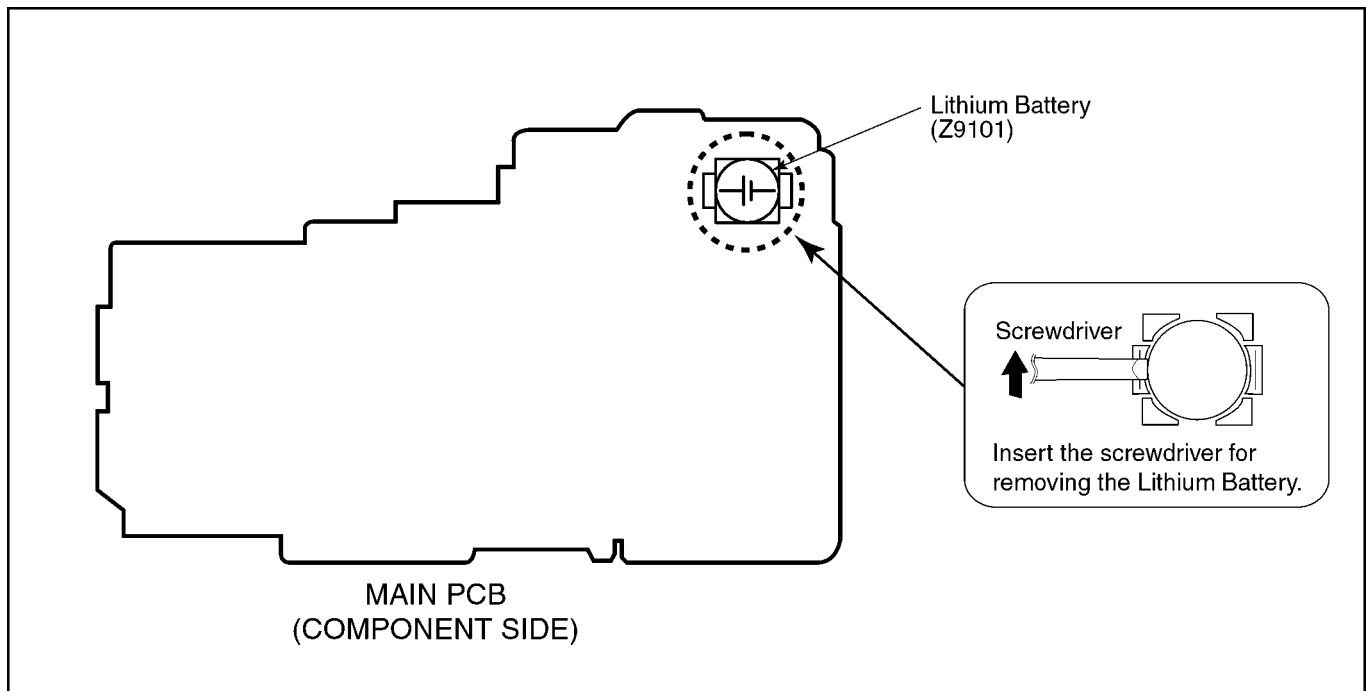

NOTE:

This Lithium battery is a critical component.

(Type No.: ML-614S/ZT **Manufactured by Matsushita Battery Industrial Co.,Ltd.**)

It must never be subjected to excessive heat or discharge.

It must therefore only be fitted in requirement designed specifically for its use.

Replacement batteries must be of same type and manufacture.

They must be fitted in the same manner and location as the original battery, with the correct polarity contacts observed.

Do not attempt to re-charge the old battery or re-use it for any other purpose.

It should be disposed of in waste products destined for burial rather than incineration.

(For English)

CAUTION

Danger of explosion if battery is incorrectly replaced.
Replace only with the same or equivalent type recommended by the manufacturer.
Dispose of used batteries according to the manufacturer's instructions.

(For French)

PRECAUTION

Le fait de remplacer incorrectement la pile peut présenter des risques d'explosion.
Remplacer la pile uniquement par une pile identique ou de type équivalent recommandée par le fabricant. Se débarrasser des piles usagées conformément aux instructions du fabricant.

(For German)

VORSICHT

Bei einer falsch eingesetzten Batterie besteht Explosionsgefahr. Nur mit einer vom Hersteller empfohlenen Batterie vom gleichen Typ ersetzen.
Verbrauchte Batterien beim Fachhändler oder einer Sammelstelle für Sonderstoffe abliefern.

(For Swedish)

VARNING

Explosionsfara vid felaktigt batteribyte.
Använd samma batterityp eller en ekvivalent typ som rekommenderas av apparatillverkaren.
Kassera använt batteri enligt fabrikantens instruktion.

(For Norwegian)

ADVARSEL!

Lithiumbatteri-Eksplosionsfare ved feilagtig håndtering.
Udskiftning må kun ske med batteri af samme fabrikat og type.
Levér det brugte batteri tilbage til leverandøren.

(For Finnish)

VAROITUS

Paristo voi räjähtää, jos se on virheellisesti asennettu.
Vaihda paristo ainoastaan laitevalmistajan suositteluun tyyppiin.
Hävitä käytetty paristo valmistajan ohjeiden mukaisesti.

NOTE:

Above caution are also applicable for below batteries which is for DMC-LZ3/LZ4/LZ5 all series, as well.

1. AA Oxiride batteries
2. AA Alkaline batteries
3. AA Rechargeable Ni-MH (nickel-metal hydride) batteries

3 Service Navigation

3.1. Introduction

This service manual contains technical information, which allow service personnel's to understand and service this model. Please place orders using the parts list and not the drawing reference numbers.

If the circuit is changed or modified, the information will be followed by service manual to be controlled with original service manual.

3.2. General Description About Lead Free Solder (PbF)

The lead free solder has been used in the mounting process of all electrical components on the printed circuit boards used for this equipment in considering the globally environmental conservation.

The normal solder is the alloy of tin (Sn) and lead (Pb). On the other hand, the lead free solder is the alloy mainly consists of tin (Sn), silver (Ag) and Copper (Cu), and the melting point of the lead free solder is higher approx.30°C (86°F) more than that of the normal solder.

Distinction of PCB Lead Free Solder being used

The letter of "PbF" is printed either foil side or components side on the PCB using the lead free solder.(See right figure)

PbF

Service caution for repair work using Lead Free Solder (PbF)

- The lead free solder has to be used when repairing the equipment for which the lead free solder is used.
(Definition: The letter of "PbF" is printed on the PCB using the lead free solder.)
- To put lead free solder, it should be well molten and mixed with the original lead free solder.
- Remove the remaining lead free solder on the PCB cleanly for soldering of the new IC.
- Since the melting point of the lead free solder is higher than that of the normal lead solder, it takes the longer time to melt the lead free solder.
- Use the soldering iron (more than 70W) equipped with the temperature control after setting the temperature at 350±30°C (662±86°F).

Recommended Lead Free Solder (Service Parts Route.)

- The following 3 types of lead free solder are available through the service parts route.
RFKZ03D01K------(0.3mm 100g Reel)
RFKZ06D01K------(0.6mm 100g Reel)
RFKZ10D01K------(1.0mm 100g Reel)

Note

* Ingredient: tin (Sn) 96.5%, silver (Ag) 3.0%, Copper (Cu) 0.5%, Cobalt (Co) / Germanium (Ge) 0.1 to 0.3%

3.3. Important Notice 1:(Other than U.S.A. and Canadian Market)

1. The service manual does not contain the following information, because of the impossibility of servicing at component level without concerned equipment/facilities.
 - a. Schematic diagram, Block Diagram and PCB layout of Main PCB.
 - b. Parts list for individual parts of Main PCB.When a part replacement is required for repairing Main PCB, replace as an assembled parts. (Main PCB)
2. The following category is/are recycle module part. please send it/them to Central Repair Center.
 - MAIN PCB (DMC-LZ3/LZ4: VEP56028A, DMC-LZ5: VEP56028B) : Excluding replacement of Lithium Battery

3.4. How to Define the Model Suffix (NTSC or PAL model)

There are six kinds of DMC-LZ3/LZ4/LZ5, regardless of the colours.





- a) DMC-LZ5S
- b) DMC-LZ3PP, LZ4PP, LZ5PP/SEPP
- c) DMC-LZ3EB/EF/EG/EGM/GN, LZ4EB/EG, LZ5EB/EF/EG/EGM/GN
- d) DMC-LZ3EE, LZ5EE
- e) DMC-LZ3GT, LZ5GT
- f) DMC-LZ3PL/GC/GK, LZ5PL/GC/GK/SG

(DMC-LZ5S is exclusively Japan domestic model.)

What is the difference is that the "INITIAL SETTINGS" data which is stored in Flash ROM mounted on Main PCB.

3.4.1. Defining methods:

To define the model suffix to be serviced, refer to the nameplate which is putted on the bottom side of the Unit.

<p>a) DMC-LZ5S DMC-LZ5S is exclusively Japan domestic model.</p> <p>b) DMC-LZ3PP, LZ4PP, LZ5PP/SEPP The nameplate for these models show the following Safty registration mark.</p> <div style="border: 1px solid black; padding: 5px; text-align: center;">  </div> <p>c) DMC-LZ3EB/EF/EG/EGM/GN, LZ4EB,EG/LZ5EB/EF/EG/EGM/GN The nameplate for these models show the following Safty registration mark.</p> <div style="border: 1px solid black; padding: 5px; text-align: center;">  </div> <p>d) DMC-LZ3EE, LZ5EE The nameplate for these models show the following Safty registration mark.</p> <div style="border: 1px solid black; padding: 5px; text-align: center;">  </div> <p>e) DMC-LZ3GT, LZ5GT The nameplate for these models show the following Safty registration mark.</p> <div style="border: 1px solid black; padding: 5px; text-align: center;">  </div> <p>f) DMC-LZ3PL/GC/GK, LZ5PL/GC/GK/SG The nameplate for these models do not show any above Safty registration mark.</p>	 <p style="text-align: center; border: 1px solid black; padding: 2px; display: inline-block;">Safty registration mark</p>
---	--

NOTE:

After replacing the MAIN PCB, be sure to achieve adjustment.

The adjustment instruction is available at "software download" on the "Support Information from NWBG/VDBG-PAVC" web-site in "TSN system", together with Maintenance software.

3.4.2. INITIAL SETTINGS:

CAUTION:

The unit employs "Built-in Memory" for picture image data recording. (Approx.14MB)
Be sure to make picture data back up (i.e., Copying to SD memory card), before proceeding "INITIAL SETTINGS".
Once "INITIAL SETTINGS" has been carried out, all image data belong to "Built-in Memory" shall be erased.

CAUTION:

NEVER select "NONE(JAPAN)" if the unit is other than "JAPAN" model.
Other-wise, it can not be reset to the others.

When you replace the Main PCB be sure to perform the initial settings after achieving the Adjustment, by ordering the following procedure in accordance with model suffix.

• Step 1. The temporary cancellation of factory setting:

Set the mode dial to "[Normal picture mode] (Red camera mark)".

While keep pressing [Optical Image Stabilizer] and "[UP] of Cross key" simultaneously, turn the Power on.

• Step 2. The cancellation of factory setting:

Set the mode dial to "[Playback]".

Press [Optical Image Stabilizer] and "[UP] of Cross key" simultaneously, then turn the Power off.

• Step 3. Turn the Power on:

Set the mode dial to "[Normal picture mode] (Red camera mark)", and then turn the Power on.

• Step 4. Display the INITIAL SETTING:

While keep pressing [MENU] and "[RIGHT] of Cross key" simultaneously, turn the Power off.

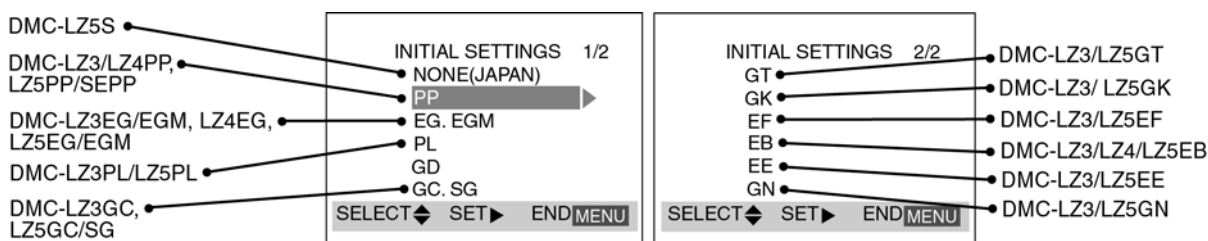

• Step 5. Set the INITIAL SETTING:

Select the area with pressing "[UP] / [DOWN] of Cross key", and then press the "[RIGHT] of Cross key".

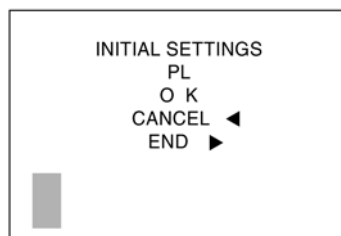

The only set area is displayed, and then press the "[RIGHT] of Cross key" after confirmation.

(The unit is powered off automatically.)

Confirm the display of "PLEASE SET THE CLOCK" in English when the unit is turned on again.

• Step 6. CONFIRMATION:

The display shows "PLEASE SET THE CLOCK" when turn the Power on again.

When the unit is connected to PC with USB cable, it is detected as removable media.

(When the "GT" or "GK" model suffix is selected, the display shows "PLEASE SET THE CLOCK" in Chinese.)

1) As for your reference Default setting condition is given in the following table.

• Default setting (After "INITIAL SETTINGS")

	MODEL	VIDEO OUTPUT	LANGUAGE	DATE	REMARKS
a)	DMC-LZ5S	NTSC	Japanese	Year/Month/Date	
b)	DMC-LZ3PP/PL, LZ4PP, LZ5PP/PL/SEPP	NTSC	English	Month/Date/Year	
c)	DMC-LZ3EB/EE/EF/EG/EGM/GC/GN, DMC-LZ4EB/EG, DMC-LZ5EB/EE/EF/EG/EGM/GC/GN/SG,	PAL	English	Date/Month/Year	
d)	DMC-LZ3GK, LZ5GK	PAL	Chinese (simplified)	Year/Month/Date	
e)	DMC-LZ3GT, LZ5GT	NTSC	Chinese (traditional)	Year/Month/Date	

4 Specifications

Digital Camera: Information for your safety

Power Source:	DC 3.0 V
Power Consumption:	DMC-LZ5: 1.5 W (When recording) 0.7 W (When playing back)
	DMC-LZ4: DMC-LZ3: 1.4 W (When recording) 0.7 W (When playing back)

Camera effective pixels: 6,000,000 pixels (DMC-LZ5)/5,000,000 pixels (DMC-LZ4/DMC-LZ3)

Image sensor: 1/2.5" CCD, total pixel number 6,370,000 pixels (DMC-LZ5)/5,360,000 pixels (DMC-LZ4/DMC-LZ3), Primary color filter

Lens: Optical 6× zoom, f=6.1 mm to 36.6 mm (35 mm film camera equivalent: 37 mm to 222 mm)/F2.8 to F4.5

Digital zoom: Max. 4×

Extended optical zoom: Max. 8.3× (DMC-LZ5)/Max. 7.5× (DMC-LZ4/DMC-LZ3) (Except for the maximum picture size for each aspect ratio)

Focus: Normal/Macro, 5-area-focusing/3-area-focusing (High speed)/1-area-focusing (High speed)/1-area-focusing/Spot-focusing

Focus range: Normal: 50 cm (1.64 feet) (Wide)/1.2 m (3.94 feet) (Tele) to ∞
Macro/Simple/Motion picture: 5 cm (0.16 feet) (Wide)/50 cm (1.64 feet) (Tele) to ∞

Shutter system: Electronic shutter+Mechanical shutter

Burst recording

Burst speed: 3 frames/second (High speed), 2 frames/second (Low speed), Approx. 1.5 frames/second (Unlimited)

Number of recordable pictures: Max. 8 frames (Standard) (DMC-LZ5), max. 6 frames (Fine), (DMC-LZ5), Max. 5 frames (Standard) (DMC-LZ4/DMC-LZ3), max. 3 frames (Fine) (DMC-LZ4/DMC-LZ3), Depends on the remaining capacity of the built-in memory or the card (Unlimited).
(Performance in burst recording is only with SD Memory Card. MultiMediaCard performance will be less.)

Motion picture recording: 640×480 pixels (Only when using an SD Memory Card)/320×240 pixels (30 or 10 frames/second with audio. The maximum recording time depends on the capacity of the built-in memory or the card. Audio recording is available only with DMC-LZ5.)

ISO sensitivity: AUTO/80/100/200/400
[HIGH SENS.] mode: 800 to 1600

Shutter speed: 8 to 1/2000th
[STARRY SKY] mode: 15 seconds, 30 seconds, 60 seconds
Motion picture mode: 1/30th to 1/20000th

White balance: AUTO/Daylight/Cloudy/Halogen/White set

Exposure (AE): Program AE
Exposure compensation (1/3 EV Step, -2 EV to +2 EV)

Metering mode: Multiple

LCD monitor: 2.5" (DMC-LZ5/DMC-LZ4)/2.0" (DMC-LZ3) low-temperature polycrystalline TFT LCD (Approx. 85,000 pixels) (field of view ratio about 100%)

Flash: Flash range: (ISO AUTO)
Approx. 50 cm (1.64 feet) to 4.2 m (13.8 feet) (Wide) [HIGH SENS.] mode: Approx. 80 cm (2.62 feet) to 5.7 m (18.7 feet)
AUTO, AUTO/Red-eye reduction, Forced ON (Forced ON/Red-eye reduction), Slow sync./Red-eye reduction, Forced OFF

Microphone (DMC-LZ5): Monaural

Recording media: Built-in Memory (Approx. 14 MB)/SD Memory Card/ MultiMediaCard (Still pictures only)

Picture size

Still picture: When the aspect ratio setting is [4:3]
2816×2112 pixels (DMC-LZ5), 2560×1920 pixels (DMC-LZ4/DMC-LZ3), 2048×1536 pixels, 1600×1200 pixels, 1280×960 pixels, 640×480 pixels
When the aspect ratio setting is [3:2]
2816×1880 pixels (DMC-LZ5), 2560×1712 pixels (DMC-LZ4/DMC-LZ3), 2048×1360 pixels
When the aspect ratio setting is [16:9]
2816×1584 pixels (DMC-LZ5), 2560×1440 pixels (DMC-LZ4/DMC-LZ3), 1920×1080 pixels
640×480 pixels (Only when using an SD Memory Card)/320×240 pixels
Fine/Standard

Motion pictures:

Quality:

Recording file format

Still Picture: JPEG (based on Design rule for Camera File system, based on Exif 2.2 standard)/DPOF corresponding

Picture with audio (DMC-LZ5): JPEG (based on Design rule for Camera File system, based on Exif 2.2 standard)+QuickTime (picture with audio)

Motion pictures: QuickTime Motion JPEG (Audio recording is available on DMC-LZ5)

Interface

Digital: USB 2.0 (Full Speed)

Analog video/audio (DMC-LZ5):

Analog video (DMC-LZ4/DMC-LZ3): NTSC/PAL Composite (Switched by menu), Audio line output (monaural) (DMC-LZ5)

Terminal

DIGITAL/AV OUT (DMC-LZ5):

DIGITAL/V.OUT (DMC-LZ4/DMC-LZ3): Dedicated jack (8 pin)

DC IN: Dedicated jack

Dimensions: Approx. 100.0 mm (W)×62.0 mm (H)×45.0 mm (D) [3 15/16" (W)×2 7/16" (H)×1 13/16" (D)] (excluding the projection part)

Mass: Approx. 186 g/6.56 oz (DMC-LZ5/DMC-LZ4), Approx. 183 g/6.45 oz (DMC-LZ3) (excluding card and batteries), Approx. 234 g/8.25 oz (DMC-LZ5/DMC-LZ4), Approx. 231 g/8.15 oz (DMC-LZ3) (with card and batteries)

Operating temperature: 0°C to 40 °C (32 °F to 104 °F)

Operating humidity: 10% to 80%

5 Location of Controls and Components

Names of the Components

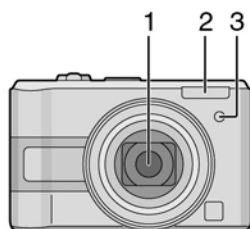

- 1 Lens
- 2 Flash
- 3 Self-timer indicator
AF assist lamp

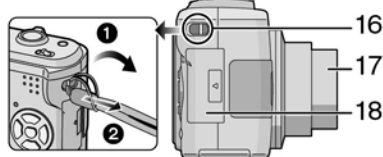

- 16 Strap eyelet
- 17 Lens barrel
- 18 Card door

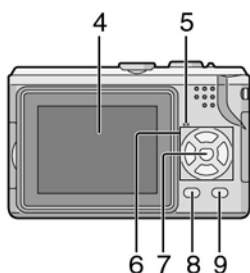

- 4 LCD monitor
- 5 Status indicator
- 6 Cursor buttons
 - ◀/Self-timer button
 - ▼/[REV] button
 - ▶/Flash setting button
 - ▲/Exposure compensation /Auto bracket/White balance fine adjustment /Backlight compensation in simple mode button
- 7 [MENU/SET] button
- 8 [DISPLAY]/[HIGH ANGLE] button
- 9 Delete/Single or burst mode button

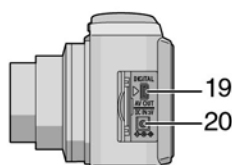

- 19 [DIGITAL/AV OUT] socket (DMC-LZ5)
[DIGITAL/V.OUT] socket (DMC-LZ4/DMC-LZ3)
- 20 [DC IN] socket
 - Always use a genuine Panasonic AC adaptor (DMW-AC6; optional).

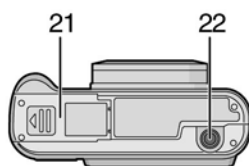

- 21 Battery door
- 22 Tripod receptacle
 - When you use a tripod, make sure it is stable when the camera is attached to it.

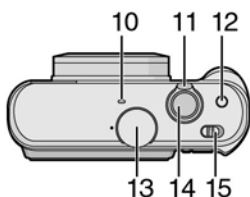

- 10 Microphone (DMC-LZ5)
- 11 Zoom lever
- 12 Optical image stabilizer button
- 13 Mode dial
- 14 Shutter button
- 15 Camera ON/OFF switch

About The Mode Dial

Adjust part (A) to the desired mode. The mode dial can be rotated 360°. Rotate it slowly and surely to adjust to each mode. (Do not adjust it to parts where there is no mode.)

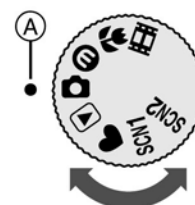

📷 : Normal picture mode
Use this mode for normal recording.

Ⓜ : Economy mode
This mode allows you to take pictures while reducing battery power consumption.

🌸 : Macro mode
This mode allows you to take a close-up picture of a subject.

🎥 : Motion picture mode
This mode allows you to record motion pictures.

SCN1 : Scene mode 1
SCN2 : Scene mode 2
This mode allows you to match the picture to the scene being recorded. Two frequently used scenes can be set to the mode dials [SCN1] and [SCN2].

♥ : Simple mode
This mode is recommended for beginners.

▶ : Playback mode
This mode allows you to play back recorded pictures.

6 Service Mode

6.1. Error Code Memory Function

1. General description

This unit is equipped with history of error code memory function, and can be memorized 32 error codes in sequence from the latest. When the error is occurred more than 32, the oldest error is overwritten in sequence.

The error code is not memorized when the power supply is shut down forcibly (when the unit is powered on by the battery, the battery is pulled out) because the error code is memorized to FLASH ROM when the unit is powered off.

2. How to display

The error code can be displayed by the following procedure:

Before perform the error code memory function, connect the AC adaptor or insert the battery, and insert the SD card.

• 1. The temporary cancellation of factory setting:

Set the mode dial to “ [Normal picture mode] (Red camera mark)”.

While keep pressing [Optical Image Stabilizer Button] and “[UP] of Cross key” simultaneously, turn the Power on.

• 2. The display of error code:

Press [Optical Image Stabilizer Button], [MENU] and “[LEFT] of Cross key” simultaneously with the step 1 condition.

The display is changed as shown below when the above buttons is pressed simultaneously.

Normal display → Error code display → Operation history display → Normal display →

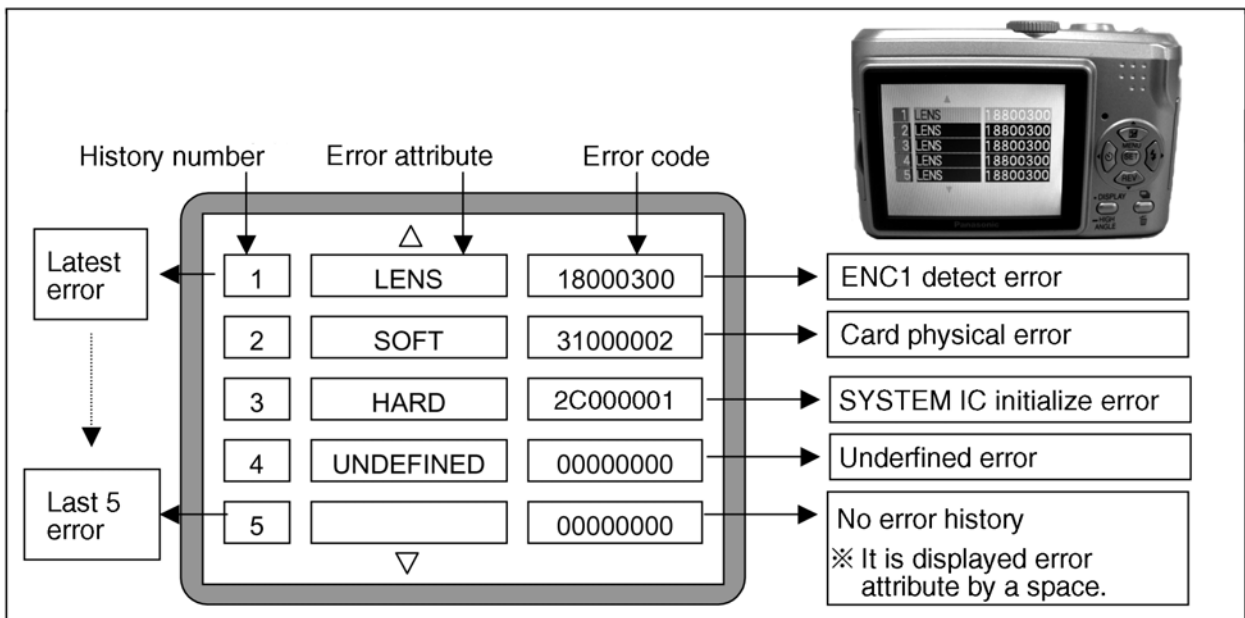

Example of Error Code Display

• 3. The change of display:

The error code can be memorized 32 error codes in sequence, however it is displayed 5 errors on the LCD.

Display can be changed by the following procedure:

“[UP] or [DOWN] of Cross key” : It can be scroll up or down one.

“[LEFT] or [RIGHT] of Cross key” : It can be display last 5 error or another 5 error.

• 4. How to read the error code:

One error code is displayed for 8 bit, the contents of error codes is indicated the table as shown below.

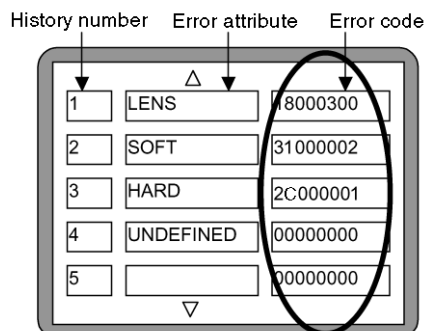

Attribute	Main item	Sub item	Error code		Contents (Upper)		
			High 4 bits	Low 4 bits	Check point (Lower)		
LENS	Lens drive	OIS	1800	1000	PSD (X) error. Hall element (X axis) position detect error in OIS unit. OIS Unit		
				2000	PSD (Y) error. Hall element (Y axis) position detect error in OIS unit. OIS Unit		
				3000	GYRO (X) error. Gyro (IC7102: X axis) detect error on Main P.C.B.. IC7102 (Gyro element) or IC6001 (VENUS PLUS)		
				4000	GYRO (Y) error. Gyro (IC7101: Y axis) detect error on Main P.C.B.. IC7101 (Gyro element) or IC6001 (VENUS PLUS)		
				5000	MREF error (Reference voltage error). IC7002 (LENS drive) or IC6001 (VENUS PLUS)		
				6000	Drive voltage (X) error. VENUS PLUS AD value error, LENS Unit, LENS flex breaks etc.		
				7000	Drive voltage (Y) error. VENUS PLUS AD value error, LENS Unit, LENS flex breaks etc.		
			C.B./Zoom	0100	HP Low detect error (C.B. encoder (full retract) always Low detect). FP9001-(2, 10) signal line or IC6001 (VENUS PLUS)		
				0200	HP High detect error (C.B. encoder (full retract) always High detect). FP9001-(2, 10) signal line or IC6001 (VENUS PLUS)		
				0300	ENC1 detect error (C.B. motor encoder detect error). FP9001-(2) signal line or IC6001 (VENUS PLUS)		
				0400	ENC2 detect error (C.B. motor encoder detect error). FP9001-(10) signal line or IC6001 (VENUS PLUS)		
				Zoom	0010	HP Low detect error (Zoom encoder always Low detect error).	
					0020	HP High detect error (Zoom encoder always High detect error).	
			0030		ENC1 detect error (Zoom encoder detect error).		
		0040	ENC2 detect error (Zoom encoder detect error).				
		Focus	0001	HP Low detect error (Focus encoder always Low detect error). FP9001-(27) signal line or IC6001 (VENUS PLUS)			
			0002	HP High detect error (Focus encoder always High detect error). FP9001-(27) signal line or IC6001 (VENUS PLUS)			
		Lens	1801	0000	Power ON time out error. Lens drive system		
				1802	0000	Power OFF time out error. Lens drive system	
		Adj.History	OIS	1900	2000	OIS adj. Yaw direction amplitude error (small)	
					3000	OIS adj. Pitch direction amplitude error (small)	
					4000	OIS adj. Yaw direction amplitude error (large)	
					5000	OIS adj. Pitch direction amplitude error (large)	
					6000	OIS adj. MREF error	
					7000	OIS adj. time out error	
					8000	OIS adj. Yaw direction off set error	
					9000	OIS adj. Pitch direction off set error	
	A000				OIS adj. Yaw direction gain error		
	B000				OIS adj. Pitch direction gain error		
	C000				OIS adj. Yaw direction position sensor error		
	D000				OIS adj. Pitch direction position sensor error		
E000	OIS adj. other error						
HARD	FLASH ROM (EEPROM Area)				FLASH ROM (EEPROM Area)	2B00	0001
		0002	EEPROM write error IC6002 (FLASH ROM)				
		SYSTEM	RTC	2C00		0001	SYSTEM IC initialize error Communication between IC6001 (VENUS PLUS) and IC9101 (SYSTEM)

Attribute	Main item	Sub item	Error code		Contents (Upper)
			High 4 bits	Low 4 bits	Check point (Lower)
SOFT	CPU	Reset	3000	0001	NMI reset
				0007	Non Mask-able Interrupt (30000001-30000007 are caused by factors)
	Card	Card	3100	0001	Card logic error SD card data line or IC6001 (VENUS PLUS)
				0002	Card physical error SD card data line or IC6001 (VENUS PLUS)
				0004	Write error SD card data line or IC6001 (VENUS PLUS)
				0005	Format error
	CPU, ASIC hard	Stop	3800	0001	Camera task finish process time out. Communication between Lens system and IC6001 (VENUS PLUS)
				0002	Camera task invalid code error. IC6001 (VENUS PLUS)
				0100	File time out error in recording motion image IC6001 (VENUS PLUS)
				0200	File data send error in recording motion image IC6001 (VENUS PLUS)
	Operation	Power on	3B00	0000	FLASHROM processing early period of camera during movement.
	Zoom	Zoom	3C00	0000	I do not complete zoom lens processing Zoom lens
					3500
			3501	0000	Though record preprocessing is necessary, it is not called.
			3502	0000	Though record preprocessing is necessary, it is not completed.

• **5. How to returned to Normal Display:**

Turn the power off and on, to exit from Error code display mode.

NOTE:

The error code can not be initialized.

6.2. Confirmation of Firmware Version

The Firmware version can be confirmed by ordering the following steps:

- **Step 1. The temporary cancellation of factory setting:**

Set the mode dial to “[Normal picture mode] (Red camera mark)”.

Insert the SD memory card which has a few photo data.

While keep pressing [Optical Image Stabilizer] and “[UP] of Cross key” simultaneously, then turn the power on.

- **Step 2. Confirm the version:**

Set the mode dial to “[Playback]” and then press [DISPLAY] to switch to LCD with indication. (Fig. A)

Press [Optical Image Stabilizer] and “[DOWN] of Cross key” simultaneously. (No need to keep pressing.)

(The version information is displayed on the LCD with green colour letters.) (Fig. B)

CAUTION:

The version information does not display if the LCD has switched to LCD with indication already.

In this case, press [DISPLAY] to switch to LCD with indication.

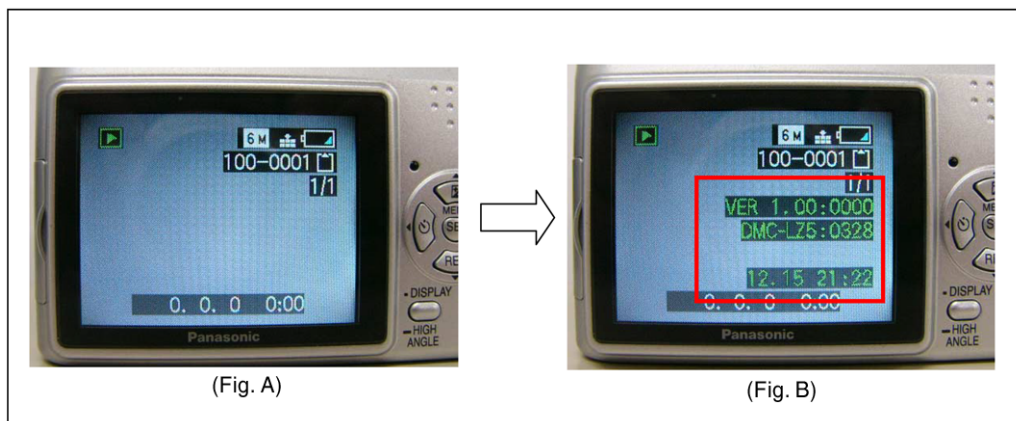
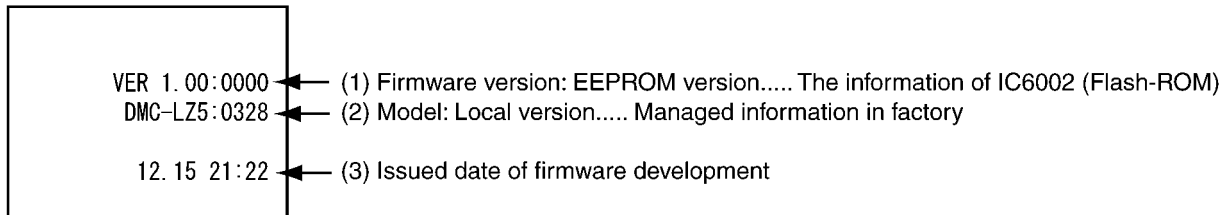







<Point>

- The firmware version and EEPROM version can be confirmed with the information (1).
- The information (2), (3) are just reference.

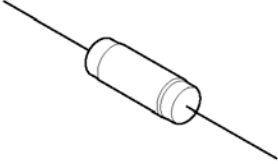
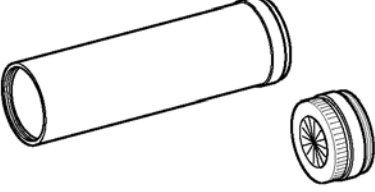
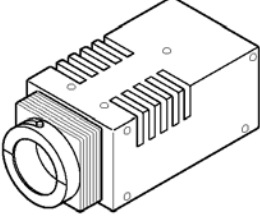
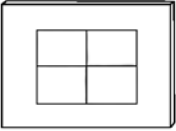
7 Service Fixture & Tools

7.1. Service Fixture and Tools

The following Service Fixture and tools are used for checking and servicing this unit.

Resistor for Discharging ERG5SJ102	Infinity Lens (with Focus Chart) VFK1164TCM02	LIGHT BOX VFK1164TDVLB
 An equivalent type of Resistor may be used.		 ※ with DC Cable
TR Chart VFK1975	Lens Cleaning Kit (BK) VFK1900BK	Grease (for lens) VFK1829
	 * Only supplied as 10 set/box.	
Furoyl grease (for focus motor) VFK1850	T3 Trox Driver RFKZ0334	ND Filter ND0.1 Type VFK1164ND01
		 An equivalent type of Filter may be used.

7.2. When Replacing the Main PCB

After replacing the MAIN PCB, be sure to achieve adjustment.

The adjustment instruction is available at "software download" on the "Support Information from NWBG/VDBG-PAVC" web-site in "TSN system", together with Maintenance software.

7.3. Service Position

This Service Position is used for checking and replacing parts. Use the following Extension cables for servicing.

Table S1 Extension Cable List

No.	Parts No.	Connection	Form
1	VFK1951	FP9001 (MAIN) - MASTER FLANGE UNIT	39PIN 0.3 FFC
2	VFK1978	FP9002 (MAIN) - CCD UNIT	31PIN 0.3 FFC
3	VFK1950	FP9003 (MAIN) - LCD UNIT	33PIN 0.3 FFC
4	VFK1974	FP9004 (MAIN) - LCD UNIT	4PIN 0.5 FFC
5	VFK1870	PP9001 (MAIN) - PS8001 (FLASH TOP)	30PIN B to B

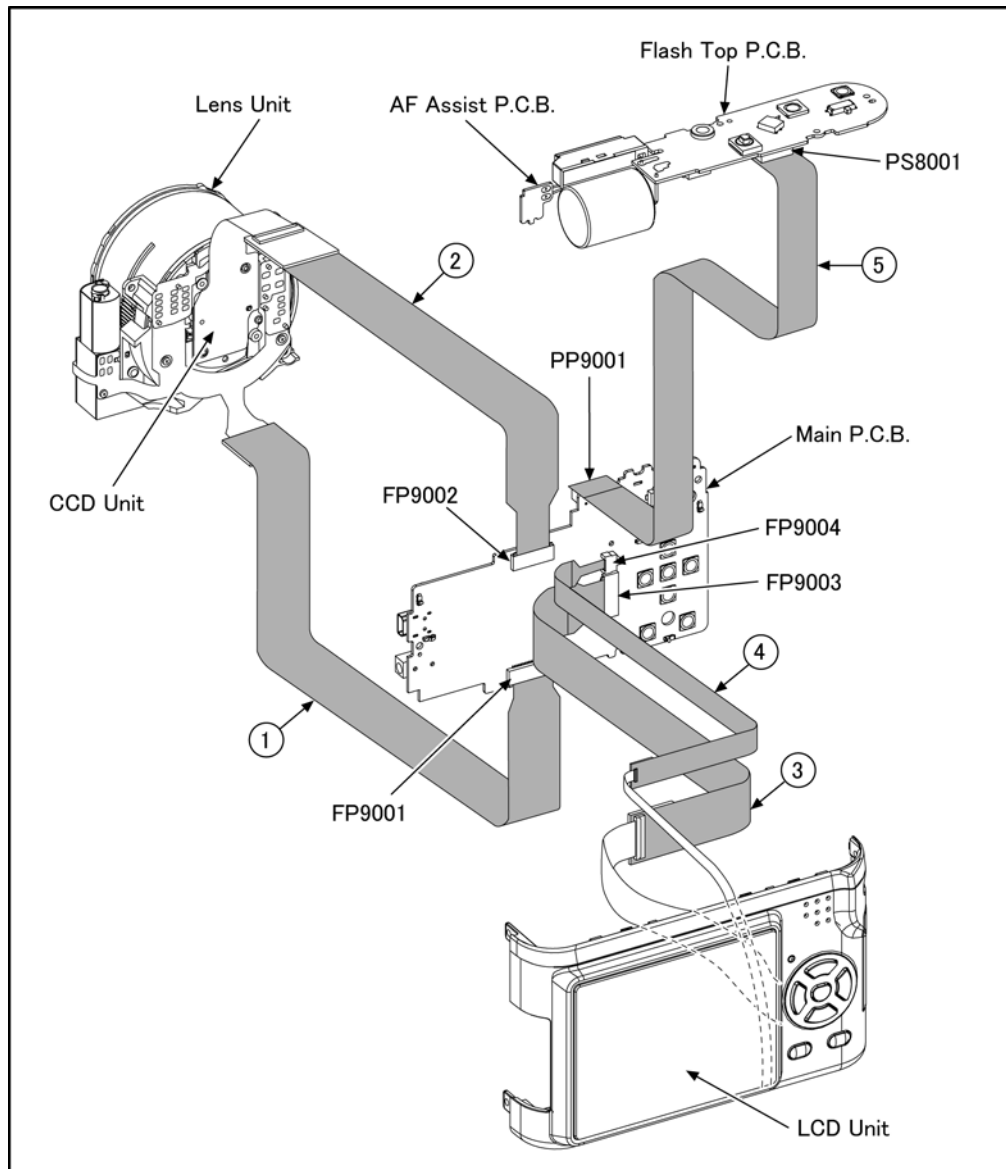

CAUTION-1. (When servicing FLASH TOP PCB)

1. Be sure to discharge the capacitor on FLASH TOP PCB.

Refer to "How to Discharge the Capacitor on Flash top PCB".

The capacitor voltage is not lowered soon even if the AC Cord is unplugged or the battery is removed.

2. Be careful of the high voltage circuit on FLASH TOP PCB.
3. DO NOT allow other parts to touch the high voltage circuit on FLASH TOP PCB.

8 Disassembly and Assembly Instructions

8.1. Disassembly Flow Chart

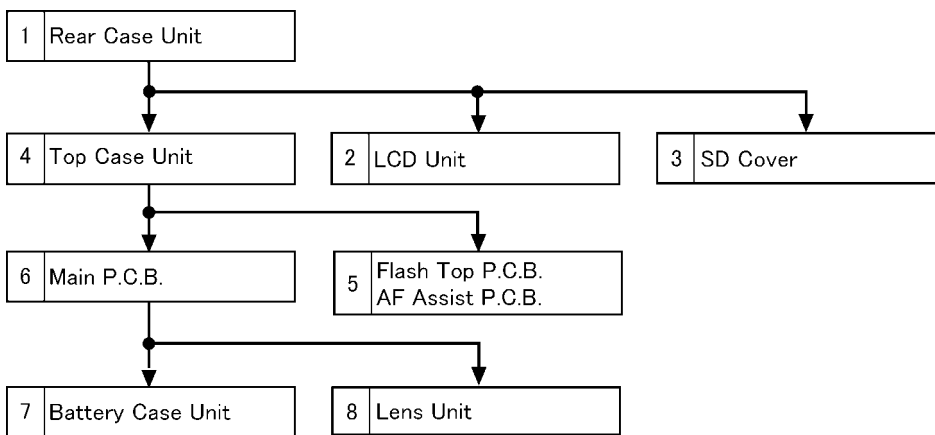

8.2. PCB Location

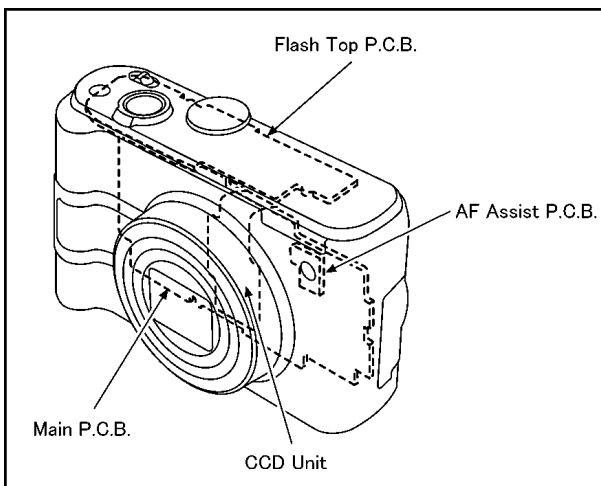

8.3. Disassembly Procedure

8.3.1. Removal of the Rear Case Unit

No.	Item	Fig	Removal
1	Rear Case Unit	Fig. D1	Card
			Battery
			6 Screws (A)
			FP9003(Flex)
			FP9004(Flex)
			3 Locking tabs
			Rear Case Unit
		Fig. D2	About the connector
2	LCD Unit	Fig. D3	1 Screw (B)
			LCD Holder
			LCD Unit
3	SD Cover	Fig. D4	SD Earth Plate
			SD Cover
4	Top Case Unit	Fig. D5	1 Screw (C)
			PP9001(Connector)
			Top Case Unit
5	Flash Top PCB AF Assist PCB	Fig. D6	3 Screws (D)
			3 Locking tabs
			Flash Cover
			Flash Top PCB
			AF Assist PCB
6	Main PCB	Fig. D8	3 Screws (E)
			FP9001(Flex)
			FP9002(Flex)
			Main PCB
		Fig. D9	About the connector
7	Battery Case Unit	Fig. D10	2 Solders
			Battery Case Unit
8	Lens Unit	Fig. D11	3 Screws (F)
			Lens Unit

NOTE:

When servicing and reassembling, remove the card and battery from the unit.

- Card
- Battery
- Screw (A) × 6
- FP9003(Flex)
- FP9004(Flex)
- Locking tab × 3

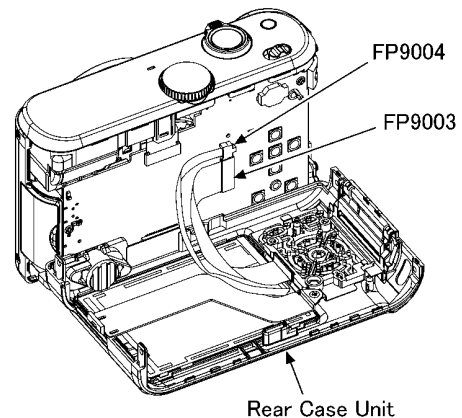
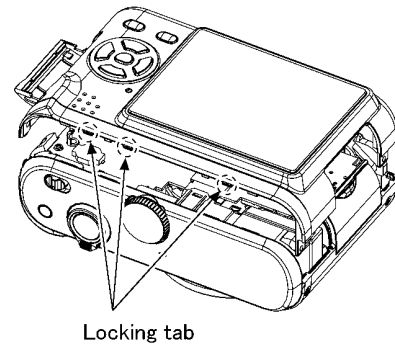
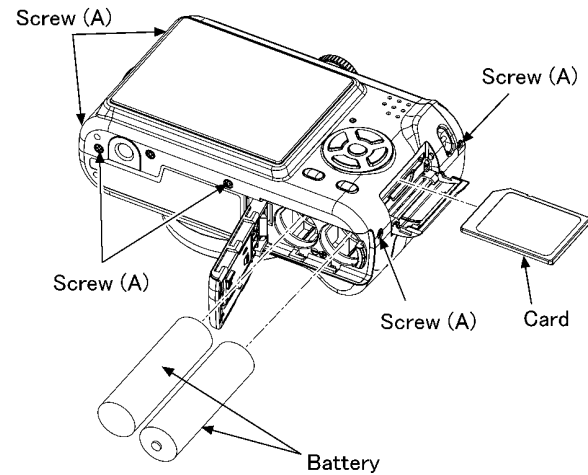

Screw (A)

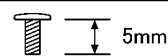

SILVER

CAUTION

Take care to handle the connector (FP9003, FP9004) because it is easy to be damaged. (Refer to "About the connector (FP9003, FP9004)".)

Fig. D1

About the connector (FP9003, FP9004)

1. Lift the center of cover in the indicated by arrow.

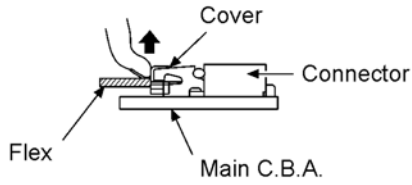

2. Release the lock of cover, and then pull out the flex.

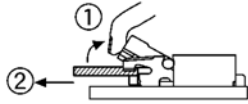

※ It is released the lock to turn the cover until an angle of 40.

NOTE: Do not push the cover over an angle of 135. It is full opened condition. (Refer to the figure as shown below.)

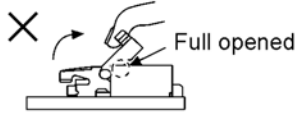

Fig. D2

8.3.2. Removal of the LCD Unit

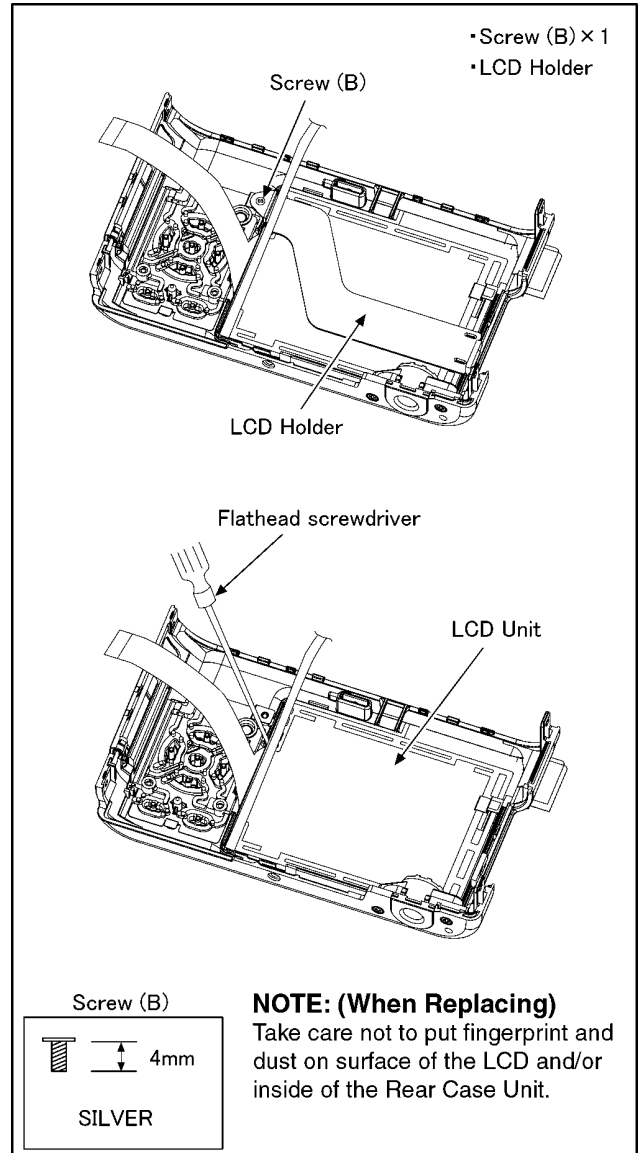

Fig. D3

8.3.3. Removal of the SD Cover

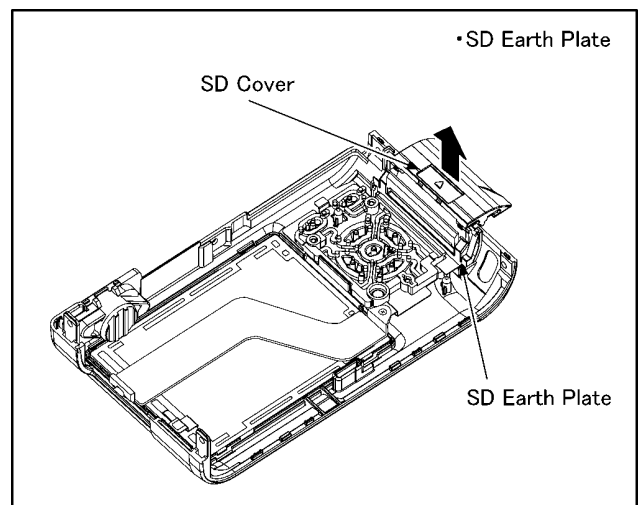

Fig. D4

8.3.4. Removal of the Top Case Unit

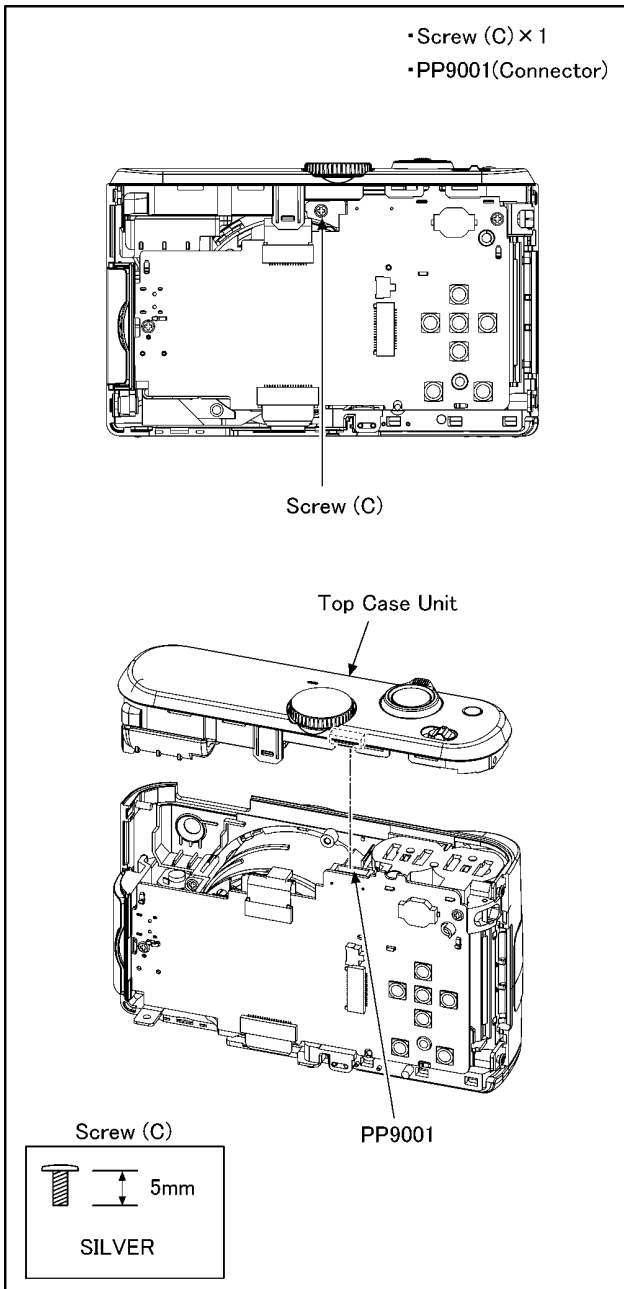

Fig. D5

8.3.5. Removal of the Flash Top PCB and AF Assist PCB

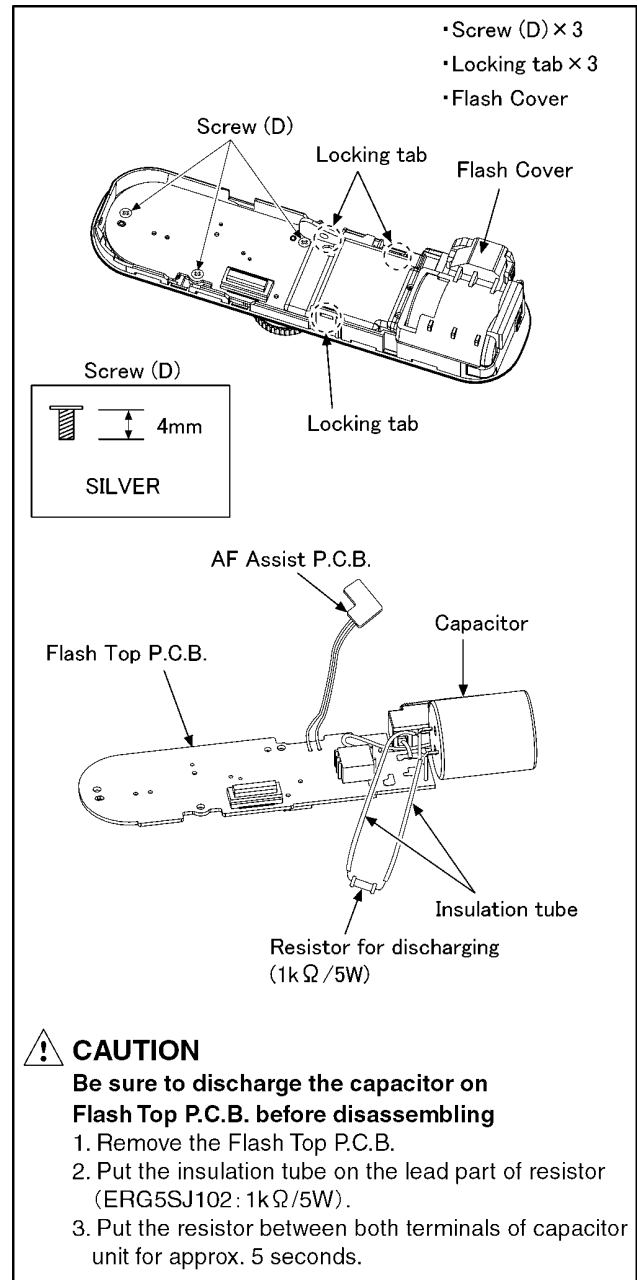

Fig. D6

NOTE: (When Installing)

Align the convex of power switch and groove of power knob.
Align the convex of mode dial switch and groove of mode dial.

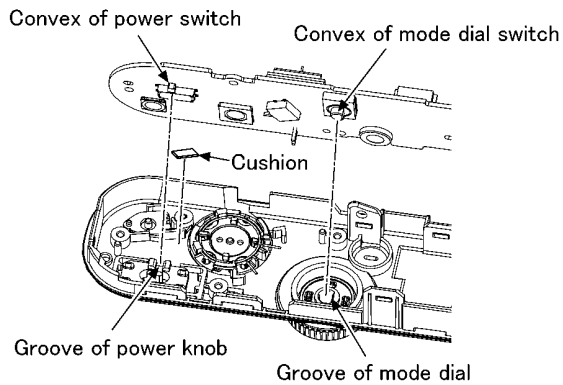

Fig. D7

8.3.6. Removal of the Main PCB

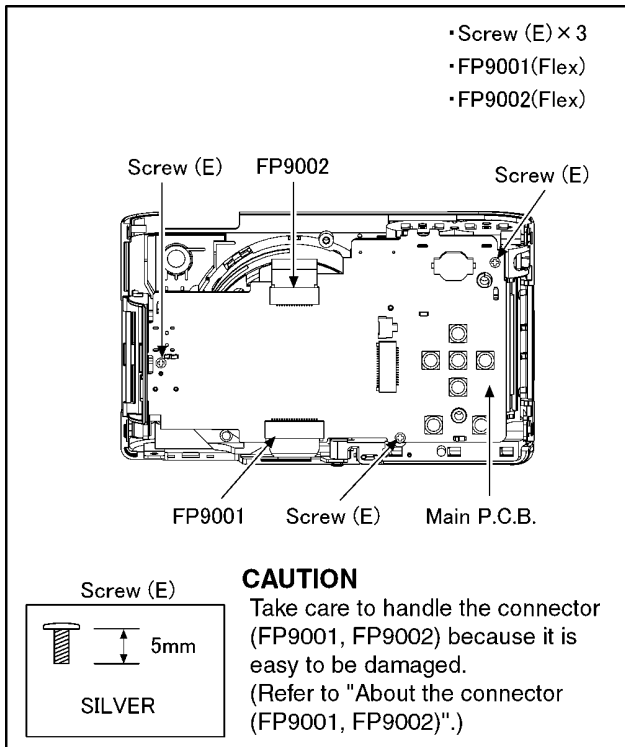
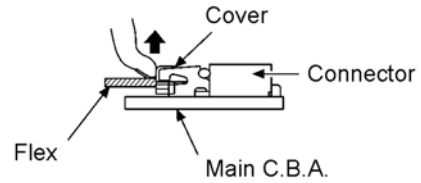

Fig. D8

About the connector (FP9001, FP9002)

1. Lift the center of cover in the indicated by arrow.



2. Release the lock of cover, and then pull out the flex.

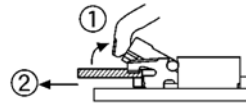

※ It is released the lock to turn the cover until an angle of 40.

NOTE: Do not push the cover over an angle of 135. It is full opened condition. (Refer to the figure as shown below.)



Fig. D9

8.3.7. Removal of the Battery Case Unit

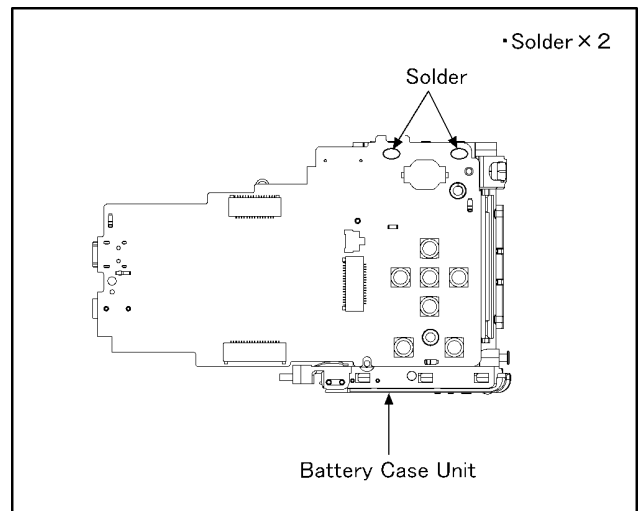

Fig. D10

8.3.8. Removal of the Lens Unit

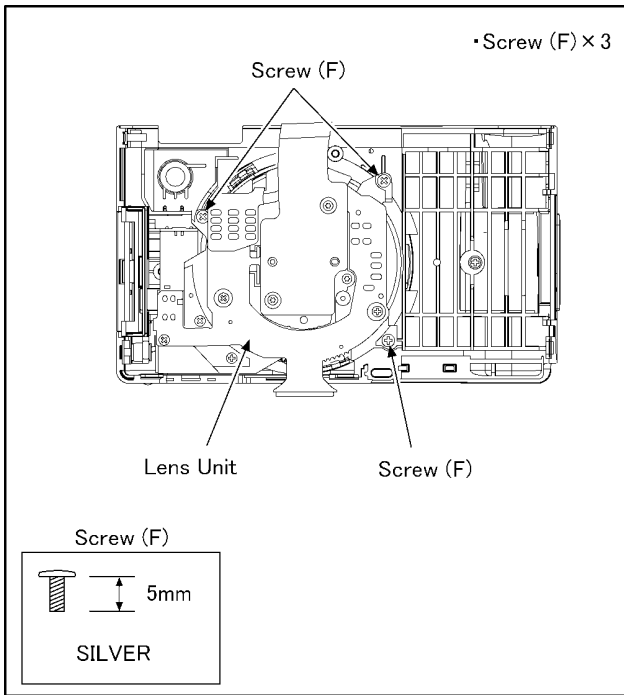

Fig. D11

NOTE: (When Assembling)

Be sure to confirm the following points when assembling.

- The Screw is tightened enough.
- Assembling conditions are fine. (No distortion, no illegal-space.)
- No dust and/or dirt on every Lens surfaces.
- LCD image is fine. (No dust and dirt on it, and no gradient images.)

8.4. Disassembly Procedure for the Lens

NOTE: When Disassembling and Assembling for the Lens

1. To minimize the possibility of the CCD being dirt, perform disassemble and/or assemble under the condition of the CCD is being mounted.
2. Take care that the dust and dirt are not entered into the lens.
In case of the dust is putted on the lens, blow off them by airbrush.
3. Do not touch the surface of lens.
4. Use lens cleaning KIT (BK)(VFK1900BK).

8.4.1. Removal of the Direct Frame/Drive Frame/1st Lens Frame/2nd Lens Frame Unit

1. Unscrew the 2 screws (A).
2. Remove the Zoom Motor Unit to the lock (A) (2 points).
3. Loosen the 3 screws (B) (1 turn).

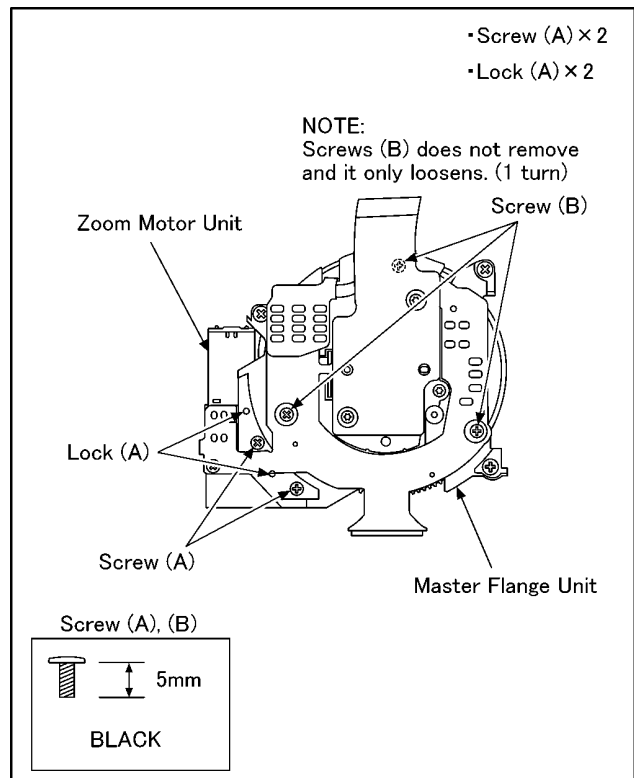

4. Remove the 3 cam caps.

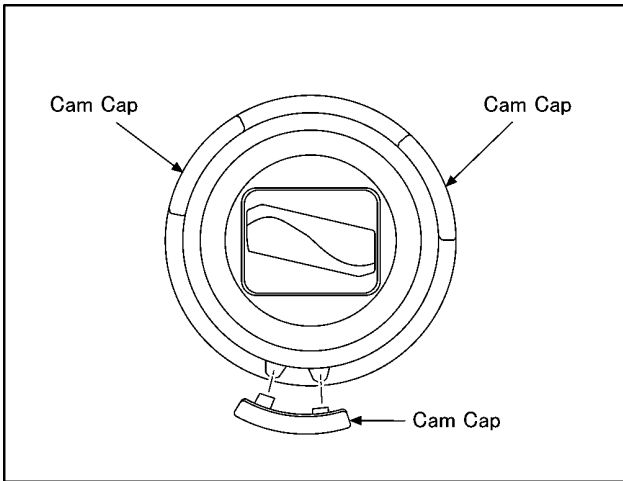

5. Pull down the plate part of master flange unit (refer to arrow(1)), and then turn the master flange unit to counterclockwise fully (refer to arrow(2)).

6. Remove the direct frame/drive frame/1st lens frame/2nd lens frame unit to the indicated by arrow.

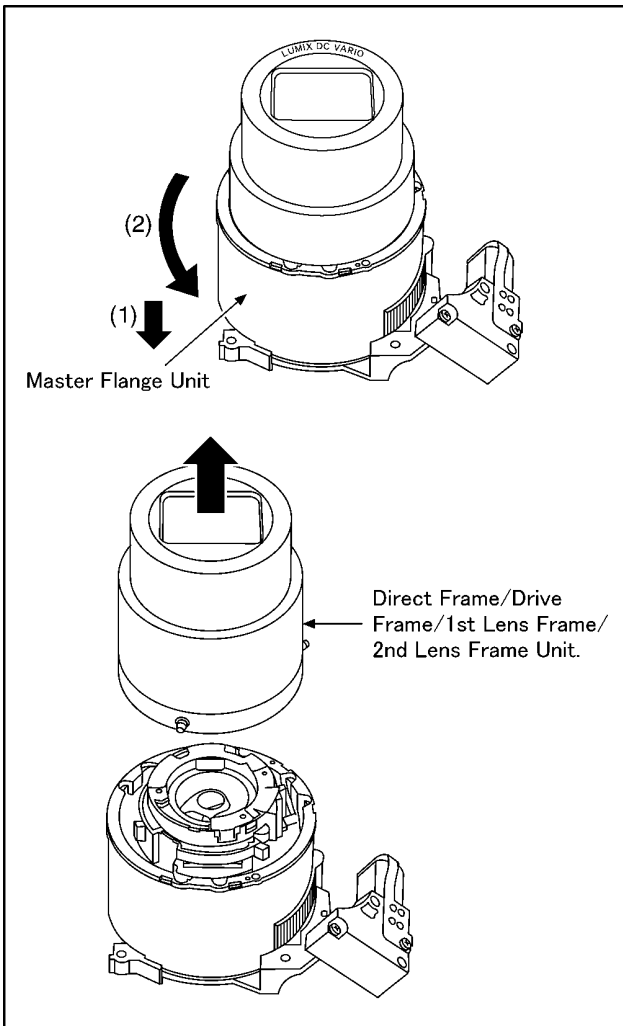

8.4.2. Removal of the Direct Frame Unit

1. Turn the drive frame unit to the indicated by arrow. (Retracting direction)

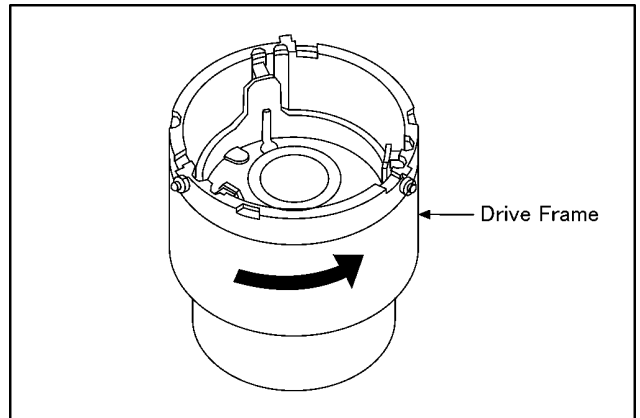

2. Remove the direct frame/1st lens frame/2nd lens frame unit from drive frame to the indicated by arrow.

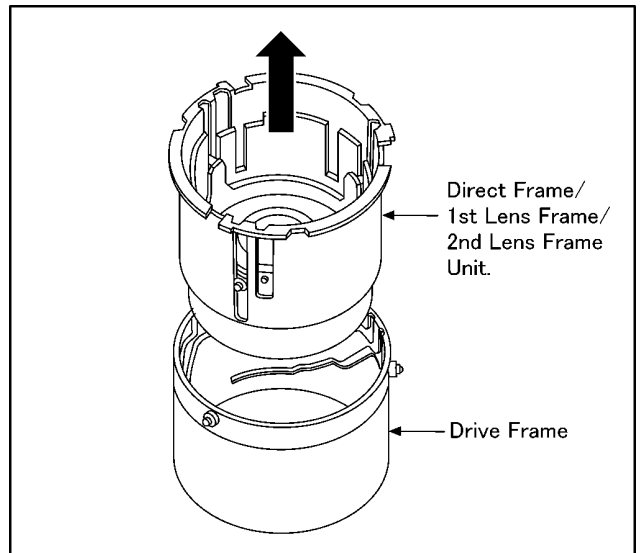

3. Push the 1st lens frame/2nd lens frame unit from lens front side, and then remove the 1st lens frame/2nd lens frame unit from direct frame.

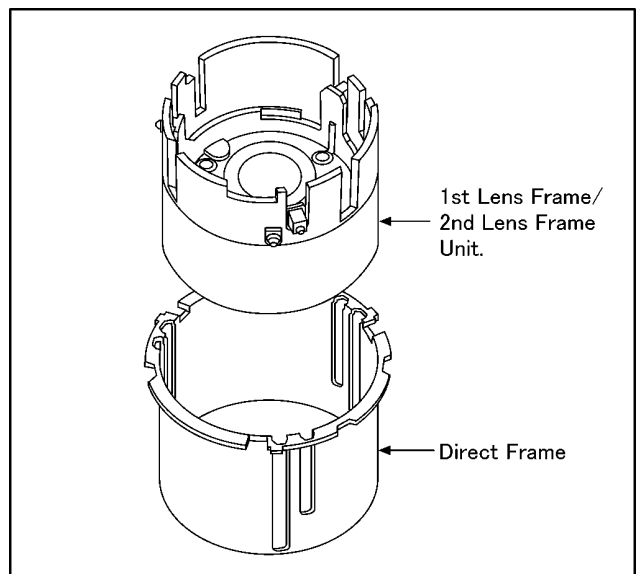

8.5. Assembly Procedure for the Lens

8.5.1. Phase alignment of the Direct Frame and Drive Frame Unit

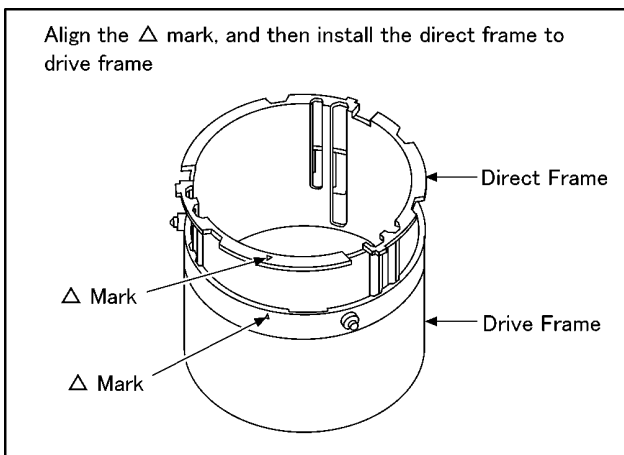

8.5.2. Phase alignment of the Direct/Drive Frame Unit and 1st Lens Frame/2nd Lens Frame Unit

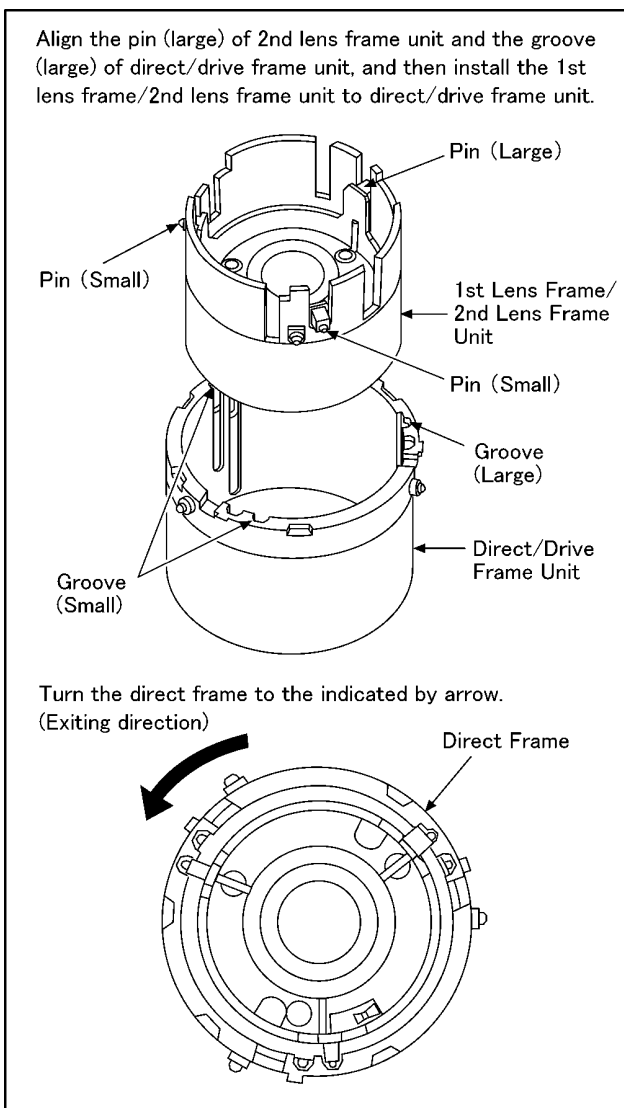

8.5.3. Phase alignment of the 1st Lens Frame/2nd Lens Frame/ Drive Frame/ Direct Frame Unit and Master Flange Unit

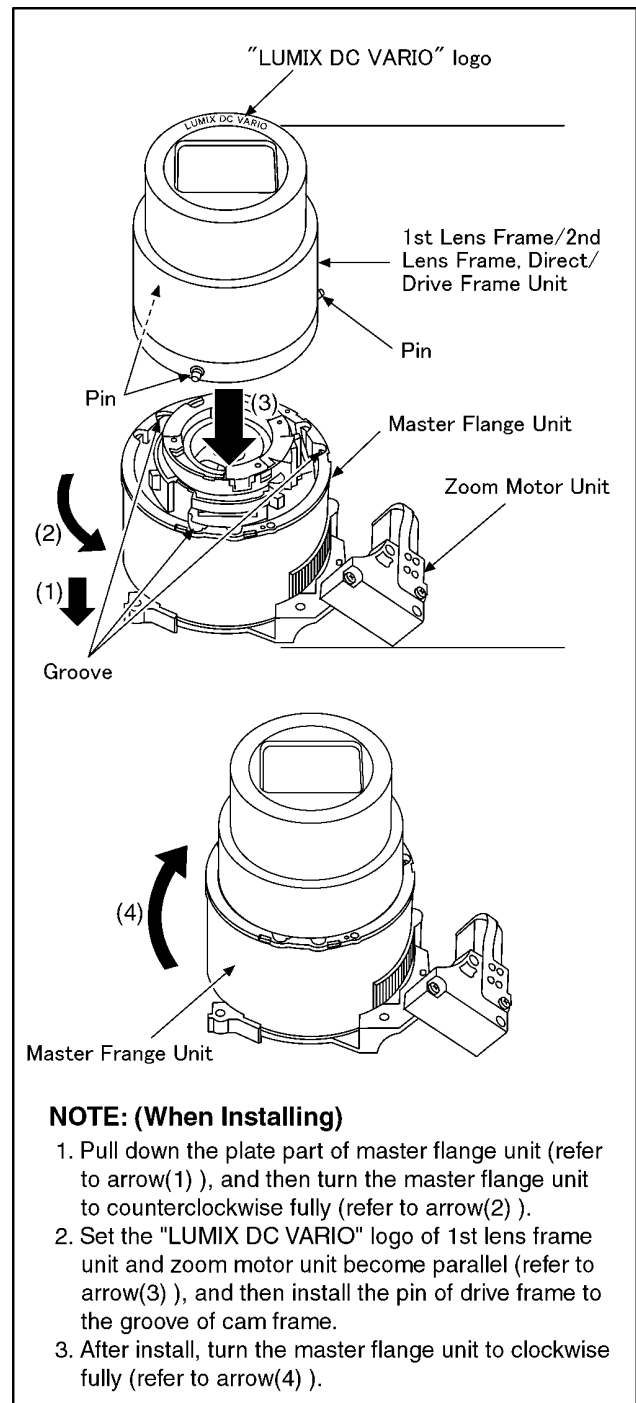

8.5.4. Assembly for the Zoom Motor Unit

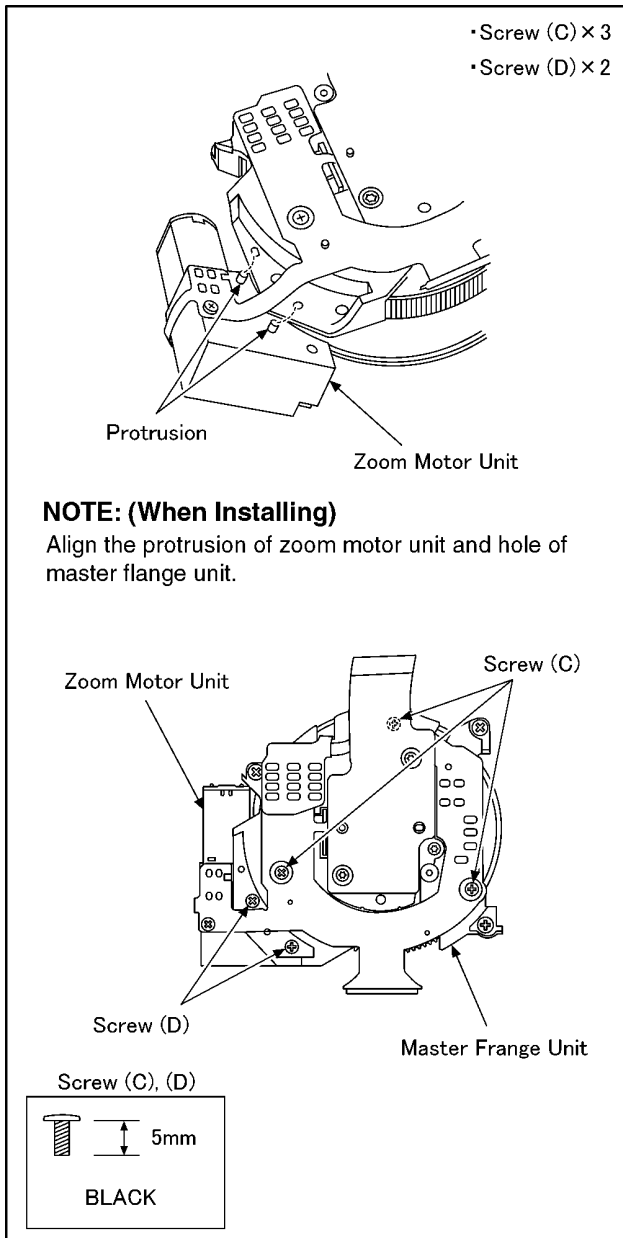

8.6. Removal of the CCD

To prevent the CCD unit from catching the dust and dirt, do not remove the CCD unit except for replacing.

- Trox driver (T3): RFKZ0334

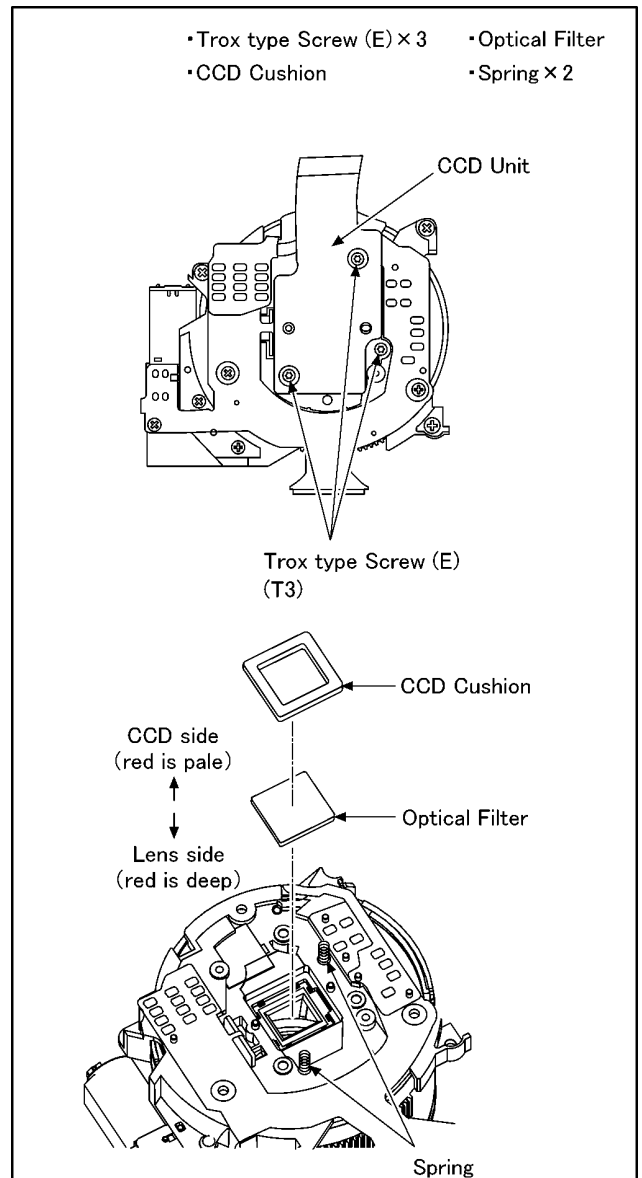

NOTE: (When Installing the CCD Unit)

Definitions of mount side of Optical filter.

*Set the optical filter under the condition of reflecting the fluorescent lamp can be seen by your eyes.

*Although depth of the red color may be changed in accordance with seeing angle, compare the deepest red color in both sides to define each side.

Lens side: red color is deeper than the other side.

CCD side: red color is paler than the other side.

It can be easy to confirm the red color density on the blue paper.

9 Measurements and Adjustments

9.1. Matrix Chart for Replaced Part and Necessary Adjustment

The relation between Replaced part and Necessary Adjustment is shown in the following table.

When concerned part is replaced, be sure to achieve the necessary adjustment(s).

As for Adjustment condition/procedure, consult the "Adjustment Manual" which is available in Adjustment software.

The Adjustment software is available at "TSN Website", therefore, access to "TSN Website" at "Support Information from NWBG/VDBG-PAVC".

NOTE:

After adjustments have been terminated, make sure to achieve "INITIAL SETTINGS".

Adjustment Item		Replaced Part				
		Main P.C.B.	VENUS (IC6001)	Flash-ROM (IC6002)	Lens Part (Excluding CCD)	CCD Unit
Camera Section	OIS hall element adjustment (OIS)	○	○	○	○	
	Back focus adjustment (BF)	○	○	○	○	
	Shutter adjustment (SHT)	○	○	○	○	○
	ISO sensitivity adjustment (ISO)	○	○	○	○	○
	AWB adjustment High brightness coloration inspection (WBL)	○	○	○	○	○
	CCD white scratch compensation (WKI)	○	○	○		○

NOTE:

*There is no LCD adjustment in this model.

*There is no CCD Black scratch compensation adjustment (BKI) in this model.

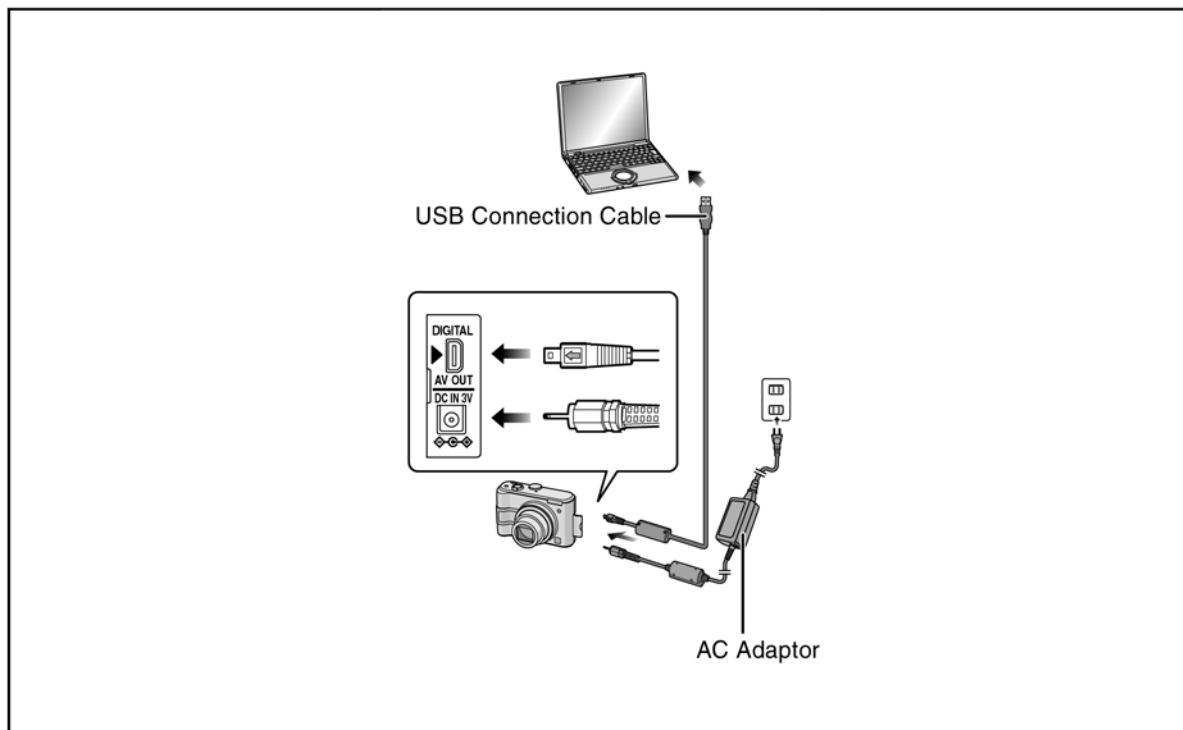

10 Maintenance

10.1. Cleaning Lens and LCD Panel

Do not touch the surface of lens and LCD Panel with your hand.

When cleaning the lens, use air-Blower to blow off the dust.

When cleaning the LCD Panel, dampen the lens cleaning paper with lens cleaner, and the gently wipe the their surface.

Note:

The Lens Cleaning KIT ; VFK1900BK(Only supplied as 10 set/Box) is available as Service Aid.

Service Manual

Diagrams and Replacement Parts List

Digital Camera

DMC-LZ3 SERIES

DMC-LZ4 SERIES

DMC-LZ5 SERIES

Vol. 1
Colour
(S).....Silver Type

S1. About Indication of The Schematic Diagram

S1.1. Important Safety Notice

COMPONENTS IDENTIFIED WITH THE MARK \triangle HAVE THE SPECIAL CHARACTERISTICS FOR SAFETY. WHEN REPLACING ANY OF THESE COMPONENTS USE ONLY THE SAME TYPE.

1. Although reference number of the parts is indicated on the P.C.B. drawing and/or schematic diagrams, it is NOT mounted on the P.C.B. when it is displayed with "\$" mark.
2. It is only the "Test Round" and no terminal (Pin) is available on the P.C.B. when the TP (Test Point) indicated as "●" mark.
3. The voltage being indicated on the schematic diagram is measured in "Standard-Playback" mode when there is no specify mode is mentioned.
4. Although the voltage and waveform available on here is measured with standard frame, it may be differ from actual measurement due to modification of circuit and so on.
5. The voltage being indicated here may be include observational-error (deviation) due to internal-resistance and/or reactance of equipment. Therefore, handle the value indicated on here as reference.

6. Use the parts number indicated on the Replacement Parts List .

7. Indication on Schematic diagrams:

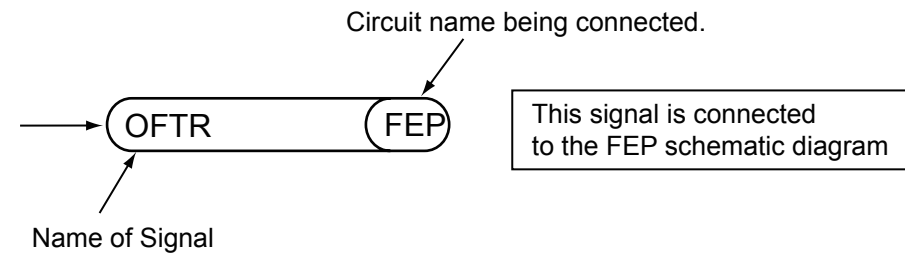

Table of contents

<p>S1. About Indication of The Schematic Diagram S-1</p> <p>S1.1. Important Safety Notice..... S-1</p> <p>S2. Voltage Chart S-2</p> <p>S2.1. Flash Top P.C.B..... S-2</p> <p>S3. Block Diagram..... S-3</p> <p>S3.1. Overall Block Diagram S-3</p> <p>S3.2. System Control Block Diagram S-4</p> <p>S3.3. Video/Audio Process Block Diagram S-5</p> <p>S3.4. Sensor Block Diagram S-6</p> <p>S3.5. Lens Drive Block Diagram..... S-7</p> <p>S3.6. Power Block Diagram..... S-8</p> <p>S4. Schematic Diagram..... S-9</p> <p>S4.1. Interconnection Diagram S-9</p> <p>S4.2. AF Assist Schematic Diagram S-10</p> <p>S4.3. Flash Top Schematic Diagram S-11</p> <p>S4.4. Lens Flex Schematic Diagram S-12</p> <p>S4.5. CCD Flex Schematic Diagram S-13</p>	<p>S5. Print Circuit Board S-14</p> <p>S5.1. AF Assist P.C.B. S-14</p> <p>S5.2. Flash Top P.C.B. S-14</p> <p>S5.3. Lens Flex P.C.B. S-15</p> <p>S5.4. CCD Flex P.C.B. S-16</p> <p>S6. Replacement Parts List S-17</p> <p>S7. Exploded View S-23</p> <p>S7.1. Frame and Casing Section (1) S-23</p> <p>S7.2. Frame and Casing Section (2) S-24</p> <p>S7.3. Packing Parts and Accessories Section..... S-25</p>
---	--

S2. Voltage Chart

Note) Indicated voltage values are the standard values for the unit measured by the DC electronic circuit tester (high-impedance) with the chassis taken as standard.
Therefore, there may exist some errors in the voltage values, depending on the internal impedance of the DC circuit tester.

S2.1. Flash Top P.C.B.

REF No.	PIN No.	REC
IC8001	1	0
IC8001	2	0
IC8001	3	4.9
IC8001	4	0
IC8001	5	0
Q8002	1	0
Q8002	2	0
Q8002	3	0
Q8002	4	0
Q8002	5	0
Q8002	6	0
Q8002	7	0
Q8002	8	0
Q8009	1	2.1
Q8009	2	2.1
Q8009	3	0
Q8009	4	0
Q8009	5	2.1
Q8009	6	2.1

S3. Block Diagram

S3.1. Overall Block Diagram

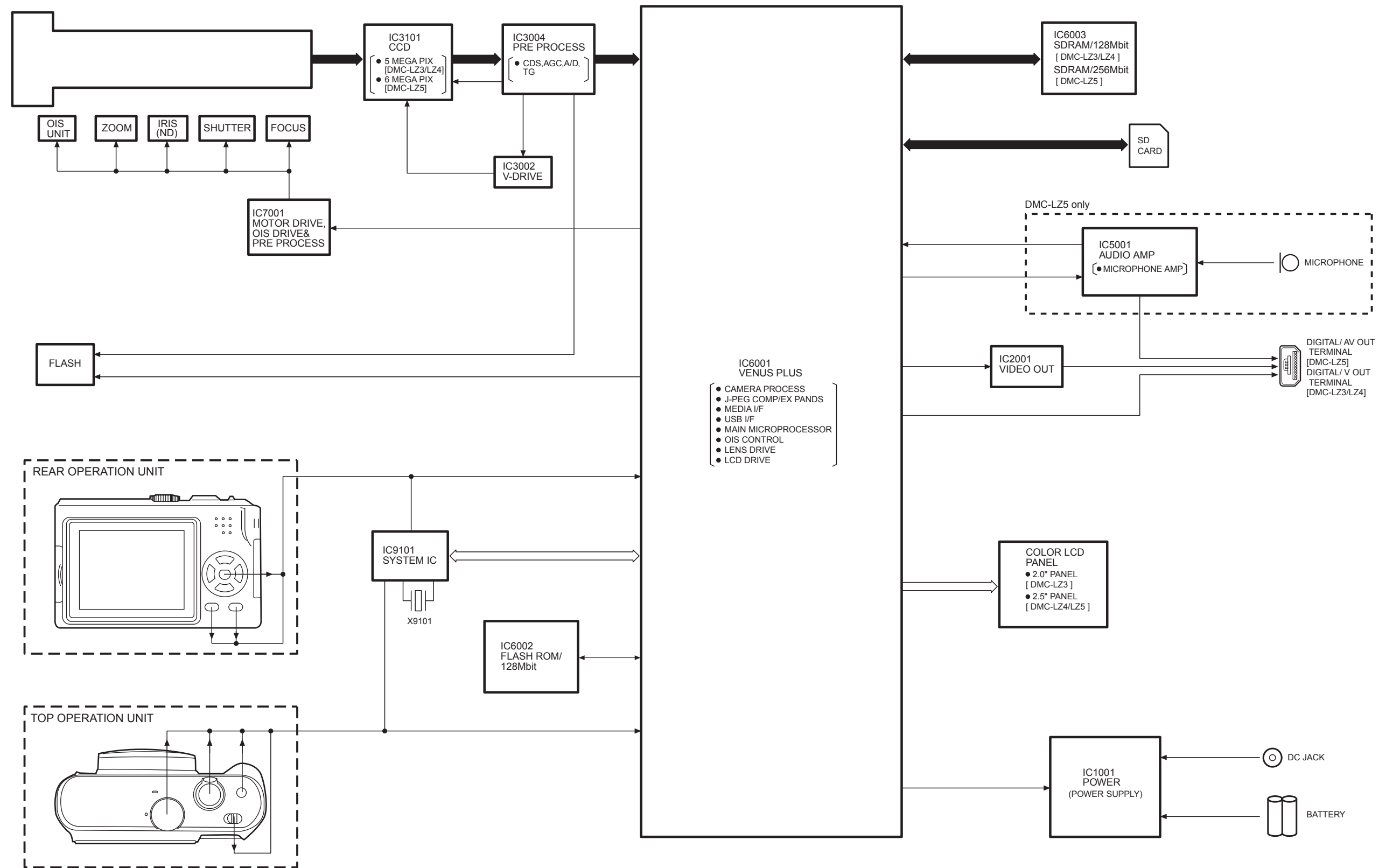

S3.2. System Control Block Diagram

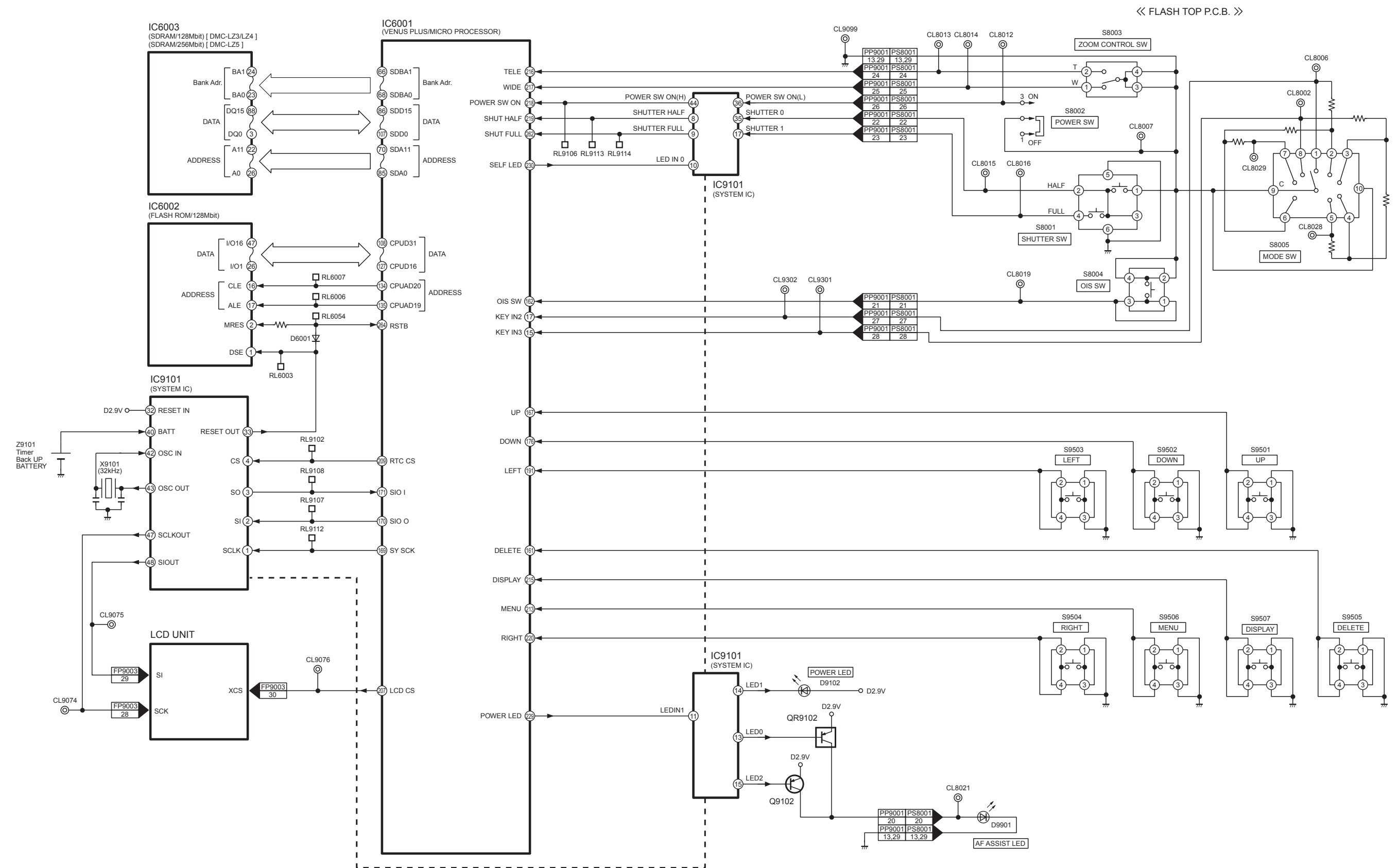

S3.3. Video/Audio Process Block Diagram

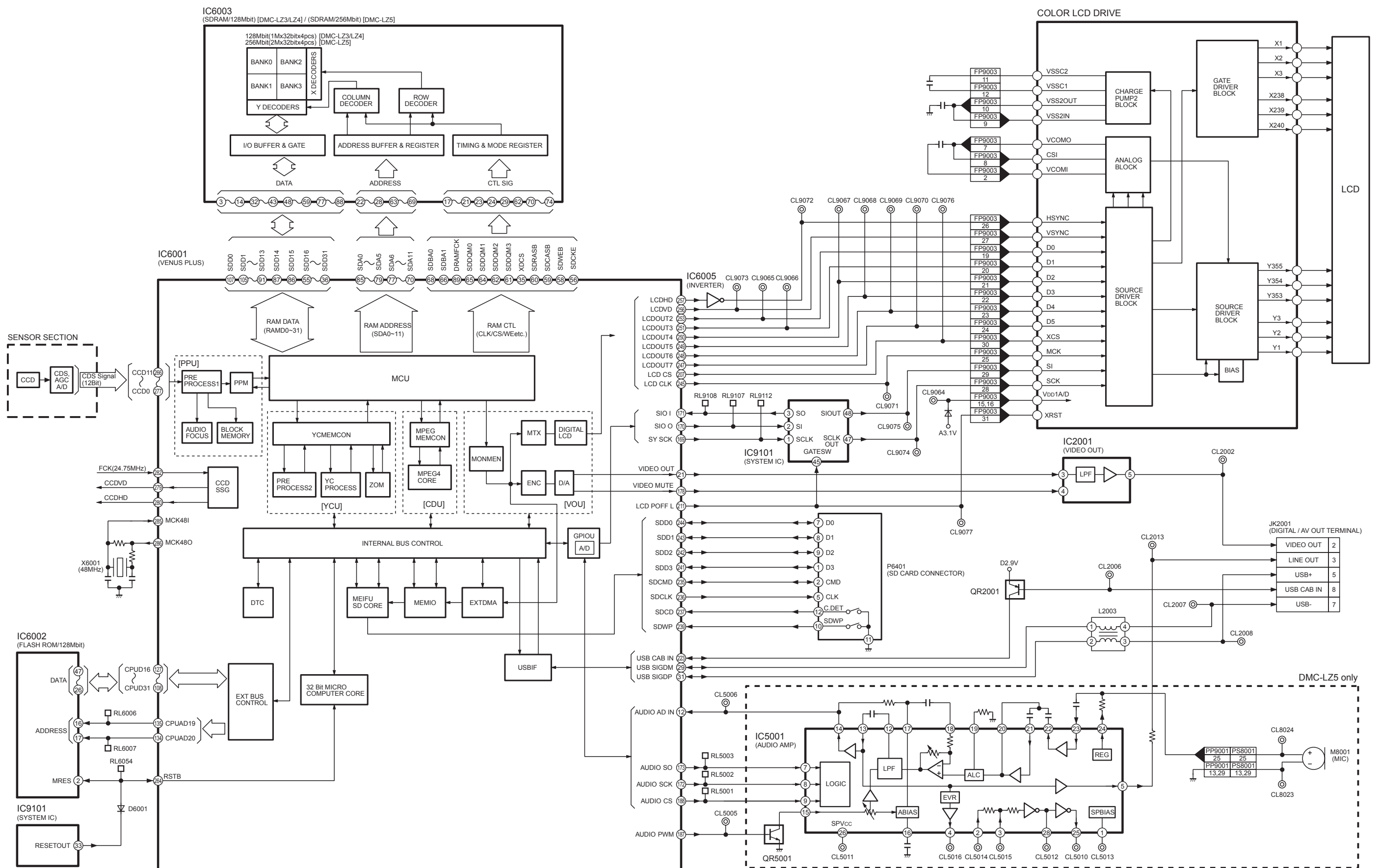

S3.4. Sensor Block Diagram

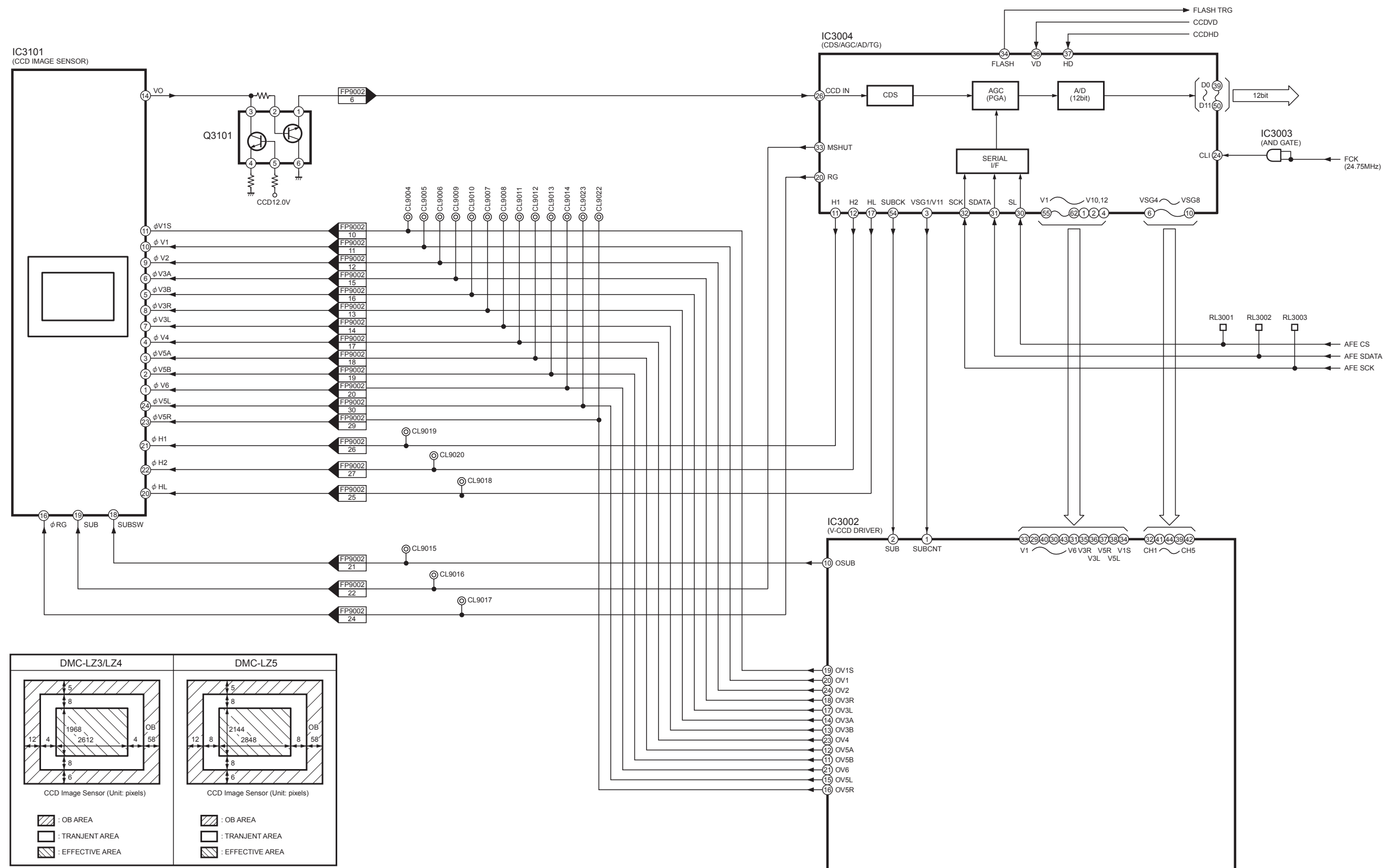

S3.5. Lens Drive Block Diagram

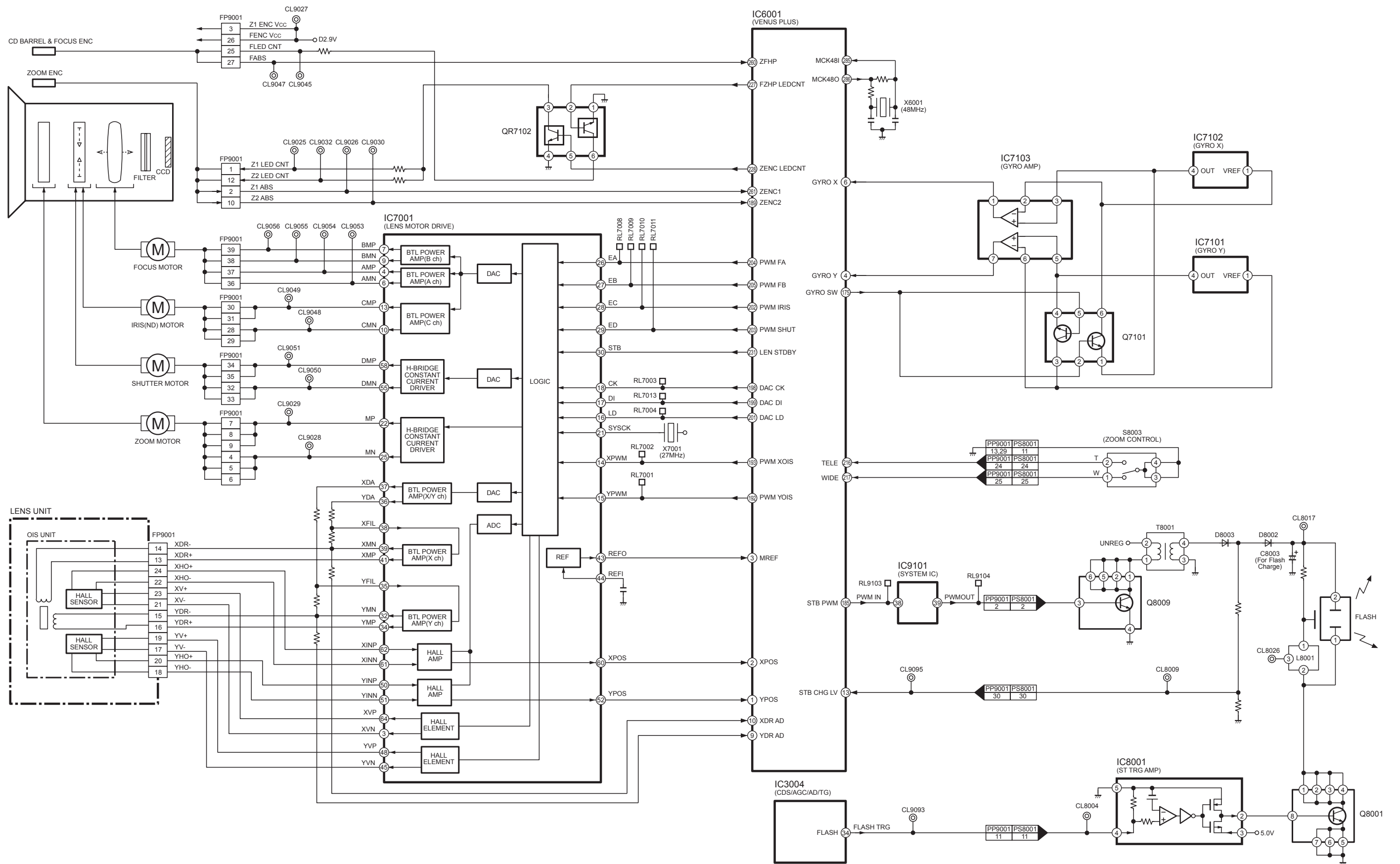

S3.6. Power Block Diagram

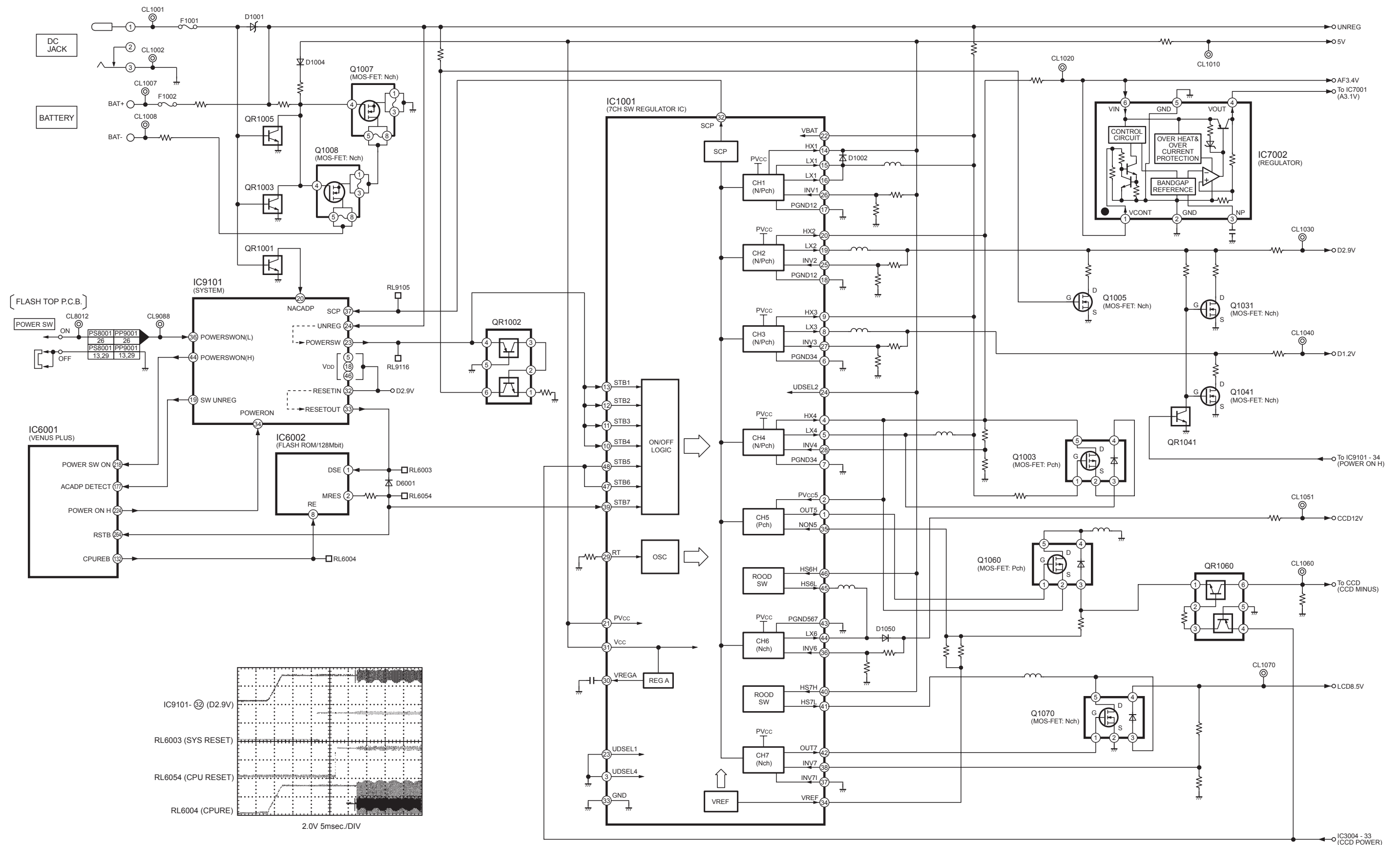

S4. Schematic Diagram

S4.1. Interconnection Diagram

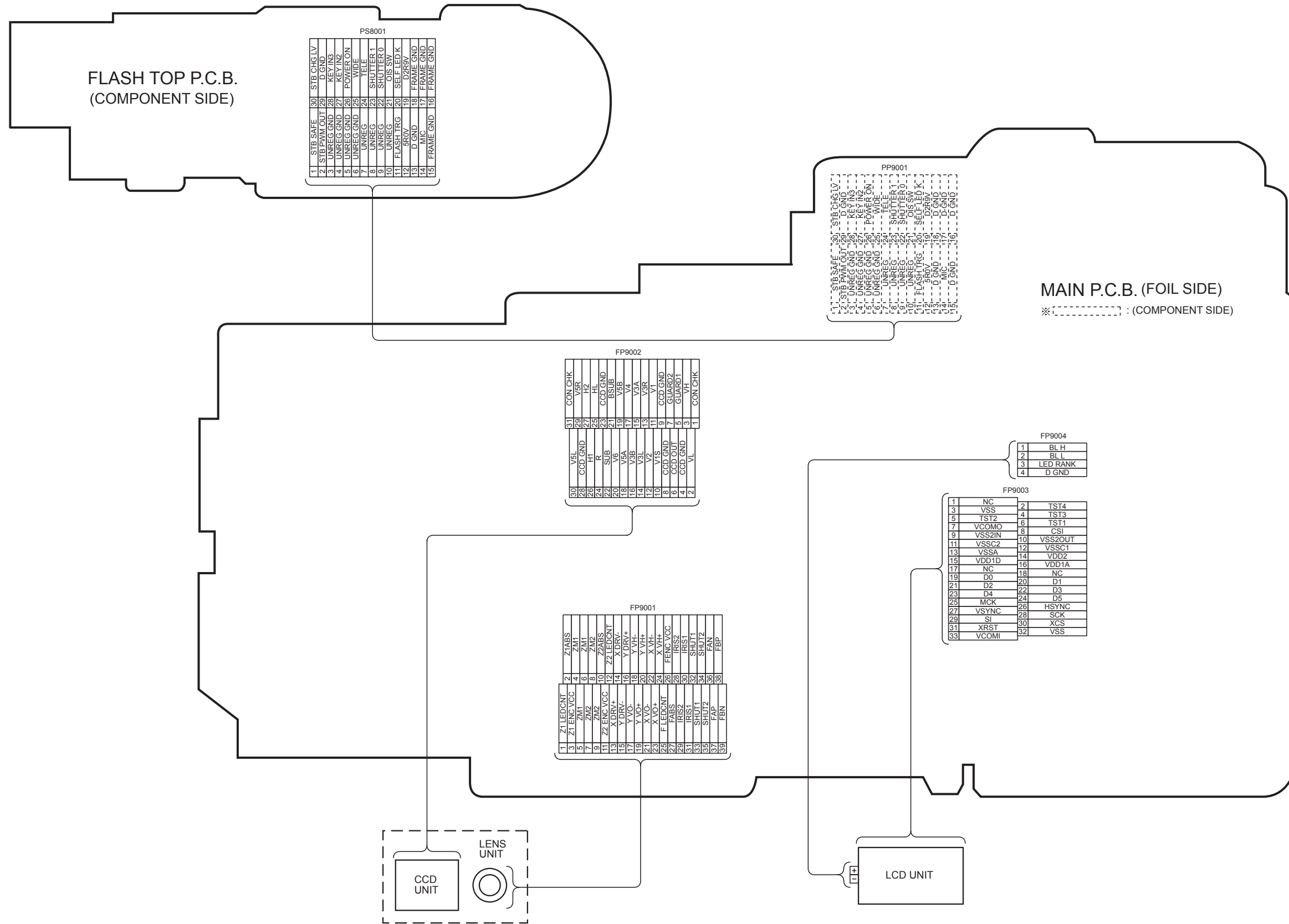

S4.2. AF Assist Schematic Diagram

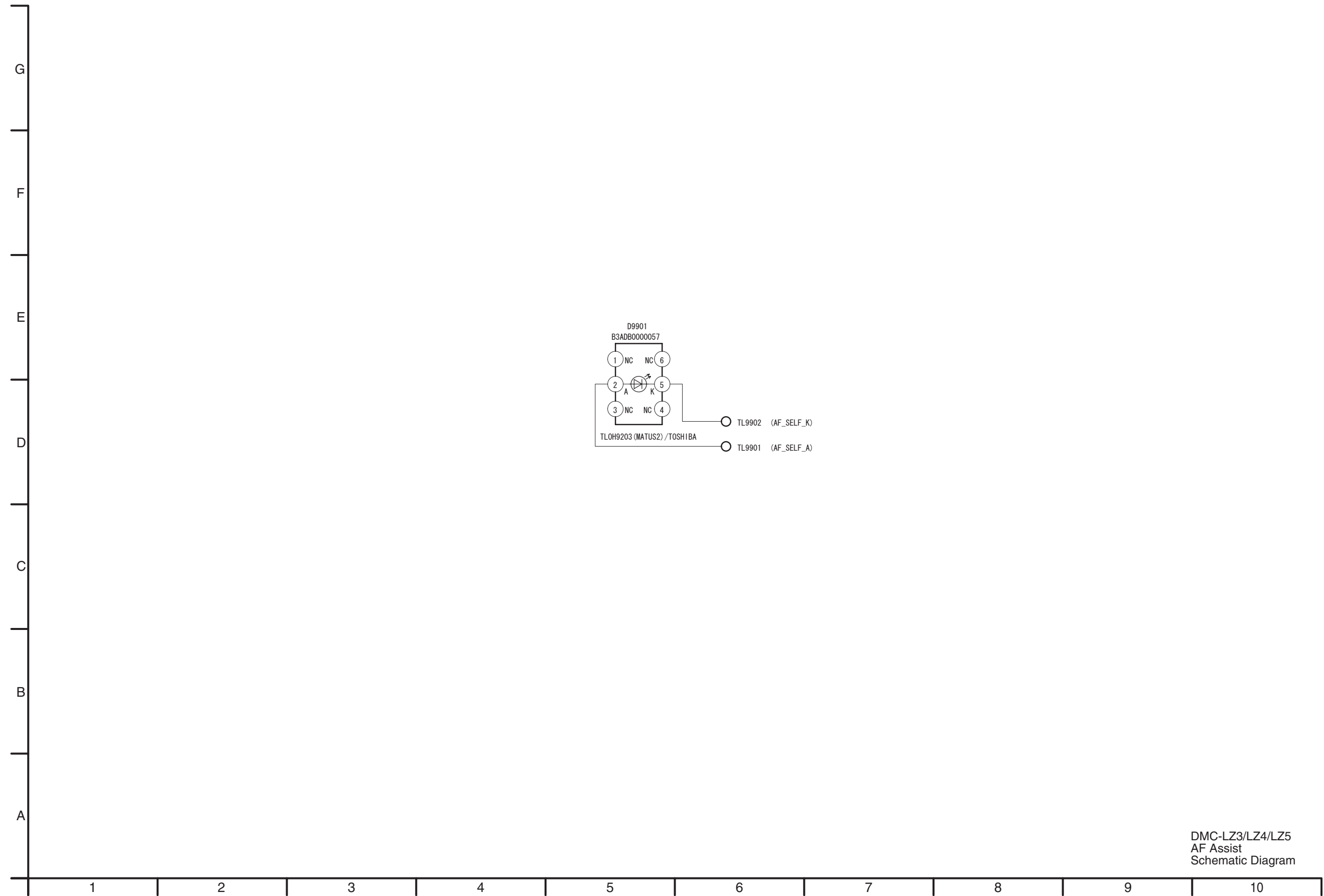

DMC-LZ3/LZ4/LZ5
AF Assist
Schematic Diagram

S4.3. Flash Top Schematic Diagram

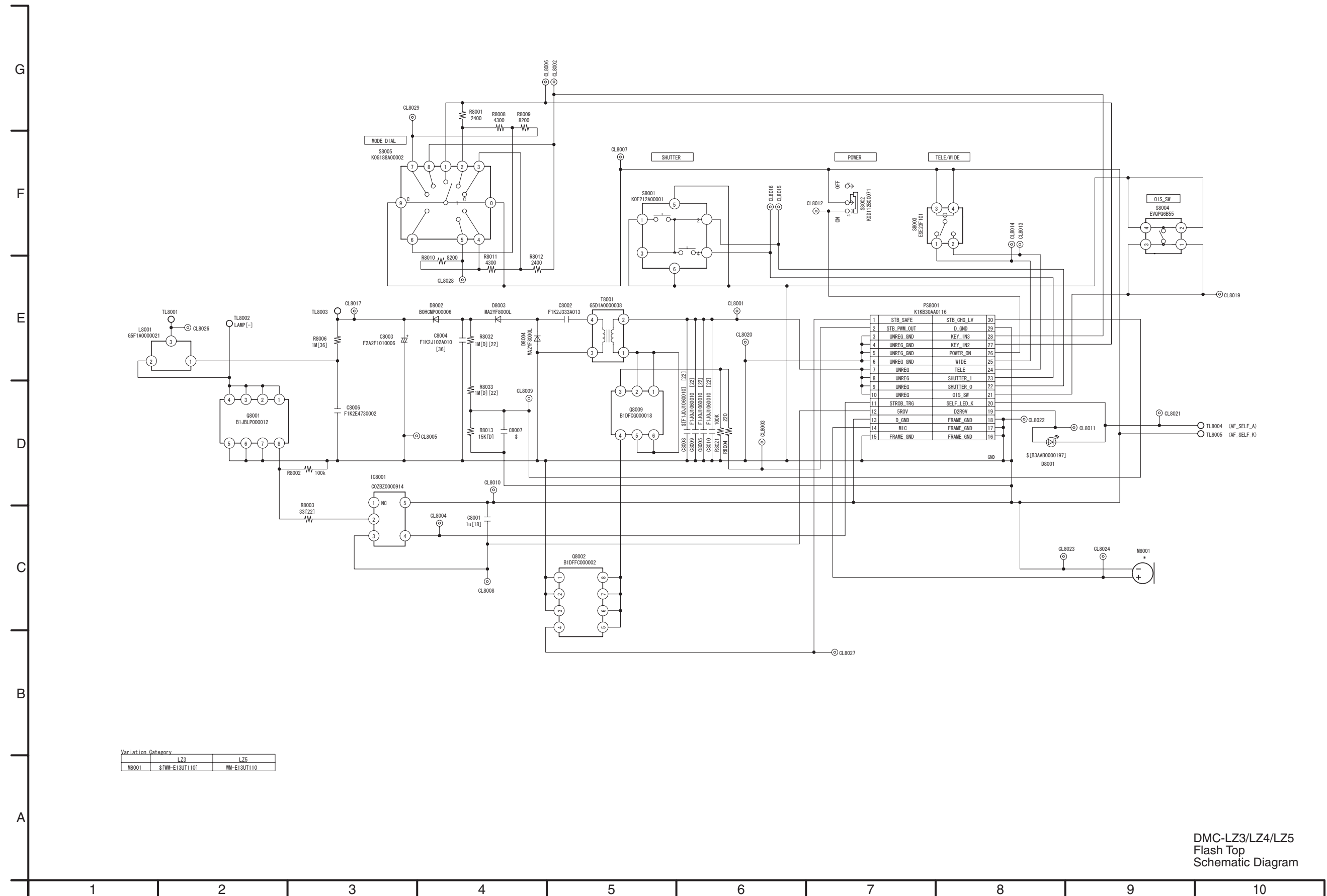

Variation Category

	LZ3	LZ5
M8001	\$TMM-E13UT110J	MM-E13UT110

DMC-LZ3/LZ4/LZ5
Flash Top
Schematic Diagram

S4.4. Lens Flex Schematic Diagram

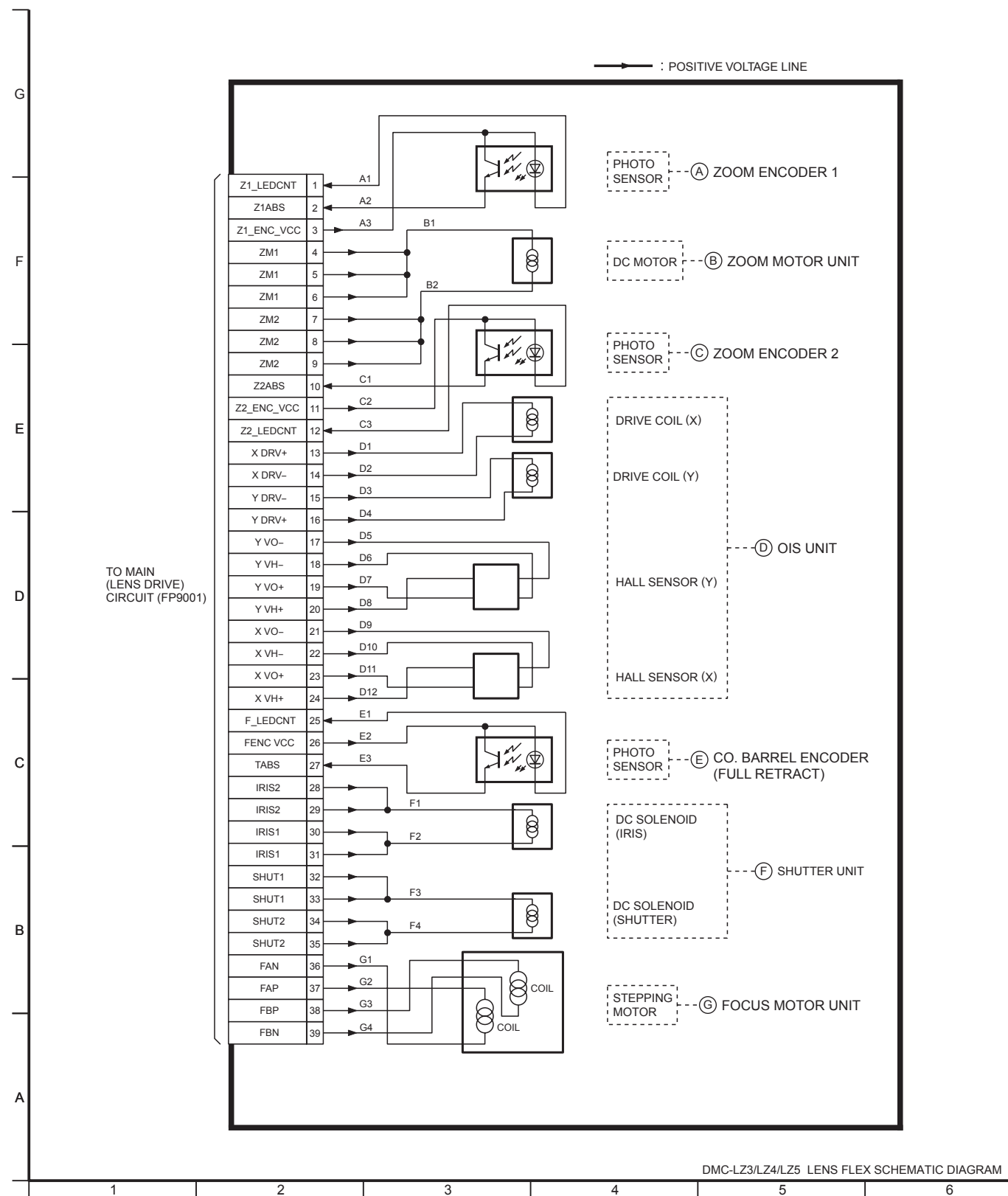

S4.5. CCD Flex Schematic Diagram

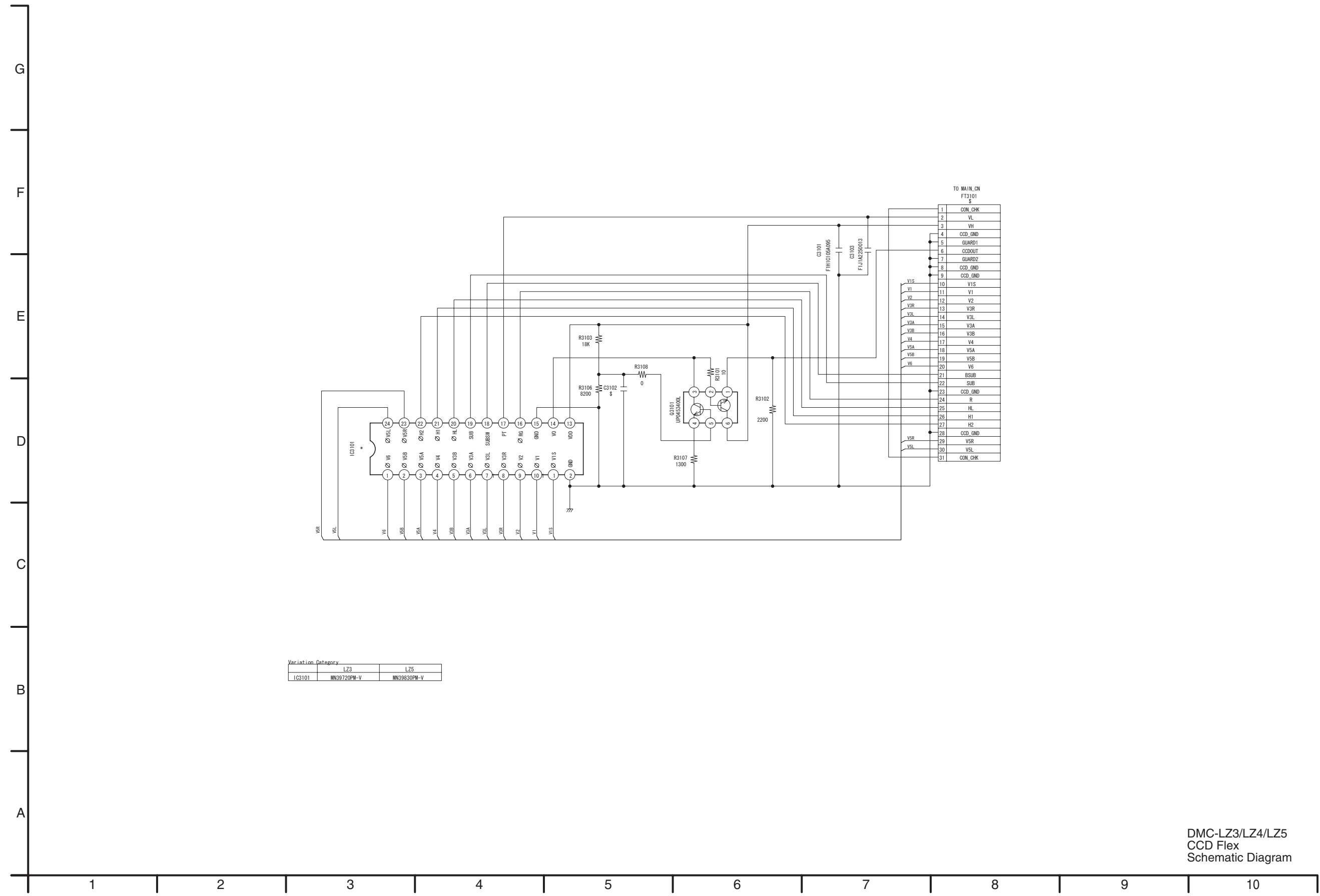

Variation Category		
	LZ3	LZ5
IC3101	MN39720PM-V	MN39830PM-V

DMC-LZ3/LZ4/LZ5
CCD Flex
Schematic Diagram

S5. Print Circuit Board

S5.1. AF Assist P.C.B. / S5.2. Flash Top P.C.B.

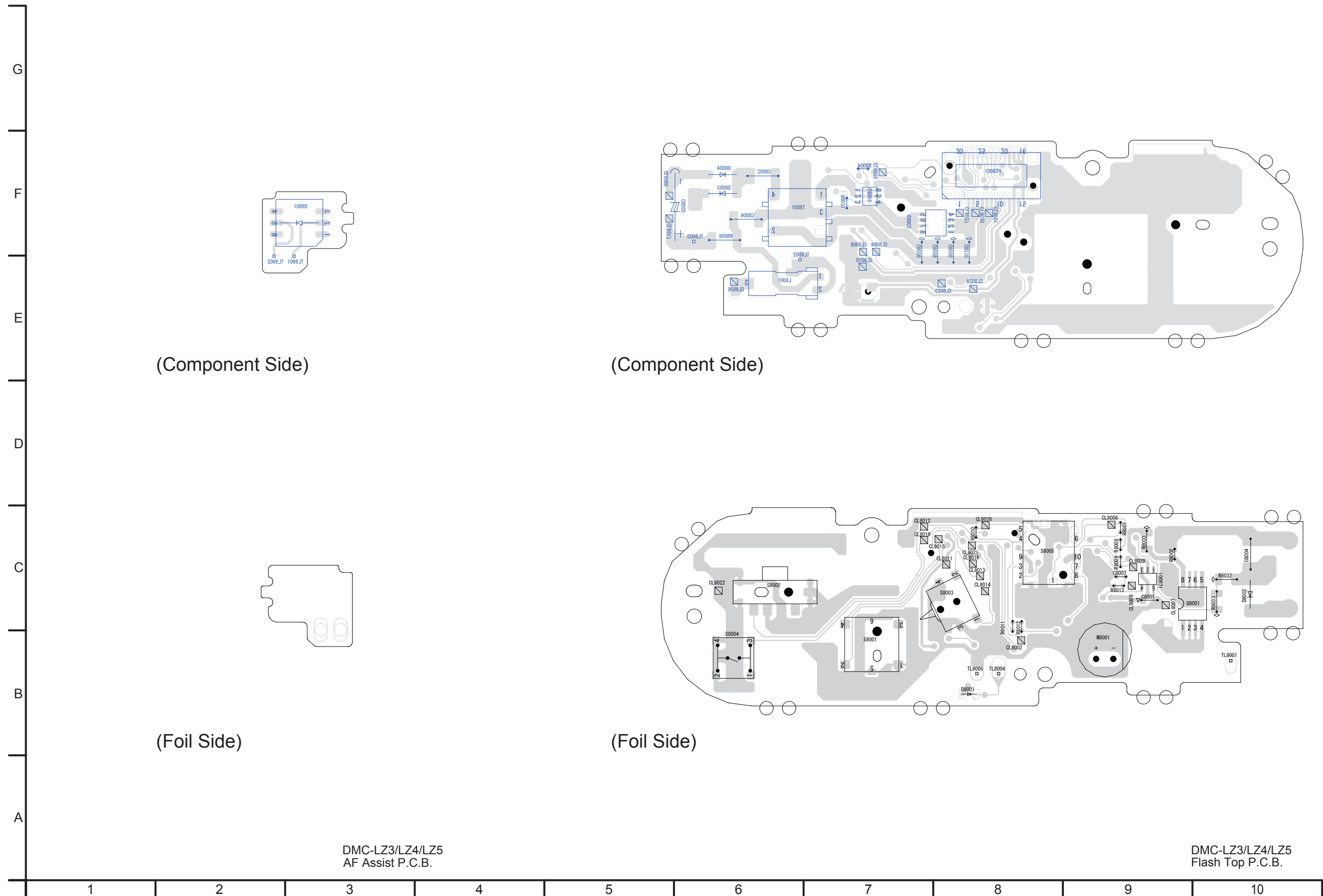

(Component Side)

(Component Side)

(Foil Side)

(Foil Side)

DMC-LZ3/LZ4/LZ5
AF Assist P.C.B.

DMC-LZ3/LZ4/LZ5
Flash Top P.C.B.

S5.3. Lens Flex P.C.B.

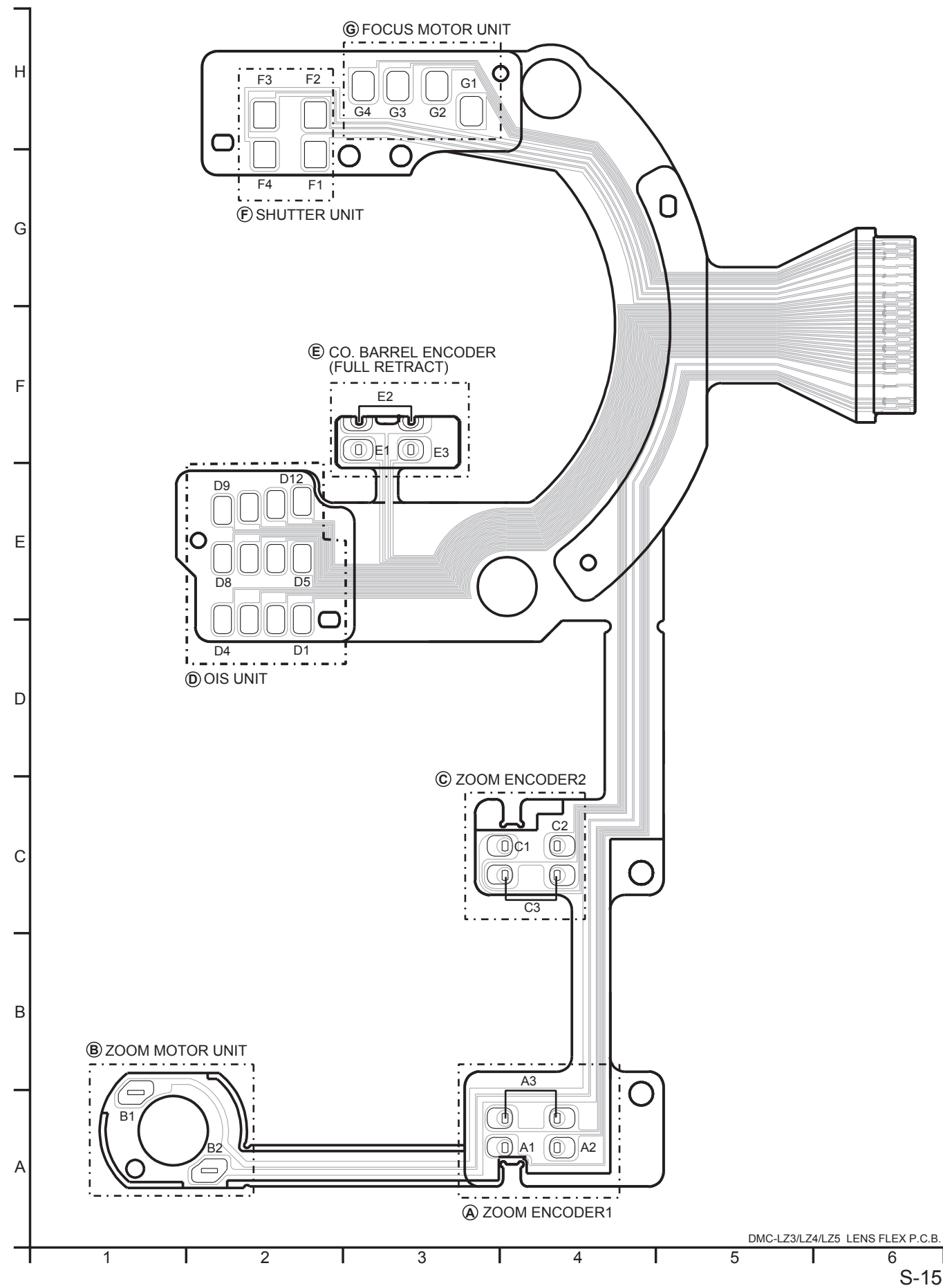

S5.4. CCD Flex P.C.B.

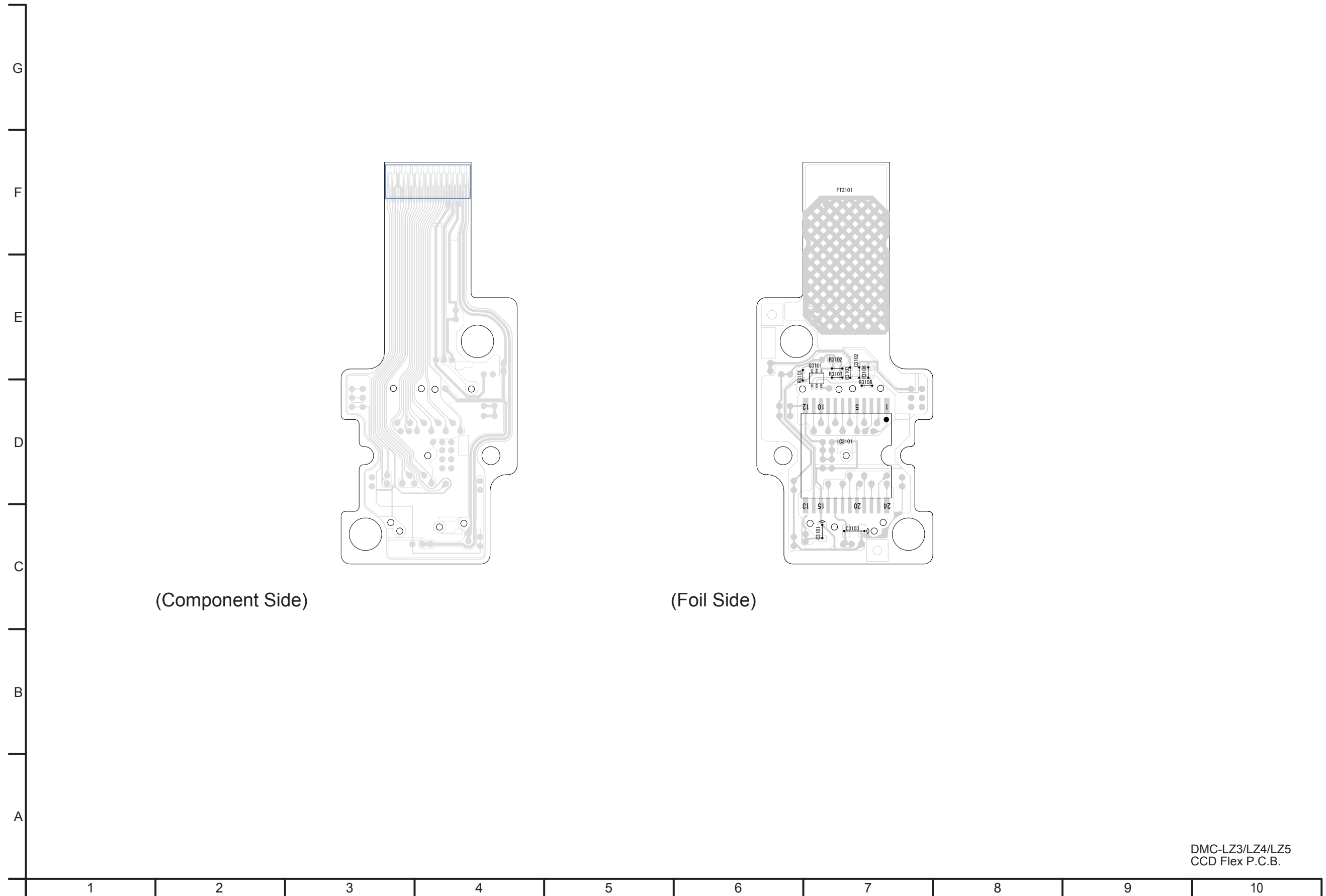

DMC-LZ3/LZ4/LZ5
CCD Flex P.C.B.

S6. Replacement Parts List

- Note: 1.* Be sure to make your orders of replacement parts according to this list.
2. IMPORTANT SAFETY NOTICE
Components identified with the mark \triangle have the special characteristics for safety.
When replacing any of these components, use only the same type.
3. Unless otherwise specified,
All resistors are in OHMS, K=1,000 OHMS. All capacitors are in MICRO-FARADS (uf), P=uuF.
4. The marking (RTL) indicates the retention time is limited for this item. After the discontinuation of this assembly in production, it will no longer be available.

E.S.D. standards for Electrostatically Sensitive Devices, refer to “PREVENTION OF ELECTROSTATIC DISCHARGE (ESD) TO ELECTROSTATICALLY SENSITIVE (ES) DEVICES” section.

DMC-LZ3PP/EB/EG/EF/EE/EGM/GT/PL/GN/GK/GC, LZ4PP/EB/EG, LZ5PP/EB/EG/EF/EE/EGM/GT/PL/GN/GK/GC/SG/SEPP

Ref.No.	Part No.	Part Name & Description	Pcs	Remarks
1	VEP56028A	MAIN P.C.B.	1	E.S.D.[RTL] LZ3,LZ4
1	VEP56028B	MAIN P.C.B.	1	E.S.D.[RTL] LZ5
2	VGQ8788	JACK BASE	1	LZ3,LZ4
2	VGQ8806	JACK BASE	1	LZ5(SILVER/GRAY)
2	VGQ8807	JACK BASE	1	LZ5(BLACK)
3	VKF4072	JACK COVER	1	LZ3,LZ4,LZ5(SILVER)
3	VKF4075	JACK COVER	1	LZ5(BLACK)
3	VKF4099	JACK COVER	1	LZ5(GRAY)
4	VMC1996	JACK SPRING	1	
5	VMS7709	JACK SHAFT	1	
6	VMS7702	BATTERY DOOR SHAFT	1	[ASPC]
7	VYF3077	BATTERY DOOR UNIT	1	[ASPC]LZ5(BLACK)
7	VYF3074	BATTERY DOOR UNIT	1	[ASPC]LZ3,LZ4,LZ5(SILVER)
7	VYF3091	BATTERY DOOR UNIT	1	[ASPC]LZ5(GRAY)
8	VYK1T89	BATTERY CASE UNIT	1	[ASPC]
9	L0DCDD000008	BUZZER	1	[ASPC]
11	EFN-FST35	FLASH UNIT	1	[ASPC]
12	F2A2F1010006	CAPACITOR	1	[ASPC](C8003)
13	VEP58018B	FLASH TOP P.C.B.	1	[ASPC][RTL]E.S.D. LZ5
13	VEP58018A	FLASH TOP P.C.B.	1	[ASPC][RTL]E.S.D. LZ3,LZ4
14	VEP59022A	AF ASSIST P.C.B.	1	[ASPC][RTL]E.S.D.
16	VGL1182	AF PANEL	1	[ASPC]
17	VGQ8789-1	FLASH COVER	1	[ASPC]
18	VGU9946	POWER KNOB	1	[ASPC]LZ5(BLACK)
18	VGU9941	POWER KNOB	1	[ASPC]LZ3,LZ4, LZ5(SILVER/GRAY)
19	VGU9948	OIS KNOB	1	[ASPC]LZ5(BLACK)
19	VGU9943	OIS KNOB	1	[ASPC]LZ3,LZ4, LZ5(SILVER/GRAY)
21	VMT1735	MIC DUMPER	1	[ASPC]LZ5
23	VXU1643	TOP CASE UNIT	1	[ASPC]LZ5(BLACK)
23	VXU1642	TOP CASE UNIT	1	[ASPC]LZ5(SILVER/GRAY)
23	VXU1641	TOP CASE UNIT	1	[ASPC]LZ3
23	VXU1649	TOP CASE UNIT	1	[ASPC]LZ4
24	WM-E13UT110	MICROPHONE UNIT	1	[ASPC]LZ5 (M8001)
25	VGL1180	LED PANEL	1	
26	VGQ8903	REAR SHEET	1	
27	VGU9939	REAR KNOB	1	LZ3,LZ4, LZ5(SILVER/GRAY)
27	VGU9944	REAR KNOB	1	LZ5(BLACK)
28	VKF4071	SD COVER	1	LZ3,LZ4,LZ5(SILVER)
28	VKF4074	SD COVER	1	LZ5(BLACK)
28	VKF4098	SD COVER	1	LZ5(GRAY)
29	VMA0U54	EARTH PLATE	1	
30	VMA0U55	LCD HOLDER	1	
31	VMA0U56	SD EARTH PLATE	1	
32	VMD5272	STAND HOLDER	1	LZ3,LZ4,LZ5(SILVER/GRAY)
32	VMD5309	STAND HOLDER	1	LZ5(BLACK)
33	VMS7701	SD SHAFT	1	
34	VYK1T88	REAR CASE UNIT	1	LZ3
34	VYK1T94	REAR CASE UNIT	1	LZ4,LZ5(SILVER)
34	VYK1T92	REAR CASE UNIT	1	LZ5(BLACK)
34	VYK1W06	REAR CASE UNIT	1	LZ5(GRAY)
35	VYQ3676	LCD UNIT	1	LZ3
35	VYQ3677	LCD UNIT	1	LZ4,LZ5
36	VYK1T86	FRONT CASE UNIT	1	LZ3,LZ4
36	VYK1U21	FRONT CASE UNIT	1	LZ5(SILVER)
36	VYK1T90	FRONT CASE UNIT	1	LZ5(BLACK)
36	VYK1W04	FRONT CASE UNIT	1	LZ5(GRAY)
37	VGQ8786	GRIP BASE	1	
38	VGQ8787	GRIP PIECE	1	LZ3,LZ4
38	VGQ8814	GRIP PIECE	1	LZ5(SILVER/BLACK)
38	VGQ8787	GRIP PIECE	1	LZ5(GRAY)

Ref.No.	Part No.	Part Name & Description	Pcs	Remarks
B1	VHD1759	SCREW	1	
B2	XQN17+BJ5FN	SCREW	1	
B3	XQN17+BJ5FN	SCREW	1	
B4	XQN17+BJ5FN	SCREW	1	
B5	VHD1759-1	SCREW	1	[ASPC]
B6	VHD1759-1	SCREW	1	[ASPC]
B7	VHD1759-1	SCREW	1	[ASPC]
B8	VHD1759	SCREW	1	
B9	XQN17+BJ5FN	SCREW	1	LZ3,LZ4, LZ5(SILVER/GRAY)
B9	XQN17+BJ5FJK	SCREW	1	LZ5(BLACK)
B10	XQN17+BJ5FN	SCREW	1	LZ3,LZ4, LZ5(SILVER/GRAY)
B10	XQN17+BJ5FJK	SCREW	1	LZ5(BLACK)
B11	XQN17+BJ5FN	SCREW	1	LZ3,LZ4, LZ5(SILVER/GRAY)
B11	XQN17+BJ5FJK	SCREW	1	LZ5(BLACK)
B12	XQN17+BJ5FN	SCREW	1	LZ3,LZ4, LZ5(SILVER/GRAY)
B12	XQN17+BJ5FJK	SCREW	1	LZ5(BLACK)
B13	XQN17+BJ5FN	SCREW	1	LZ3,LZ4, LZ5(SILVER/GRAY)
B13	XQN17+BJ5FJK	SCREW	1	LZ5(BLACK)
B14	XQN17+BJ5FN	SCREW	1	LZ3,LZ4, LZ5(SILVER/GRAY)
B14	XQN17+BJ5FJK	SCREW	1	LZ5(BLACK)
B15	XQN17+BJ5FN	SCREW	1	LZ3,LZ4, LZ5(SILVER/GRAY)
B15	XQN17+BJ5FJK	SCREW	1	LZ5(BLACK)
B16	XQN17+BJ5FN	SCREW	1	LZ3,LZ4, LZ5(SILVER/GRAY)
B16	XQN17+BJ5FJK	SCREW	1	LZ5(BLACK)
B20	XQN17+BJ5FN	SCREW	1	

DMC-LZ3PP/EB/EG/EF/EE/EGM/GT/PL/GN/GK/GC, LZ4PP/EB/EG, LZ5PP/EB/EG/EF/EE/EGM/GT/PL/GN/GK/GC/SG/SEPP

Ref.No.	Part No.	Part Name & Description	Pcs	Remarks
200	VPF1221	CAMERA BAG	1	
202	K1HA08CD0007	USB CABLE	1	
203	K1HA08CD0009	V CABLE	1	LZ3,LZ4
203	K1HA08CD0008	AV CABLE	1	LZ5
204	VFC4090	HAND STRAP	1	
205	VFF0311-S	CD-ROM	1	LZ3,LZ4(PP) LZ5(PP/SEPP) (SEE NOTES)
205	VFF0312-S	CD-ROM	1	LZ3,LZ4(EXCEPT PP) LZ5(EXCEPT PP/SEPP) (SEE NOTES)
206	VPK3084	PACKING CASE	1	LZ3PP-S
206	VPK3085	PACKING CASE	1	LZ3EB-S/EG-S/EF-S/EE-S/ EGM-S/GT-S/PL-S/ GN-S/GC-S
206	VPK3086	PACKING CASE	1	LZ3GK-S
206	VPK3124	PACKING CASE	1	LZ4PP-S
206	VPK3125	PACKING CASE	1	LZ4EB-S/EG-S
206	VPK3081	PACKING CASE	1	LZ5PP-S
206	VPK3093	PACKING CASE	1	LZ5PP-K
206	VPK3082	PACKING CASE	1	LZ5EB-S/EG-S/EF-S/EE-S/ EGM-S/GT-S/PL-S/GN-S/ GC-S/SG-S
206	VPK3094	PACKING CASE	1	LZ5EB-K/EG-K/EF-K/EE-K/ EGM-K/GN-K/GC-K
206	VPK3083	PACKING CASE	1	LZ5GK-S
206	VPK3143	PACKING CASE	1	LZ5EE-H/SEPP-H
207	VPN6388	PAD	1	
209	VPF1100	POLY BAG	1	LZ3PP/EB/EF/EE/GT/GN/GK, LZ4PP/EB/EG, LZ5PP/EB/EF/EE/GT/GN/GK/SEPP
209	VPF1132	POLY BAG	1	LZ3EG/EGM/PL/GC, LZ5EG/EGM/PL/GC/SG
210	VQT0X00	O/I SOFTWARE (ENGLISH/CANADIAN FRENCH)	1	LZ3PP,LZ4PP,LZ5PP/SEPP
210	VQT0X04	O/I SOFTWARE (ENGLISH)	1	LZ3EB,LZ4EB,LZ5EB
210	VQT0X01	O/I SOFTWARE (GERMAN/FRENCH/ ITALIAN/DUTCH)	1	LZ3EG,LZ5EG
210	VQT0X03	O/I SOFTWARE (FRENCH)	1	LZ3EF,LZ5EF
210	VQT0X08	O/I SOFTWARE (RUSSIAN/UR)	1	LZ3EE,LZ5EE
210	VQT0X02	O/I SOFTWARE (SPANISH/PORTUGUESE/ SWEDISH/DANISH)	1	LZ3EGM,LZ5EGM
210	VQT0X10	O/I SOFTWARE (CHINESE(TRADITIONAL))	1	LZ3GT,LZ5GT
210	VQT0X09	O/I SOFTWARE (ENGLISH/SPANISH/ PORTUGUESE)	1	LZ3PL,LZ5PL
210	VQT0X07	O/I SOFTWARE (ENGLISH)	1	LZ3GN,LZ5GN
210	VQT0X06	O/I SOFTWARE (CHINESE(SIMPLIFIED))	1	LZ3GK,LZ5GK
210	VQT0X05	O/I SOFTWARE (ENGLISH/ CHINESE(TRADITIONAL)/ ARABIC)	1	LZ3GC,LZ5GC/SG
210	VQT0W39	O/I SOFTWARE (GERMAN/FRENCH)	1	LZ4EG
△ 211	VQT0U87	INSTRUCTION BOOK (ENGLISH)	1	LZ3PP,LZ4PP,LZ5PP/SEPP
△ 211	VQT0U88	INSTRUCTION BOOK (CANADIAN FRENCH)	1	LZ3PP,LZ4PP,LZ5PP/SEPP
△ 211	VQT0V00	INSTRUCTION BOOK (ENGLISH)	1	LZ3EB,LZ4EB,LZ5EB
△ 211	VQT0U92	INSTRUCTION BOOK (GERMAN)	1	LZ3EG,LZ4EG,LZ5EG
△ 211	VQT0U95	INSTRUCTION BOOK (DUTCH)	1	LZ3EG,LZ5EG
△ 211	VQT0U93	INSTRUCTION BOOK (FRENCH)	1	LZ3EG/EF,LZ4EG,LZ5EG/EF

Ref.No.	Part No.	Part Name & Description	Pcs	Remarks
△ 211	VQT0U94	INSTRUCTION BOOK (ITALIAN)	1	LZ3EG,LZ5EG
△ 211	VQT0V03	INSTRUCTION BOOK (RUSSIAN)	1	LZ3EE,LZ5EE
△ 211	VQT0W21	INSTRUCTION BOOK (UR)	1	LZ3EE,LZ5EE
△ 211	VQT0U96	INSTRUCTION BOOK (SPANISH)	1	LZ3EGM,LZ5EGM
△ 211	VQT0U98	INSTRUCTION BOOK (SWEDISH)	1	LZ3EGM,LZ5EGM
△ 211	VQT0U99	INSTRUCTION BOOK (DANISH)	1	LZ3EGM,LZ5EGM
△ 211	VQT0U97	INSTRUCTION BOOK (PORTUGUESE)	1	LZ3EGM,LZ5EGM
△ 211	VQT0V05	INSTRUCTION BOOK (CHINESE(TRADITIONAL))	1	LZ3GT,LZ5GT
△ 211	VQT0U89	INSTRUCTION BOOK (ENGLISH)	1	LZ3PL,LZ5PL
△ 211	VQT0U90	INSTRUCTION BOOK (SPANISH)	1	LZ3PL,LZ5PL
△ 211	VQT0U91	INSTRUCTION BOOK (PORTUGUESE)	1	LZ3PL,LZ5PL
△ 211	VQT0V07	INSTRUCTION BOOK (ENGLISH)	1	LZ3GN,LZ5GN
△ 211	VQT0V06	INSTRUCTION BOOK (CHINESE(SIMPLIFIED))	1	LZ3GK,LZ5GK
△ 211	VQT0V01	INSTRUCTION BOOK (ENGLISH)	1	LZ3GC,LZ5GC/SG
△ 211	VQT0V02	INSTRUCTION BOOK (CHINESE(TRADITIONAL))	1	LZ3GC,LZ5GC/SG
△ 211	VQT0V04	INSTRUCTION BOOK (ARABIC/RUSSIAN)	1	LZ3GC,LZ5GC/SG
212	VQT0W41	O/I PC CONNECTION (ENGLISH/SPANISH/ CANADIAN FRENCH)	1	LZ3PP,LZ4PP,LZ5PP/SEPP
212	VQT0W46	O/I PC CONNECTION (ENGLISH)	1	LZ3EB,LZ4EB,LZ5EB
212	VQT0W43	O/I PC CONNECTION (GERMAN/FRENCH/ ITALIAN/DUTCH)	1	LZ3EG,LZ5EG
212	VQT0W45	O/I PC CONNECTION (FRENCH)	1	LZ3EF,LZ5EF
212	VQT0W14	O/I PC CONNECTION (RUSSIAN/UR)	1	LZ3EE,LZ5EE
212	VQT0W44	O/I PC CONNECTION (SPANISH/PORTUGUESE/ SWEDISH/DANISH)	1	LZ3EGM,LZ5EGM
212	VQT0W48	O/I PC CONNECTION (CHINESE(TRADITIONAL))	1	LZ3GT,LZ5GT
212	VQT0W42	O/I PC CONNECTION (ENGLISH/SPANISH/ PORTUGUESE)	1	LZ3PL,LZ5PL
212	VQT0W50	O/I PC CONNECTION (ENGLISH)	1	LZ3GN,LZ5GN
212	VQT0W49	O/I PC CONNECTION (CHINESE(SIMPLIFIED))	1	LZ3GK,LZ5GK
212	VQT0W47	O/I PC CONNECTION (ENGLISH/ CHINESE(TRADITIONAL)/ ARABIC)	1	LZ3GC,LZ5GC/SG
212	VQT0W38	O/I PC CONNECTION (GERMAN/FRENCH)	1	LZ4EG

S7. Exploded View

S7.1. Frame and Casing Section (1)

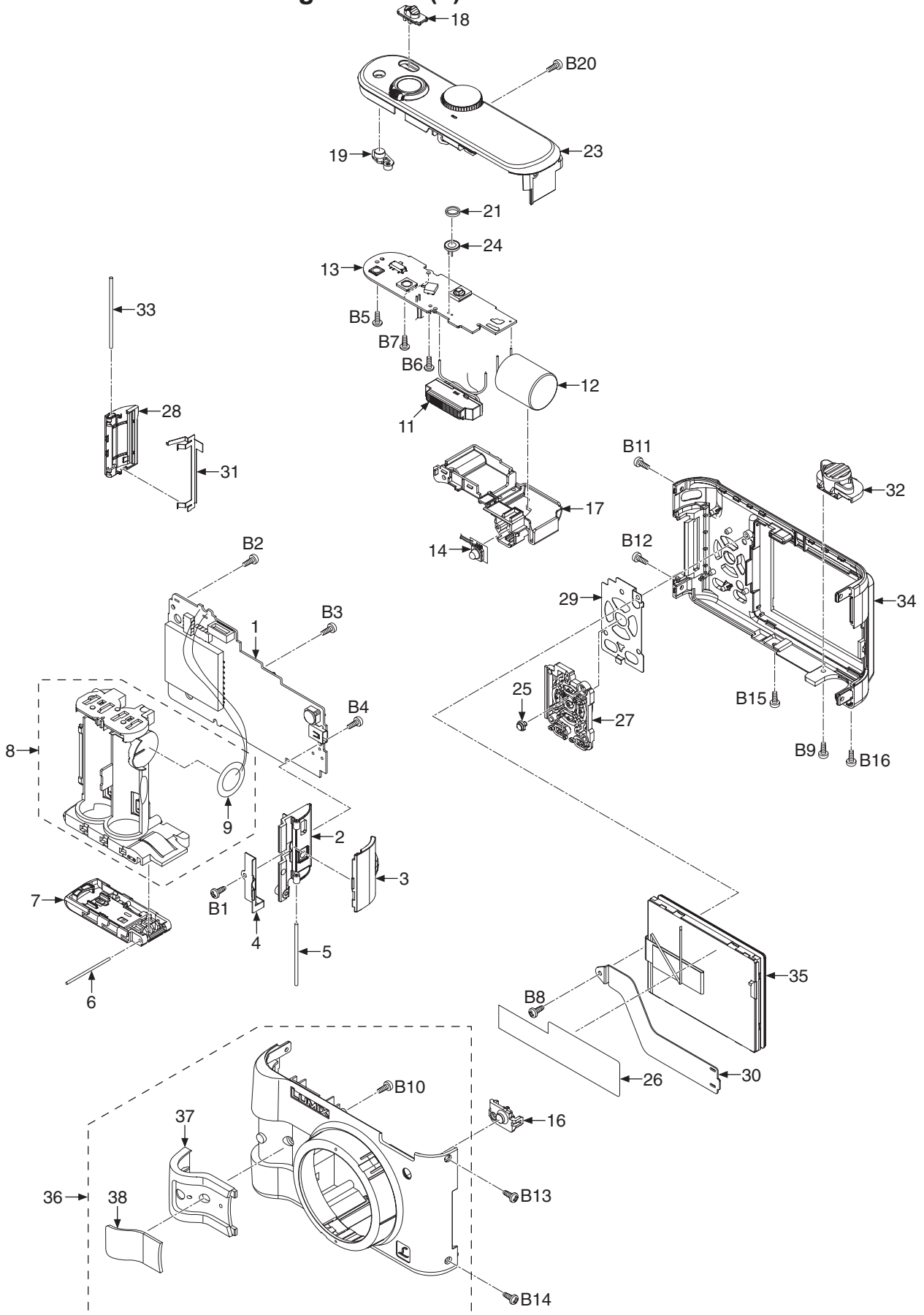

S7.2. Frame and Casing Section (2)

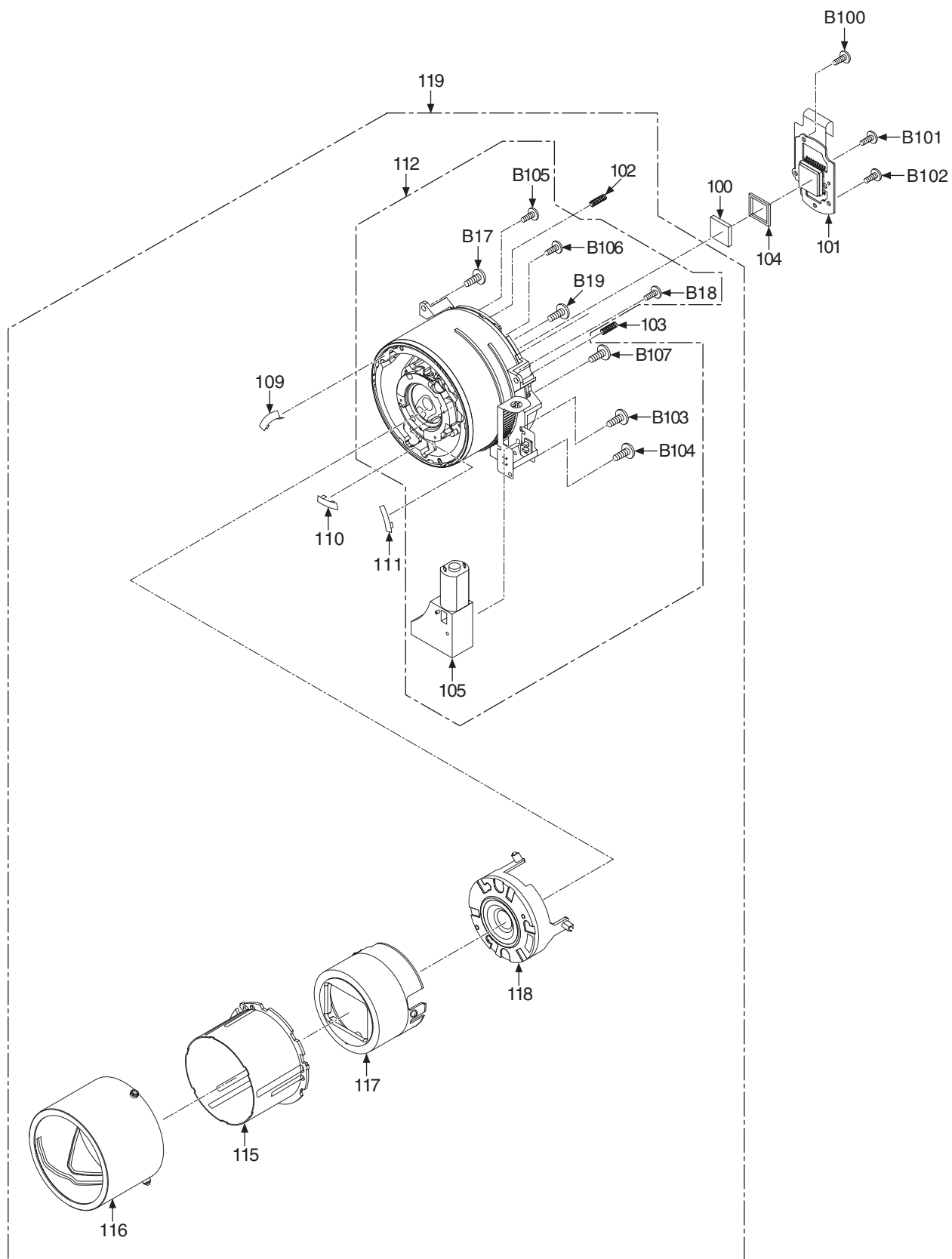

S7.3. Packing Parts and Accessories Section

