

Service Manual

Digital Camera/Lens Kit/Body

LUMIX



HDMI

VIERA Link™



Model No. **DMC-G2KPP**

DMC-G2KEB

DMC-G2KEC

DMC-G2KEG

DMC-G2KGC

DMC-G2KGD

DMC-G2KGH

DMC-G2KGT

DMC-G2K GK

DMC-G2KGN

DMC-G2WEB

DMC-G2WEC

DMC-G2WEG

DMC-G2WGC

DMC-G2WGH

DMC-G2WGN

DMC-G2EB

DMC-G2EC

DMC-G2EG

DMC-G2GC

DMC-G2GH

DMC-G2GN

Panasonic®

Vol.1

Colour

[DMC-G2K]

(K).....Black Type

(R).....Red Type (except GD/GT/GN)

(A).....Blue Type (except GD/GT/GN)

[DMC-G2W]

(K).....Black Type

(R).....Red Type (except GC/GH/GN)

(A).....Blue Type (except GC/GH/GN)

[DMC-G2]

(K).....Black Type

WARNING

This service information is designed for experienced repair technicians only and is not designed for use by the general public. It does not contain warnings or cautions to advise non-technical individuals of potential dangers in attempting to service a product. Products powered by electricity should be serviced or repaired only by experienced professional technicians. Any attempt to service or repair the product or products dealt with in this service information by anyone else could result in serious injury or death.

TABLE OF CONTENTS

	PAGE		PAGE
1 Safety Precautions	3	11 Maintenance	47
1.1. General Guidelines	3	11.1. Notice in external cleaning	47
1.2. Leakage Current Cold Check	3	11.2. General description (Lens cleaning: Interchangeable Lens/H-FS014042).....	48
1.3. Leakage Current Hot Check (See Figure 1.).....	3	11.3. eneral description (Lens cleaning: Interchangeable Lens/H-FS045200).....	51
1.4. How to Discharge the E. Capacitor on POW Flash P.C.B.	4		
2 Warning	5		
2.1. Prevention of Electrostatic Discharge (ESD) to Electrostatically Sensitive (ES) Devices	5		
2.2. How to Recycle the Lithium Ion Battery (U.S. Only).....	5		
2.3. Caution for AC Cord (For EB/GC/GH)	6		
2.4. How to Replace the Lithium Battery.....	7		
3 Service Navigation	8		
3.1. Introduction	8		
3.2. Important Notice.....	8		
3.3. General Description About Lead Free Solder (PbF)	12		
3.4. How to Define the Model Suffix (NTSC or PAL model).....	13		
4 Specifications	16		
5 Location of Controls and Components	17		
6 Service Mode	22		
6.1. Error Code Memory Function	22		
7 Troubleshooting Guide	24		
7.1. Checking Method of Body and Interchangeable Lens	24		
8 Service Fixture & Tools	29		
8.1. Service Fixture and Tools	29		
8.2. Clean Box	30		
8.3. Service Position	31		
9 Disassembly and Assembly Instructions	33		
9.1. Camera Body Part	33		
9.2. Disassembly and Assemble Procedure for the Lens (H-FS014042).....	43		
9.3. Disassembly and Assemble Procedure for the Lens (H-FS045200).....	44		
10 Measurements and Adjustments	45		
10.1. Matrix Chart for Replaced Part and Necessary Adjustment.....	45		

1 Safety Precautions

1.1. General Guidelines

1. IMPORTANT SAFETY NOTICE

There are special components used in this equipment which are important for safety. These parts are marked by

 in the Schematic Diagrams, Circuit Board Layout, Exploded Views and Replacement Parts List. It is essential that these critical parts should be replaced with manufacturer's specified parts to prevent X-RADIATION, shock, fire, or other hazards. Do not modify the original design without permission of manufacturer.

2. An Isolation Transformer should always be used during the servicing of AC Adaptor whose chassis is not isolated from the AC power line. Use a transformer of adequate power rating as this protects the technician from accidents resulting in personal injury from electrical shocks. It will also protect AC Adaptor from being damaged by accidental shorting that may occur during servicing.
3. When servicing, observe the original lead dress. If a short circuit is found, replace all parts which have been overheated or damaged by the short circuit.
4. After servicing, see to it that all the protective devices such as insulation barriers, insulation papers shields are properly installed.
5. After servicing, make the following leakage current checks to prevent the customer from being exposed to shock hazards.

1.2. Leakage Current Cold Check

1. Unplug the AC cord and connect a jumper between the two prongs on the plug.
2. Measure the resistance value, with an ohmmeter, between the jumpered AC plug and each exposed metallic cabinet part on the equipment such as screwheads, connectors, control shafts, etc. When the exposed metallic part has a return path to the chassis, the reading should be between $1\text{ M}\Omega$ and $5.2\text{ M}\Omega$. When the exposed metal does not have a return path to the chassis, the reading must be infinity.

1.3. Leakage Current Hot Check (See Figure 1.)

1. Plug the AC cord directly into the AC outlet. Do not use an isolation transformer for this check.
2. Connect a $1.5\text{ k}\Omega$, 10 W resistor, in parallel with a $0.15\text{ }\mu\text{F}$ capacitor, between each exposed metallic part on the set and a good earth ground, as shown in Figure 1.
3. Use an AC voltmeter, with $1\text{ k}\Omega/\text{V}$ or more sensitivity, to measure the potential across the resistor.
4. Check each exposed metallic part, and measure the voltage at each point.
5. Reverse the AC plug in the AC outlet and repeat each of the above measurements.
6. The potential at any point should not exceed 0.75 V RMS . A leakage current tester (Simpson Model 229 or equivalent) may be used to make the hot checks, leakage current must not exceed $1/2\text{ mA}$. In case a measurement is outside of the limits specified, there is a possibility of a shock hazard, and the equipment should be repaired and rechecked before it is returned to the customer.

Hot-Check Circuit



Figure. 1

1.4. How to Discharge the E. Capacitor on POW Flash P.C.B.

CAUTION:

1. Be sure to discharge the E. Capacitor on POW FLASH P.C.B..
2. Be careful of the high voltage circuit on POW FLASH P.C.B. when servicing.

[Discharging Procedure]

1. Refer to the disassemble procedure and remove the necessary parts/unit.
2. Put the insulation tube onto the lead part of Resistor (ERG5SJ102:1k Ω /5W).
(An equivalent type of resistor may be used.)
3. Put the resistor between both terminals of E. Capacitor on POW FLASH P.C.B. for approx. 5 seconds.
4. After discharging confirm that the E. Capacitor voltage is lower than 10V using a voltmeter.

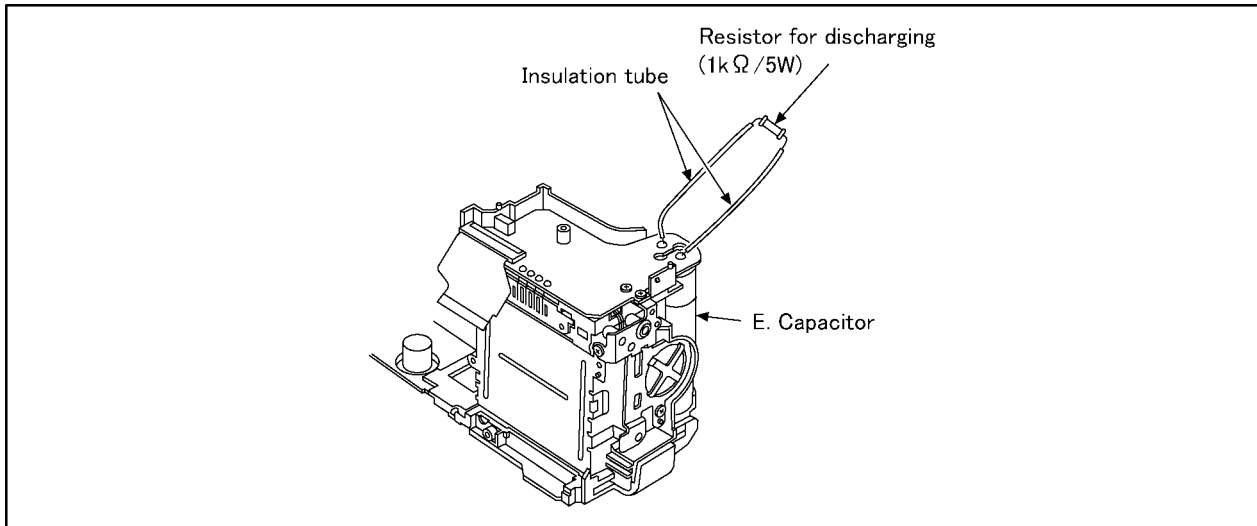

Fig. F1

2 Warning

2.1. Prevention of Electrostatic Discharge (ESD) to Electrostatically Sensitive (ES) Devices

Some semiconductor (solid state) devices can be damaged easily by static electricity. Such components commonly are called Electrostatically Sensitive (ES) Devices.

Examples of typical ES devices are IC (integrated circuits) and some field-effect transistors and semiconductor "chip" components.

The following techniques should be used to help reduce the incidence of component damage caused by electrostatic discharge (ESD).

1. Immediately before handling any semiconductor component or semiconductor-equipped assembly, drain off any ESD on your body by touching a known earth ground. Alternatively, obtain and wear a commercially available discharging ESD wrist strap, which should be removed for potential shock reasons prior to applying power to the unit under test.
2. After removing an electrical assembly equipped with ES devices, place the assembly on a conductive surface such as aluminum foil, to prevent electrostatic charge buildup or exposure of the assembly.
3. Use only a grounded-tip soldering iron to solder or unsolder ES devices.
4. Use only an antistatic solder removal device. Some solder removal devices not classified as "antistatic (ESD protected)" can generate electrical charge sufficient to damage ES devices.
5. Do not use freon-propelled chemicals. These can generate electrical charges sufficient to damage ES devices.
6. Do not remove a replacement ES device from its protective package until immediately before you are ready to install it. (Most replacement ES devices are packaged with leads electrically shorted together by conductive foam, aluminum foil or comparable conductive material).
7. Immediately before removing the protective material from the leads of a replacement ES device, touch the protective material to the chassis or circuit assembly into which the device will be installed.

CAUTION :

Be sure no power is applied to the chassis or circuit, and observe all other safety precautions.

8. Minimize bodily motions when handling unpackaged replacement ES devices. (Otherwise harmless motion such as the brushing together of your clothes fabric or the lifting of your foot from a carpeted floor can generate static electricity (ESD) sufficient to damage an ES device).

2.2. How to Recycle the Lithium Ion Battery (U.S. Only)

ENGLISH



A lithium ion battery that is recyclable powers the product you have purchased. Please call 1-800-8-BATTERY for information on how to recycle this battery.

FRANÇAIS



L'appareil que vous vous êtes procuré est alimenté par une batterie au lithium-ion recyclable. Pour des renseignements sur le recyclage de la batterie, veuillez composer le 1-800-8-BATTERY.

2.3. Caution for AC Cord (For EB/GC/GH)

2.3.1. Information for Your Safety

IMPORTANT

Your attention is drawn to the fact that recording of pre-recorded tapes or discs or other published or broadcast material may infringe copyright laws.

WARNING

To reduce the risk of fire or shock hazard, do not expose this equipment to rain or moisture.

CAUTION

To reduce the risk of fire or shock hazard and annoying interference, use the recommended accessories only.

FOR YOUR SAFETY

DO NOT REMOVE THE OUTER COVER

To prevent electric shock, do not remove the cover. No user serviceable parts inside. Refer servicing to qualified service personnel.

2.3.2. Caution for AC Mains Lead

For your safety, please read the following text carefully.

This appliance is supplied with a moulded three-pin mains plug for your safety and convenience.

A 5-ampere fuse is fitted in this plug.

Should the fuse need to be replaced please ensure that the replacement fuse has a rating of 5 amperes and it is approved by ASTA or BSI to BS1362

Check for the ASTA mark or the BSI mark on the body of the fuse.



If the plug contains a removable fuse cover you must ensure that it is refitted when the fuse is replaced.

If you lose the fuse cover, the plug must not be used until a replacement cover is obtained.

A replacement fuse cover can be purchased from your local Panasonic Dealer.

If the fitted moulded plug is unsuitable for the socket outlet in your home then the fuse should be removed and the plug cut off and disposed of safely.

There is a danger of severe electrical shock if the cut off plug is inserted into any 13-ampere socket.

If a new plug is to be fitted please observe the wiring code as shown below.

If in any doubt, please consult a qualified electrician.

2.3.2.1. Important

The wires in this mains lead are coloured in accordance with the following code:

Blue	Neutral
Brown	Live

As the colours of the wires in the mains lead of this appliance may not correspond with the coloured markings identifying the terminals in your plug, proceed as follows:

The wire which is coloured BLUE must be connected to the terminal in the plug which is marked with the letter N or coloured BLACK.

The wire which is coloured BROWN must be connected to the terminal in the plug which is marked with the letter L or coloured RED.

Under no circumstances should either of these wires be connected to the earth terminal of the three pin plug, marked with the letter E or the Earth Symbol.

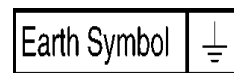

2.3.2.2. Before Use

Remove the Connector Cover as follows.



2.3.2.3. How to Replace the Fuse

1. Remove the Fuse Cover with a screwdriver.



2. Replace the fuse and attach the Fuse cover.



2.4. How to Replace the Lithium Battery

2.4.1. Replacement Procedure

1. Remove the REMOTE P.C.B.. (Refer to Disassembly Procedures.)
2. Unsolder the each soldering point of electric lead terminal for Lithium battery (Ref. No. "B7301" at component side of REMOTE P.C.B.) and remove the Lithium battery together with electric lead terminal. Then replace it into new one.

NOTE:

The Type No. ML421 includes electric lead terminals.

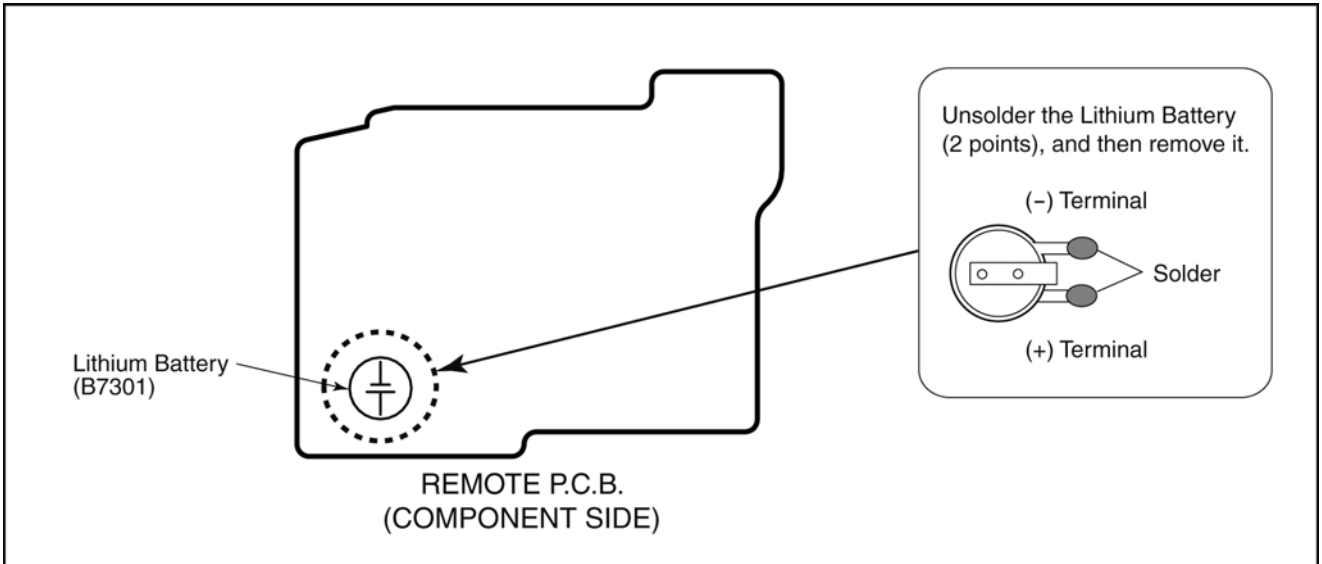

NOTE:

This Lithium battery is a critical component.

(Type No.: ML421 **Manufactured by Energy Company, Panasonic Corporation.**)

It must never be subjected to excessive heat or discharge.

It must therefore only be fitted in requirement designed specifically for its use.

Replacement batteries must be of same type and manufacture.

They must be fitted in the same manner and location as the original battery, with the correct polarity contacts observed.

Do not attempt to re-charge the old battery or re-use it for any other purpose.

It should be disposed of in waste products destined for burial rather than incineration.

(For English)

CAUTION

Danger of explosion if battery is incorrectly replaced.

Replace only with the same or equivalent type recommended by the manufacturer.

Dispose of used batteries according to the manufacturer's instructions.

(For German)

ACHTUNG

Explosionsgefahr bei falschem Anbringen der Batterie. Ersetzen Sie nur mit einem äquivalentem vom Hersteller empfohlenem Typ.

Behandeln Sie gebrauchte Batterien nach den Anweisungen des Herstellers.

(For French)

MISE EN GARDE

Une batterie de remplacement inappropriée peut exploser. Ne remplacez qu'avec une batterie identique ou d'un type recommandé par le fabricant. L'élimination des batteries usées doit être faite conformément aux instructions du fabricant.

NOTE:

Above caution is applicable for a battery pack which is for DMC-G2K/G2W/G2 series, as well.

3 Service Navigation

3.1. Introduction

This service manual contains technical information, which allow service personnel's to understand and service this model.

Please place orders using the parts list and not the drawing reference numbers.

If the circuit is changed or modified, the information will be followed by service manual to be controlled with original service manual.

3.2. Important Notice

*When servicing, it is recommended dealing with Clean box. (Refer to "8.2. Clean Box" section of this service manual for details.)

3.2.1. Camera Body Unit

3.2.1.1. About Mount Box Unit (Ref. 3)

1. This Service Manual does not contain the following repair service information for "MOUNT BOX UNIT"(Ref.3), because it requires special facilities and equipment.
 - a. Schematic diagram, Block diagram and P.C.B. layout.
 - b. Parts list for individual parts.
2. If the "MOUNT BOX UNIT" is confirmed as defective, exchange the "MOUNT BOX UNIT" as a unit (supplied as service parts size).
3. Before exchange the "MOUNT BOX UNIT", the performances must be carefully checked, by following the "7.Troubleshooting Guide" section of this service manual.

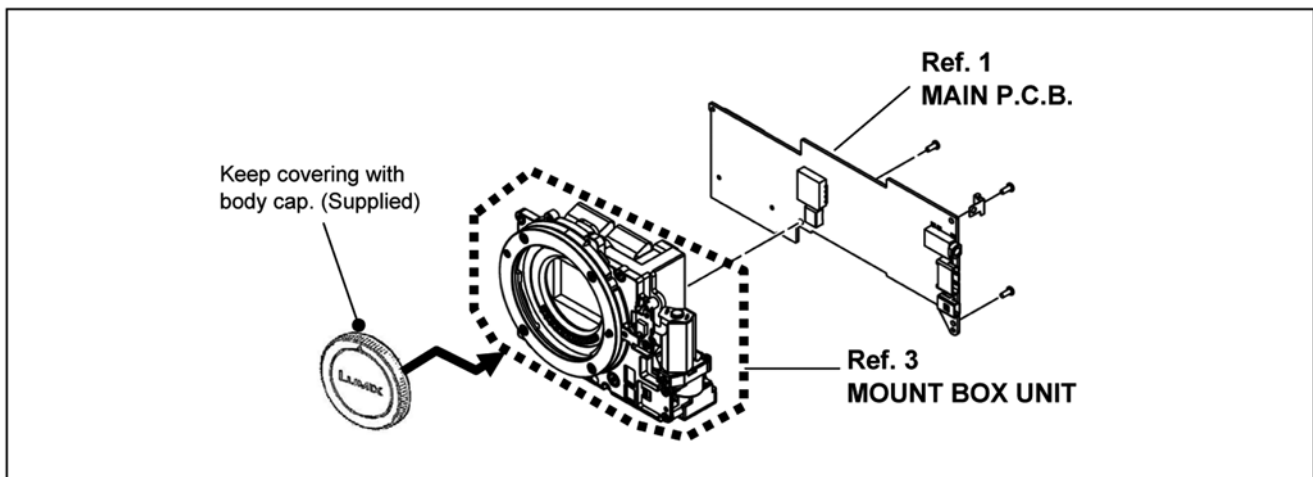

Fig. S1

Important:

1. After replacing the MOUNT BOX UNIT, the mount box data has to be stored to the unit.
When the serial number of the mount box unit which is put on the shield plate of mount box unit is entered to the adjustment unit, the applicable data is stored into the MAIN P.C.B..
Refer to the adjustment instruction in the adjustment software for details.

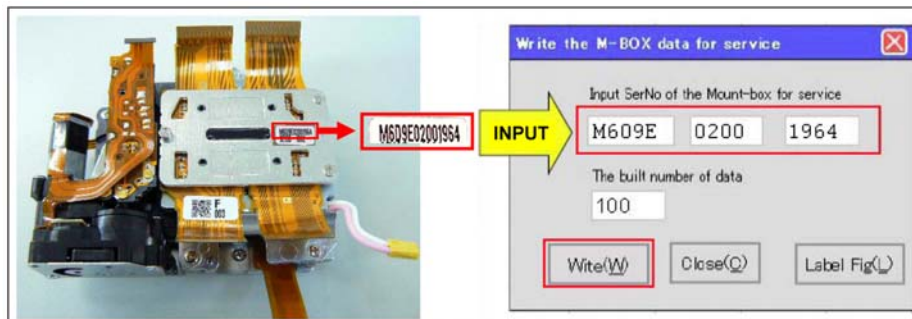

Fig. S2

2. The full adjustment must be performed after replacing the "MOUNT BOX UNIT", otherwise picture quality can not be meet with specification.

3.2.1.2. About Main P.C.B. (Ref. 1) / POW Flash P.C.B. (Ref. 52) / LCD IF P.C.B. (Ref. 42)

1. This Service Manual does not contain the following repair service information for "MAIN P.C.B."(Ref.1), "POW Flash P.C.B."(Ref.52) and "LCD IF P.C.B."(Ref.42), because it requires special facilities and equipment.
 - a. Schematic diagram, Block diagram and P.C.B. layout.
 - b. Parts list for individual parts.
2. When a part replacement is required for repairing "MAIN P.C.B.", "POW Flash P.C.B." and "LCD IF P.C.B.", replace as an assembled P.C.B. parts and send it/them to Central Repair Center.
3. The following category is recycle module part. Please send it/them to Central Repair Center.
 - *MAIN P.C.B. (VEP56106A: PP/GC/GD/GH/GK/GN/GT)
 - *MAIN P.C.B. (VEP56106B: EB/EC/EG)
 - *POW FLASH P.C.B. (VEP51027A)
 - *LCD IF P.C.B. (VEP59079A)

Important (About Main P.C.B.):

1. Before exchange the "MAIN P.C.B.", the performances must be carefully checked, by following the "7.Troubleshooting Guide" section of this service manual.
2. Before replacing the "MAIN P.C.B.", proceed the EEPROM data backup from the unit. After replacing the MAIN P.C.B., overwrite the EEPROM data with backup data from the unit first, then proceed the adjustment /inspection.
If it is impossible to make a data backup due to the unit does not turns on the power and so on, additional adjustment (using the light box) is required.
Refer to the adjustment instruction in the adjustment software for details.
3. The full adjustment must be performed after replacing the "MAIN P.C.B.", otherwise Picture quality can not be meet with specification.

3.2.2. Lens Unit (Interchangeable Lens: H-FS014042)

3.2.2.1. About Lens Main Block Unit (Ref. 208)

1. This Service Manual does not contain the repair service information for "LENS MAIN BLOCK UNIT"(Ref.208), because it requires special facilities and equipment.
2. The "LENS MAIN BLOCK UNIT"(Ref.208) performance must be confirmed.
3. In case of the "LENS MAIN BLOCK UNIT"(Ref.208) defect, contact to the service department of sales company.

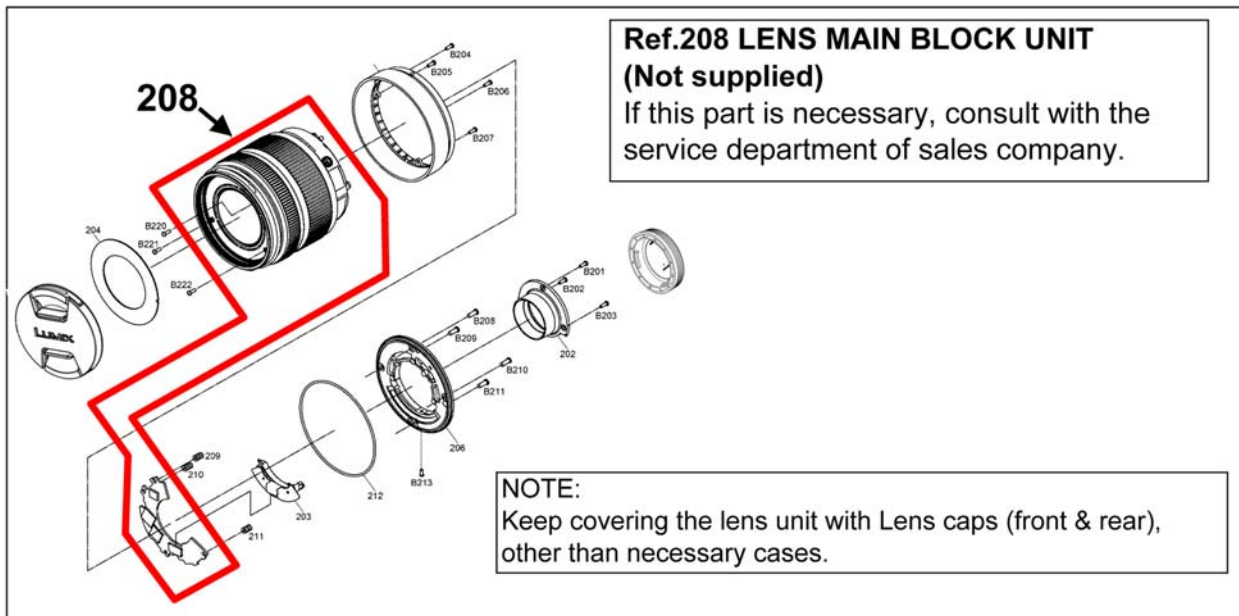

Fig. S3

3.2.3. Lens Unit (Interchangeable Lens: H-FS045200)

3.2.3.1. About Lens Main Block Unit (Ref. 308)

1. This Service Manual does not contain the repair service information for "LENS MAIN BLOCK UNIT"(Ref.308), because it requires special facilities and equipment.
2. The "LENS MAIN BLOCK UNIT"(Ref.308) performance must be confirmed.
3. In case of the "LENS MAIN BLOCK UNIT"(Ref.308) defect, contact to the service department of sales company.

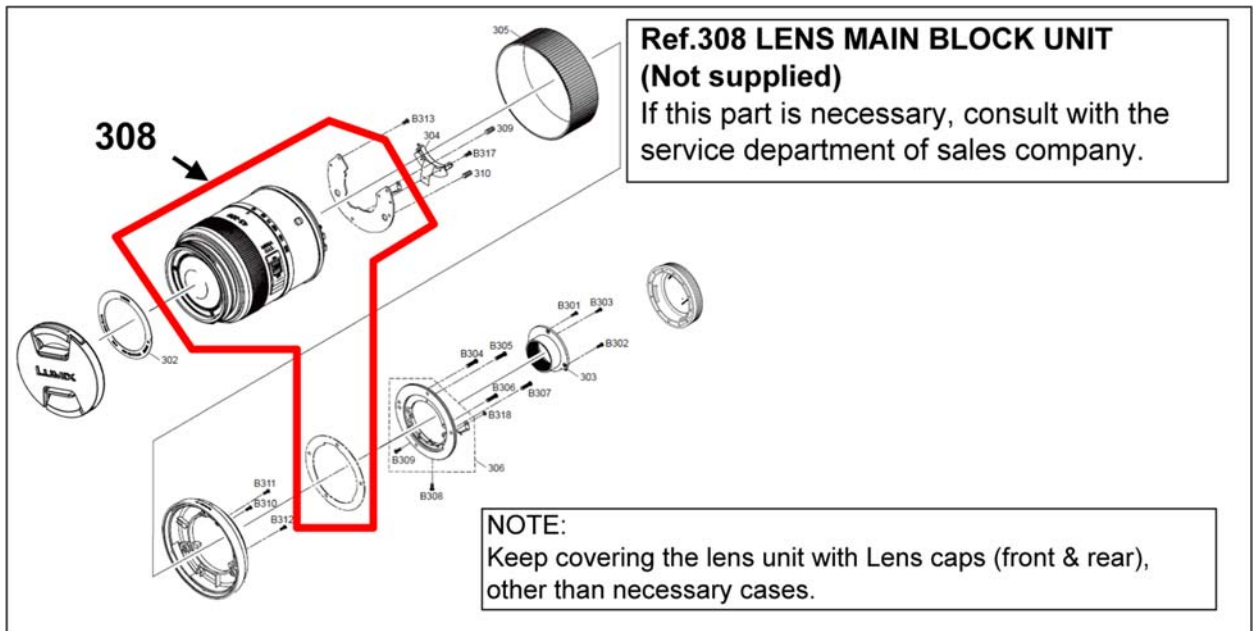

Fig. S4

3.2.4. About Flexible Cable and Connector

Do not touch carelessly so that the foreign body should not adhere to the terminal part of flexible cable and connector. Wipe off with a clean cloth and the cotton bud, etc. when the terminal part is dirty.

3.3. General Description About Lead Free Solder (PbF)

The lead free solder has been used in the mounting process of all electrical components on the printed circuit boards used for this equipment in considering the globally environmental conservation.

The normal solder is the alloy of tin (Sn) and lead (Pb). On the other hand, the lead free solder is the alloy mainly consists of tin (Sn), silver (Ag) and Copper (Cu), and the melting point of the lead free solder is higher approx.30°C (86°F) more than that of the normal solder.

Distinction of P.C.B. Lead Free Solder being used

The letter of "PbF" is printed either foil side or components side on the P.C.B. using the lead free solder.(See right figure)	PbF
--------------------------------------------------------------------------------------------------------------------------------	-----

Service caution for repair work using Lead Free Solder (PbF)

- The lead free solder has to be used when repairing the equipment for which the lead free solder is used.
(Definition: The letter of "PbF" is printed on the P.C.B. using the lead free solder.)
- To put lead free solder, it should be well molten and mixed with the original lead free solder.
- Remove the remaining lead free solder on the P.C.B. cleanly for soldering of the new IC.
- Since the melting point of the lead free solder is higher than that of the normal lead solder, it takes the longer time to melt the lead free solder.
- Use the soldering iron (more than 70W) equipped with the temperature control after setting the temperature at 350±30°C (662±86°F).

Recommended Lead Free Solder (Service Parts Route.)

- The following 3 types of lead free solder are available through the service parts route.
RFKZ03D01KS------(0.3mm 100g Reel)
RFKZ06D01KS------(0.6mm 100g Reel)
RFKZ10D01KS------(1.0mm 100g Reel)

Note

* Ingredient: tin (Sn) 96.5%, silver (Ag) 3.0%, Copper (Cu) 0.5%, Cobalt (Co) / Germanium (Ge) 0.1 to 0.3%

3.4. How to Define the Model Suffix (NTSC or PAL model)







There are seven kinds of DMC-G2 (Camera body unit), regardless of the colours.

- a) DMC-G2 (Japan domestic model)
- b) DMC-G2PP
- c) DMC-G2EB/EC/EG/GH/GN
- d) DMC-G2GC
- e) DMC-G2GK
- f) DMC-G2GT
- g) DMC-G2GD

What is the difference is that the "INITIAL SETTINGS" data which is stored in Flash-ROM mounted on MAIN P.C.B..

3.4.1. Defining methods:

To define the model suffix to be serviced, refer to the nameplate which is putted on the bottom side of the Unit.

<p>a) DMC-G2 (Japan domestic model) The nameplate for this model show the following Safety registration mark.</p> 
<p>b) DMC-G2PP The nameplate for this model show the following Safety registration mark.</p> 
<p>c) DMC-G2EB/EC/EG/GH/GN The nameplate for these models show the following Safety registration mark.</p> 
<p>d) DMC-G2GC The nameplate for this model show the following Safety registration mark.</p> 
<p>e) DMC-G2GK The nameplate for this model show the following Safety registration mark.</p> 
<p>f) DMC-G2GT The nameplate for this model show the following Safety registration mark.</p> 
<p>g) DMC-G2GD The nameplate for this model show the following Safety registration mark.</p> 

NOTE:

After replacing the MAIN P.C.B., be sure to achieve adjustment.
Refer to the adjustment instruction in the adjustment software for details.

3.4.2. INITIAL SETTINGS:

After replacing the MAIN P.C.B., be sure to perform the initial settings after achieving the adjustment by ordering the following procedure in accordance with model suffix of the unit.

1. IMPORTANT NOTICE:

Before proceeding Initial settings, be sure to read the following CAUTION.

CAUTION:(INITIAL SETTINGS)

---AFTER REPLACING THE MAIN P.C.B. ---

[Except "EG, EB and EC" models : (VEP56106A is used as a Main P.C.B.)]

*.The model suffix can be chosen **JUST ONE TIME.**
(Effective model suffix : " PP/GC/GD/GH/GK/GN/GT and NONE(JAPAN)")

*.Once one of the model suffix has been chosen, the model suffix lists will not be displayed, thus, it can not be changed.

[Only for "EG, EB and EC" models : (VEP56106B is used as a Main P.C.B.)]

*.From the beginning, only "EG, EB and EC" are displayed as model suffix lists, and these are displayed from the second times as well.

2. PROCEDURES:

- **Precautions:** Read the above "CAUTION" carefully.

- **Preparation:**

Attach the Battery or Battery Charger/AC Adaptor which is connected the DC cable, and insert the SD memory card. Confirmed that it is not intelligent auto mode [iA].

NOTE:

If the unit is intelligent auto mode [iA], it does not display the initial settings menu.

- **Step 1. The temporary cancellation of "INITIAL SETTINGS":**

Set the Drive mode lever to [SINGLE].

While keep pressing [DISPLAY] and [AF/AE LOCK] buttons simultaneously, turn the Power on.

- **Step 2. The cancellation of "INITIAL SETTINGS":**

Press the [PLAYBACK] button, then playback the picture.

Press [AF/AE LOCK] and "[UP] of Cursor buttons" simultaneously, then turn the Power off.

- **Step 3. Turn the Power on:**

Set the mode dial to [P], and then turn the Power on.

- **Step 4. Display the INITIAL SETTING:**

While keep pressing [MENU/SET] and "[RIGHT] of Cursor buttons" simultaneously, turn the Power off.

The "INITIAL SETTINGS" menu is displayed.

There are two kinds of "INITIAL SETTINGS" menu form as follows:

[CASE 1. After replacing MAIN P.C.B.]

[Except "EG, EB and EC" models : (VEP56106A is used as a Main P.C.B.)]

When MAIN P.C.B. has just been replaced, all of the model suffix are displayed as follows. (two pages in total)



[Only for "EG, EB and EC" models : (VEP56106B is used as a Main P.C.B.)]

When MAIN P.C.B. has just been replaced, only 4 model suffix are displayed as follows.

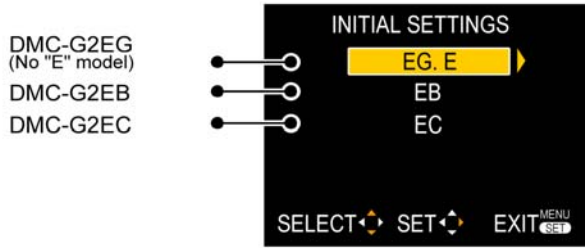

[CASE 2. Other than "After replacing MAIN P.C.B."]



• Step 5. Choose the model suffix in "INITIAL SETTINGS": (Refer to "CAUTION")

[Caution: After replacing MAIN P.C.B.]

The model suffix can be chosen, **JUST ONE TIME**.

Once one of the model suffix have been chosen, the model suffix lists will not be displayed, thus, it can be changed.

Therefore, select the area carefully.

Select the area with pressing "[UP] / [DOWN] of Cursor buttons".

• Step 6. Set the model suffix in "INITIAL SETTINGS":

- Press the "[RIGHT] of Cursor buttons".
- The only set area is displayed, and then press the "[RIGHT] of Cursor buttons" after confirmation.
(The unit is powered off automatically.)

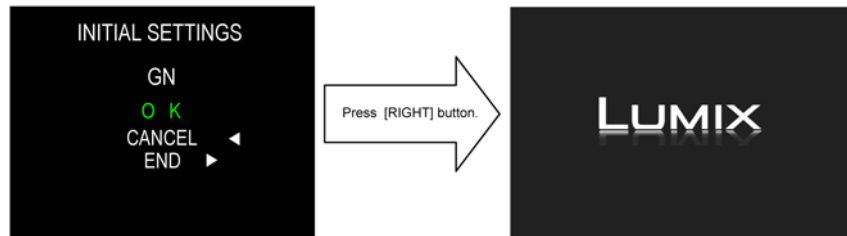

• Step 7. CONFIRMATION:

Confirm the display of "PLEASE SET THE CLOCK" in concerned language when the unit is turned on again.

When the unit is connected to PC with USB cable, it is detected as removable media.

1) As for your reference, major default setting condition is as shown in the following table.

• Default setting (After "INITIAL SETTINGS")

	MODEL	VIDEO OUTPUT	LANGUAGE	DATE	REMARKS
a)	DMC-G2 (Japan domestic model)	NTSC	Japanese	Year/Month/Date	
b)	DMC-G2PP	NTSC	English	Month/Date/Year	
c)	DMC-G2EG	PAL	English	Date/Month/Year	
d)	DMC-G2GC	PAL	English	Date/Month/Year	
e)	DMC-G2GK	PAL	Chinese (simplified)	Year/Month/Date	
f)	DMC-G2EB	PAL	English	Date/Month/Year	
g)	DMC-G2GN	PAL	English	Date/Month/Year	
h)	DMC-G2EC	PAL	English	Date/Month/Year	
i)	DMC-G2GH	PAL	English	Date/Month/Year	
j)	DMC-G2GD	NTSC	Korean	Year/Month/Date	
k)	DMC-G2GT	NTSC	Chinese (traditional)	Year/Month/Date	

4 Specifications

Digital Camera Body (DMC-G2): Information for your safety

Power Source:	DC 9.3 V
Power Consumption:	2.6 W (When recording with LCD Monitor) (When the 14–42 mm/F3.5–5.6 lens included in DMC-G2K/DMC-G2W is used) 2.8 W (When recording with LCD Monitor) (When the 45–200 mm/F4.0–5.6 lens included in DMC-G2W is used) 1.6 W (When playing back with LCD Monitor) (When the 14–42 mm/F3.5–5.6 lens included in DMC-G2K/DMC-G2W is used) 1.8 W (When playing back with LCD Monitor) (When the 45–200 mm/F4.0–5.6 lens included in DMC-G2W is used)

Camera effective pixels:	12,100,000 pixels
Image sensor:	4/3" Live MOS sensor, total pixel number 13,060,000 pixels, Primary colour filter
Digital zoom:	Max. 4x
Extra Optical Zoom: (Except for the maximum picture size for each aspect ratio)	ON/OFF simple enlargement (compatible with lenses from other manufacturers)
Focus:	Auto focus/Manual Focus, Face detection/AF Tracking/23-area-focusing/1-area-focusing (Touch focus area selection possible)
Shutter system:	Focal-plane shutter
Burst recording	
Burst speed:	3.2 pictures/second (High speed), 2.6 pictures/second (Middle speed), 2 pictures/second (Low speed)
Number of recordable pictures:	Max. 7 pictures (when there are RAW files) Depends on the capacity of the card (when there are no RAW files)
ISO sensitivity (Standard Output Sensitivity):	AUTO/[ISO]100/200/400/800/1600/3200/6400 (1/3 EV step change possible)
Shutter speed:	B (Bulb) (max. 4 minutes), 60 seconds to 1/4000th of a second Taking still pictures during motion picture recording: 1/30th of a second to 1/16000th of a second
Metering range:	EV 0 to EV 18
White balance:	Auto white balance/Daylight/Cloudy/Shade/Incandescent lights/Flash/White set1/White set2/White balance K set
Exposure (AE):	Programme AE (P)/Aperture-priority AE (A)/Shutter-priority AE (S)/Manual exposure (M)/AUTO Exposure Compensation (1/3 EV Step, -3 EV to +3 EV)
Metering mode:	Multiple/Centre weighted/Spot
LCD monitor:	3.0" TFT LCD (Approx. 460,000 dots) (field of view ratio about 100%) Touch panel
Viewfinder:	Colour LCD Viewfinder (Approx. 1,440,000 dots) (field of view ratio about 100%) (with diopter adjustment -4 to +4 diopter)
Flash:	Built-in pop up flash GN 11 equivalent (ISO100·m) Flash range: Approx. 45 cm (1.48 feet) to 6.2 m (20.3 feet) (When the 14–42 mm/F3.5–5.6 lens included in DMC-G2K/DMC-G2W is mounted, WIDE, [ISO AUTO] is set) Flash range: Approx. 1.0 m (3.28 feet) to 5.5 m (18.0 feet) (When the 45–200 mm/F4.0–5.6 lens included in DMC-G2W is mounted, WIDE, [ISO AUTO] is set) AUTO, AUTO/Red-eye reduction, Forced ON, Forced ON/Red-eye reduction, Slow sync., Slow sync./Red-eye reduction, Forced OFF
Flash synchronization speed:	Equal to or smaller than 1/160th of a second
Microphone:	Monaural
Speaker:	Monaural
Recording media:	SD Memory Card/SDHC Memory Card/SDXC Memory Card
Picture size	
Still picture:	When the aspect ratio setting is [4:3] 4000×3000 pixels, 2816×2112 pixels, 2048×1536 pixels When the aspect ratio setting is [3:2] 4000×2672 pixels, 2816×1880 pixels, 2048×1360 pixels When the aspect ratio setting is [16:9] 4000×2248 pixels, 2816×1584 pixels, 1920×1080 pixels When the aspect ratio setting is [1:1] 2992×2992 pixels, 2112×2112 pixels, 1504×1504 pixels
Recording quality	
Motion pictures:	[AVCHD Lite] (With audio) [for NTSC areas] When set to [SH]: 1280×720 pixels (50p recording*/Approx. 17 Mbps)/ When set to [H]: 1280×720 pixels (50p recording*/Approx. 13 Mbps)/ When set to [L]: 1280×720 pixels (50p recording*/Approx. 9 Mbps) (* Sensor output is 25 frames/sec.) [for PAL areas] When set to [SH]: 1280×720 pixels (60p recording*/Approx. 17 Mbps)/ When set to [H]: 1280×720 pixels (60p recording*/Approx. 13 Mbps)/ When set to [L]: 1280×720 pixels (60p recording*/Approx. 9 Mbps) (* Sensor output is 30 frames/sec.) [MOTION JPEG] (With audio) When set to [HD]: 1280×720 pixels (30 frames/sec.)/ When set to [WVGA]: 848×480 pixels (30 frames/sec.)/ When set to [VGA]: 640×480 pixels (30 frames/sec.)/ When set to [QVGA]: 320×240 pixels (30 frames/sec.)

Quality:	RAW/RAW+Fine/RAW+Standard/Fine/Standard
Recording file format	
Still Picture:	JPEG (based on "Design rule for Camera File system", based on "Exif 2.21" standard)/DPOF corresponding
Pictures with audio:	JPEG (based on "Design rule for Camera File system", based on "Exif 2.21" standard)+ "QuickTime"
Motion pictures with audio:	AVCHD Lite/QuickTime Motion JPEG
Interface	
Digital:	"USB 2.0" (High Speed)
Analogue video/ audio:	[for NTSC areas] NTSC Audio line output (monaural) [for PAL areas] NTSC/PAL Composite (Switched by menu) Audio line output (monaural)
Terminal	
[MIC/REMOTE]:	φ 2.5 mm jack
[AV OUT/DIGITAL]:	Dedicated jack (8 pin)
[HDMI]:	MiniHDMI TypeC
[DC IN]:	None (when using an AC adaptor, use optional DC cable)
Dimensions:	Approx. 124 mm (W)×83.6 mm (H)×74.0 mm (D) [4.88" (W)×3.29" (H)×2.91" (D)] (excluding the projecting parts)
Mass:	Approx. 593 g/1.31 lb (with the 14–42 mm/F3.5–5.6 lens included in DMC-G2K/DMC-G2W, card and battery) Approx. 810 g/1.79 lb (with the 45–200 mm/F4.0–5.6 lens included in DMC-G2W, card and battery) Approx. 371 g/0.82 lb (camera body)
Operating temperature:	0 °C to 40 °C (32 °F to 104 °F)
Operating humidity:	10% to 80%

AC Adaptor: Information for your safety

Input:	110 V to 240 V ~ 50/60 Hz, 0.3 A
Output:	9.3 V --- 1.2 A (Unit operation) 8.4 V --- 0.65 A (Battery charging)

Battery Pack (lithium-ion): Information for your safety

Voltage/capacity :	7.2 V/1250 mAh
---------------------------	----------------

Interchangeable Lens (H-FS014042) "LUMIX G VARIO 14–42 mm/F3.5–5.6 ASPH./MEGA O.I.S."	
Focal length:	f=14 mm to 42 mm (35 mm film camera equivalent: 28 mm to 84 mm)
Aperture type:	7 leaf shutters/iris diaphragm/circular diaphragm
Aperture range:	F3.5 (Wide) to F5.6 (Tele)
Minimum aperture value:	F22
Lens construction:	12 elements in 9 groups (1 non-spherical lenses)
In focus distance:	0.3 m (0.99 feet) to ∞ (from the focus distance reference line)
Maximum image magnification:	0.16× (35 mm film camera equivalent: 0.32×)
Optical Image Stabilizer:	Available
[O.I.S.] switch:	None (Setting of the [STABILIZER] is done in [REC] mode menu.)
Mount:	"Micro Four Thirds Mount"
Angle of view:	75° (Wide) to 29° (Tele)
Filter diameter:	52 mm (2.05 inch)
Max. diameter:	Approx. 60.6 mm (2.39 inch)
Overall length:	Approx. 63.6 mm (2.50 inch) (from the tip of the lens to the base side of the lens mount)
Mass:	Approx. 165 g/0.22 lb

Interchangeable Lens (H-FS045200) "LUMIX G VARIO 45–200 mm/F4.0–5.6/MEGA O.I.S."	
Focal length:	f=45 mm to 200 mm (35 mm film camera equivalent: 90 mm to 400 mm)
Aperture type:	7 leaf shutters/iris diaphragm/circular diaphragm
Aperture range:	F4.0 (Wide) to F5.6 (Tele)
Minimum aperture value:	F22
Lens construction:	16 elements in 13 groups (no aspherical lens)
In focus distance:	1.0 m (3.28 feet) to ∞ (from the focus distance reference line)
Maximum image magnification:	0.19× (35 mm film camera equivalent: 0.38×)
Optical Image Stabilizer:	Available
[O.I.S.] switch:	Available (Switching ON/OFF)
Mount:	"Micro Four Thirds Mount"
Angle of view:	27° (Wide) to 6.2° (Tele)
Filter diameter:	52 mm (2.05 inch)
Max. diameter:	Approx. 70 mm (2.76 inch)
Overall length:	Approx. 100 mm (3.94 inch) (from the tip of the lens to the base side of the lens mount)
Mass:	Approx. 380 g/0.84 lb

NOTE:(Only for "EB/EC/EG" models)

- Data from the PC can not be written to the camera using the USB connection cable.
- Motion pictures can be recorded continuously for up to 29 minutes 59 seconds.

5 Location of Controls and Components

Names of the Components

■ Camera body

- 1 Flash
- 2 Sensor
- 3 Self-timer indicator
AF Assist Lamp
- 4 Lens release button
- 5 Lens lock pin
- 6 Mount
- 7 Lens fitting mark

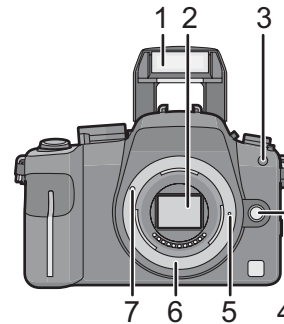

- 8 [LVF/LCD] button
- 9 Diopter adjustment dial
- 10 Viewfinder
- 11 Eye sensor
- 12 Playback button
- 13 [AF/AE LOCK] button
- 14 Camera ON/OFF switch
- 15 Rear dial

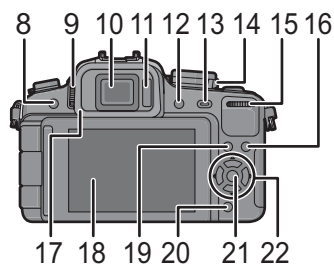

- 16 [DISPLAY] button
 - 17 Eye Cup
 - 18 Touch panel/LCD monitor
 - 19 [Q.MENU] button
 - 20 Delete button/
Preview button/
Flicker Reduction Function
 - 21 [MENU/SET] button
 - 22 Cursor buttons
 - ▲/ISO
 - ◀/Film Mode
 - ▼/Function button
- Assign Menu to ▼ button. It is convenient to register a Menu that is used often.
 [FOCUS AREA SET]/[ASPECT RATIO]/[QUALITY]/[METERING MODE]/
 [I.RESOLUTION]/[I.EXPOSURE]/[EX. OPT. ZOOM]/[GUIDE LINE]/[REC AREA]/
 [REMAINING DISP.]
 ▶/WB (White Balance)

- 23 Focus mode lever
- 24 Auto focus mode dial
Face Detection ([]): []
AF Tracking ([]): []
23-area-focusing ([]): []
1-area-focusing ([]): []
- 25 Microphone
- 26 Drive mode lever
Single: []
Burst: []
Auto Bracket: []
Self-timer: []
- 27 Shutter button
- 28 Focus distance reference mark
- 29 Flash open lever
- 30 Hot shoe
- 31 Mode dial
- 32 Status indicator
- 33 Motion picture button
- 34 Intelligent Auto button
- 35 [MIC/REMOTE] socket
- 36 Shoulder strap eyelet
• Be sure to attach the shoulder strap when using the camera to ensure that you will not drop it.
- 37 [HDMI] socket
- 38 [AV OUT/DIGITAL] socket

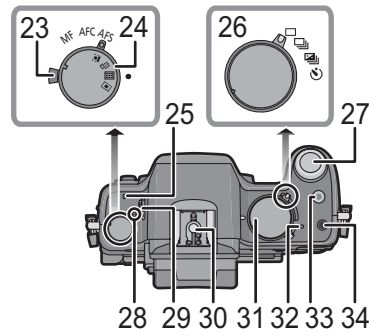

- 39 DC cable cover

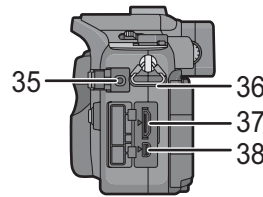

- 40 Card/Battery door
- 41 Release lever
- 42 Tripod receptacle
• When you use a tripod, make sure the tripod is stable when the camera is attached to it.

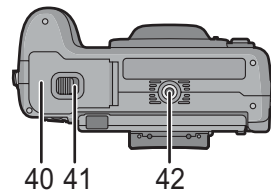
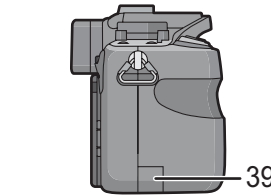

■ Lens

H-FS014042 (LUMIX G VARIO 14–42 mm/F3.5–5.6 ASPH./MEGA O.I.S.)

- 43 Tele
- 44 Lens surface
- 45 Focus ring
- 46 Wide
- 47 Zoom ring
- 48 Contact point
- 49 Lens fitting mark

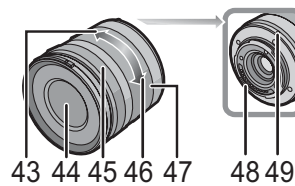

H-FS045200 (LUMIX G VARIO 45–200 mm/F4.0–5.6/MEGA O.I.S.)

- 50 Tele
- 51 Lens surface
- 52 Focus ring
- 53 [O.I.S.] switch
- 54 Wide
- 55 Zoom ring
- 56 Contact point
- 57 Lens fitting mark

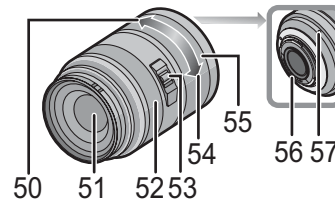

■ Battery charger/AC adaptor

- 58 Power input socket [AC IN]
- 59 [CHARGE] indicator
- 60 Power output socket [DC OUT]
- 61 Battery holder

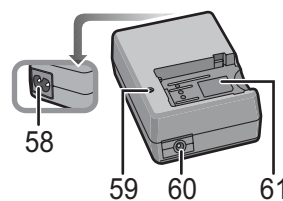

Selecting the [REC] Mode, and Recording Still Pictures or Motion Pictures

■ To select Intelligent Auto Mode

Press [iA] (A).

- [iA] button will light up when it is switched to Intelligent Auto Mode.

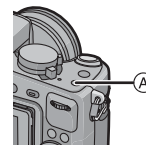

iA Intelligent Auto Mode

The subjects are recorded using settings automatically selected by the camera.

■ To select a [REC] Mode with the mode dial

Switching the mode by rotating the mode dial.

Align a desired mode with part (B).

- Rotate the mode dial slowly to adjust to each mode. (The mode dial rotates 360 °)
- The Recording Mode selected by the mode dial is disabled while the [iA] button is lit.

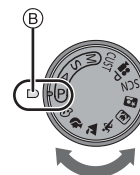

■ List of [REC] Modes

P Program AE Mode

The subjects are recorded using your own settings.

A Aperture-Priority AE Mode

The shutter speed is automatically determined by the aperture value you set.

S Shutter-Priority AE Mode

The aperture value is automatically determined by the shutter speed you set.

M Manual Exposure Mode

The exposure is adjusted by the aperture value and the shutter speed which are manually adjusted.

CUST Custom Mode

Use this mode to take pictures with previously registered settings.

Motion Picture P Motion Picture P Mode

Use this mode to record motion pictures with the desired settings.

SCN Scene Mode

This allows you to take pictures that match the scene being recorded.

My Color My Color Mode

Use this mode to check coloring effects, select a Color Mode from among eight Color Modes, and then take pictures.

■ Advanced Scene Mode

Portrait Portrait Mode

Use this mode to take pictures of people.

Scenery Scenery Mode

Use this mode to take pictures of scenery.

Sports Sports Mode

Use this mode to take pictures of sporting events, etc.

Close-up Close-up Mode

Use this mode to take pictures of a close-by subject.

Night portrait Night portrait Mode

Use this mode to take pictures of night scenes and people against night time scenery.

How to Use the Touch Panel

You can operate by directly touching the LCD monitor (touch panel) with your finger.

■ Touch

To touch and release the touch panel.

It is used to select an icon or picture.

- It may not operate properly when multiple icons are touched simultaneously, so try to touch the center of the icon.

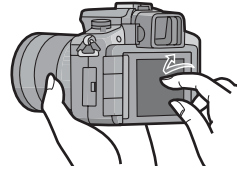

■ Drag

A movement without releasing the touch panel.

It is used to change the range of displayed pictures, or switch the screen with the slide bar.

- If you select a wrong icon, you can drag to a different icon, and that icon will be selected by releasing your finger.

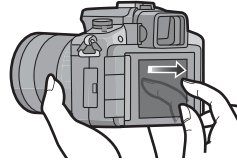

📌 Note

- The touch panel does not operate when the LCD monitor is turned off.
- This touch panel is a type that detects pressure. **Touch a little stronger** if you have a commercially available protection sheet affixed.
- If you use a commercially available liquid crystal protection sheet, please follow the instructions that accompany the sheet. (Some liquid crystal protection sheets may impair visibility or operability.)
- Touch panel will not operate if the hand holding the unit is touching the touch panel.
- Do not press on the LCD monitor with hard pointed tips, such as ball point pens.
- Do not operate with your fingernails.
- Wipe the LCD monitor with a dry soft cloth when it gets dirty with finger prints or other.
- Do not scratch or press the LCD monitor too hard.

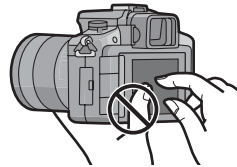

About the Stylus pen





It is easier to use the stylus pen (supplied) for detailed operation or if it is hard to operate with your fingers.

- Only use the supplied stylus pen.
- Do not place it where small children can reach.

What can be done by touch operation

By using the touch panel, you can move the AF area by touching the subject to focus on, or change the setting directly by touching the icons, making it easier to operate during recording or setting.

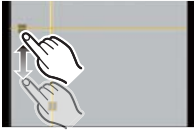
Following are examples of what can be done by touch operation.

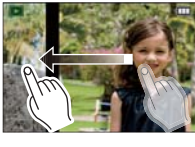
When recording		
 <p>Touch Tracking Touch 1-area AF Face Recognition Touch 1-area AF Touch Multi AF Area Selection Touch MF Assist Enlarge</p>	 <p>Touch Shutter During recording, a picture is taken automatically after focusing on the subject that is touched.</p>	 <p>Guide Line Position Movement Histogram Position Movement</p>
When recording	When playing back	
 <p>Touch Quick Menu LCD Recording Information Display Touch Operation</p>	 <p>Picture Playback Playback Zoom</p>	

Note

- When the guide as shown on the right is displayed on the screen, it is also possible to operate using ▲/▼/◀/▶ of the cursor button and [MENU/SET] button.
 ▲/▼/◀/▶: Selection of items or setting of values etc. is performed.
 [MENU/SET]: Confirmation of setting contents or exit from menu is performed.
- Menu item cannot be set with touch operation. Set with the cursor button or rear dial.
- Touch operation is not possible while using the viewfinder. Perform the setting using the cursor button or rear dial.



About the Battery

- The camera has a function for distinguishing batteries which can be used safely. The dedicated battery supports this function. The only batteries suitable for use with this unit are genuine Panasonic products and batteries manufactured by other companies and certified by Panasonic. (Batteries which do not support this function cannot be used). Panasonic cannot in any way guarantee the quality, performance or safety of batteries which have been manufactured by other companies and are not genuine Panasonic products.

It has been found that counterfeit battery packs which look very similar to the genuine product are made available to purchase in some markets. Some of these battery packs are not adequately protected with internal protection to meet the requirements of appropriate safety standards. There is a possibility that these battery packs may lead to fire or explosion. Please be advised that we are not liable for any accident or failure occurring as a result of use of a counterfeit battery pack. To ensure that safe products are used we would recommend that a genuine Panasonic battery pack is used.

6 Service Mode

6.1. Error Code Memory Function

1. General description

This unit is equipped with history of error code memory function, and can be memorized 16 error codes in sequence from the latest. When the error is occurred more than 16, the oldest error is overwritten in sequence.

The error code is not memorized when the power supply is shut down forcibly.

(i.e., when the unit is powered on by the battery, the battery is pulled out)

The error code is memorized to FLASH-ROM when the unit has just before powered off.

2. How to display

The error code can be displayed by ordering the following procedure:

• Preparation

Attach the Battery or Battery Charger/AC Adaptor which is connected the DC Cable, and insert the SD memory card.

Confirmed that it is not intelligent auto mode [iA].

NOTE:

If the unit is intelligent auto mode [iA], it does not display the error code display.

• Step 1. The temporary cancellation of "INITIAL SETTINGS":

Set the Drive mode lever to [SINGLE].

While keep pressing [DISPLAY] and [AF/AE LOCK] buttons simultaneously, turn the Power on.

• Step 2. Execute the error code display mode:

Press [AF/AE LOCK], [MENU/SET] and "[LEFT] of Cursor buttons" simultaneously with the step 1 condition.

The display is changed as shown below when the above buttons are pressed simultaneously.

Normal display → Error code display → Camera information display → Normal display →

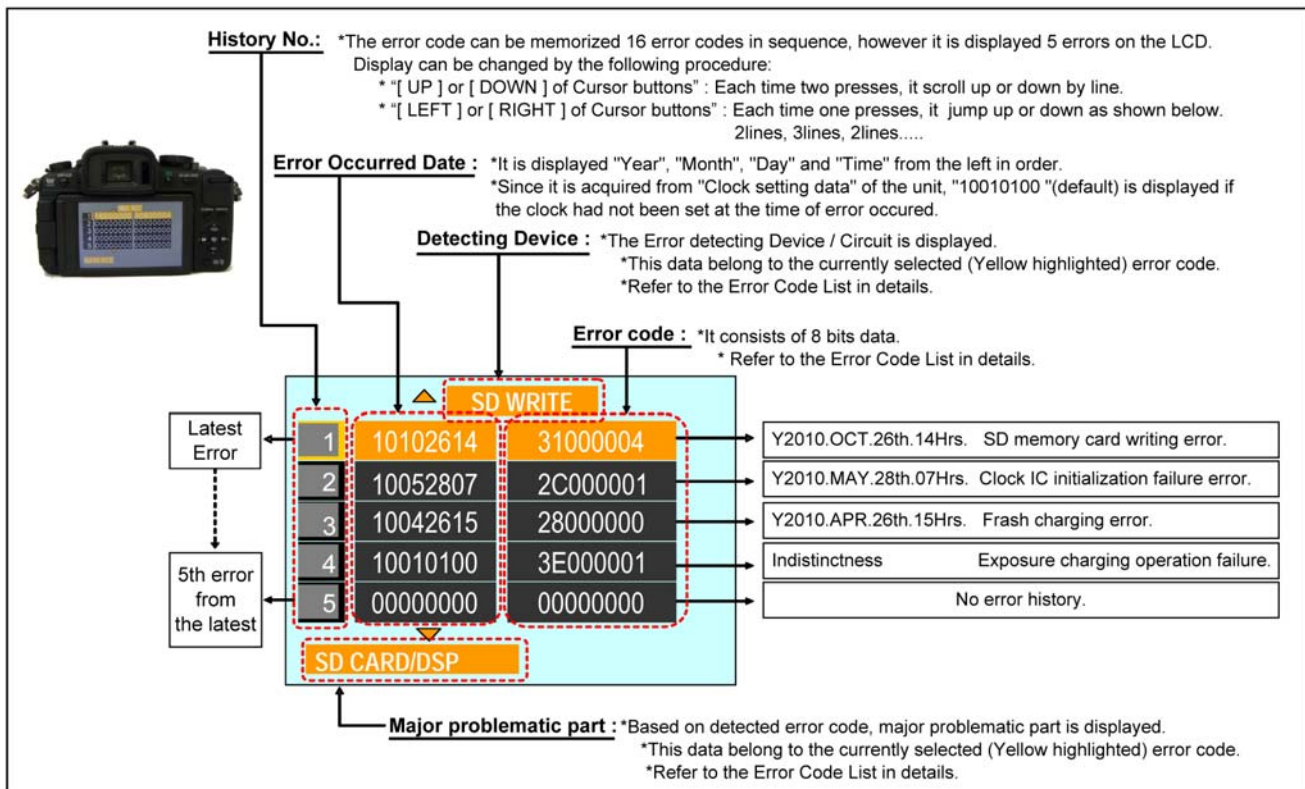

Example of Error Code Display

• **Error Code List:**

The error code consists of 8 bit data and it shows the following information.

Attribute	Main item	Sub item	Error code		Contents (Upper line)	Error Indication	
			High 4 bits	Low 4 bits		Detecting device	Problematic Part/Circuit
HARD	VENUS A/D	Flash	28*0	0000	Flash charging capacitor did not been fully charged within 20 seconds.	STRB CHG	STRB PCB/FPC
	FLASH ROM	Data Area	2B*0	0001	Flash ROM data reading error is detected when the unit turns ON.	FROM RE	FROM
				0002	Flash ROM data writing error is detected when the unit turns OFF.	FROM WR	FROM
		Program Area		0005	Firmware update error.	(No indication)	(No indication)
	SYSTEM IC	Initialization	2C*0	0001	Clock IC initialization failure error.	SYS INIT	MAIN PCB
SOFT	CPU	Reset	30*0	0001	System error (NMI reset).	NMI RST	MAIN PCB
				0007			
	Recording Media	SD Memory Card	31*0	0001	SD memory card logic error. SD memory card format error. When it is detected, [MEMORY CARD ERROR FORMAT THIS CARD?] is displayed on the screen.	SD CARD	SD CARD/DSP
				0002	SD memory card physical error. During formatting the SD memory card, there is no response from the card. If the mini-SD memory card is used, check the SD memory card adaptor.		SD CARD/DSP
				0004	SD memory card writing error. Check the SD memory card. It might be damage one.	SD WRITE	SD CARD/DSP
	Lens	Communication	3C*0	0001 000E	Lens communication error.	(No indication)	(No indication)
	Camera	System	3B*0 3E*0	0000	Initialization failure error.	INIT	(No indication)
				0001	Exposure charging operation failure. (Mount Box Unit)		
				0002	Failure of the returning operation to the home position. (Mount Box Unit)		
Recording	Motion Image Recording	3F*0	0001	File time out error in recording motion image.	(No indication)	(No indication)	
			0002	File data cue send error in recording motion image.			

Important notice about “Error Code List”

About "*" indication:

The third digit from the left is different as follows.

- In case of 0 (example: 2B001000)

When the third digit from the left shows “0”, this error occurred under the condition of INITIAL SETTINGS has been completed.

It means that this error is occurred basically at user side.

- In case of 8 (example: 2B801000)

When the third digit from the left shows "8", this error occurred under the condition of INITIAL SETTINGS has been released.

(Example; Factory assembling-line before unit shipment, Service mode etc.)

It means that this error is occurred at service side.

• **Step 3. How to exit from Error Code display mode:**

Simply, turn the power off. (Since Error Code display mode is executed under the condition of temporary cancellation of “INITIAL SETTINGS”, it wake up with normal condition when turn off the power.)

NOTE:

The error code can not be initialized.

7 Troubleshooting Guide

7.1. Checking Method of Body and Interchangeable Lens

1. INITIAL (DEFAULT) STATUS OF THE LENS UNIT

The Lens unit which is supplied as a standard accessory for this camera unit (H-FS014042, H-FS045200) shows the following status when the Lens is detached from the Camera unit.

NOTE: Although the lens unit is attached it shows the same condition when the Camera turns off.

H-FS014042 (Included in DMC-G2K and DMC-G2W):

- [1]. ZOOM RING When the Zoom ring is rotated, Zoom condition is changing accordingly.
(The 1st lens frame moves.)
[Focal length : 14mm to 42mm [35mm film camera equivalent: 28mm to 84mm]]
- [2]. FOCUS RING The Focus condition does not change although Focus ring is rotated. (Free rotation.)

H-FS045200 (Included in DMC-G2W):

- [1]. ZOOM RING When the Zoom ring is rotated, Zoom condition is changing accordingly.
(The 1st lens frame moves.)
[Focal length : 45mm to 200mm [35mm film camera equivalent: 90mm to 400mm]]
- [2]. FOCUS RING The Focus condition does not change although Focus ring is rotated. (Free rotation.)

2. INITIAL INSPECTION TIPS (BEFORE DETERMINE THE UNIT BEING FAULTY/DEFECTIVE):

Since this unit is equipped with various functions/settings, some phenomenon/effect might be caused by miss usage of function and/or settings.

It might be made a miss-judgement caused by miss usage of function & settings although the unit is working properly without fault.

Therefore, check/confirm the followings before concluding/determine the unit being faulty/defective.





NOTE: Refer to the Operating Instructions carefully.

Also, useful hint/tips for this unit is available at following URL, and is updated frequently.



<http://panasonic.jp/support/global/cs/dsc/>

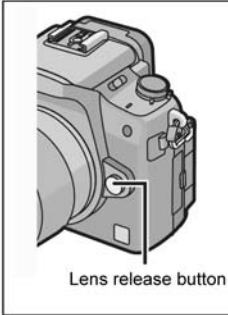

If it is hard to determine whether the resolution is out of specification or not, proceed the "RESOLUTION INSPECTION", before replacing the LENS MAIN BLOCK UNIT and/or MOUNT BOX UNIT. (The unit might be mishandling, dropping or others.)

[1]. [LENS RELATIVES]

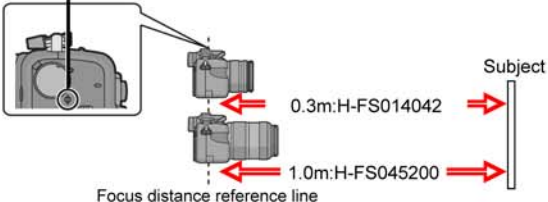
TITLE	ITEMS	DESCRIPTION
LENS	Aperture size does not changed. (Although aperture value is changed, the physical size of aperture is never changed.)	*Although aperture value is changed, the physical size of aperture is never changed (It keeps the maximum aperture condition) until the shutter release button is fully released. (There is no "aperture stopping down" button and/or function. But instead, there is a shutter speed preview mode.) ⇒ [CUSTOM MENU] (3/7) ----- [PREVIEW HOLD] (ON/OFF)
	The Aperture condition does not changed. (Aperture value shows "A0.0")	*The Lens & Body are communicating (serial communication) through mount contacts (11 pins). *Confirm that lens & body mount contacts are not dirty. *While keep pressing the [Lens release] button, it makes same situation that Lens does not attached. *Although lens is attached to the body, the Aperture value shows "A0.0" when the communication error is occurred. Also, when the firmware version confirmation mode is executed, the [- -] is displayed as Lens firmware version.  Aperture value is fixed at [A0.0]  Firmware version shows [LENS FIRMWARE : - -]  Lens release button
	Although the Focus ring is rotating, it does not change the Focus condition.	*The Focus condition is never changed although focus ring is rotated when the Focus mode dial is positioned at AFS or AFC. (When the [AF + MF] is set to [ON], it is able to fine adjust the focus manually by rotating the focus ring while AF lock.) ⇒ [CUSTOM MENU] (3/7) ----- [AF + MF] (ON/OFF)
	No released without lens attachment.	*It is able to release the shutter button without attaching the lens unit. ⇒ [CUSTOM MENU] (7/7) ----- [SHOOT W/O LENS] (ON/OFF)
	The Dusty and/or dirty of the Lens	*Define the location of the dirt / dust of the lens first, whether it is outside surface of the lens or not. If it is outside surface of the lens, order the following procedure in steps. STEP-1. Blow off the dust certainly with Hand Blower. STEP-2. Clean and wipe up the Lens surface by using the Lens cleaning Kit (VFK1900BK). *Refer to the "11 Maintenance" of this manual.  [Wiping up the lens surface] Like drawing the circle, wipe up the lens surface centre towards to outside slowly.
It does not become the Shutter speed [B] (Bulb) mode.	*It is only able to select the shutter speed to [B](Bulb) when mode dial is set to [M] (Manual) and drive mode lever is [SINGLE] position. ([B] mode: the shutter stays open while the shutter button is pressed fully (up to about 4 minutes). The shutter closes if you release the shutter button.)	

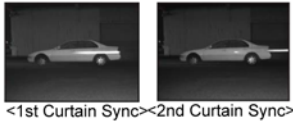

[2]. [BODY RELATIVES]

TITLE	ITEMS	DESCRIPTION
FOCUS	The picture is out of focus although the focus is adjusted in MF mode at once.	<ul style="list-style-type: none"> *In the following conditions, the focus may be out of focus, no matter the kind of subject. Therefore, adjust the focus again by rotating the Focus ring. *After "in-focus" condition, Zoom condition has been changed. *Power switch is turned OFF and ON again. *After releasing the Power save.
	Focus does not become in focus condition.	<ul style="list-style-type: none"> *If the shooting distance is less than the Minimum requirement distance for focus, the focus may not be brought into focus, no matter the kind of subject. <p>Focus distance reference mark</p> 
	MF(Manual Focus)ASSIST does not work.	<ul style="list-style-type: none"> *The MF assist function is that the certain area image is able to enlarge 5 times to make easier to focus. (It is enlarged from 5times to 10 times when the front dial is rotated clockwise.) *It does not activated if the [Focus Mode Dial] is positioned other than [MF] position. *It does not activated when using the Digital Zoom. *It does not activated if [MF ASSIST] is set to OFF. ⇒ [CUSTOM MENU] (3/7) ----- [MF ASSIST] (ON/OFF) (To display the MF assist, press Left cursor button then press [MENU/SET].)
	Face detection does not work.	<ul style="list-style-type: none"> *Select AF mode to face detection. (In [IA]mode, it is automatically assigned according with scene.) (Press the left side cursor button to display the AF mode menu.) *It does not activated when using the Digital Zoom. *It does not activated if the focus mode dial set to MF.
	The subject is not focused properly.	<ul style="list-style-type: none"> *When get a fingerprint, dirt on the lens surface, resulting in the subject being out of focus. *The subject is beyond the focus range of the camera. *There is camera shake (jitter) or the subject is moving slightly. *The focus indication green mark is lights at the top right hand corner on the LCD when the subject is focused. *The shutter speed will become slower and the optical image stabilizer function may not work properly when taking pictures especially in dark places.
	Focus does not change.	<ul style="list-style-type: none"> *Focus & Exposure condition is locked when the [AF / AE LOCK] button is pressed under the condition of [AF/AE LOCK HOLD] is "On". ⇒ [CUSTOM MENU] (2/7) ----- [AF/AE LOCK HOLD] (ON/OFF) *It can be reset when [AF / AE LOCK] button is pressed again.
	Although [AF/AE LOCK] button is pressed, it does not hold the Focus, only Exposure is locked.	<ul style="list-style-type: none"> *Focus does not hold even if [AF/AE LOCK] button is pressed if the [AF/AE LOCK] is selected [AE]. ⇒ [CUSTOM MENU] (2/7) ----- [AF/AE LOCK] (AE, AF, AF/AE) *In the Manual Focus condition, It is only worked as [AE lock] function.
	It does not turn to the "AFC" mode. (Motion prediction does not work.)	<ul style="list-style-type: none"> *Confirm the setting position of the focus mode dial (AFS / AFC / MF). *Although AFC is effective with burst mode, the focus is fixed on the first picture when subject is dark.
Flash	GN (Guide Number) of the Built in Flash (Specification GN6.0)	<ul style="list-style-type: none"> *By referring the specification of the built-in flash is GN11 (equivalent) *There is a formula : F value X Flash reachable distance = GN [ISO100] (In case of: H-FS045200) ISO100 / Wide edge Aperture is F4.0 / Flash reachable distance is 2.7m [4.0 X Approx 2.7 = 10.8 ----- "GN11"] ISO100 / Tele edge Aperture is F5.6 / Flash reachable distance is 1.9m [5.6 X Approx 1.9 = 10.64 ----- "GN11"]
	Some of the Flash setting(s) are not able to select.	<ul style="list-style-type: none"> *In accordance with the [REC] mode and [FLASH SYNCHRO] mode, selectable flash settings may be differ.
	[AUTO BRACKET] does not work.	<ul style="list-style-type: none"> *Only one picture can be taken when the Flash is fired.
	The subject is too bright / too dark with Flash.	<ul style="list-style-type: none"> *Confirm that the picture is taken within Flash range or not. *Confirm that flash output settings. ⇒ [REC] (2/5) ----- [FLASH ADJUST.] (1/3 EV Step, -2EV to +2EV)
	The Flash adjustment does not effect.	<ul style="list-style-type: none"> *Confirm that the picture is taken within Flash range or not.
White round spots appear on the recording picture	<ul style="list-style-type: none"> *If you take a picture with flash in a dark place or indoors, white round spots may be appear on the picture caused by the flash reflecting of particles of dust in air. This is not a malfunction. *A characteristic of this is that the number of round spots and their position differ in every picture. 	

TITLE	ITEMS	DESCRIPTION
Flash	Colour is strange when the Flash is fired.	<p>*The colour of the subject which is other than Flash reachable distance is not coverage of white balance.</p> <p>*Confirm that [WB Adjustment] setting condition. (Press the cursor [RIGHT] (WB) button, then press the cursor [DOWN] button, in order to execute the [WB ADJUST.] screen.</p> <p>*It also effects to the Flash recording mode as well.</p> 
	The appearance of the light source is strange. (The light source appears ahead the subject.)	<p>*Normally, the light source appears ahead the subject. (This is the effect of the 1st curtain synchro.)</p> <p>*The Flash synchro mode can be selected. ⇒ [REC] (2/5) ----- [FLASH SYNCHRO] (1ST / 2ND)</p> 
EXPOSURE	The Exposure condition can not be changed	<p>*Focus & Exposure condition is locked when the [AF/AE LOCK] button is pressed under the condition of [AF / AE LOCK HOLD] is "On". ⇒ [CUSTOM MENU] (2/7) ----- [AF / AE LOCK HOLD] (ON/OFF)</p> <p>*It can be reset when [AF/AE LOCK] button is pressed again.</p>
	Although [AF/AE LOCK] button is pressed, only focus is locked. (AE is not locked)	<p>*Focus does not hold even if [AF/AE LOCK] button is pressed if the [AF/AE LOCK] is set to [AF]. ⇒ [CUSTOM MENU] (2/7) ----- [AF/AE LOCK] (AE, AF, AF/AE)</p> <p>*In the Manual Focus condition, It is only worked as [AE lock] function, regardless any settings.</p>
	The pictures recorded with [AUTO BRACKET] function are too dark/bright.	<p>*The [AUTO BRACKET] is selected after setting the [EXPOSURE COMPENSATION], the compensated value is effected for its reference value.</p>
	The Exposure condition is changed extremely.	<p>*Spot metering mode is measuring only the limited narrow area on the centre of the screen.</p> <p>*Confirm the setting condition of [EXPOSURE COMPENSATION] (1/3 EV Step, -3EV to +3EV)</p>
CAPTURING	Although shutter is released, no picture is captured.	<p>*Although the shutter button is fully pressed, it can not take a picture until the subject is not focused. (It is able to take a picture when the Focus Priority turns [OFF] although focus condition does not perfect.) OFF is gives priority to the best time to take a picture.</p> <p>*A picture is not taken until the subject is brought into focus, because [FOCUS PRIORITY] is fixed to [ON] in Intelligent Auto Mode. ⇒ [CUSTOM MENU] (2/7) ----- [FOCUS PRIORITY] (ON/OFF)</p>
	[AUTO BRACKET] does not work.	<p>*Only single picture is able to captured when flash is fired.</p> <p>*It can not be used in My colour mode.</p> <p>*The exposure may not be compensated with auto bracket depending on the brightness of the subject.</p>
COLOUR REPRODUCTION	Colour is strange.	<p>*There is a possibility that [Finely adjusting the white balance] is selected/shifted.</p> <p>*Confirm that [WB Adjustment] setting condition. (Press the cursor [RIGHT] (WB) button, then after choosing the WB mode press the cursor [DOWN] button, in order to execute the [WB ADJUST.] screen.)</p> <p>*It is resumed/memorized although power turns off/on.</p> <p>*Confirm that Film mode, especially, [MY FILM1 & 2] settings.</p> 
	Colour is strange. (With Flash)	<p>*The flash light does not reach enough to the subject due to the over than flash reachable distance. In this case, white balance may be other than its coverage.</p>
	The colour is strange (On PC monitor/ Printout image.)	<p>*There is a possibility that the picture is captured with [AdobeRGB] setting. ⇒ [REC] (5/5) ----- [COLOR SPACE] (sRGB/AdobeRGB)</p> <p>*To proceed proper colour reproduction for AdobeRGB, the AdobeRGB capable PC and Printer are necessary.</p> <p>*In accordance with PC environment, it may not be displayed properly when the picture is re-sized with business software.</p>
POWER	The Power is turned off.	<p>*Confirm that the setting condition of [SLEEP]. (If the camera has not been used for the time selected on the setting, the power turns off automatically.) ⇒ [SETUP] (2/5) ----- [ECONOMY] [SLEEP] (OFF/1MIN./2 MIN./5 MIN./10 MIN.)</p>
DISPLAY	Abnormal Picture Effect. Certain part of the picture is flashing in Black & White.	<p>*Confirm that the setting condition of [HIGHLIGHT]. ⇒ [CUSTOM MENU] (1/7) ----- [HIGH LIGHT] (ON/OFF)</p> <p>The white saturated areas appear blinking in Black and White.</p>
	Firmware version	<p>*Confirm that the firmware versions of the body and lens to be checked. ⇒ [SETUP] (4/5) ----- [VERSION DISP.]</p>

MENU LIST (Quick Reference)

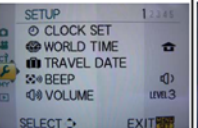
The following menu items are displayed on the LCD monitor.

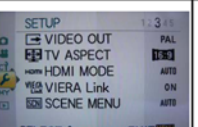
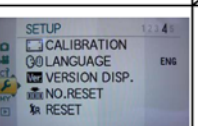
	 [REC]	 [MOTION PICTURE]	 [CUSTOM MENU]	 [SETUP]	 [MY MENU]	 [PLAYBACK]
1st Page						
2nd Page					/	
3rd Page		/			/	
4th Page		/			/	/
5th Page		/			/	/
6th Page	/	/		/	/	/
7th Page	/	/		/	/	/

REMARKS:

*When the [Intelligent Auto Mode], as for [REC], [MOTION PICTURE], [CUSTOM MENU] and [SETUP], only the basic item is displayed.

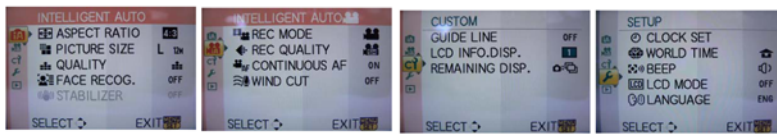

*When the mode dial is set to [Motion Picture P mode], [PLAYBACK] alone is not displayed.

*When the mode dial is set to [Custom mode(CUST)], extra-menu group is displayed.

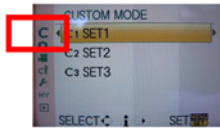

*When the mode dial is set to [Scene mode(SCN)], extra-menu groups are displayed.

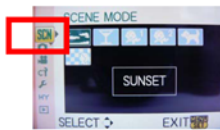

*When the mode dial is set to [Advanced Scene Mode]], extra-menu groups are displayed.

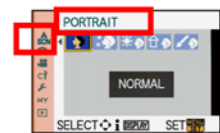

[Portrait Mode]

[Scenery Mode]

[Sports Mode]

[Close-up Mode]

[Night portrait Mode]



*When the mode dial is set to [My Color Mode], [My Color Mode] alone is not displayed.

NOTE:









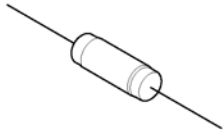
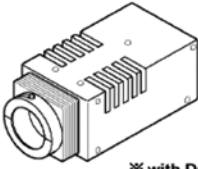
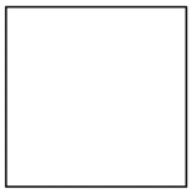

*When set [MENU RESUME] in the [CUSTOM MENU] menu to [ON], the screen shows the last selected menu item when the camera is turned off.

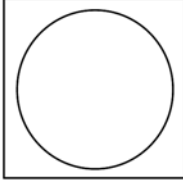
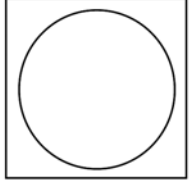
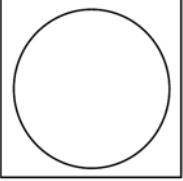
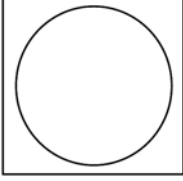
⇒ [CUSTOM MENU] (7/7) ----- [MENU RESUME] (ON/OFF)

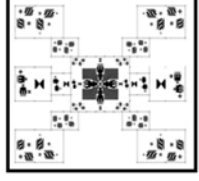
8 Service Fixture & Tools

8.1. Service Fixture and Tools

The following Service Fixture and tools are used for checking and servicing this unit.

Resistor for Discharging ERG5SJ102  An equivalent type of Resistor may be used.	LIGHT BOX VFK1164TDVLB  ※ with DC Cable RFKZ0523 can be used.	ND FILTER 1 VFK1164ND09 
ND FILTER 2 RFKZ0513 	CC FILTER 1 RFKZ0511 	CC FILTER 2 RFKZ0512 
LB FILTER 1 RFKZ0520 	LB FILTER 2 RFKZ0521 	GLAY CARD RFKZ0506 
RESOLUTION CHART RFKZ0510  ※Supplied as divided chart parts. (Assemble it before use.)	DRIVER VFK1390 	TORQUE DRIVER RFKZ0456  Spec.:2-30cN・m (Equiv.0.2-3kgf/cm)
DMC-G1K Standard model  *Correspond by the marketed commodity. (It does not supply as service fixture and tools.)	Lens Cleaning Kit (BK) VFK1900BK  * Only supplied as 10 set/box.	NAME RING FIXTURE RFKZ0507 
STYLUS PEN VGQ0C14  VYQ4370 can be used.		

8.2. Clean Box

- The repair quality is considered, and it is recommended working in the environment of satisfied clean level less than class 10,000 (Federal Standard 209D).

(When remove the 1st lens frame, it is indispensable.)

[NOTE]

- Work in the environment of satisfied clean level less than class 10,000 (Federal Standard 209D) when remove the 1st lens frame for cleaning.

*Refer to "11.2. General description (Lens cleaning: Interchangable Lens/H-FS014042)", "11.3. General description (Lens cleaning: Interchangable Lens/H-FS045200)" section of this service manual for details.

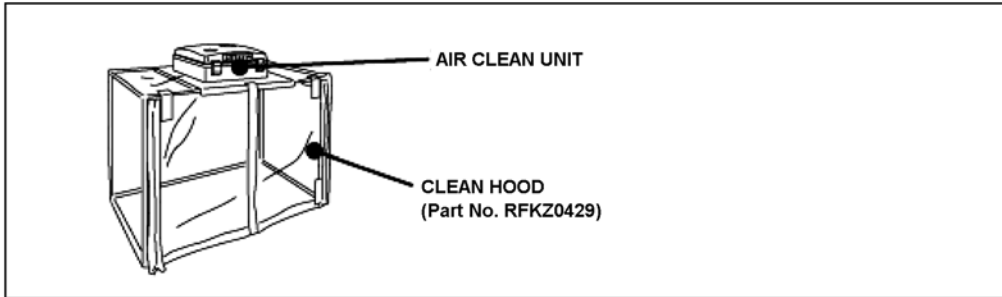

8.3. Service Position

This Service Position is used for checking and replacing parts. Use the following Extension cables for servicing.

Table S1 Extension Cable List

No.	Parts No.	Connection	From
1	VFK1175	FP9001(MAIN) - REAR OPERATION UNIT	16PIN 0.5FFC
2	VFK1364	FP9002(MAIN) - MOUNT BOX UNIT(SHUTTER)	14PIN 0.5FFC
3	VFK1284	FP9003(MAIN) - TOP CASE (R) UNIT(HOT SHOE FPC)	24PIN 0.5FFC
4	RFKZ0477	FP9004(MAIN) - LVF UNIT	45PIN 0.3FFC
5	VFK1175	FP9007(MAIN) - TOP OPERATION (L) UNIT	16PIN 0.5FFC
6	RFKZ0393	FP9009(MAIN) - FP7350(REMOTE)	15PIN to 10PIN 0.3FFC
7	VFK2024	FP9010(MAIN) - FP1001(POW FLASH)	51PIN 0.3FFC
8	VFK1480	FP9011(MAIN) - OPTICAL SENSOR UNIT	6PIN 0.5FFC
9	VFK1951	FP9090(MAIN) - LCD UNIT	39PIN 0.3FFC
10	RFKZ0477	FP3901(MAIN) - MOUNT BOX UNIT(SENSOR)	45PIN 0.3FFC
11	RFKZ0477	FP3902(MAIN) - MOUNT BOX UNIT(SENSOR)	45PIN 0.3FFC
12	RFKZ0477	FP3903(MAIN) - MOUNT BOX UNIT(SENSOR)	45PIN 0.3FFC
13	RFKZ0477	FP3904(MAIN) - MOUNT BOX UNIT(SENSOR)	45PIN 0.3FFC
14	RFKZ0564	FP9008(MAIN) - MOUNT BOX UNIT(LENS I/F)	23PIN 0.3FFC
15	RFKZ0359	P9002(MAIN) - MOUNT BOX UNIT(SSWF)	2PIN CONNECTOR
16	RFKZ0359	P8503(POW FLASH) - FLASH UNIT	2PIN CONNECTOR
17	VFK1576DC202	P8504(POW FLASH) - FLASH UNIT	2PIN CONNECTOR
18	VFK1576DC202	P9005(MAIN) - HINGE SW P.C.B.	2PIN CONNECTOR

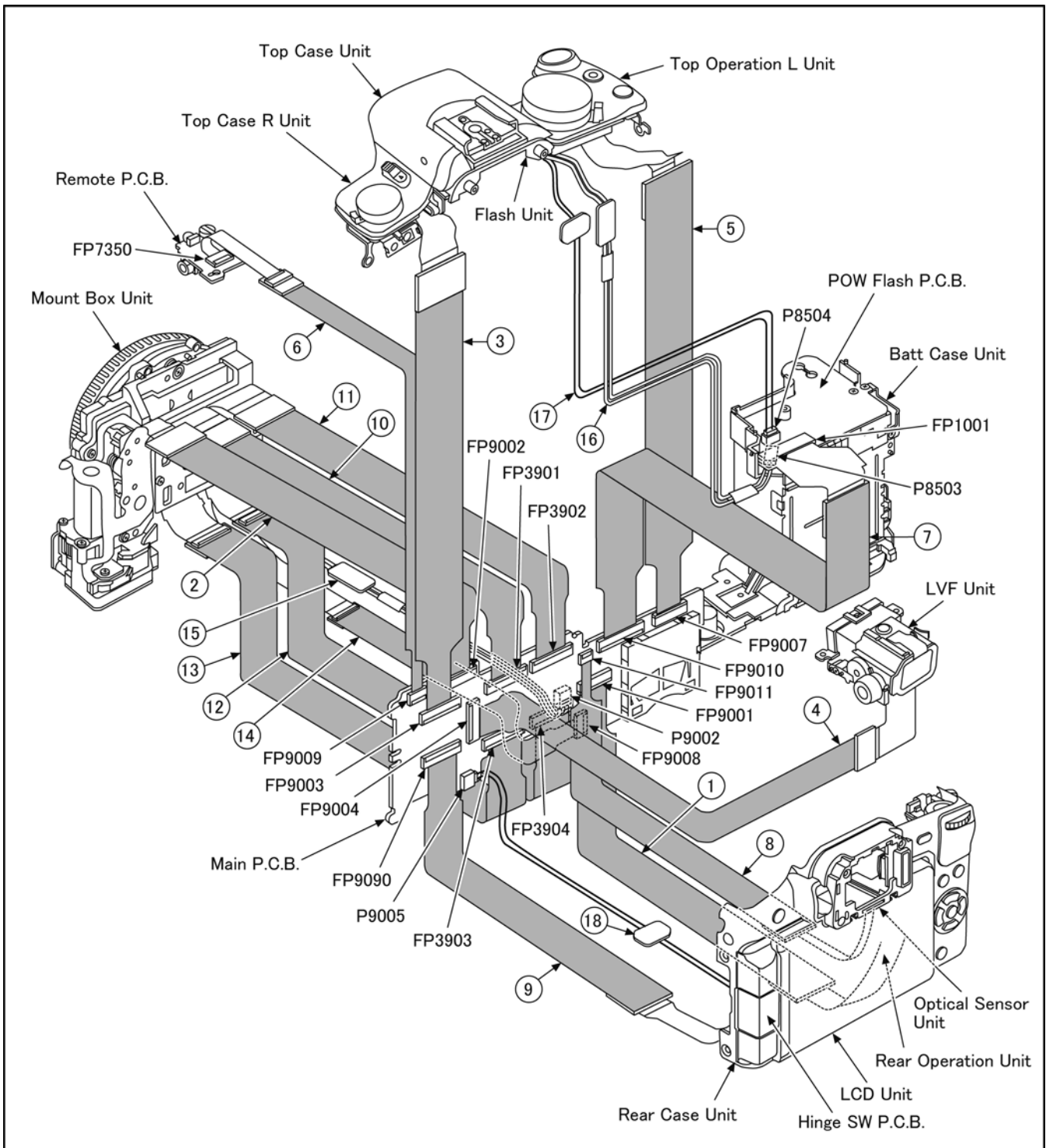

CAUTION-1. (When servicing POW FLASH P.C.B.)

1. Be sure to discharge the capacitor on POW FLASH P.C.B..
Refer to "HOW TO DISCHARGE THE CAPACITOR ON POW FLASH P.C.B.".
The capacitor voltage is not lowered soon even if the AC Cord is unplugged or the battery is removed.
2. Be careful of the high voltage circuit on POW FLASH P.C.B..
3. DO NOT allow other parts to touch the high voltage circuit on POW FLASH P.C.B..

9 Disassembly and Assembly Instructions

9.1. Camera Body Part

9.1.1. Disassembly Flow Chart

This is a disassembling chart.

When assembling, perform this chart conversely.

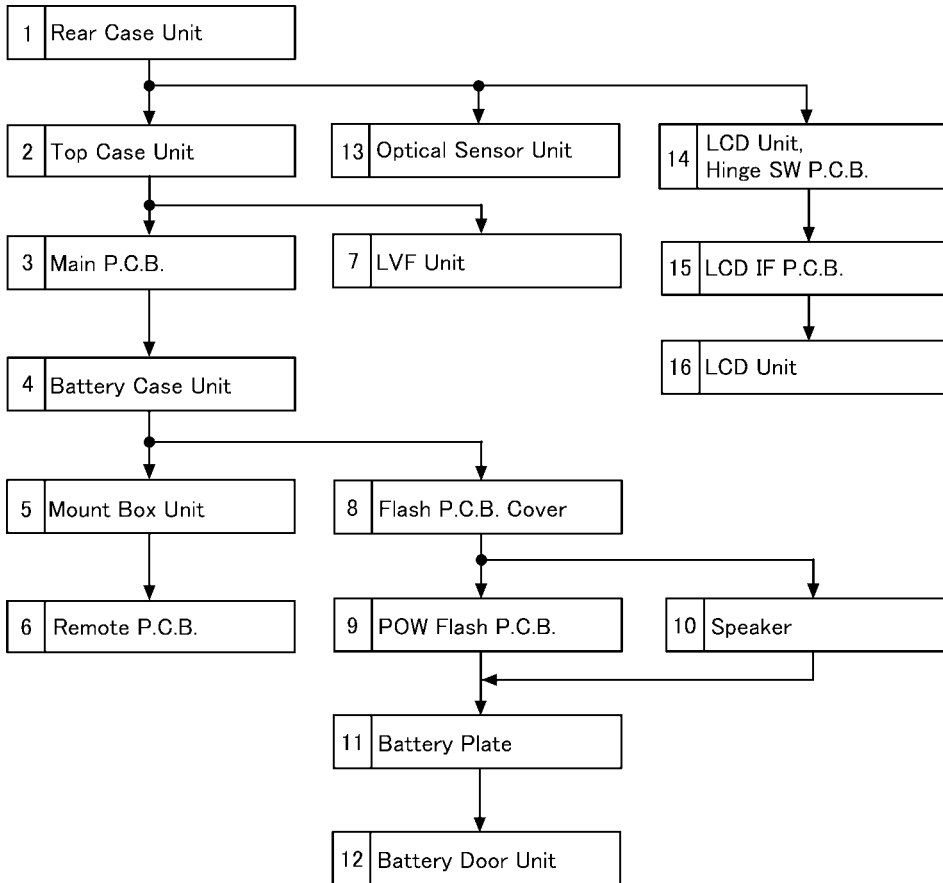

9.1.2. P.C.B. Location

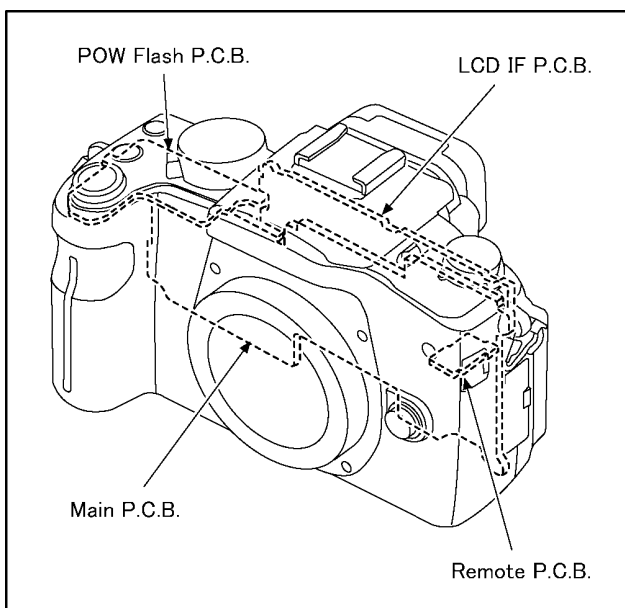

9.1.3. Disassembly Procedure

No.	Item	Fig	Removal			
1	Rear Case Unit	(Fig. D1)	7 Screws (A)			
			3 Screws (B)			
		(Fig. D2)	1 Screw (C)			
			Eye Cup Unit			
			2 Screws (D)			
		(Fig. D3)	FP9001(Flex)			
			FP9011(Flex)			
			FP9090(Flex)			
			P9005(Connector)			
			Rear Case Unit			
2	Top Case Unit	(Fig. D4)	2 Screws (E)			
		(Fig. D5)	1 Screw (F)			
			FP9003(Flex)			
			FP9004(Flex)			
			FP9007(Flex)			
			FP9010(Flex)			
			P8503(Connector)			
			P8504(Connector)			
			Top Case Unit			
			3	Main P.C.B.	(Fig. D6)	1 Screw (G)
2 Screws (H)						
FP3901(Flex)						
FP3902(Flex)						
FP3903(Flex)						
FP3904(Flex)						
FP9002(Flex)						
FP9008(Flex)						
FP9009(Flex)						
P3901(Connector)						
P9002(Connector)						
Main P.C.B.						
4	Battery Case Unit	(Fig. D7)				3 Screws (I)
						Battery Case Unit
5	Mount Box Unit	(Fig. D8)	4 Screws (J)			
		(Fig. D9)	Mount Box Unit			
6	Remote P.C.B.	(Fig. D10)	1 Screw (K)			
			1 Screw (L)			
			Jack Cover			
			Remote Cover			
			AF Light Case			
			1 Screw (M)			
			Side Frame R			
			Jack Holder			
			Remote Holder			
			Remote P.C.B.			
7	LVF Unit	(Fig. D11)	2 Screws (N)			
			LVF Unit			
8	Flash P.C.B. Cover	(Fig. D12)	1 Screw (O)			
			2 Locking tabs			
			Flash P.C.B. Cover			
9	POW Flash P.C.B.	(Fig. D13)	2 Screws (P)			
			4 Solders			
			P1002(Connector)			
			POW Flash P.C.B.			
10	Speaker	(Fig. D14)	2 Screws (Q)			
			2 Screws (R)			
			Side Plate L			
			P1002(Connector)			
			Speaker			
11	Battery Plate	(Fig. D15)	1 Screw (S)			
			1 Screw (T)			
			Tripod Frame Unit			
			3 Locking tabs			
			Battery Plate			

No.	Item	Fig	Removal
12	Battery Door Unit	(Fig. D16)	Battery Door Shaft
			Battery Door Spring
			Battery Door Unit
13	Optical Sensor Unit	(Fig. D17)	1 Hanging part
			Eye Sensor FPC
			2 Screws (U)
			Eye Plate
			Optical Sensor Unit
14	LCD Unit, Hinge SW P.C.B.	(Fig. D18)	1 Screw (V)
			2 Screws (W)
			Strap (R) Unit
		(Fig. D19)	Hinge Arm Cover Top
			Hinge Arm Cover Bottom
			2 Screws (X)
			Hinge Plate
			2 Ribs
			1 Screw (Y)
			LCD Unit
Hinge SW P.C.B.			
15	LCD IF P.C.B.	(Fig. D20)	2 Screws (a)
			2 Screws (b)
			6 Locking tabs
			LCD Case Bottom Unit
			LCD Hinge Unit
			FP7202(Flex)
			FP7203(Flex)
			FP7204(Flex)
FP7205(Flex)			
16	LCD Unit	(Fig. D21)	LCD BL Bezel Sheet
			LCD Case Top Unit
			LCD Unit

NOTE:

When servicing and reassembling, remove the card and battery from the unit.

- Card
- Battery

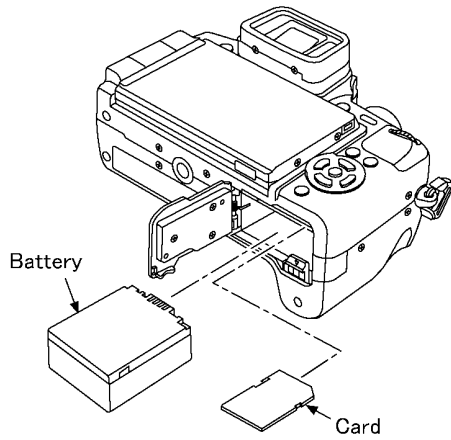

9.1.3.1. Removal of the Rear Case Unit

- Screw (A) × 7
- Screw (B) × 3

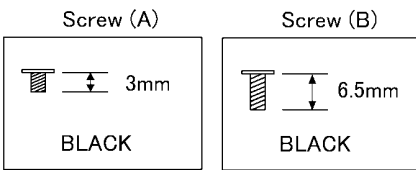
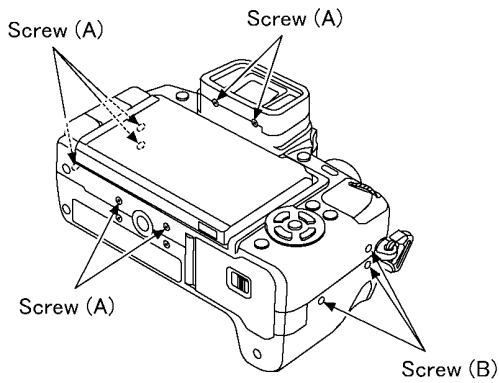

(Fig. D1)

- Screw (C) × 1
- Screw (D) × 2
- Eye Cup Unit

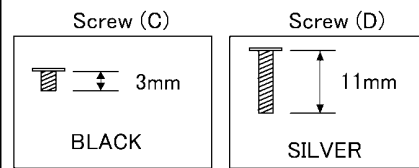
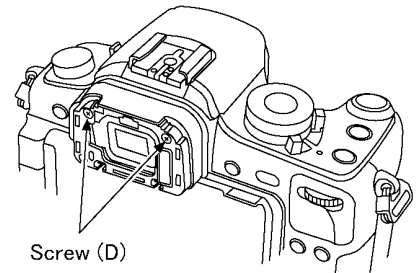
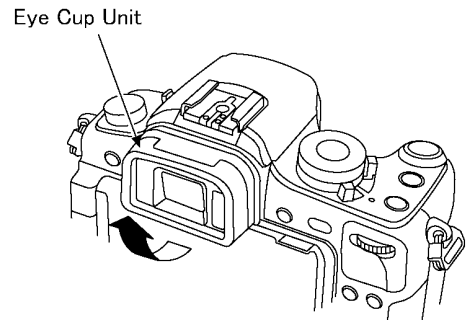
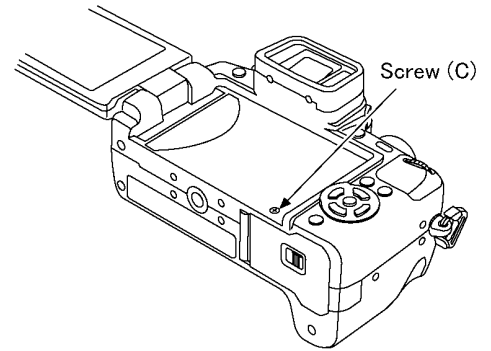

(Fig. D2)

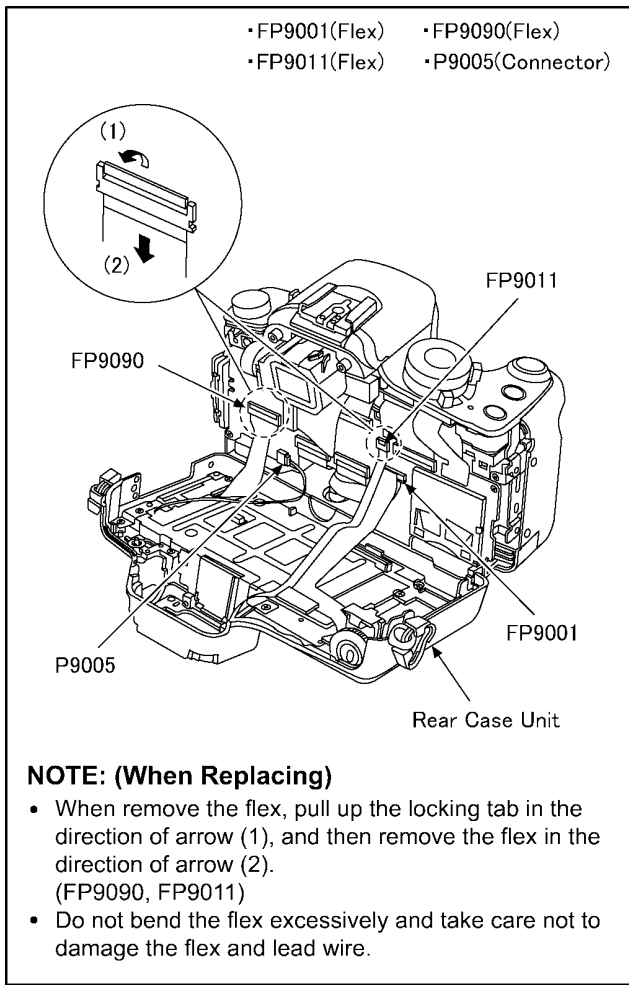

(Fig. D3)

9.1.3.2. Removal of the Top Case Unit

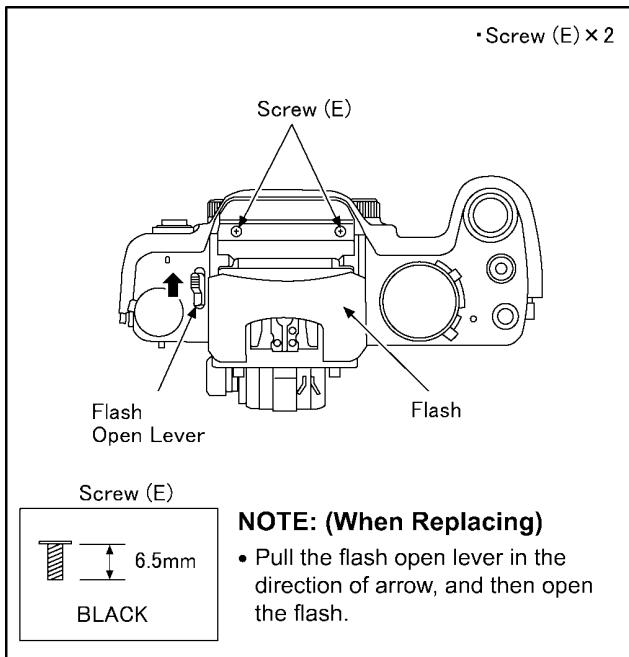

(Fig. D4)

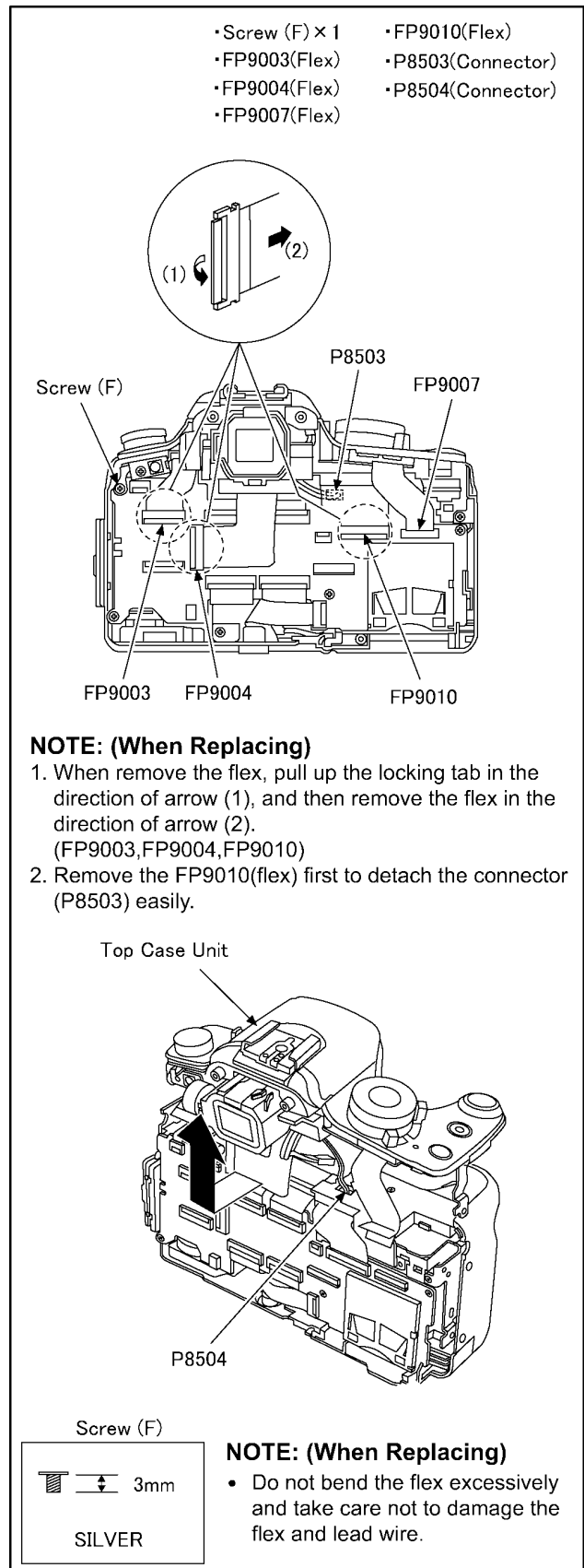

(Fig. D5)

9.1.3.3. Removal of the Main P.C.B.

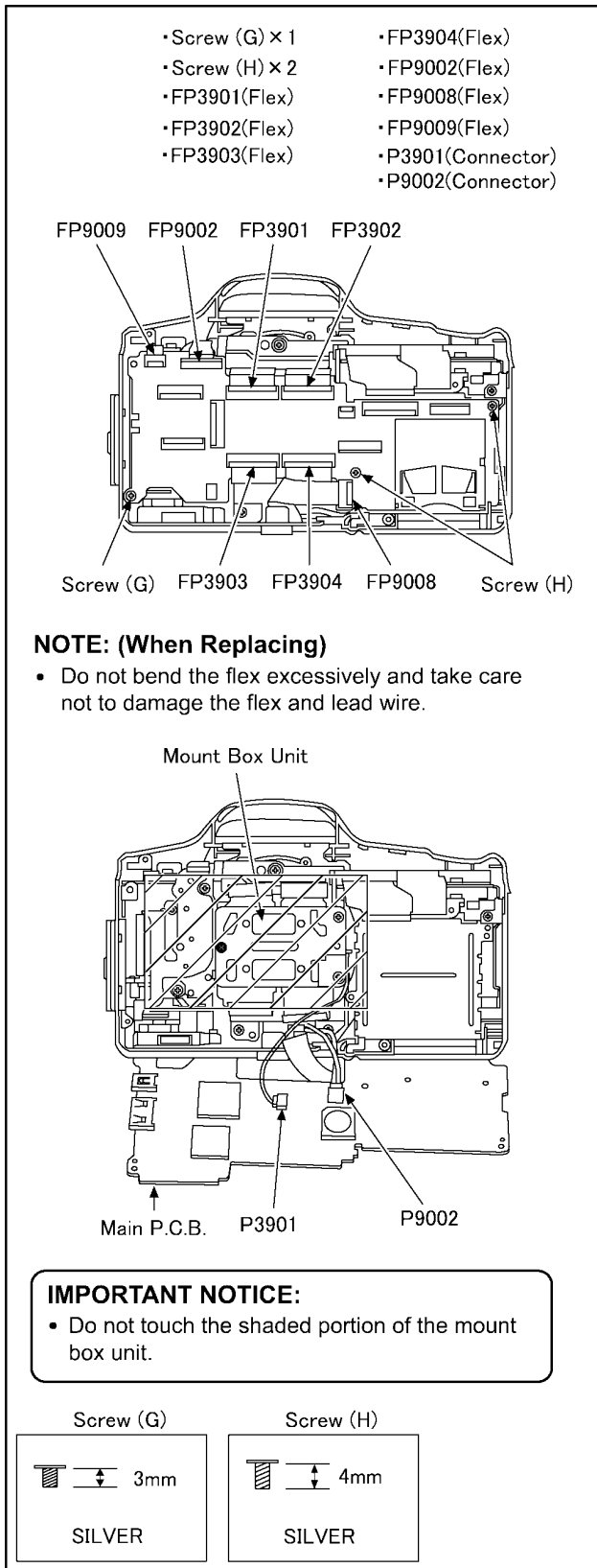

(Fig. D6)

9.1.3.4. Removal of the Battery Case Unit

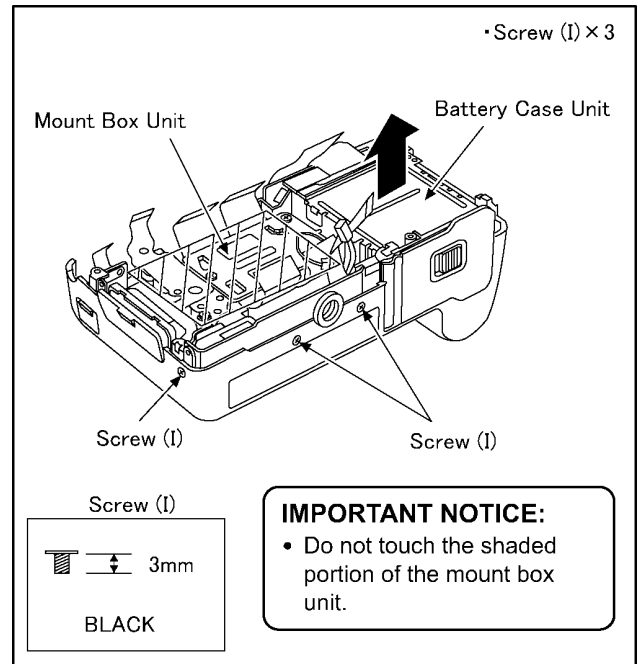

(Fig. D7)

9.1.3.5. Removal of the Mount Box Unit

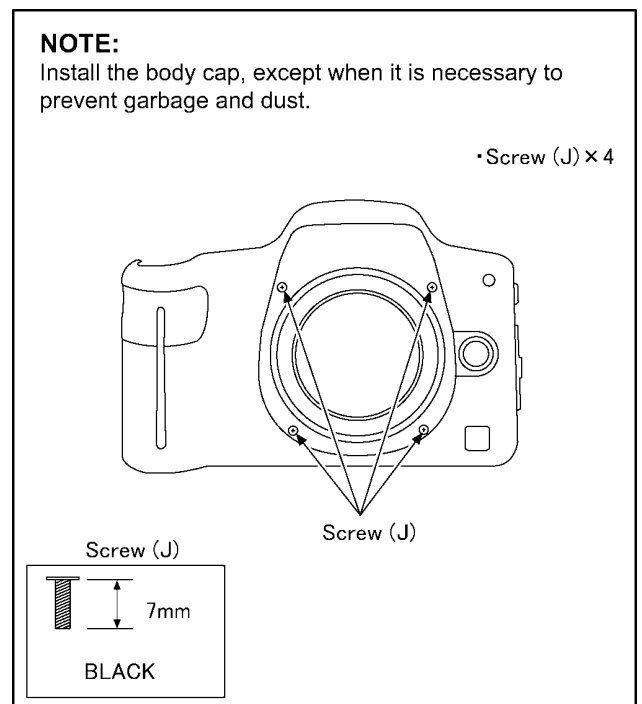

(Fig. D8)

9.1.3.6. Removal of the Remote P.C.B.

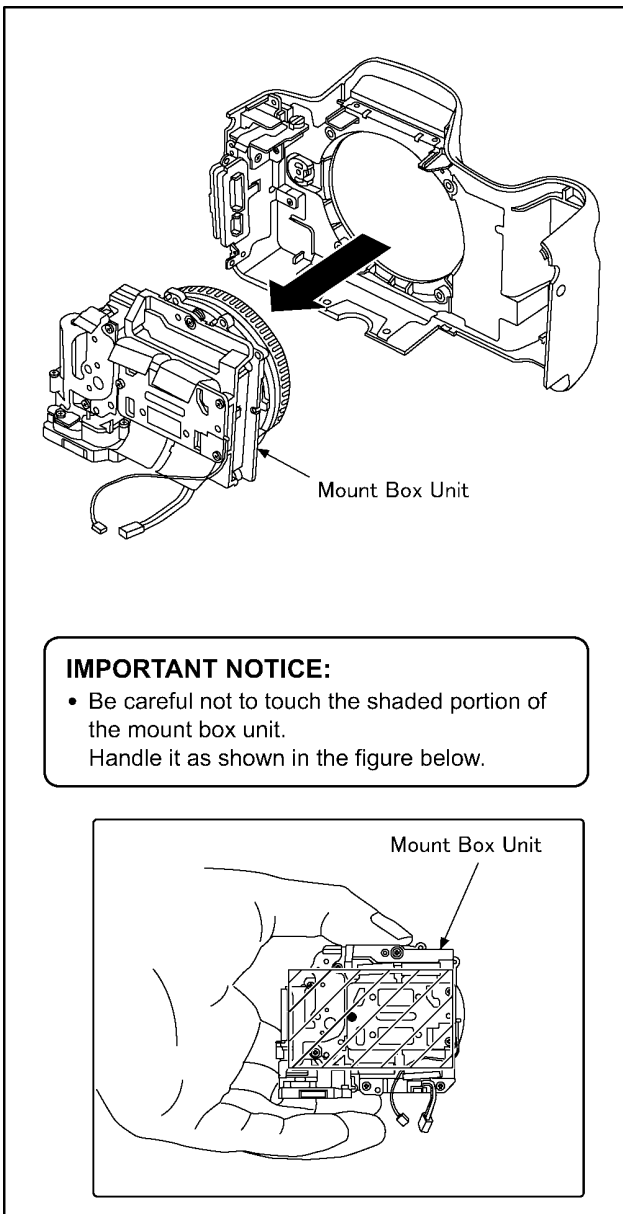

(Fig. D9)

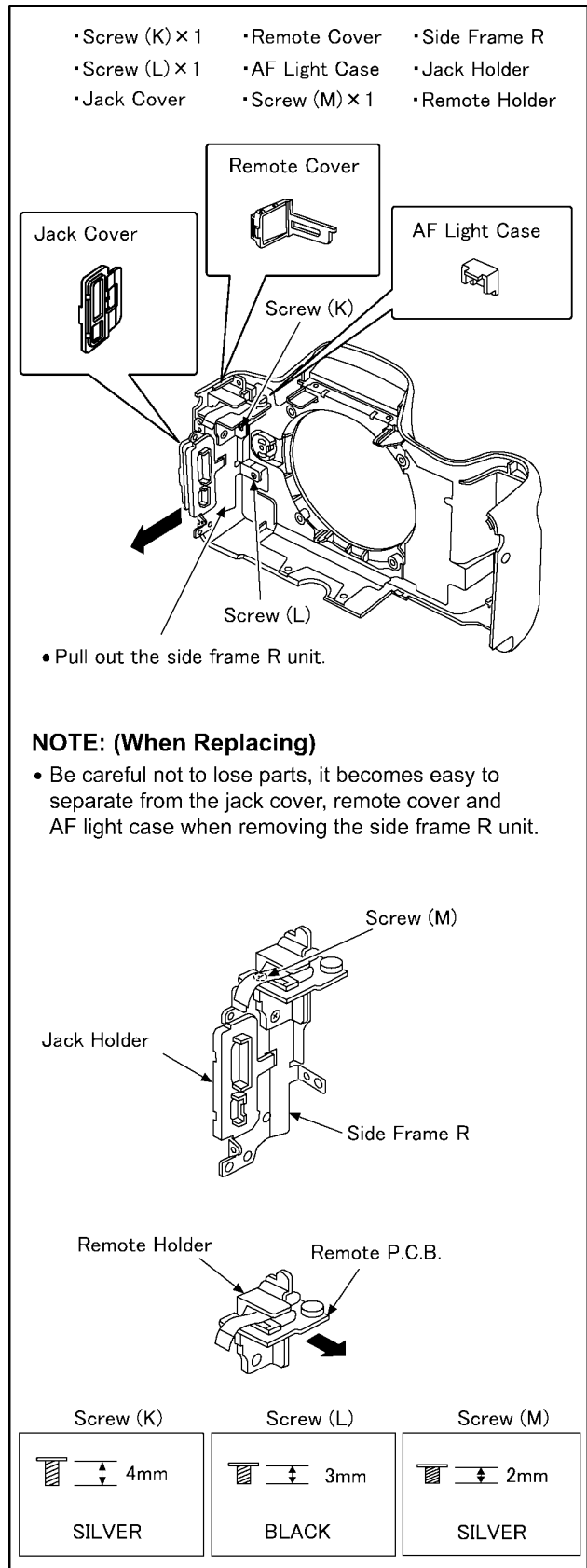

(Fig. D10)

9.1.3.7. Removal of the LVF Unit

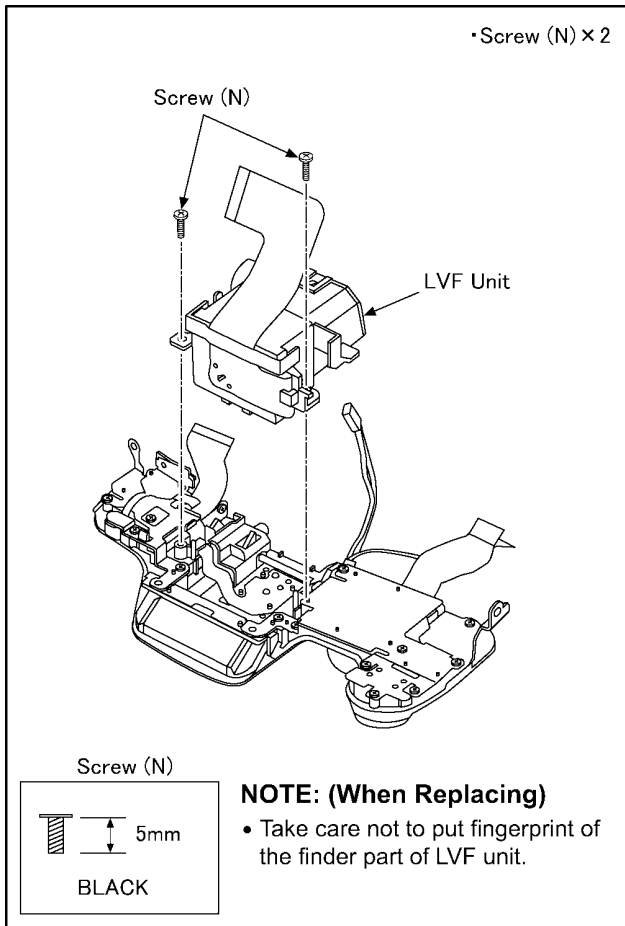

(Fig. D11)

9.1.3.8. Removal of the Flash P.C.B. Cover

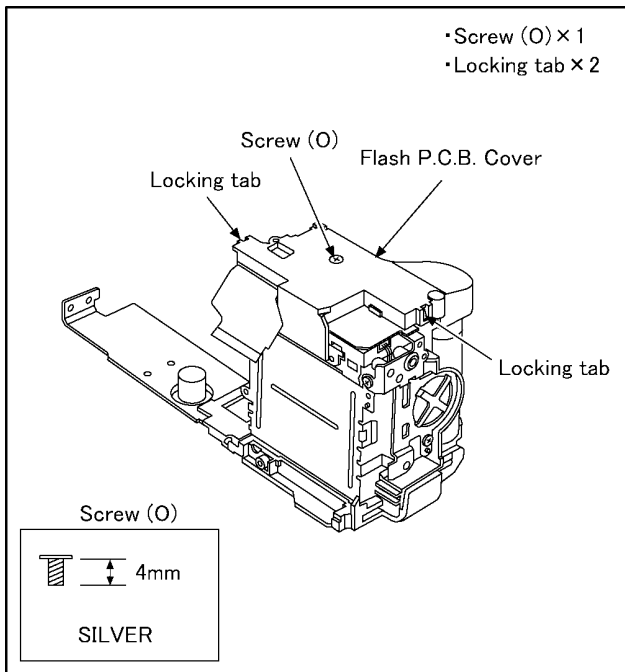

(Fig. D12)

9.1.3.9. Removal of the POW Flash P.C.B.

IMPORTANT NOTICE:

Take care not apply any bending load to the charging capacitor. It brings about the possibility of P.C.B. and/or component damage on the POW Flash P.C.B..

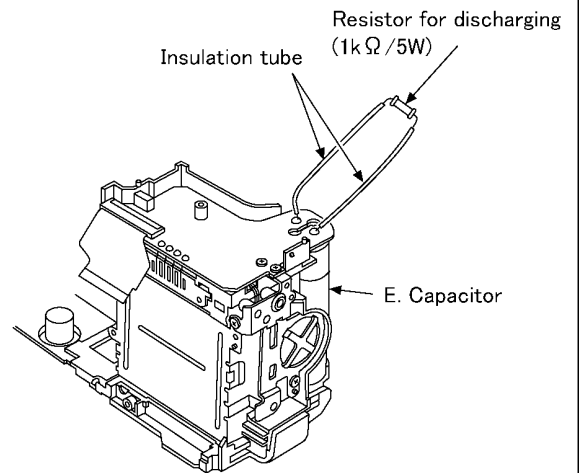

CAUTION

Be sure to discharge the capacitor on POW Flash P.C.B. before disassembling.

1. Put the insulation tube on the lead part of resistor (ERG5SJ102: 1kΩ/5W).
2. Put the resistor between both terminals of capacitor unit for approx. 5 seconds.

- Screw (P) × 2
- P1002(Connector)
- Solder (4 points)

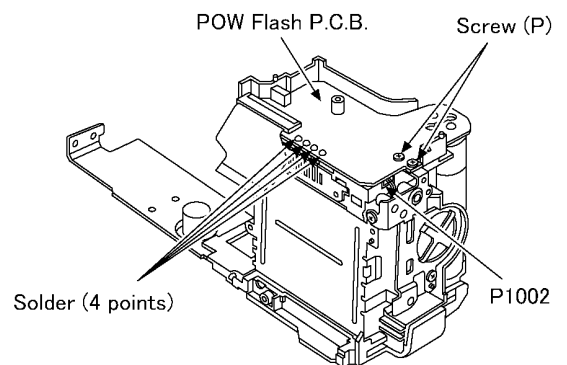

Screw (P)

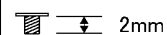

SILVER

(Fig. D13)

9.1.3.10. Removal of the Speaker

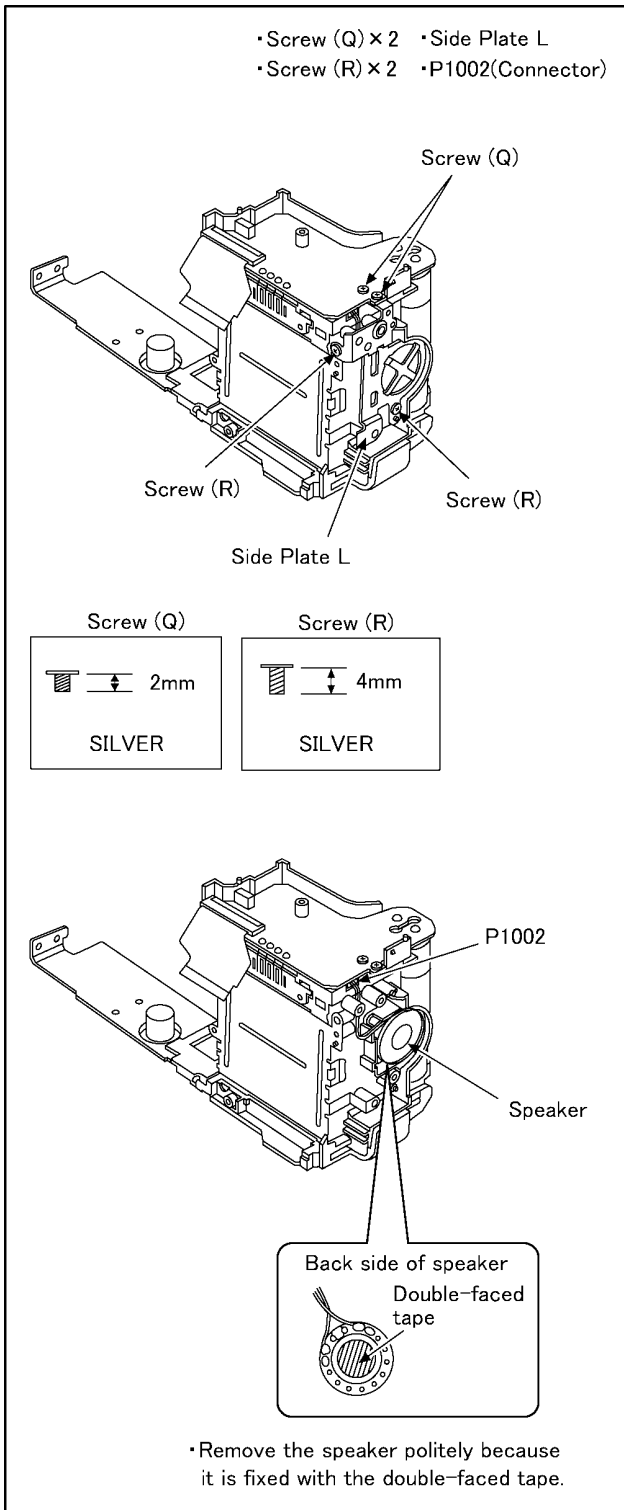

(Fig. D14)

9.1.3.11. Removal of the Battery Plate

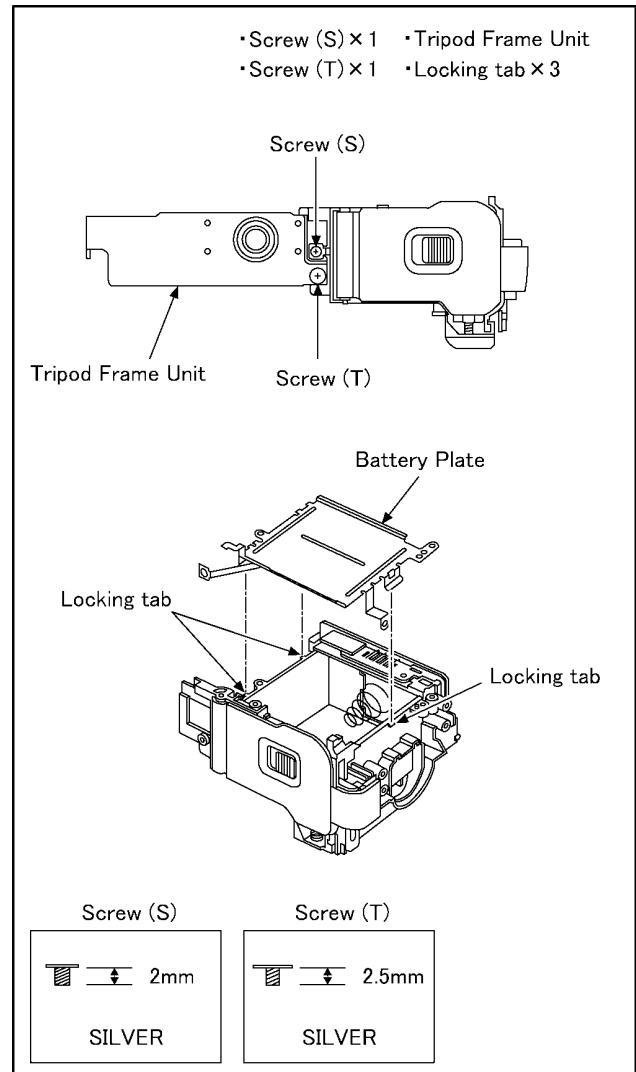

(Fig. D15)

9.1.3.12. Removal of the Battery Door Unit

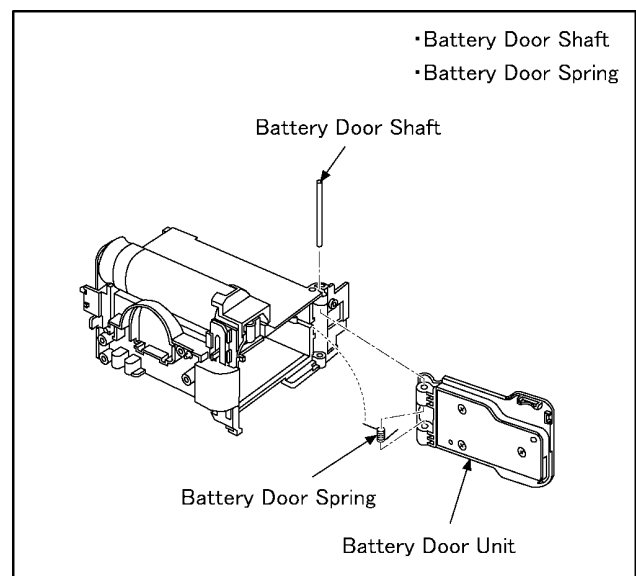

(Fig. D16)

9.1.3.13. Removal of the Optical Sensor Unit

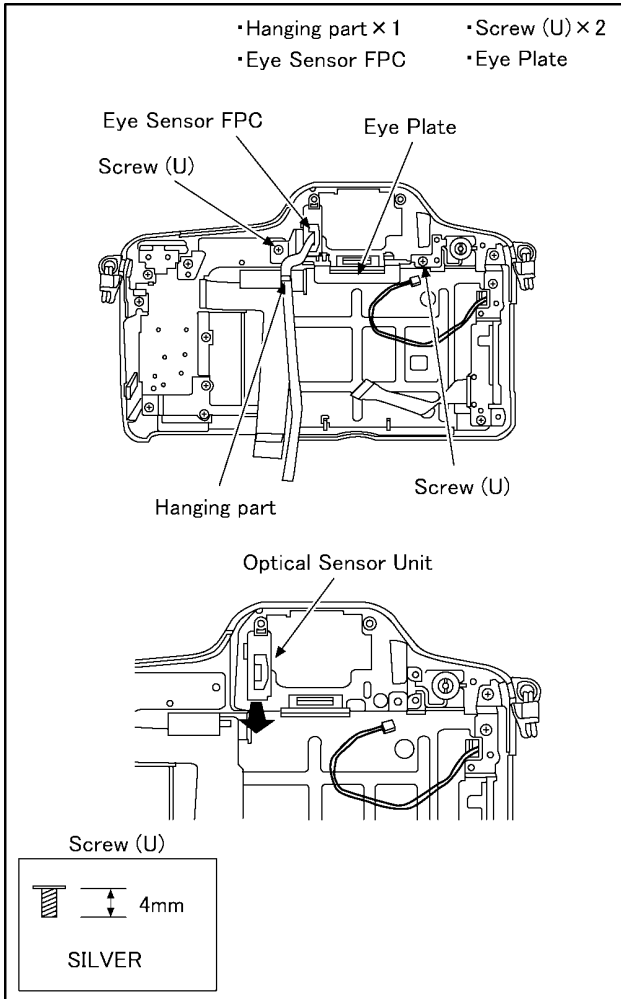

(Fig. D17)

9.1.3.14. Removal of the LCD Unit and Hinge SW P.C.B.

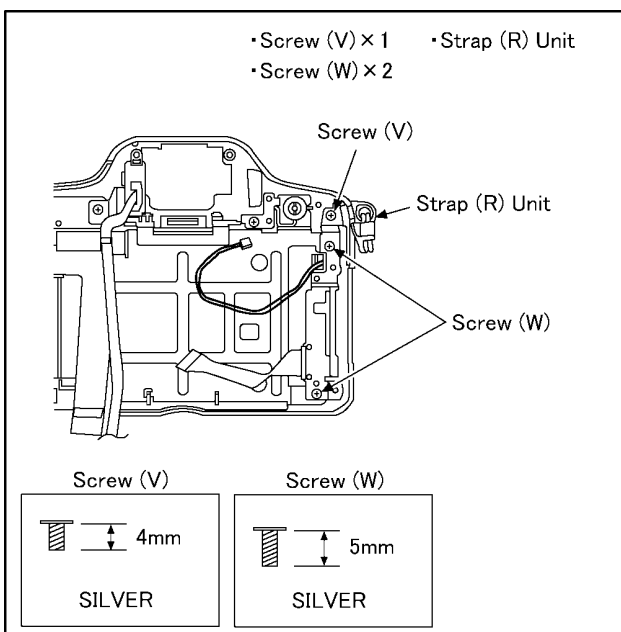

(Fig. D18)

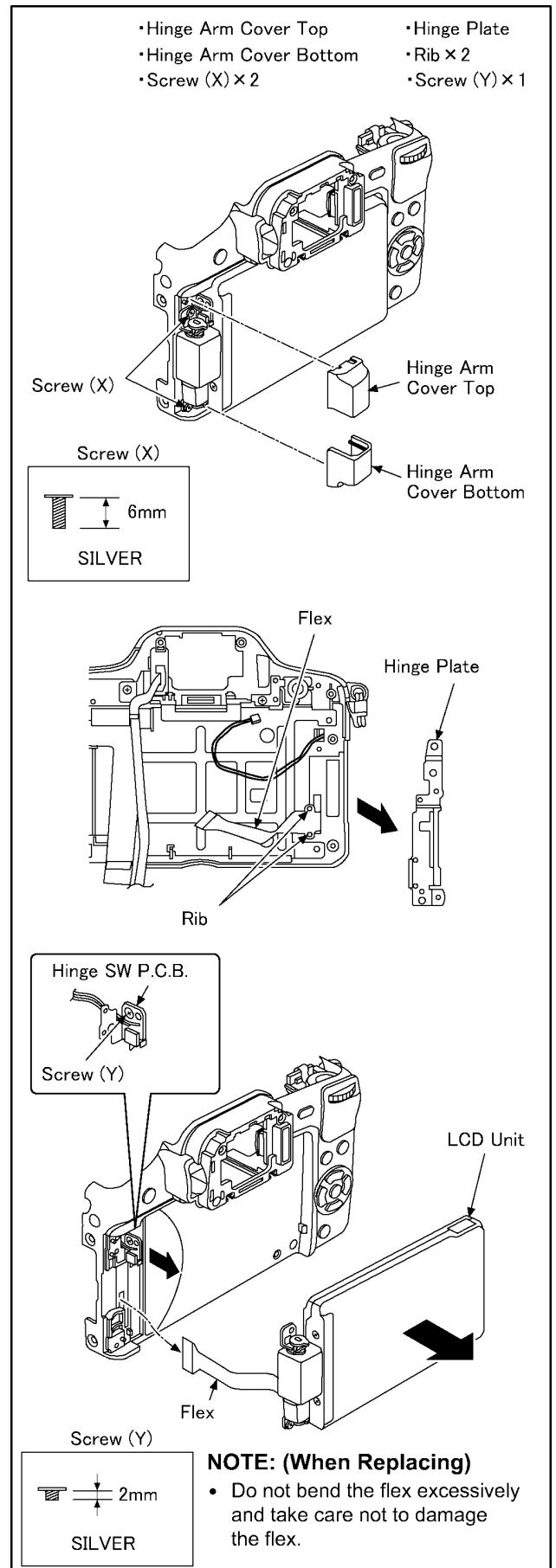

(Fig. D19)

9.1.3.15. Removal of the LCD IF P.C.B.

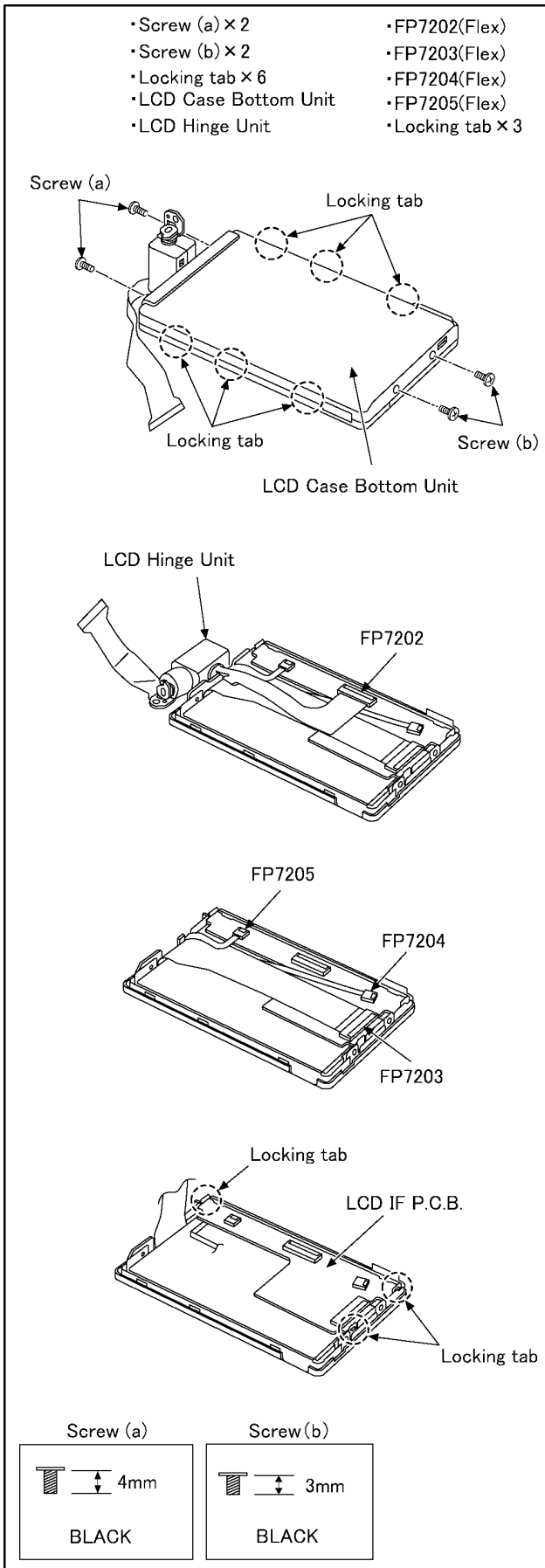

(Fig. D20)

9.1.3.16. Removal of the LCD Unit

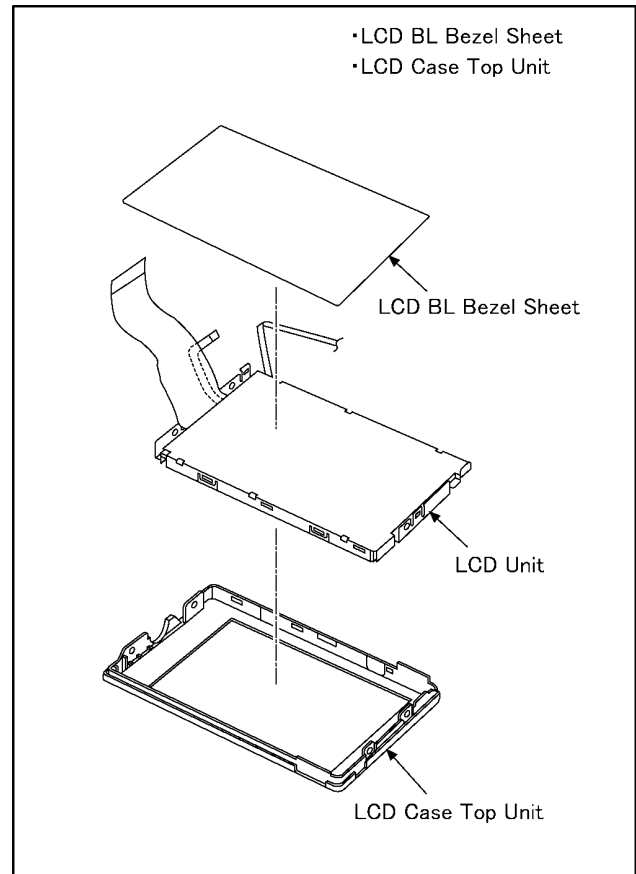

(Fig. D21)

NOTE: (When Installing)

Make sure to confirm the following points when installing:

- The Screw is tightened enough.
- Installing conditions are fine. (No distortion, no abnormal-space.)
- No dust and/or dirt on Lens surfaces.
- LCD image is fine. (No dust and dirt on it, and no gradient images.)

9.2. Disassembly and Assemble Procedure for the Lens (H-FS014042)

It is recommended dealing with clean box, to keep maintaining the dustproof environment.
(Refer to "8.2. Clean Box" section of this service manual for details.)

Important:

- When servicing the enclosure part (refer to Fig. K1), it must be performed inside of satisfied clean level.
(Satisfied clean level: Less than class 10,000 (Federal Standard 209D))
As for procedure, refer to the "11 Maintenance" for details.
- To minimize the possibilities/risk of getting the dust/dirt on the lens surface, keep covering the lens unit with lens caps (front & rear), other than necessary cases.
- Do not touch the surface of the lens glasses with your fingers.
- Blow off the dust on the surface of the lens with a blower brush.
- Use lens cleaning KIT (BK)(VFK1900BK).

Proceed disassemble/assemble, by referring the following table and Fig. K1.

NOTE:

- When installing the screws, be sure to use the torque driver (RFKZ0456) and tighten the screws with specified torque, mentioned on the above table.
- The Ref.B213 is no need to remove/install for disassembly and assembly.
If necessary, use VFK1390 (small driver) when screwing it.

Interchangeable Lens (H-FS014042)

Caution :
Keep covering the lens unit with Lens caps (front & rear), other than necessary cases.

Concerned parts		screws					Remarks
Part name	Ref. No.	Ref. No.	Color	Length (mm)	Order	Torque value	
Shading frame	202	B201	Black	4mm	1	7±0.5	
		B202	Black	4mm	2	7±0.5	
		B203	Black	4mm	3	7±0.5	
L mount unit	206	B208	Black	5mm	2	15±1.2	
		B209	Black	5mm	4	15±1.2	
		B210	Black	5mm	3	15±1.2	
		B211	Black	5mm	1	15±1.2	
		B213	Black	3mm	----	----	Use Small Driver (VFK1390)
Rear frame 2 unit	207	B204	Black	4mm	1	7±0.5	
		B205	Black	4mm	4	7±0.5	
		B206	Black	4mm	3	7±0.5	
		B207	Black	4mm	2	7±0.5	

Refer to the "11.2.1. Disassembly procedure" of the "11 Maintenance" when disassemble and assemble this part.

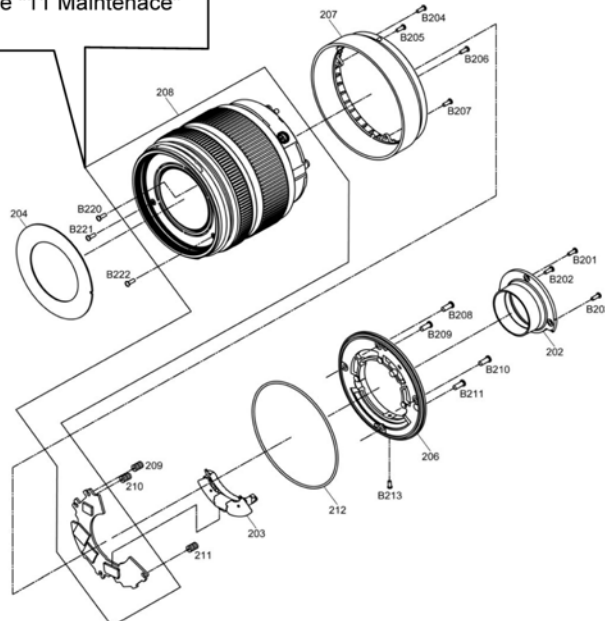

(Fig. K1)

9.3. Disassembly and Assemble Procedure for the Lens (H-FS045200)

It is recommended dealing with clean box, to keep maintaining the dustproof environment.
(Refer to "8.2. Clean Box" section of this service manual for details.)

Important:

1. When servicing the enclosure part (refer to Fig. W1), it must be performed inside of satisfied clean level.
(Satisfied clean level: Less than class 10,000 (Federal Standard 209D))
As for procedure, refer to the "11 Maintenance" for details.
2. To minimize the possibilities/risk of getting the dust/dirt on the lens surface, keep covering the lens unit with lens caps (front & rear), other than necessary cases.
3. Do not touch the surface of the lens glasses with your fingers.
4. Blow off the dust on the surface of the lens with a blower brush.
5. Use lens cleaning KIT (BK)(VFK1900BK).

Proceed disassemble/assemble, by referring the following table and Fig. W1.

NOTE:

1. When installing the screws, be sure to use the torque driver (RFKZ0456) and tighten the screws with specified torque, mentioned on the above table.
2. The Ref.B309 is no need to remove/install for disassembly and assembly.
3. Use small driver (VFK1390) when removing/tighten the B308.

Interchangeable Lens (H-FS045200)

Caution :
Keep covering the lens unit with Lens caps (front & rear), other than necessary cases.

Concerned parts		screws					Remarks
Part name	Ref. No.	Ref. No.	Color	Length (mm)	Order	Torque value	
Shading frame	303	B301	Black	2.5 mm	10	9.8±1.0	
		B302	Black	2.5 mm	12	9.8±1.0	
		B303	Black	2.5 mm	11	9.8±1.0	
L mount unit	306	B304	Silver	5.0 mm	4	19.6±1.0	
		B305	Silver	5.0 mm	6	19.6±1.0	
		B306	Silver	5.0 mm	7	19.6±1.0	
		B307	Silver	5.0 mm	5	19.6±1.0	
		B318	Silver	1.2 mm	9	9.8±1.0	
Mount contact unit	304	B308	Silver	3.5 mm	----	----	Use Small Driver (VFK1390)
Rear frame unit	307	B310	Silver	7.0 mm	2	19.6±1.0	
		B311	Silver	7.0 mm	1	19.6±1.0	
		B312	Silver	7.0 mm	3	19.6±1.0	

Refer to the "11.3.1. Disassembly procedure" of the "11 Maintenance" when disassemble and assemble this part.

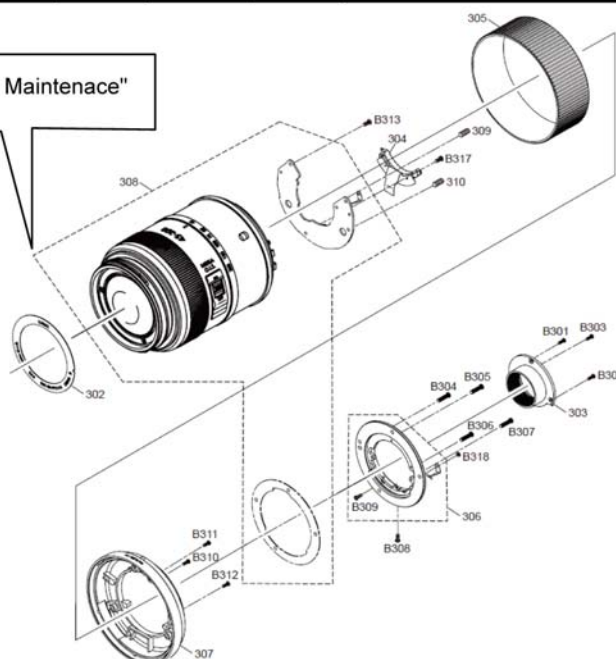

(Fig. W1)

10 Measurements and Adjustments

10.1. Matrix Chart for Replaced Part and Necessary Adjustment

The relation between Replaced part and Necessary Adjustment is shown in the following table.

When concerned part is replaced, be sure to achieve the necessary adjustment(s).

As for Adjustment condition/procedure, consult the "Adjustment Manual" which is available in Adjustment software.

NOTE:

After adjustments have been terminated, make sure to achieve "INITIAL SETTINGS".

After updates it to the latest firmware, the adjustment is executed.

Adjustment Item		Mount Box Unit (*3)	Main P.C.B. (*2)	Flash-ROM (IC6007) (*2)	•Flash •Power P.C.B.	Eye sensor	LCDu	LVFu (EVFu)	•Lens u •L-Mount •Rear Frame etc	T. Panel Driver (IC7201)	
S e c o n d a r y	C a m e r a	VENUS-ZOOM Inspection (PZM)	—	○	○	—	—	—	—	—	
		ISO sensitivity adjustment (ISO)	○	○	○	—	—	—	—	—	
		High brightness coloration inspection (SEN)	○	○	○	—	—	—	—	—	
		Offset gain adjustment (SAT)	○	○	○	—	—	—	—	—	
		AWB adjustment (WBL/WBM)	○	○	○	—	—	—	—	—	
		IMAGE SENSOR white scratch compensation (WKI)	○	○	○	—	—	—	—	—	
		IMAGE SENSOR black scratch compensation (BKI)	○	○	○	—	—	—	—	—	
		Low illumination image quality correction (VSJ)	○	○	○	—	—	—	—	—	
		Eye sensor sensitivity (EYE)	—	○	○	—	○	—	—	—	—
		Mount Box Adjustment data writing	○	—	—	—	—	—	—	—	—
		Mount box u readjustment	—	○	○	—	—	—	—	—	—
	AVCHD function inspection	—	○ (*4)	○ (*4)	—	—	—	—	—	—	
Display	Touch panel adjustment (TPC)	—	○	○	—	—	○	—	—	○	
Defect Part Division/Inspection	Resolution inspection (*1)	○	—	—	—	—	—	—	—	—	

- *1
- Inspect it, not only corresponding part is replaced, but also camera body is shocked and/or dropped.
 - The DMC-G1/DMC-GH1/DMC-GF1 unit (marketed commodity: operates normal) etc. in accordance with the Micro Four Thirds System and normal zoom lens H-FS014045 (marketed commodity) are necessary.
 - Refer to the adjustment instruction in the adjustment software for details.

*2 NOTE: (When exchange the MAIN P.C.B.)

- Correspond by either the following when exchange the MAIN P.C.B. unavoidably by destruction and damage etc. of MAIN P.C.B..
 1. When it can turn on power, and the adjustment software can communicate with the camera body:
 - Before replacing, proceed the FLASH-ROM data backup from the unit. After replacing, overwrite the FLASH-ROM data with backup data from the unit, before proceeding the main body adjustment.
 2. When it cannot turn on power, or the adjustment software cannot communicate with the camera body:
 - The readjustment of mount box unit etc. are necessary.
 - Refer to the adjustment instruction in the adjustment software for details.

***3 NOTE: (After exchange the mount box unit)**

- Execute the resolution inspection by the comparison with the standard model (DMC-G1K etc.: operates normal).
- Refer to the adjustment instruction in the adjustment software for details.

***4**

- Confirm self recording/playback motion picture of AVCHD mode by the LCD.
- Confirm it on the TV with HDMI socket when repair HDMI relation.

* There are no LCD/LVF adjustment model.

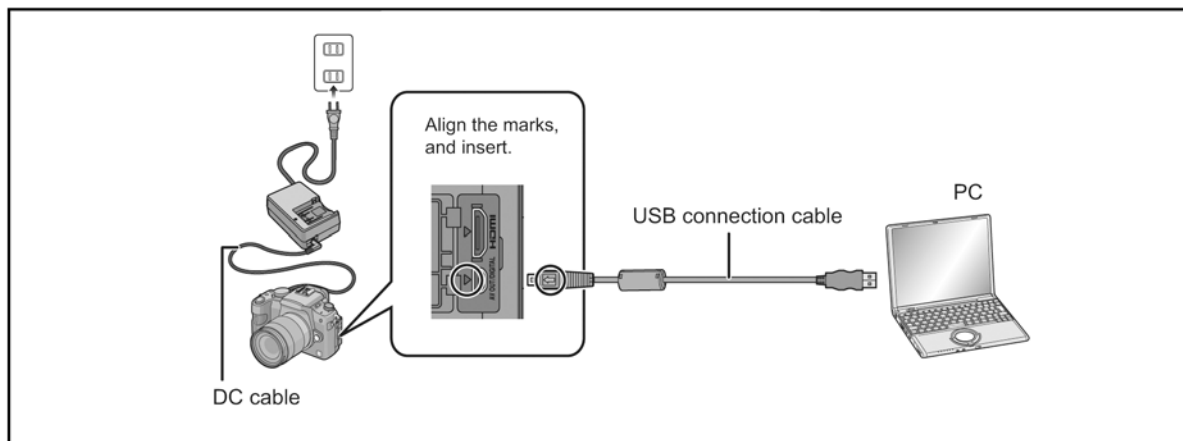

11 Maintenance

11.1. Notice in external cleaning

11.1.1. ABOUT THE BODY

NOTE:

Before cleaning the camera, remove the battery and/or disconnect power plug from the outlet.
Also, remove the SD Memory card and lens unit.

11.1.1.1. DUST/DIRT ON THE OUTER CASING PART (S)

1. Blow off the dust first, then sweep out the dust from narrower spaces with soft cleaning brush.
2. Wipe up fingerprint and/or dirt on the Outer casing part with the dry fuzz-free cloth.

11.1.1.2. DUST/DIRT ON THE IMAGE SENSOR

1. Blow off the dust on the surface of the Image sensor with the Blower. (Refer to the following Figure.)
 - Keep the Mount Facing down condition towards to floor when cleaning.
 - Do not put the Blower further inside than the lens mount.
 - Be careful not to blow too strongly.
2. Wipe off the dirt on the image sensor surface with Lens cleaning KIT(BK)(VFK1900BK).

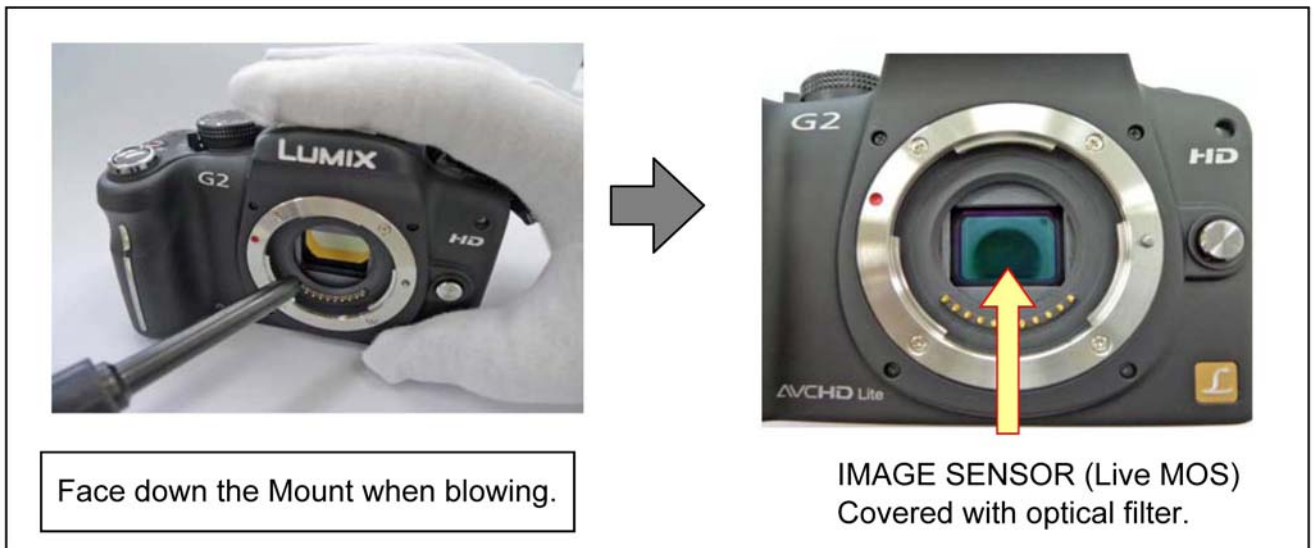

11.1.1.3. ABOUT THE LVF UNIT

[PROCEDURES]

1. By referring the Disassembly & Assembly procedures and remove the LVF unit.
2. Disassemble the LVF unit as follows, then blow off the dust with blower.
3. Wipe off the dirt on the surface of glasses with Lens Cleanig KIT (VFK1900BK), if necessary.

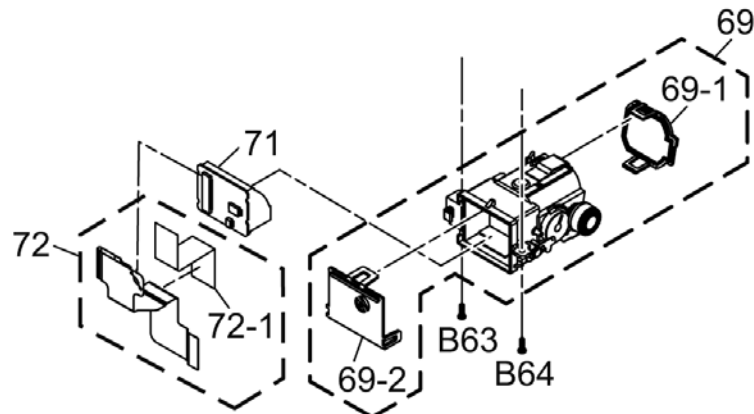

11.1.2. ABOUT THE LENS

11.1.2.1. DUST/DIRT ON THE OUTER CASING PART(S)

1. Blow off the dust first, then sweep out the dust from narrower spaces with soft cleaning brush.
2. Wipe up the Outer casing part with the dry fuzz-free cloth.

11.1.2.2. DUST/DIRT ON THE LENS GLASSES

- Define the location of the dust/dirt first, whether it is outside lens surface or not.
 1. When it is outside surface of the lens:
 - When the dust and/or dirt gets on the outer side surface of the Lens glasses, order the following procedures.
 - a. Blow off the dust on the Lens glass surface with the Blower, gently. (Do not Blow too strongly.)
 - b. Wipe out the dirt on the lens glass surface with Lens cleaning KIT(BK) (VFK1900BK) if necessary. (Consult the Instruction sheet which is included in the Lens cleaning KIT(BK) in details.)
 2. When it is inside of the lens:
 - Refer to the "11.2. General description (Lens cleaning: Interchangeable Lens/H-FS014042)", "11.3. General description (Lens cleaning: Interchangeable Lens/H-FS045200)" section of this service manual.

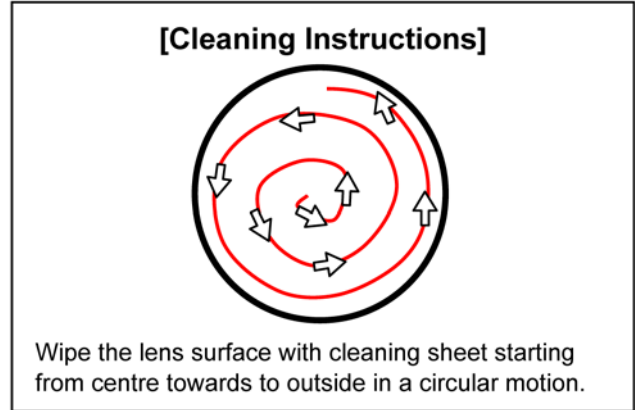

11.2. General description (Lens cleaning: Interchangeable Lens/H-FS014042)

When there is a dust/dirt inside surface of the 1st lens frame unit and/or subject side surface of the 2nd lens frame unit, remove it by referring the following procedures.

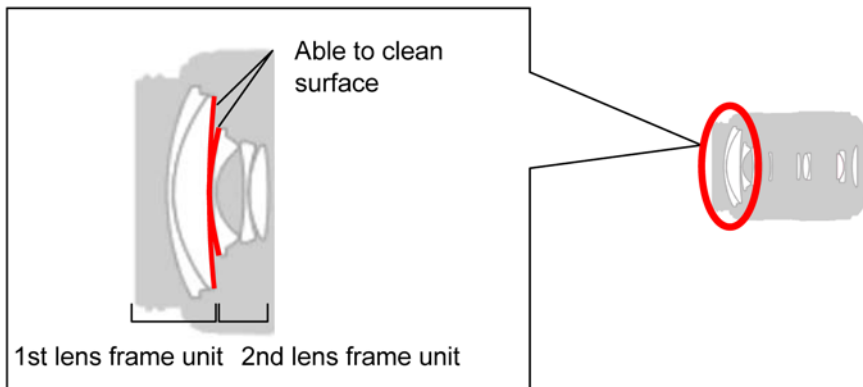

CAUTION

*DO NOT REMOVE 1st LENS FRAME UNIT OTHER THAN INSIDE OF SPECIFIED CLEAN LEVEL.
(Specified clean level: Less than class 10,000 (Federal Standard 209D))

Important:

1. When removing the 1st lens frame unit, it has to be proceed inside of satisfied clean level. (Less than class 10,000 (Federal Standard 209D))
As for clean box, refer to the "8.2. Clean Box", in details.
2. When tighten the screws (A), use torque driver (RFKZ0456) with specified torque.
3. To keep the Lens performance, use only the 1st lens frame unit which was fitted as it was.
Therefore, the 1st lens frame unit is not supplied as spare parts.
Also do not exchange the 1st lens unit taking from others.

11.2.1. Disassembly procedure

Important:

It must be performed inside of satisfied clean level.
(Satisfied clean level: Less than class 10,000 (Federal Standard 209D))

11.2.1.1. Removal of the Decoration Ring

1. Decoration ring is stuck on the 1st lens frame unit.
2. Put the sheet so that the lens glass is fully covered.
3. Insert the needle to Gap (A) (between the decoration ring and lens glass), and peel off the decoration ring gently.

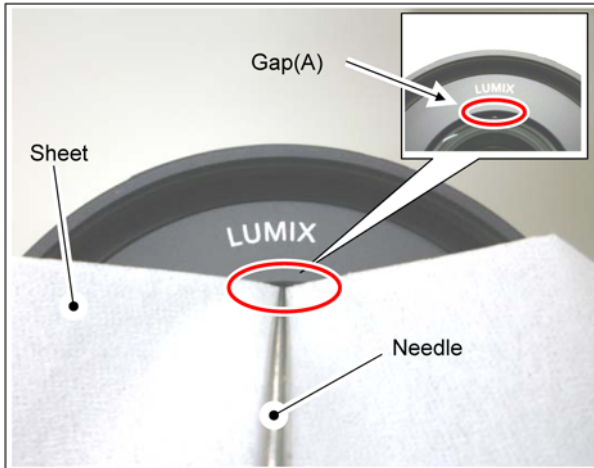

11.2.1.2. Removal of the 1st Lens Frame Unit

1. Remove the 3 screws (A).

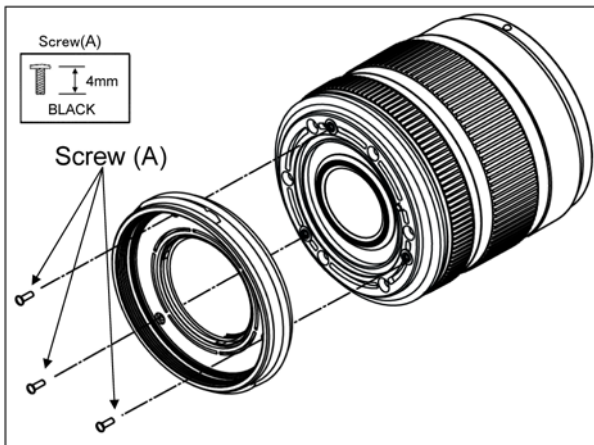

11.2.1.3. Removal of a dust /dirt

1. Blow off the dust on the surface of the lens with a blower brush.
2. Use lens cleaning KIT(BK) (VFK1900BK), if necessary.

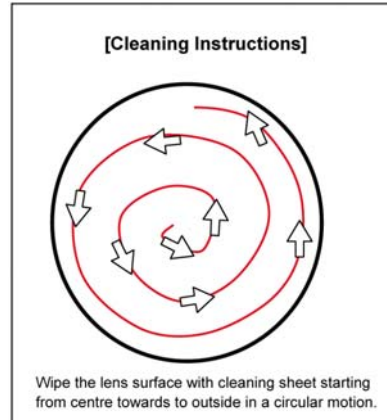

11.2.2. Assembly procedure

Important:

When tightening the screw, use a torque driver (RFKZ0456) by ordering the screwing order with specified torque described in each step.

11.2.2.1. Installation of the 1st lens frame unit

1. Tighten the 3 screws (A) with specified torque in numerical order.
(Torque Driver: RFKZ0456)
(Torque: 10 ± 1.0 N·cm)

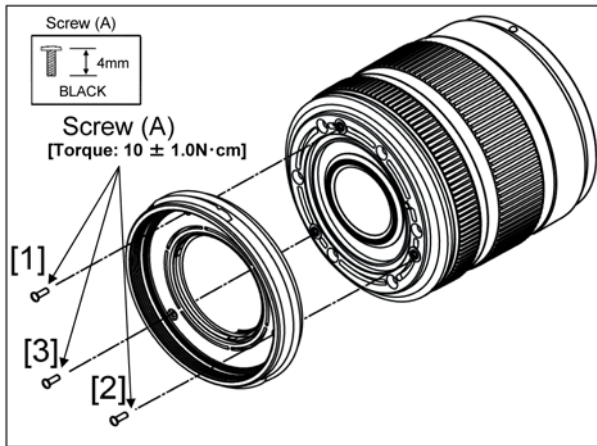

11.2.2.2. Installation of the Decoration Ring

1. Use the Name Ring fixture (RFKZ0507)
2. Use new Decoration ring. (Do not use the one which is removed.)

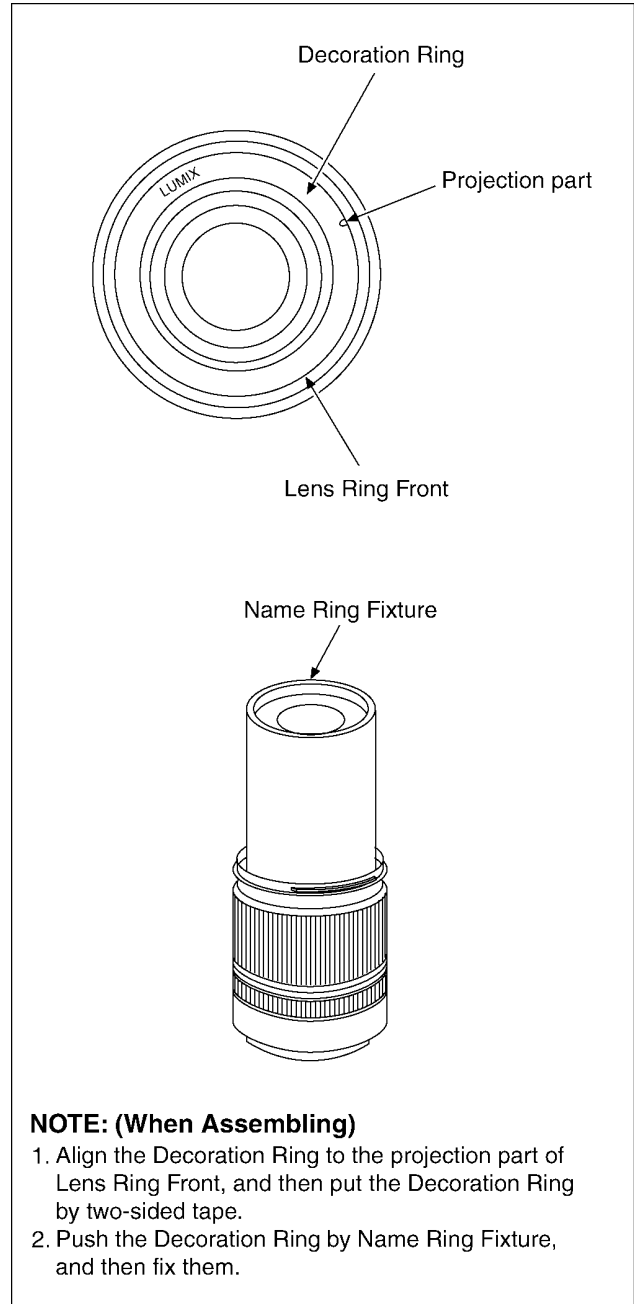

11.3. General description (Lens cleaning: Interchangeable Lens/H-FS045200)

When there is a dust/dirt inside surface of the 1st lens frame unit and/or subject side surface of the 2nd lens frame unit, remove it by referring the following procedures.

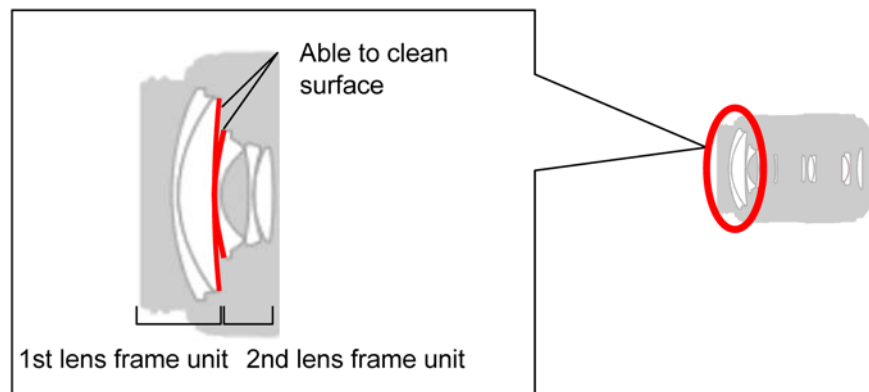

CAUTION

***DO NOT REMOVE 1st LENS FRAME UNIT OTHER THAN INSIDE OF SPECIFIED CLEAN LEVEL.
(Specified clean level: Less than class 10,000 (Federal Standard 209D))**

Important:

1. When removing the 1st lens frame unit, it has to be proceed inside of satisfied clean level.
(Less than class 10,000 (Federal Standard 209D))
As for clean box, refer to the "8.2. Clean Box", in details.
2. When tighten the screws (A), use torque driver (RFKZ0456) with specified torque.
3. To keep the Lens performance, use only the 1st lens frame unit which was fitted as it was.
Therefore, the 1st lens frame unit is not supplied as spare parts.
Also do not exchange the 1st lens unit taking from others.

11.3.1. Disassembly procedure

Important:

It must be performed inside of satisfied clean level.
(Satisfied clean level: Less than class 10,000 (Federal Standard 209D))

11.3.1.1. Removal of the Decoration Ring

1. Decoration ring is stuck on the 1st lens frame unit.
2. Put the sheet so that the lens glass is fully covered.
3. Insert the needle to Gap (A) (between the decoration ring and lens glass), and peel off the decoration ring gently.

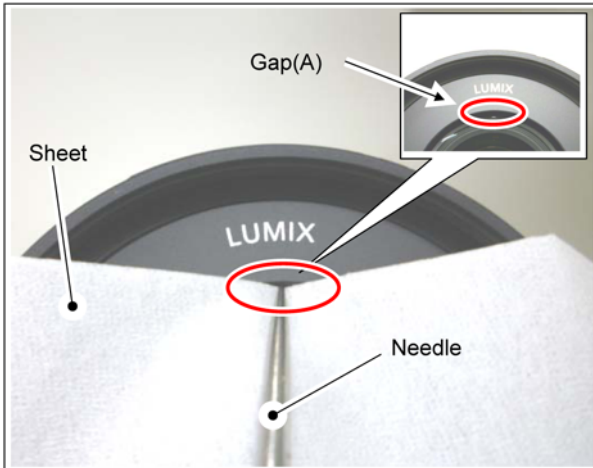

11.3.1.2. Removal of the 1st Lens Frame Unit

Important:

When removing the 1st lens frame unit, it has to be proceed inside of specified clean level.
(Less than class 10,000 Federal Standard 209D)

1. Remove the 3 screws (A) and then remove the 1st lens frame unit.

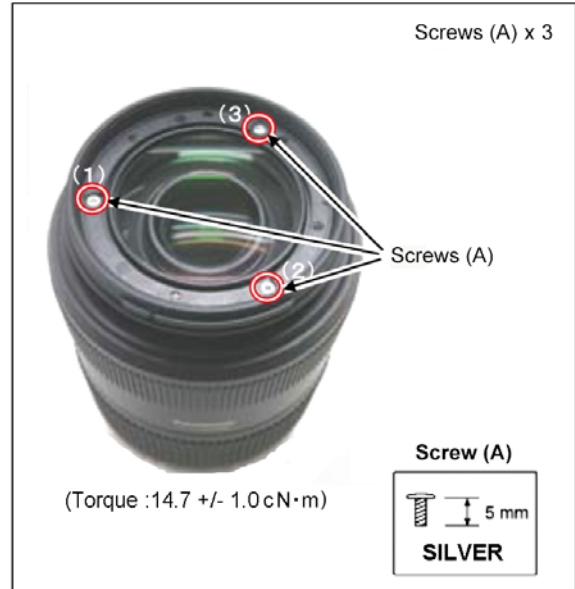

11.3.1.3. Removal of a dust /dirt

1. Blow off the dust on the Lens glass surface with the Blower, gently. (Do not Blow too strongly.)
2. Although after blowing, the dust/dirt does not blow off, wipe out the dirt on the lens glass surface with Lens cleaning KIT. (VFK1900BK)
(Consult the Instruction sheet which is included in the Lens cleaning KIT in details.)

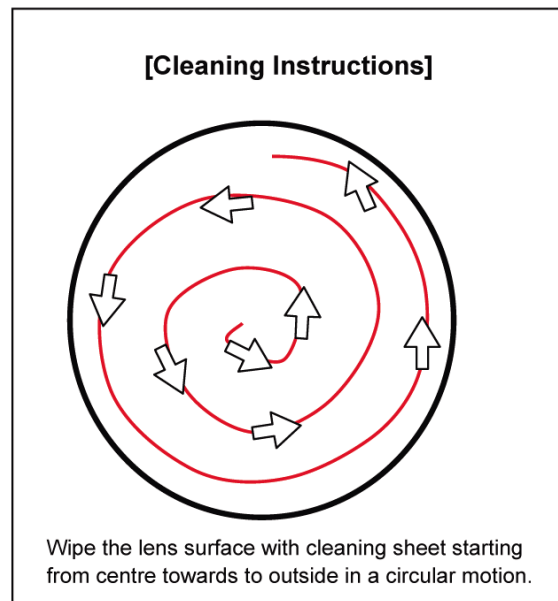

11.3.2. Assembly procedure

11.3.2.1. Installation of the 1st lens frame unit

1. Install the 1st lens frame unit onto the lens unit to meet the through hole (A) with projection (A).

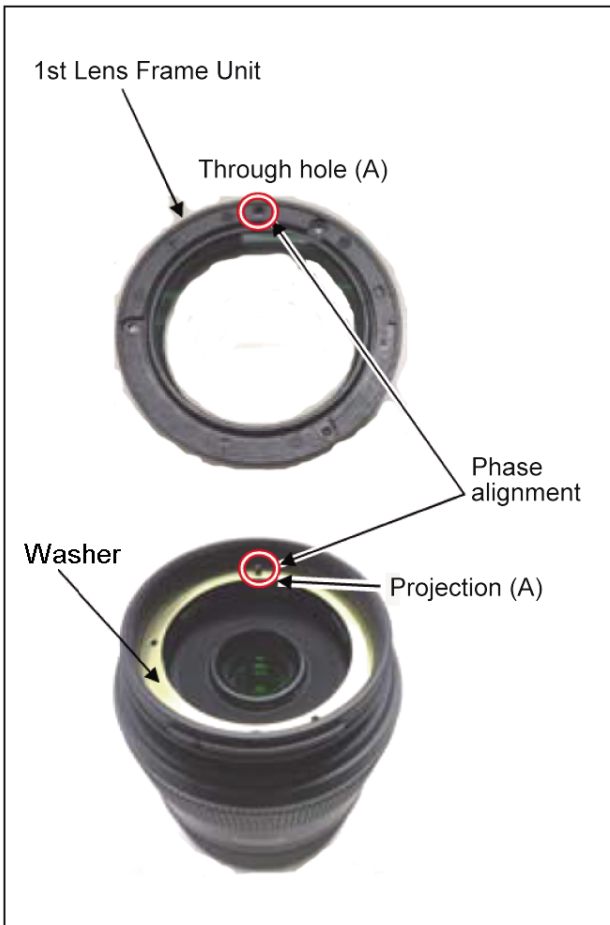

2. Tighten the screw (A) in number order ((1),(2),(3)) by using the torque driver (RFKZ0456) with specified torque. (Torque :14.7 +/- 1.0cN·m)

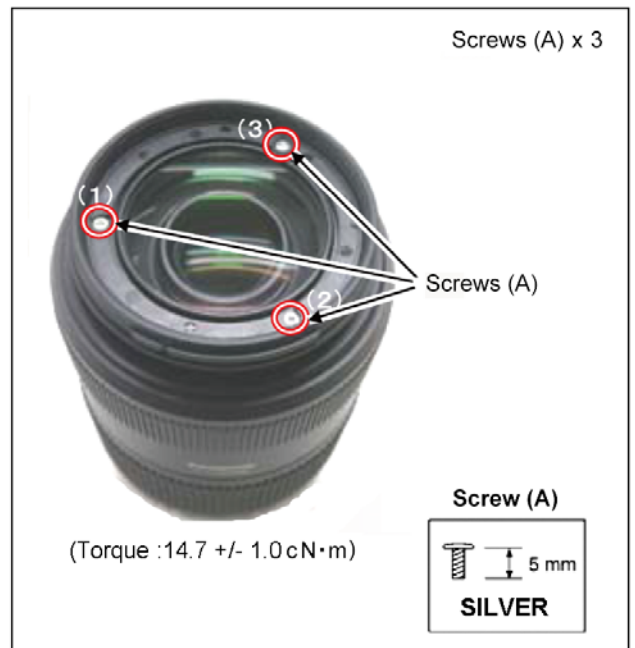

11.3.2.2. Installation of the Decoration Ring

1. Use the Name Ring fixture (RFKZ0507)
2. Use new Decoration ring.
(Do not use the one which is removed.)

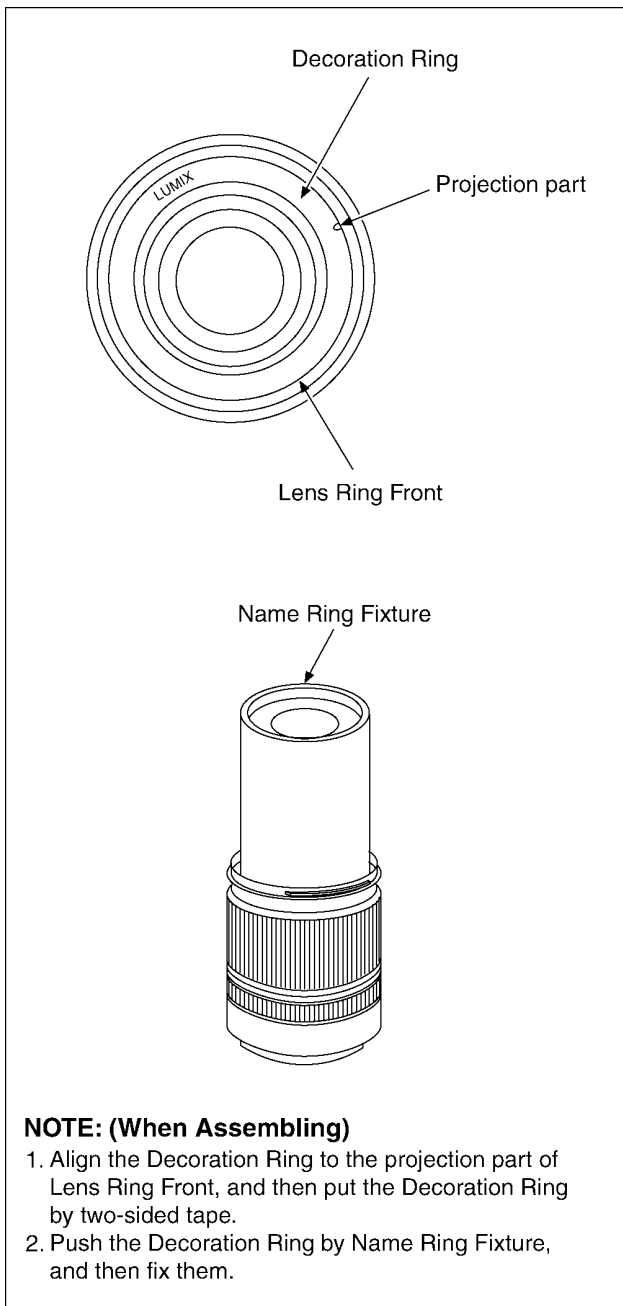

NOTE: (When Assembling)

1. Align the Decoration Ring to the projection part of Lens Ring Front, and then put the Decoration Ring by two-sided tape.
2. Push the Decoration Ring by Name Ring Fixture, and then fix them.

Service Manual

Diagrams and Replacement Parts List

Digital Camera/Lens Kit/Body

Model No.

DMC-G2KPP	DMC-G2KGT	DMC-G2WGH	DMC-G2GN
DMC-G2KEB	DMC-G2KGK	DMC-G2WGN	
DMC-G2KEC	DMC-G2KGN	DMC-G2EB	
DMC-G2KEG	DMC-G2WEB	DMC-G2EC	
DMC-G2KGC	DMC-G2WEC	DMC-G2EG	
DMC-G2KGD	DMC-G2WEG	DMC-G2GC	
DMC-G2KGH	DMC-G2WGC	DMC-G2GH	

Vol. 1

Colour

[DMC-G2K]

(K).....Black Type

(R).....Red Type (except GD/GT/GN)

(A).....Blue Type (except GD/GT/GN)

[DMC-G2W]

(K).....Black Type

(R).....Red Type (except GC/GH/GN)

(A).....Blue Type (except GC/GH/GN)

[DMC-G2]

(K).....Black Type

Table of contents

S1. About Indication of The Schematic Diagram S-1

S1.1. Important Safety Notice..... S-1

S2. Block Diagram..... S-2

S2.1. Overall Block Diagram S-2

S3. Schematic Diagram..... S-3

S3.1. Interconnection Diagram S-3

S3.2. Remote Schematic Diagram S-4

S3.3. Hinge SW Schematic Diagram..... S-4

S4. Print Circuit Board S-5

S4.1. Remote P.C.B..... S-5

S4.2. Hinge SW P.C.B. S-5

S5. Replacement Parts List..... S-7

S6. Exploded View S-13

S6.1. Frame and Casing Section..... S-13

S6.2. Camera Lens Section (1) S-14

S6.3. Camera Lens Section (2) S-15

S6.4. Packing Parts and Accessories Section (1) S-16

S6.5. Packing Parts and Accessories Section (2) S-17

S6.6. Packing Parts and Accessories Section (3) S-18

S1. About Indication of The Schematic Diagram

S1.1. Important Safety Notice

COMPONENTS IDENTIFIED WITH THE MARK \triangle HAVE THE SPECIAL CHARACTERISTICS FOR SAFETY. WHEN REPLACING ANY OF THESE COMPONENTS USE ONLY THE SAME TYPE.

1. Although reference number of the parts is indicated on the P.C.B. drawing and/or schematic diagrams, it is NOT mounted on the P.C.B. when it is displayed with "\$" mark.
2. It is only the "Test Round" and no terminal (Pin) is available on the P.C.B. when the TP (Test Point) indicated as "●" mark.
3. The voltage being indicated on the schematic diagram is measured in "Standard-Playback" mode when there is no specify mode is mentioned.
4. Although the voltage and waveform available on here is measured with standard frame, it may be differ from actual measurement due to modification of circuit and so on.
5. The voltage being indicated here may be include observational-error (deviation) due to internal-resistance and/or reactance of equipment. Therefore, handle the value indicated on here as reference.
6. Use the parts number indicated on the Replacement Parts List .
7. Indication on Schematic diagrams:

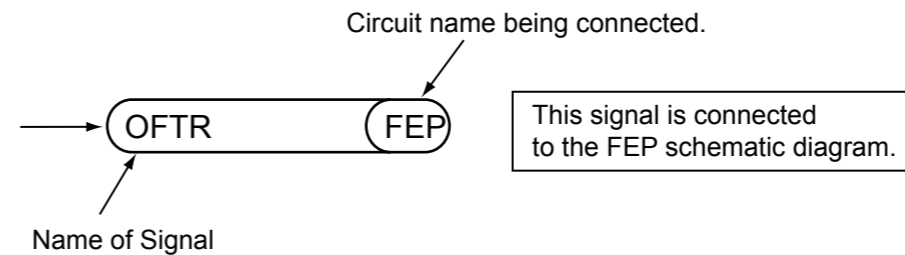

S2. Block Diagram

S2.1. Overall Block Diagram

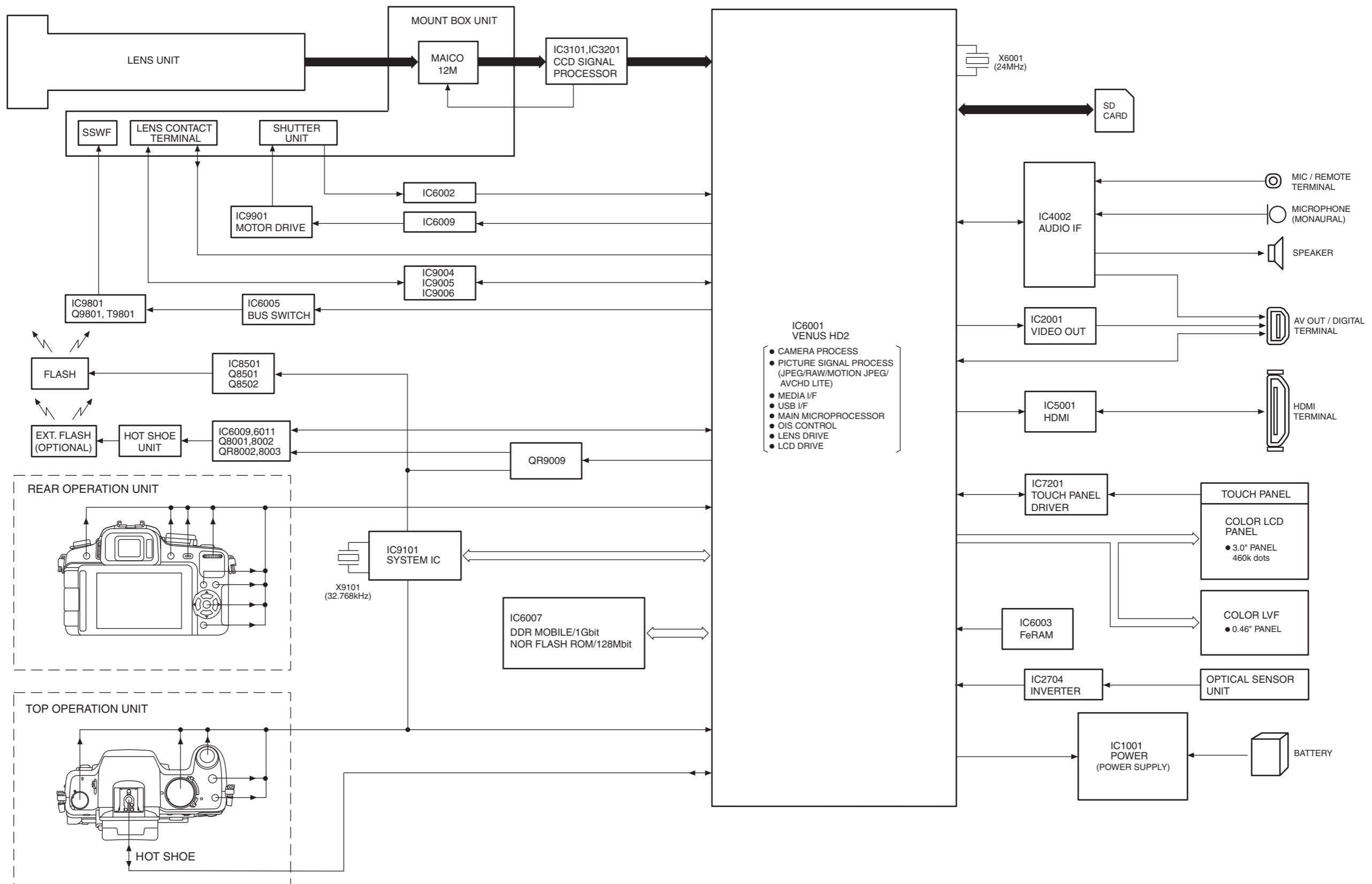

S3.2. Remote Schematic Diagram / S3.3. Hinge SW Schematic Diagram

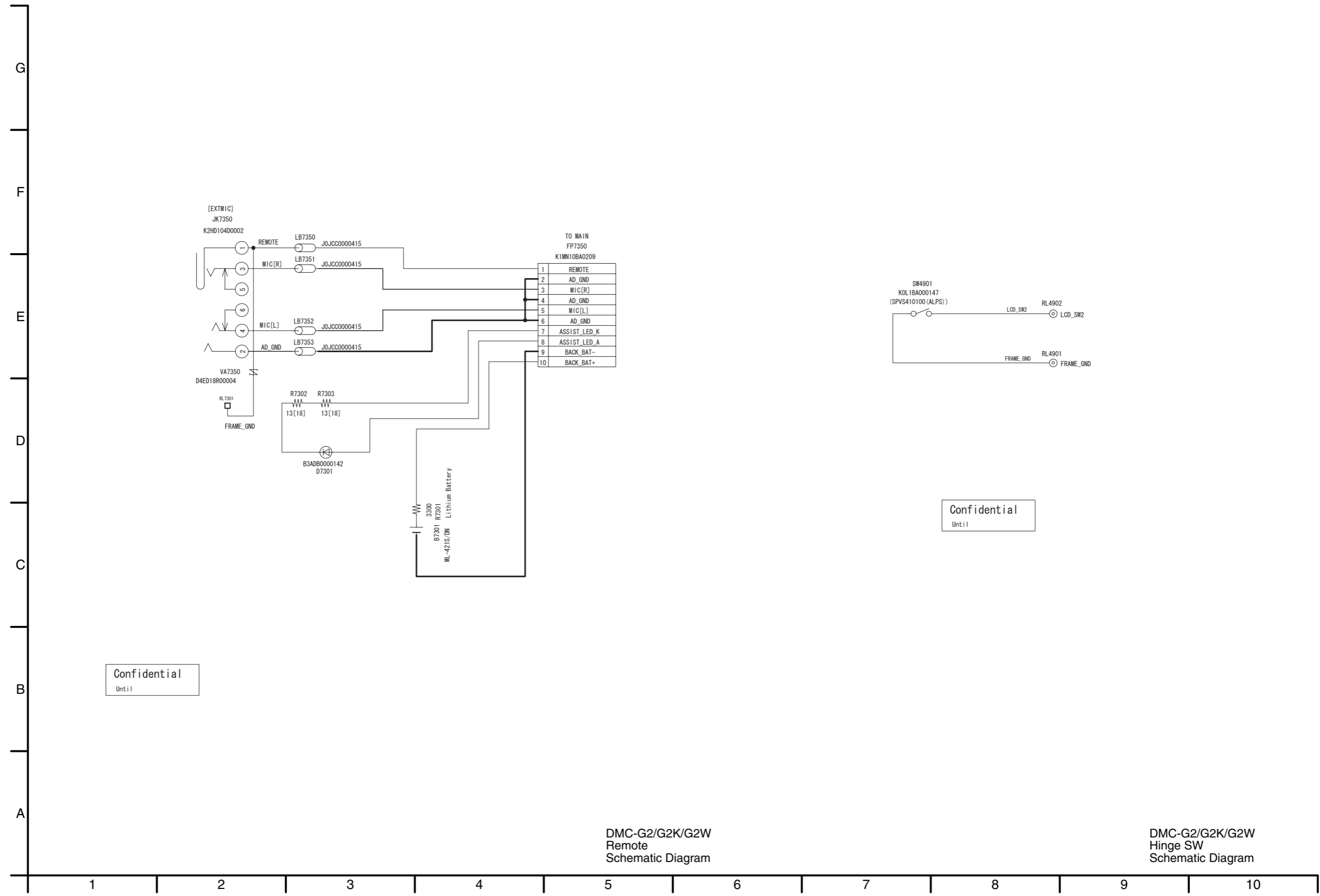

DMC-G2/G2K/G2W Remote Schematic Diagram

DMC-G2/G2K/G2W Hinge SW Schematic Diagram

S4. Print Circuit Board

S4.1. Remote P.C.B. / S4.2. Hinge SW P.C.B.

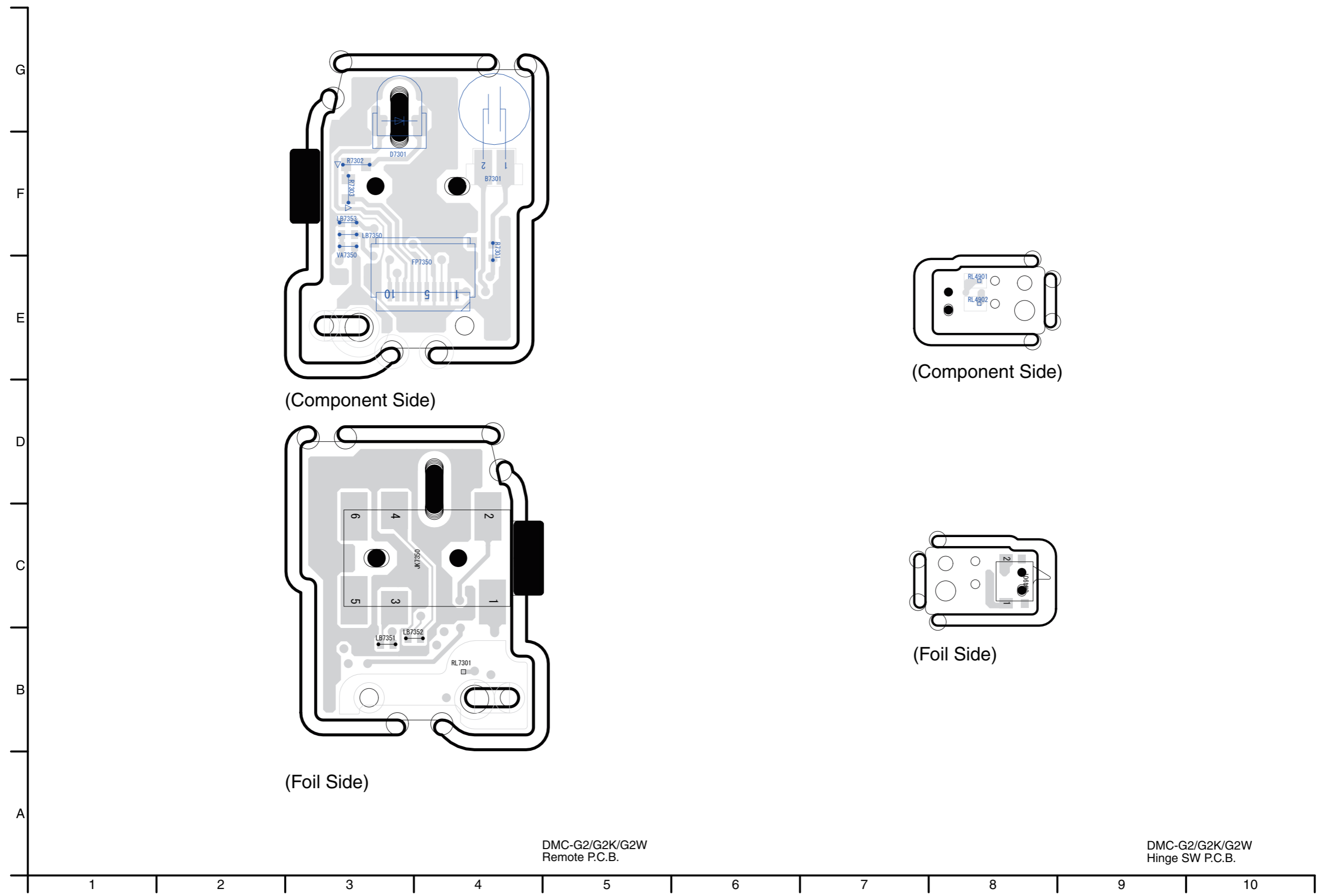

DMC-G2/G2K/G2W
Remote P.C.B.

DMC-G2/G2K/G2W
Hinge SW P.C.B.

S5. Replacement Parts List

- Note: 1.* Be sure to make your orders of replacement parts according to this list.
2. IMPORTANT SAFETY NOTICE
Components identified with the mark \triangle have the special characteristics for safety.
When replacing any of these components, use only the same type.
3. Unless otherwise specified,
All resistors are in OHMS, K=1,000 OHMS. All capacitors are in MICRO-FARADS (uf), P=uuF.
4. The marking (RTL) indicates the retention time is limited for this item. After the discontinuation of this assembly in production, it will no longer be available.
5. Supply of CD-ROM, in accordance with license protection, is allowable as replacement parts only for customers who accidentally damaged or lost their own.

E.S.D. standards for Electrostatically Sensitive Devices, refer to PREVENTION OF ELECTROSTATIC DISCHARGE (ESD) TO ELECTROSTATICALLY SENSITIVE (ES) DEVICES section.

<ABOUT LENS MAIN BLOCK UNIT "(Ref.208 and Ref.308)>

+ .In case of the "LENS MAIN BLOCK UNIT" (Ref.208 and Ref.308) defects, contact to the service department of sales company.

<DEFINITION OF PARTS SUPPLIER>

1. Parts marked with [ENERGY] in the remarks column are supplied from Panasonic Corporation
Energy Company.
2. Parts marked with [SPC] in the remarks column are supplied from AVC-CSC-SPC.

Ref.No.	Part No.	Part Name & Description	Pcs	Remarks
1	VEP56106B	MAIN P.C.B.	1	(RTL) E.S.D.(EG/EC/EB)
1	VEP56106A	MAIN P.C.B.	1	(RTL) E.S.D. (GC/GH/GT/GK/GN/GD/PP)
2	K0RE01300016	TOP OPERATION (L) UNIT	1	
3	VXQ1913	MOUNT BOX UNIT	1	[SPC]
4	ML-421S/DN	BUTTON BATTERY	1	(B7301)[ENERGY]
5	VEP58115A	REMOTE P.C.B.	1	(RTL) E.S.D.
6	VYK4D56	FRONT CASE UNIT	1	(-K)
6	VYK4D57	FRONT CASE UNIT	1	(-A)
6	VYK4D58	FRONT CASE UNIT	1	(-R)
7	VGK3629	GRIP PIECE PRONT	1	
8	VGQ0L42	AF LIGHT CASE	1	
9	VGQ0L43	REMOTE HOLDER	1	
10	VGQ0L44	JACK HOLDER	1	
11	VKF4699	REMOTE COVER	1	(-K)
11	VKF4705	REMOTE COVER	1	(-R)
11	VKF4706	REMOTE COVER	1	(-A)
12	VKF4700	JACK COVER	1	(-K)
12	VKF4707	JACK COVER	1	(-R)
12	VKF4708	JACK COVER	1	(-A)
13	VMP9628	MOUNT EARTH PLATE	1	
14	VMP9629	SIDE FRAME R	1	
15	VMP9685	FRONT EARTH PLATE	1	
16	VWJ2177	REMOTE FPC	1	
17	VEK0M97	FLASH UNIT	1	
18	VYK4D92	TOP CASE (R) UNIT	1	
18-1	VEK0P89	HOT SHOE UNIT	1	
19	VKM8413	FLASH CASE TOP	1	
20	VMC2111	SHOE SPRING	1	
21	VYQ5668	EYE CUP UNIT	1	
22	VKM8424	HINGE ARM COVER TOP	1	(-K)
22	VKM8598	HINGE ARM COVER TOP	1	(-R)
22	VKM8599	HINGE ARM COVER TOP	1	(-A)
23	VKM8425	HINGE ARM COVER BOTTOM	1	(-K)
23	VKM8600	HINGE ARM COVER BOTTOM	1	(-R)
23	VKM8601	HINGE ARM COVER BOTTOM	1	(-A)
24	VMP9634	HINGE PLATE	1	
25	K0RC01100004	REAR OPERATION UNIT	1	
26	L2CH00000029	OPTICAL SENSOR	1	
27	VEE1F12	HINGE SW HARNESS	1	
28	VEP58114A	HINGE SW P.C.B.	1	(RTL)
29	VYK4D59	REAR CASE UNIT	1	(-K)
29	VYK4D60	REAR CASE UNIT	1	(-A)
29	VYK4D61	REAR CASE UNIT	1	(-R)
30	VGQ0L47	GRIP PIECE REAR	1	
31	VGQ0L64	LCD LOCK PIECE	1	
32	VGU0D14	PLAY AF/AE LOCK BUTTON	1	
33	VGU0D47	LVF/LCD BUTTON	1	
34	VGU0F99	REAR OP BUTTON	1	
35	VGU0G00	LCD LOCK LEVER	1	
36	VMB4373	LCD LOCK SPRING	1	
37	VMP9632	EYE PLATE	1	
38	VMP9633	REAR EARTH PLATE	1	
39	VMP9638	HINGE EARTH PLATE	1	
40	VWJ2178	EYE SENSOR FPC	1	
41	VEK0Q33	LCD UNIT	1	
42	VEP59079A	LCD IF P.C.B.	1	(RTL) E.S.D.
43	VGQ0N91	LCD BLBEZEL SHEET	1	
44	VKM8422	LCD CASE TOP	1	(-K)
44	VKM8602	LCD CASE TOP	1	(-R)
44	VKM8603	LCD CASE TOP	1	(-A)
45	VYK4D62	LCD CASE BOTTOM UNIT	1	(-K)
45	VYK4D63	LCD CASE BOTTOM UNIT	1	(-A)
45	VYK4D64	LCD CASE BOTTOM UNIT	1	(-R)
46	VYK4C20	LCD HINGE UNIT	1	(-K)
46	VYK4C21	LCD HINGE UNIT	1	(-R)
46	VYK4C22	LCD HINGE UNIT	1	(-A)
47	VYQ5594	STRAP (R) UNIT	1	
48	VYQ5595	STRAP (L) UNIT	1	
49	F2AZZ2310002	E.CAPACITOR	1	(C8510)
50	K4ZZ04000050	BATTERY CATCHER	1	(P1001)
51	L0AA01A00052	SPEAKER	1	
52	VEP51027A	POWER FLASH P.C.B.	1	(RTL) E.S.D.
53	VGQ0L46	FLASH PCB COVER	1	
54	VGQ0F84	SPEAKER CUSHION	1	
55	VGU0D11	BATTERY LOCK KNOB	1	

Ref.No.	Part No.	Part Name & Description	Pcs	Remarks
56	VYF3349	BATTERY DOOR UNIT	1	(-K)
56	VYF3350	BATTERY DOOR UNIT	1	(-A)
56	VYF3351	BATTERY DOOR UNIT	1	(-R)
57	VKF4702	DC COVER	1	(-K)
57	VKF4711	DC COVER	1	(-R)
57	VKF4712	DC COVER	1	(-A)
58	VKM8426	BATTERY CASE	1	
59	VMA0X26	TRIPOD FRAME	1	
60	VMB4199	BATTERY LOCK SPRING	1	
61	VMB4201	BATTERY SPRING	1	
62	VMB4401	BATT DOOR SPRING	1	
63	VMB4370	CON EARTH SPRING	1	
64	VMP9630	BATTERY PLATE	1	
65	VMP9635	BATTERY PLATE L	1	
66	VMP9636	BATTERY LOCK CAP	1	
67	VMS8080	BATTERY DOOR SHAFT	1	
68	VWJ2174	MAIN-POW FPC	1	
69	VYQ5680	LVF UNIT	1	[SPC]
69-1	VG6P235	LVF PANEL	1	[SPC]
69-2	VGQ0A40	LVF COVER	1	[SPC]
71	L5EDDXL00001	LVF MODULE	1	[SPC]
72	VXQ1936	LVF FPC (1)	1	[SPC]
72-1	VGQ0P36	LVF FIX TAPE	1	[SPC]
B1	VHD2149	SCREW	1	
B2	VHD2149	SCREW	1	
B3	VHD2149	SCREW	1	
B4	VHD2149	SCREW	1	
B5	VHD2149	SCREW	1	
B6	VHD2149	SCREW	1	
B7	VHD2149	SCREW	1	
B8	VHD2149	SCREW	1	
B9	VHD2149	SCREW	1	
B10	VHD2149	SCREW	1	
B11	VHD2149	SCREW	1	
B12	VHD2149	SCREW	1	
B13	VHD2178	SCREW	1	
B14	VHD2178	SCREW	1	
B15	VHD2178	SCREW	1	
B16	VHD2178	SCREW	1	
B17	VHD2178	SCREW	1	
B18	VHD2227	SCREW	1	
B19	VHD2227	SCREW	1	
B20	VHD2227	SCREW	1	
B21	VHD2227	SCREW	1	
B22	VHD2228	SCREW	1	
B23	XQN16+B2FN	SCREW	1	
B24	XQN16+B2FN	SCREW	1	
B25	XQN16+B2FN	SCREW	1	
B26	XQN16+BJ4FN	SCREW	1	
B27	XQN16+BJ4FN	SCREW	1	
B28	XQN16+BJ4FN	SCREW	1	
B29	XQN16+BJ4FN	SCREW	1	
B30	XQN16+BJ5FJK	SCREW	1	
B31	XQN16+BJ5FJK	SCREW	1	
B32	VHD2179	SCREW	1	
B33	VHD2179	SCREW	1	
B34	XQN16+B5FN	SCREW	1	
B35	XQN16+B5FN	SCREW	1	
B36	XQN16+BJ6FN	SCREW	1	
B37	XQN16+BJ6FN	SCREW	1	
B38	VHD1996	SCREW	1	
B39	XQN16+BJ11FN	SCREW	1	
B40	XQN16+BJ11FN	SCREW	1	
B41	XQN16+BJ4FN	SCREW	1	
B42	XQN16+BJ4FN	SCREW	1	
B43	XQN16+BJ4FN	SCREW	1	
B44	VHD2163-A	SCREW	1	
B45	XQN16+B2FN	SCREW	1	
B46	XQN16+BJ4FN	SCREW	1	
B47	XQN16+BJ4FN	SCREW	1	
B48	XQN16+BJ4FN	SCREW	1	
B49	XQN16+BJ4FN	SCREW	1	
B50	XQN16+BJ4FN	SCREW	1	
B51	XQN16+BJ4FN	SCREW	1	

Ref.No.	Part No.	Part Name & Description	Pcs	Remarks
400	XZB05X06C03Z	CAMERA BAG	1	
△ 402	DE-A49BA/SX	BATTERY CHARGER	1	KPP
△ 402	DE-A49DB/SX	BATTERY CHARGER	1	KGTK
△ 402	DE-A49EA/SX	BATTERY CHARGER	1	KGK
△ 402	DE-A49FB/SX	BATTERY CHARGER	1	KGDK
△ 402	DE-A49CB/SX	BATTERY CHARGER	1	KEG,KEC,KEB,KGC,KGH,KGN
△ 403	----	BATTERY PACK	1	(Not supplied)
404	K1HA08AD0003	USB CABLE W/PLUG	1	
405	K1HA08CD00020	AV CABLE W/PLUG	1	
406	VFC4538	SHOULDER STRAP	1	
407	VFF0616-S	CD-ROM	1	KGK[SPC] See "Notes"
407	VFF0615-S	CD-ROM	1	[SPC](Except "KGK") See "Notes"
408	VPK4429	PACKING CASE	1	KPP
408	VPK4430	PACKING CASE	1	KEG,KEC,KEB,KGC,KGH,KGT, KGN,KGD
408	VPK4430	PACKING CASE	1	KGH
408	VPK4431	PACKING CASE	1	KGK
409	VQL2F42	COLOR LABEL	1	KGKR
409	VQL2F41	COLOR LABEL	1	KGKA
409	VQL1Z66	COLOR LABEL	1	KPPR
409	VQL1Z65	COLOR LABEL	1	KPPA
409	VQL1Z69	COLOR LABEL	1	KEGR,KECR,KEBR,KGCR,KGHR
409	VQL1Z68	COLOR LABEL	1	KEGA,KECA,KEBA,KGCA,KGHA
411	VPF1132	BAG, POLYETHYLENE	1	KPP,KEG,KEC,KGC
411	VPF1100	BAG, POLYETHYLENE	1	KEB,KGH,KGT,KGK,KGN,KGD
412	VQT2S53	O/I SOFTWARE	1	KPP (ENGLISH/CANADIAN-FRENCH/ SPANISH/PORTUGUESE)
412	VQT2S58	O/I SOFTWARE	1	KGT (ENGLISH/ CHINESE(TRADITIONAL)/ RUSSIAN/ARABIC)
412	VQT2S59	O/I SOFTWARE	1	KGK (CHINESE(TRADITIONAL))
412	VQT2S60	O/I SOFTWARE	1	KGD (KOREAN)
412	VQT2S54	O/I SOFTWARE	1	KEG (GERMAN/FRENCH/ITALIAN/ DUTCH)
412	VQT2S55	O/I SOFTWARE	1	KEC (SPANISH/PORTUGUESE/ SWEDISH/DANISH)
412	VQT2S56	O/I SOFTWARE	1	KEB,KGN (ENGLISH)
412	VQT2S57	O/I SOFTWARE	1	KGC,KGH (ENGLISH/ CHINESE(TRADITIONAL)/ RUSSIAN/ARABIC)
△ 414	VQT2S30	INSTRUCTION BOOK	1	KPP (ENGLISH)
△ 414	VQT2S31	INSTRUCTION BOOK	1	KPP (CANADIAN-FRENCH)
△ 414	VQT2S32	INSTRUCTION BOOK	1	KPP (SPANISH)
△ 414	VQT2S33	INSTRUCTION BOOK	1	KPP (PORTUGUESE)
△ 414	VQT2S47	INSTRUCTION BOOK	1	KGT (CHINESE(TRADITIONAL))
△ 414	VQT2S48	INSTRUCTION BOOK	1	KGK (CHINESE(SIMPLIFIED))
△ 414	VQT2S50	INSTRUCTION BOOK	1	KGD (KOREAN)
△ 414	VQT2S34	INSTRUCTION BOOK	1	KEG (GERMAN)
△ 414	VQT2S35	INSTRUCTION BOOK	1	KEG (FRENCH)
△ 414	VQT2S36	INSTRUCTION BOOK	1	KEG (ITALIAN)
△ 414	VQT2S37	INSTRUCTION BOOK	1	KEG (DUTCH)
△ 414	VQT2S38	INSTRUCTION BOOK	1	KEC (SPANISH)
△ 414	VQT2S39	INSTRUCTION BOOK	1	KEC (PORTUGUESE)

Ref.No.	Part No.	Part Name & Description	Pcs	Remarks
△ 414	VQT2S40	INSTRUCTION BOOK	1	KEC (SWEDISH)
△ 414	VQT2S41	INSTRUCTION BOOK	1	KEC (DANISH)
△ 414	VQT2S42	INSTRUCTION BOOK	1	KEB (ENGLISH)
△ 414	VQT2S43	INSTRUCTION BOOK	1	KGC,KGH (ENGLISH)
△ 414	VQT2S44	INSTRUCTION BOOK	1	KGC,KGH (CHINESE(TRADITIONAL))
△ 414	VQT2S45	INSTRUCTION BOOK	1	KGCC (RUSSIAN)
△ 414	VQT2S46	INSTRUCTION BOOK	1	KGK (ARABIC)
△ 414	VQT2S49	INSTRUCTION BOOK	1	KGN (ENGLISH)
416	VPN7027	PAD A	1	
417	VPN7028	PAD B	1	
418	VPN7029	PAD C	1	(G2K)
421	VVF1321	LENS BAG (POLI)	1	(G2K)(H-FS014042)[SPC]
422	VYC1009	LENS-HOOD-UNIT	1	(G2K)[SPC]
423	VFC4456	LENS BAG	1	(G2K)[SPC]
434	VGQ0C14	TOUCH PEN	1	
435	VKF4385	BODY CAP	1	(G2K)[SPC]
443	VFC4315	LENS CAP REAR	1	(G2K)(H-FS014042)[SPC]
444	VYF3201	LENS CAP FRONT	1	(G2K)(H-FS014042)[SPC]
447	VQL2F42	COLOR LABEL	1	KGKR
447	VQL2F41	COLOR LABEL	1	KGKA
447	VQL1Z66	COLOR LABEL	1	KPPR
447	VQL1Z65	COLOR LABEL	1	KPPA
447	VQL1Z69	COLOR LABEL	1	KEGR,KECR,KEBR,KGCR,KGHR
447	VQL1Z68	COLOR LABEL	1	KEGA,KECA,KEBA,KGCA,KGHA
448	VQL2F42	COLOR LABEL	1	KGKR
448	VQL2F41	COLOR LABEL	1	KGKA
448	VQL1Z66	COLOR LABEL	1	KPPR
448	VQL1Z65	COLOR LABEL	1	KPPA
448	VQL1Z69	COLOR LABEL	1	KEGR,KECR,KEBR,KGCR,KGHR
448	VQL1Z68	COLOR LABEL	1	KEGA,KECA,KEBA,KGCA,KGHA
449	VPQ0276	AIR-CAP SHEET	1	(G2K)
△ 469	K2CT39A00002	AC CORD W/PLUG	1	KEB,KGC,KGH
△ 470	K2CR29A00001	AC CORD W/PLUG	1	KGD
△ 470	K2CQ29A00002	AC CORD W/PLUG	1	KEG,KEC,KGC
△ 471	K2CJ29A00002	AC CORD W/PLUG	1	KGN
△ 472	K2CA2EA00002	AC CORD W/PLUG	1	KPP
△ 472	K2CA2YY00070	AC CORD W/PLUG	1	KGK
△ 472	K2CA29A00021	AC CORD W/PLUG	1	KGT

Ref.No.	Part No.	Part Name & Description	Pcs	Remarks
500	XZB05X06C03Z	CAMERA BAG	1	
△ 502	DE-A49CB/SX	BATTERY CHARGER	1	(G2W)
△ 503	-----	BATTERY PACK	1	(Not supplied)
504	K1HA08AD0003	USB CABLE W/PLUG	1	
505	K1HA08CD0020	AV CABLE W/PLUG	1	
506	VFC4538	SHOULDER STRAP	1	
507	VFF0615-S	CD-ROM	1	(G2W)[SPC] See "Notes"
508	VPK4433	PACKING CASE	1	WEGK,WGCK,WGHK,WGNK
508	VPK4433	PACKING CASE	1	WEGRA,WECR,WEBR
509	VQL1269	COLOR LABEL	1	WEGA,WECA,WEBA
509	VQL1268	COLOR LABEL	1	WEGA,WECA,WEBA
511	VPF1132	BAG, POLYETHYLENE	1	WEG,WEC,WGC
511	VPF1100	BAG, POLYETHYLENE	1	WEB,WGH,WGN
512	VQT2S54	O/I SOFTWARE	1	WEG (GERMAN/FRENCH/ITALIAN/ DUTCH)
512	VQT2S55	O/I SOFTWARE	1	WEC (SPANISH/PORTUGUESE/ SWEDISH/DANISH)
512	VQT2S56	O/I SOFTWARE	1	WGC,WGH (ENGLISH)
512	VQT2S57	O/I SOFTWARE	1	WGC,WGH (ENGLISH/ CHINESE(TRADITIONAL)/ RUSSIAN/ARABIC)
△ 514	VQT2S34	INSTRUCTION BOOK	1	WEG (GERMAN)
△ 514	VQT2S35	INSTRUCTION BOOK	1	WEG (FRENCH)
△ 514	VQT2S36	INSTRUCTION BOOK	1	WEG (ITALIAN)
△ 514	VQT2S37	INSTRUCTION BOOK	1	WEG (DUTCH)
△ 514	VQT2S38	INSTRUCTION BOOK	1	WEC (SPANISH)
△ 514	VQT2S39	INSTRUCTION BOOK	1	WEC (PORTUGUESE)
△ 514	VQT2S40	INSTRUCTION BOOK	1	WEC (SWEDISH)
△ 514	VQT2S41	INSTRUCTION BOOK	1	WEC (DANISH)
△ 514	VQT2S42	INSTRUCTION BOOK	1	WEB (ENGLISH)
△ 514	VQT2S43	INSTRUCTION BOOK	1	WGC,WGH (ENGLISH)
△ 514	VQT2S44	INSTRUCTION BOOK	1	WGC,WGH (CHINESE(TRADITIONAL))
△ 514	VQT2S45	INSTRUCTION BOOK	1	WGC (RUSSIAN)
△ 514	VQT2S46	INSTRUCTION BOOK	1	WGC (ARABIC)
△ 514	VQT2S49	INSTRUCTION BOOK	1	WGN (ENGLISH)
516	VPN7027	PAD A	1	
517	VPN7028	PAD B	1	
518	VPN7029	PAD C	1	(G2W)
519	VPN7031	PAD E	1	(G2W)
521	VPF1321	LENS BAG (POLI)	1	(G2W)(H-FS014042)[SPC]
522	VYC1009	LENS-HOOD-UNIT	1	(G2W)[SPC]
523	VFC4456	LENS BAG	1	(G2W)[SPC]
524	VPF1262	LENS BAG (POLI)	1	(G2W)(H-FS045200)[SPC]
532	VYC0986	LENS-HOOD-UNIT	1	(G2W)[SPC]
533	VFC4430	LENS BAG	1	(G2W)[SPC]
534	VGQ0C14	TOUCH PEN	1	
535	VKF4385	BODY CAP	1	(G2W)[SPC]
536	VPF1316	BODY BAG (POLI)	1	(G2W)[SPC]
543	VFC4315	LENS CAP REAR	1	(G2W)(H-FS014042)[SPC]
544	VYF3201	LENS CAP FRONT	1	(G2W)(H-FS014042)[SPC]
545	VFC4315	LENS CAP REAR	1	(G2W)(H-FS045200)[SPC]
546	VYF3201	LENS CAP FRONT	1	(G2W)(H-FS045200)[SPC]
547	VQL1269	COLOR LABEL	1	WEGR,WECR,WEBR
547	VQL1268	COLOR LABEL	1	WEGA,WECA,WEBA
548	VQL1269	COLOR LABEL	1	WEGR,WECR,WEBR
548	VQL1268	COLOR LABEL	1	WEGA,WECA,WEBA
549	VPQ0276	AIR-CAP SHEET	1	(G2W)

Ref.No.	Part No.	Part Name & Description	Pcs	Remarks
△ 569	K2CT39A00002	AC CORD W/PLUG	1	WEB,WGC,WGH
△ 570	K2CQ29A00002	AC CORD W/PLUG	1	WEG,WEC,WGC
△ 571	K2CJ29A00002	AC CORD W/PLUG	1	WGN
600	XZB05X06C03Z	CAMERA BAG	1	
△ 602	DE-A49CB/SX	BATTERY CHARGER	1	(G2)
△ 603	-----	BATTERY PACK	1	(Not supplied)
604	K1HA08AD0003	USB CABLE W/PLUG	1	
605	K1HA08CD0020	AV CABLE W/PLUG	1	
606	VFC4538	SHOULDER STRAP	1	
607	VFF0615-S	CD-ROM	1	(G2)[SPC] See "Notes"
608	VPK4435	PACKING CASE	1	(G2)
611	VPF1132	BAG, POLYETHYLENE	1	EGK,ECK,GCK
611	VPF1100	BAG, POLYETHYLENE	1	EBK,GHK,GNK
612	VQT2S54	O/I SOFTWARE	1	EGK (GERMAN/FRENCH/ITALIAN/ DUTCH)
612	VQT2S55	O/I SOFTWARE	1	ECK (SPANISH/PORTUGUESE/ SWEDISH/DANISH)
612	VQT2S56	O/I SOFTWARE	1	EBK,GNK (ENGLISH)
612	VQT2S57	O/I SOFTWARE	1	GCK,GHK (ENGLISH/ CHINESE(TRADITIONAL)/ RUSSIAN/ARABIC)
△ 614	VQT2S34	INSTRUCTION BOOK	1	EGK (GERMAN)
△ 614	VQT2S35	INSTRUCTION BOOK	1	EGK (FRENCH)
△ 614	VQT2S36	INSTRUCTION BOOK	1	EGK (ITALIAN)
△ 614	VQT2S37	INSTRUCTION BOOK	1	EGK (DUTCH)
△ 614	VQT2S38	INSTRUCTION BOOK	1	EGK (SPANISH)
△ 614	VQT2S39	INSTRUCTION BOOK	1	EGK (PORTUGUESE)
△ 614	VQT2S38	INSTRUCTION BOOK	1	ECK (SPANISH)
△ 614	VQT2S39	INSTRUCTION BOOK	1	ECK (PORTUGUESE)
△ 614	VQT2S40	INSTRUCTION BOOK	1	ECK (SWEDISH)
△ 614	VQT2S41	INSTRUCTION BOOK	1	ECK (DANISH)
△ 614	VQT2S42	INSTRUCTION BOOK	1	EBK (ENGLISH)
△ 614	VQT2S43	INSTRUCTION BOOK	1	GCK,GHK (ENGLISH)
△ 614	VQT2S44	INSTRUCTION BOOK	1	GCK,GHK (CHINESE(TRADITIONAL))
△ 614	VQT2S45	INSTRUCTION BOOK	1	GCK (RUSSIAN)
△ 614	VQT2S46	INSTRUCTION BOOK	1	GCK (ARABIC)
△ 614	VQT2S49	INSTRUCTION BOOK	1	GNK (ENGLISH)
616	VPN7027	PAD A	1	
617	VPN7028	PAD B	1	
618	VPN7030	PAD D	1	(G2)
634	VGQ0C14	TOUCH PEN	1	
635	VKF4385	BODY CAP	1	(G2)[SPC]
669	K2CT39A00002	AC CORD W/PLUG	1	EBK,GCK,GHK
670	K2CQ29A00002	AC CORD W/PLUG	1	EGK,ECK,GCK
671	K2CJ29A00002	AC CORD W/PLUG	1	GNK

S6. Exploded View

S6.1. Frame and Casing Section

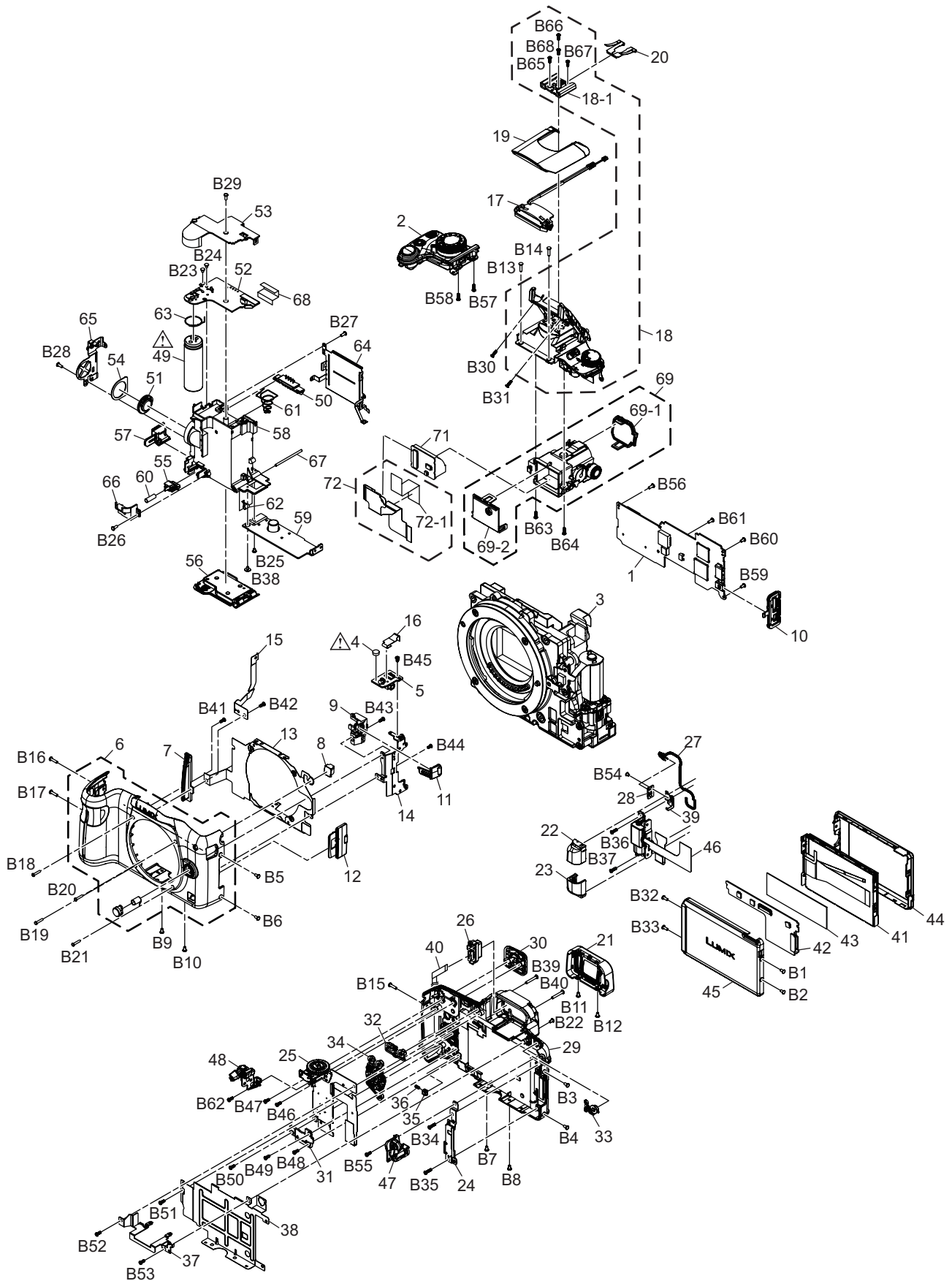

S6.2. Camera Lens Section (1)

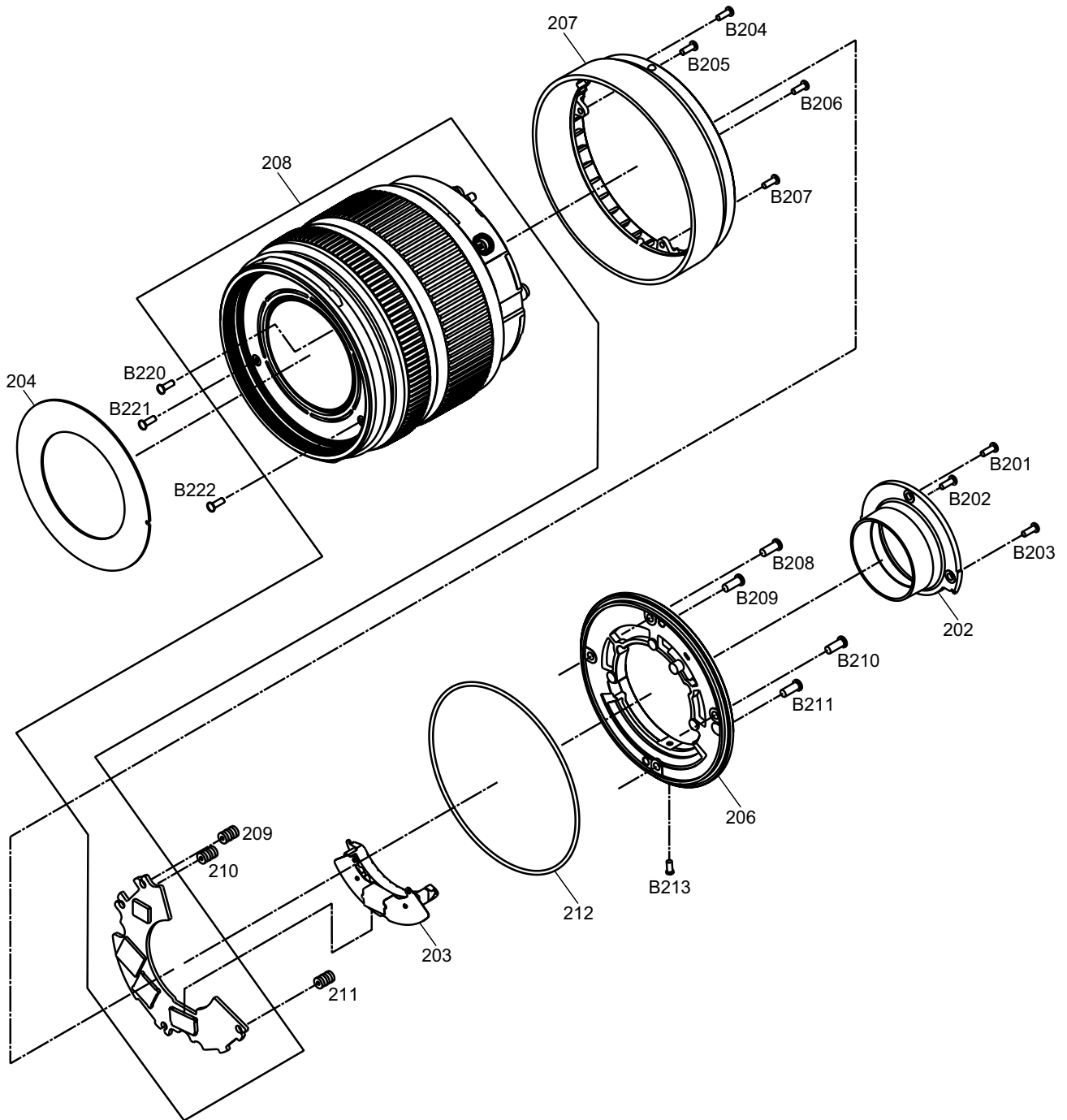

S6.3. Camera Lens Section (2)

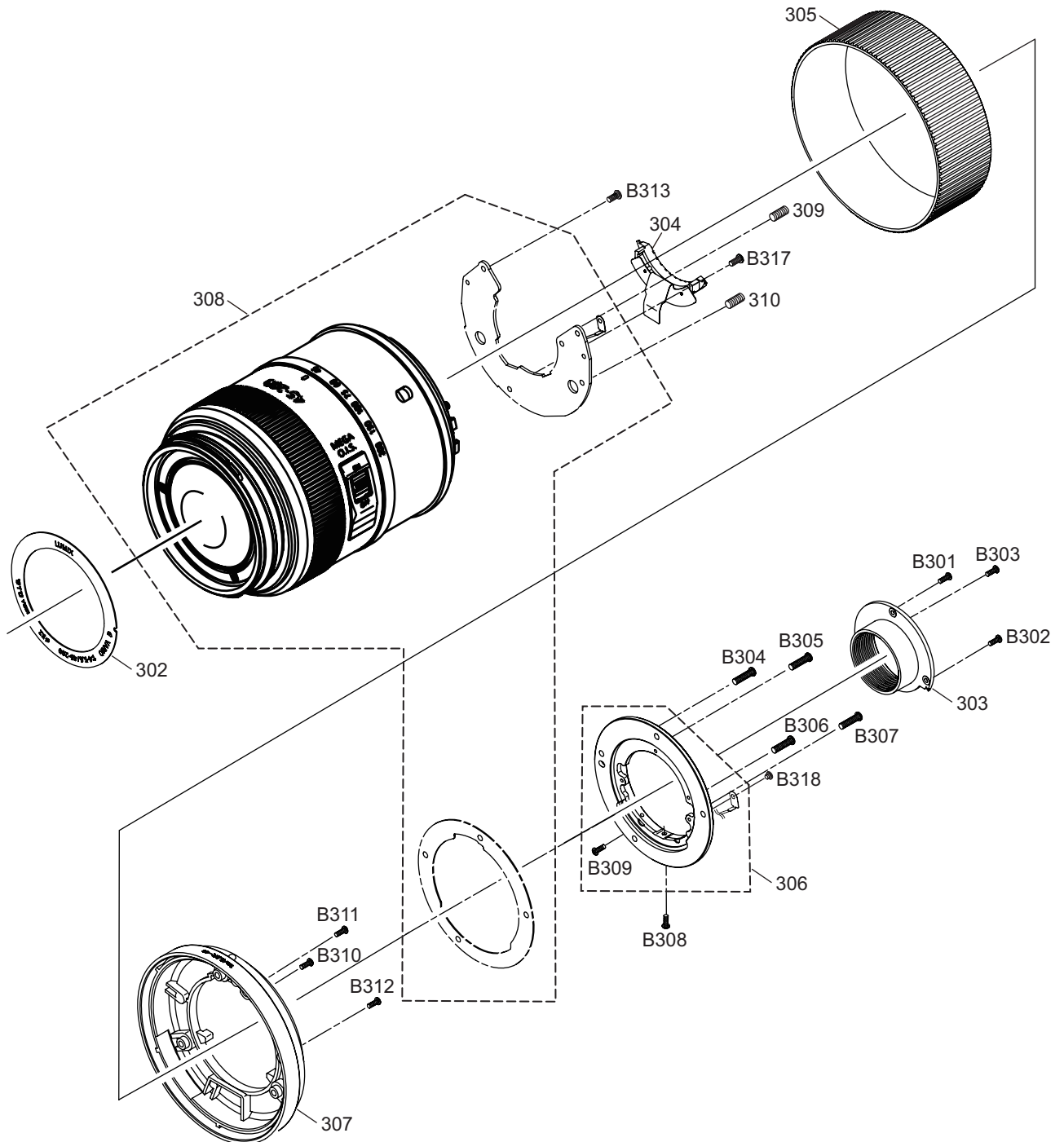

S6.4. Packing Parts and Accessories Section (1)

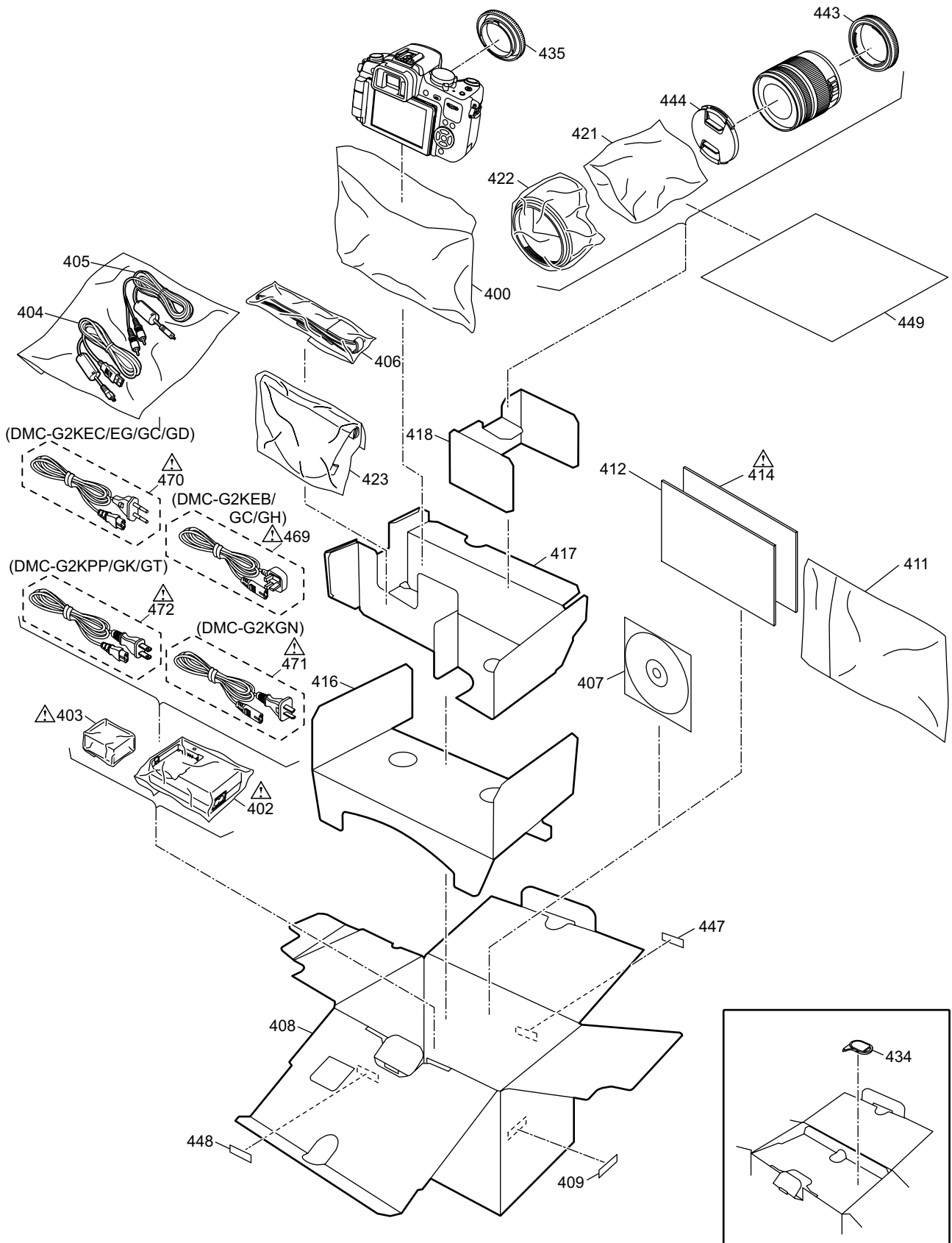

S6.5. Packing Parts and Accessories Section (2)

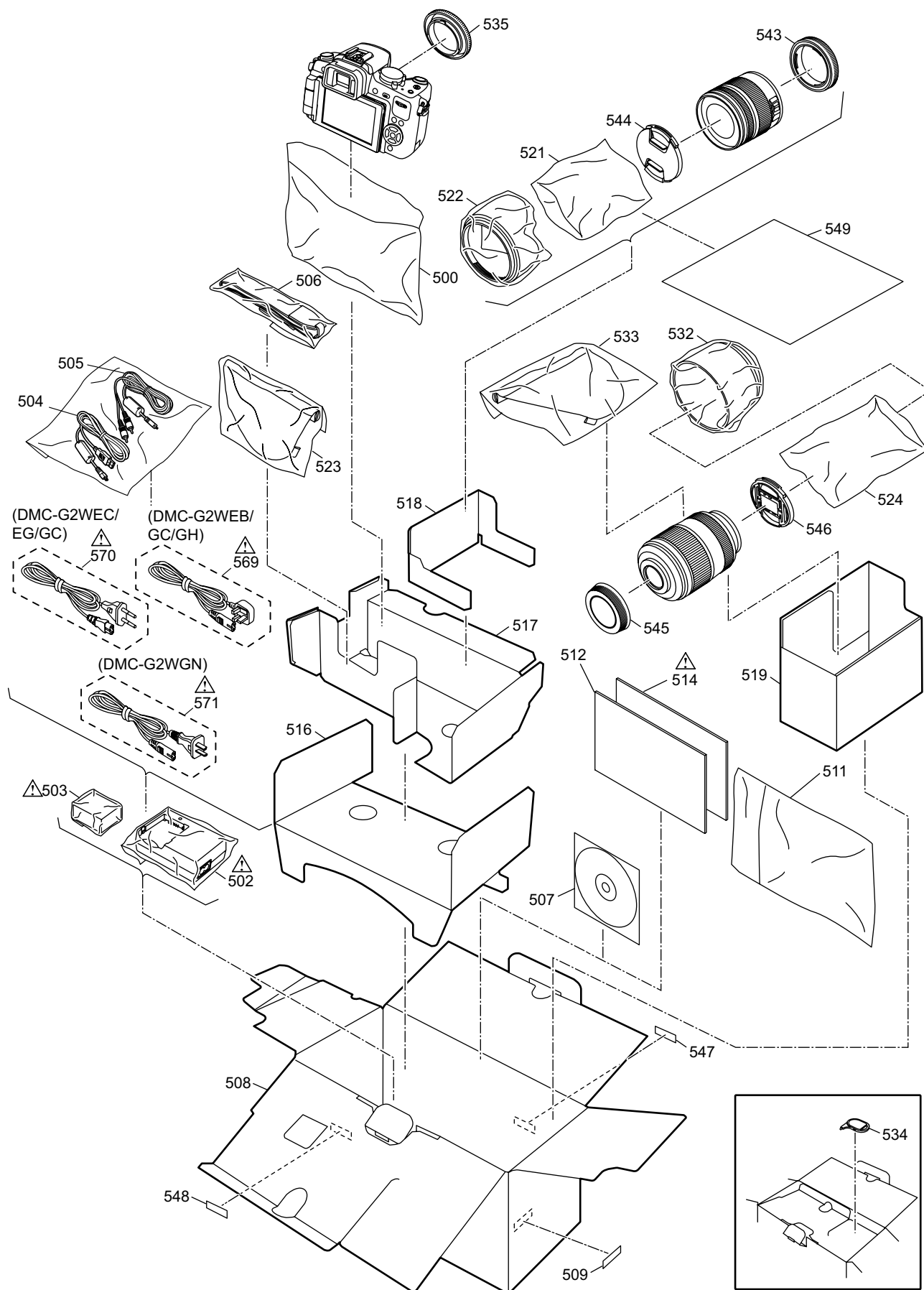

S6.6. Packing Parts and Accessories Section (3)

