

# Service Manual

Digital Camera/Lens Kit

LUMIX



Model No. **DMC-G1KPP**

**DMC-G1KEB**

**DMC-G1KEC**

**DMC-G1KEG**

**DMC-G1KGC**

**DMC-G1KGD**

**DMC-G1KGH**

**DMC-G1K GK**

**DMC-G1KGN**

**DMC-G1KGT**

**DMC-G1KGJ**

Vol. 1

Colour

(K).....Black Type

(A).....Blue Type (except GD/GN/GT/GJ)

(R).....Red Type (except GD/GN/GT/GJ)

## **WARNING**

This service information is designed for experienced repair technicians only and is not designed for use by the general public. It does not contain warnings or cautions to advise non-technical individuals of potential dangers in attempting to service a product. Products powered by electricity should be serviced or repaired only by experienced professional technicians. Any attempt to service or repair the product or products dealt with in this service information by anyone else could result in serious injury or death.

**Panasonic**<sup>®</sup>

© Panasonic Corporation 2008. Unauthorized copying and distribution is a violation of law.

# TABLE OF CONTENTS

	PAGE
<b>1 Safety Precaution</b> .....	<b>3</b>
1.1. General Guidelines .....	3
1.2. Leakage Current Cold Check .....	3
1.3. Leakage Current Hot Check (See Figure 1.) .....	3
1.4. How to Discharge the Capacitor on Flash Sub PCB .....	4
<b>2 Warning</b> .....	<b>5</b>
2.1. Prevention of Electrostatic Discharge (ESD) to Electrostatically Sensitive (ES) Devices .....	5
2.2. How to Recycle the Lithium Ion Battery (U.S. Only) .....	5
2.3. Caution for AC Cord(For EB/GC/GH) .....	6
2.4. How to Replace the Lithium Battery .....	7
<b>3 Service Navigation</b> .....	<b>8</b>
3.1. Introduction .....	8
3.2. Important Notice .....	8
3.3. General Description About Lead Free Solder (PbF) .....	9
3.4. How to Define the Model Suffix (NTSC or PAL model) .....	10
<b>4 Specifications</b> .....	<b>13</b>
<b>5 Location of Controls and Components</b> .....	<b>14</b>
<b>6 Service Mode</b> .....	<b>34</b>
6.1. Error Code Memory Function .....	34
<b>7 Troubleshooting Guide</b> .....	<b>36</b>
<b>8 Service Fixture &amp; Tools</b> .....	<b>39</b>
8.1. Service Fixture and Tools .....	39
8.2. Clean Box .....	40
8.3. Service Position .....	41
<b>9 Disassembly and Assembly Instructions</b> .....	<b>42</b>
9.1. Disassembly Flow Chart .....	42
9.2. PCB Location .....	42
9.3. Disassembly Procedure .....	43
9.4. Disassembly and Assemble Procedure for the Lens .....	51
<b>10 Measurements and Adjustments</b> .....	<b>54</b>
10.1. Matrix Chart for Replaced Part and Necessary Adjustment .....	54
<b>11 Maintenance</b> .....	<b>55</b>

PAGE

# 1 Safety Precautions

## 1.1. General Guidelines

### 1. IMPORTANT SAFETY NOTICE

There are special components used in this equipment which are important for safety. These parts are marked by

 in the Schematic Diagrams, Circuit Board Layout, Exploded Views and Replacement Parts List. It is essential that these critical parts should be replaced with manufacturer's specified parts to prevent X-RADIATION, shock, fire, or other hazards. Do not modify the original design without permission of manufacturer.

2. An Isolation Transformer should always be used during the servicing of AC Adaptor whose chassis is not isolated from the AC power line. Use a transformer of adequate power rating as this protects the technician from accidents resulting in personal injury from electrical shocks. It will also protect AC Adaptor from being damaged by accidental shorting that may occur during servicing.
3. When servicing, observe the original lead dress. If a short circuit is found, replace all parts which have been overheated or damaged by the short circuit.
4. After servicing, see to it that all the protective devices such as insulation barriers, insulation papers shields are properly installed.
5. After servicing, make the following leakage current checks to prevent the customer from being exposed to shock hazards.

## 1.2. Leakage Current Cold Check

1. Unplug the AC cord and connect a jumper between the two prongs on the plug.
2. Measure the resistance value, with an ohmmeter, between the jumpered AC plug and each exposed metallic cabinet part on the equipment such as screwheads, connectors, control shafts, etc. When the exposed metallic part has a return path to the chassis, the reading should be between  $1\text{ M}\Omega$  and  $5.2\text{ M}\Omega$ . When the exposed metal does not have a return path to the chassis, the reading must be infinity.

## 1.3. Leakage Current Hot Check (See Figure 1.)

1. Plug the AC cord directly into the AC outlet. Do not use an isolation transformer for this check.
2. Connect a  $1.5\text{ k}\Omega$ ,  $10\text{ W}$  resistor, in parallel with a  $0.15\text{ }\mu\text{F}$  capacitor, between each exposed metallic part on the set and a good earth ground, as shown in Figure 1.
3. Use an AC voltmeter, with  $1\text{ k}\Omega/\text{V}$  or more sensitivity, to measure the potential across the resistor.
4. Check each exposed metallic part, and measure the voltage at each point.
5. Reverse the AC plug in the AC outlet and repeat each of the above measurements.
6. The potential at any point should not exceed  $0.75\text{ V RMS}$ . A leakage current tester (Simpson Model 229 or equivalent) may be used to make the hot checks, leakage current must not exceed  $1/2\text{ mA}$ . In case a measurement is outside of the limits specified, there is a possibility of a shock hazard, and the equipment should be repaired and rechecked before it is returned to the customer.

Hot-Check Circuit

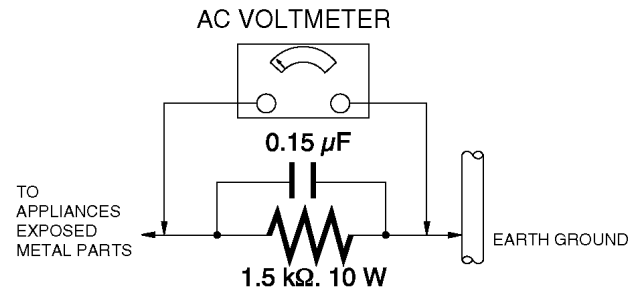

Figure. 1

## 1.4. How to Discharge the Capacitor on Flash Sub PCB

### CAUTION:

1. Be sure to discharge the capacitor on FLASH SUB PCB.
2. Be careful of the high voltage circuit on FLASH SUB PCB when servicing.

### [Discharging Procedure]

1. Refer to the disassemble procedure and Remove the necessary parts/unit.
2. Put the insulation tube onto the lead part of Resistor (ERG5SJ102:1k $\Omega$  /5W).  
(An equivalent type of resistor may be used.)
3. Put the resistor between both terminals of capacitor on FLASH SUB PCB for approx. 5 seconds.
4. After discharging confirm that the capacitor voltage is lower than 10V using a voltmeter.

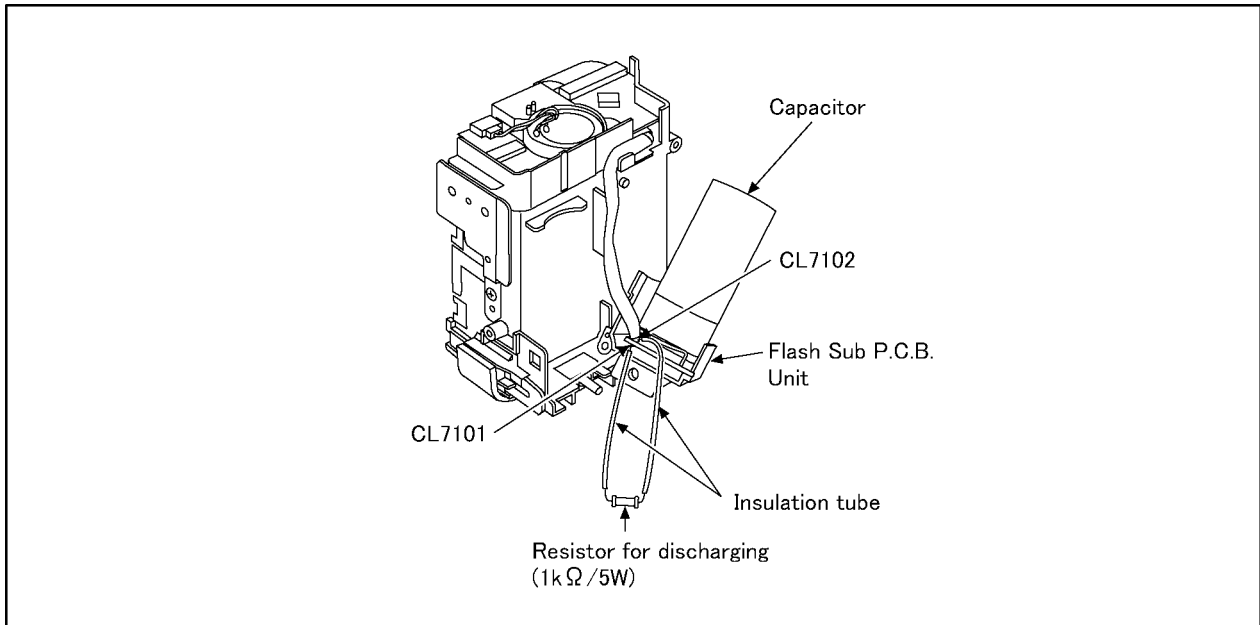

Fig. F1

## 2 Warning

### 2.1. Prevention of Electrostatic Discharge (ESD) to Electrostatically Sensitive (ES) Devices

Some semiconductor (solid state) devices can be damaged easily by static electricity. Such components commonly are called Electrostatically Sensitive (ES) Devices.

Examples of typical ES devices are image sensor, IC (integrated circuits) and some field-effect transistors and semiconductor "chip" components.

The following techniques should be used to help reduce the incidence of component damage caused by electrostatic discharge (ESD).

1. Immediately before handling any semiconductor component or semiconductor-equipped assembly, drain off any ESD on your body by touching a known earth ground. Alternatively, obtain and wear a commercially available discharging ESD wrist strap, which should be removed for potential shock reasons prior to applying power to the unit under test.
2. After removing an electrical assembly equipped with ES devices, place the assembly on a conductive surface such as aluminum foil, to prevent electrostatic charge buildup or exposure of the assembly.
3. Use only a grounded-tip soldering iron to solder or unsolder ES devices.
4. Use only an antistatic solder removal device. Some solder removal devices not classified as "antistatic (ESD protected)" can generate electrical charge sufficient to damage ES devices.
5. Do not use freon-propelled chemicals. These can generate electrical charges sufficient to damage ES devices.
6. Do not remove a replacement ES device from its protective package until immediately before you are ready to install it. (Most replacement ES devices are packaged with leads electrically shorted together by conductive foam, aluminum foil or comparable conductive material).
7. Immediately before removing the protective material from the leads of a replacement ES device, touch the protective material to the chassis or circuit assembly into which the device will be installed.

**CAUTION :**

Be sure no power is applied to the chassis or circuit, and observe all other safety precautions.

8. Minimize bodily motions when handling unpackaged replacement ES devices. (Otherwise harmless motion such as the brushing together of your clothes fabric or the lifting of your foot from a carpeted floor can generate static electricity (ESD) sufficient to damage an ES device).

### 2.2. How to Recycle the Lithium Ion Battery (U.S. Only)

**ENGLISH**



A lithium ion battery that is recyclable powers the product you have purchased. Please call 1-800-8-BATTERY for information on how to recycle this battery.

**FRANÇAIS**



L'appareil que vous vous êtes procuré est alimenté par une batterie au lithium-ion recyclable. Pour des renseignements sur le recyclage de la batterie, veuillez composer le 1-800-8-BATTERY.

## 2.3. Caution for AC Cord (For EB/GC/GH)

### 2.3.1. Information for Your Safety

#### IMPORTANT

Your attention is drawn to the fact that recording of pre-recorded tapes or discs or other published or broadcast material may infringe copyright laws.

#### WARNING

To reduce the risk of fire or shock hazard, do not expose this equipment to rain or moisture.

#### CAUTION

To reduce the risk of fire or shock hazard and annoying interference, use the recommended accessories only.

#### FOR YOUR SAFETY

##### DO NOT REMOVE THE OUTER COVER

To prevent electric shock, do not remove the cover. No user serviceable parts inside. Refer servicing to qualified service personnel.

### 2.3.2. Caution for AC Mains Lead

For your safety, please read the following text carefully.

This appliance is supplied with a moulded three-pin mains plug for your safety and convenience.

A 5-ampere fuse is fitted in this plug.

Should the fuse need to be replaced please ensure that the replacement fuse has a rating of 5 amperes and it is approved by ASTA or BSI to BS1362

Check for the ASTA mark or the BSI mark on the body of the fuse.



If the plug contains a removable fuse cover you must ensure that it is refitted when the fuse is replaced.

If you lose the fuse cover, the plug must not be used until a replacement cover is obtained.

A replacement fuse cover can be purchased from your local Panasonic Dealer.

If the fitted moulded plug is unsuitable for the socket outlet in your home then the fuse should be removed and the plug cut off and disposed of safely.

There is a danger of severe electrical shock if the cut off plug is inserted into any 13-ampere socket.

If a new plug is to be fitted please observe the wiring code as shown below.

If in any doubt, please consult a qualified electrician.

### 2.3.2.1. Important

The wires in this mains lead are coloured in accordance with the following code:

Blue	Neutral
Brown	Live

As the colours of the wires in the mains lead of this appliance may not correspond with the coloured markings identifying the terminals in your plug, proceed as follows:

The wire which is coloured BLUE must be connected to the terminal in the plug which is marked with the letter N or coloured BLACK.

The wire which is coloured BROWN must be connected to the terminal in the plug which is marked with the letter L or coloured RED.

Under no circumstances should either of these wires be connected to the earth terminal of the three pin plug, marked with the letter E or the Earth Symbol.



### 2.3.2.2. Before Use

Remove the Connector Cover as follows.

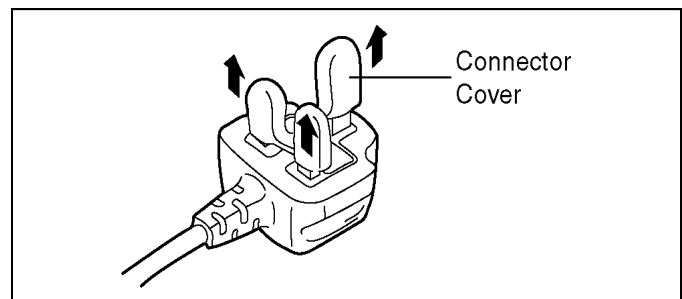

### 2.3.2.3. How to Replace the Fuse

1. Remove the Fuse Cover with a screwdriver.

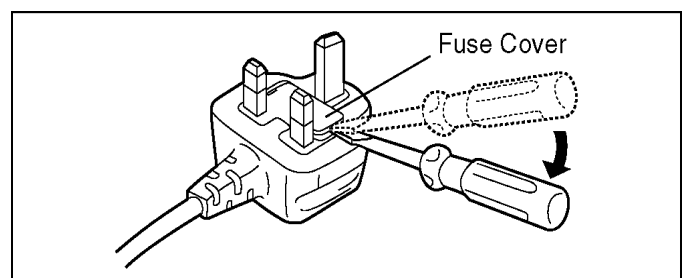

2. Replace the fuse and attach the Fuse cover.

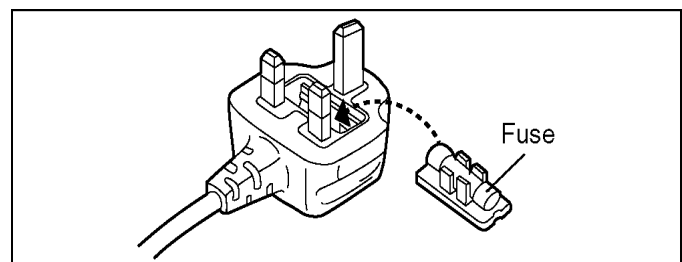

## 2.4. How to Replace the Lithium Battery

### 2.4.1. Replacement Procedure

1. Remove the REMOTE PCB. (Refer to Disassembly Procedures.)
2. Remove the Lithium battery (Ref. No. "B7351" at component side of REMOTE PCB) and then replace it into new one.

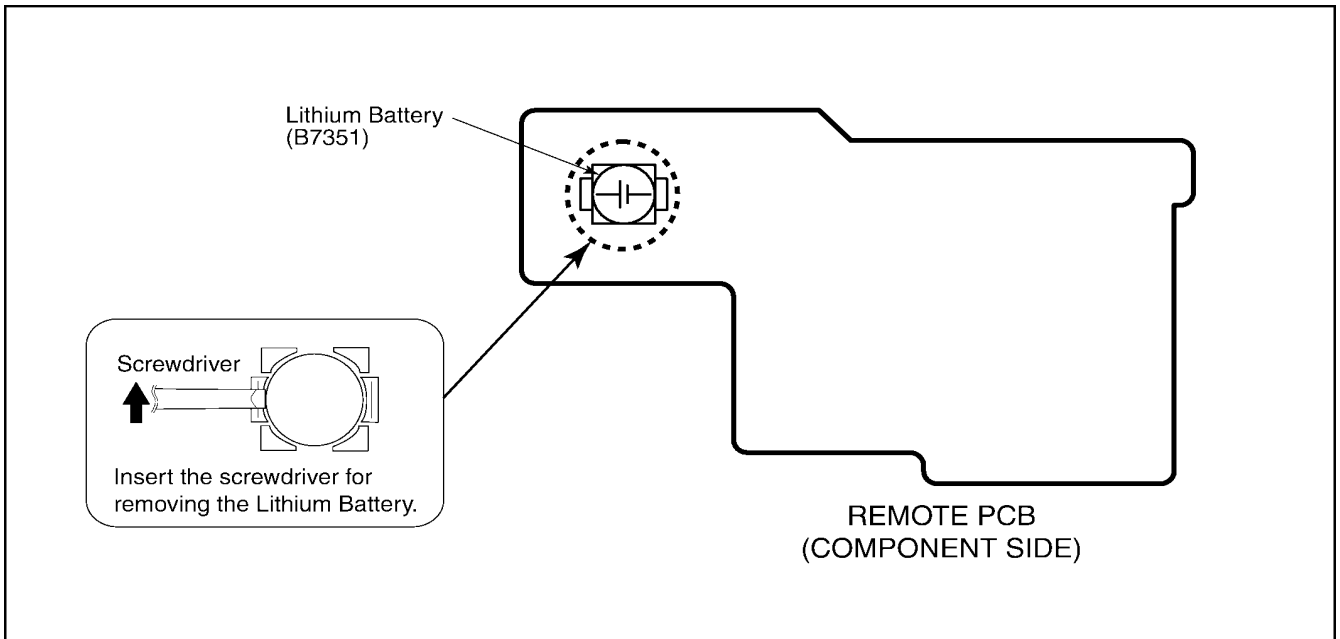

#### NOTE:

This Lithium battery is a critical component.

(Type No.: ML421S/ZT **Manufactured by Energy Company, Panasonic Corporation.**)

It must never be subjected to excessive heat or discharge.

It must therefore only be fitted in requirement designed specifically for its use.

Replacement batteries must be of same type and manufacture.

They must be fitted in the same manner and location as the original battery, with the correct polarity contacts observed.

Do not attempt to re-charge the old battery or re-use it for any other purpose.

It should be disposed of in waste products destined for burial rather than incineration.

#### (For English)

### CAUTION

Danger of explosion if battery is incorrectly replaced.

Replace only with the same or equivalent type recommended by the manufacturer.

Dispose of used batteries according to the manufacturer's instructions.

#### (For German)

### ACHTUNG

Explosionsgefahr bei falschem Anbringen der Batterie. Ersetzen Sie nur mit einem äquivalentem vom Hersteller empfohlenem Typ.

Behandeln Sie gebrauchte Batterien nach den Anweisungen des Herstellers.

#### (For French)

### MISE EN GARDE

Une batterie de remplacement inappropriée peut exploser. Ne remplacez qu'avec une batterie identique ou d'un type recommandé par le fabricant. L'élimination des batteries usées doit être faite conformément aux instructions du fabricant.

#### NOTE:

Above caution is applicable for a battery pack which is for DMC-G1K series, as well.

## 3 Service Navigation

### 3.1. Introduction

This service manual contains technical information, which allow service personnel's to understand and service this model.

Please place orders using the parts list and not the drawing reference numbers.

If the circuit is changed or modified, the information will be followed by service manual to be controlled with original service manual.

### 3.2. Important Notice

#### 3.2.1. Camera Body Unit

##### 3.2.1.1. About Mount Box Block (Ref. 8)

1. This Service Manual does not contain the repair service information for "MOUNT BOX BLOCK"(Ref.8), because it requires special facilities and equipment.
  - a. Schematic diagram, Block diagram and P.C.B. layout of "MOUNT BOX BLOCK".
  - b. Parts list for individual parts of "MOUNT BOX BLOCK"
2. If the "MOUNT BOX BLOCK" is confirmed as defective, exchange the "MOUNT BOX BLOCK" as supplied as service parts.
3. Before exchange the "MOUNT BOX BLOCK", the performances must be carefully checked ,by following the "7.Troubleshooting Guide" section of this service manual.

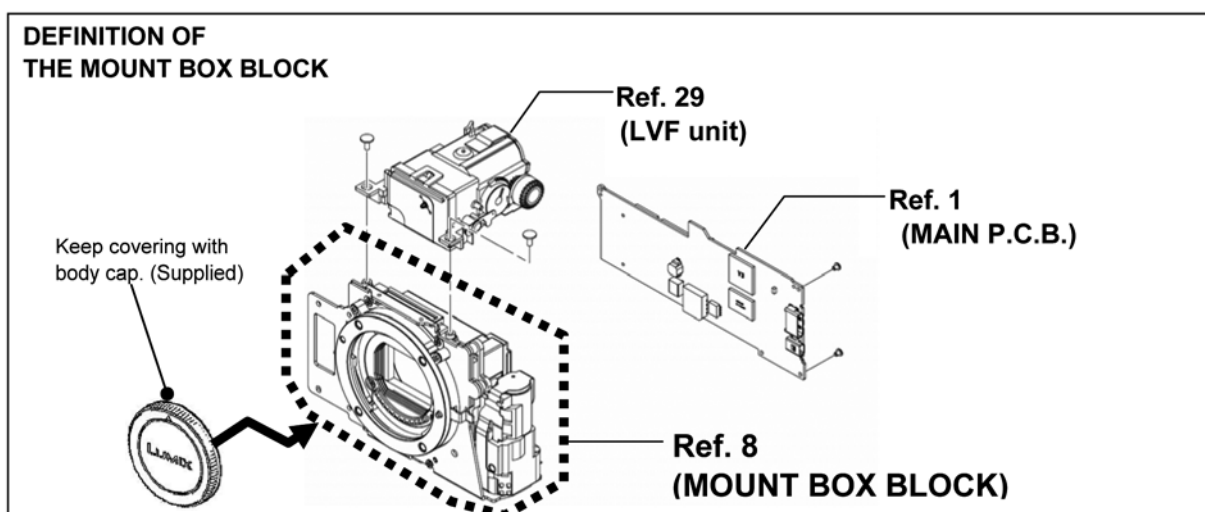

Fig. S1

#### Important:

1. After replacing the MOUNT BOX BLOCK, the mount box data has to be stored to the unit.  
For more details, consult the adjustment instruction which is available together with the Maintenance software at "software download" on the "Support Information from NWBG/VDBG-AVC" web-site in "TSN system".
2. The full adjustment procedures must be performed after replacing the "MOUNT BOX BLOCK", otherwise picture quality can not be meet with specification.

##### 3.2.1.2. About Main PCB (Ref. 1)

1. This Service Manual does not contain the repair service information for "MAIN P.C.B."(Ref.1), because it requires special facilities and equipment.
  - a. Schematic diagram, Block diagram and P.C.B. layout of "MAIN P.C.B.".
  - b. Parts list for individual parts of "MAIN P.C.B."
2. When a part replacement is required for repairing "MAIN P.C.B.", replace as an assembled parts. (MAIN P.C.B.)
3. The following category is recycle module part. please send it/them to Central Repair Center.  
\*MAIN P.C.B. (VEP56071A)
4. Before exchange the "MAIN P.C.B.", the performances must be carefully checked ,by following the "7.Troubleshooting Guide" section of this service manual.

#### Important:

1. Before replacing the "MAIN P.C.B.", proceed the EEPROM data backup from the unit. After replacing the MAIN PCB, overwrite the EEPROM data with backup data from the unit. before proceeding the adjustment /inspection.  
For more details, consult the adjustment instruction which is available together with the Maintenance software at "software download" on the "Support Information from NWBG/VDBG-AVC" web-site in "TSN system".
2. The full adjustment procedures must be performed After replacing the "MAIN P.C.B.", otherwise Picture quality can not be meet with specification.



### 3.2.2. Lens Unit

1. This Service Manual does not contain the repair service information for "LENS MAIN BLOCK UNIT"(Ref.208), because it requires special facilities and equipment.
2. "LENS MAIN BLOCK UNIT" performance must be confirmed with the "7.Troubleshooting Guide" section of this service manual.
3. In case of the "LENS MAIN BLOCK UNIT" defect, contact to the service department of sales company.

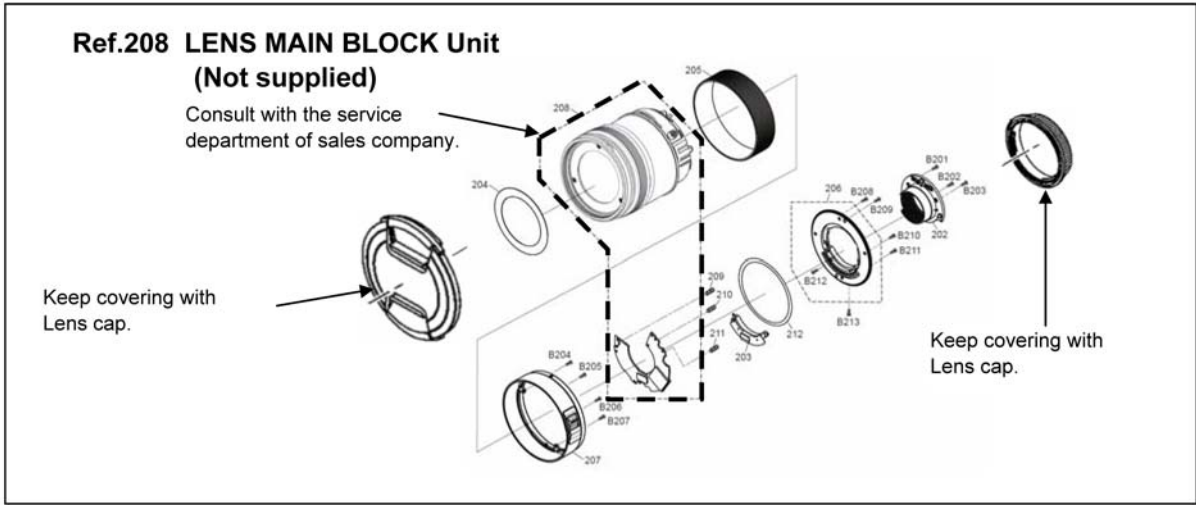

Fig. S2

### 3.3. General Description About Lead Free Solder (PbF)

The lead free solder has been used in the mounting process of all electrical components on the printed circuit boards used for this equipment in considering the globally environmental conservation.

The normal solder is the alloy of tin (Sn) and lead (Pb). On the other hand, the lead free solder is the alloy mainly consists of tin (Sn), silver (Ag) and Copper (Cu), and the melting point of the lead free solder is higher approx.30°C (86°F) more than that of the normal solder.

#### Distinction of PCB Lead Free Solder being used

The letter of "PbF" is printed either foil side or components side on the PCB using the lead free solder.(See right figure)	<b>PbF</b>
---	------------

#### Service caution for repair work using Lead Free Solder (PbF)

- The lead free solder has to be used when repairing the equipment for which the lead free solder is used.  
(Definition: The letter of "PbF" is printed on the PCB using the lead free solder.)
- To put lead free solder, it should be well molten and mixed with the original lead free solder.
- Remove the remaining lead free solder on the PCB cleanly for soldering of the new IC.
- Since the melting point of the lead free solder is higher than that of the normal lead solder, it takes the longer time to melt the lead free solder.
- Use the soldering iron (more than 70W) equipped with the temperature control after setting the temperature at 350±30°C (662±86°F).

#### Recommended Lead Free Solder (Service Parts Route.)

- The following 3 types of lead free solder are available through the service parts route.  
RFKZ03D01K-----(0.3mm 100g Reel)  
RFKZ06D01K-----(0.6mm 100g Reel)  
RFKZ10D01K----- (1.0mm 100g Reel)

#### Note

\* Ingredient: tin (Sn) 96.5%, silver (Ag) 3.0%, Copper (Cu) 0.5%, Cobalt (Co) / Germanium (Ge) 0.1 to 0.3%

### 3.4. How to Define the Model Suffix (NTSC or PAL model)







There are seven kinds of DMC-G1K, regardless of the colours.

- a) DMC-G1K (Japan domestic model)
- b) DMC-G1KPP
- c) DMC-G1KEB/EC/EG/GH
- d) DMC-G1KGC/GJ/GN
- e) DMC-G1KGD
- f) DMC-G1KGT
- g) DMC-G1K GK

What is the difference is that the "INITIAL SETTINGS" data which is stored in Flash ROM mounted on MAIN PCB.

#### 3.4.1. Defining methods:

To define the model suffix to be serviced, refer to the nameplate which is putted on the bottom side of the Unit.

<p><b>a) DMC-G1K (Japan domestic model)</b> The nameplate for this model show the following Safety registration mark.</p> 
<p><b>b) DMC-G1KPP</b> The nameplate for this model show the following Safety registration mark.</p> 
<p><b>c) DMC-G1KEB/EC/EG/GH</b> The nameplate for these models show the following Safety registration mark.</p> 
<p><b>d) DMC-G1KGC/GJ/GN</b> The nameplate for these models show the following Safety registration mark.</p> 
<p><b>e) DMC-G1KGD</b> The nameplate for this model show the following Safety registration mark.</p> 
<p><b>f) DMC-G1KGT</b> The nameplate for this model show the following Safety registration mark.</p> 
<p><b>g) DMC-G1K GK</b> The nameplate for this model show the following Safety registration mark.</p> 

### 3.4.2. INITIAL SETTINGS:

When you replace the MAIN PCB, be sure to perform the initial settings after achieving the adjustment by ordering the following procedure in accordance with model suffix of the unit.

#### 1. IMPORTANT NOTICE:

Before proceeding Initial settings, be sure to read the following CAUTIONS.

**CAUTION 1 : (INITIAL SETTINGS)**

---AFTER REPLACING THE MAIN P.C.B.---

- \*.The model suffix can be chosen **JUST ONE TIME.**  
(Model suffix : "EB/EC/EG/GC/GH/GJ/GK/GN/GT/GD/PP and NONE(JAPAN)")
- \*.Once one of the model suffix have been chosen, the model suffix lists will not be displayed, thus, it can not be changed.

[NOTE: Only for "EG/EB/EC" models]

- \*When one of the "EG, EB, and EC" are chosen, "EG, EB, and EC" are displayed from second times.

#### 2. PROCEDURES:

##### • Preparation

Insert the SD memory card which has a few photo data.

##### • Step 1. The temporary cancellation of initial setting:

Set the Drive mode lever to [ SINGLE ].

While keep pressing [ DISPLAY ] and [ FILM MODE ] buttons simultaneously, turn the Power on.

##### • Step 2. The cancellation of initial setting:

Press the [PLAYBACK] button, then playback the picture.

Press [ FILM MODE ] and "[ UP ] of Cursor buttons" simultaneously, then turn the Power off.

##### • Step 3. Turn the Power on:

Set the mode dial to [ P ], and then turn the Power on.

##### • Step 4. Display the INITIAL SETTING:

While keep pressing [ MENU/SET ] and "[ RIGHT ] of Cursor buttons" simultaneously, turn the Power off.

When MAIN P.C.B. is replaced, all of the model suffix is displayed as follows.

There are two kinds of "INITIAL SETTINGS" menu format.

[1. After replacing MAIN P.C.B.]

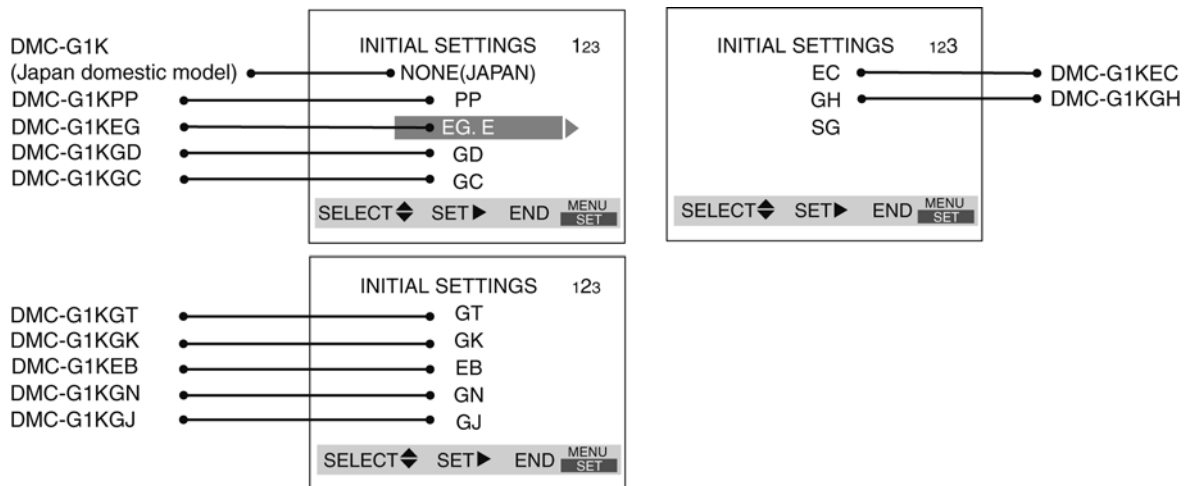

[2. Other than “After replacing MAIN P.C.B.”]

<Other than “EB/EC/EG” models>



<Only “EB/EC/EG” models>

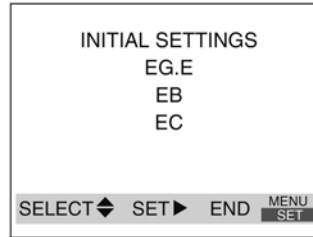

• **Step 5. Set the INITIAL SETTING: (Refer to “CAUTION 1”)**

**[Caution: After replacing MAIN P.C.B.]**

The model suffix can be chosen, **JUST ONE TIME.**

Once one of the model suffix have been chosen, the model suffix lists will not be displayed, thus, it can be changed.

Select the area carefully.

Select the area with pressing “[ UP ] / [ DOWN ] of Cursor buttons”, and then press the “[ RIGHT ] of Cursor buttons”.

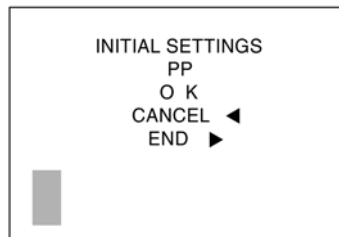

The only set area is displayed, and then press the “[ RIGHT ] of Cursor buttons” after confirmation.  
(The unit is powered off automatically.)

Confirm the display of “PLEASE SET THE CLOCK” in English when the unit is turned on again.

• **Step 6. CONFIRMATION:**

The display shows “PLEASE SET THE CLOCK” when turn the Power on again.

When the unit is connected to PC with USB cable, it is detected as removable media.

1) As for your reference Default setting condition is given in the following table.

• **Default setting (After “INITIAL SETTINGS”)**

	MODEL	VIDEO OUTPUT	LANGUAGE	DATE	REMARKS
a)	DMC-G1K (Japan domestic model)	NTSC	Japanese	Year/Month/Date	
b)	DMC-G1KPP	NTSC	English	Month/Date/Year	
c)	DMC-G1KEB/EC/EG/GC/GH/GN	PAL	English	Date/Month/Year	
d)	DMC-G1KGK	PAL	Chinese (simplified)	Year/Month/Date	
e)	DMC-G1KGT	NTSC	Chinese (traditional)	Year/Month/Date	
f)	DMC-G1KGD	NTSC	Korean	Year/Month/Date	
g)	DMC-G1KGJ	PAL	Thai	Date/Month/Year	

# 4 Specifications

**Digital Camera Body (DMC-G1):** Information for your safety

<b>Power Source:</b>	DC 9.3 V
<b>Power Consumption:</b>	2.8 W (When recording with LCD Monitor) 2.6 W (When recording with Viewfinder) 1.7 W (When playing back with LCD Monitor) 1.6 W (When playing back with Viewfinder)

**Camera effective pixels:** 12,100,000 pixels  
**Image sensor:** 4/3" Live MOS sensor, total pixel number 13,060,000 pixels, Primary color filter  
**Digital zoom:** Max. 4×  
**Extended optical zoom:** ON/OFF simple enlargement (compatible with lenses from other manufacturers)  
**Focus:** Auto focus/Manual focus, Face detection/AF Tracking/23-area-focusing/1-area-focusing  
**Shutter system:** Focal-plane shutter  
**Burst recording:**  
**Burst speed:** 3 pictures/second (High speed), 2 pictures/second (Low speed)  
**Number of recordable pictures:** Max. 7 pictures (when there are RAW files) Depends on the capacity of the card (when there are no RAW files)  
**ISO sensitivity:** AUTO/ $\frac{1}{50}$ /100/200/400/800/1600/3200  
**Shutter speed:** B (Bulb) (max. 4 minutes), 60 seconds to 1/4000th of a second  
**Metering range:** EV 0 to EV 18  
**White balance:** Auto white balance/Daylight/Cloudy/Shade/Incandescent lights/Flash/White set1/White set2/White balance K set  
**Exposure (AE):** Program AE (P)/Aperture-priority AE (A)/Shutter-priority AE (S)/Manual exposure (M)/AUTO Exposure compensation (1/3 EV Step, -3 EV to +3 EV)  
**Metering mode:** Multiple/Center weighted/Spot  
**LCD monitor:** 3.0" TFT LCD (Approx. 460,000 dots) (field of view ratio about 100%)  
**Viewfinder:** Color LCD Viewfinder (Approx. 1,440,000 dots) (field of view ratio about 100%) (with diopter adjustment -4 to +4 diopter)  
**Flash:** Built-in pop up flash GN 11.0 (equivalent) Flash range: Approx. 45 cm (1.48 feet) to 6.2 m (20.3 feet) (When the 14-45 mm/F3.5-5.6 lens included in DMC-G1K is mounted, at the wide end, and [ISO AUTO] is set) AUTO, AUTO/Red-eye reduction, Forced ON, Forced ON/Red-eye reduction, Slow sync., Slow sync./Red-eye reduction, Forced OFF  
**Flash synchronization speed:** Equal to or smaller than 1/160th of a second  
**Recording media:** SD Memory Card/SDHC Memory Card/MultiMediaCard  
**Picture size**  
**Still picture:** When the aspect ratio setting is [4:3] 4000×3000 pixels, 2816×2112 pixels, 2048×1536 pixels  
 When the aspect ratio setting is [3:2] 4000×2672 pixels, 2816×1880 pixels, 2048×1360 pixels  
 When the aspect ratio setting is [16:9] 4000×2248 pixels, 2816×1584 pixels, 1920×1080 pixels

**Quality:** RAW/RAW+Fine/RAW+Standard/Fine/Standard  
**Recording file format:** JPEG (based on "Design rule for Camera File system", based on "Exif 2.21" standard)/DPOF corresponding  
**Interface**  
**Digital:** "USB 2.0" (High Speed)  
**Analog video:** NTSC  
**Terminal**  
**[REMOTE]:**  $\phi$  2.5 mm jack  
**[DIGITAL/V.OUT]:** Dedicated jack (8 pin)  
**[HDMI]:** MiniHDMI TypeC (1.3b corresponding)  
**[DC IN]:** None (when using an AC adaptor, use optional DC cable)  
**Dimensions:** Approx. 124 mm (W)×83.6 mm (H)×45.2 mm (D) [4 7/8" (W)×3 5/16" (H)×1 13/16" (D)] (excluding the projecting parts)  
**Mass (weight):** Approx. 385 g/13.6 oz (camera body), Approx. 635 g/22.4 oz (with the 14-45 mm/F3.5-5.6 lens included in DMC-G1K, card and battery)  
**Operating temperature:** 0 °C to 40 °C (32 °F to 104 °F)  
**Operating humidity:** 10% to 80%

**AC Adaptor (Panasonic DE-A49B):** Information for your safety

<b>Input:</b>	110 V to 240 V ~ 50/60 Hz, 0.3 A
<b>Output:</b>	DIGITAL CAMERA 9.3 V = 1.2 A CHARGE 8.4 V = 0.65 A

**Battery Pack (lithium-ion) (Panasonic DMW-BLB13PP):** Information for your safety

<b>Voltage:</b>	7.2 V
-----------------	-------

**Interchangeable Lens (H-FS014045)**  
**"LUMIX G VARIO 14-45 mm/F3.5-5.6 ASPH./MEGA O.I.S."**  
**Focal length:** f=14 mm to 45 mm (35 mm film camera equivalent: 28 mm to 90 mm)  
**Aperture type:** 7 leaf shutters/iris diaphragm/circular diaphragm  
**Aperture range:** F3.5 (Wide) to F5.6 (Tele)  
**Minimum aperture value:** F22  
**Lens construction:** 12 elements in 9 groups (1 aspherical lens)  
**In focus distance:** 0.3 m (0.99 feet) to  $\infty$  (from the focus distance reference line)  
**Maximum image magnification:** 0.17× (35 mm film camera equivalent: 0.34×)  
**Optical image stabilizer:** Available  
**Mount:** "Micro Four Thirds Mount"  
**Angle of view:** 75° (Wide) to 27° (Tele)  
**Filter diameter:** 52 mm (2.05 inch)  
**Max. diameter:** 60 mm (2.36 inch)  
**Overall length:** Approx. 60 mm (2.36 inch) (from the tip of the lens to the base side of the lens mount)  
**Mass (weight):** Approx. 195 g (6.88 oz)

# 5 Location of Controls and Components

## Names of the Components

### ■ Camera body

- 1 Flash
- 2 Sensor
- 3 Self-timer indicator  
AF assist lamp
- 4 Lens release button
- 5 Lens lock pin
- 6 Mount
- 7 Lens fitting mark
- 8 Front dial

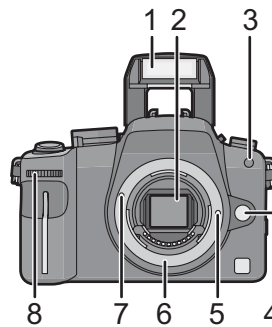

- 9 [LVF/LCD] button
- 10 Diopter adjustment dial
- 11 Viewfinder
- 12 Eye sensor
- 13 Playback button
- 14 [AF/AE LOCK] button
- 15 Camera ON/OFF switch
- 16 LCD monitor
- 17 [DISPLAY] button
- 18 Delete button/  
Preview button
- 19 [MENU/SET] button
- 20 Cursor buttons

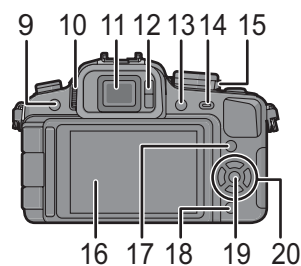

- ▲/ISO
- ◀/AF mode
- ▼/Function button

Assign Menu to ▼ button. It is convenient to register Menu that is used often.  
 [ASPECT RATIO]/[QUALITY]/[METERING MODE]/[I.EXPOSURE]/[GUIDE LINE]  
 ▶/WB (White balance)

- 21 Focus mode dial
- 22 Flash open lever
- 23 Drive mode lever
- Single:
- Burst:
- Auto bracket:
- Self-timer:
- 24 Shutter button
- 25 Focus distance reference mark
- 26 Hot shoe
- 27 Mode dial
- 28 Status indicator
- 29 [Q.MENU] button
- 30 [FILM MODE] button

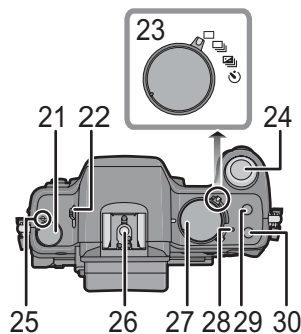

- 31 [REMOTE] socket
- 32 Strap eyelet
  - Be sure to attach the strap when using the camera to ensure that you will not drop it.
- 33 [HDMI] socket
- 34 [DIGITAL/V.OUT] socket

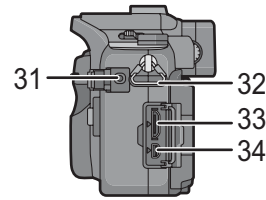

- 35 Card door
- 36 DC cable cover

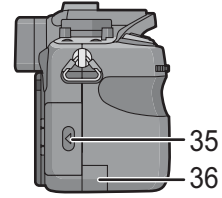

- 37 Battery door
- 38 Release lever
- 39 Tripod receptacle
  - When you use a tripod, make sure the tripod is stable when the camera is attached to it.

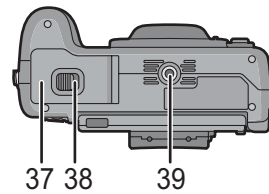

■ Lens

**H-FS014045 (LUMIX G VARIO 14–45 mm/F3.5–5.6 ASPH./MEGA O.I.S.)**

- 40 Tele
- 41 Lens surface
- 42 Focus ring
- 43 Wide
- 44 Zoom ring
- 45 [O.I.S.] switch
- 46 Contact point
- 47 Lens fitting mark

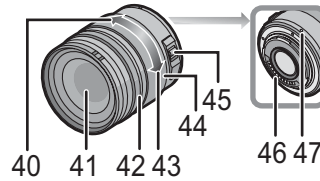

■ Battery charger/AC adaptor

- 48 Power input socket [AC IN]
- 49 [CHARGE] indicator
- 50 Power output socket [DC OUT]
- 51 Battery holder

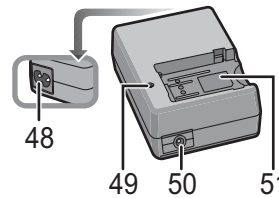

## Selecting the [REC] Mode

When the [REC] mode is selected, the camera can be set to the Intelligent auto mode in which the optimal settings are established in line with the subject to be recorded and the recording conditions, or to the scene mode which enables you to take pictures that match the scene being recorded.

### 1 Turn the camera on.

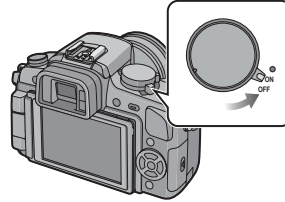

### 2 Switching the mode by rotating the mode dial.

Align a desired mode with part (A).

- Rotate the mode dial slowly and surely to adjust to each mode. (The mode dial rotates 360°)



#### Basic

##### **iA** Intelligent auto mode

The subjects are recorded using settings automatically selected by the camera.

##### **P** Program AE mode

The subjects are recorded using your own settings.

#### Advanced

##### **A** Aperture-priority AE mode

The shutter speed is automatically determined by the aperture value you set.

##### **S** Shutter-priority AE mode

The aperture value is automatically determined by the shutter speed you set.

##### **M** Manual exposure mode

The exposure is adjusted by the aperture value and the shutter speed which are manually adjusted.

##### **CUST** Custom mode

Use this mode to take pictures with previously registered settings.

##### **My color mode**

Easily check the color of light, brightness, and vividness of color when the picture is taken.

##### **SCN** Scene mode

This allows you to take pictures that match the scene being recorded.

#### Advanced scene mode

##### **Portrait mode**

Use this mode to take pictures of people.

##### **Scenery mode**

Use this mode to take pictures of scenery.

##### **Sports mode**

Use this mode to take pictures of sporting events, etc.

##### **Close-up mode**

Use this mode to take picture of close-by subject.

##### **Night portrait mode**

Use this mode to take pictures of night scenes and people with night time scenery.



## About the Lens

This unit can use the dedicated lenses compatible to the Micro Four Thirds System lens mount specification (Micro Four Thirds mount) such as the lenses included in DMC-G1K. Select a lens that matches the scene being recorded and your use of the pictures. If you use a lens other than a dedicated interchangeable lens, auto focus cannot be activated and accurate metering is not possible. Also, some functions will not work.

### ■ “Micro Four Thirds Mount”

This is the lens mount standard for the “Micro Four Thirds System”. This was newly developed as interchangeable lens dedicated for digital cameras.



### ■ When using lenses other than the lenses included in DMC-G1K

- Depending on the type of lens, you may not be able to use some functions such as the direction detection function, [STABILIZER], Quick AF and Continuous AF.
- The available flash range etc. differs depending on the aperture value of the lens you are using.
- Take some test pictures with the lens you are using.
- Lens with the Four Thirds™ mount specification can be used by using the mount adaptor (DMW-MA1; optional). However, [AFC] mode and continuous AF function cannot be used. Only manual focus is possible when using a lens that is not compatible with the Contrast AF. There are some restrictions to some other functions too.



Because of its structure, Micro Four Thirds mount specification lenses cannot be used on the Four Thirds mount specification cameras. It can only be used on the Micro Four Thirds mount specification cameras.

### Lens Installation Combination Diagram

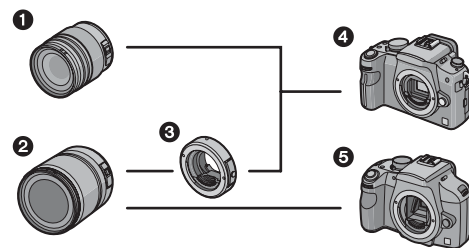

- 1 Micro Four Thirds mount specification lens\*
- 2 Four Thirds mount specification lens
- 3 Mount adaptor (DMW-MA1)
- 4 Micro Four Thirds mount specification camera (DMC-G1)
- 5 Four Thirds mount specification camera

\* It cannot be mounted on the Four Thirds mount specification camera.

Refer to catalogues/Web pages for most current information regarding compatible lenses.  
<http://panasonic.co.jp/pavc/global/cs> (This Site is English only.)

## Cautions for Use

In the event of abnormal operation (e.g. if the unit emits smoke or an unusual smell), immediately stop operating the unit and consult the Panasonic Customer Care Centre on 132600.

### Optimal use of the camera

**Take care not to drop or knock the unit or put a lot of pressure on it.**

- Take care not to knock or drop the bag/case that you inserted the camera in as the shock may cause damage to the camera, lens or LCD monitor.
- Do not use a paper bag as it can easily rip causing the camera to fall and be damaged.
- We strongly recommend you purchase a good camera bag/case from your local dealer to protect your camera.

**Keep the camera as far away as possible from electromagnetic equipment (such as microwave ovens, TVs, video games etc.).**

- If you use the camera on top of or near a TV, the pictures on the camera may be disrupted by electromagnetic wave radiation.
- Do not use the camera near cell phones because doing so may result in noise adversely affecting the pictures.
- Recorded data may be damaged, or pictures may be distorted, by strong magnetic fields created by speakers or large motors.
- Electromagnetic wave radiation generated by microprocessors may adversely affect the camera, disturbing the pictures.
- If the camera is adversely affected by electromagnetic equipment and stops functioning properly, turn the camera off and remove the battery or disconnect AC adaptor. Then reinsert the battery or reconnect AC adaptor and turn the camera on.

**Do not use the camera near radio transmitters or high-voltage lines.**

- If you record near radio transmitters or high-voltage lines, the recorded pictures may be adversely affected.

**Always use the supplied cords and cables. If you use optional accessories, use the cords and the cables supplied with them.**

**Do not extend the cords or the cables.**

**Do not spray the camera with insecticides or volatile chemicals.**

- If the camera is sprayed with such chemicals, the body of the camera may be damaged and the surface finish may peel off.
- Do not keep rubber or plastic products in contact with the camera for a long period of time.

## Cleaning

**Before cleaning the camera, remove the battery or disconnect the power plug from the outlet. Then wipe the camera with a dry soft cloth.**

- When the camera is soiled badly, it can be cleaned by wiping the dirt off with a wrung wet cloth, and then with a dry cloth.
- Wipe off any dust or dirt on the zoom ring and the focus ring with a dry, dust cloth.
- Do not use solvents such as benzine, thinner, alcohol, kitchen detergents, etc., to clean the camera, since it may deteriorate the external case or the coating may peel off.
- When using a chemical cloth, be sure to follow the accompanying instructions.

### ■ About dirt on the image sensor

This camera features an interchangeable lens system so dirt may get inside the camera body when changing lenses. Depending on the recording conditions, dirt on the image sensor may appear on the recorded picture.

Do not change lenses where there is a lot of dust, and always attach the body cap when a lens is not attached to the camera, so that dirt or dust does not get inside the camera body. Remove any dirt on the body cap before attaching it.

### Dust reduction function

This unit has a dust reduction function that will blow off the debris and dust that has affixed to the front of the imaging device. This function will function automatically when the camera is turned on, but if you see dust, perform the [PIXEL REFRESH] in the [CUSTOM MENU] menu.

### Removing dirt on the image sensor

The image sensor is very precise and delicate, so be sure to observe the following when you do have to clean it yourself.

- Blow off the dust on the surface of the image sensor with a commercially available blower brush. Be careful not to blow too strongly.
- Do not put the blower brush further inside than the lens mount.
- Do not let the blower brush touch the image sensor as the image sensor may get scratched.
- Do not use any objects except a blower brush to clean the image sensor.
- If you cannot remove the dirt or dust with the blower, consult the dealer or your nearest Service Centre.

## About the LCD monitor/Viewfinder

- Do not press the LCD monitor with excessive force. Uneven colours may appear on the LCD monitor and it may malfunction.
- If the camera is cold when you turn it on, the picture on the LCD monitor/Viewfinder will be slightly darker than usual at first. However, the picture will return to normal brightness when the internal temperature of the camera increases.

Extremely high precision technology is employed to produce the LCD monitor/Viewfinder screen. However there may be some dark or bright spots (red, blue or green) on the screen. This is not a malfunction. The LCD monitor/Viewfinder screen has more than 99.99% effective pixels with a mere 0.01% of the pixels inactive or always lit. The spots will not be recorded on pictures on a card.

### About the Lens

- Do not press the lens with excessive force.
- Do not leave the camera with the lens facing the sun as rays of light from the sun may cause it to malfunction. Also, be careful when placing the camera outside or near a window.
- When there is dirt (water, oil, and fingerprints, etc.) on the surface of the lens, the picture may be affected. Lightly wipe the surface of the lens with a soft, dry cloth before and after taking pictures.
- Do not place the lens mount facing downwards. Do not allow the lens mount contacts ① to become dirty.

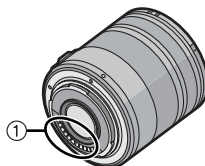

### Battery

**The battery is a rechargeable lithium ion battery. Its ability to generate power comes from the chemical reaction that takes place inside it. This reaction is susceptible to the surrounding temperature and humidity. If the temperature is too high or too low, the operating time of the battery will become shorter.**

**Always remove the battery after use.**

**If you drop the battery accidentally, check to see if the body of the battery and the terminals are damaged.**

- Inserting a damaged battery in the camera will damage the camera.

**Bring charged spare batteries when going out.**

- Be aware that the operating time of the battery becomes shorter in low temperature conditions such as at a ski resort.
- When you travel, do not forget to bring the battery charger (supplied) so that you can charge the battery in the country that you are travelling in.

**Dispose of unusable battery.**

- The battery has a limited life.
- Do not throw the battery into fire because it may cause an explosion.

**Do not allow battery terminals to come into contact with metal objects (such as necklaces, hairpins etc.).**

- This can cause short circuiting or heat generation and you may be badly burned if you touch a battery.

### Charger

- If you use the battery charger near a radio, the radio reception may be disturbed.
- Keep the charger 1 m or more away from radio.
- The charger may generate whirring sounds when it is being used. This is not a malfunction.
- After use, be sure to disconnect the power supply device from the electrical outlet. (A very small amount of current is consumed if it is left connected.)
- Keep the terminals of the charger and battery clean.

### Card

**Do not leave the card where the temperature is high, where electromagnetic waves or static electricity are easily generated or exposed to direct sunlight.**

**Do not bend or drop the card.**

- The card may be damaged or the recorded content may be damaged or deleted.
- Put the card in the card case or the storage bag after use and when storing or carrying the card.
- Do not allow dirt, dust or water to get into the terminals on the back of the card and do not touch the terminals with your fingers.

### When not using the camera for a long period of time

- Store the battery in a cool and dry place with a relatively stable temperature: [Recommended temperature: 15 °C to 25 °C, Recommended humidity: 40% to 60%]
- Always remove the battery and the card from the camera.
- If the battery is left inserted in the camera, it will discharge even if the camera is turned off. If the battery continues to be left in the camera, it will discharge excessively and may become unusable even if charged.
- When storing the battery for a long period of time, we recommend charging it once a year. Remove the battery from the camera and store it again after it has completely discharged.
- We recommend storing the camera with a desiccant (silica gel) when you keep it in a closet or a cabinet.
- **Check all the parts before taking pictures when you have not used the camera for a long period of time.**

### About the picture data

- Recorded data may be damaged or lost if the camera breaks down due to inappropriate handling. Panasonic will not be liable for any damage suffered due to loss of recorded data.

### About tripods

- When you use a tripod, make sure the tripod is stable when this unit is attached to it.
- You may not be able to remove the battery when using a tripod.
- Make sure that the screw on the tripod is not at an angle when attaching or detaching the camera. You may damage the screw on the camera if you use excessive force when turning it. Also, the camera body and the rating label may be damaged or scratched if the camera is attached too tightly to the tripod.
- Read the operating instructions for the tripod carefully.

### About the strap

- If you attach a heavy interchangeable lens (more than about 1 kg) to the camera body, do not carry the camera by the strap. Hold the camera and the lens when carrying them.

## Message Display

Confirmation messages or error messages will be displayed on the screen in some cases. The major messages are described below as examples.

### **[THIS MEMORY CARD IS LOCKED]**

- The Write-Protect switch on the SD Memory Card and the SDHC Memory Card are moved to [LOCK]. Move the switch back to unlock it.

### **[NO VALID PICTURE TO PLAY]**

- Record a picture or insert a card with a recorded picture and then play it.

### **[THIS PICTURE IS PROTECTED]**

- Delete the picture after cancelling the protect setting.

### **[THIS PICTURE CANNOT BE DELETED]/[SOME PICTURES CANNOT BE DELETED]**

- Pictures not based on the DCF standard cannot be deleted.
  - If you want to delete some pictures, format the card after saving necessary data on a PC etc.

### **[NO ADDITIONAL SELECTIONS CAN BE MADE]**

- The number of pictures, which can be set at one time when [MULTI] has been selected for [DELETE MULTI] or [FAVORITE] has been exceeded.
  - Reduce the number of pictures set, and then repeat the operation.
- More than 999 favourites have been set.

### **[CANNOT BE SET ON THIS PICTURE]**

- [DPOF PRINT] cannot be set for pictures not based on the DCF standard.

### **[MEMORY CARD ERROR FORMAT THIS CARD?]**

- This card has a format which is not recognised by the camera.
  - Format the card again with the camera after saving necessary data on a PC etc.

### **[PLEASE CHECK THAT THE LENS IS ATTACHED CORRECTLY]**

- Check that the lens is attached correctly and then turn the camera off and on.
  - If the message persists, contact the dealer or your nearest Service Centre.

### **[MEMORY CARD PARAMETER ERROR]**

- Use a card compatible with this unit.
- You can only use an SDHC Memory Card if using cards with 4 GB or more capacity.

### **[MEMORY CARD ERROR PLEASE CHECK THE CARD]**

- An error has occurred accessing the card.
  - Insert the card again.
- Or try with a different card.

**[READ ERROR/WRITE ERROR  
PLEASE CHECK THE CARD]**

- An error has occurred reading or writing the data.
  - Turn the camera off and remove the card. Insert the card again and turn the camera on. Make sure the camera is turned off before removing or inserting the card to avoid damage.
- Or try with a different card.

**[A FOLDER CANNOT BE CREATED]**

- A folder cannot be created because there are no remaining folder numbers that can be used.
  - Format the card after saving necessary data on a PC etc. If you execute [NO.RESET] in the [SETUP] menu after formatting, the folder number is reset to 100.

**[PICTURE IS DISPLAYED FOR 4:3 TV]/[PICTURE IS DISPLAYED FOR 16:9 TV]**

- The video cable is connected to the camera.
  - Press [MENU/SET] if you want to delete this message at once.
  - Select [TV ASPECT] in the [SETUP] menu if you want to change the TV aspect.
- This message also appears when the USB connection cable is connected to the camera only. In this case, connect the other end of the USB connection cable to a PC or a printer.

**[PRINTER BUSY]/[PLEASE CHECK THE PRINTER]**

- The printer cannot print.
  - Check the printer.

**[THE LENS IS NOT ATTACHED PROPERLY.]**

- Detach the lens and then attach it again.











**[THIS BATTERY CANNOT BE USED]**

- Use the battery (DMW-BLB13E) that can be used with the unit.
- Detach the battery, and then attach it again. If the message is repeatedly displayed, contact the retailer where you purchased the unit.

## Functions that cannot be set or will not work under some conditions











Due to the camera's specifications, it may not be possible to set some of the functions or some functions may not work in some of the conditions under which the camera is used. The table below lists these functions and the corresponding conditions.

• For the functions which cannot be set or will not work in the Intelligent auto mode, refer to "Settings in Intelligent auto mode".

Functions that cannot be set or will not work	Main conditions in which the functions cannot be set or will not work
[AUTO REVIEW]	<ul style="list-style-type: none"> <li>• When the burst mode is set</li> <li>• When taking a picture of auto bracket</li> </ul>
[HIGHLIGHT]	<ul style="list-style-type: none"> <li>• Multi playback</li> <li>• Calendar playback</li> <li>• Playback zoom</li> </ul>
[POWER SAVE]	<ul style="list-style-type: none"> <li>• When using the AC adaptor</li> <li>• When connecting to a PC or a printer</li> <li>• During a slide show</li> </ul>
[AUTO LCD OFF]	<ul style="list-style-type: none"> <li>• When using the AC adaptor</li> <li>• When connecting to a PC or a printer</li> </ul>
[AUTO POWER LCD]	<ul style="list-style-type: none"> <li>• When playing back pictures</li> </ul>
Direction detection function	<ul style="list-style-type: none"> <li>• When non-compatible lenses are used</li> </ul>
[EX. OPT. ZOOM]	<ul style="list-style-type: none"> <li>• When set to [RAW<sub>1</sub>], [RAW<sub>2</sub>] or [RAW]</li> </ul>
[DIGITAL ZOOM]	<ul style="list-style-type: none"> <li>• Advanced scene mode</li> <li>• SCN mode</li> <li>• When Intelligent ISO is set</li> <li>• When set to [RAW<sub>1</sub>], [RAW<sub>2</sub>] or [RAW]</li> </ul>
[FLASH]	<ul style="list-style-type: none"> <li>•  mode</li> <li>• ,  and  in  mode</li> <li>•  in [SCENE MODE]</li> <li>•  mode</li> </ul>
[FLASH SYNCHRO]	<ul style="list-style-type: none"> <li>• Advanced scene mode</li> <li>• SCN mode</li> <li>•  mode</li> </ul>
Exposure compensation	<ul style="list-style-type: none"> <li>• <b>M</b> mode</li> <li>•  mode</li> </ul>
Burst	<ul style="list-style-type: none"> <li>• When flash emits light</li> </ul>
Auto Bracket	<ul style="list-style-type: none"> <li>• When flash emits light</li> <li>•  mode</li> <li>• When multi film bracket is set</li> </ul>



<b>[AF MODE]</b>	<ul style="list-style-type: none"> <li>• When using the digital zoom</li> </ul>
<b>AF tracking</b>	<ul style="list-style-type: none"> <li>• When set to [STANDARD] ( <b>B&amp;W</b> ), [DYNAMIC] ( <b>B&amp;W</b> ) or [SMOOTH] ( <b>B&amp;W</b> ) in film mode</li> <li>• When using the digital zoom</li> </ul>
<b>[MF ASSIST]</b>	<ul style="list-style-type: none"> <li>• When using the digital zoom</li> </ul>
<b>AF Lock</b>	<ul style="list-style-type: none"> <li>• When manual focus is set</li> </ul>
<b>AE Lock</b>	<ul style="list-style-type: none"> <li>• <b>M</b> mode</li> </ul>
<b>[WHITE BALANCE]</b>	<ul style="list-style-type: none"> <li>•  and  in  mode</li> <li>•  mode</li> <li>•  and  in  mode</li> <li>•  in  mode</li> <li>•  mode</li> <li>•  and  in [SCENE MODE]</li> <li>•  mode</li> </ul>
<b>[WB ADJUST.]</b>	<ul style="list-style-type: none"> <li>•  and  in  mode</li> <li>•  mode</li> <li>•  and  in  mode</li> <li>•  in  mode</li> <li>•  mode</li> <li>•  and  in [SCENE MODE]</li> <li>•  mode</li> </ul>
<b>White balance bracket</b>	<ul style="list-style-type: none"> <li>•  and  in  mode</li> <li>•  mode</li> <li>•  and  in  mode</li> <li>•  in  mode</li> <li>•  mode</li> <li>•  and  in [SCENE MODE]</li> <li>•  mode</li> <li>• When multi film bracket is set</li> <li>• When set to [RAW:1:1], [RAW:2:2] or [RAW]</li> </ul>
<b>[SENSITIVITY]</b>	<ul style="list-style-type: none"> <li>• Advanced scene mode</li> <li>• <b>SCN</b> mode</li> </ul>
<b>Intelligent ISO sensitivity</b>	<ul style="list-style-type: none"> <li>• <b>S</b> mode</li> <li>• <b>M</b> mode</li> <li>• Advanced scene mode</li> <li>• <b>SCN</b> mode</li> </ul>
<b>[FILM MODE]</b>	<ul style="list-style-type: none"> <li>•  mode</li> </ul>
<b>Multi film bracket</b>	<ul style="list-style-type: none"> <li>• Advanced scene mode</li> <li>• <b>SCN</b> mode</li> <li>•  mode</li> </ul>
<b>[PICTURE SIZE]</b>	<ul style="list-style-type: none"> <li>• When set to [RAW]</li> </ul>
<b>[METERING MODE]</b>	<ul style="list-style-type: none"> <li>• Advanced scene mode</li> <li>• <b>SCN</b> mode</li> </ul>
<b>[STABILIZER]</b>	<ul style="list-style-type: none"> <li>• When non-compatible lenses are used</li> </ul>

[I.EXPOSURE]	<ul style="list-style-type: none"> <li>• Advanced scene mode</li> <li>• SCN mode</li> </ul>
[ISO LIMIT SET]	<ul style="list-style-type: none"> <li>• M mode</li> <li>• Advanced scene mode</li> <li>• SCN mode</li> <li>•  mode</li> </ul>
[PRE AF]	<ul style="list-style-type: none"> <li>•  mode</li> <li>• Preview mode</li> <li>• When non-compatible lenses are used</li> </ul>
[DIRECT AF AREA]	<ul style="list-style-type: none"> <li>• Advanced scene mode</li> <li>• SCN mode</li> <li>•  mode</li> </ul>
[AF ASSIST LAMP]	<ul style="list-style-type: none"> <li>•  mode</li> <li>•  and  in  mode</li> <li>•  in [SCENE MODE]</li> </ul>
[FAVORITE]	<ul style="list-style-type: none"> <li>• Pictures taken with [RAW]</li> </ul>
[ROTATE]	<ul style="list-style-type: none"> <li>• Protected pictures</li> </ul>
[ROTATE DISP.]	<ul style="list-style-type: none"> <li>• Multi playback</li> <li>• Calendar playback</li> </ul>
[DPOF PRINT]	<ul style="list-style-type: none"> <li>• Pictures taken with [RAW]</li> </ul>
[RESIZE]	<ul style="list-style-type: none"> <li>• Pictures taken with [RAW<sup>+</sup>], [RAW<sub>+</sub>] or [RAW]</li> </ul>
[TRIMMING]	<ul style="list-style-type: none"> <li>• Pictures taken with [RAW<sup>+</sup>], [RAW<sub>+</sub>] or [RAW]</li> </ul>
[ASPECT CONV.]	<ul style="list-style-type: none"> <li>• Pictures taken with [RAW<sup>+</sup>], [RAW<sub>+</sub>] or [RAW]</li> <li>• Pictures taken with  or </li> </ul>

## Troubleshooting

First, try out the following procedures.

If the problem is not resolved, it may be improved by selecting **[RESET]** on the **[SETUP]** menu.

### Battery and power source

#### The camera cannot be operated even when it is turned on.

- The battery is not inserted correctly.
- The battery is exhausted.
- Charge the battery.
- AC adapter is not connected properly.

#### The LCD monitor turns off while the camera is turned on.

- Is the display set to Viewfinder?  
→ Press [LVF/LCD] button to switch to LCD monitor display.
- Is [AUTO LCD OFF] of the [ECONOMY] mode active?  
→ Press the shutter button halfway to cancel these modes.
- Is the LCD monitor switched off?  
→ Switch the display by pressing [DISPLAY].
- The battery is exhausted.
- Charge the battery.

#### The camera turns off immediately after it is turned on.

- The battery is exhausted.
- Charge the battery.
- If you leave the camera on, the battery will be exhausted.  
→ Turn the camera off frequently by using the [ECONOMY] mode etc.

#### This unit is turned off automatically.

- If you connect to a TV compatible with VIERA Link with a HDMI mini cable (optional) and turn off the power on the TV with the remote control for the TV, the power on this unit also turns off.  
→ If you are not using VIERA Link, set [VIERA Link] to [OFF].

#### The [CHARGE] lamp flashes.

- Is the temperature of the battery excessively high or low? If it is, it will take longer than usual to charge the battery or charging may remain incomplete.
- Are the terminals of the charger or battery dirty?  
→ Wipe off the dirt using a dry cloth.

## Recording

### **The picture cannot be recorded. The shutter does not activate.**

- Is the mode dial correctly set?
- Is the card inserted?
- Is there any memory remaining on the card?
  - Delete the pictures which are not necessary to increase the available memory.
- Is the subject focused?
  - At the time of purchase, the camera is set so that you cannot take a picture until the subject is brought into focus. If you want to be able to take a picture when you press the shutter button fully even if the subject is not focused, set [FOCUS PRIORITY] in the [CUSTOM MENU] menu to [OFF].

### **The recorded picture is whitish.**

- Picture might look whitish when lens or image sensor gets dirty with finger print or similar.
  - If the lens is dirty turn the camera off and then gently wipe the lens surface with a soft dry cloth.
  - Refer to (Cleaning) when the image sensor gets dirty.

### **The recorded picture is too bright or dark.**

- Check that the exposure is correctly compensated.
- Is the AE lock applied in inappropriate way?

### **2 or 3 pictures are taken at one time.**

- Unset the settings of white balance bracket.

### **The subject is not focused properly.**

- The subject is beyond the focus range of the camera.
- There is camera shake (jitter) or the subject is moving slightly.
- Is [FOCUS PRIORITY] in the [CUSTOM MENU] menu set to [OFF]?
  - In this case, the picture may not be properly focused even if [AFS] or [AFC] in focus mode is set.
- Is the AF lock applied in inappropriate way?

### **The recorded picture is blurred. The optical image stabilizer is not effective.**

- The shutter speed will become slower and the optical image stabilizer function may not work properly when taking pictures especially in dark places.
  - We recommend holding the camera firmly with both hands when taking pictures.
  - We recommend using a tripod and the self-timer when taking pictures with a slow shutter speed.

### **Taking pictures using white balance bracket is not possible.**

- Is the number of recordable pictures 2 or less?

**The recorded picture looks rough.  
Noise appears on the picture.**

- Is the ISO sensitivity high or the shutter speed slow?
  - Decrease the ISO sensitivity.
  - Increase the setting for [NOISE RED.] in [FILM MODE] or lower the setting for each of the items other than [NOISE RED.].
  - Take pictures in bright places.
  - Set the [LONG SHTR NR] to [ON].

**The brightness or the hue of the recorded picture is different from the actual scene.**

- If recording under fluorescent light, the brightness or the hue may change slightly when the shutter speed becomes fast. This occurs due to the characteristics of fluorescent light. It is not a malfunction.

**You can't compensate the exposure.**

- Are you in exposure compensation operation?
  - Press the front dial to switch to exposure compensation operation.

**Subject cannot be locked.  
(AF tracking not possible)**

- Set the AF area to the distinctive colour of the subject if there is a part that is different from the surrounding colour.

**Lens**

**Recorded image may be warped, or nonexistent colour is surrounding the subject.**

- Depending on the lens used, picture may be warped slightly or see colours in the edge depending on the zoom factor, due to the characteristics of the lens. Also, the peripherals of the image might look warped because the perspective is enhanced when the wide angle is used. This is not a malfunction.

**Flash**

**The flash is not activated.**

- Is the flash closed?
  - Slide the [ OPEN] lever to open the flash.

**The flash is activated 2 times.**

- The flash is activated 2 times. The interval between the first and second flash is longer when Red-eye reduction is set so the subject should not move until the second flash is activated.

## LCD monitor/Viewfinder

### The LCD monitor turns off although the camera is turned on.

- The LCD monitor turns off when [AUTO LCD OFF] is selected for the [ECONOMY] mode. [This does not happen when using the AC adaptor.]  
If the remaining battery power is low, it may take longer for the flash to be charged, and the time during which the LCD monitor is turned off may become longer.
- It will switch to viewfinder display if there is hand or object near the eye sensor.

### The LCD monitor/Viewfinder is too bright or dark.

- Adjust the brightness of the LCD monitor/viewfinder to a proper level.
- [POWER LCD] is activated.

### The picture is not displayed on the LCD monitor.

- Does the picture appear on the Viewfinder?  
→ Press [LVF/LCD] button to switch to LCD monitor display.
- Is the LCD monitor switched off?  
→ Switch the display by pressing [DISPLAY].

### LCD monitor and viewfinder does not switch when [LVF/LCD] is pressed.

- Is the [EXPO. SETTINGS] set to [SWITCH BY PRESSING THE LVF/LCD BUTTON]?
- It is only displayed on the LCD monitor when the camera is connected to a PC or printer.

### Black, red, blue and green dots appear on the LCD monitor.

- This is not a malfunction.  
These pixels do not affect the recorded pictures.

### Noise appears on the LCD monitor.

- In dark places, noise may appear to maintain the brightness of the LCD monitor. This does not affect the pictures you are recording.

### The LCD monitor flickers indoors.

- The LCD monitor may flicker for a few seconds after turning the camera on indoors under fluorescent light. This is not a malfunction.

### A flickering vertical line appears on the LCD monitor under fluorescent light.

- This is characteristic of MOS sensors which serve as the camera's pickup sensors.  
This is not a malfunction. This does not affect the pictures you are recording.

### You see red, green, or blue flashes when you move your eyes in the viewfinder, or when the camera is moved rapidly.

- This is a characteristic of the drive system of the viewfinder of this unit, and it is not a malfunction. There will be no problem with the recorded image.

## Playback

### The picture being played back is not rotated, or is rotated in an unexpected direction, when displayed.

- You can display the pictures without being rotated when [ROTATE DISP.] is set to [OFF].
- You can rotate pictures with the [ROTATE] function.
- You can only display the pictures rotated if you use a lens that supports the direction detection function and [ROTATE DISP.] is set to [ON].

### The picture is not played back.

- Did you press [▶]?
- Is the card inserted?
- Is there a picture on the card?
- Is this a picture whose file name has been changed in the PC? If it is, it cannot be played back by this unit.

### The folder number and the file number are displayed as [—] and the screen turns black.

- Is this a non-standard picture, a picture which has been edited using a PC or a picture which was taken by another make of digital camera?
- Did you remove the battery immediately after picture-taking or did you take the picture using a battery with a low remaining charge?
  - Format the data to delete the pictures mentioned above.  
(Other pictures will be deleted as well and it will not be possible to restore them.  
Therefore, check well before formatting.)

### Images with different date as recorded date are played back in the Calendar Playback.

- Is the clock in the camera set properly?
- Images edited on a PC or images recorded on other cameras might display a different date to the recorded date during the Calendar Playback.

### White round spots like soap bubbles appear on the recorded picture.

- If you take a picture with the flash in a dark place or indoors, white round spots may appear on the picture caused by the flash reflecting of particles of dust in the air. This is not a malfunction.  
A characteristic of this is that the number of round spots and their position differ in every picture.



### [THUMBNAIL IS DISPLAYED] appears on the screen.

- Is it a picture that has been recorded with other equipment? In such cases, these pictures may be displayed with a deteriorated picture quality.

## TV, PC and printer

### The picture does not appear on the television.

- Is the camera connected to the TV correctly?  
→ Set the TV input to external input mode.
- Output from the [HDMI] socket is not possible when it is connected to the PC or the printer.  
→ Connect it only to the TV.

### The display areas on the TV screen and the camera's LCD monitor are different.

- Depending on the TV model, the pictures may be extended horizontally or vertically or they may be displayed with their edges cut off.

### The picture is not displayed fully on the TV.

- Check [TV ASPECT] setting.

### VIERA Link does not work.

- Is it connected properly with the HDMI mini cable (optional)?  
→ Confirm that the HDMI mini-cable (optional) is firmly fitted.
- Is the [VIERA Link] on this unit set to [ON]?  
→ Depending on HDMI terminal of the TV, the input channel may not switch automatically. In this case, use the remote control for the TV to switch input. (For details on how to switch input, please read the operating instructions for the TV.)  
→ Check the VIERA Link setting on the connected device.  
→ Turn the power to the unit off and then back on again.  
→ Set [VIERA Link] to [Off] on the TV and then turn it back to [On]. (Refer to the operating instructions of the TV for details.)

### The picture cannot be transferred when the camera is connected to a PC.

- Is the camera connected to the PC correctly?
- Is the camera recognised by the PC correctly?  
→ Set to [PC] in [USB MODE].

### The card is not recognised by the PC.

- Disconnect the USB connection cable. Connect it again while the card is inserted in the camera.

### The picture cannot be printed when the camera is connected to a printer.

- Pictures cannot be printed using a printer which does not support PictBridge.  
→ Set to [PictBridge(PTP)] in [USB MODE].

### The ends of the pictures are cut at printing.

- When using a printer with a trimming or borderless printing function, cancel this function before printing. (For details, refer to the operating instructions for the printer.)
- When you order photo studios to print pictures, ask the photo studio if the pictures can be printed with both ends.





## Others

### There is a sound from lens unit.

- It is a sound of lens movement or aperture operation when the power is turned [ON] or [OFF], and it is not a malfunction.
- You may hear a sound from the lens and image in the LCD monitor may suddenly change when the brightness has changed by zoom operation or moving the camera, but there is no effect on recording.  
The sound is caused by the automatic adjustment of the aperture. This is not a malfunction.

### An unreadable language was selected by mistake.

- Press [MENU/SET], select the [SETUP] menu icon [] and then select the [] icon to set the desired language.

### Part of the picture is flashing in black and white.

- This is a highlight function showing the white saturated area.
- Is the [HIGHLIGHT] set to [ON]?

### A red lamp sometimes turns on when the shutter button is pressed halfway.

- In dark places, the AF assist lamp lights red to make it easier to focus on a subject.

### The AF assist lamp does not turn on.

- Is [AF ASSIST LAMP] on the [CUSTOM MENU] menu set to [ON]?
- The AF assist lamp does not turn on in bright places.

### The camera becomes warm.

- The surface of the camera and the reverse side of the LCD monitor may become warm during use. This does not affect the performance or quality of the camera.

### The clock is reset.

- If you do not use the camera for a long time, the clock may be reset.  
→ When the message [PLEASE SET THE CLOCK] appears, set the clock again. When you take a picture before setting the clock, [0:00 0. 0. 0] is recorded.

### The file numbers are not recorded consecutively.

- When you perform an operation after taking a certain action, the pictures may be recorded in folders with different numbers from the ones used prior to the operation.

### The file numbers are recorded in ascending order.

- If the battery was inserted or removed without first turning the camera's power off, the folder and file numbers for the pictures taken will not be stored in the memory. When the power is then turned back on and pictures are taken, they may be stored under file numbers which should have been assigned to previous pictures.

### Age is not displayed correctly.

- Check the clock and birthday settings.

# 6 Service Mode

## 6.1. Error Code Memory Function

### 1. General description

This unit is equipped with history of error code memory function, and can be memorized 16 error codes in sequence from the latest. When the error is occurred more than 16, the oldest error is overwritten in sequence.

The error code is not memorized when the power supply is shut down forcibly (when the unit is powered on by the battery, the battery is pulled out) because the error code is memorized to FLASH ROM when the unit is powered off.

### 2. How to display

The error code can be displayed by the following procedure:

Before perform the error code memory function, connect the AC adaptor or insert the battery and insert the SD memory card.

#### • 1. The temporary cancellation of initial setting:

Set the Drive mode lever to [ SINGLE ].

While keep pressing [ DISPLAY ] and [ FILM MODE ] buttons simultaneously, turn the Power on.

#### • 2. The display of error code:

Press [ FILM MODE ], [ MENU/SET ] and “[ LEFT ] of Cursor buttons” simultaneously with the step 1 condition.

The display is changed as shown below when the above buttons is pressed simultaneously.

Normal display → Error code display → Operation history display → Normal display → .....

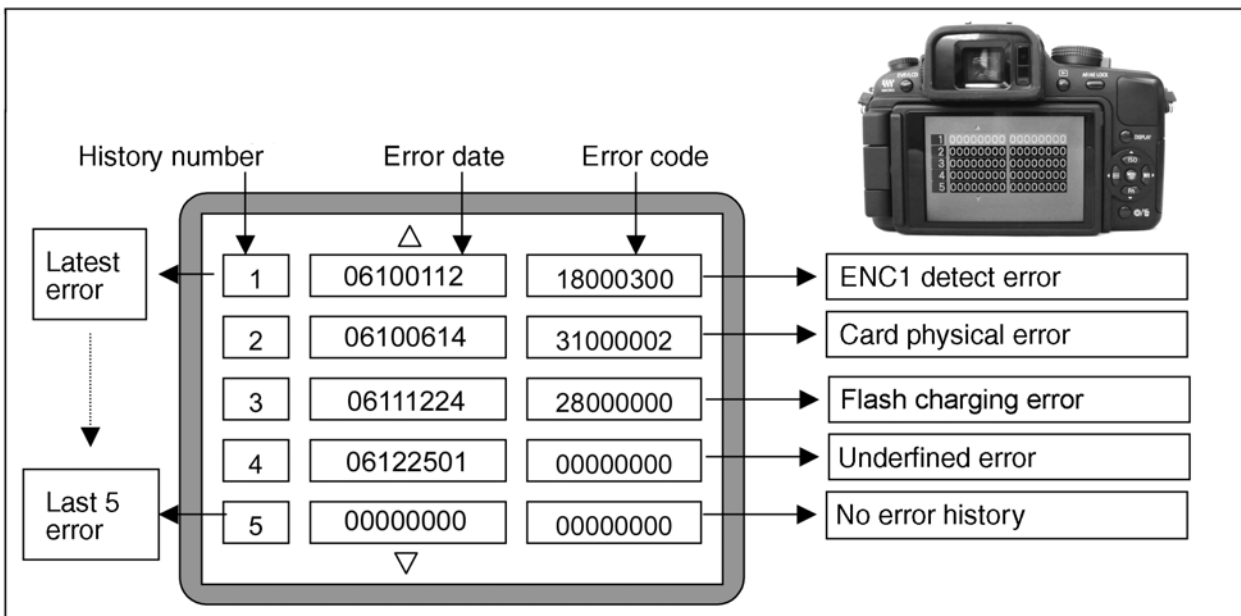

Example of Error Code Display

#### • 3. The change of display:

The error code can be memorized 16 error codes in sequence, however it is displayed 5 errors on the LCD.

Display can be changed by the following procedure:

“[ UP ] or [ DOWN ] of Cursor buttons” : It can be scroll up or down one.

“[ LEFT ] or [ RIGHT ] of Cursor buttons” : It can be scroll up or down every 5 error, when the same button is pressed in twice. (When it is pressed at once, skip two data line. When it is pressed in twice, skip three data line.)

#### • 4. How to read the error date:

The error date code is displayed from the left in order at the year, month, day, time.

Error date information is acquired from "Clock setting" information when the error occurs. When the clock is not setting, it is displayed as "00000000".

• **5. How to read the error code:**

One error code is displayed for 8 bit, the contents of error codes is indicated the table as shown below.

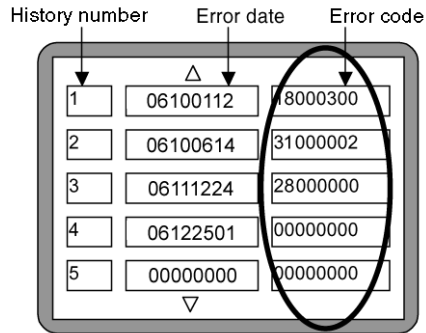

Attribute	Main item	Sub item	Error code		Contents
			High 4 bits	Low 4 bits	
LENS	Lens	Communication	18*0	0000   FFFF	Lens communication error.
HARD	VENUS A/D	Flash	28*0	0000	Flash charging capacitor did not been fully charged within 20 seconds.
	FLASH ROM	Data Area	2B*0	0001	Flash ROM data reading error is detected when the unit turns ON.
		Program Area		0005	Firmware update error.
	SYSTEM IC	Initialization	2C*0	0001	Clock IC initialization failure error.
SOFT	CPU	Reset	30*0	0001   FFFF	System error (NMI reset).
	Recording Media	SD Memory Card	31*0	0001	SD memory card logic error. SD memory card format error. When it is detected, [MEMORY CARD ERROR FORMAT THIS CARD?] is displayed on the screen.
				0002	SD memory card physical error. During formatting the SD memory card, there is no response from the card. If the mini-SD memory card is used, check the SD memory card adaptor.
				0004	SD memory card writing error. Check the SD memory card. It might be damage one.
	Lens	ZOOM	3C*0	0000	Zoom process does not be completed.
	Camera	System	3B*0	0000	Initialization failure.
				3E*0	0001
	System	System	35*0	0002	Failure of the returning operation to the home position.
				0001   FFFF	System error.
	35*1, 35*2	0000	System error (in recording pre-process).		

**About "\*" indication in the above table:**

The third digit from the left is different as follows.

- In case of 0 (example: 18**0**01000)

When the third digit from the left shows "0", this error occurred under the condition of INITIAL SETTINGS has been completed.

It means that this error is occurred basically at user side.

- In case of 8 (example: 18**8**01000)

When the third digit from the left shows "8", this error occurred under the condition of INITIAL SETTINGS has been released.

(Example; Factory assembling-line before unit shipment, Service mode etc.)

It means that this error is occurred at service side.

• **6. How to returned to Normal Display:**

Turn the power off and on, to exit from Error code display mode.

**NOTE:**

The error code can not be initialized.

# 7 Troubleshooting Guide

## 1. INITIAL (DEFAULT) STATUS OF THE LENS UNIT

The Lens unit which is supplied as a standard accessory for this camera unit (H-FS014045) shows the following status when the Lens is detached from the Camera unit.

NOTE: Although the lens unit is attached it shows the same condition when the Camera turns off.

- [1]. ZOOM RING ..... When the Zoom ring is rotated, Zoom condition is changing accordingly.  
[Focal length : 14mm to 45mm [35mm film camera equivalent: 28mm to 90mm]]
- [2]. FOCUS RING ..... The Focus condition does not change although Focus ring is rotated. (Free rotation.)

## 2. INITIAL INSPECTION TIPS (BEFORE DETERMINE THE UNIT BEING FAULTY/DEFECTIVE):

Since this unit is equipped with various functions/settings, some phenomenon/effect might be caused by miss usage of function and/or settings.

It might be made a miss-judgement caused by miss usage of function & settings although the unit is working properly without fault.





Therefore, check/confirm the followings before concluding/determine the unit being faulty/defective.

NOTE: Refer to the Operating Instructions carefully.

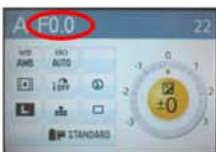

Also, useful hint/tips for this unit is available at following URL, and is updated frequently.  
<http://panasonic.jp/support/global/cs/dsc/>

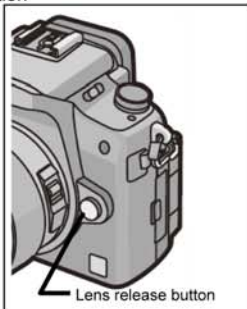

**If it is hard to determine whether the resolution is out of specification or not, proceed the "RESOLUTION INSPECTION", before replacing the LENS MAIN BLOCK UNIT and/or MOUNT BOX BLOCK. (The unit might be mishandling, dropping or others.)**

### [1]. [LENS RELATIVES]

TITLE	ITEMS	DESCRIPTION
LENS	Aperture size does not changed. (Although aperture value is changed, the physical size of aperture is never changed.)	*Although aperture value is changed, the physical size of aperture is never changed (It keeps the maximum aperture condition) until the shutter release button is fully released. (There is no "aperture stopping down" button and/or function. But instead, there is a shutter speed preview mode.) !! [CUSTOM] menu (2/5) ---- [PREVIEW HOLD] (ON/OFF)
	The Aperture condition does not changed. (Aperture value shows "F0.0")	*The Lens & Body are communicating (serial communication) through mount contacts (11pins). *Confirm that lens & body mount contacts are not dirty. *While keep pressing the [Lens release] button, it makes same situation that Lens does not attached. *Although lens is attached to the body, the Aperture value shows "F0.0" when the communication error is occurred. Also, when the firmware version confirmation mode is executed, the [ - - ] is displayed as Lens firmware version.  Aperture value is fixed at [F0.0]  Firmware version shows [LENS FIRMWARE : - -]  Lens release button
	Although the Focus ring is rotating, it does not change the Focus condition.	*The Focus condition is never changed although focus ring is rotated when the Focus mode dial is positioned at AFS or AFC. (When the [AF + MF] is set to [ON], it is able to fine adjust the focus manually by rotating the focus ring while AF lock.) !![CUSTOM] menu (3/5)----- AF + MF (ON/OFF)
	No released without lens attachment.	*It is able to release the shutter button without attaching the lens unit. !! [CUSTOM] menu (5/5) ---- [SHOOT W/O LENS] (ON/OFF)
	The Dusty and/or dirty of the Lens	*Define the location of the dirt / dust of the lens first, whether it is outside surface of the lens or not. If it is outside surface of the lens, order the following procedure in steps. STEP-1. Blow off the dust certainly with Hand Blower. STEP-2. Clean and wipe up the Lens surface by using the Lens cleaning Kit (VFK1900BK). (Read/consult the instruction sheet being included in the Lens cleaning Kit in details.)  [ Wiping up the lens surface ] Like drawing the circle, wipe up the lens surface centre towards to outside slowly.
It does not become the Shutter speed [B] (Bulb) mode.	*It is only able to select the shutter speed to [B](Bulb) when mode dial is set to [M] (Manual) and drive mode lever is [SINGLE] position. ([B] mode: the shutter stays open while the shutter button is pressed fully (up to about 4 minutes). The shutter closes if you release the shutter button.)	

[2]. [BODY RELATIVES]

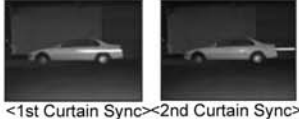



TITLE	ITEMS	DESCRIPTION
FOCUS	The picture is out of focus although the focus is adjusted in MF mode at once.	<ul style="list-style-type: none"> <li>*In the following conditions, the focus may be out of focus, no matter the kind of subject. Therefore, adjust the focus again by rotating the Focus ring.</li> <li>*After "in-focus" condition, Zoom condition has been changed.</li> <li>*Power switch is turned OFF and ON again.</li> <li>*After releasing the Power save.</li> </ul>
	Focus does not become in focus condition.	<ul style="list-style-type: none"> <li>*If the shooting distance is less than the Minimum requirement distance for focus, the focus may not be brought into focus, no matter the kind of subject.</li> </ul> 
	MF(Manual Focus)ASSIST does not work.	<ul style="list-style-type: none"> <li>*The MF assist function is that the certain area image is able to enlarge 5 times to make easier to focus. (It is enlarged from 5times to 10 times when the front dial is rotated clockwise.)</li> <li>*It does not activated if the [Focus Mode Dial] is positioned other than [MF] position.</li> <li>*It does not activated when using the Digital Zoom.</li> <li>*It does not activated if [MF ASSIST] is set to OFF.</li> <li>!! [CUSTOM] menu (4/5) ---- [MF ASSIST] (ON/OFF)</li> <li>(To display the MF assist, press Left cursor button then press [MENU/SET].)</li> </ul>
	Face detection does not work.	<ul style="list-style-type: none"> <li>*Select AF mode to face detection. (In [IA]mode, it is automatically assigned according with scene.) (Press the left side cursor button to display the AF mode menu.)</li> <li>*It does not activated when using the Digital Zoom.</li> <li>*It does not activated if the focus mode dial set to MF.</li> </ul>
	The subject is not focused properly.	<ul style="list-style-type: none"> <li>*When get a fingerprint, dirt on the lens surface, resulting in the subject being out of focus.</li> <li>*The subject is beyond the focus range of the camera.</li> <li>*There is camera shake (jitter) or the subject is moving slightly.</li> <li>*The focus indication green mark is lights at the top right hand corner on the LCD when the subject is focused.</li> <li>*The shutter speed will become slower and the optical image stabilizer function may not work properly when taking pictures especially in dark places.</li> </ul>
	Focus does not change.	<ul style="list-style-type: none"> <li>*Focus &amp; Exposure condition is locked when the [AFL / AEL] button is pressed under the condition of [AF / AE LOCK HOLD] is "On".</li> <li>!![CUSTOM] menu (2/5)-----AF / AE LOCK HOLD (ON/OFF)</li> <li>*It can be reset when [AFL/AEL] button is pressed again.</li> </ul>
	Although [AF / AE LOCK] button is pressed, it does not hold the Focus, only Exposure is locked.	<ul style="list-style-type: none"> <li>*Focus does not hold even if [AF/AE Lock] button is pressed if the [AF/AE LOCK HOLD] is selected [AE].</li> <li>!![CUSTOM] menu (2/5)-----AF / AE LOCK (AE, AF, AF/AE)</li> <li>*In the Manual Focus condition, It is only worked as [AE lock] function.</li> </ul>
	It does not turn to the "AFC" mode. (Motion prediction does not work.)	<ul style="list-style-type: none"> <li>*Confirm the setting position of the focus mode dial (AFS / AFC / MF).</li> <li>*Although AFC is effective with burst mode, the focus is fixed on the first picture when subject is dark.</li> </ul>
Flash	GN (Guide Number) of the Built in Flash (Specification GN11.0)	<ul style="list-style-type: none"> <li>*By referring the specification of the built-in flash is GN11.0 (equivalent)</li> <li>* There is a formula : <math>f\_value \times Flash\ reachable\ distance = GN [ISO100]</math></li> <li>(In case of: H-FS014045)</li> <li>ISO100 / Wide edge Aperture is F3.5 / Flash reachable distance is 3.1m</li> <li>[3.5 X Approx 3.1 = 10.85---- "GN11"]</li> <li>ISO100 / Tele edge Aperture is F5.6 / Flash reachable distance is 1.9m</li> <li>[5.6 X Approx 1.9 = 10.6---- "GN11"]</li> </ul>
	Some of the Flash setting(s) are not able to select.	<ul style="list-style-type: none"> <li>*In accordance with the [REC] mode and [FLASH SYNC.] mode, selectable flash settings may be differ.</li> </ul>
	[AUTO BRACKET] does not work.	<ul style="list-style-type: none"> <li>*Only one picture can be taken when the Flash is fired.</li> </ul>
	The subject is too bright / too dark with Flash.	<ul style="list-style-type: none"> <li>*Confirm that the picture is taken within Flash range or not.</li> <li>*Confirm that flash output settings.</li> <li>!![REC] menu (2/4) -----FLASH ADJUST. (1/3 EV Step, -2EV to +2EV)</li> </ul>
	The Flash adjustment does not effect.	<ul style="list-style-type: none"> <li>*Confirm that the picture is taken within Flash range or not.</li> </ul>
White round spots appear on the recording picture	<ul style="list-style-type: none"> <li>*If you take a picture with flash in a dark place or indoors, white round spots may be appear on the picture caused by the flash reflecting of particles of dust in air. This is not a malfunction.</li> <li>*A characteristic of this is that the number of round spots and their position differ in every picture.</li> </ul> 	

TITLE	ITEMS	DESCRIPTION
Flash	Colour is strange when the Flash is fired.	<p>*The colour of the subject which is other than Flash reachable distance is not coverage of white balance.</p> <p>*Confirm that [WB Adjustment] setting condition. (Press the cursor [RIGHT] (WB) button, then press the cursor [DOWN] button, in order to execute the [WB ADJUST.] screen.)</p> <p>*It also effects to the Flash recording mode as well.</p> 
	The appearance of the light source is strange. (The light source appears ahead the subject.)	<p>*Normally, the light source appears ahead the subject. (This is the effect of the 1st curtain synchro.)</p> <p>*The Flash synchro mode can be selected. !![REC]menu (2/4) ---- [FLASH SYNC.](1ST / 2ND)</p> 
EXPOSURE	The Exposure condition can not be changed	<p>*Focus &amp; Exposure condition is locked when the [AFL / AEL] button is pressed under the condition of [AF / AE LOCK HOLD] is "On". !![CUSTOM] menu (2/5)-----AF / AE LOCK HOLD (ON/OFF)</p> <p>*It can be reset when [AFL/AEL] button is pressed again.</p>
	Although [AFL/AEL] button is pressed, only focus is locked. (AE is not locked)	<p>*Exposure does not hold even if [AF/AE Lock] button is pressed if the [AF/AE LOCK] is set to [AF]. !![CUSTOM] menu (2/5)-----[AF/AE LOCK] settings (AF, AE, AF/AE )</p> <p>*In the Manual Focus condition, It is only worked as [AE lock] function, regardless any settings.</p>
	The pictures recorded with [AUTO BRACKET] function are too dark/bright.	<p>*The [AUTO BRACKET] is selected after setting the [EXPOSURE COMPENSATION], the compensated value is effected for its reference value.</p>
	The Exposure condition is changed extremely.	<p>*Spot metering mode is measuring only the limited narrow area on the centre of the screen.</p> <p>*Confirm the setting condition of [EXPOSURE COMPENSATION] (1/3 EV Step, -3EV to +3EV) !![CUSTOM] menu (3/5)-----FOCUS PRIORITY (ON/OFF)</p>
CAPTURING	Although shutter is released, no picture is captured.	<p>*Although the shutter button is fully pressed, it can not take a picture until the subject is not focused. (It is able to take a picture when the Focus Priority turns [OFF] although focus condition does not perfect.) OFF is gives priority to the best time to take a picture. !![CUSTOM] menu (3/5)-----FOCUS PRIORITY (ON/OFF)</p>
	[AUTO BRACKET] does not work.	<p>*Only single picture is able to captured when flash is fired.</p> <p>*It can not be used in My colour mode.</p> <p>*The exposure may not be compensated with auto bracket depending on the brightness of the subject.</p>
COLOUR REPRODUCTION	Colour is strange.	<p>*There is a possibility that [Finely adjusting the white balance] is selected/shifted.</p> <p>*Confirm that [WB Adjustment] setting condition. (Press the cursor [DOWN] (WB) button, then after choosing the WB mode press the cursor [DOWN](WB) button, in order to execute the [WB ADJUST.] screen.)</p> <p>*It is resumed/memorized although power turns off/on.</p> <p>*Confirm that Film mode, especially, [MY FILM1 &amp;2] settings.</p> 
	Colour is strange. (With Flash)	<p>*The flash light does not reach enough to the subject due to the over than flash reachable distance. In this case, white balance may be other than its coverage.</p>
	The colour is strange (On PC monitor/ Printout image.)	<p>*There is a possibility that the picture is captured with [AdobeRGB] setting. !! [REC] menu (4/4) ---- [COLOUR SPACE] (sRGB/AdobeRGB)</p> <p>*To proceed proper colour reproduction for AdobeRGB, the AdobeRGB capable PC and Printer are necessary.</p> <p>*In accordance with PC environment, it may not be displayed properly when the picture is re-sized with business software.</p>
POWER	The Power is turned off.	<p>*Confirm that the setting condition of [POWER SAVE]. (If the camera has not been used for the time selected on the setting, the power turns off automatically.) !![SETUP] menu (2/5)-----[ECONOMY] [POWER SAVE](OFF/1MIN./2 MIN./5 MIN./10 MIN.)</p>
DISPLAY	Abnormal Picture Effect. Certain part of the picture is flashing in Black & White.	<p>*Confirm that the setting condition of [HIGHLIGHT]. !![SETUP] menu (1/5)-----[HIGH LIGHT] (ON/OFF)</p> <p>The white saturated areas appear blinking in Black and White.</p>
	Firmware version	<p>*Confirm that the firmware versions of the camera and lens to be checked. !![SETUP] menu (4/5)-----[VERSION DISP.]</p>

## 8 Service Fixture & Tools

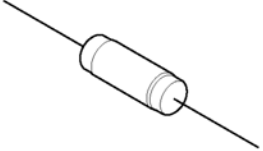
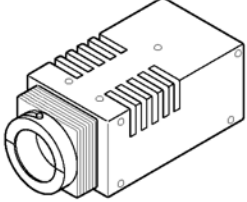
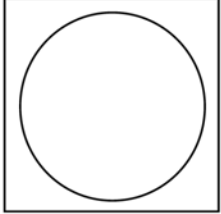
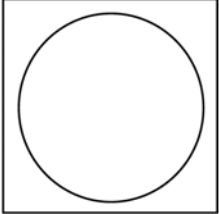
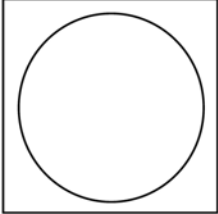
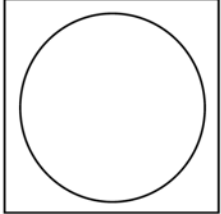
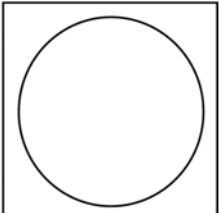
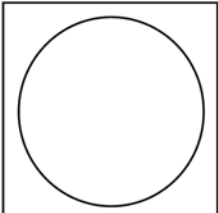
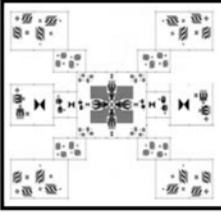
### 8.1. Service Fixture and Tools

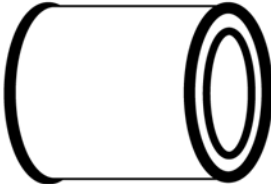
The following Service Fixture and tools are used for checking and servicing this unit.

Resistor for Discharging ERG5SJ102	LIGHT BOX VFK1164TDVLB	ND FILTER RFKZ0513
 <p>An equivalent type of Resistor may be used.</p>	 <p>※ with DC Cable</p>	
CC FILTER 1 RFKZ0511	CC FILTER 2 RFKZ0512	LB FILTER 1 RFKZ0520
		
LB FILTER 2 RFKZ0521	GRAY CARD RFKZ0506	RESOLUTION CHART RFKZ0510
		 <p>※ Supplied as divided chart parts. (Assemble it before use.)</p>
Lens Cleaning Kit (BK) VFK1900BK	NAME RING FIXTURE RFKZ0507	TORQUE DRIVER RFKZ0456
 <p>* Only supplied as 10 set/box.</p>		 <p>Spec.:2-30cN · m (Equiv.0.2-3kgf/cm)</p>
Driver VFK1390		
		

## 8.2. Clean Box

### 8.2.1. Servicing the Unit

To keep dustproof environment when repairing the unit, CLEAN BOX is recommended.

### 8.2.2. Introduction of Clean box

One of our recommended clean box is as shown below. (less than class 10,000 Federal Standard 209D).

It consists of "Air clean unit" and "Clean hood".

As for the "Air clean unit", refer to the "Jig Information" on the "Support Information from NWBG/VDBG-AVC" web-site in "TSN system".

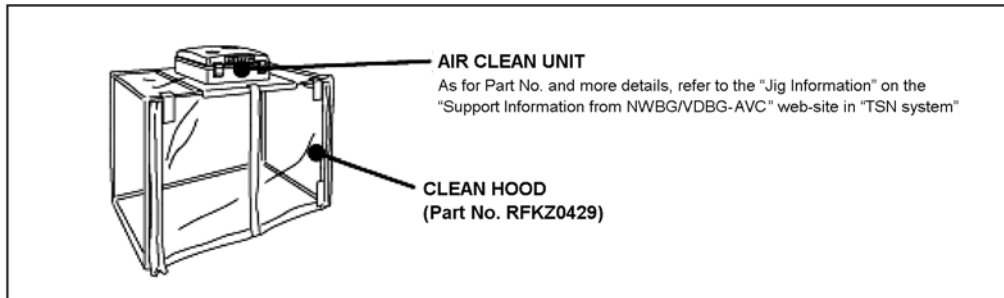



### 8.3. Service Position

This Service Position is used for checking and replacing parts. Use the following Extension cables for servicing.

Table S1 Extension Cable List

No.	Parts No.	Connection	Form
1	VFK1441	FP9001 (MAIN) - FP7701 (AF ASSIST), FP7351 (REMOTE), FP7300 (LP SW)	8PIN 0.5 FFC
2	RFKZ0477	FP9006 (MAIN) - LVF UNIT	45PIN 0.3 FFC
3	VFK1950	FP9005 (MAIN) - FP7201 (LCD IF)	33PIN 0.3 FFC
4	VFK1576DC202	P9003 (MAIN) - CL4901/CL4902 (HINGE SW)	2PIN CONNECTOR
5	VFK1286	FP9008 (MAIN) - REAR OPERATION UNIT	16PIN 0.5 FFC
6	VFK1576DC202	P8504 (FLASH) - TOP CASE UNIT	2PIN CONNECTOR
7	RFKZ0359	P8503 (FLASH) - TOP CASE UNIT	2PIN CONNECTOR
8	VFK1282	FP9010 (MAIN) - P8507 (FLASH)	22PIN 0.5 FFC

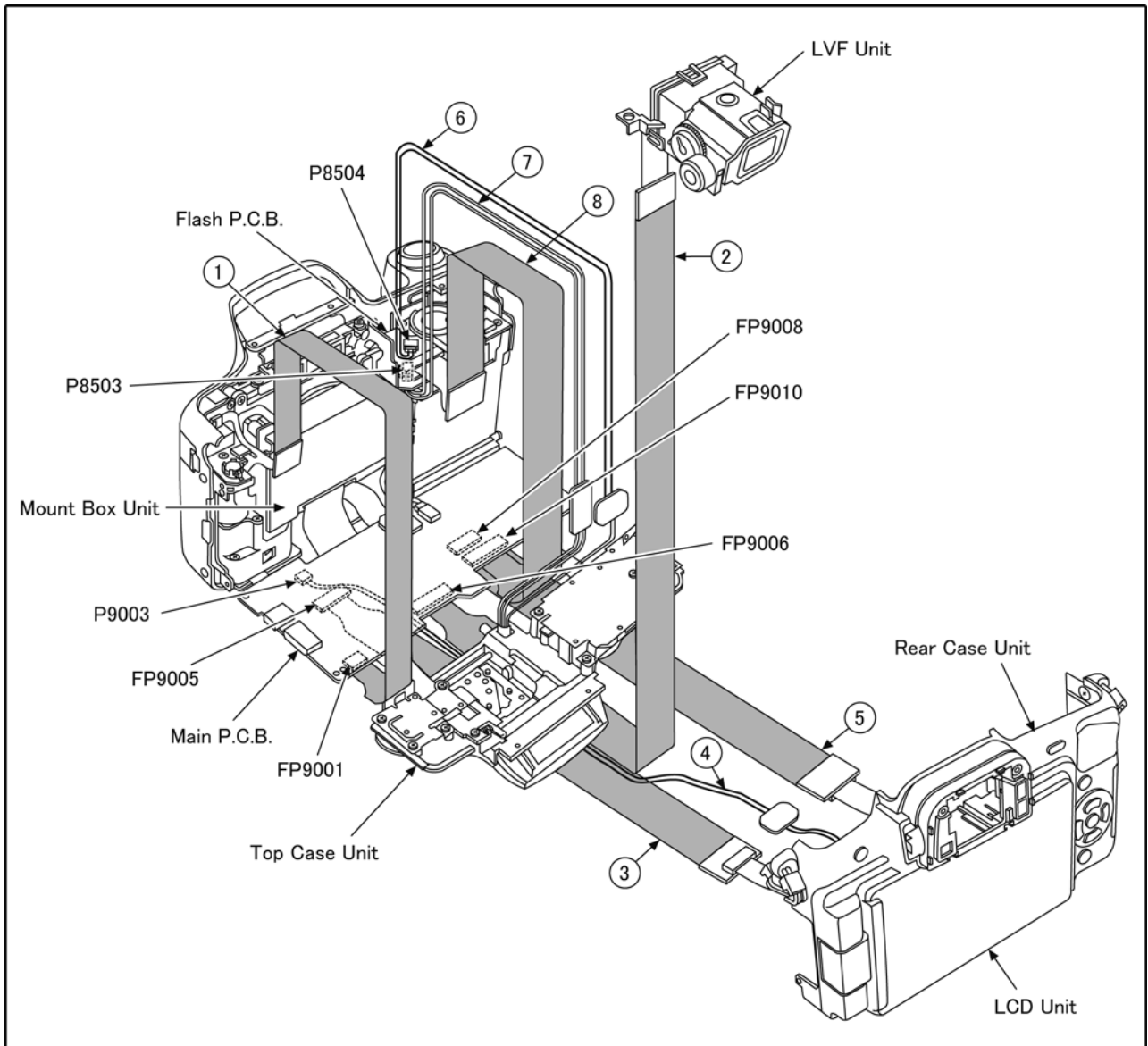

**CAUTION-1. (When servicing FLASH SUB PCB)**

1. Be sure to discharge the capacitor on FLASH SUB PCB.  
Refer to "HOW TO DISCHARGE THE CAPACITOR ON FLASH SUB PCB".  
The capacitor voltage is not lowered soon even if the AC Cord is unplugged or the battery is removed.
2. Be careful of the high voltage circuit on FLASH SUB PCB.
3. DO NOT allow other parts to touch the high voltage circuit on FLASH SUB PCB.

# 9 Disassembly and Assembly Instructions

## 9.1. Disassembly Flow Chart

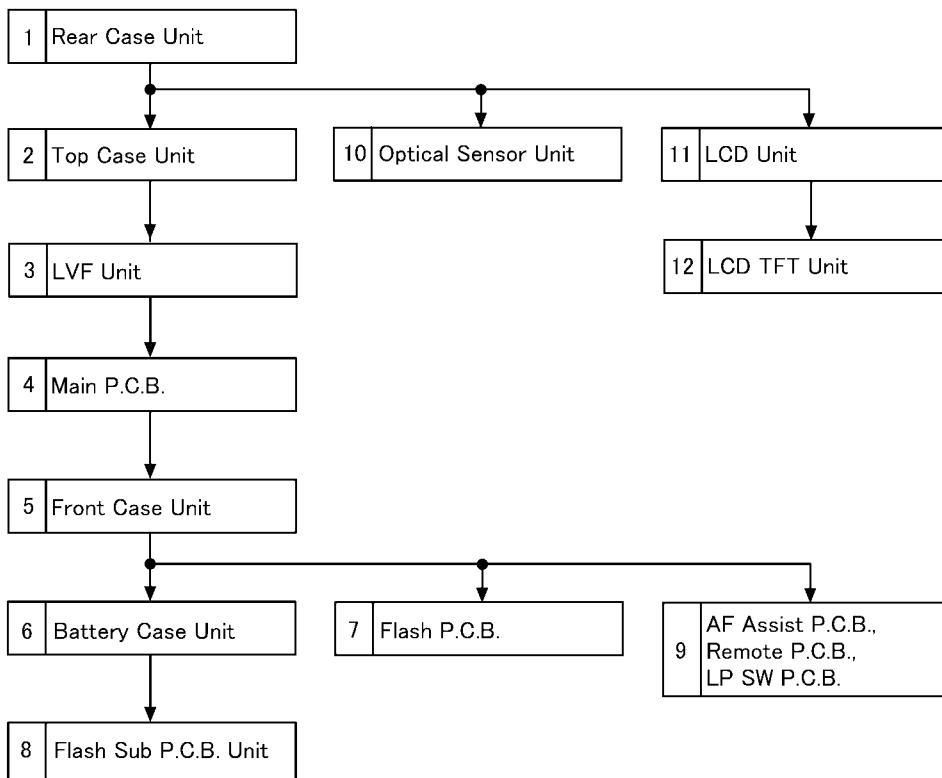

## 9.2. PCB Location

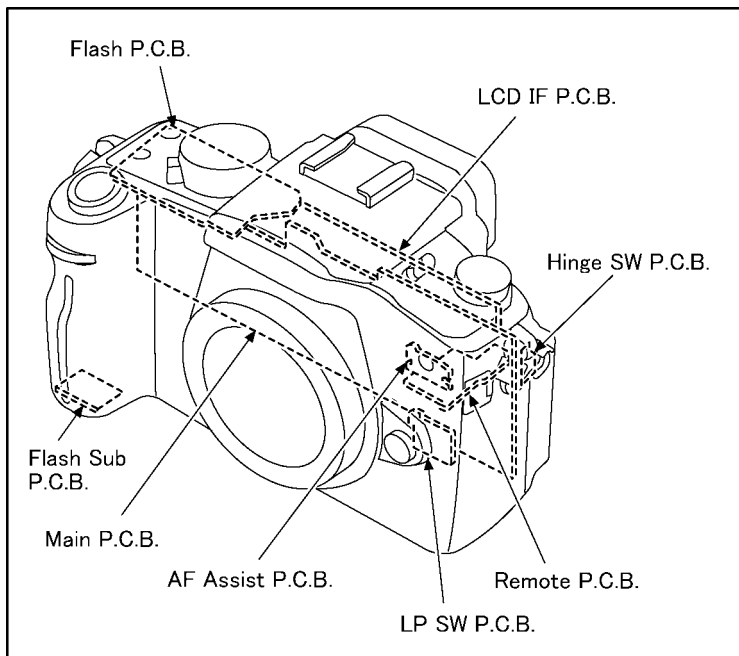

### 9.3. Disassembly Procedure

No.	Item	Fig	Removal
1	Rear Case Unit	(Fig. D1)	Card Battery 3 Screws (A) 1 Screw (B) 3 Screws (C) 1 Screw (D) 3 Screws (E)
		(Fig. D2)	Eye Cup Unit 2 Screws (F) FP9005(Flex) FP9008(Flex) P9003(Connector) Rear Case Unit
2	Top Case Unit	(Fig. D3)	2 Screws (G) FP9002(Flex) FP9007(Flex) P8503(Connector) P8504(Connector) Top Case Unit
3	LVF Unit	(Fig. D4)	2 Screws (H) FP9006(Flex) LVF Unit
4	Main P.C.B.	(Fig. D5)	2 Screws (I) 1 Screw (J) Jack Holder FP9001(Flex) FP9003(Flex) FP9004(Flex) FP9009(Flex) FP9010(Flex) P9001(Connector) Main P.C.B.
5	Front Case Unit	(Fig. D6)	1 Screw (K) Main P.C.B. Flex Plate FP8505(Flex) Body Cap 3 Screws (L) 1 Screw (M) 1 Screw (N)
		(Fig. D7)	Front Case Unit
6	Battery Case Unit	(Fig. D8)	2 Screws (O) 1 Screw (P) Battery Case Unit
7	Flash P.C.B.	(Fig. D9)	2 Screws (Q) P8506(Connector) Buzzer Solder (4 points) P8502(Connector) Flash P.C.B.
8	Flash Sub P.C.B. Unit	(Fig. D10)	Kapton Tape Flash PI Tape 1 Screw (R) 1 Locking tab Battery Lock Spring Flash Sub P.C.B. Unit

No.	Item	Fig	Removal
9	AF Assist P.C.B. Remote P.C.B. LP SW P.C.B.	(Fig. D11)	FP7701(Flex) 1 Screw (S) AF Light Case AF Assist P.C.B.
		(Fig. D12)	2 Screws (T) 3 Screws (U) Remote Holder FP7300(Flex) FP7351(Flex) Remote P.C.B. LP SW P.C.B.
10	Optical Sensor Unit	(Fig. D13)	Flex 1 Screw (V) 1 Screw (W) Eye Piece Plate 1 Locking tab Optical Sensor Unit
11	LCD Unit	(Fig. D14)	2 Screws (X) FPC Cover 1 Hanging part
		(Fig. D15)	2 Ribs Hinge Arm Cover Top Hinge Arm Cover Bottom 2 Screws (Y) LCD Unit
12	LCD TFT Unit	(Fig. D16)	2 Screws (a) 2 Screws (b) LCD Case Bottom LCD Hinge Unit LCD IF P.C.B. LCD BL Bezel Sheet LCD Shield Case Unit LCD Shield Case Up Unit LCD TFT Unit

### 9.3.1. Removal of the Rear Case Unit

**NOTE:**

When servicing and reassembling, remove the card and battery from the unit.

- Card
- Battery

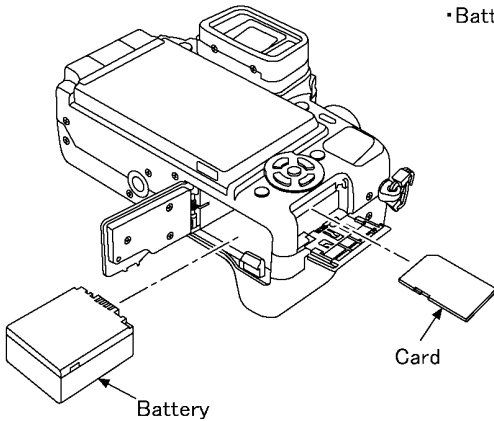

- Screw(A) × 3
- Screw(B) × 1
- Screw(C) × 3
- Screw(D) × 1
- Screw(E) × 3

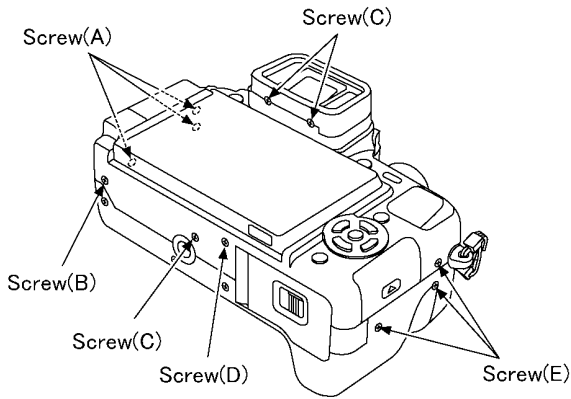

Screw(A)  4mm BLACK	Screw(B)  2mm BLACK	Screw(C)  3mm BLACK
Screw(D)  5mm BLACK	Screw(E)  6mm BLACK	

(Fig. D1)

- Eye Cup Unit
- Screw(F) × 2
- FP9005(Flex)
- FP9008(Flex)
- P9003(Connector)

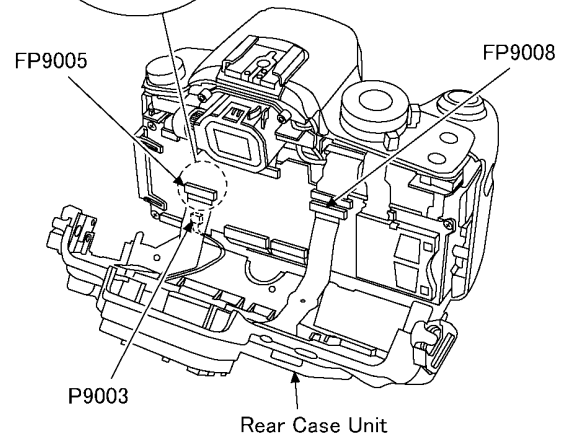
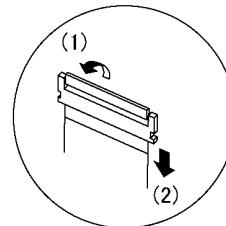
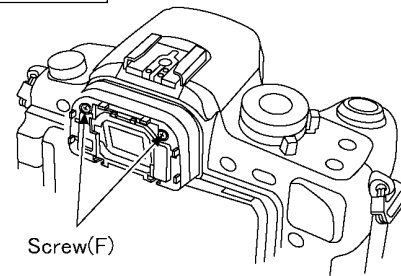
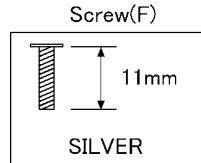
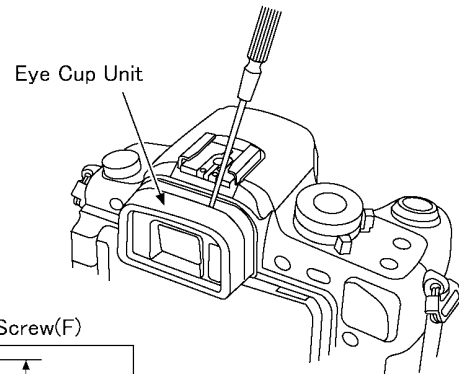

**NOTE: (When Replacing)**

When remove the flex, pull up the locking tab in the direction of arrow (1), and then remove the flex in the direction of arrow (2).

(Fig. D2)

### 9.3.2. Removal of the Top Case Unit

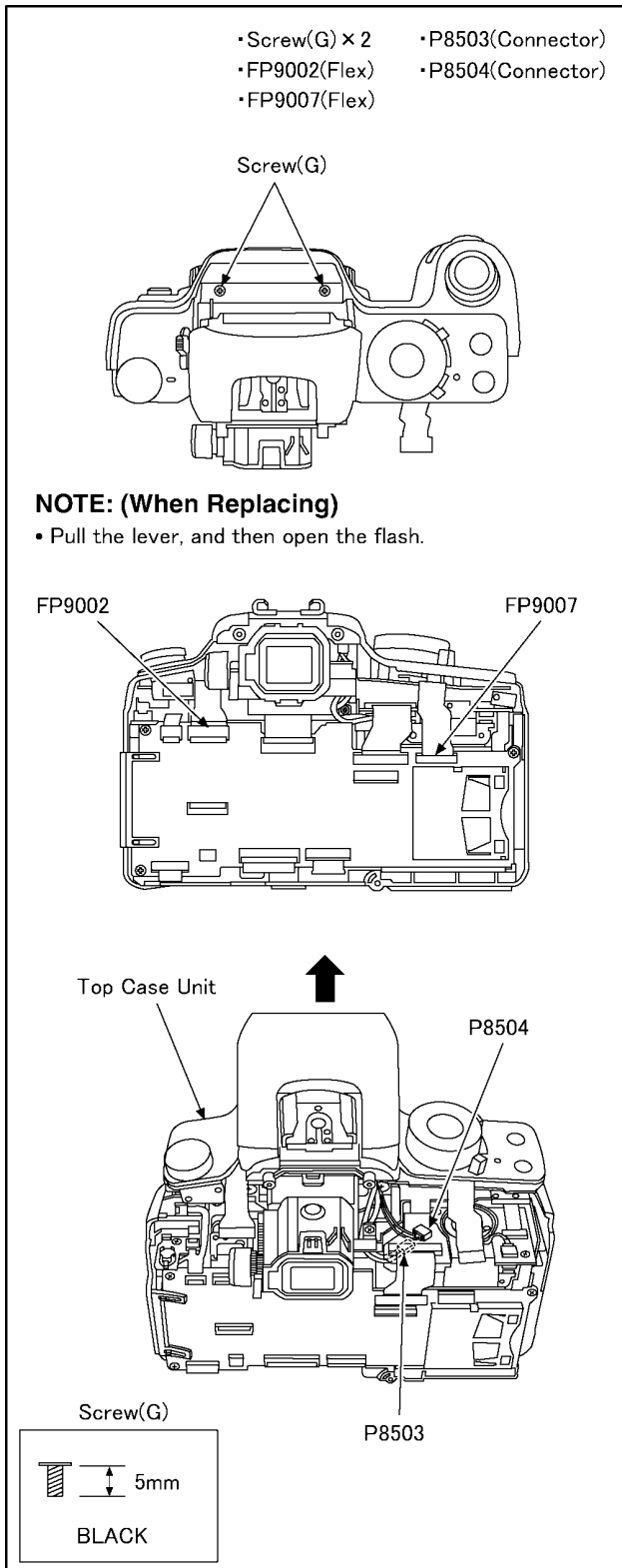

(Fig. D3)

### 9.3.3. Removal of the LVF Unit

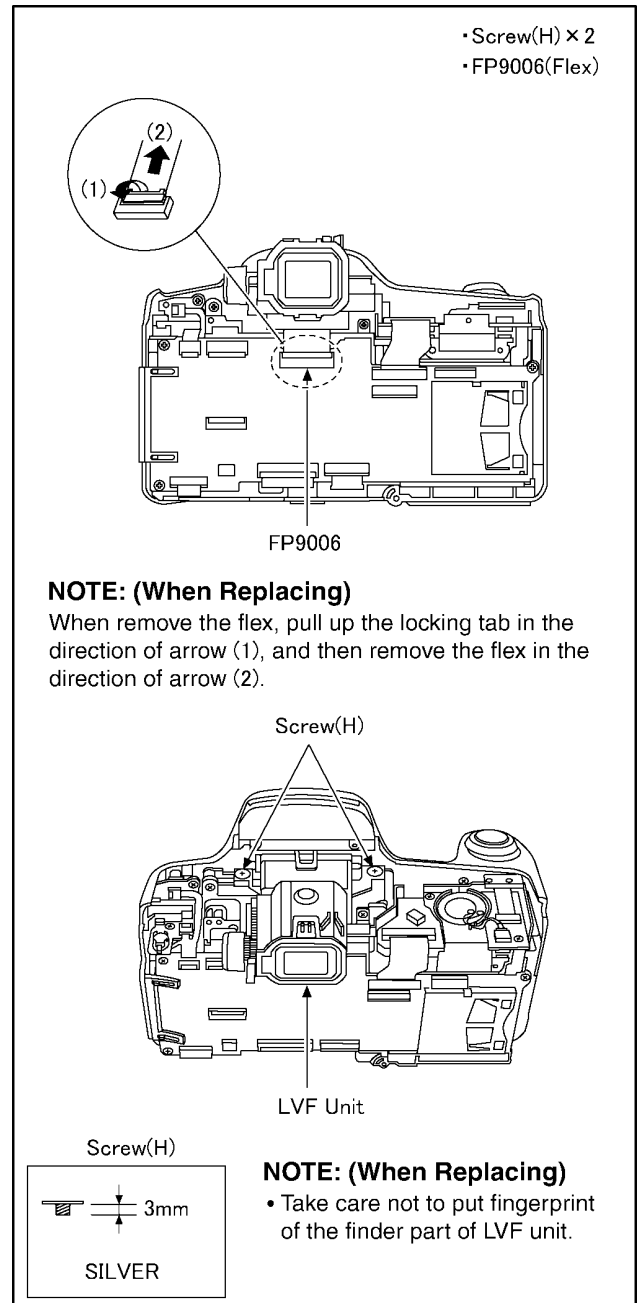

(Fig. D4)

### 9.3.4. Removal of the Main P.C.B.

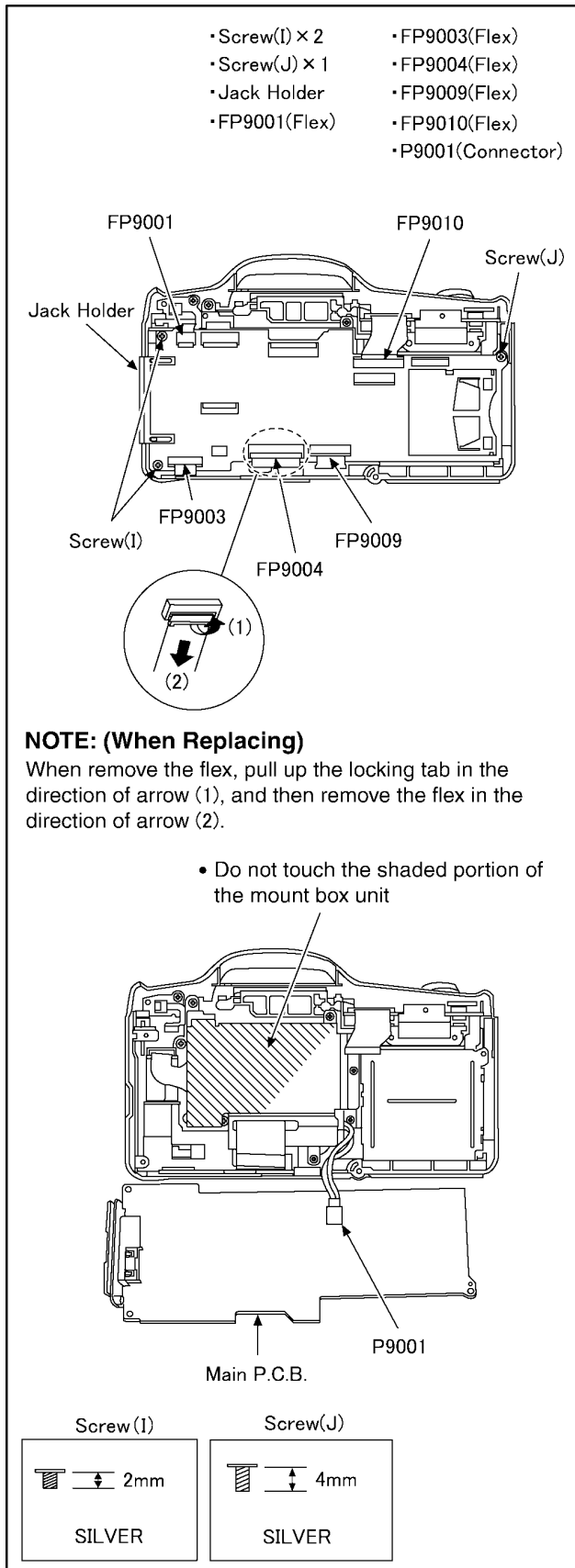

(Fig. D5)

### 9.3.5. Removal of the Front Case Unit

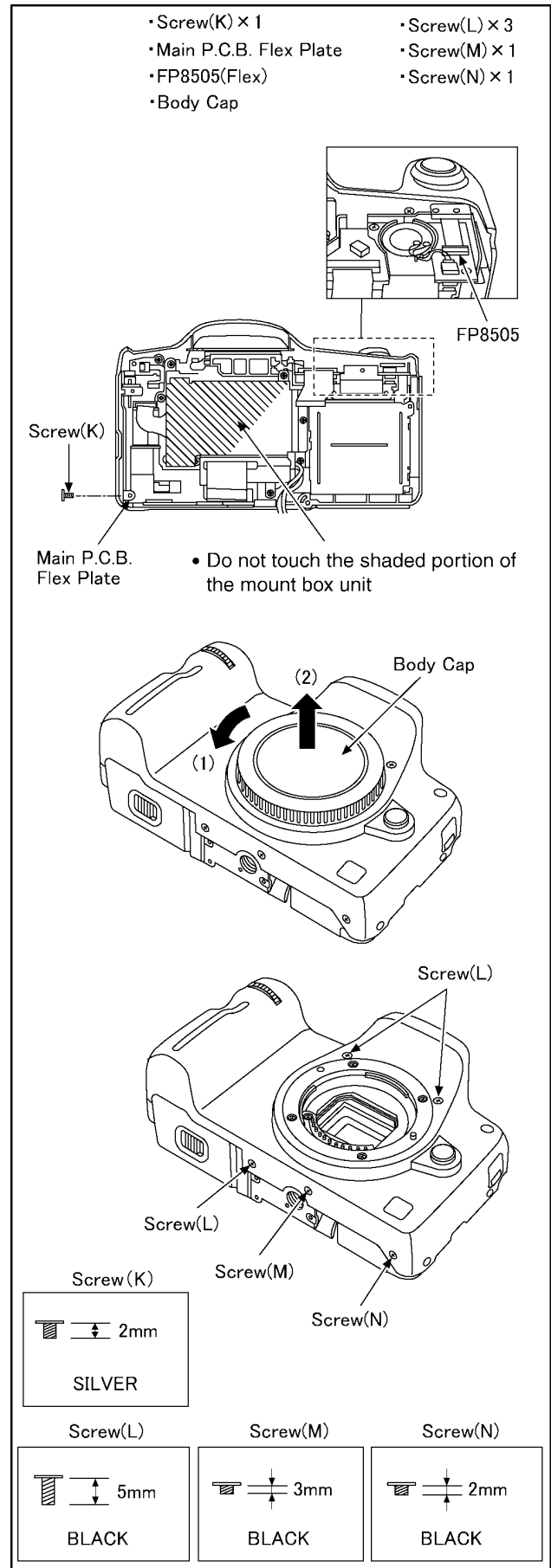

(Fig. D6)

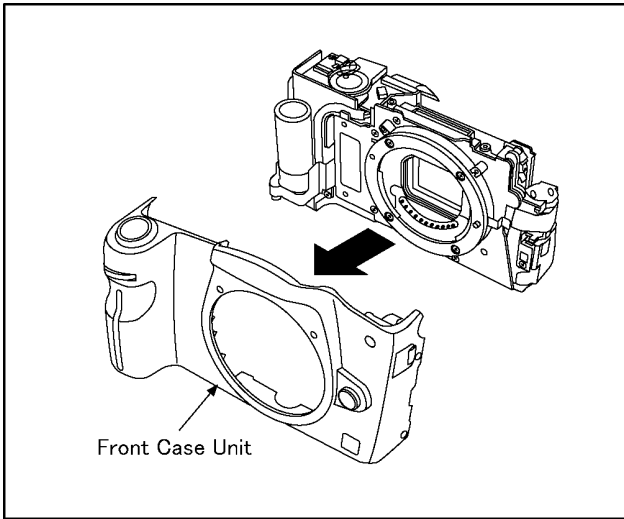

(Fig. D7)

### 9.3.6. Removal of the Battery Case Unit

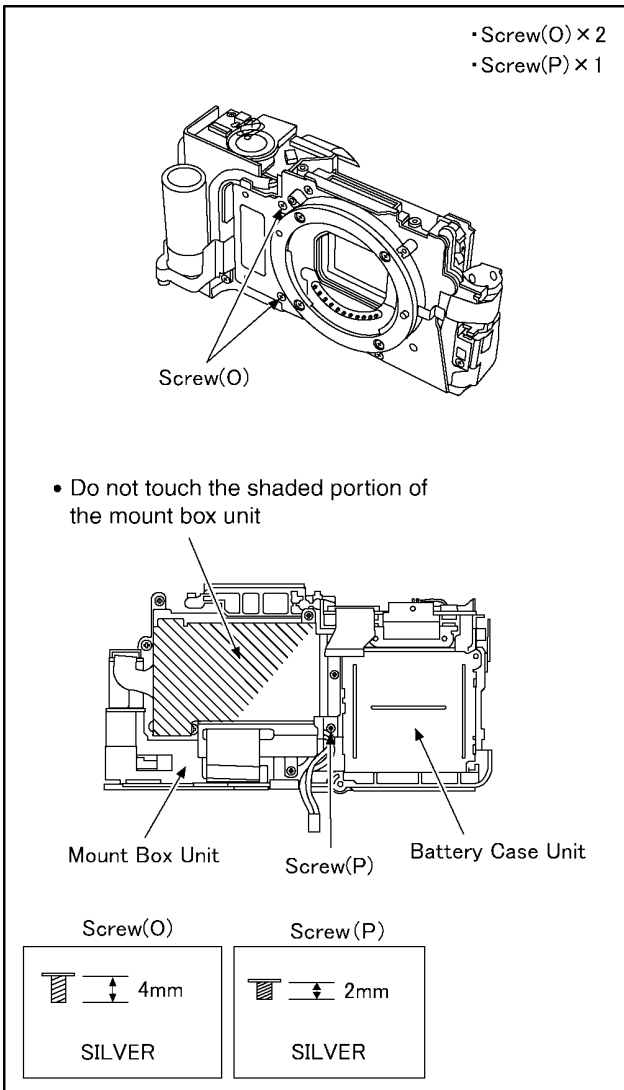

(Fig. D8)

### 9.3.7. Removal of the Flash P.C.B.

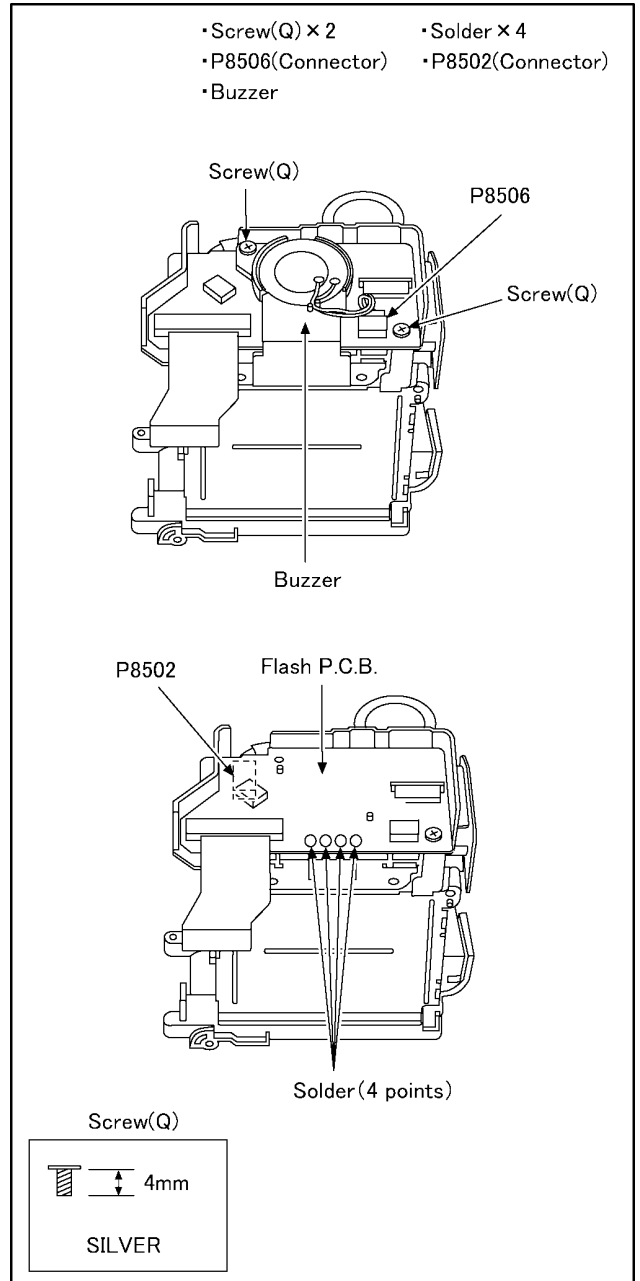

(Fig. D9)

### 9.3.8. Removal of the Flash Sub P.C.B. Unit

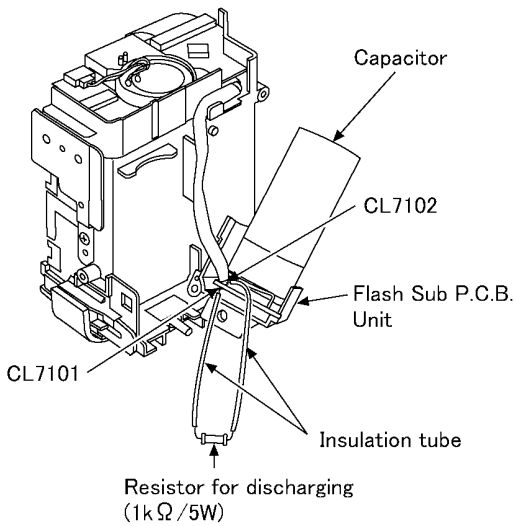
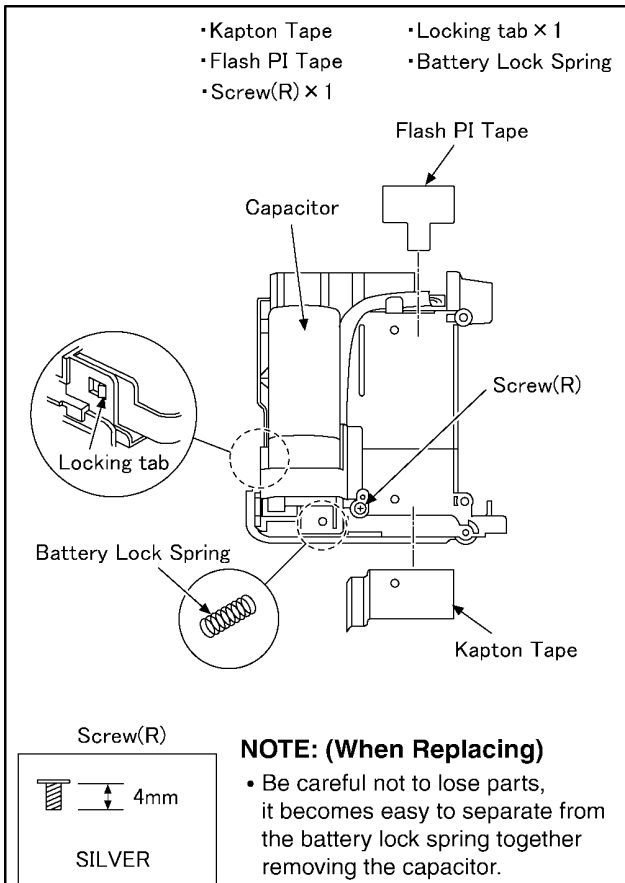

#### ⚠ CAUTION

**Be sure to discharge the capacitor on Flash Sub P.C.B. before disassembling.**

1. Remove the Flash Sub P.C.B. unit.
2. Put the insulation tube on the lead part of resistor (ERG5SJ102: 1kΩ/5W).
3. Put the resistor between both installation part of capacitor (CL7101-CL7102) for approx. 5 seconds.

(Fig. D10)

### 9.3.9. Removal of the AF Assist P.C.B., Remote P.C.B. and LP SW P.C.B.

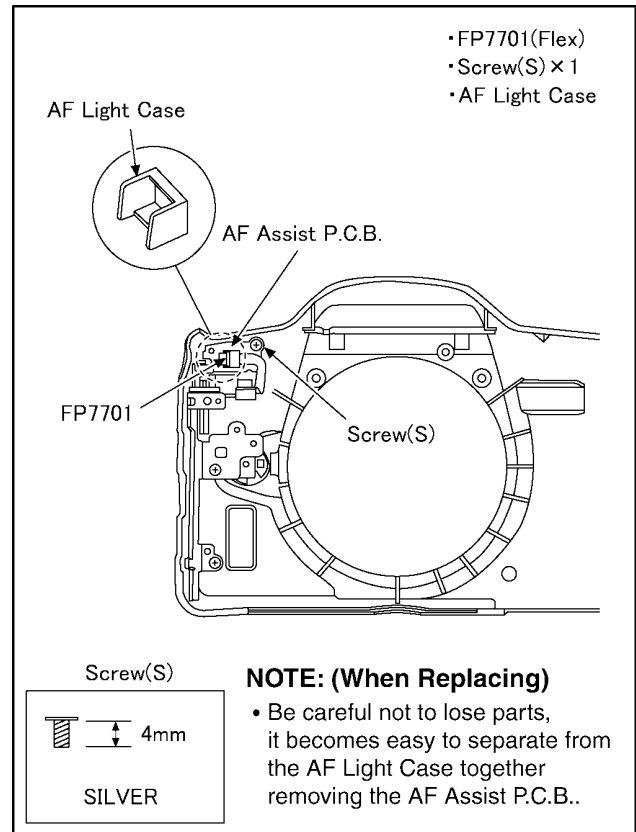

(Fig. D11)



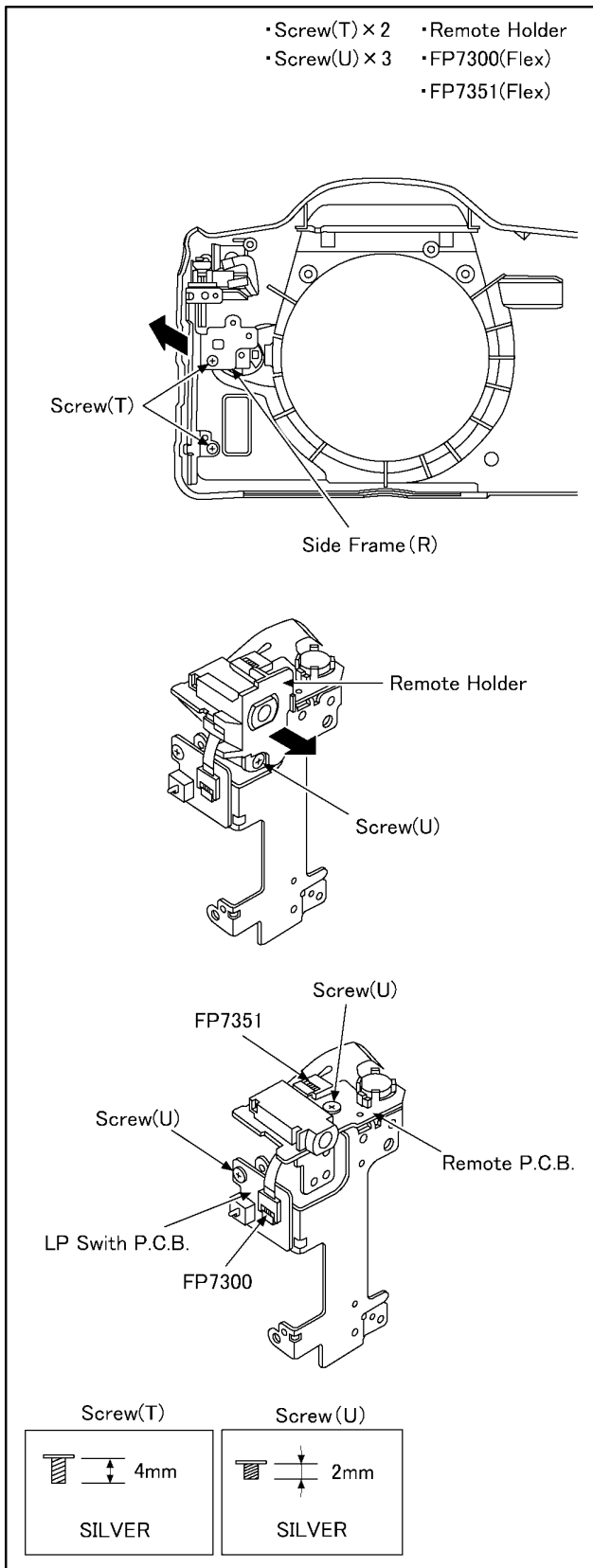

(Fig. D12)

### 9.3.10. Removal of the Optical Sensor Unit

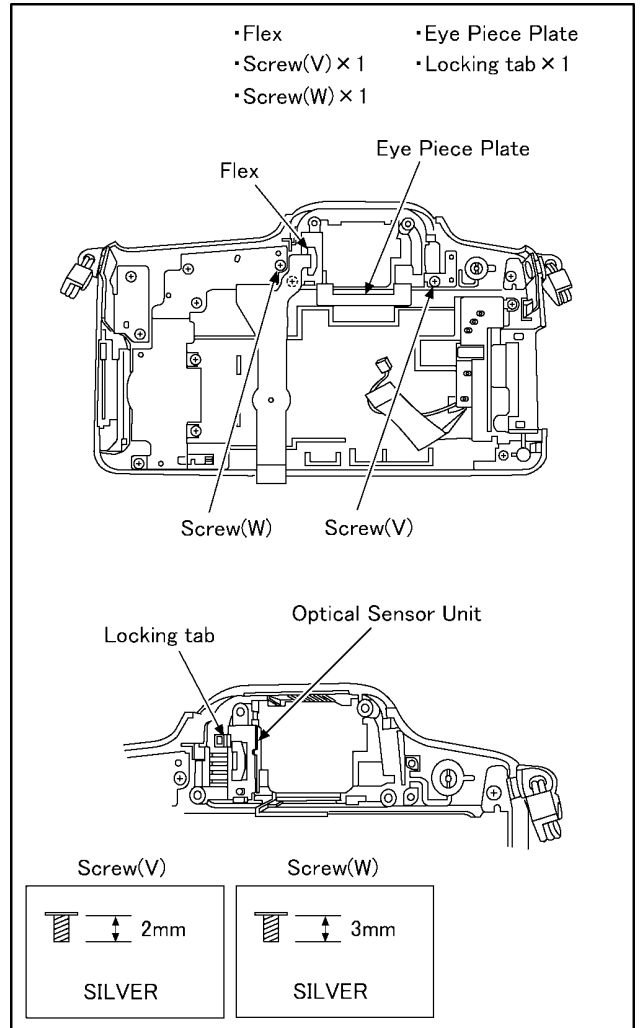

(Fig. D13)

### 9.3.11. Removal of the LCD Unit

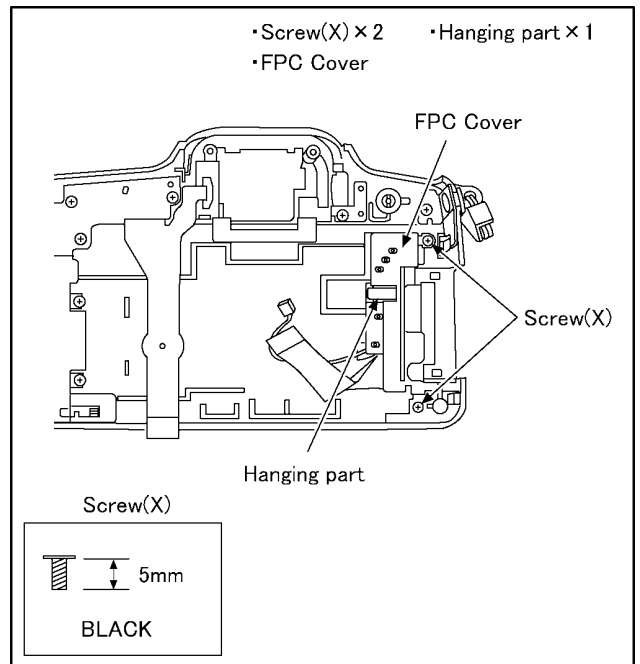

(Fig. D14)

### 9.3.12. Removal of the LCD TFT Unit

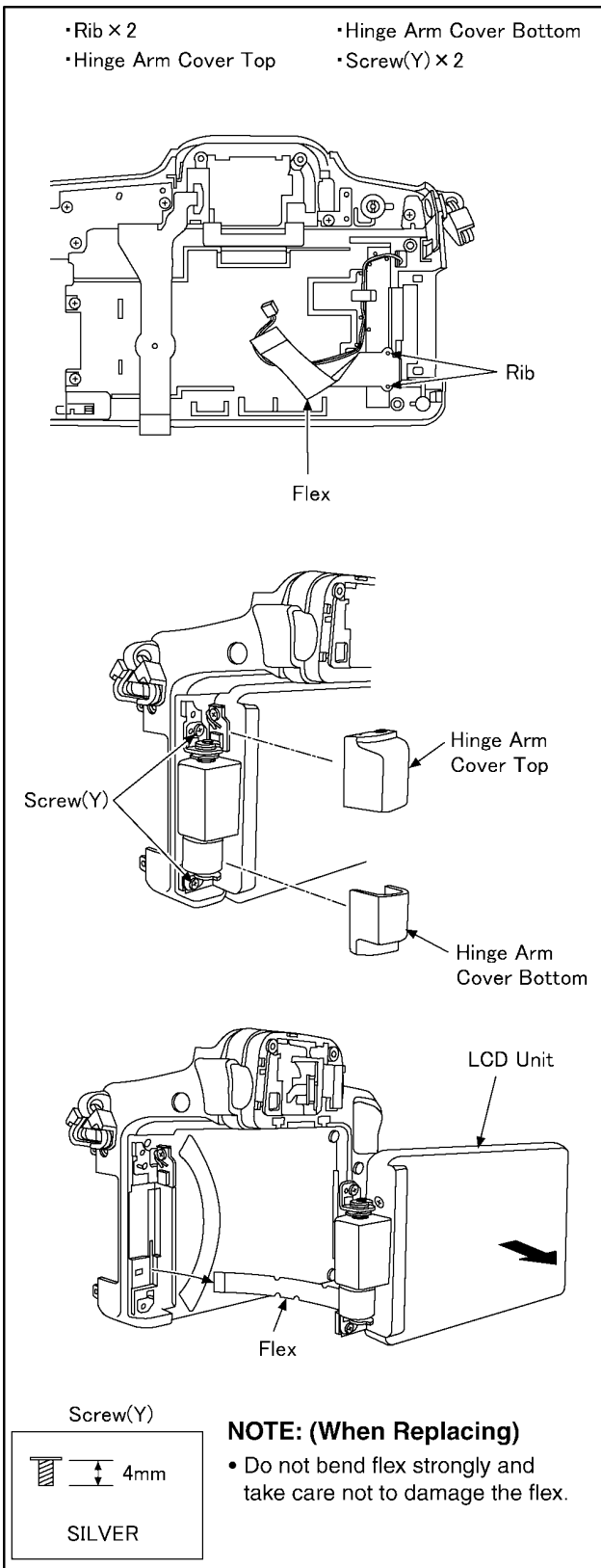

(Fig. D15)

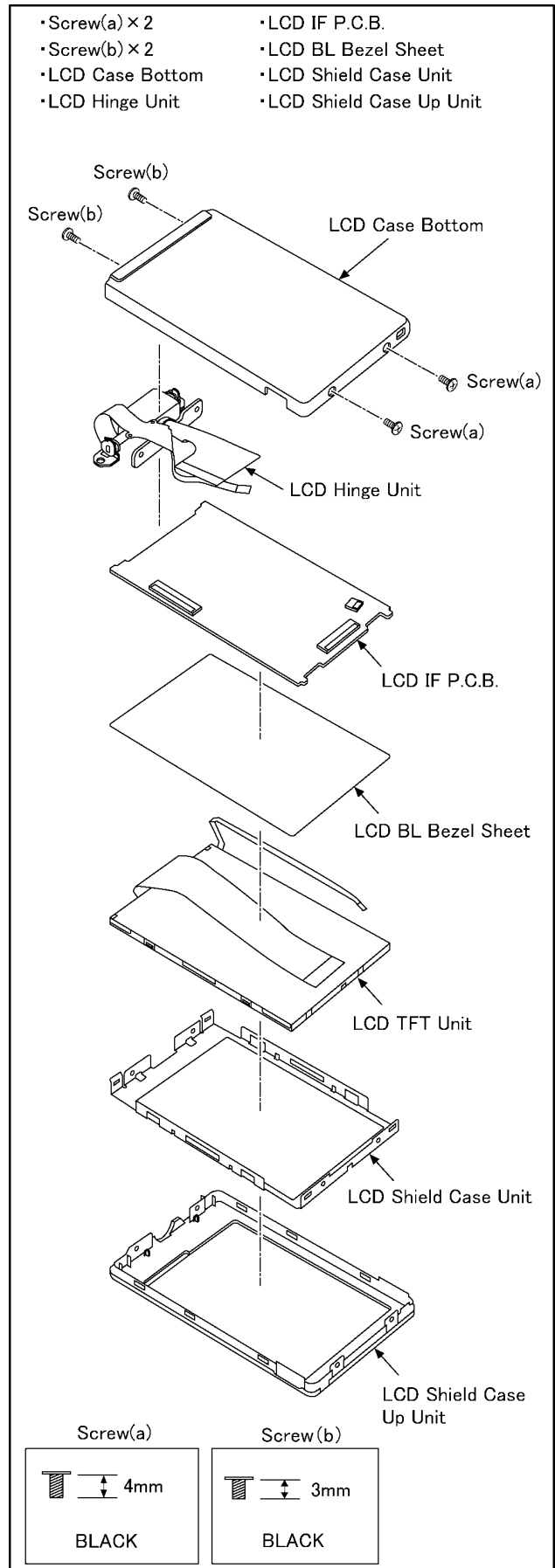

(Fig. D16)

## 9.4. Disassembly and Assemble Procedure for the Lens

Refer to the following table and the illustration for disassembly and assembly.

**NOTE:**

1. To keep maintaining the dustproof environment, it is recommended dealing with Clean box.  
(Refer to "8.2. Clean Box" which is found in section "8. Service Fixture & Tools" of this manual.)
2. Do not allow dirt and dust to get into the inside part/component of the unit.
3. Do not touch the surface of the lens glasses with your fingers.
4. Blow off the dust on the surface of the lens with a blower brush.
5. Use lens cleaning KIT (BK)(VFK1900BK).

### Interchangeable Lens (H-FS014045)

**CAUTION:**

Keep covering with Lens cap front, Lens cap rear, other than necessary cases.

Concerned parts		screws			Torque value
Part name	Ref. No.	Ref. No.	Color	Length(mm)	
Shading frame	202	B201	Black	3.0 mm	10±1.2 N·cm
		B202	Black	3.0 mm	10±1.2 N·cm
		B203	Black	3.0 mm	10±1.2 N·cm
L mount unit	206	B208	Silver	5.0 mm	20±1.2 N·cm
		B209	Silver	5.0 mm	20±1.2 N·cm
		B210	Silver	5.0 mm	20±1.2 N·cm
		B211	Silver	5.0 mm	20±1.2 N·cm
Mount contact unit	203	B213	Silver	3.0 mm	8±1.0 N·cm
Rear frame 2 unit	207	B204	Black	4.0 mm	10±1.2 N·cm
		B205	Black	4.0 mm	10±1.2 N·cm
		B206	Black	4.0 mm	10±1.2 N·cm
		B207	Black	4.0 mm	10±1.2 N·cm

**NOTE:**

1. When installing the screws, be sure to use the torque driver (RFKZ0456) and tighten the screws with specified torque, mentioned on the above table.
2. The Ref.B212 is no need to remove/install for disassembly and assembly.  
If necessary, use VFK1390 (small driver) when screwing it.

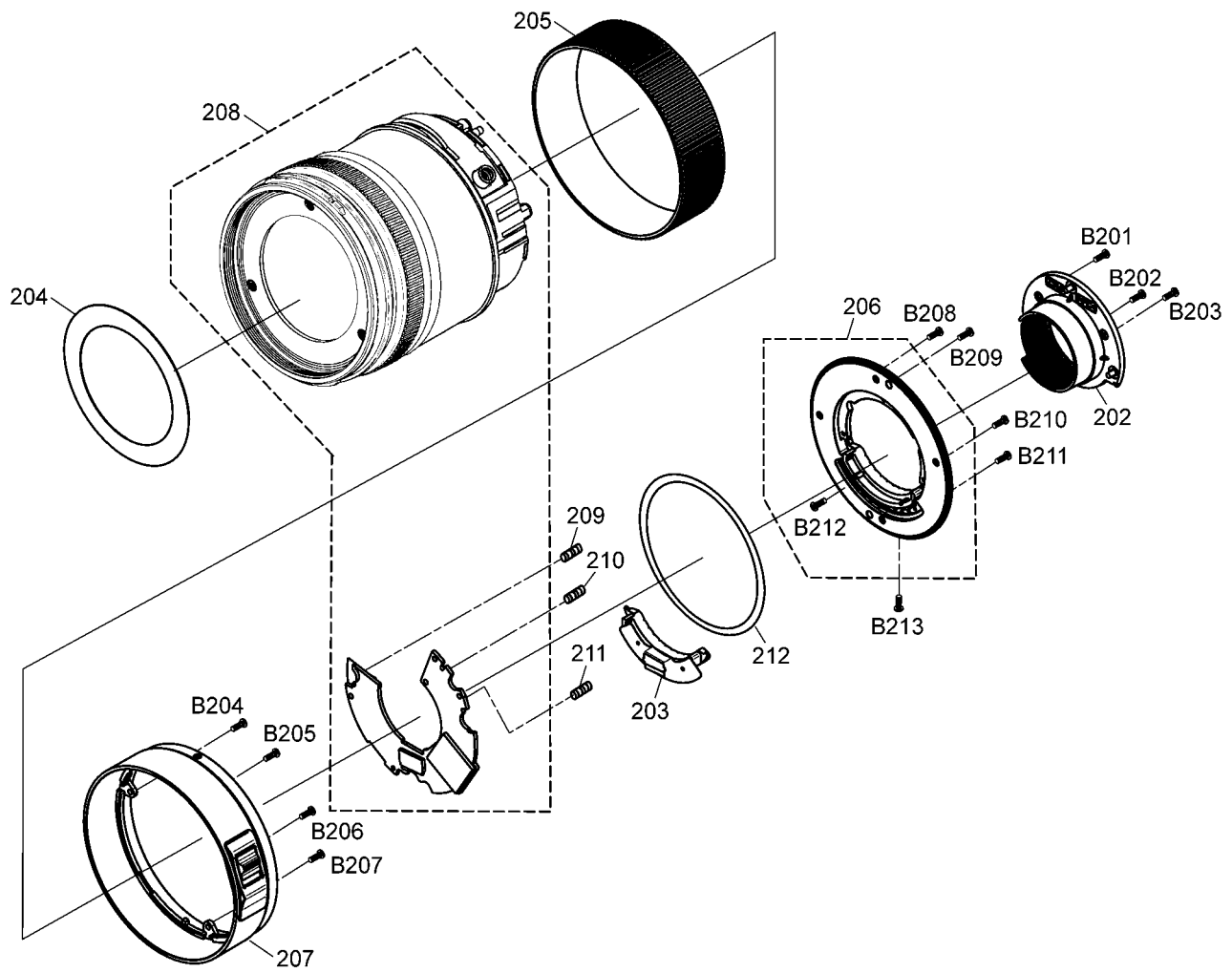

### 9.4.1. Removal of the Decoration Ring

**NOTE:**

Be careful not touch the lens surface with Tweezers when removing the Decoration Ring.

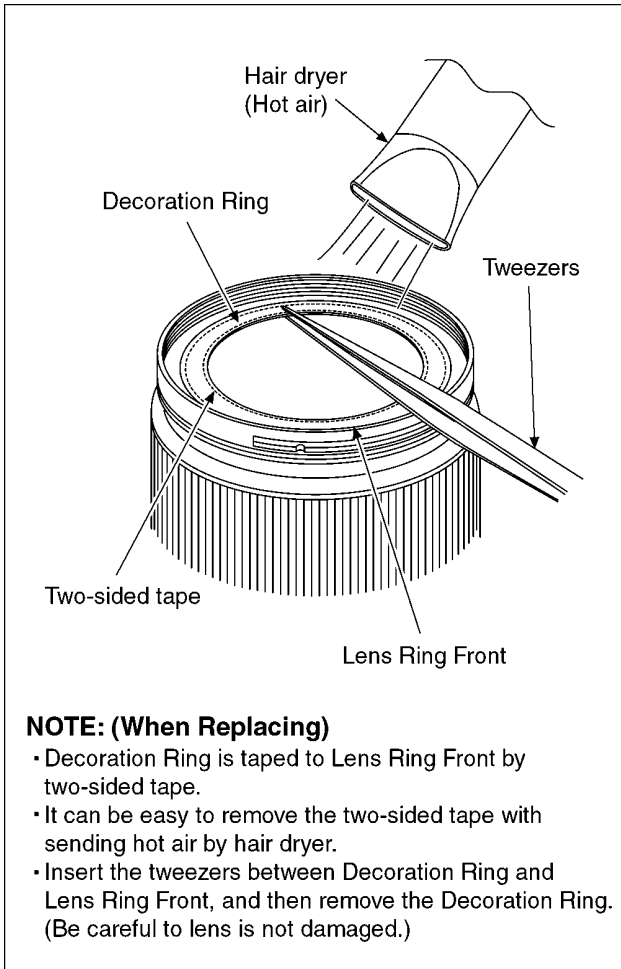

### 9.4.2. Phase alignment of the Decoration Ring

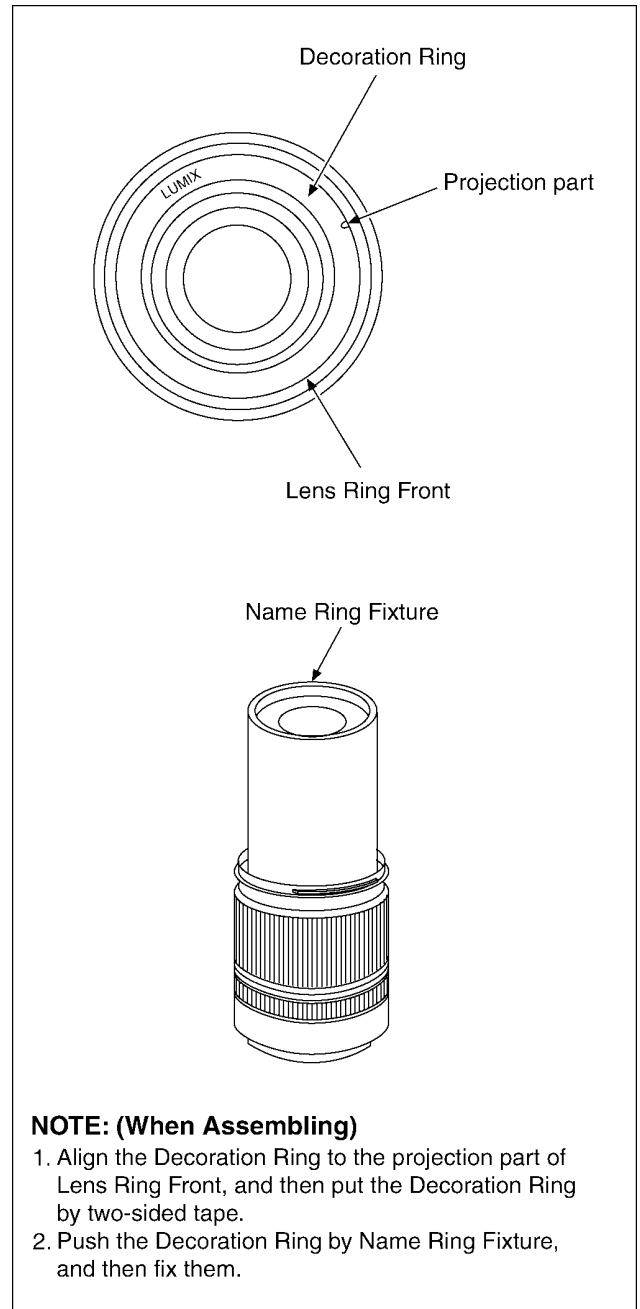

# 10 Measurements and Adjustments

## 10.1. Matrix Chart for Replaced Part and Necessary Adjustment

The relation between Replaced part and Necessary Adjustment is shown in the following table.

When concerned part is replaced, be sure to achieve the necessary adjustment(s).

As for Adjustment condition/procedure, consult the "Adjustment Manual" which is available in Adjustment software.

The Adjustment software is available at "TSN Website", therefore, access to "TSN Website" at "Support Information from NWBG/VDBG-AVC".

**NOTE:**

After adjustments have been terminated, make sure to achieve "INITIAL SETTINGS".

Adjustment Item		Replaced Part					
		Mount Box (*3)	Main P.C.B. (*2)	Eye sensor	Flash P.C.B.	LCD/LVF U	Lens U/L-Mount/Rear Frame
Camera Body Section	ISO sensitivity adjustment (ISO)	○	○	—	—	—	—
	High brightness coloration (SEN)	○	○	—	—	—	—
	AWB adjustment (WBM/WBH)	○	○	—	—	—	—
	IMAGE SENSOR white scratch compensation (WKI)	○	○	—	—	—	—
	IMAGE SENSOR black scratch compensation (BKI)	○	○	—	—	—	—
	EYE SENSOR adjustment (EYE)	—	○	○	—	—	—
	Mount Box Adjustment data writing	○	—	—	—	—	—
Lens With Body	Resolution inspection (*1)	○	—	—	—	—	○

**NOTE: (\*1)**

It is carried out, not only replacing the part(s)/component, but also to support customer requirement to check total performance of the DMC-G1K in case of any mishandling, dropping or others.

**NOTE: (\*2)**

Before replacing the MAIN PCB, proceed the EEPROM data backup from the unit.

After replacing the MAIN PCB, overwrite the EEPROM data with backup data from the unit before proceeding the adjustment / inspection.

**NOTE: (\*3)**

After replacing the MOUNT BOX BLOCK, the mount box data has to be stored to the unit, before proceeding the adjustment / inspection.

For more details, consult the adjustment instruction which is available together with the Maintenance software at "software download" on the "Support Information from NWBG/VDBG-AVC" web-site in "TSN system".

\*.There is no LCD / LVF adjustment in this model.

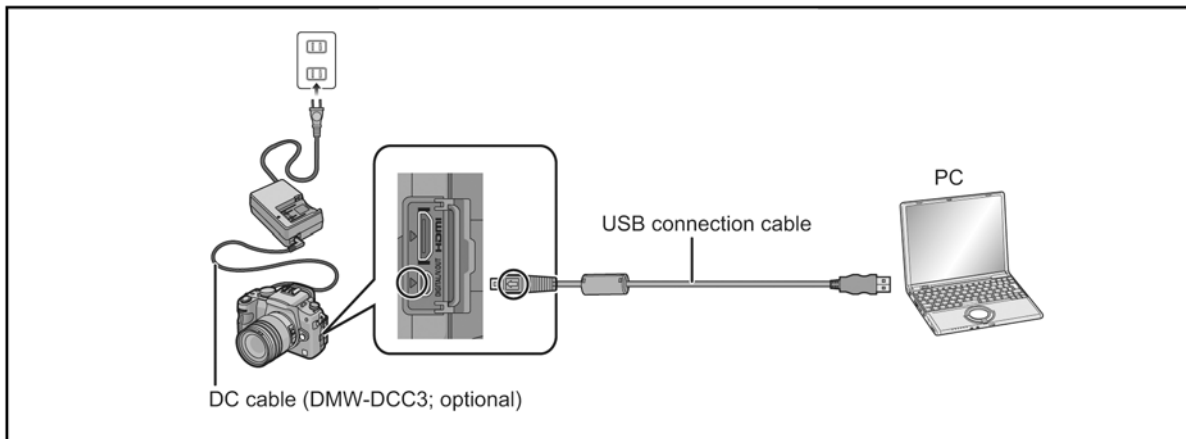

# 11 Maintenance

## 1.ABOUT THE LENS:

### DUST/DIRT ON THE OUTER CASING PART(S)

1. Blow off the dust first, then sweep out the dust from narrower spaces with soft cleaning brush.
2. Wipe up the Outer casing part with the dry fuzz-free cloth.

### DUST/DIRT ON THE LENS GLASSES

Define the location of the dust/dirt first, whether it is outside lens surface or not.

#### [1].When it is outside surface of the lens:

1. When the dust and/or dirt gets on the outer side surface of the Lens glasses, order the following procedures.
  - (1). Blow off the dust on the lens glass surface with the Blower, gently. (Do not Blow too strongly.)
  - (2). Wipe out the dirt on the lens glass surface with Lens cleaning KIT (VFK1900BK) if necessary. (Consult the Instruction sheet which is included in the Lens cleaning KIT in details.)

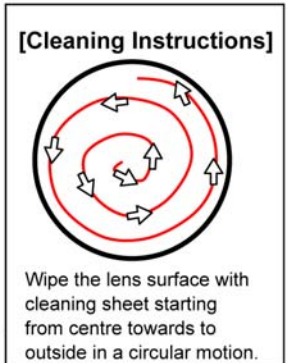

#### [2].When it is inside of the lens:

1. It is not allowed to disassemble the Lens other than described in service manual. In case of the dust/dirt is inside of the "LENS MAIN BLOCK UNIT", contact to the service department of sales

## 2.ABOUT THE BODY:

NOTE:

- +Before cleaning the camera, remove the battery and/or disconnect power plug from the outlet. Also, remove the SD Memory card and lens unit.

### DUST/DIRT ON THE OUTER CASING PART (S)

1. Blow off the dust first, then sweep out the dust from narrower spaces with soft cleaning brush.
2. Wipe up fingerprint and/or dirt on the Outer casing part with the dry fuzz-free cloth.

### DUST/DIRT ON THE IMAGE SENSOR

[PROCEDURES]

1. Blow off the dust on the surface of the Image sensor with the Blower. (Refer to the following Figure.)
  - +Keep the Mount Facing down condition towards to floor when cleaning.
  - +Do not put the Blower further inside than the lens mount.
  - +Be careful not to blow too strongly.
2. Wipe off the dirt on the image sensor surface with Lens cleaning KIT(VFK1900BK).

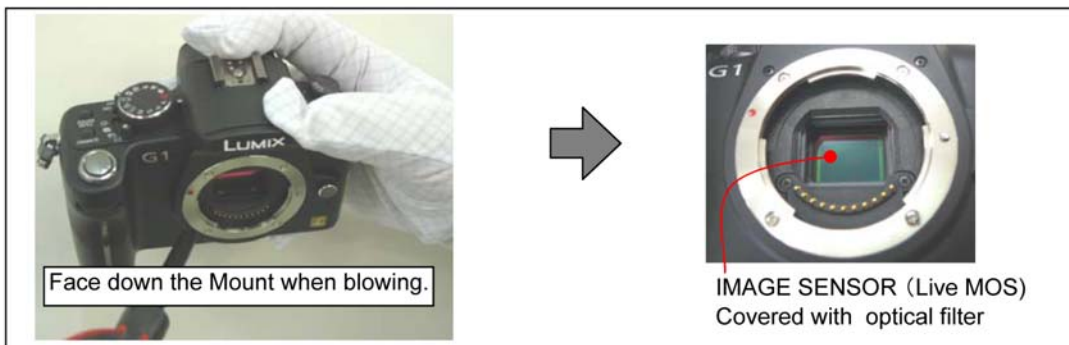

### 3.ABOUT THE LVF UNIT:

[PROCEDURES]

- 1.By referring the Disassembly & Assembly procedures and remove the LVF unit.
- 2.Disassemble the LVF unit as follows, then blow off the dust with blower.
3. Wipe off the dirt on the surface of glasses with Lens cleaning KIT(VFK1900BK), if necessary.

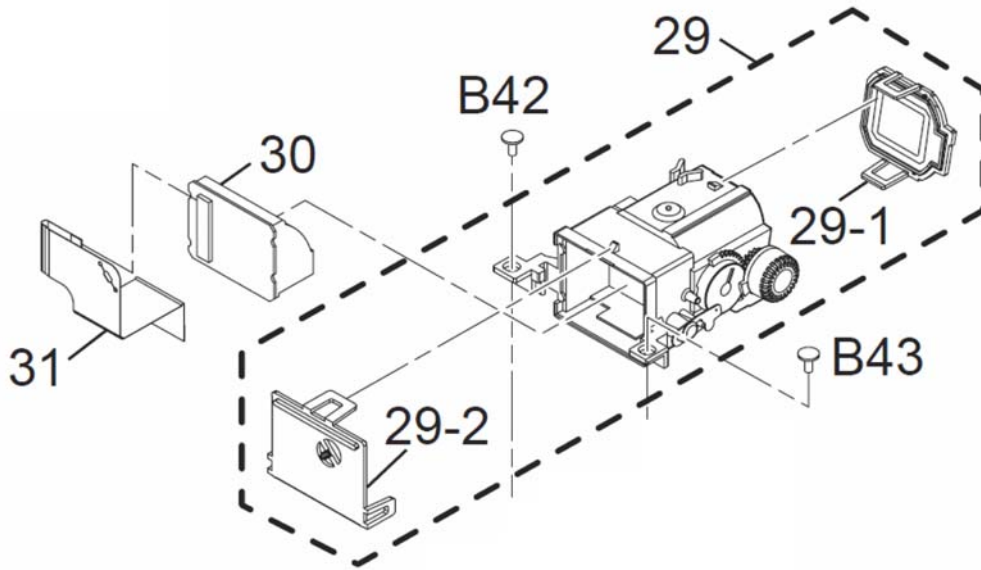



# Service Manual

---

## Diagrams and Replacement Parts List

### Digital Camera

Model No.

DMC-G1KPP	DMC-G1KGGH
DMC-G1KEB	DMC-G1KGGK
DMC-G1KEC	DMC-G1KGGN
DMC-G1KEG	DMC-G1KGGT
DMC-G1KGC	DMC-G1KGGJ
DMC-G1KGD	

Vol. 1  
 Colour  
 (A).....Blue Type  
 (R).....Red Type

### Table of contents

S1. About Indication of The Schematic Diagram.....	S-1	S5.3. LP SW P.C.B. ....	S-10
S1.1. Important Safety Notice.....	S-1	S5.4. Remote P.C.B.....	S-11
S2. Voltage Chart .....	S-2	S5.5. LCD IF P.C.B.....	S-12
S2.1. Flash P.C.B. ....	S-2	S5.5.1. LCD IF P.C.B. (Component Side).....	S-12
S3. Block Diagram.....	S-3	S5.5.2. LCD IF P.C.B. (Foil Side) .....	S-13
S3.1. Overall Block Diagram .....	S-3	S5.6. Hinge SW P.C.B.....	S-14
S4. Schematic Diagram.....	S-4	S5.7. Flash Sub P.C.B.....	S-14
S4.1. Interconnection Diagram .....	S-4	S6. Replacement Parts List.....	S-15
S4.2. Flash Schematic Diagram .....	S-5	S7. Exploded View .....	S-21
S4.3. AF Assist Schematic Diagram .....	S-6	S7.1. Frame and Casing Section.....	S-21
S4.4. LP SW Schematic Diagram.....	S-6	S7.2. Camera Lens Section.....	S-22
S4.5. Remote Schematic Diagram .....	S-7	S7.3. Packing Parts and Accessories Section.....	S-23
S4.6. LCD IF Schematic Diagram .....	S-7		
S4.7. Hinge SW Schematic Diagram.....	S-8		
S4.8. Flash Sub Schematic Diagram.....	S-8		
S5. Print Circuit Board .....	S-9		
S5.1. Flash P.C.B. ....	S-9		
S5.2. AF Assist P.C.B. ....	S-10		

## S1. About Indication of The Schematic Diagram

### S1.1. Important Safety Notice

COMPONENTS IDENTIFIED WITH THE MARK  $\triangle$  HAVE THE SPECIAL CHARACTERISTICS FOR SAFETY. WHEN REPLACING ANY OF THESE COMPONENTS USE ONLY THE SAME TYPE.

1. Although reference number of the parts is indicated on the P.C.B. drawing and/or schematic diagrams, it is NOT mounted on the P.C.B. when it is displayed with "\$" mark.
2. It is only the "Test Round" and no terminal (Pin) is available on the P.C.B. when the TP (Test Point) indicated as "●" mark.
3. The voltage being indicated on the schematic diagram is measured in "Standard-Playback" mode when there is no specify mode is mentioned.
4. Although the voltage and waveform available on here is measured with standard frame, it may be differ from actual measurement due to modification of circuit and so on.
5. The voltage being indicated here may be include observational-error (deviation) due to internal-resistance and/or reactance of equipment. Therefore, handle the value indicated on here as reference.
6. Use the parts number indicated on the Replacement Parts List .
7. Indication on Schematic diagrams:

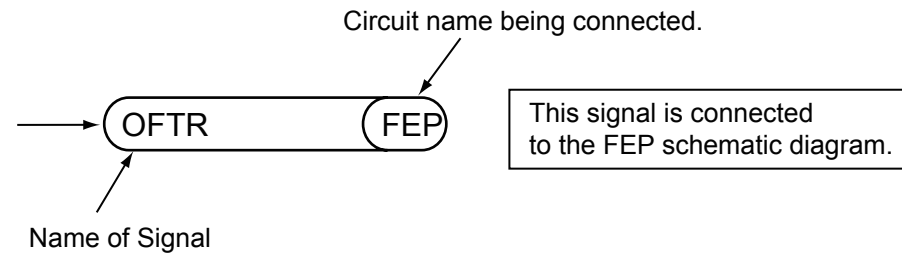

## S2. Voltage Chart

Note) Indicated voltage values are the standard values for the unit measured by the DC electronic circuit tester (high-impedance) with the chassis taken as standard.  
Therefore, there may exist some errors in the voltage values, depending on the internal impedance of the DC circuit tester.

### S2.1. Flash P.C.B.

REF No.	PIN No.	POWER ON
Q8501	1	0
Q8501	2	0
Q8501	3	0
Q8501	4	0
Q8501	5	3.3
Q8501	6	3.3
Q8501	7	3.3
Q8501	8	3.3
Q8502	1	10.1
Q8502	2	10.1
Q8502	3	0
Q8502	4	0
Q8502	5	10.1
Q8502	6	10.1
QR8501	1	0
QR8501	2	5.6
QR8501	3	0
QR8501	4	6.2
QR8501	5	5.6
QR8501	6	0
QR8502	E	0
QR8502	C	5.6
QR8502	B	0
QR8503	E	0
QR8503	C	0
QR8503	B	4.8
QR8504	E	0
QR8504	C	4.8
QR8504	B	0

# S3. Block Diagram

## S3.1. Overall Block Diagram

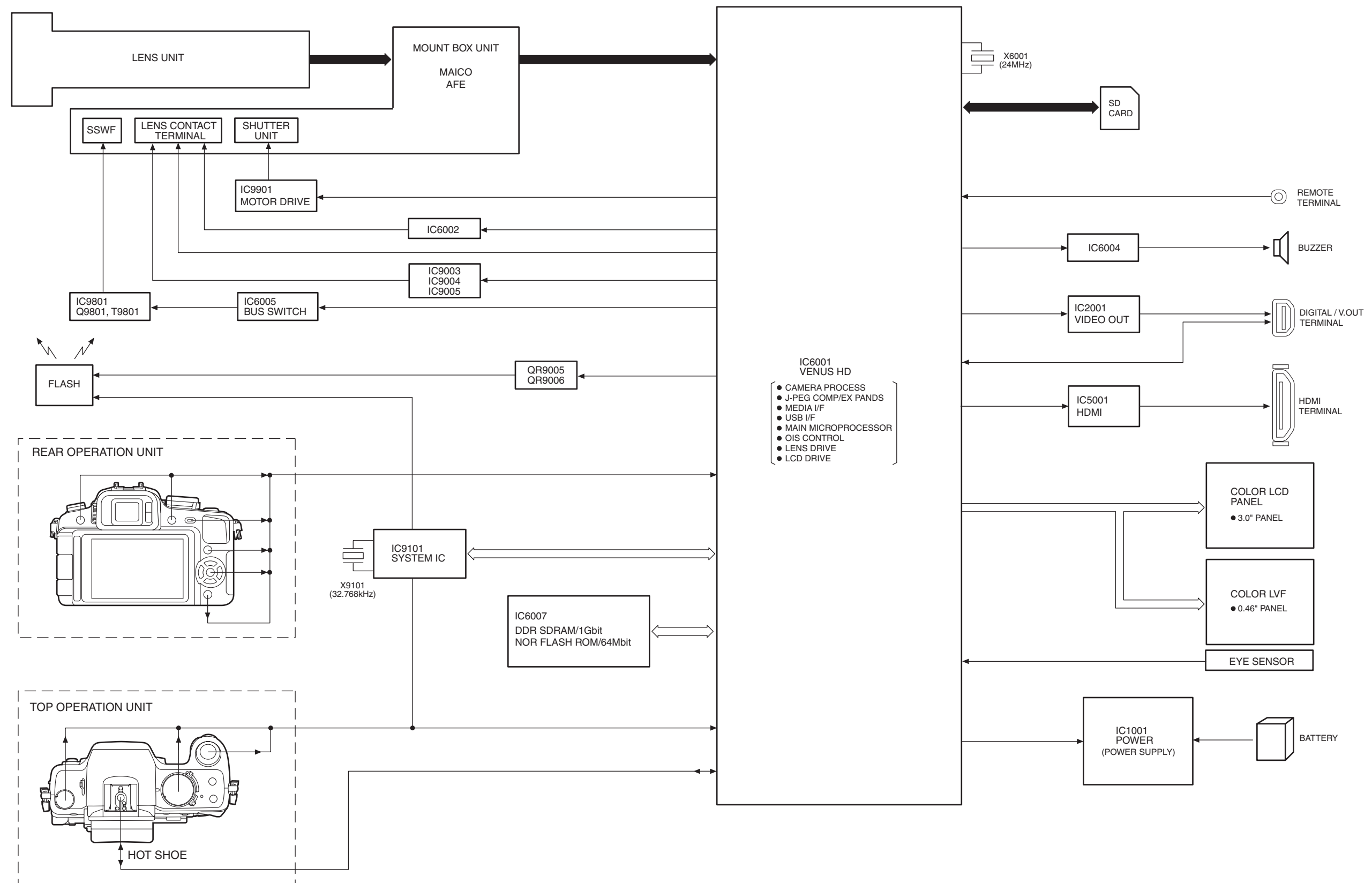



# S4.2. Flash Schematic Diagram

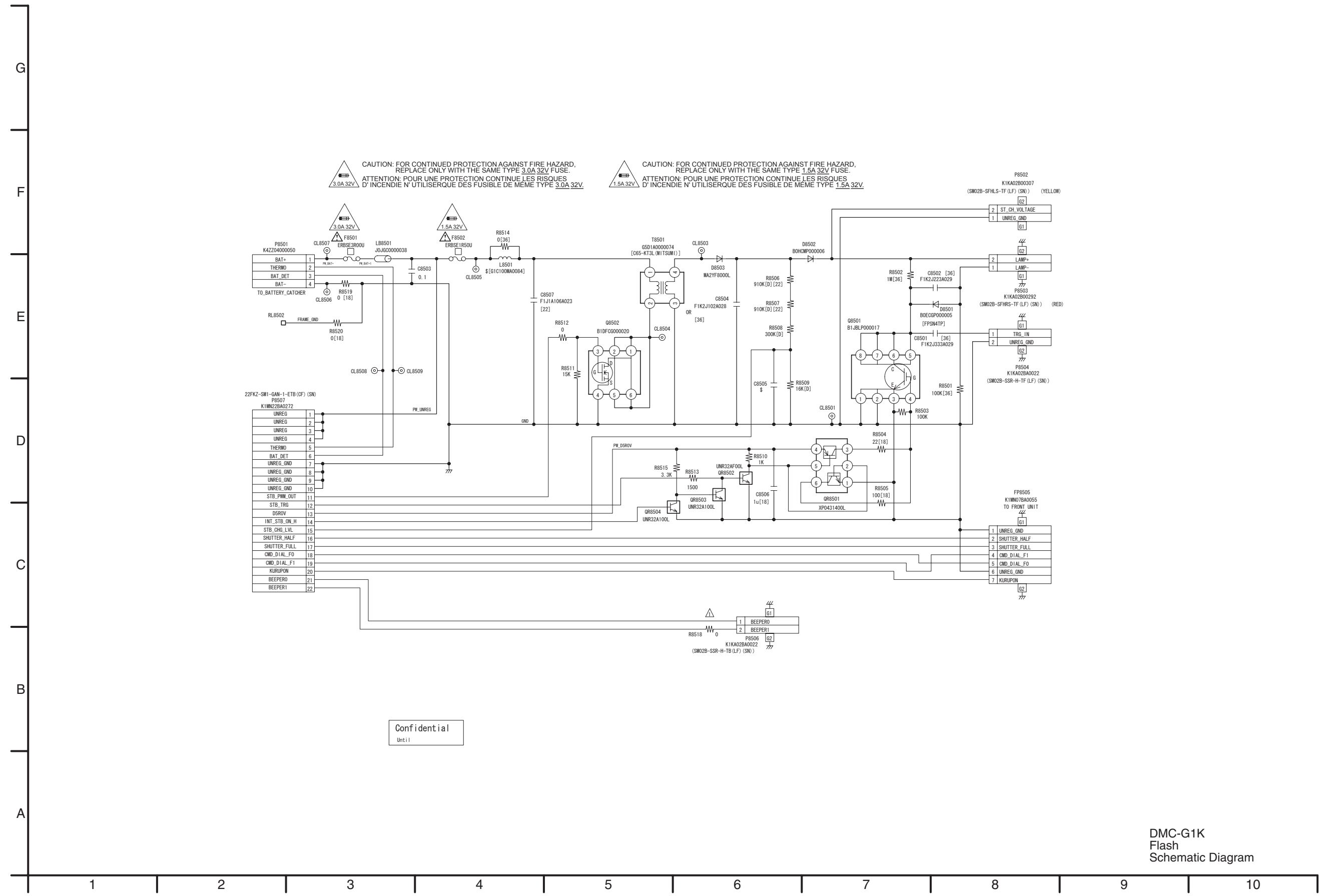

S4.3. AF Assist Schematic Diagram / S4.4. LP SW Schematic Diagram

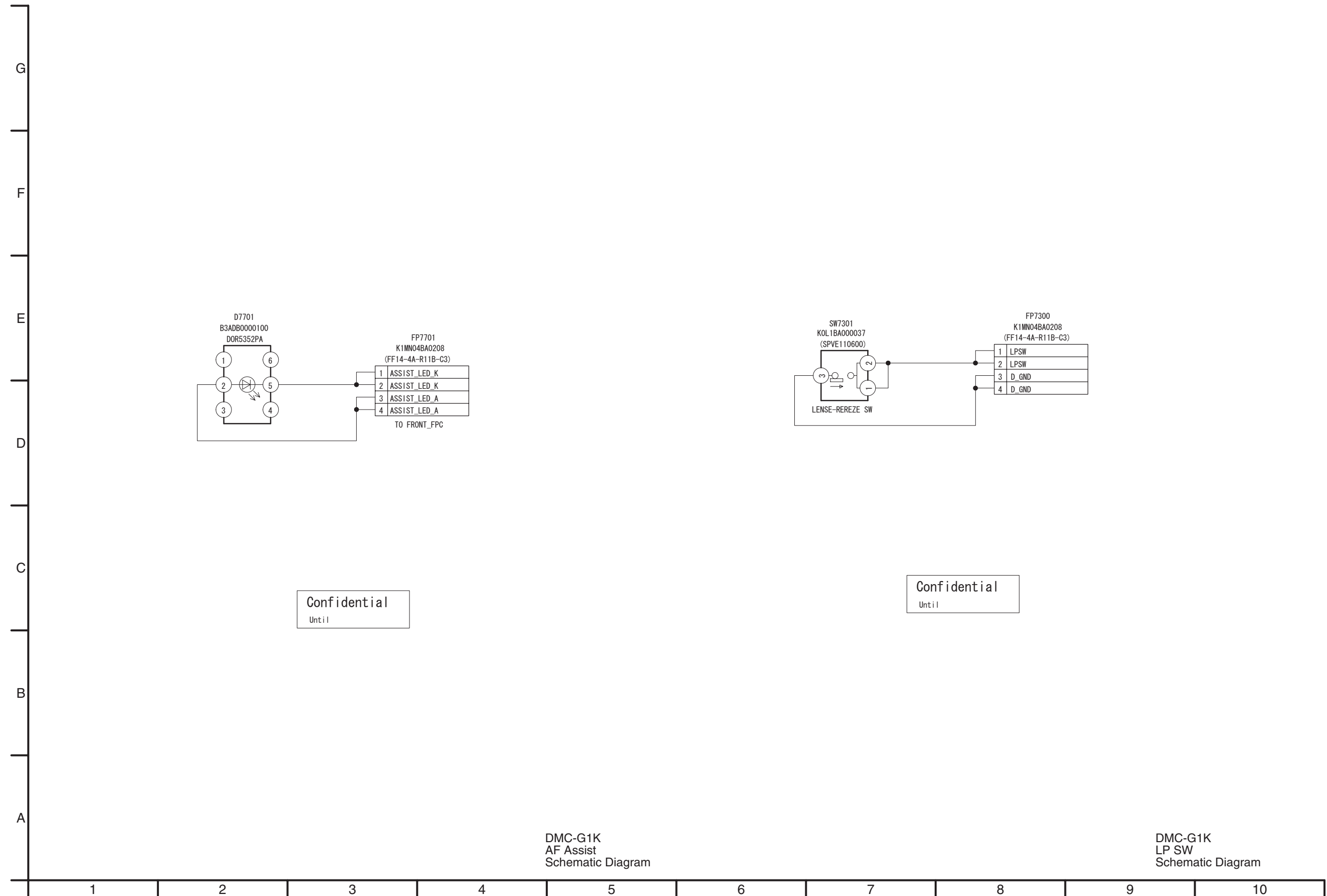

DMC-G1K  
AF Assist  
Schematic Diagram

DMC-G1K  
LP SW  
Schematic Diagram

S4.5. Remote Schematic Diagram / S4.6. LCD IF Schematic Diagram

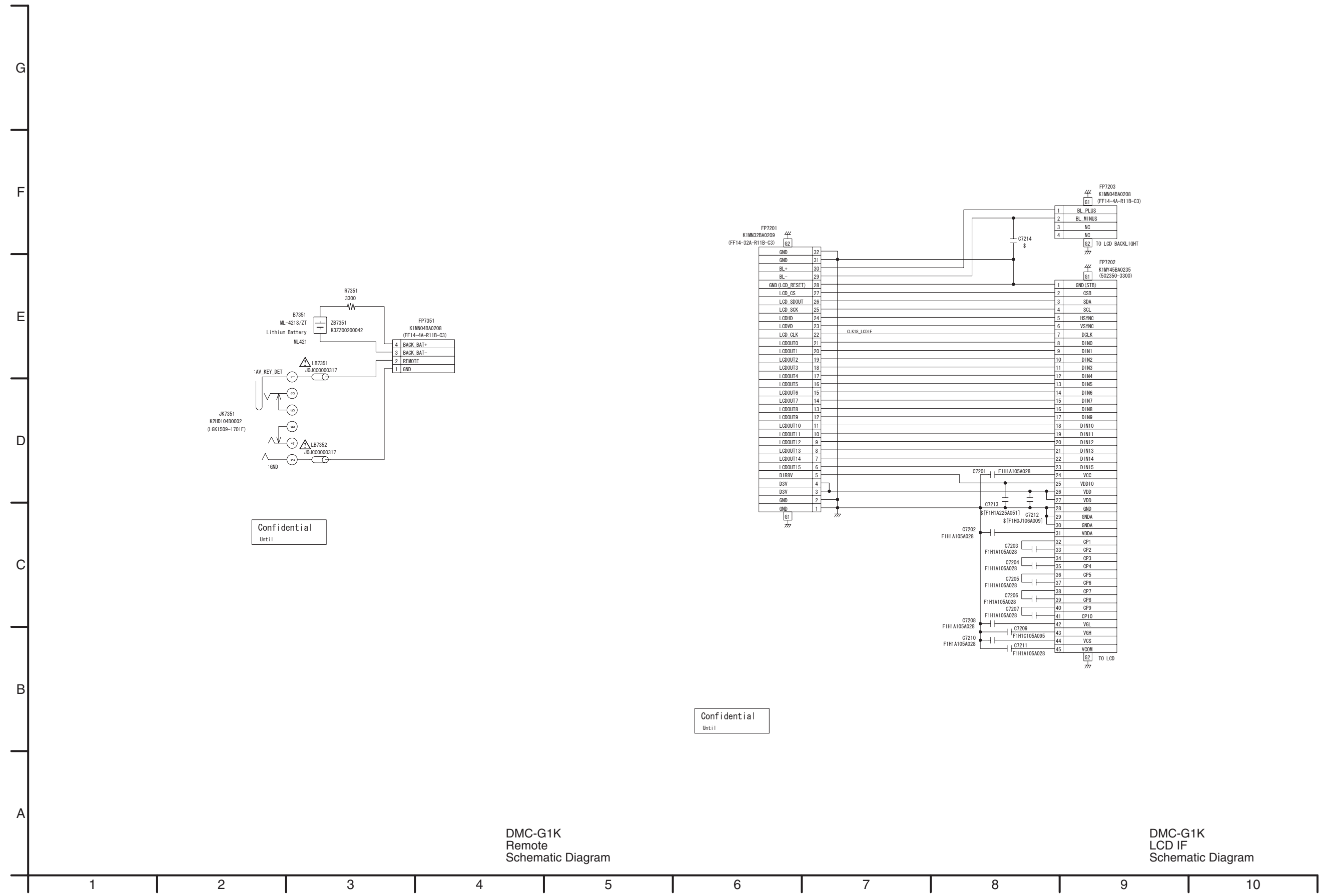

Confidential  
Until

Confidential  
Until

DMC-G1K  
Remote  
Schematic Diagram

DMC-G1K  
LCD IF  
Schematic Diagram

S4.7. Hinge SW Schematic Diagram / S4.8. Flash Sub Schematic Diagram

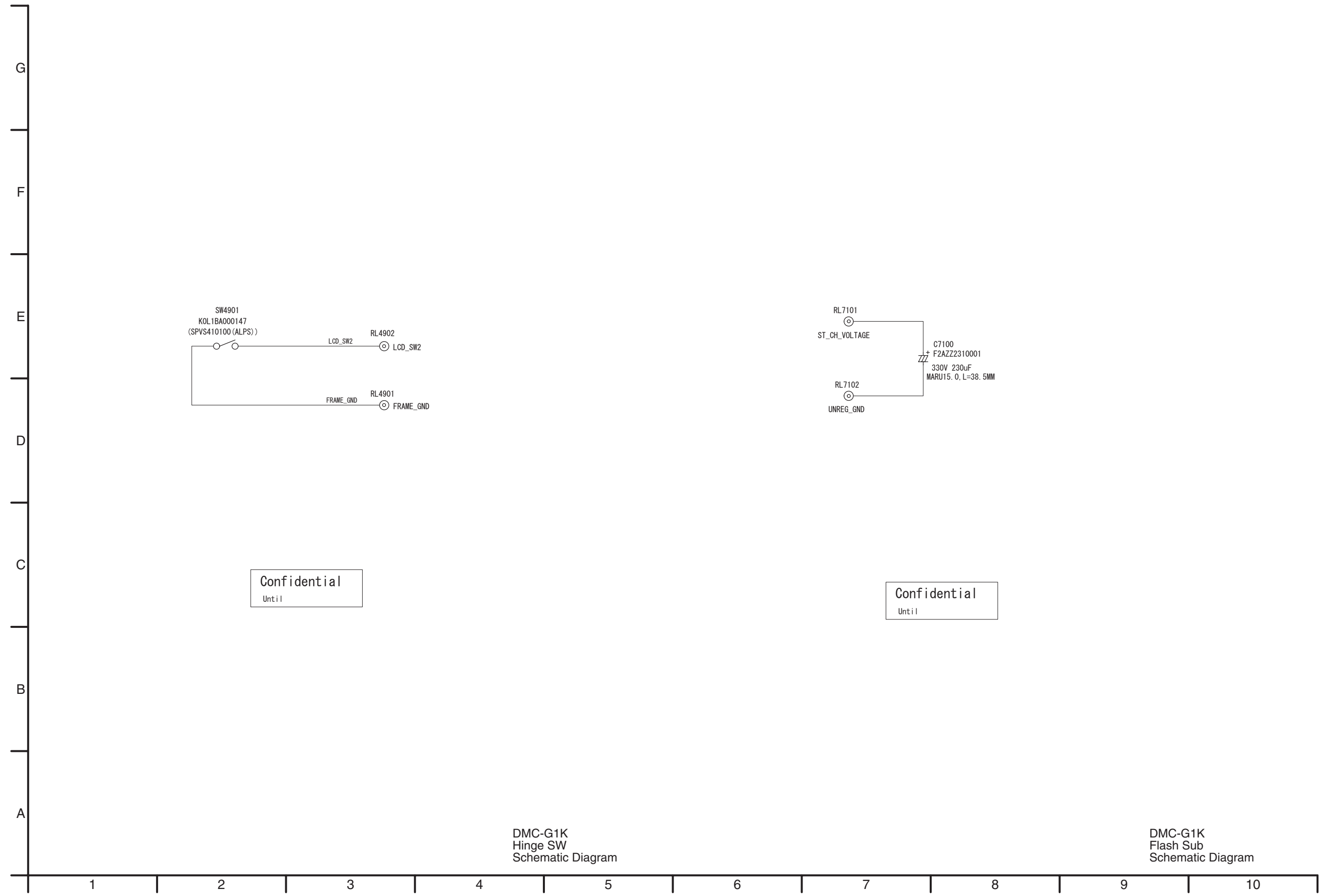

DMC-G1K  
Hinge SW  
Schematic Diagram

DMC-G1K  
Flash Sub  
Schematic Diagram



# S5. Print Circuit Board

## S5.1. Flash P.C.B.

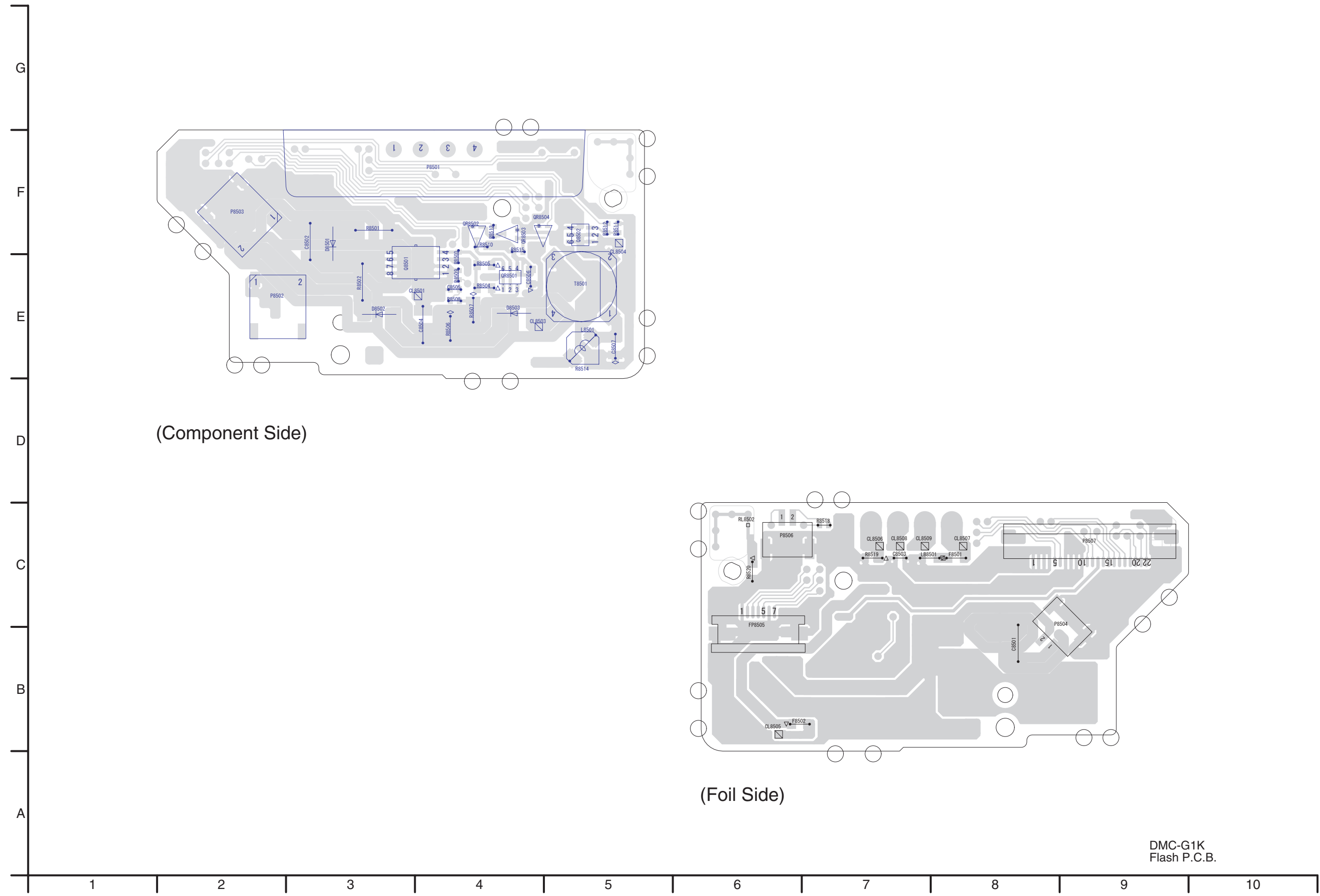

DMC-G1K  
Flash P.C.B.

S5.2. AF Assist P.C.B. / S5.3. LP SW P.C.B.

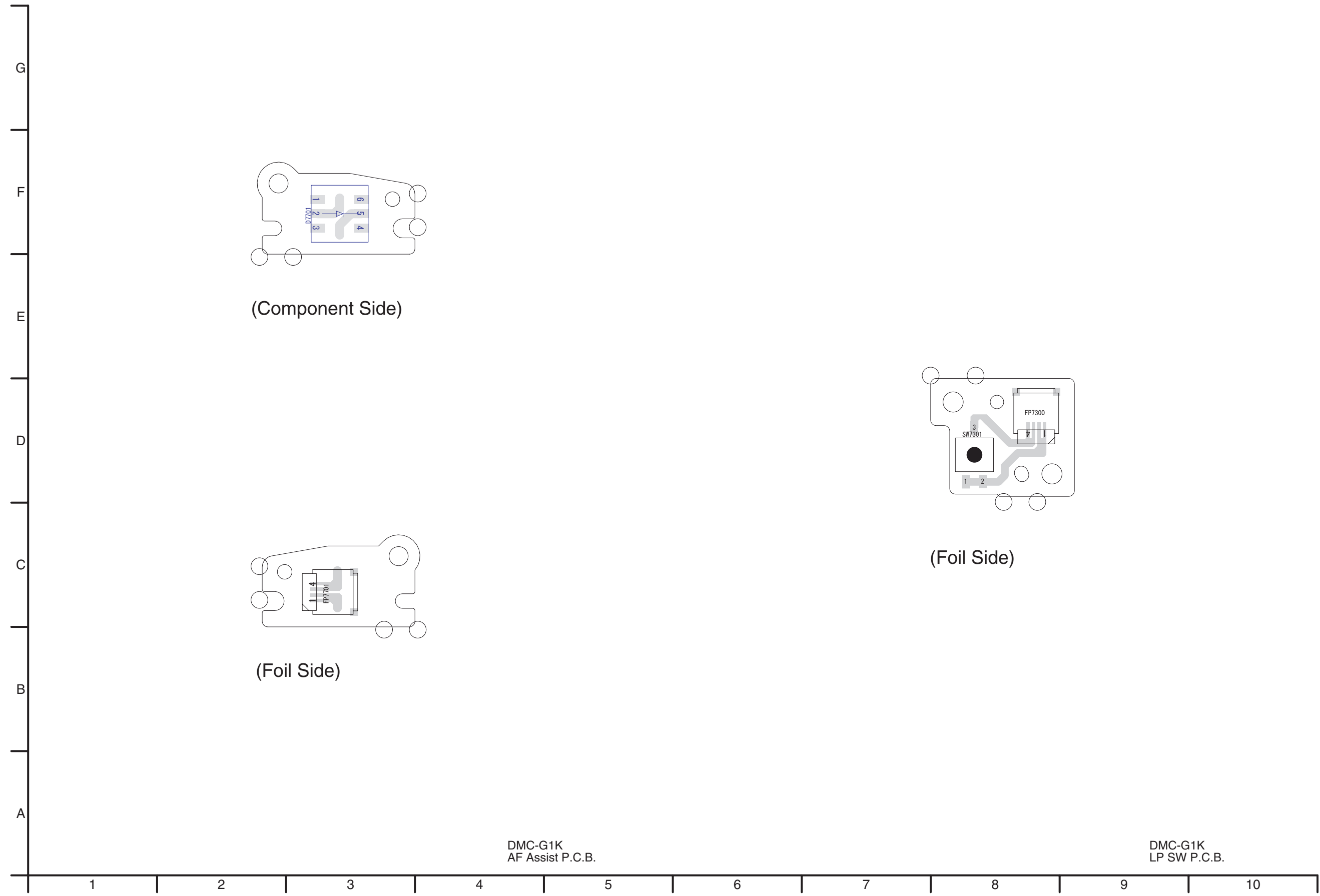

DMC-G1K  
AF Assist P.C.B.

DMC-G1K  
LP SW P.C.B.

S5.4. Remote P.C.B.

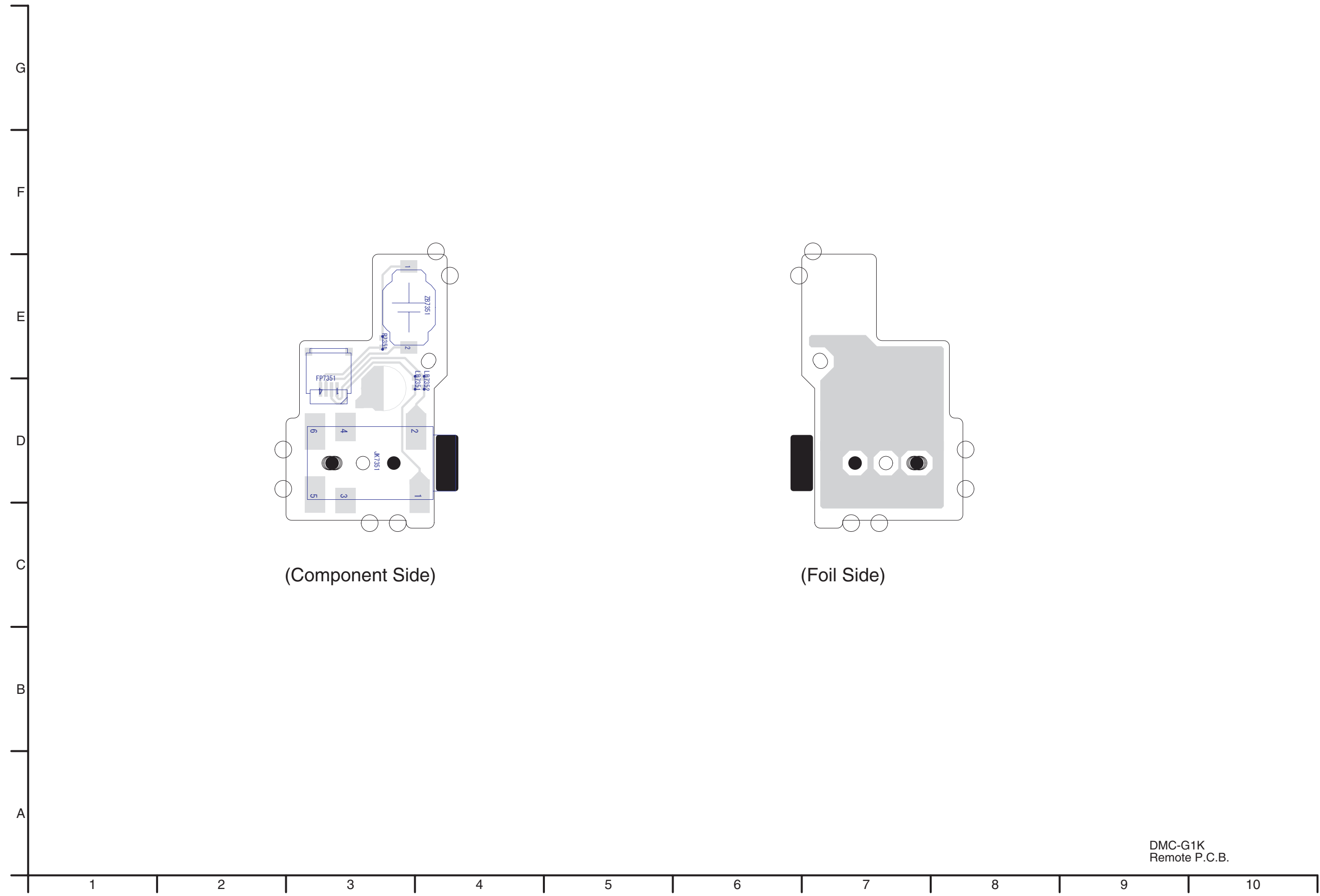

DMC-G1K  
Remote P.C.B.

**S5.5. LCD IF P.C.B.**

**S5.5.1. LCD IF P.C.B. (Component Side)**

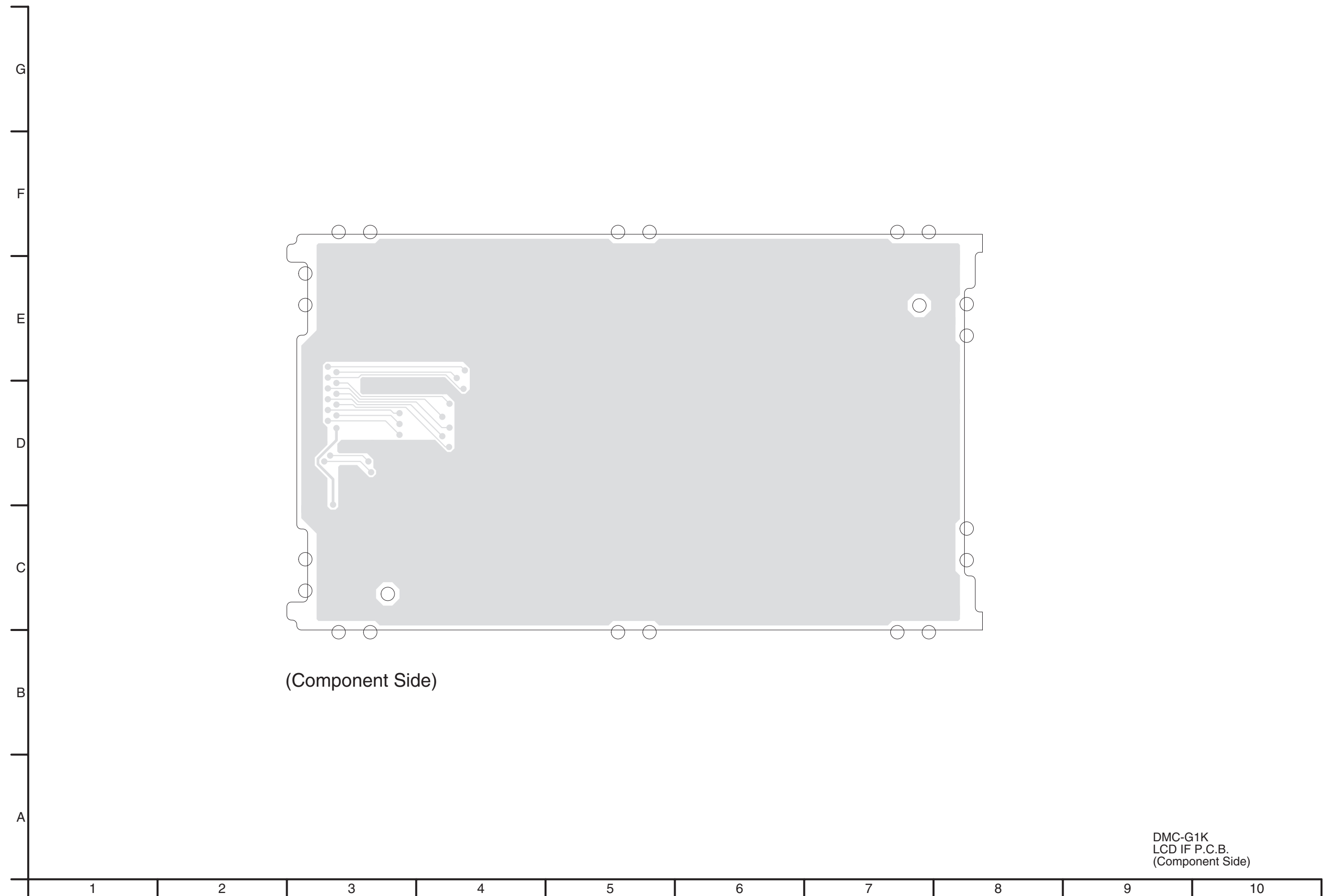

(Component Side)

DMC-G1K  
LCD IF P.C.B.  
(Component Side)

S5.5.2. LCD IF P.C.B. (Foil Side)

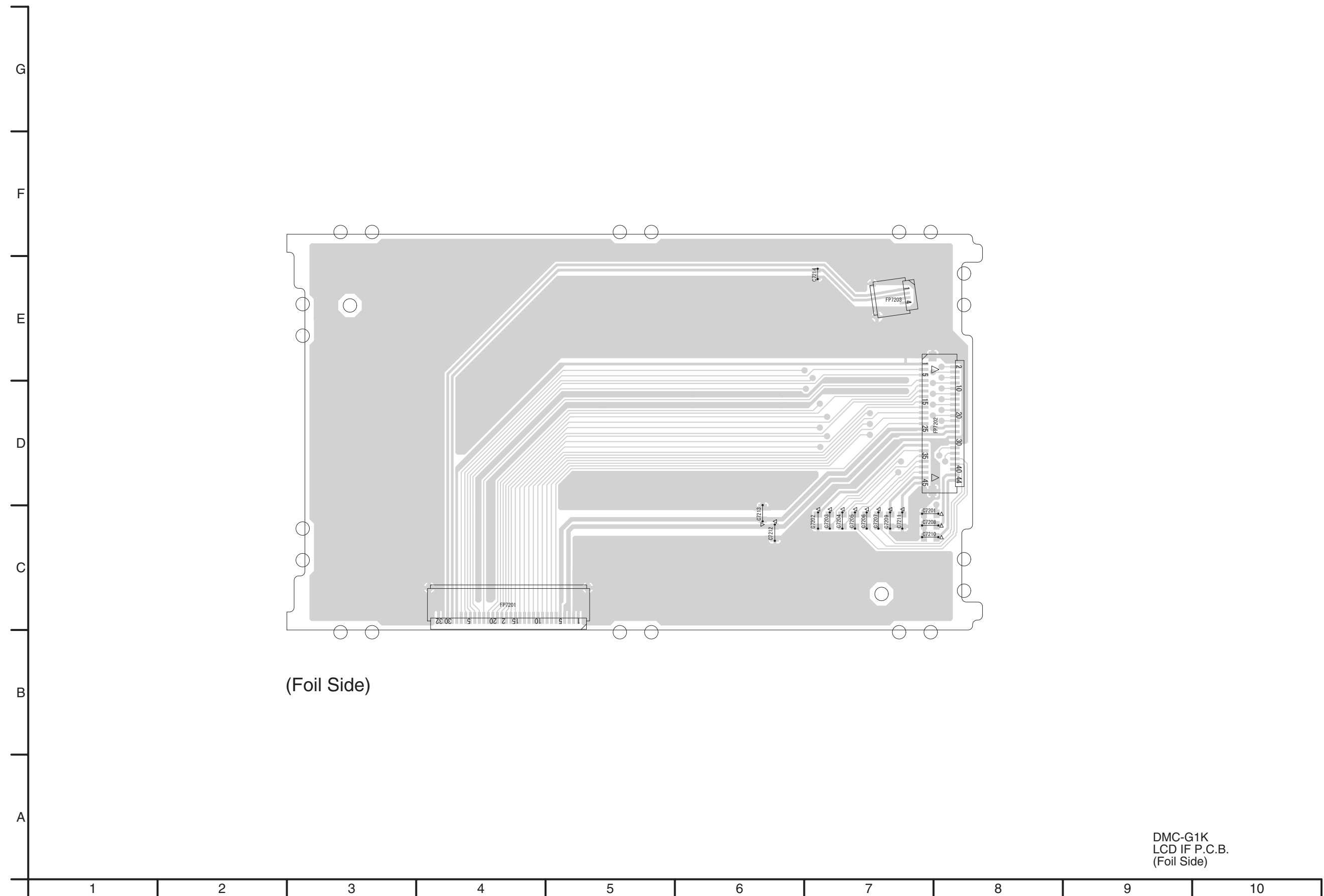

S5.6. Hinge SW P.C.B. / S5.7. Flash Sub P.C.B.

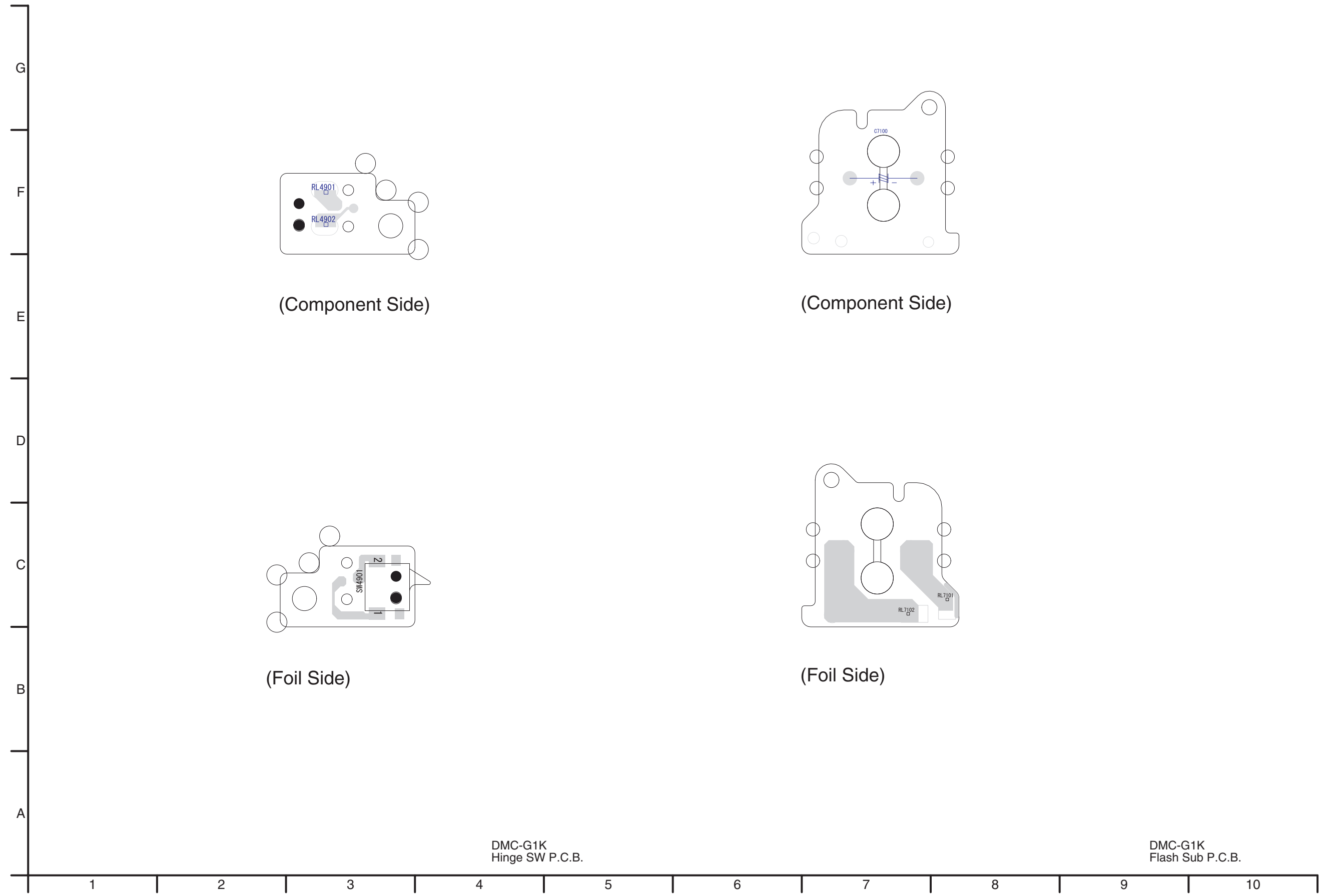

DMC-G1K  
Hinge SW P.C.B.

DMC-G1K  
Flash Sub P.C.B.

## S6. Replacement Parts List

- Note: 1.\* Be sure to make your orders of replacement parts according to this list.
2. IMPORTANT SAFETY NOTICE  
Components identified with the mark  $\triangle$  have the special characteristics for safety.  
When replacing any of these components, use only the same type.
3. Unless otherwise specified,  
All resistors are in OHMS, K=1,000 OHMS. All capacitors are in MICRO-FARADS (uf), P=uuF.
4. The marking (RTL) indicates the retention time is limited for this item. After the discontinuation of this assembly in production, it will no longer be available.
5. Supply of CD-ROM, in accordance with license protection, is allowable as replacement parts only for customers who accidentally damaged or lost their own.

**E.S.D. standards for Electrostatically Sensitive Devices, refer to PREVENTION OF ELECTROSTATIC DISCHARGE (ESD) TO ELECTROSTATICALLY SENSITIVE (ES) DEVICES section.**

**Definition of Parts supplier:**

- 1. Parts marked with [Energy] in the remarks column are supplied from Panasonic Corporation Energy Company.**
- 2. Parts marked with [PAVCSG] in the remarks column are supplied from Panasonic AVC Networks Singapore Pte. Ltd.  
Others are supplied from AVC-CSC-SPC.**

Ref.No.	Part No.	Part Name & Description	Pcs	Remarks
		----- P.C.B. LIST -----		
##	VEP56071A	MAIN P.C.B.	1	(RTL) E.S.D.
##	VEP58063A	FLASH P.C.B.	1	(RTL) E.S.D.[PAVCSG]
##	VEP58067A	AF ASSIST P.C.B.	1	(RTL) E.S.D.[PAVCSG]
##	VEP58065A	LP SW P.C.B.	1	(RTL) [PAVCSG]
##	VEP58066A	REMOTE P.C.B.	1	(RTL) [PAVCSG]
##	VEP59057A	LCD IF P.C.B.	1	(RTL)
##	VEP58068A	HINGE SW P.C.B.	1	(RTL) [PAVCSG]
		--- ELEC. COMPONENTS ---		
##	VEP58063A	FLASH P.C.B.		(RTL) E.S.D.[PAVCSG]
C8501	F1K2J333A029	C.CAPACITOR 630V 0.033U	1	[PAVCSG]
C8502	F1K2J223A029	C.CAPACITOR 630V 0.022U	1	[PAVCSG]
C8503	ECJ0EB1A104K	C.CAPACITOR CH 10V 0.1U	1	[PAVCSG]
C8504	F1K2J102A028	C.CAPACITOR 630V 1000P	1	[PAVCSG]
C8506	ECJ1VB0J105K	C.CAPACITOR CH 6.3V 1U	1	[PAVCSG]
C8507	F1J1A106A023	C.CAPACITOR CH 10V 10U	1	[PAVCSG]
D8501	B0ECGP000005	DIODE	1	[PAVCSG] E.S.D.
D8502	B0HCMP000006	DIODE	1	[PAVCSG] E.S.D.
D8503	MA2YF8000L	DIODE	1	[PAVCSG] E.S.D.
△ F8501	ERBSE3R00U	FUSE 32V 3.0A	1	[PAVCSG]
△ F8502	ERBSE1R50U	FUSE 32V 1.5A	1	[PAVCSG]
FP8505	K1MN07BA0055	CONNECTOR 7P	1	[PAVCSG]
LB8501	JOJGC0000038	FILTER	1	[PAVCSG]
P8502	K1KA02B00307	CONNECTOR 2P	1	[PAVCSG]
P8503	K1KA02B00292	CONNECTOR 2P	1	[PAVCSG]
P8504	K1KA02BA0022	CONNECTOR 2P	1	[PAVCSG]
P8506	K1KA02BA0022	CONNECTOR 2P	1	[PAVCSG]
P8507	K1MN22BA0272	CONNECTOR 22P	1	[PAVCSG]
Q8501	B1JBLP000017	TRANSISTOR	1	[PAVCSG] E.S.D.
Q8502	B1DFCG000020	TRANSISTOR	1	[PAVCSG] E.S.D.
QR8501	XP0431400L	TRANSISTOR-RESISTOR	1	[PAVCSG] E.S.D.
QR8502	UNR32AF00L	TRANSISTOR-RESISTOR	1	[PAVCSG] E.S.D.
QR8503	UNR32A100L	TRANSISTOR-RESISTOR	1	[PAVCSG] E.S.D.
QR8504	UNR32A100L	TRANSISTOR-RESISTOR	1	[PAVCSG] E.S.D.
R8501	ERJ8GEYJ104V	M.RESISTOR CH 1/8W 100K	1	[PAVCSG]
R8502	ERJ8GEYJ105V	M.RESISTOR CH 1/8W 1M	1	[PAVCSG]
R8503	ERJ2GEJ104X	M.RESISTOR CH 1/16W 100K	1	[PAVCSG]
R8504	ERJ3GEYJ220V	M.RESISTOR CH 1/10W 22	1	[PAVCSG]
R8505	ERJ3GEYJ101V	M.RESISTOR CH 1/10W 100	1	[PAVCSG]
R8506	ERJ6RED914V	Surface mounting fixed me	1	[PAVCSG]
R8507	ERJ6RED914V	Surface mounting fixed me	1	[PAVCSG]
R8508	ERJ2RKD304X	M.RESISTOR CH 1/16W 300K	1	[PAVCSG]
R8509	ERJ2RHD163X	M.RESISTOR CH 1/16W 16K	1	[PAVCSG]
R8510	ERJ2GEJ102X	M.RESISTOR CH 1/16W 1K	1	[PAVCSG]
R8511	ERJ2GEJ153X	M.RESISTOR CH 1/16W 15K	1	[PAVCSG]
R8512	ERJ2GE0R00X	M.RESISTOR CH 1/16W 0	1	[PAVCSG]
R8513	ERJ2GEJ152X	M.RESISTOR CH 1/16W 1.5K	1	[PAVCSG]
R8514	ERJ8GEY0R00V	M.RESISTOR CH 1/8W 0	1	[PAVCSG]
R8515	ERJ2GEJ332X	M.RESISTOR CH 1/16W 3.3K	1	[PAVCSG]
R8518	ERJ2GE0R00X	M.RESISTOR CH 1/16W 0	1	[PAVCSG]
R8519	ERJ3GEY0R00V	M.RESISTOR CH 1/10W 0	1	[PAVCSG]
R8520	ERJ3GEY0R00V	M.RESISTOR CH 1/10W 0	1	[PAVCSG]
T8501	G5D1A0000074	SWITCHING TRANSFORMER	1	[PAVCSG]
##	VEP58067A	AF ASSIST P.C.B.		(RTL) E.S.D.[PAVCSG]
D7701	B3ADB0000100	DIODE	1	[PAVCSG] E.S.D.
FP7701	K1MN04BA0208	CONNECTOR 4P	1	[PAVCSG]

Ref.No.	Part No.	Part Name & Description	Pcs	Remarks
##	VEP58065A	LP SW P.C.B.		(RTL) [PAVCSG]
FP7300	K1MN04BA0208	CONNECTOR 4P	1	[PAVCSG]
SW7301	K0L1BA000037	SWITCH	1	[PAVCSG]
##	VEP58066A	REMOTE P.C.B.		(RTL) [PAVCSG]
FP7351	K1MN04BA0208	CONNECTOR 4P	1	[PAVCSG]
JK7351	K2HD104D0002	JACK	1	[PAVCSG]
△ LB7351	JOJCC0000317	FILTER	1	[PAVCSG]
△ LB7352	JOJCC0000317	FILTER	1	[PAVCSG]
R7351	ERJ2GEJ332X	M.RESISTOR CH 1/16W 3.3K	1	[PAVCSG]
ZB7351	K3ZZ00200042	BATTERY HOLDER	1	[PAVCSG]
##	VEP59057A	LCD IF P.C.B.		(RTL)
C7201	ECJ1VB1A105K	C.CAPACITOR CH 10V 1U	1	
C7202	ECJ1VB1A105K	C.CAPACITOR CH 10V 1U	1	
C7203	ECJ1VB1A105K	C.CAPACITOR CH 10V 1U	1	
C7204	ECJ1VB1A105K	C.CAPACITOR CH 10V 1U	1	
C7205	ECJ1VB1A105K	C.CAPACITOR CH 10V 1U	1	
C7206	ECJ1VB1A105K	C.CAPACITOR CH 10V 1U	1	
C7207	ECJ1VB1A105K	C.CAPACITOR CH 10V 1U	1	
C7208	ECJ1VB1A105K	C.CAPACITOR CH 10V 1U	1	
C7209	ECJ1VB1C105K	C.CAPACITOR CH 16V 1U	1	
C7210	ECJ1VB1A105K	C.CAPACITOR CH 10V 1U	1	
C7211	ECJ1VB1A105K	C.CAPACITOR CH 10V 1U	1	
FP7201	K1MN32BA0209	CONNECTOR 32P	1	
FP7202	K1MY45BA0235	CONNECTOR 45P	1	
FP7203	K1MN04BA0208	CONNECTOR 4P	1	
##	VEP58068A	HINGE SW P.C.B.		(RTL) [PAVCSG]
SW4901	K0L1BA000147	SWITCH	1	[PAVCSG]



Ref.No.	Part No.	Part Name & Description	Pcs	Remarks	Ref.No.	Part No.	Part Name & Description	Pcs	Remarks
1	VEP56071A	MAIN P.C.B.	1	(RTL) E.S.D.	B3	VHD2094	SCREW	1	
2	K0RE00900036	TOP CASE UNIT	1		B4	VHD2094	SCREW	1	
2-1	VEK0M97	FLASH UNIT	1		B5	VHD2094	SCREW	1	
3	VGQ0A35	JACK HOLDER	1		B6	VHD2092	SCREW	1	
4	VKF4410	JACK COVER	1	(A)	B7	VHD2092	SCREW	1	
4	VKF4383	JACK COVER	1	(K)	B8	VHD2093	SCREW	1	
4	VKF4413	JACK COVER	1	(R)	B9	VHD2093	SCREW	1	
5	VMP9162	MAIN PCB FLEX. PLATE	1		B10	VHD2093	SCREW	1	
6	VMP9266	FRONT EARTH PLATE	1		B11	VHD2093	SCREW	1	
7	VWJ2063	MAIN-FLASH FPC	1		B12	VHD2093	SCREW	1	
8	VXQ1708	MOUNT BOX UNIT	1		B13	VHD2093	SCREW	1	
9	VYF3227	EYE CUP UNIT	1		B14	VHD2094	SCREW	1	
10	VKF4398	FPC COVER	1		B15	VHD2094	SCREW	1	
11	VKM7693	HINGE ARM COVER TOP	1	(A)	B16	XQN16-BJ4FN	SCREW	1	
11	VKM7655	HINGE ARM COVER TOP	1	(K)	B17	XQN16-BJ4FN	SCREW	1	
11	VKM7701	HINGE ARM COVER TOP	1	(R)	B18	VHD2090	SCREW	1	
12	VKM7694	HINGE ARM COVER BOTTOM	1	(A)	B19	VHD2090	SCREW	1	
12	VKM7656	HINGE ARM COVER BOTTOM	1	(K)	B20	VHD1754	SCREW	1	
12	VKM7702	HINGE ARM COVER BOTTOM	1	(R)	B21	VHD1754	SCREW	1	
13	VYK2Y66	LCD TFT UNIT	1		B26	XQN16-BJ11FN	SCREW	1	
14	VEP59057A	LCD IF P.C.B.	1	(RTL)	B27	XQN16-BJ11FN	SCREW	1	
15	VYK2Y63	LCD CASE UP UNIT	1	(A)	B28	XQN16-BJ4FN	SCREW	1	
15	VYK2Y62	LCD CASE UP UNIT	1	(K)	B29	XQN16-BJ4FN	SCREW	1	
15	VYK2Y64	LCD CASE UP UNIT	1	(R)	B31	VHD2090	SCREW	1	
17	VYK2Y65	LCD SHIELD CASE UNIT	1		B32	VHD2090	SCREW	1	
18	VGQ0B55	LCD BL BEZEL SHEET	1		B33	VHD2090	SCREW	1	
19	VKM7692	LCD CASE BOTTOM	1	(A)	B34	VHD2090	SCREW	1	
19	VKM7623	LCD CASE BOTTOM	1	(K)	B35	VHD2090	SCREW	1	
19	VKM7700	LCD CASE BOTTOM	1	(R)	B36	VHD2090	SCREW	1	
21	VYF3231	LCD HINGE UNIT	1	(A)	B37	VHD2091	SCREW	1	
21	VYF3225	LCD HINGE UNIT	1	(K)	B38	VHD2091	SCREW	1	
21	VYF3232	LCD HINGE UNIT	1	(R)	B39	VHD2091	SCREW	1	
22	VMT1701	LCD CUSHION	1		B40	XQN16-BJ4FJK	SCREW	1	
23	VMT1701	LCD CUSHION	1		B41	XQN16-BJ4FJK	SCREW	1	
△ 28	ML421S/ZT	BUTTON BATTERY	1	(B7351)[Energy]	B42	VHD1679	SCREW	1	
29	VYQ4552	LVF UNIT	1		B43	VHD1679	SCREW	1	
29-1	VGP6235	LVF PANEL	1		B44	VHD1754	SCREW	1	
29-2	VGQ0A40	LVF COVER	1		B45	VHD1754	SCREW	1	
30	L5EDDXL00001	LVF MODULE	1		B46	XQN16-B2FN	SCREW	1	
31	VWJ2061	LVF FPC	1		B47	XQN16-B2FN	SCREW	1	
32	VYQ4487	STRAP (L) UNIT	1		B48	XQN16-B2FN	SCREW	1	
33	VYQ4488	STRAP (R) UNIT	1		B49	XQN16-B2FN	SCREW	1	
					B50	XQN16-BJ4FN	SCREW	1	
					B51	XQN16-BJ4FN	SCREW	1	
					B52	XQN16-BJ4FN	SCREW	1	

Ref.No.	Part No.	Part Name & Description	Pcs	Remarks
100	L0DCDD000014	BUZZER	1	[PAVCSG]
101	VEE1F10	FLASH HARNESS	1	[PAVCSG]
102	VEP58063A	FLASH P.C.B.	1	(RTL) E.S.D.[PAVCSG]
103	VEP58064A	FLASH SUB P.C.B.	1	(RTL) [PAVCSG]
104	VGQ0A15	CAPACITOR HOLDER	1	[PAVCSG]
105	VGQ0A16	BEEPER HOLDER	1	[PAVCSG]
106	VGQ0C80	FLASH PI TAPE	1	[PAVCSG]
107	VGU0D11	BATTERY LOCK KNOB	1	[PAVCSG]
108	VKF4408	DC COVER	1	(A) [PAVCSG]
108	VKF4380	DC COVER	1	(K) [PAVCSG]
108	VKF4411	DC COVER	1	(R) [PAVCSG]
109	VKM7615	BATTERY CASE	1	[PAVCSG]
110	VMB4199	BATTERY LOCK SPRING	1	[PAVCSG]
111	VMB4201	BATTERY SPRING	1	[PAVCSG]
112	VMB4202	EARTH SPRING	1	[PAVCSG]
113	VMB4214	BATTERY DOOR SPRING	1	[PAVCSG]
114	VMP9159	BATTERY PLATE	1	[PAVCSG]
115	VMP9180	SIDE PLATE (L)	1	[PAVCSG]
116	VMS7941	BATTERY DOOR SHAFT	1	[PAVCSG]
117	VYF3233	BATTERY DOOR UNIT	1	(A) [PAVCSG]
117	VYF3224	BATTERY DOOR UNIT	1	(K) [PAVCSG]
117	VYF3234	BATTERY DOOR UNIT	1	(R) [PAVCSG]
▲	F2AZZ2310001	FLASH CHARGING CAPACITOR	1	(C7100)[PAVCSG]
119	K4ZZ04000050	BATTERY CATCHER	1	(P8501)[PAVCSG]
120	KORE00300017	FRONT DIAL UNIT	1	[PAVCSG]
121	VEP58067A	AF ASSIST P.C.B.	1	(RTL) E.S.D.[PAVCSG]
122	VYK2Y58	FRONT CASE UNIT	1	(A) [PAVCSG]
122	VYK2Y56	FRONT CASE UNIT	1	(K) [PAVCSG]
122	VYK2Y60	FRONT CASE UNIT	1	(R) [PAVCSG]
123	VGK3458	GRIP PIECE FRONT	1	[PAVCSG]
124	VGQ0A13	AF LIGHT CASE	1	[PAVCSG]
126	VKF4409	REMOTE COVER	1	(A) [PAVCSG]
126	VKF4379	REMOTE COVER	1	(K) [PAVCSG]
126	VKF4412	REMOTE COVER	1	(R) [PAVCSG]
127	VMB4198	LENS RELEASE BUTTON SPRING	1	[PAVCSG]
128	VMP9191	FRONT EARTH PLATE	1	[PAVCSG]
129	VEP58065A	LP SW P.C.B.	1	(RTL) [PAVCSG]
130	VEP58066A	REMOTE P.C.B.	1	(RTL) [PAVCSG]
131	VGQ0A45	REMOTE HOLDER	1	[PAVCSG]
132	VMP9158	SIDE FRAME (R)	1	[PAVCSG]
133	VWJ2062	FRONT FPC	1	[PAVCSG]
134	VYQ4484	LENS RELEASE BUTTON UNIT	1	[PAVCSG]
135	VYQ4485	SHUTTER RING UNIT	1	[PAVCSG]
136	KORE00900035	REAR OPERATION UNIT	1	[PAVCSG]
▲	L2CH00000028	OPTICAL SENSOR UNIT	1	[PAVCSG]
138	VGQ0A29	GRIP PIECE REAR	1	[PAVCSG]
139	VGQ0A30	LCD LOCK LEVER	1	[PAVCSG]
140	VYK2Y59	REAR CASE UNIT	1	(A) [PAVCSG]
140	VYK2Y57	REAR CASE UNIT	1	(K) [PAVCSG]
140	VYK2Y61	REAR CASE UNIT	1	(R) [PAVCSG]
141	VGU0D13	REAR OPERATION BUTTON	1	[PAVCSG]
142	VGU0D14	REAR DOUBLE BUTTON	1	[PAVCSG]
143	VGU0D47	LVF/LCD BUTTON	1	[PAVCSG]
144	VMB4206	LCD LOCK SPRING	1	[PAVCSG]
145	VMB4207	SD DOOR SPRING	1	[PAVCSG]
146	VMP9181	EYE PIECE PLATE	1	[PAVCSG]
147	VMS7944	SD DOOR SHAFT	1	[PAVCSG]
148	VYF3228	SD DOOR UNIT	1	(A) [PAVCSG]
148	VYF3226	SD DOOR UNIT	1	(K) [PAVCSG]
148	VYF3230	SD DOOR UNIT	1	(R) [PAVCSG]
149	VEE1F12	HINGE SW HARNESS	1	[PAVCSG]
150	VEP58068A	HINGE SW P.C.B.	1	(RTL) [PAVCSG]
151	VMA0W24	HINGE EARTH PLATE	1	[PAVCSG]
154	VGQ0D53	CUSHION	1	[PAVCSG]
155	VGQ0D55	KAPTON TAPE	1	[PAVCSG]
156	VGQ0D50	FRONT FPC SHEET	1	[PAVCSG]

Ref.No.	Part No.	Part Name & Description	Pcs	Remarks
B100	XQN16+BJ4FN	SCREW	1	[PAVCSG]
B101	XQN16+BJ4FN	SCREW	1	[PAVCSG]
B102	XQN16+BJ4FN	SCREW	1	[PAVCSG]
B103	XQN16+BJ4FN	SCREW	1	[PAVCSG]
B105	XQN16+B2FN	SCREW	1	[PAVCSG]
B106	XQN16+B2FN	SCREW	1	[PAVCSG]
B107	XQN16+B2FN	SCREW	1	[PAVCSG]
B108	XQN16+BJ4FN	SCREW	1	[PAVCSG]
B109	XQN16+BJ4FN	SCREW	1	[PAVCSG]
B110	XQN16+BJ4FN	SCREW	1	[PAVCSG]
B111	XQN16+BJ4FN	SCREW	1	[PAVCSG]
B112	XQN16+BJ4FN	SCREW	1	[PAVCSG]
B113	XQN16+BJ4FN	SCREW	1	[PAVCSG]
B114	XQN16+BJ4FN	SCREW	1	[PAVCSG]
B115	VHD1999	SCREW	1	[PAVCSG]
B116	VHD2062-A	SCREW	1	[PAVCSG]
B117	VHD2062-A	SCREW	1	[PAVCSG]
B118	VHD2062-A	SCREW	1	[PAVCSG]
B119	VHD2062-A	SCREW	1	[PAVCSG]
B120	VHD2062-A	SCREW	1	[PAVCSG]
B121	VHD2062-A	SCREW	1	[PAVCSG]
B122	VHD2062-A	SCREW	1	[PAVCSG]
B123	XQN16+B2FN	SCREW	1	[PAVCSG]



Ref.No.	Part No.	Part Name & Description	Pcs	Remarks	Ref.No.	Part No.	Part Name & Description	Pcs	Remarks
400	VPF1316	CAMERA BAG	1		△ 414	VQT1U46	OPERATING BOOK (CHINESE (TRADITIONAL))	1	GC, GH
△ 402	DE-A49BA	AC ADAPTOR/CHARGER	1	PP	△ 414	VQT1U47	OPERATING BOOK (RUSSIAN)	1	GC
△ 402	DE-A49CA	AC ADAPTOR/CHARGER	1	EB, EC, EG, GC, GH, GN, GJ	△ 414	VQT1U48	OPERATING BOOK (ARABIC)	1	GC
△ 402	DE-A49DA	AC ADAPTOR/CHARGER	1	GD, GT	△ 414	VQT1U66	OPERATING BOOK (KOREAN)	1	GD
△ 402	DE-A49EA	AC ADAPTOR/CHARGER	1	GK	△ 414	VQT1U49	OPERATING BOOK (CHINESE (SIMPLIFIED))	1	GK
△ 403	-----	BATTERY	1		△ 414	VQT1U50	OPERATING BOOK (ENGLISH)	1	GN
404	K1HA08CD0019	USB CONNECTION CABLE	1		△ 414	VQT1U65	OPERATING BOOK (CHINESE (TRADITIONAL))	1	GT
405	K1HA08CD0021	VIDEO CABLE	1		416	VPN6742	CUSHION A	1	
406	VFC4355	STRAP	1		417	VPN6743	CUSHION B	1	
407	VFF0438-S	CD-ROM	1	PP, EB, EC, EG, GC, GD, GH, GN, GT, GJ See "Notes"	418	VPN6744	CUSHION C	1	
407	VFF0439-S	CD-ROM	1	GK See "Notes"	△ 420	K2CT3CA00004	AC CORD W/PLUG	1	EB, GC, GH
408	VPK3645	PACKING CASE	1	PP	421	VPF1321	LENS BAG	1	
408	VPK3646	PACKING CASE	1	EB, EC, EG, GC, GD, GH, GN, GT, GJ	422	VYC0981	LENS HOOD	1	
408	VPK3663	PACKING CASE	1	GK	423	VFC4357	LENS STORAGE BAG	1	
409	VQL1V18	COLOR LABEL	1	PP-A	424	VFC4315	LENS CAP REAR	1	
409	VQL1V20	COLOR LABEL	1	EB-A, EC-A, EG-A, GC-A, GH-A	425	VYF3201	LENS CAP FRONT	1	
409	VQL1V22	COLOR LABEL	1	GK-A	△ 426	K2C02CA00006	AC CORD W/PLUG	1	EC, EG, GC
409	VQL1V19	COLOR LABEL	1	PP-R	△ 426	K2CP2YY00001	AC CORD W/PLUG	1	GJ
409	VQL1V21	COLOR LABEL	1	EB-R, EC-R, EG-R, GC-R, GH-R	△ 427	K2CR2CA00003	AC CORD W/PLUG	1	GD
409	VQL1V23	COLOR LABEL	1	GK-R	△ 428	K2CJ2DA00008	AC CORD W/PLUG	1	GN
411	VPF1132	BAG, POLYETHYLENE	1	PP, EC, EG, GC, GH	△ 429	K2CA2CA00020	AC CORD W/PLUG	1	GK
411	VPF1294	BAG, POLYETHYLENE	1	GK, EB, GD, GN, GT, GJ	△ 429	JXS0102	AC CORD W/PLUG	1	PP
412	VQT1U52	O/I SOFTWARE (ENGLISH/CANADIAN FRENCH/ SPANISH/PORTUGUESE)	1	PP	△ 429	K2CA2CA00027	AC CORD W/PLUG	1	GT
412	VQT1U54	O/I SOFTWARE (SPANISH/PORTUGUESE/SWEDISH/ DANISH)	1	EC	446	VKF4385	BODY CAP	1	
412	VQT1U55	O/I SOFTWARE (ENGLISH)	1	EB, GN, GJ	447	VQL1V18	COLOR LABEL	1	PP-A
412	VQT1U53	O/I SOFTWARE (GERMAN/FRENCH/ITALIAN/ DUTCH)	1	EG	447	VQL1V20	COLOR LABEL	1	EB-A, EC-A, EG-A, GC-A, GH-A
412	VQT1U57	O/I SOFTWARE (ENGLISH/ CHINESE (TRADITIONAL) / RUSSIAN/ARABIC)	1	GC, GH	447	VQL1V22	COLOR LABEL	1	GK-A
412	VQT1U84	O/I SOFTWARE (KOREAN)	1	GD	447	VQL1V19	COLOR LABEL	1	PP-R
412	VQT1U58	O/I SOFTWARE (CHINESE (SIMPLIFIED))	1	GK	447	VQL1V21	COLOR LABEL	1	EB-R, EC-R, EG-R, GC-R, GH-R
412	VQT1U80	O/I SOFTWARE (CHINESE (TRADITIONAL))	1	GT	447	VQL1V23	COLOR LABEL	1	GK-R
△ 414	VQT1U32	OPERATING BOOK (ENGLISH)	1	PP	448	VQL1V18	COLOR LABEL	1	PP-A
△ 414	VQT1U33	OPERATING BOOK (CANADIAN FRENCH)	1	PP	448	VQL1V20	COLOR LABEL	1	EB-A, EC-A, EG-A, GC-A, GH-A
△ 414	VQT1U34	OPERATING BOOK (SPANISH)	1	PP	448	VQL1V22	COLOR LABEL	1	GK-A
△ 414	VQT1U35	OPERATING BOOK (PORTUGUESE)	1	PP	448	VQL1V19	COLOR LABEL	1	PP-R
△ 414	VQT1U44	OPERATING BOOK (ENGLISH)	1	EB	448	VQL1V21	COLOR LABEL	1	EB-R, EC-R, EG-R, GC-R, GH-R
△ 414	VQT1U40	OPERATING BOOK (SPANISH)	1	EC	448	VQL1V23	COLOR LABEL	1	GK-R
△ 414	VQT1U41	OPERATING BOOK (PORTUGUESE)	1	EC	449	VPQ0276	AIR-CAP SHEET	1	
△ 414	VQT1U42	OPERATING BOOK (SWEDISH)	1	EC					
△ 414	VQT1U43	OPERATING BOOK (DANISH)	1	EC					
△ 414	VQT1U36	OPERATING BOOK (GERMAN)	1	EG					
△ 414	VQT1U37	OPERATING BOOK (FRENCH)	1	EG					
△ 414	VQT1U38	OPERATING BOOK (ITALIAN)	1	EG					
△ 414	VQT1U39	OPERATING BOOK (DUTCH)	1	EG					
△ 414	VQT1U45	OPERATING BOOK (ENGLISH)	1	GC, GH, GJ					

# S7. Exploded View

## S7.1. Frame and Casing Section

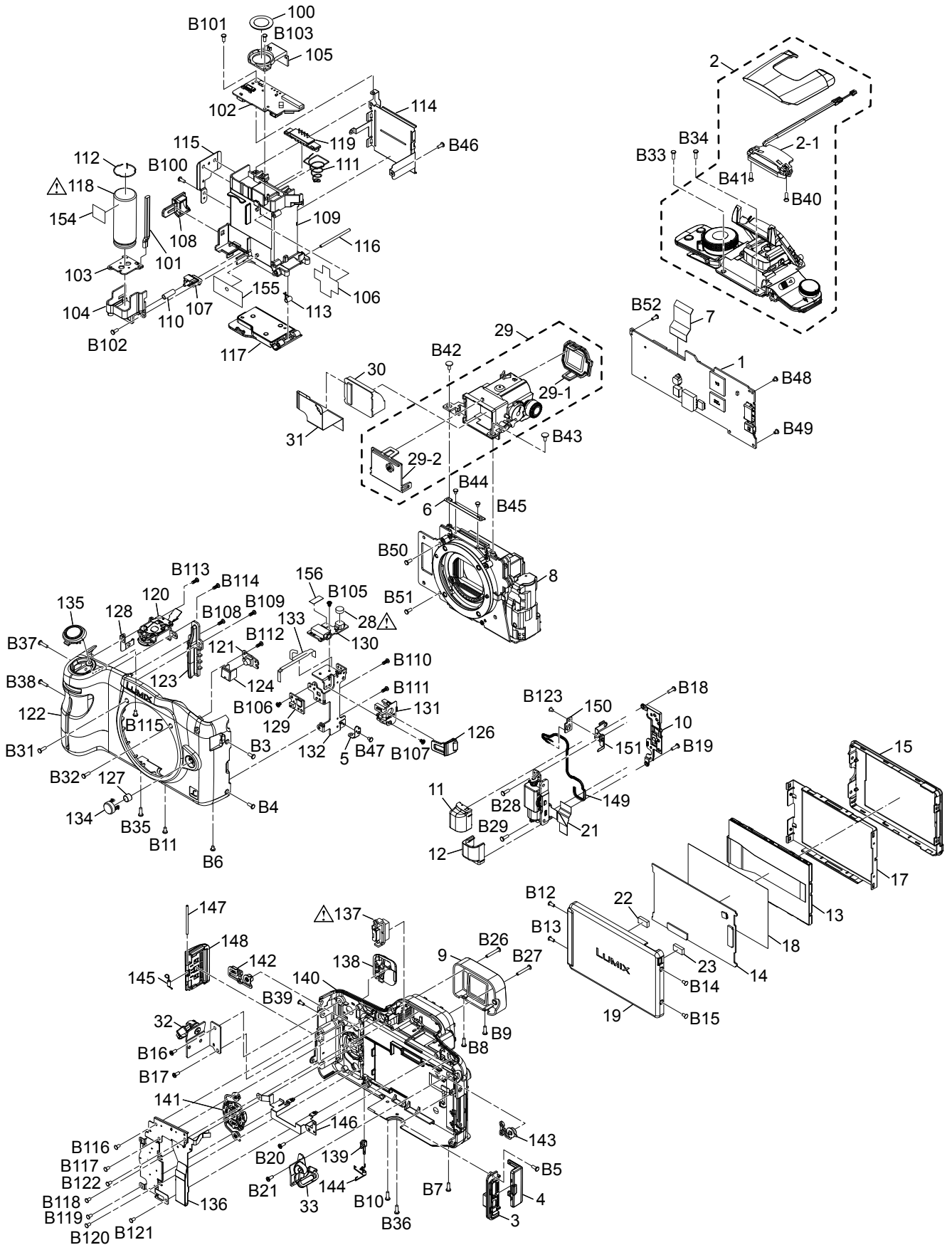

## S7.2. Camera Lens Section

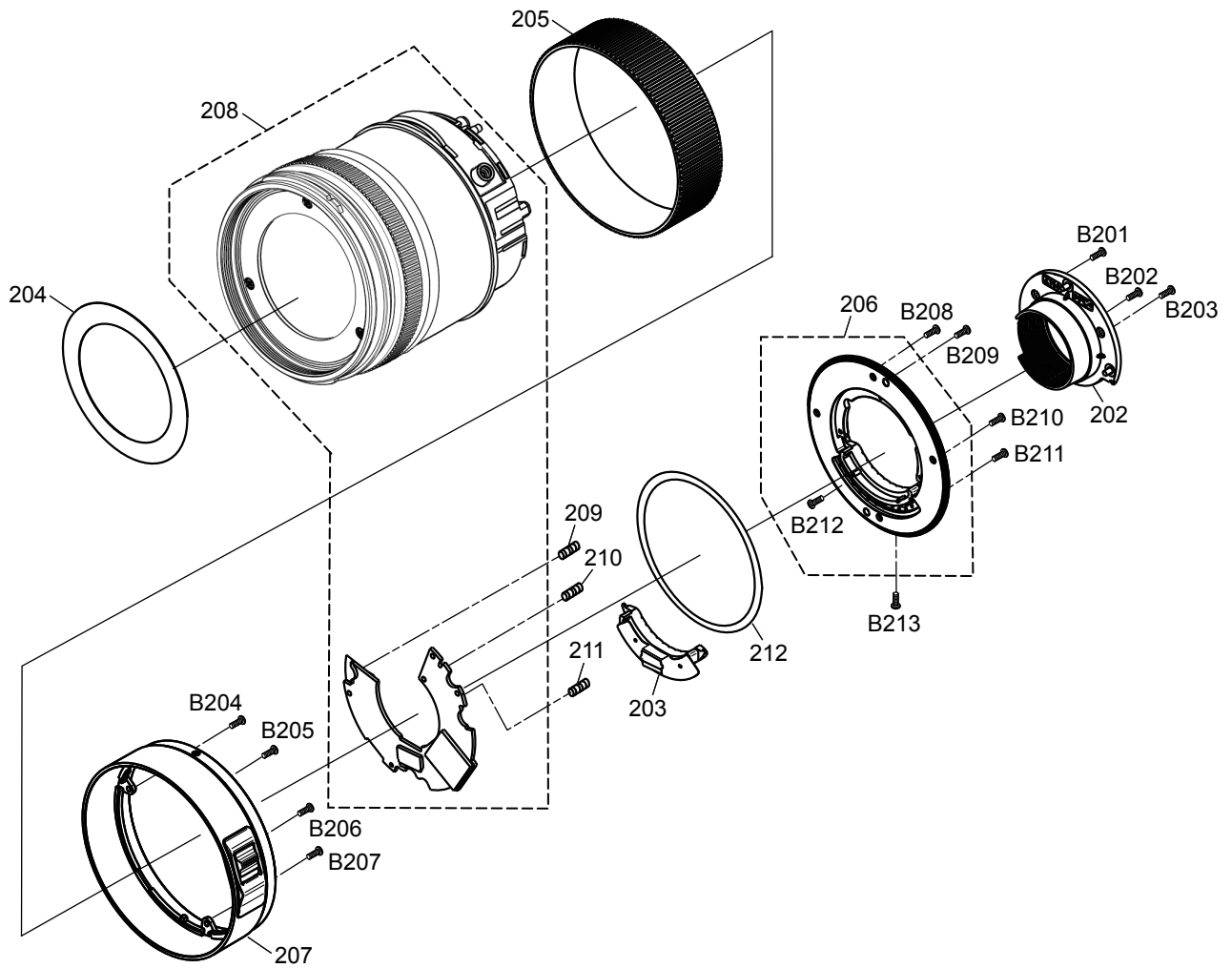

### S7.3. Packing Parts and Accessories Section

