

# Service Manual

Digital Camera

**LUMIX**  
LEICA  
DC VARIO-ELMARIT

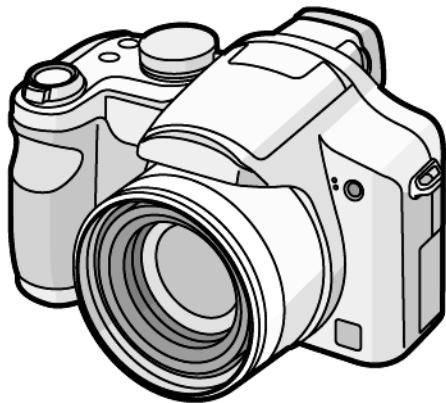

**DMC-FZ8P**  
**DMC-FZ8PC**  
**DMC-FZ8PL**  
**DMC-FZ8EB**  
**DMC-FZ8EE**  
**DMC-FZ8EF**  
**DMC-FZ8EG**  
**DMC-FZ8EGM**  
**DMC-FZ8GC**  
**DMC-FZ8GD**  
**DMC-FZ8GK**  
**DMC-FZ8GN**  
**DMC-FZ8GT**  
**DMC-FZ8SG**

Vol. 1

Colour

(S).....Silver Type (except PL/GD/GT)

(K).....Black Type

**⚠ WARNING**

This service information is designed for experienced repair technicians only and is not designed for use by the general public. It does not contain warnings or cautions to advise non-technical individuals of potential dangers in attempting to service a product. Products powered by electricity should be serviced or repaired only by experienced professional technicians. Any attempt to service or repair the product or products dealt with in this service information by anyone else could result in serious injury or death.

**Panasonic®**

© 2007 Matsushita Electric Industrial Co., Ltd. All rights reserved. Unauthorized copying and distribution is a violation of law.

# TABLE OF CONTENTS

	PAGE	PAGE
<b>1 Safety Precaution</b> .....	<b>3</b>	
1.1. General Guidelines .....	3	
1.2. Leakage Current Cold Check .....	3	
1.3. Leakage Current Hot Check (See Figure 1.) .....	3	
1.4. How to Discharge the Capacitor on Main PCB .....	4	
<b>2 Warning</b> .....	<b>5</b>	
2.1. Prevention of Electro Static Discharge (ESD) to Electrostatically Sensitive (ES) Devices .....	5	
2.2. How to Recycle the Lithium Ion Battery (U.S. Only) .....	5	
2.3. Caution for AC Cord (For EB/GC/SG) .....	6	
2.4. How to Replace the Lithium Battery .....	7	
<b>3 Service Navigation</b> .....	<b>8</b>	
3.1. Introduction .....	8	
3.2. General Description About Lead Free Solder (PbF) .....	8	
3.3. Important Notice 1: (Other than U.S.A. and Canadian Market) .....	8	
3.4. How to Define the Model Suffix (NTSC or PAL model) .....	9	
<b>4 Specifications</b> .....	<b>12</b>	
<b>5 Location of Controls and Components</b> .....	<b>13</b>	
<b>6 Service Mode</b> .....	<b>15</b>	
6.1. Error Code Memory Function .....	15	
6.2. Confirmation of Firmware Version .....	18	
<b>7 Service Fixture &amp; Tools</b> .....	<b>19</b>	
7.1. Service Fixture and Tools .....	19	
7.2. When Replacing the Main PCB .....	20	
7.3. Service Position .....	20	
<b>8 Disassembly and Assembly Instructions</b> .....	<b>22</b>	
8.1. Disassembly Flow Chart .....	22	
8.2. PCB Location .....	22	
8.3. Disassembly Procedure .....	23	
8.4. Disassembly/Assembly Procedure for the Lens .....	27	
8.5. Removal of the CCD Unit .....	31	
<b>9 Measurements and Adjustments</b> .....	<b>32</b>	
9.1. Matrix Chart for Replaced Part and Necessary Adjustment .....	32	
<b>10 Maintenance</b> .....	<b>33</b>	
10.1. Cleaning Lens, Viewfinder and LCD Panel .....	33	

# 1 Safety Precaution

## 1.1. General Guidelines

### 1. IMPORTANT SAFETY NOTICE

There are special components used in this equipment which are important for safety. These parts are marked by

 in the Schematic Diagrams, Circuit Board Layout, Exploded Views and Replacement Parts List. It is essential that these critical parts should be replaced with manufacturer's specified parts to prevent X-RADIATION, shock, fire, or other hazards. Do not modify the original design without permission of manufacturer.

2. An Isolation Transformer should always be used during the servicing of AC Adaptor whose chassis is not isolated from the AC power line. Use a transformer of adequate power rating as this protects the technician from accidents resulting in personal injury from electrical shocks. It will also protect AC Adaptor from being damaged by accidental shorting that may occur during servicing.
3. When servicing, observe the original lead dress. If a short circuit is found, replace all parts which have been overheated or damaged by the short circuit.
4. After servicing, see to it that all the protective devices such as insulation barriers, insulation papers shields are properly installed.
5. After servicing, make the following leakage current checks to prevent the customer from being exposed to shock hazards.

## 1.2. Leakage Current Cold Check

1. Unplug the AC cord and connect a jumper between the two prongs on the plug.
2. Measure the resistance value, with an ohmmeter, between the jumpered AC plug and each exposed metallic cabinet part on the equipment such as screwheads, connectors, control shafts, etc. When the exposed metallic part has a return path to the chassis, the reading should be between  $1\text{ M}\Omega$  and  $5.2\text{ M}\Omega$ . When the exposed metal does not have a return path to the chassis, the reading must be infinity.

## 1.3. Leakage Current Hot Check (See Figure 1.)

1. Plug the AC cord directly into the AC outlet. Do not use an isolation transformer for this check.
2. Connect a  $1.5\text{ k}\Omega$ ,  $10\text{ W}$  resistor, in parallel with a  $0.15\text{ }\mu\text{F}$  capacitor, between each exposed metallic part on the set and a good earth ground, as shown in Figure 1.
3. Use an AC voltmeter, with  $1\text{ k}\Omega/\text{V}$  or more sensitivity, to measure the potential across the resistor.
4. Check each exposed metallic part, and measure the voltage at each point.
5. Reverse the AC plug in the AC outlet and repeat each of the above measurements.
6. The potential at any point should not exceed  $0.75\text{ V RMS}$ . A leakage current tester (Simpson Model 229 or equivalent) may be used to make the hot checks, leakage current must not exceed  $1/2\text{ mA}$ . In case a measurement is outside of the limits specified, there is a possibility of a shock hazard, and the equipment should be repaired and rechecked before it is returned to the customer.

Hot-Check Circuit



Figure. 1

## 1.4. How to Discharge the Capacitor on Main PCB

- This unit equipped with two pieces of capacitors as flash charging capacitors.  
“Either one of the capacitor discharging operation” makes discharging for others as well.

### CAUTION:

1. **Be sure to discharge the capacitor on MAIN PCB.**
2. **Be careful of the high voltage circuit on MAIN PCB when servicing.**

### [Discharging Procedure]

1. Refer to the disassemble procedure and Remove the necessary parts/unit.
2. Put the insulation tube onto the lead part of Resistor (ERG5SJ102:1k $\Omega$  /5W).  
(an equivalent type of resistor may be used.)
3. Put the resistor between both terminals of capacitor on MAIN PCB for approx. 5 seconds.
4. After discharging confirm that the capacitor voltage is lower than 10V using a voltmeter.

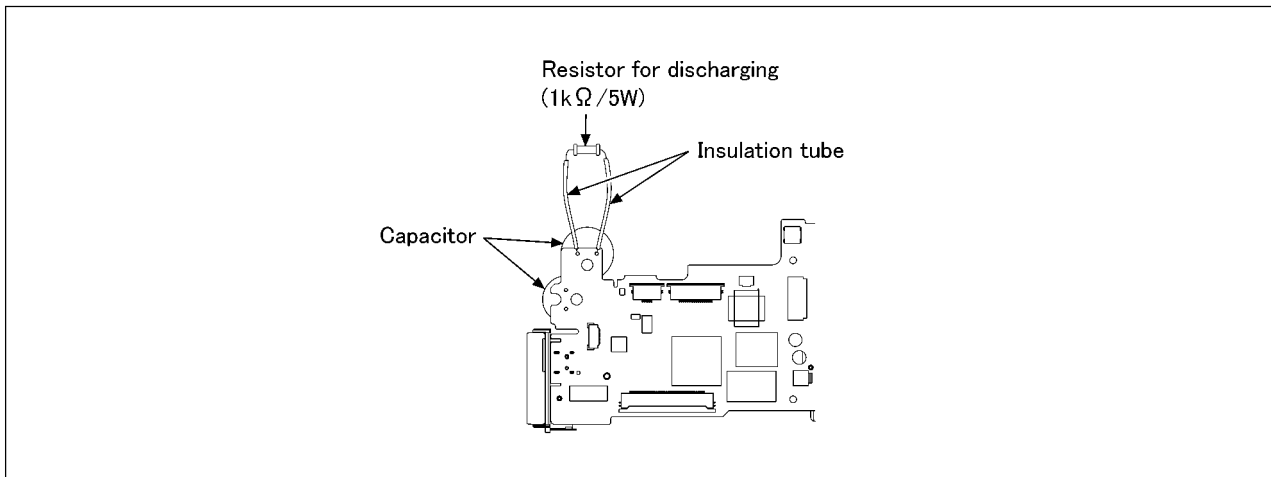

Fig. F1

## 2 Warning

### 2.1. Prevention of Electro Static Discharge (ESD) to Electrostatically Sensitive (ES) Devices

Some semiconductor (solid state) devices can be damaged easily by static electricity. Such components commonly are called Electrostatically Sensitive (ES) Devices.

Examples of typical ES devices are CCD image sensor, IC (integrated circuits) and some field-effect transistors and semiconductor "chip" components.

The following techniques should be used to help reduce the incidence of component damage caused by electro static discharge (ESD).

1. Immediately before handling any semiconductor component or semiconductor-equipped assembly, drain off any ESD on your body by touching a known earth ground. Alternatively, obtain and wear a commercially available discharging ESD wrist strap, which should be removed for potential shock reasons prior to applying power to the unit under test.
2. After removing an electrical assembly equipped with ES devices, place the assembly on a conductive surface such as aluminum foil, to prevent electrostatic charge buildup or exposure of the assembly.
3. Use only a grounded-tip soldering iron to solder or unsolder ES devices.
4. Use only an antistatic solder removal device. Some solder removal devices not classified as "antistatic (ESD protected)" can generate electrical charge sufficient to damage ES devices.
5. Do not use freon-propelled chemicals. These can generate electrical charges sufficient to damage ES devices.
6. Do not remove a replacement ES device from its protective package until immediately before you are ready to install it. (Most replacement ES devices are packaged with leads electrically shorted together by conductive foam, aluminum foil or comparable conductive material).
7. Immediately before removing the protective material from the leads of a replacement ES device, touch the protective material to the chassis or circuit assembly into which the device will be installed.

**CAUTION :**

Be sure no power is applied to the chassis or circuit, and observe all other safety precautions.

8. Minimize bodily motions when handling unpackaged replacement ES devices. (Otherwise harmless motion such as the brushing together of your clothes fabric or the lifting of your foot from a carpeted floor can generate static electricity (ESD) sufficient to damage an ES device).

### 2.2. How to Recycle the Lithium Ion Battery (U.S. Only)

**ENGLISH**



A lithium ion/polymer battery that is recyclable powers the product you have purchased. Please call 1-800-8-BATTERY for information on how to recycle this battery.

**FRANÇAIS**



L'appareil que vous vous êtes procuré est alimenté par une batterie au lithium-ion/polymère recyclable. Pour des renseignements sur le recyclage de la batterie, veuillez composer le 1-800-8-BATTERY.

## 2.3. Caution for AC Cord (For EB/GC/SG)

### 2.3.1. Information for Your Safety

#### IMPORTANT

Your attention is drawn to the fact that recording of pre-recorded tapes or discs or other published or broadcast material may infringe copyright laws.

#### WARNING

To reduce the risk of fire or shock hazard, do not expose this equipment to rain or moisture.

#### CAUTION

To reduce the risk of fire or shock hazard and annoying interference, use the recommended accessories only.

#### FOR YOUR SAFETY

##### DO NOT REMOVE THE OUTER COVER

To prevent electric shock, do not remove the cover. No user serviceable parts inside. Refer servicing to qualified service personnel.

### 2.3.2. Caution for AC Mains Lead

For your safety, please read the following text carefully.

This appliance is supplied with a moulded three-pin mains plug for your safety and convenience.

A 5-ampere fuse is fitted in this plug.

Should the fuse need to be replaced please ensure that the replacement fuse has a rating of 5 amperes and it is approved by ASTA or BSI to BS1362

Check for the ASRA mark or the BSI mark on the body of the fuse.



If the plug contains a removable fuse cover you must ensure that it is refitted when the fuse is replaced.

If you lose the fuse cover, the plug must not be used until a replacement cover is obtained.

A replacement fuse cover can be purchased from your local Panasonic Dealer.

If the fitted moulded plug is unsuitable for the socket outlet in your home then the fuse should be removed and the plug cut off and disposed of safely.

There is a danger of severe electrical shock if the cut off plug is inserted into any 13-ampere socket.

If a new plug is to be fitted please observe the wiring code as shown below.

If in any doubt, please consult a qualified electrician.

### 2.3.2.1. Important

The wires in this mains lead are coloured in accordance with the following code:

Blue	Neutral
Brown	Live

As the colours of the wires in the mains lead of this appliance may not correspond with the coloured markings identifying the terminals in your plug, proceed as follows:

The wire which is coloured BLUE must be connected to the terminal in the plug which is marked with the letter N or coloured BLACK.

The wire which is coloured BROWN must be connected to the terminal in the plug which is marked with the letter L or coloured RED.

Under no circumstances should either of these wires be connected to the earth terminal of the three pin plug, marked with the letter E or the Earth Symbol.

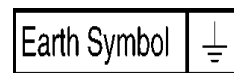

### 2.3.2.2. Before Use

Remove the Connector Cover as follows.



### 2.3.2.3. How to Replace the Fuse

1. Remove the Fuse Cover with a screwdriver.



2. Replace the fuse and attach the Fuse cover.



## 2.4. How to Replace the Lithium Battery

### 2.4.1. Replacement Procedure

1. Remove the MAIN PCB. (Refer to Disassembly Procedures.)
2. Remove the Lithium battery (Ref. No. "B9101" at component side of MAIN PCB) and then replace it into new one.

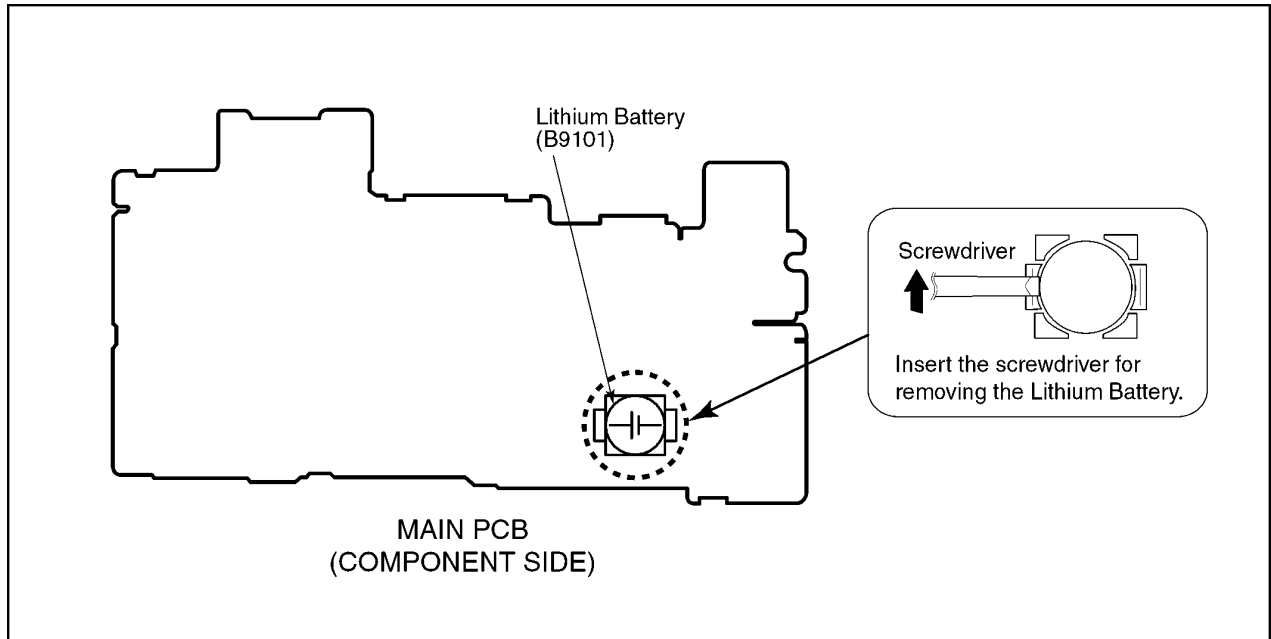

#### NOTE:

This Lithium battery is a critical component.

(Type No.: ML-421S/ZT **Manufactured by Matsushita Battery Industrial Co.,Ltd.**)

It must never be subjected to excessive heat or discharge.

It must therefore only be fitted in requirement designed specifically for its use.

Replacement batteries must be of same type and manufacture.

They must be fitted in the same manner and location as the original battery, with the correct polarity contacts observed.

Do not attempt to re-charge the old battery or re-use it for any other purpose.

It should be disposed of in waste products destined for burial rather than incineration.

#### (For English)

### CAUTION

Danger of explosion if battery is incorrectly replaced.

Replace only with the same or equivalent type recommended by the manufacturer.

Dispose of used batteries according to the manufacturer's instructions.

#### (For German)

### ACHTUNG

Explosionsgefahr bei falschem Anbringen der Batterie. Ersetzen Sie nur mit einem äquivalentem vom Hersteller empfohlenem Typ.

Behandeln Sie gebrauchte Batterien nach den Anweisungen des Herstellers.

#### (For French)

### MISE EN GARDE

Une batterie de remplacement inappropriée peut exploser. Ne remplacez qu'avec une batterie identique ou d'un type recommandé par le fabricant. L'élimination des batteries usées doit être faite conformément aux instructions du manufacturier.

#### NOTE:

Above caution is applicable for a battery pack which is for DMC-FZ8 series, as well.

## 3 Service Navigation

### 3.1. Introduction

This service manual contains technical information, which allow service personnel's to understand and service this model.

Please place orders using the parts list and not the drawing reference numbers.

If the circuit is changed or modified, the information will be followed by service manual to be controlled with original service manual.

### 3.2. General Description About Lead Free Solder (PbF)

The lead free solder has been used in the mounting process of all electrical components on the printed circuit boards used for this equipment in considering the globally environmental conservation.

The normal solder is the alloy of tin (Sn) and lead (Pb). On the other hand, the lead free solder is the alloy mainly consists of tin (Sn), silver (Ag) and Copper (Cu), and the melting point of the lead free solder is higher approx.30°C (86°F) more than that of the normal solder.

#### Distinction of PCB Lead Free Solder being used

The letter of "PbF" is printed either foil side or components side on the PCB using the lead free solder.(See right figure)
---

PbF
-----

#### Service caution for repair work using Lead Free Solder (PbF)

- The lead free solder has to be used when repairing the equipment for which the lead free solder is used.  
(Definition: The letter of "PbF" is printed on the PCB using the lead free solder.)
- To put lead free solder, it should be well molten and mixed with the original lead free solder.
- Remove the remaining lead free solder on the PCB cleanly for soldering of the new IC.
- Since the melting point of the lead free solder is higher than that of the normal lead solder, it takes the longer time to melt the lead free solder.
- Use the soldering iron (more than 70W) equipped with the temperature control after setting the temperature at 350±30°C (662±86°F).

#### Recommended Lead Free Solder (Service Parts Route.)

- The following 3 types of lead free solder are available through the service parts route.
  - RFKZ03D01K----- (0.3mm 100g Reel)
  - RFKZ06D01K----- (0.6mm 100g Reel)
  - RFKZ10D01K----- (1.0mm 100g Reel)

#### Note

\* Ingredient: tin (Sn) 96.5%, silver (Ag) 3.0%, Copper (Cu) 0.5%, Cobalt (Co) / Germanium (Ge) 0.1 to 0.3%

### 3.3. Important Notice 1:(Other than U.S.A. and Canadian Market)

1. The service manual does not contain the following information, because of the impossibility of servicing at component level without concerned equipment/facilities.
  - a. Schematic diagram, Block Diagram and PCB layout of MAIN PCB.
  - b. Parts list for individual parts for MAIN PCB.When a part replacement is required for repairing MAIN PCB , replace as an assembled parts. (Main PCB)
2. The following category is/are recycle module part. please send it/them to Central Repair Center.
  - MAIN PCB (VEP56045A) : Excluding replacement of Lithium Battery



### 3.4. How to Define the Model Suffix (NTSC or PAL model)

There are seven kinds of DMC-FZ8, regardless of the colours.







- a) DMC-FZ8S
- b) DMC-FZ8P/PC
- c) DMC-FZ8EB/EF/EG/EGM/GN
- d) DMC-FZ8EE
- e) DMC-FZ8GD
- f) DMC-FZ8GT
- g) DMC-FZ8PL/GC/GK/SG

(DMC-FZ8S is exclusively Japan domestic model.)

What is the difference is that the "INITIAL SETTINGS" data which is stored in Flash ROM mounted on Main PCB.

#### 3.4.1. Defining methods:

To define the model suffix to be serviced, refer to the nameplate which is putted on the bottom side of the Unit.

<p><b>a) DMC-FZ8S</b> DMC-FZ8S is exclusively Japan domestic model.</p> <p><b>b) DMC-FZ8P/PC</b> The nameplate for these models show the following Safty registration mark.</p> <div style="border: 1px solid black; padding: 5px; text-align: center;">  </div> <p><b>c) DMC-FZ8EB/EF/EG/EGM/GN</b> The nameplate for these models show the following Safty registration mark.</p> <div style="border: 1px solid black; padding: 5px; text-align: center;">  </div> <p><b>d) DMC-FZ8EE</b> The nameplate for this model show the following Safty registration mark.</p> <div style="border: 1px solid black; padding: 5px; text-align: center;">  </div> <p><b>e) DMC-FZ8GD</b> The nameplate for this model show the following Safty registration mark.</p> <div style="border: 1px solid black; padding: 5px; text-align: center;">  </div> <p><b>f) DMC-FZ8GT</b> The nameplate for this model show the following Safty registration mark.</p> <div style="border: 1px solid black; padding: 5px; text-align: center;">  </div> <p><b>g) DMC-FZ8PL/GC/GK/SG</b> The nameplate for these models do not show any above Safty registration mark.</p>	<div style="border: 1px solid black; padding: 10px;">  <p style="text-align: center; border: 1px solid black; padding: 2px;">Safty registration mark</p> </div>
--	--

**NOTE:**

After replacing the MAIN PCB, be sure to achieve adjustment.

The adjustment instruction is available at "software download" on the "Support Information from NWBG/VDBG-PAVC" web-site in "TSN system", together with Maintenance software.

### 3.4.2. INITIAL SETTINGS:

When you replace the Main PCB, be sure to perform the initial settings after achieving the adjustment by ordering the following procedure in accordance with model suffix of the unit.

#### 1. IMPORTANT NOTICE:

Before proceeding Initial settings, be sure to read the following CAUTIONS.

#### CAUTION 1 (Initial Settings)

**DO NOT** select "NONE(JAPAN)" or "P"(North America) if need to select "EG/EGM/PL/GD/GC/SG/GT/GK/EF/EB/EE/GN and PC".

Otherwise, once "NONE(JAPAN)" or "P"(North America) are selected, "EG/EGM/PL/GD/GC/SG/GT/GK/EF/EB/EE/GN and PC" will not displayed, thus, RE-Settings (changing area) can not be made.

#### CAUTION 2 (Picture back up from "Built-in Memory")

This unit employs "Built-in Memory" for picture image data recording.(Approx.27MB)  
Be sure to make picture data back up (i.e., Copying to SD memory card), before proceeding "INITIAL SETTINGS".

Once "INITIAL SETTINGS" has been carried out, all image data stored at "Built-in Memory" is erased.

#### 2. PROCEDURES:

- Preparation. Proceed the picture back up from the unit (Refer to above "CAUTION 2")
- **Step 1. The temporary cancellation of initial setting:**  
Set the mode dial to "[ P ]".  
While keep pressing [ Optical Image Stabilizer ] and "[ UP ] of Cross key" simultaneously, turn the Power on.
- **Step 2. The cancellation of initial setting:**  
Set the mode dial to "[ Playback ]".  
Press [ Optical Image Stabilizer ] and "[ UP ] of Cross key" simultaneously, then turn the Power off.
- **Step 3. Turn the Power on:**  
Set the mode dial to "[ P ]", and then turn the Power on.
- **Step 4. Display the INITIAL SETTING:**  
While keep pressing [ MENU ] and "[ RIGHT ] of Cross key" simultaneously, turn the Power off.

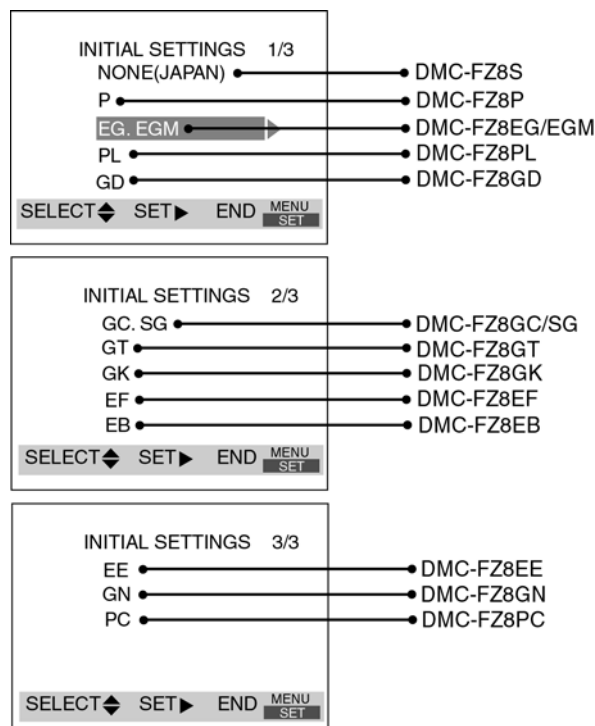

• **Step 5. Set the INITIAL SETTING: (Refer to “CAUTION 1”)**

**[Caution for before settings]**

Once "NONE(JAPAN)" (Area for Japan) or "P" (Area for North America) is selected with "INITIAL SETTINGS", other areas will not be displayed even if "INITIAL SETTINGS" menu is displayed again, thus, the area can not be changed.

Select the area carefully.

Select the area with pressing “[ UP ] / [ DOWN ] of Cross key”, and then press the “[ RIGHT ] of Cross key”.

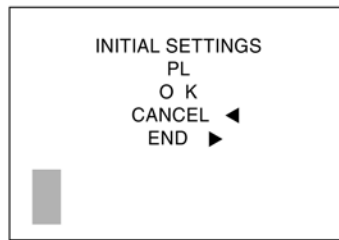

The only set area is displayed, and then press the “[ RIGHT ] of Cross key” after confirmation.

(The unit is powered off automatically.)

Confirm the display of “PLEASE SET THE CLOCK” in English when the unit is turned on again.

• **Step 6. CONFIRMATION:**

The display shows “PLEASE SET THE CLOCK” when turn the Power on again.

When the unit is connected to PC with USB cable, it is detected as removable media.

(When the “GT” or “GK” model suffix is selected, the display shows “PLEASE SET THE CLOCK” in Chinese.)

1) As for your reference Default setting condition is given in the following table.

• **Default setting (After “INITIAL SETTINGS”)**

	MODEL	VIDEO OUTPUT	LANGUAGE	DATE	REMARKS
a)	DMC-FZ8S	NTSC	Japanese	Year/Month/Date	
b)	DMC-FZ8P/PC/PL	NTSC	English	Month/Date/Year	
c)	DMC-FZ8EB/EG/EGM/GC/GN/SG	PAL	English	Date/Month/Year	
d)	DMC-FZ8EF	PAL	French	Date/Month/Year	
e)	DMC-FZ8EE	PAL	Russian	Date/Month/Year	
f)	DMC-FZ8GK	PAL	Chinese (simplified)	Year/Month/Date	
g)	DMC-FZ8GT	NTSC	Chinese (traditional)	Year/Month/Date	
h)	DMC-FZ8GD	NTSC	Korean	Year/Month/Date	

# 4 Specifications

**Digital Camera:** Information for your safety

<b>Power Source:</b>	DC 8.4 V
<b>Power Consumption:</b>	1.6 W (When recording with LCD Monitor) 1.6 W (When recording with Viewfinder) 0.7 W (When playing back with LCD Monitor) 0.7 W (When playing back with Viewfinder)

**Camera effective pixels:** 7,200,000 pixels  
**Image sensor:** 1/2.5" CCD, total pixel number 7,380,000 pixels  
 Primary color filter  
**Lens:** Optical 12× zoom, f=6 mm to 72 mm (35 mm film camera equivalent: 36 mm to 432 mm)/F2.8 to F3.3  
**Digital zoom:** Max. 4×  
**Extended optical zoom:** (Except for the maximum picture size for each aspect ratio) Max. 18×  
**Focus:** Normal/AF Macro/Manual focus, Multi-area-focusing/3-area-focusing (High speed)/1-area-focusing (High speed)/1-area-focusing/Spot-focusing  
**Focus range:** AF: 30 cm (0.98 feet) (Wide)/2 m (6.56 feet) (Tele) to ∞  
 AF Macro/MF/Simple: 5 cm (0.16 feet) (Wide)/2 m (6.56 feet) (Tele) to ∞ [However, the focus range is only in Tele.: 1 m (3.28 feet) (Tele) to ∞]  
**Shutter system:** Electronic shutter+Mechanical shutter  
**Motion picture recording:** When the aspect ratio setting is [4:3] 640×480 pixels (Only when using a card)/320×240 pixels  
 When the aspect ratio setting is [16:9] 848×480 pixels (Only when using a card) 30 or 10 frames/second with audio.  
**Burst recording**  
**Burst speed:** 3 pictures/second (High speed), 2 pictures/second (Low speed), Approx. 2 pictures/second (Unlimited)  
**Number of recordable pictures:** Max. 7 pictures (Standard), max. 5 pictures (Fine), Depends on the remaining capacity of the card (Unlimited). (Performance in burst recording is only with SD Memory Card. MultiMediaCard performance will be less.)  
**ISO sensitivity:** AUTO/100/200/400/800/1250 [HIGH SENS.] mode: 3200  
**Shutter speed:** 60 seconds to 1/2000th of a second [STARRY SKY] mode: 15 seconds, 30 seconds, 60 seconds  
 Motion picture mode: 1/30th of a second to 1/2000th of a second  
**White balance:** AUTO/Daylight/Cloudy/Shade/Flash/Halogen/White set1/White set2  
**Exposure (AE):** Program AE (P)/Aperture-priority AE (A)/ Shutter-priority AE (S)/Manual exposure (M) Exposure compensation (1/3 EV Step, -2 EV to +2 EV) Multiple/Center weighted/Spot  
**Metering mode:** 2.5" low-temperature polycrystalline TFT LCD (Approx. 207,000 pixels) (field of view ratio about 100%)  
**LCD monitor:** Color LCD Viewfinder (Approx. 188,000 pixels) (field of view ratio about 100%)  
**Viewfinder:** (with diopter adjustment -4 to +4 diopter)

**Flash:** Built-in pop up flash  
 Flash range: (ISO AUTO)  
 Approx. 30 cm (0.98 feet) to 6 m (19.7 feet) (Wide)  
 AUTO, AUTO/Red-eye reduction, Forced ON (Forced ON/Red-eye reduction), Slow sync./Red-eye reduction, Forced OFF  
**Microphone:** Monaural  
**Speaker:** Monaural  
**Recording media:** Built-in Memory (Approx. 27 MB)/SD Memory Card/SDHC Memory Card/MultiMediaCard (Still pictures only)  
**Picture size**  
**Still picture:** When the aspect ratio setting is [4:3] 3072×2304 pixels, 2560×1920 pixels, 2048×1536 pixels, 1600×1200 pixels, 1280×960 pixels, 640×480 pixels  
 When the aspect ratio setting is [3:2] 3072×2048 pixels, 2048×1360 pixels  
 When the aspect ratio setting is [16:9] 3072×1728 pixels, 1920×1080 pixels  
**Motion pictures:** When the aspect ratio setting is [4:3] 640×480 pixels (Only when using a card)/320×240 pixels  
 When the aspect ratio setting is [16:9] 848×480 pixels (Only when using a card)  
 Fine/Standard/RAW  
**Quality:**  
**Recording file format**  
**Still Picture:** JPEG (based on Design rule for Camera File system, based on Exif 2.21 standard)/RAW/DPOF corresponding  
**Picture with audio:** JPEG (based on Design rule for Camera File system, based on Exif 2.21 standard) QuickTime (picture with audio) QuickTime Motion JPEG (motion pictures with audio)  
**Motion pictures:** QuickTime Motion JPEG (motion pictures with audio)  
**Interface**  
**Digital:** USB 2.0 (Full Speed)  
**Analog video/audio:** NTSC/PAL Composite (Switched by menu), Audio line output (monaural)  
**Terminal**  
**DIGITAL/AV OUT:** Dedicated jack (8 pin)  
**DC IN:** Type 3 jack  
**Dimensions:** Approx. 112.5 mm (W)×72.2 mm (H)×79.0 mm (D) [4 7/16" (W)×2 13/16" (H)×3 1/8" (D)] (excluding the projecting parts)  
**Mass:** Approx. 310 g/10.9 oz (excluding card and battery), Approx. 357 g/12.6 oz (with card and battery)  
**Operating temperature:** 0 °C to 40 °C (32 °F to 104 °F)  
**Operating humidity:** 10% to 80%  
**Battery Charger (Panasonic DE-A43B):** Information for your safety

<b>Input:</b>	110 V to 240 V ~ 50/60 Hz, 0.15 A
<b>Output:</b>	CHARGE 8.4 V --- 0.43 A

**Equipment mobility:** Movable

**Battery Pack (lithium-ion) (Panasonic CGR-S006A):** Information for your safety

<b>Voltage/capacity:</b>	7.2 V, 710 mAh
--------------------------	----------------

# 5 Location of Controls and Components

## Names of the Components

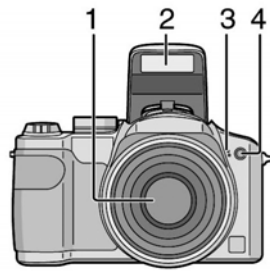

- 1 Lens
- 2 Flash
- 3 Microphone
- 4 Self-timer indicator  
AF assist lamp

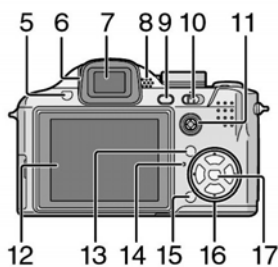

- 5 Flash open button
- 6 Diopter adjustment dial
- 7 Viewfinder
- 8 Speaker
- 9 [EVF/LCD] button
- 10 Camera ON/OFF switch
- 11 Joystick
- 12 LCD monitor
- 13 [DISPLAY/LCD MODE] button
- 14 Status indicator
- 15 Single or burst mode button/  
Delete button
- 16 Cursor buttons
  - ◀/Self-timer button
  - ▼/[REV] button
  - ▶/Flash Setting button
  - ▲/Exposure compensation/  
Auto bracket/Flash output  
adjustment/Backlight  
compensation in simple mode  
button
- 17 [MENU/SET] button

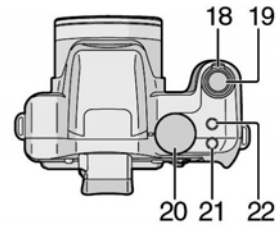

- 18 Zoom lever
- 19 Shutter button
- 20 Mode dial
- 21 Focus switch button
- 22 Optical image stabilizer button

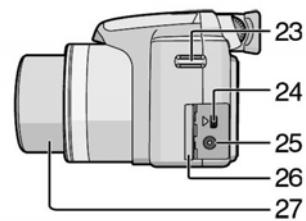

- 23 Strap eyelet
- 24 [DIGITAL/AV OUT] Socket
- 25 [DC IN] Socket
  - Always use a genuine Panasonic AC adaptor (DMW-AC7PP; optional).
  - The camera cannot charge the battery even if the AC adaptor (DMW-AC7PP; optional) is connected.
- 26 Terminal door
- 27 Lens Barrel

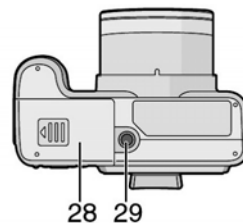

- 28 Card/Battery door
- 29 Tripod receptacle
  - When you use a tripod, make sure it is stable when the camera is attached to it.

## About The Mode Dial

If you turn on this unit and then rotate the mode dial, you can not only switch between recording and playback but also switch to a scene mode that matches your recording purpose.

### ■ Switching the mode by rotating the mode dial

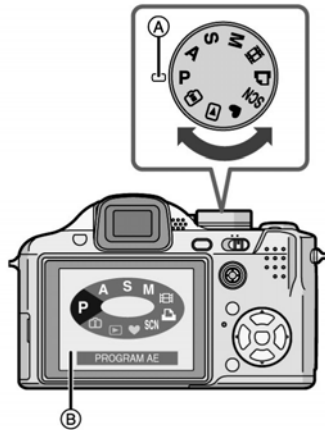

- **Adjust part (A) to the desired mode.**  
Rotate the mode dial slowly and surely to adjust to each mode. (The mode dial rotates 360 °)
- The above screen (B) appears on the LCD monitor/Viewfinder if the mode dial is rotated.
- The mode currently selected appears on the LCD monitor/Viewfinder when the camera is turned on.

### ■ Basic

#### **P** : Program AE mode

The exposure is automatically adjusted by the camera.

#### ♥ : Simple mode

This mode is recommended for beginners.

#### ▶ : Playback mode

This mode allows you to play back recorded pictures.

### ■ Advanced

#### 📷 : Intelligent ISO sensitivity mode

This allows you to set the optimal ISO sensitivity and shutter speed according to the movement and the brightness of the subject.

#### **A** : Aperture-priority AE mode

The shutter speed is automatically determined by the aperture value you set.

#### **S** : Shutter-priority AE mode

The aperture value is automatically determined by the shutter speed you set.

#### **M** : Manual exposure mode

The exposure is adjusted by the aperture value and the shutter speed which are manually adjusted.

#### **SCN** : Scene mode

This allows you to take pictures that match the scene being recorded.

#### 🎬 : Motion picture mode

This mode allows you to record motion pictures.

#### 🖨️ : Print mode

Use this to print pictures.

# 6 Service Mode

## 6.1. Error Code Memory Function

### 1. General description

This unit is equipped with history of error code memory function, and can be memorized 16 error codes in sequence from the latest. When the error is occurred more than 16, the oldest error is overwritten in sequence.

The error code is not memorized when the power supply is shut down forcibly (when the unit is powered on by the battery, the battery is pulled out) because the error code is memorized to FLASH ROM when the unit is powered off.

### 2. How to display

The error code can be displayed by the following procedure:

Before perform the error code memory function, connect the AC adaptor or insert the battery.

(Since this unit has built-in memory, this error code memory function can be performed without inserting SD memory card.)

- **1. The temporary cancellation of initial setting:**

Set the mode dial to “[ P ]”.

While keep pressing [ Optical Image Stabilizer Button ] and “[ UP ] of Cross key” simultaneously, turn the Power on.

- **2. The display of error code:**

Press [ Optical Image Stabilizer Button ], [ MENU ] and “[ LEFT ] of Cross key” simultaneously with the step 1 condition.

The display is changed as shown below when the above buttons is pressed simultaneously.

Normal display → Error code display → Operation history display → Normal display → .....

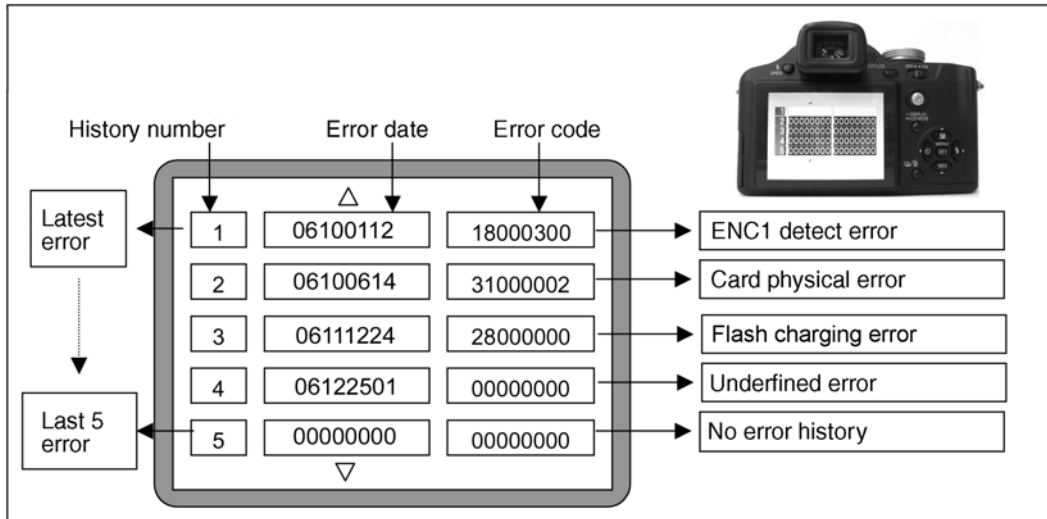

Example of Error Code Display

- **3. The change of display:**

The error code can be memorized 16 error codes in sequence, however it is displayed 5 errors on the LCD.

Display can be changed by the following procedure:

“[ UP ] or [ DOWN ] of Cross key” : It can be scroll up or down one.

“[ LEFT ] or [ RIGHT ] of Cross key” : It can be display last 5 error or another 5 error.

- **4. How to read the error date:**

The error date code is displayed from the left in order at the year, month, day, time.

Error date information is acquired from "Clock setting" information when the error occurs. When the clock is not setting, it is displayed as "00000000".

- **5. How to read the error code:**

One error code is displayed for 8 bit, the contents of error codes is indicated the table as shown below.

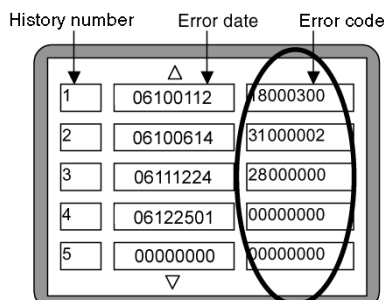

Attribute	Main item	Sub item	Error code		Contents (Upper)	
			High 4 bits	Low 4 bits	Check point (Lower)	
LENS	Lens drive	OIS	18*0	1000	PSD (X) error. Hall element (X axis) position detect error in OIS unit. OIS Unit	
				2000	PSD (Y) error. Hall element (Y axis) position detect error in OIS unit. OIS Unit	
				3000	GYRO (X) error. Gyro (IC7101: X axis) detect error on Main P.C.B.. IC7101 (Gyro element) or IC6001 (VENUS 3)	
				4000	GYRO (Y) error. Gyro (IC7102: Y axis) detect error on Main P.C.B.. IC7102 (Gyro element) or IC6001 (VENUS 3)	
				5000	MREF error (Reference voltage error). IC7001 (LENS drive) or IC6001 (VENUS 3)	
				6000	Drive voltage (X) error. VENUS 3 AD value error, LENS Unit, LENS flex breaks etc.	
				7000	Drive voltage (Y) error. VENUS 3 AD value error, LENS Unit, LENS flex breaks etc.	
				C.B./Zoom	0100	HP Low detect error (C.B. encoder (full retract) always Low detect). FP9005-(36,39) signal line or IC6001 (VENUS 3)
					0200	HP High detect error (C.B. encoder (full retract) always High detect). FP9005-(37,40) signal line or IC6001 (VENUS 3)
					0300	ENC1 detect error (C.B. motor encoder detect error). FP9005-(36) signal line or IC6001 (VENUS 3)
					0400	ENC2 detect error (C.B. motor encoder detect error). FP9005-(39) signal line or IC6001 (VENUS 3)
				Zoom	0010	HP Low detect error (Zoom encoder always Low detect error).
					0020	HP High detect error (Zoom encoder always High detect error).
					0030	ENC1 detect error (Zoom encoder detect error).
		0040	ENC2 detect error (Zoom encoder detect error).			
		Focus	0001	HP Low detect error (Focus encoder always Low detect error). FP9005-(17) signal line or IC6001 (VENUS 3)		
			0002	HP High detect error (Focus encoder always High detect error). FP9005-(17) signal line or IC6001 (VENUS 3)		
		Lens	10*3	0000	Lens cap error. Zoom motor, zoom pulse encoder2	
				0000	Lens cap error (completing initialization). Zoom motor, zoom pulse encoder2	
			18*1	0000	Power ON time out error. Lens drive system	
				0000	Power OFF time out error. Lens drive system	
		Adj.History	OIS	19*0	2000	OIS adj. Yaw direction amplitude error (small)
					3000	OIS adj. Pitch direction amplitude error (small)
					4000	OIS adj. Yaw direction amplitude error (large)
					5000	OIS adj. Pitch direction amplitude error (large)
					6000	OIS adj. MREF error
					7000	OIS adj. time out error
					8000	OIS adj. Yaw direction off set error
	9000				OIS adj. Pitch direction off set error	
	A000				OIS adj. Yaw direction gain error	
	B000				OIS adj. Pitch direction gain error	
	C000				OIS adj. Yaw direction position sensor error	
	D000				OIS adj. Pitch direction position sensor error	
E000	OIS adj. other error					
HARD	VENUS A/D				Flash	28*0
	FLASH ROM (EEPROM Area)	FLASH ROM (EEPROM Area)	2B*0	0001	EEPROM read error IC6002 (FLASH ROM)	
				0002	EEPROM write error IC6002 (FLASH ROM)	
	SYSTEM	RTC	2C*0	0001	SYSTEM IC initialize failure error Communication between IC6001 (VENUS 3) and IC9101 (SYSTEM)	



Attribute	Main item	Sub item	Error code		Contents (Upper)	
			High 4 bits	Low 4 bits	Check point (Lower)	
SOFT	CPU	Reset	30*0	0001	NMI reset	
				0007	Non Mask-able Interrupt (30000001-30000007 are caused by factors)	
	Card	Card	31*0	0001	Card logic error SD memory card data line or IC6001 (VENUS 3)	
				0002	Card physical error SD memory card data line or IC6001 (VENUS 3)	
				0004	Write error SD memory card data line or IC6001 (VENUS 3)	
				39*0	0005	Format error
				CPU, ASIC hard	Stop	38*0
	0002	Camera task invalid code error. IC6001 (VENUS 3)				
	0100	File time out error in recording motion image IC6001 (VENUS 3)				
	0200	File data send error in recording motion image IC6001 (VENUS 3)				
	0300	Single or burst recording brake time out.				
	Operation	Power on	3B*0	0000	FLASHROM processing early period of camera during movement.	
	Zoom	Zoom	3C*0	0000	Inperfect zoom lens processing. Zoom lens	
				0001	Software error. (0-7bit : command, 8-15bit : status)	
				0007		
				35*1	0000	Though record preprocessing is necessary, it is not called.
			35*2	0000	Though record preprocessing is necessary, it is not completed.	

**About "\*" indication in the above table:**

The third digit from the left is different as follows.

- In case of 0 (example: 18001000)

When the third digit from the left shows "0", this error occurred under the condition of INITIAL SETTINGS has been completed.

It means that this error is occurred basically at user side.

- In case of 8 (example: 18801000)

When the third digit from the left shows "8", this error occurred under the condition of INITIAL SETTINGS has been released.

(Example; Factory assembling-line before unit shipment, Service mode etc.)

It means that this error is occurred at service side.

**• 6. How to returned to Normal Display:**

Turn the power off and on, to exit from Error code display mode.

**NOTE:**

The error code can not be initialized.

## 6.2. Confirmation of Firmware Version

The Firmware version can be confirmed by ordering the following steps:

- **Step 1. The temporary cancellation of initial setting:**

Set the mode dial to “[ P ]”.

Insert the SD memory card which has a few photo data.

While keep pressing [ Optical Image Stabilizer ] and “[ UP ] of Cross key” simultaneously, then turn the power on.

- **Step 2. Confirm the version:**

Set the mode dial to “[ Playback ]” and then press [ DISPLAY ] to switch to LCD with indication. (Fig. A)

Press [ Optical Image Stabilizer ] and “[ DOWN ] of Cross key” simultaneously. (No need to keep pressing.)

(The version information is displayed on the LCD with light blue colour letters.) (Fig. B)

**CAUTION:**

The version information does not display if the LCD has switched to LCD with indication already.

In this case, press [ DISPLAY ] to switch to LCD with indication.

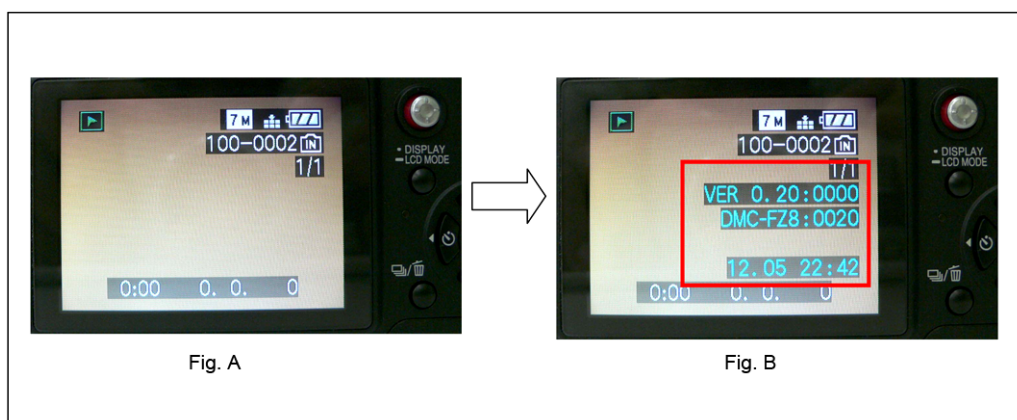
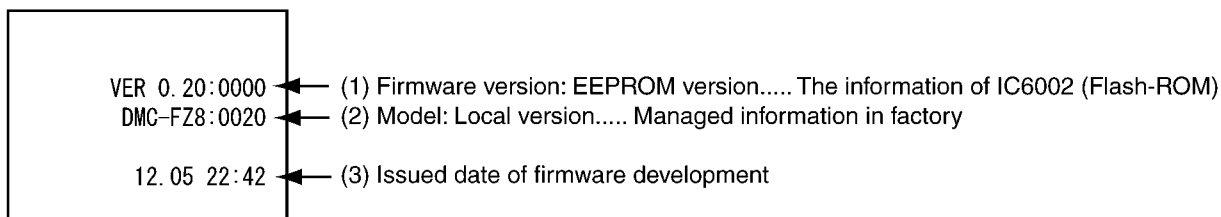





**<Point>**

- The firmware version and EEPROM version can be confirmed with the information (1).
- The information (2), (3) are just reference.

## 7 Service Fixture & Tools

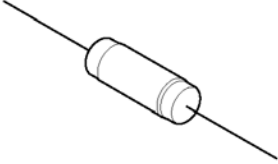
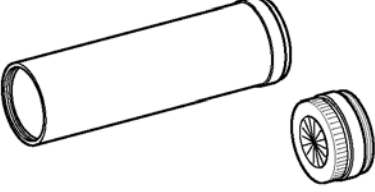
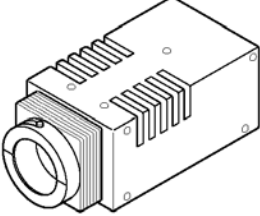
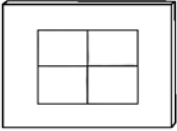
### 7.1. Service Fixture and Tools

The following Service Fixture and tools are used for checking and servicing this unit.

<b>Resistor for Discharging</b> <b>ERG5SJ102</b>	<b>Infinity Lens (with Focus Chart)</b> <b>VFK1164TCM02</b>	<b>LIGHT BOX</b> <b>VFK1164TDVLB</b>
 <b>An equivalent type of Resistor may be used.</b>		 <b>※ with DC Cable</b>
<b>TR Chart</b> <b>RFKZ0434</b>	<b>Lens Cleaning Kit (BK)</b> <b>VFK1900BK</b>	<b>Grease (for lens)</b> <b>VFK1829</b>
	 <b>* Only supplied as 10 set/box.</b>	
<b>Furoyl grease (for focus motor)</b> <b>VFK1850</b>		
		

## 7.2. When Replacing the Main PCB

After replacing the MAIN PCB, be sure to achieve adjustment.

The adjustment instruction is available at "software download" on the "Support Information from NWBG/VDBG-PAVC" web-site in "TSN system", together with Maintenance software.

## 7.3. Service Position

This Service Position is used for checking and replacing parts. Use the following Extension cables for servicing.

Table S1 Extension Cable List

No.	Parts No.	Connection	Form
1	RFKZ0361	FP9001 (MAIN) - CCD UNIT	28PIN 0.5 FFC
2	RFKZ0389	FP9002 (MAIN) - TOP OPERATION UNIT	11PIN 0.5 FFC
3	RFKZ0363	FP9003 (MAIN) - LCD UNIT	19PIN 0.5 FFC
4	VFK1443	FP9004 (MAIN) - EVF UNIT	18PIN 0.5 FFC
5	VFK1953	FP9005 (MAIN) - LENS FPC UNIT	40PIN 0.5 FFC
6	VFK1974	FP9006 (MAIN) - LCD UNIT	4PIN 0.5 FFC
7	VFK1576DSC04	P9001 (MAIN) - SPEAKER	2PIN CABLE
8	RFKZ0359	P9003 (MAIN) - FLASH UNIT	2PIN CABLE
9	VFK1576DC202	P9004 (MAIN) - FLASH UNIT	2PIN CABLE
10	VFK1576DC202	P9005 (MAIN) - FLASH UNIT	2PIN CABLE
11	RFKZ0360	P9006 (MAIN) - P9301 (AF LED/MIC)	5PIN CABLE
12	VFK1480	FP9007 (MAIN) - EVF UNIT	6PIN 0.5 FFC

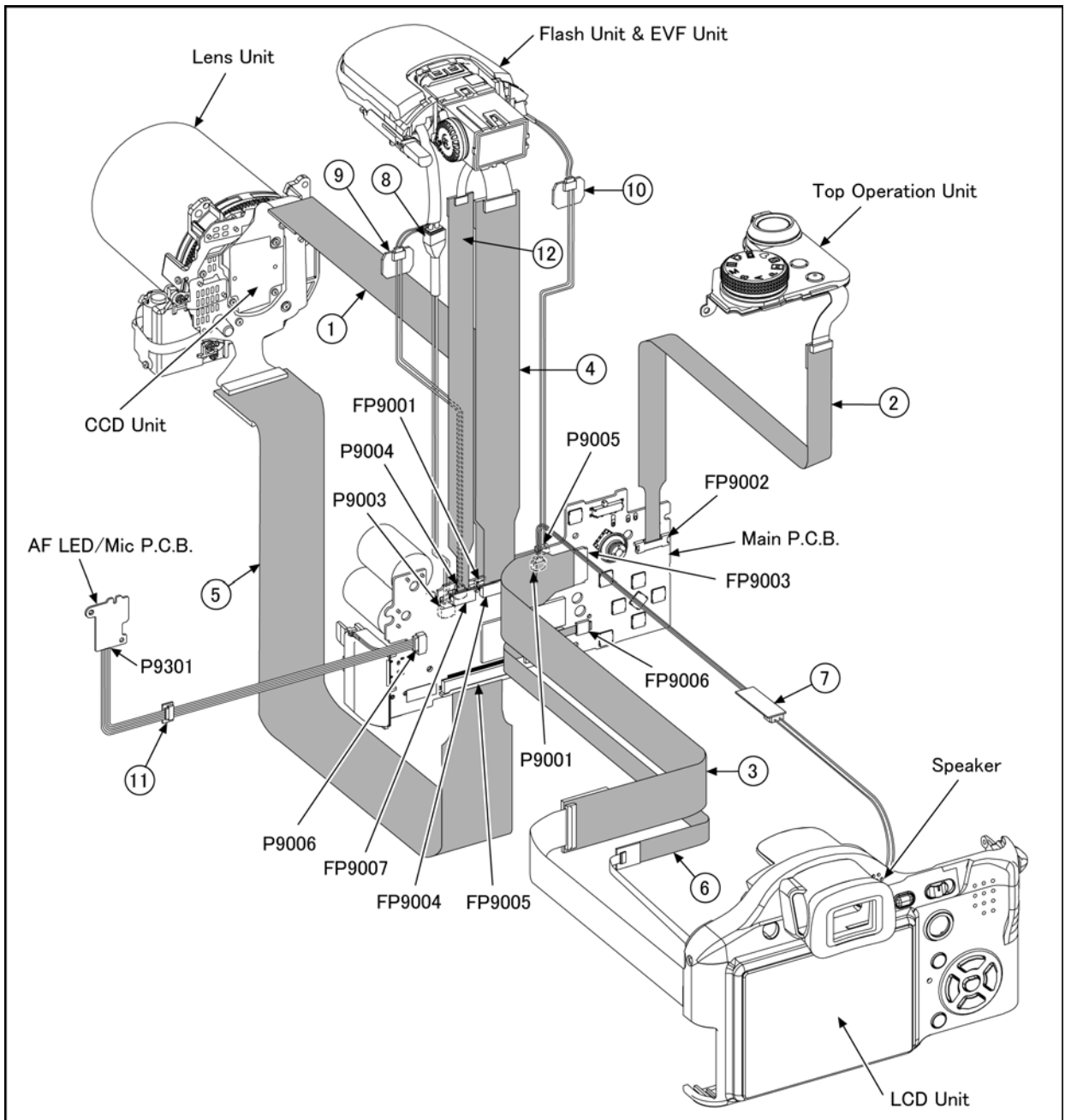

**CAUTION-1. (When servicing MAIN PCB)**

1. Be sure to discharge the capacitor on MAIN PCB.  
Refer to "HOW TO DISCHARGE THE CAPACITOR ON MAIN PCB".  
The capacitor voltage is not lowered soon even if the AC Cord is unplugged or the battery is removed.
2. Be careful of the high voltage circuit on MAIN PCB.
3. DO NOT allow other parts to touch the high voltage circuit on MAIN PCB.

# 8 Disassembly and Assembly Instructions

## 8.1. Disassembly Flow Chart

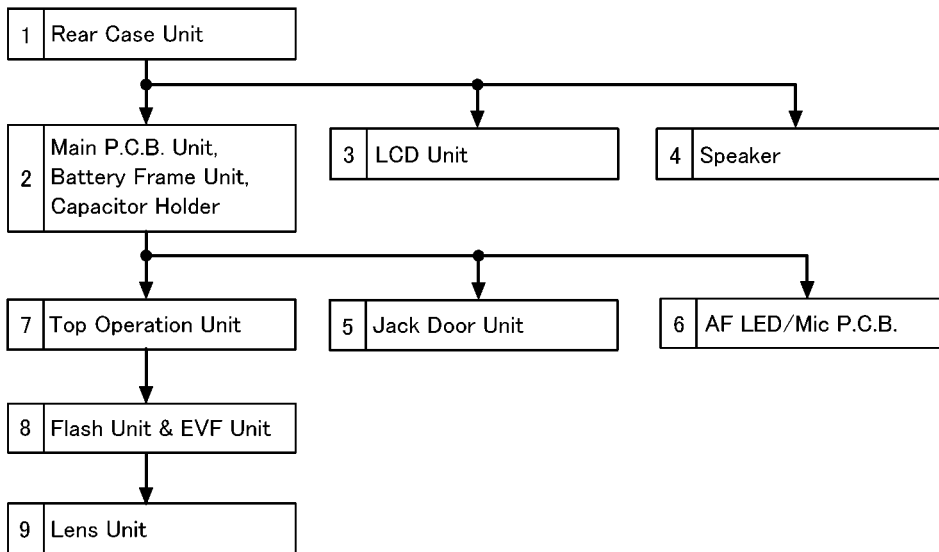

## 8.2. PCB Location

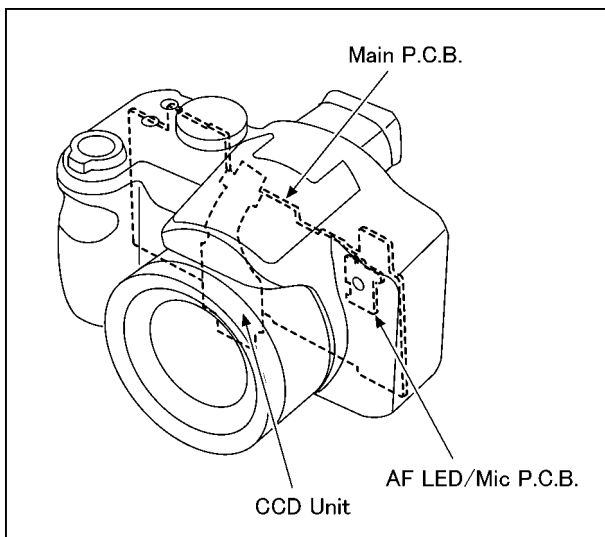

### 8.3. Disassembly Procedure

No.	Item	Fig	Removal
1	Rear Case Unit	Fig. D1	Card
			Battery
			4 Screws (A) 2 Screws (B)
		Fig. D2	P9001(Connector)
			FP9003(Flex)
			FP9006(Flex)
Rear Case Unit			
2	Main P.C.B. Unit Battery Frame Unit Capacitor Holder	Fig. D3	2 Screws (C)
			1 Screw (D)
			FP9001(Flex)
			FP9002(Flex)
			FP9004(Flex)
			FP9005(Flex)
			FP9007(Flex)
			P9003(Connector)
			P9004(Connector)
			P9005(Connector)
			Main P.C.B. Unit
			Fig. D4
		4 Locking tabs	
		P9006(Connector)	
		Battery Frame Unit	
Capacitor Holder			
3	LCD Unit	Fig. D5	1 Screw (F)
			2 Locking tabs
			LCD Holder
			LCD Unit
4	Speaker	Fig. D6	2 Screws (G)
			Plate
			Speaker
5	Jack Door Unit	Fig. D7	1 Screw (H)
			Jack Door Unit
6	AF LED/Mic P.C.B.	Fig. D8	2 Locking tabs
			AF LED P.C.B. Holder
			AF LED/Mic P.C.B.
7	Top Operation Unit	Fig. D9	Top Operation Unit
8	Flash Unit & EVF Unit	Fig. D10	Flash Unit & EVF Unit
9	Lens Unit	Fig. D11	1 Screw (J)
			Lens Unit

### 8.3.1. Removal of the Rear Case Unit

**NOTE:**

When servicing and reassembling, remove the card and battery from the unit.

- Card
- Battery
- Screw (A) × 4
- Screw (B) × 2

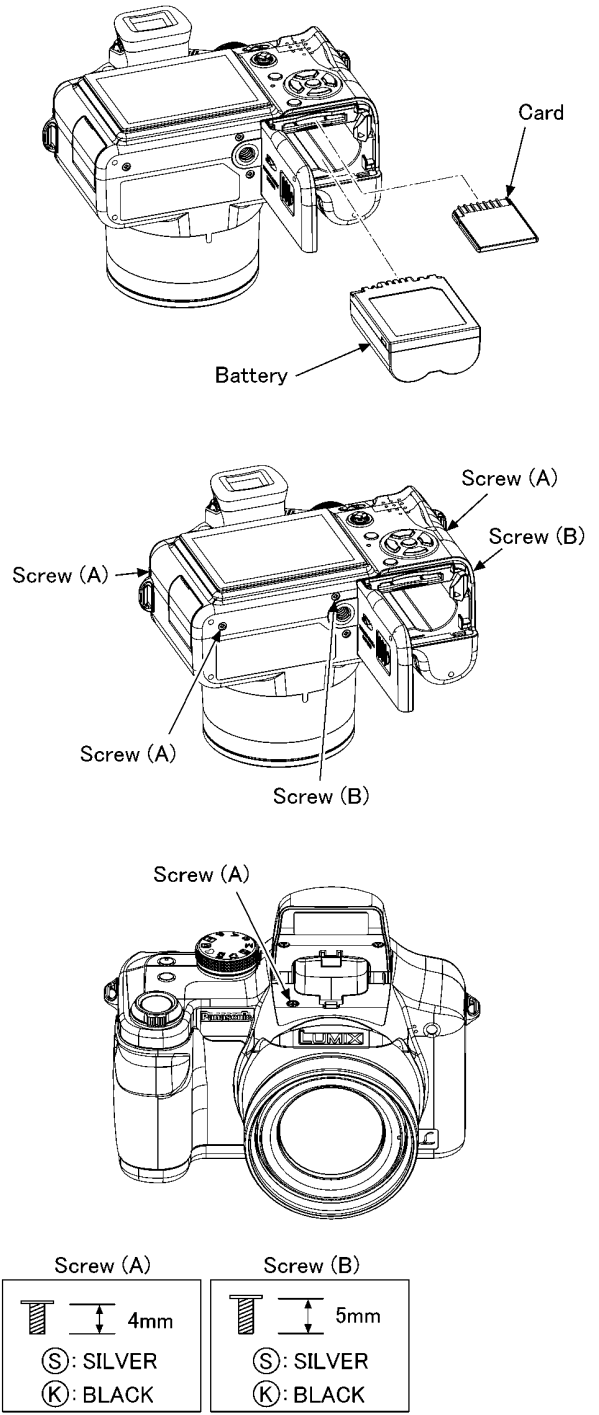
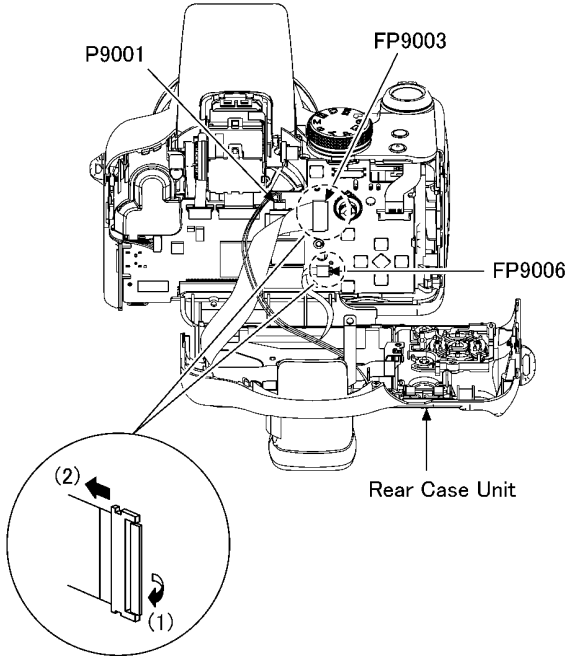

Fig. D1

- P9001 (Connector)    •FP9006 (Flex)
- FP9003 (Flex)

**NOTE: (When Replacing)**

- Take care not to damage the flex.
- When remove the flex, pull up the locking tab in the direction of arrow (1), and then remove the flex in the direction of arrow (2).



**NOTE: (When Installing)**

Align the projection of power switch and the groove of power knob.

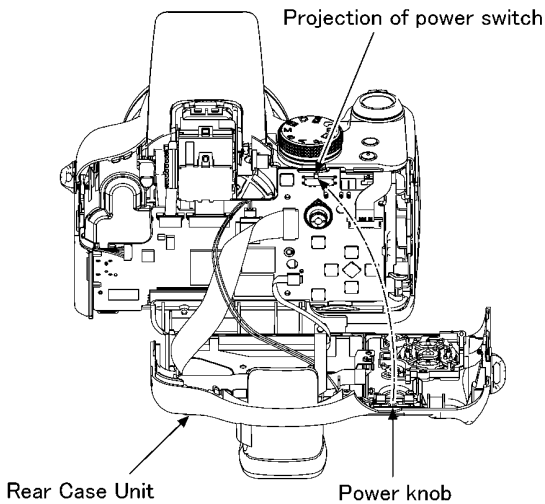

Fig. D2

### 8.3.2. Removal of the Main P.C.B. Unit, Battery Frame Unit and Capacitor Holder

- Screw (C) × 2    •FP9005 (Flex)
- Screw (D) × 1    •FP9007 (Flex)
- FP9001 (Flex)    •P9003 (Connector)
- FP9002 (Flex)    •P9004 (Connector)
- FP9004 (Flex)    •P9005 (Connector)

**NOTE: (When Replacing)**

When replace the connector (FP9004, FP9007), Take care not to damage the flex.

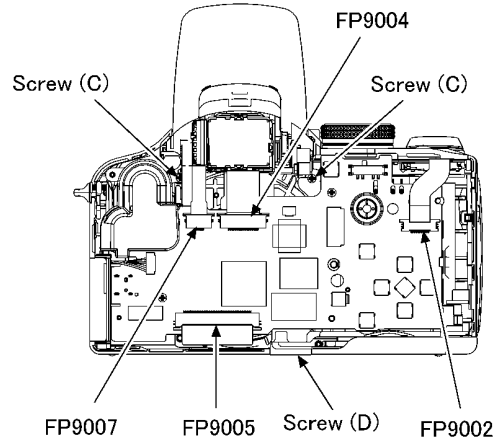

**NOTE: (When Replacing)**

- Take care not to damage the flex.
- When remove the flex, pull up the locking tab in the direction of arrow (1), and then remove the flex in the direction of arrow (2).

Main P.C.B. Unit

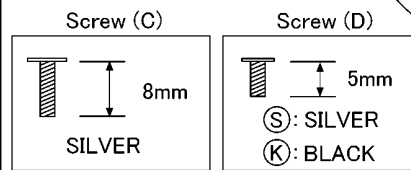
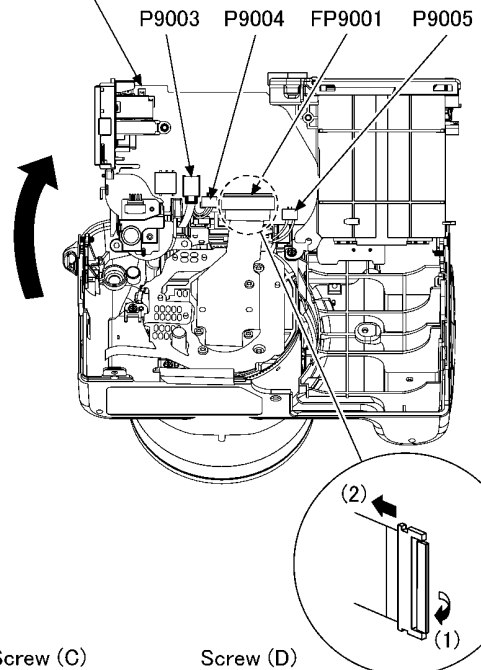

Fig. D3



- This unit equipped with two pieces of capacitors as flash charging capacitors.  
"Either one of the capacitor discharging operation" makes discharging for others as well.

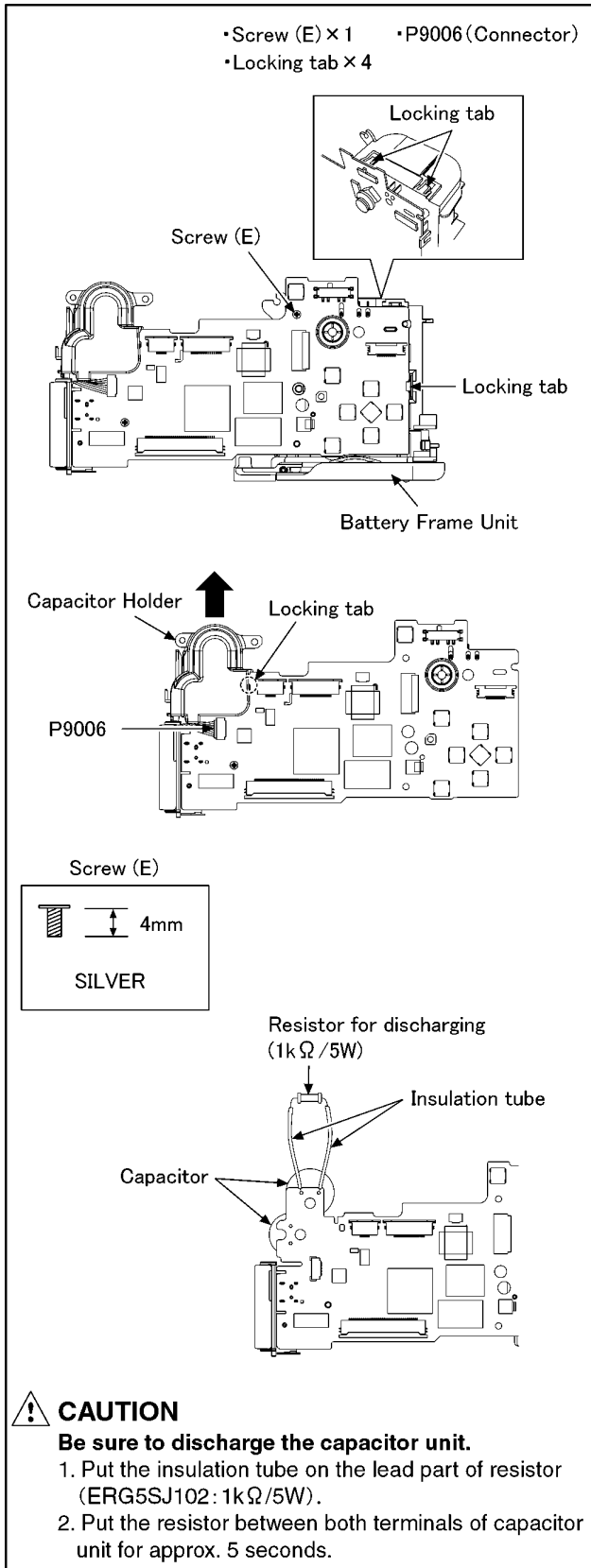

Fig. D4

### 8.3.3. Removal of the LCD Unit

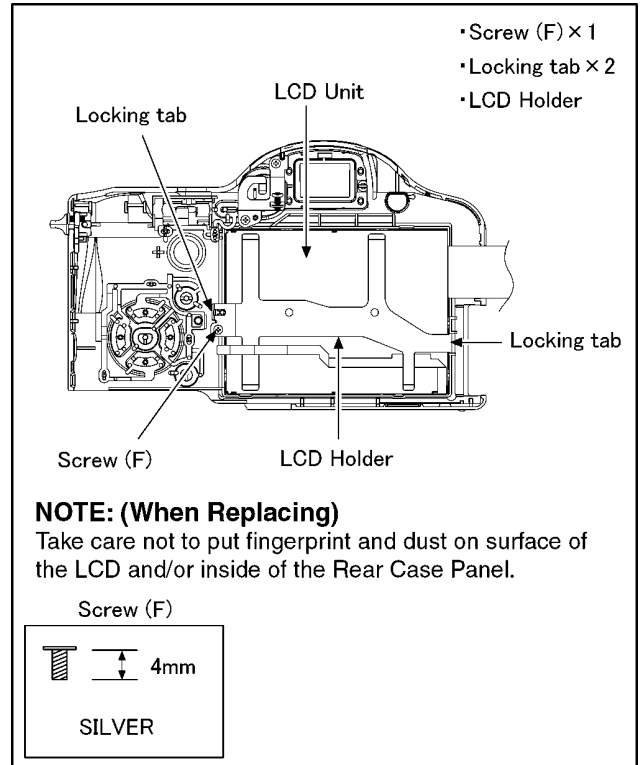

Fig. D5

### 8.3.4. Removal of the Speaker

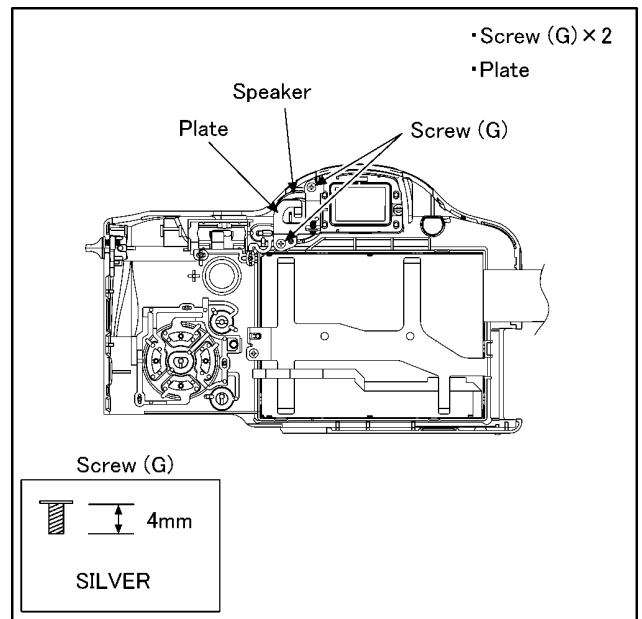

Fig. D6

### 8.3.5. Removal of the Jack Door Unit

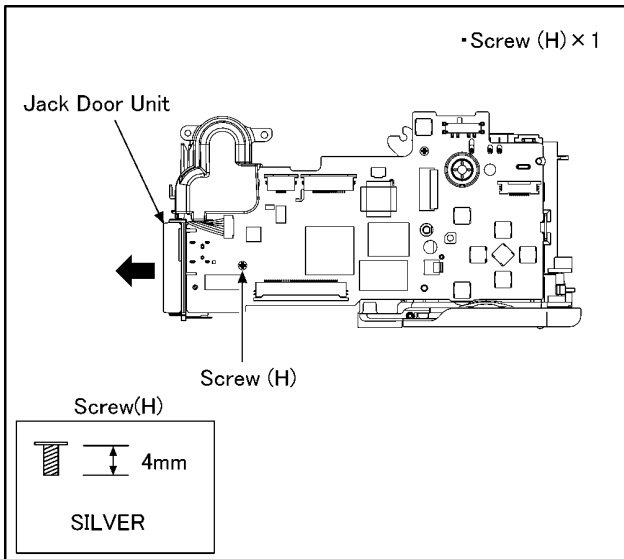

Fig. D7

### 8.3.8. Removal of the Flash Unit & EVF Unit

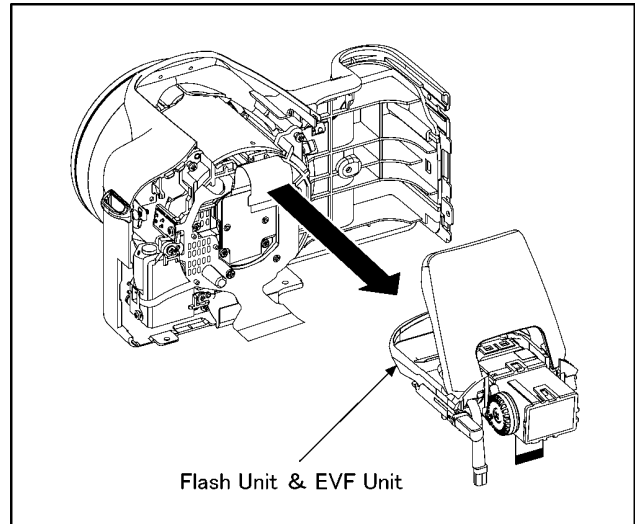

Fig. D10

### 8.3.6. Removal of the AF LED/Mic P.C.B.

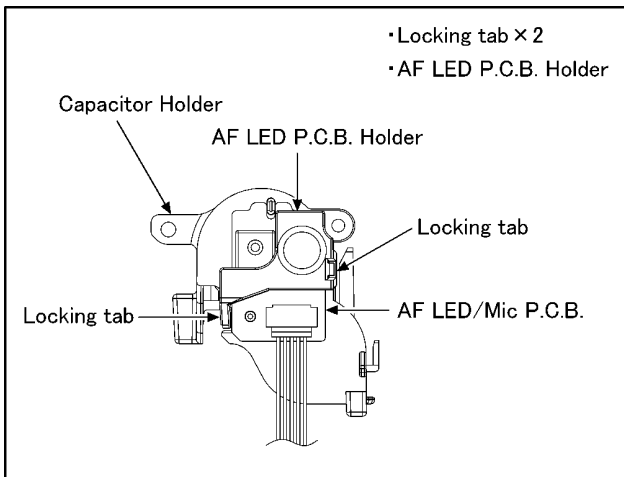

Fig. D8

### 8.3.9. Removal of the Lens Unit

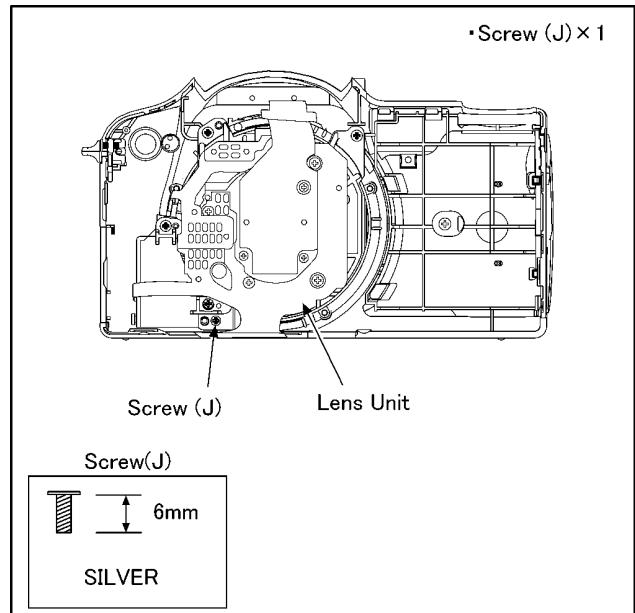

Fig. D11

### 8.3.7. Removal of the Top Operation Unit

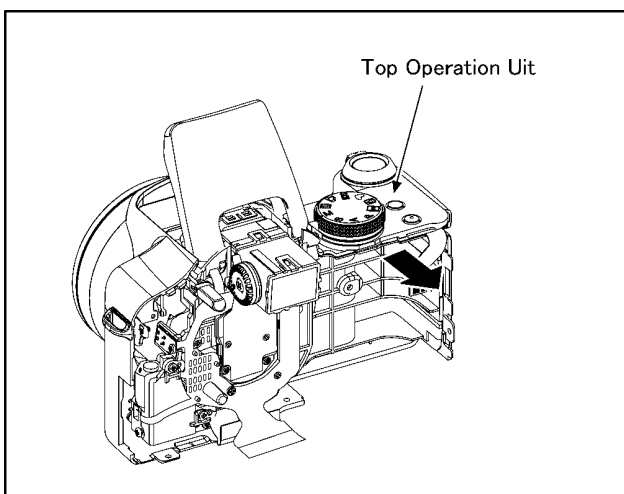

Fig. D9

#### NOTE: (When Assembling)

- Be sure to confirm the following points when assembling.
- The Screw is tightened enough.
  - Assembling conditions are fine. (No distortion, no illegal-space.)
  - No dust and/or dirt on every Lens surfaces.
  - LCD image is fine. (No dust and dirt on it, and no gradient images.)

## 8.4. Disassembly/Assembly Procedure for the Lens

### NOTE: When Disassembling and Assembling for the Lens

- To minimize the possibility of the CCD being dirt, perform disassemble and/or assemble under the condition of the CCD is being mounted.  
Disassembling procedures for the CCD unit, refer to item 8.5.
- Take care that the dust and dirt are not entered into the lens.  
In case of the dust is putted on the lens, blow off them by airbrush.
- Do not touch the surface of lens.
- Use lens cleaning KIT (BK)(VFK1900BK).
- Apply the grease (VFK1829) to the point where is shown to "Grease apply" in the figure.  
When the grease is applied, use a toothpick and apply thinly.

### 8.4.1. Removal of the Zoom Motor Unit

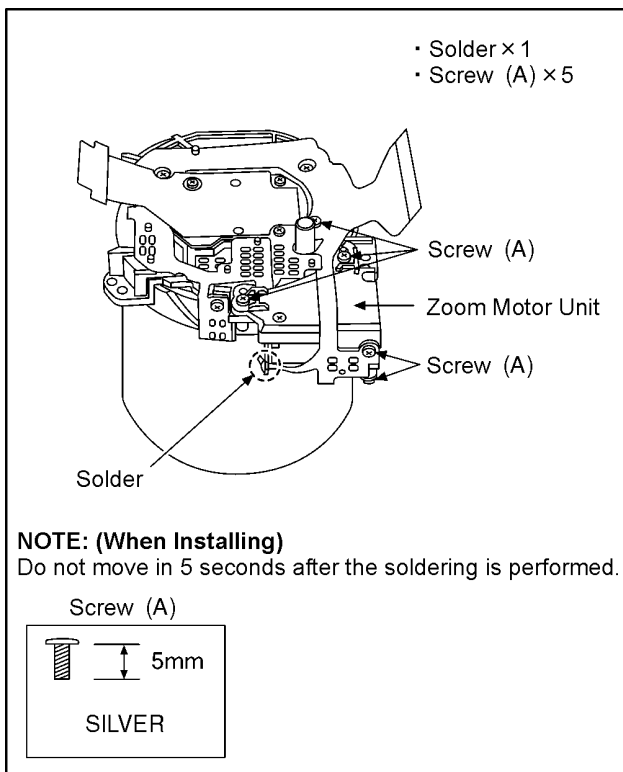

## 8.4.2. Removal of the 3rd Lens Frame/ 4th Lens Frame/Drive Frame Unit

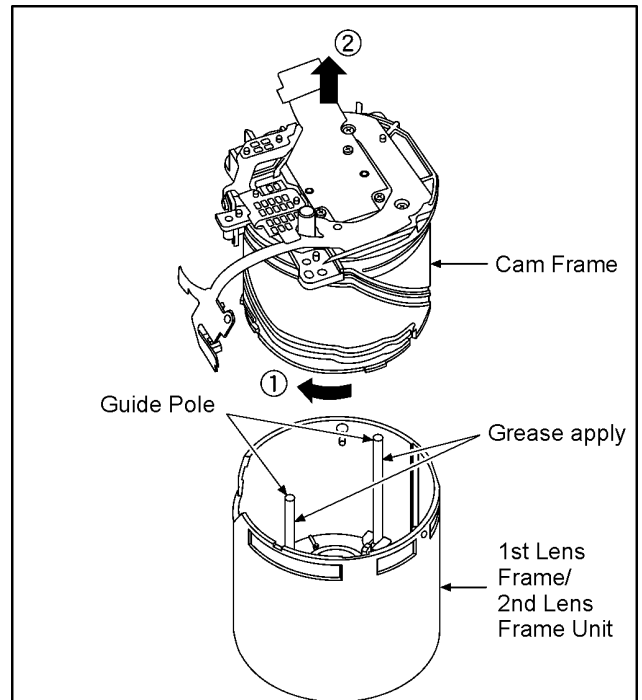

### NOTE: (When Removing)

Remove the 1st /2nd lens frame unit by rotating the Cam Frame in arrow directions.  
Removal order: ①→②.  
When the Cam Frame is hard to rotate, use the tweezers and rotate round gear of the Cam Frame.

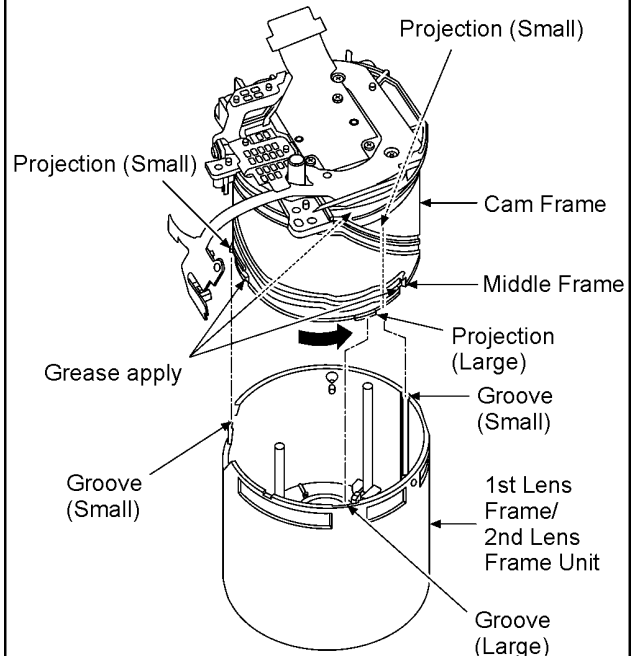

### NOTE: (When Installing)

- Align the cut of middle frame and the groove of cam frame.
- Apply grease to 2 guide poles.
- Align the groove of 1st lens frame unit and the projection of middle frame, and then turn the cam frame counterclockwise fully to make retract position.

### 8.4.3. Removal of the Master Flange Unit

- Screw (B) × 3
- Lock × 6
- Solder × 2
- Locking tab × 1

**NOTE: (When Removing)**

When remove the master flange, take care not to damage the OIS, Shutter and Focus motor flex.

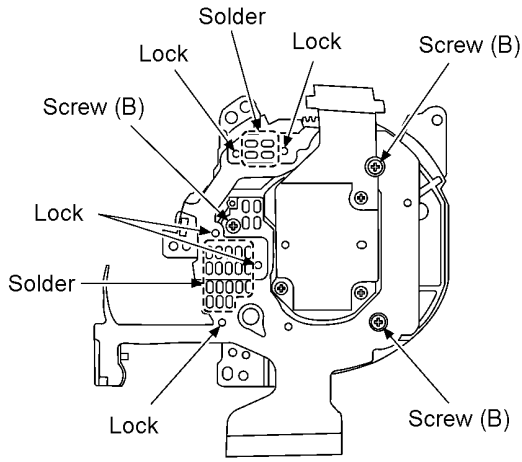

Master Flange Unit

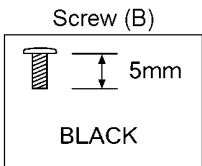
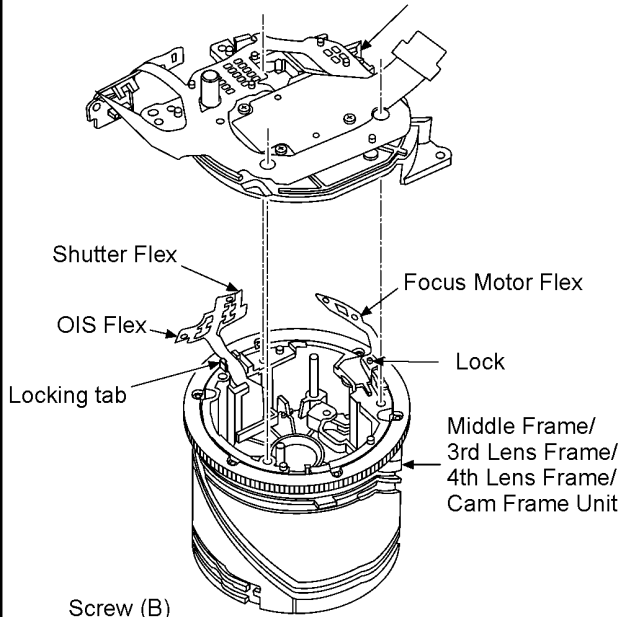

**NOTE: (When Installing)**

1. Latch the OIS and shutter flex to the locking tab and fix focus motor flex on the lock.
2. Screw 3 screws (B).
3. Fix 5 locks on master flange unit.
4. Soldered.

※Do not move in 5 seconds after the soldering is performed.  
 ※Take care not to cut the OIS, shutter and focus motor flex.

### 8.4.4. Removal of the Cam Frame

**NOTE: (When Removing)**

When remove the cam frame, take care not to damage the OIS, Shutter and Focus motor flex.

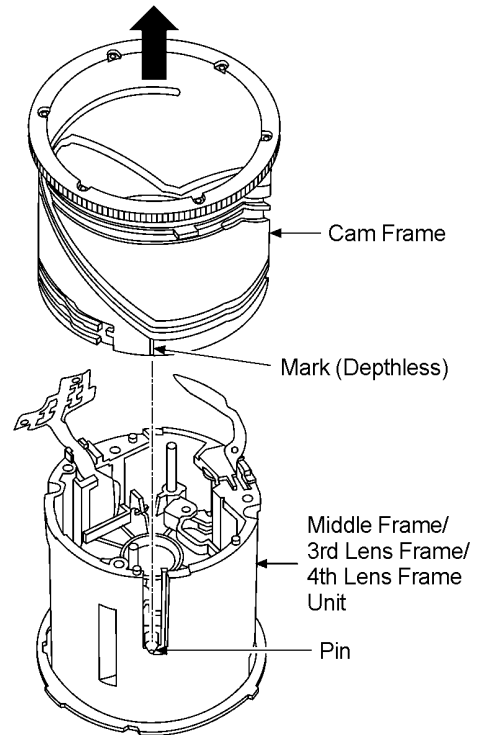

**NOTE: (When Installing)**

Align the pin of 3rd lens frame unit and mark (depthless) of cam frame, and then install.

### 8.4.5. Removal of the Focus Motor Unit

- Screw (C) × 2
- Lock × 4

**NOTE: (When Removing)**

When remove the focus motor, take care not to damage the Focus motor flex.

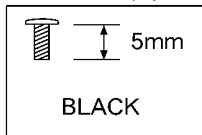
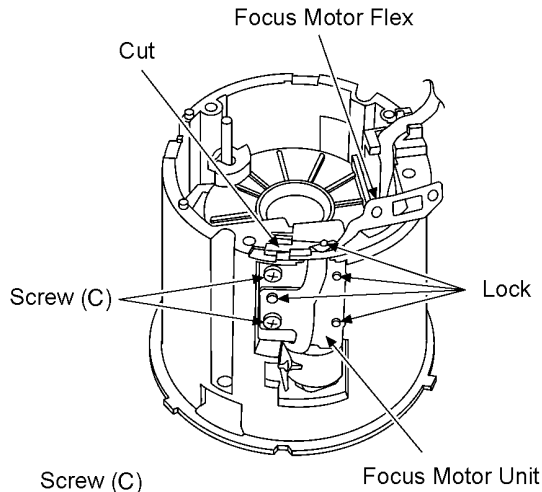

**NOTE: (When Installing)**

1. Insert the focus motor flex to the cut of middle frame, and then install focus motor unit.
2. Confirm the rack of 4th lens frame unit is engaged with screw shaft of focus motor.

Screw shaft  
Grease apply

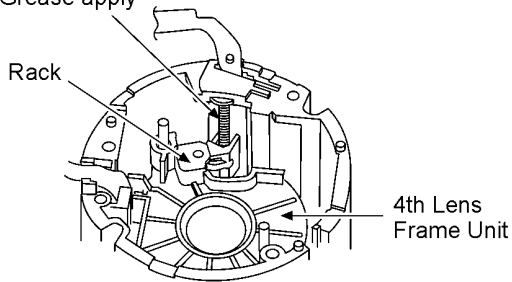

### 8.4.6. Removal of the 4th Lens Frame Unit

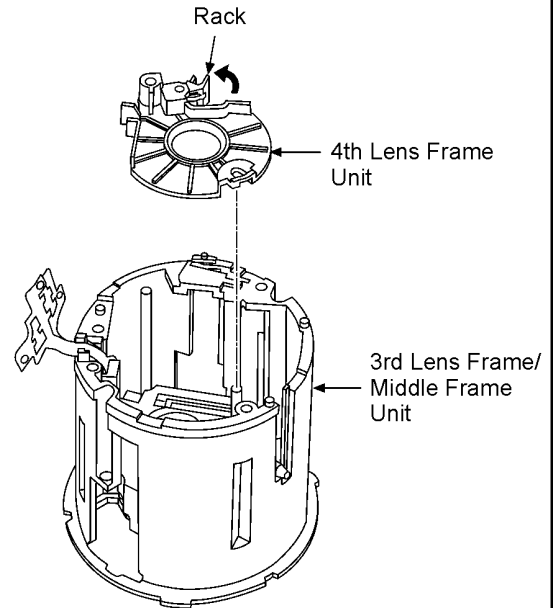

**NOTE: (When Installing)**

Turn the rack of 4th lens frame unit to the indication by arrow fully.

### 8.4.7. Removal of the 3rd Lens Frame Unit

**NOTE: (When Removing)**

When remove the 3rd lens frame unit, take care not to damage the OIS and Shutter flex.

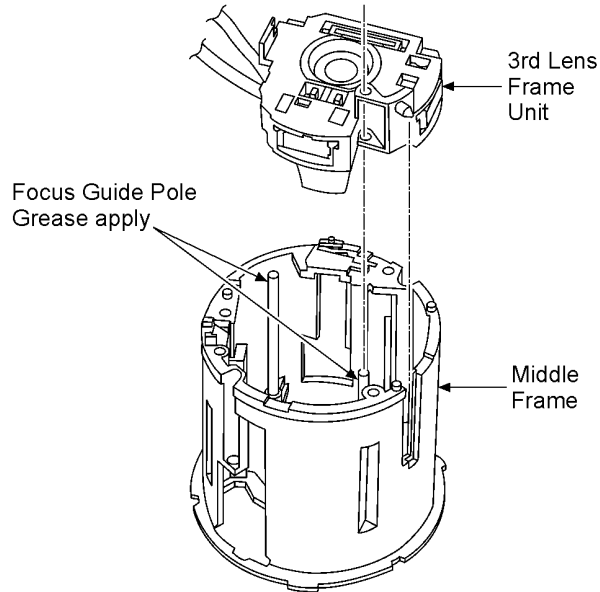

**NOTE: (When Installing)**

Install 2 focus guide poles to the middle frame.  
Fix the OIS and shutter flex to the latch of middle frame.  
(Installing order: Shutter flex → OIS flex)

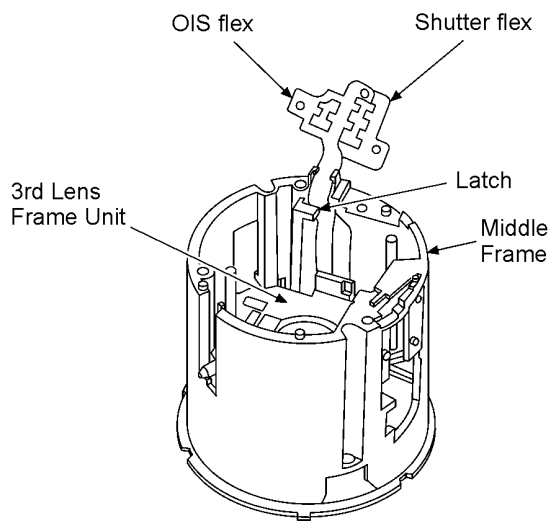

### 8.4.8. Removal of the 2nd Lens Frame Unit

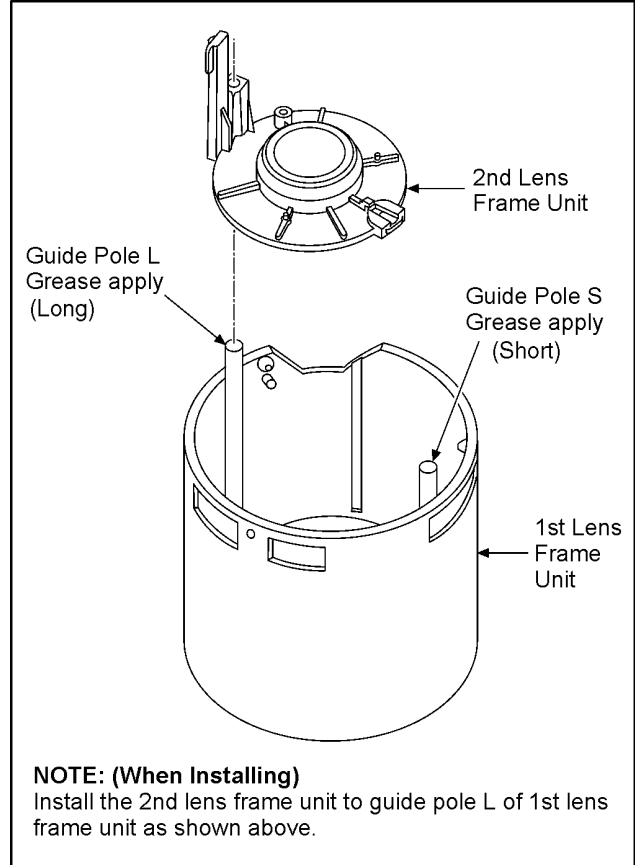

**NOTE: (When Installing)**

Install the 2nd lens frame unit to guide pole L of 1st lens frame unit as shown above.

## 8.5. Removal of the CCD Unit

To prevent the CCD unit from catching the dust and dirt, do not remove the CCD unit except for replacing.

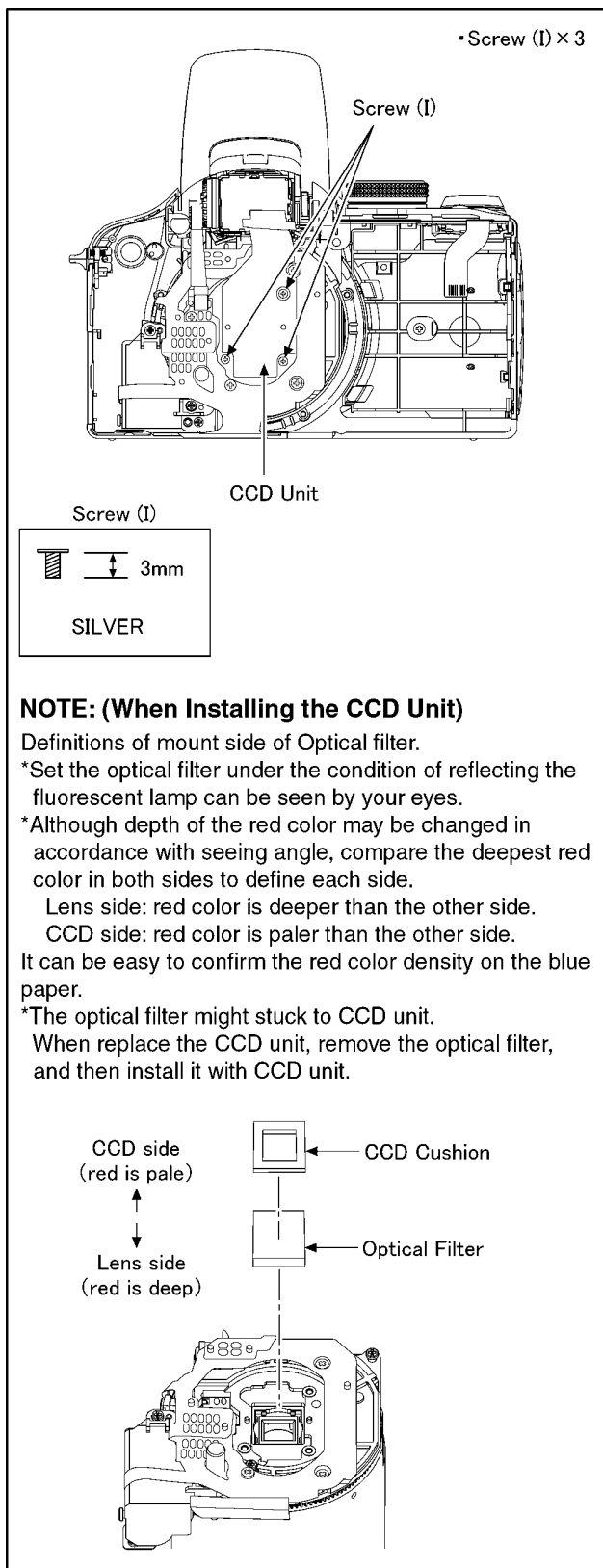

# 9 Measurements and Adjustments

## 9.1. Matrix Chart for Replaced Part and Necessary Adjustment

The relation between Replaced part and Necessary Adjustment is shown in the following table.

When concerned part is replaced, be sure to achieve the necessary adjustment(s).

As for Adjustment condition/procedure, consult the "Adjustment Manual" which is available in Adjustment software.

The Adjustment software is available at "TSN Website", therefore, access to "TSN Website" at "Support Information from NWBG/VDBG-PAVC".

**NOTE:**

After adjustments have been terminated, make sure to achieve "INITIAL SETTINGS".

Adjustment Item		Replaced Part					
		Main P.C.B.	VENUS (IC6001)	Flash-ROM (IC6002)	Lens Part (Excluding CCD)	CCD Unit	EVF
Camera Section	OIS hall element adjustment (OIS)	○	○	○	○		
	Back focus adjustment (BF)	○	○	○	○		
	Shutter adjustment (SHT)	○	○	○	○	○	
	ISO sensitivity adjustment (ISO)	○	○	○	○	○	
	AWB adjustment High brightness coloration inspection (WBL)	○	○	○	○	○	
	CCD white scratch compensation (WKI)	○	○	○		○	
EVF Section	EVF Rank Setting (EVF)	○		○			○

**NOTE:**

\*There is no LCD adjustment in this model.

\*There is no CCD Black scratch compensation adjustment (BKI) in this model.

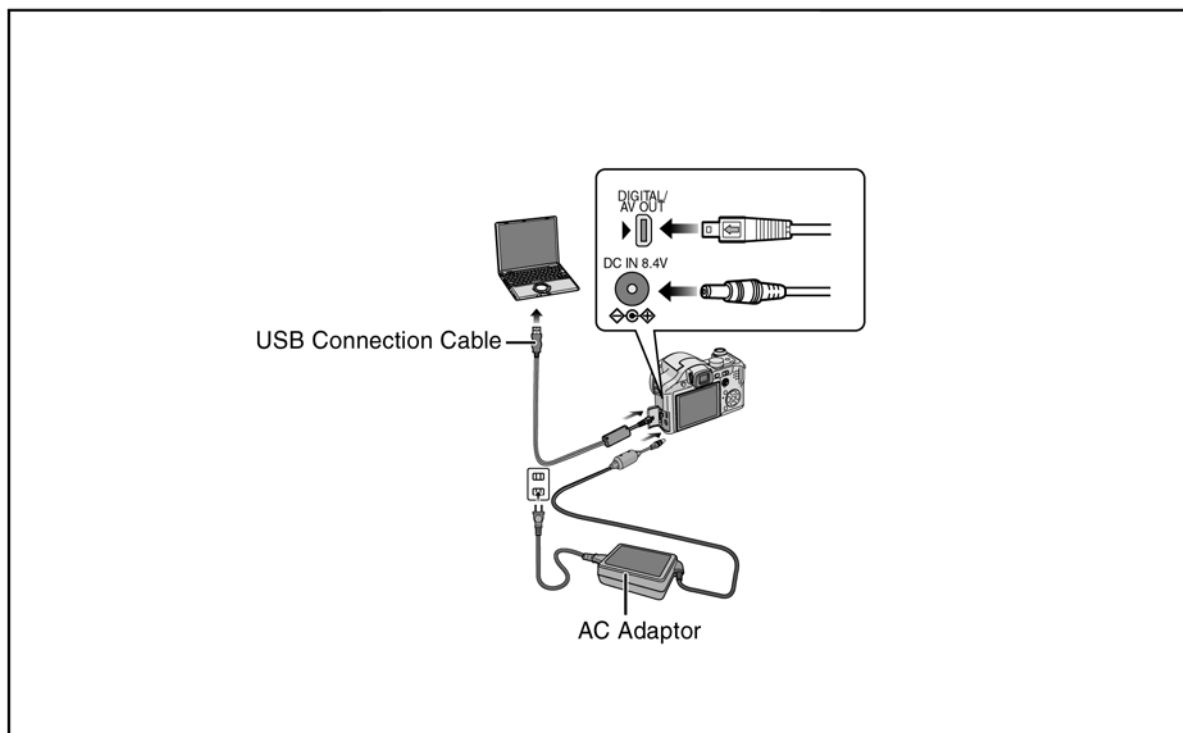



# 10 Maintenance

## 10.1. Cleaning Lens, Viewfinder and LCD Panel

Do not touch the surface of lens, Viewfinder and LCD Panel with your hand.

When cleaning the lens, use air-Blower to blow off the dust.

When cleaning the LCD Panel, dampen the lens cleaning paper with lens cleaner, and the gently wipe the their surface.

**Note:**

The Lens Cleaning KIT ; VFK1900BK(Only supplied as 10 set/Box) is available as Service Aid.

# Service Manual

---

## Diagrams and Replacement Parts List

### Digital Camera

Model No.

DMC-FZ8P	DMC-FZ8EGM
DMC-FZ8PC	DMC-FZ8GC
DMC-FZ8PL	DMC-FZ8GD
DMC-FZ8EB	DMC-FZ8GK
DMC-FZ8EE	DMC-FZ8GN
DMC-FZ8EF	DMC-FZ8GT
DMC-FZ8EG	DMC-FZ8SG

Vol. 1

Colour

(S).....Silver Type (except PL/GD/GT)

(K).....Black Type

### Table of contents

S1. About Indication of The Schematic Diagram.....	S-1	S6. Exploded View .....	S-15
S1.1. Important Safety Notice.....	S-1	S6.1. Frame and Casing Section (1).....	S-15
S2. Block Diagram.....	S-2	S6.2. Frame and Casing Section (2).....	S-16
S2.1. Overall Block Diagram .....	S-2	S6.3. Packing Parts and Accessories Section.....	S-17
S3. Schematic Diagram.....	S-3		
S3.1. Interconnection Diagram .....	S-3		
S3.2. AF LED/Mic Schematic Diagram.....	S-4		
S3.3. CCD Flex Schematic Diagram .....	S-4		
S3.4. Lens Flex Schematic Diagram .....	S-5		
S4. Print Circuit Board.....	S-6		
S4.1. AF LED/Mic P.C.B. ....	S-6		
S4.2. CCD Flex P.C.B.....	S-6		
S4.3. Lens Flex P.C.B.....	S-7		
S5. Replacement Parts List.....	S-9		

## S1. About Indication of The Schematic Diagram

### S1.1. Important Safety Notice

COMPONENTS IDENTIFIED WITH THE MARK  $\triangle$  HAVE THE SPECIAL CHARACTERISTICS FOR SAFETY. WHEN REPLACING ANY OF THESE COMPONENTS USE ONLY THE SAME TYPE.

1. Although reference number of the parts is indicated on the P.C.B. drawing and/or schematic diagrams, it is NOT mounted on the P.C.B. when it is displayed with "\$" mark.
2. It is only the "Test Round" and no terminal (Pin) is available on the P.C.B. when the TP (Test Point) indicated as "●" mark.
3. The voltage being indicated on the schematic diagram is measured in "Standard-Playback" mode when there is no specify mode is mentioned.
4. Although the voltage and waveform available on here is measured with standard frame, it may be differ from actual measurement due to modification of circuit and so on.
5. The voltage being indicated here may be include observational-error (deviation) due to internal-resistance and/or reactance of equipment. Therefore, handle the value indicated on here as reference.
6. Use the parts number indicated on the Replacement Parts List .
7. Indication on Schematic diagrams:

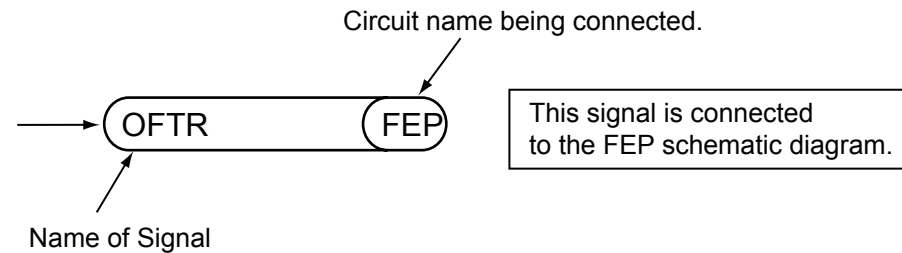

## S2. Block Diagram

### S2.1. Overall Block Diagram

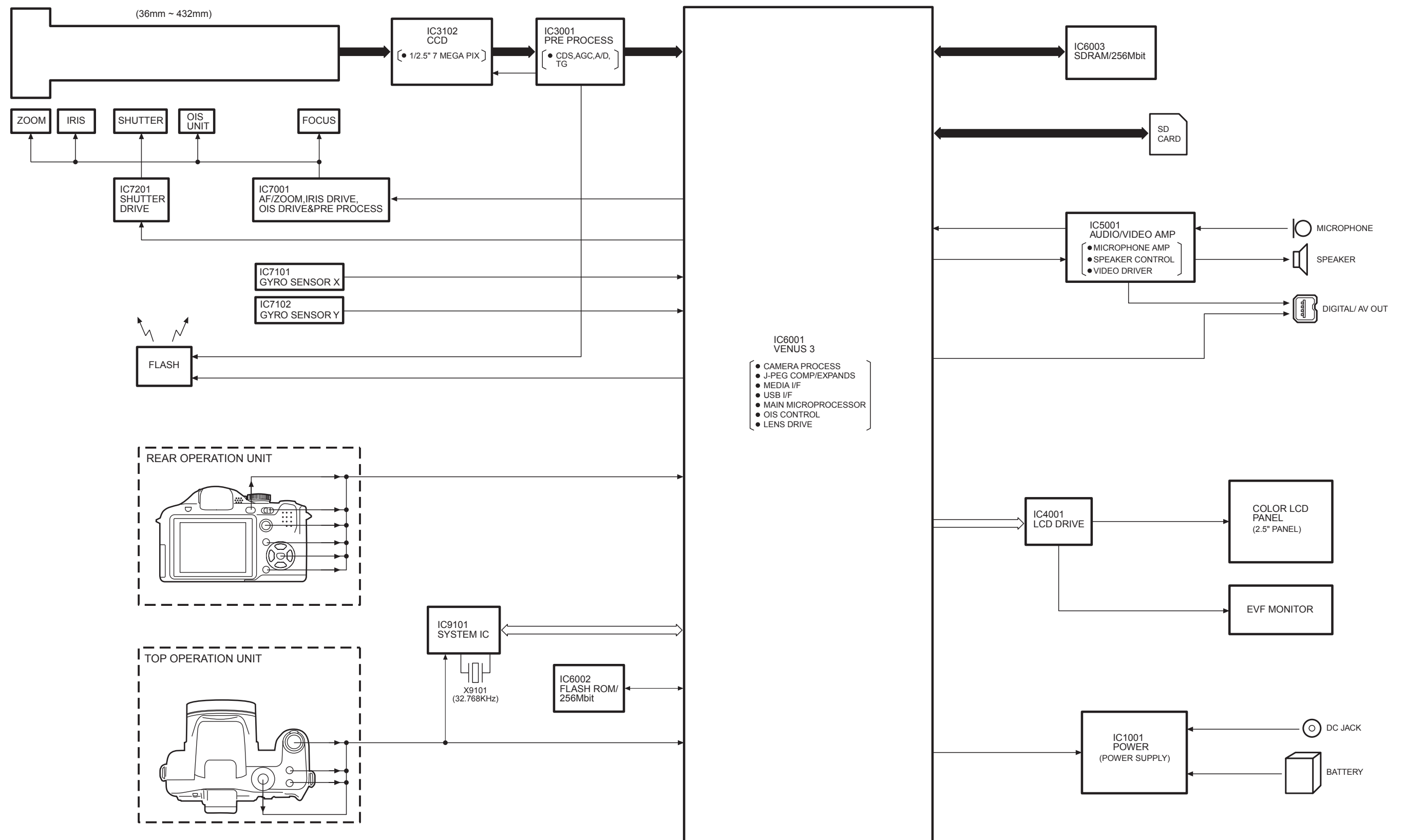

# S3. Schematic Diagram

## S3.1. Interconnection Diagram

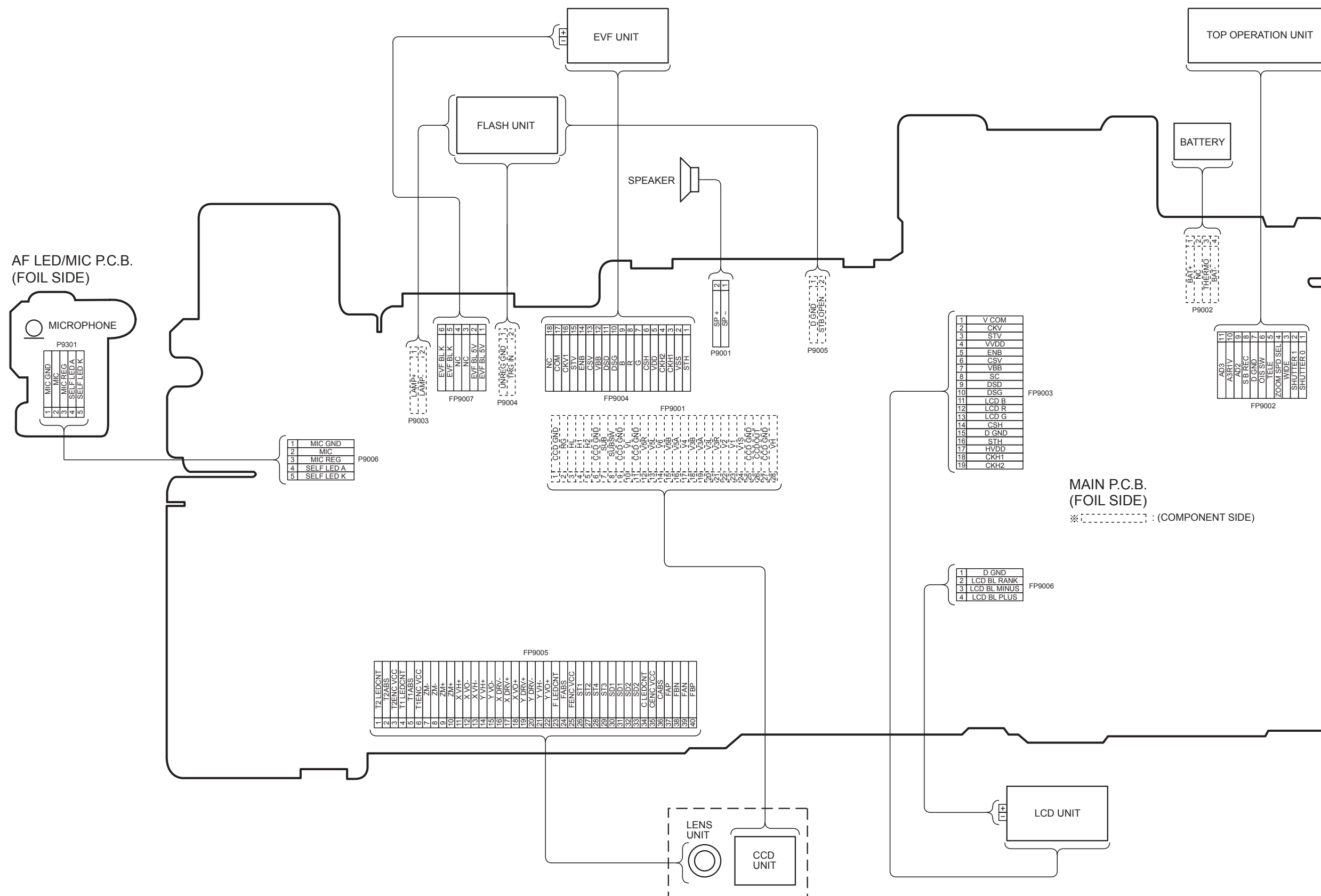

S3.2. AF LED/Mic Schematic Diagram / S3.3. CCD Flex Schematic Diagram

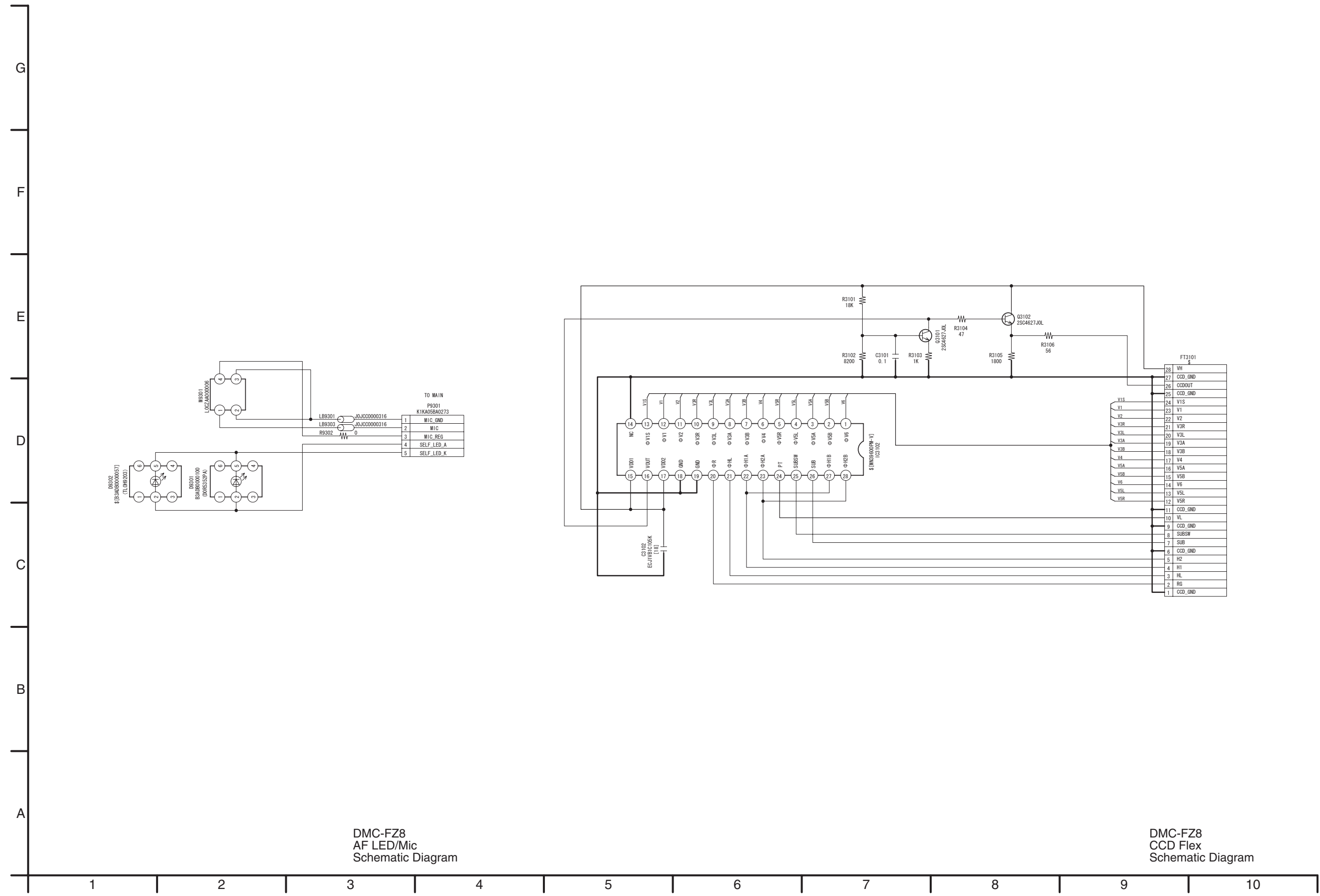

DMC-FZ8  
AF LED/Mic  
Schematic Diagram

DMC-FZ8  
CCD Flex  
Schematic Diagram

### S3.4. Lens Flex Schematic Diagram

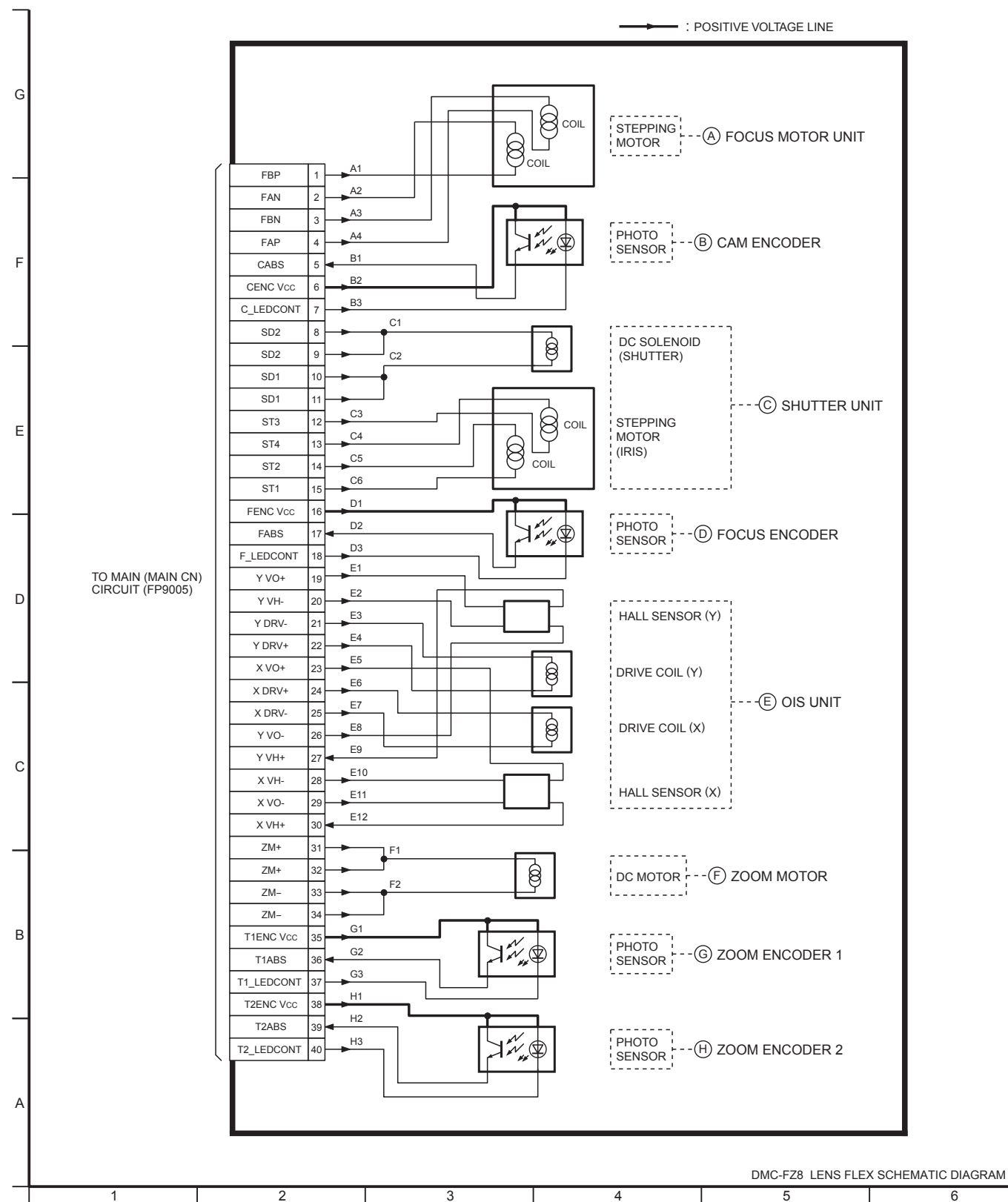

# S4. Print Circuit Board

## S4.1. AF LED/Mic P.C.B. / S4.2. CCD Flex P.C.B.

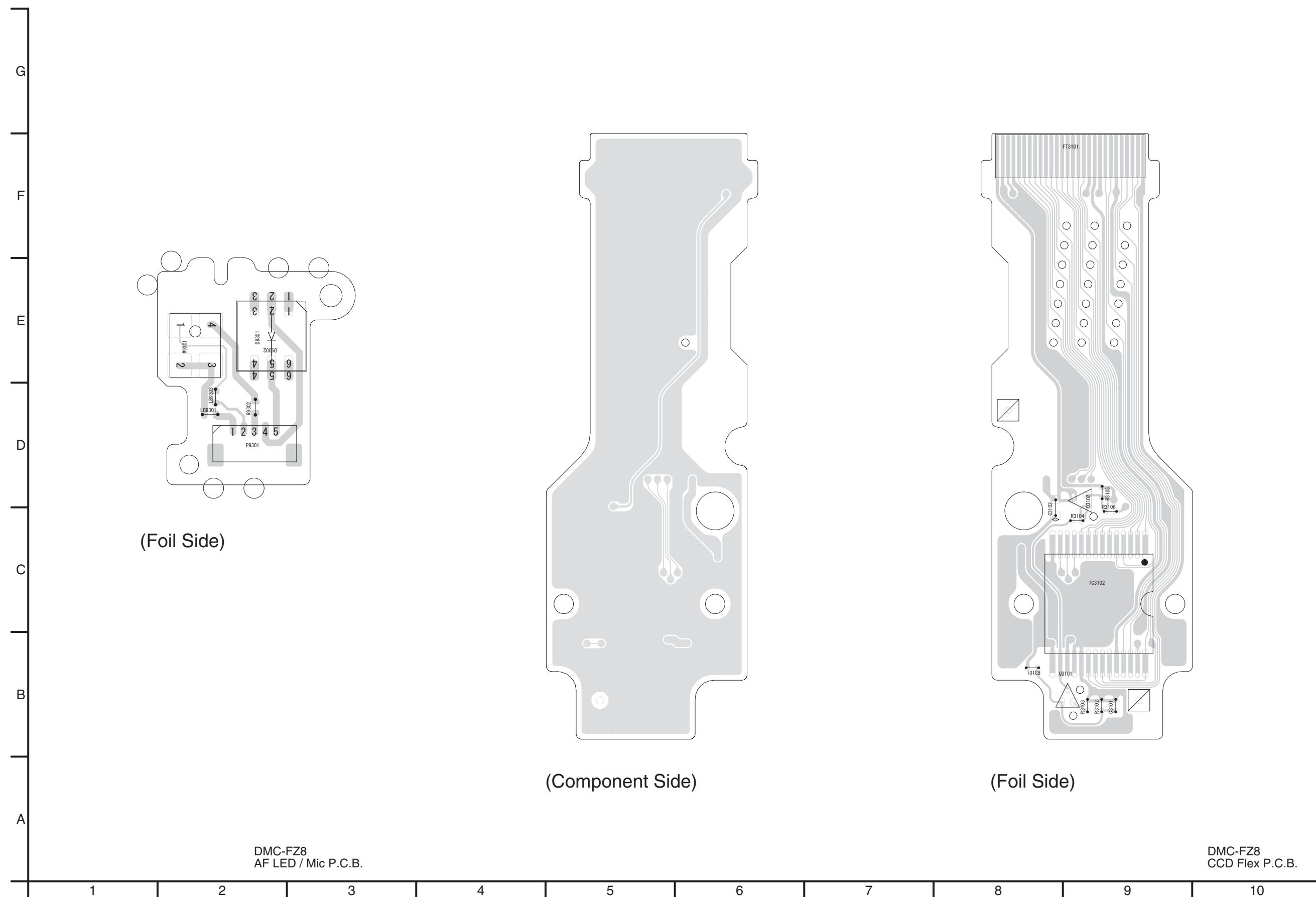

S4.3. Lens Flex P.C.B.

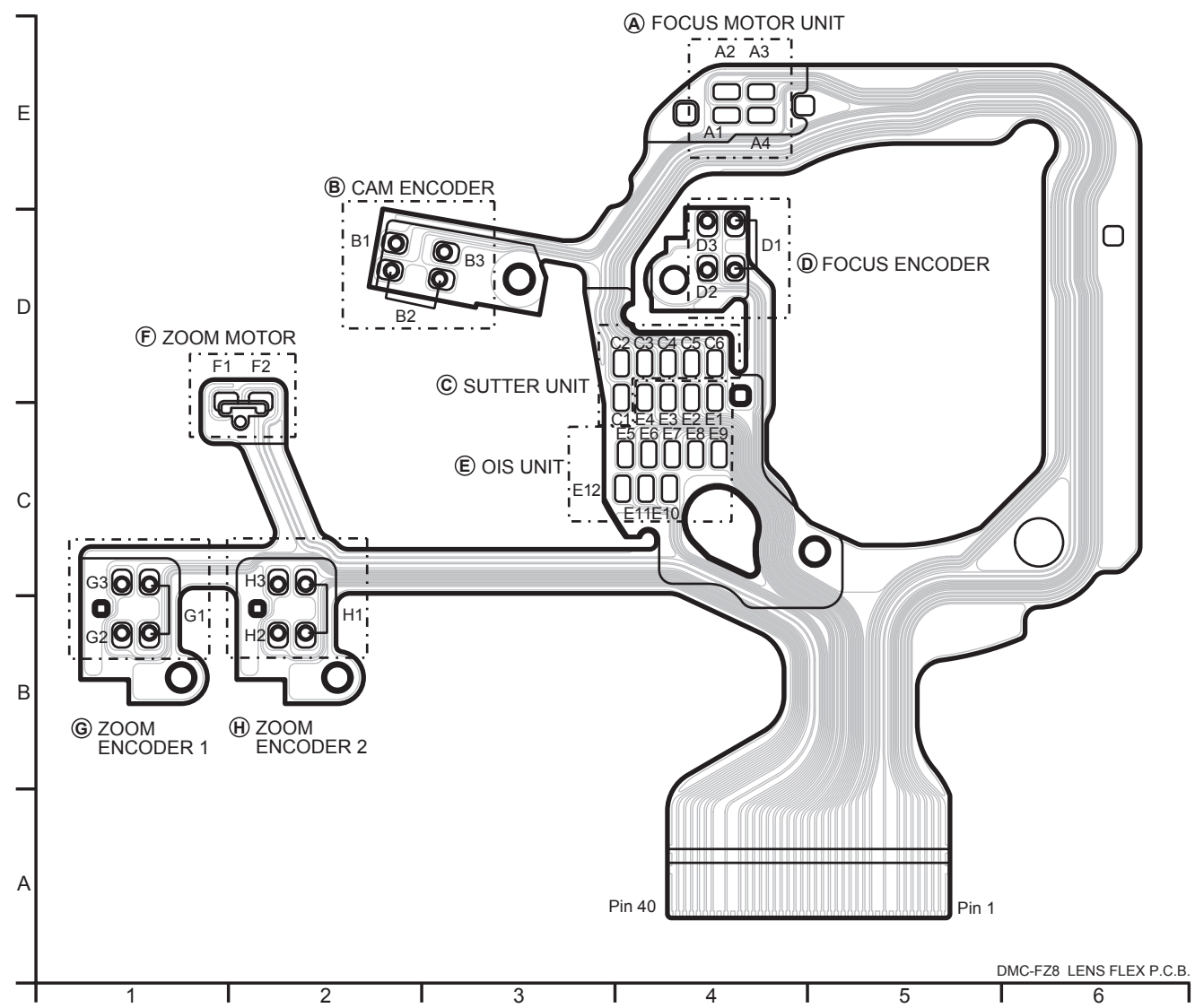





## S5. Replacement Parts List

- Note: 1.\* Be sure to make your orders of replacement parts according to this list.
2. IMPORTANT SAFETY NOTICE  
Components identified with the mark  $\triangle$  have the special characteristics for safety.  
When replacing any of these components, use only the same type.
3. Unless otherwise specified,  
All resistors are in OHMS, K=1,000 OHMS. All capacitors are in MICRO-FARADS (uf), P=uuF.
4. The marking (RTL) indicates the retention time is limited for this item. After the discontinuation of this assembly in production, it will no longer be available.

**E.S.D. standards for Electrostatically Sensitive Devices, refer to “PREVENTION OF ELECTROSTATIC DISCHARGE (ESD) TO ELECTROSTATICALLY SENSITIVE (ES) DEVICES” section.**

**Definition of Parts supplier:**

1. Parts marked with [MBI] in the remarks column are supplied from  
“Matsushita Battery Industrial Co., Ltd.”
  
2. Parts marked with [PAVC-CSG] in the remarks column are supplied from  
PAVC COMPANY CS Group (PAVC-CSG).  
Others are supplied from “Panasonic Shikoku Electronics Co., Ltd.” (PSEC-SAIJO).







DMC-FZ8EB-S/K,EF-S/K,EGM-S/K,EG-S/K,PL-K,EE-S/K,GC-S/K,GD-K,GN-S/K,GK-S/K,GT-K,SG-S/K,P-S/K,PC-S/K

Ref.No.	Part No.	Part Name & Description	Pcs	Remarks
2	VDW1402	LENS RING FRONT	1 (-S)	
2	VDW1403	LENS RING FRONT	1 (-K)	
3	VGU0A71	FLASH LOCK LEVER KNOB	1 (-S)	
3	VGU9907	FLASH LOCK LEVER KNOB	1 (-K)	
4	VYK1250	FRONT CASE UNIT	1 (-S)	
4	VYK1251	FRONT CASE UNIT	1 (-K)	
4-1	VGQ9264	GRIP PIECE FRONT	1 (-S) [PAVC-CSG]	
4-1	VGQ8737	GRIP PIECE FRONT	1 (-K) [PAVC-CSG]	
4-2	VMS7523	STRAP HOLDER	1 [PAVC-CSG]	
8	VYK1257	FLASH UNIT	1 (-S)	
8	VYK1258	FLASH UNIT	1 (-K)	
8-1	VKM7055	FLASH CASE TOP	1 (-S)	
8-1	VKM6873	FLASH CASE TOP	1 (-K)	
8-2	VYQ3749	FLASH SW UNIT	1	
10	VYQ3898	EVF UNIT	1 (-S)	
10	VYQ3899	EVF UNIT	1 (-K)	
20	VYQ3616	JACK DOOR UNIT	1 (-K)	
20	VYQ3903	JACK DOOR UNIT	1 (-S)	
53	VXP2452	2ND LENS FRAME UNIT	1 [PAVC-CSG]	
54	VDW1147	MIDDLE FRAME	1 [PAVC-CSG]	
55	L6HA88NC0005	FOCUS MOTOR UNIT	1 [PAVC-CSG]	
56	VXP2739	3RD LENS FRAME UNIT	1 [PAVC-CSG]	
57	VXP2459	4TH LENS FRAME UNIT	1 [PAVC-CSG]	
58	VDW1167	CAM FRAME	1 [PAVC-CSG]	
59	VDW1431	MASTER FLANGE	1 [PAVC-CSG]	
60	L6DAAAHB0001	ZOOM MOTOR UNIT	1 [PAVC-CSG]	
61	VEK0K90	LENS FLEX. UNIT	1 [PAVC-CSG]	
61-1	B3NAA0000074	PHOTO SENSOR	1 [PAVC-CSG]	
61-2	B3NAA0000074	PHOTO SENSOR	1 [PAVC-CSG]	
61-3	B3NAA0000074	PHOTO SENSOR	1 [PAVC-CSG]	
61-4	B3NAA0000074	PHOTO SENSOR	1 [PAVC-CSG]	
62	VDL1946	OPTICAL FILTER	1 [PAVC-CSG]	
63	VMX3571	CCD CUSHION RUBBER	1 [PAVC-CSG]	
64	VEK0K82	CCD UNIT	1 [PAVC-CSG] E.S.D.	
65	VXP2683	1ST LENS FRAME UNIT	1 (-S) [PAVC-CSG]	
65	VXP2682	1ST LENS FRAME UNIT	1 (-K) [PAVC-CSG]	
71	VMS7580	FOCUS GUIDE POLE	1 [PAVC-CSG]	
72	VMS7580	FOCUS GUIDE POLE	1 [PAVC-CSG]	
73	VXW0884	LENS UNIT(W/O CCD)	1 (-S) [PAVC-CSG]	
73	VXW0885	LENS UNIT(W/O CCD)	1 (-K) [PAVC-CSG]	
B1	VHD1680	SCREW	1 (-S)	
B1	VHD1684	SCREW	1 (-K)	
B5	XQN16+BJ4FN	SCREW	1	
B6	XQN16+BJ4FN	SCREW	1	
B7	VHD1869	SCREW	1	
B8	VHD1869	SCREW	1	
B9	VHD1869	SCREW	1	
B10	VHD1839	SCREW	1	
B14	XQN16+BJ6FN	SCREW	1	
B15	XQN16+BJ8FN	SCREW	1	
B16	XQN16+BJ8FN	SCREW	1	
B21	XQN16+BJ5FN	SCREW	1 (-S)	
B21	VHD1870	SCREW	1 (-K)	
B24	VHD1680	SCREW	1 (-S)	
B24	VHD1684	SCREW	1 (-K)	
B25	VHD1765	SCREW	1	
B26	VHD1765	SCREW	1	
B27	VHD1765	SCREW	1	
B50	XQN14+CJ3FN	SCREW	1 [PAVC-CSG]	
B51	XQN14+CJ3FN	SCREW	1 [PAVC-CSG]	
B52	XQN14+CJ3FN	SCREW	1 [PAVC-CSG]	
B53	XQN16+CJ5FJ	SCREW	1 [PAVC-CSG]	
B54	XQN16+CJ5FJ	SCREW	1 [PAVC-CSG]	
B55	XQN16+CJ5FJ	SCREW	1 [PAVC-CSG]	
B56	XQN16+CJ5FJ	SCREW	1 [PAVC-CSG]	
B57	XQN16+CJ5FJ	SCREW	1 [PAVC-CSG]	
B58	XQN16+CJ5FJ	SCREW	1 [PAVC-CSG]	
B59	XQN16+CJ5FJ	SCREW	1 [PAVC-CSG]	
B60	XQN16+CJ5FJ	SCREW	1 [PAVC-CSG]	
B61	XQN16+CJ5FJ	SCREW	1 [PAVC-CSG]	
B62	XQN16+CJ5FJ	SCREW	1 [PAVC-CSG]	
B63	XQN16+CJ5FJ	SCREW	1 [PAVC-CSG]	

Ref.No.	Part No.	Part Name & Description	Pcs	Remarks
1	K0RB01000010	TOP OPERATION UNIT	1 (-S)	
1	K0RB01000011	TOP OPERATION UNIT	1 (-K)	
11	K1ZZ00001294	BATTERY CACHER	1	
12	VEE1C18	AF LED & MIC WIRE	1	
13	VEP56045A	MAIN P.C.B.	1 E.S.D.(RTL)	
14	VGQ8573	JOY COVER	1	
15	VGQ9383	CONDENSER HOLDER	1	
16	VGQ8747	AF LED PCB HOLDER	1	
17	VGU9911-1	JOY STICK KNOB	1	
18	VYK1Z54	BATTERY FRAME UNIT	1 (-S)	
18	VYK1Z89	BATTERY FRAME UNIT	1 (-K)	
18-1	VMB4039	BATTERY SPRING	1 [PAVC-CSG]	
21	VEP59038A	AF LED/MIC P.C.B.	1 E.S.D.(RTL)	
22	VYQ3750	MIC DAMPER UNIT	1	
24	L0AA01A00022	SPEAKER	1	
25	VMP8830	LCD HOLDER	1	
26	VMP8761	SP FIX PLATE	1	
32	VYQ3906	LCD UNIT	1	
35	VUK1Z52	REAR CASE UNIT	1 (-S) [PAVC-CSG]	
35	VUK1Z53	REAR CASE UNIT	1 (-K) [PAVC-CSG]	
35-1	VGU0A72	POWER KNOB	1 (-S) [PAVC-CSG]	
35-1	VGU9910-1	POWER KNOB	1 (-K) [PAVC-CSG]	
35-2	VGU0A74	EVF BUTTON	1 (-S) [PAVC-CSG]	
35-2	VGU9915-1	EVF BUTTON	1 (-K) [PAVC-CSG]	
35-3	VMS7523	STRAP HOLDER	1 [PAVC-CSG]	
35-4	VGU0A73	MENU BUTTON	1 (-S) [PAVC-CSG]	
35-4	VGU9913-1	MENU BUTTON	1 (-K) [PAVC-CSG]	
35-5	VGQ8748	POWER LED PIECE	1 [PAVC-CSG]	
37	VGQ8438	SHEET	1	
B2	VHD1680	SCREW	1 (-S)	
B2	VHD1684	SCREW	1 (-K)	
B3	VHD1680	SCREW	1 (-S)	
B3	VHD1684	SCREW	1 (-K)	
B11	VHD1680	SCREW	1	
B13	XQN16+BJ4FN	SCREW	1	
B17	XQN16+BJ4FN	SCREW	1 [PAVC-CSG]	
B18	XQN16+BJ4FN	SCREW	1	
B19	XQN16+BJ4FN	SCREW	1	
B20	XQN16+BJ4FN	SCREW	1	
B22	XQN16+BJ5FN	SCREW	1 (-S)	
B22	VHD1870	SCREW	1 (-K)	
B23	XQN16+BJ5FN	SCREW	1 (-S)	
B23	VHD1870	SCREW	1 (-K)	

DMC-FZ8EB-S/K,EF-S/K,EGM-S/K,EG-S/K,PL-K,EE-S/K,GC-S/K,GD-K,GN-S/K,GK-S/K,GT-K,SG-S/K,P-S/K,PC-S/K

Ref.No.	Part No.	Part Name & Description	Pcs	Remarks
▲ 100	-----	BATTERY	1	
▲ 101	DE-A44AA	BATTERY CHARGER	1	EB,EF,EGM,EG,GN
▲ 101	DE-A43BA	BATTERY CHARGER	1	PL,P,PC
▲ 101	DE-A44CA	BATTERY CHARGER	1	GT
▲ 101	DE-A44BA	BATTERY CHARGER	1	EE,GC,GD,GK,SG
102	K1HA08CD0013	USB CABLE	1	[PAVC-CSG]
103	K1HA08CD0014	AV CABLE	1	[PAVC-CSG]
105	VFC4160	STRAP	1	
106	VFF0364-S	CD-ROM	1	(EXCEPT P/PC) See "Notes" [PAVC-CSG]
106	VFF0363-S	CD-ROM	1	P,PC See "Notes" [PAVC-CSG]
108	VPF1100	BAG, POLYETHYLENE	1	EB,EF,EE,GD,GN,GK .GT,P,PC [PAVC-CSG]
108	VPF1132	BAG, POLYETHYLENE	1	EGM,EG,PL,GC,SG [PAVC-CSG]
▲ 110	VQT1B38	OPERATING INSTRUCTIONS (ENGLISH)	1	EB [PAVC-CSG]
▲ 110	VQT1B31	OPERATING INSTRUCTIONS (FRENCH)	1	EF,EG [PAVC-CSG]
▲ 110	VQT1B34	OPERATING INSTRUCTIONS (SPANISH)	1	EGM [PAVC-CSG]
▲ 110	VQT1B35	OPERATING INSTRUCTIONS (PORTUGUESE)	1	EGM [PAVC-CSG]
▲ 110	VQT1B36	OPERATING INSTRUCTIONS (SWEDISH)	1	EGM [PAVC-CSG]
▲ 110	VQT1B37	OPERATING INSTRUCTIONS (DANISH)	1	EGM [PAVC-CSG]
▲ 110	VQT1B30	OPERATING INSTRUCTIONS (GERMAN)	1	EG [PAVC-CSG]
▲ 110	VQT1B32	OPERATING INSTRUCTIONS (ITALIAN)	1	EG [PAVC-CSG]
▲ 110	VQT1B33	OPERATING INSTRUCTIONS (DUTCH)	1	EG [PAVC-CSG]
▲ 110	VQT1B27	OPERATING INSTRUCTIONS (ENGLISH)	1	PL [PAVC-CSG]
▲ 110	VQT1B28	OPERATING INSTRUCTIONS (SPANISH)	1	PL [PAVC-CSG]
▲ 110	VQT1B29	OPERATING INSTRUCTIONS (PORTUGUESE)	1	PL [PAVC-CSG]
▲ 110	VQT1B39	OPERATING INSTRUCTIONS (RUSSIAN)	1	EE [PAVC-CSG]
▲ 110	VQT1B40	OPERATING INSTRUCTIONS (UKRAINIAN)	1	EE [PAVC-CSG]
▲ 110	VQT1B41	OPERATING INSTRUCTIONS (ENGLISH)	1	GC,SG [PAVC-CSG]
▲ 110	VQT1B42	OPERATING INSTRUCTIONS (CHINESE (TRADITIONAL))	1	GC,SG [PAVC-CSG]
▲ 110	VQT1B43	OPERATING INSTRUCTIONS (ARABIC)	1	GC,SG [PAVC-CSG]
▲ 110	VQT1B44	OPERATING INSTRUCTIONS (PERSIAN)	1	GC,SG [PAVC-CSG]
▲ 110	VQT1B48	OPERATING INSTRUCTIONS (KOREAN)	1	GD [PAVC-CSG]
▲ 110	VQT1B47	OPERATING INSTRUCTIONS (ENGLISH)	1	GN [PAVC-CSG]
▲ 110	VQT1B46	OPERATING INSTRUCTIONS (CHINESE (SIMPLIFIED))	1	GK [PAVC-CSG]
▲ 110	VQT1B45	OPERATING INSTRUCTIONS (CHINESE (TRADITIONAL))	1	GT [PAVC-CSG]
▲ 110	VQT1B25	OPERATING INSTRUCTIONS (ENGLISH (SPANISH))	1	P,PC [PAVC-CSG]
▲ 110	VQT1E34	OPERATING INSTRUCTIONS (SPANISH)	1	P [PAVC-CSG]
▲ 110	VQT1B26	OPERATING INSTRUCTIONS (CANADIAN FRENCH)	1	PC [PAVC-CSG]
111	VQT1D49	O/I PC CONNECTION (ENGLISH)	1	EB,GN [PAVC-CSG]
111	VQT1D48	O/I PC CONNECTION (FRENCH)	1	EF [PAVC-CSG]
111	VQT1D47	O/I PC CONNECTION (SPANISH/PORTUGUESE/ SWEDISH/DANISH)	1	EGM [PAVC-CSG]

Ref.No.	Part No.	Part Name & Description	Pcs	Remarks
111	VQT1D46	O/I PC CONNECTION (GERMAN/FRENCH/ITALIAN/ DUTCH)	1	EG [PAVC-CSG]
111	VQT1D45	O/I PC CONNECTION (ENGLISH/SPANISH/ PORTUGUESE)	1	PL [PAVC-CSG]
111	VQT1D50	O/I PC CONNECTION (RUSSIAN/UKRAINIAN)	1	EE [PAVC-CSG]
111	VQT1D51	O/I PC CONNECTION (ENGLISH/ARABIC/PERSIAN/ CHINESE (TRADITIONAL))	1	GC,SG [PAVC-CSG]
111	VQT1D54	O/I PC CONNECTION (KOREAN)	1	GD [PAVC-CSG]
111	VQT1D53	O/I PC CONNECTION (CHINESE (SIMPLIFIED))	1	GK [PAVC-CSG]
111	VQT1D52	O/I PC CONNECTION (CHINESE (TRADITIONAL))	1	GT [PAVC-CSG]
111	VQT1D44	O/I PC CONNECTION (ENGLISH)	1	P,PC [PAVC-CSG]
111	VQT1D67	O/I PC CONNECTION (ENGLISH/ARABIC/PERSIAN/ CHINESE (TRADITIONAL))	1	GC,SG [PAVC-CSG]
111	VQT1D70	O/I PC CONNECTION (KOREAN)	1	GD [PAVC-CSG]
111	VQT1D69	O/I PC CONNECTION (CHINESE (SIMPLIFIED))	1	GK [PAVC-CSG]
111	VQT1D68	O/I PC CONNECTION (CHINESE (TRADITIONAL))	1	GT [PAVC-CSG]
112	VQT1D61	O/I SOFTWARE (ENGLISH)	1	EB,GN [PAVC-CSG]
112	VQT1D60	O/I SOFTWARE (FRENCH)	1	EF [PAVC-CSG]
112	VQT1D59	O/I SOFTWARE (SPANISH/PORTUGUESE/ SWEDISH/DANISH)	1	EGM [PAVC-CSG]
112	VQT1D58	O/I SOFTWARE (GERMAN/FRENCH/ITALIAN/ DUTCH)	1	EG [PAVC-CSG]
112	VQT1D57	O/I SOFTWARE (ENGLISH/SPANISH/ PORTUGUESE)	1	PL [PAVC-CSG]
112	VQT1D62	O/I SOFTWARE (RUSSIAN/UKRAINIAN)	1	EE [PAVC-CSG]
112	VQT1D56	O/I SOFTWARE (ENGLISH/CANADIAN FRENCH)	1	P,PC [PAVC-CSG]
113	VYK1T69	LENS CAP UNIT	1	
116	VYQ3997	LENS HOOD UNIT	1	(-S) [PAVC-CSG]
116	VYQ3981	LENS HOOD UNIT	1	(-K) [PAVC-CSG]
117	VYQ3998	LENS ADAPTOR UNIT	1	(-S) [PAVC-CSG]
117	VYQ3797	LENS ADAPTOR UNIT	1	(-K) [PAVC-CSG]
118	VPF1166	CAMERA BAG	1	
120	VPK3231	PACKING CASE	1	(-S) EB,EF,EGM,EG EE,GC,GN,SG
120	VPK3235	PACKING CASE	1	(-K) EB,EF,EGM,EG .PL,EE,GC,GD,GN,GT,SG
120	VPK3232	PACKING CASE	1	GK-S
120	VPK3236	PACKING CASE	1	GK-K
120	VPK3230	PACKING CASE	1	P-S,PC-S
120	VPK3234	PACKING CASE	1	P-K,PC-K
123	VPN6542	CUSHION	1	
▲ 124	K2CQ2CA00006	AC CORD W/PLUG	1	EF,EGM,EG,EE,GC,SG
▲ 124	K2CR2DA00004	AC CORD W/PLUG	1	EF,EGM,EG,EE,GC
▲ 125	K2CT3CA00004	AC CORD W/PLUG	1	EB,GC,SG
▲ 126	K2CA2CA00020	AC CORD W/PLUG	1	GK
▲ 126	K2CA2CA00027	AC CORD W/PLUG	1	GT
▲ 128	K2CJ2DA00008	AC CORD W/PLUG	1	GN
▲ 129	RJA0078-1X	AC CORD W/PLUG	1	GD

# S6. Exploded View

## S6.1. Frame and Casing Section (1)

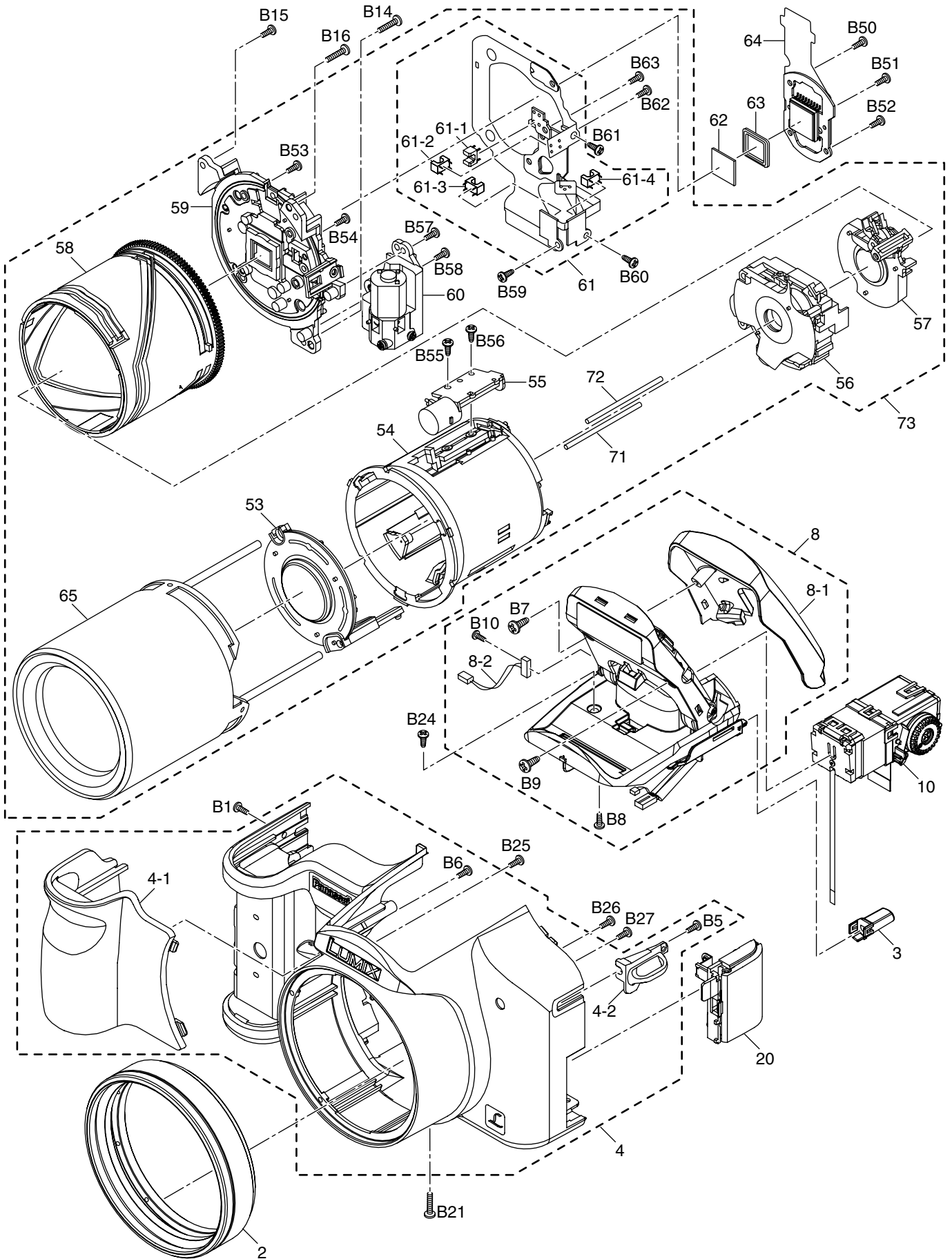



## S6.2. Frame and Casing Section (2)

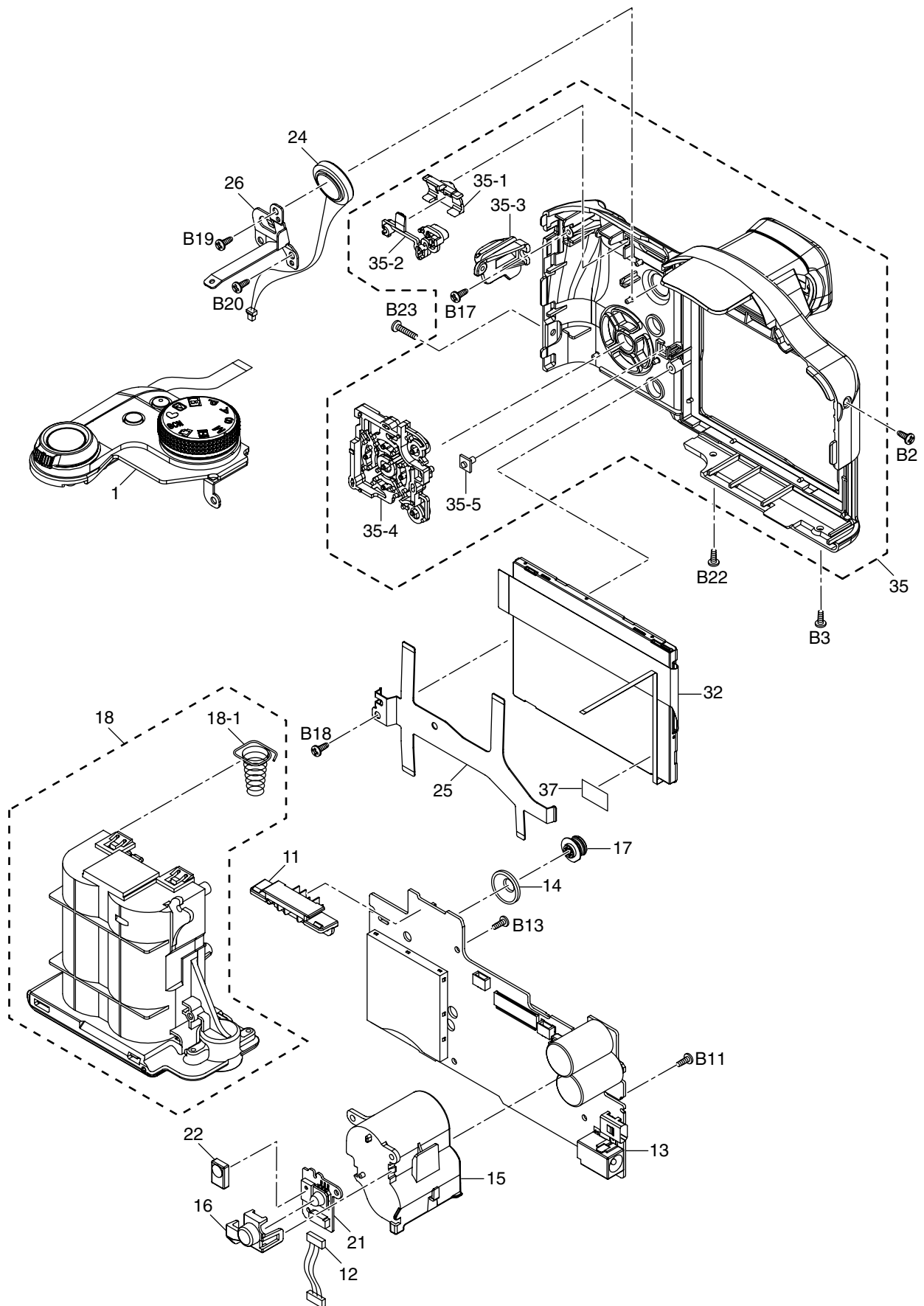

### S6.3. Packing Parts and Accessories Section

