

# Service Manual

Digital Camera

LUMIX  HDMI

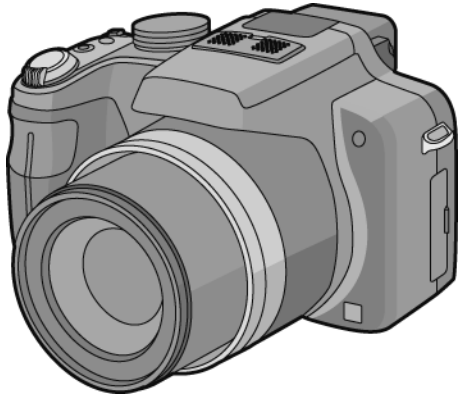

Model No. **DMC-FZ40P**  
**DMC-FZ40PC**  
**DMC-FZ40PR**  
**DMC-FZ40PU**  
**DMC-FZ40GC**  
**DMC-FZ40GK**  
**DMC-FZ40GN**  
**DMC-FZ40GT**  
**DMC-FZ45EB**  
**DMC-FZ45EE**  
**DMC-FZ45EF**  
**DMC-FZ45EG**  
**DMC-FZ45EP**

Vol. 1  
Colour  
(K).....Black Type

## **WARNING**

This service information is designed for experienced repair technicians only and is not designed for use by the general public. It does not contain warnings or cautions to advise non-technical individuals of potential dangers in attempting to service a product. Products powered by electricity should be serviced or repaired only by experienced professional technicians. Any attempt to service or repair the product or products dealt with in this service information by anyone else could result in serious injury or death.

**Panasonic**<sup>®</sup>

© Panasonic Corporation 2010 Unauthorized copying and distribution is a violation of law.

# TABLE OF CONTENTS

	PAGE	PAGE
<b>1 Safety Precautions</b> .....	<b>3</b>	
1.1. General Guidelines .....	3	
1.2. Leakage Current Cold Check .....	3	
1.3. Leakage Current Hot Check (See Figure 1.) .....	3	
1.4. How to Discharge the E.Capacitor on Flash P.C.B. ....	4	
<b>2 Warning</b> .....	<b>5</b>	
2.1. Prevention of Electrostatic Discharge (ESD) to Electrostatically Sensitive (ES) Devices .....	5	
2.2. How to Recycle the Lithium Ion Battery (U.S. Only) .....	5	
2.3. Caution for AC Cord(For EB/GC) .....	6	
2.4. How to Replace the Lithium Battery .....	7	
<b>3 Service Navigation</b> .....	<b>8</b>	
3.1. Introduction .....	8	
3.2. General Description About Lead Free Solder (PbF) .....	8	
3.3. Important Notice 1:(Other than U.S.A. and Canadian Market) .....	8	
3.4. How to Define the Model Suffix (NTSC or PAL model) .....	9	
<b>4 Specifications</b> .....	<b>13</b>	
<b>5 Location of Controls and Components</b> .....	<b>14</b>	
<b>6 Service Mode</b> .....	<b>18</b>	
6.1. Error Code Memory Function .....	18	
6.2. ICS (Indication of additional Camera Settings when picture was taken) function .....	20	
<b>7 Service Fixture &amp; Tools</b> .....	<b>22</b>	
7.1. Service Fixture and Tools .....	22	
7.2. When Replacing the Main P.C.B. ....	23	
7.3. Service Position .....	23	
<b>8 Disassembly and Assembly Instructions</b> .....	<b>24</b>	
8.1. Disassembly Flow Chart .....	24	
8.2. P.C.B. Location .....	24	
8.3. Disassembly Procedure .....	25	
8.4. Lens Disassembly Procedure .....	32	
8.5. Removal of the CCD Unit .....	37	
<b>9 Measurements and Adjustments</b> .....	<b>38</b>	
9.1. Introduction .....	38	
9.2. Before Disassembling the unit .....	38	
9.3. Details of Electrical Adjustment .....	40	
9.4. After Adjustment .....	43	
<b>10 Maintenance</b> .....	<b>44</b>	
10.1. Cleaning Lens, Viewfinder and LCD Panel .....	44	

# 1 Safety Precautions

## 1.1. General Guidelines

### 1. IMPORTANT SAFETY NOTICE

There are special components used in this equipment which are important for safety. These parts are marked by

 in the Schematic Diagrams, Circuit Board Layout, Exploded Views and Replacement Parts List. It is essential that these critical parts should be replaced with manufacturer's specified parts to prevent X-RADIATION, shock, fire, or other hazards. Do not modify the original design without permission of manufacturer.

2. An Isolation Transformer should always be used during the servicing of AC Adaptor whose chassis is not isolated from the AC power line. Use a transformer of adequate power rating as this protects the technician from accidents resulting in personal injury from electrical shocks. It will also protect AC Adaptor from being damaged by accidental shorting that may occur during servicing.
3. When servicing, observe the original lead dress. If a short circuit is found, replace all parts which have been overheated or damaged by the short circuit.
4. After servicing, see to it that all the protective devices such as insulation barriers, insulation papers shields are properly installed.
5. After servicing, make the following leakage current checks to prevent the customer from being exposed to shock hazards.

## 1.2. Leakage Current Cold Check

1. Unplug the AC cord and connect a jumper between the two prongs on the plug.
2. Measure the resistance value, with an ohmmeter, between the jumpered AC plug and each exposed metallic cabinet part on the equipment such as screwheads, connectors, control shafts, etc. When the exposed metallic part has a return path to the chassis, the reading should be between  $1\text{ M}\Omega$  and  $5.2\text{ M}\Omega$ . When the exposed metal does not have a return path to the chassis, the reading must be infinity.

## 1.3. Leakage Current Hot Check (See Figure 1.)

1. Plug the AC cord directly into the AC outlet. Do not use an isolation transformer for this check.
2. Connect a  $1.5\text{ k}\Omega$ ,  $10\text{ W}$  resistor, in parallel with a  $0.15\text{ }\mu\text{F}$  capacitor, between each exposed metallic part on the set and a good earth ground, as shown in Figure 1.
3. Use an AC voltmeter, with  $1\text{ k}\Omega/\text{V}$  or more sensitivity, to measure the potential across the resistor.
4. Check each exposed metallic part, and measure the voltage at each point.
5. Reverse the AC plug in the AC outlet and repeat each of the above measurements.
6. The potential at any point should not exceed  $0.75\text{ V RMS}$ . A leakage current tester (Simpson Model 229 or equivalent) may be used to make the hot checks, leakage current must not exceed  $1/2\text{ mA}$ . In case a measurement is outside of the limits specified, there is a possibility of a shock hazard, and the equipment should be repaired and rechecked before it is returned to the customer.

Hot-Check Circuit

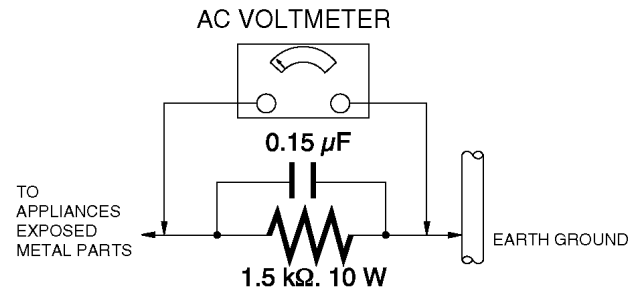

Figure. 1

## 1.4. How to Discharge the E.Capacitor on Flash P.C.B.

### CAUTION:

1. Be sure to discharge the E.capacitor on FLASH P.C.B..
2. Be careful of the high voltage circuit on FLASH P.C.B. when servicing.

### [Discharging Procedure]

1. Refer to the disassemble procedure and remove the necessary parts/unit.
2. Install the insulation tube onto the lead part of resistor (ERG5SJ102:1k $\Omega$  /5W).  
(an equivalent type of resistor may be used.)
3. Place a resistor between both terminals of E.capacitor on the FLASH P.C.B. for approx. 5 seconds.
4. After discharging, confirm that the E.capacitor voltage is lower than 10V using a voltmeter.

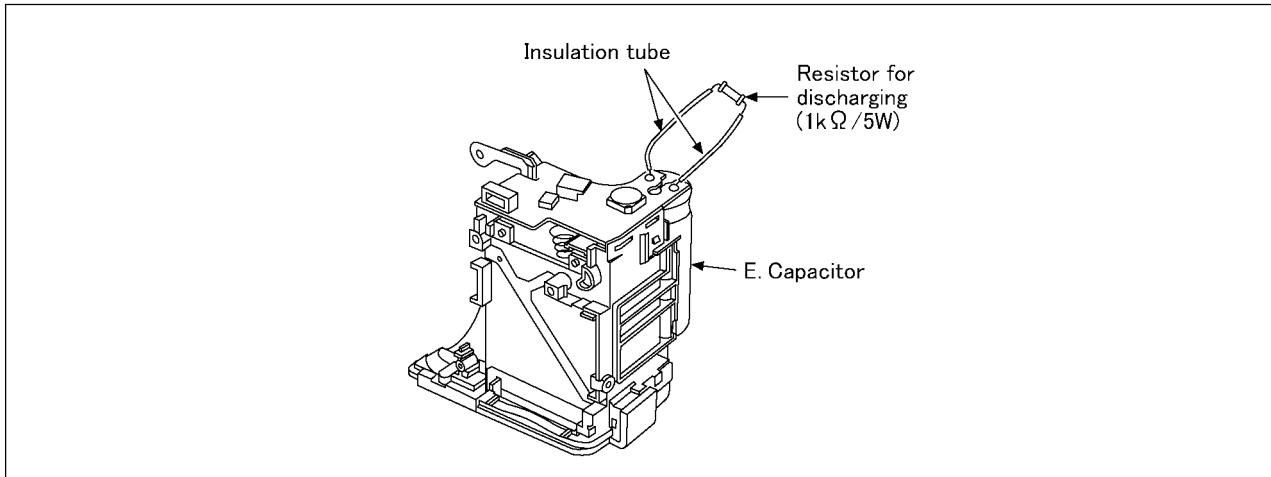

Fig. F1

## 2 Warning

### 2.1. Prevention of Electrostatic Discharge (ESD) to Electrostatically Sensitive (ES) Devices

Some semiconductor (solid state) devices can be damaged easily by static electricity. Such components commonly are called Electrostatically Sensitive (ES) Devices.

Examples of typical ES devices are CCD image sensor, IC (integrated circuits) and some field-effect transistors and semiconductor "chip" components.

The following techniques should be used to help reduce the incidence of component damage caused by electrostatic discharge (ESD).

1. Immediately before handling any semiconductor component or semiconductor-equipped assembly, drain off any ESD on your body by touching a known earth ground. Alternatively, obtain and wear a commercially available discharging ESD wrist strap, which should be removed for potential shock reasons prior to applying power to the unit under test.
2. After removing an electrical assembly equipped with ES devices, place the assembly on a conductive surface such as aluminum foil, to prevent electrostatic charge buildup or exposure of the assembly.
3. Use only a grounded-tip soldering iron to solder or unsolder ES devices.
4. Use only an antistatic solder removal device. Some solder removal devices not classified as "antistatic (ESD protected)" can generate electrical charge sufficient to damage ES devices.
5. Do not use freon-propelled chemicals. These can generate electrical charges sufficient to damage ES devices.
6. Do not remove a replacement ES device from its protective package until immediately before you are ready to install it. (Most replacement ES devices are packaged with leads electrically shorted together by conductive foam, aluminum foil or comparable conductive material).
7. Immediately before removing the protective material from the leads of a replacement ES device, touch the protective material to the chassis or circuit assembly into which the device will be installed.

**CAUTION :**

Be sure no power is applied to the chassis or circuit, and observe all other safety precautions.

8. Minimize bodily motions when handling unpackaged replacement ES devices. (Otherwise harmless motion such as the brushing together of your clothes fabric or the lifting of your foot from a carpeted floor can generate static electricity (ESD) sufficient to damage an ES device).

### 2.2. How to Recycle the Lithium Ion Battery (U.S. Only)

**ENGLISH**



A lithium ion battery that is recyclable powers the product you have purchased. Please call 1-800-8-BATTERY for information on how to recycle this battery.

**FRANÇAIS**



L'appareil que vous vous êtes procuré est alimenté par une batterie au lithium-ion recyclable. Pour des renseignements sur le recyclage de la batterie, veuillez composer le 1-800-8-BATTERY.

## 2.3. Caution for AC Cord (For EB/GC)

### 2.3.1. Information for Your Safety

#### IMPORTANT

Your attention is drawn to the fact that recording of pre-recorded tapes or discs or other published or broadcast material may infringe copyright laws.

#### WARNING

To reduce the risk of fire or shock hazard, do not expose this equipment to rain or moisture.

#### CAUTION

To reduce the risk of fire or shock hazard and annoying interference, use the recommended accessories only.

#### FOR YOUR SAFETY

##### DO NOT REMOVE THE OUTER COVER

To prevent electric shock, do not remove the cover. No user serviceable parts inside. Refer servicing to qualified service personnel.

### 2.3.2. Caution for AC Mains Lead

For your safety, please read the following text carefully.

This appliance is supplied with a moulded three-pin mains plug for your safety and convenience.

A 5-ampere fuse is fitted in this plug.

Should the fuse need to be replaced please ensure that the replacement fuse has a rating of 5 amperes and it is approved by ASTA or BSI to BS1362

Check for the ASTA mark or the BSI mark on the body of the fuse.



If the plug contains a removable fuse cover you must ensure that it is refitted when the fuse is replaced.

If you lose the fuse cover, the plug must not be used until a replacement cover is obtained.

A replacement fuse cover can be purchased from your local Panasonic Dealer.

If the fitted moulded plug is unsuitable for the socket outlet in your home then the fuse should be removed and the plug cut off and disposed of safely.

There is a danger of severe electrical shock if the cut off plug is inserted into any 13-ampere socket.

If a new plug is to be fitted please observe the wiring code as shown below.

If in any doubt, please consult a qualified electrician.

### 2.3.2.1. Important

The wires in this mains lead are coloured in accordance with the following code:

Blue	Neutral
Brown	Live

As the colours of the wires in the mains lead of this appliance may not correspond with the coloured markings identifying the terminals in your plug, proceed as follows:

The wire which is coloured BLUE must be connected to the terminal in the plug which is marked with the letter N or coloured BLACK.

The wire which is coloured BROWN must be connected to the terminal in the plug which is marked with the letter L or coloured RED.

Under no circumstances should either of these wires be connected to the earth terminal of the three pin plug, marked with the letter E or the Earth Symbol.

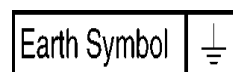

### 2.3.2.2. Before Use

Remove the Connector Cover as follows.

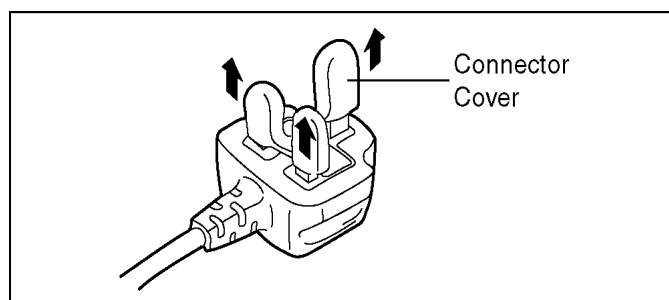

### 2.3.2.3. How to Replace the Fuse

1. Remove the Fuse Cover with a screwdriver.

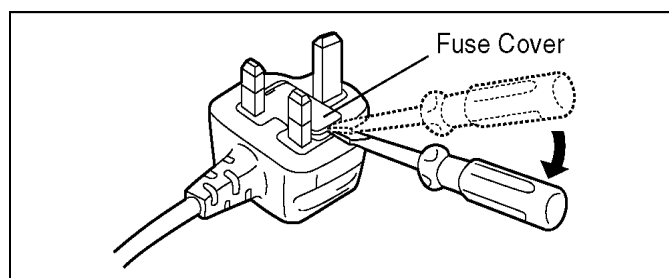

2. Replace the fuse and attach the Fuse cover.

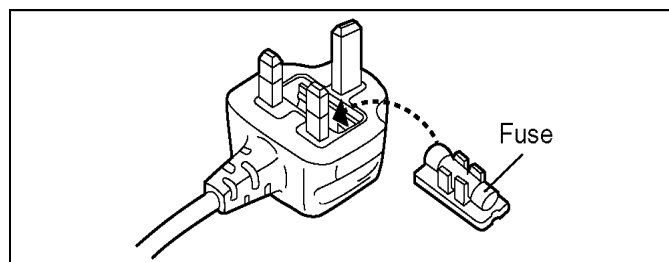

## 2.4. How to Replace the Lithium Battery

### 2.4.1. Replacement Procedure

1. Remove the MAIN P.C.B.. (Refer to Disassembly Procedures.)
2. Remove the Lithium battery (Ref. No. "B9101" at component side of MAIN P.C.B.) and then replace it into new one.

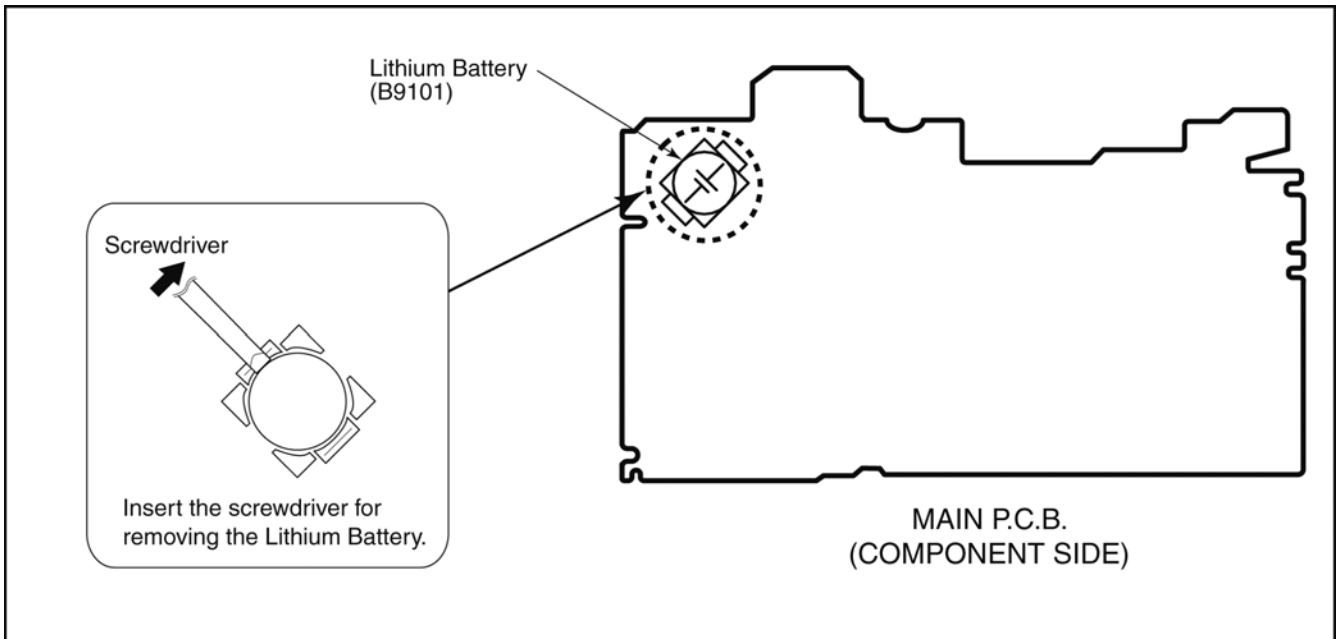

#### NOTE:

This Lithium battery is a critical component.

(Type No.: ML614 **Manufactured by Energy Company, Panasonic Corporation.**)

It must never be subjected to excessive heat or discharge.

It must therefore only be fitted in requirement designed specifically for its use.

Replacement batteries must be of same type and manufacture.

They must be fitted in the same manner and location as the original battery, with the correct polarity contacts observed.

Do not attempt to re-charge the old battery or re-use it for any other purpose.

It should be disposed of in waste products destined for burial rather than incineration.

#### (For English)

### CAUTION

Danger of explosion if battery is incorrectly replaced.

Replace only with the same or equivalent type recommended by the manufacturer.

Dispose of used batteries according to the manufacturer's instructions.

#### (For German)

### ACHTUNG

Explosionsgefahr bei falschem Anbringen der Batterie. Ersetzen Sie nur mit einem äquivalentem vom Hersteller empfohlenem Typ.

Behandeln Sie gebrauchte Batterien nach den Anweisungen des Herstellers.

#### (For French)

### MISE EN GARDE

Une batterie de remplacement inappropriée peut exploser. Ne remplacez qu'avec une batterie identique ou d'un type recommandé par le fabricant. L'élimination des batteries usées doit être faite conformément aux instructions du fabricant.

#### NOTE:

Above caution is applicable for a battery pack which is for DMC-FZ40,FZ45 series, as well.

## 3 Service Navigation

### 3.1. Introduction

This service manual contains technical information, which allow service personnel's to understand and service this model.

Please place orders using the parts list and not the drawing reference numbers.

If the circuit is changed or modified, the information will be followed by service manual to be controlled with original service manual.

### 3.2. General Description About Lead Free Solder (PbF)

The lead free solder has been used in the mounting process of all electrical components on the printed circuit boards used for this equipment in considering the globally environmental conservation.

The normal solder is the alloy of tin (Sn) and lead (Pb). On the other hand, the lead free solder is the alloy mainly consists of tin (Sn), silver (Ag) and Copper (Cu), and the melting point of the lead free solder is higher approx.30°C (86°F) more than that of the normal solder.

#### Distinction of P.C.B. Lead Free Solder being used

The letter of "PbF" is printed either foil side or components side on the P.C.B. using the lead free solder.(See right figure)
--

PbF
-----

#### Service caution for repair work using Lead Free Solder (PbF)

- The lead free solder has to be used when repairing the equipment for which the lead free solder is used.  
(Definition: The letter of "PbF" is printed on the P.C.B. using the lead free solder.)
- To put lead free solder, it should be well molten and mixed with the original lead free solder.
- Remove the remaining lead free solder on the P.C.B. cleanly for soldering of the new IC.
- Since the melting point of the lead free solder is higher than that of the normal lead solder, it takes the longer time to melt the lead free solder.
- Use the soldering iron (more than 70W) equipped with the temperature control after setting the temperature at 350±30°C (662±86°F).

#### Recommended Lead Free Solder (Service Parts Route.)

- The following 3 types of lead free solder are available through the service parts route.
  - RFKZ03D01KS----- (0.3mm 100g Reel)
  - RFKZ06D01KS----- (0.6mm 100g Reel)
  - RFKZ10D01KS----- (1.0mm 100g Reel)

#### Note

\* Ingredient: tin (Sn) 96.5%, silver (Ag) 3.0%, Copper (Cu) 0.5%, Cobalt (Co) / Germanium (Ge) 0.1 to 0.3%

### 3.3. Important Notice 1:(Other than U.S.A. and Canadian Market)

1. The service manual does not contain the following information because of issues servicing to component level without necessary equipment/facilities.
  - a. Schematic diagram, Block Diagram and P.C.B. layout of MAIN P.C.B..
  - b. Parts list for individual parts for MAIN P.C.B..

When a part replacement is required for repairing MAIN P.C.B., replace as an assembled parts. (MAIN P.C.B.)

2. The following category is/are recycle module part. please send it/them to Central Repair Center.
  - MAIN P.C.B. (VEP56113A: P/PC/PR/PU/EE/GC/GK/GN/GT): Excluding replacement of Lithium Battery.
  - MAIN P.C.B. (VEP56113B: EB/EF/EG/EP): Excluding replacement of Lithium Battery.



### 3.4. How to Define the Model Suffix (NTSC or PAL model)







There are nine kinds of DMC-FZ40/FZ45, regardless of the colours.

- a) DMC-FZ40P/PC
- b) DMC-FZ45EB/EF/EG/EP
- c) DMC-FZ45EE
- d) DMC-FZ40GT
- e) DMC-FZ40GK
- f) DMC-FZ40GN
- g) DMC-FZ40GC/PU/PR

What is the difference is that the "INITIAL SETTINGS" data which is stored in Flash-ROM mounted on MAIN P.C.B..

#### 3.4.1. Defining methods:

To define the model suffix to be serviced, refer to the nameplate which is putted on the bottom side of the Unit.

<p><b>a) DMC-FZ40P/PC</b> The nameplate for these models show the following Safety registration mark.</p> 
<p><b>b) DMC-FZ45EB/EF/EG/EP</b> The nameplate for these models show the following Safety registration mark.</p> 
<p><b>c) DMC-FZ45EE</b> The nameplate for this model show the following Safety registration mark.</p> 
<p><b>d) DMC-FZ40GT</b> The nameplate for this model show the following Safety registration mark.</p> 
<p><b>e) DMC-FZ40GK</b> The nameplate for this model show the following Safety registration mark.</p> 
<p><b>f) DMC-FZ45GN</b> The nameplate for this model show the following Safety registration mark.</p> 
<p><b>g) DMC-FZ40GC/PU/PR</b> The nameplate for these models do not show any above Safety registration mark.</p>

**NOTE:**

After replacing the MAIN P.C.B., be sure to achieve adjustment.

The service software is available at "TSN Website". To download, click on "Support Information from NWBG/VDBG-AVC".

### 3.4.2. INITIAL SETTINGS:

After replacing the MAIN P.C.B., be sure to perform the initial settings after achieving the adjustment by ordering the following procedure in accordance with model suffix of the unit.

#### 1. IMPORTANT NOTICE:

Before proceeding Initial settings, be sure to read the following CAUTIONS.

#### **CAUTION 1:(INITIAL SETTINGS)**

---AFTER REPLACING THE MAIN P.C.B. and/or FLASH-ROM ---

[Except "EG, EF, EB and EP" models : (VEP56113A is used as a Main P.C.B.)]

\*.The model suffix can be chosen **JUST ONE TIME.**

(Effective model suffix : " P/PU/GC/GT/GK/EE/GN/PC and PR

\*.Once one of the model suffix has been chosen, the model suffix lists will not be displayed, thus, it can not be changed.

[Only for "EG, EF, EB and EP" models : (VEP56113B is used as a Main P.C.B.)]

\*.From the beginning, only "EG, EF, EB and EP" are displayed as model suffix lists, and these are displayed from the second times as well.

#### **CAUTION 2:(Stored picture image data in the unit)**

This unit employs "Built-in Memory" for picture image data recording.(Approx.40MB)  
After proceeding "INITIAL SETTINGS", the picture image data stored in the unit is erased.

#### 2. PROCEDURES:

• Precautions: Read the above "CAUTION 1" and "CAUTION 2", carefully.

• Preparation:

- Attach the Battery or AC Adaptor with a DC coupler to the unit.

(Since this unit has built-in memory, it can be performed without inserting SD memory card.)

• **Step 1. The temporary cancellation of "INITIAL SETTINGS":**

Set the mode dial to "[ P ] (Program AE mode)".

While keep pressing "[ UP ] of Cursor button" and [ MOTION PICTURE ] button simultaneously, turn the Power on.

• **Step 2. The cancellation of "INITIAL SETTINGS":**

Press the [ PLAYBACK ] button, then playback the picture.

Press "[ UP ] of Cursor button" and [ MOTION PICTURE ] button simultaneously, then turn the Power off.

• **Step 3. Turn the Power on:**

Set the mode dial to "[ P ] (Program AE mode)", and then turn the Power on.

• **Step 4. Display the INITIAL SETTING:**

While keep pressing [ MENU/SET ] and "[ RIGHT ] of Cursor buttons" simultaneously, turn the Power off.

The "INITIAL SETTINGS" menu is displayed.

There are two kinds of "INITIAL SETTINGS" menu form as follows:

[CASE 1. After replacing MAIN P.C.B.]

[Except “EG, EF, EB and EP” models: (VEP56113A is used as a Main P.C.B.)]

When MAIN P.C.B. has just been replaced, all of the model suffix is displayed as follows. (Four pages in total)

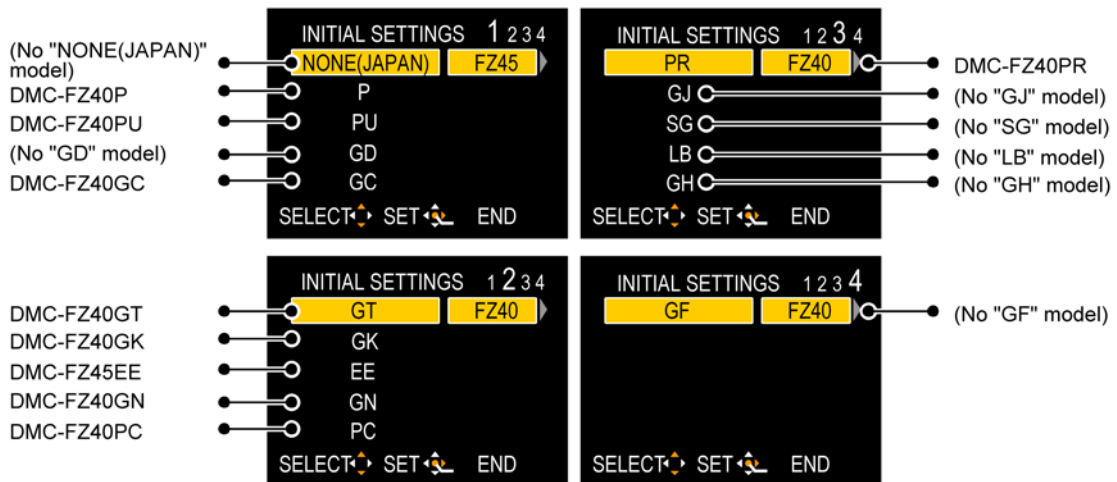

[Only “EG, EF, EB and EP” models: (VEP56113B is used as a Main P.C.B.)]

When MAIN P.C.B. has just been replaced, only 6 model suffix are displayed as follows. (Two pages in total)



[CASE 2. Other than “After replacing MAIN P.C.B.”]



• **Step 5. Choose the model suffix in “INITIAL SETTINGS”:** (Refer to “CAUTION 1”)

[Caution: After replacing MAIN P.C.B.]

The model suffix can be chosen, **JUST ONE TIME.**

Once one of the model suffix have been chosen, the model suffix lists will not be displayed, thus, it can not be changed.

Therefore, select the area carefully.

Select the area with pressing “[ UP ] / [ DOWN ] of Cursor buttons”.

• **Step 6. Set the model suffix in “INITIAL SETTINGS”:**

- Press the “[ RIGHT ] of Cursor buttons”.
- The only set area is displayed, and then press the “[ RIGHT ] of Cursor buttons” after confirmation.  
(The unit is powered off automatically.)

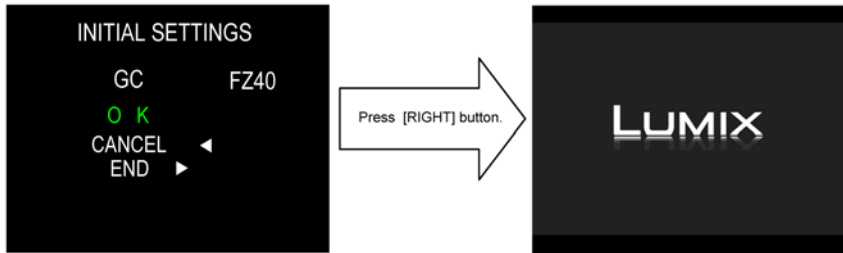

• **Step 7. CONFIRMATION:**

Confirm the display of “PLEASE SET THE CLOCK” in concerned language when the unit is turned on again.  
When the unit is connected to PC with USB cable, it is detected as removable media.  
(When the “GT” or “GK” model suffix is selected, the display shows “PLEASE SET THE CLOCK” in Chinese.)

1) As for your reference, major default setting condition is as shown in the following table.

• **Default setting (After “INITIAL SETTINGS”)**

	MODEL	VIDEO OUTPUT	LANGUAGE	DATE	REMARKS
a)	DMC-FZ40P	NTSC	English	Month/Date/Year	
b)	DMC-FZ40PU	NTSC	Spanish	Month/Date/Year	
c)	DMC-FZ40GC	PAL	English	Date/Month/Year	
d)	DMC-FZ40GT	NTSC	Chinese (traditional)	Year/Month/Date	
e)	DMC-FZ40GK	PAL	Chinese (simplified)	Year/Month/Date	
f)	DMC-FZ45EE	PAL	Russian	Date/Month/Year	
g)	DMC-FZ40GN	PAL	English	Date/Month/Year	
h)	DMC-FZ40PC	NTSC	English	Month/Date/Year	
i)	DMC-FZ40PR	PAL	English	Date/Month/Year	
j)	DMC-FZ45EG	PAL	English	Date/Month/Year	
k)	DMC-FZ45EF	PAL	French	Date/Month/Year	
l)	DMC-FZ45EB	PAL	English	Date/Month/Year	
m)	DMC-FZ45EP	PAL	English	Date/Month/Year	

# 4 Specifications

**Digital Camera:** Information for your safety

<b>Power Source:</b>	DC 8.4 V
<b>Power Consumption:</b>	1.3 W (When recording with LCD Monitor) 1.1 W (When recording with Viewfinder) 0.7 W (When playing back with LCD Monitor) 0.5 W (When playing back with Viewfinder)

**Camera effective pixels:** 14,100,000 pixels

**Image sensor:** 1/2.33" CCD, total pixel number 14,500,000 pixels, Primary color filter

**Lens:** Optical 24× zoom f = 4.5 mm to 108 mm  
35 mm film camera conversion:  
25 mm to 600 mm (4:3),  
27 mm to 654 mm (still pictures 16:9),  
29 mm to 693 mm (motion pictures 16:9),  
26 mm to 624 mm (3:2),  
30 mm to 709 mm (1:1)  
Wide end: F2.8 to F8.0  
(when recording motion pictures: F2.8 to F11)  
Tele end: F5.2 to F8.0  
(when recording motion pictures: F5.2 to F11)

**Digital Zoom:** Max. 4×

**Extended optical zoom:** Max. 50.6×  
(When set to 3,000,000 pixels [3M] or less)

**Focus range:** AF: 30 cm (0.99 feet) (Wide)/2 m (6.57 feet) (Tele) to ∞  
AF Macro/MF/Intelligent Auto:  
1 cm (0.04 feet) (Wide)/1 m (3.28 feet) (Tele) to ∞  
Scene Mode: There may be differences in the above settings.

**Shutter system:** Electronic shutter+Mechanical shutter

**Burst recording**

**Burst speed:** Approx. 1.8 pictures/second

**Number of recordable pictures:** Max. 5 pictures (Standard), Max. 3 pictures (Fine).

**Hi-speed burst**

**Burst speed:** Approx. 10 pictures/second (Speed priority)  
Approx. 6 pictures/second (Image priority)  
[3M (4:3), 2.5M (3:2), 2M (16:9) or 2.5M (1:1) is selected as the picture size.]

**Number of recordable pictures:** Approx. 15 to 100

**Minimum illuminance:** Approx. 6 lx (when i-low light is used)

**Shutter speed**

**Still picture:** 60 seconds to 1/2000th of a second  
[STARRY SKY] Mode: 15 seconds, 30 seconds, 60 seconds

**Motion pictures:** 1/30 to 1/20000th of a second  
Creative Motion Picture Mode  
(Manual Exposure/Manual Focus): 1/8 to 1/20000th of a second

**Exposure (AE):** Program AE (P)/Aperture-Priority AE (A)/Shutter-Priority AE (S)/Manual Exposure (M)  
Exposure compensation (1/3 EV Step, -3 EV to +3 EV)

**Metering mode:** Multiple/Center weighted/Spot

**LCD monitor:** 3.0" TFT LCD (3:2)  
(Approx. 230,000 dots) (field of view ratio about 100%)

**Viewfinder:** Color LCD Viewfinder (Approx. 202,000 dots)  
(field of view ratio about 100%)  
(with diopter adjustment -4 to +4 diopter)

**Flash:** Built-in pop up flash  
Flash range: [ISO AUTO]  
Approx. 30 cm (0.99 feet) to 9.5 m (31.16 feet) (Wide)  
AUTO, AUTO/Red-eye reduction, Forced flash ON  
(Forced ON/Red-eye reduction), Slow sync./Red-eye reduction, Forced flash OFF

**Microphone:** Stereo

**Speaker:** Monaural

**Recording media:** Built-in Memory (Approx. 40 MB)/SD Memory Card/SDHC Memory Card/SDXC Memory Card

**Recording file format**

**Still Picture:** JPEG (based on "Design rule for Camera File system", based on "Exif 2.3" standard)/RAW, DPOF corresponding

**Motion pictures with audio:** AVCHD Lite/QuickTime Motion JPEG

**Interface**

**Digital:** "USB 2.0" (High Speed)

**Analog video/audio:** [for NTSC areas]  
NTSC  
Audio line output (stereo)  
[for PAL areas]  
NTSC/PAL Composite (Switched by menu)  
Audio line output (stereo)

**Terminal**

**[AV OUT/DIGITAL]:** Dedicated jack (14 pin)

**[HDMI]:** MiniHDMI TypeC

**Dimensions:** Approx. 120.3 mm (W)×79.8 mm (H)×91.9 mm (D)  
[4.74" (W)×3.14"(H)×3.62" (D)]  
(excluding the projecting parts)

**Mass (weight):** Approx. 498 g/1.10 lb (with card and battery)  
Approx. 454 g/1.00 lb (excluding card and battery)

**Operating temperature:** 0 °C to 40 °C (32 °F to 104 °F)

**Operating humidity:** 10%RH to 80%RH

**Battery Charger:** Information for your safety

<b>Input:</b>	~ 110 V to 240 V, 50/60 Hz, 0.15 A
<b>Output:</b>	== 8.4 V, 0.43 A

**Equipment mobility:** Movable

**Battery Pack (lithium-ion):** Information for your safety

<b>Voltage/capacity:</b>	7.2 V/895 mAh
--------------------------	---------------

**NOTE:(Only for "EB/EF/EG/EP" models)**

- Data from the PC can not be written to the camera using the USB connection cable.

**Motion pictures**

- (Only "EB/EF/EG/EP" models:)
- Motion pictures can be recorded continuously for up to 29 minutes 59 seconds.
- (Except "EB/EF/EG/EP" models:)
- Motion picture recorded continuously in [MOTION JPEG] or [HIGH SPEED MOVIE] in Scene Mode is up to 2 GB. Only the maximum recordable time for 2 GB is displayed on the screen.

# 5 Location of Controls and Components

## Names of the Components

- 1 Lens
- 2 Flash
- 3 Self-Timer indicator  
AF assist lamp
- 4 Lens hood attachment part

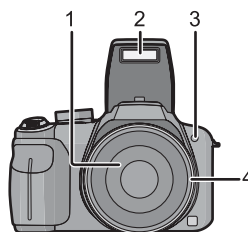

- 5 [Q.MENU] button/Delete button
- 6 [DISPLAY] button
- 7 [AF/AF-ON/MF] button
- 8 LCD monitor
- 9 Flash open button
- 10 Diopter adjustment dial
- 11 Viewfinder
- 12 [EVF/LCD] button
- 13 [AF/AE LOCK] button
- 14 Rear dial
- 15 Playback button
- 16 [MENU/SET] button
- 17 Cursor buttons

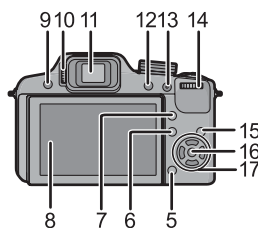

- ◀ Self-Timer button
- ▼ Function button  
Assign [REC] Mode menu to ▼ button. It is convenient to register [REC] Mode menu that is used often.  
[ASPECT RATIO]/[QUALITY]/[METERING MODE]/[WHITE BALANCE]/  
[I.EXPOSURE]/[COLOR EFFECT]/[GUIDE LINE]/[RECORD AREA]/  
[REMAINING DISP.]
- ▶ ISO
- ▲ Exposure compensation/  
Auto Bracket/Flash output adjustment

- 18 Stereo microphone
- 19 Zoom lever
- 20 Shutter button
- 21 Motion picture button
- 22 [FOCUS] button
- 23 Power lamp
- 24 Camera ON/OFF switch
- 25 Mode dial

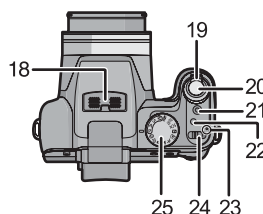

- 26 Shoulder strap eyelet
- 27 [HDMI] socket
- 28 [AV OUT/DIGITAL] socket
- 29 Terminal door

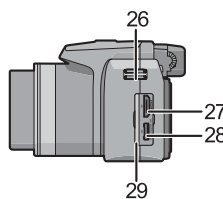

- 30 Speaker
- 31 Lens barrel

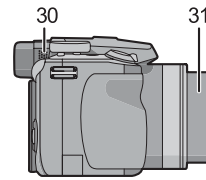

- 32 Release lever
- 33 Tripod receptacle
  - When you use a tripod, make sure the tripod is stable when the camera is attached to it.
- 34 Card/Battery door
- 35 DC coupler cover
  - When using an AC adaptor, ensure that the Panasonic DC coupler and AC adaptor are used.
  - Always use a genuine Panasonic AC adaptor.
  - We recommend you use a battery with sufficient battery power or the AC adaptor when recording motion pictures.
  - If while recording motion pictures using the AC adaptor and the power supply is cut off due to a power outage or if the AC adaptor is disconnected etc., the motion picture being recorded will not be recorded.

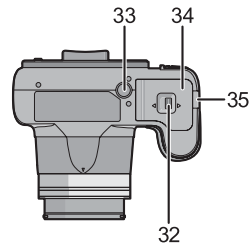

## Selecting the [REC] Mode

### 1 Turn the camera on.

- The power lamp 2 lights when you turn this unit on 1.

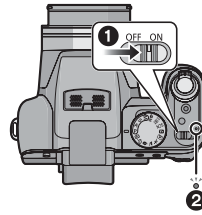

### 2 Switching the mode by rotating the mode dial.

- Align a desired mode with part A.
- Rotate the mode dial slowly and surely to adjust to each mode. (The mode dial rotates 360°)



#### Basic

##### **iA** Intelligent Auto Mode

The subjects are recorded using settings automatically selected by the camera.

##### **P** Program AE Mode

The subjects are recorded using your own settings.

#### Advanced

##### **A** Aperture-Priority AE Mode

The shutter speed is automatically determined by the aperture value you set.

##### **S** Shutter-Priority AE Mode

The aperture value is automatically determined by the shutter speed you set.

##### **M** Manual Exposure Mode

The exposure is adjusted by the aperture value and the shutter speed which are manually adjusted.

##### **CM** Creative Motion Picture Mode

Record motion picture with manual settings.

##### **CUST** Custom Mode

Use this mode to take pictures with previously registered settings.

##### **SCN** Scene Mode

This allows you to take pictures that match the scene being recorded.

##### **My Color Mode**

Use this mode to check coloring effects, select a color mode from among twelve color modes, and then take pictures.

#### Advanced Scene Mode

##### **Portrait Mode**

Use this mode to take pictures of people.

##### **Scenery Mode**

Use this mode to take pictures of scenery.

##### **Sports Mode**

Use this mode to take pictures of sporting events, etc.

##### **Close-up Mode**

Use this mode to take close-up pictures of a subject.

##### **\* Night Portrait Mode**

Use this mode to take pictures of night scenes and people against night time scenery.



## About the Battery

- The camera has a function for distinguishing batteries which can be used safely. The dedicated battery supports this function. The only batteries suitable for use with this unit are genuine Panasonic products and batteries manufactured by other companies and certified by Panasonic. (Batteries which do not support this function cannot be used). Panasonic cannot in any way guarantee the quality, performance or safety of batteries which have been manufactured by other companies and are not genuine Panasonic products.

It has been found that counterfeit battery packs which look very similar to the genuine product are made available to purchase in some markets. Some of these battery packs are not adequately protected with internal protection to meet the requirements of appropriate safety standards. There is a possibility that these battery packs may lead to fire or explosion. Please be advised that we are not liable for any accident or failure occurring as a result of use of a counterfeit battery pack. To ensure that safe products are used we would recommend that a genuine Panasonic battery pack is used.

# 6 Service Mode

## 6.1. Error Code Memory Function

### 1. General description

This unit is equipped with history of error code memory function, and can be memorized 16 error codes in sequence from the latest. When the error is occurred more than 16, the oldest error is overwritten in sequence.

The error code is not memorized when the power supply is shut down forcibly (i.e., when the unit is powered on by the battery, the battery is pulled out) The error code is memorized to FLASH-ROM when the unit has just before powered off.

### 2. How to display

The error code can be displayed by ordering the following procedure:

#### • Preparation:

1. Attach the Battery or AC Adaptor with a DC coupler to the unit.

#### NOTE:

\*Since this unit has built-in memory, it can be performed without inserting SD memory card.

#### • Step 1. The temporary cancellation of "INITIAL SETTINGS":

Set the mode dial to "[ P ] (Program AE mode)".

While keep pressing "[ UP ] of Cursor button" and [ MOTION PICTURE ] button simultaneously, turn the Power on.

#### • Step 2. Execute the error code display mode:

Press the "[ LEFT ] of Cursor button", [ MENU/SET ] button and [ MOTION PICTURE ] button simultaneously.

The display is changed as shown below when the above buttons are pressed simultaneously.

Normal display → Error code display → Operation history display → Normal display → .....

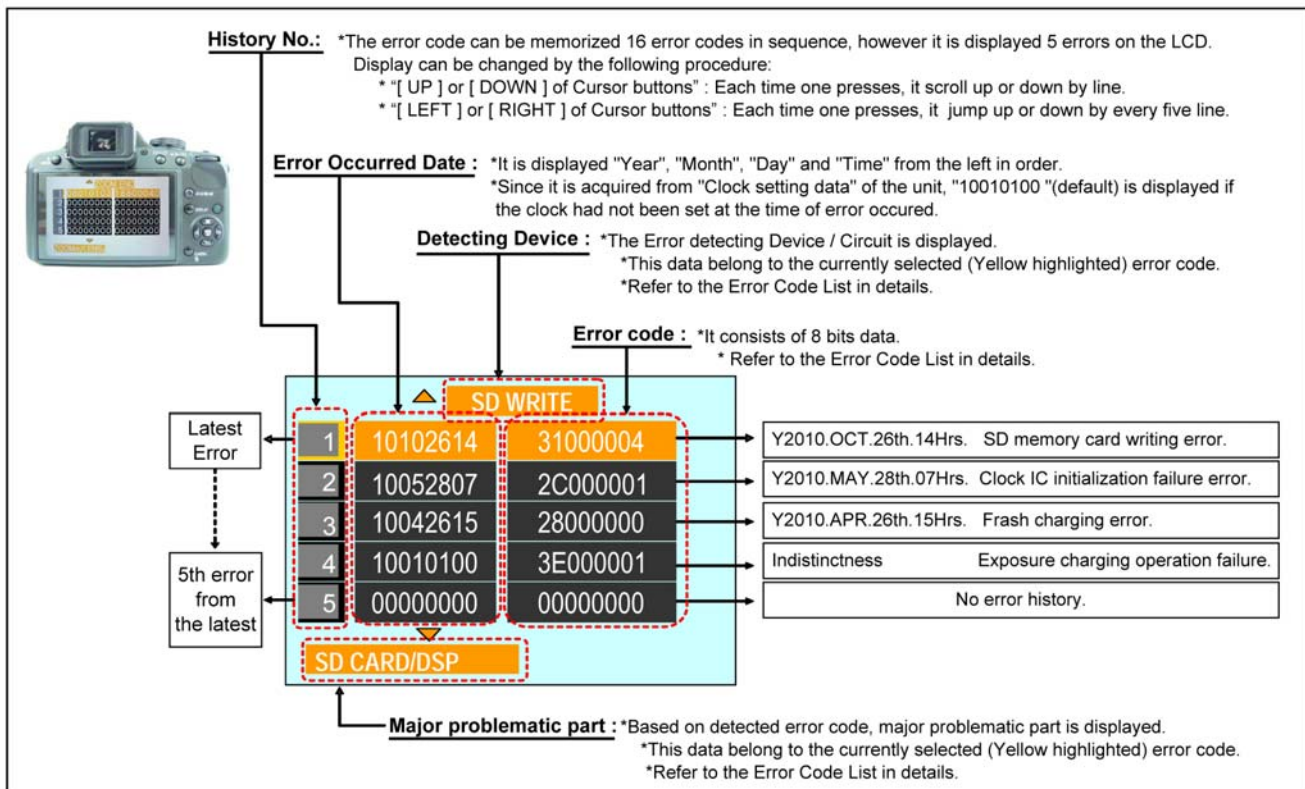

Example of Error Code Display

• 3. Error Code List

The error code consists of 8 bits data and it shows the following information.

Attribute	Main item	Sub item	Error code		Contents (Upper line)		Error Indication						
			High 4 bits	Low 4 bits	Problematic Part & Check point (Lower line)		Detecting device	Problematic Part/Circuit					
LENS	Lens drive	OIS	18*0	1000	PSD (X) error. Hall element (X axis) position detect error in OIS unit.	OIS Unit	OIS X	LENSu NG					
				2000	PSD (Y) error. Hall element (Y axis) position detect error in OIS unit.	OIS Unit	OIS Y						
			3000	GYRO (X) error. Gyro (IC7102: X axis) detect error on MAIN P.C.B.	IC7102 (Gyro element) or IC6001 (VENUS HD2)	GYRO X	GYRO NG						
				4000	GYRO (Y) error. Gyro (IC7101: Y axis) detect error on MAIN P.C.B.	IC7101 (Gyro element) or IC6001 (VENUS HD2)		GYRO Y					
			5000	MREF error (Reference voltage error).	IC9101 (SYSTEM) or IC6001 (VENUS HD2)	OIS REF	LENSsd/DSP NG						
				6000	Drive voltage (X) error.	LENS Unit, LENS flex breaks, IC6001 (VENUS HD2) AD value error, etc.		OISX REF					
			7000	Drive voltage (Y) error.	LENS Unit, LENS flex breaks, IC6001 (VENUS HD2) AD value error, etc.	OISY REF	LENSu/LENS FPC						
				Zoom	0710	Collapsible barrel Low detect error		(Collapsible barrel encoder always detects Low.)	Mechanical lock, FP9005-(15) signal line or IC6001 (VENUS HD2)	ZOOM L	ZOOMm/LENSu		
			0720			Collapsible barrel High detect error	(Collapsible barrel encoder always detects High.)	Mechanical lock, FP9005-(15) signal line or IC6001 (VENUS HD2)	ZOOM H				
					0730	Zoom motor sensor error.	Mechanical lock, FP9005-(1), (3) signal line or IC6001 (VENUS HD2)	ZOOM ENC					
		0740	Zoom motor sensor error. (During monitor mode.)			Mechanical lock, FP9005-(1), (3) signal line or IC6001 (VENUS HD2)							
			0750			Zoom motor sensor error. (During monitor mode with slow speed.)	Mechanical lock, FP9005-(1), (3) signal line or IC6001 (VENUS HD2)						
		Focus	0701		HP High detect error	(Focus encoder always detects High, and not becomes Low)	Mechanical lock, FP9005-(12) signal line or IC6001 (VENUS HD2)	FOCUS L	LENS FPC/DSP				
					0702	HP Low detect error	(Focus encoder always detects Low, and not becomes High)	Mechanical lock, FP9005-(12) signal line or IC6001 (VENUS HD2)		FOCUS H			
		Lens	18*1	0000	Power ON time out error.	LENS drive system	LENS DRV	LENSu					
					18*2	0000			Power OFF time out error.	LENS drive system			
		Adj. History	OIS	19*0	2000	OIS adj. Yaw direction amplitude error (small)	OIS ADJ	OIS ADJ					
					3000	OIS adj. Pitch direction amplitude error (small)							
					4000	OIS adj. Yaw direction amplitude error (large)							
					5000	OIS adj. Pitch direction amplitude error (large)							
	6000				OIS adj. MREF error								
	7000				OIS adj. time out error								
	8000				OIS adj. Yaw direction off set error								
	9000				OIS adj. Pitch direction off set error								
	A000				OIS adj. Yaw direction gain error								
	B000				OIS adj. Pitch direction gain error								
C000	OIS adj. Yaw direction position sensor error												
D000	OIS adj. Pitch direction position sensor error												
E000	OIS adj. other error												
HARD	VENUS A/D				Flash	28*0			0000	Flash charging error.	IC6001-(AC16) signal line or Flash charging circuit	STRB CHG	STRB PCB/FPC
	FLASH ROM (EEPROM Area)				FLASH ROM (EEPROM Area)	2B*0			0001	EEPROM read error	IC6001 (VENUS HD2)	FROM RE	FROM
		0002	EEPROM write error	IC6001 (VENUS HD2)			FROM WR	FROM					
		0005	Firmware version up error	Replace the firmware file in the SD memory card.			(No indication)	(No indication)					
		0008	SDRAM error	SDRAM Mounting defective									
	SYSTEM	RTC	2C*0	0001	SYSTEM IC initialize failure error	Communication between IC6001 (VENUS HD2) and IC9101 (SYSTEM)	SYS INIT	MAIN PCB					
					SOFT	CPU	Reset	30*0	0001	NMI reset	NMI RST	MAIN PCB	
0007	Non Mask-able Interrupt (30000001-30000007 are caused by factors)												
Card	Card	31*0	0001	Card logic error		SD memory card data line or IC6001 (VENUS HD2)	SD CARD	SD CARD/DSP					
				0002		Card physical error			SD memory card data line or IC6001 (VENUS HD2)				
			0004	Write error		SD memory card data line or IC6001 (VENUS HD2)	SD WRITE						
				39*0		0005	Format error		INMEMORY	FROM			
CPU, ASIC hard	Stop	38*0	0001	Camera task finish process time out.		Communication between Lens system and IC6001 (VENUS HD2)	LENS COM	LENSu/DSP					
				0002	Camera task invalid code error.	IC6001 (VENUS HD2)							
			0100	File time out error in recording motion image	IC6001 (VENUS HD2)	DSP	DSP						
				0200	File data cue send error in recording motion image			IC6001 (VENUS HD2)					
			Memory area	3A*0	0008	USB work area partitioning failure	USB dynamic memory securing failure when connecting	(No indication)	(No indication)				
						Operation	Power on	3B*0	0000	FLASHROM processing early period of camera during movement.	INIT	(No indication)	
Zoom	Zoom	3C*0	0000	Inperfect zoom lens processing	Zoom lens	ZOOM	ZOOMm/LENSu						
				35*0	0000	Software error (0-7bit : command, 8-15bit : status)	DSP	DSP					
		35*1	0000		Though record preprocessing is necessary, it is not called.	(No indication)			(No indication)				
		35*2	0000	Though record preprocessing is necessary, it is not completed.									

### Important notice about "Error Code List"

#### 1) About "\*" indication:

The third digit from the left is different as follows.

- In case of 0 (example: 18001000)

When the third digit from the left shows "0", this error occurred under the condition of INITIAL SETTINGS has been completed.

It means that this error is occurred basically at user side.

- In case of 8 (example: 18801000)

When the third digit from the left shows "8", this error occurred under the condition of INITIAL SETTINGS has been released.

(Example; Factory assembling-line before unit shipment, Service mode etc.)

It means that this error is occurred at service side.

#### 2) About "?" indication: ("18\*0 0?01" to "18\*0 0?50"):

The third digit from the right shows one of the hexadecimal ("0" to "F") character.

#### • 4. How to exit from Error Code display mode:

Simply, turn the power off. (Since Error code display mode is executed under the condition of temporary cancellation of "INITIAL SETTINGS", it wake up with normal condition when turn off the power.)

##### NOTE:

The error code can not be initialized.

## 6.2. ICS (Indication of additional Camera Settings when picture was taken) function

### 1. General description

This unit is equipped with ICS (ICS: Indication of additional Camera Settings when picture was taken) function by playing back the concerned picture on the LCD display.

(This function is achieved by utilizing "maker note" data stored in Exif data area of recorded picture file.)

To proceed failure diagnosis, use this ICS function together with "displaying the recorded picture with picture information" function.

##### NOTE:

- The ICS function operates with a picture which is only taken with the same model. (It may not be displayed when the picture was taken with other model.)
- Since Exif data is not available after the picture is edited by PC, the ICS function may not be activated.

### 2. How to display

The ICS data is displayed by ordering the following procedure:

#### • Preparation:

1. Attach the Battery or AC Adaptor with a DC coupler to the unit.

##### NOTE:

Since this unit has built-in memory, it can be performed without inserting SD memory card.

#### • Step 1. The temporary cancellation of "INITIAL SETTINGS":

Set the mode dial to "[ P ] (Program AE mode)".

While keep pressing "[ UP ] of Cursor button" and [ MOTION PICTURE ] button simultaneously, turn the Power on.

#### • Step 2. Execute the ICS display mode:

Press the [ PLAYBACK ] button, then playback the picture.

Press the "[ LEFT ] of Cursor button", [ MENU/SET ] button and [ MOTION PICTURE ] button simultaneously.

Press the [ DISPLAY ] button, 3 times.

The display condition is changed as shown below when the [ DISPLAY ] button is pressed.

Code display → Code + Picture display (1) → Code + Picture display (2) → ICS display → Code display .....

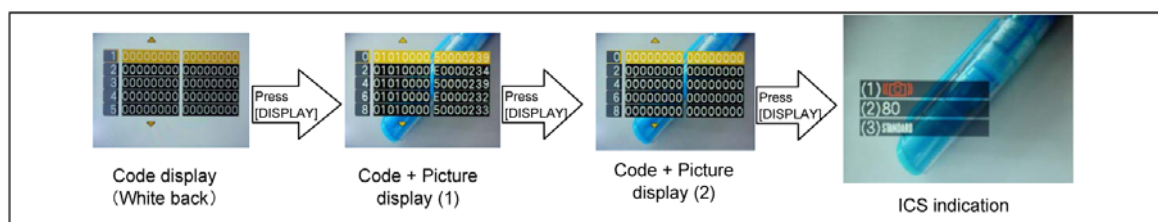

### 3. How to read

**(1). Jitter alert was displayed or not:**  
 This part shows that the "Jitter alert" mark was displayed or not when the picture has just before been taken.  
 +.With "Jitter alert" mark : The "Jitter alert" mark was displayed.  
 +.Without "Jitter alert" mark: The "Jitter alert" mark was not displayed.  
 [About "Jitter alert" mark]  
 Due to lacking the enough light amount etc, shooting condition prone to make a "hand jitter", the "Jitter alert" mark is displayed.  
 [Reference Guide]  
 (Applicable settings : Normal picture mode, ISO100, WIDE edge, Flash OFF)  
 +.The "Jitter alert" mark is displayed when the shutter speed is 1/15th and below.

**(2). ISO Sensitivity Setting condition:**  
 This part shows that the "ISO Sensitivity" setting condition when the picture had been taken.  
 (Note: The [i ISO] is displayed when the "Intelligent ISO" was selected.)  
 For instance, when the recorded picture information shows [ISO100], it can be confirmed the ISO setting condition : [AUTO], [INTELLIGENT ISO] or [ISO 100](Fixed: set by user).  
 [Point for Confirmation]  
 \*The symptom is "Picture with "hand jitter". Subject is not clearly stopped." in darker scene, does the picture was taken with lower ISO setting mode?  
 \*The symptom is "Noisy picture. Rough picture image" in brighter scene, does the picture was taken with higher ISO setting mode?

**(3). Color mode Setting condition:**  
 This part shows that the "Color mode" setting condition when the picture had been taken.  
 [Point for Confirmation]  
 \*The symptom is "Color is strange. The picture is bluish (Yellowish) ", does the picture was taken with [SEPIA] / [COOL] / [WARM] settings?  
 NOTE: As for the symptom related with the color, confirm the picture information which is displayed in normal playback screen as well.  
 (In normal playback screen, the setting condition of "White balance" and "WB Adjustment "can be confirmed.)

Normal playback screen  
(Recorded picture with information)



\*In playback mode, the picture information is displayed when pressing the [DISPLAY] button (It can be confirmed at user as well.)  
 \*Use this indication together with ICS function

[ICS display (Sample)]

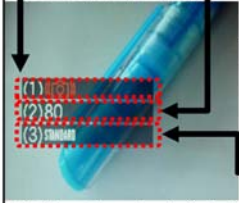

(1). Jitter alert mark : [Indicated]  
 (2). ISO sens. setting : i ISO  
 (3). Color mode setting: Standard

[Reference Guide : Settings "When taking picture"]

**<ISO SENSITIVITY>**  
 \*This allows the sensitivity to light (ISO sensitivity) to be set. Setting to a higher figure enables pictures to be taken even in dark places without the resulting pictures coming out dark.  
 \*In this unit, it can be set one of the [AUTO], [i ISO], [100], [200], [400], [800] and [1600] in "Normal shooting" mode.  
 \*When setting to [AUTO], the ISO sensitivity is automatically adjusted to a maximum of [ISO400] according to the brightness.  
 \*When setting to [iISO], ISO sensitivity will adjust automatically depending on brightness within the maximum setting of [ISO1600]. ([ISO800] when the flash is used)  
 \*ISO sensitivity will operate as [AUTO] in Motion Picture Recording other than Creative Motion Picture. Also, [ISO LIMIT SET] will not function.  
 \*To avoid picture noise, we recommend that you either reduce the ISO sensitivity level or set [COLOR MODE] to [NATURAL], and then take pictures.

ISO sensitivity	100 ← → 1600	
Recording location (recommended)	When it is light (outdoors)	When it is dark
Shutter speed	Slow	Fast
Noise	Less	Increased

ISO sensitivity	Settings
AUTO*	The ISO sensitivity is automatically adjusted according to the brightness.
<i>i</i> ISO* (Intelligent)	The ISO sensitivity is adjusted according to the movement of the subject and the brightness.
100/200/400/800/1600	The ISO sensitivity is fixed to various settings.



### 4. How to exit:

Simply, turn the power off. (Since ICS function is executed under the condition of temporary cancellation of "INITIAL SETTINGS", it wake up with normal condition when turn off the power.)

# 7 Service Fixture & Tools

## 7.1. Service Fixture and Tools

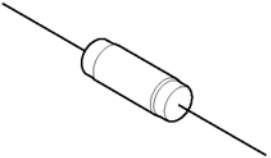
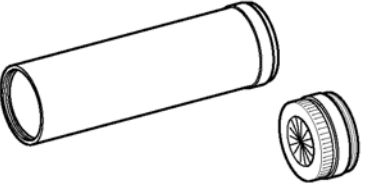
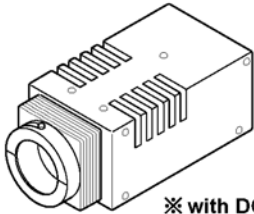
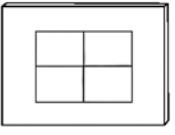
The following Service Fixture and tools are used for checking and servicing this unit.

<b>Resistor for Discharging</b> <b>ERG5SJ102</b>	<b>Infinity Lens (with Focus Chart)</b> <b>RFKZ0422</b>	<b>LIGHT BOX</b> <b>RFKZ0523</b>
 <p>An equivalent type of Resistor may be used.</p>		 <p>※ with DC Cable          * VFK1164TDVLB can be used.</p>
<b>TR Chart</b> <b>RFKZ0443</b>	<b>Lens Cleaning Kit (BK)</b> <b>VFK1900BK</b>	<b>Grease (for lens)</b> <b>RFKZ0472</b>
	 <p>* Only supplied as 10 set/box.</p>	

## 7.2. When Replacing the Main P.C.B.

After replacing the MAIN P.C.B., be sure to achieve adjustment.

The service software is available at "TSN Website". To download, click on "Support Information from NWBG/VDBG-AVC".

## 7.3. Service Position

This Service Position is used for checking and replacing parts. Use the following Extension cables for servicing.

Table S1 Extension Cable List

No.	Parts No.	Connection	Form
1	VFK1906	PS9001 (MAIN) - PP8001 (FLASH)	20PIN B to B
2	VFK1953	FP9005 (MAIN) - LENS UNIT	40PIN 0.5 FFC

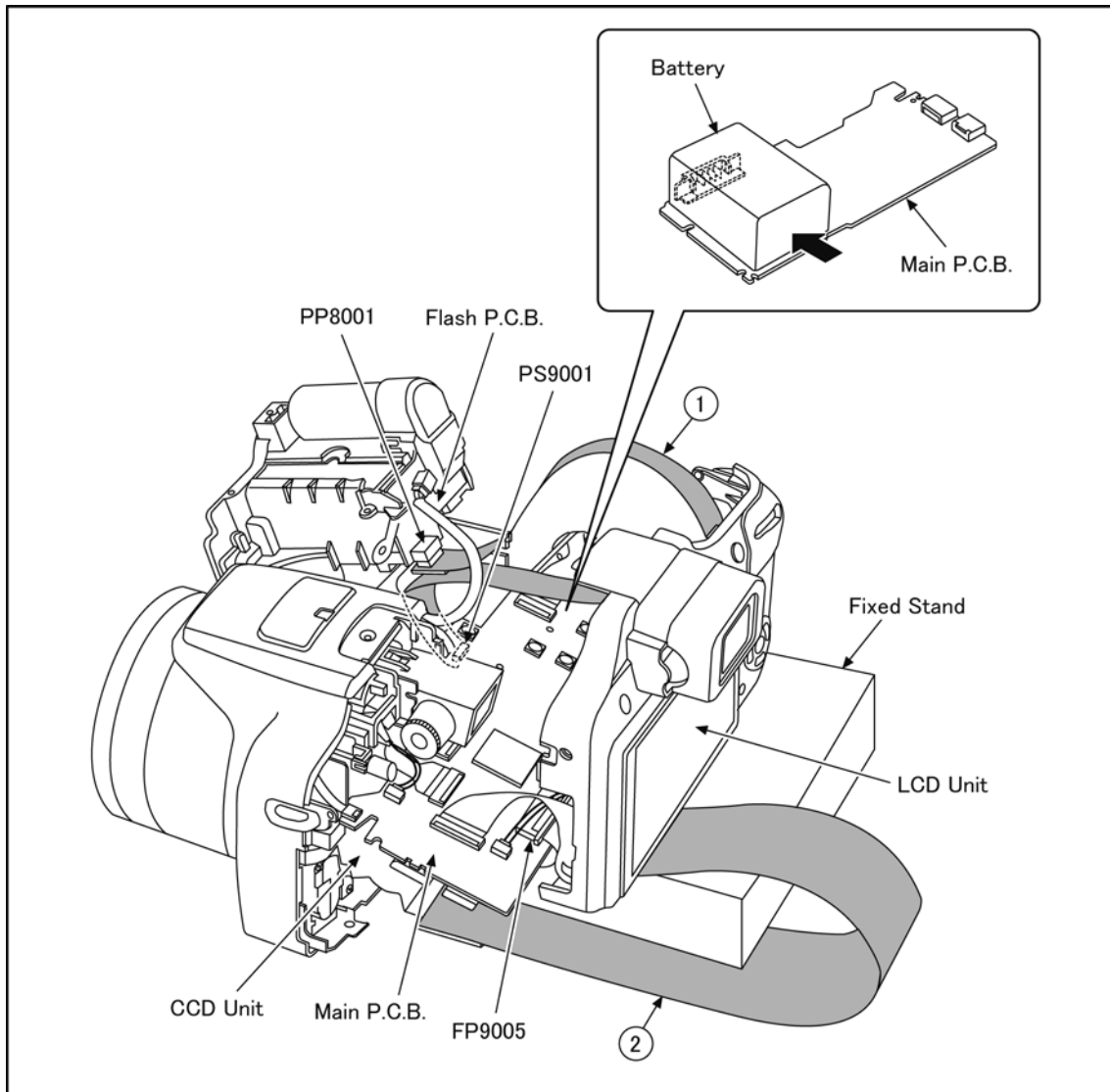

### CAUTION-1. (When servicing FLASH P.C.B.)

1. Be sure to discharge the E.capacitor on FLASH P.C.B..  
Refer to "HOW TO DISCHARGE THE E.CAPACITOR ON FLASH P.C.B.".  
The E.capacitor voltage is not lowered soon even if the AC Cord is unplugged or the battery is removed.
2. Be careful of the high voltage circuit on FLASH P.C.B..
3. DO NOT allow other parts to touch the high voltage circuit on FLASH P.C.B..

# 8 Disassembly and Assembly Instructions

## 8.1. Disassembly Flow Chart

This is a disassembling chart.

When assembling, perform this chart conversely.

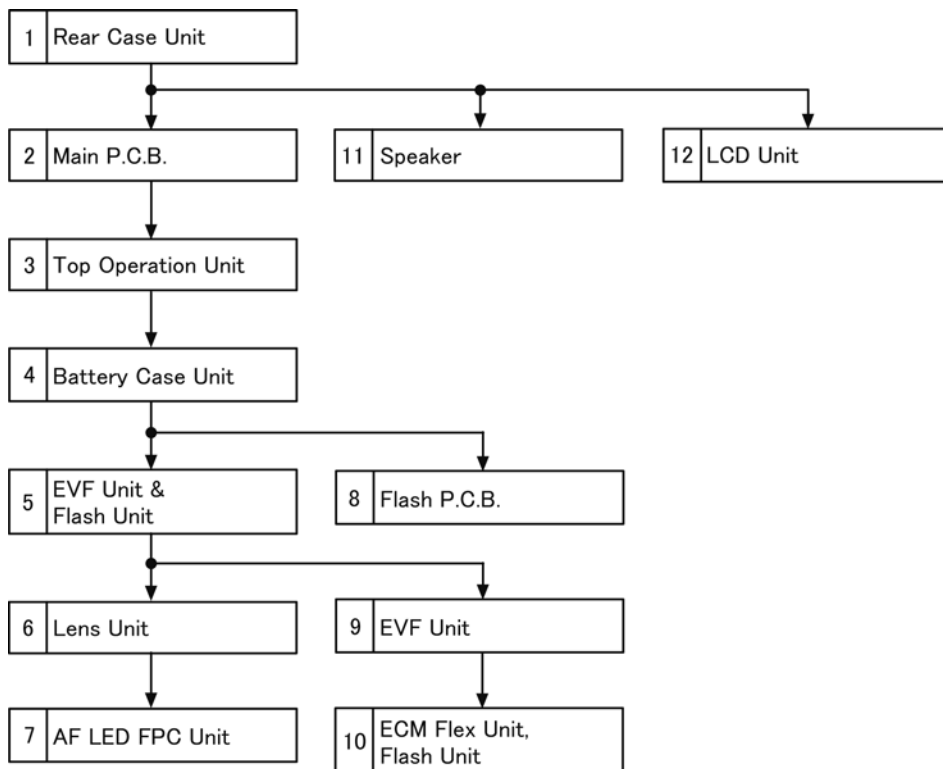

## 8.2. P.C.B. Location

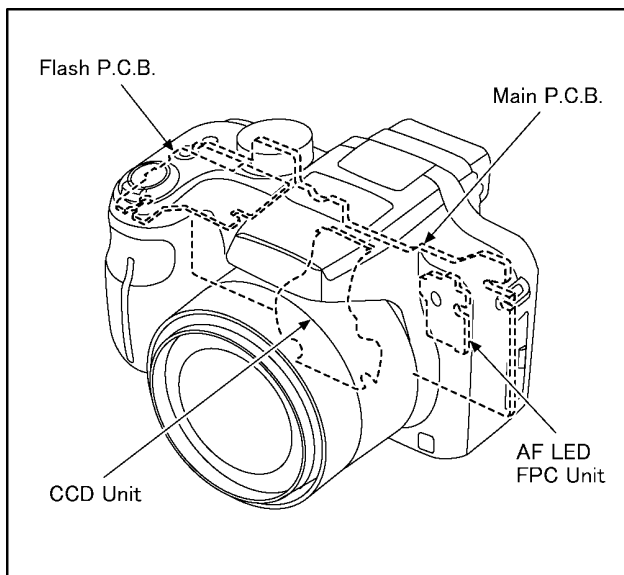



### 8.3. Disassembly Procedure

No.	Item	Fig	Removal			
1	Rear Case Unit	(Fig. D1)	Card			
			Battery			
			3 Screws (A)			
			3 Screws (B)			
		(Fig. D2)	P9001(Connector) FP9003(Flex) Rear Case Unit			
2	Main P.C.B.	(Fig. D3)	1 Screw (C)			
			3 Screws (D)			
			FP9001(Flex)			
			FP9002(Flex)			
			FP9004(Flex)			
			FP9005(Flex)			
			FP9006(Flex)			
			FP9010(Flex)			
			FP9011(Flex)			
			P9005(Connector)			
			(Fig. D4)	PS9001(Connector) Jack Holder Main P.C.B.		
			3	Top Operation Unit	(Fig. D5)	1 Screw (E) Top Operation Unit
		4			Battery Case Unit	(Fig. D6)
5	EVF Unit & Flash Unit		(Fig. D7)	1 Screw (G) EVF Unit & Flash Unit		
		6	Lens Unit	(Fig. D8)	2 Screws (H) Lens Unit	
7	AF LED FPC Unit			(Fig. D9)	1 Screw (I) Strap Holder 1 Locking tab Side Frame (R) Jack Cover	
		(Fig. D10)	1 Screw (J) AF Light Case AF LED FPC Unit			
		8	Flash P.C.B.		(Fig. D11)	1 Locking tab Condensor Cover
					(Fig. D12)	1 Screw (K) 2 Hanging parts Flash P.C.B.
				9	EVF Unit	(Fig. D13)
10	ECM Flex Unit Flash Unit	(Fig. D14)	2 Screws (L)			
		(Fig. D15)	4 Locking tabs Flash Case Top Unit Flash Shaft Flash Pop Up Spring			
			(Fig. D16)	2 Locking tabs Flash Unit MIC Damper MIC Cushion ECM Flex Unit		
			11	Speaker	(Fig. D17)	Wire Fix Tape 1 Screw (M)
					(Fig. D18)	Speaker Fix Plate Speaker
12	LCD Unit	(Fig. D19)	1 Screw (N) 2 Locking tabs LCD Holder LCD Unit			

### 8.3.1. Removal of the Rear Case Unit

**NOTE:**

When servicing and reassembling, remove the card and battery from the unit.

- Card
- Battery
- Screw(A) × 3
- Screw(B) × 3

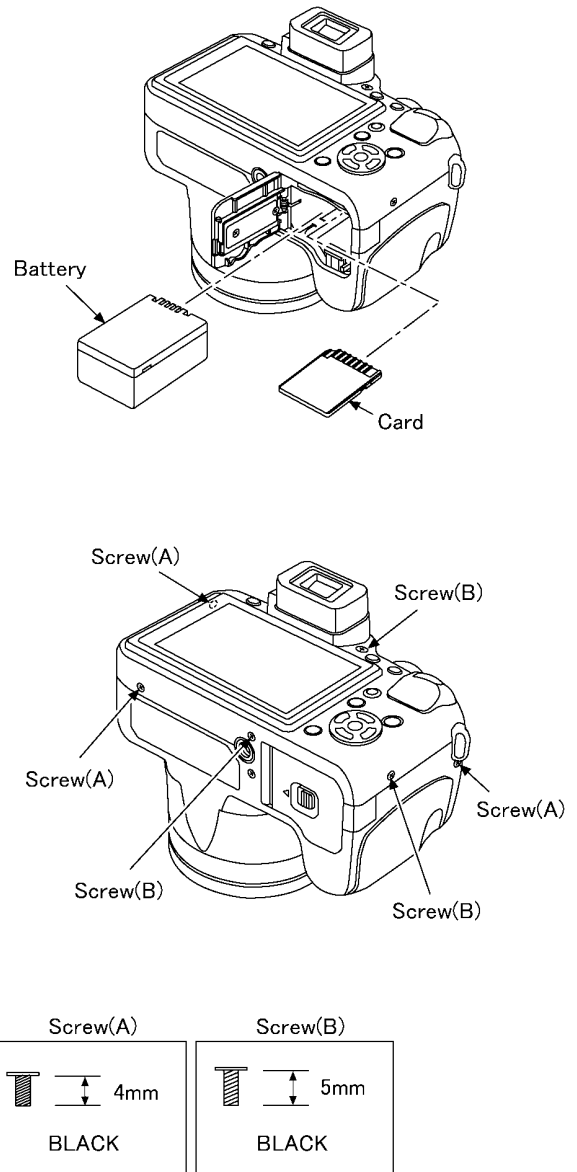

(Fig. D1)

### 8.3.2. Removal of the Main P.C.B.

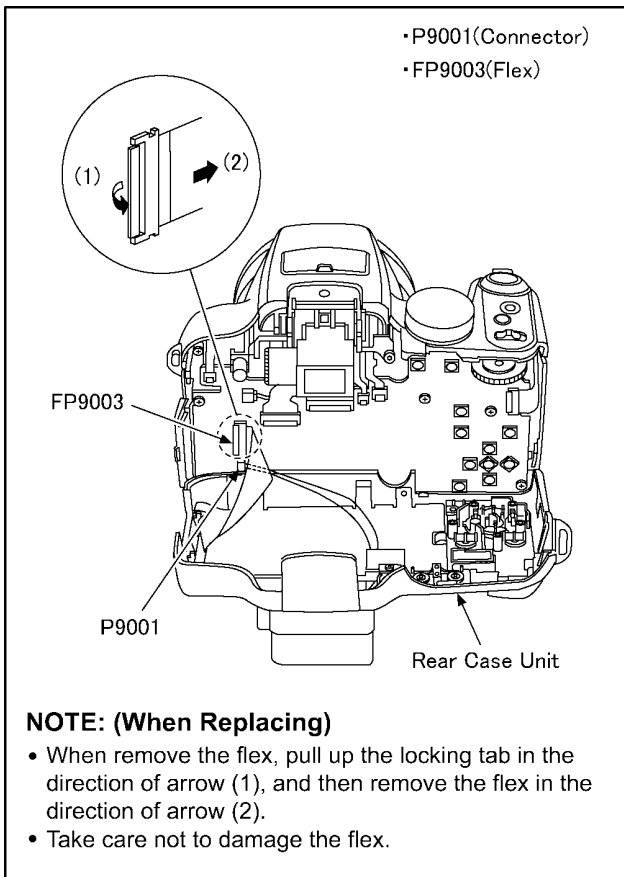

(Fig. D2)

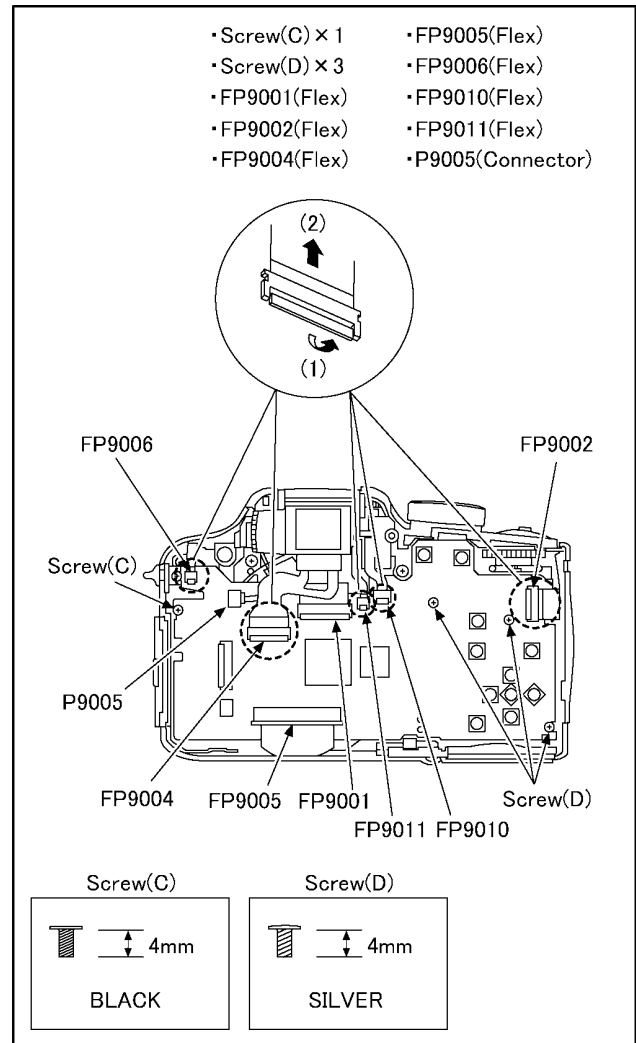

(Fig. D3)

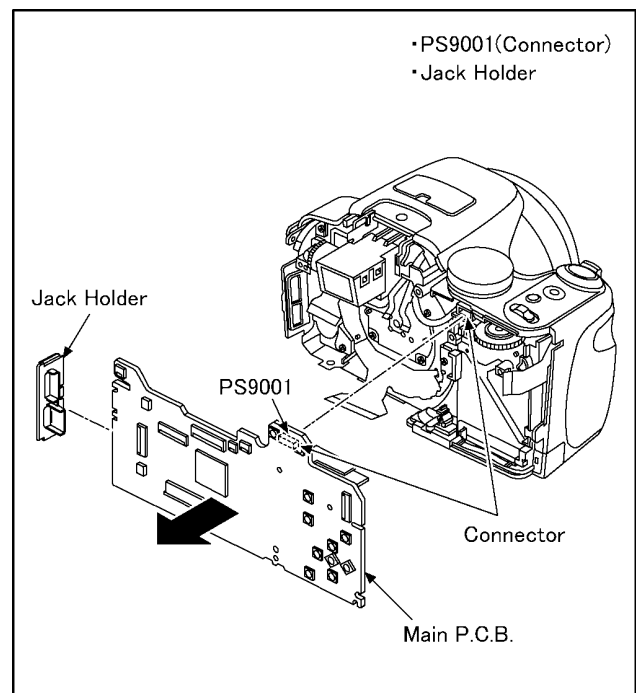

(Fig. D4)

### 8.3.3. Removal of the Top Operation Unit

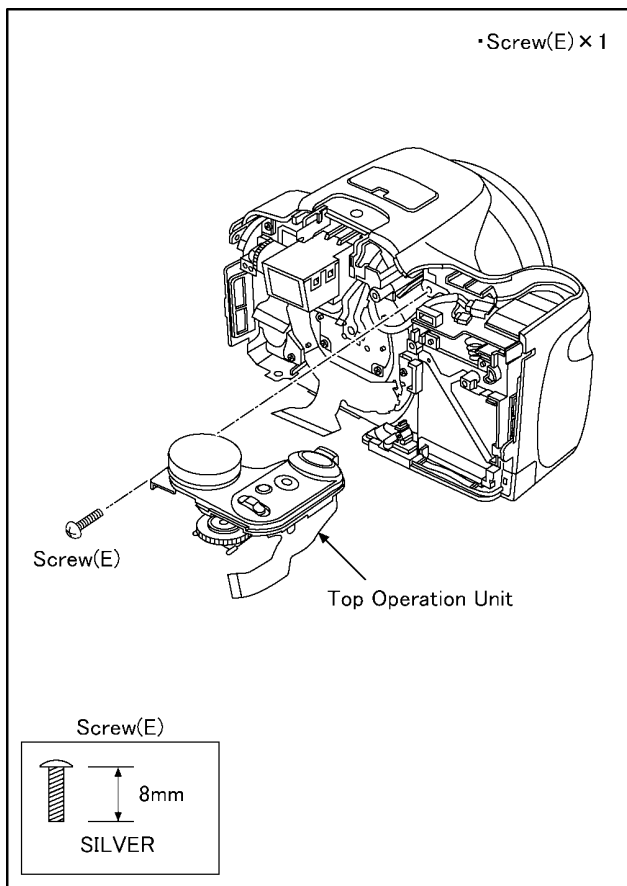

(Fig. D5)

### 8.3.4. Removal of the Battery Case Unit

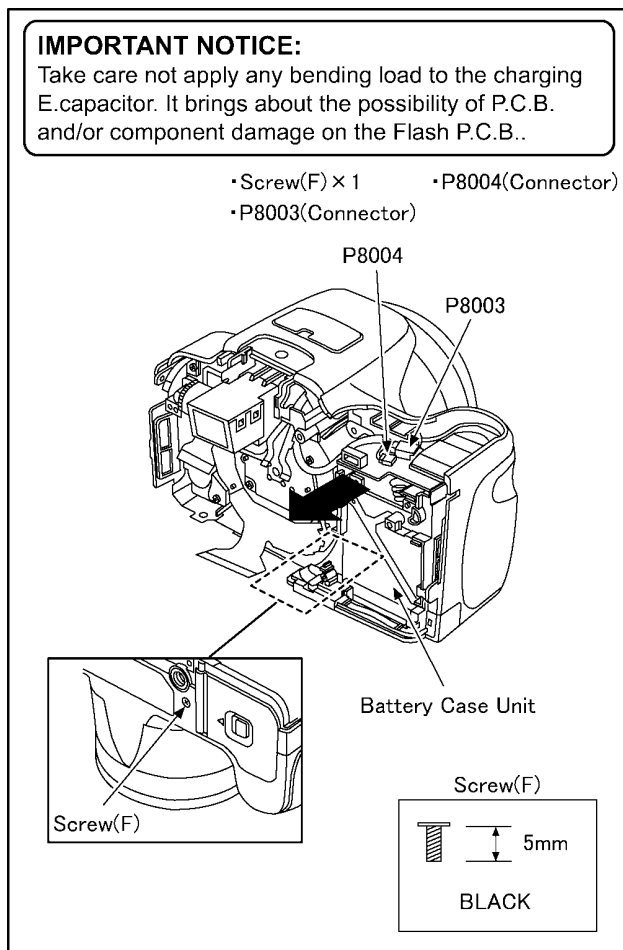

(Fig. D6)

### 8.3.5. Removal of the EVF Unit & Flash Unit

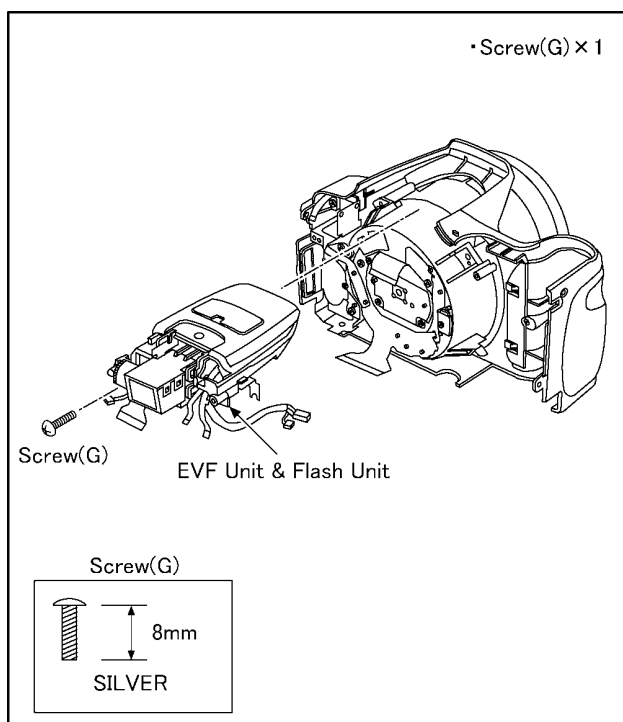

(Fig. D7)

### 8.3.6. Removal of the Lens Unit

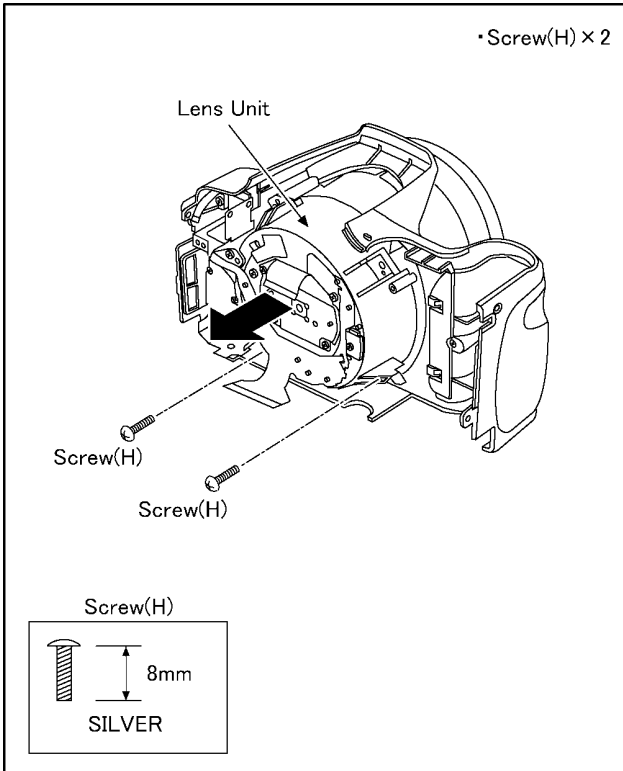

(Fig. D8)

### 8.3.7. Removal of the AF LED FPC Unit

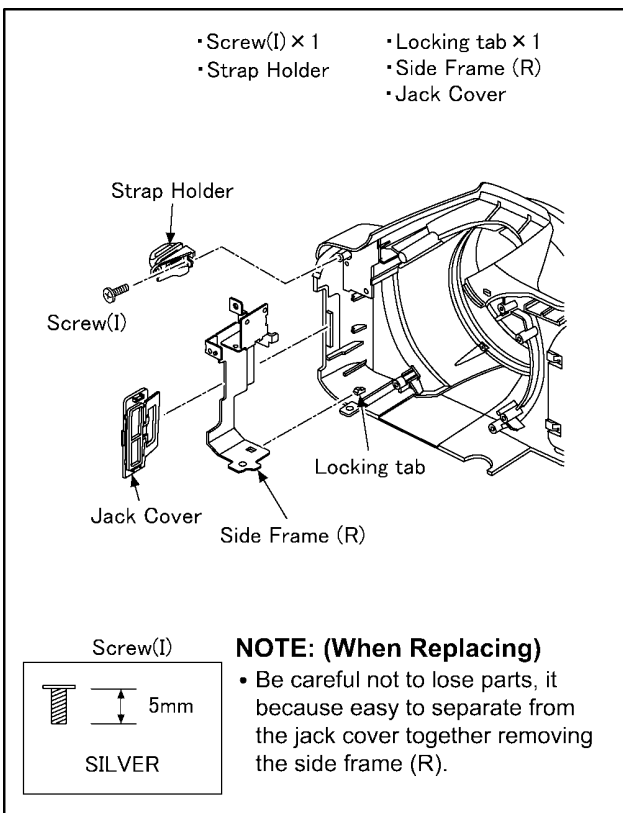

(Fig. D9)

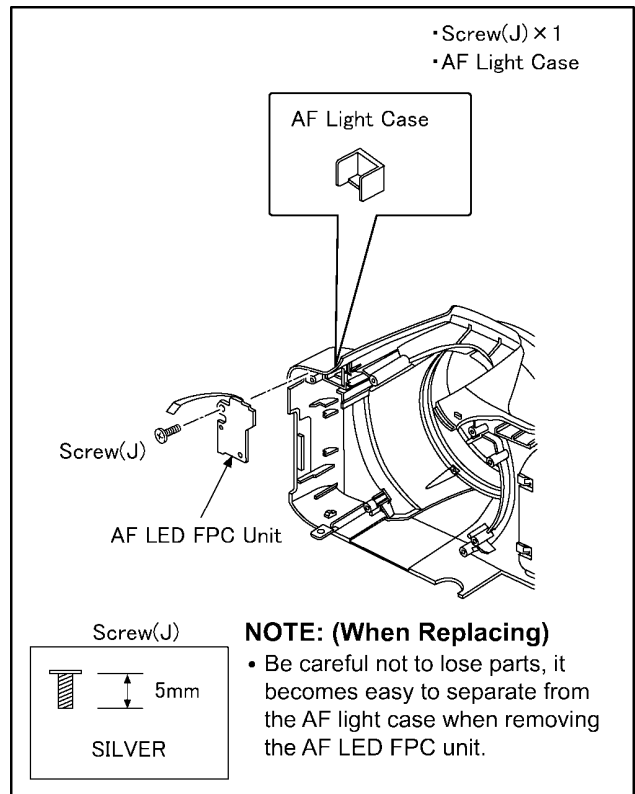

(Fig. D10)

### 8.3.8. Removal of the Flash P.C.B.

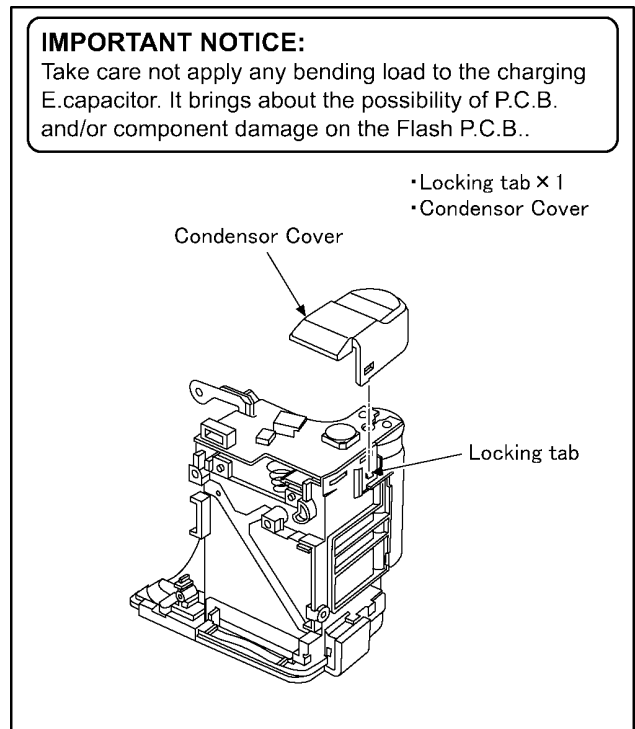

(Fig. D11)

**IMPORTANT NOTICE:**

Take care not apply any bending load to the charging E.capacitor. It brings about the possibility of P.C.B. and/or component damage on the Flash P.C.B..

- Screw(K) × 1
- Hanging part × 2

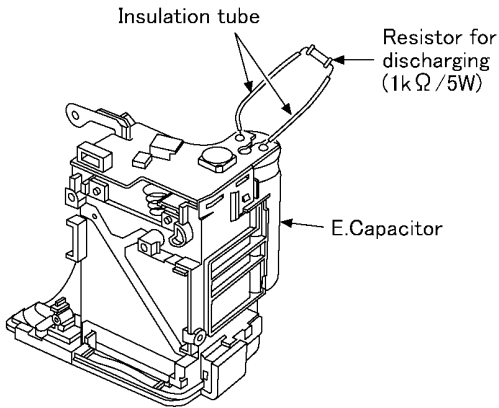

**CAUTION**

Be sure to discharge the E.capacitor on Flash P.C.B. before disassembling.

1. Put the insulation tube on the lead part of resistor (ERG5SJ102:1kΩ/5W).
2. Put the resistor between both terminals of E.capacitor unit for approx. 5 seconds.

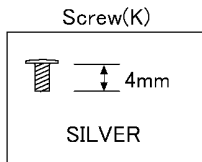
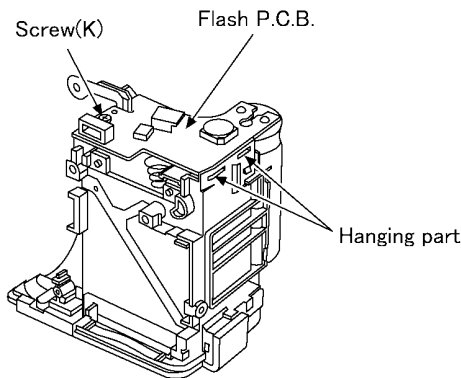

(Fig. D12)

### 8.3.9. Removal of the EVF Unit

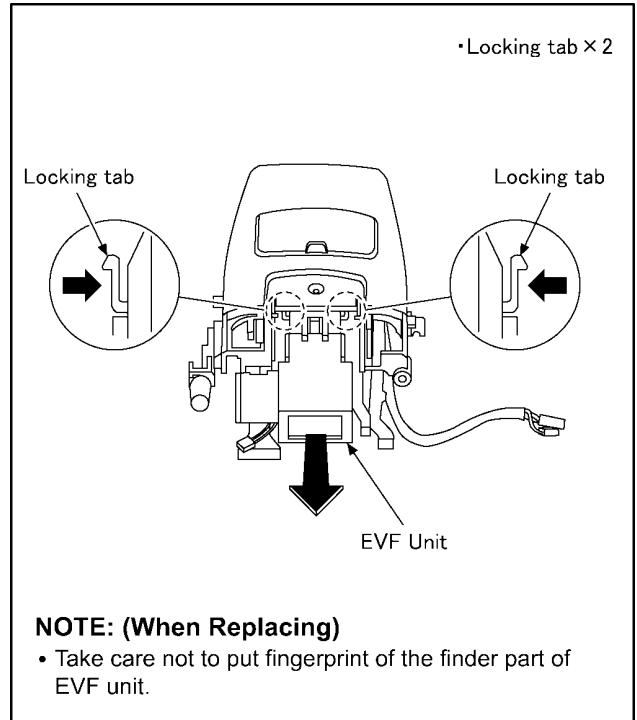

(Fig. D13)

### 8.3.10. Removal of the ECM Flex Unit and Flash Unit

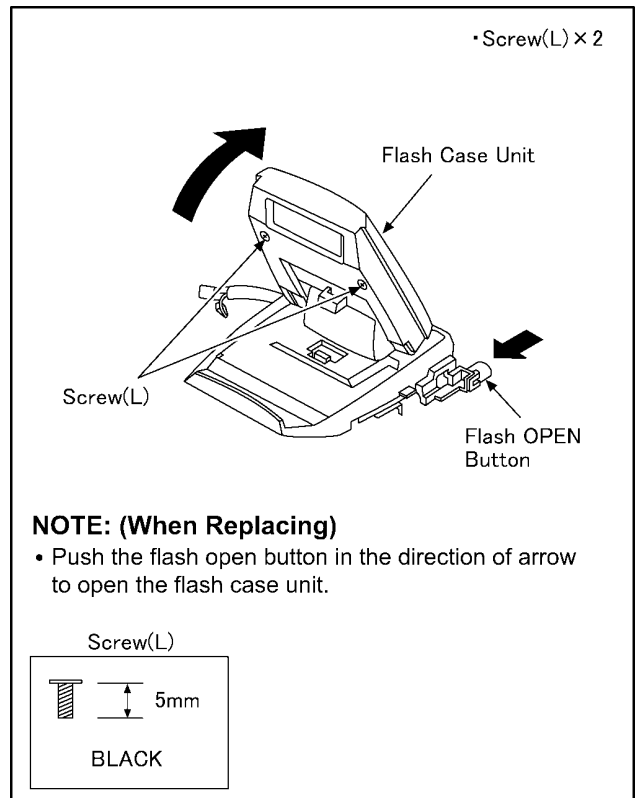

(Fig. D14)

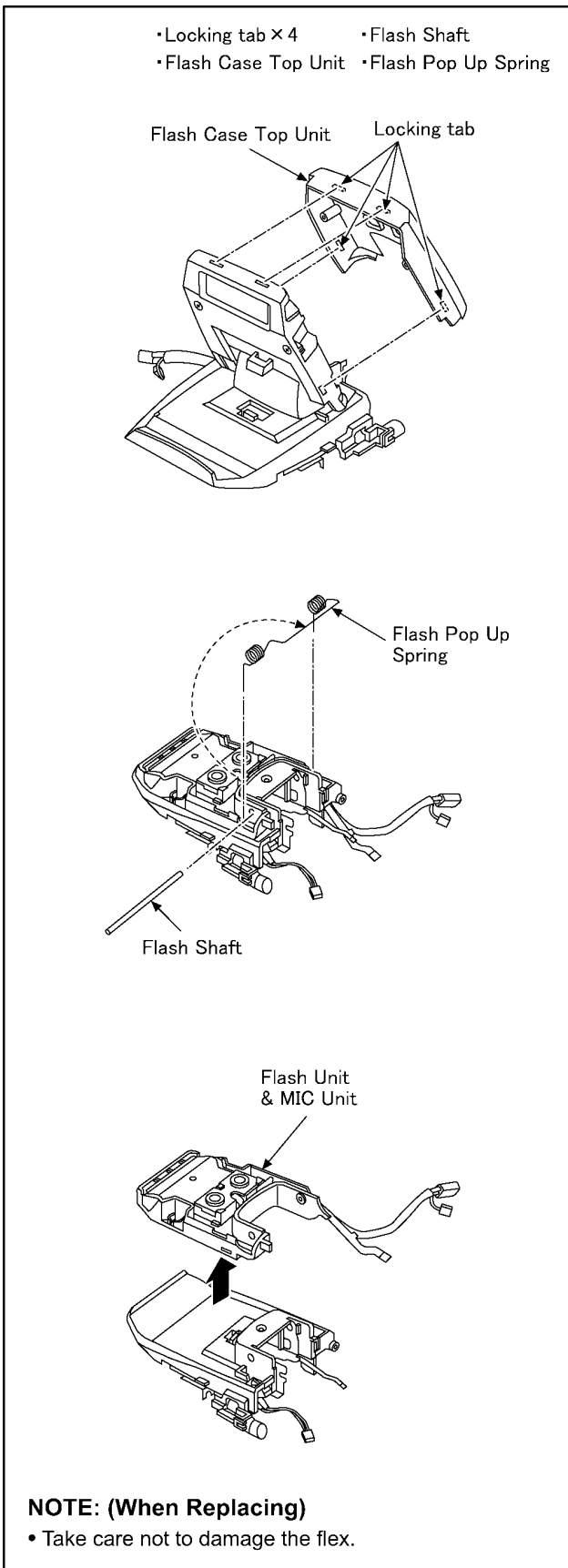

(Fig. D15)

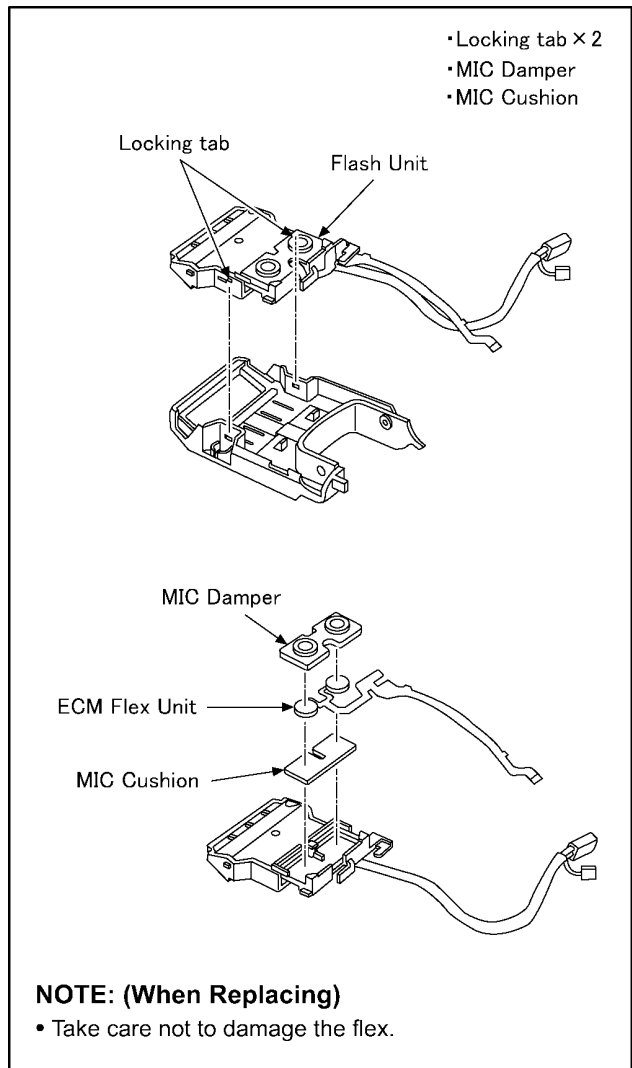

(Fig. D16)

### 8.3.11. Removal of the Speaker

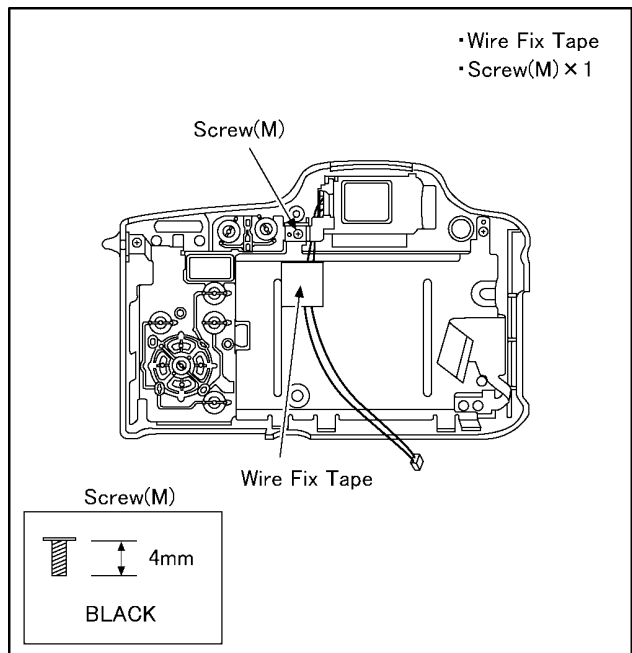

(Fig. D17)

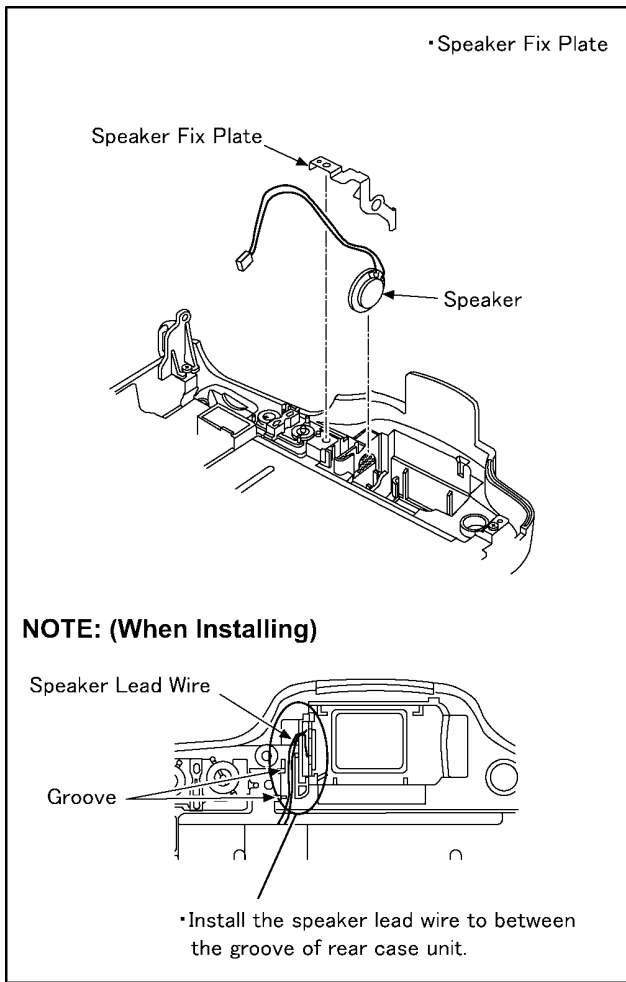

(Fig. D18)

### 8.3.12. Removal of the LCD Unit

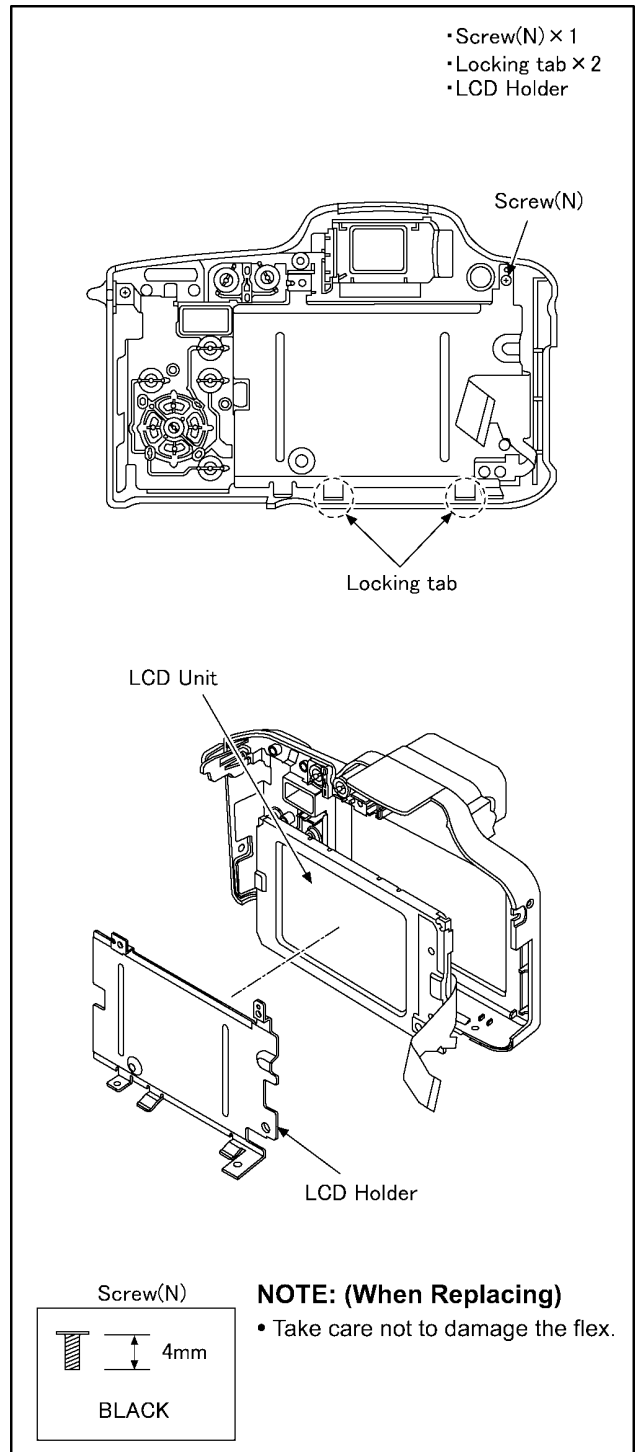

(Fig. D19)

#### **NOTE: (When Installing)**

- Make sure to confirm the following points when installing:
- The Screw is tightened enough.
  - Installing conditions are fine. (No distortion, no abnormal-space.)
  - No dust and/or dirt on Lens surfaces.
  - LCD image is fine. (No dust and dirt on it, and no gradient images.)

## 8.4. Lens Disassembly Procedure

### Precaution:

1. Do not remove the CCD unit when disassembling or re-assembling the lens in order to maintain it clean.  
When remove it, refer to item "8.5."
2. Keep dust or dirt away from the lens.  
To remove dirt or dust from the lens, blow with dry air.
3. Do not touch the lens surface.
4. Use lens cleaning KIT (VFK1900BK).
5. Apply grease as shown on item "8.4.5" and "8.4.6" in the figure.

### 8.4.1. Removal of the Zoom Motor Unit

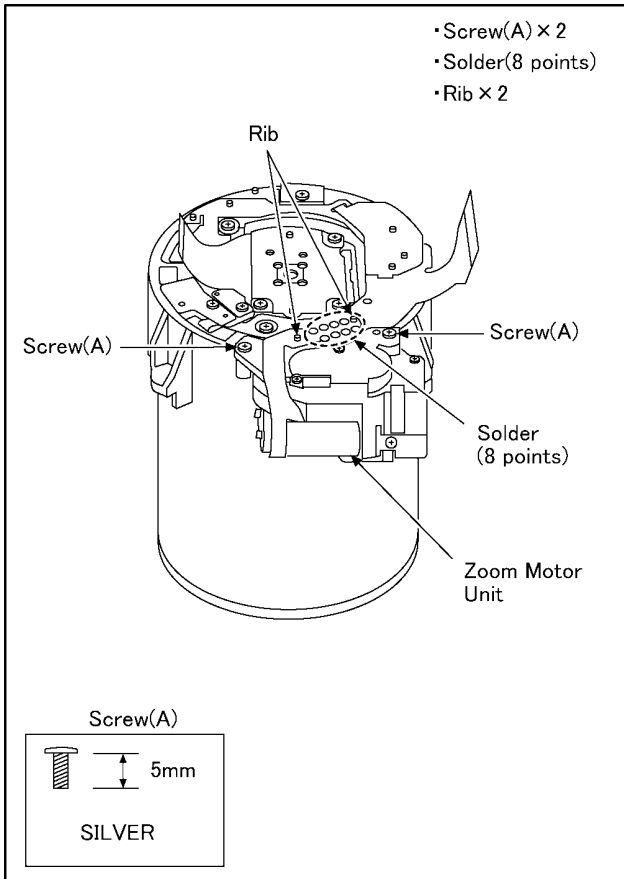

### 8.4.2. Removal of the 1st Lens Frame Unit and 2nd Lens Frame Unit

1. Unscrew the 1 screw (B).
2. Remove the cam stopper.

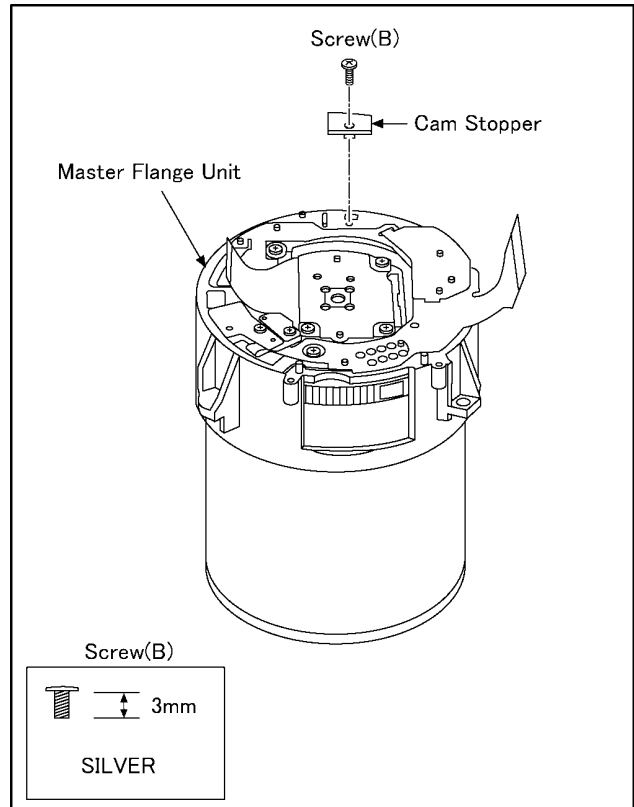



- Turn the cam frame unit or gear part of cam frame unit in the direction of arrow fully.
- Remove the 1st lens frame unit and 2nd lens frame unit.

**CAUTION**

- When remove and install, set the 1st lens frame unit at the upper side at all times, or there is the danger that the 2nd lens frame unit falls and be damaged.

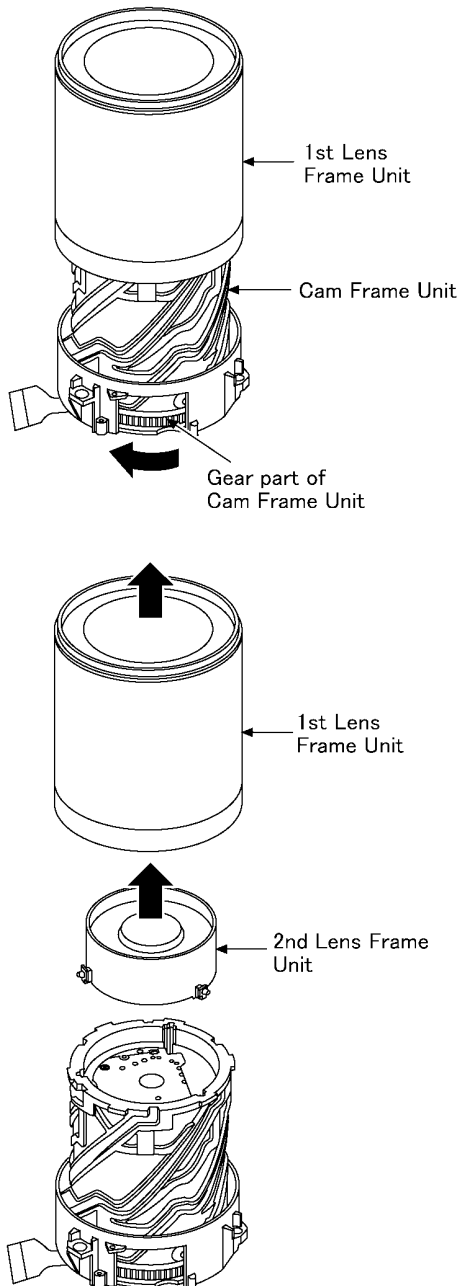

**NOTE: (When Replacing)**

- When lift the 1st lens frame unit and the 2nd lens frame unit, take care not to put fingerprint of the lens.

**NOTE: (When Installing)**

- Align the phase of the groove of middle frame unit and the groove of cam frame unit (3 points).
- Align the  $\Delta$  mark of 2nd lens frame unit and the  $\Delta$  mark of cam frame unit, and then install them.

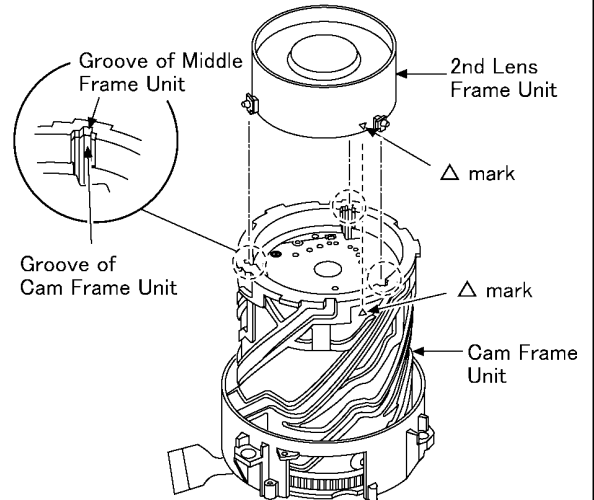

- Align the groove (small) of 1st lens frame unit and the projection part (small) of middle frame unit, and then install them.

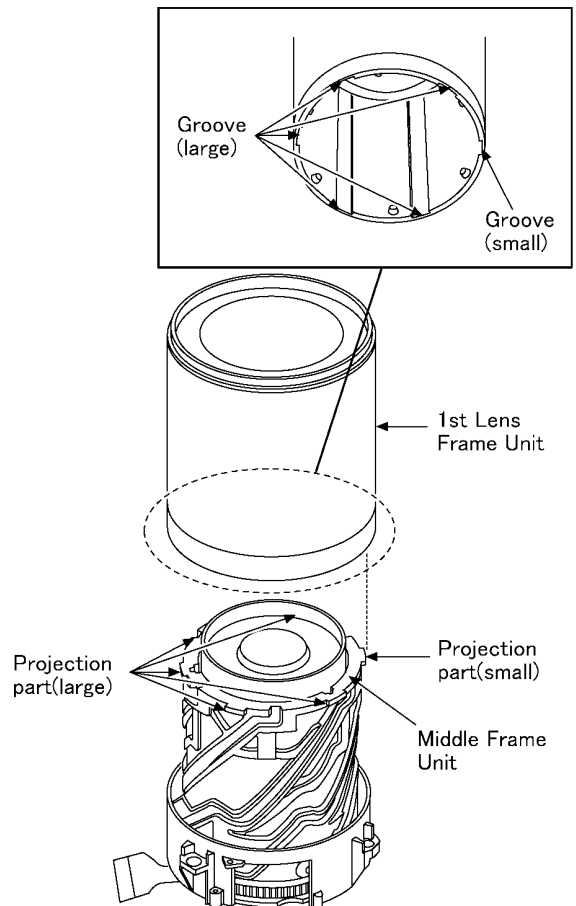

### 8.4.3. Removal of the Master Flange Unit

1. Remove the flex from the connector.
2. Detach the flex from 1 rib of master flange unit.
3. Remove the 4 solders.
4. Unscrew the 3 screws (C).
5. Remove the master flange unit in the direction of arrow.

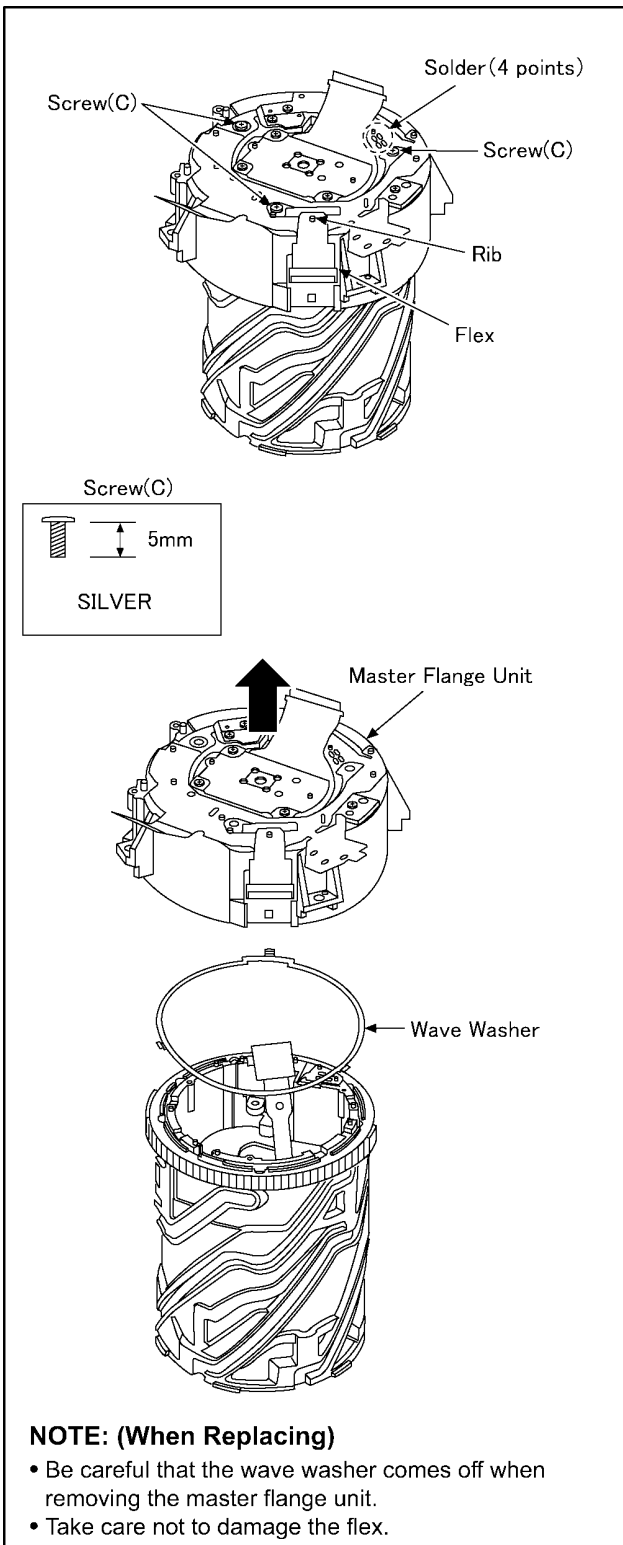

### NOTE: (When Installing)

1. Install the wave washer to the master flange unit with aligning the groove of master flange unit as shown in the figure below.

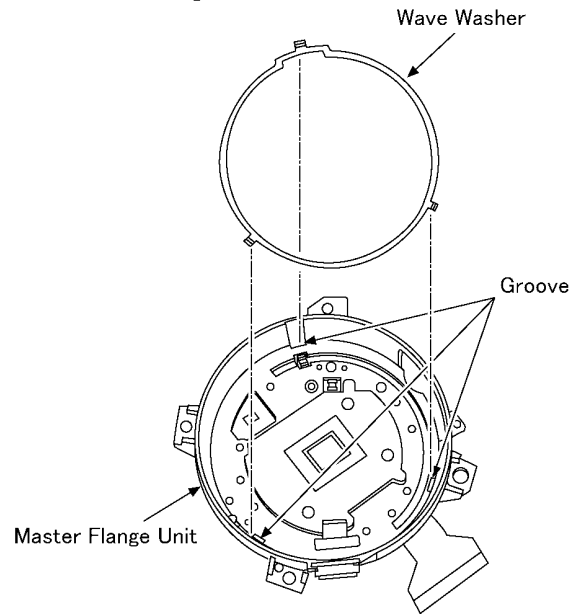

2. Pass the flex through the hole of master flange unit.
3. Align the screw hole, hold the master flange unit evenly and screw down it.

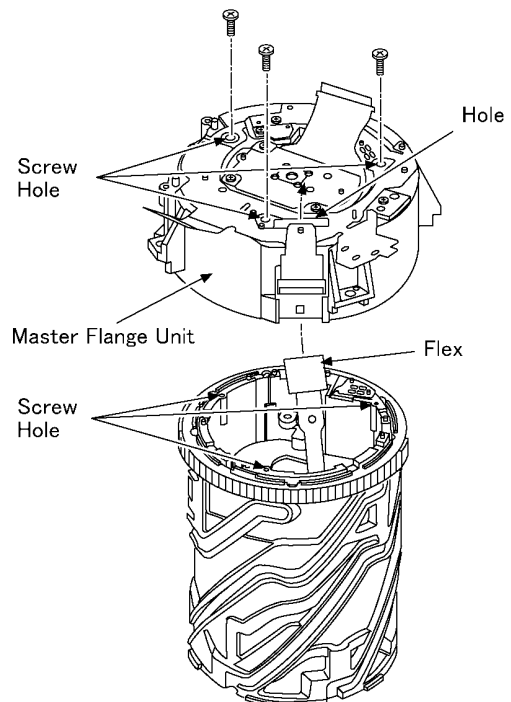

### 8.4.4. Removal of the Cam Frame Unit

1. Remove the cam frame unit in the direction of arrow.

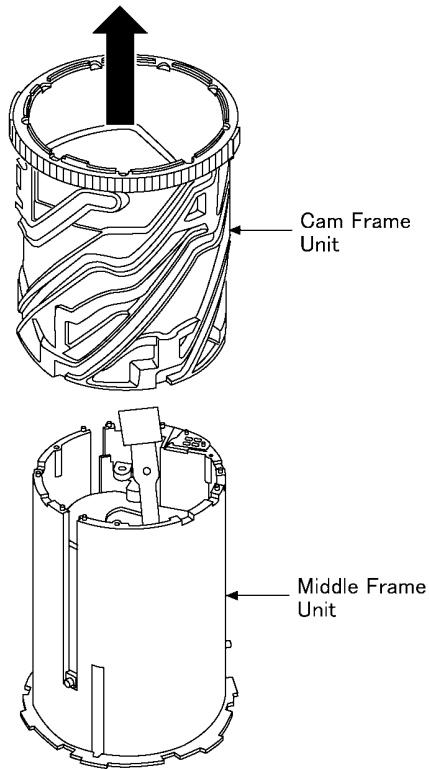

#### NOTE: (When Installing)

- Align the  $\Delta$  mark of cam frame unit and the  $\Delta$  mark of middle frame unit, and then install them.

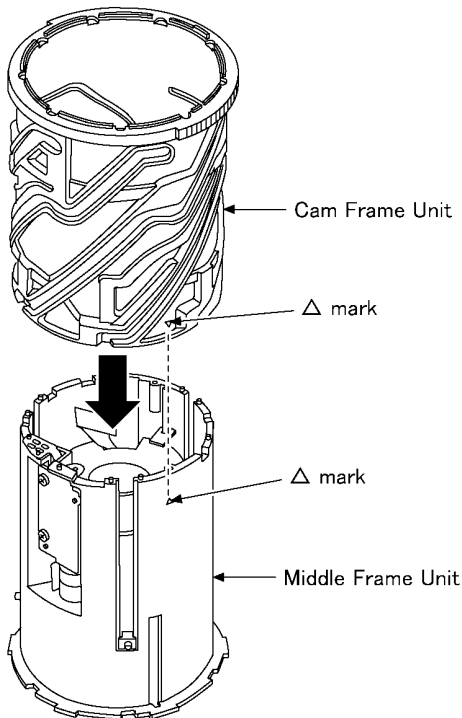

### 8.4.5. Removal of the Focus Motor Unit

- Detach the flex from 2 ribs of middle frame unit.
- Unscrew the 2 screws (D).

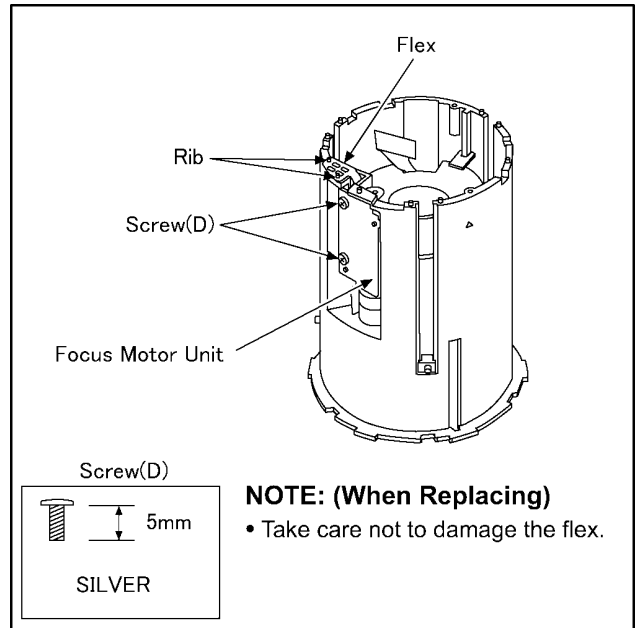

#### NOTE: (When Installing)

- Blow air to the screw shaft of focus motor unit to prevent the adhesion of foreign material.
- Apply grease to the screw shaft of focus motor unit.
- Align the screw shaft to the rack of 4th lens frame unit for insertion.  
(Set the 4th lens frame unit at the master flange side)

- Grease Application Area

Grease: V-6S

Amount of application:  $4.5 \pm 0.3\text{mg}$

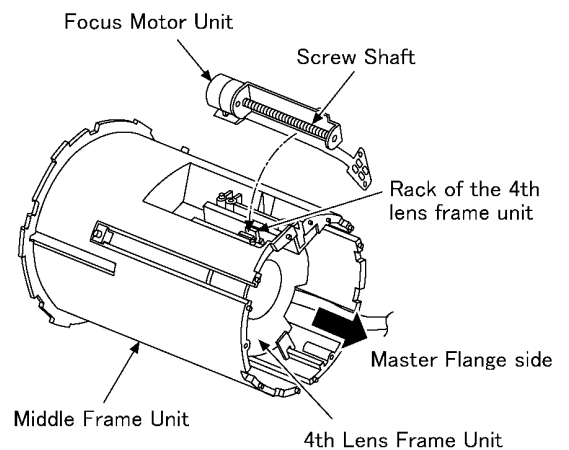
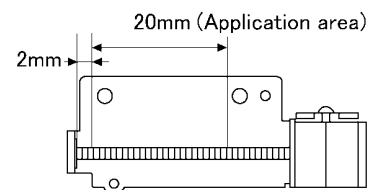

## 8.4.6. Removal of the 3rd Lens Frame Unit and 4th Lens Frame Unit

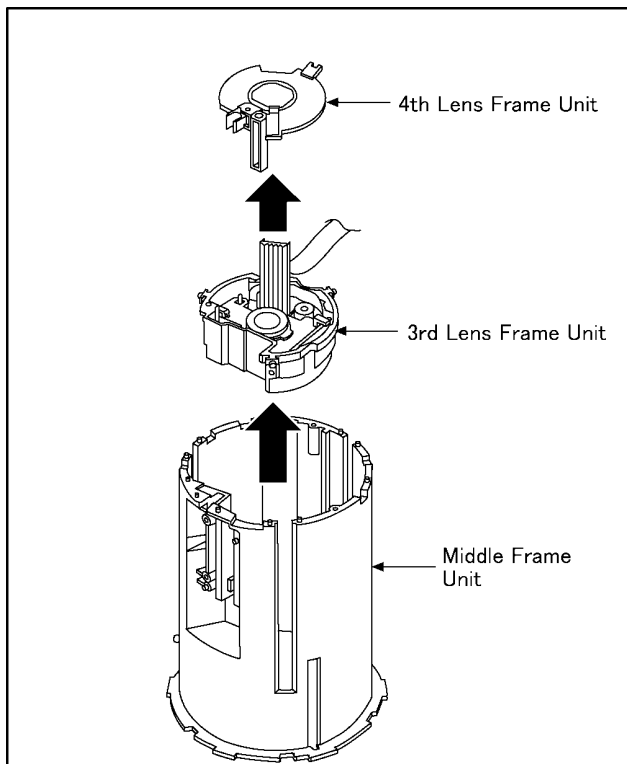

### NOTE: (When Replacing)

- Take care not to damage the flex.
- When lift the 3rd lens frame unit and the 4th lens frame unit, take care not to put fingerprint of the lens.

### NOTE: (When Installing)

1. Align the projection part of 3rd lens frame unit and the groove part of middle frame unit, and then install them.

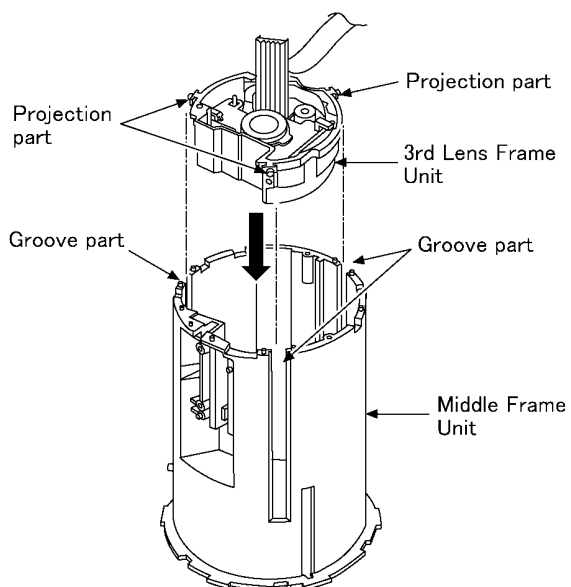

### NOTE: (When Installing)

2. Align the 4th lens frame unit and both the shaft and convex part of middle frame unit, and the install them.

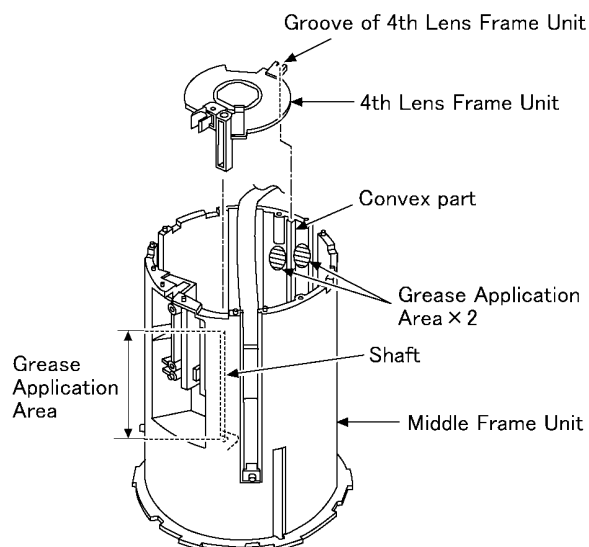

### • Grease Application Area

- Convex part of middle frame unit × 2  
Grease: V-6S  
Amount of application:  $1.5 \pm 0.15\text{mg}$
- Shaft  
Grease: V-6S  
Amount of application:  $3 \pm 0.3\text{mg}$

## 8.5. Removal of the CCD Unit

To prevent the CCD unit from catching the dust and dirt, do not remove the CCD unit except for replacing.

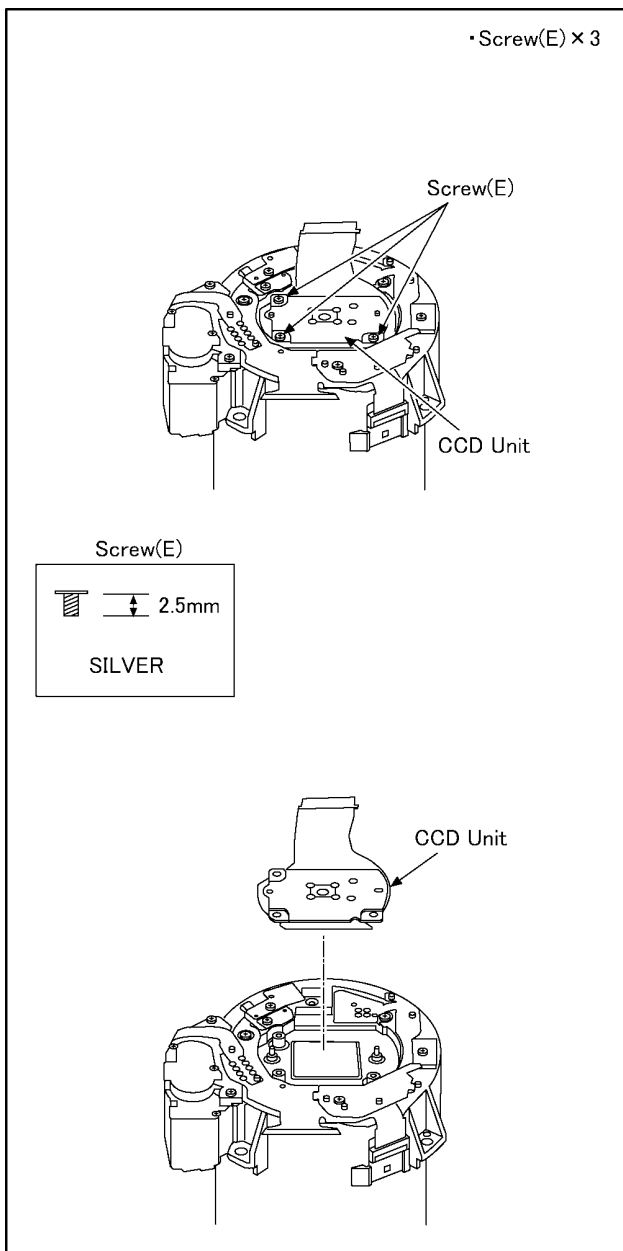

# 9 Measurements and Adjustments

## 9.1. Introduction

When servicing this unit, make sure to perform the adjustments necessary based on the part(s) replaced. Before disassembling the unit, it is recommended to back up the camera data stored in flash-rom as a data file.

### **IMPORTANT NOTICE (After replacing the MAIN P.C.B.)**

After replacing the MAIN P.C.B., it is necessary to use the "DIAS" software to allow the release of adjustment flag(s).

The Adjustment software "DIAS" is available at "TSN Website". To download, click on "Support Information from NWBG/VDBG-AVC".

\*DIAS (DSC Integrated Assist Software)

### **NOTE: (When replacing the Lens unit, Master flange unit and CCD unit)**

- When the CCD unit is unavoidably removed for Lens unit, Master flange unit and CCD unit replaced, an optical adjustment is necessary after parts are exchanged.
- The adjustment software (DSC\_Tilt) is necessary to execute an optical adjustment.
- Please inquire the adjustment software of the service base or the CS promotion center.

## 9.2. Before Disassembling the unit

### 9.2.1. Initial Setting Release

The cameras specification are initially set in accordance with model suffix (such as EB, EG, GK, GC, and so on.).

Unless the initial setting is not released, an automatic alignment software in the camera is not able to be executed when the alignment is carried out.

#### **Note:**

The initial setting should be again done after completing the alignment. Otherwise, the camera may not work properly.

Therefore as a warning, the camera display a warning symbol "!" on the LCD monitor every time the camera is turned off.

Refer to the procedure described in "3.5.2 INITIAL SETTINGS" for details.

#### **[ How to Release the camera initial setting ]**

##### **Preparation:**

1. Attach the Battery or AC Adaptor with a DC coupler to the unit.  
(Since this unit has built-in memory, it can be performed without inserting SD memory card.)

##### **Step 1. Temporary cancellation of "INITIAL SETTINGS":**

Set the mode dial to "[ P ] (Program AE mode)".

While keep pressing "[ UP ] of Cursor button" and [ MOTION PICTURE ] button simultaneously, turn the Power on.

##### **Step 2. Cancellation of "INITIAL SETTINGS":**

Press the [ PLAYBACK ] button, then playback the picture.

Press "[ UP ] of Cursor button" and [ MOTION PICTURE ] button simultaneously. (The camera will beep after this.)

Turn the Power off. (The warning symbol "!" is displayed on the LCD monitor.)

### 9.2.2. Flash-Rom Data Backup

When trouble occurs, it is recommended to backup the Flash-rom data before disassembling the unit.

There are two kinds of Flash-rom data backup methods:

**[ ROM\_BACKUP (Method of Non-PC backup) ]**

1. Insert the SD-card into the camera.
2. Set the camera to "Temporary cancellation of the initial settings".
3. Select the "SETUP" menu.  
From the "SETUP" menu, select "ROM BACKUP".

**NOTE:**

This item is not listed on the customer's "SETUP" menu.

4. When this "ROM\_BACKUP" item is selected, the following submenus are displayed.



Fig.2-1



Fig.2-2

Item	Function	Details
DSC → SD	Save all the DSC's Flash-rom data to SD-CARD	*DSC's Flash-rom data is saved to the SD-CARD as a data file by the same format as the TATSUJIN software for the previous models. (DATA BACKUP) -File location: ROOT DIRECTORY in SD-CARD. -File Name: 1) User Setup Information data: <Model Number>U.txt [Example: DMC-FX66 : "FX66U.txt"] 2) Optical Adjustment data: <Model Number>F.txt [Example: DMC-FX66 : "FX66F.txt"] *If the concerned file already exists, "OVERWRITE?" message is displayed.
SDALL → DSC (ID CHECK)	Write the all data to DSC's Flash-rom from SD-CARD	*The backup data being stored in the SD card is transferred to DSC unit. *ID CHECK: When the model ID is different, data is not transferred.
SDALL → DSC (FORCE)	Write the all data to DSC's Flash-rom from SD-CARD	*FORCE: Even if the model ID is different, data is transferred. ※If the main PCB is replaced, select "SDALL → DSC (FORCE)".
SDUSER → DSC (FORCE)	Only "User setup information" is written from the saved file in the SD-CARD to DSC's Flash-rom.	*Only the user's "setup" setting condition is transferred to DSC unit. *FORCE: Even if the model ID is different, the data is transferred.
! → LUMIX	Shipping set without initializing "User setup information"	*Initial setting is executed without initializing the user's set up setting condition. ※ The initial setting must perform while the Self-timer LED is blinking. ※ The picture data stored in the built-in memory of the DSC is not erased, with this operation.

**[ DSC Integrated Assist Software (Method of Using PC) ]**

Same as TATSUJIN software for previous models.

### 9.2.3. Light Box

If using VFK1164TDVLB Light Box, remove the lens connection ring by loosening three hexagon screws.

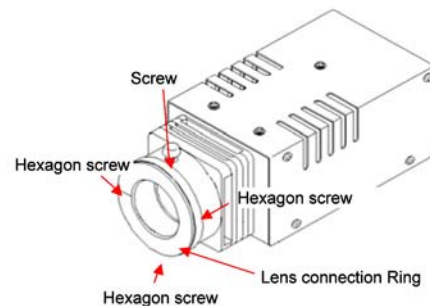

## 9.3. Details of Electrical Adjustment

### 9.3.1. How to execute the Electrical Adjustment

It is not necessary to connect the camera to a PC to perform adjustments.

“Flag reset operation” and “Initial setting operation” are required when carrying out the alignment, follow the procedure below.

#### 9.3.1.1. Startup Electrical Adjustment mode

1. Release the initial settings.
2. Insert a recordable SD card.  
(Without a SD card, the automatic adjustment can not executed.)
3. Procedure to set the camera into adjustment mode:
  - a. Set the mode dial to “[ P ] (Program AE mode)”.
  - b. Turn the Power off.
  - c. Turn the Power on pressing [ MENU/SET ] and [ MOTION PICTURE ] simultaneously.  
LCD monitor displays “SERVICE MODE”.(Refer to Fig. 3-1)



Fig. 3-1

#### 9.3.1.2. Status Adjustment Flag Setting

Reset (Not yet adjusted) the status flag condition.

1. After pressing the [ DISPLAY ] button, the LCD monitor displays the Flag status screen (Refer to Fig.3-2)
2. Select item by pressing the Cursor buttons. (Gray cursor is moved accordingly.)
3. Press the [ Delete ] button.

**NOTE:**

The selected item's flag has been changed from “F (green)” to “0 (yellow)”.

\*Flag conditions:

F (green)

means that the alignment has been completed and the status flag condition is set. In this case, the flag condition should be reset, if you try to carry out the automatic alignment.

0 (yellow)

means that the alignment has been not “completed” and the status flag condition is “reset”. In this case, automatic alignment is available.

- In case of setting the status flag into set condition again without completion of the alignment, the status flag should be SET by using PC, or UNDO by using ROM BACKUP function.



Fig. 3-2



### 9.3.1.3. Execute Adjustment (In case of “OIS Adjustment”)

1. Perform step “9.3.1.1.” to “9.3.1.2.”, to reset the OIS flag status “F” (Set) to “0” (Reset)
2. Press [ DISPLAY ] button after Flag reset.  
OIS Adjustment screen is displayed on the LCD panel.  
(Refer to Fig.3-3)
3. Press the [ Shutter ] button. The adjustment will start automatically.



Fig.3-3

4. When the adjustment is completed successfully, adjustment report menu appears with Green OK on the LCD monitor. (Refer to Fig.3-4)

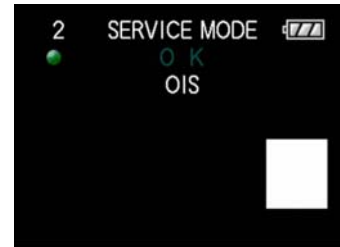

Fig.3-4

### 9.3.1.4. Attention point during Adjustment

1. Step “9.3.1.3.” procedure shows OIS adjustment as an example. To perform the adjustment, refer to the “9.3.2. Adjustment Specifications” table which shows key point for each adjustment.
2. Do not move the light box, the camera or the chart while adjusting. If one of these is moved accidentally, start the adjustment again.
3. Do not press any buttons/keys until the default menu (Fig.3-5) is displayed on the LCD monitor. Otherwise, adjustment data may not be stored properly.
4. If the adjustment is interrupted accidentally, the alignment data may not be properly saved in the Flash-rom.

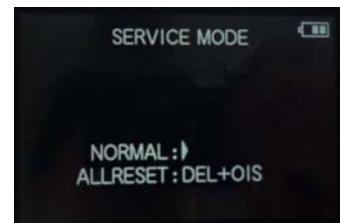

Fig.3-5

### 9.3.1.5. Finalizing the Adjustment

1. Several adjustment flags can be reset (“F” into “0”) at the same time. In this case, when the adjustment has been completed, the screen will change showing the adjustment for the next item until all reset items are completed.  
Also, when the shutter button is pressed, the screen jump to the next adjustment item.
2. To cancel the adjustment mode while in the process of performing the adjustment, follow this procedures.
  - (1) Press [ Delete ] button.
  - (2) Press [ RIGHT ] of Cursor button.

#### NOTE:

- If adjustment is cancelled with above procedure, adjustment is not completed. Make sure to adjust it later.
- Adjustment software “DIAS” is able to control the status of the adjustment flags.



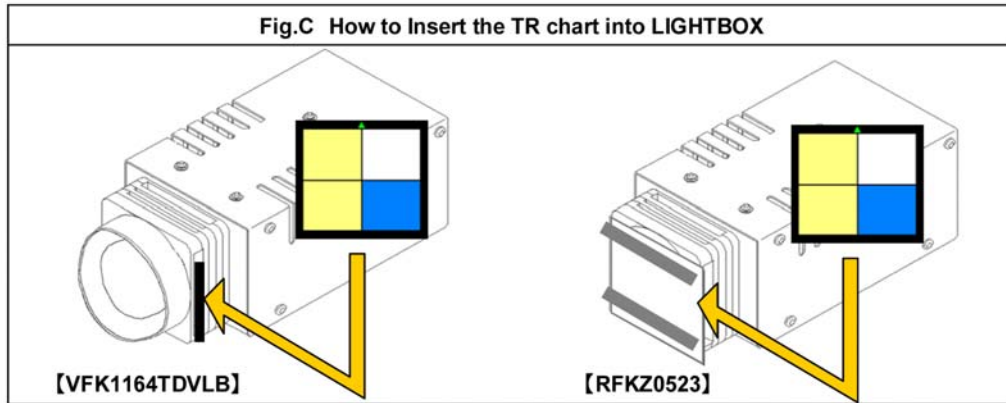
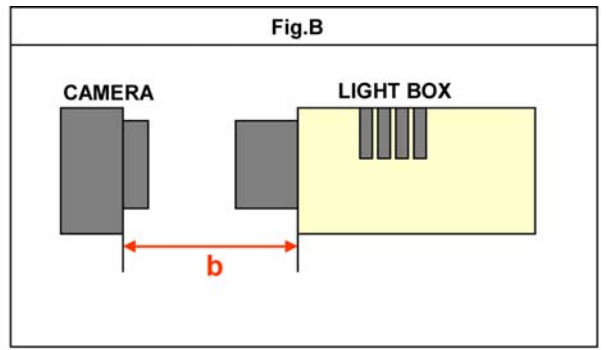
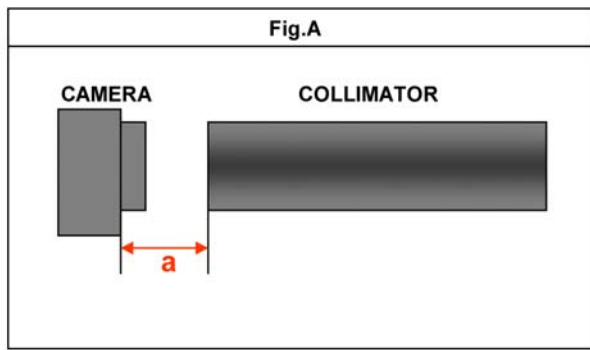

■ **IMPORTANT NOTICE** (After replacing the MAIN P.C.B.)  
 After replacing the MAIN P.C.B., make sure to perform the "INITIAL SETTINGS" first, then release the "INITIAL SETTINGS" in order to proceed the electrical adjustment.

NOTE:

- 1). If electrical adjustment or data re-writing is executed before "INITIAL SETTINGS", suffix code list is never displayed, and it cannot be chosen suitable suffix code.
- 2). Never remove the battery during initial setting in process.

## 9.4. After Adjustment

### 9.4.1. Initial Setting

Since the initial setting has been released to execute the built-in adjustment software, it should be set up again before shipping the camera to the customer.

Refer to the procedure described in "3.4.2. INITIAL SETTINGS" for details.

#### [ IMPORTANT ]

1. The initial setting should be done again after completing the alignment. Otherwise, the camera will not work properly. Therefore as a warning, the camera display a warning symbol "!" on the LCD monitor every time the camera is turned off.
2. Confirm that status of all adjustment flag show "F". Even if one of the adjustment flag shows "0", initial setting programmed is never executed.
3. Adjustment software "DIAS" is able to control the status of the adjustment flags.  
 The Adjustment software "DIAS" is available at "TSN Website", therefore, access to "TSN Website" at "Support Information from NWBG/VDBG-AVC".

# 10 Maintenance

## 10.1. Cleaning Lens, Viewfinder and LCD Panel

Do not touch the surface of lens, Viewfinder and LCD Panel with your hand.

When cleaning the lens, use air-Blower to blow off the dust.

When cleaning the LCD Panel, dampen the lens cleaning paper with lens cleaner, and the gently wipe the its surface.

**Note:**

The Lens Cleaning KIT ; VFK1900BK (Only supplied as 10 set/Box) is available as Service Aid.

# Service Manual

---

## Diagrams and Replacement Parts List

### Digital Camera

Model No.

DMC-FZ40P	DMC-FZ45EB
DMC-FZ40PC	DMC-FZ45EE
DMC-FZ40PR	DMC-FZ45EF
DMC-FZ40PU	DMC-FZ45EG
DMC-FZ40GC	DMC-FZ45EP
DMC-FZ40GK	
DMC-FZ40GN	
DMC-FZ40GT	

Vol. 1  
 Colour  
 (K).....Black Type

### Table of contents

S1. About Indication of The Schematic Diagram.....	S-1
S1.1. Important Safety Notice.....	S-1
S2. Voltage Chart .....	S-2
S2.1. Flash P.C.B. ....	S-2
S3. Block Diagram.....	S-3
S3.1. Overall Block Diagram .....	S-3
S4. Schematic Diagram.....	S-4
S4.1. Interconnection Diagram .....	S-4
S4.2. Flash Schematic Diagram .....	S-5
S4.3. CCD Flex Schematic Diagram .....	S-6
S4.4. Lens Flex Schematic Diagram .....	S-7
S5. Print Circuit Board .....	S-8
S5.1. Flash P.C.B. ....	S-8
S5.2. CCD Flex P.C.B.....	S-9
S5.3. Lens Flex P.C.B.....	S-10

S6. Replacement Parts List.....	S-11
S7. Exploded View .....	S-15
S7.1. Frame and Casing Section.....	S-15
S7.2. Camera Lens Section.....	S-16
S7.3. Packing Parts and Accessories Section (1) .....	S-17
S7.4. Packing Parts and Accessories Section (2) .....	S-18

## S1. About Indication of The Schematic Diagram

### S1.1. Important Safety Notice

COMPONENTS IDENTIFIED WITH THE MARK  $\triangle$  HAVE THE SPECIAL CHARACTERISTICS FOR SAFETY. WHEN REPLACING ANY OF THESE COMPONENTS USE ONLY THE SAME TYPE.

1. Although reference number of the parts is indicated on the P.C.B. drawing and/or schematic diagrams, it is NOT mounted on the P.C.B. when it is displayed with "\$" mark.
2. It is only the "Test Round" and no terminal (Pin) is available on the P.C.B. when the TP (Test Point) indicated as "●" mark.
3. The voltage being indicated on the schematic diagram is measured in "Standard-Playback" mode when there is no specify mode is mentioned.
4. Although the voltage and waveform available on here is measured with standard frame, it may be differ from actual measurement due to modification of circuit and so on.
5. The voltage being indicated here may be include observational-error (deviation) due to internal-resistance and/or reactance of equipment. Therefore, handle the value indicated on here as reference.
6. Use the parts number indicated on the Replacement Parts List .
7. Indication on Schematic diagrams:

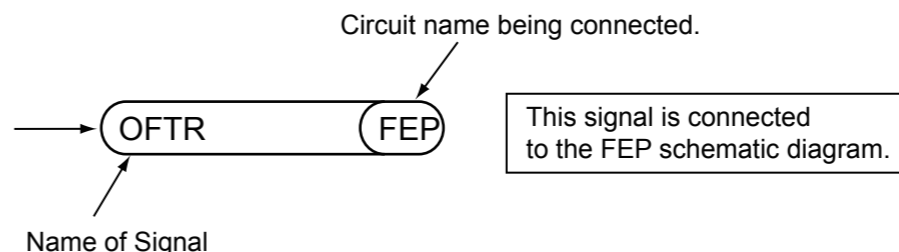

## S2. Voltage Chart

Note) Indicated voltage values are the standard values for the unit measured by the DC electronic circuit tester (high-impedance) with the chassis taken as standard.  
Therefore, there may exist some errors in the voltage values, depending on the internal impedance of the DC circuit tester.

### S2.1. Flash P.C.B.

REF No.	PIN No.	POWER ON
Q8004	1	8.1
Q8004	2	8.1
Q8004	3	0
Q8004	4	0
Q8004	5	8.1
Q8004	6	8.1
QR8001	1	0
QR8001	2	4.8
QR8001	3	0
QR8001	4	5.0
QR8001	5	4.8
QR8001	6	0
QR8002	E	0
QR8002	C	4.8
QR8002	B	0

# S3. Block Diagram

## S3.1. Overall Block Diagram

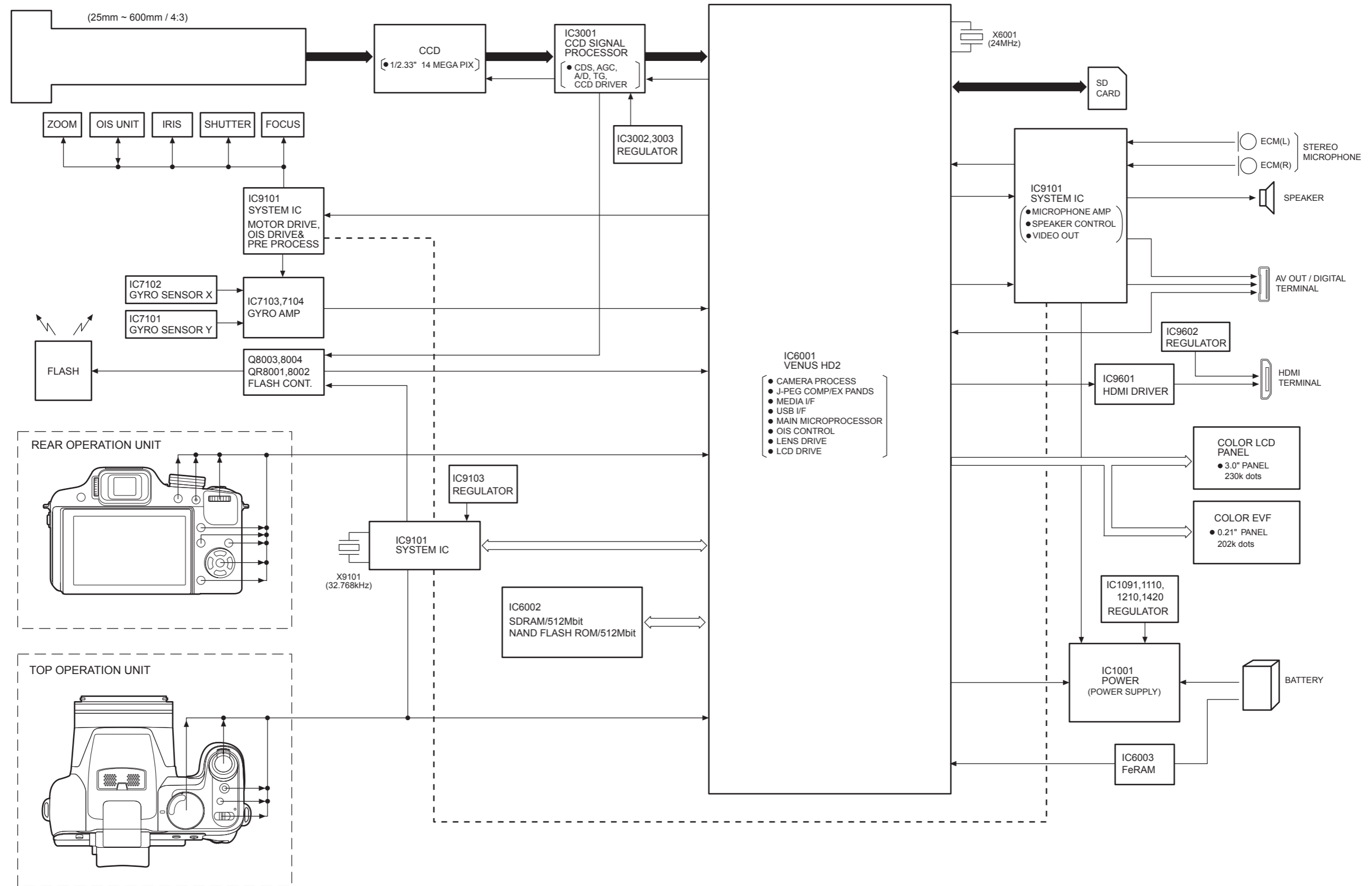

# S4. Schematic Diagram

## S4.1. Interconnection Diagram

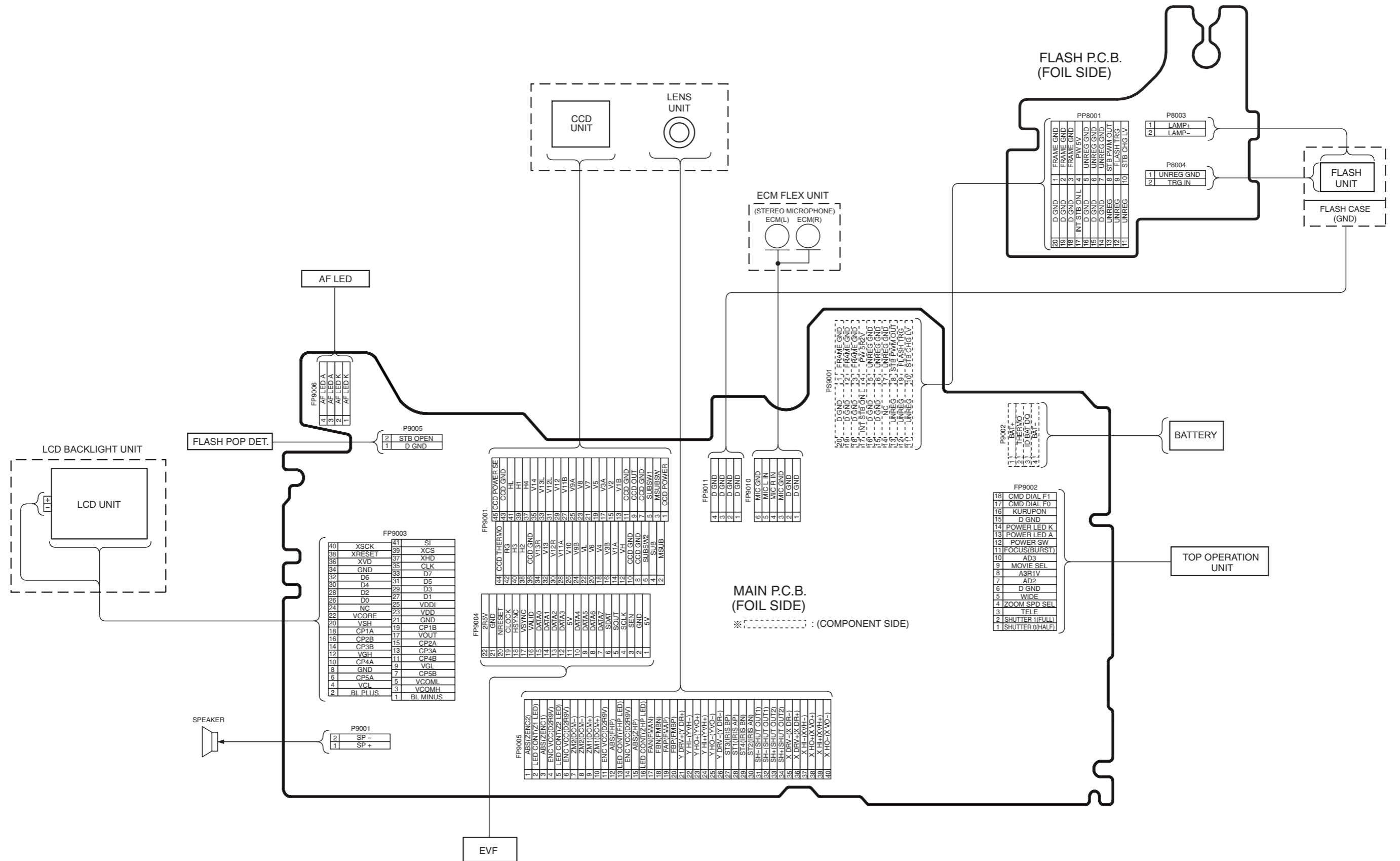



# S4.2. Flash Schematic Diagram

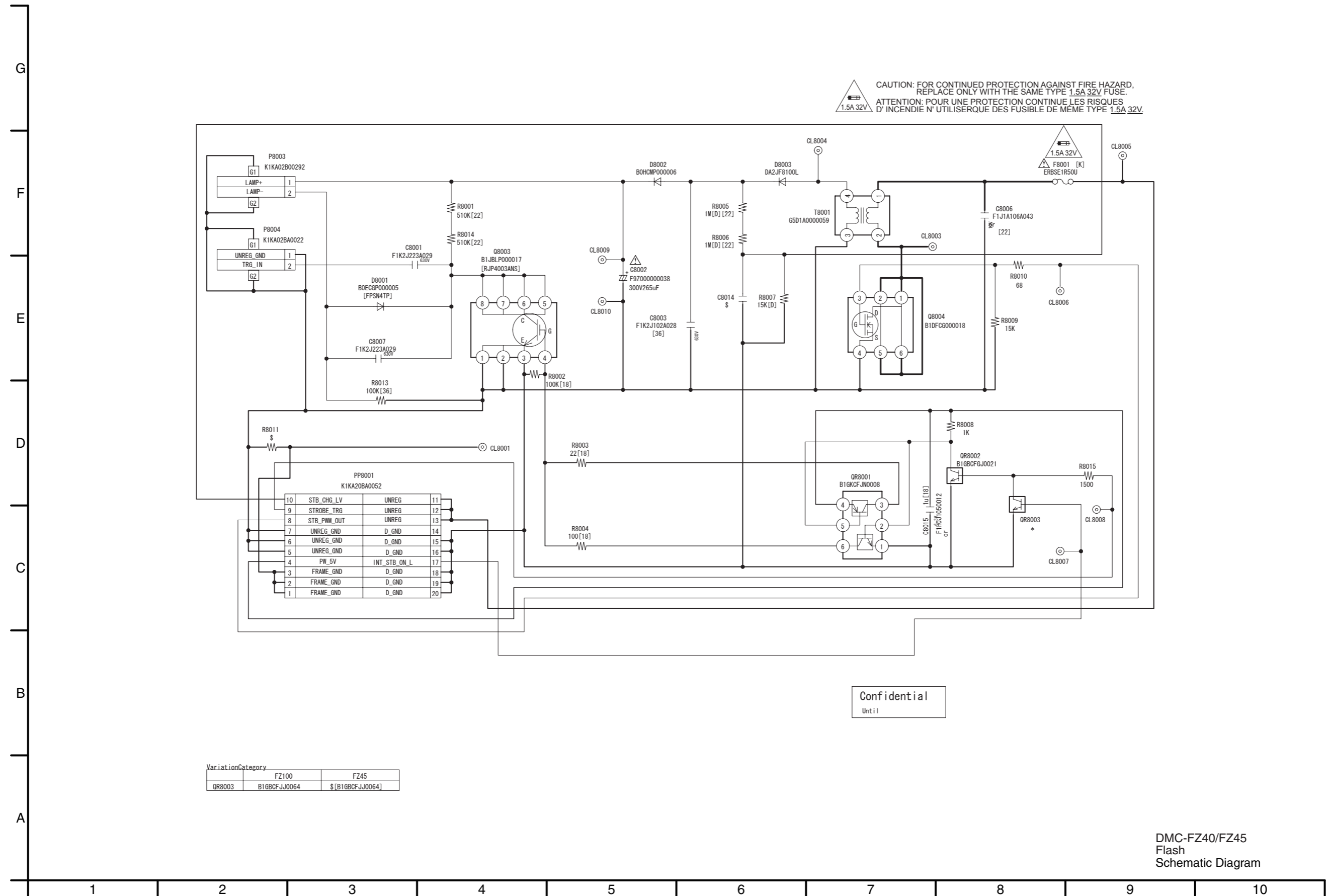

Confidential  
Until

VariationCategory	FZ100	FZ45
QR8003	B1GBCFJJ0064	\$(B1GBCFJJ0064)

### S4.3. CCD Flex Schematic Diagram

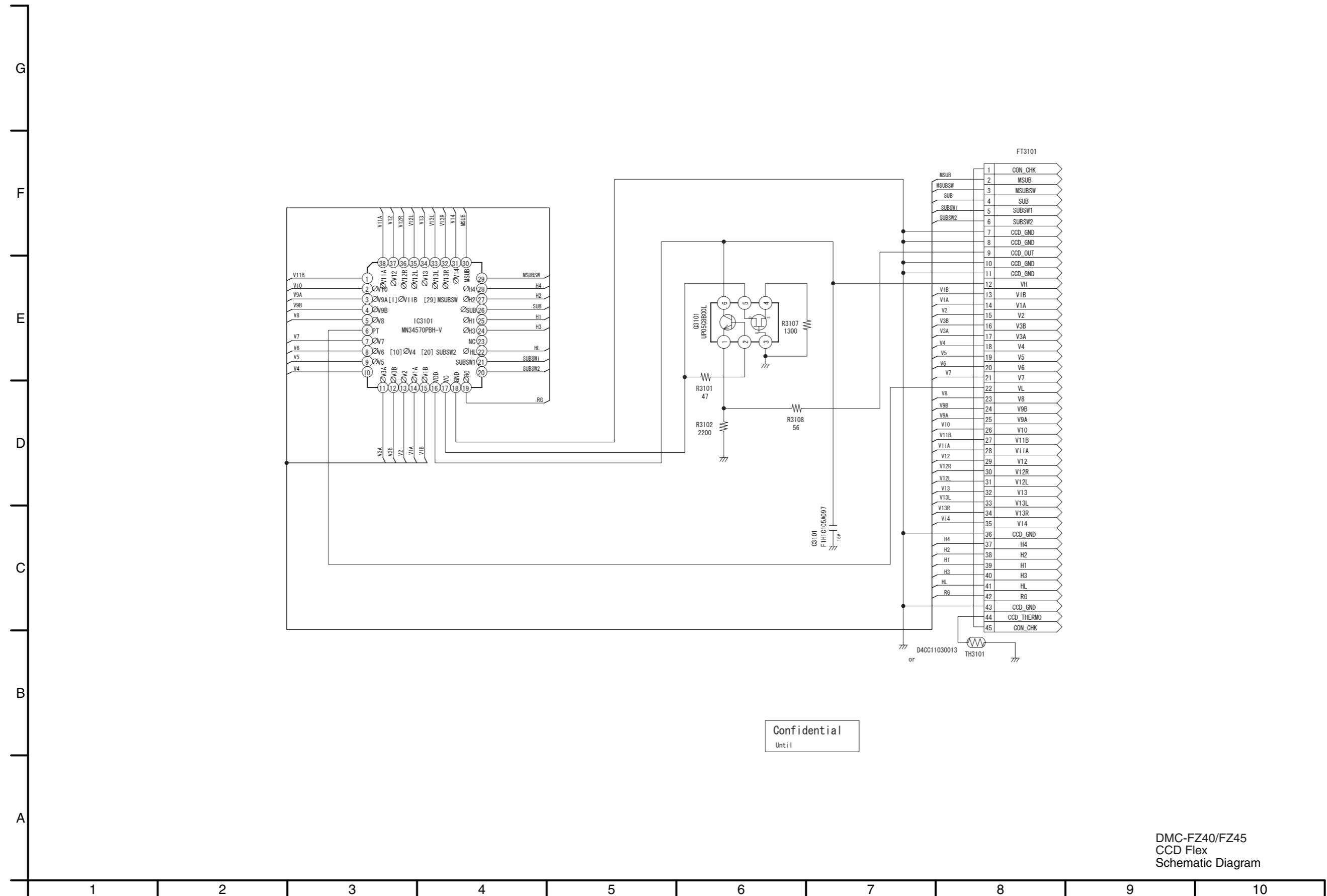

Confidential  
Until

# S4.4. Lens Flex Schematic Diagram

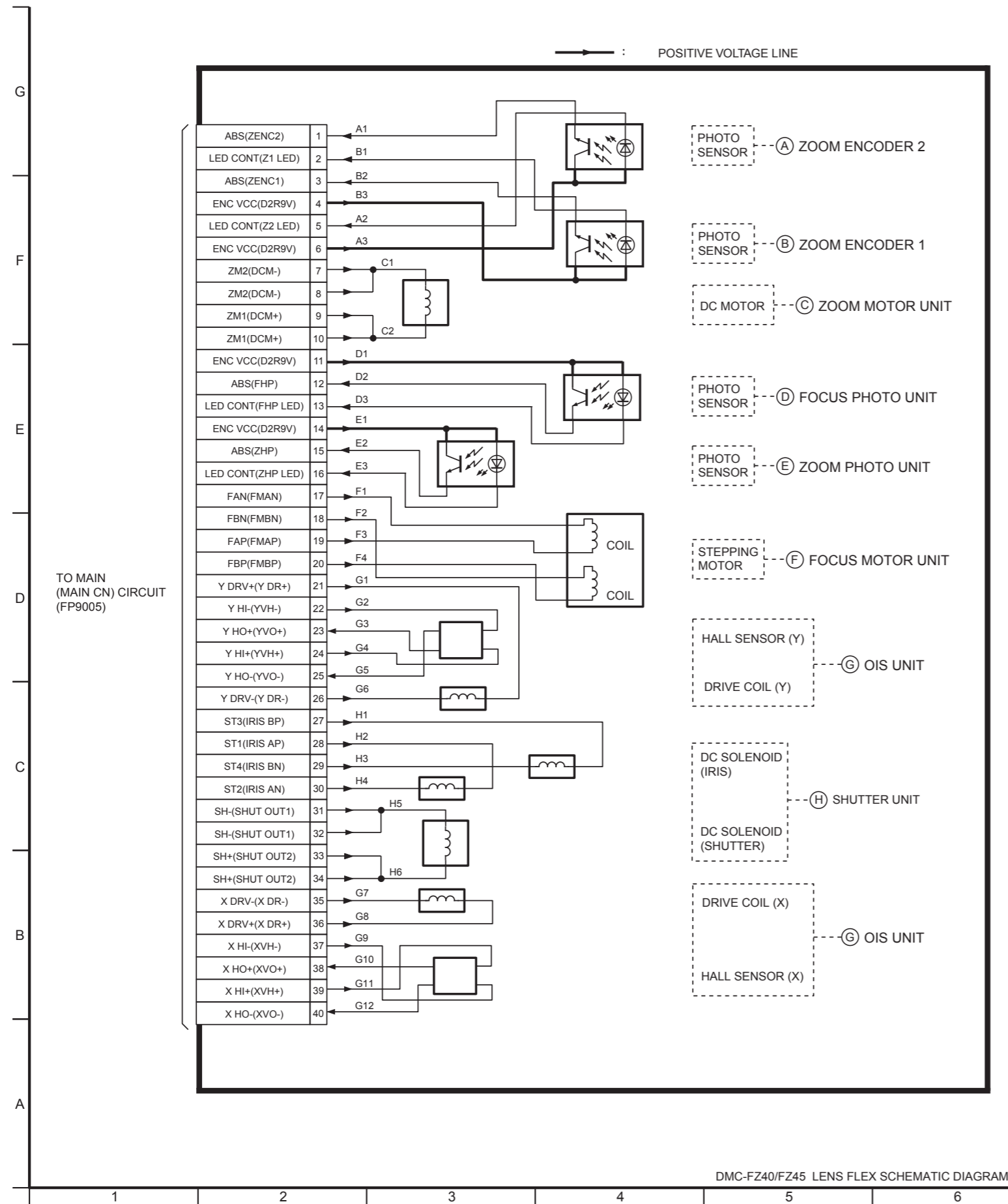

# S5. Print Circuit Board

## S5.1. Flash P.C.B.

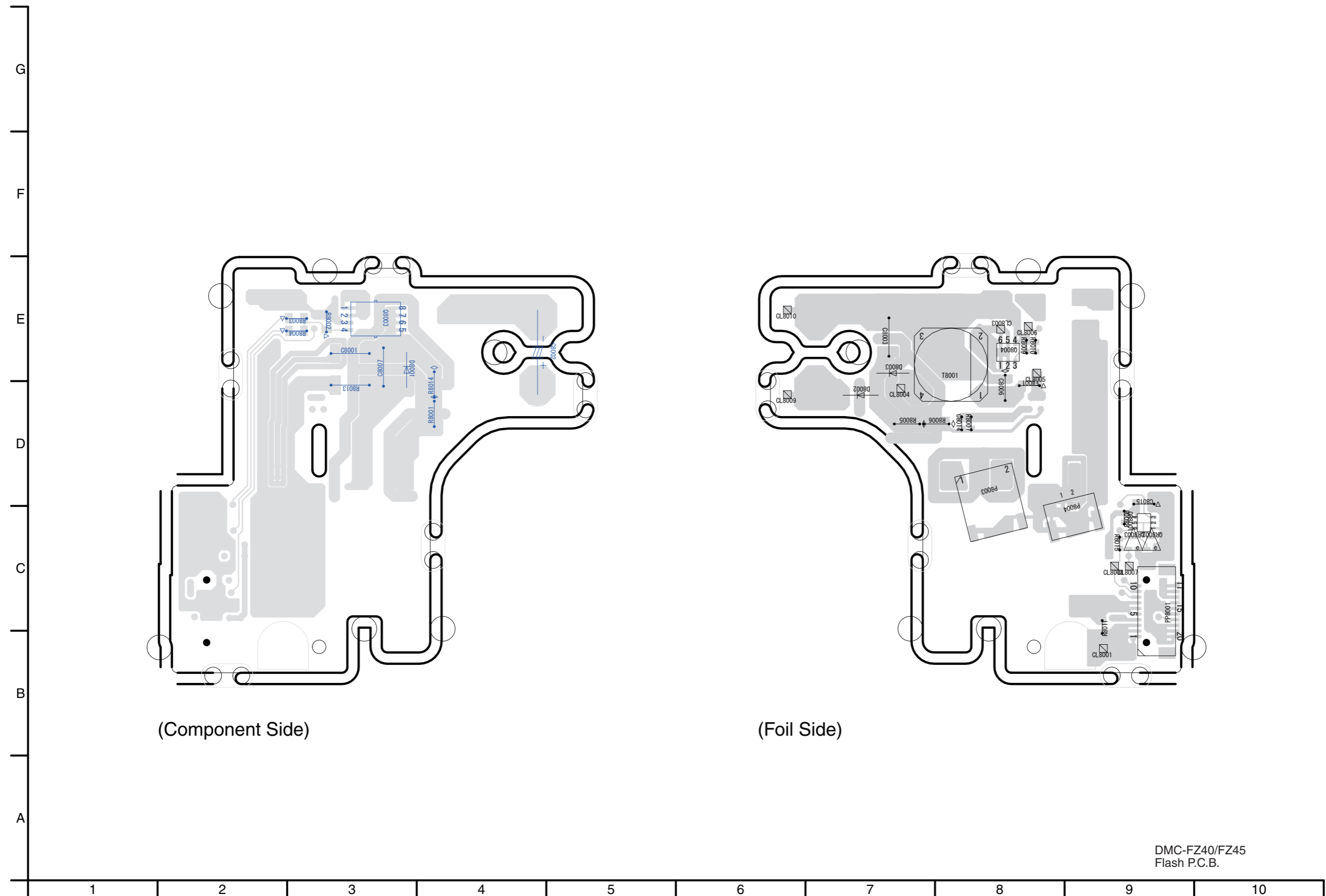

S5.2. CCD Flex P.C.B.

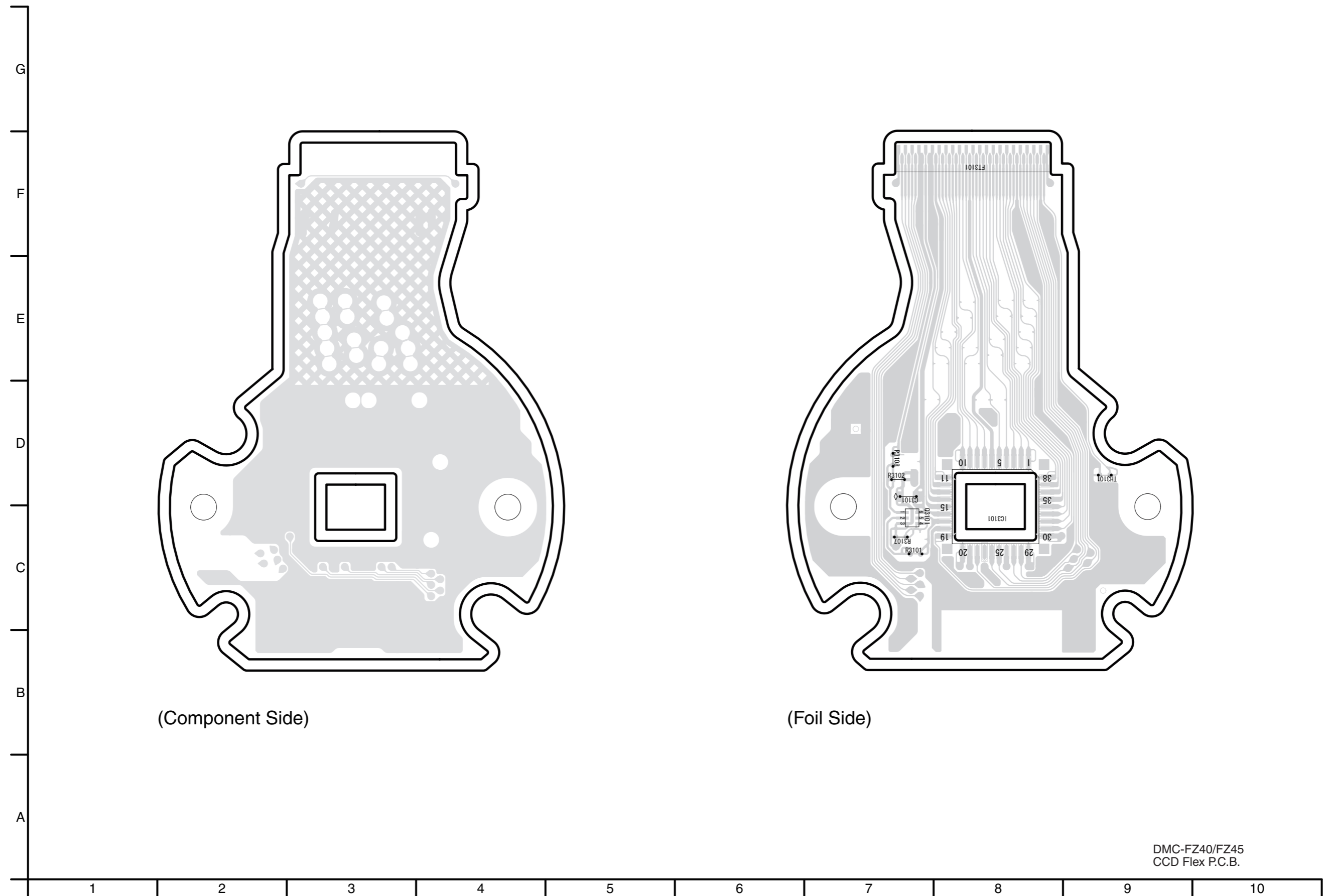

DMC-FZ40/FZ45  
CCD Flex P.C.B.

S5.3. Lens Flex P.C.B.

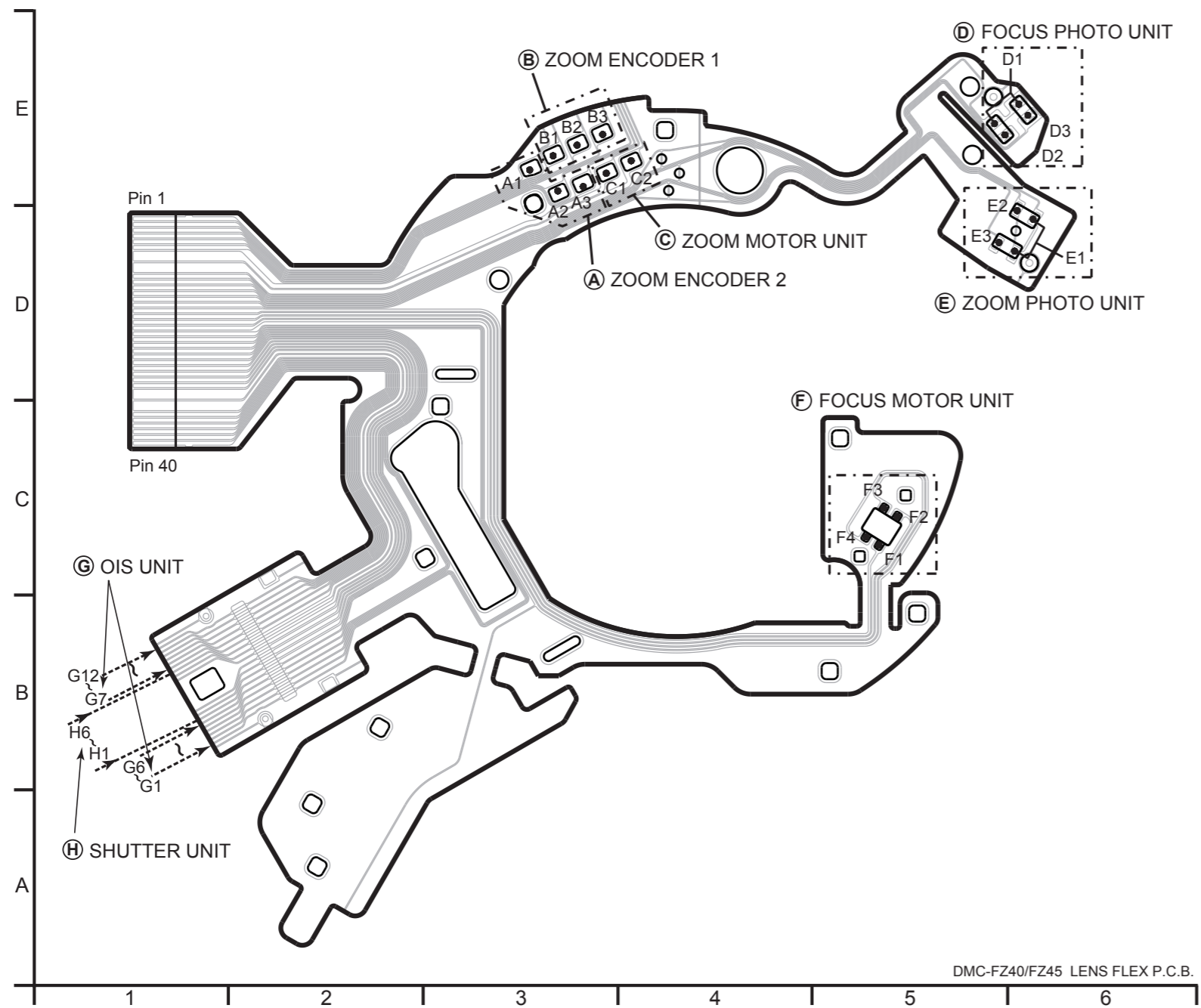

## S6. Replacement Parts List

- Note:
1. \* Be sure to make your orders of replacement parts according to this list.
  2. **IMPORTANT SAFETY NOTICE**  
Components identified with the mark  have the special characteristics for safety.  
When replacing any of these components, use only the same type.
  3. Unless otherwise specified,  
All resistors are in OHMS, K=1,000 OHMS. All capacitors are in MICRO-FARADS (uf), P=uuF.
  4. The marking (RTL) indicates the retention time is limited for this item. After the discontinuation of this assembly in production, it will no longer be available.
  5. Supply of CD-ROM, in accordance with license protection, is allowable as replacement parts only for customers who accidentally damaged or lost their own.

**E.S.D. standards for Electrostatically Sensitive Devices, refer to PREVENTION OF ELECTROSTATIC DISCHARGE (ESD) TO ELECTROSTATICALLY SENSITIVE (ES) DEVICES section.**

**Definition of Parts supplier:**

1. Parts marked with [ENERGY] in the remarks column are supplied from Panasonic Corporation Energy Company.
2. Parts marked with [PAVCSG] in the remarks column are supplied from PAVCSG. Others are supplied from AVC-CSC-SPC.





DMC-FZ40P-K

Ref.No.	Part No.	Part Name & Description	Pcs	Remarks	Ref.No.	Part No.	Part Name & Description	Pcs	Remarks
1	VDW2044	LENS RING FRONT	1	[PAVCSG]	B62	XQN16+BJ4FN	SCREW	1	
2	VGQ0A13	AF LIGHT CASE	1	[PAVCSG]	B63	XQN16+BJ4FN	SCREW	1	
3	VYK4G62	FRONT CASE UNIT	1	[DMC-FZ40] [PAVCSG]	B64	XQN16+BJ4FN	SCREW	1	
3	VYK4G51	FRONT CASE UNIT	1	[DMC-FZ45] [PAVCSG]	B65	XQN16+BJ5FN	SCREW	1	
3-1	VGQ0M31	GRIP PIECE FRONT	1	[PAVCSG]	B66	XQN16+BJ5FN	SCREW	1	
4	EFN-AMBM7ZD	FLASH UNIT	1	[PAVCSG]	B67	XQN16+BJ4FN	SCREW	1	
5	VEP54020A	ECM FLEX UNIT	1	[PAVCSG]	B68	XQN16+BJ4FJK	SCREW	1	
6	VMB4377	FLASH POP UP SPRING	1	[PAVCSG]	B69	XQN16+BJ4FJK	SCREW	1	
7	VMP9666	FLASH EARTH PLATE	1	[PAVCSG]	B70	VHD2062	SCREW	1	
8	VMS7911	FLASH SHAFT	1	[PAVCSG]	B71	VHD2062	SCREW	1	
9	VMT1962	MIC DAMPER	1	[PAVCSG]					
10	VMT2011-A	MIC CUSHION	1	[PAVCSG]					
11	VYK4B81	FLASH CASE TOP UNIT	1	[PAVCSG]	100	VXW1167	LENS UNIT (W/O CCD)	1	
12	VYK4B89	FLASH BASE UNIT	1	[PAVCSG]	101	VXP3444	1ST LENS FRAME UNIT	1	
13	VYQ3749	FLASH SW UNIT	1	[PAVCSG]	102	VXP3336	2ND LENS FRAME UNIT	1	
14	VWJ2223	GND FPC	1	[PAVCSG]	103	VXQ1969	MIDDLE FRAME UNIT	1	
15	VKM8616	FLASH CASE BOTTOM	1	[PAVCSG]	104	L6HA68ND0001	FOCUS MOTOR UNIT	1	
16	VYK4K91	REAR CASE UNIT	1	[DMC-FZ40]	105	VXP3337	3RD LENS FRAME UNIT	1	
16	VYK4K90	REAR CASE UNIT	1	[DMC-FZ45]	106	VXP3343	4TH LENS FRAME UNIT	1	
16-1	VMS7523	STRAP HOLDER	1	[PAVCSG]	107	VDW1953	CAM FRAME UNIT	1	
16-2	VGU0G09	CURSOR BUTTON	1	[PAVCSG]	108	VMC2134	WAVE WASHER	1	
16-3	VGU0G64	PLAY BUTTON	1	[PAVCSG]	109	VDW2108	MASTER FLANGE	1	
16-4	VMC2123	REAR EARTH PLATE	1	[PAVCSG]	110	VML4007	CAM STOPPER	1	
50	VGQ0M27	JACK HOLDER	1		112	L6DAADHD0001	ZOOM MOTOR UNIT	1	
51	L5EDDXE00008	EVF UNIT	1		113	VEK0Q46	LENS FPC UNIT	1	
52	K0RB02500002	TOP OPERATION UNIT	1		113-1	B3NBA0000015	PHOTO COUPLER	1	
53	VEP56113A	MAIN P.C.B.	1	P,PC,PR,PU,GC,GK,GN,GT,EE (RTL) E.S.D.	113-2	B3NBA0000011	PHOTO SENSOR	1	
53	VEP56113B	MAIN P.C.B.	1	EB,EF,EG,EP (RTL) E.S.D.	113-3	K1MN18BA0209	CONNECTOR 18P	1	
△ 53-1	ML-614S/ZTK	BATTERY	1	[ENERGY] (B9101)	116	VEK0R02	CCD FLEX UNIT	1	
54	VMP9671	SIDE FRAME (R)	1		B101	XQN16+CJ5FN	SCREW	1	
55	VMS7523	STRAP HOLDER	1		B102	XQN16+CJ5FN	SCREW	1	
56	VKF4714	JACK COVER	1		B103	XQN14+CJ3FN	SCREW	1	
57	VEK0Q95	AF LED FPC UNIT	1		B105	XQN16+CJ5FN	SCREW	1	
58	VMC2130	BATTERY EARTH PLATE (TOP)	1		B106	XQN16+CJ5FN	SCREW	1	
59	VGQ0M36	CONDENSOR COVER	1		B107	XQN16+CJ5FN	SCREW	1	
60	VYK4B82	BATTERY CASE UNIT	1		B108	XQN16+CJ5FN	SCREW	1	
60-1	VGQ0M26	COUPLER COVER	1		B109	XQN16+CJ5FN	SCREW	1	
60-2	VGU0G10	BATTERY DOOR LOCK KNOB	1		B110	VHD2109	SCREW	1	
60-3	VGU0G12	BATTERY LOCK KNOB	1		B111	VHD2109	SCREW	1	
60-4	VKF4713	BATTERY DOOR	1		B112	XQN14+CJ3FN	SCREW	1	
60-5	VMB4199	BATTERY LOCK SPRING	1		B113	XQN14+CJ3FN	SCREW	1	
60-6	VMB4385	BATTERY SPRING	1		B114	XQN14+CJ3FN	SCREW	1	
60-7	VMB4406	BATTERY DOOR SPRING	1						
60-8	VMP9670	BATTERY DOOR PLATE	1						
60-9	VMS7525	BATTERY DOOR HINGE SHAFT	1						
60-10	VQL2G54	BATTERY DOOR LABEL	1						
61	VEP58119B	FLASH P.C.B.	1	(RTL) E.S.D.					
△ 61-1	F9Z000000038	E.CAPACITOR	1	(C8002)					
62	VYK4E67	LCD UNIT	1						
63	VMP9665	SPEAKER FIX PLATE	1						
64	L0AA01A00053	SPEAKER	1						
65	VMP9673	LCD HOLDER	1						
66	VGQ0P47	WIRE FIX TAPE	1						
B1	VHD2252-A	SCREW	1	[PAVCSG]					
B2	VHD2252-A	SCREW	1	[PAVCSG]					
B3	VHD2252-A	SCREW	1	[PAVCSG]					
B4	XQN16+BJ4FN	SCREW	1	[PAVCSG]					
B6	VHD1870	SCREW	1	[PAVCSG]					
B7	VHD1870	SCREW	1	[PAVCSG]					
B8	VHD2150	SCREW	1	[PAVCSG]					
B9	VHD2251-A	SCREW	1	[PAVCSG]					
B10	VHD1870	SCREW	1	[PAVCSG]					
B50	VHD2179	SCREW	1						
B51	VHD2179	SCREW	1						
B52	VHD2179	SCREW	1						
B53	VHD2179	SCREW	1						
B54	VHD1870	SCREW	1						
B55	VHD1870	SCREW	1						
B56	VHD1870	SCREW	1						
B57	VHD1870	SCREW	1						
B58	XTV2+8JFN	SCREW	1						
B59	XTV2+8JFN	SCREW	1						
B60	XTV2+8JFN	SCREW	1						
B61	XTV2+8JFN	SCREW	1						

DMC-FZ40P-K

Ref.No.	Part No.	Part Name & Description	Pcs	Remarks
△ 200	----	BATTERY	1	P,PC,PU
△ 201	DE-A83BA	BATTERY CHARGER	1	P,PC,PU
202	K1HA14AD0003	USB CABLE W/PLUG	1	P,PC,PU
203	K1HA14CD0004	AV CABLE W/PLUG	1	P,PC,PU
204	VFF0667-S	CD-ROM (SOFTWARE)	1	P,PC,PU See "Notes"
205	VYQ5607	LENS CAP UNIT	1	P,PC,PU
206	VYQ5606	LENS HOOD UNIT	1	P,PC,PU
207	VPF1166	CAMERA BAG	1	P,PC,PU
208	VPK4550	PACKING CASE	1	P,PC
208	VYQ5772	PACKING CASE UNIT	1	PU
209	VPN7080	PAD	1	P,PC,PU
△ 210	VFF0677	CD-ROM (INSTRUCTION BOOK)	1	P,PC,PU
△ 211	VQT2X16	INSTRUCTION BOOK (ENGLISH/SPANISH)	1	P
△ 211	VQT2X17	SIMPLIFIED O/I (ENGLISH/CANADIAN FRENCH)	1	PC
△ 211	VQT2X18	SIMPLIFIED O/I (SPANISH/PORTUGUESE)	1	PU
212	VQC7823	O/I SOFTWARE (ENGLISH/CANADIAN FRENCH)	1	P,PC
212	VQC7824	O/I SOFTWARE (SPANISH/PORTUGUESE)	1	PU
213	VPF1230	BAG, POLYETHYLENE	1	P,PC,PU
214	VFC4453	SHOULDER STRAP	1	P,PC,PU
217	VQL2C67	CANADIAN-FRENCH OPERATING	1	PC
△ 300	----	BATTERY	1	PR,GC,GN,GT,EB,EE,EF,EG, EP,GK
△ 301	DE-A84EA	BATTERY CHARGER	1	PR
△ 301	DE-A84BA	BATTERY CHARGER	1	GC,GK
△ 301	DE-A84AA	BATTERY CHARGER	1	GN,EB,EE,EF,EG,EP
△ 301	DE-A84CA	BATTERY CHARGER	1	GT
302	K1HA14AD0003	USB CABLE W/PLUG	1	EXCEPT P,PC,PU
303	K1HA14CD0004	AV CABLE W/PLUG	1	EXCEPT P,PC,PU
304	VFF0668-S	CD-ROM (SOFTWARE)	1	GK See "Notes"
304	VFF0667-S	CD-ROM (SOFTWARE)	1	PR,GC,GN,GT,EB,EE,EF, EG,EP See "Notes"
305	VYQ5607	LENS CAP UNIT	1	EXCEPT P,PC,PU
306	VYQ5606	LENS HOOD UNIT	1	EXCEPT P,PC,PU
307	VPF1166	CAMERA BAG	1	EXCEPT P,PC,PU
308	VPK4552	PACKING CASE	1	GC,GN
308	VYQ5773	PACKING CASE UNIT	1	GK
308	VPK4551	PACKING CASE	1	(DMC-FZ45)
308	VYQ5772	PACKING CASE UNIT	1	PR,GT
309	VPN7080	PAD	1	EXCEPT P,PC,PU
△ 310	VFF0680	CD-ROM (INSTRUCTION BOOK)	1	GC,GN
△ 310	VFF0682	CD-ROM (INSTRUCTION BOOK)	1	GK
△ 310	VFF0681	CD-ROM (INSTRUCTION BOOK)	1	GT
△ 310	VFF0678	CD-ROM (INSTRUCTION BOOK)	1	EB,EF,EG,EP
310	VFF0679	CD-ROM (INSTRUCTION BOOK)	1	EE
△ 310	VFF0677	CD-ROM (INSTRUCTION BOOK)	1	PR
△ 311	VQT2X19	SIMPLIFIED O/I (SPANISH)	1	PR
△ 311	VQT2X30	SIMPLIFIED O/I (ENGLISH/ CHINESE(TRADITIONAL))	1	GC
△ 311	VQT2X31	SIMPLIFIED O/I (ARABIC/PERSIAN)	1	GC
△ 311	VQT2X33	SIMPLIFIED O/I (CHINESE(SIMPLIFIED))	1	GK
△ 311	VQT2X34	SIMPLIFIED O/I (ENGLISH)	1	GN
△ 311	VQT2X32	SIMPLIFIED O/I (CHINESE(TRADITIONAL))	1	GT

Ref.No.	Part No.	Part Name & Description	Pcs	Remarks
△ 311	VQT2X28	SIMPLIFIED O/I (ENGLISH)	1	EB
△ 311	VQT2X29	SIMPLIFIED O/I (RUSSIAN/UKRAINIAN)	1	EE
△ 311	VQT2X27	SIMPLIFIED O/I (FRENCH)	1	EF
△ 311	VQT2X20	SIMPLIFIED O/I (GERMAN/FRENCH)	1	EG
△ 311	VQT2X21	SIMPLIFIED O/I (ITALIAN/DUTCH)	1	EG
△ 311	VQT2X22	SIMPLIFIED O/I (SPANISH/PORTUGUESE)	1	EG
△ 311	VQT2X23	SIMPLIFIED O/I (TURKISH)	1	EG
△ 311	VQT2X24	SIMPLIFIED O/I (SWEDISH/DANISH)	1	EP
△ 311	VQT2X25	SIMPLIFIED O/I (POLISH/CZECH)	1	EP
△ 311	VQT2X26	SIMPLIFIED O/I (HUNGARIAN/FINISH)	1	EP
312	VQC7830	O/I SOFTWARE (ENGLISH/ CHINESE(TRADITIONAL)/ ARABIC/PERSIAN)	1	GC
312	VQC7832	O/I SOFTWARE (CHINESE(SIMPLIFIED))	1	GK
312	VQC7828	O/I SOFTWARE (ENGLISH)	1	GN,EB
312	VQC7831	O/I SOFTWARE (CHINESE(TRADITIONAL))	1	GT
312	VQC7829	O/I SOFTWARE (RUSSIAN/UKRAINIAN)	1	EE
312	VQC7827	O/I SOFTWARE (FRENCH)	1	EF
312	VQC7825	O/I SOFTWARE (GERMAN/FRENCH/ITALIAN/ DUTCH/SPANISH/PORTUGUESE/ TURKISH)	1	EG
312	VQC7826	SUPPLIED SOFTWARE (SWEDISH/DANISH/POLISH/ CZECH/HUNGARIAN/FINISH)	1	EP
312	VQC7824	O/I SOFTWARE (SPANISH/PORTUGUESE)	1	PR
313	VPF1230	BAG, POLYETHYLENE	1	EXCEPT P,PC,PU
314	VFC4453	SHOULDER STRAP	1	EXCEPT P,PC,PU
316	VQL1S66	LABEL	1	EB,GK
317	VQL2C68-1	TAI WAN OPERATING LABEL	1	GT
△ 339	K2CT39A00002	AC CORD W/PLUG	1	GC,EB
△ 340	K2CQ29A00002	AC CORD W/PLUG	1	GC,EE,EF,EG,EP
△ 341	K2CJ29A00003	AC CORD W/PLUG	1	PR
△ 341	K2CJ29A00002	AC CORD W/PLUG	1	GN
△ 342	K2CA29A00021	AC CORD W/PLUG	1	GT
△ 342	K2CA2YY00070	AC CORD W/PLUG	1	GK

# S7. Exploded View

## S7.1. Frame and Casing Section

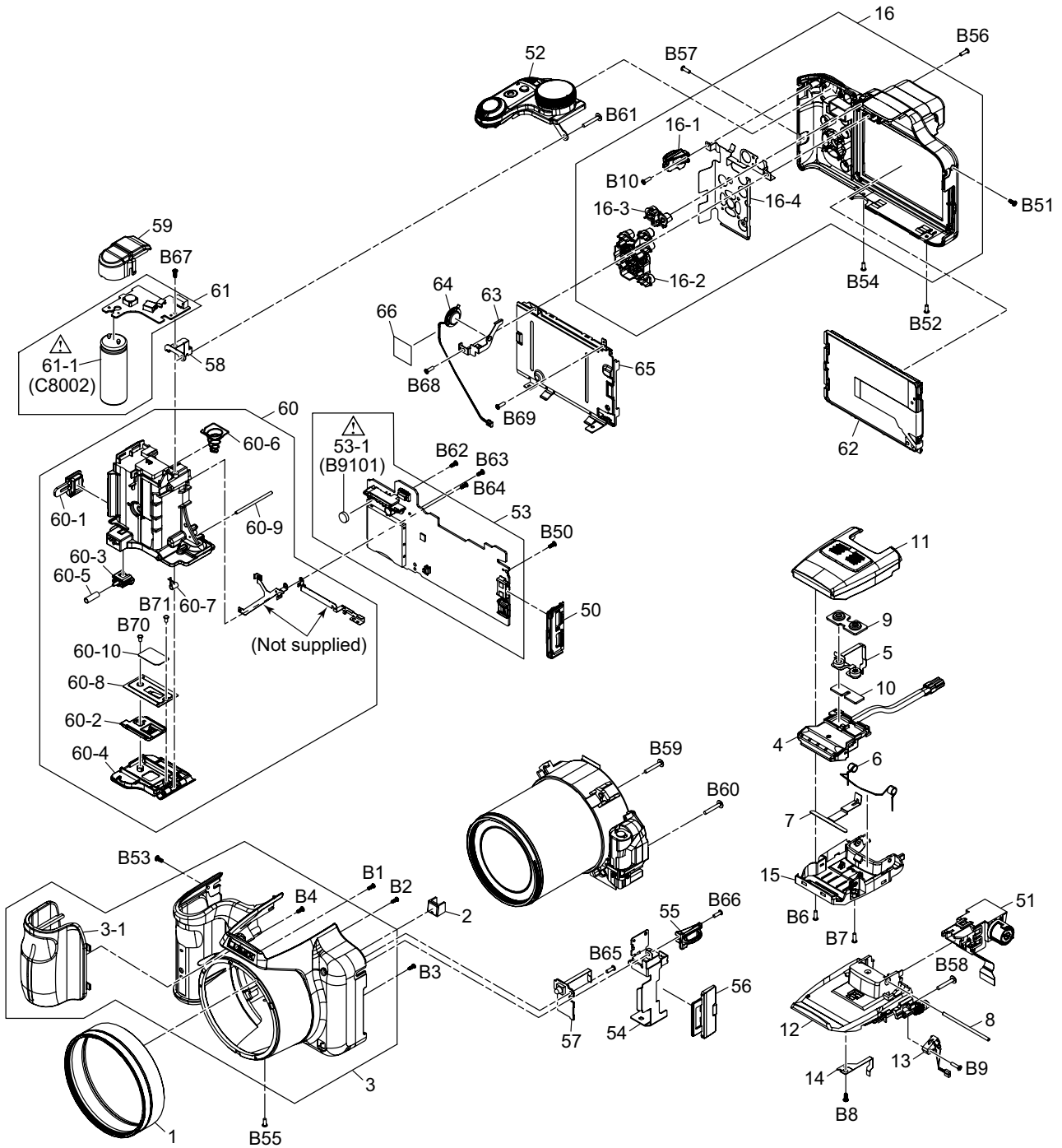

## S7.2. Camera Lens Section

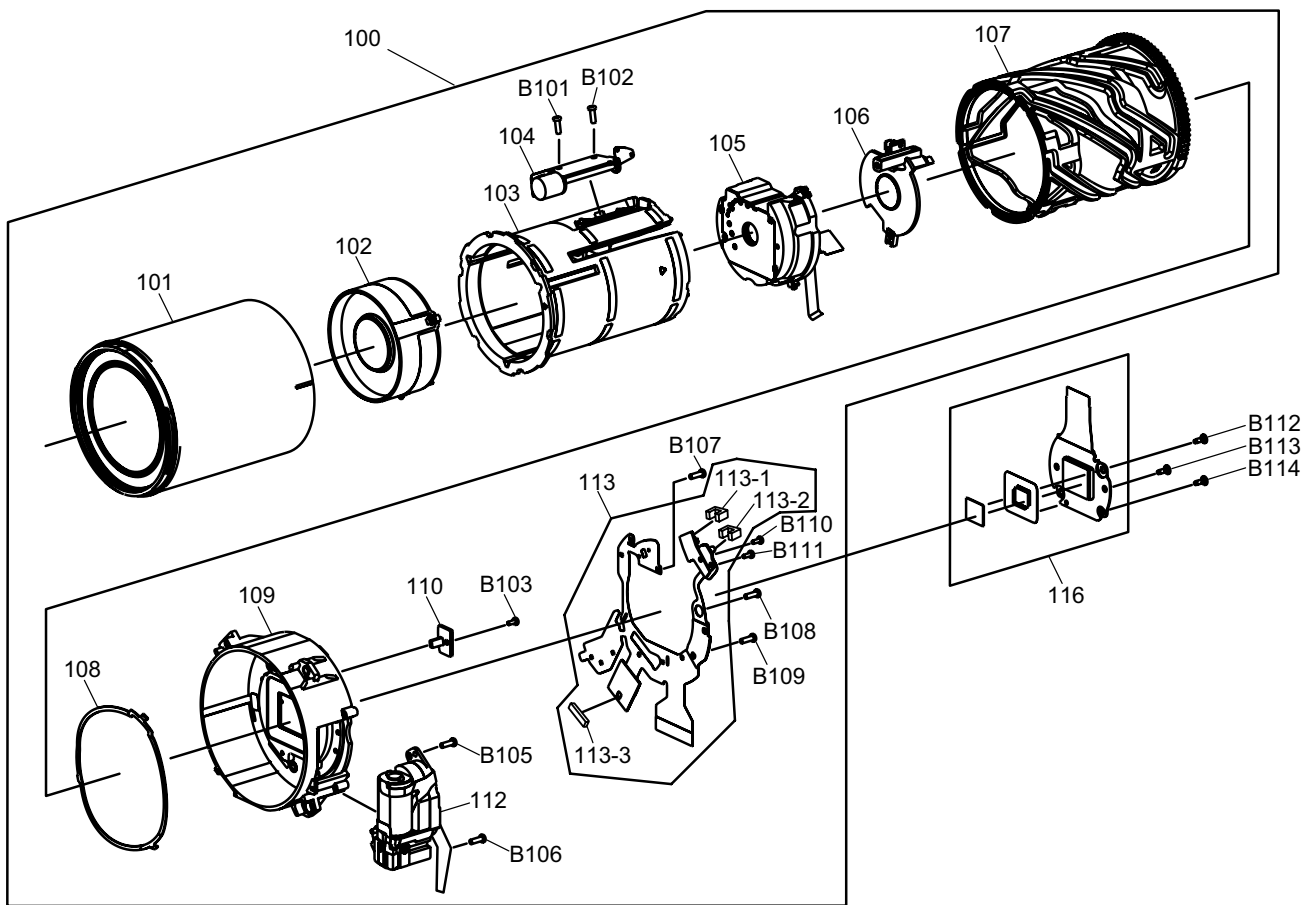

### S7.3. Packing Parts and Accessories Section (1)

