

**Panasonic®**

**ORDER NO.DSC1509019CE**

**B26**

# Service Manual

## Digital Camera

Model No. **DMC-FZ300PP**  
**DMC-FZ300EE**  
**DMC-FZ300EF**  
**DMC-FZ300EG**  
**DMC-FZ300EP**  
**DMC-FZ300GA**  
**DMC-FZ300GC**  
**DMC-FZ300GD**  
**DMC-FZ300GH**  
**DMC-FZ300GK**  
**DMC-FZ300GN**  
**DMC-FZ300GT**  
**DMC-FZ300SG**  
**DMC-FZ330EB**

### Colour

(K).....Black Type

**LUMIX**



**AVCHD™**  
Progressive



**PictBridge**  
USB LAN WLAN  
✓ - ✓



 **WARNING**

This service information is designed for experienced repair technicians only and is not designed for use by the general public. It does not contain warnings or cautions to advise non-technical individuals of potential dangers in attempting to service a product. Products powered by electricity should be serviced or repaired only by experienced professional technicians. Any attempt to service or repair the product or products dealt with in this service information by anyone else could result in serious injury or death.

© Panasonic Corporation 2015.

Unauthorized copying and distribution is a violation of law.

# 1 Safety Precautions

## 1.1 General Guidelines

### 1. IMPORTANT SAFETY NOTICE

- There are special components used in this equipment which are important for safety. These parts are marked by  in the Schematic Diagrams, Circuit Board Layout, Exploded Views and Replacement Parts List. It is essential that these critical parts should be replaced with manufacturer's specified parts to prevent X-RADIATION, shock, fire, or other hazards. Do not modify the original design without permission of manufacturer.
- An Isolation Transformer should always be used during the servicing of AC Adaptor whose chassis is not isolated from the AC power line. Use a transformer of adequate power rating as this protects the technician from accidents resulting in personal injury from electrical shocks. It will also protect AC Adaptor from being damaged by accidental shorting that may occur during servicing.
  - When servicing, observe the original lead dress. If a short circuit is found, replace all parts which have been overheated or damaged by the short circuit.
  - After servicing, see to it that all the protective devices such as insulation barriers, insulation papers shields are properly installed.
  - After servicing, make the following leakage current checks to prevent the customer from being exposed to shock hazards.

## 1.2 Leakage Current Cold Check

- Unplug the AC cord and connect a jumper between the two prongs on the plug.
- Measure the resistance value, with an ohmmeter, between the jumpered AC plug and each exposed metallic cabinet part on the equipment such as screwheads, connectors, control shafts, etc. When the exposed metallic part has a return path to the chassis, the reading should be between 1 M $\Omega$  and 5.2 M $\Omega$ . When the exposed metal does not have a return path to the chassis, the reading must be infinity.

## 1.3 Leakage Current Hot Check (See Figure. 1)

- Plug the AC cord directly into the AC outlet. Do not use an isolation transformer for this check.
- Connect a 1.5 k $\Omega$ , 10 W resistor, in parallel with a 0.15  $\mu$ F capacitor, between each exposed metallic part on the set and a good earth ground, as shown in Figure. 1.
- Use an AC voltmeter, with 1 k $\Omega$ /V or more sensitivity, to measure the potential across the resistor.
- Check each exposed metallic part, and measure the voltage at each point.
- Reverse the AC plug in the AC outlet and repeat each of the above measurements.
- The potential at any point should not exceed 0.75 V RMS. A leakage current tester (Simpson Model 229 or equivalent) may be used to make the hot checks, leakage current must not exceed 1/2 mA. In case a measurement is outside of the limits specified, there is a possibility of a shock hazard, and the equipment should be repaired and rechecked before it is returned to the customer.

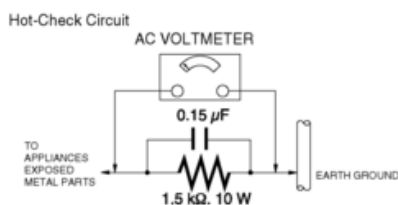

Figure. 1

## 1.4 How to Discharge the E.Capacitor on Flash P.C.B. Unit

### CAUTION:

- Be sure to discharge the E.Capacitor on Flash P.C.B. Unit before disassembling.
- Be careful of the high voltage circuit on Flash P.C.B. Unit when servicing.

### [Discharging Procedure]

- Put the insulation tube on the lead part of resistor (ERG5SJ102:1k $\Omega$  /5W).  
(An equivalent type of resistor may be used.)
- Put the resistor between both terminals of E.Capacitor on the Flash P.C.B. Unit for approx. 5 seconds.

3. After discharging, confirm that the E.Capacitor voltage is lower than 10V by using a voltmeter.

Fig. F1

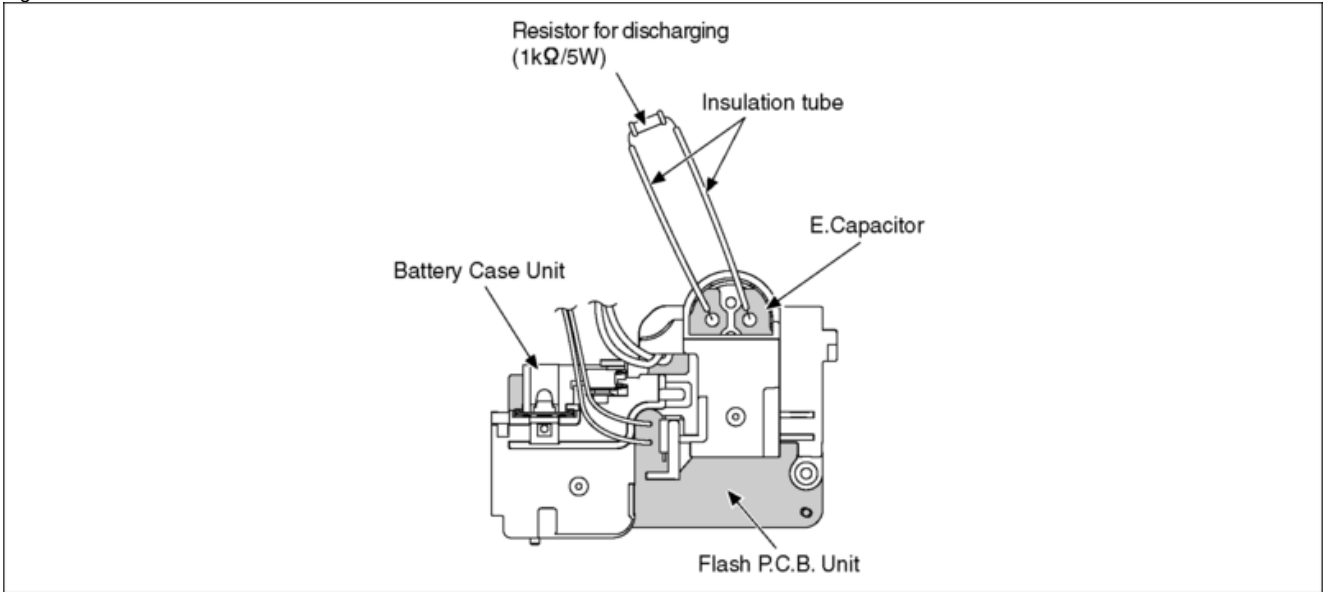

## 2 Warning

### 2.1 Prevention of Electrostatic Discharge (ESD) to Electrostatically Sensitive (ES) Devices

Some semiconductor (solid state) devices can be damaged easily by static electricity. Such components commonly are called Electrostatically Sensitive (ES) Devices.

Examples of typical ES devices are MOS image sensor, IC (integrated circuits) and some field-effect transistors and semiconductor "chip" components.

The following techniques should be used to help reduce the incidence of component damage caused by electrostatic discharge (ESD).



1. Immediately before handling any semiconductor component or semiconductor-equipped assembly, drain off any ESD on your body by touching a known earth ground. Alternatively, obtain and wear a commercially available discharging ESD wrist strap, which should be removed for potential shock reasons prior to applying power to the unit under test.
2. After removing an electrical assembly equipped with ES devices, place the assembly on a conductive surface such as aluminum foil, to prevent electrostatic charge buildup or exposure of the assembly.
3. Use only a grounded-tip soldering iron to solder or unsolder ES devices.
4. Use only an antistatic solder removal device. Some solder removal devices not classified as "antistatic (ESD protected)" can generate electrical charge sufficient to damage ES devices.
5. Do not use freon-propelled chemicals. These can generate electrical charges sufficient to damage ES devices.
6. Do not remove a replacement ES device from its protective package until immediately before you are ready to install it. (Most replacement ES devices are packaged with leads electrically shorted together by conductive foam, aluminum foil or comparable conductive material).
7. Immediately before removing the protective material from the leads of a replacement ES device, touch the protective material to the chassis or circuit assembly into which the device will be installed.

**CAUTION :**

Be sure no power is applied to the chassis or circuit, and observe all other safety precautions.

8. Minimize bodily motions when handling unpackaged replacement ES devices. (Otherwise harmless motion such as the brushing together of your clothes fabric or the lifting of your foot from a carpeted floor can generate static electricity (ESD) sufficient to damage an ES device).

### 2.2 How to Recycle the Lithium Ion Battery (U.S. Only)

<b>ENGLISH</b>		<p>A lithium ion battery that is recyclable powers the product you have purchased. Please call 1-800-8-BATTERY for information on how to recycle this battery.</p>
<b>FRANÇAIS</b>		<p>L'appareil que vous vous êtes procuré est alimenté par une batterie au lithium-ion recyclable. Pour des renseignements sur le recyclage de la batterie, veuillez composer le 1-800-8-BATTERY.</p>

### 2.3 How to Replace the Lithium Battery

#### 2.3.1 Replacement Procedure

1. Remove the Flash P.C.B.. (Refer to Disassembly Procedures.)
2. Unsolder the each soldering point of electric lead terminal for Lithium battery (Ref. No. "B8001" at component side of Flash P.C.B.) and remove the Lithium battery together with electric lead terminal. Then replace it into new one.

**NOTE:**

The Lithium battery includes electric lead terminals.

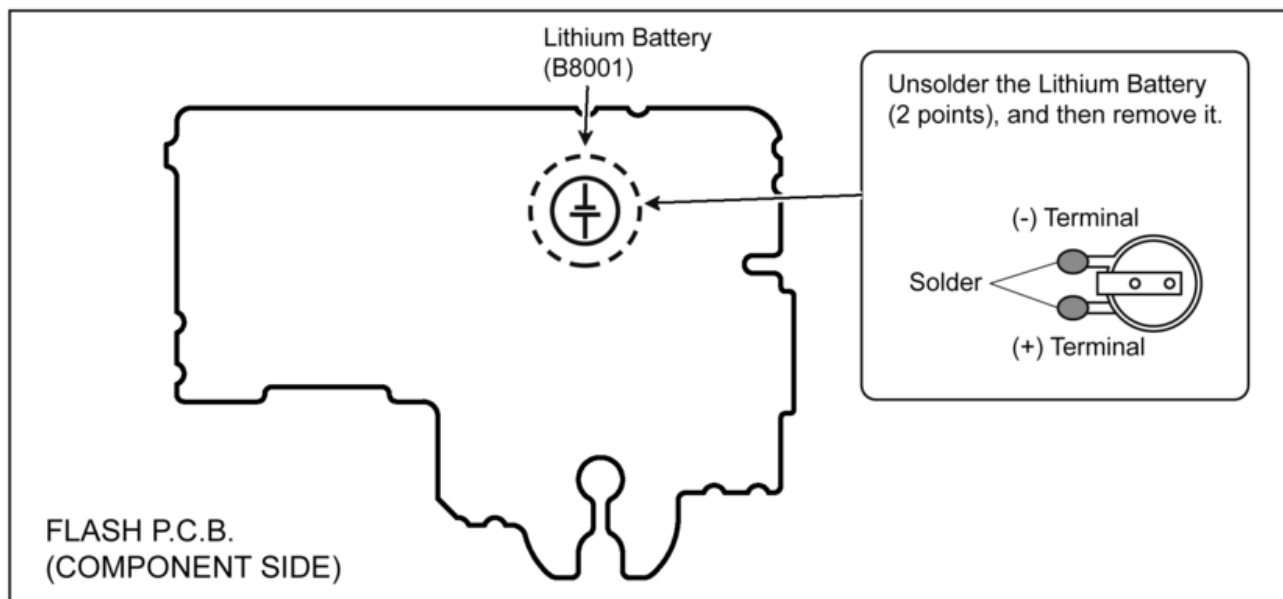
**NOTE:**

This Lithium battery is a critical component.

It must never be subjected to excessive heat or discharge.

It must therefore only be fitted in requirement designed specifically for its use.

Replacement batteries must be of same type and manufacture.

They must be fitted in the same manner and location as the original battery, with the correct polarity contacts observed.

Do not attempt to re-charge the old battery or re-use it for any other purpose.

It should be disposed of in waste products destined for burial rather than incineration.

**(For English)****CAUTION**

Danger of explosion if battery is incorrectly replaced.

Replace only with the same or equivalent type recommended by the manufacturer.

Dispose of used batteries according to the manufacturer's instructions.

**(For German)****ACHTUNG**

Explosionsgefahr bei falschem Anbringen der Batterie. Ersetzen Sie nur mit einem äquivalentem vom Hersteller empfohlenem Typ.

Behandeln Sie gebrauchte Batterien nach den Anweisungen des Herstellers.

**(For French)****MISE EN GARDE**

Une batterie de remplacement inappropriée peut exploser. Ne remplacez qu'avec une batterie identique ou d'un type recommandé par le fabricant. L'élimination des batteries usées doit être faite conformément aux instructions du manufacturier.

**NOTE:**

Above caution is applicable for a battery pack which is for DMC-FZ300/FZ330 series, as well.

## 2.4 Caution for AC Cord (For EB/GC/GH)

**2.4.1 Information for Your Safety****IMPORTANT**

Your attention is drawn to the fact that recording of pre-recorded tapes or discs or other published or broadcast material may infringe copyright laws.

**WARNING**

To reduce the risk of fire or shock hazard, do not expose this equipment to rain or moisture.

**CAUTION**

To reduce the risk of fire or shock hazard and annoying interference, use the recommended accessories only.

**FOR YOUR SAFETY****DO NOT REMOVE THE OUTER COVER**

To prevent electric shock, do not remove the cover. No user serviceable parts inside. Refer servicing to qualified service personnel.

**2.4.2 Caution for AC Mains Lead**

For your safety, please read the following text carefully.

This appliance is supplied with a moulded three-pin mains plug for your safety and convenience.

A 5-ampere fuse is fitted in this plug.

Should the fuse need to be replaced please ensure that the replacement fuse has a rating of 5 amperes and it is approved by ASTA or BSI to BS1362

Check for the ASTA mark or the BSI mark on the body of the fuse.



If the plug contains a removable fuse cover you must ensure that it is refitted when the fuse is replaced.

If you lose the fuse cover, the plug must not be used until a replacement cover is obtained.

A replacement fuse cover can be purchased from your local Panasonic Dealer.

If the fitted moulded plug is unsuitable for the socket outlet in your home then the fuse should be removed and the plug cut off and disposed of safely.

There is a danger of severe electrical shock if the cut off plug is inserted into any 13-ampere socket.

If a new plug is to be fitted please observe the wiring code as shown below.

If in any doubt, please consult a qualified electrician.

**2.4.2.1 Important**

The wires in this mains lead are coloured in accordance with the following code:

Blue	Neutral
Brown	Live

As the colours of the wires in the mains lead of this appliance may not correspond with the coloured markings identifying the terminals in your plug, proceed as follows:

The wire which is coloured BLUE must be connected to the terminal in the plug which is marked with the letter N or coloured BLACK.

The wire which is coloured BROWN must be connected to the terminal in the plug which is marked with the letter L or coloured RED.

Under no circumstances should either of these wires be connected to the earth terminal of the three pin plug, marked with the letter E or the Earth Symbol.

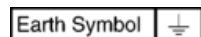
**2.4.2.2 Before Use**

Remove the Connector Cover as follows.

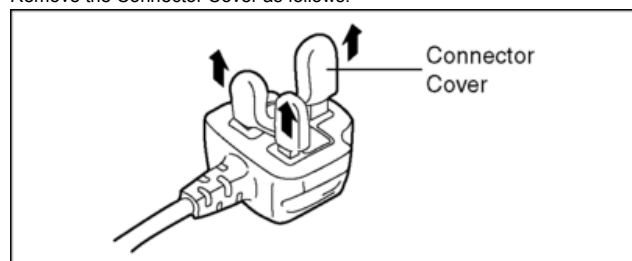
**2.4.2.3 How to Replace the Fuse**

1. Remove the Fuse Cover with a screwdriver.

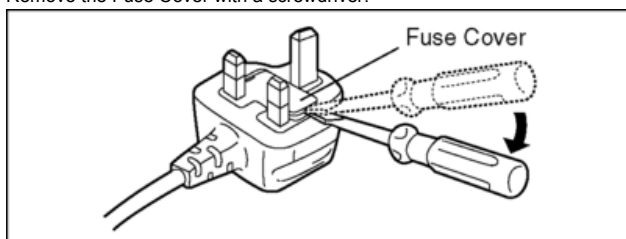

2. Replace the fuse and attach the Fuse cover.

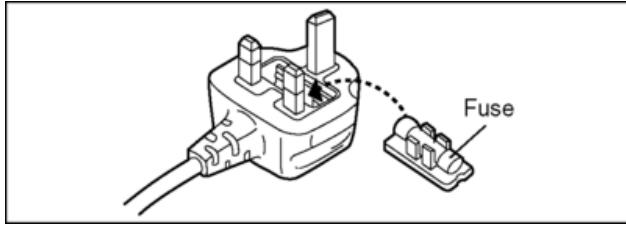



## 3 Service Navigation

### 3.1 Introduction

This service manual contains technical information, which allow service personnel's to understand and service this model.

Please place orders using the parts list and not the drawing reference numbers.

If the circuit is changed or modified, the information will be followed by service manual to be controlled with original service manual.

### 3.2 Important Notice

#### 3.2.1 About Lens Block

The image sensor (MOS) Unit which are connected to the lens unit with 4 screws, after performing the Optical tilt adjustment.

During servicing, if one of MOS Unit fixing screws are loosened, the Optical tilt adjustment must be performed.

(About the Optical tilt adjustment, refer to the "10.3.2. Adjustment Specifications" for details.)

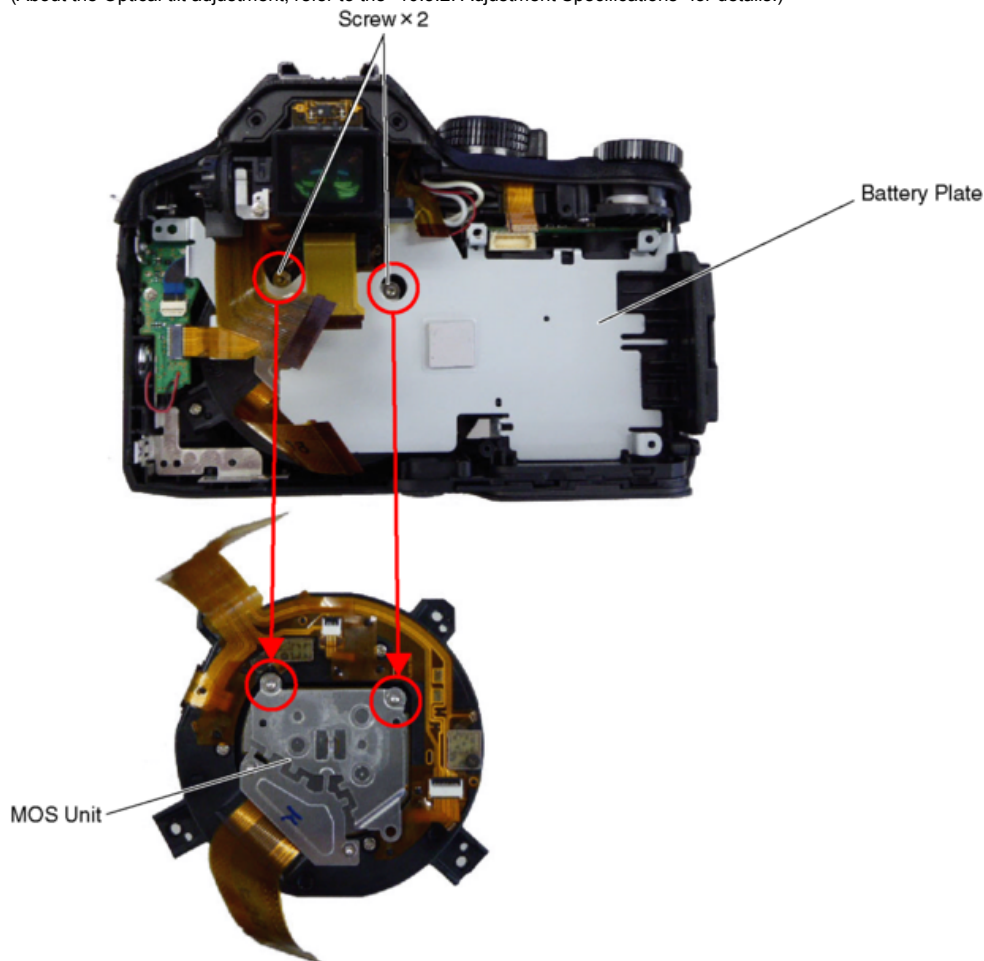

The Optical tilt adjustment can be performed with the Battery Plate attached.

#### 3.2.2 About Venus Engine (IC6001) [Located on the Main P.C.B.]:

The Venus Engine (IC6001) consists of two IC chips (DRAM and Venus) , which are fixed together with solder.

(It's called, "Package On Package" type IC.)

When replacing, always replace in pairs. (Units of service parts: integrated (one pair) state.)

#### **NOTE:**

- During servicing, do not press down hard on the surface of IC6001.

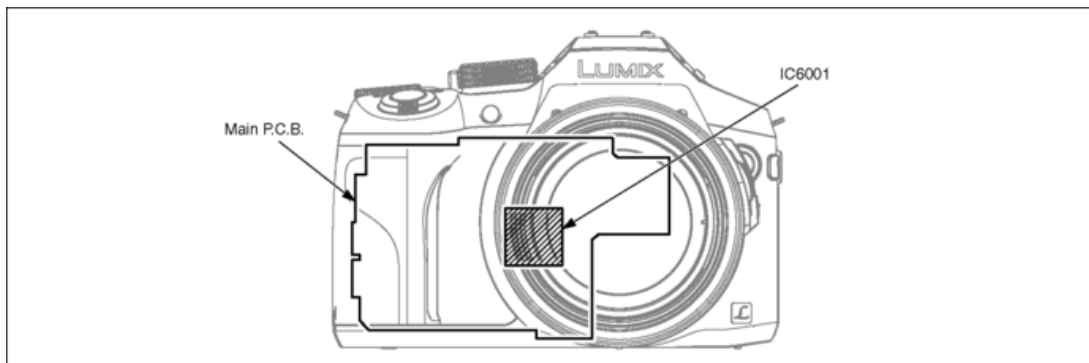

### 3.2.3 About Flexible Cable and Connector

Do not touch carelessly so that the foreign body should not adhere to the terminal part of flexible cable and connector. Wipe off with a clean cloth and the cotton bud, etc. when the terminal part is dirty.

## 3.3 Service Notes

### 3.3.1 About Tilt Sensor Display

The unit has the electronic level function using G (3-axis accelerometer) sensor inside the unit.

#### [Principal of Operation]

1. Movement of "Weight" is detected by capacitance. ----- [A]
2. Each acceleration of the X/Y/Z axis is converted into data and they are output.
3. The VENUS ENGINE converts the data into a horizontal angle and an angle of inclination, and displays them to screen.

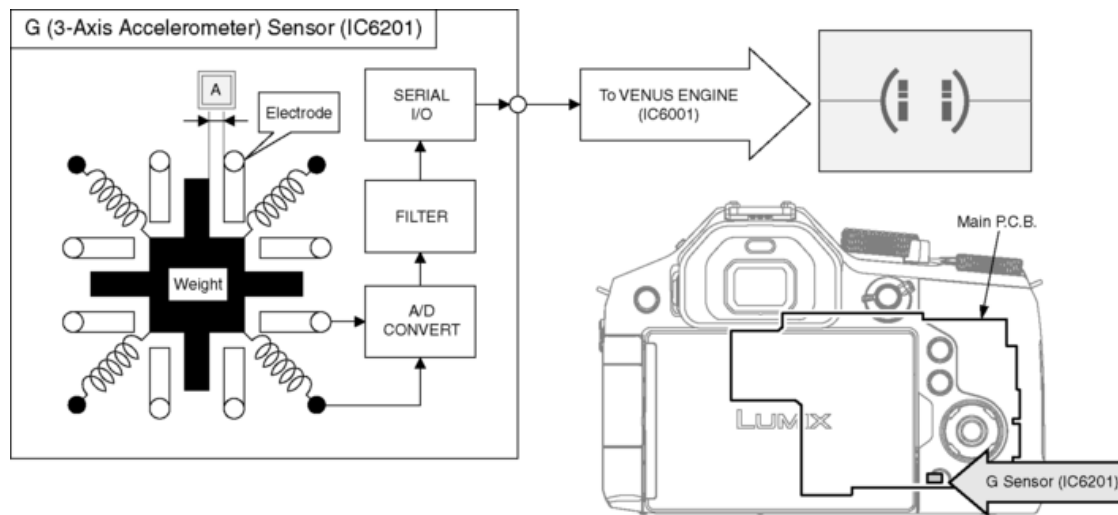

### 3.3.2 About Wi-Fi Function

The page number in this chapter does not show the page number of this service manual.

## Operating the camera by connecting it to a smartphone/tablet

(→260)

- Taking pictures via a smartphone (remote recording)
- Playing back pictures in the camera on a smartphone
- Saving pictures in the camera to a smartphone
- Sending pictures in the camera to social networking services
- Writing the location information on pictures in the camera
- Combining motion pictures recorded with Snap Movie according to your preference on a smartphone



### Connect easily

You can easily set up a direct connection to your smartphone without entering a password.



## Displaying still pictures on a TV (→273)

## Wireless printing (→278)

## Sending pictures to AV device (→279)

Still pictures and motion pictures can be sent to AV device in the home (home AV device).

## Sending pictures to a PC (→280)

## Using WEB services (→282)

Through "LUMIX CLUB", you can send still pictures and motion pictures to social networking services, etc. You can receive still pictures and motion pictures on a PC or a smartphone/tablet using the Cloud Sync. Service.

### 3.3.3 Important Notice of Servicing

This camera unit has the personal information of wireless LAN connection the customer has registered. For the protection of private information, please erase the personal information after the completion of repair by "Initial Settings". In addition, please print out the following documents, and pass to the customer with the camera unit.

#### Printing Material [ Leaflet for Customer ]



## 3.4 General Description About Lead Free Solder (PbF)

The lead free solder has been used in the mounting process of all electrical components on the printed circuit boards used for this equipment in considering the globally environmental conservation.

The normal solder is the alloy of tin (Sn) and lead (Pb). On the other hand, the lead free solder is the alloy mainly consists of tin (Sn), silver (Ag) and copper (Cu), and the melting point of the lead free solder is higher approx.30°C (86°F) more than that of the normal solder.

#### Distinction of P.C.B. Lead Free Solder being used

The letter of "PbF" is printed either foil side or components side on the P.C.B. using the lead free solder. (See right figure)

PbF

#### Service caution for repair work using Lead Free Solder (PbF)

- The lead free solder has to be used when repairing the equipment for which the lead free solder is used. (Definition: The letter of "PbF" is printed on the P.C.B. using the lead free solder.)
- To put lead free solder, it should be well molten and mixed with the original lead free solder.
- Remove the remaining lead free solder on the P.C.B. cleanly for soldering of the new IC.
- Since the melting point of the lead free solder is higher than that of the normal lead solder, it takes the longer time to melt the lead free solder.
- Use the soldering iron (more than 70W) equipped with the temperature control after setting the temperature at 350±30°C (662±86°F).

#### Recommended Lead Free Solder (Service Parts Route.)

- The following 3 types of lead free solder are available through the service parts route.
  - SVKZ000001 ----- (0.3mm 100g Reel)
  - SVKZ000002 ----- (0.6mm 100g Reel)
  - SVKZ000003 ----- (1.0mm 100g Reel)

#### Note

\* Ingredient: tin (Sn) 96.5%, silver (Ag) 3.0%, copper (Cu) 0.5%. (Flux cored)

## 3.5 How to Define the Model Suffix (NTSC or PAL model)

There are nine kinds of DMC-FZ300/FZ330 regardless of the colours.

- a) DMC-FZ300 (Japan domestic model), DMC-FZ300SG
- b) DMC-FZ300PP
- c) DMC-FZ300EF/EG/EP, 330EB
- d) DMC-FZ300EE
- e) DMC-FZ300GN
- f) DMC-FZ300GT
- g) DMC-FZ300GK
- h) DMC-FZ300GD
- i) DMC-FZ300GA/GC/GH

What is the difference is that the "Initial Settings" data which is stored in Flash-ROM mounted on Main P.C.B..

### 3.5.1 Defining methods:

To define the model suffix to be serviced, refer to the nameplate which is putted on the bottom side of the unit.

**a) DMC-FZ300 (Japan domestic model), DMC-FZ300SG**

The nameplate for these models shows the following Safety registration mark.

**b) DMC-FZ300PP**

The nameplate for this model shows the following Safety registration mark.

**c) DMC-FZ300EF/EG/EP, DMC-FZ330EB**

The nameplate for these models shows the following Safety registration mark.

**d) DMC-FZ300EE**

The nameplate for this model shows the following Safety registration mark.

**e) DMC-FZ300GN**

The nameplate for this model shows the following Safety registration mark.

**f) DMC-FZ300GT**

The nameplate for this model shows the following Safety registration mark.

**g) DMC-FZ300GK**

The nameplate for this model shows the following Safety registration mark.

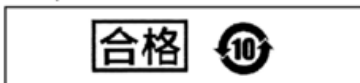
**h) DMC-FZ300GD**

The nameplate for this model shows the following Safety registration mark.

**i) DMC-FZ300GA/GC/GH**

The nameplate for these models does not show any above Safety registration mark.

**NOTE:**

After replacing the Main P.C.B., be sure to achieve adjustment.

**3.5.2 Initial Settings:**

After replacing the Main P.C.B. and/or Flash-ROM, make sure to perform the initial settings after achieving the adjustment by ordering the following procedure in accordance with model suffix of the unit.

**1. Important Notice:**

Before proceeding Initial settings, make sure to read the following CAUTION.

## CAUTION :(Initial Settings)

--- After Replacing The Main P.C.B. and/or Flash-ROM ---

[Except "DMC-FZ300EF/EG/EP and FZ330" models]

- \*. The model suffix can be chosen **JUST ONE TIME**.  
(Effective model suffix : DMC-FZ300 "PP/EE/GA/GC/GD/GH/GK/GN/GT/SG and NONE(JAPAN)")
- \*. Once one of the model suffix has been chosen, the model suffix lists will not be displayed, thus, it can not be changed.

### 2. Procedures:

- Precautions: Read the above "CAUTION" carefully.
- Preparation:  
Attach the fully charged Battery, and insert the memory card (32MB or more).  
Remove the lens cap.
- **Step 1. The Temporary Cancellation of "Initial Settings":**  
Set the [ Mode dial ] to "[ P ](Program AE mode)".  
While pressing [ DISP. ] button, "[ RIGHT ] of Cursor buttons" and [ AF/AE LOCK ] button simultaneously, turn the power on.
- **Step 2. The Cancellation of "Initial Settings":**  
Press the [ Playback ] button in order to enter the [ Playback ] mode.  
Press [ AF/AE LOCK ] button and "[ UP ] of Cursor buttons" simultaneously, then turn the power off.  
The LCD displays the " ! " mark before the unit powers down.

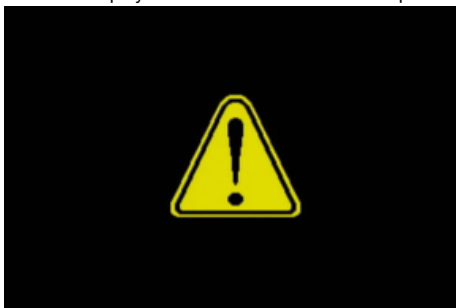

- **Step 3. Turn the Power on:**  
Set the mode dial to "[ P ] (Program AE mode)", then turn the power on.
- **Step 4. Display the Initial Settings:**  
While pressing [ MENU/SET ] button and "[ RIGHT ] of Cursor buttons" simultaneously, turn the power off.  
The "Initial Settings" menu is displayed.  
There are two kinds of "Initial Settings" menu form as follows:  
[ CASE 1. After replacing Main P.C.B. and/or Flash-ROM ]  
[ Except "DMC-FZ300EF/EG/EP and FZ330" models: (SEP0514AA is used as a Main P.C.B.) ]  
When Main P.C.B. has just been replaced, 11 model suffixes are displayed as follows. (Three pages in total)

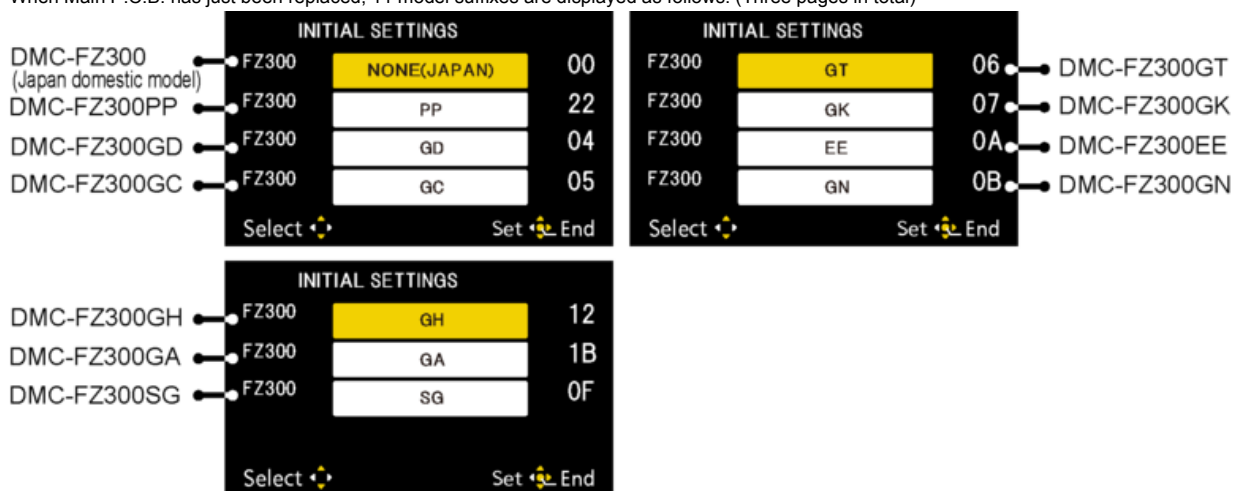

[ Only "DMC-FZ300EF/EG/EP and FZ330" models: SEP0514AB is used as a Main P.C.B. ]  
When Main P.C.B. has just been replaced, only 5 model suffixes are displayed as follows. (Two page 5 in total)



[ CASE 2. Other than "After replacing Main P.C.B. and/or Flash-ROM" ]  
 < Other than "FZ300EF/EG/EP and FZ330" models >      < Only "FZ300EF/EG/EP and FZ330" models >



- **Step 5. Choose the model suffix in "Initial Settings":** (Refer to "CAUTION")

[ **Caution:** After replacing Main P.C.B. and/or Flash-ROM ]

The model suffix can be chosen, **JUST ONE TIME** .

Once one of the model suffix have been chosen, the model suffix lists will not be displayed, thus, it can not be changed.

Therefore, select the area carefully.

Select the area with pressing "[ UP ] / [ DOWN ] of Cursor buttons".

- **Step 6. Set the model suffix in "Initial Settings":**

Press the "[ RIGHT ] of Cursor buttons".

The only set area is displayed, and then press the "[ RIGHT ] of Cursor buttons" after confirmation.

(The unit is powered off automatically.)

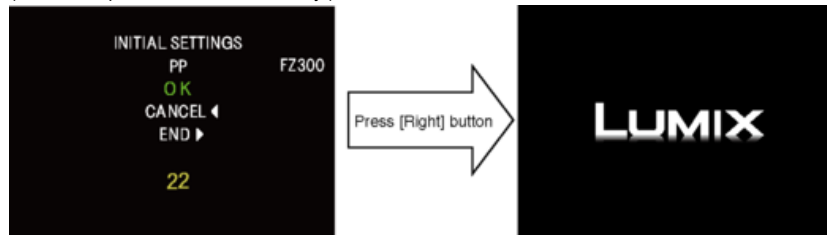

- **Step 7. Confirmation:**

Confirm the display of "PLEASE SET THE CLOCK" in concerned language when the unit is turned on again.

When the unit is connected to PC with USB cable, it is detected as removable media.

As for your reference, major default setting condition is as shown in the following table.

- **Default setting (After "Initial Settings")**

	MODEL	VIDEO OUTPUT	LANGUAGE	DATE	REMARKS
a)	DMC-FZ300 (Japan domestic model)	NTSC	Japanese	Year/Month/Date	
b)	DMC-FZ300PP	NTSC	English	Month/Date/Year	
c)	DMC-FZ300EE	PAL	Russian	Date/Month/Year	
d)	DMC-FZ300EF	PAL	English	Date/Month/Year	
e)	DMC-FZ300EG	PAL	English	Date/Month/Year	
f)	DMC-FZ300EP	PAL	English	Date/Month/Year	
g)	DMC-FZ300GA	PAL	English	Date/Month/Year	
h)	DMC-FZ300GC	PAL	English	Date/Month/Year	
i)	DMC-FZ300GD	NTSC	Korean	Year/Month/Date	
j)	DMC-FZ300GH	PAL	English	Date/Month/Year	
k)	DMC-FZ300GK	PAL	Chinese (simplified)	Year/Month/Date	
l)	DMC-FZ300GN	PAL	English	Date/Month/Year	
m)	DMC-FZ300GT	NTSC	Chinese (simplified)	Year/Month/Date	
n)	DMC-FZ300SG	PAL	English	Date/Month/Year	
o)	DMC-FZ330EB	PAL	English	Date/Month/Year	

# 4 Specifications

The following specification is for DMC-FZ300PP.  
Some specifications may differ depending on model suffix.

## Digital Camera: Information for your safety

<b>Power Source</b>	DC 8.4 V (≈ 8.4 V)
<b>Power Consumption</b>	2.1 W (When recording with monitor) 2.4 W (When recording with viewfinder) 1.6 W (When playing back with monitor) 1.6 W (When playing back with viewfinder)
<b>Camera effective pixels</b>	12,100,000 pixels
<b>Image sensor</b>	1/2.3" MOS sensor, total pixel number 12,800,000 pixels Primary color filter
<b>Lens</b>	Optical 24x zoom f=4.5 mm to 108 mm (35 mm film camera equivalent: 25 mm to 600 mm) Max. Wide: F2.8 to F8.0 (When recording motion pictures: F2.8 to F11) Max. Tele: F2.8 to F8.0 (When recording motion pictures: F2.8 to F11) Filter diameter $\Phi$ 52 mm
<b>Image Stabilizer</b>	Optical method
<b>Focus range</b>	AF: 30 cm (0.98 feet) (Max. Wide) / 2 m (6.6 feet) (Max. Tele) to $\infty$ AF Macro / MF / Intelligent Auto / Motion picture: 1 cm (0.033 feet) (Max. Wide) / 1 m (3.3 feet) (Max. Tele) to $\infty$
<b>Shutter system</b>	Electronic shutter + Mechanical shutter
<b>Minimum Illumination</b>	Approx. 9 lx (when i-Low light is used, the shutter speed is 1/30th of a second)
<b>Shutter speed</b>	Still picture: B (Bulb) (Max. approx. 60 seconds), 60 seconds to 1/4000th of a second (When the mechanical shutter is used), 1 second to 1/16000th of a second (When the electronic shutter is used) Motion picture: 1/25th of a second to 1/16000th of a second (When [FHD/24M/24p] is set in [AVCHD], or [4K/100M/24p] is set in [MP4]), 1/2 second to 1/16000th of a second (When [M] is selected in Creative Video Mode, MF), 1/30th of a second to 1/16000th of a second (Other than the above)



<b>Exposure (AE)</b>	Program AE (P) / Aperture-priority AE (A) / Shutter-priority AE (S) / Manual exposure (M) / AUTO Exposure Compensation (1/3 EV steps, -3 EV to +3 EV)
<b>[Metering Mode]</b>	Multiple/Center weighted/Spot
<b>Monitor</b>	3.0" TFT LCD (3:2) (Approx. 1,040,000 dots) (field of view ratio about 100%) Touch screen
<b>Viewfinder</b>	0.39" OLED Live Viewfinder (4:3) (Approx. 1,440,000 dots) (field of view ratio about 100%) [Magnification approx. 3.88x, 0.7x (35 mm film camera equivalent), with 50 mm lens at infinity; -1.0 m <sup>-1</sup> ] (with diopter adjustment -4.0 to +4.0 diopter)
<b>Flash</b>	Built-in pop up flash AUTO, AUTO/Red-Eye Reduction, Forced ON, Forced ON/Red-Eye Reduction, Slow Sync., Slow Sync./Red-Eye Reduction, Forced OFF
<b>Microphones</b>	Stereo
<b>Speaker</b>	Monaural
<b>Recording media</b>	SD Memory Card / SDHC Memory Card* / SDXC Memory Card* * UHS-I UHS Speed Class 3
<b>Recording file format</b>	
<b>Still picture</b>	RAW/JPEG (based on Design rule for Camera File system, based on Exif 2.3 standard / DPOF corresponding)
<b>Motion picture</b>	AVCHD Progressive / AVCHD / MP4
<b>Audio compression format</b>	AVCHD: Dolby® Digital (2 ch) MP4: AAC (2 ch)
<b>Interface</b>	
<b>Digital</b>	USB 2.0 (High Speed)
<b>Analog video</b>	NTSC Composite
<b>Audio</b>	Audio line output (Monaural)
<b>Terminal</b>	
<b>[REMOTE]</b>	Φ2.5 mm jack
<b>[HDMI]</b>	MicroHDMI Type D
<b>[AV OUT/DIGITAL]</b>	Dedicated jack (8 pin)
<b>[MIC]</b>	Φ3.5 mm jack

<b>Dimensions</b>	Approx. 131.6 mm (W) x 91.5 mm (H) x 117.1 mm (D) [5.18" (W) x 3.60" (H) x 4.61" (D)] (excluding the projection part)
<b>Mass (weight)</b>	With card and battery: Approx. 691 g (1.52 lb) Excluding card and battery: Approx. 640 g (1.41 lb)
<b>Operating temperature</b>	0 °C to 40 °C (32 °F to 104 °F)
<b>Operating humidity</b>	10%RH to 80%RH
<b>Dust-proof and splash-proof</b>	Yes
<b>Language select</b>	[ENGLISH] / [DEUTSCH] / [FRANÇAIS] / [ESPAÑOL] / [PORTUGUÊS] / [ITALIANO] / [繁體中文] / [日本語]

#### ■ Wi-Fi

<b>Compliance standard</b>	IEEE 802.11b/g/n (standard wireless LAN protocol)
<b>Frequency range used (central frequency)</b>	2412 MHz to 2462 MHz (1 to 11 ch)
<b>Encryption method</b>	Wi-Fi compliant WPA™/WPA2™
<b>Access method</b>	Infrastructure mode

#### ■ Battery Charger (Panasonic DE-A79B):

Information for your safety

<b>Input:</b>	~110 V to 240 V, 50/60 Hz, 0.2 A
<b>Output:</b>	== 8.4 V, 0.65 A

#### ■ Equipment mobility:

Movable

#### ■ Battery Pack (lithium-ion) (Panasonic DMW-BLC12PP):

Information for your safety

<b>Voltage/capacity:</b>	7.2 V/1200 mAh
--------------------------	----------------

# 5 Location of Controls and Components

The following description is for DMC-FZ300PP.



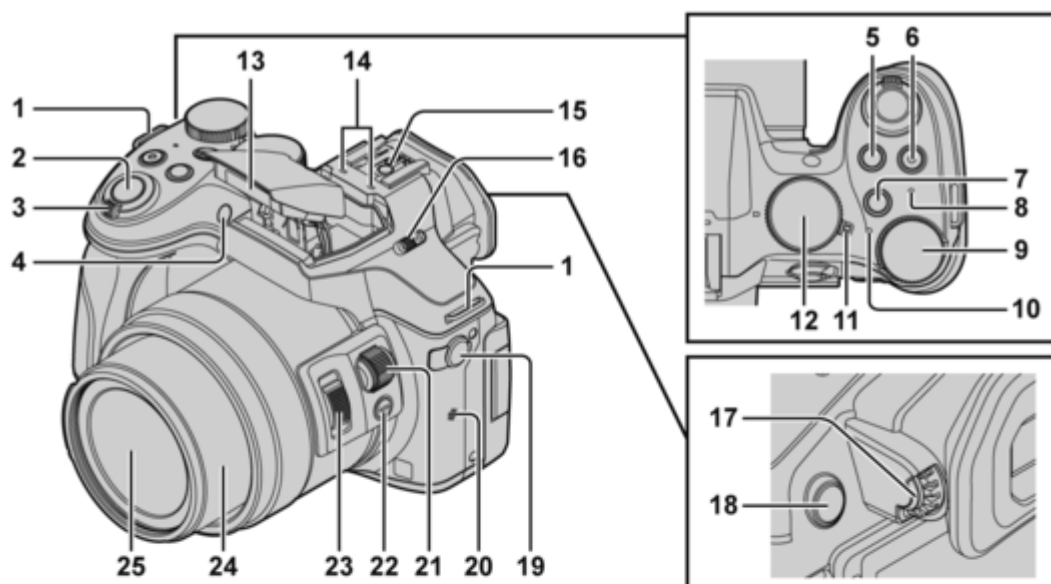

Some descriptions may differ depending on model suffix.

The page number in this chapter does not show the page number of this service manual.

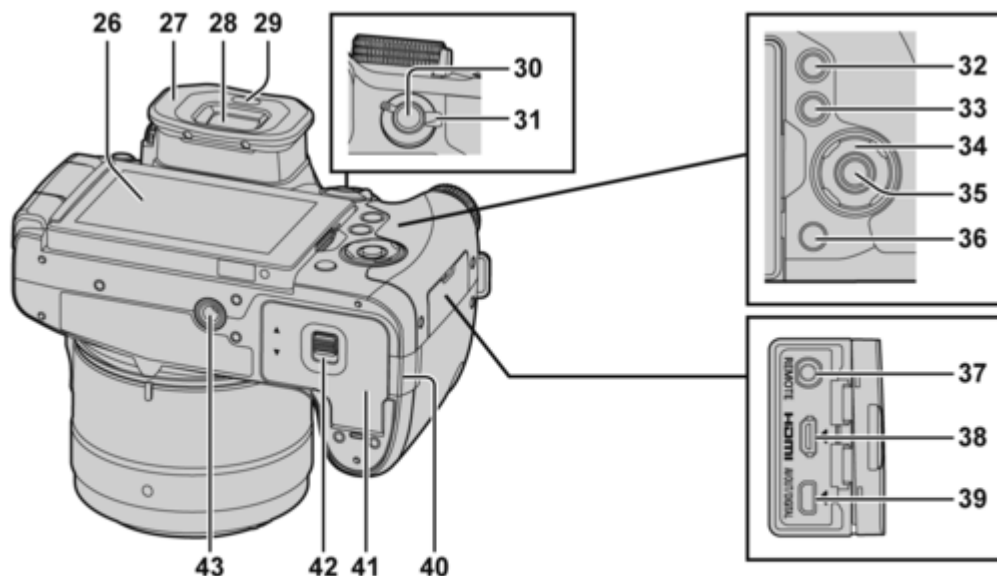

- |           |                                                                                                                                                  |           |                                                                                                                        |
|-----------|--------------------------------------------------------------------------------------------------------------------------------------------------|-----------|------------------------------------------------------------------------------------------------------------------------|
| <b>1</b>  | <b>Shoulder strap eyelet</b> (→15)                                                                                                               | <b>15</b> | <b>Hot shoe</b>                                                                                                        |
| <b>2</b>  | <b>Shutter button</b> (→20)                                                                                                                      | <b>16</b> | <b>Flash open lever</b><br>The flash opens, and recording with the flash becomes possible.                             |
| <b>3</b>  | <b>Zoom lever</b> (→20)                                                                                                                          | <b>17</b> | <b>Dioptr adjustment dial</b> (→24)                                                                                    |
| <b>4</b>  | <b>Self-timer indicator / AF Assist Lamp</b>                                                                                                     | <b>18</b> | <b>[LVF] button</b> (→24) / <b>[Fn4] button</b> (→26)                                                                  |
| <b>5</b>  | <b>[] (Exposure Compensation) button / [Fn1] button</b> (→26) | <b>19</b> | <b>[MIC] socket</b><br>An external microphone (optional) can record higher quality audio than the built-in microphone. |
| <b>6</b>  | <b>Motion picture button</b> (→36)                                                                                                               | <b>20</b> | <b>Speaker</b><br>Be careful not to cover the speaker with your finger. Doing so may make sound difficult to hear.     |
| <b>7</b>  | <b>[Fn2] button</b> (→26)                                                                                                                        | <b>21</b> | <b>Side dial</b> (→22)                                                                                                 |
| <b>8</b>  | <b>Wi-Fi® connection lamp</b>                                                                                                                    | <b>22</b> | <b>Side button</b> (→23)                                                                                               |
| <b>9</b>  | <b>Rear dial</b> (→22)                                                                                                                           | <b>23</b> | <b>Side lever</b> (→20)                                                                                                |
| <b>10</b> | <b>Status indicator</b> (→19)                                                                                                                    | <b>24</b> | <b>Lens barrel</b>                                                                                                     |
| <b>11</b> | <b>Camera [ON/OFF] switch</b> (→19)                                                                                                              | <b>25</b> | <b>Lens</b>                                                                                                            |
| <b>12</b> | <b>Mode dial</b> (→21)<br>Use this to select the recording mode.                                                                                 |           |                                                                                                                        |
| <b>13</b> | <b>Flash</b>                                                                                                                                     |           |                                                                                                                        |
| <b>14</b> | <b>Stereo microphone</b><br>Be careful not to cover the microphone with your finger. Doing so may make sound difficult to record.                |           |                                                                                                                        |



- |           |                                                                                                                                                                                                                                                                                                                                                                                                                                                                                                                                                                                                     |           |                                                                                                                                                                                                                                                                                                                                                                                        |
|-----------|-----------------------------------------------------------------------------------------------------------------------------------------------------------------------------------------------------------------------------------------------------------------------------------------------------------------------------------------------------------------------------------------------------------------------------------------------------------------------------------------------------------------------------------------------------------------------------------------------------|-----------|----------------------------------------------------------------------------------------------------------------------------------------------------------------------------------------------------------------------------------------------------------------------------------------------------------------------------------------------------------------------------------------|
| <b>26</b> | <b>Touch screen / monitor</b> (→19, 24, 50)                                                                                                                                                                                                                                                                                                                                                                                                                                                                                                                                                         | <b>38</b> | <b>[HDMI] socket</b>                                                                                                                                                                                                                                                                                                                                                                   |
| <b>27</b> | <b>Eye cup</b>                                                                                                                                                                                                                                                                                                                                                                                                                                                                                                                                                                                      | <b>39</b> | <b>[AV OUT/DIGITAL] socket</b>                                                                                                                                                                                                                                                                                                                                                         |
| <b>28</b> | <b>Viewfinder</b> (→24)                                                                                                                                                                                                                                                                                                                                                                                                                                                                                                                                                                             | <b>40</b> | <b>DC coupler cover</b> (→17) <ul style="list-style-type: none"> <li>• Always use a genuine Panasonic AC adaptor (DMW-AC10PP: optional).</li> <li>• When using an AC adaptor, ensure that the Panasonic DC coupler (DMW-DCC8: optional) and AC adaptor (DMW-AC10PP: optional) are used.</li> <li>• When using an AC adaptor, use the AC cable supplied with the AC adaptor.</li> </ul> |
| <b>29</b> | <b>Eye sensor</b> (→24)                                                                                                                                                                                                                                                                                                                                                                                                                                                                                                                                                                             | <b>41</b> | <b>Card/Battery door</b> (→17)                                                                                                                                                                                                                                                                                                                                                         |
| <b>30</b> | <b>[AF/AE LOCK] button</b>                                                                                                                                                                                                                                                                                                                                                                                                                                                                                                                                                                          | <b>42</b> | <b>Release lever</b> (→17)                                                                                                                                                                                                                                                                                                                                                             |
| <b>31</b> | <b>Focus mode lever</b> (→21)                                                                                                                                                                                                                                                                                                                                                                                                                                                                                                                                                                       | <b>43</b> | <b>Tripod mount</b> <p>Do not attach this unit to tripods that have screws with a length of 5.5 mm (0.22 inch) or more. Doing so may damage this unit or the unit may not be secured properly on the tripod.</p>                                                                                                                                                                       |
| <b>32</b> | <b>[▶] (Playback) button</b> (→38)                                                                                                                                                                                                                                                                                                                                                                                                                                                                                                                                                                  |           |                                                                                                                                                                                                                                                                                                                                                                                        |
| <b>33</b> | <b>[DISP.] button</b><br>Use this to change display.                                                                                                                                                                                                                                                                                                                                                                                                                                                                                                                                                |           |                                                                                                                                                                                                                                                                                                                                                                                        |
| <b>34</b> | <b>Cursor button</b> <ul style="list-style-type: none"> <li>• Selection of items or setting of values etc., is performed.</li> <li>• In this manual, the button that is to be used is indicated by ▲▼◀▶.</li> </ul>  <p>[ISO] (ISO sensitivity) (▲)<br/> [WB] (White Balance) (▶)<br/> [] (Drive Mode) (▼) (→32)<br/> [] (AF Mode) (◀)</p> |           |                                                                                                                                                                                                                                                                                                                                                                                        |
| <b>35</b> | <b>[MENU/SET] button</b>                                                                                                                                                                                                                                                                                                                                                                                                                                                                                                                                                                            |           |                                                                                                                                                                                                                                                                                                                                                                                        |
| <b>36</b> | <b>[Q.MENU /▶] (Delete/Cancel) button</b><br>(→26, 40) /<br><b>[Fn3] button</b> (→26)                                                                                                                                                                                                                                                                                                                                                                                                                            |           |                                                                                                                                                                                                                                                                                                                                                                                        |
| <b>37</b> | <b>[REMOTE] socket</b>                                                                                                                                                                                                                                                                                                                                                                                                                                                                                                                                                                              |           |                                                                                                                                                                                                                                                                                                                                                                                        |

## 6 Service Mode

### 6.1 Error Code Memory Function

#### 1. General description

This unit is equipped with history of error code memory function, and can be memorized 16 error codes in sequence from the latest. When the error is occurred more than 16, the oldest error is overwritten in sequence.

The error code is not memorized when the power supply is shut down forcibly (i.e., when the unit is powered on by the battery, the battery is pulled out) The error code is memorized to Flash-ROM when the unit has just before powered off.

#### 2. How to display

The error code can be displayed by ordering the following procedure:

##### o Preparation

Attach the fully charged Battery, and insert the memory card (32MB or more).

Remove the lens cap.

##### o Step 1. The Temporary Cancellation of "Initial Settings":

Set the [ Mode dial ] to "[ P ](Program AE mode)".

While pressing [ DISP. ] button, "[ RIGHT ] of Cursor buttons" and [ AF/AE LOCK ] button simultaneously, turn the power on.

##### o Step 2. Execute the Error Code Display Mode:

Press [ MENU/SET ] button, "[ LEFT ] of Cursor buttons" and [ AF/AE LOCK ] button simultaneously with the step 1 condition.

The display is changed as shown below when the above buttons are pressed simultaneously.

Normal display → Error code display → Camera information display → Normal display → .....

Example of Error Code Display

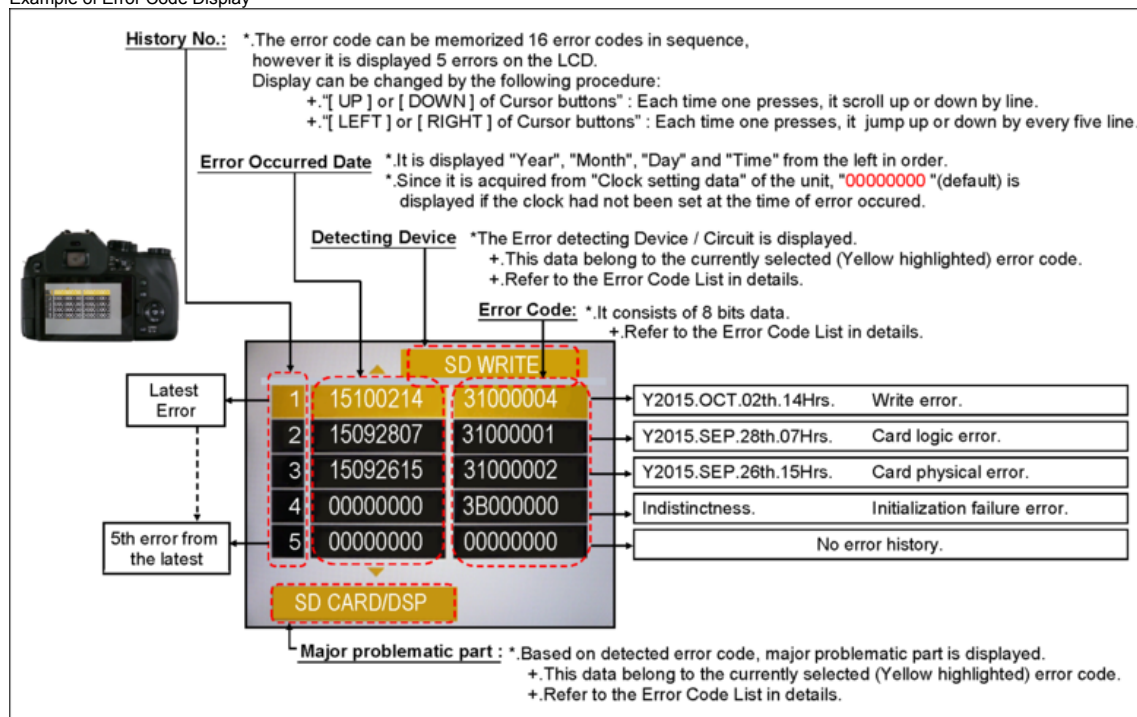

##### o Error Code List

The error code consists of 8 bits data and it shows the following information.

Attribute	Main item	Sub item	Error code		Contents (Upper) Check point (Lower)	Error Indication	
			High 4 bits	Low 4 bits		Detecting device	Part/Circuit
LENS	Lens drive	Focus	1C*0	0701	HP High detect error (Focus encoder always detects High, and not becomes Low) Mechanical lock, FP9005-(26) signal line or IC6001 (VENUS ENGINE)	FOCUS L	LENS FPC/DSP
				0702	HP Low detect error (Focus encoder always detects Low, and not becomes High) Mechanical lock, FP9005-(26) signal line or IC6001 (VENUS ENGINE)		
		Zoom	0710	Collapsible barrel Low detect error (Collapsible barrel encoder always detects High.) Mechanical lock, FP9005-(1) signal line or IC6001	ZOOM L	ZOOMm/LENSu	

				(VENUS ENGINE)		
			0720	Collapsible barrel High detect error (Collapsible barrel encoder always detects Low.) Mechanical lock, FP9005-(1) signal line or IC6001 (VENUS ENGINE)	ZOOM H	
			0730	Zoom motor sensor error. (Initialized or Terminated) Mechanical lock, FP9005-(4), (15) signal line or IC6001 (VENUS ENGINE)	ZOOM ENC	
			0740	Zoom motor sensor error. (During monitor mode.) Mechanical lock, FP9005-(4), (15) signal line or IC6001 (VENUS ENGINE)		
			0750	Zoom motor sensor error. (During monitor mode with slow speed.) Mechanical lock, FP9005-(4), (15) signal line or IC6001 (VENUS ENGINE)		
			0760	Detection of zoom misregistration by impact such as fails. Lens Unit	(No indication)	(No indication)
		OIS	1000	PSD (X) error. Hall element (X axis) position detect error in OIS unit. OIS Unit	OIS X	LENSu NG
			2000	PSD (Y) error. Hall element (Y axis) position detect error in OIS unit. OIS Unit	OIS Y	
			3000	GYRO (X) error. Gyro (IC7101 : X axis) detect error on Main P.C.B. IC7101 (Gyro element) or IC6001 (VENUS ENGINE)	GYRO X	GYRO NG
			4000	GYRO (Y) error. Gyro (IC7101 : Y axis) detect error on Main P.C.B. IC7101 (Gyro element) or IC6001 (VENUS ENGINE)	GYRO Y	
			5000	GYRO (R) error, Gyro (IC7101 : R axis) detect error on Main P.C.B. IC7101 (Gyro element) or IC6001 (VENUS ENGINE)	GYRO R	
			6000	Drive voltage (X) error. LENS Unit, LENS flex breaks, IC6001(VENUS ENGINE) AD value error, etc.	OISX REF	LENSu/LENS FPC
			7000	Drive voltage (Y) error. LENS Unit, LENS flex breaks, IC6001(VENUS ENGINE) AD value error, etc.	OISY REF	
			8000	OIS GYRO - Digital communication error. IC7101 (Gyro element) or IC6001 (VENUS ENGINE)	(No indication)	(No indication)
		Lens	18*1	0000 Power ON time out error. Lens drive system	LENS DRV	LENSu
			18*2	0000 Power OFF time out error. Lens drive system		
	Adj.History	OIS	1D*0	2000 OIS adj. Yaw direction amplitude error (small) 3000 OIS adj. Pitch direction amplitude error (small) 4000 OIS adj. Yaw direction amplitude error (large) 5000 OIS adj. Pitch direction amplitude error (large) 8000 OIS adj. Yaw direction off set error 9000 OIS adj. Pitch direction off set error A000 OIS adj. Yaw direction gain error B000 OIS adj. Pitch direction gain error C000 OIS adj. Yaw direction position sensor error D000 OIS adj. Pitch direction position sensor error E000 OIS adj. other error	OIS ADJ	OIS ADJ
HARD	FLASH	Flash	28*0	0000 Flash charging capacitor did not been fully charged within 20 seconds	STRB CHG	FLASH P.C.B./FPC
	FLASH ROM	Data Area	2B*0	0001 IC6003 (Flash-ROM) data reading error is detected when the unit turns ON 0002 IC6003 (Flash-ROM) data writing error is detected when the unit turns OFF	FROM RE FROM WR	FROM FROM
		Program Area		0005 Firmware update error	(No indication)	(No indication)
SOFT	CPU	Reset	30*0	0001 System error (NMI reset)   0007	NMI RST	MAIN P.C.B.
	Recording Media	Memory card	31*0	0002 Memory card physical error During formatting the memory card, there is no response from the memory card If the mini-SD memory card is used, check the SD memory card adaptor 0004 Memory card writing error Check the memory card. It might be damage one.	SD CARD SD WRITE	SD CARD/DSP
	Recording	Motion Image Recording	3F*0	0001 File time out error in recording motion image 0002 File data cue send error in recording motion image	(No indication)	(No indication)
Wi-Fi			3211	**02 Wi-Fi related errors:   *Generally, above are unable to specified the, which cannot be used for malfunction diagnosis. **0C		

**Important notice about "Error Code List"****1) About "\*" indication:**

The third digit from the left is different as follows.

- In case of 0 (example: 18 001000)  
When the third digit from the left shows "0", this error occurred under the condition of Initial Settings has been completed.  
It means that this error is occurred basically at user side.
  
- In case of 8 (example: 18 801000)  
When the third digit from the left shows "8", this error occurred under the condition of Initial Settings has been released.  
(Example; Factory assembling-line before unit shipment, Service mode etc.)  
It means that this error is occurred at service side.

**2) About "?" indication: ("18\*0 0?01" to "18\*0 0?60"):**

The third digit from the right shows one of the hexadecimal ("0" to "F") character.

**○ Step 3. How to exit from Error Code display mode:**

Simply, turn the power off. (Since Error code display mode is executed under the condition of temporary cancellation of "Initial Settings", it wake up with normal condition when turn off the power.)

**NOTE:**

The error code can not be initialized.

# 7 Troubleshooting Guide

## 7.1 Wi-Fi Module (Flash P.C.B. Unit)

### 7.1.1 How to Remove Wi-Fi Password Protection

To prevent incorrect operation or use of the Wi-Fi function by a third party and to protect saved personal information, this unit protects the Wi-Fi function with a password.

It is unable to service with password locked condition. When accepting for repair, the unit has been set the Wi-Fi password by customer, run the [Reset Wi-Fi Settings] for removing Wi-Fi password, then check the operation.

#### [Reset Procedure of Wi-Fi Settings]

- 1) Press the [ MENU/SET ] button, and select the [ SETUP ] mode by Cursor buttons, then press the [ MENU/SET ] button.
- 2) Select [ Reset Wi-Fi Settings ] by Cursor buttons, then press the [ MENU/SET ] button.
- 3) Select [ YES ] and press the [ MENU/SET ] button.

(The [ Reset Wi-Fi Settings ] performs not only resetting Wi-Fi Password but also resetting other all Wi-Fi Settings.)

### 7.1.2 Checking of Trouble Caused by Wi-Fi Module or Not

The Wi-Fi module works properly if the wireless access point (broadband router) name (SSID) in use is displayed on a screen of [Manual Connection].

#### (Primary Confirmation)

Confirm that the wireless access point (broadband router) works properly.

#### (Procedure)

- 1) Press [ Wi-Fi ] button.
- 2) Select [ New Connection ] in [ Wi-Fi ] menu.
- 3) Select optional function in [ select a function ] menu, then select [ Direct ] in [ Select connection method ] menu.
- 4) Select [ Manual Connection ] in [ Select connection method ] menu.
- 5) The Wi-Fi module works properly if the wireless access point (broadband router) name (SSID) in use is displayed.









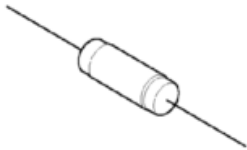
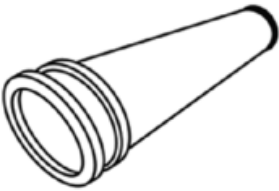
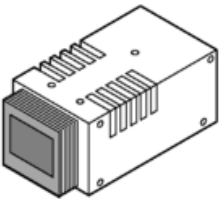

\*Change the Flash P.C.B. Unit, when the above checking detected the abnormal of Wi-Fi module.

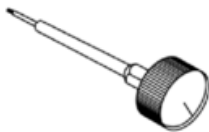
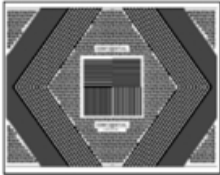

## 8 Service Fixture & Tools

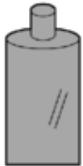
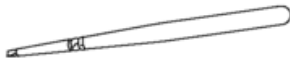
### 8.1 Service Fixture and Tools

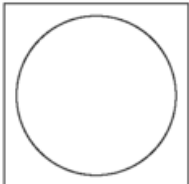
The following Service Fixture and tools are used for checking and servicing this unit.

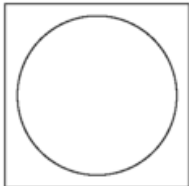
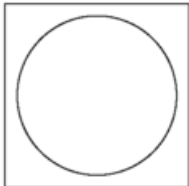
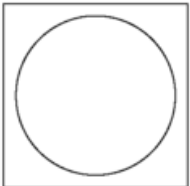
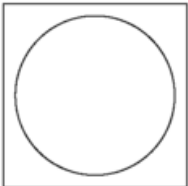
Resistor for Discharging (1k $\Omega$ /5W) <b>ERG5SJ102</b>		COLLIMATOR (built-in Focus Chart) <b>RFKZ0422</b>		LIGHT BOX (with DC Cable) <b>RFKZ0523</b>			
 * An equivalent type of resistor may be used.							
Lens Cleaning Kit (BK) <b>VFK1900BK</b>		Torque Driver <b>RFKZ0542</b>		Diffuser <b>RFKZ0591</b>			
 * Only supplied as 10 set/box.							
Driver (for Optical Axis Adjustment) <b>RFKZ0569</b>		Optical Axis Adjustment Chart <b>RFKZ0570</b>		Camera stand <b>RFKZ0333J</b>			
 * T4 Torx type							
Grease (for Lens) <b>RFKZ0472</b>		Screw locking glue <b>RFKZ0573</b>		Silicon chips <b>RFKZ0478</b>			
							
Gray Card <b>RFKZ0506</b>		ND Filter (ND0.3) <b>RFKZ0513</b>		ND Filter (ND0.6) <b>VFK1164ND06</b>		ND Filter (ND0.9) <b>VFK1164ND09</b>	
							
CC Filter (CC-C7.5) <b>RFKZ0511</b>		CC Filter (CC-Y10) <b>RFKZ0512</b>		LB Filter (LBB2) <b>RFKZ0520</b>		LB Filter (LBB8) <b>RFKZ0521</b>	
							

## 8.2 When Replacing the Main P.C.B.

After replacing the Main P.C.B., be sure to achieve adjustment.

## 8.3 Service Position

This Service Position is used for checking and replacing parts. Use the following Extension cables for servicing.

Table S1 Extension Cable List

No.	Parts No.	Connection	Form
1	VFK1870	PS9001(MAIN) ↔ PP8001(FLASH)	30pin B to B
2	VFK2024	FP9005(MAIN) ↔ LENS UNIT	51pin / 0.3 FFC
3	RFKZ0392	FP9007(MAIN) ↔ REAR OPERATION UNIT	14pin / 0.5 FFC
4	RFKZ0626	FP9002(MAIN) ↔ TOP CASE UNIT	21pin / 0.3 FFC
5	RFKZ0477	FP9003(MAIN) ↔ HINGE FPC UNIT-FP4101(LCD IF)	45pin / 0.3 FFC
6	VFK1716	FP9006(MAIN) ↔ MULTI FPC UNIT-TOP CASE UNIT	25pin / 0.3 FFC
7	RFKZ0631	FP9004(MAIN) ↔ JOINT FPC-FP9301(MIC JACK)/ SIDE OPERATION UNIT/ FRONT CASE UNIT	16pin / 0.4 FFC

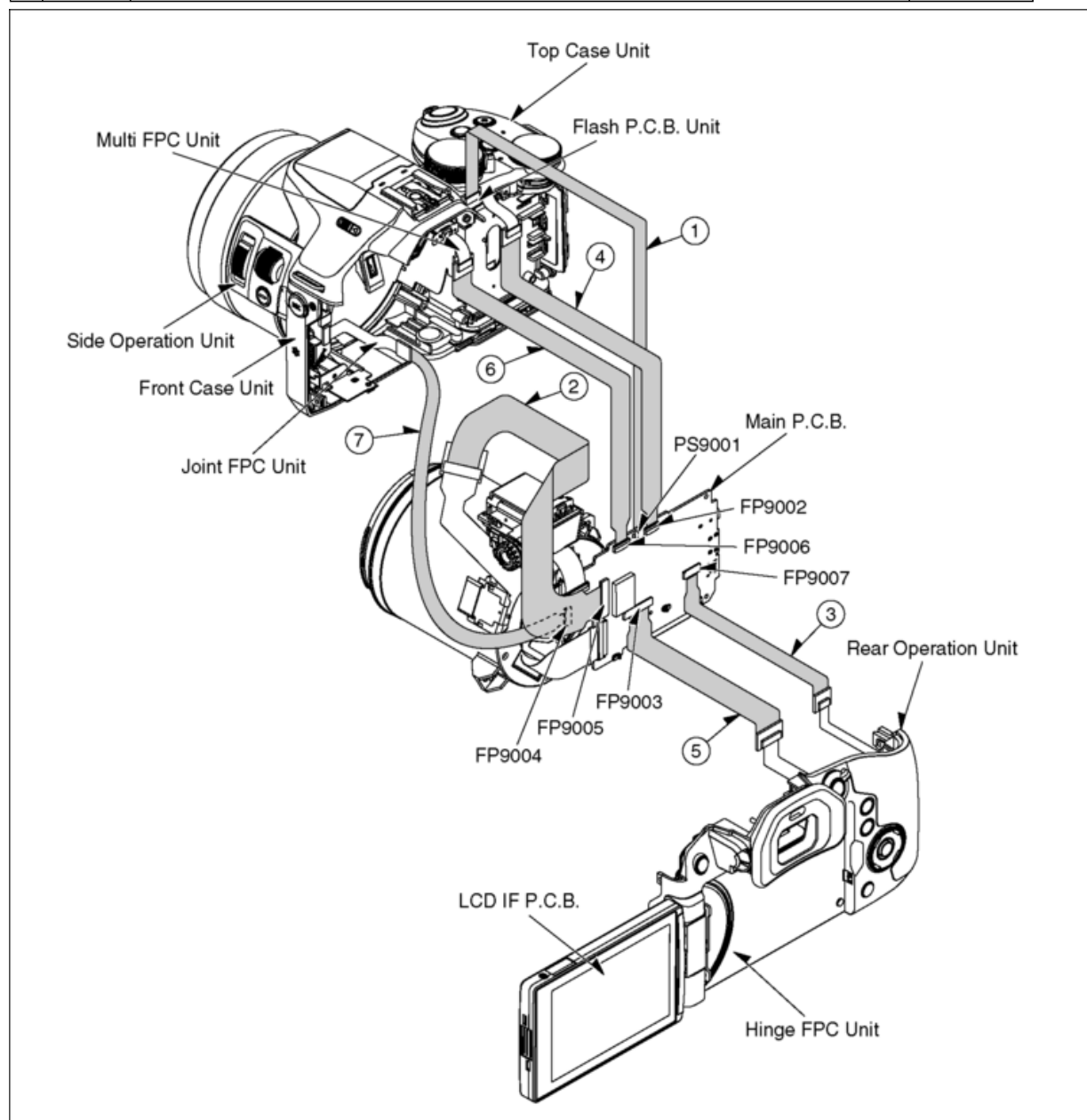

**CAUTION** (When servicing Flash P.C.B. Unit)

1. Be sure to discharge the E.Capacitor on Flash P.C.B. Unit.  
Refer to "How to Discharge the E.Capacitor on Flash P.C.B. Unit."  
The E.Capacitor voltage is not lowered soon even if the AC Cord is unplugged or the battery is removed.
2. Be careful of the high voltage circuit on Flash P.C.B. Unit.
3. DO NOT allow other parts to touch the high voltage circuit on Flash P.C.B. Unit

# 9 Disassembly and Assembly Instructions

## 9.1 Disassembly Flow Chart

This is a disassembling chart.

When assembling, perform this chart conversely.

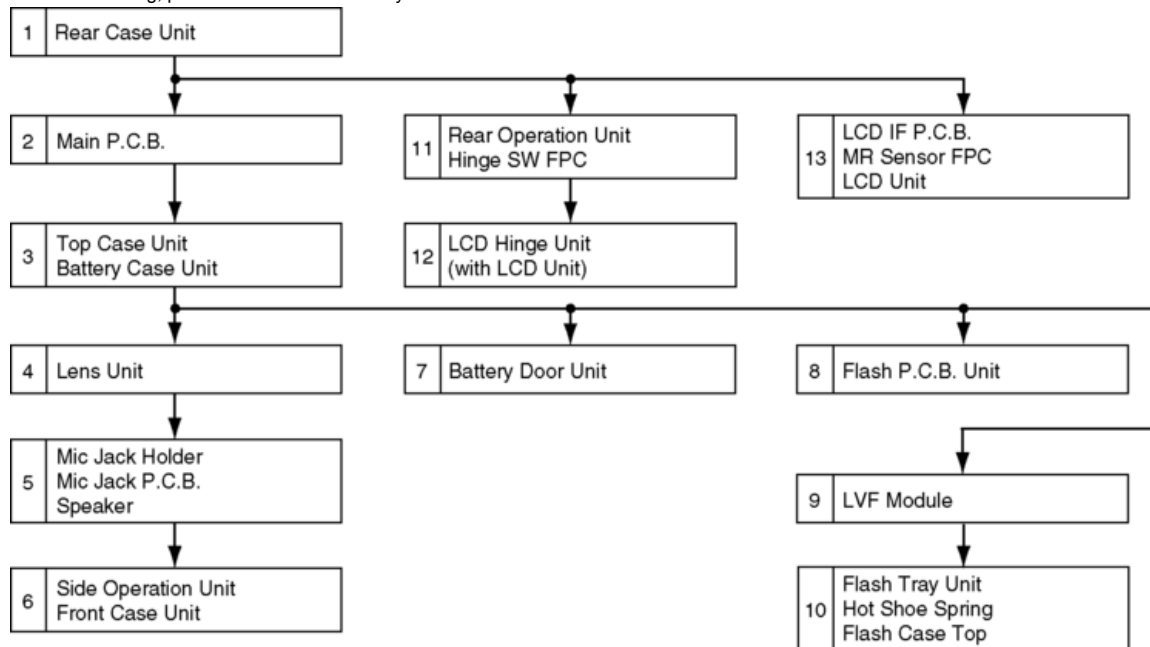

## 9.2 P.C.B. Location

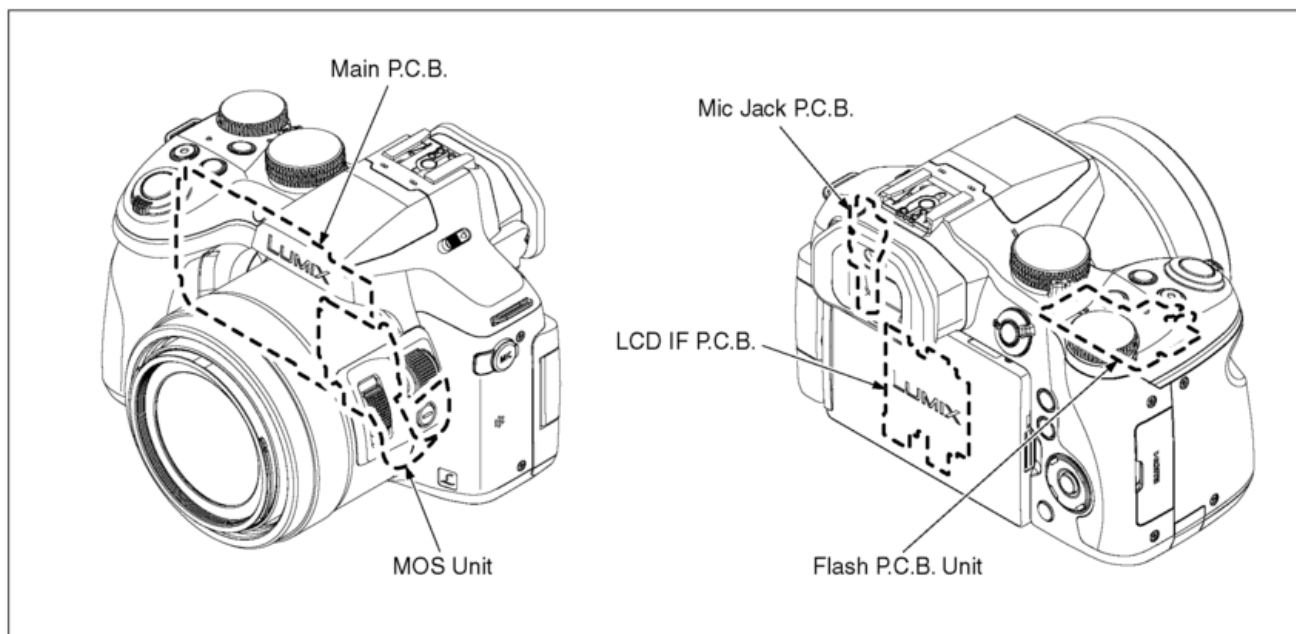

## 9.3 Disassembly Procedure

No.	Item	Fig.	Removal
1	Rear Case Unit	(Fig. D1)	Memory Card Battery

			Screw (A) × 3
			Screw (B) × 3
			Screw (C) × 3
		(Fig. D2)	Locking tab (A) × 2
			Locking tab (B) × 2
			Locking tab (C) × 2
			Locking tab (D) × 2
			Eye Cap Unit
			Screw (D) × 2
		(Fig. D3)	When Installing
		(Fig. D4)	Locking tab × 3
			Rear Grip
			Screw (E) × 2
		(Fig. D5)	FP9003 (Flex)
			FP9007 (Flex)
			Rear Case Unit
2	Main P.C.B.	(Fig. D6)	Screw (F) × 4
			FP9001 (Flex)
			FP9002 (Flex)
			FP9004 (Flex)
			FP9005 (Flex)
			FP9006 (Flex)
			FP9009 (Flex)
			PS9001 (Connector)
			Main P.C.B.
		(Fig. D7)	When Replacing
3	Top Case Unit Battery Case Unit	(Fig. D8)	Screw (G) × 1
			Locking tab × 2
			Battery Plate (with Thermal Sheet C)
		(Fig. D9)	Screw (H) × 1
			Screw (I) × 1
			Screw (J) × 1
			Front Grip
		(Fig. D10)	Screw (K) × 4
			Screw (L) × 2
			Top Case Unit
			Battery Case Unit
		(Fig. D11)	When Installong
		(Fig. D12)	
4	Lens Unit	(Fig. D13)	Screw (M) × 4
			Lens Unit
5	Mic Jack Holder, Mic Jack P.C.B., Speaker	(Fig. D14)	Screw (N) × 1
			FP9302 (Flex)
			Convex × 1
			Mic Jack Holder
			Mic Jack P.C.B.
			Solder (2 points)
			Speaker
6	Side Operation Unit Front Case Unit	(Fig. D15)	Screw (O) × 2
			Locking tab × 2
			Side Frame
			Screw (P) × 2
			Lens Ring
			Convex × 4
			Side Operation Unit
			Front Case Unit
7	Battery Door Unit	(Fig. D16)	Screw (Q) × 2
			Battery Door Unit
8	Flash P.C.B. Unit	(Fig. D17)	Convex × 1
			Locking tab × 1
		(Fig. D18)	Screw (R) × 1
			Locking tab (A) × 3
			Condenser Cover
			Locking tab (B) × 2
		(Fig. D19)	Solder (4 points)
			Flash P.C.B. Unit
9	LVF Module	(Fig. D20)	Convex (A) × 2
			Hooking part (A) × 2
			Multi FPC Unit
			Screw (S) × 2
			Convex (B) × 2

			Locking tab × 2
			Hooking part (B) × 2
			LVF Cover Unit
			LVF Unit
			Heat Radiation Pad
			LVF Module
10	Flash Tray Unit, Shoe Spring, Flash Case Top	(Fig. D21)	Screw (T) × 3
			Flash Tray Unit
			Shoe Spring
			Screw (U) × 2
			Locking tab × 2
			Flash Case Top
11	Rear Operation Unit Hinge SW FPC	(Fig. D22)	Screw (V) × 2
			Locking tab × 1
			Hinge Arm Cover
			Screw (W) × 12
			Convex (A) × 6
			Rear Plate Unit
			Convex (B) × 5
			Rear Operation Unit
			Solder (6 points)
			Convex (C) × 8
			Hinge SW FPC
12	LCD Hinge Unit (with LCD Unit)	(Fig. D23)	Convex × 4
			Screw (X) × 2
			Hinge Earth
			Spacer
			Hinge Fix Cover
			Hinge Cushion 4
			LCD Hinge Unit (with LCD Unit)
13	LCD IF P.C.B., MR Sensor FPC, LCD Unit	(Fig. D24)	Screw (Y) × 2
			Screw (Z) × 2
			Locking tab × 8
			LCD Case Bottom
		(Fig. D25)	FP4101 (Flex)
			FP4102 (Flex)
			FP4103 (Flex)
			FP4104 (Flex)
			Locking tab × 1
			LCD IF P.C.B.
		(Fig. D26)	Convex × 2
			MR Sensor FPC
		(Fig. D27)	LCD Bezel Sheet
			LCD Bezel
			LCD Earth Plate × 2
			LCD Unit
		(Fig. D28)	When Installing

### 9.3.1 Removal of the Rear Case Unit

**NOTE:**

- When servicing and reassembling, remove the memory card and battery from the unit.  
Install the lens cap to prevent garbage and dust except when it is necessary.

- Memory Card
- Battery
- Screw (A) × 3
- Screw (B) × 3
- Screw (C) × 2

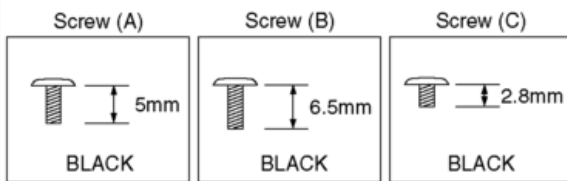
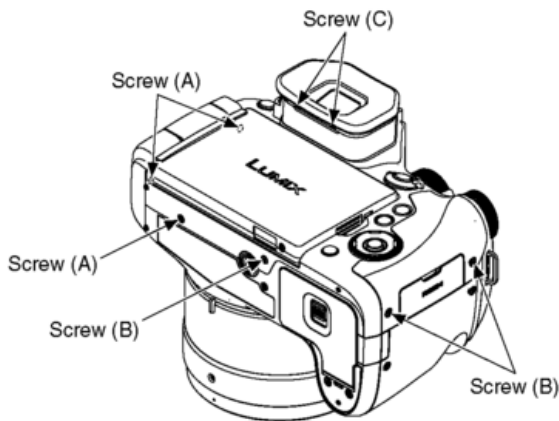
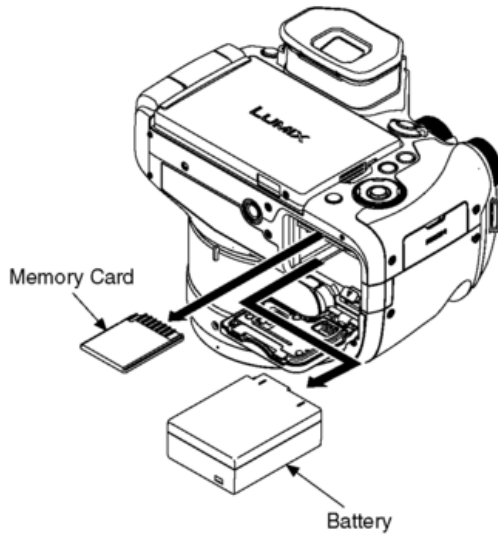

(Fig. D1)

(Fig. D2)



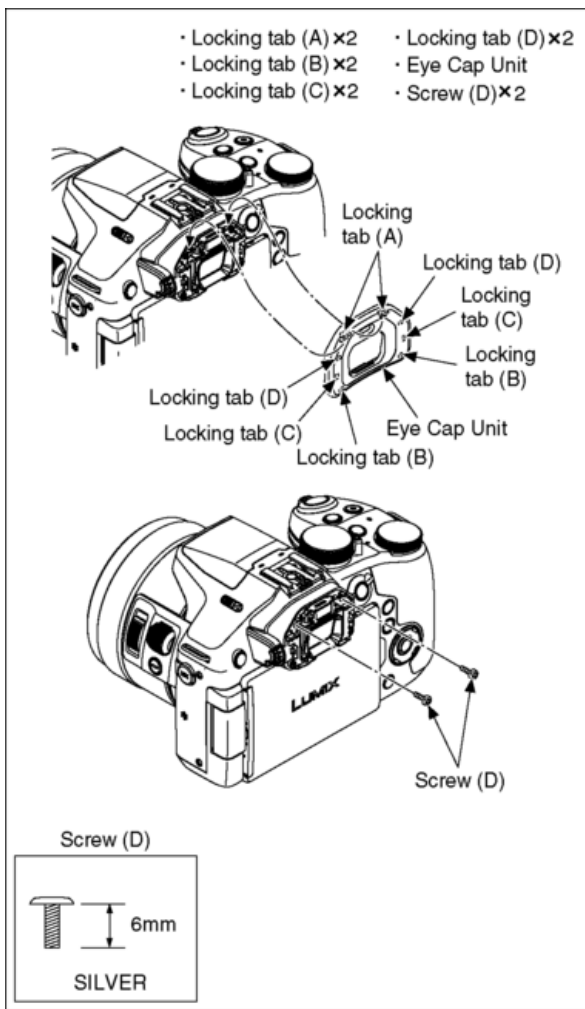

(Fig. D3)

**NOTE: (When Installing)**

• According to the following procedure, attach the Eye Cap Unit so as not to form any clearance among Eye Cap Unit, Rear Case Unit and Top Case Unit.

1. Push in the Eye Cap Unit in the arrow direction (1), and hook the Locking tab (1) on the Hooking part.
2. Push in the Eye Cap Unit in the arrow direction (2), and hook the Locking tab (2) on the Hooking part.
3. Push in the Eye Cap Unit in the arrow direction (3), and hook the Locking tab (3) on the Hooking part.
4. Release your finger once. Then, push in the Eye Cap Unit in the arrow direction (4), and hook the Locking tab (4) on the Hooking part.

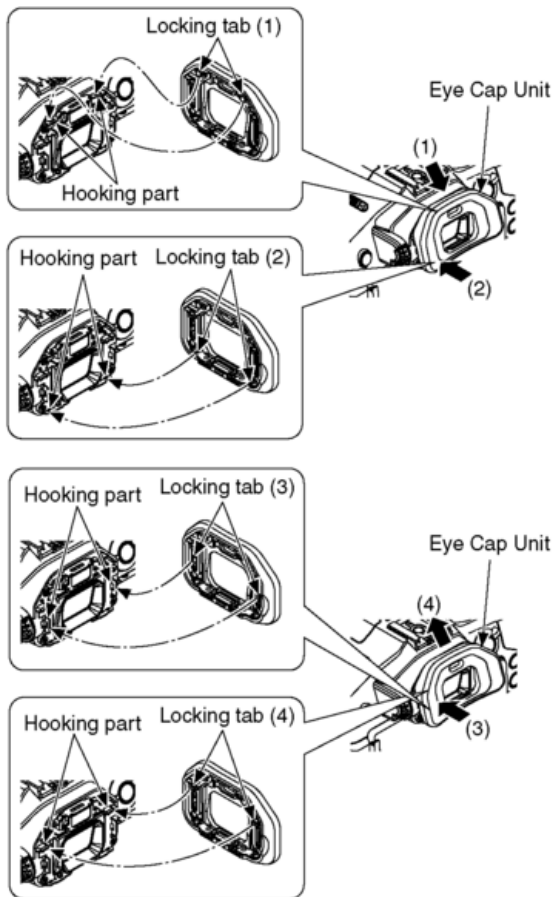

※ Make sure there is no clearance.

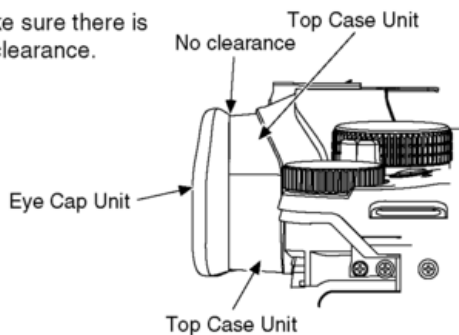

(Fig. D4)

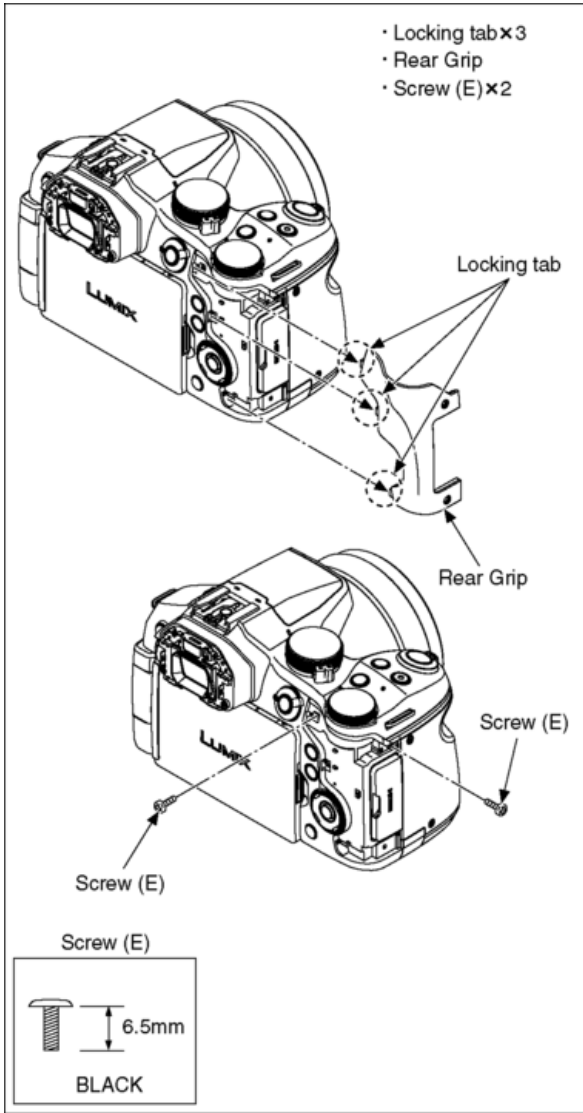

D4)

9.3.2 Removal of the Main P.C.B.

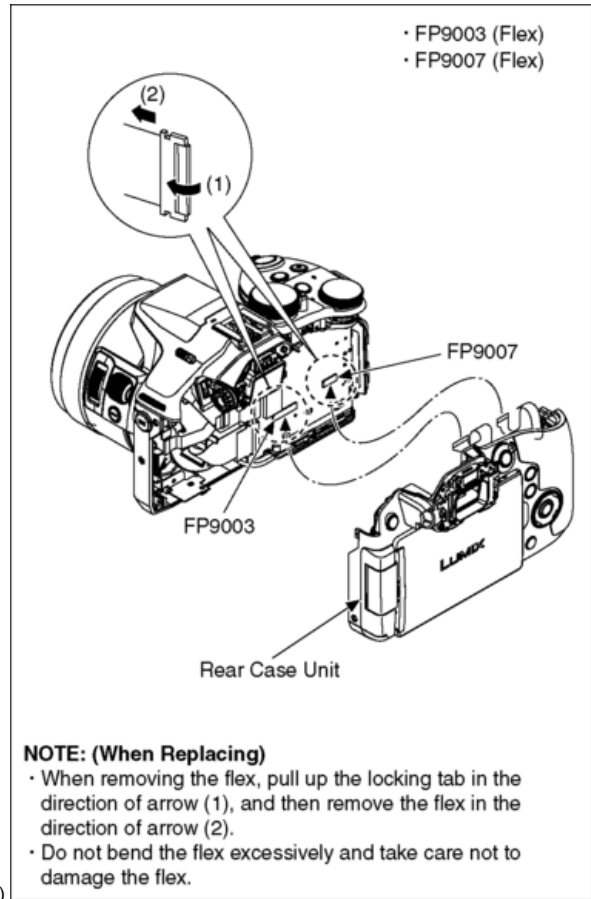

(Fig. D5)

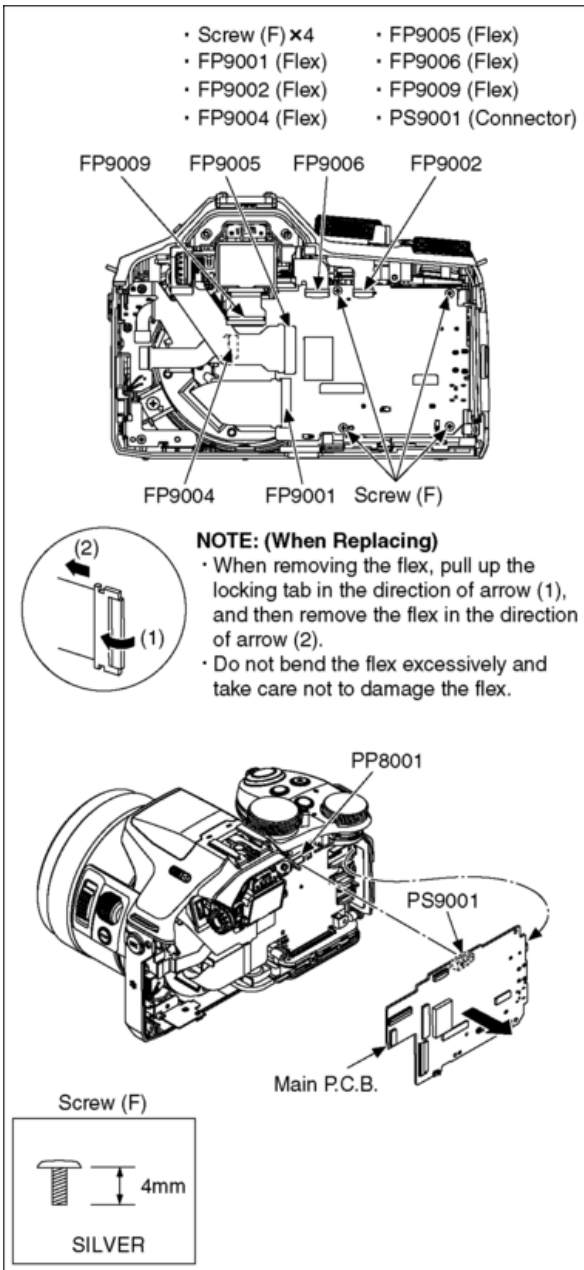

(Fig. D6)

(Fig. D7)

**NOTE: (When Replacing)**

- Paste the Thermal Sheet A and Thermal Sheet B to the foil and component side.
- When pasting the Thermal Sheet A and Thermal Sheet B, should not press hard. (Cause damage.)
- When pasting the Thermal Sheet A and Thermal Sheet B, make sure the paste standard.

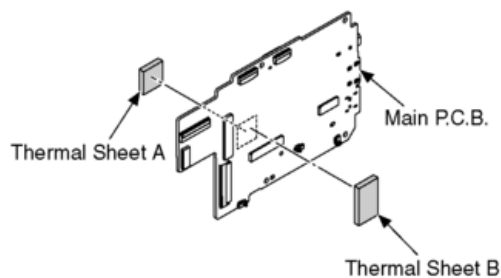
**Paste standard (Thermal Sheet A/B)**

(Foil Side)

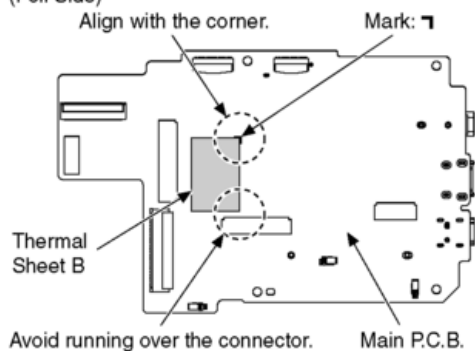

(Component Side)

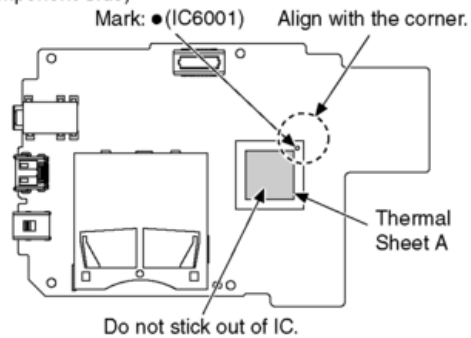
**9.3.3 Removal of the Top Case Unit and Battery Case Unit**

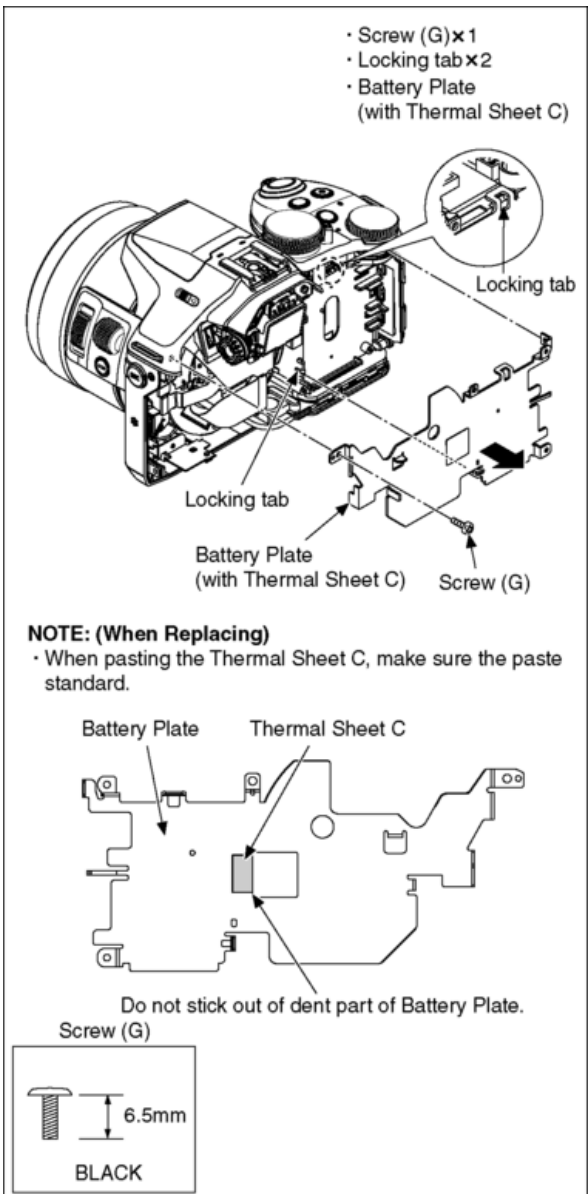

(Fig. D8)

(Fig. D9)

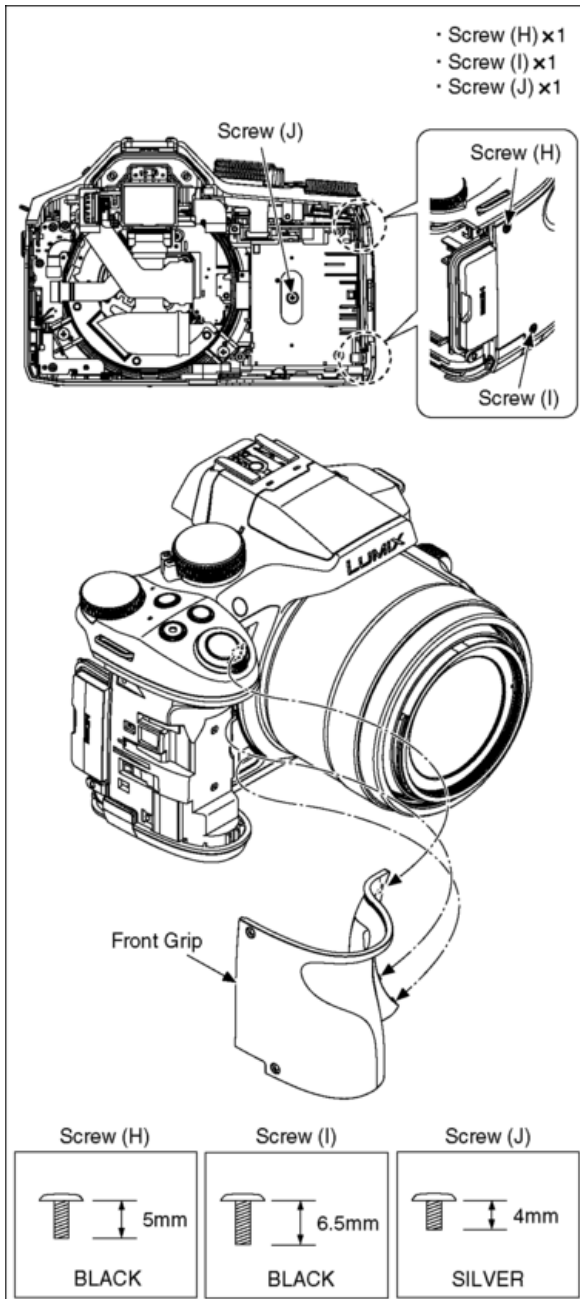

(Fig. D10)

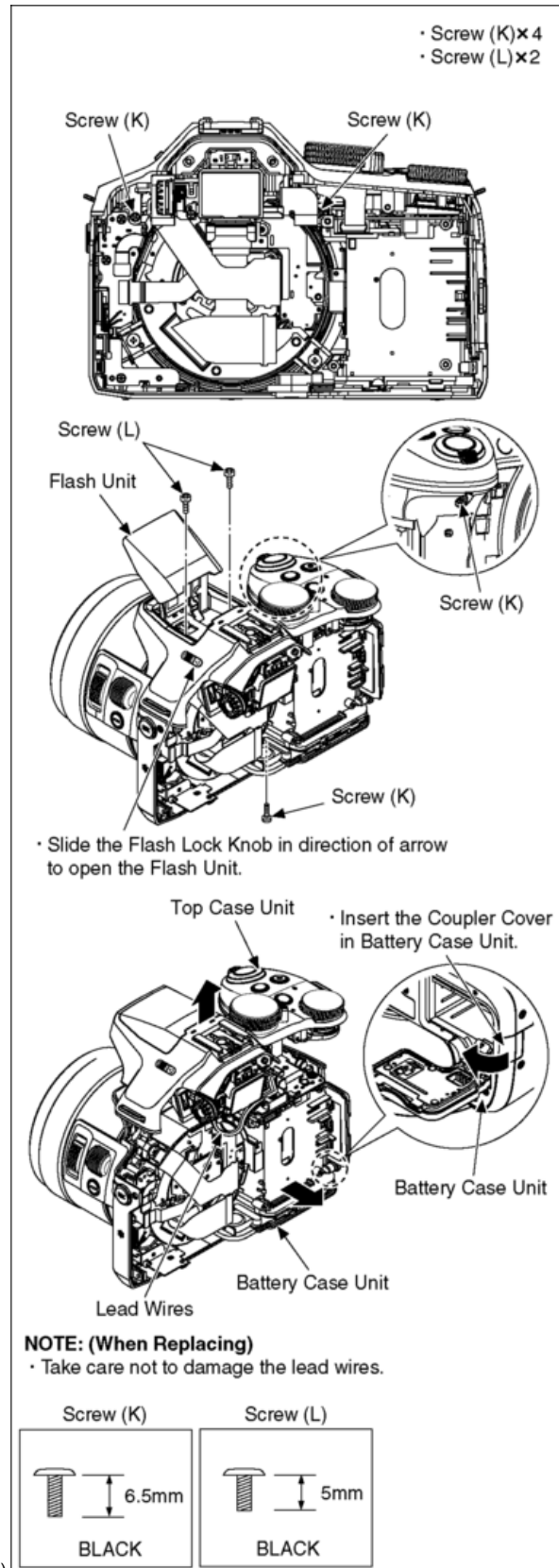

(Fig.)

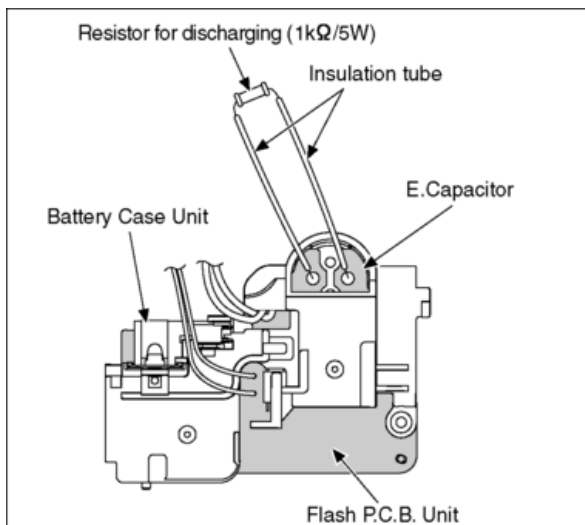

### ⚠ CAUTION

Be sure to discharge the E.Capacitor on Flash P.C.B. Unit before disassembling.

Be careful of the high voltage circuit on Flash P.C.B. Unit when servicing.

1. Put the insulation tube on the lead part of resistor (ERG5SJ102:1kΩ /5W).  
(An equivalent type of resistor may be used.)
2. Put the resistor between both terminals of E.Capacitor on the Flash P.C.B. Unit for approx.
3. After discharging, confirm that the E.Capacitor voltage is lower than 10V by using a voltmeter.

### NOTE: (When Installing)

- Arrange the lead wires under the hooking part.

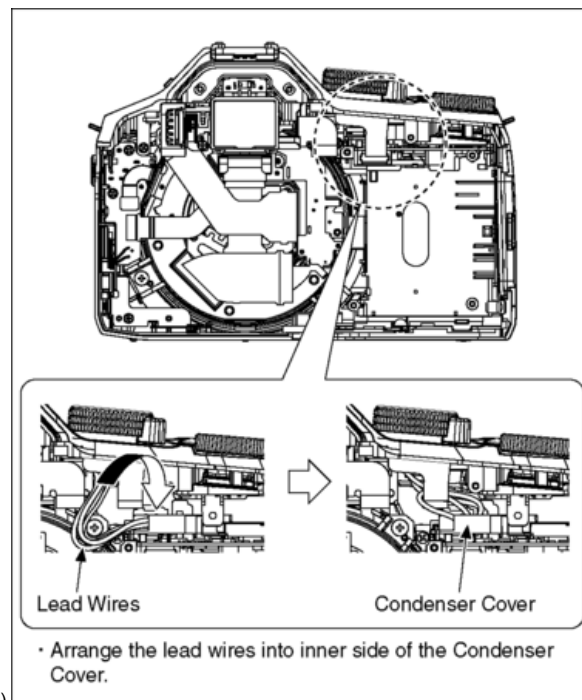
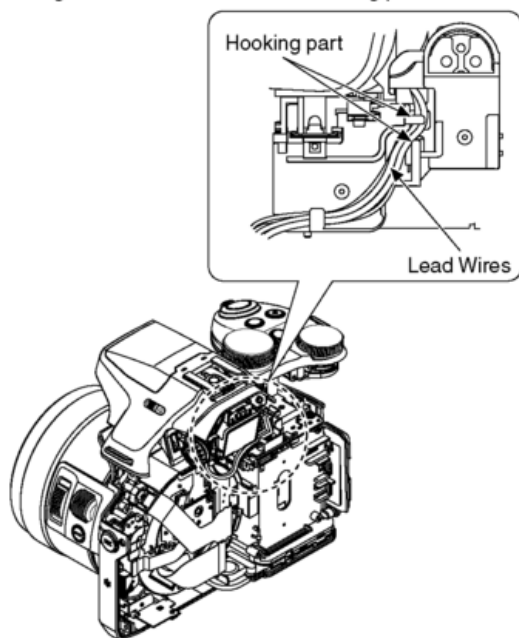

D11)

(Fig. D12)

### 9.3.4 Removal of the Lens Unit

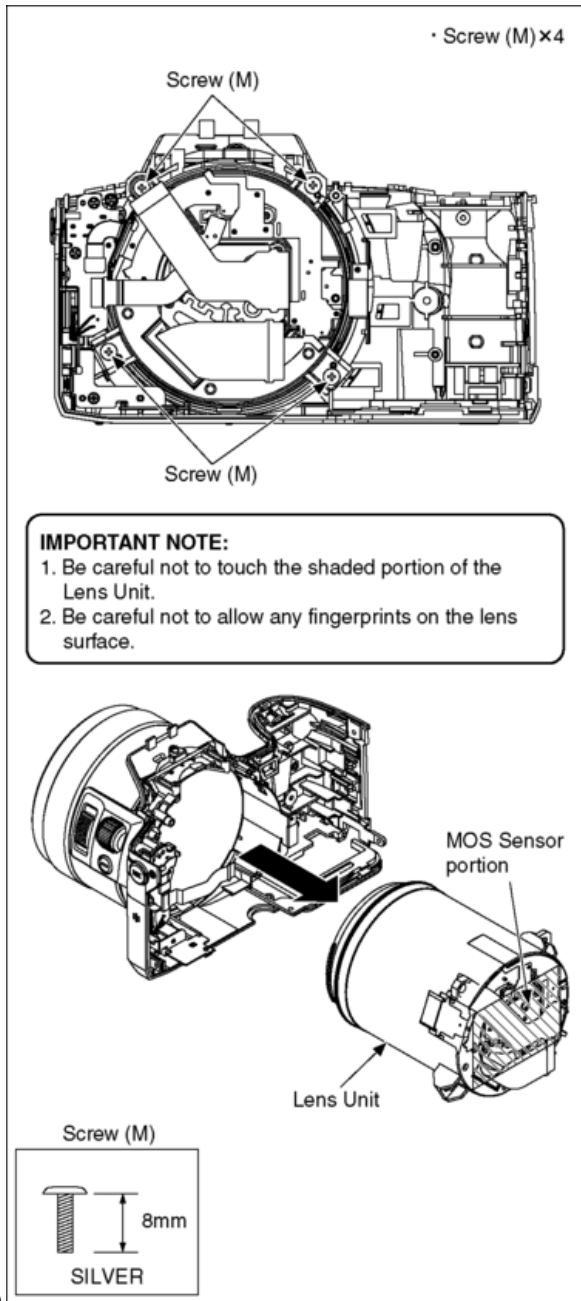

(Fig. D13)

### 9.3.5 Removal of the Mic Jack Holder, Mic Jack P.C.B. and Speaker



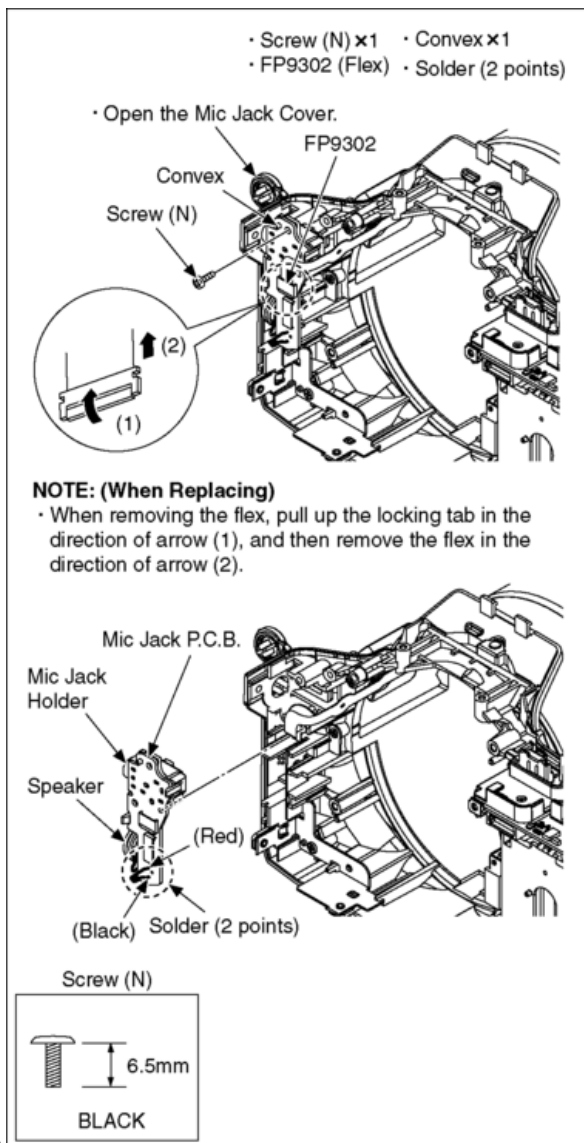

(Fig. D14)

### 9.3.6 Removal of the Side Operation Unit and Front Case Unit

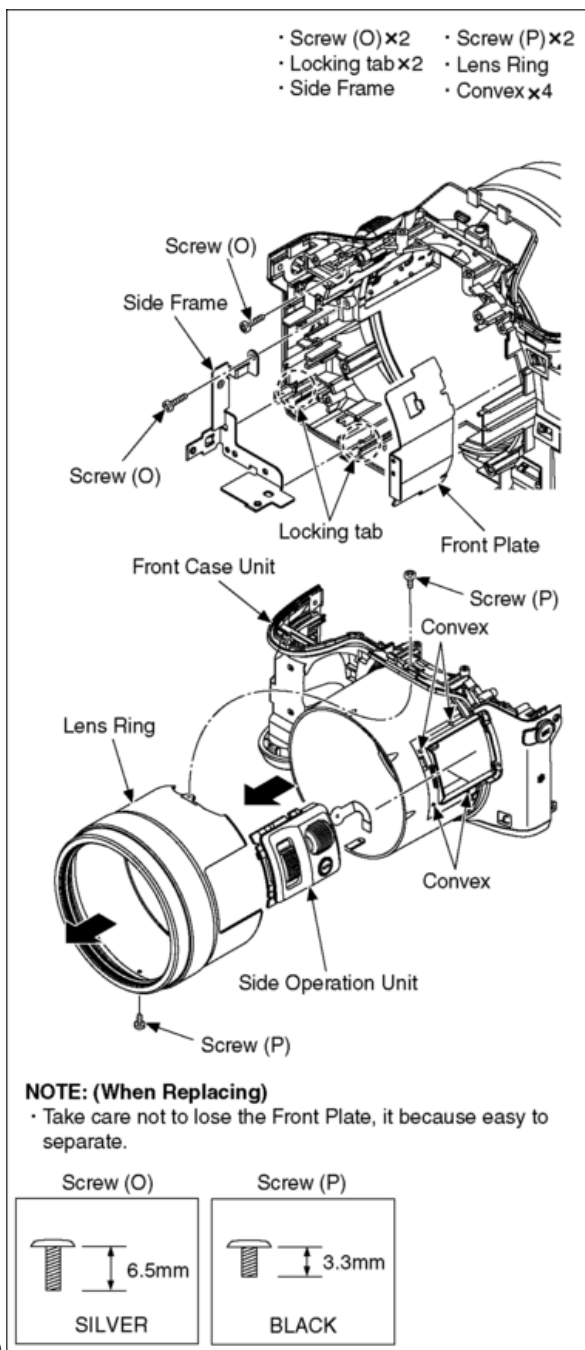

(Fig. D15)

### 9.3.7 Removal of the Battery Door Unit

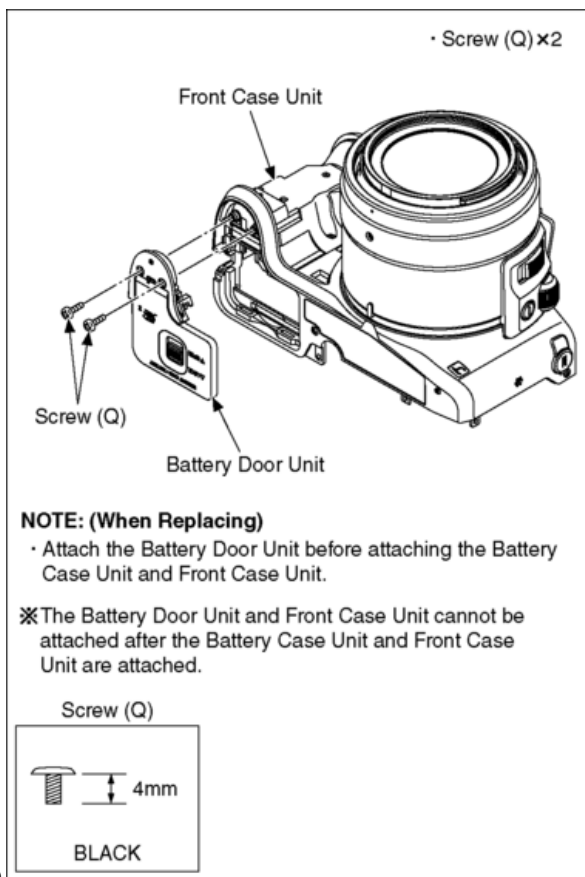

(Fig. D16)

### 9.3.8 Removal of the Flash P.C.B. Unit

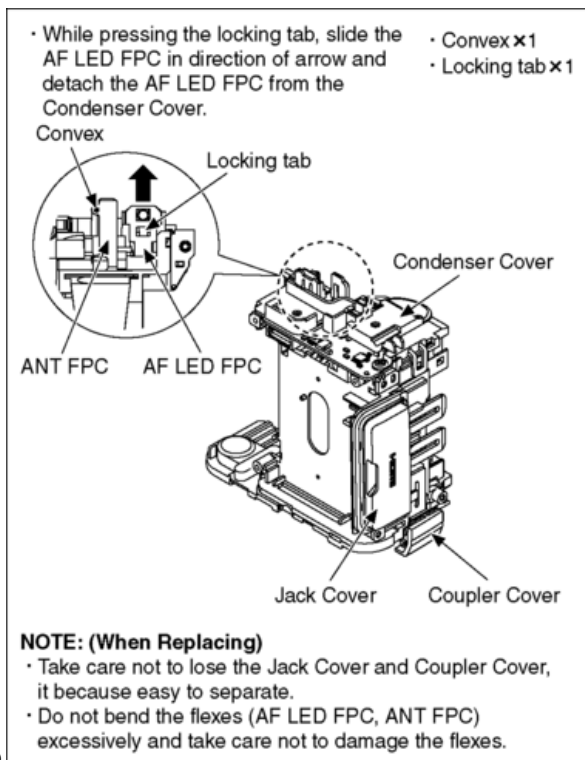

(Fig. D17)

(Fig. D18)

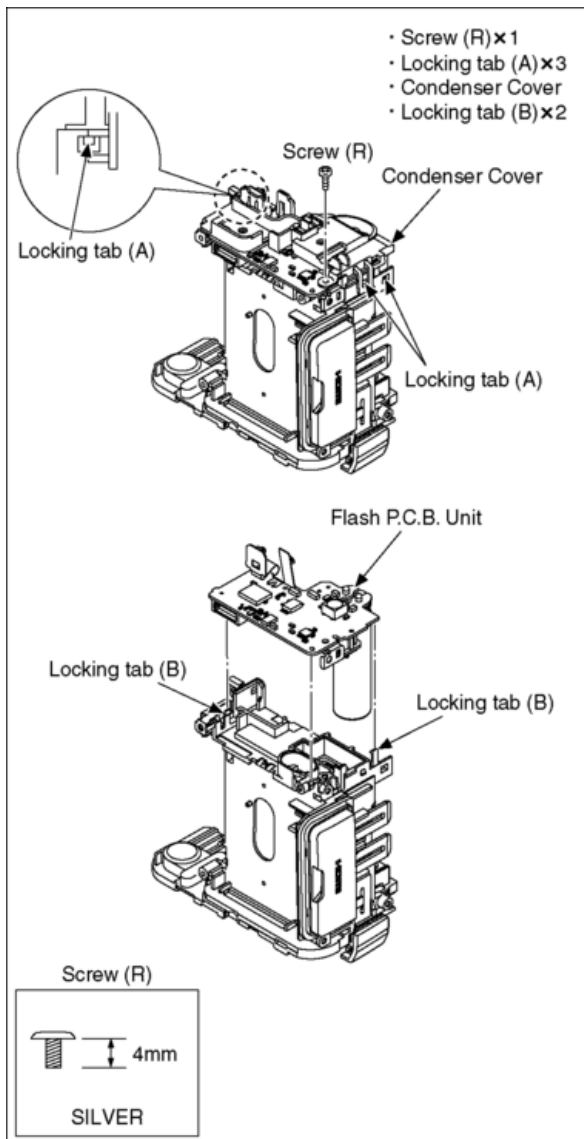

(Fig. D19)

### 9.3.9 Removal of the LVF Module

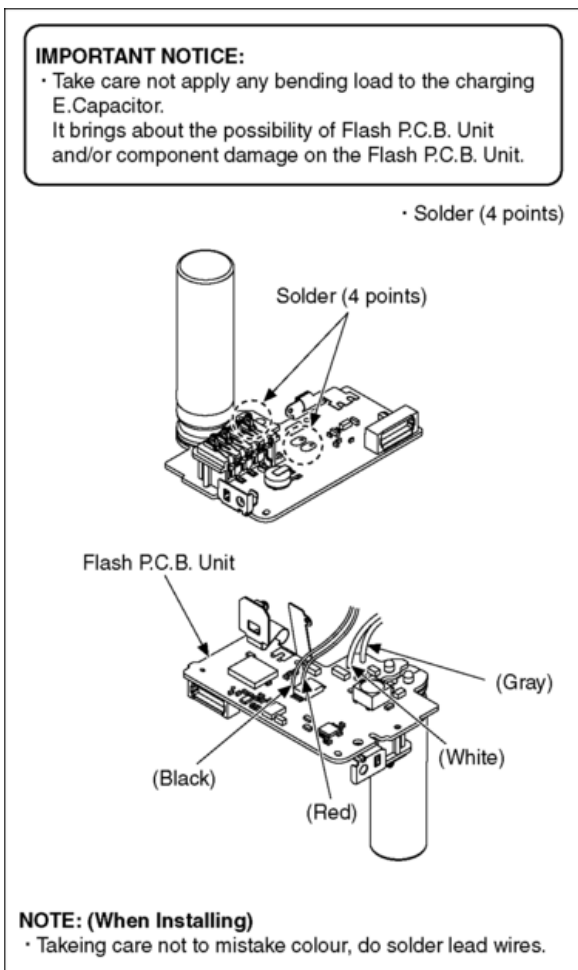

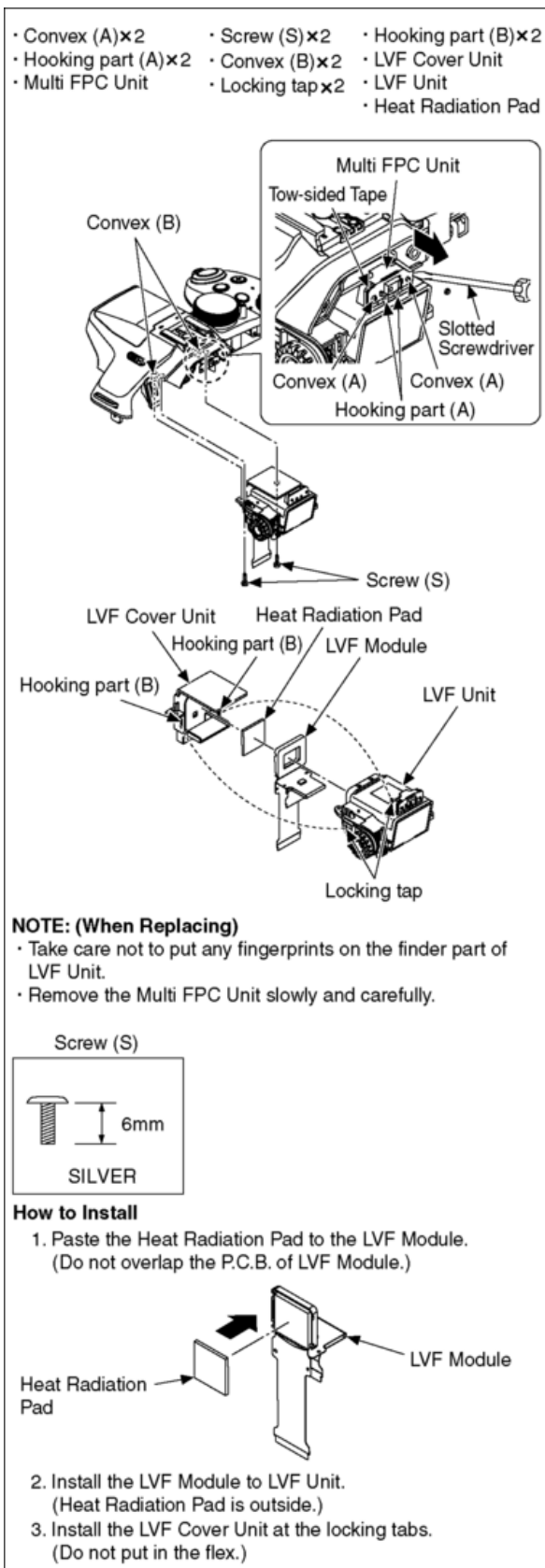

(Fig. D20)

### 9.3.10 Removal of the Flash Tray Unit, Shoe Spring and Flash Case Top

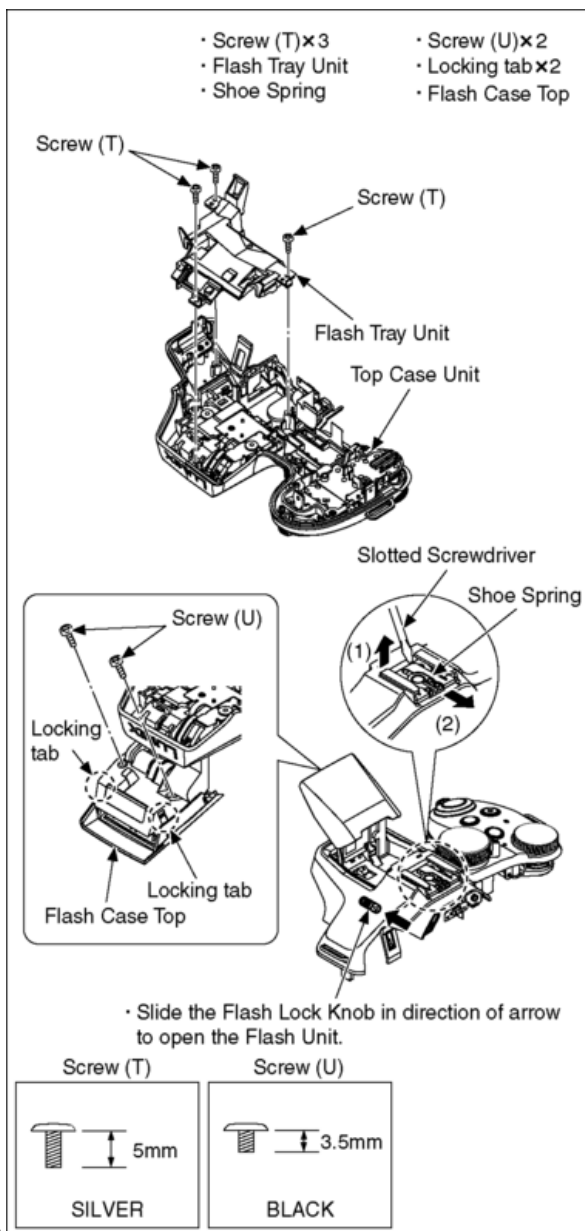

(Fig. D21)

9.3.11 Removal of the Rear Operation Unit and Hinge SW FPC

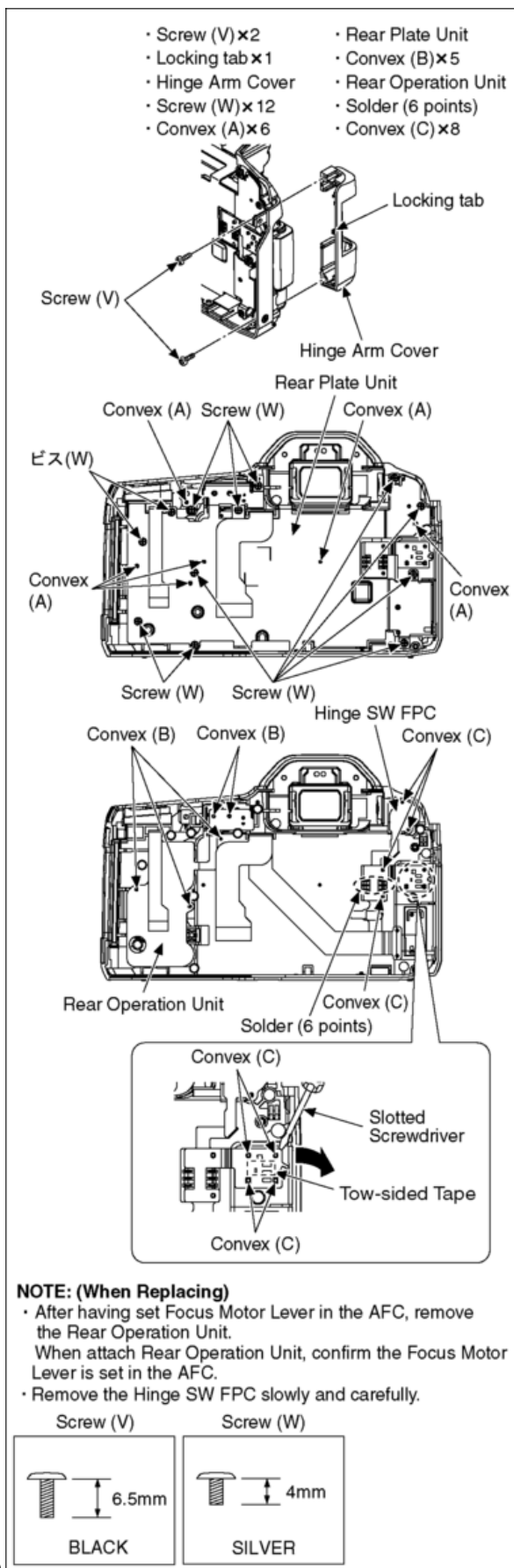

(Fig. D22)

9.3.12 LCD Hinge Unit (with LCD Unit)

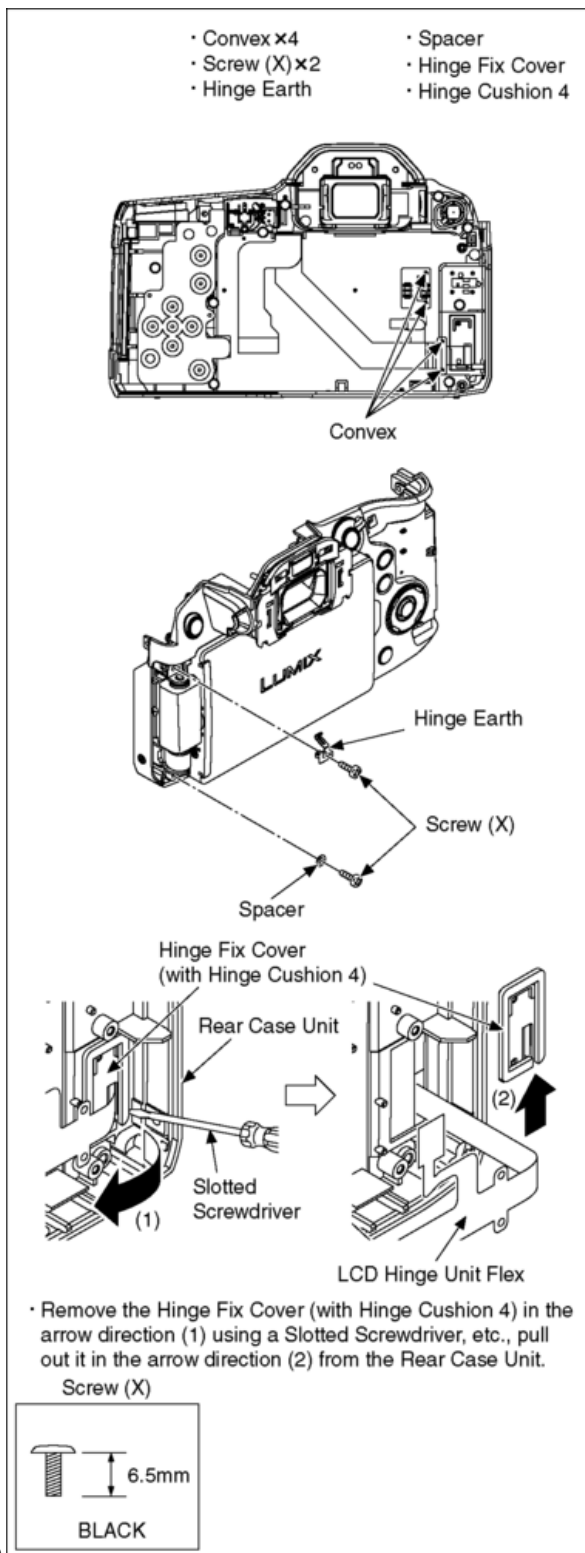

(Fig. D23)

9.3.13 Removal of the LCD IF P.C.B., MR Sensor FPC and LCD Unit



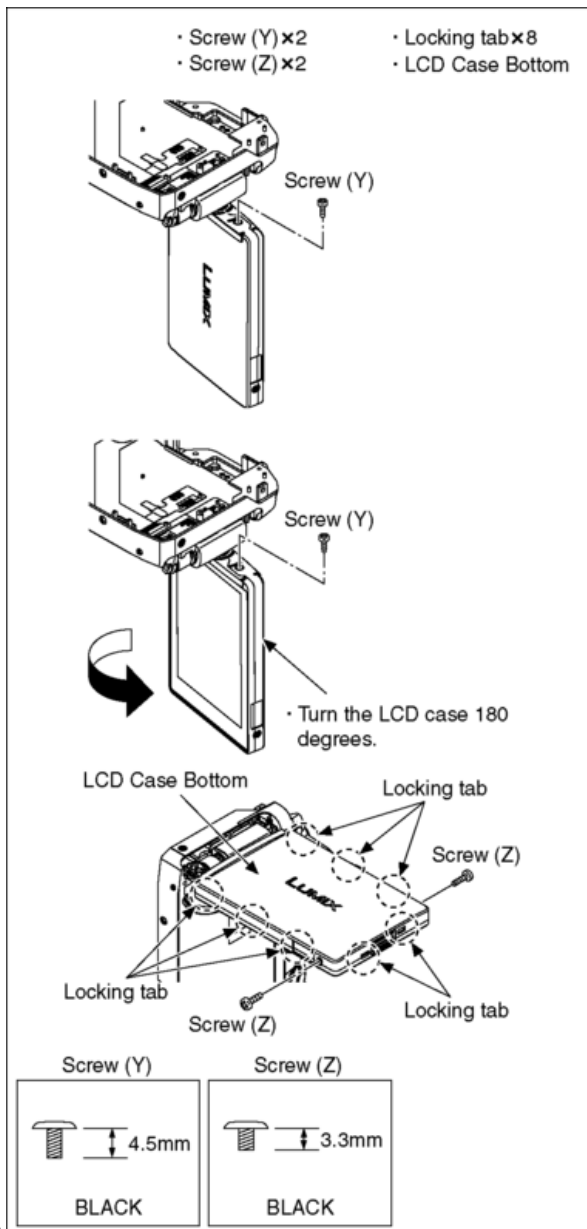

(Fig. D24)

(Fig. D25)

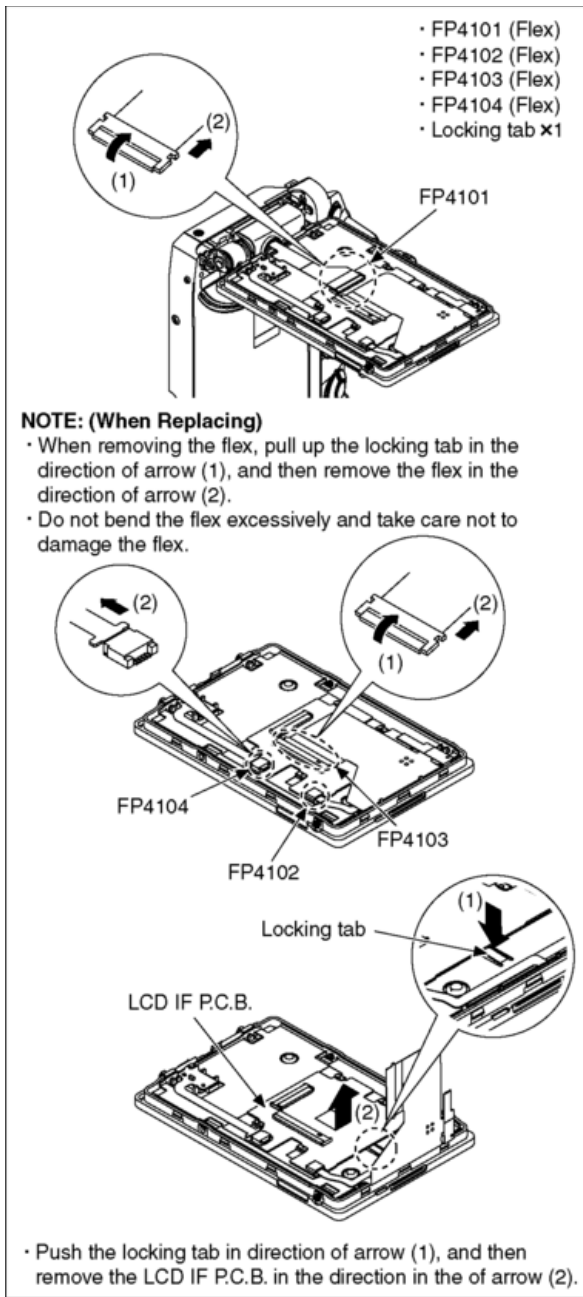

(Fig. D26)

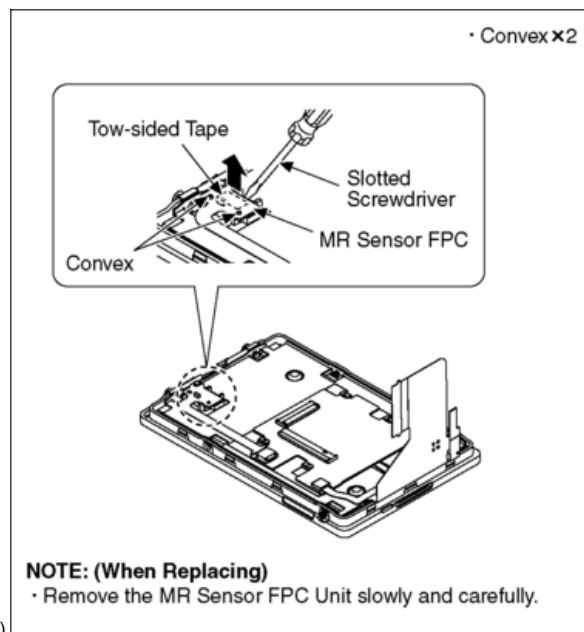

(Fig.

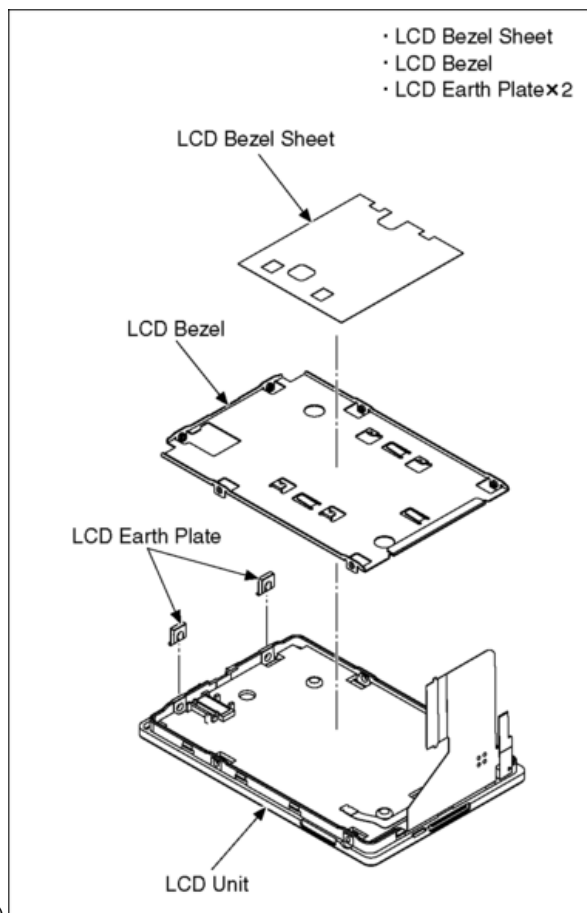

D27)

(Fig. D28)

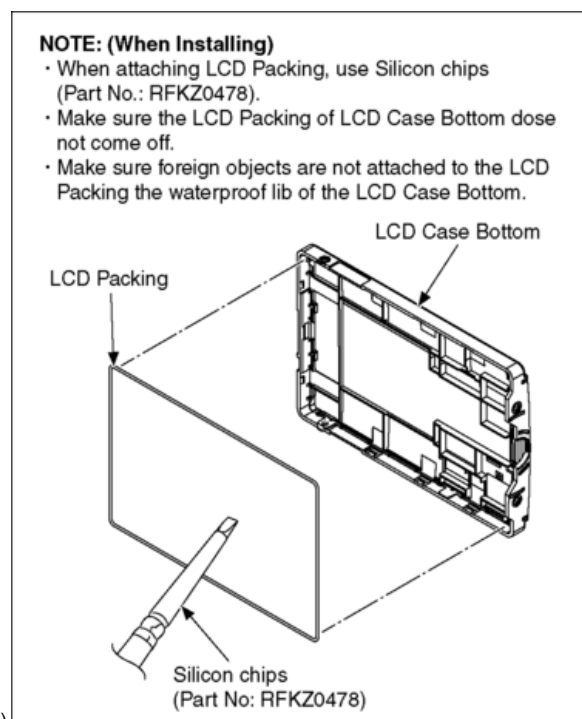
**NOTE: (When Installing)**

Make sure to confirm the following points when installing:

- The screw is tightened enough.
- Installing conditions are fine. (No distortion, no abnormal-space.)
- No dust and/or dirt on lens surfaces.
- LCD image is fine. (No dust and/or dirt on it, and no gradient images.)

## 9.4 Lens Disassembly Procedure

### Precaution:

1. Do not remove the MOS unit when disassembling or re-assembling the lens in order to maintain it clean.  
The screws for fixing the MOS unit to the master flange unit are locked by glue with the adjustment of the installation angle of the MOS unit to the lens (optical axis adjustment) finished.  
When remove it, refer to item "9.5."
2. Keep dust or dirt away from the lens.  
To remove dirt or dust from the lens, blow with dry air.
3. Do not touch the lens surface.
4. Use lens cleaning KIT (VFK1900BK).
5. Apply grease as shown on item "9.4.8." and "9.4.9." in the figure.

### 9.4.1 Removal of the Lens Flex Unit

1. Unscrew the 2 screws (A).
2. Remove the 10 Ribs.

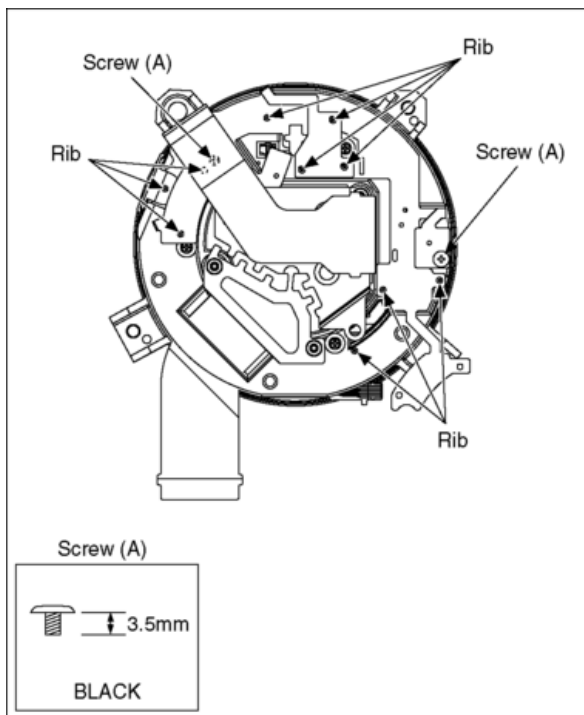

3. Remove the 3 connector.
4. Remove the lens flex unit.

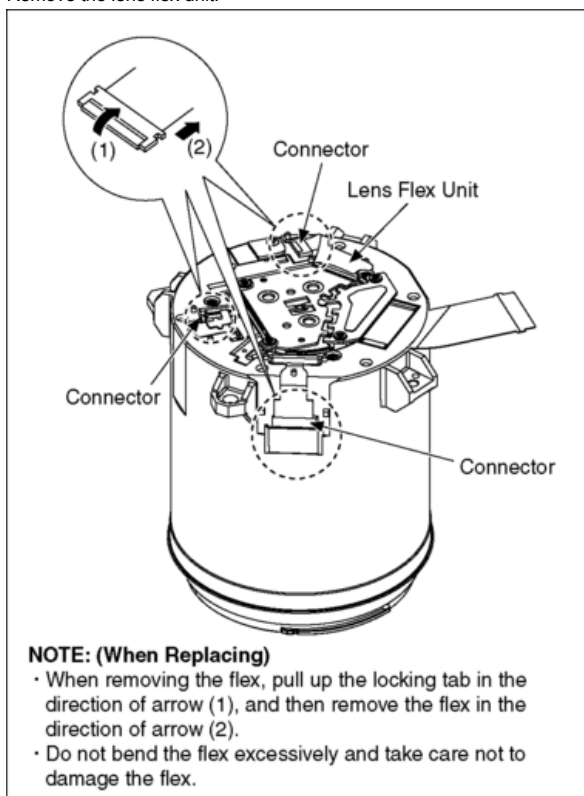

#### 9.4.2 Removal of the Master Flange Unit

1. Unscrew the 3 screws (B).
2. Remove the master flange unit.

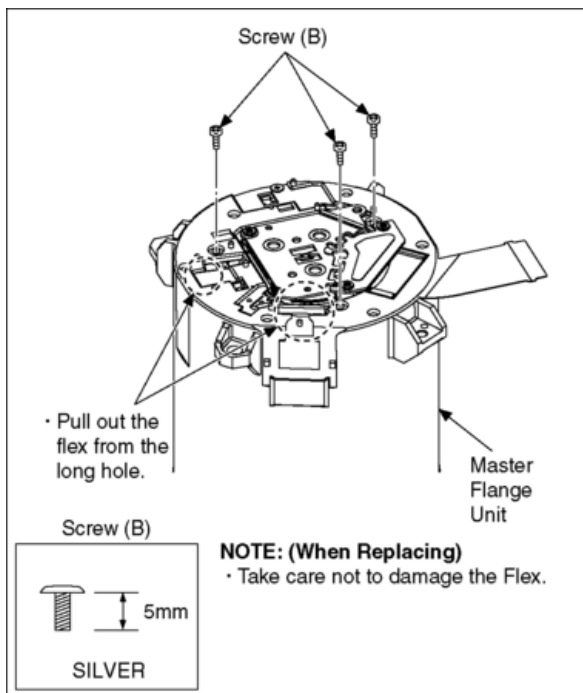

#### How to Install

1. Insert the connector joint of shutter in slit part of Middle Frame Unit.
2. Pass the Shutter Flex and Focus Motor Flex through the long hole of Master Flange Unit.
3. Fasten the 3 screws (B).

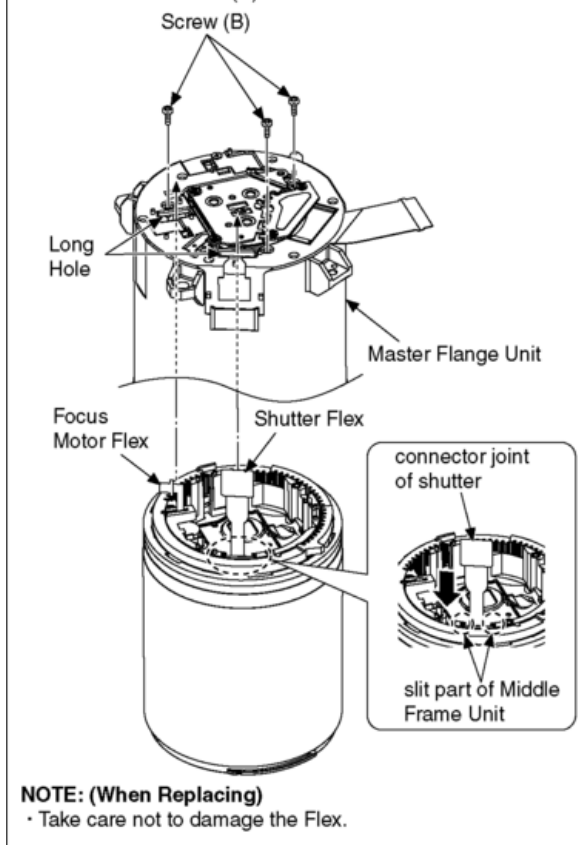

#### 9.4.3 Removal of the Zoom Motor

1. Unscrew the 2 screws (C).

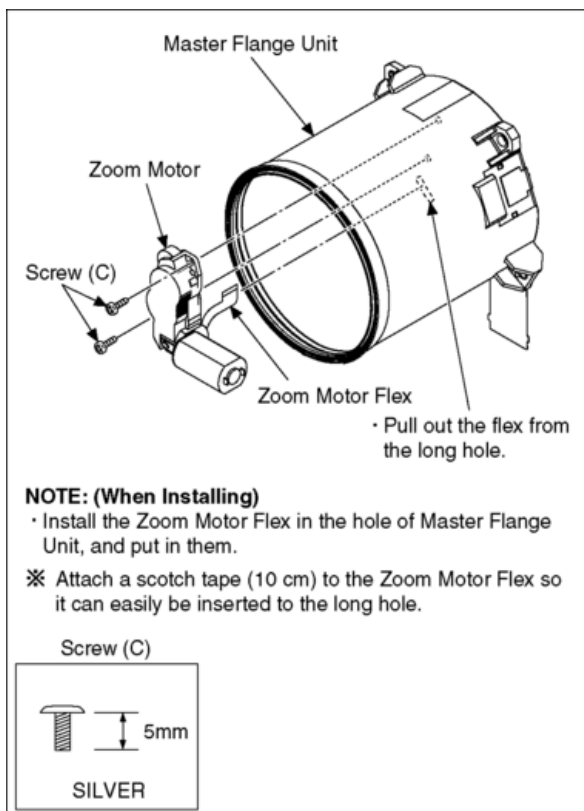

#### 9.4.4 Removal of the 1st Lens Frame Unit

1. Turn the cam frame in the direction of arrow fully, and remove the 1st lens frame unit.

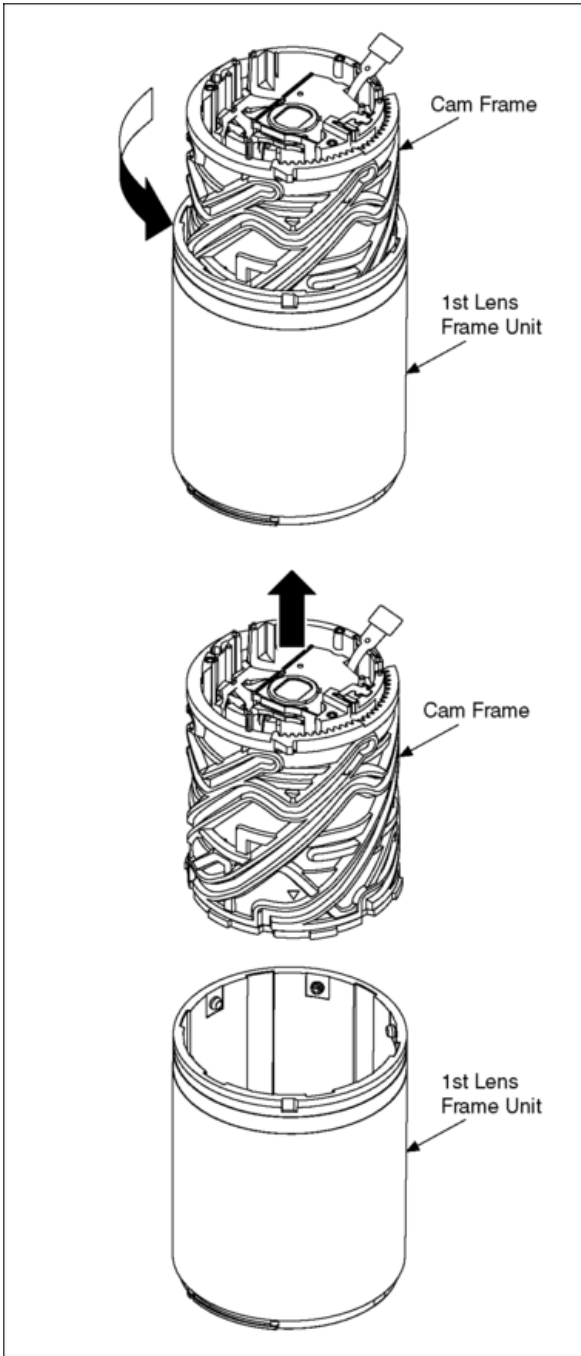

**How to Install**

1. Align the groove of cam frame and the groove of middle frame unit.

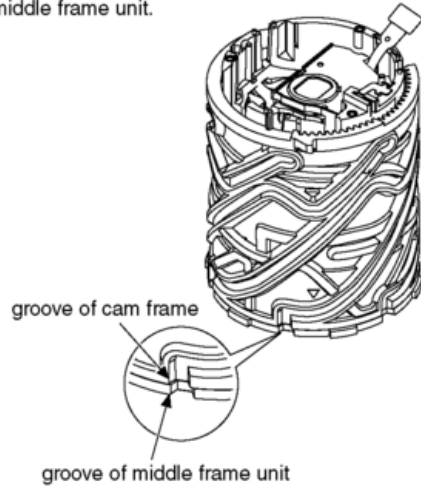

2. Align the  $\Delta$  mark of cam frame and concave of 1st lens frame unit, and then install them.

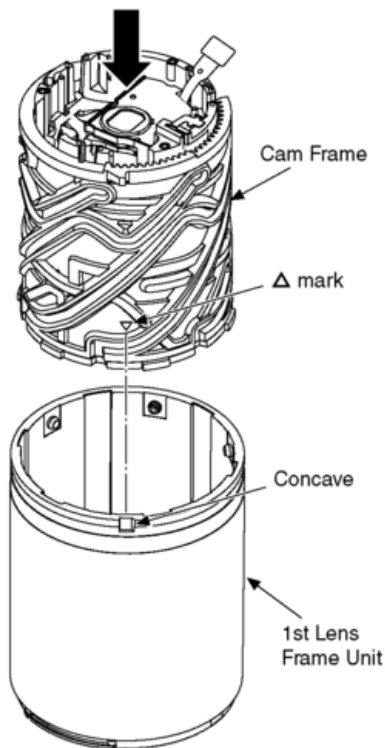
**NOTE: (When Installing)**

- Take care not to put fingerprint of the lens.



3. Install the cam frame. And turn the cam frame in the direction of arrow a little.

Rotation angle: 2 gear  $\pm$  1 gear

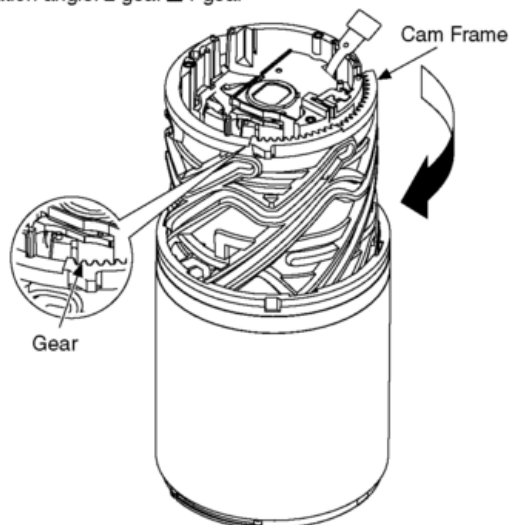

4. Insert the shutter flex to slit of middle frame unit.

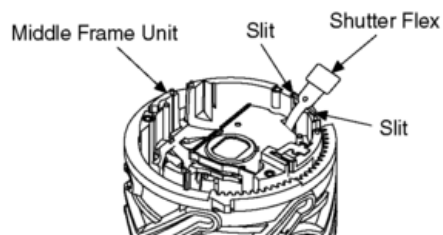

**NOTE: (When Replacing)**

- Take care not to damage the Flex.
- Take care not to put fingerprint of the lens.

#### 9.4.5 Removal of the 5th Lens Frame Unit

1. Remove the 5th lens frame unit in the direction of arrow.

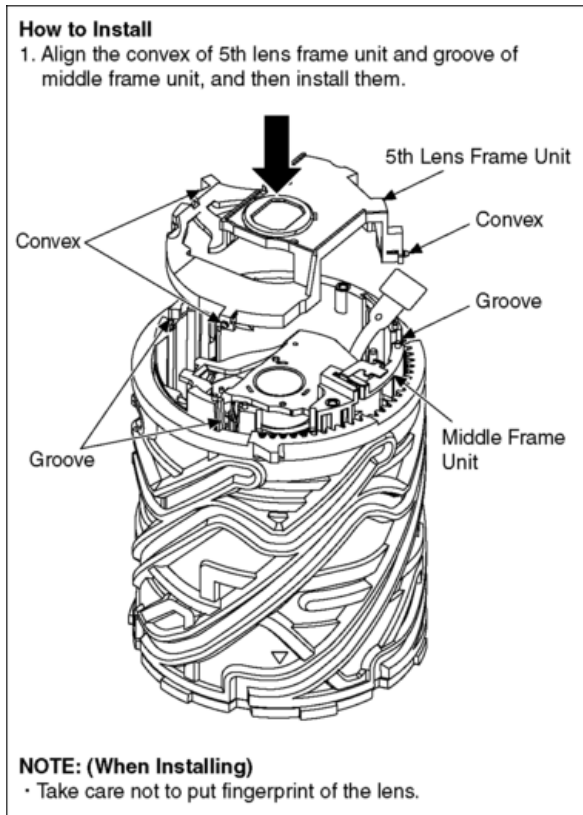
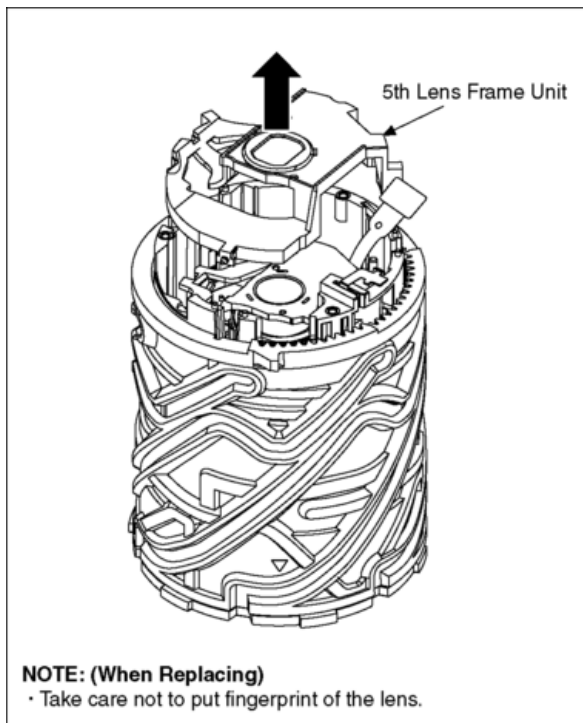

#### 9.4.6 Removal of the 2nd Lens Frame Unit

- Hold the middle frame unit, and turn the cam frame unit in the direction of arrow (1) fully.(about half turn)
- Reverse the cam frame, and remove the 2nd lens frame unit. (Catch the 2nd lens frame unit.)

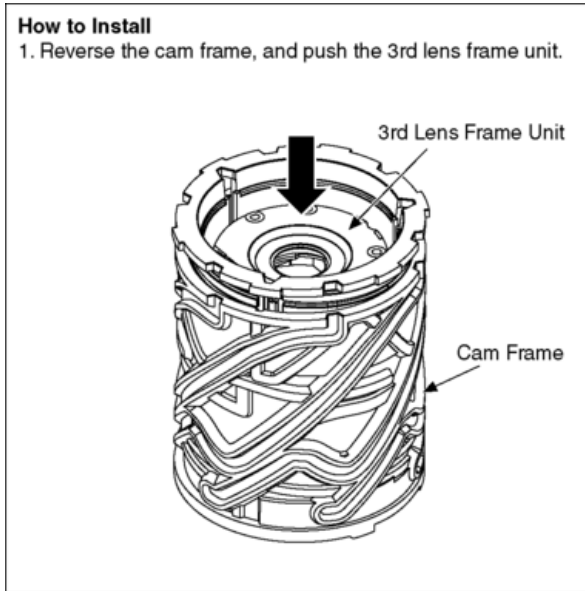
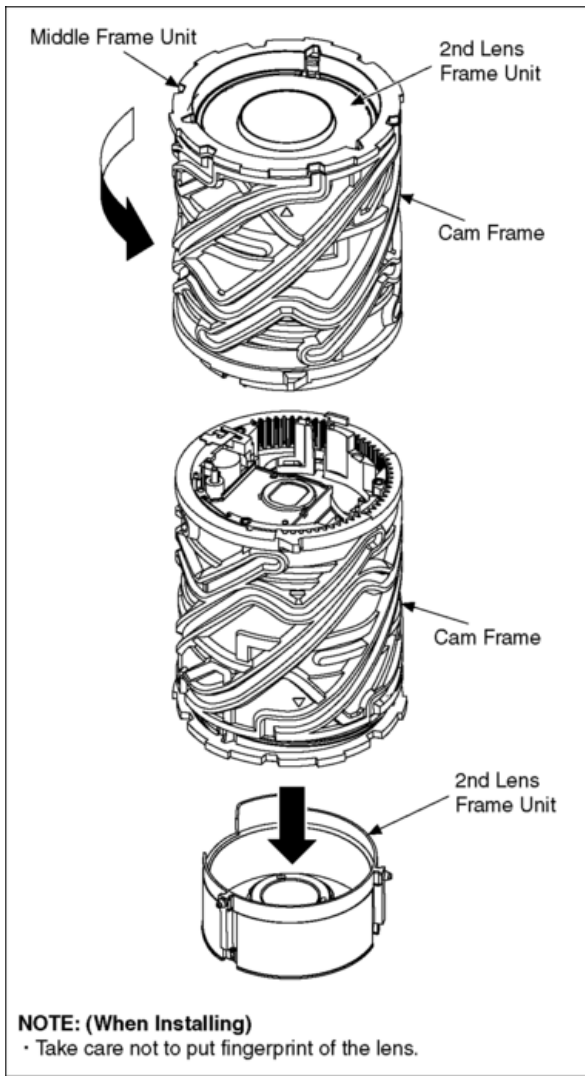

2. Turn the cam frame unit in the direction of arrow fully.

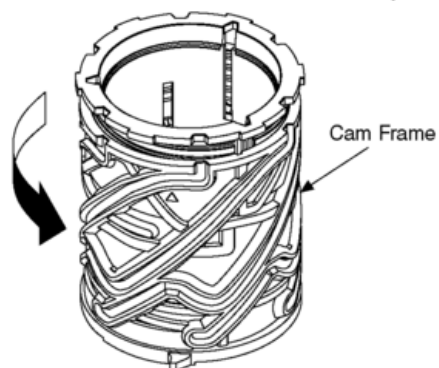

3. Align the convex (3 points) of 2nd lens frame unit and groove of middle frame unit, and then install them.  
(Align the concave of 2nd lens frame unit and focus motor unit.)

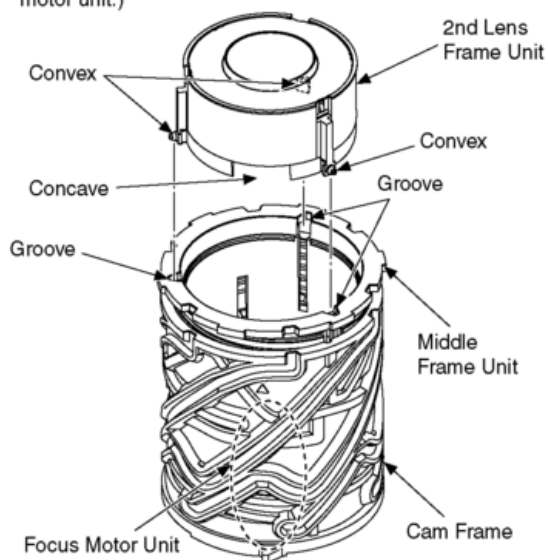

**NOTE: (When Installing)**

· Take care not to put fingerprint of the lens.

4. Turn the cam frame the direction of arrow fully.

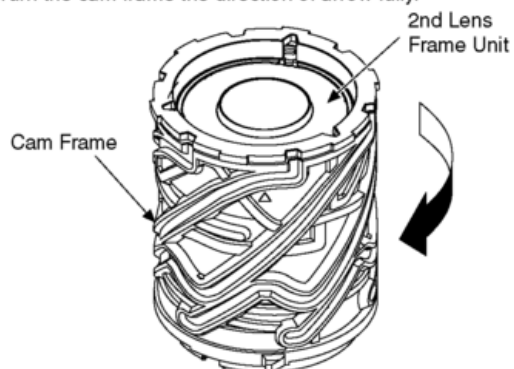

#### 9.4.7 Removal of the Cam Frame Unit

1. Turn the cam frame unit in the direction of arrow (1) fully.(about half turn)
2. Move the 3rd lens frame unit to bottom. And turn the cam frame unit in the direction of arrow (2) fully, and remove the cam frame unit.

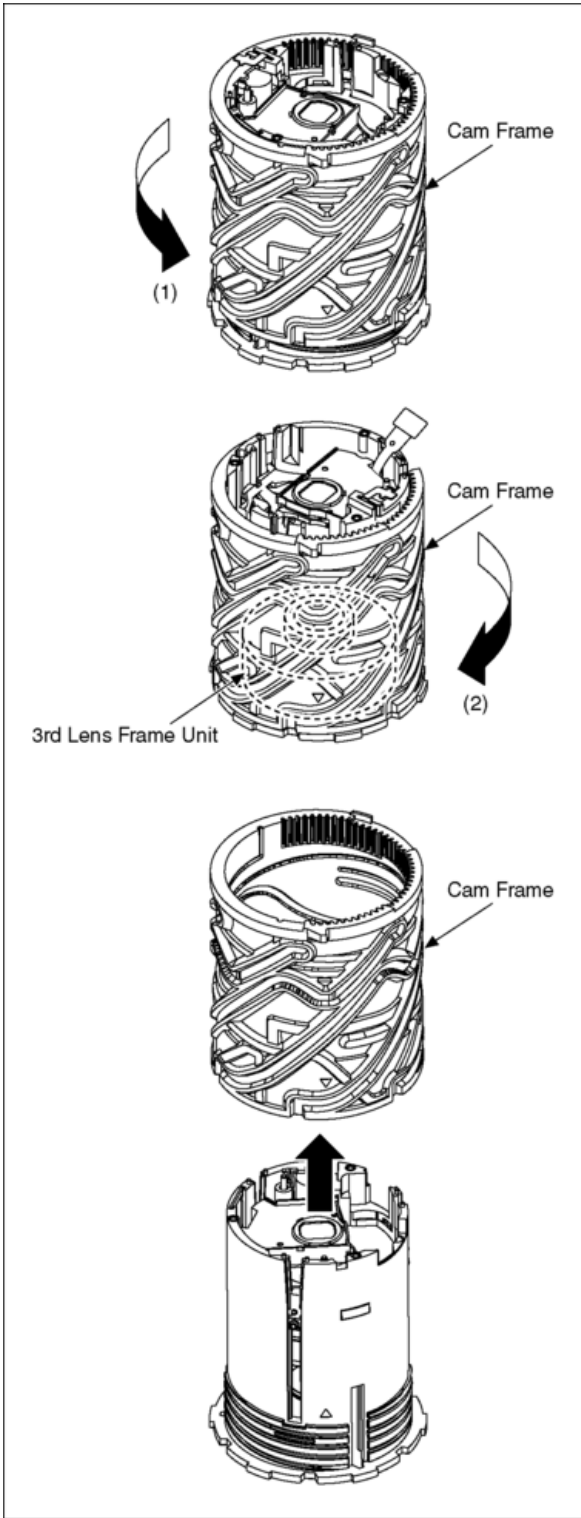

**How to Install**

1. Align the  $\Delta$  mark of middle frame unit and  $\Delta$  mark of cam frame, and then install them.

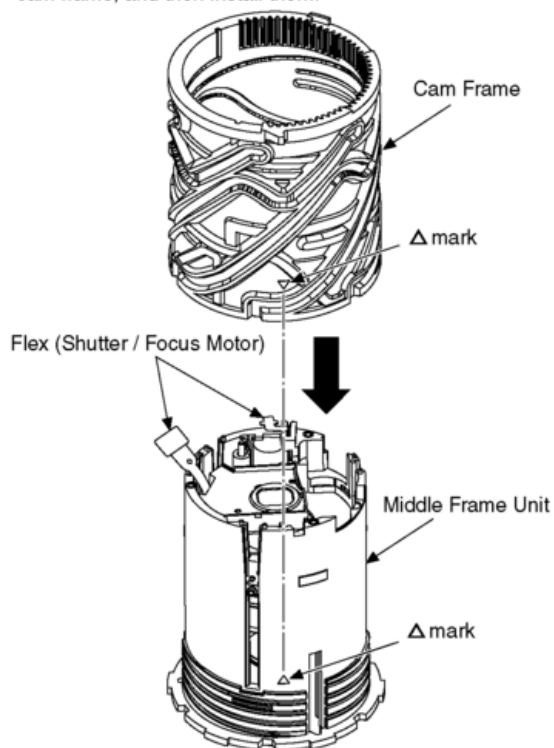
**NOTE: (When Replacing)**

- Take care not to damage the Flex.

2. Turn the cam frame the direction of arrow fully.

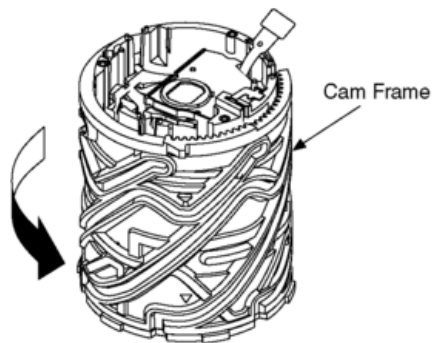
**9.4.8 Removal of the Focus Motor Unit**

1. Unscrew the 2 screws (D).
2. Remove the focus motor unit.  
(Also remove the flex from groove.)

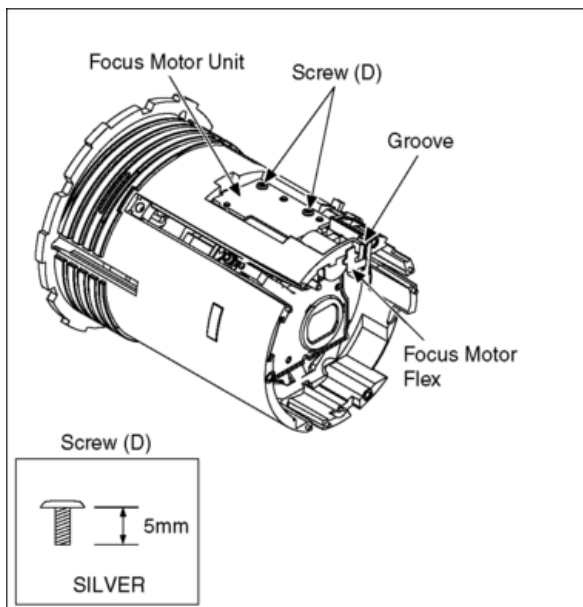

### How to Install

1. Blow air to the screw shaft of focus motor unit to prevent the adhesion of foreign material.
2. Apply grease to the screw shaft of focus motor unit.

#### ■ Grease Application Area

Grease: RFKZ0472

Amount application:  $4.5 \pm 0.3\text{mg}$

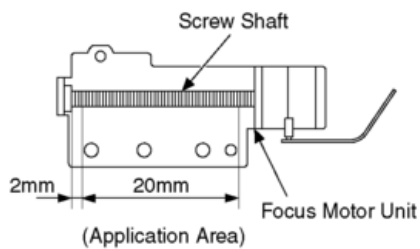

3. Movement the 4th lens frame unit to reference position.

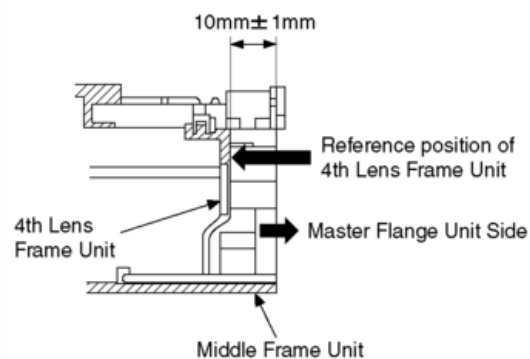

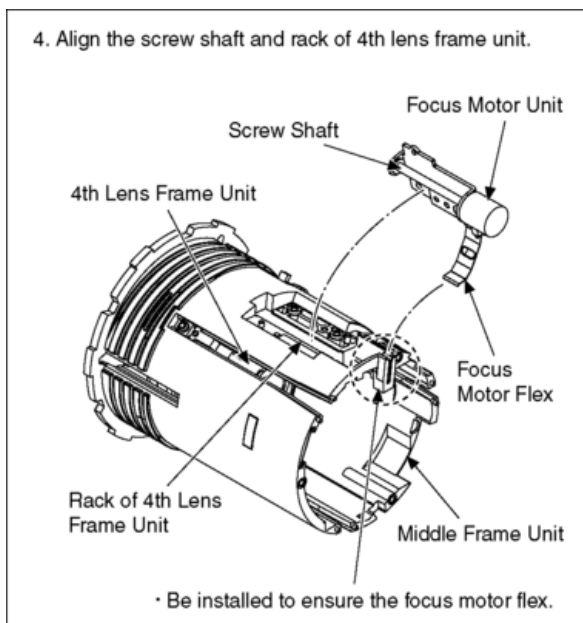

#### 9.4.9 Removal of the 4th and 3rd Lens Frame Unit.

1. Remove the 4th lens frame unit and 3rd lens frame unit from middle frame unit.

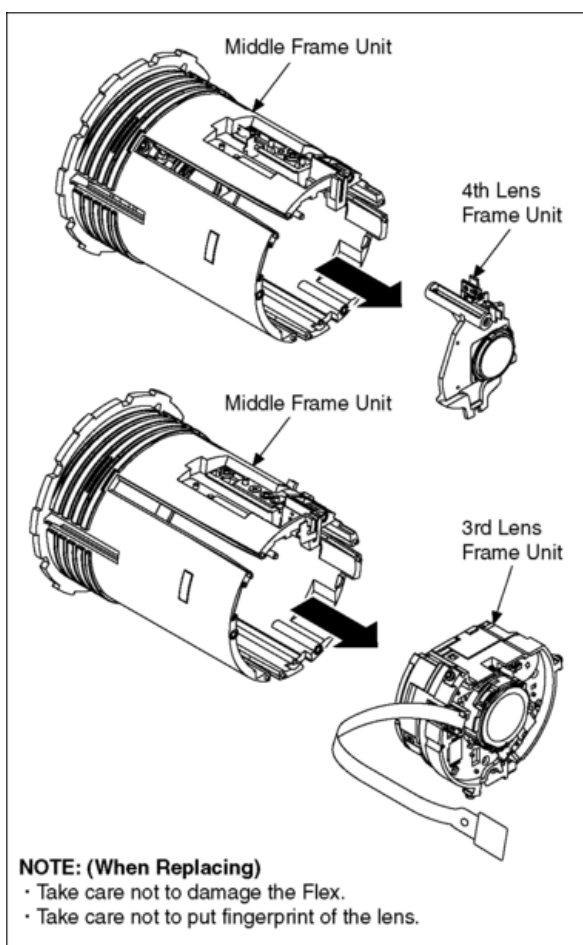



**How to Install**

1. Align the convex of 3rd lens frame unit and groove of middle frame unit, and then install them.

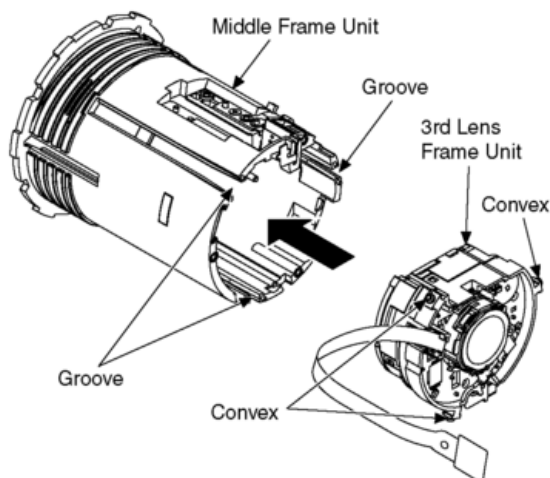

2. Align the hole and groove of 4th lens frame unit and shaft of middle frame unit, and then install them.

- Pass through the flex of 3rd Lens Frame Unit.

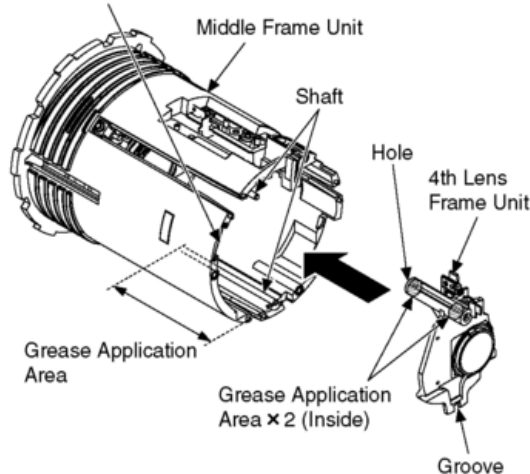
**NOTE: (When Installing)**

- Take care not to damage the Flex.
- Take care not to put fingerprint of the lens.

**■ Grease Application Area**

- Hole of 4th lens frame unit (Inside)  
Grease: RFKZ0472  
Amount of application:  $10 \pm 1 \text{ mg} \times 2$
- Shaft  
Grease: RFKZ0472  
Amount of application:  $1.5 \pm 0.1 \text{ mg}$

## 9.5 Removal of the MOS Unit

When remove the MOS unit once (the screw(E) is loosened even a little), the optical tilt adjustment is required.

When loosen the screw(E), the optical tilt adjustment is necessary at the end of assembling.

(Refer to item "10.3.2.")

To prevent the MOS unit from catching the dust and dirt, do not remove the MOS unit except replacing it.

1. Unscrew the 4 screws(E).
2. Remove the MOS unit.

**IMPORTANT NOTICE:**

- The screw (E) is fixed by the screw locking glue with the optical tilt adjustment finished. When remove the MOS unit, wipe the screw locking glue away.
- Don't reuse the screw (E) that the screw locking glue adheres to keep dust or dirt away from the MOS unit. (When installing, use new screw (E).)

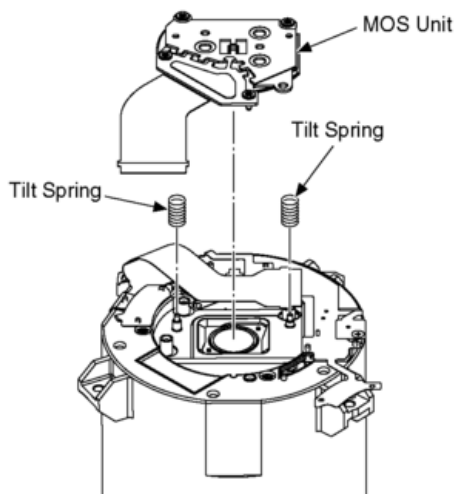
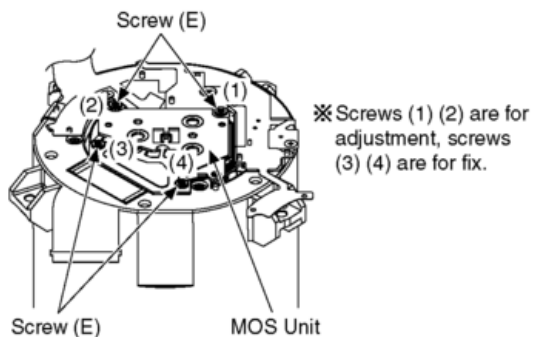

Screw (E)

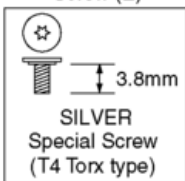

**NOTE: (When Installing)**

- Take new screw.  
(Don't reuse the screw that the screw locking glue adheres.)  
Tighten the screw and torque according to the following order.  
\* Install adjustment driver's bit in the torque driver.  
Tighten the 4 special screws in order (2)→(1)→(4)→(3).
- Screw torque:  $10 \pm 1 \text{ N} \cdot \text{cm}$
- Be sure to execute the optical tilt adjustment with the screw (1) and (2).
- After the adjustment is finished, apply the screw locking glue as shown in the figure below.
- Apply the screw locking glue thinly on the head of screw to the sheet metal with a toothpick.
- Don't apply the screw locking glue where it is applied before disassembling.

Ex)

This is the case where the screw locking glue is applied to the slash area.

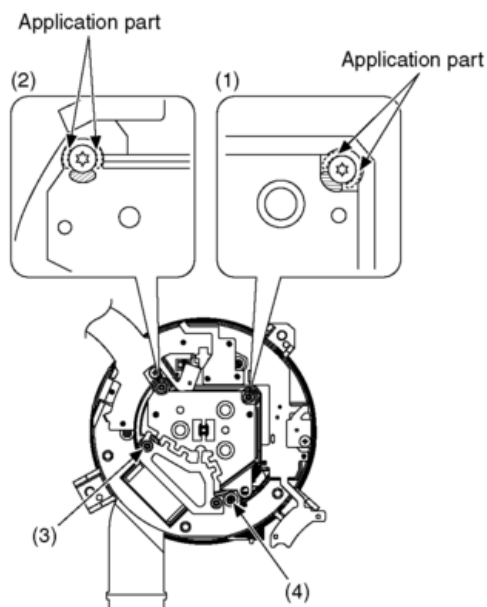

## 9.6 Main exterior parts assembly procedure

This camera is weather sealed.

When assembling this unit, keep the clearance of "0" to "0.2 mm" between the Top Case Unit and Rear Grip to maintain its weather sealing performance.

**(Procedure)**

- Tighten the screws in the order of ① to ④.  
For the screws ①, ③ and ④, tighten them while pushing the Top Case Unit.

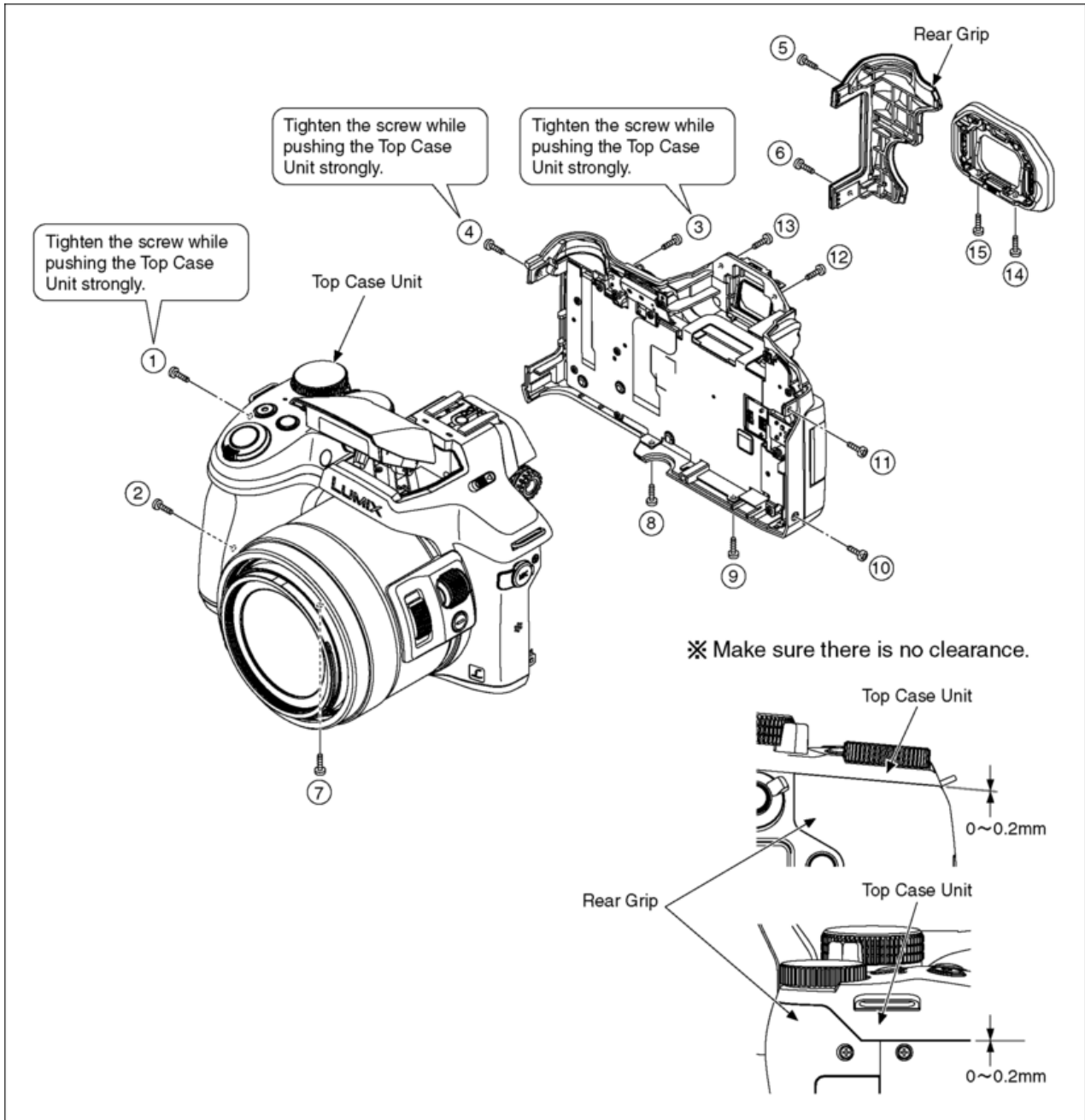

# 10 Measurements and Adjustments

## 10.1 Introduction

When servicing this unit, make sure to perform the adjustments necessary based on the part (s) replaced.  
Before disassembling the unit, it is recommended to back up the camera data stored in Flash-ROM as a data file.

**NOTE: (When replacing the Lens unit, Master Flange Unit and MOS Unit)**

- When the MOS Unit is unavoidably removed for Lens Unit, Master Flange Unit and MOS Unit replaced, an optical tilt adjustment is necessary after parts are exchanged.
- The adjustment software (DSC\_Tilt) is necessary to execute an optical tilt adjustment.
- The adjustment software "DSC\_Tilt" is available at "TSN Website".

**NOTE: (When replacing the Main P.C.B.)**

- Number of necessary adjustment items decreases by copying the backup data to new Main P.C.B. when adjustment data in old Main P.C.B. can be read by ROM\_BACKUP "DSC→SD" in "10.2.2. Flash-ROM Data Backup".  
For more details, please refer an item "Main P.C.B. (to which the backup data was copied)" in the table of "10.3.2. Adjustment Specifications".

## 10.2 Before Disassembling the unit

### 10.2.1 Initial Setting Release

The cameras specification are initially set in accordance with model suffix (such as EB/EG/GN and so on.).  
Unless the initial setting is not released, an automatic alignment software in the camera is not able to be executed when the alignment is carried out.

**Note:**

The initial setting should be again done after completing the alignment. Otherwise, the camera may not work properly.  
Therefore as a warning, the camera display a warning symbol " ! " on the LCD monitor every time the camera is turned off.  
Refer to the procedure described in "3.5.2. Initial Settings" for details.

**[ How to Release the camera initial setting ]**

- Preparation:  
Attach the fully charged Battery, and insert the memory card (32MB or more).  
Remove the lens cap.
- **Step 1. The temporary cancellation of "Initial Settings":**  
Set the [ Mode dial ] to "[ P ](Program AE mode)".  
While pressing [ DISP. ] button, "[ RIGHT ] of Cursor buttons" and [ AF/AE LOCK ] button simultaneously, turn the power on.
- **Step 2. The cancellation of "Initial Settings":**  
Press the [ Playback ] button in order to enter the [ Playback ] mode.  
Press [ AF/AE LOCK ] button and "[ UP ] of Cursor buttons" simultaneously, then turn the power off.  
The LCD displays the " ! " mark before the unit powers down.

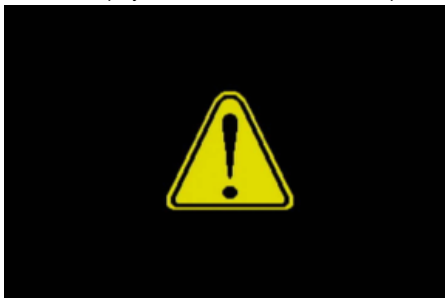

### 10.2.2 Flash-ROM Data Backup

Number of necessary adjustment items decreases by copying the backup data to new Main P.C.B. when adjustment data in old Main P.C.B. is usually read by ROM\_BACKUP "DSC→SD". It is recommended to backup the Flash-ROM data as the way of return when trouble occurs before disassembling the unit depending on each case.

**[ ROM\_BACKUP (Method of Non-PC backup) ]**

1. Insert the memory card into the camera.
2. Set the camera to "Temporary cancellation of the initial settings".
3. Select the "SETUP" menu.  
From the "SETUP" menu, select "ROM\_BACKUP".

**NOTE:**

This item is not listed on the customer's "SETUP" menu.

4. When this "ROM\_BACKUP" item is selected, the following submenus are displayed.

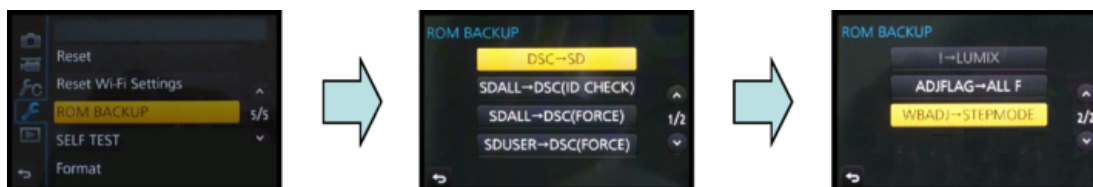

Fig. 2-1

Item	Function	Details
DSC → SD	Save all the DSC's Flash-rom data to Memory Card	<ul style="list-style-type: none"> <li>DSC's Flash-rom data is saved to the Memory Card as a data file. (DATA BACKUP)</li> <li>File location: ROOT DIRECTORY in Memory Card.</li> <li>File Name:               <ol style="list-style-type: none"> <li>User Setup Information data: &lt;Model No.&gt;U.txt [Depending on the model, more than one file may be generated (e.g. &lt;Model No.&gt;U.TXT and &lt;Model No.&gt;U3.TXT).]</li> <li>Electrical Adjustment data: &lt;Model No.&gt;F.txt [Depending on the model, more than one file may be generated (e.g. &lt;Model No.&gt;F.TXT and &lt;Model No.&gt;F3.TXT).]</li> </ol> </li> <li>If the concerned file already exists, "OVERWRITE?" message is displayed.</li> </ul>
SDALL → DSC (ID CHECK)	Write the all data to DSC's Flash-rom from Memory Card	<ul style="list-style-type: none"> <li>The backup data stored in the Memory Card is transferred to DSC unit.</li> <li>ID CHECK: When the model ID is different, data is not transferred.</li> <li>FORCE: Even if the model ID is different, data is transferred.</li> <li>* If the main PCB is replaced, select "SDALL→DSC(FORCE)".</li> </ul>
SDALL → DSC (FORCE)	Write the all data to DSC's Flash-rom from Memory Card	
SDUSER → DSC (FORCE)	Only "User setup information" is written from the saved file in the Memory Card to DSC's Flash-rom.	<ul style="list-style-type: none"> <li>Only the user's "setup" setting condition is transferred to DSC unit.</li> <li>FORCE: Even if the model ID is different, the data is transferred.</li> </ul>
I → LUMIX	Shipping set without initializing "User setup information"	<ul style="list-style-type: none"> <li>Initial setting is executed without initializing the user's set up setting condition.</li> <li>* The initial setting must be performed while the Self-timer LED is blinking.</li> <li>* The picture data stored in the built-in memory of the DSC is not erased, with this operation.</li> </ul>
ADJFLAG → ALL F	Set all adjustment flags completion	<ul style="list-style-type: none"> <li>Status of the all adjustment flags are changed to "F"(completion).</li> </ul>
WBADJ → STEPMODE	ISO: Adjustment WBL, WBM: Setting	<ul style="list-style-type: none"> <li>ISO: Sensitivity adjustment.</li> <li>WBL: Setting up the white in low color temperature.</li> <li>WBM: Setting up the white in high color temperature.</li> </ul>

### 10.2.3 About Light Box

#### How to remove the Front Hood

In order to utilize maximum of the diffusing surface of light box, some adjustment items need the distance between diffusing surface of light box and camera body becomes several cent-meters.

Before the adjustments, remove the front hood of light box following steps below.

[ For RFKZ0523 Light Box ]

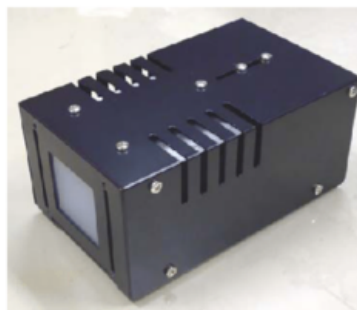
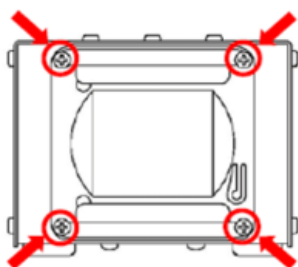

Unscrew the 4 screws, then remove the front hood.

## 10.3 Details of Electrical Adjustment

### 10.3.1 How to execute the Electrical Adjustment

It is not necessary to connect the camera to a PC to perform adjustments.

"Flag reset operation" and "Initial setting operation" are required when carrying out the alignment, follow the procedure below.

#### 10.3.1.1 Startup Electrical Adjustment mode

- Release the initial settings.
- Insert a recordable memory card (32MB or more).  
(Without a memory card, the automatic adjustment can not executed.)
- Procedure to set the camera into adjustment mode:
  - Set the mode dial to "[ P ] (Program AE mode)".
  - Turn the Power on pressing "[ LEFT ] of Cursor buttons" and [ AF/AF LOCK ] button simultaneously. LCD monitor displays "SERVICE MODE". (Refer to Fig. 3-1)

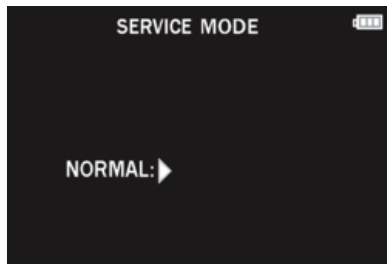

Fig. 3-1

### 10.3.1.2 Status Adjustment Flag Setting

Reset (Not yet adjusted) the status flag condition.

1. After pressing the [ DISP. ] button, the LCD monitor displays the Flag status screen. (Refer to Fig.3-2)
2. Select item by pressing the Cursor buttons. (Gray cursor is moved accordingly.)
3. Press the [ (Delete/Cancel)/Fn3 ] button.

**NOTE:**

The selected item's flag has been changed from "F (green)" to "0 (yellow)".

\*Flag conditions:

F (green)

means that the alignment has been completed and the status flag condition is set. In this case, the flag condition should be reset, if you try to carry out the automatic alignment.

0 (yellow)

means that the alignment has been not "completed" and the status flag condition is "reset". In this case, automatic alignment is available.

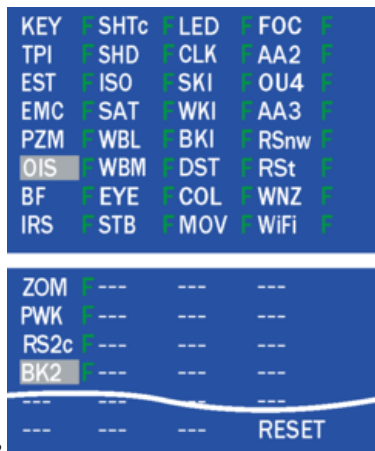

Fig. 3-2

- To display the "BK2" flag, choose the "WiFi" and press the "[ DOWN ] of Cursor buttons".
- In case of setting the status flag into set condition again without completion of the alignment, the status flag should be UNDO by using ROM BACKUP function.

### 10.3.1.3 Execute Adjustment (In case of "OIS Adjustment")

1. Perform step "10.3.1.1." to "10.3.1.2.", to reset the OIS flag status "F" (Set) to "0" (Reset)
2. Press [ DISP. ] button after Flag reset.  
OIS Adjustment screen is displayed on the LCD panel. (Refer to Fig.3-3)
3. Press the [ Shutter ] button.  
The adjustment will start automatically.

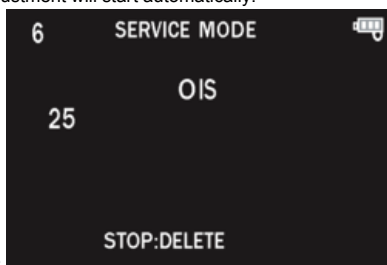

Fig. 3-3

4. When the adjustment is completed successfully, adjustment report menu appears with Green OK on the LCD monitor. (Refer to Fig.3-4)

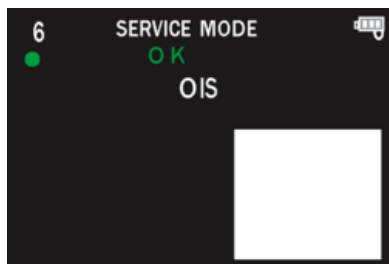

Fig. 3-4

#### 10.3.1.4 Attention point during Adjustment

1. Step "10.3.1.3." procedure shows OIS adjustment as an example. To perform the adjustment, refer to the "10.3.2. Adjustment Specifications" table which shows key point for each adjustment.
2. Do not move the light box, the camera or the chart while adjusting. If one of these is moved accidentally, start the adjustment again.
3. Do not press any buttons/keys until the default menu (Refer to Fig.3-5) is displayed on the LCD monitor. Otherwise, adjustment data may not be stored properly.
4. If the adjustment is interrupted accidentally, the alignment data may not be properly saved in the Flash-ROM.

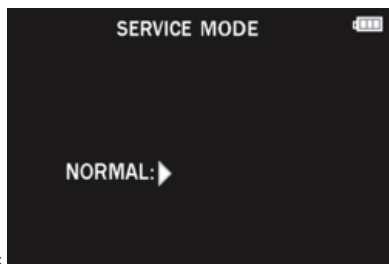

Fig. 3-5

#### 10.3.1.5 Finalizing the Adjustment

1. Several adjustment flags can be reset ("F" into "0") at the same time. In this case, when the adjustment has been completed, the screen will change showing the adjustment for the next item until all reset items are completed.  
Also, when the [ Shutter ] button is pressed, the screen jump to the next adjustment item.
2. To cancel the adjustment mode while in the process of performing the adjustment, follow this procedures.
3. Operate the following, when escaping the Electrical Adjustment mode on the way.
  - (1) Press "[ DISP. ] button".
  - (2) Press "[ RIGHT ] of Cursor buttons".

**NOTE:**

- If adjustment is cancelled with above procedure, adjustment is not completed. Make sure to adjust it later.

### 10.3.2 Adjustment Specifications

The following matrix table shows the relation between the replaced part and the Necessary Adjustment. When a part is replaced, make sure to perform the necessary adjustment(s) in the order indicated. The table below shows all the information necessary to perform each adjustment.

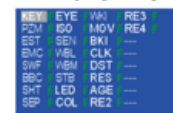

Adjustment order	Adjustment Item	FLAG	Purpose	Replacing Parts							JIG/TOOLS	SET UP	How to Operate		
				MAIN P.C.B./Flash-ROM/VENUS ENGINE	MAIN P.C.B. (When written Backup data)	Lens Part (Excluding Image Sensor)	Image Sensor	Microphone	Flash Part	Electronic Level (IC6201)				Eye Sensor	
1	Optical Tilt	—	Adjustment of MOS Unit installation angle to the Lens	—	—	○	○	—	—	—	—	—	<p><b>NOTE:</b> It is necessary to use the "DSC_Tilt" software to allow the "Optical tilt adjustment". The Adjustment software "DSC_Tilt" is available at "TSN Website".</p> <ul style="list-style-type: none"> <li>• Optical Tilt Adjustment Chart RFKZ0570</li> <li>• Optical Tilt Adjustment Driver RFKZ0569: T4</li> <li>• Camera Stand RFKZ0333J</li> <li>• Torque Driver RFKZ0542</li> </ul> <p>* The screw locking glue is necessary, after adjustment.</p>		
2	Venus Zoom	PZM	Venus Zoom inspection	○	○	—	—	—	—	—	—	NONE	NONE	<ol style="list-style-type: none"> <li>1) Change the flag into the "0", and then proceed to the adjustment mode.</li> <li>2) Press the shutter button fully. (When a result is OK, it is the completion of an inspection.)</li> </ol>	
3	OIS sensor	OIS	OIS sensor output level adjustment	○	—	○	○	—	—	—	—	NONE	NONE	<ol style="list-style-type: none"> <li>1) Change the flag into the "0", and then proceed to the adjustment mode.</li> <li>2) Press the shutter button fully. (When a result is OK, it is the completion of an inspection.)</li> </ol>	
4	Backfocus / GYRO	BF	To have the focus tracking curve be appropriate shape and GYRO sensor adjustment	○	○	○	○	—	—	—	—	<ul style="list-style-type: none"> <li>• Collimator RFKZ0422</li> </ul>	<ol style="list-style-type: none"> <li>1) Set the camera in front of collimator so that the distance between collimator and camera body becomes 2.0 cm as shown in Fig. A. (It is not distance between lens barrel top and diffusing surface of light box.)</li> <li>* Set the camera on a tripod to prevent it from falling down.</li> </ol>	<ol style="list-style-type: none"> <li>1) Change the flag into the "0", and then proceed to the adjustment mode.</li> <li>2) Set the camera angle so that the star chart is displayed to the center, and press the shutter button fully. (Green ● mark is displayed on LCD.)</li> <li>3) Press the shutter button fully, again. (When a result is OK, it is the completion of an inspection.)</li> </ol>	
5	Iris	IRS	Iris adjustment	○	—	○	○	—	—	—	—	<ul style="list-style-type: none"> <li>• Light Box RFKZ0523</li> </ul>	<ol style="list-style-type: none"> <li>1) Set the camera in front of light box so that the distance between diffusing surface of light box and camera body becomes 2.0 cm as shown in Fig. B. (It is not distance between lens barrel top and diffusing surface of light box.)</li> </ol>	<ol style="list-style-type: none"> <li>1) Change the flag into the "0", and then proceed to the adjustment mode.</li> <li>2) Set the camera angle so that the diffusing surface of light box is displayed on the full of LCD monitor, and press the shutter button fully. (When a result is OK, it is the completion of an inspection.)</li> </ol>	
6	Shutter	SHTc	Shutter speed adjustment	○	—	○	○	—	—	—	—	<ul style="list-style-type: none"> <li>• Light Box RFKZ0523</li> </ul>	<ol style="list-style-type: none"> <li>1) Set the camera in front of light box so that the distance between diffusing surface of light box and camera body becomes 2.0 cm as shown in Fig. B. (It is not distance between lens barrel top and diffusing surface of light box.)</li> </ol>	<ol style="list-style-type: none"> <li>1) Change the flag into the "0", and then proceed to the adjustment mode.</li> <li>2) Set the camera angle so that the diffusing surface of light box is displayed on the center of LCD monitor, and press the shutter button fully. (When a result is OK, it is the completion of an inspection.)</li> </ol>	
		SHD	Do not use "SHD" adjustment flag for this unit. Use "BK2" adjustment flag, instead.												

Adjustment order	Adjustment Item	FLAG	Purpose	Replacing Parts							JIG/TOOLS	SET UP	How to Operate
				MAIN P.C.B./Flash-ROM/VEHICUS ENGINE	MAIN P.C.B. (When written Backup data)	Lens Part (Excluding Image Sensor)	Image Sensor	Microphone	Flash Part	Electronic Level (LC6201)			
<p>• Set "STEPMODE" to adjust 7: ISO, 8: WBL and 9: WBM.                      &lt;How to switch to "STEPMODE"&gt;                      1. Perform "10.2.2. Flash-ROM Data Backup", and select "WBADJ → STEPMODE" for ROM_BACKUP.                      2. Press "SET", and move to the flag setting screen at "STEPMODE".                      ⇒ The screen appears on the LCD. (See Fig. on the right.)</p>													
<div style="display: flex; justify-content: space-around;"> <div style="text-align: center;"> <p>Normal flag setting screen</p>  </div> <div style="text-align: center;"> <p>[STEPMODE] flag setting screen</p>  </div> </div>													
7	ISO	ISO	ISO sensitivity adjustment	<input type="radio"/>	<input type="radio"/>	<input type="radio"/>	<input type="radio"/>	<input type="radio"/>	<input type="radio"/>	<input type="radio"/>	<ul style="list-style-type: none"> <li>• Light Box RFKZ0523</li> <li>• ND0.3 Filter RFKZ0513</li> </ul>	1) Set the camera in front of light box so that the distance between diffusing surface of light box and camera body becomes <b>2.0 cm</b> as shown in Fig. B. (It is not distance between lens barrel top and diffusing surface of light box.)	1) Change the flag into the "0", and then proceed to the adjustment mode. 2) Set the camera angle so that the diffusing surface of light box is displayed on the center of LCD monitor, and press the shutter button fully. (When a result is OK, it is the completion of an inspection.)
8	White balance (Low color temp.)	WBL	Setting up the white in low color temperature	<input type="radio"/>	<input type="radio"/>	<input type="radio"/>	<input type="radio"/>	<input type="radio"/>	<input type="radio"/>	<input type="radio"/>	<ul style="list-style-type: none"> <li>• Light Box RFKZ0523</li> <li>• ND0.9 Filter VFK1164ND09</li> <li>• ND0.3 Filter RFKZ0513</li> <li>• CC-C7.5 Filter RFKZ0511</li> </ul>	1) Set the camera in front of light box so that the distance between diffusing surface of light box and camera body becomes <b>2.0 cm</b> as shown in Fig. B. (It is not distance between lens barrel top and diffusing surface of light box.)	1) Change the flag into the "0", and then proceed to the adjustment mode. 2) Set the camera angle so that the diffusing surface of light box is displayed on the center of LCD monitor, and press the shutter button fully. (When a result is OK, it is the completion of an inspection.)
9	White balance (High color temp.)	WBM	Setting up the white in high color temperature	<input type="radio"/>	<input type="radio"/>	<input type="radio"/>	<input type="radio"/>	<input type="radio"/>	<input type="radio"/>	<input type="radio"/>	<ul style="list-style-type: none"> <li>• Light Box RFKZ0523</li> <li>• ND0.9 Filter VFK1164ND09</li> <li>• ND0.3 Filter RFKZ0513</li> <li>• CC-C7.5 Filter RFKZ0511</li> <li>• CC-Y10 Filter RFKZ0512</li> <li>• LBB2 Filter RFKZ0520</li> <li>• LBB8 Filter RFKZ0521</li> </ul>	1) Set the camera in front of light box so that the distance between diffusing surface of light box and camera body becomes <b>2.0 cm</b> as shown in Fig. B. (It is not distance between lens barrel top and diffusing surface of light box.)	1) Change the flag into the "0", and then proceed to the adjustment mode. 2) Set the camera angle so that the diffusing surface of light box is displayed on the center of LCD monitor, and press the shutter button fully. (When a result is OK, it is the completion of an inspection.)
<p>• After adjusting 7: ISO, 8: WBL and 9: WBM, perform Initial Settings once. Then, cancel "STEPMODE". Then again, cancel the Initial Settings. Move to the servicing mode, and continue the subsequent adjustment.</p>													
10	Offset gain	SAT	Setting up the offset gain	<input type="radio"/>	<input type="radio"/>	<input type="radio"/>	<input type="radio"/>	<input type="radio"/>	<input type="radio"/>	<input type="radio"/>	<ul style="list-style-type: none"> <li>• Light Box RFKZ0523</li> <li>• ND0.6 Filter VFK1164ND06</li> </ul>	1) Insert the ND0.6 filter into the slot of light box as shown in Fig. D. 2) Set the camera in front of light box so that the distance between diffusing surface of light box and camera body becomes <b>2.0 cm</b> as shown in Fig. B.	1) Change the flag into the "0", and then proceed to the adjustment mode. 2) Set the camera angle so that whiten is displayed on the LCD monitor fully. 3) Press the shutter button fully. (When a result is OK, it is the completion of an inspection.)
11	Eye sensor	EYE	Inspecting sensitivity of eye sensor	<input type="radio"/>	<input type="radio"/>	<input type="radio"/>	<input type="radio"/>	<input type="radio"/>	<input type="radio"/>	<input type="radio"/>	<ul style="list-style-type: none"> <li>• Gray Card RFKZ0506</li> </ul>	1) Set the camera in front of gray card so that the distance between gray card and eye sensor of camera body becomes <b>4.5 cm</b> as shown in Fig. C.	1) Change the flag into the "0", and then proceed to the adjustment mode. 2) Set the camera angle so that the attachment side of eye sensor and center of the gray card is perpendicular, and press the shutter button fully. (When a result is OK, it is the completion of an inspection.)
12	Flash adjustment	STB	Flash adjustment	<input type="radio"/>	<input type="radio"/>	<input type="radio"/>	<input type="radio"/>	<input type="radio"/>	<input type="radio"/>	<input type="radio"/>	NONE	NONE	1) Change the flag into the "0", and then proceed to the adjustment mode. 2) Press the shutter button fully. 3) Check that a flash shines. (It is different for every model how many times it shines.) * When a flash does not shine, there is a possibility that the flash unit is out of order. 4) Check a test result. * Results of the tests are usually NG. (When a result is OK, it is the completion of an inspection.) 5) When a result is NG, rewrite STB flag to an adjustment using <b>ADJFLG → ALL F of ROM BACKUP</b> . * The flag "STB" is an item which checks shines operation of a flash automatically at a Manufacturing facility. For this reason, except environment for exclusive use, a result will be NG. but it is no problem if shines operation can be checked visually.

Adjustment order	Adjustment Item	FLAG	Purpose	Replacing Parts							JIG/TOOLS	SET UP	How to Operate
				MAIN P.C.B./Flash-ROM/VEHUS ENGINE	MAIN P.C.B. (When written Backup data)	Lens Part (Excluding Image Sensor)	Image Sensor	Microphone	Flash Part	Electronic Level (IC6201)			
13	MOS sensor Temp. white missing pixels *2	SKI	Registration of the Temp. white missing pixels	○	—	○	—	—	—	—	NONE	NONE	1) Change the flag into the "0", and then proceed to the adjustment mode. 2) Press the shutter button fully. (When a result is OK, it is the completion of an inspection.)
14	MOS sensor FD white missing pixels *2	WKI	Registration of the FD (floating diffusion) white missing pixels	○	—	○	+	—	—	—	NONE	NONE	1) Change the flag into the "0", and then proceed to the adjustment mode. 2) Press the shutter button fully. (When a result is OK, it is the completion of an inspection.)
		BKI	Do not use "BK1" adjustment flag for this unit. Use "BK2" adjustment flag, instead. (In case of most DSC models, the adjustment flag for MOS SENSOR Missing Pixels is "BK1". But, in this model, "BK2" the adjustment flag for MOS SENSOR Missing Pixels.)										
15	Color reproduction inspection Microphone check	COL	Color reproduction inspection and Microphone check	○	—	○	○	○	—	—	NONE	NONE	1) Change the flag into the "0", and then proceed to the adjustment mode. 2) Press the shutter button fully. 3) Utter the voice for about 5 seconds into the microphone, just before pushing a shutter release. * Utter the voice at the above the LVF. * Comparatively high voice is ideal. (Standard: about 1KHz) (When a result is OK, it is the completion of an inspection.)
16	Electronic Level	AA2 + AA3	Electronic Level adjustment	○	○	—	—	—	—	○	—	ACC Adjustment Chart	1) Download the "ACC Adjustment chart .pdf" and print it to A3 size (or equivalent size) paper. ("ACC Adjustment chart .pdf" is available at "TSN Website". To download, click on "Support information from NWBG/VDBG -AVC") 2) Hang in the string with weight, then put the printed ACC adjustment chart on the wall or panel horizontally. (Fig. 1) * After putting the adjustment chart horizontally, remove the string with weight. * Attach the camera to tripod. <Setup procedures> 3-1) Adjust the height of tripod to match the lens of camera and center of the adjustment chart. 3-2) Apply the triangle (or equivalent) in center of the chart, then adjust center of the lens of camera on the vertical extension. 3-3) Confirm that the chart is displayed on the LCD monitor fully. 3-4) Fine adjust the camera angle so that the horizontal bar of chart is displayed horizontally on the LCD monitor and matches the cross guide line of the LCD monitor. (Fig. 2) 1) Change the flag "AA2" and "AA3" into the "0", and then press DISPLAY button and proceed to the adjustment mode. <Offset adjustment> 2) Set the camera to the horizontal position. Then set the distance between adjustment chart and camera body becomes 28 cm. And optical axis of the lens and center of the chart crosses right-angled. (Fig. 3) 3) Press the shutter button fully. (When a result is OK, it is the completion of an inspection.) <Tilt adjustment> 4) Rotate the camera to the 90 degrees, so that the grip side down, and press the shutter button. (Fig. 4) 5) Set the camera to the horizontal position, and press the shutter button. (Fig. 5) 6) Rotate the camera to the 90 degrees, so that the grip side up, and press the shutter button. (Fig. 6) (When a result is OK, it is the completion of an inspection.)

**Fig.1:**  
Setting of the adjustment chart horizontally

Fix by pins (or equivalent)

Install the adjustment chart so that the both marking top and bottom of chart overlaps with the string.

Hung string with weight

**Fig.2:**  
Setting of the camera to the front of adjustment chart

[ Top View ]

Triangle

ACC Adjustment Chart

CAMERA

**Fig.3:**  
[ Offset ]  
(Horizontal Position)

**Fig.4:**  
[ Vertical Position ]  
(Grip side Down)

**Fig.5:**  
[ Horizontal Position ]

**Fig.6:**  
[ Vertical Position ]  
(Grip side Up)

Adjustment order	Adjustment Item	FLAG	Purpose	Replacing Parts							JIG/TOOLS	SET UP	How to Operate	
				MAIN P.C.B./Flash-ROM/VEHICUS ENGINE	MAIN P.C.B. (When written Backup data)	Lens Part (Excluding Image Sensor)	Image Sensor	Microphone	Flash Part	Electronic Level (C6201)				Eye Sensor
17	Shading Compensation and MOS SENSOR Missing Pixels (Black) *3	BK2	Compensation of Shading and Compensation of MOS SENSOR Missing Pixels (Black)	O	O	*1						<ul style="list-style-type: none"> <li>• Light Box RFKZ0523</li> <li>• Diffuser RFKZ0591</li> </ul>	1) Set the Diffuser to diffusing surface of light box.	<ol style="list-style-type: none"> <li>1) Change the flag into the "0", and then proceed to the adjustment mode. (BK2 flag is 2nd pages.)</li> <li>2) Press the shutter button fully. → Green ● mark is displayed on LCD.</li> <li>3) Attach the Camera Lens on the Diffuser. And set the camera angle so that the diffusing surface of light box is displayed on the full of LCD monitor, and press the shutter button fully. → The 1st adjustment is executed, and then Green ● mark is displayed on LCD.</li> <li>4) Separate the camera body from light box, and press the shutter button fully. → The lens starts zooming and stops automatically, then green ● mark is displayed on LCD.</li> <li>5) Attach the Camera Lens on the Diffuser. And set the camera angle so that the diffusing surface of light box is displayed on the full of LCD monitor, and press the shutter button fully. → The 2nd adjustment is executed, and then Green ● mark is displayed on LCD.</li> <li>6) Separate the camera body from light box, and press the shutter button fully. → The lens starts zooming and stops automatically, then green ● mark is displayed on LCD.</li> <li>7) Attach the Camera Lens on the Diffuser. And set the camera angle so that the diffusing surface of light box is displayed on the full of LCD monitor, and press the shutter button fully. → The 3rd adjustment is executed. When a result is OK, it is the completion of an inspection.</li> </ol>
Wi-Fi check	Wi-Fi	Do not use "WiFi" adjustment flag for servicing. This adjustment is for factory procedure. (For confirmation of Wi-Fi function, use the reception of Wi-Fi access point as usual.)												

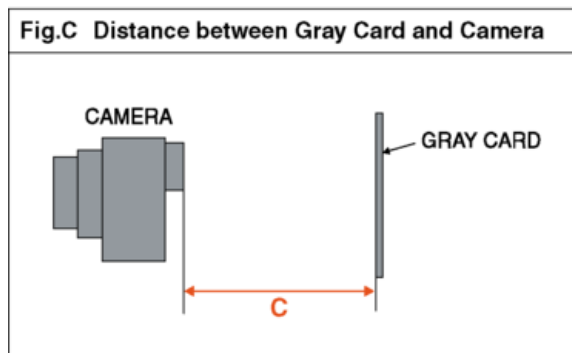
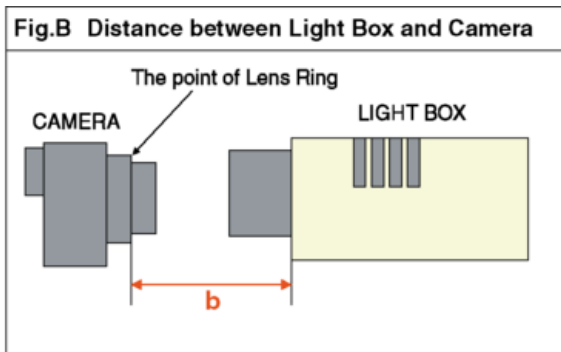
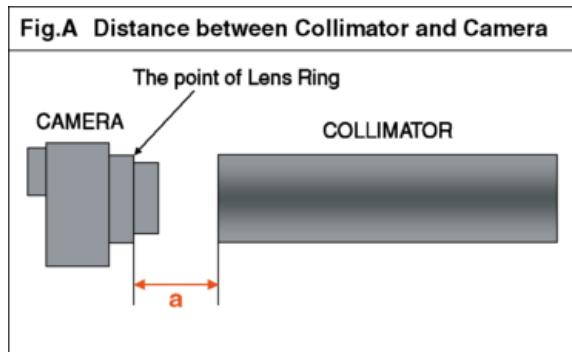

\*1. This adjustment must be performed not only replacing the MOS unit, but also simply removing the MOS unit.

\*2. The pixel that always lights while shaded is called a white wound.

\*3. The pixel that does not light while complete exposed is called a black wound.

**IMPORTANT NOTICE: (After replacing the Main P.C.B. (Venus Engine is included) or Venus Engine)**

After replacing the Main P.C.B. (Venus Engine is included) or Venus Engine, make sure to perform the "Initial Settings" first, then release the "Initial Settings" in order to proceed the electrical adjustment.

**NOTE:**

1. If electrical adjustment or data re-writing is executed before "Initial Settings", suffix code list is never displayed, and it cannot be chosen suitable suffix code.
2. Never remove the battery during initial setting in process.

## 10.4 After Adjustment

### 10.4.1 Initial Setting

Since the initial setting has been released to execute the built-in adjustment software, it should be set up again before shipping the camera to the customer.

Refer to the procedure described in "3.5.2. Initial Settings" for details.

**[ IMPORTANT ]**

1. The initial setting should be done again after completing the alignment. Otherwise, the camera will not work properly. Therefore as a warning, the camera display a warning symbol " ! " on the LCD monitor every time the camera is turned off.
2. Confirm that status of all adjustment flag show "F". Even if one of the adjustment flag shows "0", initial setting programmed is never executed.

# 11 Maintenance

## 11.1 Cleaning Lens and LCD Panel

Do not touch the surface of lens and LCD Panel with your hand.

When cleaning the lens, use air-blower to blow off the dust.

When cleaning the LCD Panel, dampen the lens cleaning paper with lens cleaner, and the gently wipe the its surface.

**Note:**

The Lens Cleaning Kit ; VFK1900BK (Only supplied as 10 set/Box) is available as Service Aid.

---

**Model No. : DMC-FZ300/330 Schematic Diagram Note**

---

**IMPORTANT SAFETY NOTICE:**

COMPONENTS IDENTIFIED WITH THE MARK  HAVE THE SPECIAL CHARACTERISTICS FOR SAFETY. WHEN REPLACING ANY OF THESE COMPONENTS USE ONLY THE SAME TYPE.

1. Although reference number of the parts is indicated on the P.C.B. drawing and/or schematic diagrams, it is NOT mounted on the P.C.B. when it is displayed with "\$" mark.
2. It is only the "Test Round" and no terminal (Pin) is available on the P.C.B. when the TP (Test Point) indicated as "●" mark.
3. Use the parts number indicated on the Replacement Parts List .
4. Indication on Schematic diagrams:

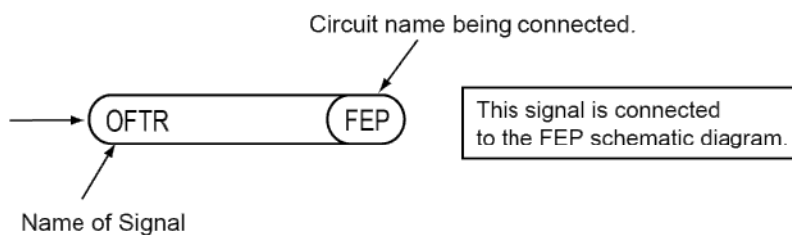

5. It might be taking time for display and/or access of the Schematic Diagrams & P. C. B having the heavy data volume.

---

**Model No. : DMC-FZ300/330    Parts List Note**

---

- Note:
1. \* Be sure to make your orders of replacement parts according to this list.
  2. **IMPORTANT SAFETY NOTICE**  
Components identified with the mark  $\triangle$  have the special characteristics for safety.  
When replacing any of these components, use only the same type.
  3. Unless otherwise specified,  
All resistors are in OHMS, K=1,000 OHMS. All capacitors are in MICRO-FARADS (uf), P=uuF.
  4. The marking (RTL) indicates the retention time is limited for this item. After the discontinuation of this assembly in production, it will no longer be available.
  5. Supply of CD-ROM, in accordance with license protection, is allowable as replacement parts only for customers who accidentally damaged or lost their own.

**E.S.D. standards for Electrostatically Sensitive Devices, refer to PREVENTION OF ELECTROSTATIC DISCHARGE (ESD) TO ELECTROSTATICALLY SENSITIVE (ES) DEVICES section.**

**Definition of Parts supplier:**

1. Parts marked with [ENERGY] in the remarks column are supplied from Panasonic Corporation Energy Company.
2. Parts marked with [INBD] in the remarks column are supplied from INBD.  
Others are supplied from PAVCX.



**Model No. : DMC-FZ300/330 Power (P) (Main P.C.B.)**

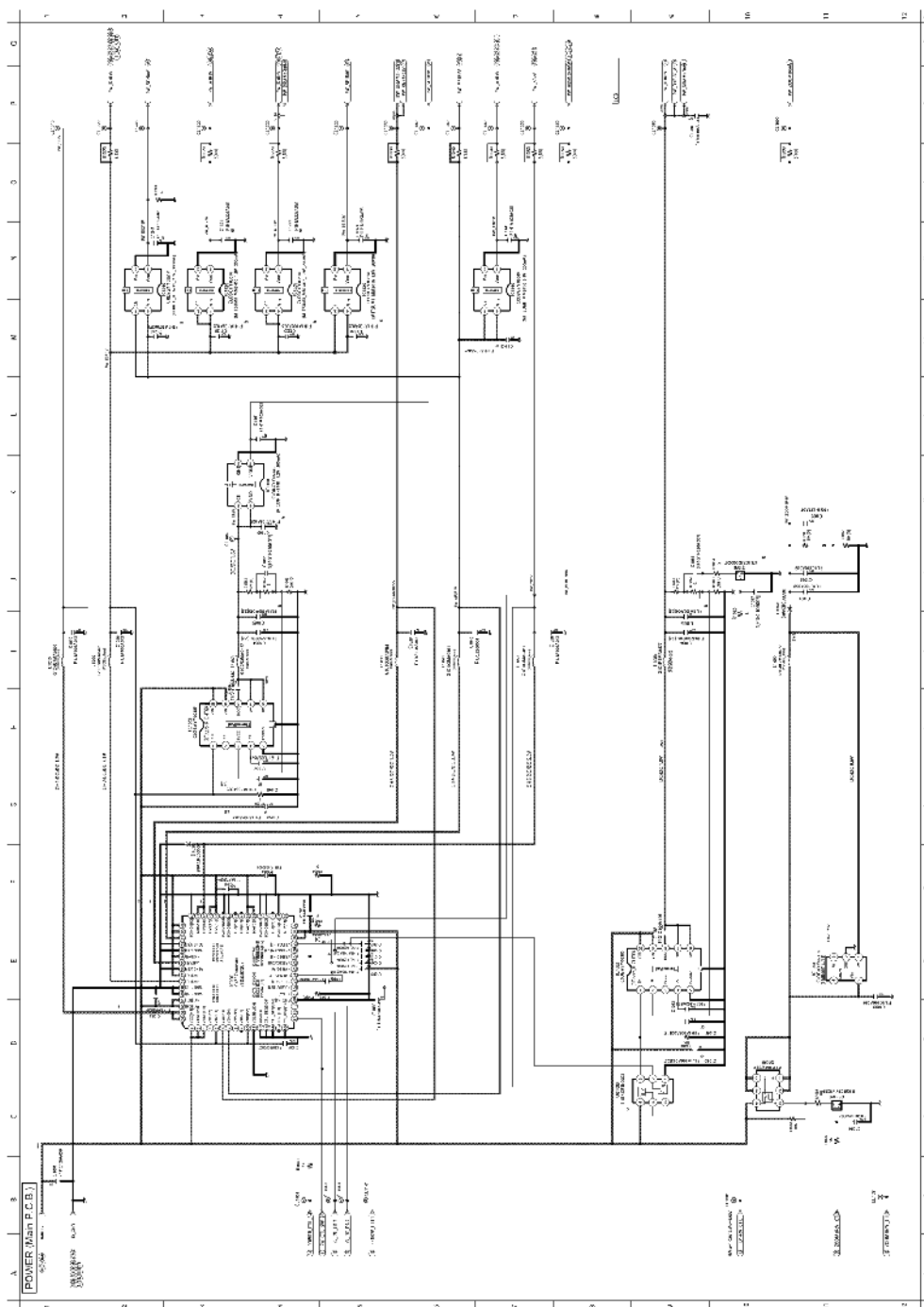

# Model No. : DMC-FZ300/330 Jack (J) (Main P.C.B.)

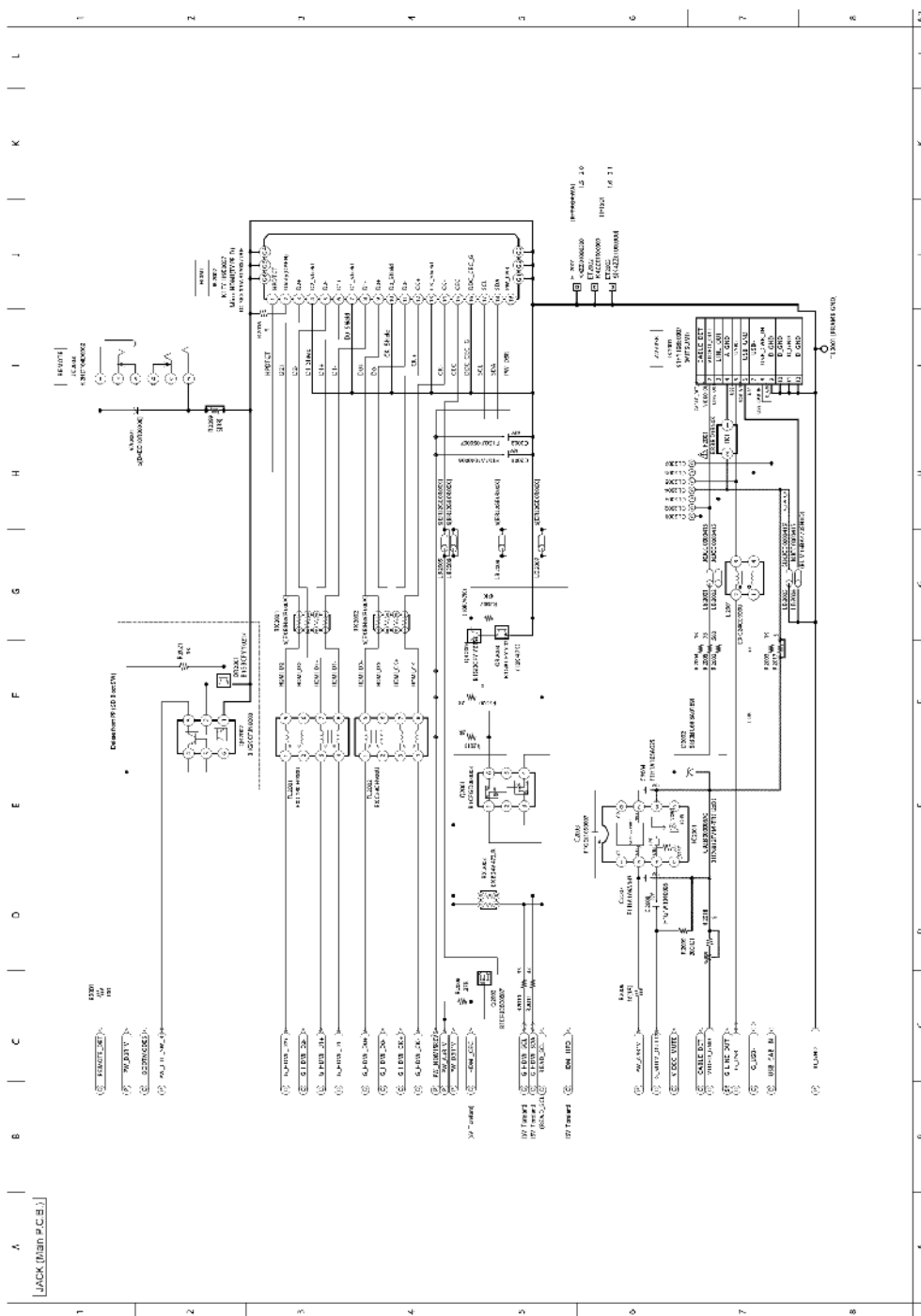

**Model No. : DMC-FZ300/330 MIC Selector (MS) (Main P.C.B.)**

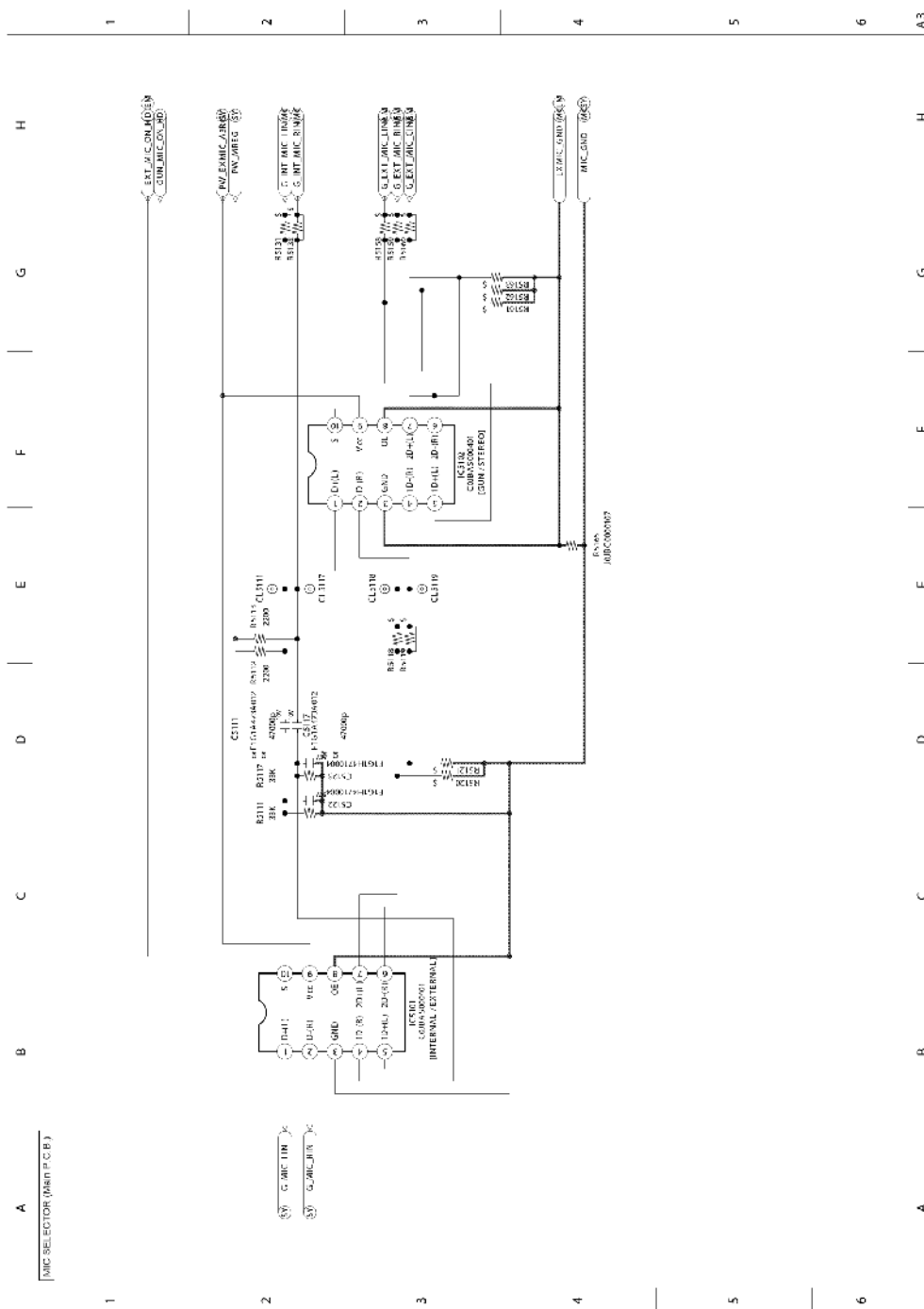

**Model No. : DMC-FZ300/330 EXT MIC (EM) (Main P.C.B.)**

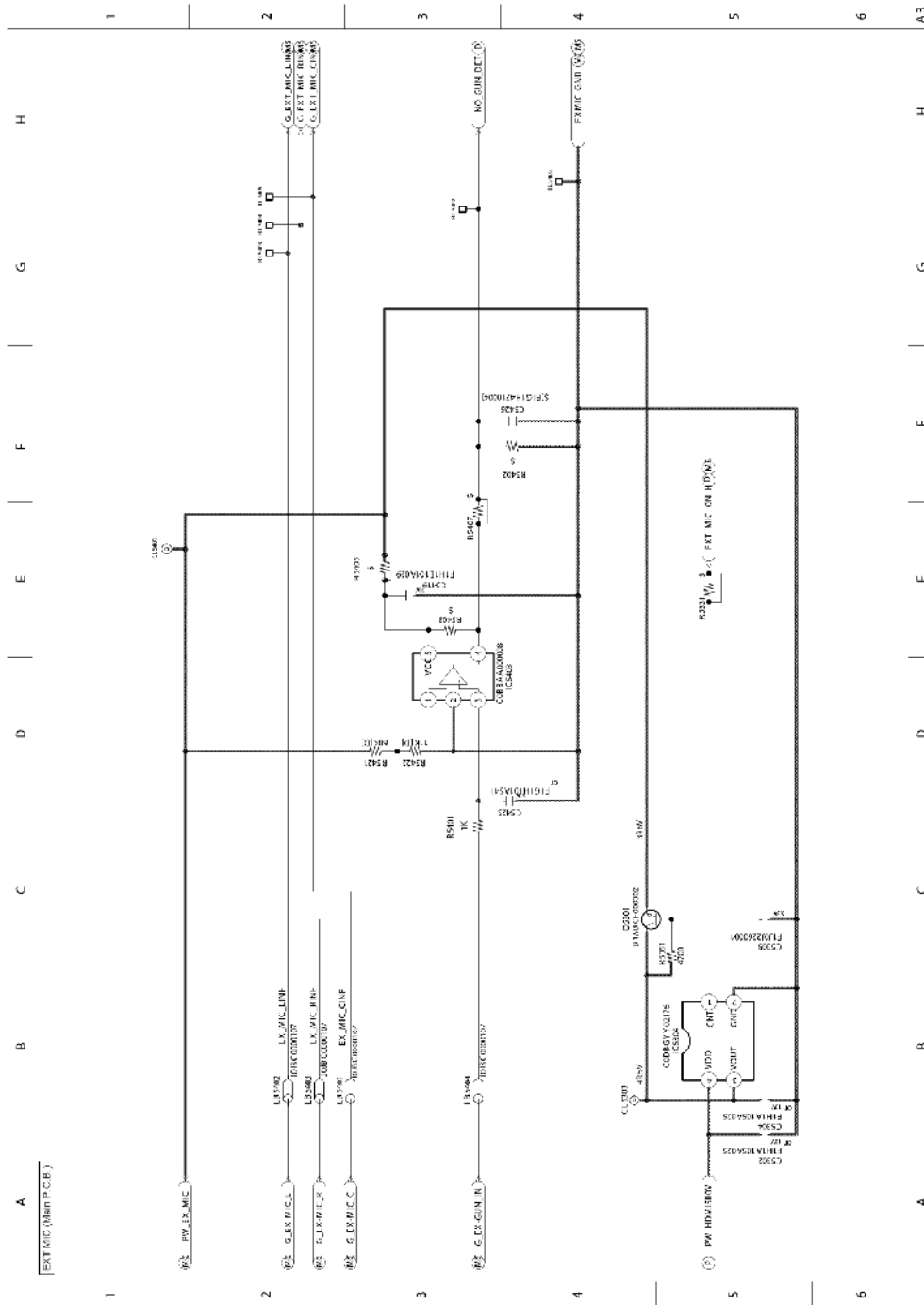

Model No. : DMC-FZ300/330 Digital (D) (Main P.C.B.)

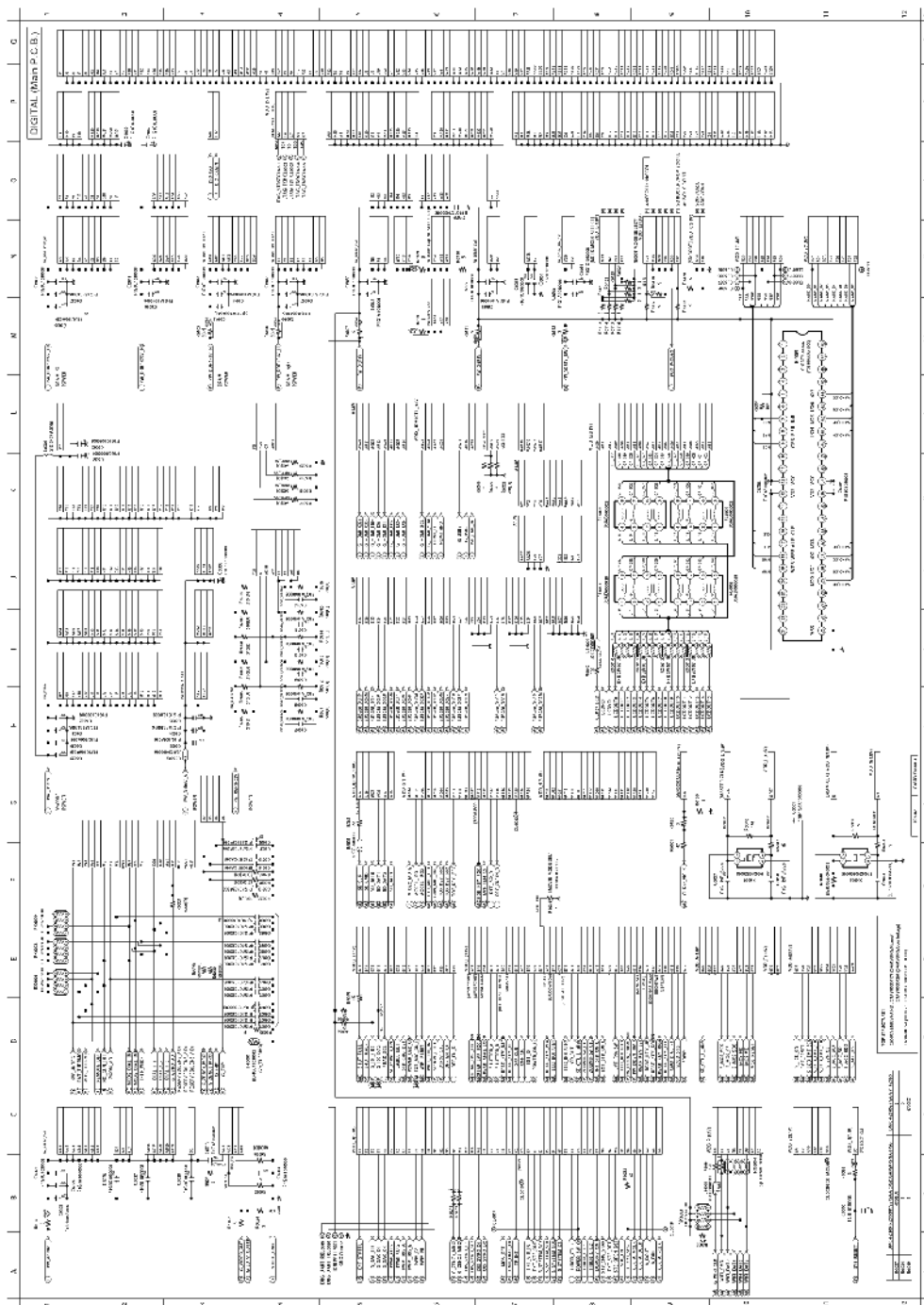

# Model No. : DMC-FZ300/330 SD Card (SD) (Main P.C.B.)

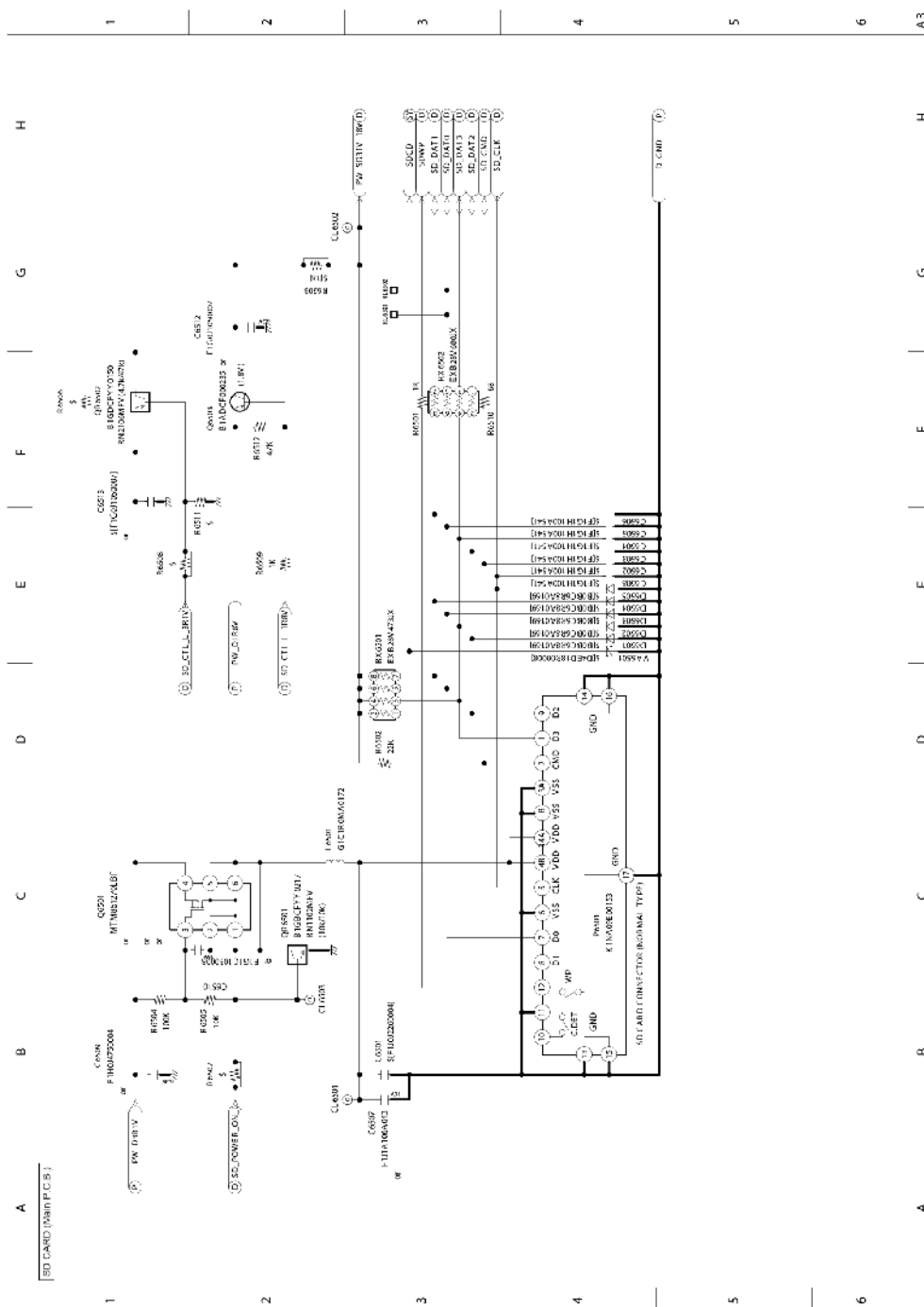

**Model No. : DMC-FZ300/330 Acceleration (AC) (Main P.C.B.)**

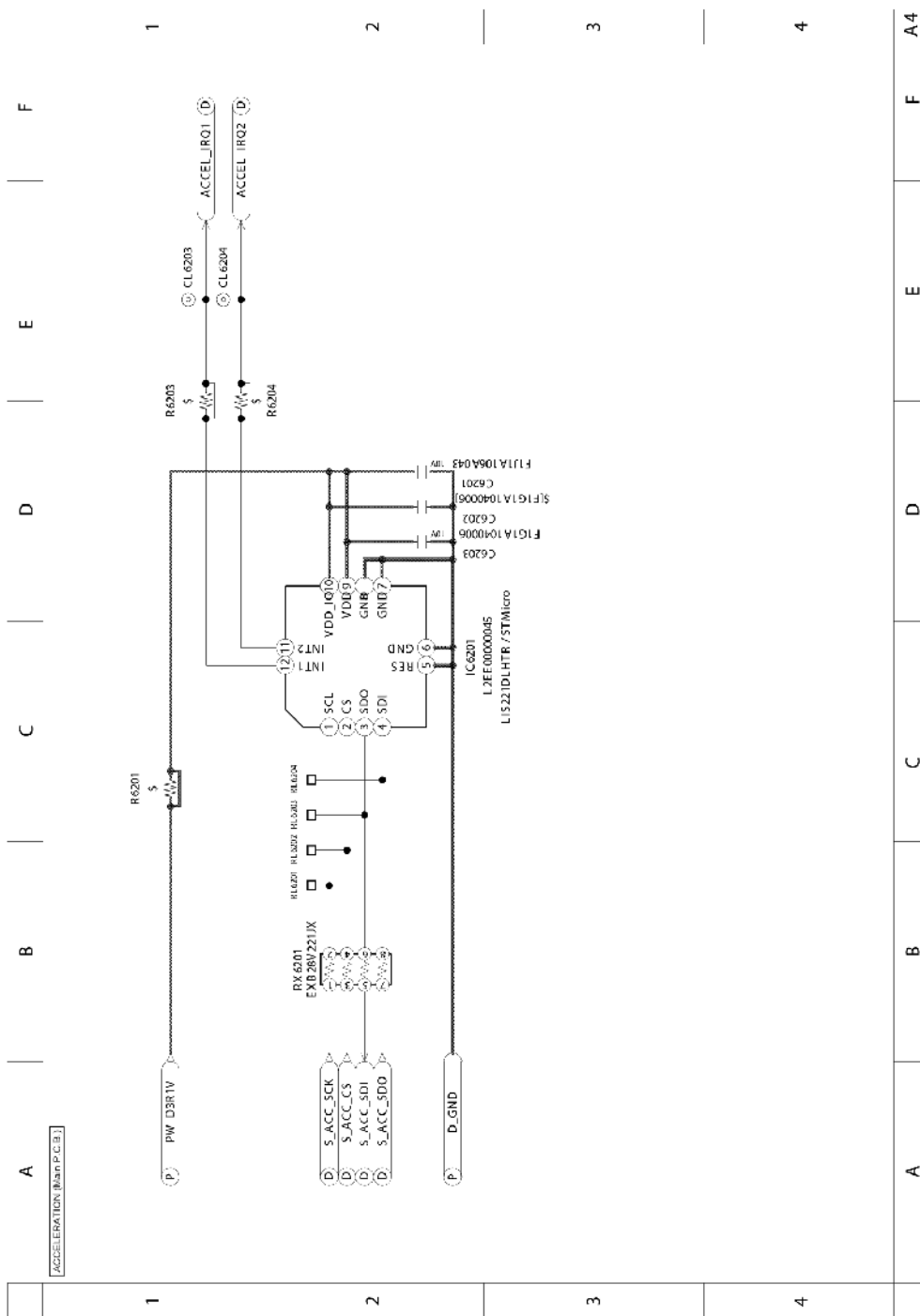

Model No. : DMC-FZ300/330 Hibernation (HI) (Main P.C.B.)

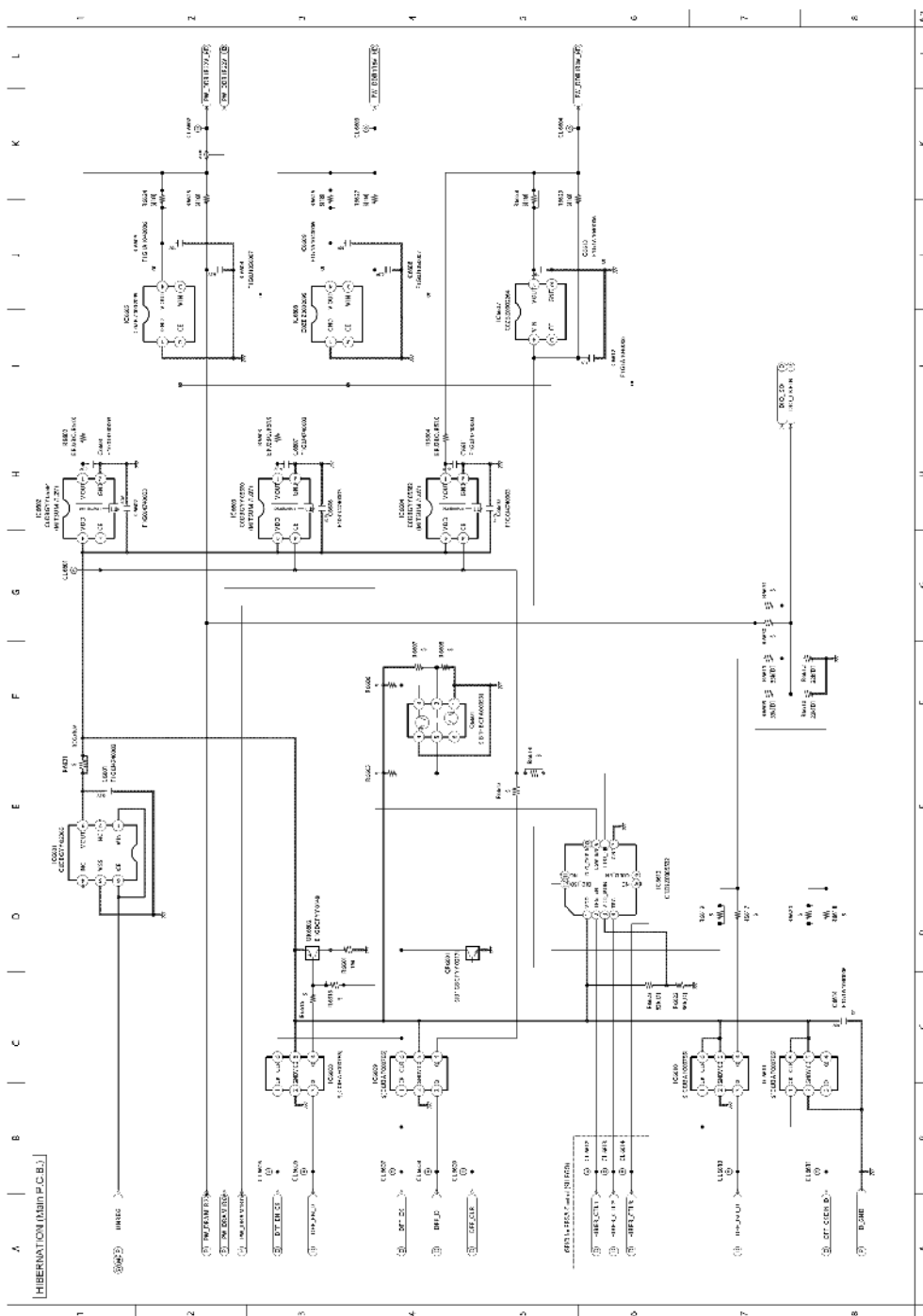



**Model No. : DMC-FZ300/330 Gyro (GY) (Main P.C.B.)**

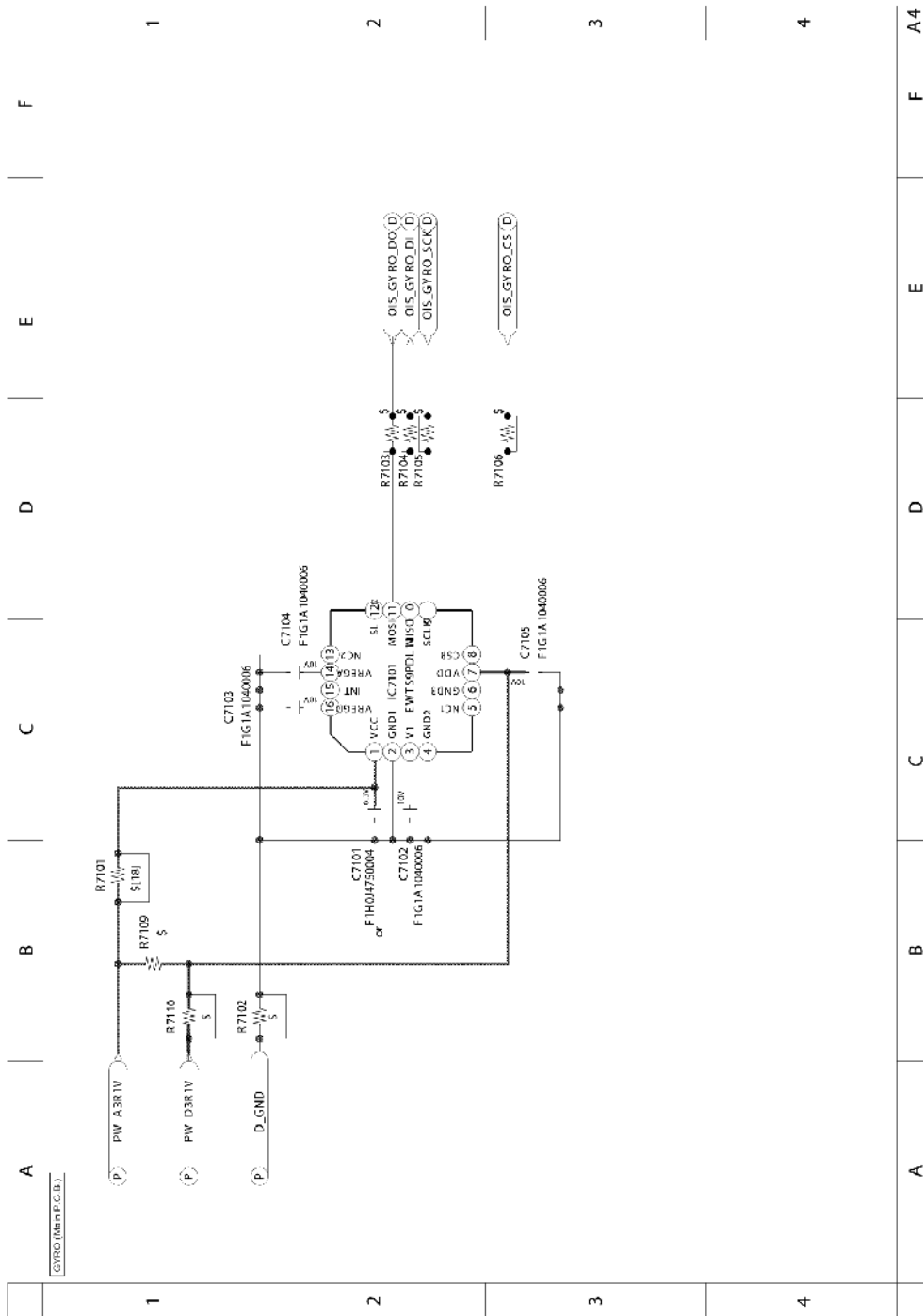

**Model No. : DMC-FZ300/330 Hot Shoe (HS) (Main P.C.B.)**

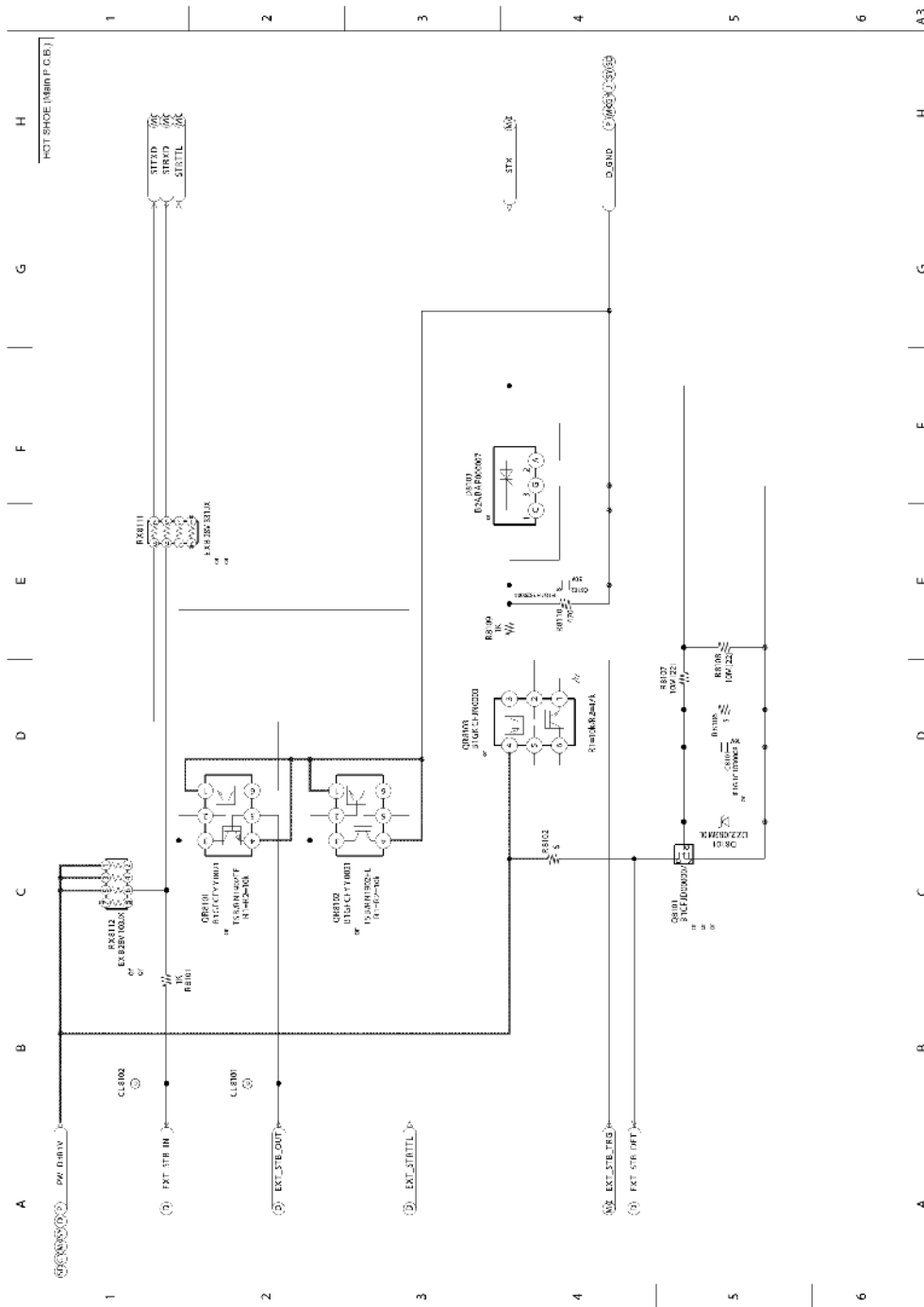

# Model No. : DMC-FZ300/330 Main Connection (MC) (Main P.C.B.)

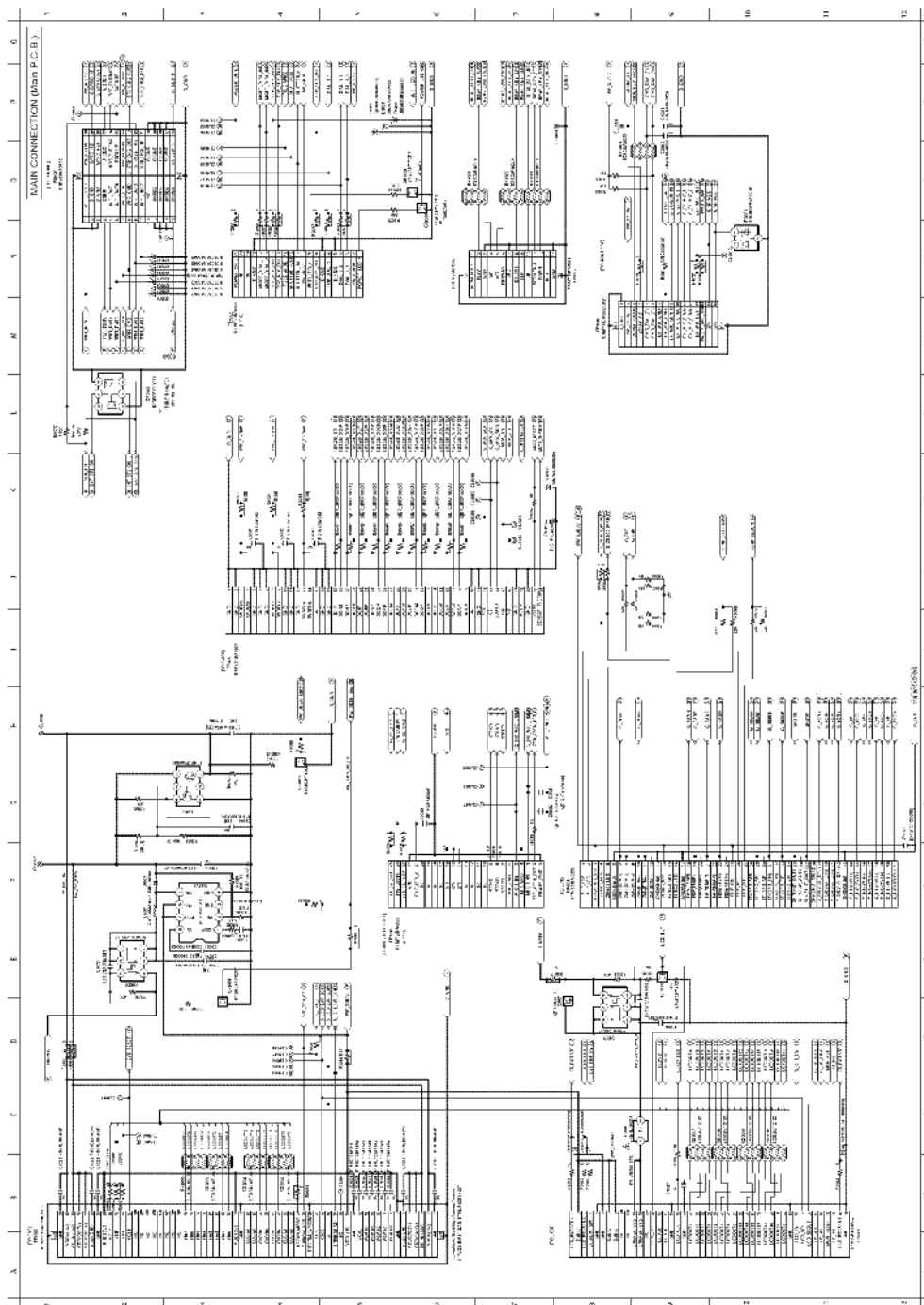

# Model No. : DMC-FZ300/330 System Driver (SY) (Main P.C.B.)

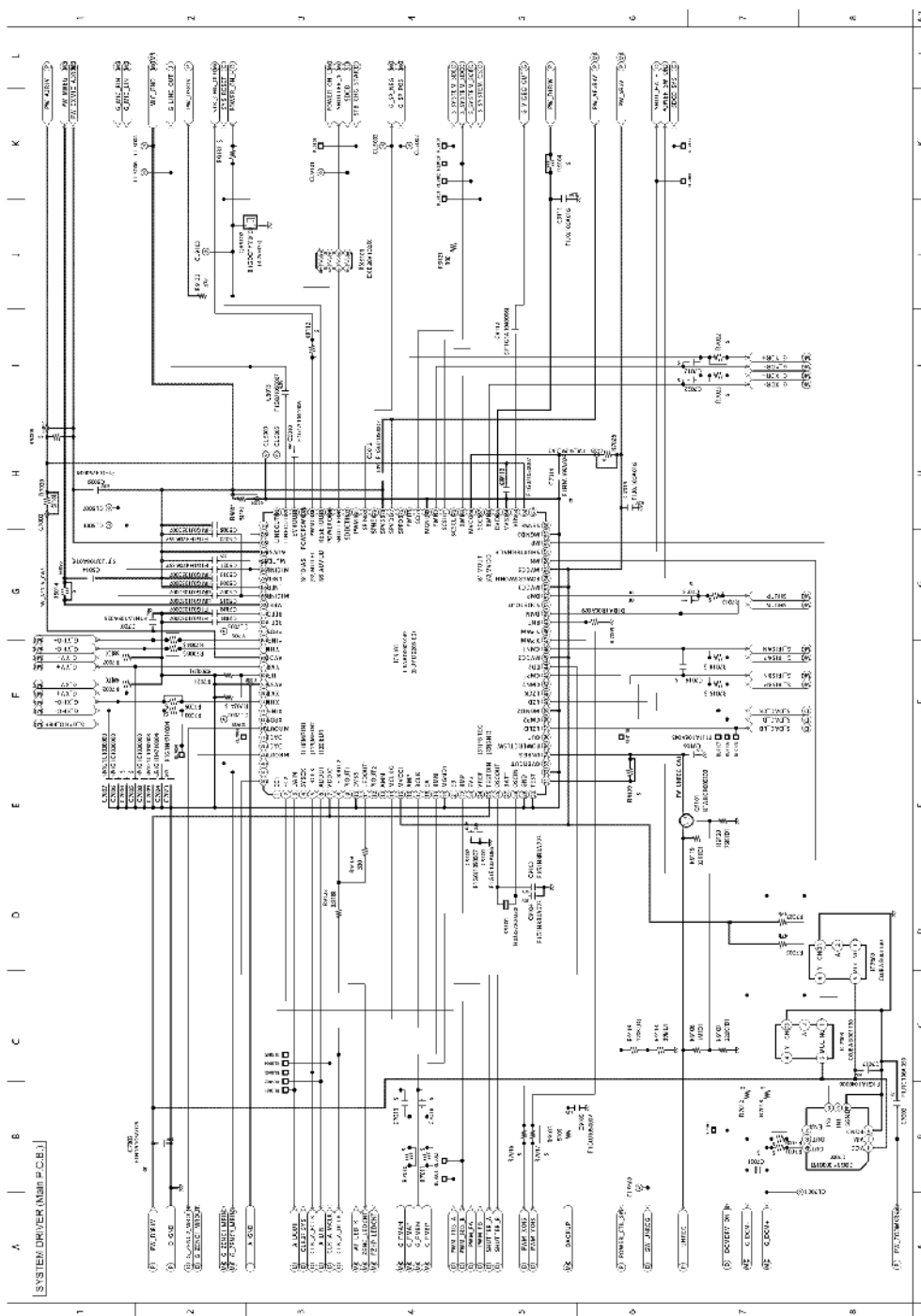

Model No. : DMC-FZ300/330 LCD IF (LCD IF P.C.B.)

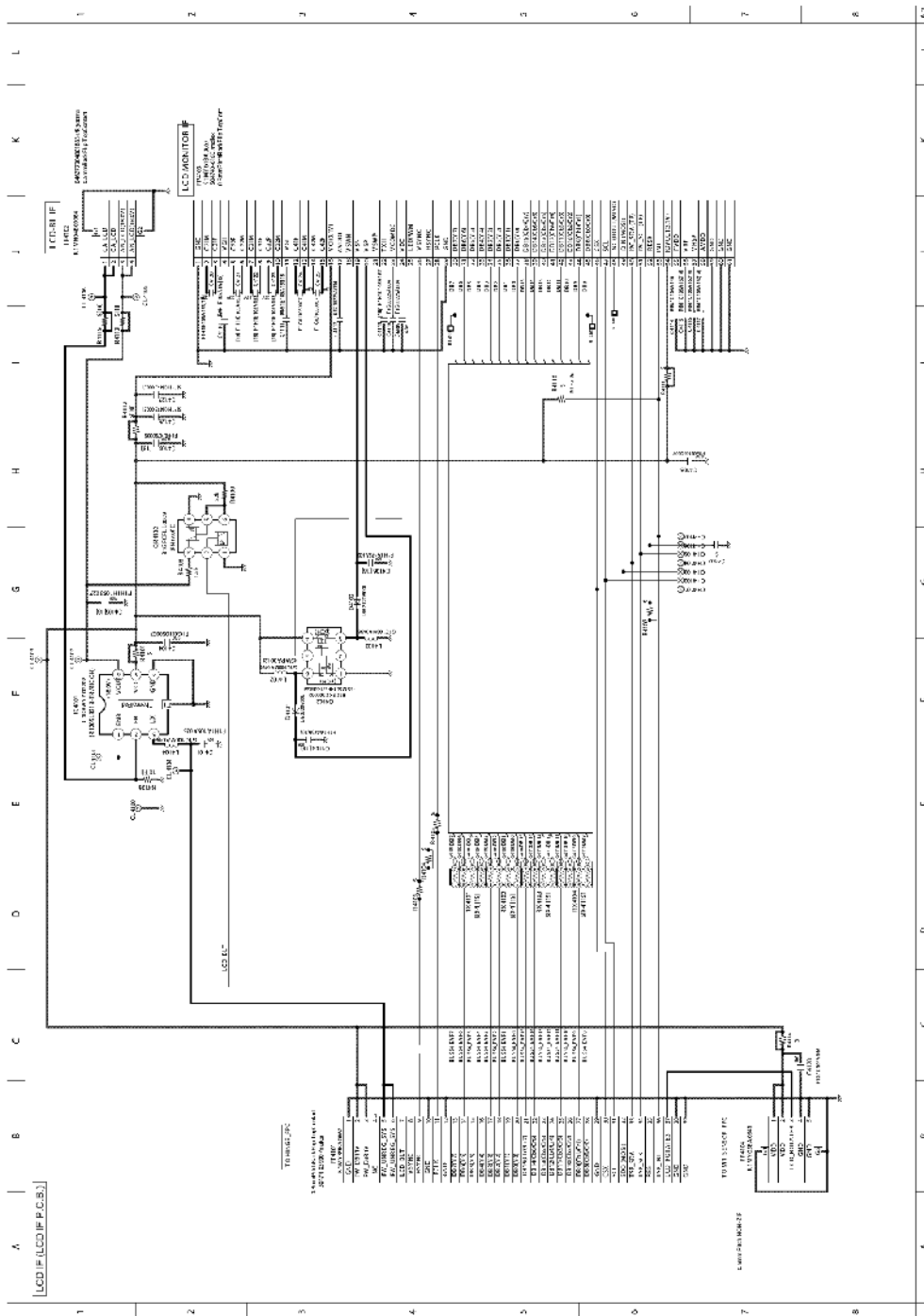

### Model No. : DMC-FZ300/330 Flash (Flash P.C.B.)

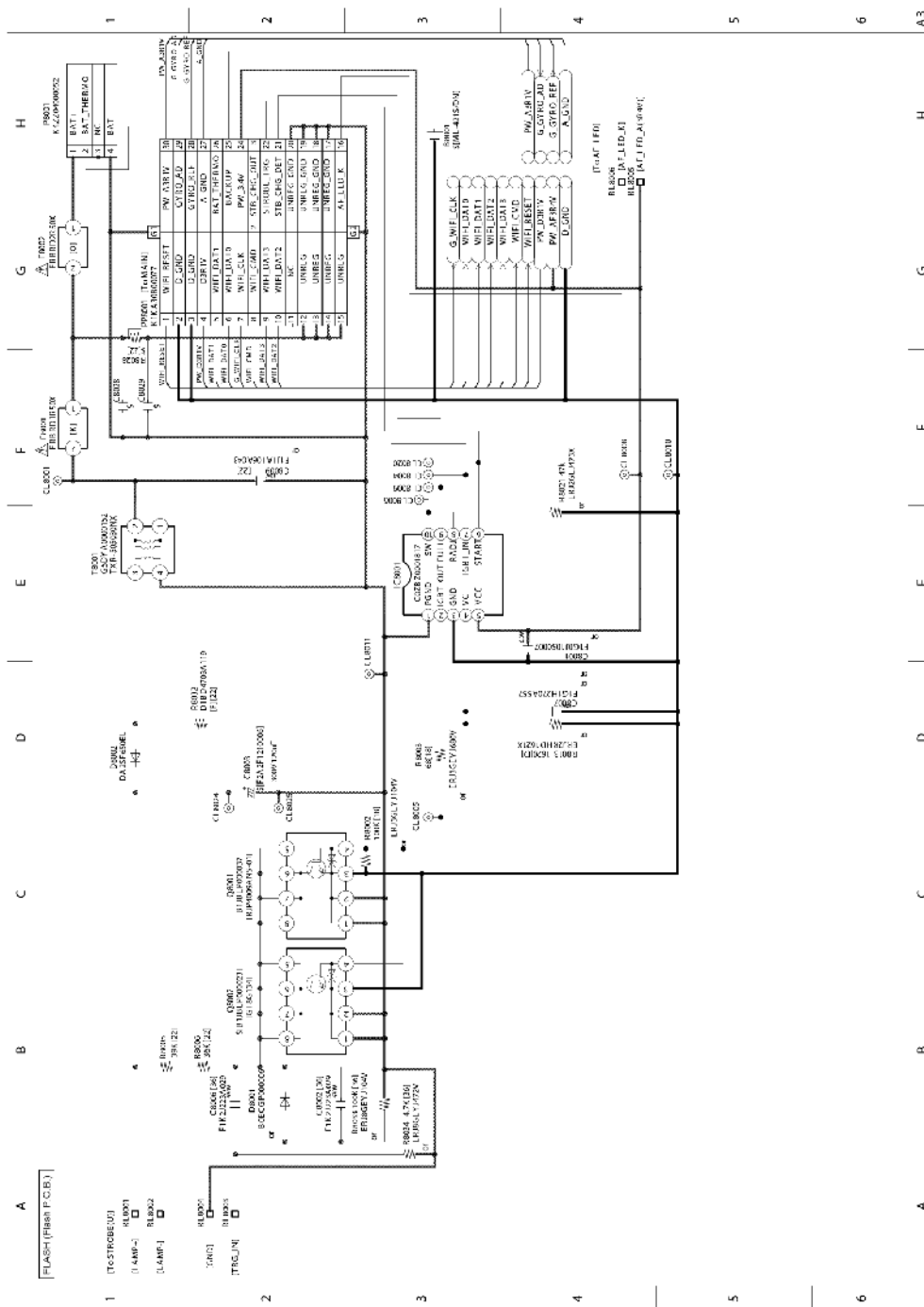

Model No. : DMC-FZ300/330 Wi-Fi (Flash P.C.B.)

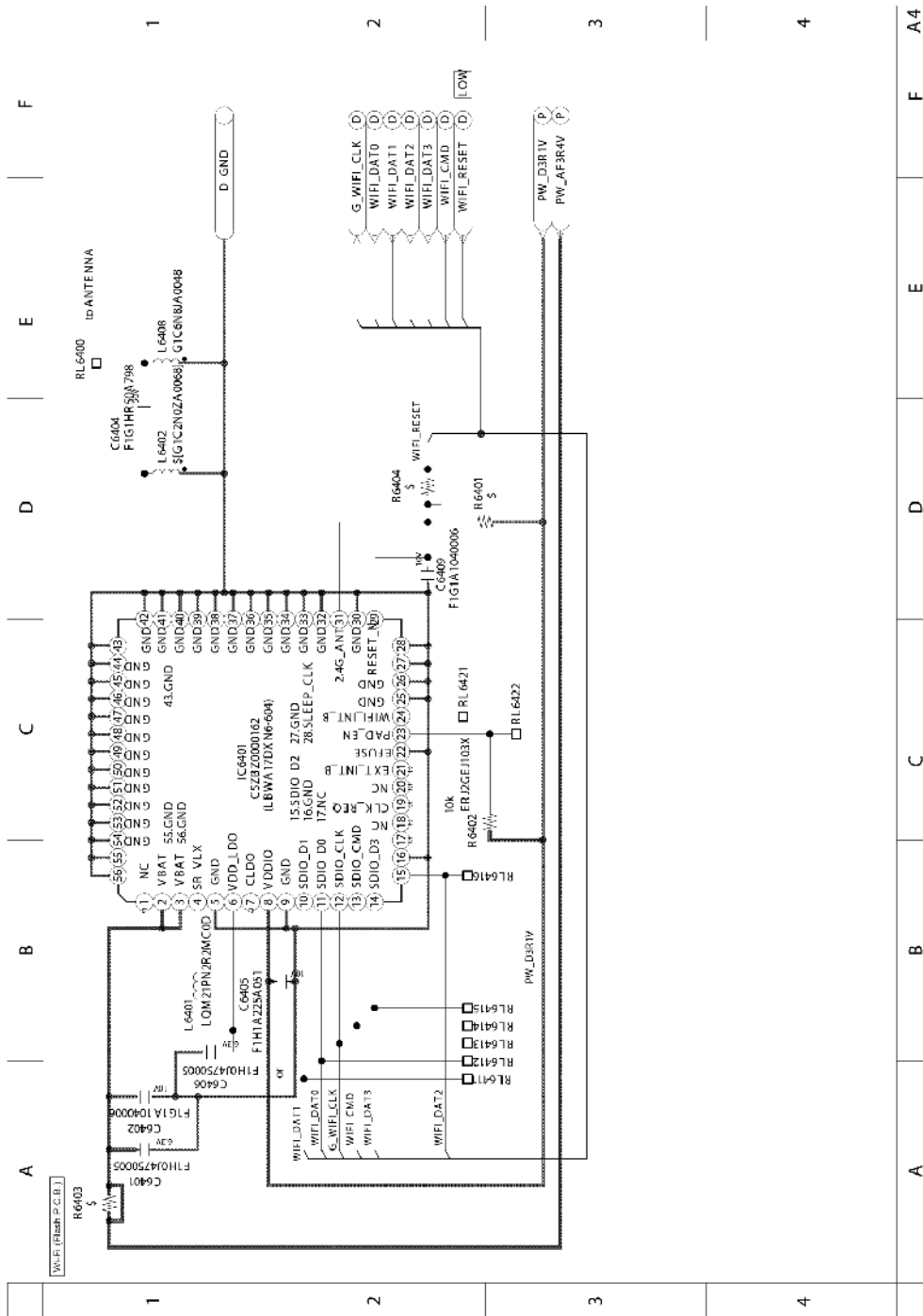

**Model No. : DMC-FZ300/330 EX Gyro (Flash P.C.B.)**

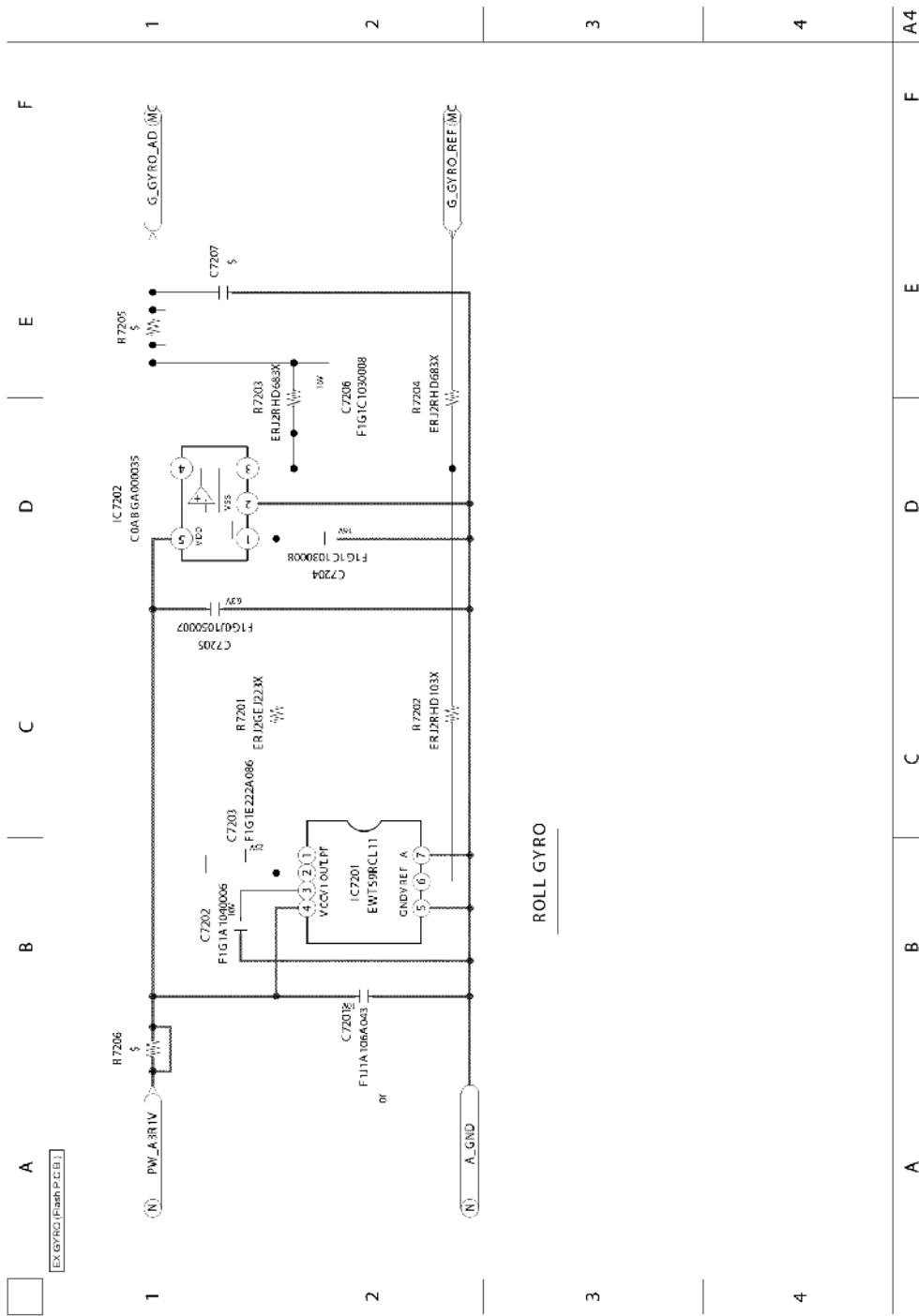

ROLL GYRO



**Model No. : DMC-FZ300/330 MIC Jack (MIC Jack P.C.B.)**

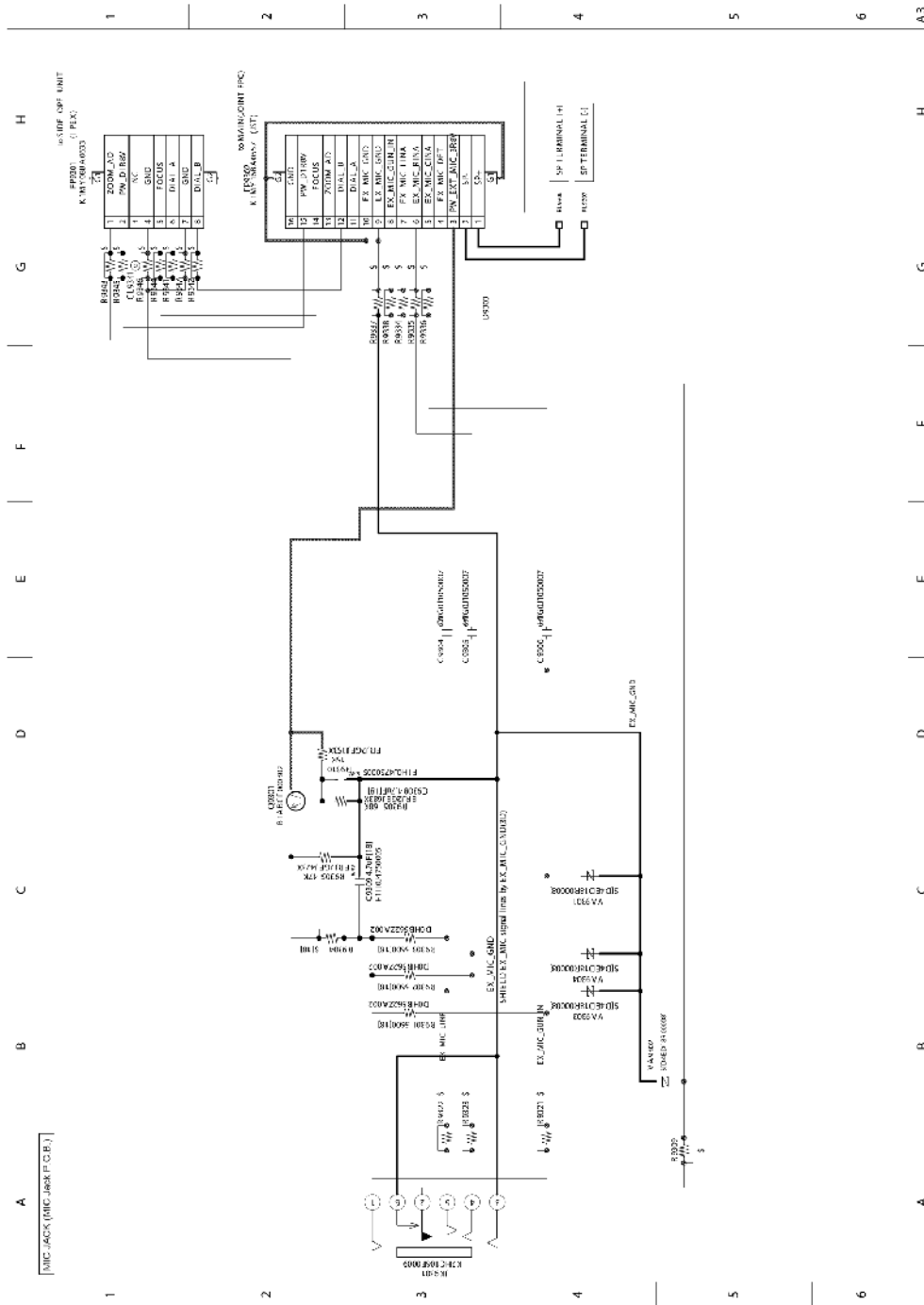

# Model No. : DMC-FZ300/330 Lens Flex (Lens Flex P.C.B.)

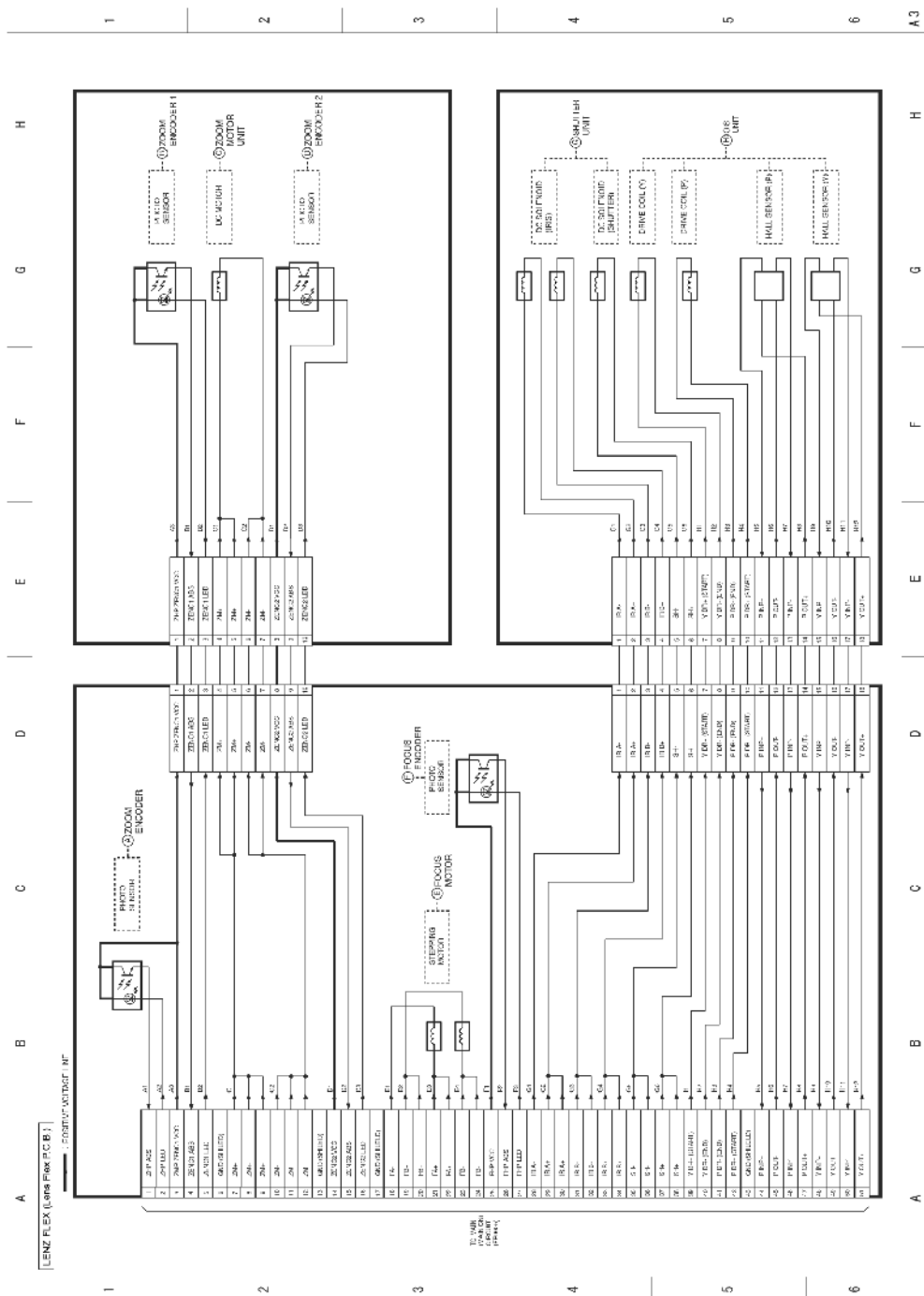

---

**Model No. : DMC-FZ300/330 Main P.C.B. (Component Side)**

---

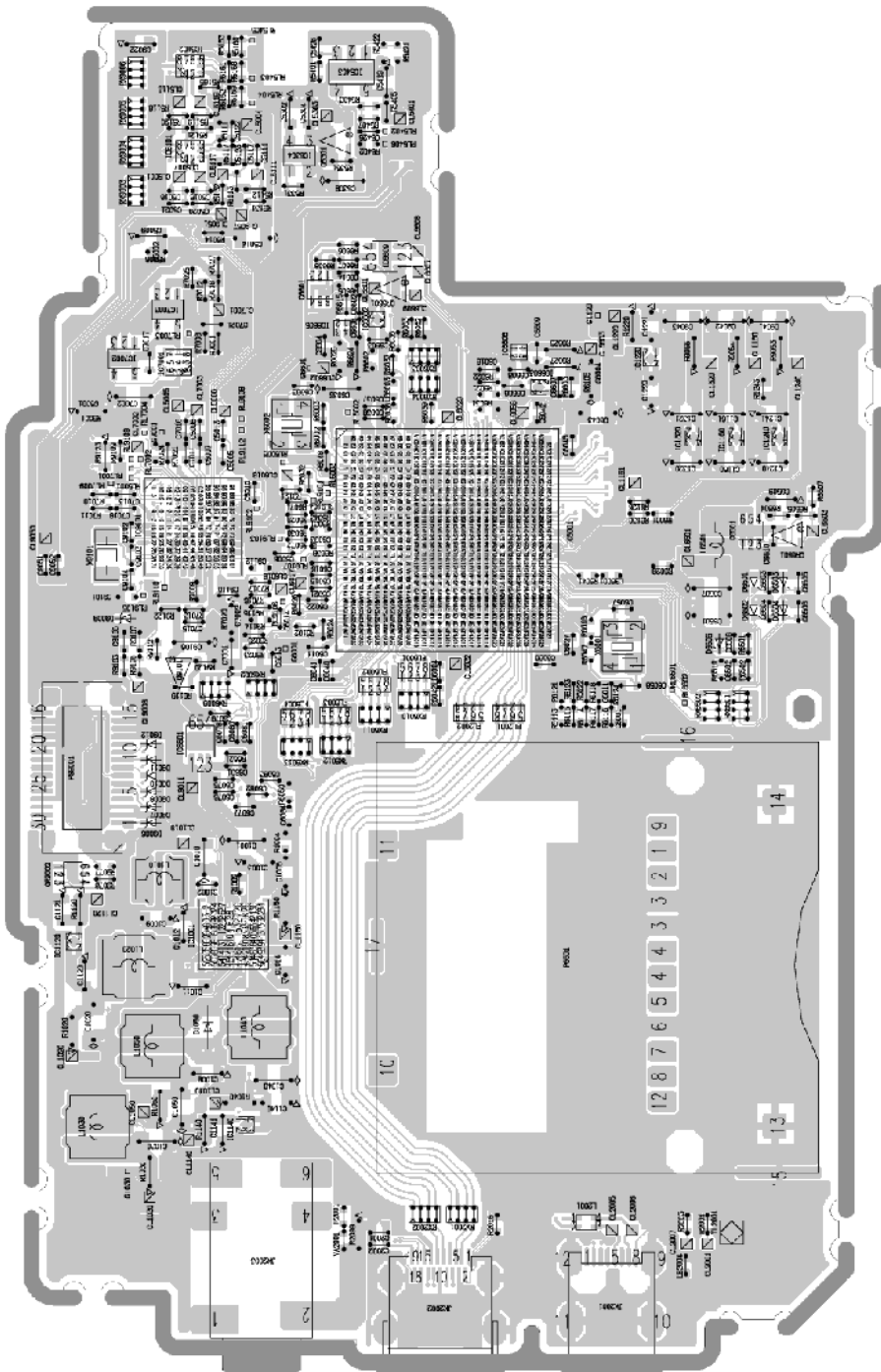

Model No. : DMC-FZ300/330 Main P.C.B. (Foil Side)

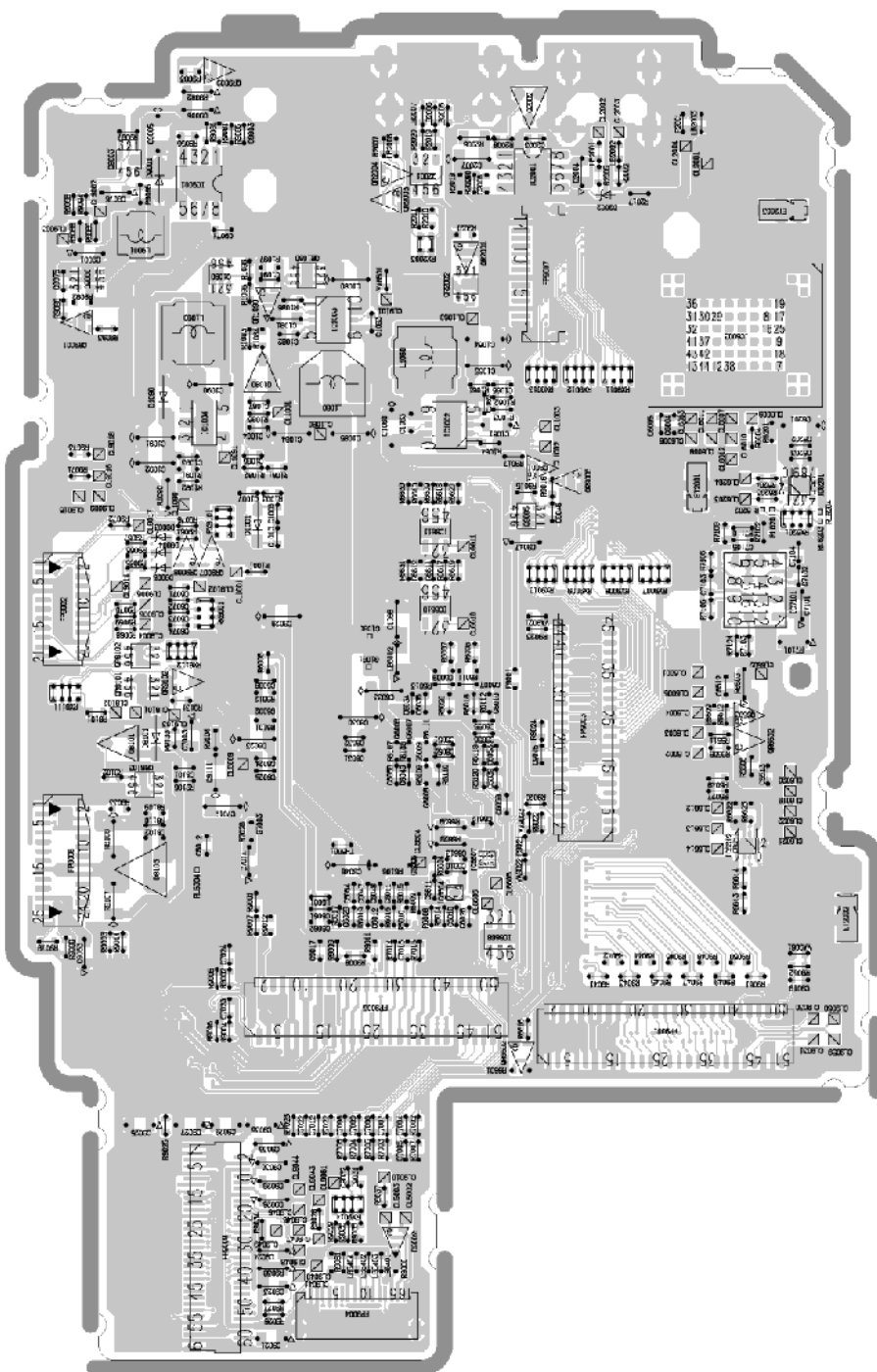

---

**Model No. : DMC-FZ300/330 LCD IF P.C.B. (Component Side)**

---

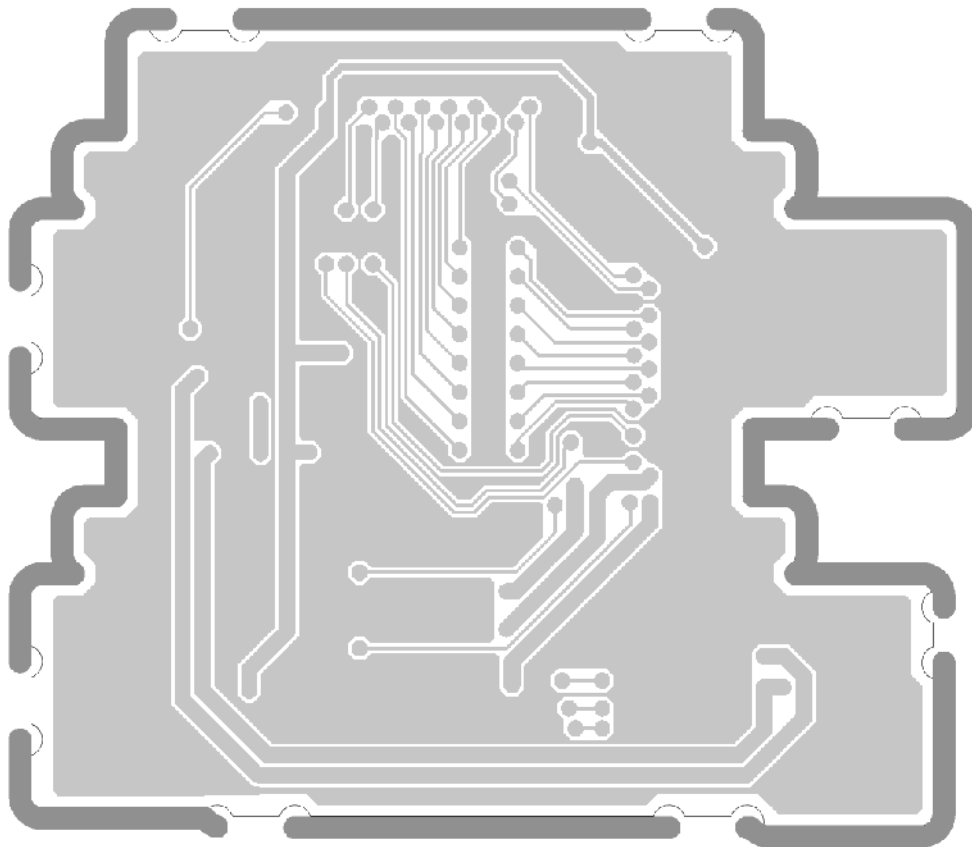

---

**Model No. : DMC-FZ300/330 LCD IF P.C.B. (Foil Side)**

---

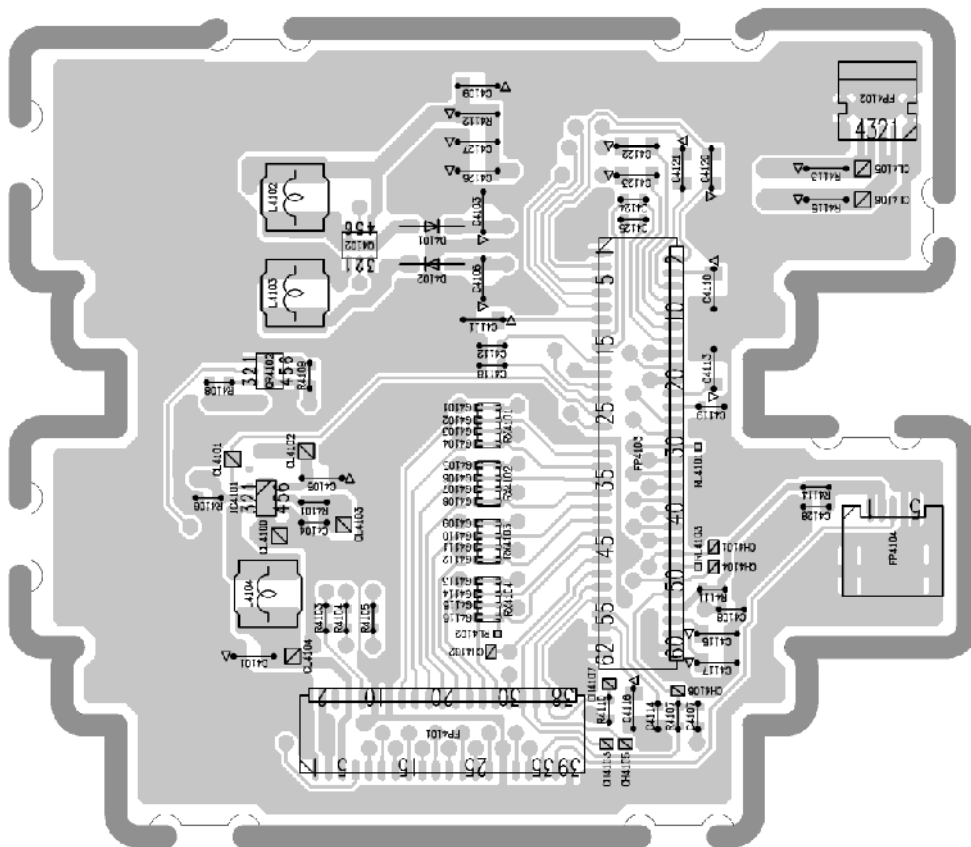

---

**Model No. : DMC-FZ300/330 Flash P.C.B. (Component Side)**

---

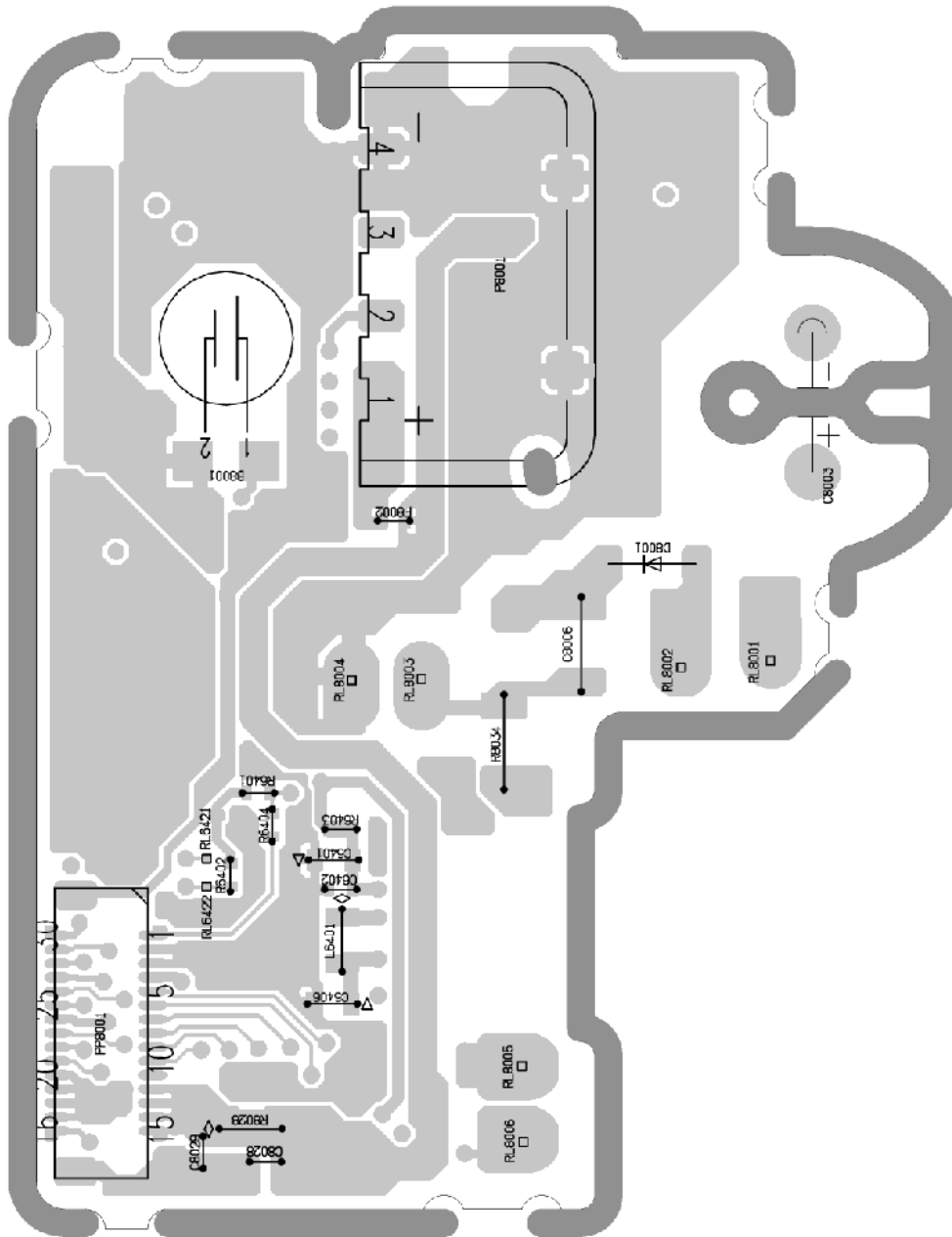

Model No. : DMC-FZ300/330 Flash P.C.B. (Foil Side)

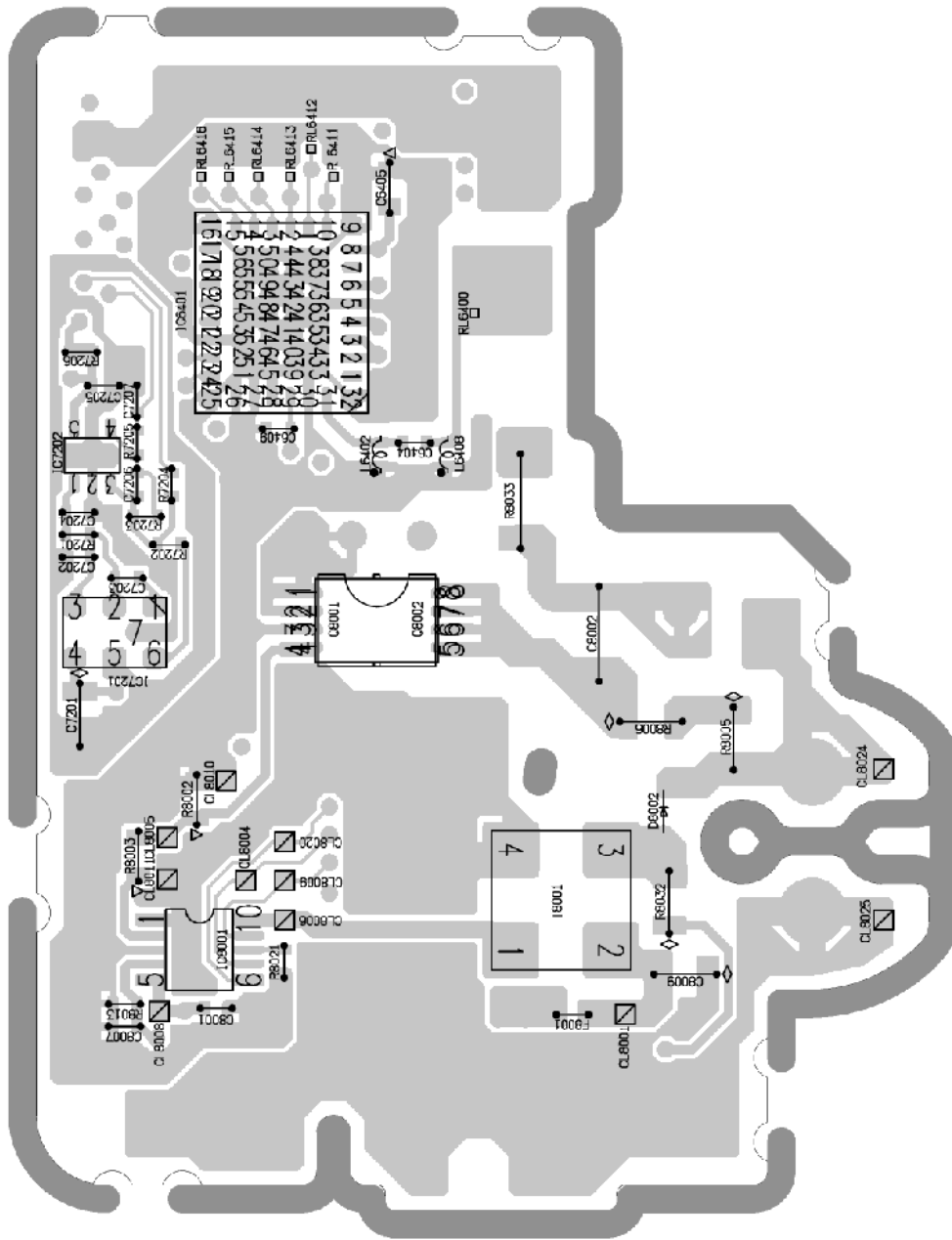



---

**Model No. : DMC-FZ300/330 MIC Jack P.C.B. (Component Side)**

---

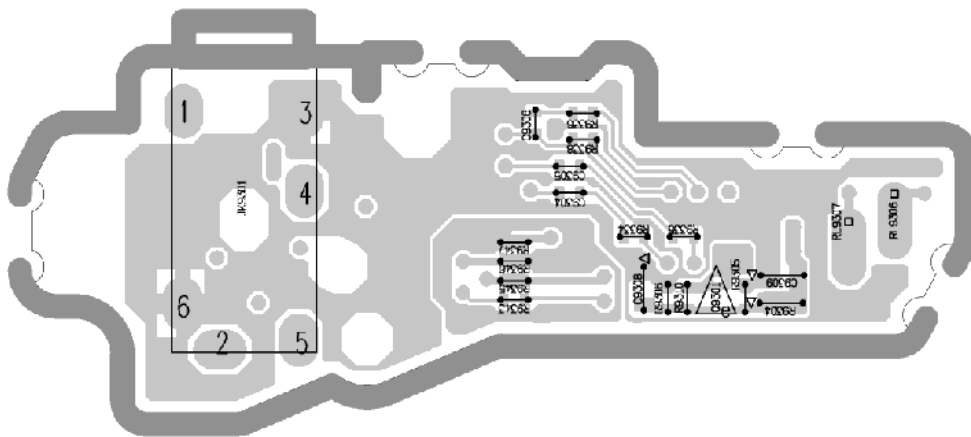

---

**Model No. : DMC-FZ300/330 MIC Jack P.C.B. (Foil Side)**

---

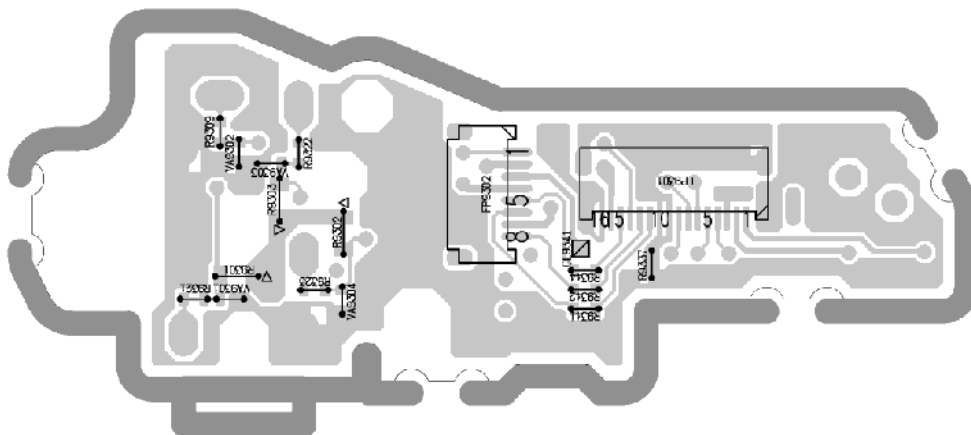

**Model No. : DMC-FZ300/330 Lens Flex P.C.B.**

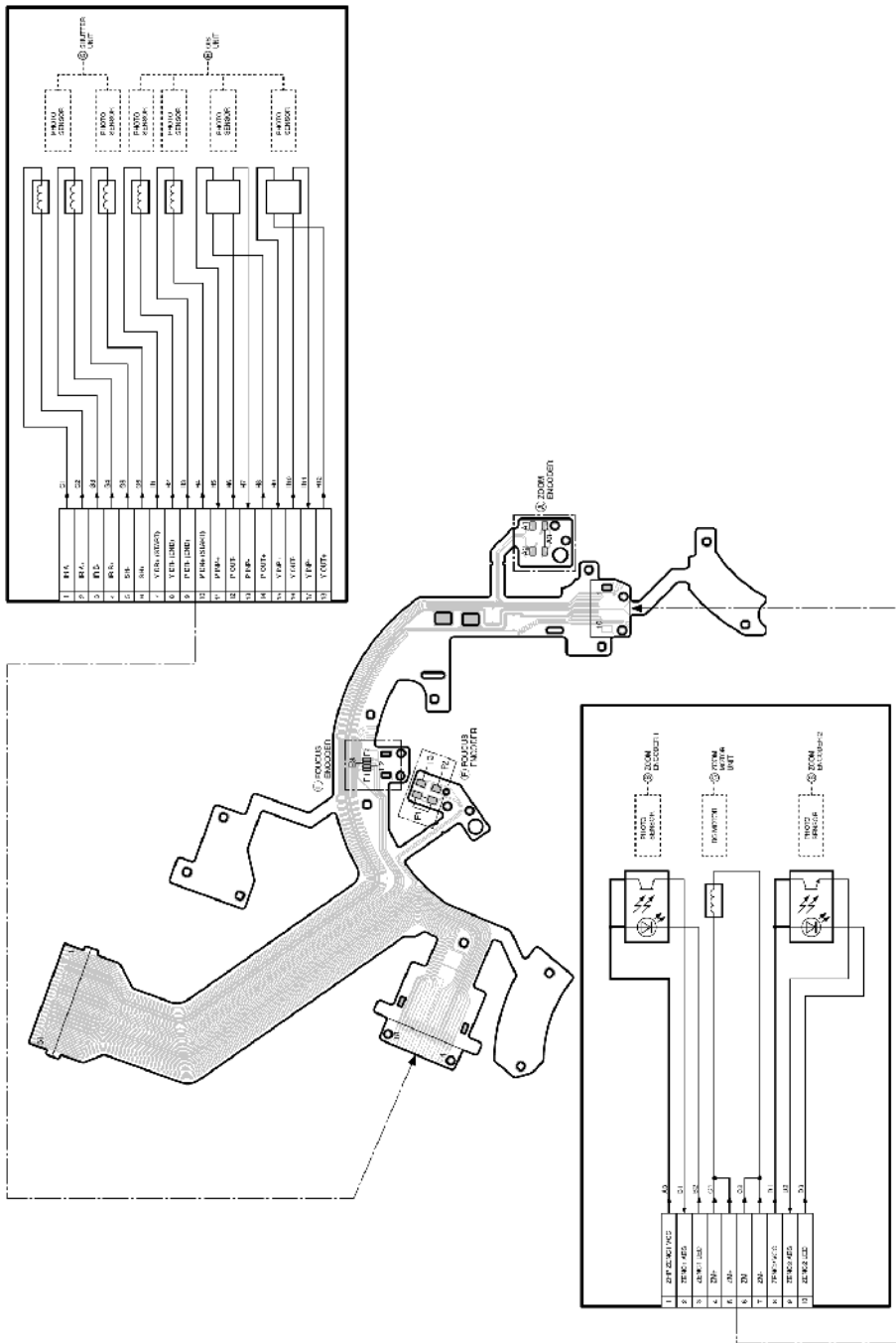

**Model No. : DMC-FZ300/330 Parts List**

Change	Safety	Ref. No.	Part No.	Part Name & Description	Q'ty	Remarks
		C1001	F1J1C106A059	C.CAPACITOR CH 16V 10U	1	
		C1002	F1G1A1040006	C.CAPACITOR CH 10V 0.1U	1	
		C1003	F1H1A4750004	C.CAPACITOR CH 10V 4.7U	1	
		C1004	F1G0J1050007	C.CAPACITOR CH 6.3V 1U	1	
		C1005	F1H1A4750004	C.CAPACITOR CH 10V 4.7U	1	
		C1006	F1G0J1050007	C.CAPACITOR CH 6.3V 1U	1	
		C1007	F1G0J1050007	C.CAPACITOR CH 6.3V 1U	1	
		C1008	F1H1C105A167	C.CAPACITOR CH 16V 1U	1	
		C1009	F1H1C105A167	C.CAPACITOR CH 16V 1U	1	
		C1010	F1J1A106A043	C.CAPACITOR CH 10V 10U	1	
		C1011	F1H1A4750004	C.CAPACITOR CH 10V 4.7U	1	
		C1012	F1H1A4750004	C.CAPACITOR CH 10V 4.7U	1	
		C1013	F1G0J1050007	C.CAPACITOR CH 6.3V 1U	1	
		C1014	F1H1A4750004	C.CAPACITOR CH 10V 4.7U	1	
		C1020	F1J1A106A043	C.CAPACITOR CH 10V 10U	1	
		C1030	F1J1A106A043	C.CAPACITOR CH 10V 10U	1	
		C1040	F1J0J2260004	C.CAPACITOR CH 6.3V 22U	1	
		C1050	F1J1A106A043	C.CAPACITOR CH 10V 10U	1	
		C1060	F1J1A106A043	C.CAPACITOR CH 10V 10U	1	
		C1061	F1H1C105A167	C.CAPACITOR CH 16V 1U	1	
		C1062	F1G1H392A571	C.CAPACITOR CH 50V 3900P	1	
		C1063	F1G1C104A146	C.CAPACITOR CH 16V 0.1U	1	
		C1064	F1J0J2260004	C.CAPACITOR CH 6.3V 22U	1	
		C1065	F1J1A106A043	C.CAPACITOR CH 10V 10U	1	
		C1080	F1J1A106A043	C.CAPACITOR CH 10V 10U	1	
		C1081	F1H1C105A167	C.CAPACITOR CH 16V 1U	1	
		C1082	F1G1H392A571	C.CAPACITOR CH 50V 3900P	1	
		C1083	F1G1C104A146	C.CAPACITOR CH 16V 0.1U	1	
		C1084	F1J0J2260004	C.CAPACITOR CH 6.3V 22U	1	
		C1085	F1J1A106A043	C.CAPACITOR CH 10V 10U	1	
		C1088	F1J1A106A043	C.CAPACITOR CH 10V 10U	1	
		C1090	F1J1C106A059	C.CAPACITOR CH 16V 10U	1	
		C1091	F1J1C106A059	C.CAPACITOR CH 16V 10U	1	
		C1092	F1J1C106A059	C.CAPACITOR CH 16V 10U	1	
		C1093	F1G1H331A541	C.CAPACITOR CH 50V 330P	1	
		C1094	F1G0J1050007	C.CAPACITOR CH 6.3V 1U	1	
		C1120	F1H1C105A167	C.CAPACITOR CH 16V 1U	1	
		C1121	F1H1A225A025	C.CAPACITOR CH 10V 2.2U	1	
		C1140	F1H1C105A167	C.CAPACITOR CH 16V 1U	1	
		C1141	F1H1C105A167	C.CAPACITOR CH 16V 1U	1	
		C1160	F1H1C105A167	C.CAPACITOR CH 16V 1U	1	
		C1161	F1H1C105A167	C.CAPACITOR CH 16V 1U	1	
		C1220	F1H1C105A167	C.CAPACITOR CH 16V 1U	1	
		C1221	F1H1A225A025	C.CAPACITOR CH 10V 2.2U	1	
		C1240	F1H1C105A167	C.CAPACITOR CH 16V 1U	1	
		C1241	F1H1C105A167	C.CAPACITOR CH 16V 1U	1	
		C1320	F1H1C105A167	C.CAPACITOR CH 16V 1U	1	
		C1321	F1H1C105A167	C.CAPACITOR CH 16V 1U	1	
		C2001	F1G1A1040006	C.CAPACITOR CH 10V 0.1U	1	
		C2002	F1G0J1050007	C.CAPACITOR CH 6.3V 1U	1	
		C2003	F1G0J1050007	C.CAPACITOR CH 6.3V 1U	1	
		C2004	F1H1C105A167	C.CAPACITOR CH 16V 1U	1	
		C2007	F1J1A106A043	C.CAPACITOR CH 10V 10U	1	
		C2008	F1G1A1040006	C.CAPACITOR CH 10V 0.1U	1	
		C4101	F1H1A105A025	C.CAPACITOR CH 10V 1U	1	
		C4103	F1H1A4750004	C.CAPACITOR CH 10V 4.7U	1	
		C4104	F1G0J1050007	C.CAPACITOR CH 6.3V 1U	1	
		C4105	F1H1H105B027	C.CAPACITOR CH 50V 1U	1	
		C4106	F1H1A4750004	C.CAPACITOR CH 10V 4.7U	1	
		C4108	F1G0J1050007	C.CAPACITOR CH 6.3V 1U	1	
		C4109	F1H0J4750005	C.CAPACITOR CH 6.3V 4.7U	1	

		C4110	F1H1H105B027	C.CAPACITOR CH 50V 1U	1	
--	--	-------	--------------	-----------------------	---	--

**Model No. : DMC-FZ300/330 Parts List**

Change	Safety	Ref. No.	Part No.	Part Name & Description	Q'ty	Remarks
		C4111	F1H1H105B027	C.CAPACITOR CH 50V 1U	1	
		C4112	F1G0J225A034	C.CAPACITOR CH 6.3V 2.2U	1	
		C4113	F1H1C105A167	C.CAPACITOR CH 16V 1U	1	
		C4114	F1G1C104A146	C.CAPACITOR CH 16V 0.1U	1	
		C4115	F1H1C105A167	C.CAPACITOR CH 16V 1U	1	
		C4116	F1H1C105A167	C.CAPACITOR CH 16V 1U	1	
		C4117	F1H1C105A167	C.CAPACITOR CH 16V 1U	1	
		C4118	F1G0J225A034	C.CAPACITOR CH 6.3V 2.2U	1	
		C4119	F1G0J225A034	C.CAPACITOR CH 6.3V 2.2U	1	
		C4120	F1H1H105B027	C.CAPACITOR CH 50V 1U	1	
		C4121	F1H1H105B027	C.CAPACITOR CH 50V 1U	1	
		C4122	F1H1H105B027	C.CAPACITOR CH 50V 1U	1	
		C4123	F1H1H105B027	C.CAPACITOR CH 50V 1U	1	
		C4124	F1G0J1050007	C.CAPACITOR CH 6.3V 1U	1	
		C4125	F1G0J1050007	C.CAPACITOR CH 6.3V 1U	1	
		C4128	F1G1C104A146	C.CAPACITOR CH 16V 0.1U	1	
		C5005	F1G0J1050007	C.CAPACITOR CH 6.3V 1U	1	
		C5006	F1G0J1050007	C.CAPACITOR CH 6.3V 1U	1	
		C5007	F1G0J1050007	C.CAPACITOR CH 6.3V 1U	1	
		C5009	F1H0J4750005	C.CAPACITOR CH 6.3V 4.7U	1	
		C5010	F1G1A1040006	C.CAPACITOR CH 10V 0.1U	1	
		C5012	F1G0J1050007	C.CAPACITOR CH 6.3V 1U	1	
		C5013	F1G0J1050007	C.CAPACITOR CH 6.3V 1U	1	
		C5015	F1G0J1050007	C.CAPACITOR CH 6.3V 1U	1	
		C5016	F1G0J1050007	C.CAPACITOR CH 6.3V 1U	1	
		C5020	F1G1H470A834	C.CAPACITOR CH 50V 47P	1	
		C5021	F1G1H470A834	C.CAPACITOR CH 50V 47P	1	
		C5111	F1G1A473A069	C.CAPACITOR CH 10V 0.047U	1	
		C5117	F1G1A473A069	C.CAPACITOR CH 10V 0.047U	1	
		C5122	F1G1H4710004	C.CAPACITOR CH 50V 470P	1	
		C5123	F1G1H4710004	C.CAPACITOR CH 50V 470P	1	
		C5302	F1H1C105A167	C.CAPACITOR CH 16V 1U	1	
		C5304	F1H1C105A167	C.CAPACITOR CH 16V 1U	1	
		C5308	F1J0J2260004	C.CAPACITOR CH 6.3V 22U	1	
		C5419	F1H1E104A029	C.CAPACITOR CH 25V 0.1U	1	
		C5425	F1G1H101A834	C.CAPACITOR CH 50V 100P	1	
		C6004	F1G1A1040006	C.CAPACITOR CH 10V 0.1U	1	
		C6005	F1G1C1030008	C.CAPACITOR CH 16V 0.01U	1	
		C6006	F1G1C1030008	C.CAPACITOR CH 16V 0.01U	1	
		C6007	F1G1A1040006	C.CAPACITOR CH 10V 0.1U	1	
		C6008	F1G1A1040006	C.CAPACITOR CH 10V 0.1U	1	
		C6009	F1G1A1040006	C.CAPACITOR CH 10V 0.1U	1	
		C6010	F1G1A1040006	C.CAPACITOR CH 10V 0.1U	1	
		C6011	F1G1A1040006	C.CAPACITOR CH 10V 0.1U	1	
		C6012	F1G1A1040006	C.CAPACITOR CH 10V 0.1U	1	
		C6013	F1G1A1040006	C.CAPACITOR CH 10V 0.1U	1	
		C6014	F1G1A1040006	C.CAPACITOR CH 10V 0.1U	1	
		C6018	F1G1E102A086	C.CAPACITOR CH 25V 1000P	1	
		C6021	F1G1E102A086	C.CAPACITOR CH 25V 1000P	1	
		C6022	F1G1E102A086	C.CAPACITOR CH 25V 1000P	1	
		C6023	F1J0J106A016	C.CAPACITOR CH 6.3V 10U	1	
		C6024	F1G1A1040006	C.CAPACITOR CH 10V 0.1U	1	
		C6025	F1G1C1030008	C.CAPACITOR CH 16V 0.01U	1	
		C6026	F1G1C1030008	C.CAPACITOR CH 16V 0.01U	1	
		C6027	F1G1C1030008	C.CAPACITOR CH 16V 0.01U	1	
		C6028	F1G1C1030008	C.CAPACITOR CH 16V 0.01U	1	
		C6029	F1J1C106A059	C.CAPACITOR CH 16V 10U	1	
		C6030	F1J0J106A016	C.CAPACITOR CH 6.3V 10U	1	
		C6031	F1G1A1040006	C.CAPACITOR CH 10V 0.1U	1	
		C6032	F1G1C1030008	C.CAPACITOR CH 16V 0.01U	1	
		C6033	F1J0J106A016	C.CAPACITOR CH 6.3V 10U	1	

		C6034	F1G1A1040006	C.CAPACITOR CH 10V 0.1U	1	
--	--	-------	--------------	-------------------------	---	--

**Model No. : DMC-FZ300/330 Parts List**

Change	Safety	Ref. No.	Part No.	Part Name & Description	Q'ty	Remarks
		C6035	F1G1C1030008	C.CAPACITOR CH 16V 0.01U	1	
		C6036	F1J0J106A020	C.CAPACITOR CH 6.3V 10U	1	
		C6037	F1G1A1040006	C.CAPACITOR CH 10V 0.1U	1	
		C6038	F1G1C1030008	C.CAPACITOR CH 16V 0.01U	1	
		C6039	F1G1C1030008	C.CAPACITOR CH 16V 0.01U	1	
		C6040	F1G1A1040006	C.CAPACITOR CH 10V 0.1U	1	
		C6041	F1G1C1030008	C.CAPACITOR CH 16V 0.01U	1	
		C6042	F1G1C1030008	C.CAPACITOR CH 16V 0.01U	1	
		C6044	F1G1A1040006	C.CAPACITOR CH 10V 0.1U	1	
		C6045	F1G1C1030008	C.CAPACITOR CH 16V 0.01U	1	
		C6046	F1J0J106A016	C.CAPACITOR CH 6.3V 10U	1	
		C6047	F1G1A1040006	C.CAPACITOR CH 10V 0.1U	1	
		C6048	F1G1C1030008	C.CAPACITOR CH 16V 0.01U	1	
		C6049	F1G1A1040006	C.CAPACITOR CH 10V 0.1U	1	
		C6050	F1G1C1030008	C.CAPACITOR CH 16V 0.01U	1	
		C6051	F1G1A1040006	C.CAPACITOR CH 10V 0.1U	1	
		C6052	F1G1C1030008	C.CAPACITOR CH 16V 0.01U	1	
		C6053	F1G1C1030008	C.CAPACITOR CH 16V 0.01U	1	
		C6054	F1G1C1030008	C.CAPACITOR CH 16V 0.01U	1	
		C6055	F1G1A1040006	C.CAPACITOR CH 10V 0.1U	1	
		C6056	F1G1C1030008	C.CAPACITOR CH 16V 0.01U	1	
		C6057	F1G1H9R0A833	C.CAPACITOR CH 50V 9P	1	
		C6058	F1G1H9R0A833	C.CAPACITOR CH 50V 9P	1	
		C6060	F1G1C1030008	C.CAPACITOR CH 16V 0.01U	1	
		C6061	F1G0J1050007	C.CAPACITOR CH 6.3V 1U	1	
		C6062	F1G1C1030008	C.CAPACITOR CH 16V 0.01U	1	
		C6071	F1G1C1030008	C.CAPACITOR CH 16V 0.01U	1	
		C6072	F1G1C1030008	C.CAPACITOR CH 16V 0.01U	1	
		C6073	F1G1C1030008	C.CAPACITOR CH 16V 0.01U	1	
		C6075	F1G1C1030008	C.CAPACITOR CH 16V 0.01U	1	
		C6076	F1G1C1030008	C.CAPACITOR CH 16V 0.01U	1	
		C6077	F1G1C1030008	C.CAPACITOR CH 16V 0.01U	1	
		C6078	F1G1C1030008	C.CAPACITOR CH 16V 0.01U	1	
		C6079	F1G1C1030008	C.CAPACITOR CH 16V 0.01U	1	
		C6080	F1G1C1030008	C.CAPACITOR CH 16V 0.01U	1	
		C6081	F1G1C1030008	C.CAPACITOR CH 16V 0.01U	1	
		C6082	F1G1C1030008	C.CAPACITOR CH 16V 0.01U	1	
		C6083	F1G1C1030008	C.CAPACITOR CH 16V 0.01U	1	
		C6201	F1J1A106A043	C.CAPACITOR CH 10V 10U	1	
		C6203	F1G1A1040006	C.CAPACITOR CH 10V 0.1U	1	
		C6507	F1J1A106A043	C.CAPACITOR CH 10V 10U	1	
		C6509	F1H0J4750005	C.CAPACITOR CH 6.3V 4.7U	1	
		C6510	F1G1C1030008	C.CAPACITOR CH 16V 0.01U	1	
		C6512	F1G0J1050007	C.CAPACITOR CH 6.3V 1U	1	
		C6601	F1G0J4740003	C.CAPACITOR CH 6.3V 0.47U	1	
		C6602	F1G0J4740003	C.CAPACITOR CH 6.3V 0.47U	1	
		C6603	F1G0J4740003	C.CAPACITOR CH 6.3V 0.47U	1	
		C6604	F1G0J1050007	C.CAPACITOR CH 6.3V 1U	1	
		C6605	F1G1A1040006	C.CAPACITOR CH 10V 0.1U	1	
		C6606	F1G0J4740003	C.CAPACITOR CH 6.3V 0.47U	1	
		C6607	F1G0J4740003	C.CAPACITOR CH 6.3V 0.47U	1	
		C6608	F1G0J1050007	C.CAPACITOR CH 6.3V 1U	1	
		C6609	F1G1A1040006	C.CAPACITOR CH 10V 0.1U	1	
		C6610	F1G0J4740003	C.CAPACITOR CH 6.3V 0.47U	1	
		C6611	F1G0J4740003	C.CAPACITOR CH 6.3V 0.47U	1	
		C6612	F1G1A1040006	C.CAPACITOR CH 10V 0.1U	1	
		C6613	F1G1A1040006	C.CAPACITOR CH 10V 0.1U	1	
		C6614	F1G1A1040006	C.CAPACITOR CH 10V 0.1U	1	
		C7001	F1H1C105A167	C.CAPACITOR CH 16V 1U	1	
		C7002	F1J1C106A059	C.CAPACITOR CH 16V 10U	1	
		C7003	F1H1C105A167	C.CAPACITOR CH 16V 1U	1	





		C7006	F1G1C1030008	C.CAPACITOR CH 16V 0.01U	1	
--	--	-------	--------------	--------------------------	---	--

**Model No. : DMC-FZ300/330 Parts List**

Change	Safety	Ref. No.	Part No.	Part Name & Description	Q'ty	Remarks
		C7007	F1G1C1030008	C.CAPACITOR CH 16V 0.01U	1	
		C7008	F1G1C1030008	C.CAPACITOR CH 16V 0.01U	1	
		C7009	F1G1C1030008	C.CAPACITOR CH 16V 0.01U	1	
		C7010	F1G0J1050007	C.CAPACITOR CH 6.3V 1U	1	
		C7011	F1G0J1050007	C.CAPACITOR CH 6.3V 1U	1	
		C7014	F1H1C105A167	C.CAPACITOR CH 16V 1U	1	
		C7017	F1G1A1040006	C.CAPACITOR CH 10V 0.1U	1	
		C7019	F1J0J106A016	C.CAPACITOR CH 6.3V 10U	1	
		C7023	F1G1H4710004	C.CAPACITOR CH 50V 470P	1	
		C7024	F1G1H4710004	C.CAPACITOR CH 50V 470P	1	
		C7101	F1H0J4750005	C.CAPACITOR CH 6.3V 4.7U	1	
		C7102	F1G1A1040006	C.CAPACITOR CH 10V 0.1U	1	
		C7103	F1G1A1040006	C.CAPACITOR CH 10V 0.1U	1	
		C7104	F1G1A1040006	C.CAPACITOR CH 10V 0.1U	1	
		C7105	F1G1A1040006	C.CAPACITOR CH 10V 0.1U	1	
		C8101	F1G1C1030008	C.CAPACITOR CH 16V 0.01U	1	
		C8102	F1G1H3320004	C.CAPACITOR CH 50V 3300P	1	
		C9001	F1H1C105A167	C.CAPACITOR CH 16V 1U	1	
		C9003	F1G1H3320004	C.CAPACITOR CH 50V 3300P	1	
		C9005	F1J1C475A059	C.CAPACITOR CH 16V 4.7U	1	
		C9019	F1G1A1040006	C.CAPACITOR CH 10V 0.1U	1	
		C9021	F1H1C104A041	C.CAPACITOR CH 16V 0.1U	1	
		C9022	F1H1C224A074	C.CAPACITOR CH 16V 0.22U	1	
		C9023	F1H1C104A041	C.CAPACITOR CH 16V 0.1U	1	
		C9024	F1H1C104A041	C.CAPACITOR CH 16V 0.1U	1	
		C9025	F1H1C105A167	C.CAPACITOR CH 16V 1U	1	
		C9026	F1H1C105A167	C.CAPACITOR CH 16V 1U	1	
		C9027	F1H1C105A167	C.CAPACITOR CH 16V 1U	1	
		C9028	F1H1C105A167	C.CAPACITOR CH 16V 1U	1	
		C9029	F1H1C105A167	C.CAPACITOR CH 16V 1U	1	
		C9030	F1H1C105A167	C.CAPACITOR CH 16V 1U	1	
		C9031	F1G1A1040006	C.CAPACITOR CH 10V 0.1U	1	
		C9032	F1G1A1040006	C.CAPACITOR CH 10V 0.1U	1	
		C9035	F1H1C224A074	C.CAPACITOR CH 16V 0.22U	1	
		C9036	F1H1C104A041	C.CAPACITOR CH 16V 0.1U	1	
		C9041	F1J1A106A043	C.CAPACITOR CH 10V 10U	1	
		C9042	F1J1A106A043	C.CAPACITOR CH 10V 10U	1	
		C9043	F1J1A106A043	C.CAPACITOR CH 10V 10U	1	
		C9047	F1H1C105A167	C.CAPACITOR CH 16V 1U	1	
		C9074	F1G1C1030008	C.CAPACITOR CH 16V 0.01U	1	
		C9076	F1H1C104A041	C.CAPACITOR CH 16V 0.1U	1	
		C9101	F1G1E102A086	C.CAPACITOR CH 25V 1000P	1	
		C9102	F1G0J1050007	C.CAPACITOR CH 6.3V 1U	1	
		C9103	F1G1H8R0A723	C.CAPACITOR CH 50V 8P	1	
		C9104	F1G1H8R0A723	C.CAPACITOR CH 50V 8P	1	
		C9105	F1G0J1050007	C.CAPACITOR CH 6.3V 1U	1	
		C9106	F1J1A106A043	C.CAPACITOR CH 10V 10U	1	
		C9110	F1G0J1050007	C.CAPACITOR CH 6.3V 1U	1	
		C9111	F1J0J106A016	C.CAPACITOR CH 6.3V 10U	1	
		C9304	F1G0J1050007	C.CAPACITOR CH 6.3V 1U	1	
		C9305	F1G0J1050007	C.CAPACITOR CH 6.3V 1U	1	
		C9306	F1G0J1050007	C.CAPACITOR CH 6.3V 1U	1	
		C9308	F1H0J4750005	C.CAPACITOR CH 6.3V 4.7U	1	
		C9309	F1H0J4750005	C.CAPACITOR CH 6.3V 4.7U	1	
		D1001	DB2J20800L	DIODE	1	E.S.D.
		D1050	B0ACRC000001	DIODE	1	E.S.D.
		D1090	B0ACRC000001	DIODE	1	E.S.D.
		D4101	DB2J20800L	DIODE	1	E.S.D.
		D4102	DB2J20800L	DIODE	1	E.S.D.
		D8101	DZ2J082M0L	DIODE	1	E.S.D.
		D8103	B2ABAP000007	DIODE	1	E.S.D.

		D9001	DB2J20800L	DIODE	1	E.S.D.
--	--	-------	------------	-------	---	--------

**Model No. : DMC-FZ300/330 Parts List**

Change	Safety	Ref. No.	Part No.	Part Name & Description	Q'ty	Remarks
		D9006	B0BC6R8A0663	DIODE	1	E.S.D.
		D9007	B0BC6R8A0663	DIODE	1	E.S.D.
		D9008	B0BC6R8A0663	DIODE	1	E.S.D.
		D9010	B0BC6R8A0663	DIODE	1	E.S.D.
		D9011	B0BC6R8A0663	DIODE	1	E.S.D.
		D9012	B0BC6R8A0663	DIODE	1	E.S.D.
		ET2001	K4ZZ01000300	EARTH TERMINAL	1	
		ET2002	K4ZZ01000300	EARTH TERMINAL	1	
		F2001	ERBRD1R50X	FUSE 32V 1.5A	1	
		F9001	ERBRD0R31X	FUSE 32V 0.315A	1	
		FL2001	EXC28CH900U	FILTER	1	
		FL2002	EXC28CH900U	FILTER	1	
		FL6001	J0JAD0000028	FILTER	1	
		FL6002	J0JAD0000028	FILTER	1	
		FL6003	J0JAD0000028	FILTER	1	
		FL6004	J0JAD0000028	FILTER	1	
		FP4101	K1MY39BA0667	CONNECTOR 39P	1	
		FP4102	K1MN04B00084	CONNECTOR 4P	1	
		FP4103	K1MY61BA0667	CONNECTOR 61P	1	
		FP4104	K1MY05BA0641	CONNECTOR 5P	1	
		FP9001	K1MY51BA0667	CONNECTOR 51P	1	
		FP9002	K1MY21BA0585	CONNECTOR 21P	1	
		FP9003	K1MY45BA0667	CONNECTOR 45P	1	
		FP9004	K1MY16BA0557	CONNECTOR 16P	1	
		FP9005	K1MY51BA0556	CONNECTOR 51P	1	
		FP9006	K1MY25BA0585	CONNECTOR 25P	1	
		FP9007	K1MY14BA0633	CONNECTOR 14P	1	
		FP9009	K1MY61AA0288	CONNECTOR 61P	1	
		FP9301	K1MY16BA0557	CONNECTOR 16P	1	
		FP9302	K1MY08BA0633	CONNECTOR 8P	1	
		IC1001	C1ZBZ0004906	IC	1	E.S.D.
		IC1002	C0DBAYY02385	IC	1	E.S.D.
		IC1003	C0DBAYY02385	IC	1	E.S.D.
		IC1004	C0DBAYY02118	IC	1	E.S.D.
		IC1120	C0DBGYY03614	IC	1	E.S.D.
		IC1140	C0DBGYY03640	IC	1	E.S.D.
		IC1160	C0DBGYY05343	IC	1	E.S.D.
		IC1220	C0DBGYY03614	IC	1	E.S.D.
		IC1240	C0DBGYY02517	IC	1	E.S.D.
		IC1320	C0DBGYY03614	IC	1	E.S.D.
		IC2001	C9ZB00000670	IC	1	E.S.D.
		IC4101	C0DBAYY02207	IC	1	E.S.D.
		IC5101	C0JBAS000401	IC	1	E.S.D.
		IC5102	C0JBAS000401	IC	1	E.S.D.
		IC5304	C0DBGYY02176	IC	1	E.S.D.
		IC5403	C0BBAA000008	IC	1	E.S.D.
		IC6001	SCG0002	IC	1	E.S.D.
		IC6003	RS10792	IC	1	E.S.D.
		IC6201	L2EE00000045	IC	1	E.S.D.
		IC6601	C0DBGYY02368	IC	1	E.S.D.
		IC6602	C0DBGYY05584	IC	1	E.S.D.
		IC6603	C0DBGYY05590	IC	1	E.S.D.
		IC6604	C0DBGYY05582	IC	1	E.S.D.
		IC6605	C0ZBZ0002095	IC	1	E.S.D.
		IC6606	C0ZBZ0002095	IC	1	E.S.D.
		IC6607	C0ZBZ0002264	IC	1	E.S.D.
		IC6612	C1ZBZ0005532	IC	1	E.S.D.
		IC7001	C0GBY0000153	IC	1	E.S.D.
		IC7002	C0JBAB001130	IC	1	E.S.D.
		IC7003	C0JBAB001130	IC	1	E.S.D.
		IC7101	EWTS9PDL1A	IC	1	E.S.D. [INBD]

		IC9001	C0DBAYY00623	IC	1	E.S.D.
--	--	--------	--------------	----	---	--------

## Model No. : DMC-FZ300/330 Parts List

Change	Safety	Ref. No.	Part No.	Part Name & Description	Q'ty	Remarks
		IC9101	C1AB00003449	IC	1	E.S.D.
		JK2001	K1FY108E0007	JACK	1	
		JK2002	K1FY119E0057	JACK	1	
		JK2003	K2HD104D0002	JACK	1	
		JK9301	K2HC106E0009	JACK	1	
		L1010	G1C4R7MA0392	CHIP INDUCTOR 4.7UH	1	
		L1020	G1C100MA0461	CHIP INDUCTOR 10UH	1	
		L1030	G1C100MA0461	CHIP INDUCTOR 10UH	1	
		L1040	G1C100MA0461	CHIP INDUCTOR 10UH	1	
		L1050	G1C100MA0461	CHIP INDUCTOR 10UH	1	
		L1060	G1C2R2MA0477	CHIP INDUCTOR 2.2UH	1	
		L1080	G1C1R5MA0577	CHIP INDUCTOR 1.5UH	1	
		L1090	G1C4R7MA0477	CHIP INDUCTOR 4.7UH	1	
		L2001	EXC24CE900U	FILTER	1	
		L4102	G1C100MA0496	CHIP INDUCTOR 10UH	1	
		L4103	G1C100MA0496	CHIP INDUCTOR 10UH	1	
		L4104	G1C100MA0496	CHIP INDUCTOR 10UH	1	
		L6001	G1C2R2KA0096	CHIP INDUCTOR 2.2UH	1	
		L6501	G1C1R0MA0172	CHIP INDUCTOR 1UH	1	
		L9001	G1C100MA0392	CHIP INDUCTOR 10UH	1	
		LB2001	J0JCC0000415	FILTER	1	
		LB2002	J0JCC0000415	FILTER	1	
		LB2004	J0JCC0000415	FILTER	1	
		LB5401	J0JBC0000107	FILTER	1	
		LB5402	J0JBC0000107	FILTER	1	
		LB5403	J0JBC0000107	FILTER	1	
		LB5404	J0JBC0000107	FILTER	1	
		LB6001	J0JCC0000412	FILTER	1	
		LB6002	J0JFC0000006	FILTER	1	
		LB6003	J0JCC0000317	FILTER	1	
		LB6004	J0JCC0000408	FILTER	1	
		P6501	K1NA09E00153	SD CARD CONNECTOR	1	
		PS9001	K1KB30AA0116	CONNECTOR 30P	1	
		Q1090	MTM861270LBF	TRANSISTOR	1	E.S.D.
		Q2001	B1CFGD000003	TRANSISTOR	1	E.S.D.
		Q2002	B1CFJD000007	TRANSISTOR	1	E.S.D.
		Q4102	B1CZKC000002	TRANSISTOR	1	E.S.D.
		Q5301	B1ABCF000302	TRANSISTOR	1	E.S.D.
		Q6501	B1CHMB000007	TRANSISTOR	1	E.S.D.
		Q6503	B1ADCF000235	TRANSISTOR	1	E.S.D.
		Q8101	B1CFJD000007	TRANSISTOR	1	E.S.D.
		Q9000	MTM861280LBF	TRANSISTOR	1	E.S.D.
		Q9003	B1HFCFA00050	TRANSISTOR	1	E.S.D.
		Q9005	MTM861280LBF	TRANSISTOR	1	E.S.D.
		Q9101	B1ABCF000302	TRANSISTOR	1	E.S.D.
		Q9301	B1ABCF000302	TRANSISTOR	1	E.S.D.
		QR1080	B1GKCFJN0003	TRANSISTOR-RESISTOR	1	E.S.D.
		QR1090	B1GBCFYY0219	TRANSISTOR-RESISTOR	1	E.S.D.
		QR2003	B1GBCFYY0222	TRANSISTOR-RESISTOR	1	E.S.D.
		QR2004	B1GDGCFJN0026	TRANSISTOR-RESISTOR	1	E.S.D.
		QR4102	B1GFCELL0009	TRANSISTOR-RESISTOR	1	E.S.D.
		QR6501	B1GBCFJJ0064	TRANSISTOR-RESISTOR	1	E.S.D.
		QR6502	B1GDGCFYY0150	TRANSISTOR-RESISTOR	1	E.S.D.
		QR6602	B1GDGCFYY0148	TRANSISTOR-RESISTOR	1	E.S.D.
		QR8101	B1GFCEFJJ0016	TRANSISTOR-RESISTOR	1	E.S.D.
		QR8102	B1GFCEFJJ0016	TRANSISTOR-RESISTOR	1	E.S.D.
		QR8103	B1GKCFJN0003	TRANSISTOR-RESISTOR	1	E.S.D.
		QR9001	B1GBCFJJ0064	TRANSISTOR-RESISTOR	1	E.S.D.
		QR9002	B1GFCEFJJ0016	TRANSISTOR-RESISTOR	1	E.S.D.
		QR9006	B1GBCFJJ0064	TRANSISTOR-RESISTOR	1	E.S.D.
		QR9007	B1GBCFJJ0064	TRANSISTOR-RESISTOR	1	E.S.D.

		QR9008	B1GBCFJJ0064	TRANSISTOR-RESISTOR	1	E.S.D.
--	--	--------	--------------	---------------------	---	--------

**Model No. : DMC-FZ300/330 Parts List**

Change	Safety	Ref. No.	Part No.	Part Name & Description	Q'ty	Remarks
		QR9009	B1GBCFY0221	TRANSISTOR-RESISTOR	1	E.S.D.
		QR9102	B1GDCFY0150	TRANSISTOR-RESISTOR	1	E.S.D.
		R1001	D0GA102JA023	M.RESISTOR CH 1/10W 1K	1	
		R1002	D1BA4702A022	M.RESISTOR CH 1/16W 47K	1	
		R1061	D1BA2202A022	M.RESISTOR CH 1/16W 22K	1	
		R1063	D1BA2002A022	M.RESISTOR CH 1/16W 20K	1	
		R1081	D1BA1202A022	M.RESISTOR CH 1/16W 12K	1	
		R1083	D1BA3902A022	M.RESISTOR CH 1/16W 39K	1	
		R1086	D0GA103JA023	M.RESISTOR CH 1/10W 10K	1	
		R1091	D1BA6802A022	M.RESISTOR CH 1/16W 68K	1	
		R1092	D1BA1002A022	M.RESISTOR CH 1/16W 10K	1	
		R1095	D0GA103JA023	M.RESISTOR CH 1/10W 10K	1	
		R1096	D0GA103JA023	M.RESISTOR CH 1/10W 10K	1	
		R1097	D0GA103JA023	M.RESISTOR CH 1/10W 10K	1	
		R2001	D0GA101JA023	M.RESISTOR CH 1/10W 100	1	
		R2002	D0GA561JA023	M.RESISTOR CH 1/10W 560	1	
		R2003	D0GA102JA023	M.RESISTOR CH 1/10W 1K	1	
		R2004	D0GA102JA023	M.RESISTOR CH 1/10W 1K	1	
		R2005	D0GA750JA023	M.RESISTOR CH 1/10W 75	1	
		R2006	D0GB100JA065	M.RESISTOR CH 1/10W 10	1	
		R2007	D0GA473JA023	M.RESISTOR CH 1/10W 47K	1	
		R2008	D0GA273JA023	M.RESISTOR CH 1/10W 27K	1	
		R2009	D1BA2000A022	M.RESISTOR CH 1/16W 200	1	
		R2010	D0GA330JA023	M.RESISTOR CH 1/10W 33	1	
		R2011	D0GA330JA023	M.RESISTOR CH 1/10W 33	1	
		R2019	D0GA202JA023	M.RESISTOR CH 1/10W 2K	1	
		R2020	D0GA202JA023	M.RESISTOR CH 1/10W 2K	1	
		R4103	D0GAR00J0005	M.RESISTOR CH 1/10W 0	1	
		R4104	D0GAR00J0005	M.RESISTOR CH 1/10W 0	1	
		R4105	D0GAR00J0005	M.RESISTOR CH 1/10W 0	1	
		R4106	D1BA10R0A023	M.RESISTOR CH 1/16W 10	1	
		R4108	D0GA152JA023	M.RESISTOR CH 1/10W 1.5K	1	
		R4109	D0GA223JA023	M.RESISTOR CH 1/10W 22K	1	
		R5111	D0GA333JA023	M.RESISTOR CH 1/10W 33K	1	
		R5112	D0GA222JA023	M.RESISTOR CH 1/10W 2.2K	1	
		R5113	D0GA222JA023	M.RESISTOR CH 1/10W 2.2K	1	
		R5117	D0GA333JA023	M.RESISTOR CH 1/10W 33K	1	
		R5165	J0JBC0000107	FILTER	1	
		R5351	D0GA472JA023	M.RESISTOR CH 1/10W 4.7K	1	
		R5401	D0GA102JA023	M.RESISTOR CH 1/10W 1K	1	
		R5421	D1BA6802A022	M.RESISTOR CH 1/16W 68K	1	
		R5422	D1BA1102A022	M.RESISTOR CH 1/16W 11K	1	
		R6001	D0GA470JA023	M.RESISTOR CH 1/10W 47	1	
		R6004	D0GA103JA023	M.RESISTOR CH 1/10W 10K	1	
		R6005	D1BA5100A022	M.RESISTOR CH 1/16W 510	1	
		R6006	D1BA5100A022	M.RESISTOR CH 1/16W 510	1	
		R6007	D1BA5100A022	M.RESISTOR CH 1/16W 510	1	
		R6008	D1BA5100A022	M.RESISTOR CH 1/16W 510	1	
		R6009	D1BA5100A022	M.RESISTOR CH 1/16W 510	1	
		R6010	D1BA5100A022	M.RESISTOR CH 1/16W 510	1	
		R6011	D1BA5100A022	M.RESISTOR CH 1/16W 510	1	
		R6012	D1BA5100A022	M.RESISTOR CH 1/16W 510	1	
		R6013	D1BA5100A022	M.RESISTOR CH 1/16W 510	1	
		R6014	D1BA5100A022	M.RESISTOR CH 1/16W 510	1	
		R6015	D1BA5100A022	M.RESISTOR CH 1/16W 510	1	
		R6016	D1BA5100A022	M.RESISTOR CH 1/16W 510	1	
		R6017	D1BA2400A022	M.RESISTOR CH 1/16W 240	1	
		R6018	D1BA2400A022	M.RESISTOR CH 1/16W 240	1	
		R6019	D1BA2400A022	M.RESISTOR CH 1/16W 240	1	
		R6020	D1BA2400A022	M.RESISTOR CH 1/16W 240	1	
		R6021	D1BA8201A022	M.RESISTOR CH 1/16W 8.2K	1	



		R6022	D1BA1002A022	M.RESISTOR CH 1/16W 10K	1	
--	--	-------	--------------	-------------------------	---	--

**Model No. : DMC-FZ300/330 Parts List**

Change	Safety	Ref. No.	Part No.	Part Name & Description	Q'ty	Remarks
		R6026	D1BA6801A022	M.RESISTOR CH 1/16W 6.8K	1	
		R6027	D1BA4701A022	M.RESISTOR CH 1/16W 4.7K	1	PP, EE, GA, GC, GH, GT, GK, GN, GD, SG
		R6028	D1BA2000A022	M.RESISTOR CH 1/16W 200	1	
		R6032	D0GA470JA023	M.RESISTOR CH 1/10W 47	1	
		R6034	D0GAR00J0005	M.RESISTOR CH 1/10W 0	1	EG, EP, EF, EB
		R6035	D0GA473JA023	M.RESISTOR CH 1/10W 47K	1	
		R6036	D0GA151JA023	M.RESISTOR CH 1/10W 150	1	
		R6039	D0GA102JA023	M.RESISTOR CH 1/10W 1K	1	
		R6041	D0GA270JA023	M.RESISTOR CH 1/10W 27	1	
		R6042	D0GA101JA023	M.RESISTOR CH 1/10W 100	1	
		R6046	D0GA105JA023	M.RESISTOR CH 1/10W 1M	1	
		R6047	D0GA102JA023	M.RESISTOR CH 1/10W 1K	1	
		R6049	D1BA4701A022	M.RESISTOR CH 1/16W 4.7K	1	EG, EP, EF, EB
		R6062	D0GA202JA023	M.RESISTOR CH 1/10W 2K	1	
		R6063	D0GA202JA023	M.RESISTOR CH 1/10W 2K	1	
		R6120	D0GA102JA023	M.RESISTOR CH 1/10W 1K	1	
		R6501	D0GA102JA023	M.RESISTOR CH 1/10W 1K	1	
		R6502	D0GA223JA023	M.RESISTOR CH 1/10W 22K	1	
		R6504	D0GA104JA023	M.RESISTOR CH 1/16W 100K	1	
		R6505	D0GA103JA023	M.RESISTOR CH 1/10W 10K	1	
		R6509	D0GA102JA023	M.RESISTOR CH 1/10W 1K	1	
		R6510	D0GA680JA023	M.RESISTOR CH 1/10W 68	1	
		R6512	D0GA473JA023	M.RESISTOR CH 1/10W 47K	1	
		R6601	D0GA105JA023	M.RESISTOR CH 1/10W 1M	1	
		R6602	ERJ2BQJR51X	M.RESISTOR CH 1/10W 0.5	1	
		R6603	ERJ2BQJR51X	M.RESISTOR CH 1/10W 0.5	1	
		R6604	ERJ2BQJR51X	M.RESISTOR CH 1/10W 0.5	1	
		R6609	D1BA3302A022	M.RESISTOR CH 1/16W 33K	1	
		R6610	D1BA2202A022	M.RESISTOR CH 1/16W 22K	1	
		R6611	D1BA3302A022	M.RESISTOR CH 1/16W 33K	1	
		R6612	D1BA2202A022	M.RESISTOR CH 1/16W 22K	1	
		R6622	D1BA3602A022	M.RESISTOR CH 1/16W 36K	1	
		R6623	D1BA8202A022	M.RESISTOR CH 1/16W 82K	1	
		R7002	D1BA68R0A022	M.RESISTOR CH 1/16W 68	1	
		R7007	D1BA68R0A022	M.RESISTOR CH 1/16W 68	1	
		R7009	D1BA1R00A023	M.RESISTOR CH 1/16W 1	1	
		R7021	D1BA8201A022	M.RESISTOR CH 1/16W 8.2K	1	
		R7025	D0GA473JA023	M.RESISTOR CH 1/10W 47K	1	
		R7027	D0GA473JA023	M.RESISTOR CH 1/10W 47K	1	
		R8101	D0GA102JA023	M.RESISTOR CH 1/10W 1K	1	
		R8107	D0GD106JA052	M.RESISTOR CH 1/10W 10M	1	
		R8108	D0GD106JA052	M.RESISTOR CH 1/10W 10M	1	
		R8109	D0GA102JA023	M.RESISTOR CH 1/10W 1K	1	
		R8110	D0GA471JA023	M.RESISTOR CH 1/10W 470	1	
		R9001	D0GA153JA023	M.RESISTOR CH 1/10W 15K	1	
		R9003	D0GA821JA023	M.RESISTOR CH 1/10W 820	1	
		R9005	D0GA563JA023	M.RESISTOR CH 1/10W 56K	1	
		R9006	D0GA563JA023	M.RESISTOR CH 1/10W 56K	1	
		R9007	D0GA123JA023	M.RESISTOR CH 1/10W 12K	1	
		R9008	D0GA123JA023	M.RESISTOR CH 1/10W 12K	1	
		R9009	D0GA153JA023	M.RESISTOR CH 1/10W 15K	1	
		R9011	D0GA221JA023	M.RESISTOR CH 1/10W 220	1	
		R9012	D0GA221JA023	M.RESISTOR CH 1/10W 220	1	
		R9014	D0GA821JA023	M.RESISTOR CH 1/10W 820	1	
		R9015	D0GA473JA023	M.RESISTOR CH 1/10W 47K	1	
		R9016	D0GA103JA023	M.RESISTOR CH 1/10W 10K	1	
		R9020	D0GA102JA023	M.RESISTOR CH 1/10W 1K	1	
		R9021	D0GA102JA023	M.RESISTOR CH 1/10W 1K	1	
		R9022	D0GA102JA023	M.RESISTOR CH 1/10W 1K	1	
		R9023	D0GA102JA023	M.RESISTOR CH 1/10W 1K	1	
		R9024	D0GA470JA023	M.RESISTOR CH 1/10W 47	1	

	R9028	DOGA221JA023	M.RESISTOR CH 1/10W 220	1	
--	-------	--------------	-------------------------	---	--

**Model No. : DMC-FZ300/330 Parts List**

Change	Safety	Ref. No.	Part No.	Part Name & Description	Q'ty	Remarks
		R9033	DOGA102JA023	M.RESISTOR CH 1/10W 1K	1	
		R9035	DOGA103JA023	M.RESISTOR CH 1/10W 10K	1	
		R9036	DOGA103JA023	M.RESISTOR CH 1/10W 10K	1	
		R9052	DOGA102JA023	M.RESISTOR CH 1/10W 1K	1	
		R9061	JOJBC0000107	FILTER	1	
		R9064	DOGA332JA023	M.RESISTOR CH 1/10W 3.3K	1	
		R9076	DOGA201JA023	M.RESISTOR CH 1/10W 200	1	
		R9077	DOGA152JA023	M.RESISTOR CH 1/10W 1.5K	1	
		R9078	DOGA472JA023	M.RESISTOR CH 1/10W 4.7K	1	
		R9081	D1BA1003A022	M.RESISTOR CH 1/16W 100K	1	
		R9082	DOGB471JA065	M.RESISTOR CH 1/10W 470	1	
		R9084	D1BA1102A022	M.RESISTOR CH 1/16W 11K	1	
		R9085	DOGA512JA023	M.RESISTOR CH 1/10W 5.1K	1	
		R9092	DOGA473JA023	M.RESISTOR CH 1/10W 47K	1	
		R9094	D1BA2402A022	M.RESISTOR CH 1/16W 24K	1	
		R9095	D1BA1003A022	M.RESISTOR CH 1/16W 100K	1	
		R9096	DOGA223JA023	M.RESISTOR CH 1/10W 22K	1	
		R9097	DOGA473JA023	M.RESISTOR CH 1/10W 47K	1	
		R9098	DOGA103JA023	M.RESISTOR CH 1/10W 10K	1	
		R9103	DOGA512JA023	M.RESISTOR CH 1/10W 5.1K	1	
		R9106	ERJ2RKD105X	M.RESISTOR CH 1/16W 1M	1	
		R9107	D1BA2203A022	M.RESISTOR CH 1/16W 220K	1	
		R9109	DOGA331JA023	M.RESISTOR CH 1/10W 330	1	
		R9114	D1BA3902A022	M.RESISTOR CH 1/16W 39K	1	
		R9115	D1BA1203A022	M.RESISTOR CH 1/16W 120K	1	
		R9119	D1BA3302A022	M.RESISTOR CH 1/16W 33K	1	
		R9120	D1BA7502A022	M.RESISTOR CH 1/16W 75K	1	
		R9121	DOGA101JA023	M.RESISTOR CH 1/10W 100	1	
		R9123	DOGB330JA065	M.RESISTOR CH 1/10W 33	1	
		R9133	DOGA473JA023	M.RESISTOR CH 1/10W 47K	1	
		R9301	D1BB5601A074	M.RESISTOR CH 2W 5.6K	1	
		R9302	D1BB5601A074	M.RESISTOR CH 2W 5.6K	1	
		R9303	D1BB5601A074	M.RESISTOR CH 2W 5.6K	1	
		R9305	DOGA473JA023	M.RESISTOR CH 1/10W 47K	1	
		R9306	DOGA683JA023	M.RESISTOR CH 1/10W 68K	1	
		R9310	DOGA153JA023	M.RESISTOR CH 1/10W 15K	1	
		RX2003	EXB24V472JX	RESISTOR NETWORKS	1	
		RX4101	D1H8R0040016	RESISTOR NETWORKS	1	
		RX4102	D1H8R0040016	RESISTOR NETWORKS	1	
		RX4103	D1H8R0040016	RESISTOR NETWORKS	1	
		RX4104	D1H8R0040016	RESISTOR NETWORKS	1	
		RX6001	D1H81034A042	RESISTOR NETWORKS	1	
		RX6002	D1H81034A042	RESISTOR NETWORKS	1	
		RX6003	D1H84734A042	RESISTOR NETWORKS	1	
		RX6009	D1H81034A042	RESISTOR NETWORKS	1	
		RX6010	D1H81014A042	RESISTOR NETWORKS	1	
		RX6011	D1H81014A042	RESISTOR NETWORKS	1	
		RX6012	D1H81014A042	RESISTOR NETWORKS	1	
		RX6013	D1H81014A042	RESISTOR NETWORKS	1	
		RX6201	D1H82214A042	RESISTOR NETWORKS	1	
		RX6501	D1H84734A042	RESISTOR NETWORKS	1	
		RX6502	D1H86804A042	RESISTOR NETWORKS	1	
		RX8111	D1H83314A042	RESISTOR NETWORKS	1	
		RX8112	D1H81034A042	RESISTOR NETWORKS	1	
		RX9007	D1H84704A042	RESISTOR NETWORKS	1	
		RX9008	D1H84704A042	RESISTOR NETWORKS	1	
		RX9009	D1H84704A042	RESISTOR NETWORKS	1	
		RX9010	D1H84704A042	RESISTOR NETWORKS	1	
		RX9011	D1H81024A042	RESISTOR NETWORKS	1	
		RX9012	D1H81024A042	RESISTOR NETWORKS	1	
		RX9013	D1H81024A042	RESISTOR NETWORKS	1	

		RX9014	D1H83924A042	RESISTOR NETWORKS	1	
--	--	--------	--------------	-------------------	---	--

---

**Model No. : DMC-FZ300/330 Parts List**

---

Change	Safety	Ref. No.	Part No.	Part Name & Description	Q'ty	Remarks
		RX9101	D1H81024A042	RESISTOR NETWORKS	1	
		X6001	H0J240500048	CRYSTAL OSCILLATOR	1	
		X9101	H0J327200230	CRYSTAL OSCILLATOR	1	

Model No. : DMC-FZ300/330 Frame and Casing Section

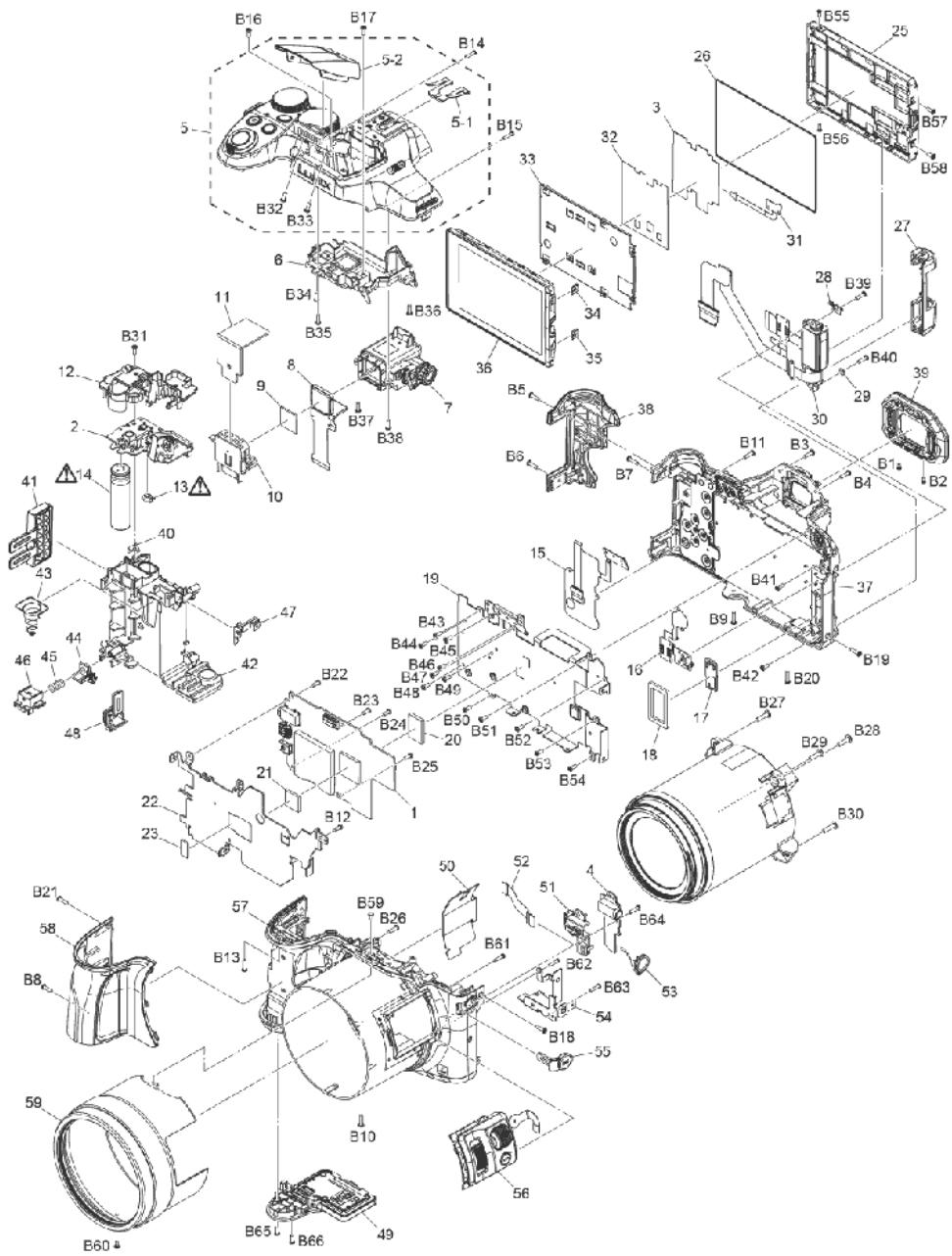

**Model No. : DMC-FZ300/330 Camera Lens Section**

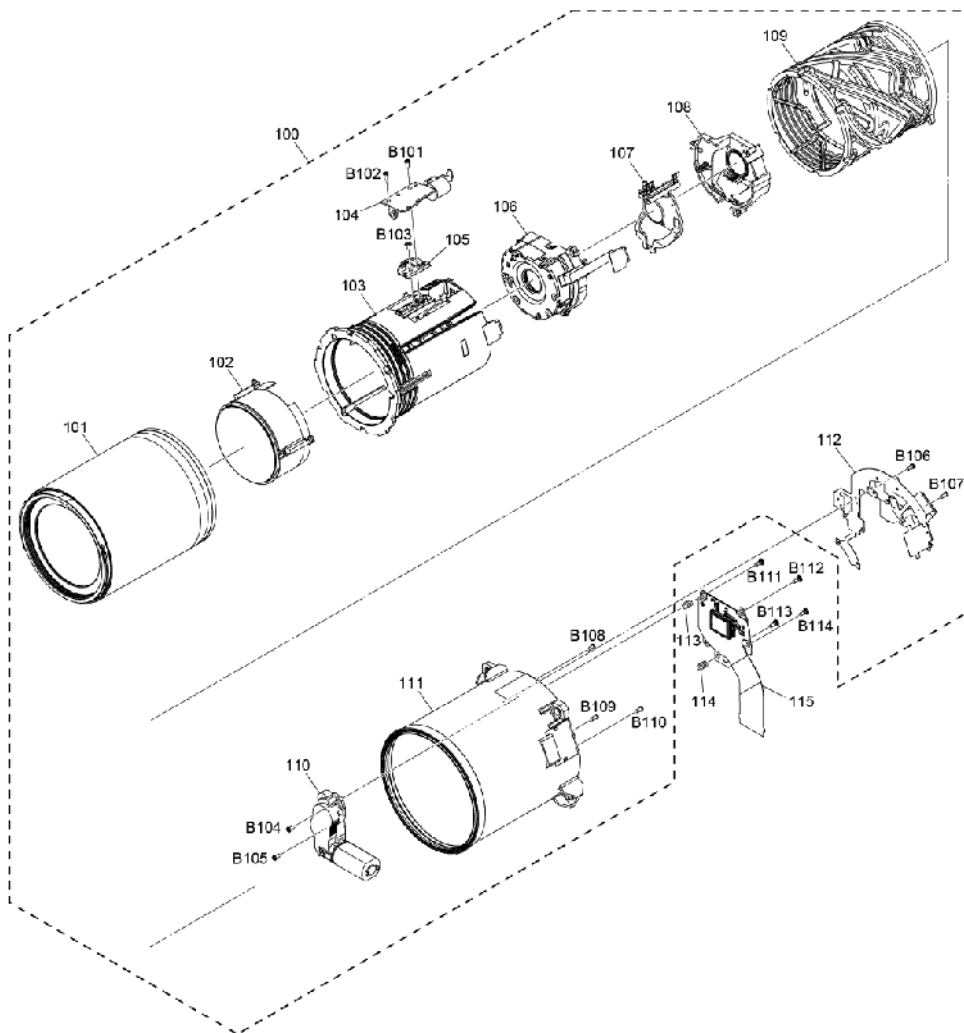



---

**Model No. : DMC-FZ300/330 Packing Parts and Accessories Section**

---

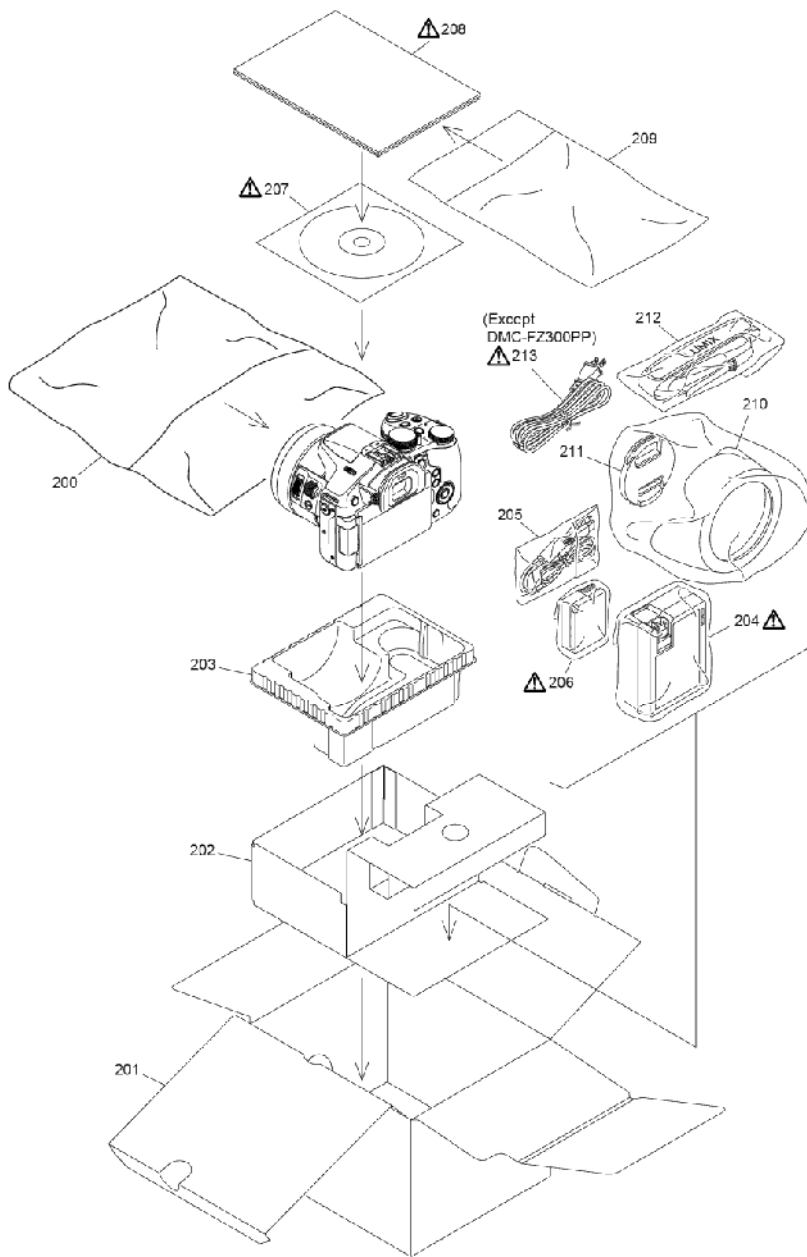

**Model No. : DMC-FZ300/330 Parts List**

Change	Safety	Ref. No.	Part No.	Part Name & Description	Q'ty	Remarks
		1	SEP0514AA	MAIN P.C.B.	1	(RTL) E.S.D. PP,EE,GA,GC,GH,GT,GK,GN,GD,SG
		1	SEP0514AB	MAIN P.C.B.	1	(RTL) E.S.D. EG,EP,EF,EB
		2	SEQ0104	FLASH P.C.B. UNIT	1	E.S.D.
		3	SEP0515AA	LCD IF P.C.B.	1	(RTL) E.S.D.
		4	SEP0517AA	MIC JACK P.C.B.	1	(RTL) E.S.D.
		5	SYK1136	TOP CASE UNIT	1	
		5-1	VMC2111	SHOE SPRING	1	
		5-2	SKK0307K	FLASH CASE TOP	1	
		6	SYQ0536	FLASH TRAY UNIT	1	
		7	SYQ0543	LVF UNIT	1	
		8	L5ZZ00000180	LVF MODULE	1	
		9	VMT2329	HEAT RADIATION PAD	1	
		10	SGQ0626	LVF COVER	1	
		11	SJD0007	LVF HEAT SINK	1	
		12	SGQ0621	CONDENSER COVER	1	
		13	ML-421S/DN	BUTTON BATTERY	1	[ENERGY]
		14	F2A2F1210006	E.CAPACITOR	1	
		15	SEW0114AA	REAR OPERATION FPC UNIT	1	
		16	SEP0524AA	HINGE SW FPC	1	
		17	VGQ1F77	HINGE FIX COVER	1	
		18	VGQ1F95	HINGE CUSHION 4	1	
		19	SYQ0542	REAR PLATE UNIT	1	
		20	SGQ0631	THERMAL SHEET B	1	
		21	SGQ0639	THERMAL SHEET A	1	
		22	SMP0208	BATTERY PLATE	1	
		23	SGQ0630	THERMAL SHEET C	1	
		25	SKK0310K	LCD CASE BOTTOM	1	
		26	VGQ1F96	LCD PACKING	1	
		27	SGQ0613	HINGE ARM COVER	1	
		28	SMP0206	HINGE EARTH	1	
		29	VGQ1R59	SPACER	1	
		30	SYK1144	LCD HINGE UNIT	1	
		31	SEP0433AA	MR SENSER FPC	1	E.S.D.
		32	SGQ0627	LCD BEZEL SHEET	1	
		33	SMP0205	LCD BEZEL	1	
		34	VMP0D70	LCD EARTH PLATE	1	
		35	VMP0D70	LCD EARTH PLATE	1	
		36	SYK1147	LCD UNIT	1	
		37	SYK1148	REAR CASE UNIT	1	
		38	SGQ0609	REAR GRIP	1	
		39	SYQ0540	EYE CUP UNIT	1	
		40	SMP0219	BATTERY EARTH	1	
		41	SKF0102K	JACK COVER	1	
		42	SYK1146	BATTERY CASE UNIT	1	
		43	VMB4409	BATTERY OUT SPRING	1	
		44	VGU0M81	BATTERY LOCK KNOB	1	
		45	VMB4407	BATTERY LOCK SPRING	1	
		46	SGQ0619	BATT LOCK KNOB COVER	1	
		47	SMP0209	BATTERY EARTH PLATE	1	
		48	SKF0101K	COUPLER COVER	1	
		49	SYF0070	BATTERY DOOR UNIT	1	
		50	SMP0196	FRONT PLATE	1	
		51	SGQ0618	MIC JACK HOLDER	1	
		52	STJ0142	JOINT FPC	1	
		53	L0AA01A00167	SPEAKER	1	
		54	SMP0197	SIDE FRAME	1	
		55	SKF0100K	MIC JACK COVER	1	
		56	SYU0058	SIDE OPERATION UNIT	1	
		57	SYK1145	FRONT CASE UNIT	1	
		58	SGQ0608	FRONT GRIP	1	

		59	SGK0237K	LENS RING	1	
--	--	----	----------	-----------	---	--

**Model No. : DMC-FZ300/330 Parts List**

Change	Safety	Ref. No.	Part No.	Part Name & Description	Q'ty	Remarks
		B1	VHD2431	SCREW	1	
		B2	VHD2431	SCREW	1	
		B3	VHD1839	SCREW	1	
		B4	VHD1839	SCREW	1	
		B5	VHD2178	SCREW	1	
		B6	VHD2178	SCREW	1	
		B7	VHD2178	SCREW	1	
		B8	VHD2178	SCREW	1	
		B9	VHD2178	SCREW	1	
		B10	VHD2178	SCREW	1	
		B11	VHD2178	SCREW	1	
		B12	VHD2178	SCREW	1	
		B13	VHD2178	SCREW	1	
		B14	VHD2178	SCREW	1	
		B15	VHD2178	SCREW	1	
		B16	VHD1870	SCREW	1	
		B17	VHD1870	SCREW	1	
		B18	VHD2438	SCREW	1	
		B19	VHD2438	SCREW	1	
		B20	VHD2438	SCREW	1	
		B21	VHD2438	SCREW	1	
		B22	XQN16+BJ4FN	SCREW	1	
		B23	XQN16+BJ4FN	SCREW	1	
		B24	XQN16+BJ4FN	SCREW	1	
		B25	XQN16+BJ4FN	SCREW	1	
		B26	XQN16+BJ4FN	SCREW	1	
		B27	XTV2+8JFN	SCREW	1	
		B28	XTV2+8JFN	SCREW	1	
		B29	XTV2+8JFN	SCREW	1	
		B30	XTV2+8JFN	SCREW	1	
		B31	XQN16+BJ4FN	SCREW	1	
		B32	VHD2476	SCREW	1	
		B33	VHD2476	SCREW	1	
		B34	XQN16+BJ5FN	SCREW	1	
		B35	XQN16+BJ5FN	SCREW	1	
		B36	XQN16+BJ5FN	SCREW	1	
		B37	VHD2371	SCREW	1	
		B38	VHD2371	SCREW	1	
		B39	VHD2178	SCREW	1	
		B40	VHD2178	SCREW	1	
		B41	VHD2178	SCREW	1	
		B42	VHD2178	SCREW	1	
		B43	XQN16+BJ4FN	SCREW	1	
		B44	XQN16+BJ4FN	SCREW	1	
		B45	XQN16+BJ4FN	SCREW	1	
		B46	XQN16+BJ4FN	SCREW	1	
		B47	XQN16+BJ4FN	SCREW	1	
		B48	XQN16+BJ4FN	SCREW	1	
		B49	XQN16+BJ4FN	SCREW	1	
		B50	XQN16+BJ4FN	SCREW	1	
		B51	XQN16+BJ4FN	SCREW	1	
		B52	XQN16+BJ4FN	SCREW	1	
		B53	XQN16+BJ4FN	SCREW	1	
		B54	XQN16+BJ4FN	SCREW	1	
		B55	VHD2206	SCREW	1	
		B56	VHD2206	SCREW	1	
		B57	VHD2337	SCREW	1	
		B58	VHD2337	SCREW	1	
		B59	VHD2149	SCREW	1	
		B60	VHD2536	SCREW	1	
		B61	VHD2262	SCREW	1	































		B62	VHD2262	SCREW	1	
--	--	-----	---------	-------	---	--

## Model No. : DMC-FZ300/330 Parts List

Change	Safety	Ref. No.	Part No.	Part Name & Description	Q'ty	Remarks
		B63	XQN16+BJ4FN	SCREW	1	
		B64	VHD2178	SCREW	1	
		B65	VHD2177	SCREW	1	
		B66	VHD2177	SCREW	1	
		100	SXW0265	LENS UNIT (W/O MOS)	1	
		101	SXP0092	1ST LENS FRAME UNIT	1	
		102	VXP3824	2ND LENS FRAME UNIT	1	
		103	SXP0115	MIDDLE FRAME UNIT	1	
		104	L6HAYYYD0056	FOCUS MOTOR UNIT	1	
		105	VMC2225	CAM FRAME SPRING	1	
		106	SXP0099	3RD LENS FRAME UNIT	1	
		107	SXP0116	4TH LENS FRAME UNIT	1	
		108	SXP0100	5TH LENS FRAME UNIT	1	
		109	VDW2567	CAM FRAME	1	
		110	L6DAYYYC0005	ZOOM MOTOR	1	
		111	SXQ0545	MASTER FLANGE UNIT	1	
		112	SEQ0106	LENS FLEX UNIT	1	
		113	VMB4205	TILT SPRING	1	
		114	VMB4205	TILT SPRING	1	
		115	SEQ0119	MOS UNIT	1	E.S.D.
		B101	VHD1974	SCREW	1	
		B102	VHD1974	SCREW	1	
		B103	VHD2109	SCREW	1	
		B104	VHD1974	SCREW	1	
		B105	VHD1974	SCREW	1	
		B106	VHD2109	SCREW	1	
		B107	VHD2109	SCREW	1	
		B108	VHD1974	SCREW	1	
		B109	VHD1974	SCREW	1	
		B110	VHD1974	SCREW	1	
		B111	VHD2351	SCREW	1	
		B112	VHD2351	SCREW	1	
		B113	VHD2351	SCREW	1	
		B114	VHD2351	SCREW	1	
		200	SPF0049	CAMERA BAG	1	
		201	SPK0124	PACKING CASE	1	PP, EG, EP, EF, EE, GA, GC, GH, GT, GN, GD
		201	SPK0138	PACKING CASE	1	SG [INBD]
		201	SPK0125	PACKING CASE	1	GK
		201	SPK0135	PACKING CASE	1	EB
		202	SPN0331	PAD	1	
		203	SPN0330	CUSHION	1	
	⚠	204	DE-A79BB/SX	BATTERY CHARGER	1	PP
	⚠	204	DE-A80AD/SX	BATTERY CHARGER	1	EG, EP, EF, EE, GN, EB
	⚠	204	DE-A80BE/SX	BATTERY CHARGER	1	GA, GC, GH, GK, GD
	⚠	204	DE-A80DA	BATTERY CHARGER	1	SG [INBD]
	⚠	204	DE-A80CC/SX	BATTERY CHARGER	1	GT
		205	K1HY08YY0031	USB CABLE W/PLUG	1	
	⚠	206	-----	BATTERY PACK	1	
	⚠	207	SFM0098	DVD (SOFT/INSTRUCTION BOOK)	1	PP See "Notes"
	⚠	207	SFM0099	DVD (SOFT/INSTRUCTION BOOK)	1	EG, EP, EF, EB See "Notes"
	⚠	207	SFM0100	DVD (SOFT/INSTRUCTION BOOK)	1	EE, GA, GC, GH, GN, SG See "Notes"
	⚠	207	SFM0100	DVD (SOFT/INSTRUCTION BOOK)	1	SG See "Notes" [INBD]
	⚠	207	SFM0101	DVD (SOFT/INSTRUCTION BOOK)	1	GT, GD See "Notes"
	⚠	207	SFM0102	DVD (SOFT/INSTRUCTION BOOK)	1	GK See "Notes"
	⚠	208	SQT0946	BASIC O/I (ENGLISH)	1	PP
	⚠	208	SQT0947	BASIC O/I (FRENCH)	1	PP
	⚠	208	SQT0948	BASIC O/I (SPANISH)	1	PP
	⚠	208	SQT0949	BASIC O/I (GERMAN)	1	EG
	⚠	208	SQT0950	BASIC O/I (FRENCH)	1	EG, EF
	⚠	208	SQT0951	BASIC O/I (ITALIAN)	1	EG

		208	SQT0952	BASIC O/I (DUTCH)	1	EG, EF
		208	SQT0953	BASIC O/I (SPANISH)	1	EG

**Model No. : DMC-FZ300/330 Parts List**

Change	Safety	Ref. No.	Part No.	Part Name & Description	Q'ty	Remarks
		208	SQT0954	BASIC O/I (PORTUGUESE)	1	EG
		208	SQT0956	BASIC O/I (FINNISH)	1	EP
		208	SQT0957	BASIC O/I (DANISH)	1	EP
		208	SQT0958	BASIC O/I (SWEDISH)	1	EP
		208	SQT0959	BASIC O/I (POLISH)	1	EP
		208	SQT0960	BASIC O/I (CZECH)	1	EP
		208	SQT0961	BASIC O/I (HUNGARIAN)	1	EP
		208	SQT0963	BASIC O/I (RUSSIAN)	1	EE
		208	SQT0964	BASIC O/I (UKRAINIAN)	1	EE
		208	SQT0965	BASIC O/I (ENGLISH)	1	GA, GH
		208	SQT0966	BASIC O/I (CHINESE (TRADITIONAL))	1	GA, GH
		208	SQT0967	BASIC O/I (ARABIC)	1	GA
		208	SQT0968	BASIC O/I (VIETNAMESE)	1	GA
		208	SQT0969	BASIC O/I (ENGLISH)	1	GC
		208	SQT0970	BASIC O/I (ARABIC)	1	GC
		208	SQT1120	BASIC O/I (ENGLISH)	1	SG [INBD]
		208	SQT1121	BASIC O/I (CHINESE (SIMPLIFIED))	1	SG [INBD]
		208	SQT0971	BASIC O/I (CHINESE (TRADITIONAL))	1	GT
		208	SQT0972	BASIC O/I (CHINESE (SIMPLIFIED))	1	GK
		208	SQT0973	BASIC O/I (ENGLISH)	1	GN
		208	SQT0974	BASIC O/I (KOREAN)	1	GD
		208	SQT0962	BASIC O/I (ENGLISH)	1	EB
		209	VPF1542	BAG, POLYETHYLENE	1	
		210	SYQ0547	LENS HOOD	1	
		211	VYQ5607	LENS CAP	1	
		212	VFC4453	SHOULDER STRAP	1	
		213	K2CP2YY00083	AC CORD W/PLUG	1	GA
		213	K2CQ2YY00082	AC CORD W/PLUG	1	EG, EP, EF, EE, GA
		213	K2CT3YY00034	AC CORD W/PLUG	1	GC, GH, EB
		213	K2CA2YY00247	AC CORD W/PLUG	1	SG [INBD]
		213	K2CA2YY00129	AC CORD W/PLUG	1	GT
		213	K2CA2YY00130	AC CORD W/PLUG	1	GK
		213	K2CJ2YY00052	AC CORD W/PLUG	1	GN
		213	K2CR2YY00026	AC CORD W/PLUG	1	GD