

Service Manual

Digital Camera

LUMIX



LEICA
DC VARIO-ELMARIT



DMC-FZ30PP

DMC-FZ30PL

DMC-FZ30EB

DMC-FZ30EG

DMC-FZ30EGM

DMC-FZ30GC

DMC-FZ30GD

DMC-FZ30GK

DMC-FZ30GN

DMC-FZ30GT

DMC-FZ30SG

Vol. 1

Colour

(S).....Silver Type

(K).....Black Type

WARNING

This service information is designed for experienced repair technicians only and is not designed for use by the general public. It does not contain warnings or cautions to advise non-technical individuals of potential dangers in attempting to service a product. Products powered by electricity should be serviced or repaired only by experienced professional technicians. Any attempt to service or repair the product or products dealt with in this service information by anyone else could result in serious injury or death.

Panasonic

© 2005 Matsushita Electric Industrial Co., Ltd. All rights reserved. Unauthorized copying and distribution is a violation of law.

TABLE OF CONTENTS

	PAGE	PAGE
1 Safety Precaution	3	
1.1. General Guidelines	3	
1.2. Leakage Current Cold Check	3	
1.3. Leakage Current Hot Check (See Figure 1.)	3	
1.4. How to Discharge the Capacitor on Flash PCB	4	
2 Warning	5	
2.1. Prevention of Electro Static Discharge (ESD) to Electrostatically Sensitive (ES) Devices	5	
2.2. How to Recycle the Lithium Ion Battery (U.S. Only)	5	
2.3. Caution for AC Cord (For EB/GC/SG)	6	
2.4. How to Replace the Lithium Battery	7	
3 Service Navigation	9	
3.1. Introduction	9	
3.2. About Lead Free Solder (PbF)	9	
3.3. Important Notice 1: (Other than U.S.A. and Canadian Market)	9	
3.4. How to Define the Model Suffix (NTSC or PAL model)	10	
4 Specifications	12	
5 Location of Controls and Components	13	
6 Service Mode	16	
6.1. Error Code Memory Function	16	
6.2. Confirmation of Firmware Version	19	
7 Service Fixture & Tools	20	
7.1. Service Fixture and Tools	20	
7.2. When Replacing the Main PCB	21	
7.3. Service Position	21	
8 Disassembly and Assembly Instructions	23	
8.1. Disassembly Flow Chart	23	
8.2. PCB Location	23	
8.3. Disassembly Procedure	24	
8.4. Disassembly Procedure for the Lens	34	
8.5. Assembly Procedure for the Lens	38	
8.6. Removal of the CCD	44	
9 Measurements and Adjustments	45	
9.1. Adjustment Procedures	45	
10 Maintenance	45	
10.1. Cleaning Lens, Viewfinder and LCD Panel	45	

1 Safety Precaution

1.1. General Guidelines

1. IMPORTANT SAFETY NOTICE

There are special components used in this equipment which are important for safety. These parts are marked by

 in the Schematic Diagrams, Circuit Board Layout, Exploded Views and Replacement Parts List. It is essential that these critical parts should be replaced with manufacturer's specified parts to prevent X-RADIATION, shock, fire, or other hazards. Do not modify the original design without permission of manufacturer.

2. An Isolation Transformer should always be used during the servicing of AC Adaptor whose chassis is not isolated from the AC power line. Use a transformer of adequate power rating as this protects the technician from accidents resulting in personal injury from electrical shocks. It will also protect AC Adaptor from being damaged by accidental shorting that may occur during servicing.
3. When servicing, observe the original lead dress. If a short circuit is found, replace all parts which have been overheated or damaged by the short circuit.
4. After servicing, see to it that all the protective devices such as insulation barriers, insulation papers shields are properly installed.
5. After servicing, make the following leakage current checks to prevent the customer from being exposed to shock hazards.

1.2. Leakage Current Cold Check

1. Unplug the AC cord and connect a jumper between the two prongs on the plug.
2. Measure the resistance value, with an ohmmeter, between the jumpered AC plug and each exposed metallic cabinet part on the equipment such as screwheads, connectors, control shafts, etc. When the exposed metallic part has a return path to the chassis, the reading should be between $1\text{ M}\Omega$ and $5.2\text{ M}\Omega$. When the exposed metal does not have a return path to the chassis, the reading must be infinity.

1.3. Leakage Current Hot Check (See Figure 1.)

1. Plug the AC cord directly into the AC outlet. Do not use an isolation transformer for this check.
2. Connect a $1.5\text{ k}\Omega$, 10 W resistor, in parallel with a $0.15\text{ }\mu\text{F}$ capacitor, between each exposed metallic part on the set and a good earth ground, as shown in Figure 1.
3. Use an AC voltmeter, with $1\text{ k}\Omega/\text{V}$ or more sensitivity, to measure the potential across the resistor.
4. Check each exposed metallic part, and measure the voltage at each point.
5. Reverse the AC plug in the AC outlet and repeat each of the above measurements.
6. The potential at any point should not exceed 0.75 V RMS . A leakage current tester (Simpson Model 229 or equivalent) may be used to make the hot checks, leakage current must not exceed $1/2\text{ mA}$. In case a measurement is outside of the limits specified, there is a possibility of a shock hazard, and the equipment should be repaired and rechecked before it is returned to the customer.

Hot-Check Circuit

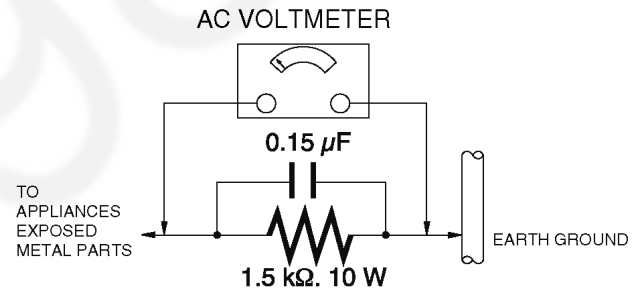

Figure. 1

1.4. How to Discharge the Capacitor on Flash PCB

CAUTION:

1. Be sure to discharge the capacitor on FLASH PCB.
2. Be careful of the high voltage circuit on FLASH PCB when servicing.

[Discharging Procedure]

1. Refer to the disassemble procedure and Remove the necessary parts/unit.
2. Put the insulation tube onto the lead part of Resistor (ERG5SJ102:1k Ω /5W).
(an equivalent type of resistor may be used.)
3. Put the resistor between both terminals of capacitor on FLASH PCB for approx. 5 seconds.
4. After discharging confirm that the capacitor voltage is lower than 10V using a voltmeter.

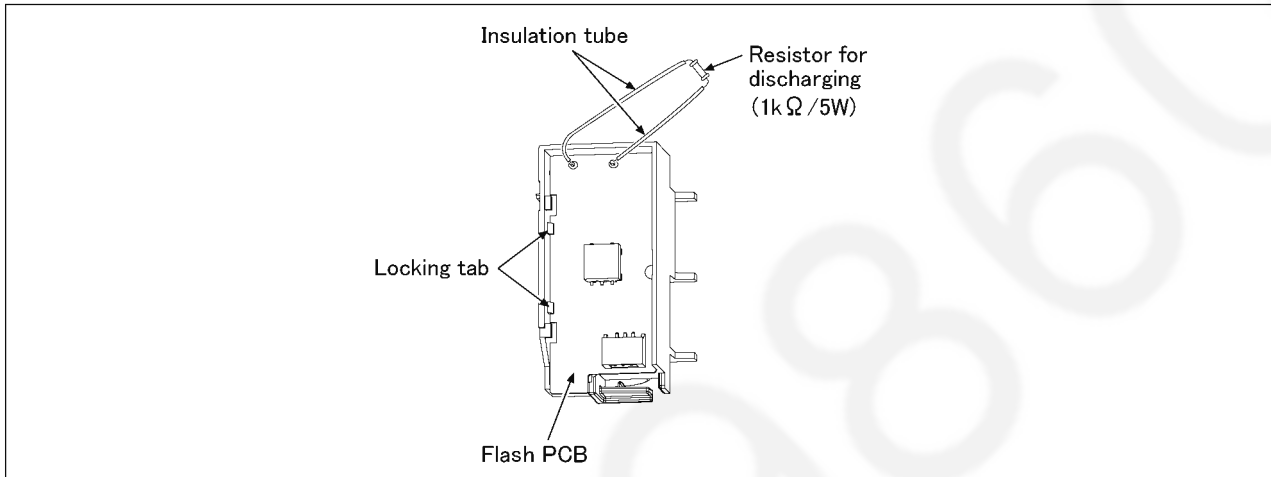

Fig. F1

2 Warning

2.1. Prevention of Electro Static Discharge (ESD) to Electrostatically Sensitive (ES) Devices

Some semiconductor (solid state) devices can be damaged easily by static electricity. Such components commonly are called Electrostatically Sensitive (ES) Devices. Examples of typical ES devices are integrated circuits and some field-effect transistors and semiconductor "chip" components. The following techniques should be used to help reduce the incidence of component damage caused by electro static discharge (ESD).

1. Immediately before handling any semiconductor component or semiconductor-equipped assembly, drain off any ESD on your body by touching a known earth ground. Alternatively, obtain and wear a commercially available discharging ESD wrist strap, which should be removed for potential shock reasons prior to applying power to the unit under test.
2. After removing an electrical assembly equipped with ES devices, place the assembly on a conductive surface such as aluminum foil, to prevent electrostatic charge buildup or exposure of the assembly.
3. Use only a grounded-tip soldering iron to solder or unsolder ES devices.
4. Use only an antistatic solder removal device. Some solder removal devices not classified as "antistatic (ESD protected)" can generate electrical charge sufficient to damage ES devices.
5. Do not use freon-propelled chemicals. These can generate electrical charges sufficient to damage ES devices.
6. Do not remove a replacement ES device from its protective package until immediately before you are ready to install it. (Most replacement ES devices are packaged with leads electrically shorted together by conductive foam, aluminum foil or comparable conductive material).
7. Immediately before removing the protective material from the leads of a replacement ES device, touch the protective material to the chassis or circuit assembly into which the device will be installed.

CAUTION :

Be sure no power is applied to the chassis or circuit, and observe all other safety precautions.

8. Minimize bodily motions when handling unpackaged replacement ES devices. (Otherwise harmless motion such as the brushing together of your clothes fabric or the lifting of your foot from a carpeted floor can generate static electricity (ESD) sufficient to damage an ES device).

2.2. How to Recycle the Lithium Ion Battery (U.S. Only)

ENGLISH



A lithium ion/polymer battery that is recyclable powers the product you have purchased. Please call 1-800-8-BATTERY for information on how to recycle this battery.

FRANÇAIS



L'appareil que vous vous êtes procuré est alimenté par une batterie au lithium-ion/polymère recyclable. Pour des renseignements sur le recyclage de la batterie, veuillez composer le 1-800-8-BATTERY.

2.3. Caution for AC Cord (For EB/GC/SG)

2.3.1. Information for Your Safety

IMPORTANT

Your attention is drawn to the fact that recording of pre-recorded tapes or discs or other published or broadcast material may infringe copyright laws.

WARNING

To reduce the risk of fire or shock hazard, do not expose this equipment to rain or moisture.

CAUTION

To reduce the risk of fire or shock hazard and annoying interference, use the recommended accessories only.

FOR YOUR SAFETY

DO NOT REMOVE THE OUTER COVER

To prevent electric shock, do not remove the cover. No user serviceable parts inside. Refer servicing to qualified service personnel.

2.3.2. Caution for AC Mains Lead

For your safety, please read the following text carefully.

This appliance is supplied with a moulded three-pin mains plug for your safety and convenience.

A 5-ampere fuse is fitted in this plug.

Should the fuse need to be replaced please ensure that the replacement fuse has a rating of 5 amperes and it is approved by ASTA or BSI to BS1362

Check for the ASRA mark or the BSI mark on the body of the fuse.



If the plug contains a removable fuse cover you must ensure that it is refitted when the fuse is replaced.

If you lose the fuse cover, the plug must not be used until a replacement cover is obtained.

A replacement fuse cover can be purchased from your local Panasonic Dealer.

If the fitted moulded plug is unsuitable for the socket outlet in your home then the fuse should be removed and the plug cut off and disposed of safely.

There is a danger of severe electrical shock if the cut off plug is inserted into any 13-ampere socket.

If a new plug is to be fitted please observe the wiring code as shown below.

If in any doubt, please consult a qualified electrician.

2.3.2.1. Important

The wires in this mains lead are coloured in accordance with the following code:

Blue	Neutral
Brown	Live

As the colours of the wires in the mains lead of this appliance may not correspond with the coloured markings identifying the terminals in your plug, proceed as follows:

The wire which is coloured BLUE must be connected to the terminal in the plug which is marked with the letter N or coloured BLACK.

The wire which is coloured BROWN must be connected to the terminal in the plug which is marked with the letter L or coloured RED.

Under no circumstances should either of these wires be connected to the earth terminal of the three pin plug, marked with the letter E or the Earth Symbol.



2.3.2.2. Before Use

Remove the Connector Cover as follows.

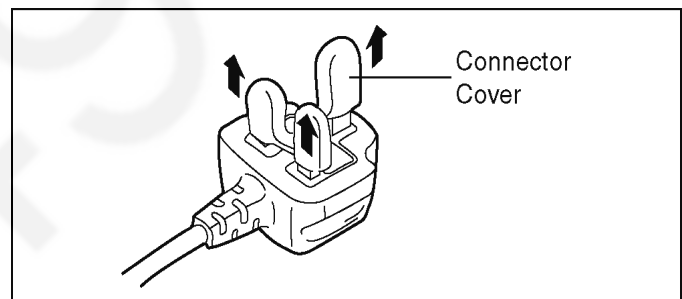

2.3.2.3. How to Replace the Fuse

1. Remove the Fuse Cover with a screwdriver.

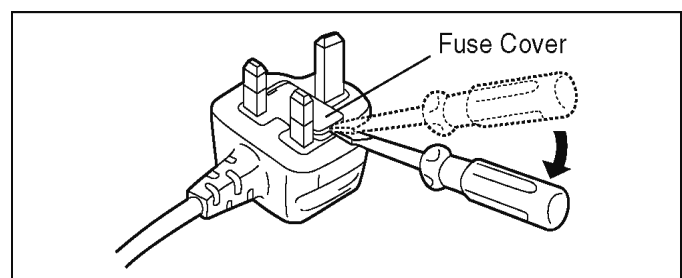

2. Replace the fuse and attach the Fuse cover.

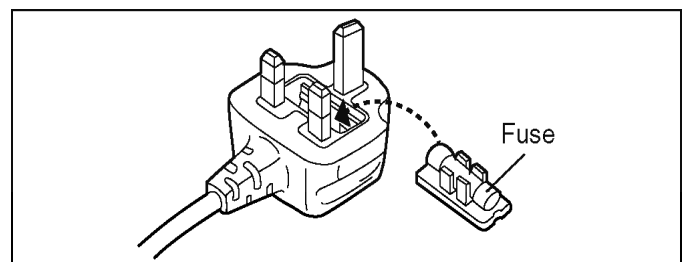

2.4. How to Replace the Lithium Battery

2.4.1. Replacement Procedure

1. Remove the MAIN PCB. (Refer to Disassembly Procedures.)
2. Remove the Lithium battery (Ref. No. "Z9101" at component side of MAIN PCB) and then replace it into new one.

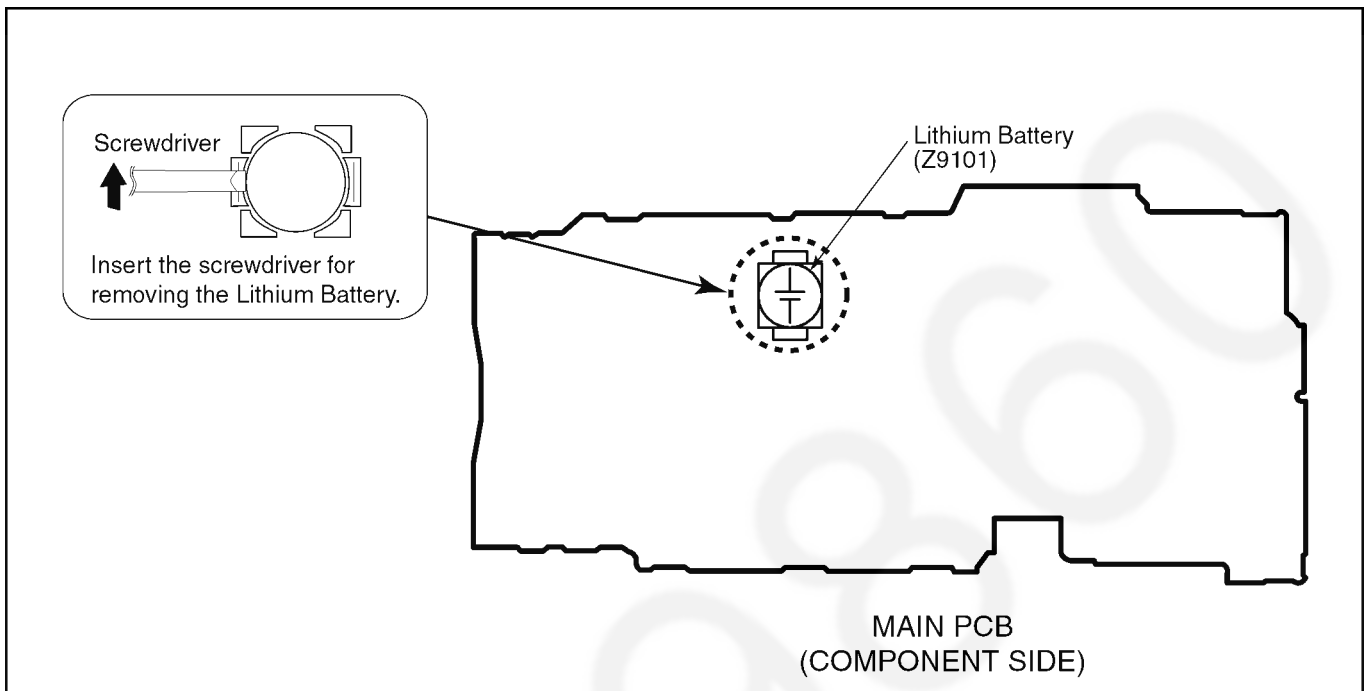

NOTE:

This Lithium battery is a critical component.

(Type No.: ML-614S/ZT **Manufactured by Matsushita Battery Industrial Co.,Ltd.**)

It must never be subjected to excessive heat or discharge.

It must therefore only be fitted in requirement designed specifically for its use.

Replacement batteries must be of same type and manufacture.

They must be fitted in the same manner and location as the original battery, with the correct polarity contacts observed.

Do not attempt to re-charge the old battery or re-use it for any other purpose.

It should be disposed of in waste products destined for burial rather than incineration.

(For English)

CAUTION

Danger of explosion if battery is incorrectly replaced.
Replace only with the same or equivalent type recommended by the manufacturer.
Dispose of used batteries according to the manufacturer's instructions.

(For French)

PRECAUTION

Le fait de remplacer incorrectement la pile peut présenter des risques d'explosion.
Remplacer la pile uniquement par une pile identique ou de type équivalent recommandée par le fabricant. Se débarrasser des piles usagées conformément aux instructions du fabricant.

(For German)

VORSICHT

Bei einer falsch eingesetzten Batterie besteht Explosionsgefahr. Nur mit einer vom Hersteller empfohlenen Batterie vom gleichen Typ ersetzen.
Verbrauchte Batterien beim Fachhändler oder einer Sammelstelle für Sonderstoffe abliefern.

(For Swedish)

VARNING

Explosionsfara vid felaktigt batteribyte.
Använd samma batterityp eller en ekvivalent typ som rekommenderas av apparatillverkaren.
Kassera använt batteri enligt fabrikantens instruktion.

(For Norwegian)

ADVARSEL!

Lithiumbatteri-Eksplosionsfare ved fejløgt håndtering.
Udskiftning må kun ske med batteri af samme fabrikat og type.
Levér det brugte batteri tilbage til leverandøren.

(For Finnish)

VAROITUS

Paristo voi räjähtää, jos se on virheellisesti asennettu.
Vaihda paristo ainoastaan laitevalmistajan suosittelemaan tyyppiin.
Hävitä käytetty paristo valmistajan ohjeiden mukaisesti.

NOTE:

Above caution is applicable for a battery pack which is for DMC-FZ30 series, as well.

3 Service Navigation

3.1. Introduction

This service manual contains technical information, which allow service personnel's to understand and service this model. Please place orders using the parts list and not the drawing reference numbers.

If the circuit is changed or modified, the information will be followed by service manual to be controlled with original service manual.

3.2. About Lead Free Solder (PbF)

Distinction of PbF PCB:

PCBs (manufactured) using lead free solder will have a PbF stamp on the PCB.

Caution:

- Pb free solder has a higher melting point than standard solder, Typically the melting point is 50-70°F (30-40°C) higher. Please use a high temperature soldering iron. In case of soldering iron with temperature control, please set it to 700±20°F (370±10°C).
- Pb free solder will tend to splash when heated too high (about 1100°F/600°C).

When soldering or unsoldering, please completely remove all of the solder on the pins or solder area, and be sure to heat the soldering points with the Pb free solder until it melts enough.

3.3. Important Notice 1:(Other than U.S.A. and Canadian Market)

1. The service manual does not contain the following information, because of the impossibility of servicing at component level.
 - a. Schematic diagram, Block Diagram and PCB layout of Main PCB.
 - b. Parts list for individual parts of Main PCB.When a part replacement is required for repairing Main PCB, replace as an assembled parts. (Main PCB)
2. The following category is/are recycle module part. please send it/them to Central Repair Center.
 - MAIN PCB (VEP56025A) : Excluding replacement of Lithium Battery

3.4. How to Define the Model Suffix (NTSC or PAL model)

There are seven kinds of DMC-FZ30, regardless of the colours.

- a) DMC-FZ30S
- b) DMC-FZ30PP
- c) DMC-FZ30EB/EG/EGM/GN
- d) DMC-FZ30GC/SG
- e) DMC-FZ30GD
- f) DMC-FZ30GT
- g) DMC-FZ30PL/GK

(DMC-FZ30S is exclusively Japan domestic model.)

What is the difference is that the "INITIAL SETTING" data which is stored in Flash ROM mounted on Main PCB.

3.4.1. Defining methods:

To define the model suffix to be serviced, refer to the nameplate which is putted on the bottom side of the Unit.

a) DMC-FZ30S
DMC-FZ30S is exclusively Japan domestic model.

b) DMC-FZ30PP
The nameplate for this model show the following Safty registration mark.



c) DMC-FZ30EB/EG/EGM/GN
The nameplate for these models show the following Safty registration mark.



d) DMC-FZ30GC/SG
The nameplate for these models show the following Safty registration mark.



e) DMC-FZ30GD
The nameplate for this model show the following Safty registration mark.



f) DMC-FZ30GT
The nameplate for this model show the following Safty registration mark.



g) DMC-FZ30PL/GK
The nameplate for these models do not show any above Safty registration mark.



Safty registration mark

NOTE:

After replacing the MAIN PCB, be sure to achieve adjustment.

The adjustment instruction is available at "software download" on the "Support Information from NWBG-PAVC" web-site in "TSN system", together with Maintenance software.

3.4.2. INITIAL SETTINGS:

CAUTION:

NEVER select “NONE(JAPAN)” if the unit is other than “JAPAN” model.

Other-wise, it can not be reset to the other.

When you replace the Main PCB be sure to perform the initial settings after achieving the Adjustment, by ordering the following procedure in accordance with model suffix.

• **Step 1. The temporary cancellation of factory setting:**

Set the mode dial to “[P]”.

While keep pressing [Optical Image Stabilizer] and “[UP] of Cross key” simultaneously, turn the Power on.

• **Step 2. The cancellation of factory setting:**

Set the mode dial to “[Playback]”.

While keep pressing [Optical Image Stabilizer] and “[UP] of Cross key” simultaneously, turn the Power on.

• **Step 3. Turn the Power on:**

Set the mode dial to “[P]”, and then turn the Power on.

• **Step 4. Display the INITIAL SETTING:**

While keep pressing [MENU] and “[RIGHT] of Cross key” simultaneously, turn the Power off.

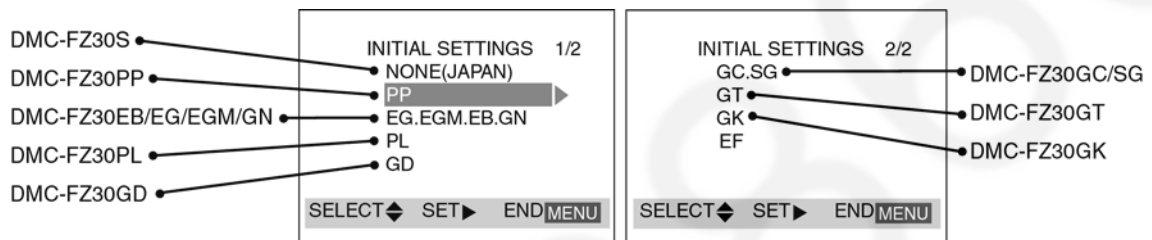

• **Step 5. Set the INITIAL SETTING:**

Select the area with pressing “[UP] / [DOWN] of Cross key”, and then press the “[RIGHT] of Cross key”.

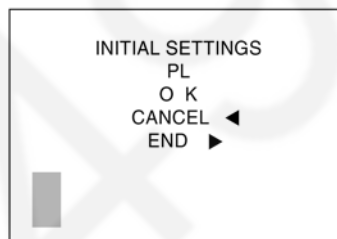

The only set area is displayed, and then press the “[RIGHT] of Cross key” after confirmation.

(The unit is powered off automatically.)

Confirm the display of “PLEASE SET THE CLOCK” in English when the unit is turned on again.

• **Step 6. CONFIRMATION:**

The display shows “PLEASE SET THE CLOCK” when turn the Power on again.

Connect the unit to PC with USB cable and is detected as removable media.

(For China and Taiwan marker, the display shows “PLEASE SET THE CLOCK” in Chinese.)

1) As for your reference Default setting condition is given in the following table.

• **Default setting (After “INITIAL SETTINGS”)**

	MODEL	VIDEO OUTPUT	LANGUAGE	DATE	REMARKS
a)	DMC-FZ30S	NTSC	Japanese	Year/Month/Date	
b)	DMC-FZ30PP/PL	NTSC	English	Month/Date/Year	
c)	DMC-FZ30EB/EG/EGM/GC/GN/SG	PAL	English	Date/Month/Year	
d)	DMC-FZ30GK	PAL	Chinese (simplified)	Year/Month/Date	
e)	DMC-FZ30GT	NTSC	Chinese (traditional)	Year/Month/Date	
f)	DMC-FZ30GD	NTSC	English	Year/Month/Date	

4 Specifications

Digital Camera: Information for your safety

Power Source:	DC 8.4 V
Power Consumption:	2.1 W (When recording with LCD Monitor) 2.0 W (When recording with Viewfinder) 1.2 W (When playing back with LCD Monitor) 1.1 W (When playing back with Viewfinder)
Camera Effective pixels:	8,000,000 pixels
Image sensor:	1/1.8" CCD, total pixel number 8,320,000 pixels Primary color filter
Lens:	Optical 12× zoom, f=7.4 mm to 88.8 mm (35 mm film camera equivalent: 35 mm to 420 mm)/F2.8 to F3.7
Digital zoom:	Max. 4×
Focus:	Normal/AF MACRO/Manual/Macro, 9-area-focusing/ 3-area-focusing (High speed)/1-area-focusing (High speed)/ 1-area-focusing/Spot-focusing
Focus range:	AF: 30 cm (0.98 feet) (Wide)/2 m (6.56 feet) (Tele) to ∞ AF MACRO/MF: 5 cm (0.16 feet) (Wide)/ 2 m (6.56 feet) (Tele) to ∞
Shutter system:	Electronic shutter+Mechanical shutter
Burst recording	
Burst speed:	3 frames/second (High speed), 2 frames/second (Low speed), Approx. 2 frames/second (Unlimited)
Number of recordable pictures:	Max. 9 frames (Standard), max. 5 frames (Fine), Depends on the remaining capacity of the card. (Unlimited) (Performance in burst recording is only with SD Memory Card. MultiMediaCard performance will be less.)
Motion picture recording:	640×480 pixels/320×240 pixels (30 or 10 frames/second with audio. The maximum recording time depends on the capacity of the card.)
ISO sensitivity:	AUTO/80/100/200/400
Shutter speed:	60 to 1/2000th [STARRY SKY] mode: 15 seconds, 30 seconds, 60 seconds AUTO/Daylight/Cloudy/Halogen/Flash/White set1/White set2
White balance:	
Exposure (AE):	Program AE (P)/Aperture-priority AE (A)/ Shutter-priority AE (S)/Manual exposure (M) Exposure compensation (1/3 EV Step, -2 EV to +2 EV)
Metering mode:	Multiple/Center weighted/Spot
LCD monitor:	2.0" low-temperature polycrystalline TFT LCD (235,000 pixels) (field of view ratio about 100%)
Viewfinder:	Color LCD Viewfinder (235,000 pixels) (field of view ratio about 100%) (with diopter adjustment -4 to +4 diopter)
Flash:	Built-in pop up flash Flash range: (ISO AUTO) Approx. 30 cm (0.98 feet) to 7.0 m (23.0 feet) (Wide)

Microphone:	AUTO, AUTO/Red-eye reduction, Forced ON (Forced ON/Red-eye reduction), Slow sync./Red-eye reduction, Forced OFF
Speaker:	Monaural
Recording media:	Monaural
Picture size	SD Memory Card/MultiMediaCard
Still picture:	When the aspect ratio setting is [4:3] 3264×2448 pixels, 2560×1920 pixels, 2048×1536 pixels, 1600×1200 pixels, 1280×960 pixels When the aspect ratio setting is [16:9] 3072×1728 pixels, 1920×1080 pixels When the aspect ratio setting is [3:2] 3248×2160 pixels, 2560×1712 pixels, 2048×1360 pixels, 640×480 pixels/320×240 pixels Fine/Standard/TIFF/RAW
Motion pictures:	
Quality:	JPEG (Design rule for Camera File system, based on Exif 2.2 standard)/TIFF (RGB), DPOF corresponding
Recording file format	JPEG (Design rule for Camera File system, based on Exif 2.2 standard)+640×480 pixels
Still Picture:	QuickTime (picture with audio) QuickTime Motion JPEG (motion pictures with audio)
Motion pictures:	
Interface	
Digital:	USB 2.0 (Full Speed)
Analog video/audio:	NTSC/PAL Composite (Switched by menu), Audio line output (monaural)
Terminal	
REMOTE:	φ 2.5 mm jack
AV OUT/DIGITAL:	Dedicated jack (8 pin)
DC IN:	type 3 jack
Dimensions:	140.75 mm (W)×85.5 mm (H)×138.1 mm (D) (5 9/16" (W)× 3 3/8" (H)×5 7/16" (D)) (excluding the projection part)
Mass:	Approx. 674 g/23.8 oz (excluding Memory Card and battery) Approx. 740 g/26.1 oz (with Memory Card and battery)
Operating Temperature:	0 °C to 40 °C (32 °F to 104 °F)
Operating Humidity:	10% to 80%
Battery Charger :	Information for your safety
Input:	110 to 240 V~50/60 Hz, 0.15 A
Output:	CHARGE 8.4 V---0.43 A
Equipment mobility:	Movable
Battery Pack (lithium-ion)	
(Panasonic CGR-S006A):	Information for your safety
Voltage/capacity:	7.2 V, 710 mAh

5 Location of Controls and Components

Names of the Components

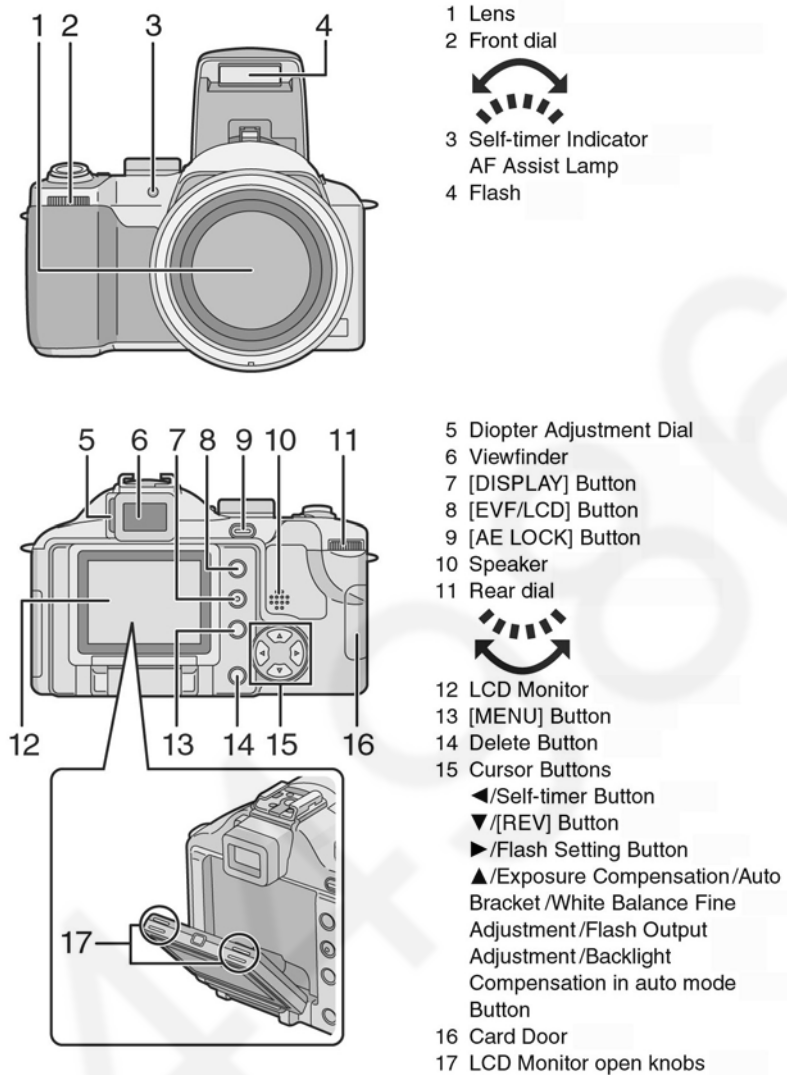

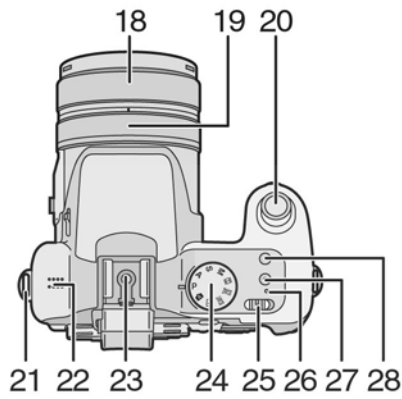

- 18 Zoom ring
- 19 Focus ring
- 20 Shutter Button
- 21 Strap Eyelet
- 22 Microphone
- 23 Hot Shoe
- 24 Mode Dial
- 25 Camera ON/OFF Switch
- 26 Power Indicator
- 27 Single or Burst Mode Button
- 28 Optical Image Stabilizer Button

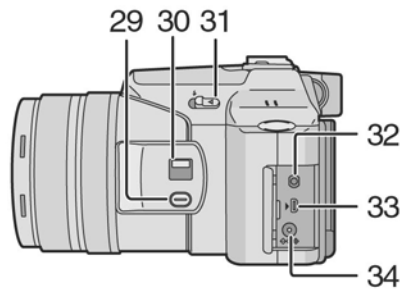

- 29 [FOCUS] Button
- 30 Focus Switch (AF/AF MACRO/MF)
- 31 Flash Open Lever
- 32 [REMOTE] Socket
- 33 [AV OUT/DIGITAL] Socket
- 34 [DC IN] Socket
- Please be sure to use genuine Panasonic AC adaptor (DMW-CAC1; optional).

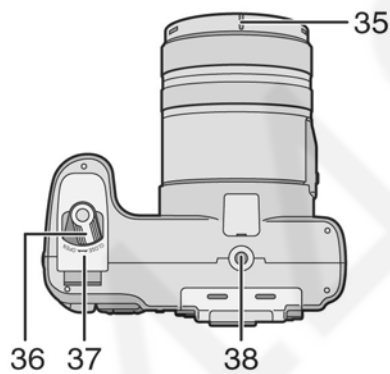

- 35 Lens hood positioning groove
- 36 Battery Door Open/Close Lever
- 37 Battery Door
- 38 Tripod Receptacle
- When you use a tripod, make sure the tripod is stable with the camera attached to it.

The Mode Dial

This camera has a mode dial to suit recording of many kinds of scenes. Select the desired mode and enjoy the variety of recording. Rotate the mode dial slowly and securely.

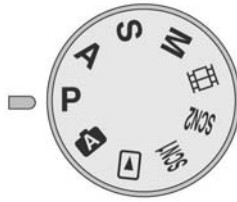

P : Program AE mode

The exposure is automatically adjusted by the camera.

A : Aperture-priority AE

The shutter speed is automatically determined by the aperture value you set.

S : Shutter-priority AE

The aperture value is automatically determined by the shutter speed you set.

M : Manual exposure

The exposure is adjusted by the aperture value and the shutter speed which are manually adjusted.

: Motion picture mode

This mode allows you to record motion pictures.

SCN1 : Scene mode 1

SCN2 : Scene mode 2

This mode allows you to take pictures depending on the recording scenes.

This mode also allows you to set [SCENE MENU] on the [SETUP] menu to [OFF] and set the scene modes which are frequently used to [SCN1] and [SCN2] on the mode dial.

It is convenient because you can select the scene mode quickly and minimize the operation.

: Playback mode

This mode allows you to play back recorded pictures.

A : Auto mode

Even beginners can easily take pictures.

6 Service Mode

6.1. Error Code Memory Function

1. General description

This unit is equipped with history of error code memory function, and can be memorized 32 error codes in sequence from the latest. When the error is occurred more than 32, oldest error is overwritten in sequence.

The error code is not memorized when the power supply is shut down forcibly (when the unit is powered on by the battery, the battery is pulled out) because the error code is memorized to FLASH ROM when the unit is powered off.

2. How to display

The error code can be displayed by the following procedure:

Before perform the error code memory function, connect the AC adaptor or insert the battery, and insert the SD card.

• 1. The temporary cancellation of factory setting:

Set the mode dial to "[P]".

While pressing [Optical Image Stabilizer Button] and "[UP] of Cross key" simultaneously and hold them, turn the Power on.

• 2. The display of error code:

Press [Optical Image Stabilizer Button], [MENU] and "[LEFT] of Cross key" simultaneously with the step 1 condition.

The display is changed as shown below when the above buttons is pressed simultaneously.

Normal display → Error code display → Operation history display → Normal display →

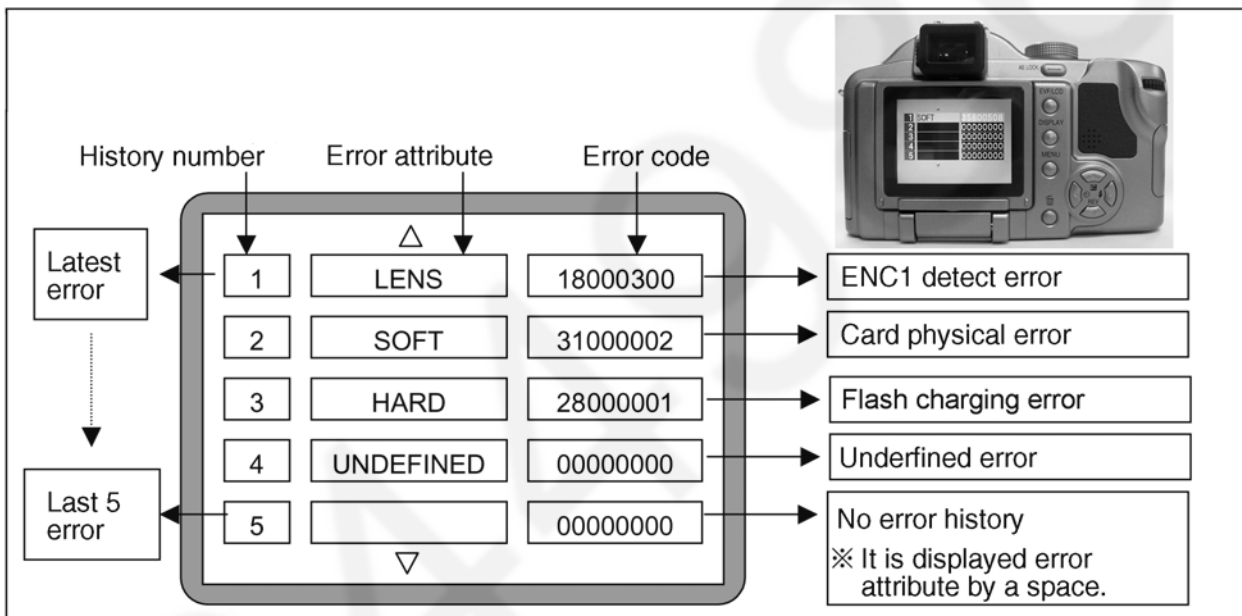

Example of Error Code Display

• 3. The change of display:

The error code can be memorized 32 error codes in sequence, however it is displayed 5 errors on the LCD.

Display can be changed by the following procedure:

"[UP] or [DOWN] of Cross key" : It can be scroll up or down one.

"[LEFT] or [RIGHT] of Cross key" : It can be display last 5 error or another 5 error.

• 4. How to read the error code:

One error code is displayed for 8 bit, the contents of error codes is indicated the table as shown below.

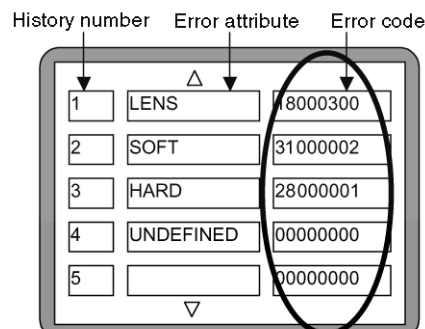

Attribute	Main item	Sub item	Error code		Contents (Upper)	
			High 4 bits	Low 4 bits	Check point (Lower)	
LENS	Lens drive	OIS	1800	1000	PSD (X) error. Hall element (X axis) position detect error in OIS unit. OIS Unit	
				2000	PSD (Y) error. Hall element (Y axis) position detect error in OIS unit. OIS Unit	
				3000	GYRO (X) error. Gyro (IC7102: X axis) detect error on Main C.B.A.. IC7102 (Gyro element) or IC6001 (VENUS 2)	
				4000	GYRO (Y) error. Gyro (IC7101: Y axis) detect error on Main C.B.A.. IC7101 (Gyro element) or IC6001 (VENUS 2)	
				5000	MREF error (Reference voltage error). IC7002 (LENS drive) or IC6001 (VENUS 2)	
				6000	Drive voltage (X) error. VENUS 2 AD value error, LENS Unit, LENS flex breaks etc.	
				7000	Drive voltage (Y) error. VENUS 2 AD value error, LENS Unit, LENS flex breaks etc.	
			C.B./Zoom	0100	HP Low detect error (C.B. encoder (full retract) always Low detect). FP9008-(28) signal line or IC6001 (VENUS 2)	
				0200	HP High detect error (C.B. encoder (full retract) always High detect). FP9008-(28) signal line or IC6001 (VENUS 2)	
				0300	ENC1 detect error (C.B. motor encoder detect error).	
				0400	ENC2 detect error (C.B. motor encoder detect error).	
				Zoom	0010	HP Low detect error (Zoom encoder always Low detect error).
					0020	HP High detect error (Zoom encoder always High detect error).
			0030		ENC1 detect error (Zoom encoder detect error).	
		0040	ENC2 detect error (Zoom encoder detect error).			
		Focus	0001	HP Low detect error (Focus encoder always Low detect error). FP9008-(28) signal line or IC6001 (VENUS 2)		
			0002	HP High detect error (Focus encoder always High detect error). FP9008-(28) signal line or IC6001 (VENUS 2)		
			0003	MR A aspect output error FP9008-(32) signal line or IC6001 (VENUS 2)		
			0004	MR B aspect output error FP9008-(30) signal line or IC6001 (VENUS 2)		
		Lens	1801	0000	Power ON time out error. Lens drive system	
				1802	0000	Power OFF time out error. Lens drive system
		Adj.History	OIS	1900	2000	OIS adj. Yaw direction amplitude error (small)
					3000	OIS adj. Pit direction amplitude error (small)
					4000	OIS adj. Yaw direction amplitude error (large)
					5000	OIS adj. Pit direction amplitude error (large)
					6000	OIS adj. MREF error
					7000	OIS adj. time out error
					8000	OIS adj. Yaw direction off set error
	9000				OIS adj. Pit direction off set error	
	A000				OIS adj. Yaw direction gain error	
	B000				OIS adj. Pit direction gain error	
	C000				OIS adj. Yaw direction position sensor error	
D000	OIS adj. Pit direction position sensor error					
E000	OIS adj. other error					
HARD	VENUS A/D				Flash	2800
	FLASH ROM (EEPROM Area)	FLASH ROM (EEPROM Area)	2B00	0001	EEPROM read error IC6002 (FLASH ROM)	
				0002	EEPROM write error IC6002 (FLASH ROM)	
	SYSTEM	RTC	2C00	0001	SYSTEM IC initialize failure error Communication between IC6001 (VENUS 2) and IC9101 (SYSTEM)	

Attribute	Main item	Sub item	Error code		Contents (Upper)
			High 4 bits	Low 4 bits	Check point (Lower)
SOFT	CPU	Reset	3000	0001	NMI reset
				0007	Non Mask-able Interrupt (30000001-30000007 are caused by factors)
	Card	Card	3100	0001	Card logic error SD card data line or IC6001 (VENUS 2)
				0002	Card physical error SD card data line or IC6001 (VENUS 2)
				0004	Write error SD card data line or IC6001 (VENUS 2)
				0005	Format error SD card data line or IC6001 (VENUS 2)
	CPU, ASIC hard	Stop	3800	0001	Camera task finish process time out. Communication between Lens system and IC6001 (VENUS 2)
				0002	Camera task invalid code error. IC6001 (VENUS 2)
				0100	File time out error in recording motion image IC6001 (VENUS 2)
				0200	File data send error in recording motion image IC6001 (VENUS 2)
		1000		AF frame movement check time out. IC6001 (VENUS 2)	
		Monitor			
	Operation	Power on	3B00	0000	FLASHROM processing early period of camera during movement.
	Zoom	Zoom	3C00	0000	I do not complete zoom lens processing Zoom lens
				0000	I jumped into dummy processing (0-7bit : command, 8-15bit : Status)
				0000	Though record preprocessing is necessary, it is not called.
				0000	Though record preprocessing is necessary, it is not completed.

• **5. How to returned to Normal Display:**

Turn the power off and on, to exit from Error code display mode.

NOTE:

The error code can not be initialized by the unit only.

6.2. Confirmation of Firmware Version

The Firmware version can be confirmed by ordering the following steps:

- **Step 1. The temporary cancellation of factory setting:**

Set the mode dial to "[P]".

While keep pressing [Optical Image Stabilizer] and "[UP] of Cross key" simultaneously, turn the power on with inserting the SD memory card which has a few photo data.

- **Step 2. Confirm the version:**

Set the mode dial to "[Playback]" and then press [DISPLAY] to switch to LCD with indication. (Fig. A)

Press [Optical Image Stabilizer] and "[DOWN] of Cross key" simultaneously. (No need to keep pressing.)

(The version information is displayed on the LCD with light blue colour letters.) (Fig. B)

CAUTION:

The version information does not display if the LCD has switched to LCD with indication already.

In this case, press [DISPLAY] to switch to LCD with indication.

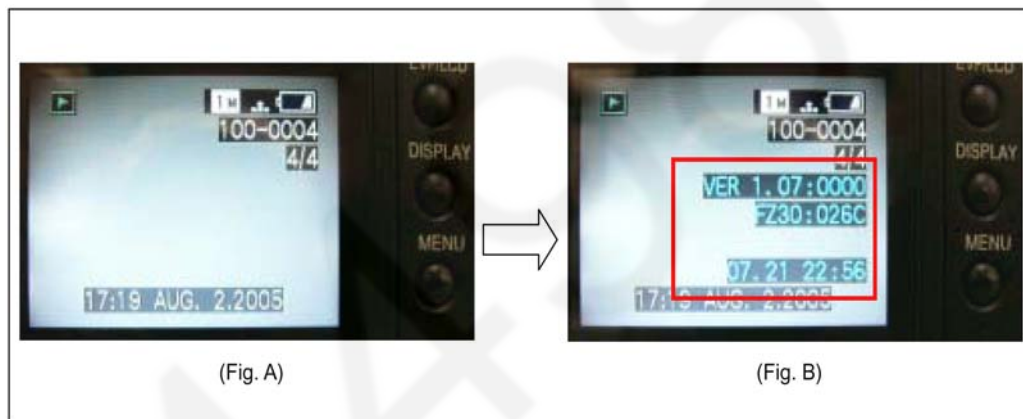
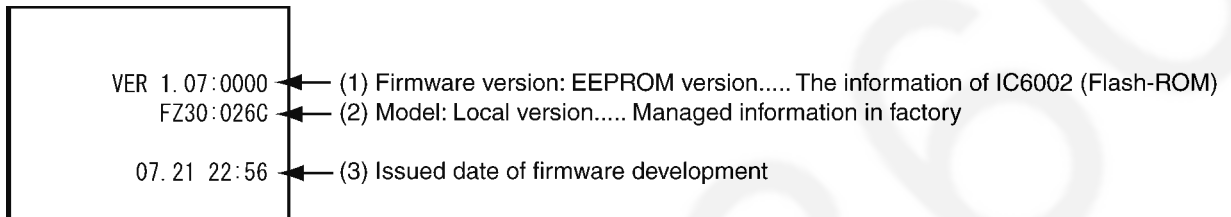





<Point>

- The firmware version and EEPROM version can be confirmed with the information (1).
- The information (2), (3) are just reference.

7 Service Fixture & Tools

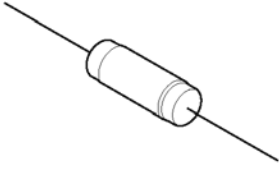
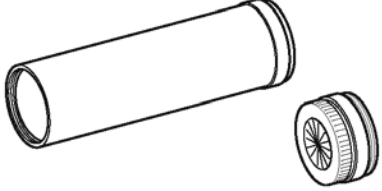
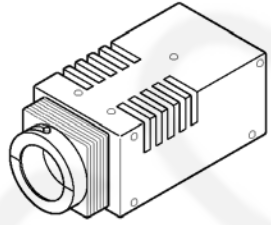
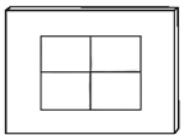
7.1. Service Fixture and Tools

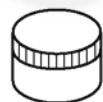
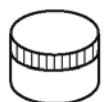
The following Service Fixture and tools are used for checking and servicing this unit.

Resistor for Discharging ERG5SJ102	Infinity Lens (with Focus Chart) VFK1164TCM02	LIGHT BOX VFK1164TDVLB
 <p>An equivalent type of Resistor may be used.</p>		 <p>※ with DC Cable</p>
TR Chart VFK1975	Lens Cleaning Kit (BK) VFK1900BK	Grease (for lens) VFK1829
	 <p>* Only supplied as 10 set/box.</p>	
Furoyl grease (for focus motor) VFK1850	T6 Trox driver VFK1981	
		

7.2. When Replacing the Main PCB

After replacing the MAIN PCB, be sure to achieve adjustment.

The adjustment instruction is available at "software download" on the "Support Information from NWBG-PAVC" web-site in "TSN system", together with Maintenance software.

7.3. Service Position

This Service Position is used for checking and replacing parts. Use the following Extension cables for servicing.

Table S1 Extension Cable List

No.	Parts No.	Connection	Form
1	VFK1976	FP9007 (MAIN) - TOP OPERATION UNIT	19PIN 0.5 FFC
2	VFK1783	P9004 (MAIN) - HOT SHOE UNIT	2PIN CABLE
3	VFK1980	P9002 (MAIN) - EVF UNIT	2PIN CABLE
4	VFK1461	FP9005 (MAIN) - EVF UNIT	20PIN 0.5 FFC
5	VFK1492	FP9004 (MAIN) - LCD HINGE UNIT	26PIN 0.5 FFC
6	VFK1576DC202	P9003 (MAIN) - FLASH SW UNIT	2PIN CABLE
7	VFK1480	FP9001 (MAIN) - MIC FPC UNIT	6PIN 0.5 FFC
8	VFK1441	FP9003 (MAIN) - SIDE OPERATION UNIT	8PIN 0.5 FFC
9	VFK1951	FP9008 (MAIN) - LENS FPC UNIT	39PIN 0.3 FFC
10	VFK1174	FP9002 (MAIN) - CCD UNIT	30PIN 0.5 FFC
11	VFK1576DC202	P9001 (MAIN) - AF ASSIST PCB	2PIN CABLE
12	VFK1576DSC03	P9006 (MAIN) - BATTERY CATCHER UNIT	3PIN CABLE
13	VFK1582A1225	FP9006 (MAIN) - FP8101 (FLASH)	12PIN 0.5 FFC
14	VFK1576DSC03	P9001 (FLASH) - FLASH UNIT	2PIN CABLE
15	VFK1576DC202	P9002 (FLASH) - FLASH UNIT	2PIN CABLE

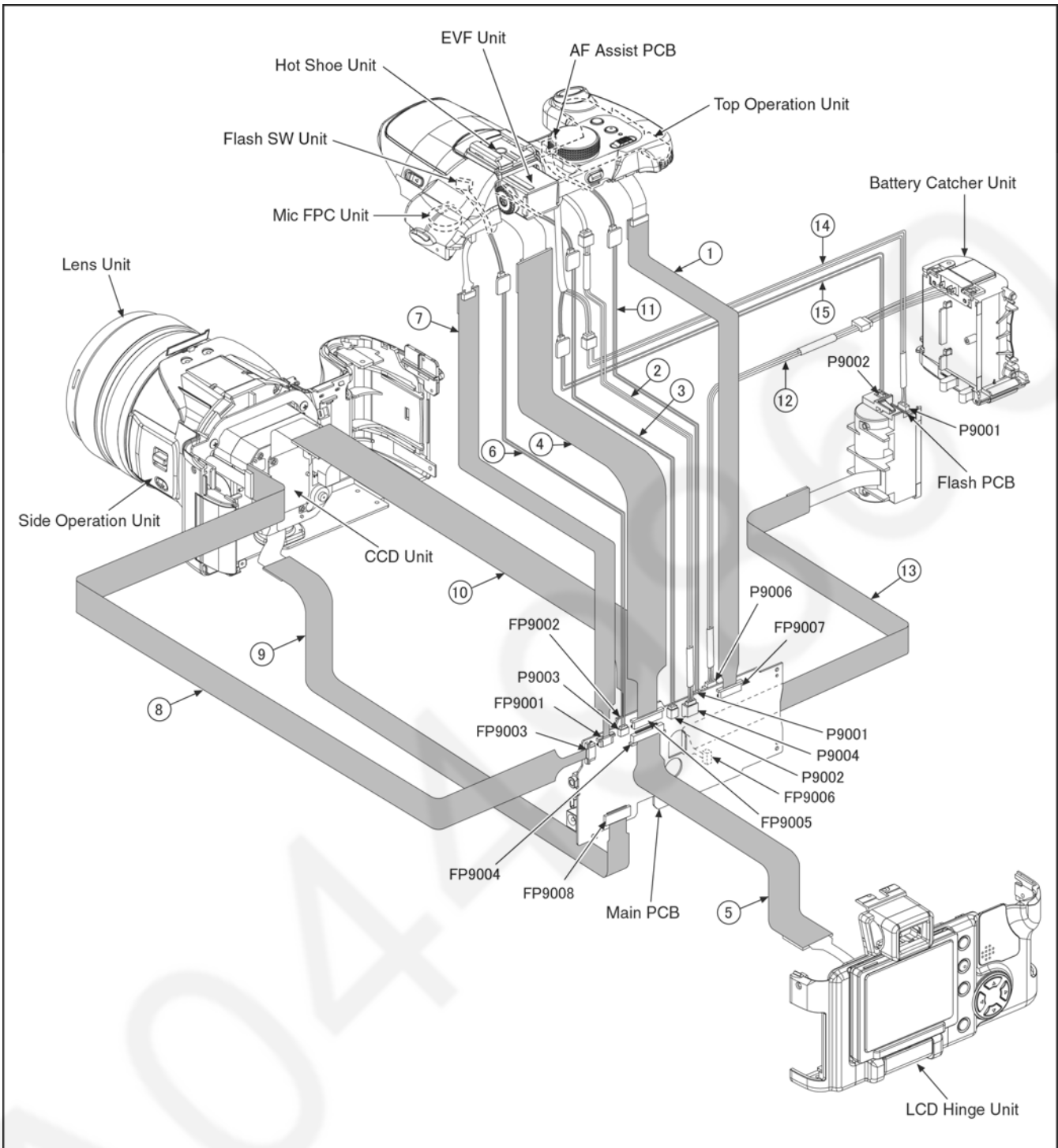

CAUTION-1. (When servicing FLASH PCB)

1. Be sure to discharge the capacitor on FLASH PCB.
Refer to "HOW TO DISCHARGE THE CAPACITOR ON FLASH PCB".
The capacitor voltage is not lowered soon even if the AC Cord is unplugged or the battery is removed.
2. Be careful of the high voltage circuit on FLASH PCB.
3. DO NOT allow other parts to touch the high voltage circuit on FLASH PCB.

8 Disassembly and Assembly Instructions

8.1. Disassembly Flow Chart

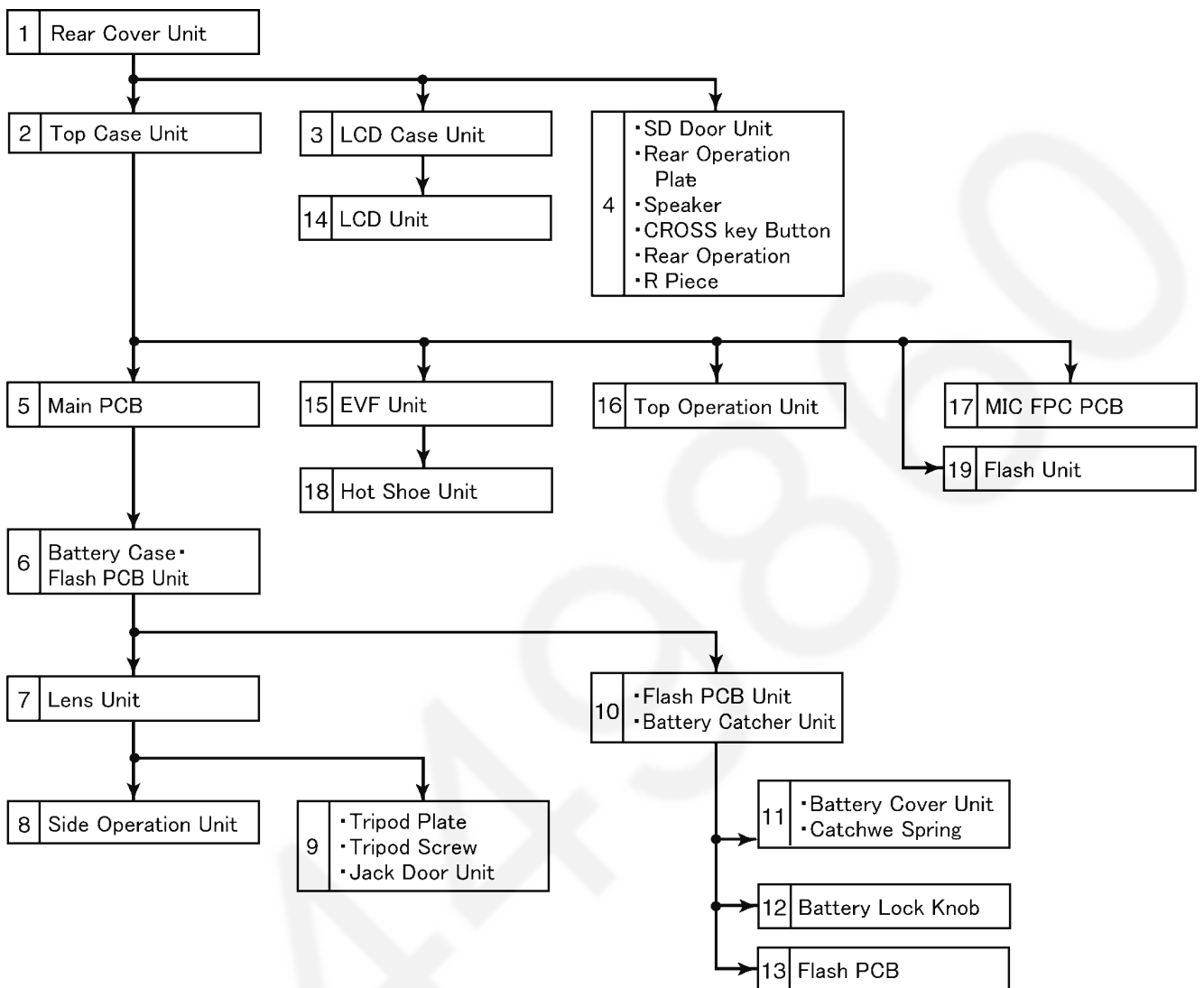

8.2. PCB Location

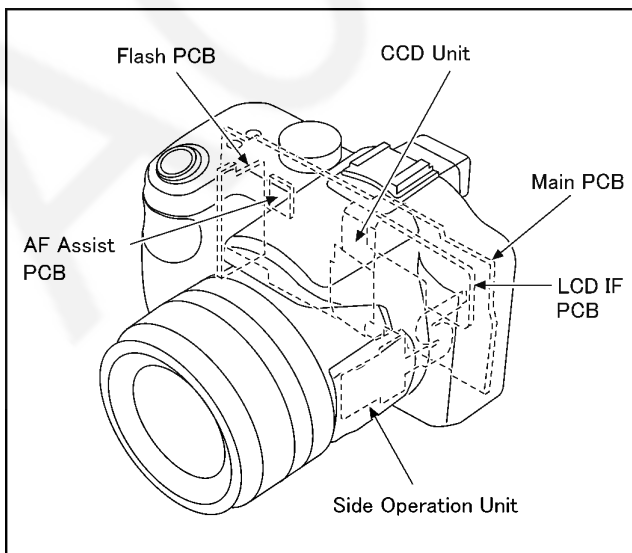

8.3. Disassembly Procedure

No.	Item	Fig	Removal
1	Rear Cover Unit	Fig. D1	Card
			Battery
			2 Screws (A)
			6 Screws (B)
			2 Screws (C)
			Shoe Spring
		Fig. D2	FP9004(Flex) Rear Cover Unit
2	Top Case Unit	Fig. D3	4 Screws (D)
		Fig. D4	1 Screw (D)
			FP9001(Flex)
			P9003(Connector)
			FP9005(Flex)
			P9002(Connector)
			P9004(Connector)
			FP9007(Flex)
			P9001(Connector)
			P9006(Connector)
			P9002(Connector)
			P9001(Connector)
			Top Case Unit
			3
4 Locking tabs			
LCD FPC Plate			
FPC Rubber			
LCD SW Knob			
Hinge Arm Cover			
2 Locks			
LCD Case Unit			
4	SD Door Unit Rear Operation Plate Speaker CROSS Key Button Rear Operation R Piece	Fig. D6	1 Screw (F)
			3 Screw (G)
			SD Door Unit
			Rear Operation Plate
			Speaker
			CROSS Key Button
			Rear Operation
			R Piece
5	Battery Case Flash PCB Unit	Fig. D7	1 Screw (H)
			2 Screws (I)
			FP9002(Flex)
			FP9008(Flex)
			FP9006(Flex) Main PCB
6	Main C.B.A.	Fig. D8	1 Screw (J)
			Battery Case Flash PCB Unit
7	Lens Unit	Fig. D9	4 Screws (K)
			Lens Unit
8	Side Operation Unit	Fig. D10	2 Screws (L)
			Side Operation Unit
9	Tripod Plate Tripod Screw Jack Door Unit	Fig. D11	3 Screws (M)
			1 Locking tab
			Tripod Plate
			Tripod Screw Jack Door Unit
10	Flash PCB Unit Battery Catcher Unit	Fig. D12	1 Screw (N)
			2 Locking tabs
			Flash PCB Unit
			Battery Catcher Unit

No.	Item	Fig	Removal
11	Battery Cover Unit Catcher Spring	Fig. D13	Battery Cover Hinge Spring
			Battery Cover Hinge Shaft
			Battery Cover Unit
			Catcher Spring
12	Battery Lock Knob	Fig. D14	Battery Lock Shaft
			Battery Lock Spring
			Battery Lock Knob
13	Flash PCB	Fig. D15	2 Locking tabs
			Flash PCB
14	LCD Unit	Fig. D16	3 Screws (O)
			6 Locking tabs
			LCD Case Bottom
			FP4901(Flex)
			FP4902(Flex)
			FP4903(Flex)
			LCD Hinge Unit
			LCD PCB
		LCD Unit	
		Fig. D17	LCD Shield LCD Case Unit
15	EVF Unit	Fig. D18	2 Screws (P)
			EVF Unit
16	Top Operation Unit	Fig. D19	5 Screws (Q)
			Top Operation Unit
17	Mic FPC PCB	Fig. D20	2 Screws (R)
			Strap Holder R
			Mic Dumper Holder
			Mic Dumper
			2 Locks
			Mic FPC PCB
18	Hot Shoe Unit	Fig. D21	2 Screws (S)
			Hot Shoe Unit
19	Flash Unit	Fig. D22	2 Screws (T)
			4 Locking tabs
			Flash Case top
			Flash Unit

8.3.1. Removal of the Rear Cover Unit

NOTE:

When servicing and reassembling, remove the card and battery from the unit.

- Card
- Screw (A) × 2
- Screw (C) × 2
- Battery
- Screw (B) × 6
- Shoe Spring

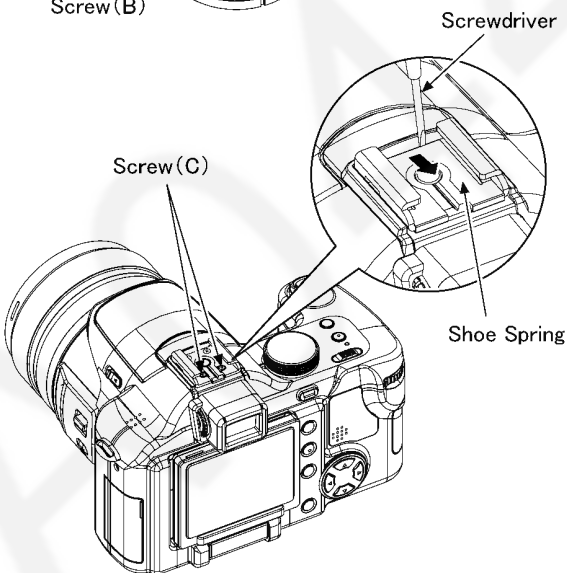
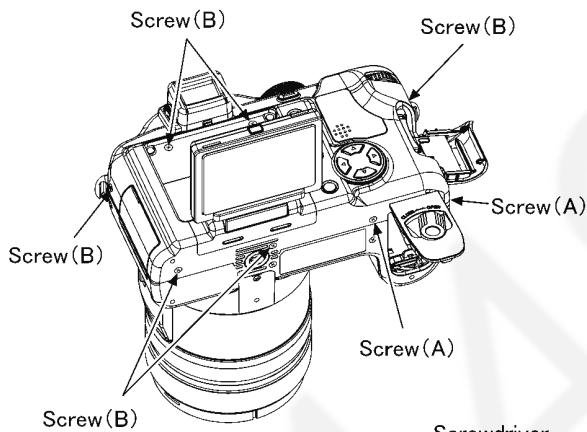
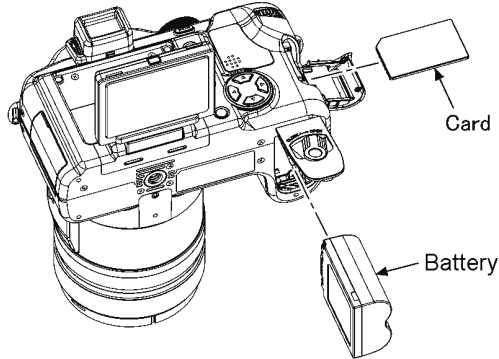



Screw (A)	Screw (B)	Screw (C)
 6mm	 4mm	 4mm
Ⓢ: SILVER Ⓚ: BLACK	Ⓢ: SILVER Ⓚ: BLACK	Ⓢ: SILVER Ⓚ: BLACK

Fig. D1

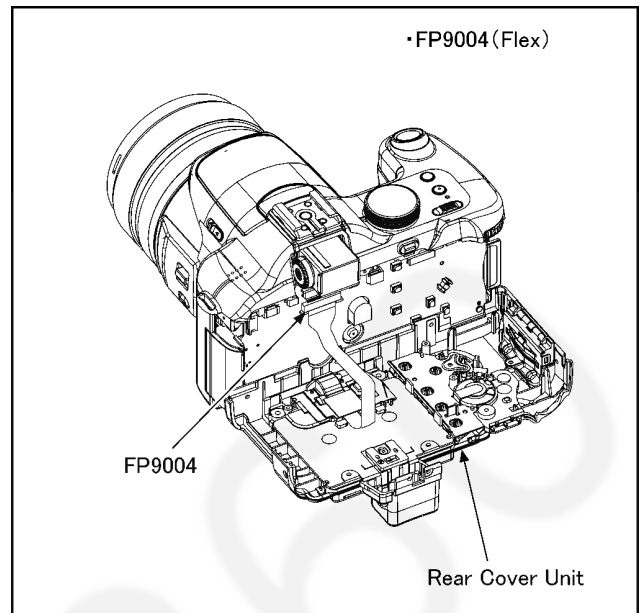

Fig. D2

8.3.2. Removal of the Top Case Unit

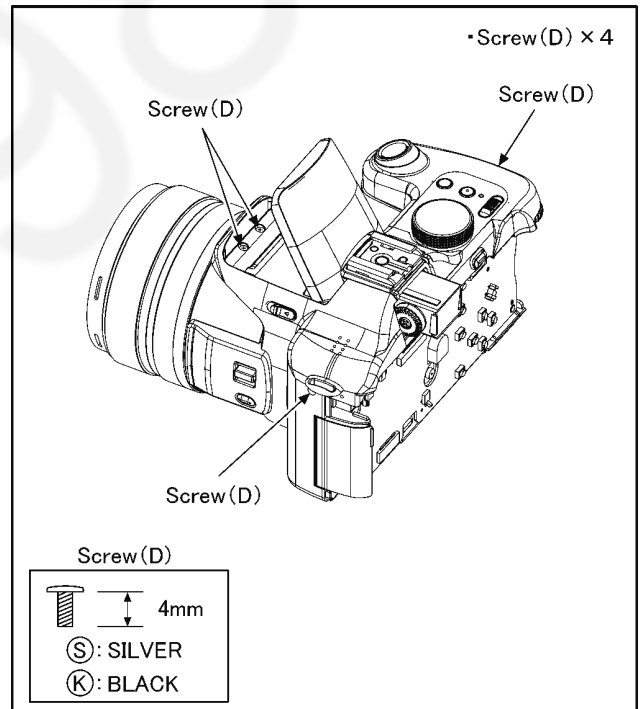

Fig. D3

8.3.3. Removal of the LCD Case Unit

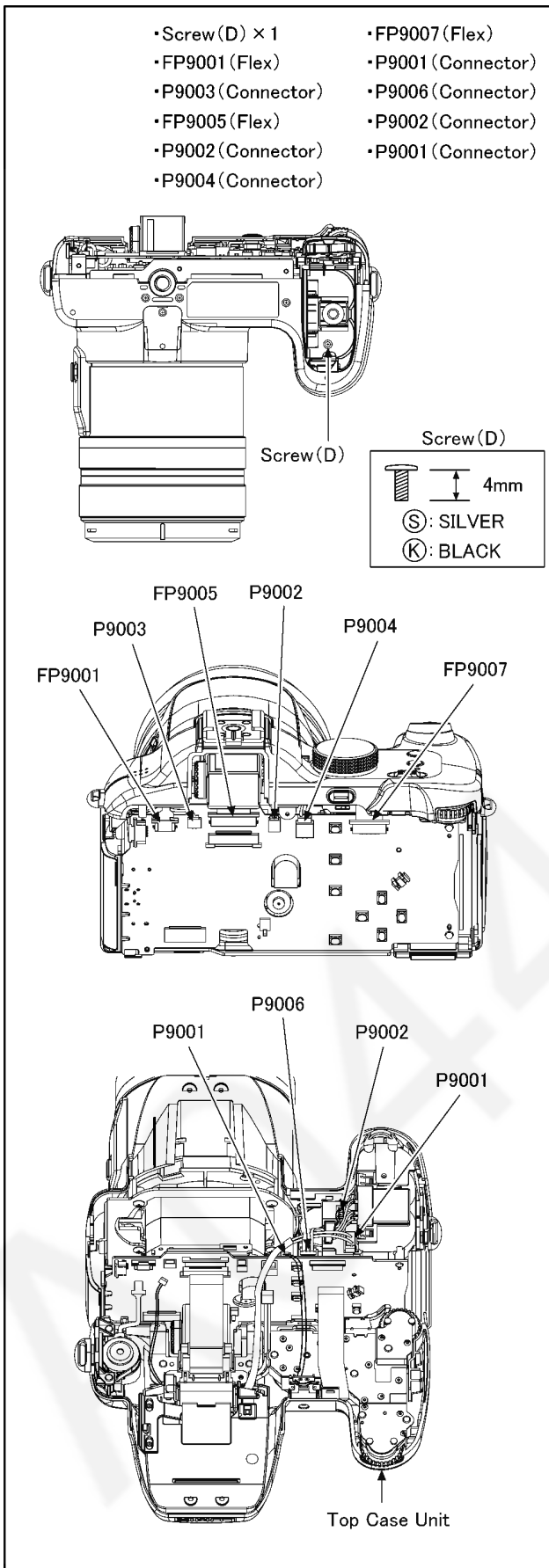

Fig. D4

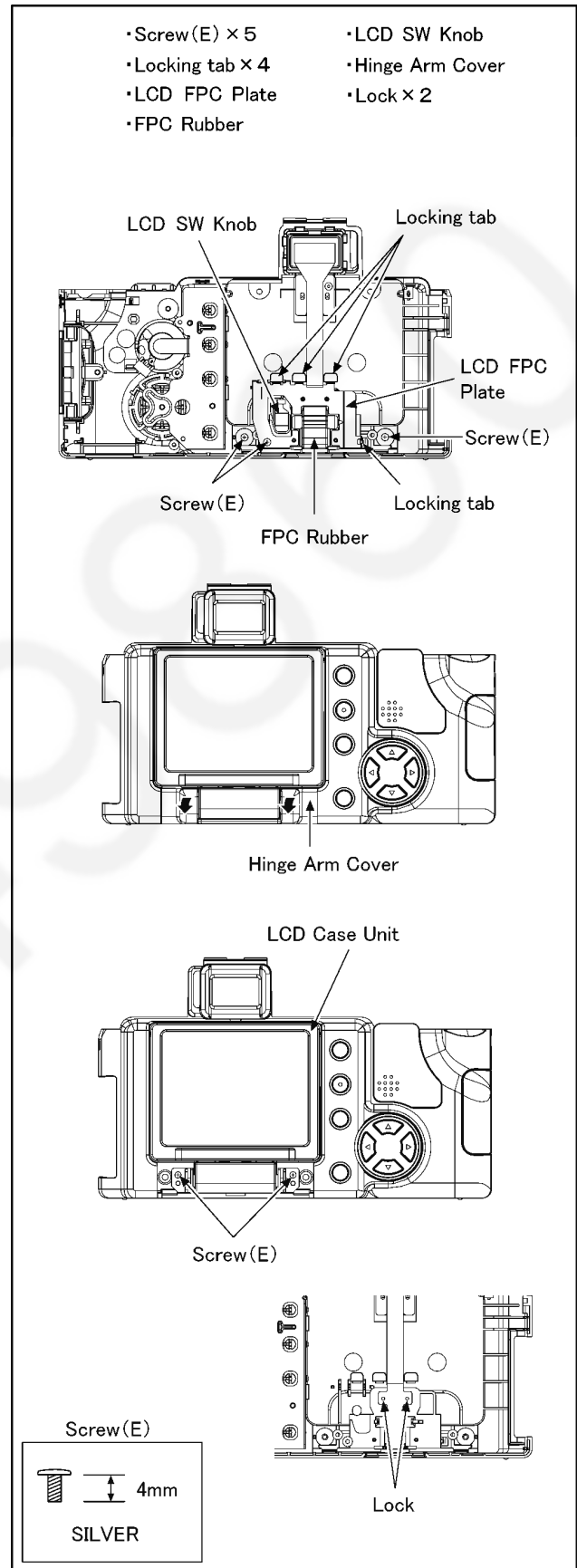

Fig. D5

8.3.4. Removal of the SD Door Unit, Rear Operation Plate, Speaker, CROSS Key Button, Rear Operation Unit and R Piece

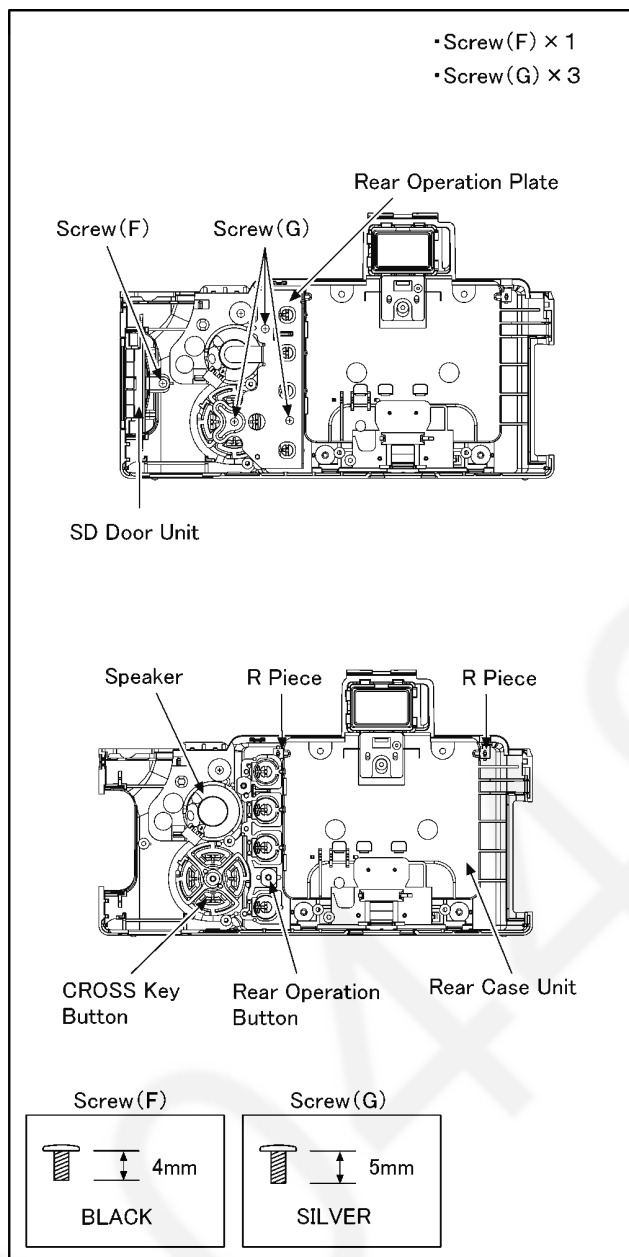

Fig. D6

8.3.5. Removal of the Main PCB

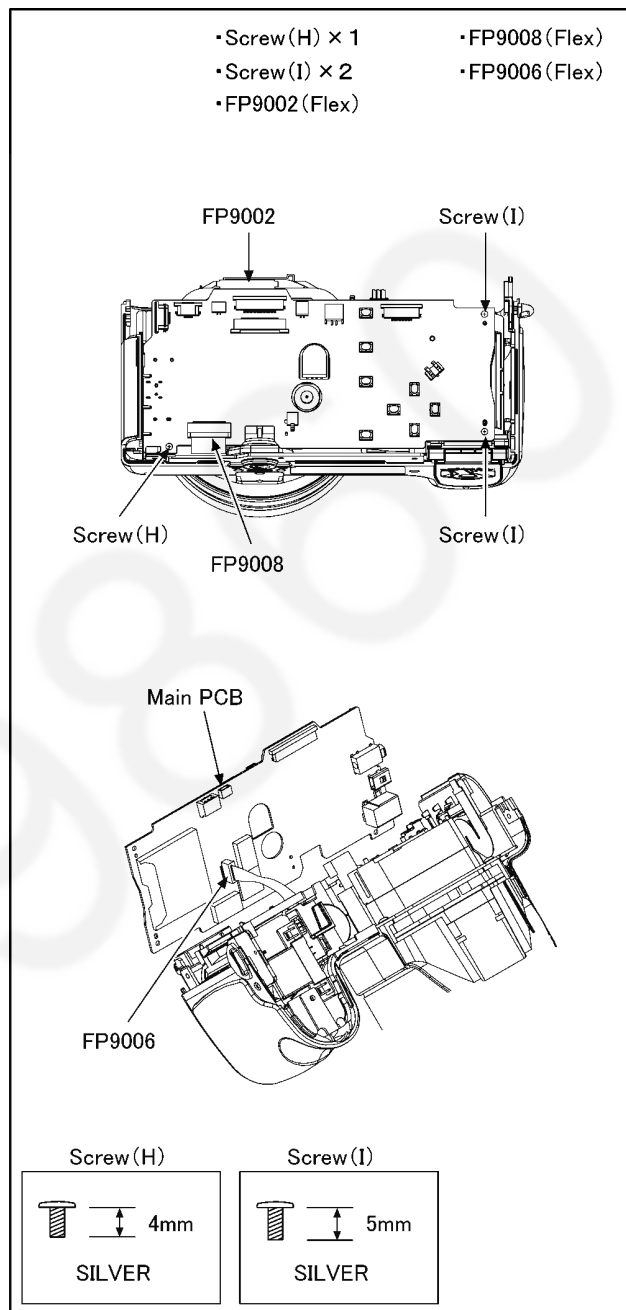

Fig. D7

8.3.6. Removal of the Battery Case and Flash PCB Unit

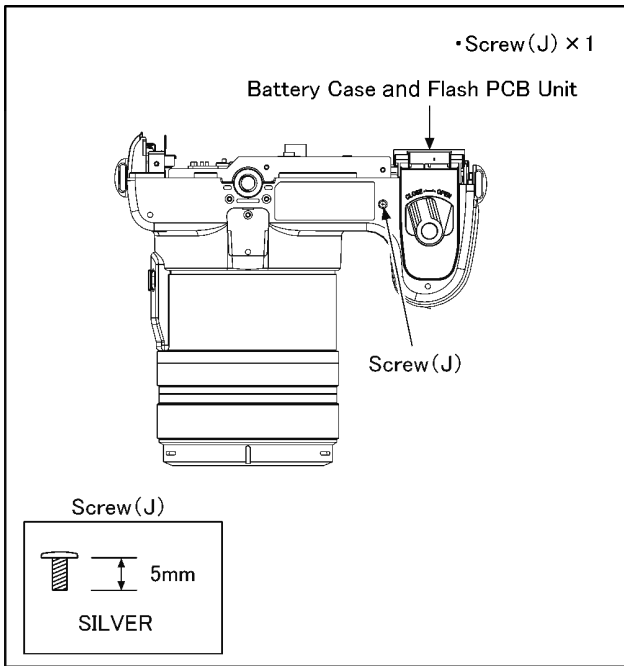

Fig. D8

8.3.7. Removal of the Lens Unit

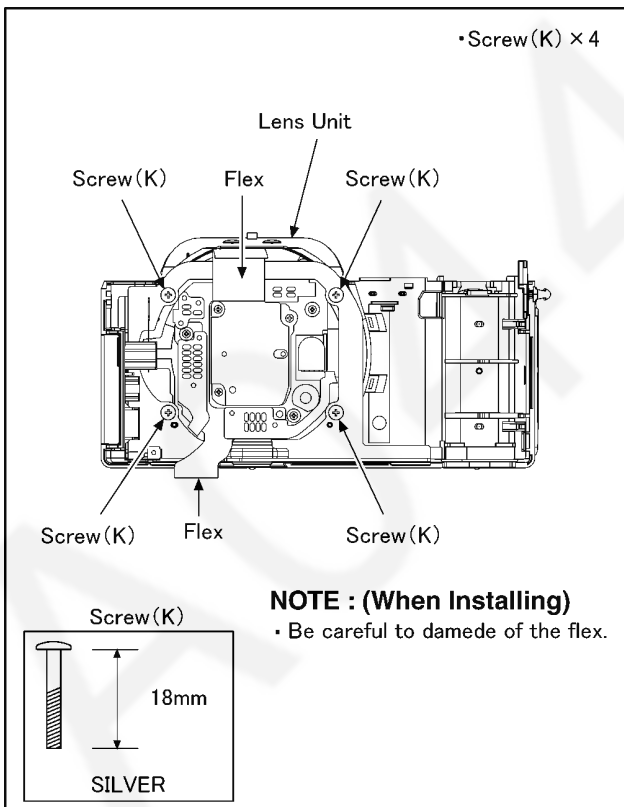

Fig. D9

8.3.8. Removal of the Side Operation Unit

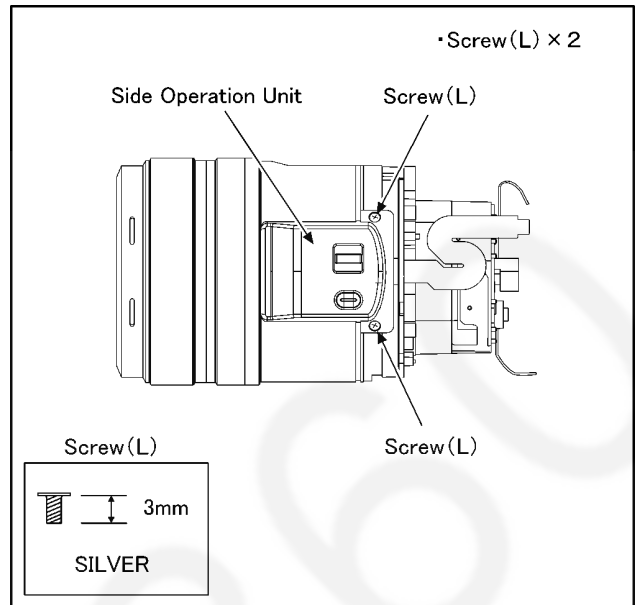

Fig. D10

8.3.9. Removal of the Tripod Plate, Tripod Screw and Jack Door Unit

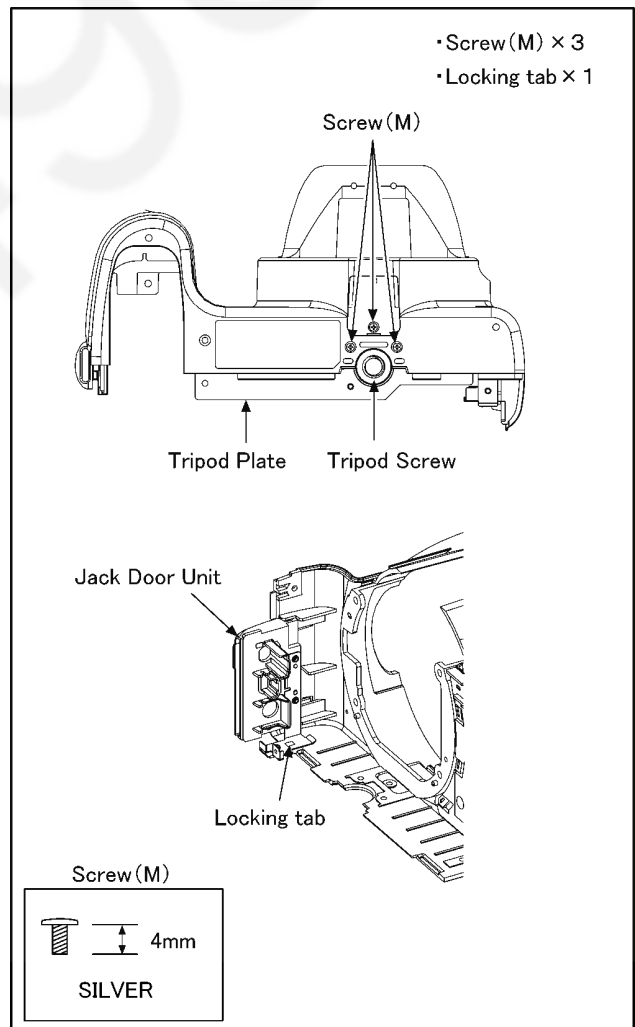

Fig. D11

8.3.10. Removal of the Flash PCB Unit and Battery Catcher Unit

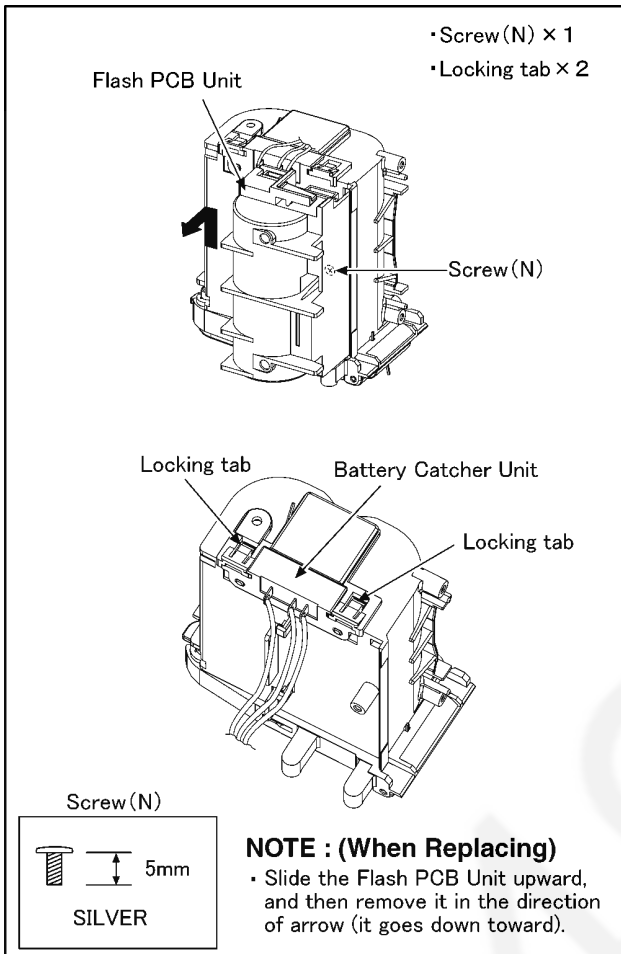

Fig. D12

8.3.11. Removal of the Battery Cover Unit and Catchier Spring

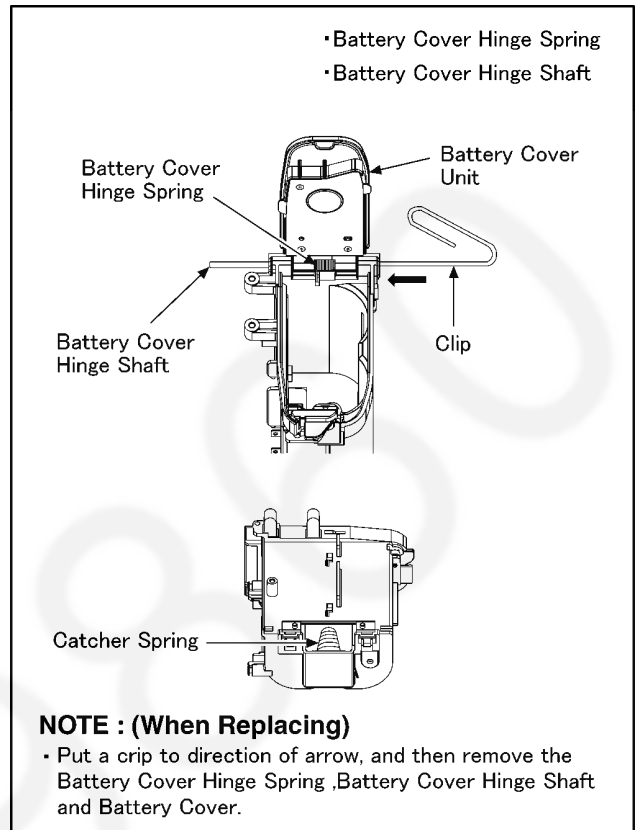

Fig. D13

8.3.12. Removal of the Battery Lock Knob

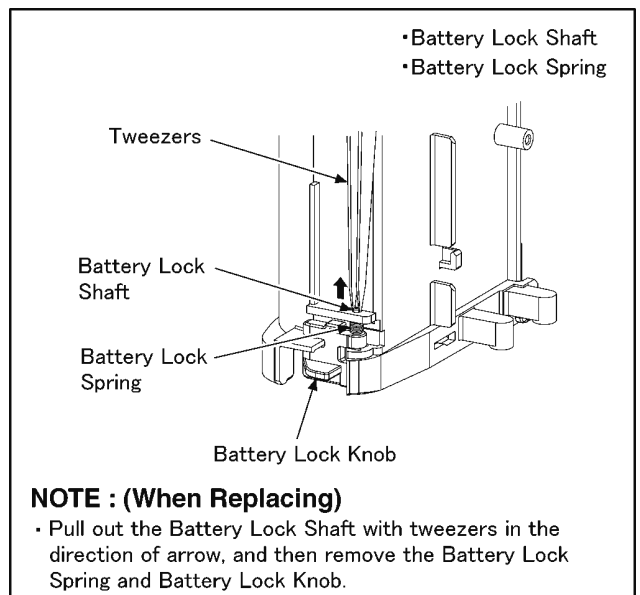

Fig. D14

8.3.13. Removal of the Flash PCB

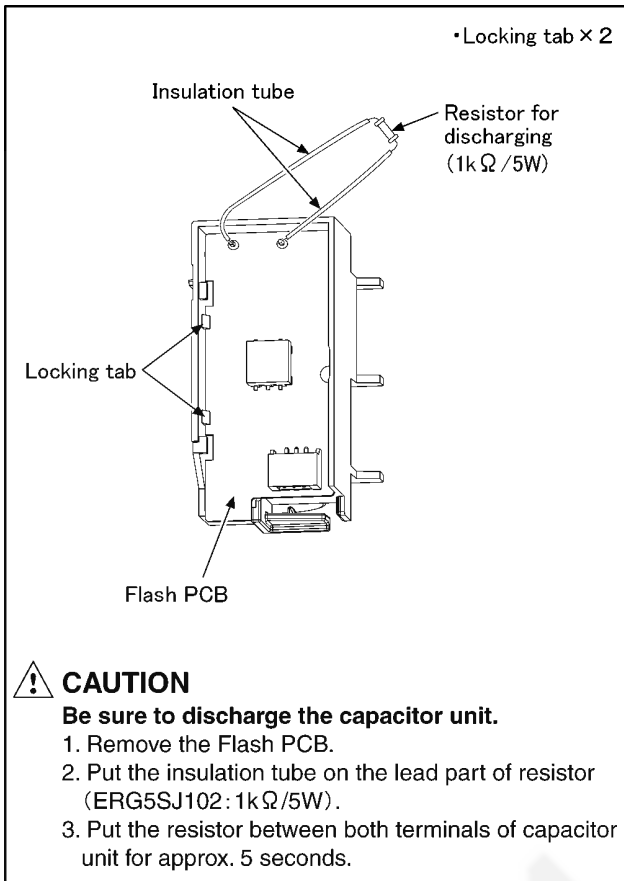

Fig. D15

8.3.14. Removal of the LCD Unit

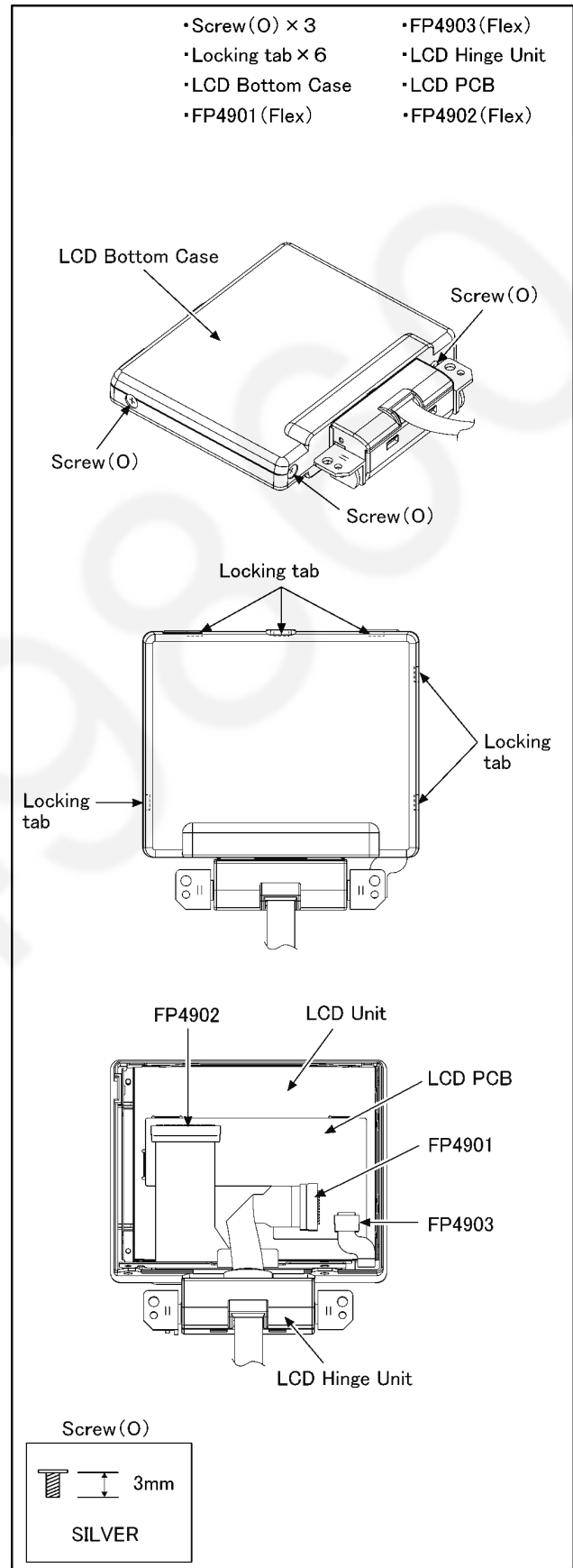

Fig. D16

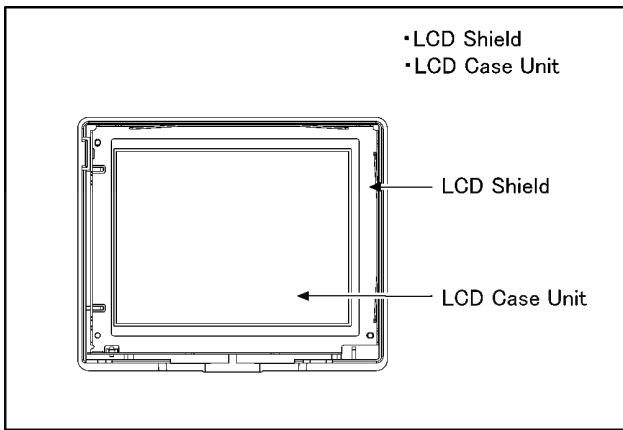

Fig. D17

8.3.15. Removal of the EVF Unit

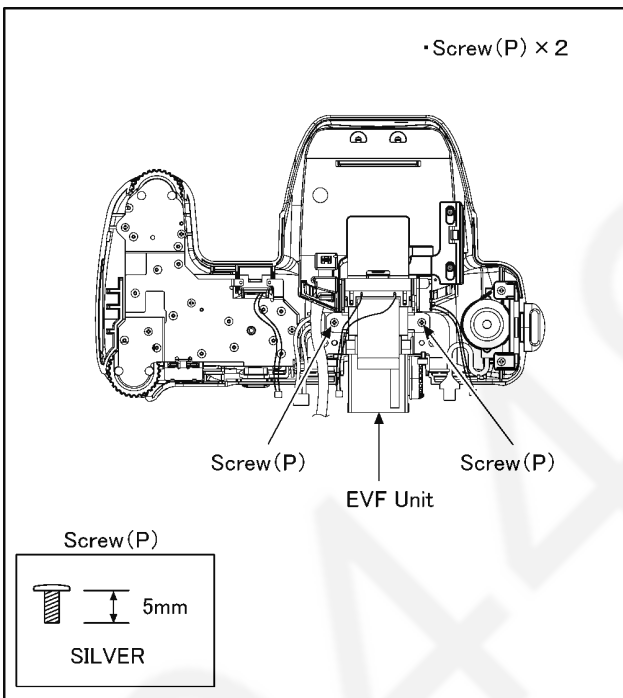

Fig. D18

8.3.16. Removal of the Top Operation Unit

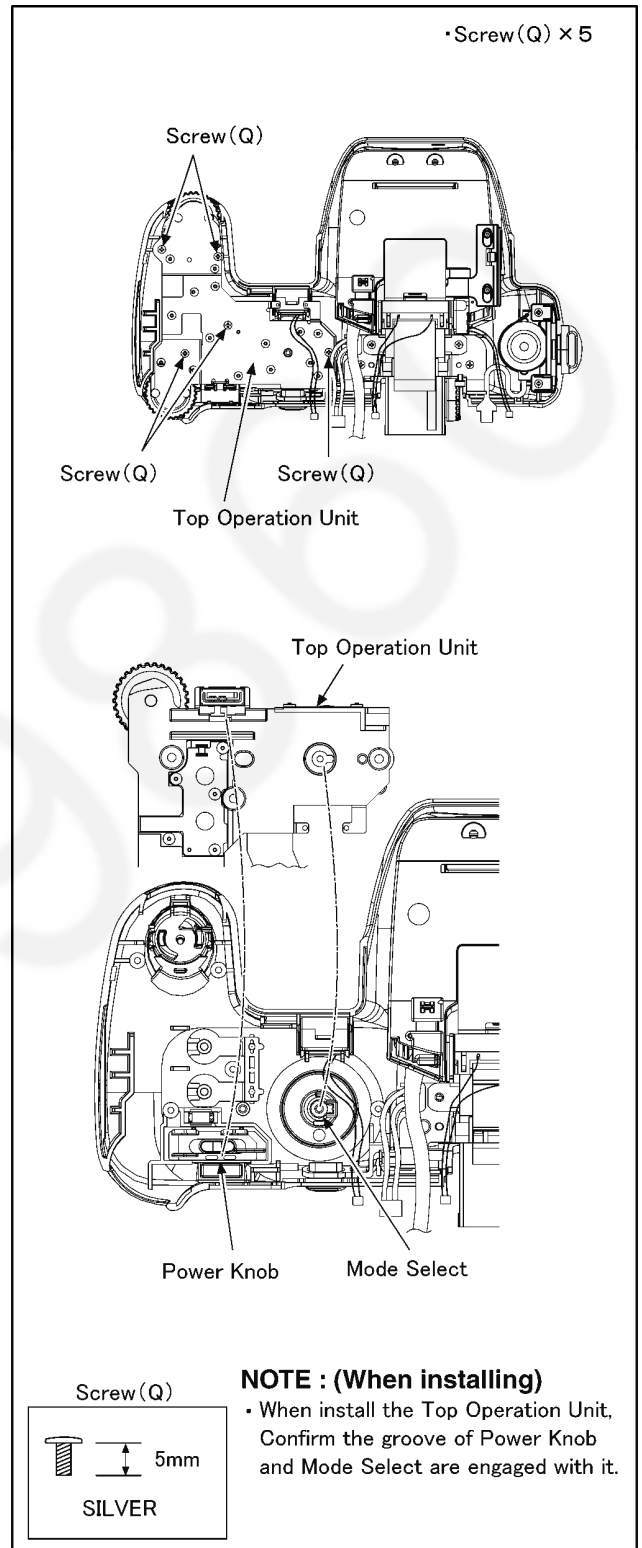

Fig. D19

8.3.17. Removal of the Mic FPC PCB

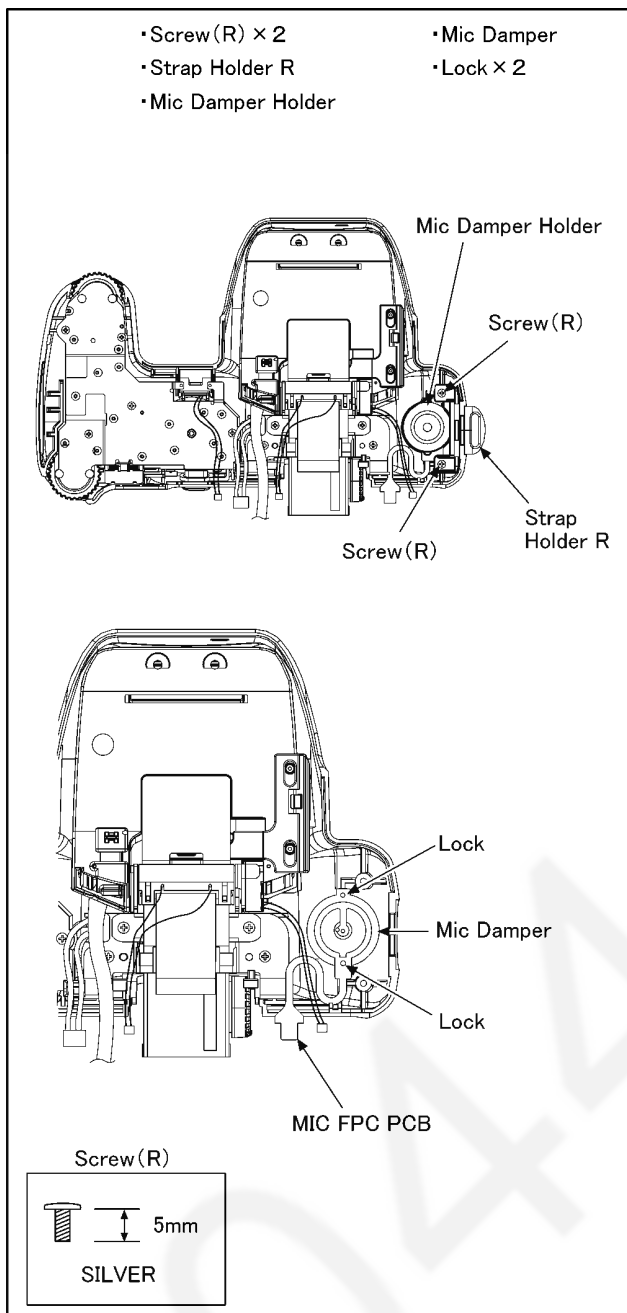

Fig. D20

8.3.18. Removal of the Hot Shoe Unit

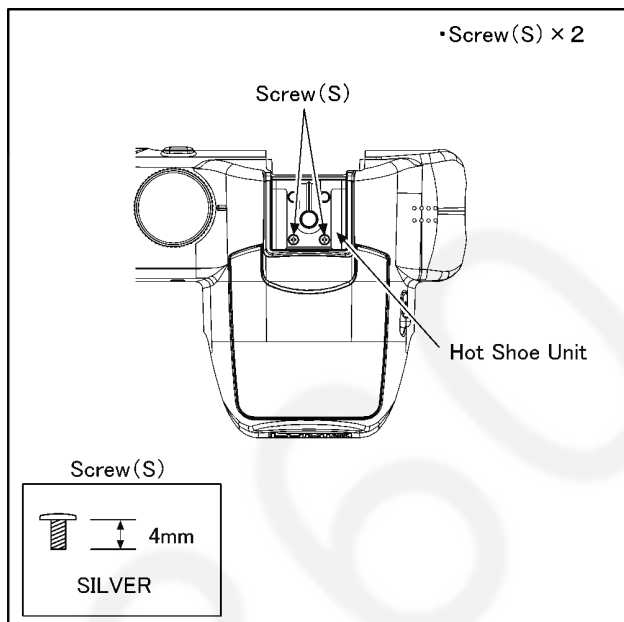

Fig. D21

8.3.19. Removal of the Flash Unit

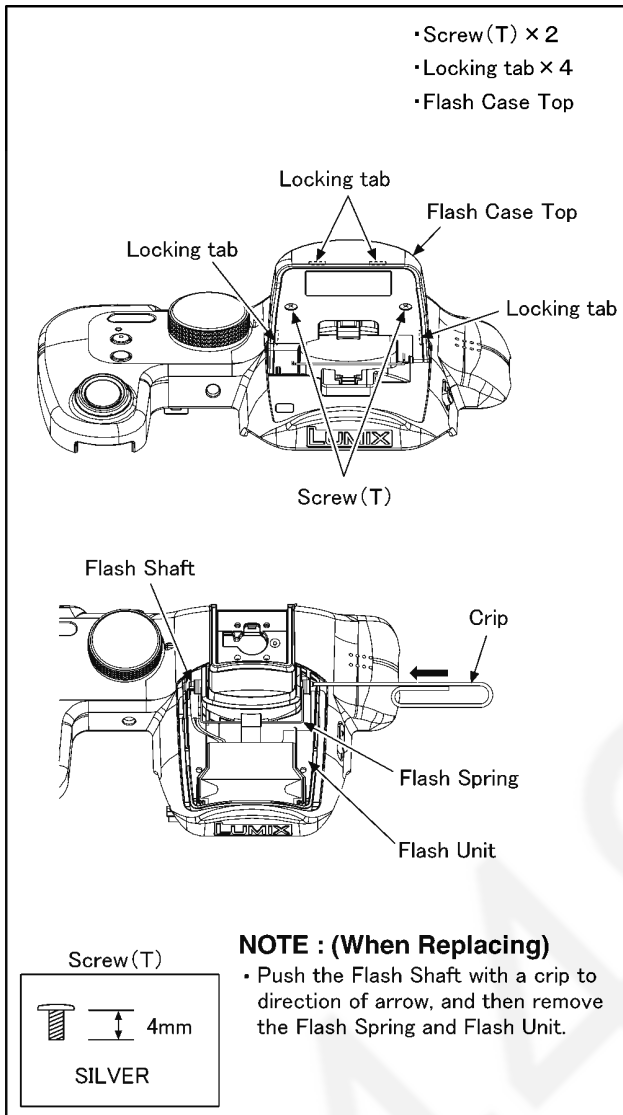

Fig. D22

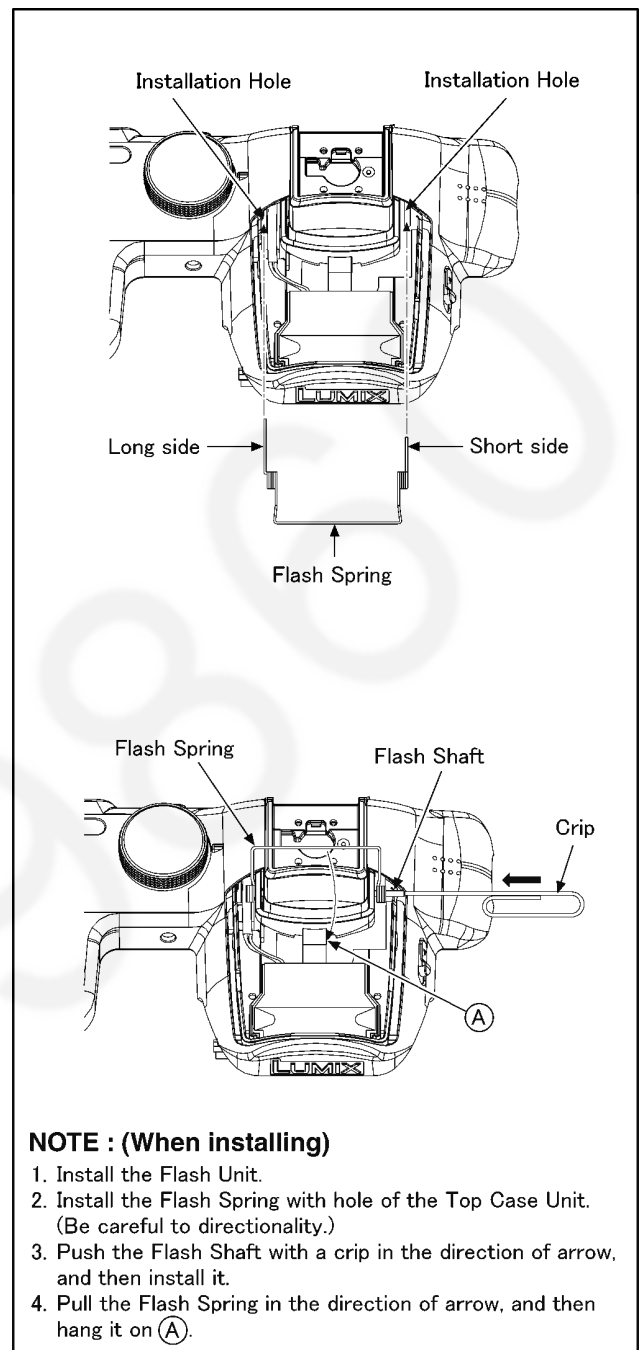

Fig. D23

NOTE: (When Assembling)

Confirm the contents as shown below.

- Condition of the screw is tightened.
- Assembling condition of mechanism parts (distortion, space etc.)
- Dust and dirt of the lens, display condition of the LCD (gradient etc.)
- Dust and dirt of the LCD

8.4. Disassembly Procedure for the Lens

NOTE: When Disassembling and Assembling for the Lens

- To prevent the lens from catching the dust and dirt, perform the following procedures with the CCD unit is installing.
Disassembling procedures for the CCD unit, refer to item 8.6.
- Take care that the dust and dirt are not entered into the lens.
In case of the dust is putted on the lens, blow off them by airbrush.
- Do not touch the surface of lens.
- Use lens cleaning KIT (BK)(VFK1900BK).
- Apply the grease (VFK1829) to the point where is shown to "Grease apply" in the figure.
When the grease is applied, use a toothpick and apply thinly.

8.4.1. Removal of the Lens FPC Unit

- Remove the solders (4 points).
- Remove the lock (8 points).
- Unscrew the 4 screws (A).
- Remove the Lens FPC unit.

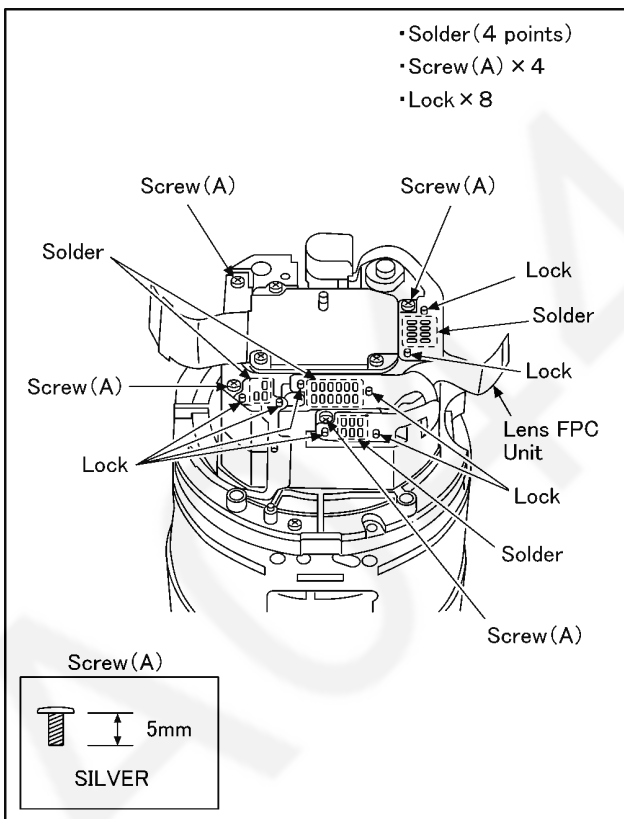

8.4.2. Removal of the Decoration Ring

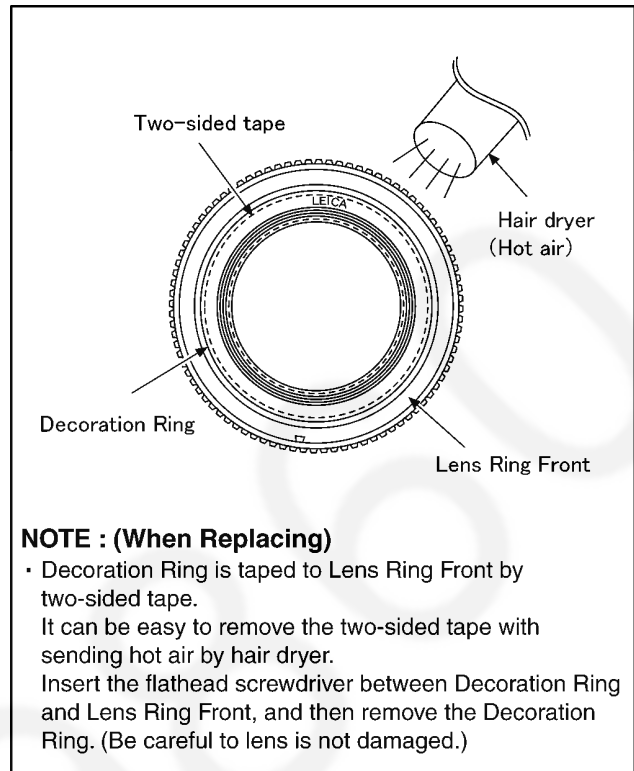

8.4.3. Removal of the Lens Ring Front and Zoom Ring Unit

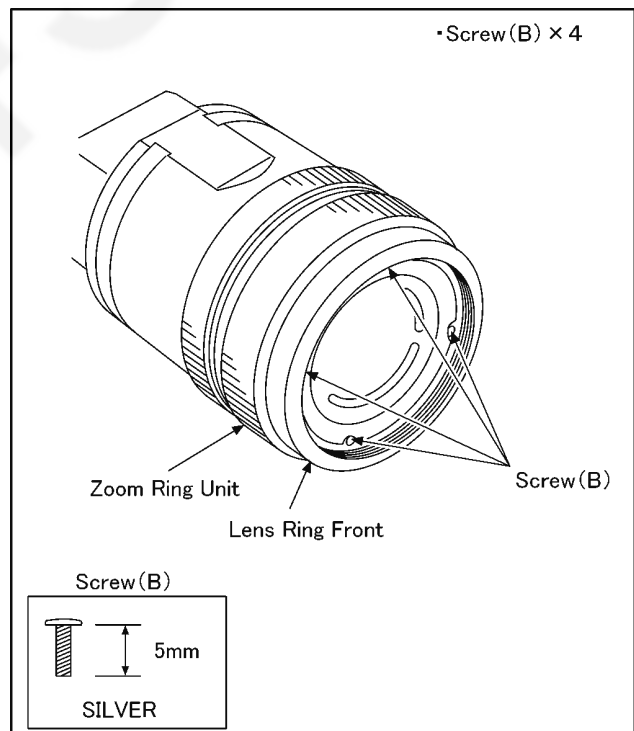

8.4.4. Removal of the Master Flange Unit and Lens Ring Base

•Screw (C) × 3
•Locking tab × 3

Screw (C)

Screw (C)

Locking tab

Zoom Drive Pin

Locking tab

Locking tab

Master Flange Unit

Lens Ring Base

NOTE : (When Replacing)

1. Remove the 3 screws (C), the Master Flange Unit is turned counterclockwise and the unlock is Locking tab ①, and then remove it for above ②. (Confirm the Zoom Drive Pin is in the groove of the Master Flange Unit.)
2. Remove the Lens Ring Base.

Screw (C)

	8mm
SILVER	

8.4.5. Removal of the Zoom Encoder Unit

•Lock × 3
•Screw (D) × 1

Zoom Encoder Unit

Lock

Screw (D)

Lock

Lock

NOTE : (When Replacing)

- When remove the Zoom Encoder Unit, Be careful to damage of the Zoom Encoder Flex.

Screw (D)

	3mm
SILVER	

8.4.6. Removal of the Focus Motor Unit

•Screw (E) × 2
•Lock × 2

Screw (E)

Lock

Focus Motor Unit

Screw (E)

	5mm
SILVER	

8.4.7. Removal of the Master Flange

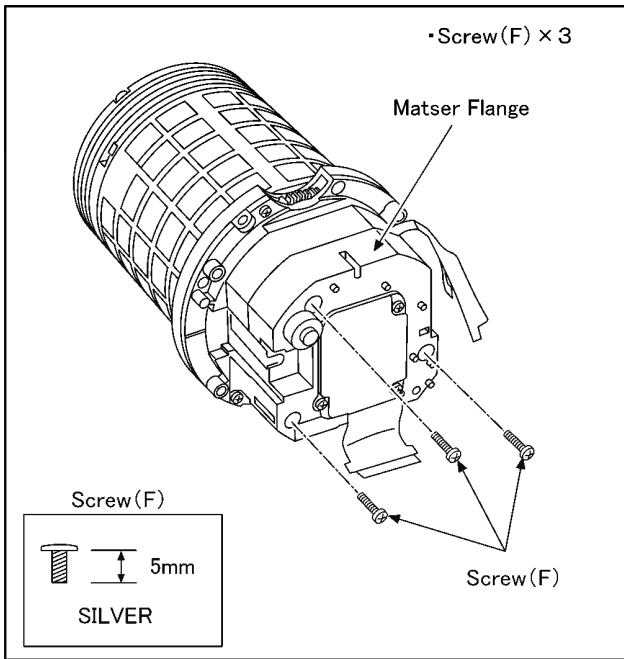

8.4.9. Removal of the Inside Frame

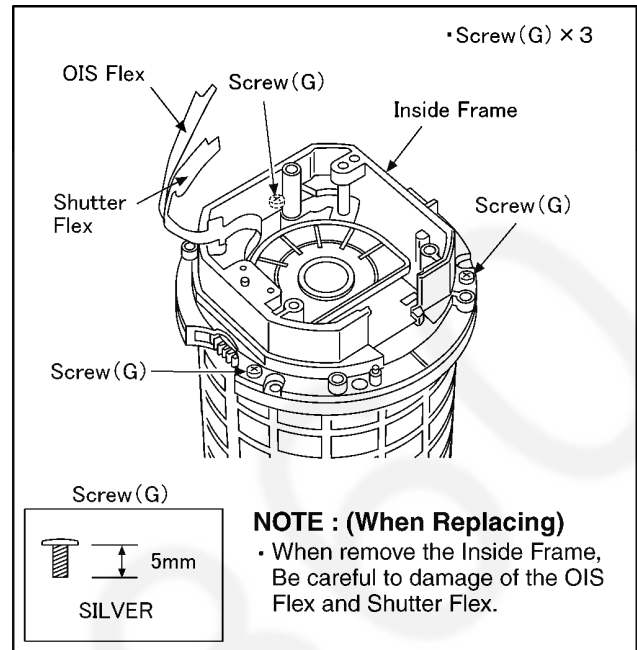

8.4.8. Removal of the 5th Lens Frame Unit and F Guide Pole L/S

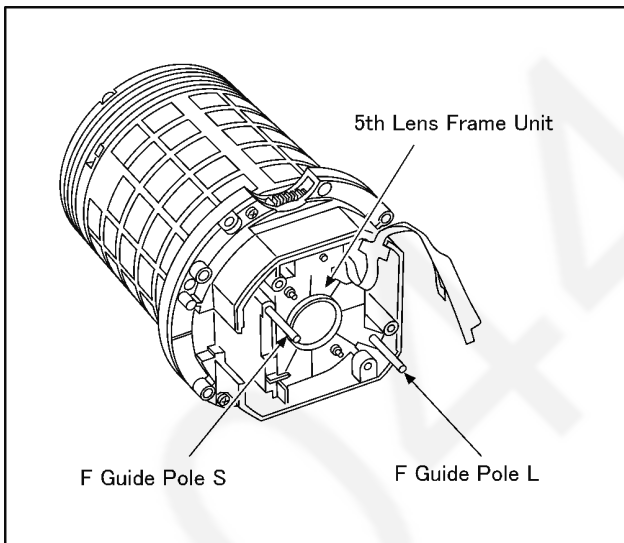

8.4.10. Removal of the 4th Lens Frame Unit

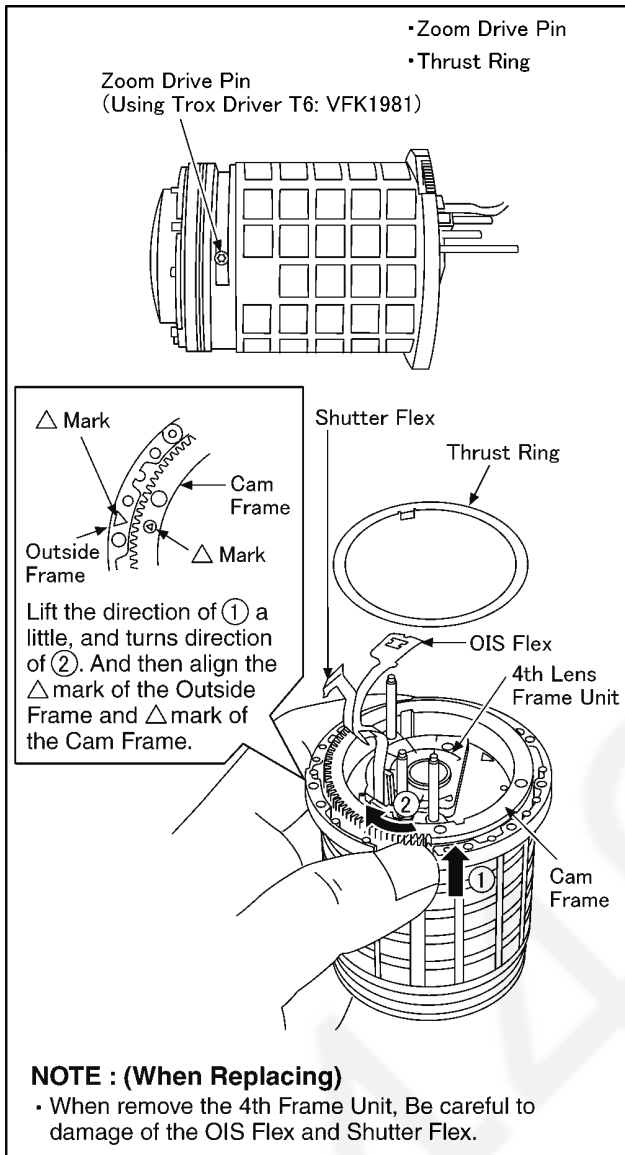

8.4.11. Removal of the 3rd Lens Frame Unit

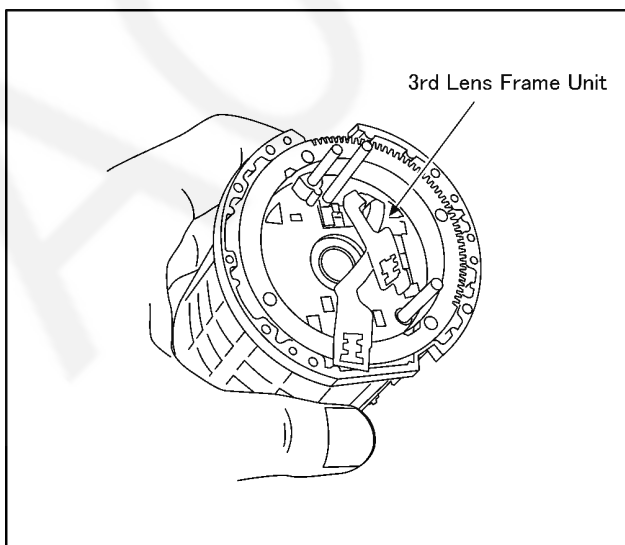

8.4.12. Removal of the 2nd Lens Frame Unit

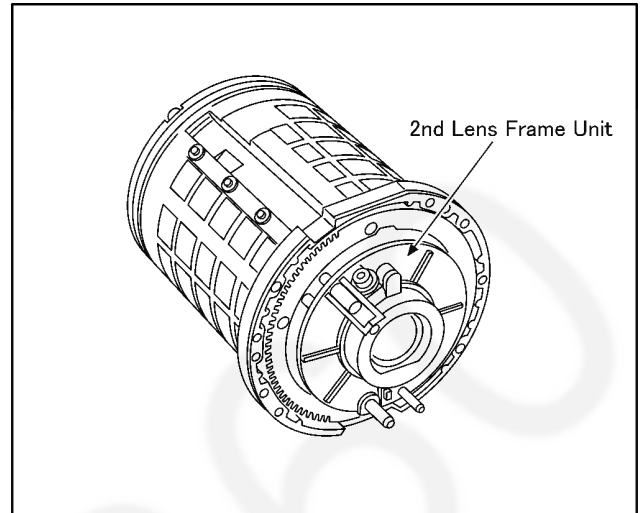

8.4.13. Removal of the Cam Frame Unit and Guide Pole

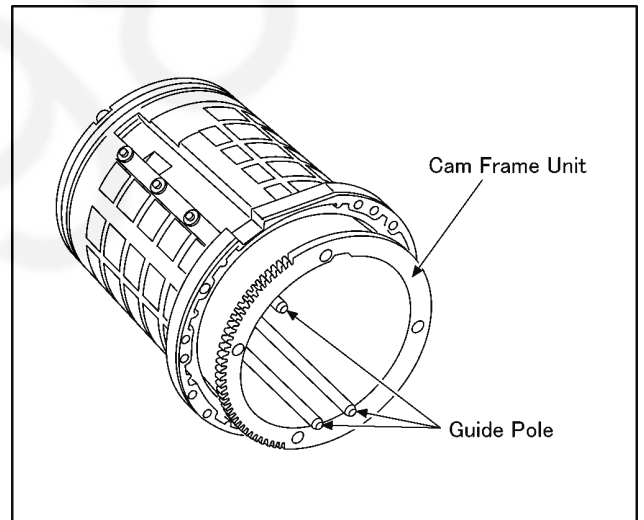

8.4.14. Removal of the 1st Lens Frame Unit

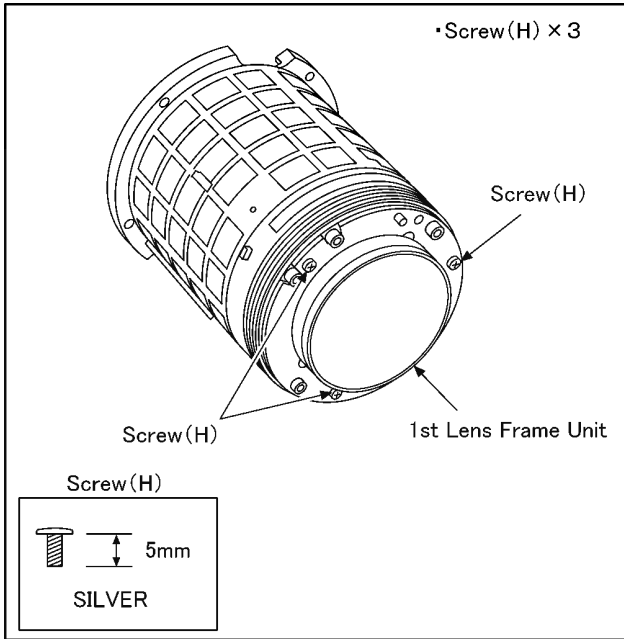

8.5. Assembly Procedure for the Lens

8.5.1. Assembly for the 1st Lens Frame Unit

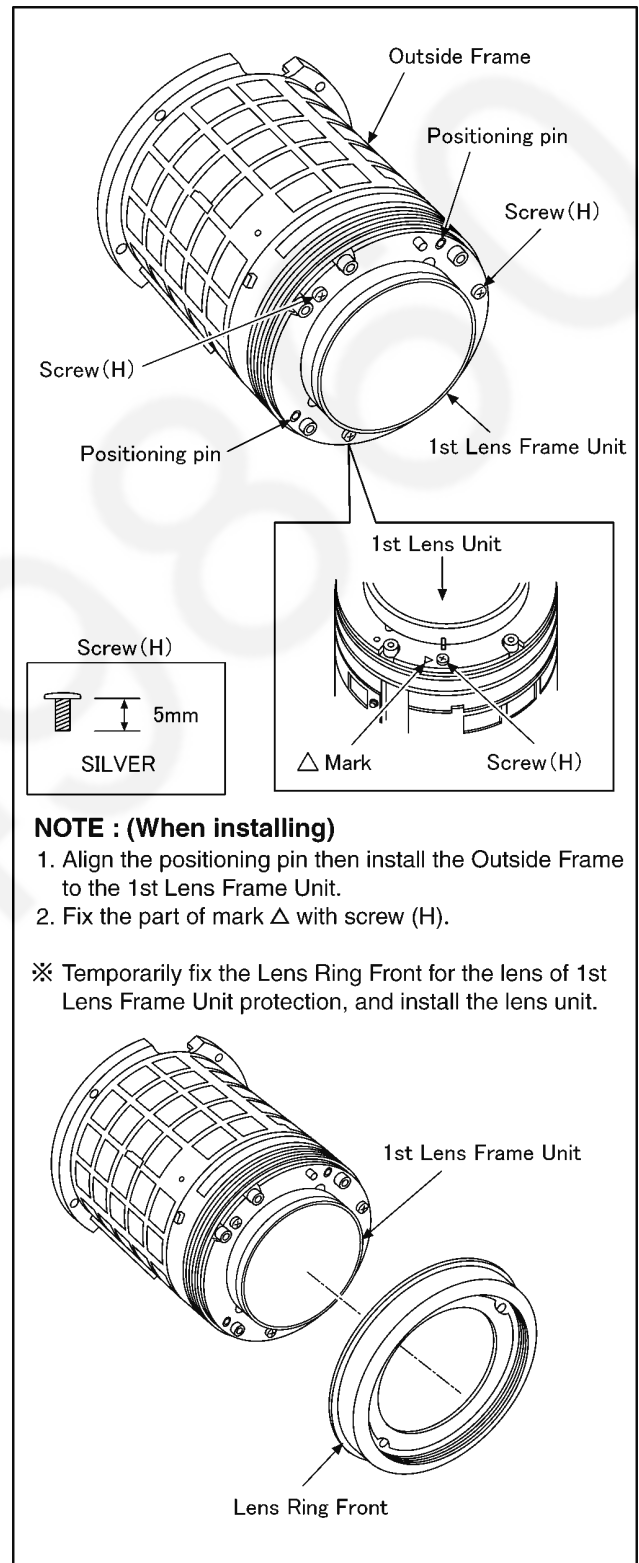

8.5.2. Assembly for the Guide Pole and Cam Frame Unit

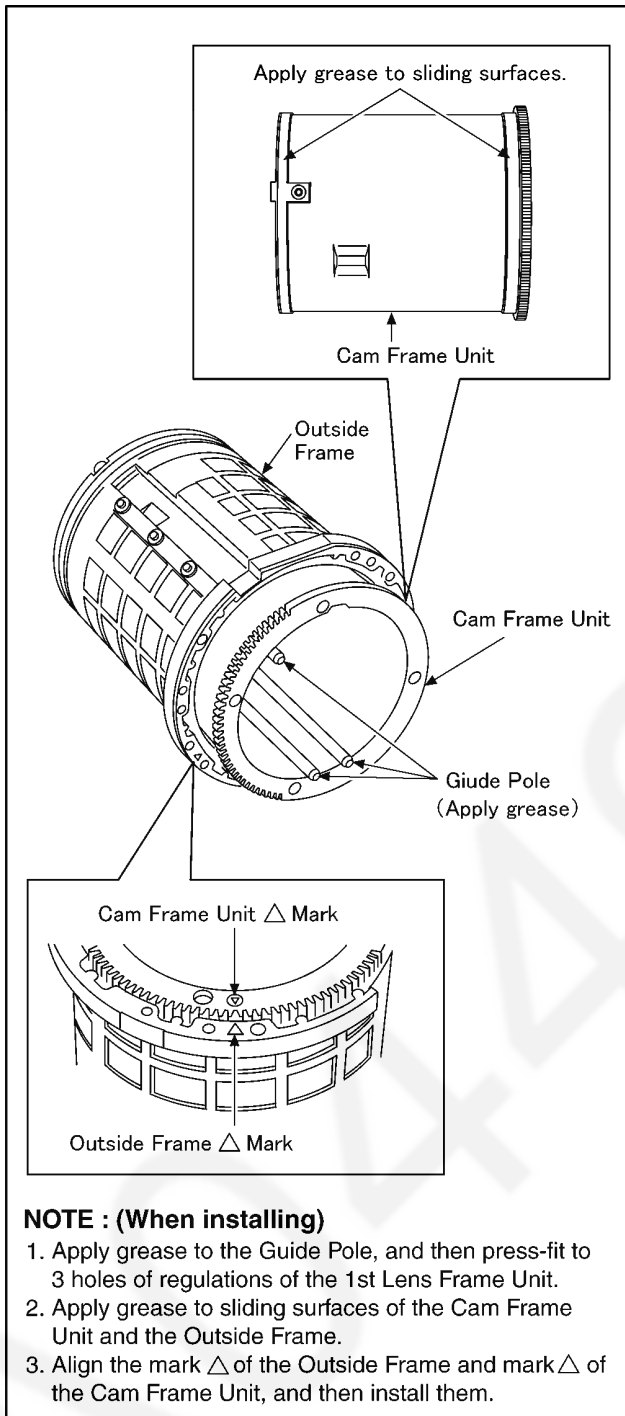

8.5.3. Assembly for the 2nd Lens Frame Unit

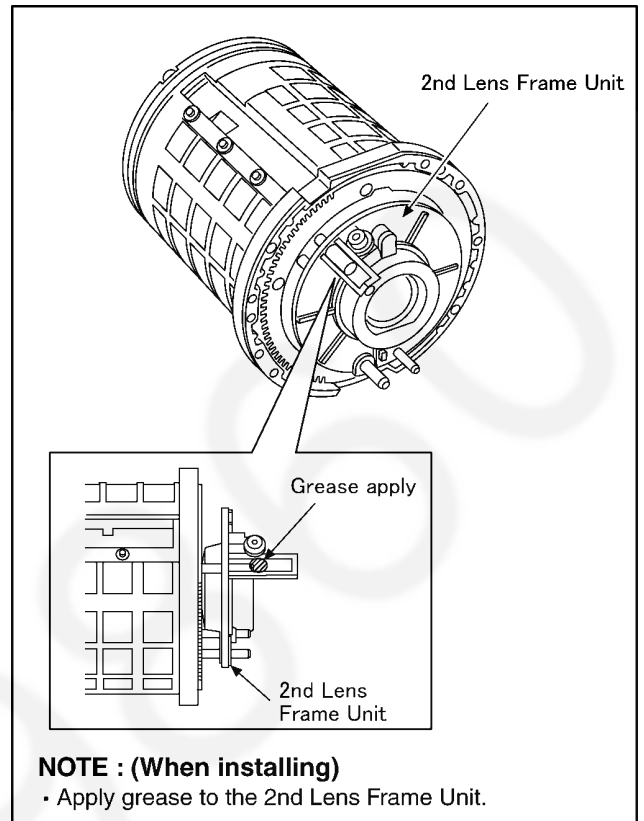

8.5.4. Assembly for the 3rd Lens Frame Unit

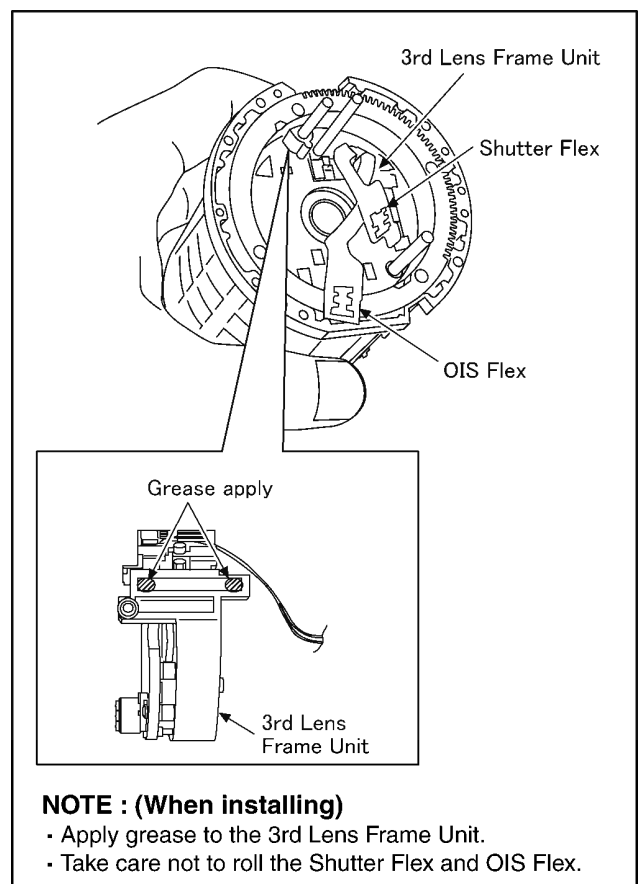

8.5.5. Assembly for the 4th Lens Frame Unit and Thrust Ring

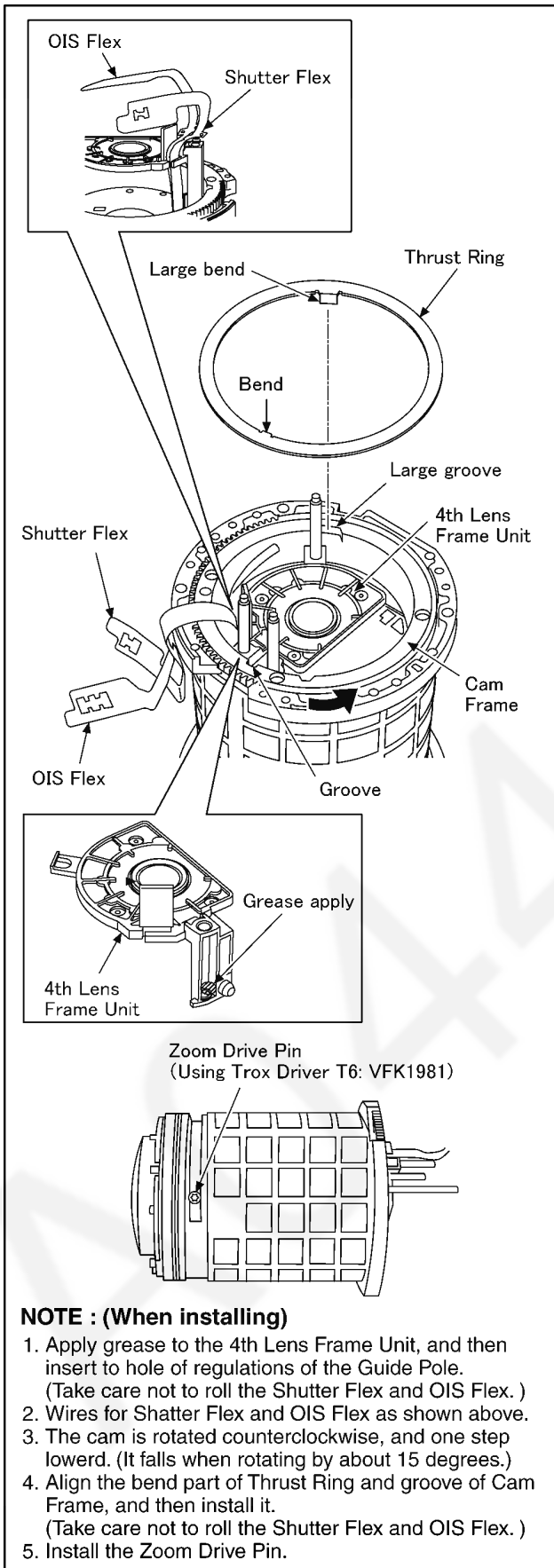

8.5.6. Assembly for the Inside Frame

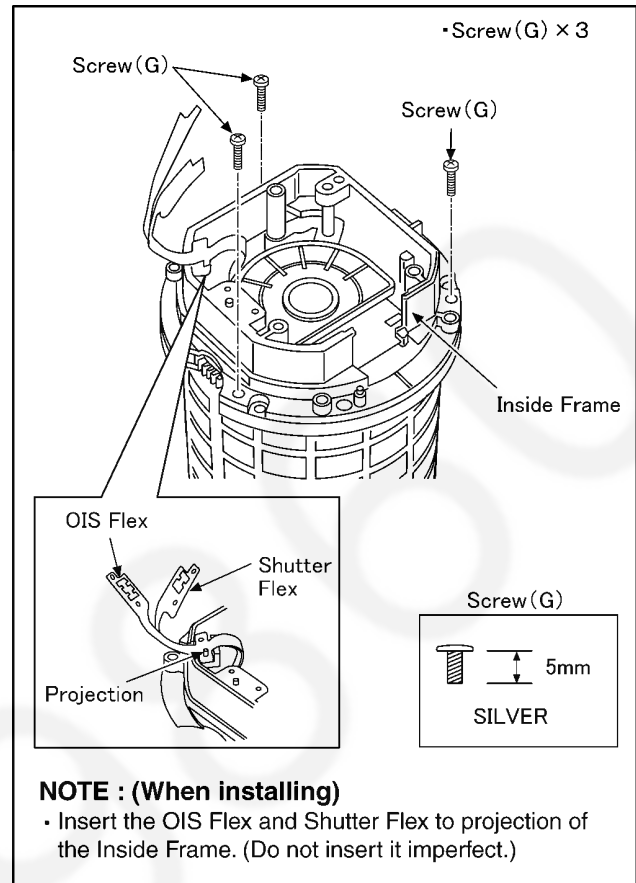

8.5.7. Assembly for the 5th Lens Frame Unit and F Guide Pole L/S

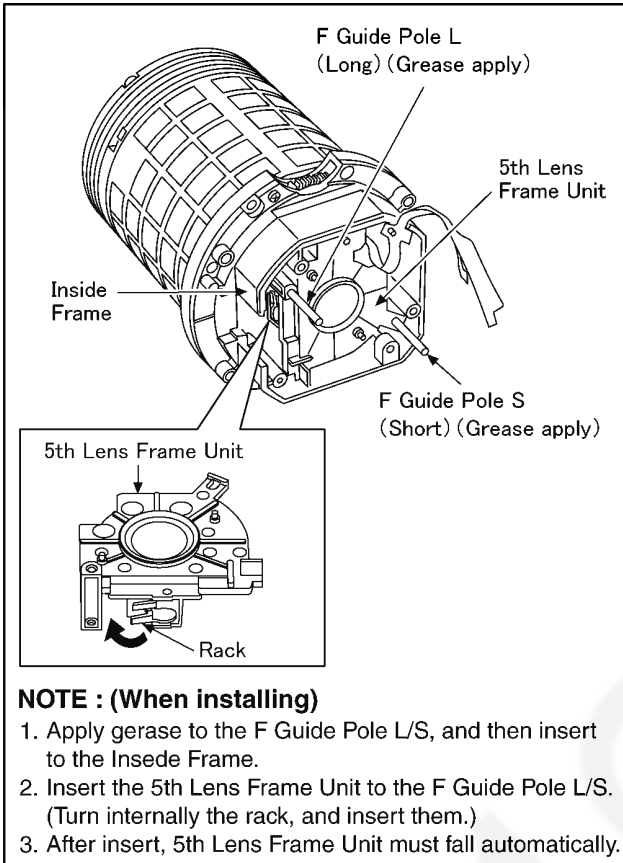

8.5.8. Assembly for the Master Frange

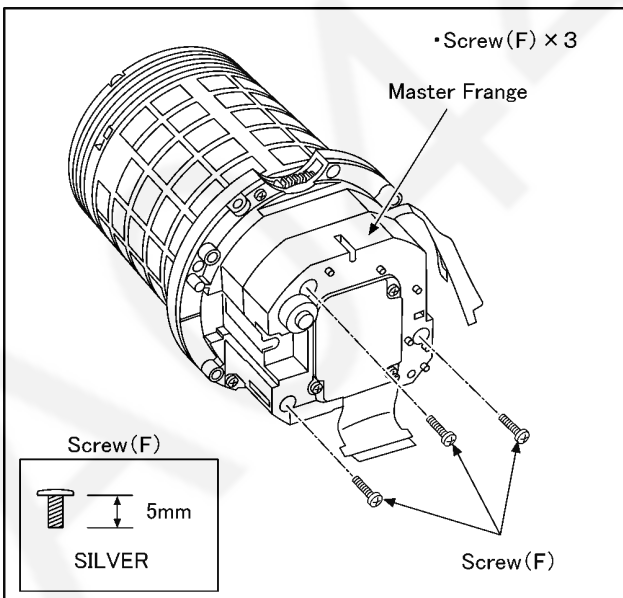

8.5.9. Assembly for the Focus Motor Unit

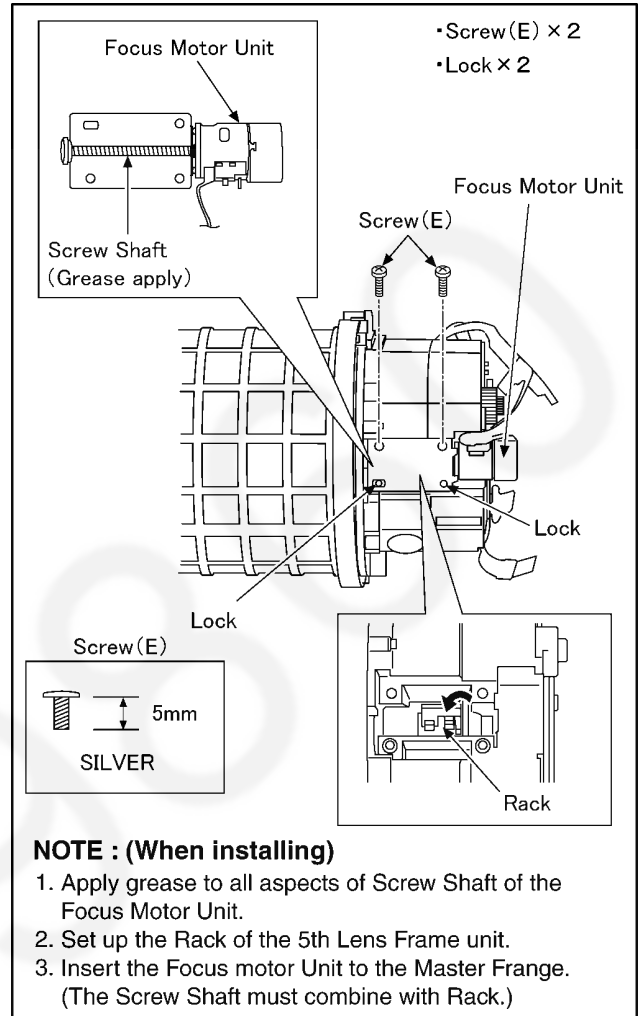

8.5.10. Assembly for the Zoom Encoder Unit

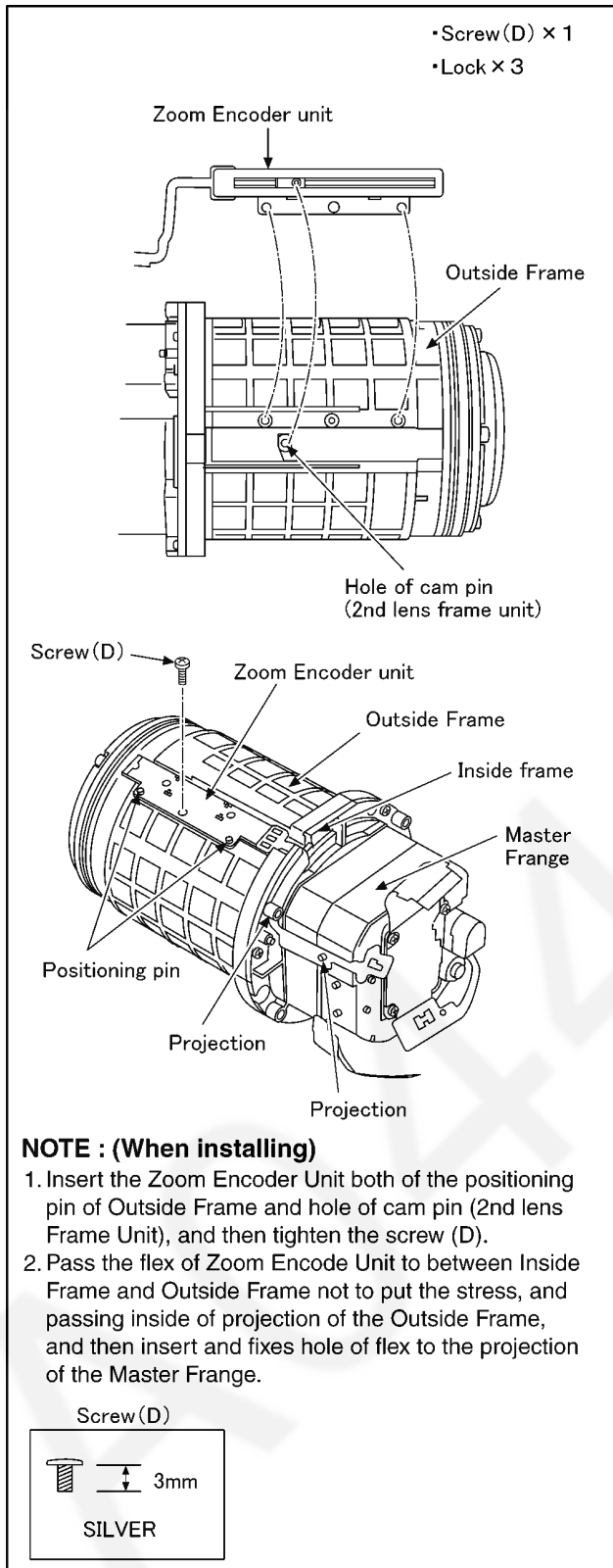

8.5.11. Assembly for the Lens Ring Base and Master Frange Unit

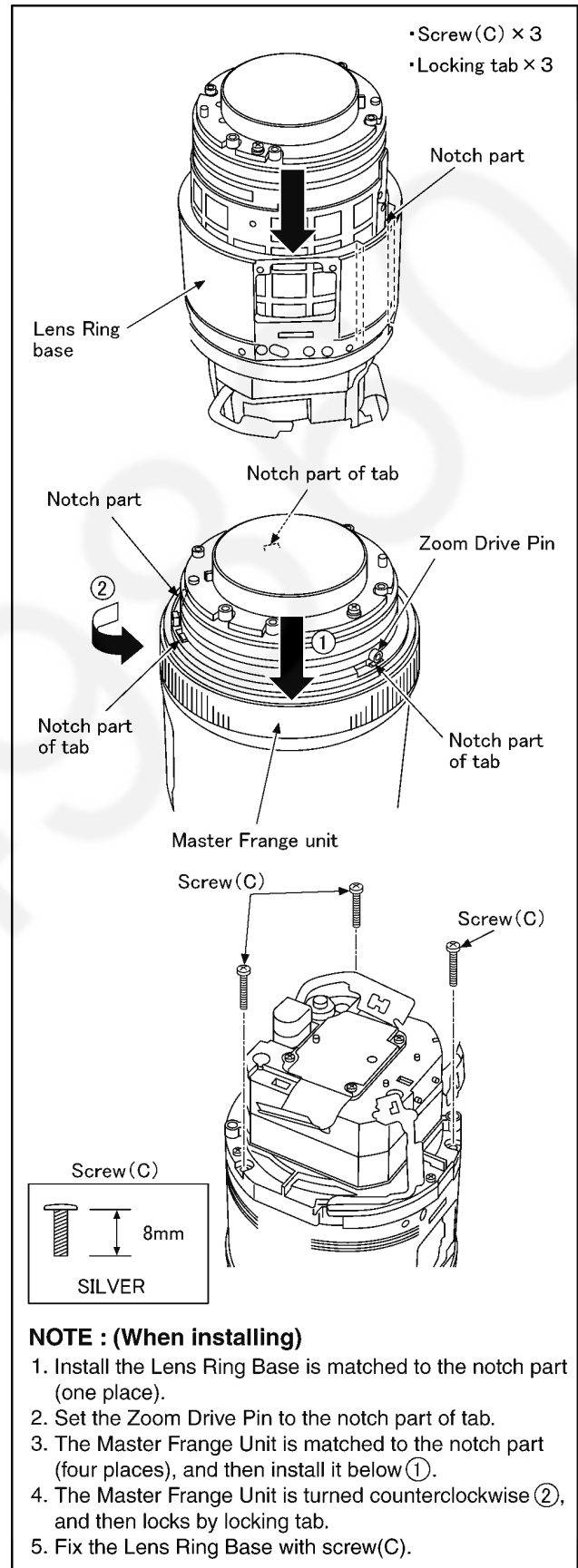

8.5.12. Assembly for the Lens Ring Front and Zoom Ring Unit

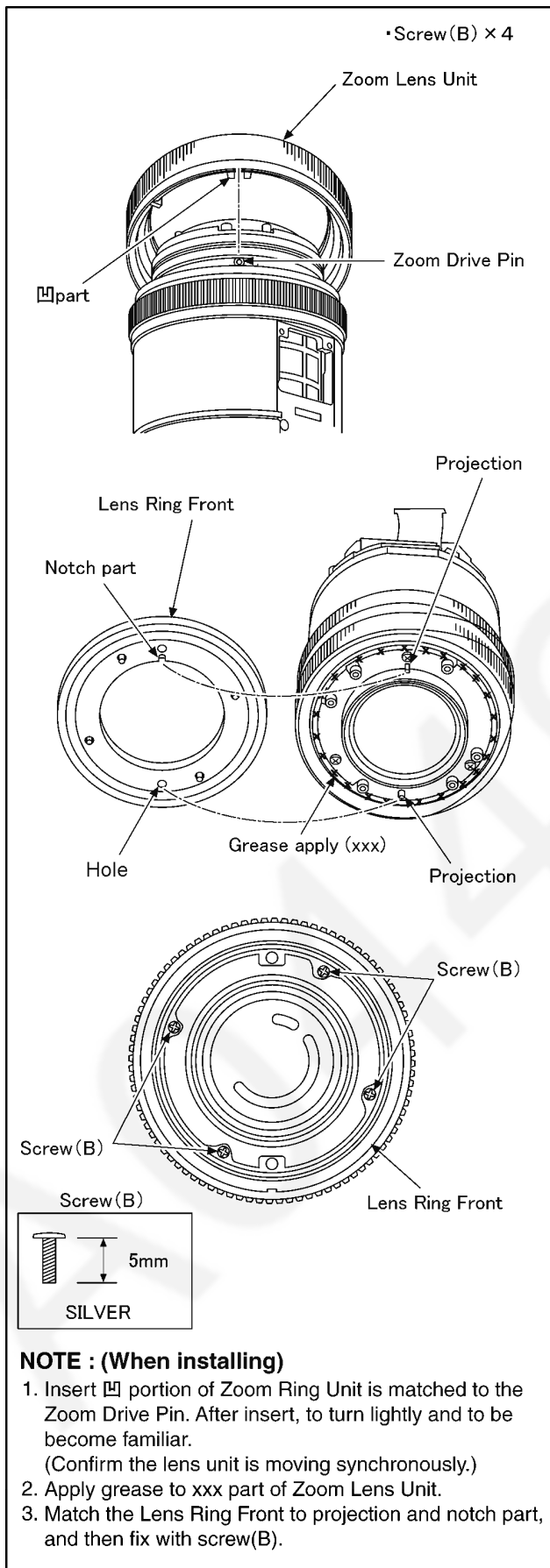

8.5.13. Assembly for the Decoration Ring

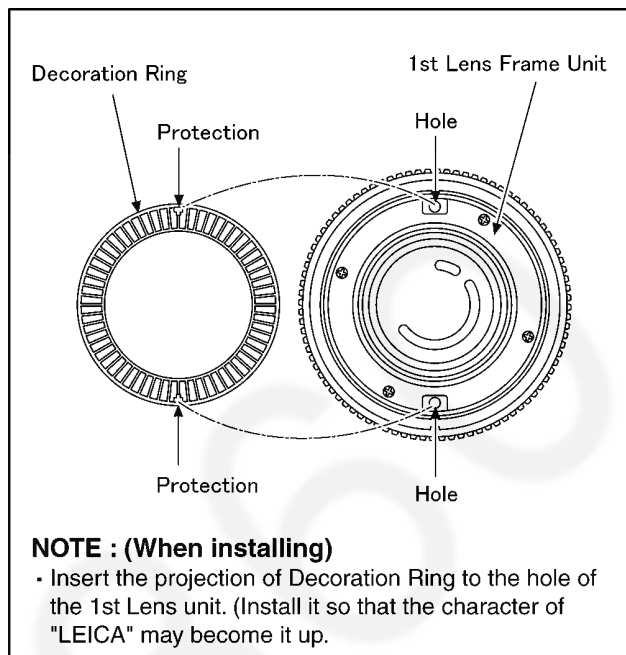

8.5.14. Assembly for the Lens FPC Unit

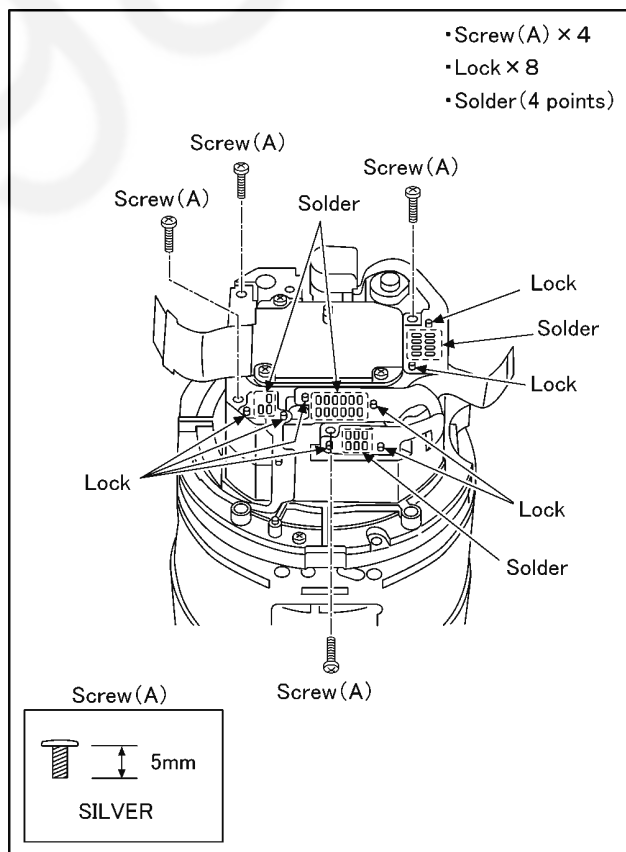

8.6. Removal of the CCD

To prevent the CCD unit from catching the dust and dirt, do not remove the CCD unit except for replacing.

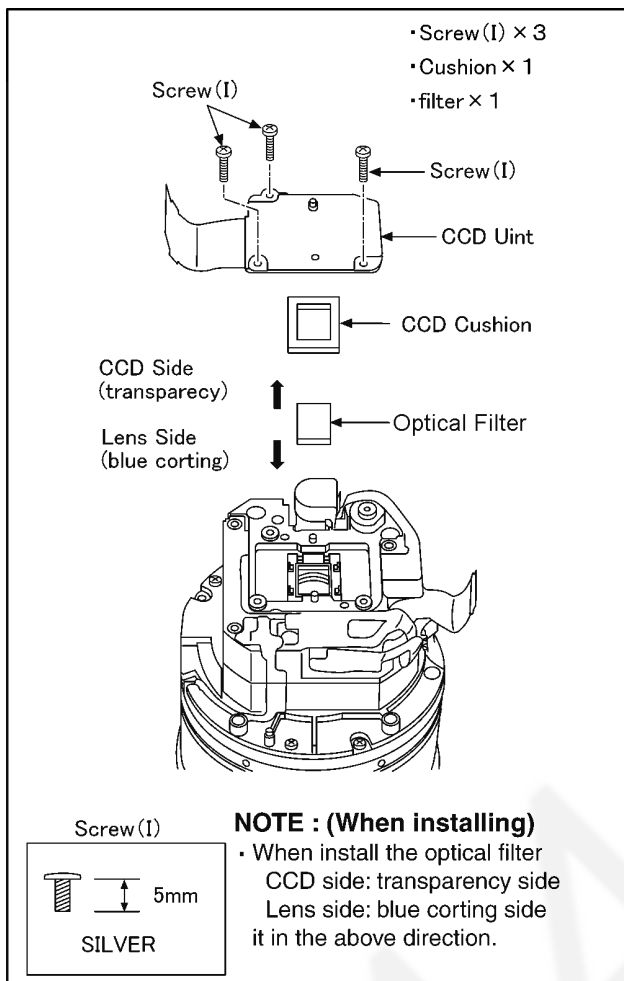

9 Measurements and Adjustments

9.1. Adjustment Procedures

Even if the MAIN PCB is replaced as a unit, it must be achieved the adjustment and factory setting. The adjustment in this unit is separated two types as shown below.

The adjustment instruction is available at "Software download" on the "Support Information from NWBG-PAVC" web-site in "TSN System".

1. **Main unit adjustment:** All adjustments except for LCD and EVF adjustment.

This unit mounts the adjustment software for main unit, it wouldn't need the connection between the PC and this unit with USB cable.

2. **LCD and EVF adjustment:** Adjustment for LCD and EVF.

It need the connection between the PC and this unit with USB cable.

The adjustment instruction is available at "Software download" on the "Support Information from NWBG-PAVC" web-site in "TSN System", together with maintenance software.

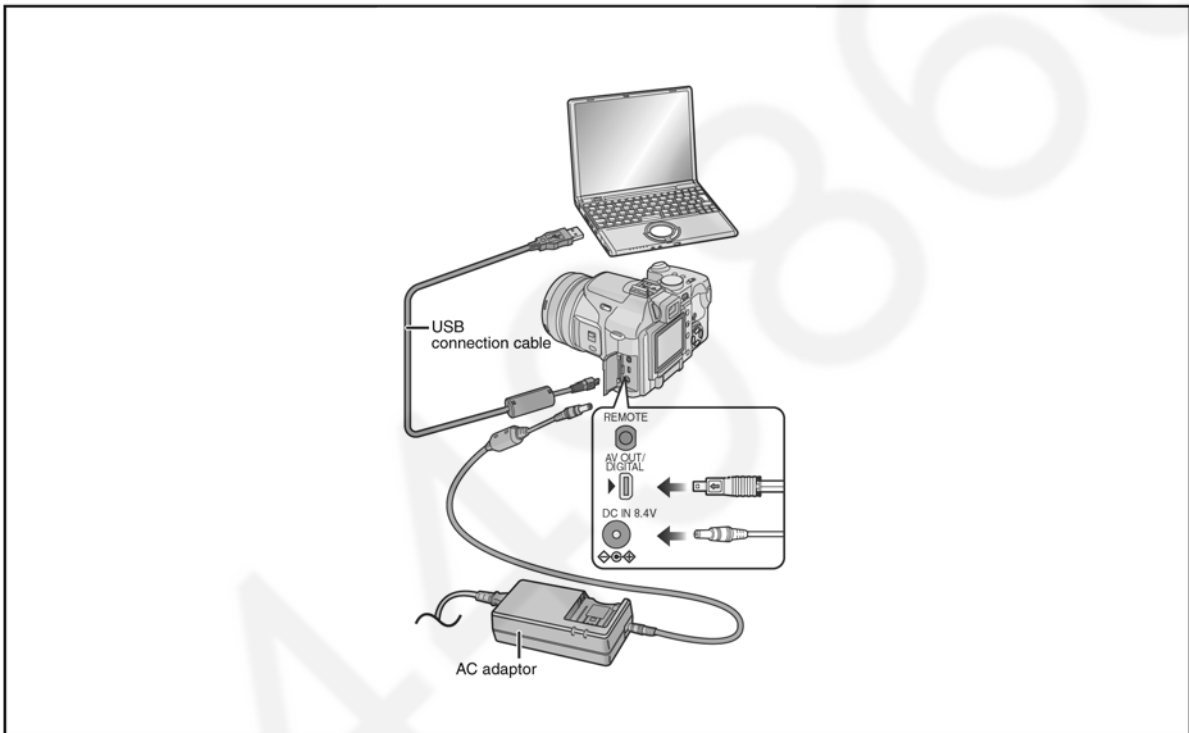

10 Maintenance

10.1. Cleaning Lens, Viewfinder and LCD Panel

Do not touch the surface of lens, Viewfinder and LCD Panel with your hand.

When cleaning the lens, use air-Blower to blow off the dust.

When cleaning the LCD Panel, dampen the lens cleaning paper with lens cleaner, and the gently wipe the their surface.

Note:

A lens cleaning paper and lens cleaner are available at local camera shops and market place.

Service Manual

Diagrams and Replacement Parts List

Digital Camera

DMC-FZ30PP	DMC-FZ30GD
DMC-FZ30PL	DMC-FZ30GK
DMC-FZ30EB	DMC-FZ30GN
DMC-FZ30EG	DMC-FZ30GT
DMC-FZ30EGM	DMC-FZ30SG
DMC-FZ30GC	

Vol. 1

Colour

(S).....Silver Type

(K).....Black Type

S1. ABOUT INDICATION OF THE SCHEMATIC DIAGRAMS

S1.1. IMPORTANT SAFETY NOTICE:

COMPONENTS IDENTIFIED WITH THE MARK \triangle HAVE THE SPECIAL CHARACTERISTICS FOR SAFETY. WHEN REPLACING ANY OF THESE COMPONENTS USE ONLY THE SAME TYPE.

1. Although reference number of the parts is indicated on the P.C.B. drawing and/or schematic diagrams, it is NOT mounted on the P.C.B. when it is displayed with "\$" mark.
2. It is only the "Test Round" and no terminal (Pin) is available on the P.C.B. when the TP (Test Point) indicated as "●" mark.
3. The voltage being indicated on the schematic diagram is measured in "Standard-Playback" mode when there is no specify mode is mentioned.
4. Although the voltage and waveform available on here is measured with standard frame, it may be differ from actual measurement due to modification of circuit and so on.
5. The voltage being indicated here may be include observational-error (deviation) due to internal-resistance and/or reactance of equipment. Therefore, handle the value indicated on here as reference.
6. Use the parts number indicated on the Replacement Parts List .
7. Indication on Schematic diagrams:

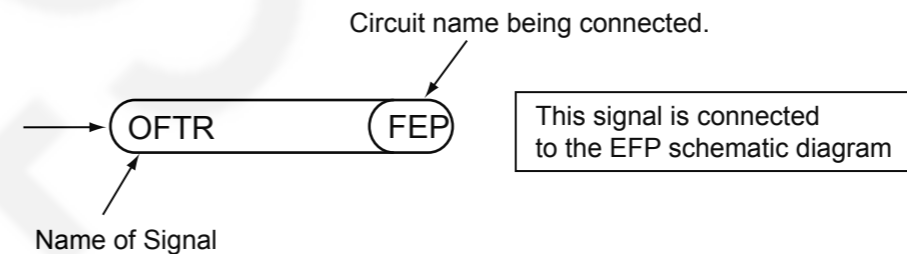
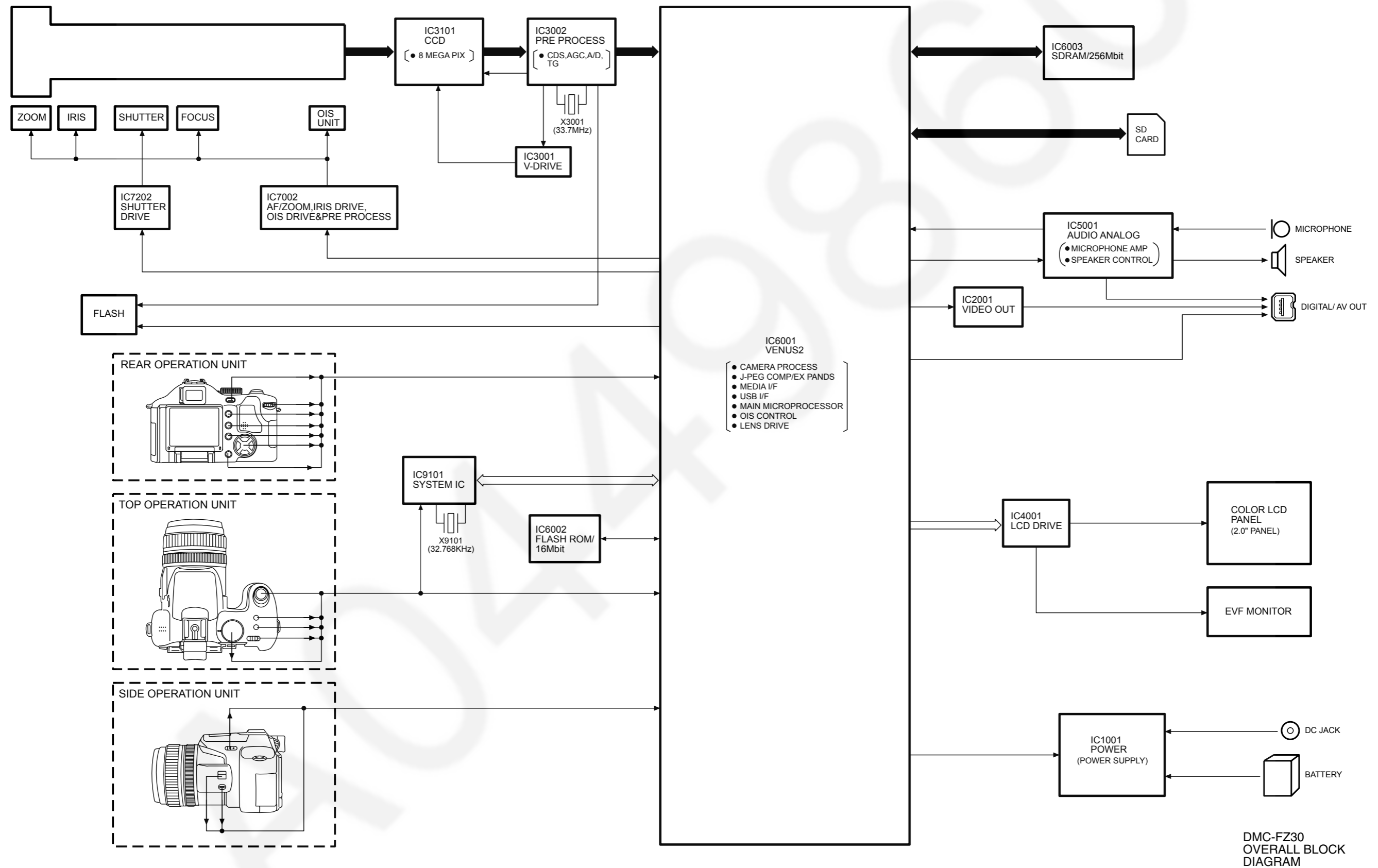

Table of contents

S1. ABOUT INDICATION OF THE SCHEMATIC DIAGRAMS	S-1	S4. PRINT CIRCUIT BOARD	S-13
S1.1. IMPORTANT SAFETY NOTICE:.....	S-1	S4.1. FLASH P.C.B.....	S-13
S2. BLOCK DIAGRAM	S-2	S4.2. LCD IF P.C.B.....	S-14
S2.1. OVERALL BLOCK DIAGRAM.....	S-2	S4.3. AF ASSIST P.C.B.	S-14
S2.2. SYSTEM CONTROL BLOCK DIAGRAM.....	S-3	S4.4. CCD FLEX	S-15
S2.3. VIDEO/AUDIO PROCESS BLOCK DIAGRAM.....	S-4	S4.5. MIC FLEX	S-16
S2.4. SENSOR BLOCK DIAGRAM.....	S-5	S4.6. LENS FLEX.....	S-16
S2.5. LENS DRIVE BLOCK DIAGRAM.....	S-6	S5. REPLACEMENT PARTS LIST	S-17
S2.6. POWER BLOCK DIAGRAM	S-7	S6. EXPLODED VIEWS.....	S-23
S3. SCHEMATIC DIAGRAMS	S-8	S6.1. FRAME & CASING SECTION (1).....	S-23
S3.1. INTERCONNECTION DIAGRAM	S-8	S6.2. FRAME & CASING SECTION (2).....	S-24
S3.2. FLASH SCHEMATIC DIAGRAMS	S-9	S6.3. FRAME & CASING SECTION (3).....	S-25
S3.3. LCD IF FLEX SCHEMATIC DIAGRAMS.....	S-10	S6.4. PACKING PARTS & ACCESSORIES SECTION	S-26
S3.4. AF ASSIST SCHEMATIC DIAGRAMS	S-10		
S3.5. CCD FLEX SCHEMATIC DIAGRAMS	S-11		
S3.6. MIC FLEX SCHEMATIC DIAGRAMS	S-11		
S3.7. LENS FLEX SCHEMATIC DIAGRAMS.....	S-12		

S2. BLOCK DIAGRAM

S2.1. OVERALL BLOCK DIAGRAM



S2.2. SYSTEM CONTROL BLOCK DIAGRAM

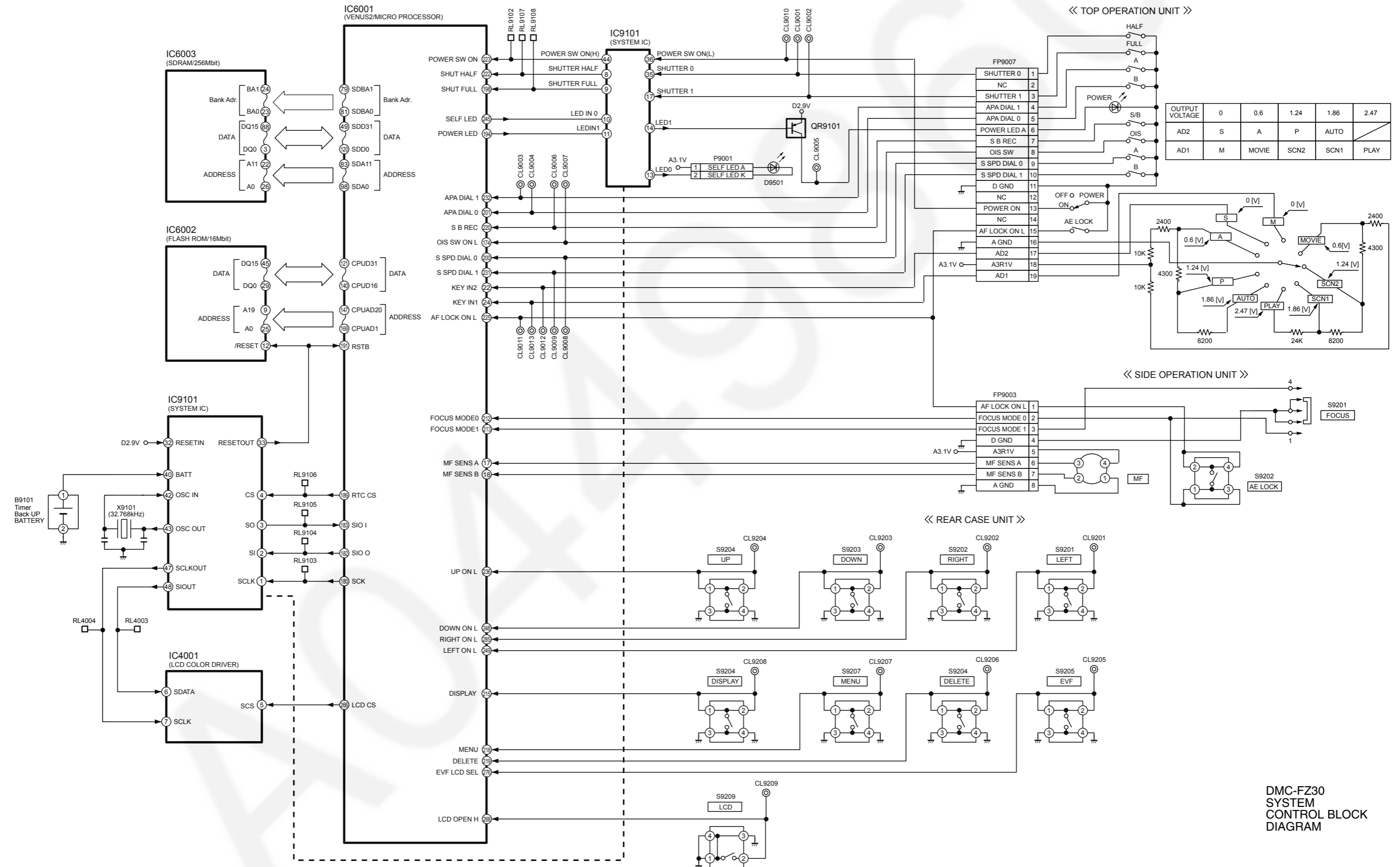

S2.3. VIDEO/AUDIO PROCESS BLOCK DIAGRAM

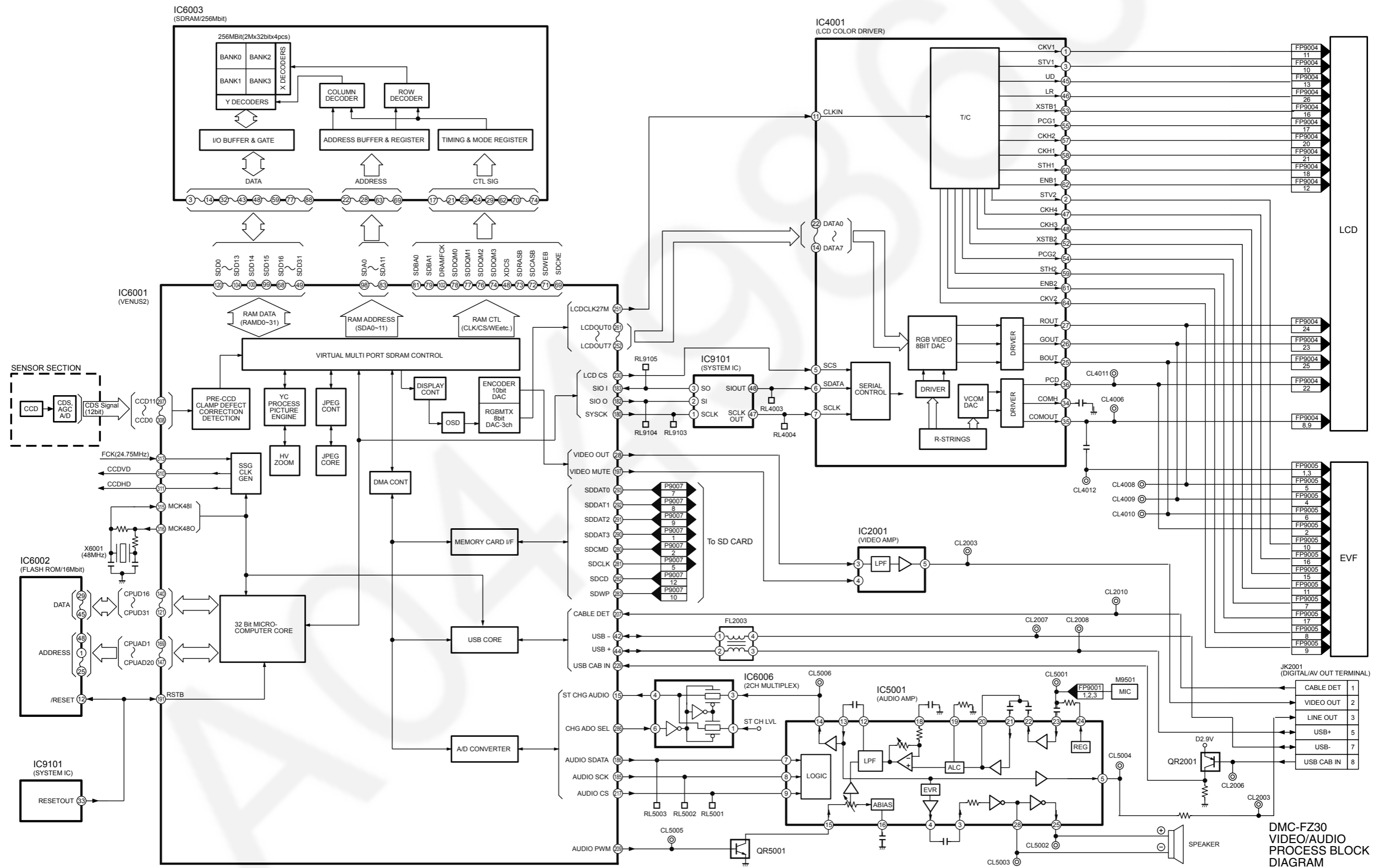

S2.4. SENSOR BLOCK DIAGRAM

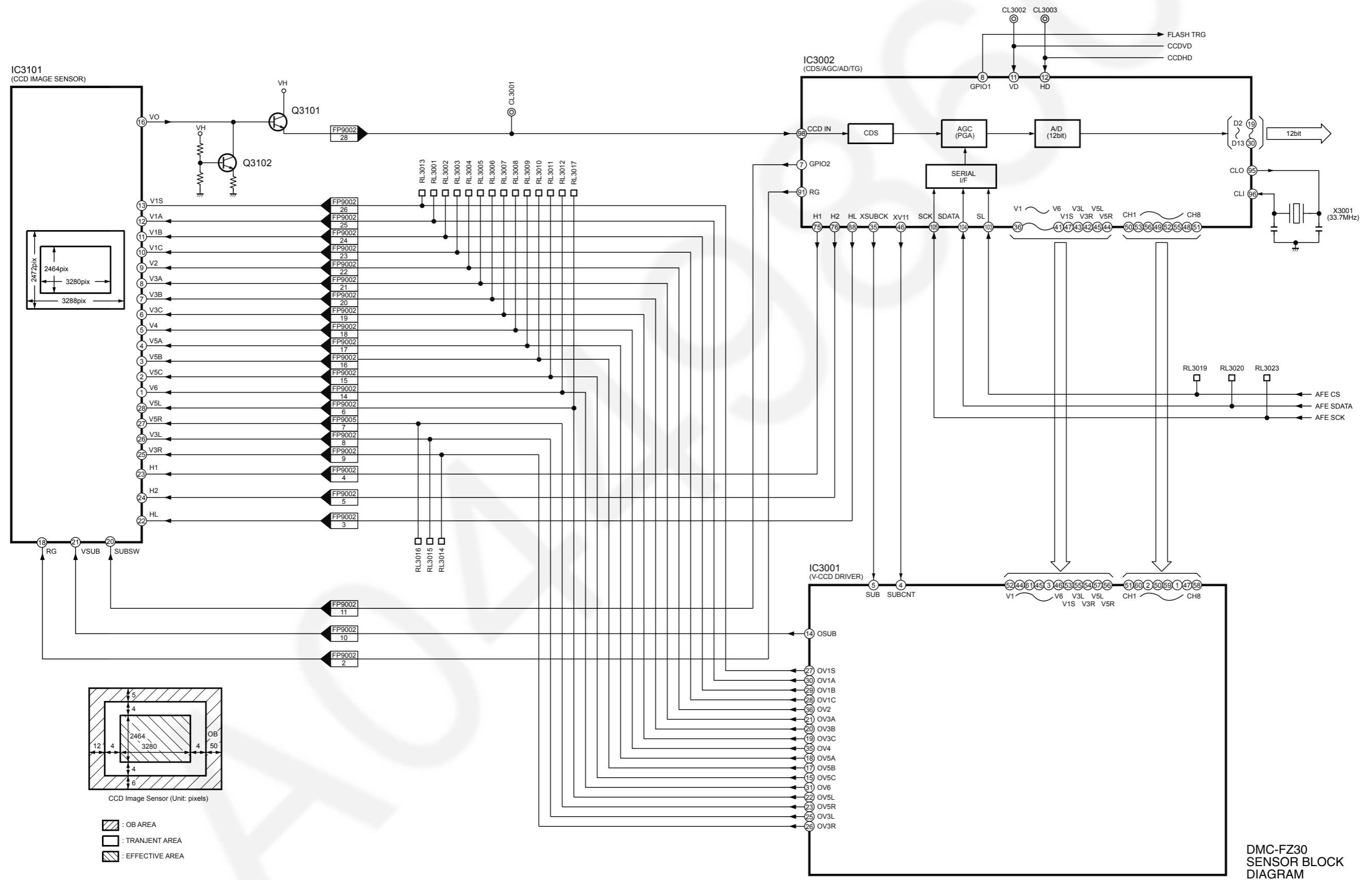

S2.5. LENS DRIVE BLOCK DIAGRAM

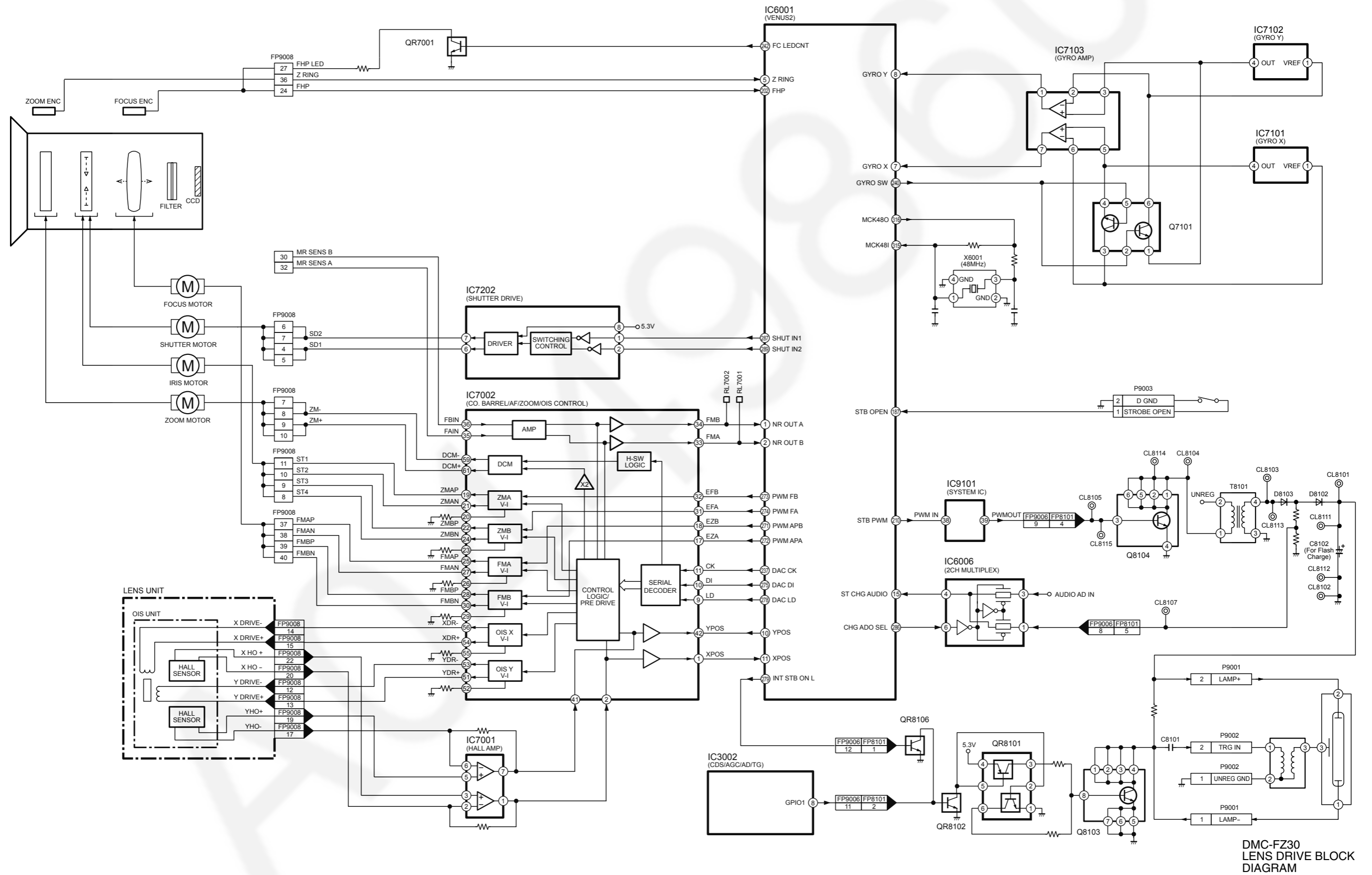

DMC-FZ30
LENS DRIVE BLOCK
DIAGRAM

S2.6. POWER BLOCK DIAGRAM

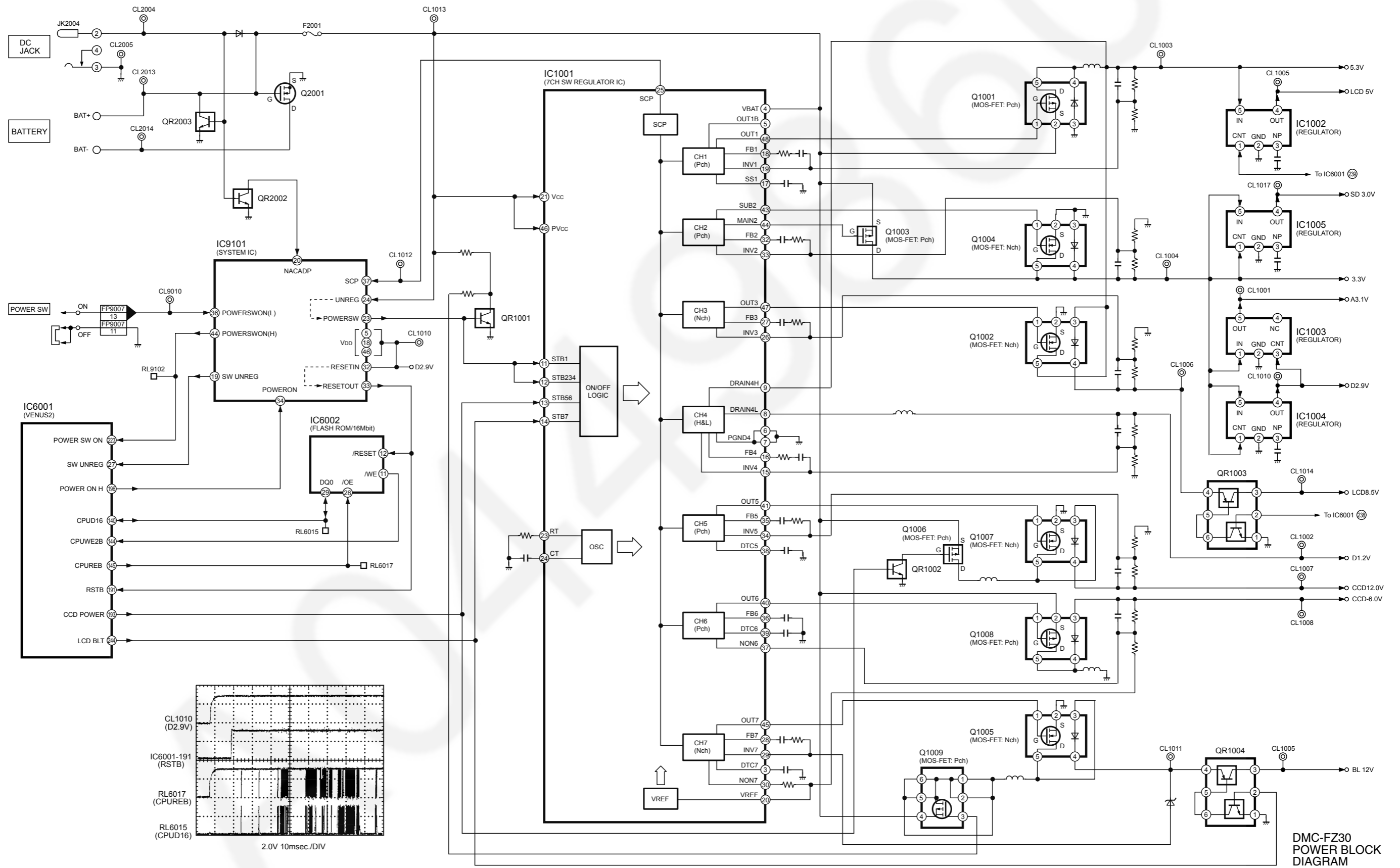

S3. SCHEMATIC DIAGRAMS

S3.1. INTERCONNECTION DIAGRAM

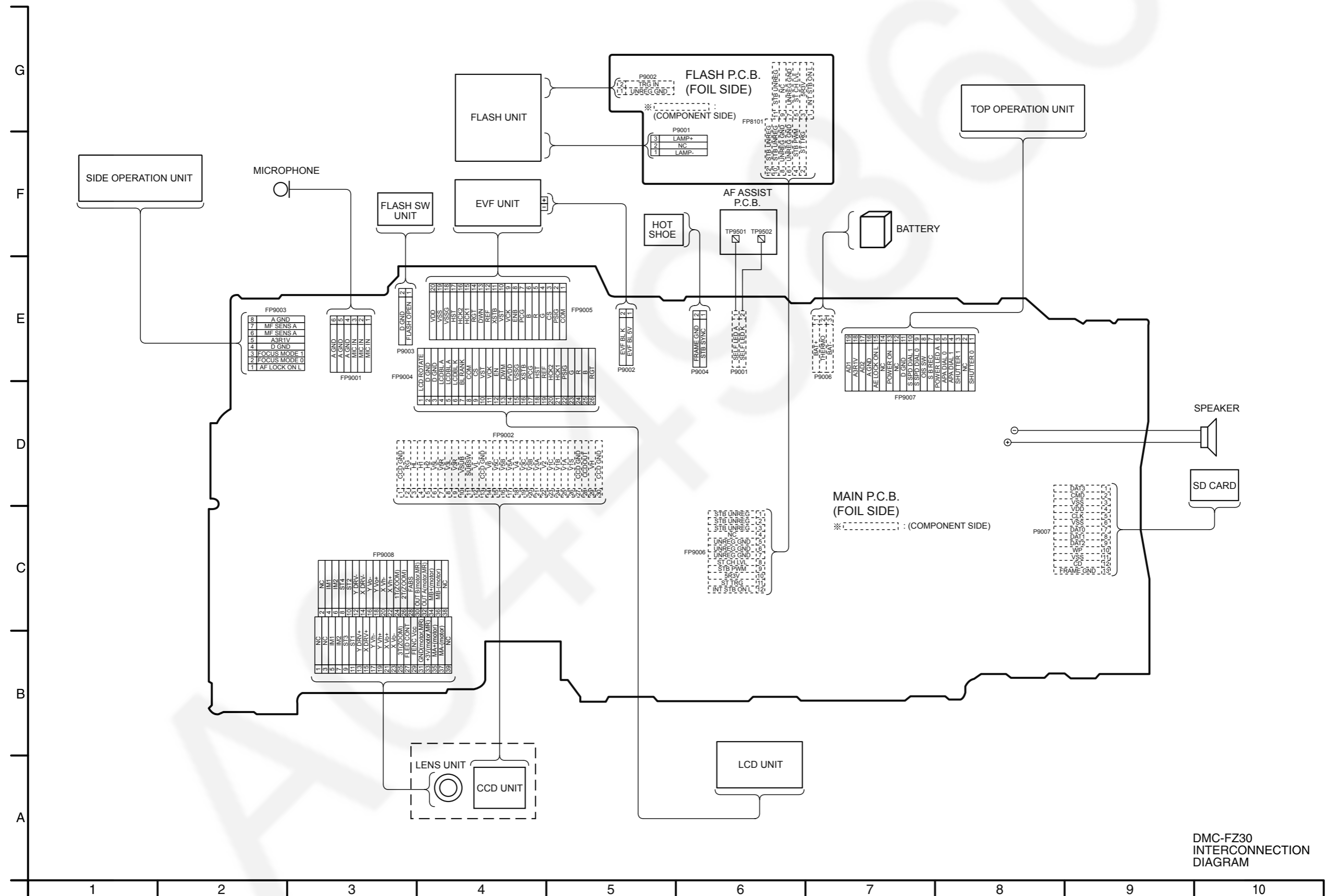

DMC-FZ30 INTERCONNECTION DIAGRAM

S3.2. FLASH SCHEMATIC DIAGRAMS

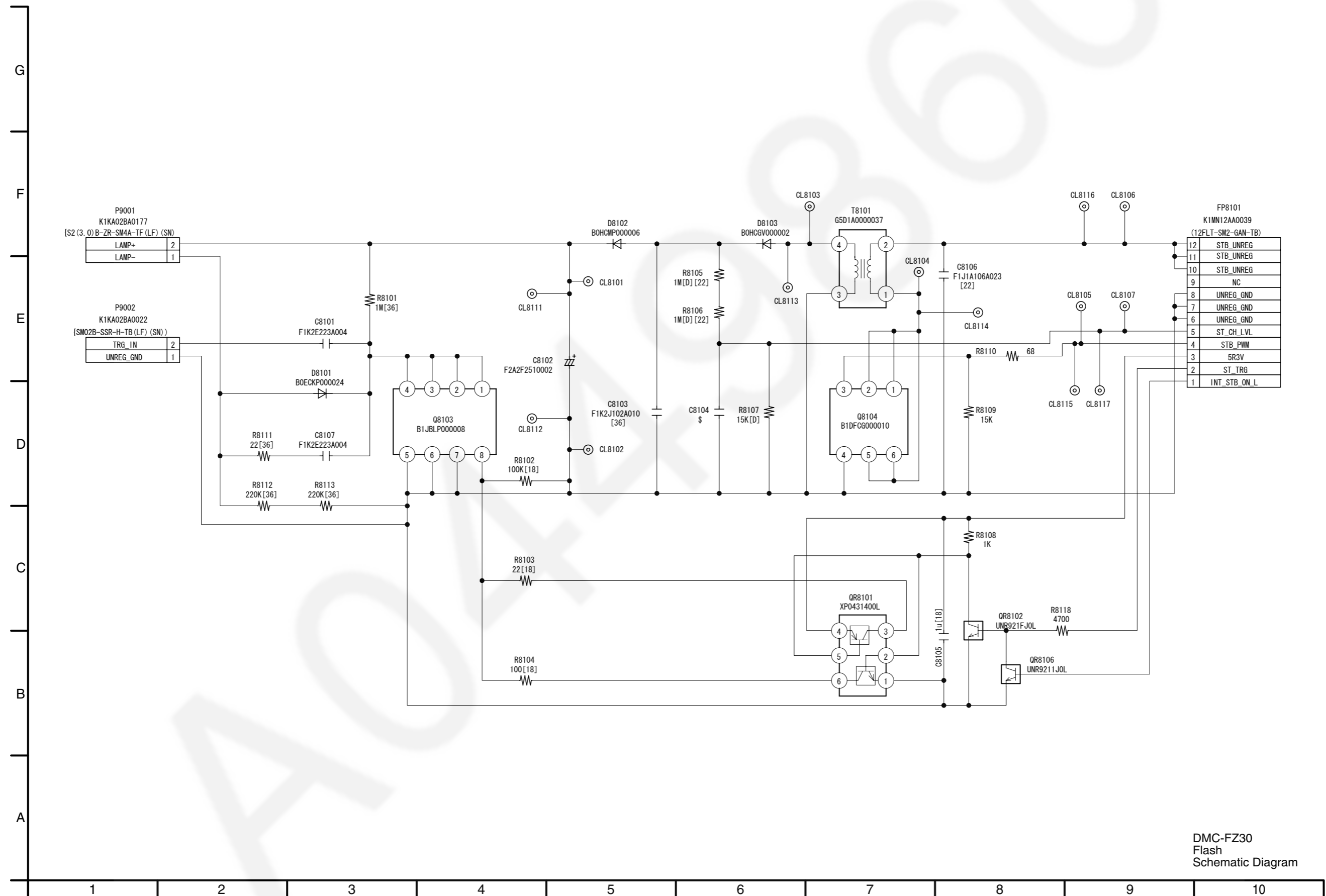

DMC-FZ30
Flash
Schematic Diagram

S3.3. LCD IF FLEX SCHEMATIC DIAGRAMS / S3.4. AF ASSIST SCHEMATIC DIAGRAMS

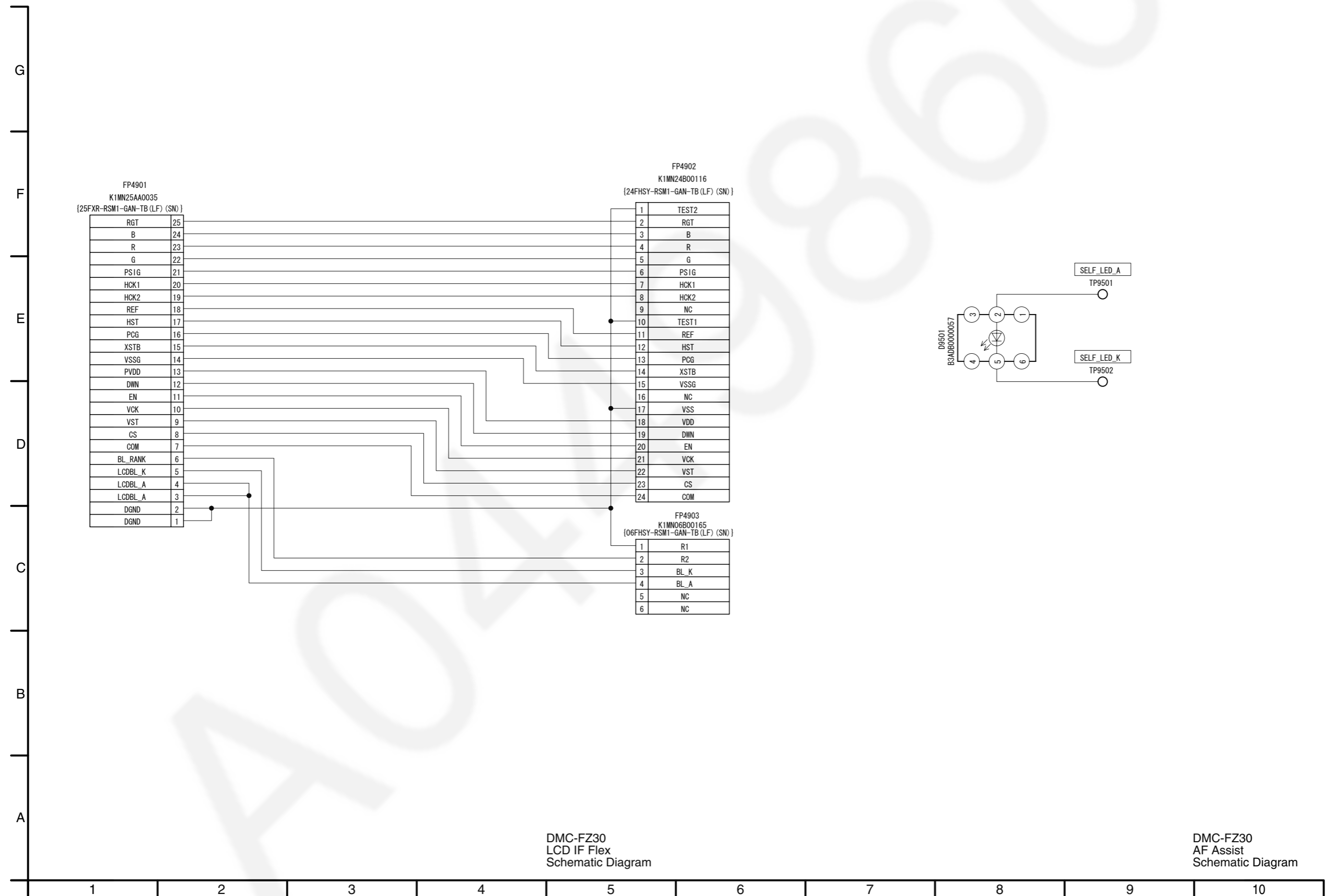

DMC-FZ30
LCD IF Flex
Schematic Diagram

DMC-FZ30
AF Assist
Schematic Diagram

S3.5. CCD FLEX SCHEMATIC DIAGRAMS / S3.6. MIC FLEX SCHEMATIC DIAGRAMS

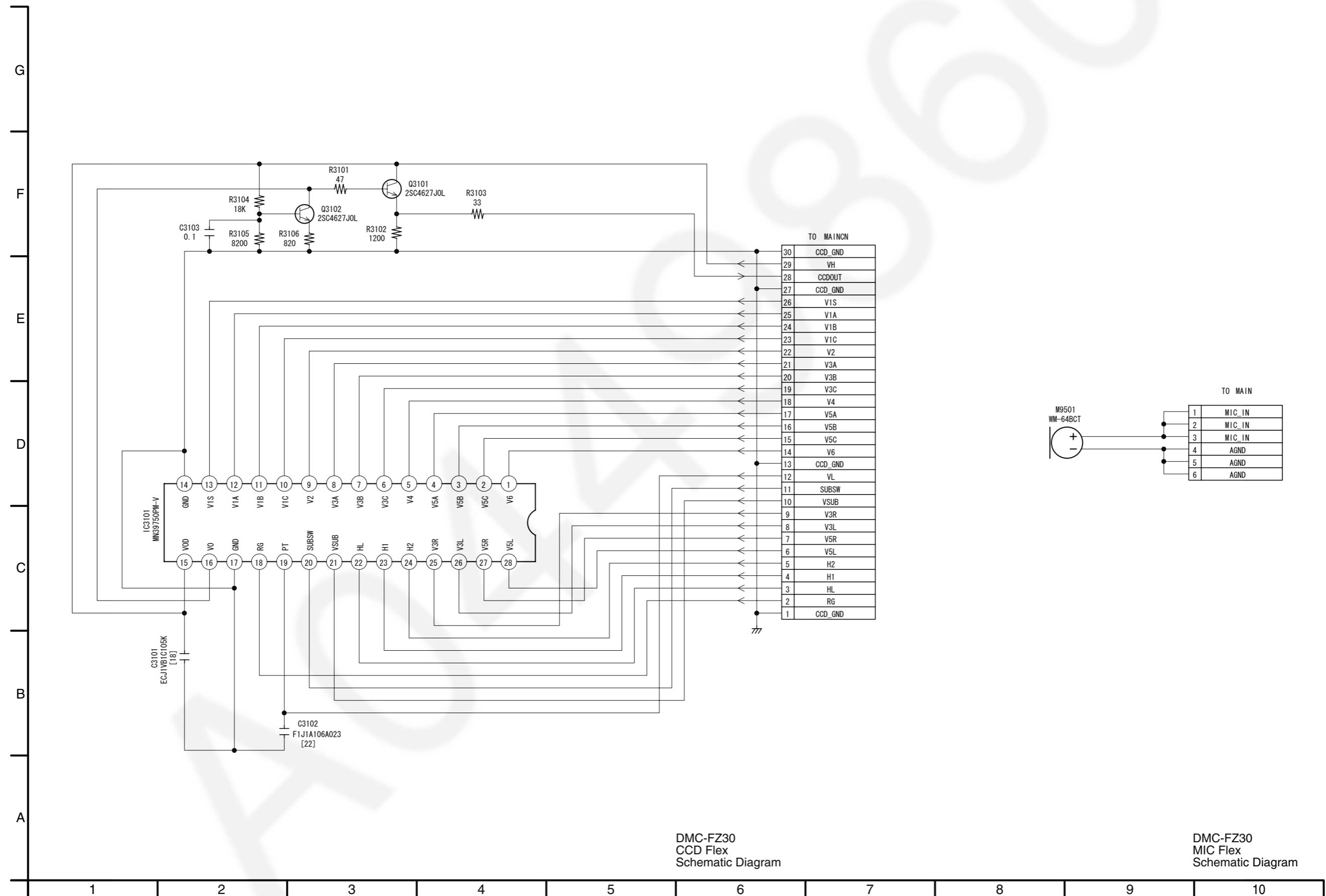

S3.7. LENS FLEX SCHEMATIC DIAGRAMS

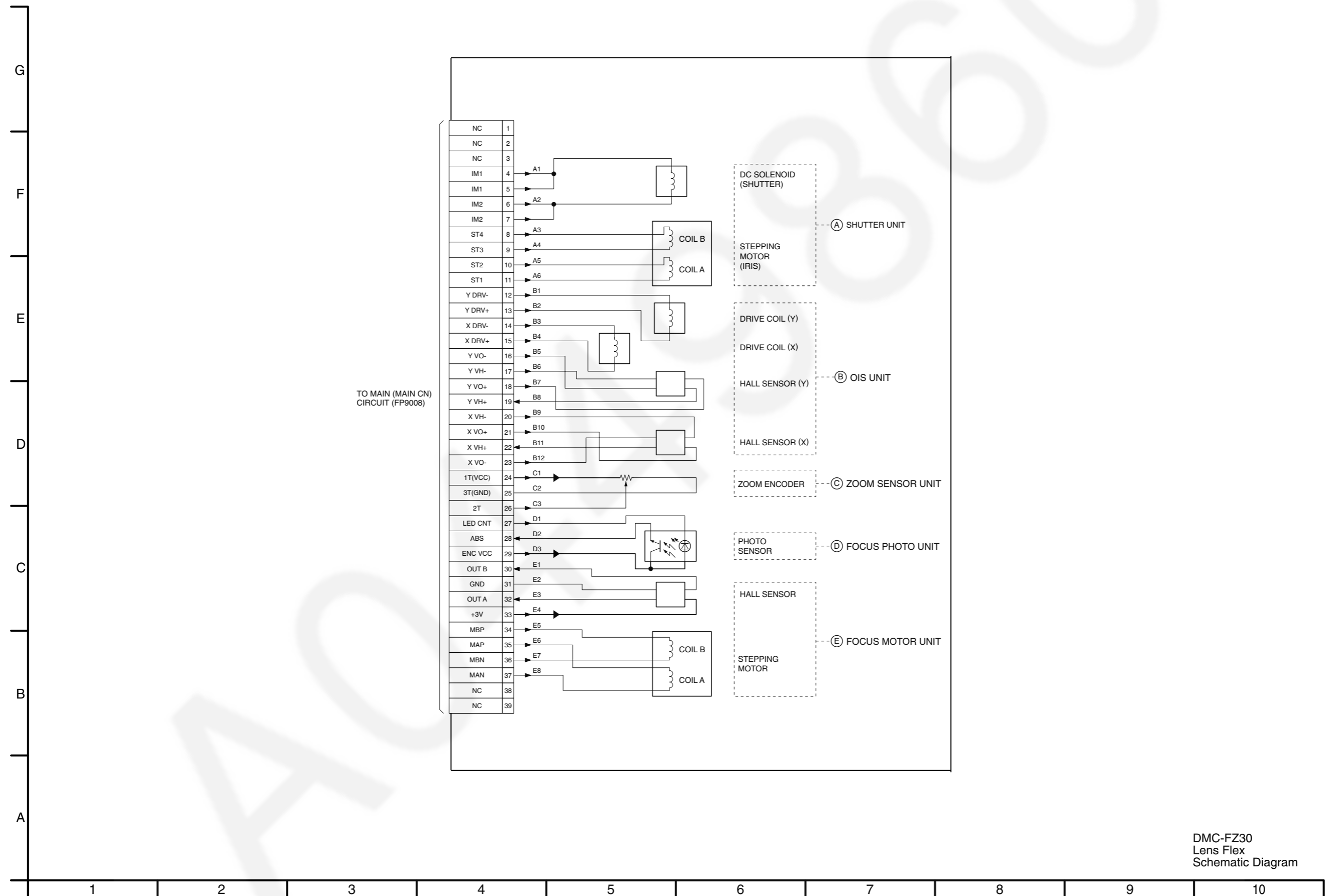

DMC-FZ30
Lens Flex
Schematic Diagram

S4. PRINT CIRCUIT BOARD

S4.1. FLASH P.C.B.

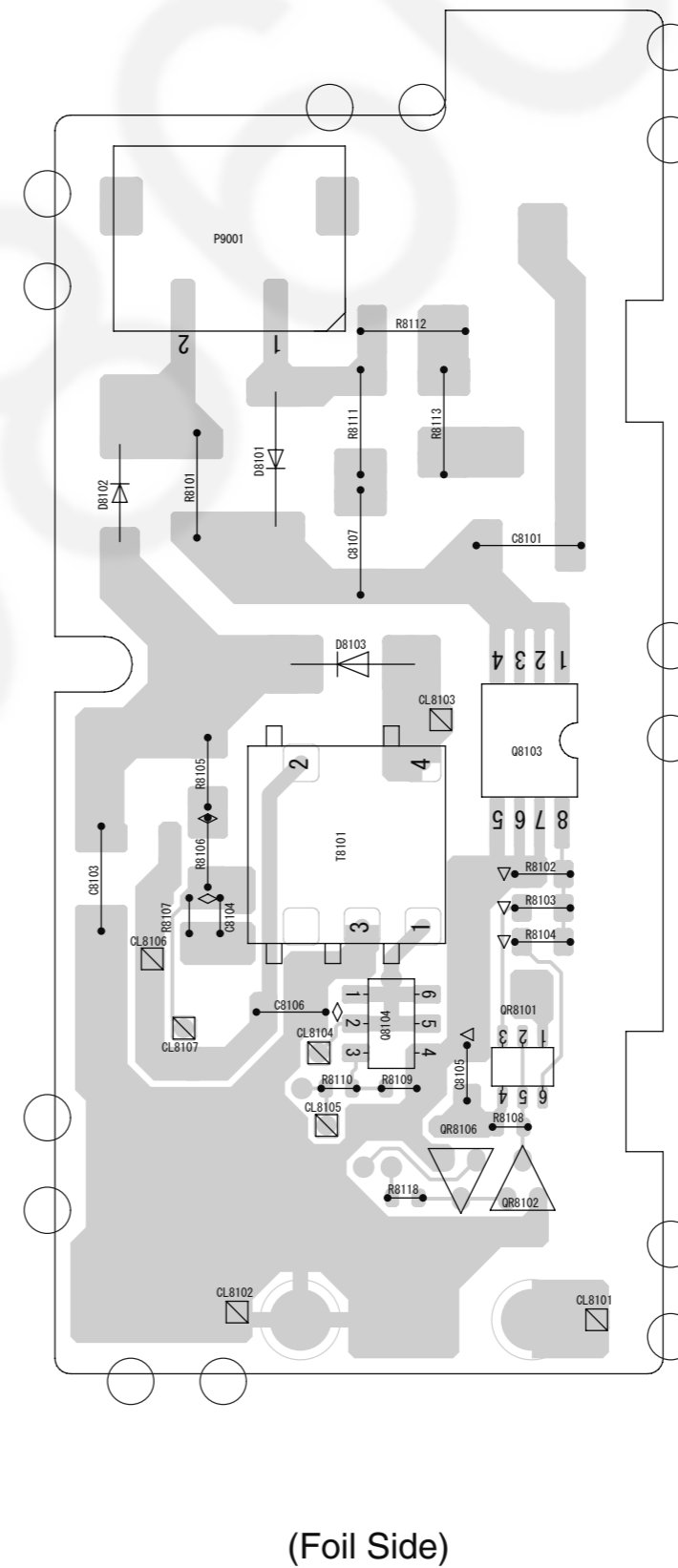
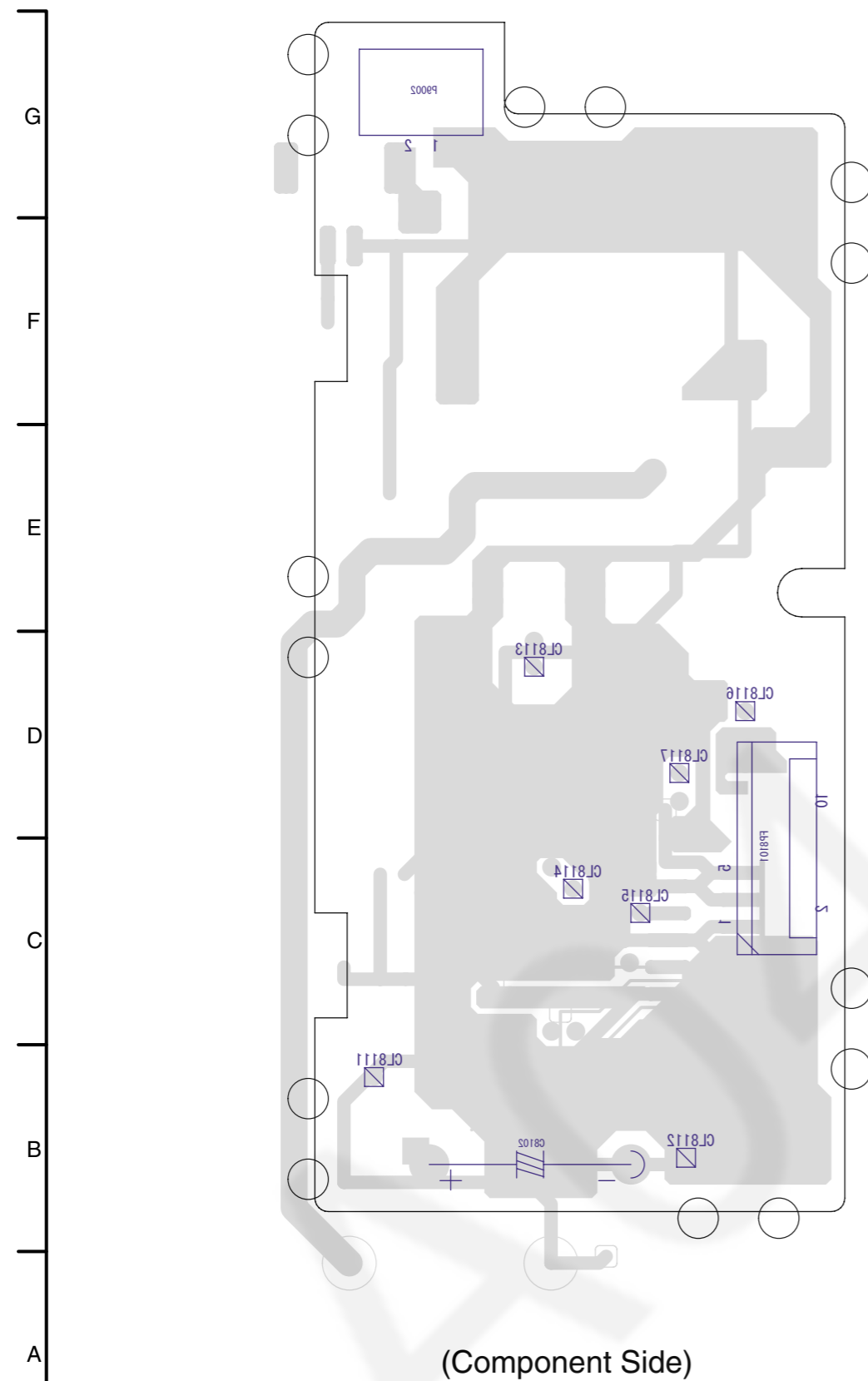

DMC-FZ30
Flash P.C.B.

S4.2. LCD IF P.C.B. / S4.3. AF ASSIST P.C.B.

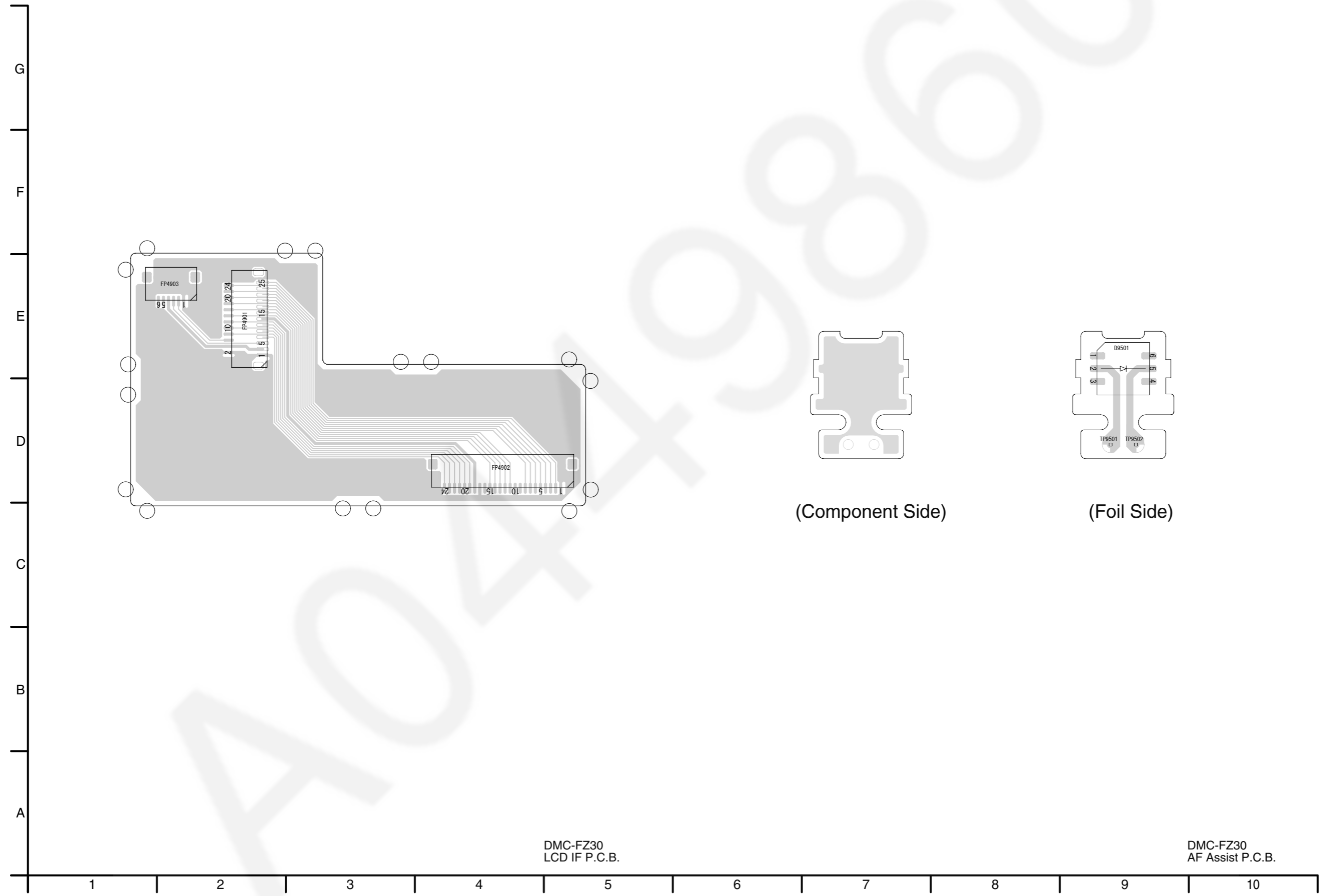

DMC-FZ30
LCD IF P.C.B.

DMC-FZ30
AF Assist P.C.B.

S4.4. CCD FLEX

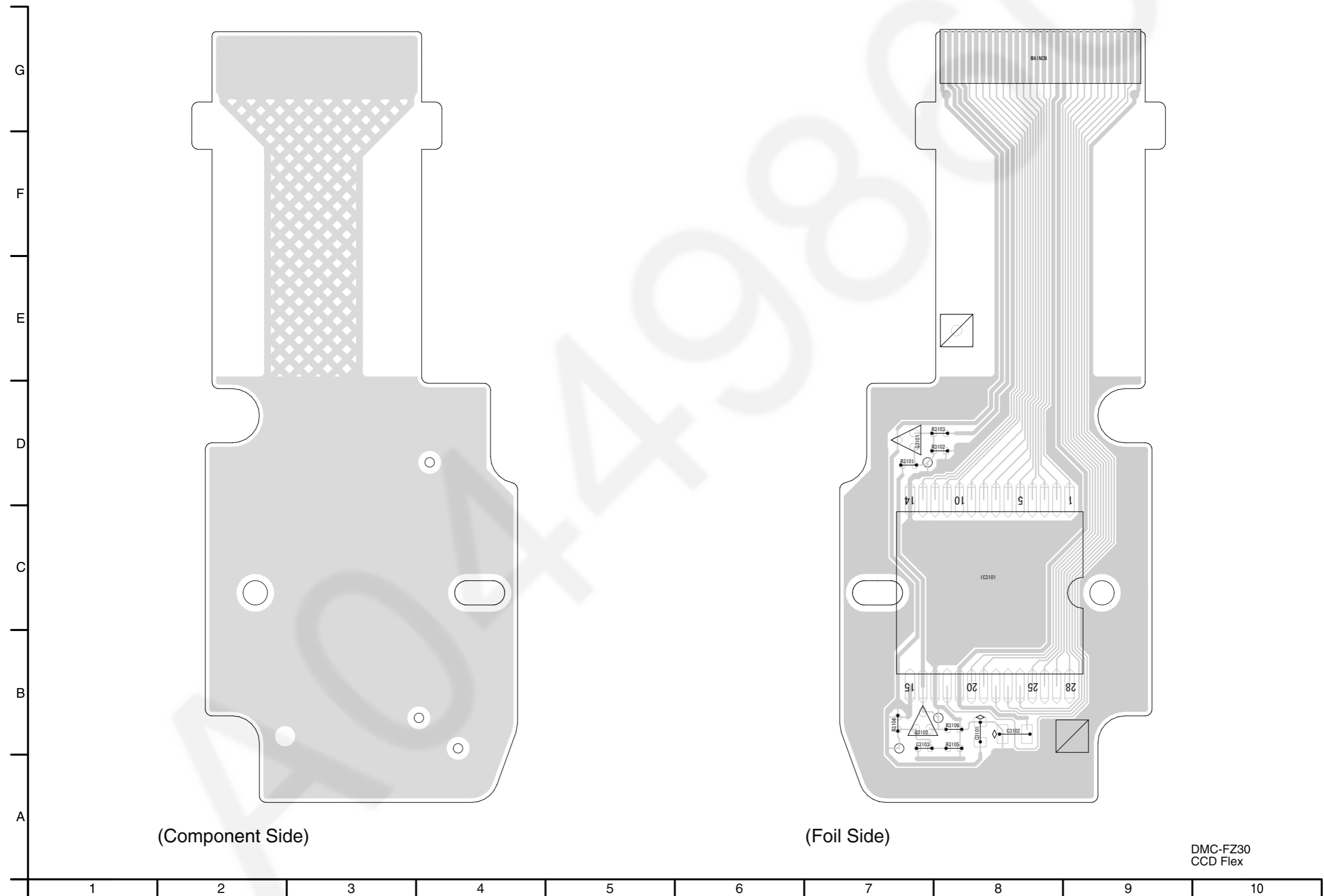

DMC-FZ30
CCD Flex

S4.5. MIC FLEX / S4.6. LENS FLEX

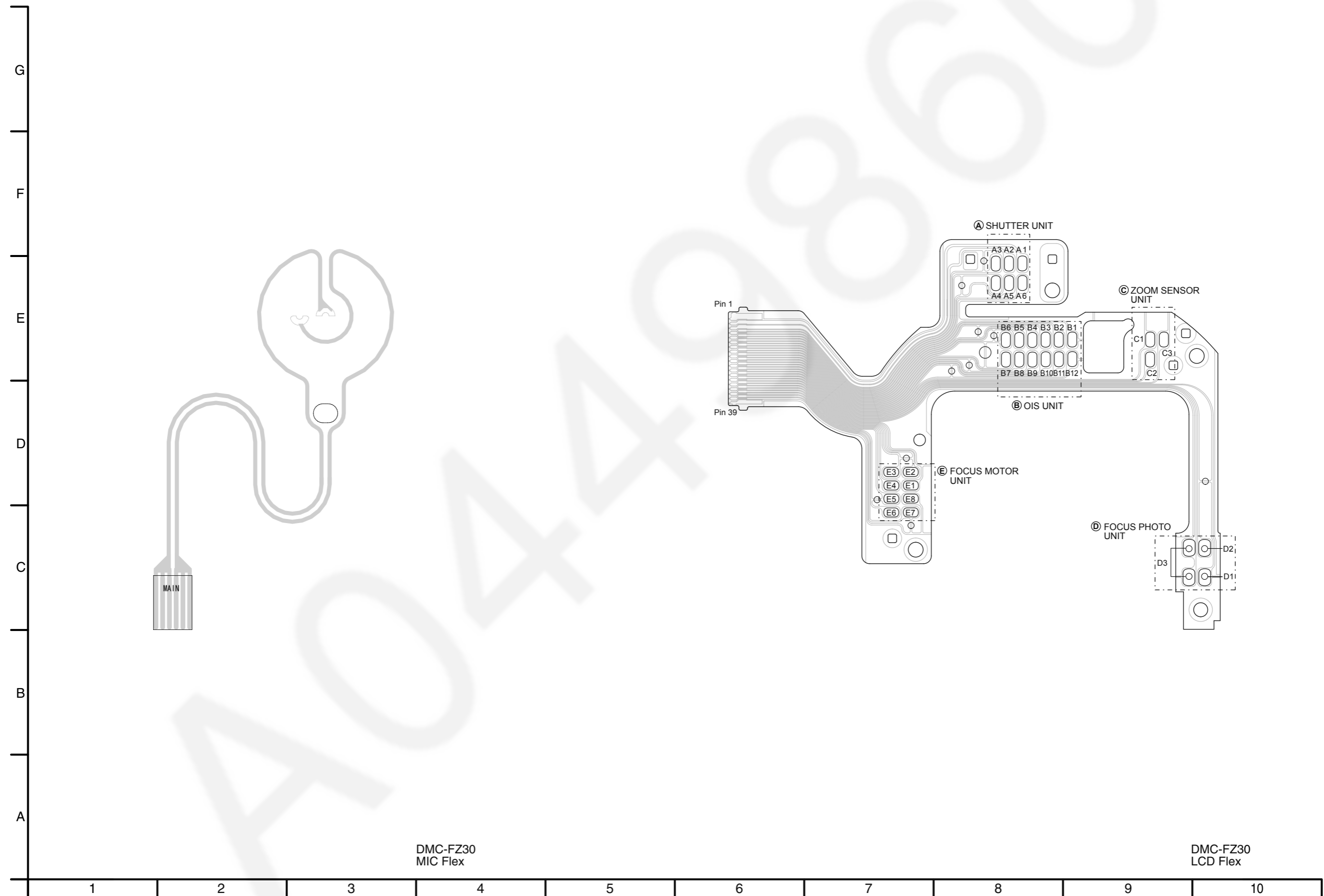

S5. REPLACEMENT PARTS LIST

Note: 1.* Be sure to make your orders of replacement parts according to this list.

2. IMPORTANT SAFETY NOTICE

Components identified with the mark \triangle have the special characteristics for safety. When replacing any of these components, use only the same type.

3. Unless otherwise specified,

All resistors are in OHMS, K=1,000 OHMS. All capacitors are in MICRO-FARADS (uf), P=uuF.

4. The P.C.Board units marked with "■" show below the main assembled parts.

5. The marking (RTL) indicates the retention time is limited for this item. After the discontinuation of this assembly in production, it will no longer be available.

6. Supply of CD-ROM, in accordance with license protection, is allowable as replacement parts only for customers who accidentally damaged or lost their own.

E.S.D. standards for Electrostatically Sensitive Devices, refer to "PREVENTION OF ELECTROSTATIC DISCHARGE (ESD) TO ELECTROSTATICALLY SENSITIVE (ES) DEVICES" section.

Definition of Parts supplier:

1. Parts marked with [MBI] in the remarks column are supplied from "Matsushita Battery Industrial co., Ltd.".
2. Parts marked with [PAVC-CSG] in the remarks column are supplied from PAVC COMPANY CS Group (PAVC-CSG). Others are supplied from MKE SAIJYO (MKE).

DMC-FZ30PP/PL/EB/EG/EGM/GC/GD/GK/GN/GT/SG

Ref.No.	Part No.	Part Name & Description	Pcs	Remarks
		----- P.C.B. LIST -----		
	VEP56025A	MAIN C.B.A.	1	E.S.D. [RTL]
	VEP58014A	FLASH C.B.A.	1	(RTL)
	VEP54003A	LCD IF C.B.A.	1	(RTL)
	VEP59016A	AF ASSIST C.B.A.	1	(RTL)
	VEK0J07	CCD C.B.A.	1	[PAVC-CSG]
		--- ELEC. COMPONENTS ---		
	VEP58014A	FLASH C.B.A.		(RTL)
C8101	F1K2E223A004	C.CAPACITOR CH 250V0.022U	1	
C8102	F2A2F2510002	E.CAPACITOR 315V 250UF	1	
C8103	F1K2J102A010	C.CAPACITOR CH 630V 1000P	1	
C8105	ECJ1VB0J105K	C.CAPACITOR CH 6.3V 1UF	1	
C8106	F1J1A106A023	C.CAPACITOR CH 10V 10UF	1	
C8107	F1K2E223A004	C.CAPACITOR CH 250V0.022U	1	
D8101	B0ECKP000024	DIODE	1	
D8102	B0HCMPO00006	DIODE	1	
D8103	B0HCGV000002	DIODE	1	
FP8101	K1MN12AA0039	CONNECTOR 12P	1	
P9001	K1KA02BA0177	CONNECTOR 2P	1	
P9002	K1KA02BA0022	CONNECTOR 2P	1	
Q8103	B1JBLP000008	TRANSISTOR NPN	1	
Q8104	B1DFCG000010	TRANSISTOR FET	1	
QR8101	XP0431400L	T. COMPLEX COMPONENT	1	
QR8102	UNR921FJ08	TRANSISTOR RESISTOR NPN	1	UNR921FJOL
QR8106	UNR9211J08	TRANSISTOR RESISTOR NPN	1	UNR9211JOL
R8101	ERJ8GEYJ105V	M.RESISTOR CH 1/8W 1M	1	
R8102	ERJ3GEYJ104V	M.RESISTOR CH 1/16W 100K	1	
R8103	ERJ3GEYJ220V	M.RESISTOR CH 1/16W 22	1	
R8104	ERJ3GEYJ101V	M.RESISTOR CH 1/16W 100	1	
R8105	ERJ6RED105V	M.RESISTOR CH 1/10W 1M	1	
R8106	ERJ6RED105V	M.RESISTOR CH 1/10W 1M	1	
R8107	ERJ2RHD153X	M.RESISTOR CH 1/16W 15K	1	
R8108	ERJ2GEJ102X	M.RESISTOR CH 1/16W 1K	1	
R8109	ERJ2GEJ153X	M.RESISTOR CH 1/16W 15K	1	
R8110	ERJ2GEJ680X	M.RESISTOR CH 1/16W 68	1	
R8111	ERJ8GEYJ220V	M.RESISTOR CH 1/8W 22	1	
R8112	ERJ8GEYJ224V	M.RESISTOR CH 1/8W 220K	1	
R8113	ERJ8GEYJ224V	M.RESISTOR CH 1/8W 220K	1	
R8118	ERJ2GEJ472X	M.RESISTOR CH 1/16W 4.7K	1	
T8101	G5D1A0000037	TRANSFORMER	1	
	VEP54003A	LCD IF C.B.A.		(RTL)
FP4901	K1MN25AA0035	CONNECTOR 25P	1	
FP4902	K1MN24B00116	CONNECTOR 24P	1	
FP4903	K1MNO6B00165	CONNECTOR 6P	1	

Ref.No.	Part No.	Part Name & Description	Pcs	Remarks
	VEP59016A	AF ASSIST C.B.A.		(RTL)
D9501	B3ADB0000057	LIGHT EMITTING DIODE	1	
		MISCELLANEOUS		
	VEE1B83	CONNECTOR	1	
	VEK0J07	CCD C.B.A.		[PAVC-CSG]
C3101	ECJ1VB1C105K	C.CAPACITOR CH 16V 1UF	1	[PAVC-CSG]
C3102	F1J1A106A023	C.CAPACITOR CH 10V 10UF	1	[PAVC-CSG]
C3103	ECJ0EB1A104K	C.CAPACITOR CH 10V 0.1UF	1	[PAVC-CSG]
Q3101	2SC4627JCL	TRANSISTOR NPN	1	[PAVC-CSG]
Q3102	2SC4627JCL	TRANSISTOR NPN	1	[PAVC-CSG]
R3101	ERJ2GEJ470	M.RESISTOR CH 1/16W 47	1	[PAVC-CSG]
R3102	ERJ2GEJ122	M.RESISTOR CH 1/16W 1.2K	1	[PAVC-CSG]
R3103	ERJ2RJD330	M.RESISTOR CH 1/16W 33	1	[PAVC-CSG]
R3104	ERJ2GEJ183	M.RESISTOR CH 1/16W 18K	1	[PAVC-CSG]
R3105	ERJ2GEJ822	M.RESISTOR CH 1/16W 8.2K	1	[PAVC-CSG]
R3106	ERJ2GEJ821	M.RESISTOR CH 1/16W 820	1	[PAVC-CSG]

DMC-FZ30PP/PL/EB/EG/EGM/GC/GD/GK/GN/GT/SG
M1

Ref.No.	Part No.	Part Name & Description	Pcs	Remarks	Ref.No.	Part No.	Part Name & Description	Pcs	Remarks
1	VYK1S97	FRONT CASE UNIT	1	BLACK	B27	VHD1684	SCREW	1	BLACK
1	VYK1S98	FRONT CASE UNIT	1	SILVER	B27	VHD1680	SCREW	1	SILVER
2	VMP8406	TRIPOD PLATE	1		B30	VHD1684	SCREW	1	BLACK
3	VMD5360	TRIPOD SCREW	1		B30	VHD1680	SCREW	1	SILVER
4	VYF3034	BATTERY COVER UNIT	1	BLACK	B32	VHD1684	SCREW	1	BLACK
4	VYF3043	BATTERY COVER UNIT	1	SILVER	B32	VHD1680	SCREW	1	SILVER
5	VMS7608	BATTERY HINGE SHAFT	1		B33	VHD1684	SCREW	1	BLACK
6	VMB3971	BATTERY COVER HINGE SPRING	1		B33	VHD1680	SCREW	1	SILVER
7	VMB3977	BATTERY SPRING	1		B40	VHD1680	SCREW	1	
8	VGU9817	BATTERY LOCK KNOB	1		B41	VHD1680	SCREW	1	
9	VMB3970	BATTERY LOCK SPRING	1		B42	XQN16+B4FN	SCREW	1	
10	VMS7612	BATTERY LOCK SHAFT	1		B47	XQN16+BJ5FN	SCREW	1	
11	VGQ8465	BATTERY CASE	1		B48	XQN16+BJ5FN	SCREW	1	
21	VYK1S99	TOP CASE UNIT	1	BLACK	B49	XQN16+BJ5FN	SCREW	1	
21	VYK1T00	TOP CASE UNIT	1	SILVER	B51	VHD1829	SCREW	1	BLACK
23	VKW3282	LED SHADE PANEL	1		B51	XQN16+BJ6FN	SCREW	1	SILVER
24	VGQ8474	LED SHADE	1		B53	XQN16+B4FN	SCREW	1	BLACK
25	VEP59016A	AF ASSIST C.B.A.	1	[RTL]	B53	XQN16+B4FJK	SCREW	1	SILVER
26	VKW3283	POWER LED PANEL	1		B54	XQN16+B4FN	SCREW	1	BLACK
27	VGU9504	POWER KNOB	1	BLACK	B54	XQN16+B4FJK	SCREW	1	SILVER
27	VGU9870	POWER KNOB	1	SILVER	B60	VHD1684	SCREW	1	
28	KORB01600002	TOP OPERATION UNIT	1						
29	VGQ8480	STRAP HOLDER R	1						
30	VGQ8475	MIC DUMPPER HOLDER	1						
31	VYQ3474	MIC FPC UNIT	1						
31-1	WM-64MNT506	MIC	1						
32	VMT1694	MIC DUMPPER	1						
33	KOF111F00008	FLASH SW UNIT	1						
35	VMS7610	FLASH SHAFT	1						
36	VKM6760	FLASH CASE BOTTOM	1	BLACK					
36	VKM6802	FLASH CASE BOTTOM	1	SILVER					
37	VMP8409	FLASH EARTH PLATE	1						
38	VEKOH68	FLASH UNIT	1						
39	VMB3974	FLASH SPRING	1						
40	VKM6759	FLASH CASE TOP	1	BLACK					
40	VKM6766	FLASH CASE TOP	1	SILVER					
41	VGQ8487	GEAR COVER	1	BLACK					
41	VGQ8508	GEAR COVER	1	SILVER					
42	VMC1768	SHOE SPRING	1	BLACK					
42	VMC1752	SHOE SPRING	1	SILVER					
43	VEP56025A	MAIN C.B.A.	1	[RTL]					
47	VYQ3463	JACK DOOR UNIT	1	BLACK					
47	VYQ3477	JACK DOOR UNIT	1	SILVER					
48	VEP58014A	FLASH C.B.A.	1	[RTL]					
49	VGQ8463	CONDENSOR HOLDER	1						
50	VJB58015	FLASH IF F.P.C.	1						
51	VYQ3504	BATTERY CATCHER UNIT	1						
68	VGQ8481	STRAP HOLDER L	1						
69	VGQ8541	LCD HOLDER	1						
70	VGQ8557	EVF LCD CUSHION	1						
71	VYQ3465	EVF UNIT	1						
72	LS5EDDXM00002	EVF LCD UNIT	1						
73	VGQ8688	BARRIER CUSHION	1						
B1	VHD1684	SCREW	1	BLACK					
B1	VHD1680	SCREW	1	SILVER					
B2	VHD1684	SCREW	1	BLACK					
B2	VHD1680	SCREW	1	SILVER					
B7	VHD1687	SCREW	1						
B8	XQN16+BJ5FJK	SCREW	1	BLACK					
B8	XQN16+BJ5FN	SCREW	1	SILVER					
B9	XQN16+BJ5FJK	SCREW	1	BLACK					
B9	XQN16+BJ5FN	SCREW	1	SILVER					
B12	XQN16+BJ5FN	SCREW	1						
B13	XQN16+BJ5FN	SCREW	1						
B16	XQN16+BJ5FN	SCREW	1						
B17	XQN16+BJ5FN	SCREW	1						
B18	XQN16+BJ5FN	SCREW	1						
B19	XQN16+BJ5FN	SCREW	1						
B20	XQN16+BJ5FN	SCREW	1						
B22	VHD1684	SCREW	1	BLACK					
B22	VHD1680	SCREW	1	SILVER					
B25	VHD1684	SCREW	1	BLACK					
B25	VHD1680	SCREW	1	SILVER					

DMC-FZ30PP/PL/EB/EG/EGM/GC/GD/GK/GN/GT/SG
M2

Ref.No.	Part No.	Part Name & Description	Pcs	Remarks	Ref.No.	Part No.	Part Name & Description	Pcs	Remarks
12	VYK1S95	REAR CASE UNIT	1	BLACK					
12	VYK1S96	REAR CASE UNIT	1	SILVER					
13	VGQ8533	EVF COVER CUSHION	1						
15	VMP8401	REAR OP PLATE	1						
16	LOAA01A00019	SPEAKER	1						
17	VGQ8472	CROSS KEY BUTTON	1	BLACK					
17	VGQ8501	CROSS KEY BUTTON	1	SILVER					
18	VGQ8471	REAR OP BUTTON	1	BLACK					
18	VGQ8500	REAR OP BUTTON	1	SILVER					
19	VGQ8542	R PIECE	1	BLACK					
19	VGQ8560	R PIECE	1	SILVER					
20	VGQ8542	R PIECE	1	BLACK					
20	VGQ8560	R PIECE	1	SILVER					
52	VYF3037	SD DOOR UNIT	1	BLACK					
52	VYF3045	SD DOOR UNIT	1	SILVER					
53	VG6135	LCD CASE BOTTOM	1	BLACK					
53	VG6138	LCD CASE BOTTOM	1	SILVER					
54	VMT1701	LCD CUSION	1						
55	VMT1701	LCD CUSION	1						
56	VMA0112	LCD SHIELD	1						
57	VEP54003A	LCD IF C.B.A.	1	[RTL]					
58	VGQ8468	HINGE COVER BOTTOM	1	BLACK					
58	VGQ8504	HINGE COVER BOTTOM	1	SILVER					
59	VGQ8467	HINGE COVER UP	1	BLACK					
59	VGQ8505	HINGE COVER UP	1	SILVER					
60	VYF3070	LCD CASE UNIT	1	BLACK					
60	VYF3071	LCD CASE UNIT	1	SILVER					
61	VYQ3473	LCD UNIT	1						
62	VGQ8547	FPC RUBBER	1						
63	VGQ8469	HINGE ARM COVER	1	BLACK					
63	VGQ8506	HINGE ARM COVER	1	SILVER					
64	VYF3036	LCD HINGE (1) UNIT	1						
SIW4801	KOL1BA000102	SW	1						
65	VMA0779	LCD FPC PLATE	1						
66	VMB3988	SW LEVER SPRING	1						
67	VGQ8624	LCD SW LEVER	1	BLACK					
67	VGQ8625	LCD SW LEVER	1	SILVER					
B4	XQN16+BJ45FN	SCREW	1						
B5	XQN16+BJ45FN	SCREW	1						
B6	XQN16+BJ45FN	SCREW	1						
B23	VHD1684	SCREW	1	BLACK					
B23	VHD1680	SCREW	1	SILVER					
B24	VHD1684	SCREW	1	BLACK					
B24	VHD1680	SCREW	1	SILVER					
B26	VHD1684	SCREW	1	BLACK					
B26	VHD1680	SCREW	1	SILVER					
B28	VHD1684	SCREW	1	BLACK					
B28	VHD1680	SCREW	1	SILVER					
B29	VHD1684	SCREW	1	BLACK					
B29	VHD1680	SCREW	1	SILVER					
B31	VHD1684	SCREW	1	BLACK					
B31	VHD1680	SCREW	1	SILVER					
B43	XQN16+BJ4FJK	SCREW	1						
B44	VHD1819	SCREW	1	BLACK					
B44	VHD1685	SCREW	1	SILVER					
B45	VHD1819	SCREW	1	BLACK					
B45	VHD1685	SCREW	1	SILVER					
B46	VHD1819	SCREW	1	BLACK					
B46	VHD1685	SCREW	1	SILVER					
B50	VHD1829	SCREW	1	BLACK					
B50	XQN16+BJ6FN	SCREW	1	SILVER					
B52	VHD1829	SCREW	1	BLACK					
B52	XQN16+BJ6FN	SCREW	1	SILVER					
B55	XQN16+BJ5FN	SCREW	1						
B56	XQN16+BJ5FN	SCREW	1						
B57	XQN16+BJ5FN	SCREW	1						
B58	XQN16+BJ5FN	SCREW	1						
B59	XQN16+BJ5FN	SCREW	1						

DMC-FZ30PP/PL/EB/EG/EGM/GC/GD/GK/GN/GT/SG
M3

Ref.No.	Part No.	Part Name & Description	Pcs	Remarks	Ref.No.	Part No.	Part Name & Description	Pcs	Remarks
44	N9Z00000309	SIDE OPERATION UNIT	1	BLACK					
44	N9Z00000308	SIDE OPERATION UNIT	1	SILVER					
101	VMG1689	ZOOM RUBBER RING	1	[PAVC-CSG]					
102	VDW1180	LENS RING FRONT	1	[PAVC-CSG] BLACK					
102	VDW1215	LENS RING FRONT	1	[PAVC-CSG] SILVER					
103	VDP1886	ZOOM RING	1	[PAVC-CSG] BLACK					
103	VDP1885	ZOOM RING	1	[PAVC-CSG] SILVER					
104	VXP2485	MF RING UNIT	1	[PAVC-CSG] BLACK					
104	VXP2523	MF RING UNIT	1	[PAVC-CSG] SILVER					
105	VMG1690	FOCUS RUBBER RING	1	[PAVC-CSG]					
108	VDW1181	LENS RING BASE	1	[PAVC-CSG] BLACK					
108	VDW1216	LENS RING BASE	1	[PAVC-CSG] SILVER					
109	VXQ1340	1ST LENS FRAME UNIT	1	[PAVC-CSG]					
112	VDW1169	OUTSIDE FRAME	1	[PAVC-CSG]					
113	VEQ4514	ZOOM ENCODER UNIT	1	[PAVC-CSG]					
114	VXP2486	CAM FRAME UNIT	1	[PAVC-CSG]					
119	VXP2471	2ND LENS FRAME UNIT	1	[PAVC-CSG]					
125	VXQ1341	3RD LENS FRAME UNIT	1	[PAVC-CSG]					
126	VXP2474	4TH LENS FRAME UNIT	1	[PAVC-CSG]					
129	VMX3484	THRUST RING	1	[PAVC-CSG]					
130	VMX3476	WAVE WASHER	1	[PAVC-CSG]					
131	VDW1172	INSIDE FRAME	1	[PAVC-CSG]					
132	VXP2476	5TH LENS FRAME UNIT	1	[PAVC-CSG]					
134	VMS7620	F GUIDE POLE S	1	[PAVC-CSG]					
135	VDW1173	MASTER FLANGE	1	[PAVC-CSG]					
136	08S1E13F6NM	FOCUS MOTOR UNIT	1	[PAVC-CSG]					
137	VDL1726	OPTICAL FILTER	1	[PAVC-CSG]					
138	VMX3480-1	CCD CUSHION	1	[PAVC-CSG]					
139	VEKOJ07	CCD C.B.A.	1	[PAVC-CSG]					
140	VMS7605	F GUIDE POLE L	1	[PAVC-CSG]					
141	VMS7600	Z GUIDE POLE	1	[PAVC-CSG]					
142	VMS7600	Z GUIDE POLE	1	[PAVC-CSG]					
143	VMS7600	Z GUIDE POLE	1	[PAVC-CSG]					
144	VGH4844	DECORATION RING	1	[PAVC-CSG]					
147	VEKOJ06	LENS FPC UNIT	1	[PAVC-CSG]					
147-1	B3NAA0000074	PHOTO-COUPLER	1	[PAVC-CSG]					
148	VMS7602	ZOOM DRIVE PIN	1	[PAVC-CSG]					
150	VXW0723	LENS UNIT (W/O CCD)	1	[PAVC-CSG] BLACK					
150	VXW0737	LENS UNIT (W/O CCD)	1	[PAVC-CSG] SILVER					
B34	VHD1808	SCREW	1						
B35	VHD1808	SCREW	1						
B36	VHD1808	SCREW	1						
B37	VHD1808	SCREW	1						
B38	VHD1564	SCREW	1						
B39	VHD1564	SCREW	1						
B101	XQN14+CJ3FN	SCREW	1	[PAVC-CSG]					
B102	XQN14+CJ3FN	SCREW	1	[PAVC-CSG]					
B103	XQN14+CJ3FN	SCREW	1	[PAVC-CSG]					
B104	XQN16+C8FN	SCREW	1	[PAVC-CSG]					
B105	XQN16+C8FN	SCREW	1	[PAVC-CSG]					
B106	XQN16+C8FN	SCREW	1	[PAVC-CSG]					
B107	XQN16+CJ3FN	SCREW	1	[PAVC-CSG]					
B111	XQN16+CJ5FN	SCREW	1	[PAVC-CSG]					
B112	XQN16+CJ5FN	SCREW	1	[PAVC-CSG]					
B113	XQN16+CJ5FN	SCREW	1	[PAVC-CSG]					
B114	XQN16+CJ5FN	SCREW	1	[PAVC-CSG]					
B115	XQN16+CJ5FN	SCREW	1	[PAVC-CSG]					
B116	XQN16+CJ5FN	SCREW	1	[PAVC-CSG]					
B117	XQN16+CJ5FN	SCREW	1	[PAVC-CSG]					
B118	XQN16+CJ5FN	SCREW	1	[PAVC-CSG]					
B119	XQN16+CJ5FN	SCREW	1	[PAVC-CSG]					
B120	XQN16+CJ5FN	SCREW	1	[PAVC-CSG]					
B121	XQN16+CJ5FN	SCREW	1	[PAVC-CSG]					
B122	XQN16+CJ5FN	SCREW	1	[PAVC-CSG]					
B123	XQN16+CJ5FN	SCREW	1	[PAVC-CSG]					
B124	XQN16+CJ5FN	SCREW	1	[PAVC-CSG]					
B125	XQN16+CJ5FN	SCREW	1	[PAVC-CSG]					
B126	XQN16+CJ5FN	SCREW	1	[PAVC-CSG]					
B127	XQN16+CJ5FN	SCREW	1	[PAVC-CSG]					
B128	XQN16+CJ5FN	SCREW	1	[PAVC-CSG]					
B129	XQN16+CJ5FN	SCREW	1	[PAVC-CSG]					

DMC-FZ30PP/PL/EB/EG/EGM/GC/GD/GK/GN/GT/SG
M4

Ref.No.	Part No.	Part Name & Description	Pcs	Remarks
△ 202	-----	BATTERY	1	
△ 203	DE-993BB	AC ADAPTOR	1	DMC-FZ30PP/PL
△ 203	DE-994AB	AC ADAPTOR	1	DMC-FZ30EG/EGM/EB/GN
△ 203	DE-994BA	AC ADAPTOR	1	DMC-FZ30GC/SG/GK/GD
△ 203	DE-994CA	AC ADAPTOR	1	DMC-FZ30GT
204	K1HA08CD0007	USB CABLE W/PLUG	1	[PAVC-CSG]
205	K1HA08CD0008	AV CABLE W/PLUG	1	[PAVC-CSG]
206	VFC4124	SHOULDER BELT	1	
207	VFF0293-S	CD-ROM	1	[PAVC-CSG] DMC-FZ30PP
207	VFF0294-S	CD-ROM	1	[PAVC-CSG] DMC-FZ30PL/EG/EGM/EB /GC/SG/GT/GK/GN/GD
209	VPF1100	BAG, POLYETHYLENE	1	[PAVC-CSG] DMC-FZ30PP/EB/ /GT/GK/GN/GD
209	VPF1132	BAG, POLYETHYLENE	1	[PAVC-CSG] DMC-FZ30PL/EG/EGM/GC/SG
△ 210	VQTOR81	INSTRUCTION BOOK (ENGLISH)	1	[PAVC-CSG] DMC-FZ30PP
△ 210	VQTOR82	INSTRUCTION BOOK (CANADIAN FRENCH)	1	[PAVC-CSG] DMC-FZ30PP
△ 210	VQTOR85	INSTRUCTION BOOK (SPANISH)	1	[PAVC-CSG] DMC-FZ30PL
△ 210	VQTOR86	INSTRUCTION BOOK (PORTUGUESE)	1	[PAVC-CSG] DMC-FZ30PL
△ 210	VQTOR84	INSTRUCTION BOOK (ENGLISH)	1	[PAVC-CSG] DMC-FZ30PL
△ 210	VQTOR90	INSTRUCTION BOOK (ITALIAN)	1	[PAVC-CSG] DMC-FZ30EG
△ 210	VQTOR88	INSTRUCTION BOOK (GERMAN)	1	[PAVC-CSG] DMC-FZ30EG
△ 210	VQTOR89	INSTRUCTION BOOK (FRENCH)	1	[PAVC-CSG] DMC-FZ30EG
△ 210	VQTOR91	INSTRUCTION BOOK (DUTCH)	1	[PAVC-CSG] DMC-FZ30EG
△ 210	VQTOR96	INSTRUCTION BOOK (SWEDISH)	1	[PAVC-CSG] DMC-FZ30EGM
△ 210	VQTOR94	INSTRUCTION BOOK (SPANISH)	1	[PAVC-CSG] DMC-FZ30EGM
△ 210	VQTOR95	INSTRUCTION BOOK (PORTUGUESE)	1	[PAVC-CSG] DMC-FZ30EGM
△ 210	VQTOR97	INSTRUCTION BOOK (DANISH)	1	[PAVC-CSG] DMC-FZ30EGM
△ 210	VQTO900	INSTRUCTION BOOK (ENGLISH)	1	[PAVC-CSG] DMC-FZ30EB
△ 210	VQTO904	INSTRUCTION BOOK (RUSSIAN)	1	[PAVC-CSG] DMC-FZ30GC/SG
△ 210	VQTO902	INSTRUCTION BOOK (ENGLISH)	1	[PAVC-CSG] DMC-FZ30GC/SG
△ 210	VQTO903	INSTRUCTION BOOK (CHINESE (TRADITIONAL))	1	[PAVC-CSG] DMC-FZ30GC/SG
△ 210	VQTO905	INSTRUCTION BOOK (ARABIC)	1	[PAVC-CSG] DMC-FZ30GC/SG
△ 210	VQTO908	INSTRUCTION BOOK (CHINESE (TRADITIONAL))	1	[PAVC-CSG] DMC-FZ30GT
△ 210	VQTO910	INSTRUCTION BOOK (CHINESE (SIMPLIFIED))	1	[PAVC-CSG] DMC-FZ30GK
△ 210	VQTO912	INSTRUCTION BOOK (ENGLISH)	1	[PAVC-CSG] DMC-FZ30GN
△ 210	VQTO914	INSTRUCTION BOOK (KOREAN)	1	[PAVC-CSG] DMC-FZ30GD
211	VQTOU14	INSTRUCTION BOOK/PC CONN (ENGLISH/CANADIAN FRENCH)	1	[PAVC-CSG] DMC-FZ30PP
211	VQTOU15	INSTRUCTION BOOK/PC CONN (ENGLISH/SPANISH/ PORTUGUESE)	1	[PAVC-CSG] DMC-FZ30PL
211	VQTOU16	INSTRUCTION BOOK/PC CONN (GERMAN/FRENCH)	1	[PAVC-CSG] DMC-FZ30EG
211	VQTOU18	INSTRUCTION BOOK/PC CONN (SPANISH/PORTUGUESE)	1	[PAVC-CSG] DMC-FZ30EGM
211	VQTOU19	INSTRUCTION BOOK/PC CONN (ENGLISH)	1	[PAVC-CSG] DMC-FZ30EB
211	VQTOU20	INSTRUCTION BOOK/PC CONN	1	[PAVC-CSG] DMC-FZ30GC/SG

Ref.No.	Part No.	Part Name & Description	Pcs	Remarks
		(ENGLISH/ CHINESE (TRADITIONAL))		
211	VQTOU21	INSTRUCTION BOOK/PC CONN (CHINESE (TRADITIONAL))	1	[PAVC-CSG] DMC-FZ30GT
211	VQTOU22	INSTRUCTION BOOK/PC CONN (CHINESE (SIMPLIFIED))	1	[PAVC-CSG] DMC-FZ30GK
211	VQTOU23	INSTRUCTION BOOK/PC CONN (ENGLISH)	1	[PAVC-CSG] DMC-FZ30GN
211	VQTOU24	INSTRUCTION BOOK/PC CONN (KOREAN)	1	[PAVC-CSG] DMC-FZ30GD
212	VQTO986	O/I SOFTWARE (ENGLISH/CANADIAN FRENCH)	1	[PAVC-CSG] DMC-FZ30PP
212	VQTO987	O/I SOFTWARE (ENGLISH/SPANISH/ PORTUGUESE)	1	[PAVC-CSG] DMC-FZ30PL
212	VQTO988	O/I SOFTWARE (GERMAN/FRENCH/ITALIAN/ DUTCH)	1	[PAVC-CSG] DMC-FZ30EG
212	VQTO989	O/I SOFTWARE (SPANISH/PORTUGUESE/ SWEDISH/DANISH)	1	[PAVC-CSG] DMC-FZ30EGM
212	VQTO990	O/I SOFTWARE (ENGLISH)	1	[PAVC-CSG] DMC-FZ30EB
212	VQTO991	O/I SOFTWARE (ENGLISH/ CHINESE (TRADITIONAL)/ ARABIC/RUSSIAN)	1	[PAVC-CSG] DMC-FZ30GC/SG
212	VQTO992	O/I SOFTWARE (CHINESE (TRADITIONAL))	1	[PAVC-CSG] DMC-FZ30GT
212	VQTO993	O/I SOFTWARE (CHINESE (SIMPLIFIED))	1	[PAVC-CSG] DMC-FZ30GK
212	VQTO994	O/I SOFTWARE (ENGLISH)	1	[PAVC-CSG] DMC-FZ30GN
212	VQTO995	O/I SOFTWARE (KOREAN)	1	[PAVC-CSG] DMC-FZ30GD
213	VYK1P30	LENS CAP UNIT	1	
214	VYQ3505	LENS HOOD UNIT	1	
215	VPF1193	BAG, POLYETHYLENE	1	
217	VPK3047	INNER CARTON	1	DMC-FZ30PP (BLACK)
217	VPK3043	INNER CARTON	1	DMC-FZ30PP (SILVER)
217	VPK3048	INNER CARTON	1	DMC-FZ30PL/EG/EGM/EB /GC/SG/GT/GN/GD (BLACK)
217	VPK3044	INNER CARTON	1	DMC-FZ30PL/EG/EGM/EB /GC/SG/GT/GN/GD (SILVER)
217	VPK3049	INNER CARTON	1	DMC-FZ30GK (BLACK)
217	VPK3045	INNER CARTON	1	DMC-FZ30GK (SILVER)
218	VPN6358	TRAY	1	
219	VPK3058	ACCESSORY BOX	1	DMC-FZ30PP
219	VPK3059	ACCESSORY BOX	1	DMC-FZ30PL/EG/EGM/EB /GC/SG/GT/GK/GN/GD
220	RP-SD032BVE0	SD CARD	1	
221	VPF1214	SD CARD BAG, POLYETHYLENE	1	
△ 222	K2C02CA00006	AC CORD W/PLUG	1	DMC-FZ30EG/EGM/GC/SG K2CR2DA00004
△ 223	RJA0053-3X	AC CORD W/PLUG	1	DMC-FZ30EB/GC/SG
△ 224	K2CA2CA00027	AC CORD W/PLUG	1	DMC-FZ30GT
△ 225	K2CA2CA00020	AC CORD W/PLUG	1	DMC-FZ30GK
△ 226	K2CJ2DA00008	AC CORD W/PLUG	1	DMC-FZ30GN
△ 227	RJA0078-1X	AC CORD W/PLUG	1	DMC-FZ30GD

S6. EXPLODED VIEWS

S6.1. FRAME & CASING SECTION (1)

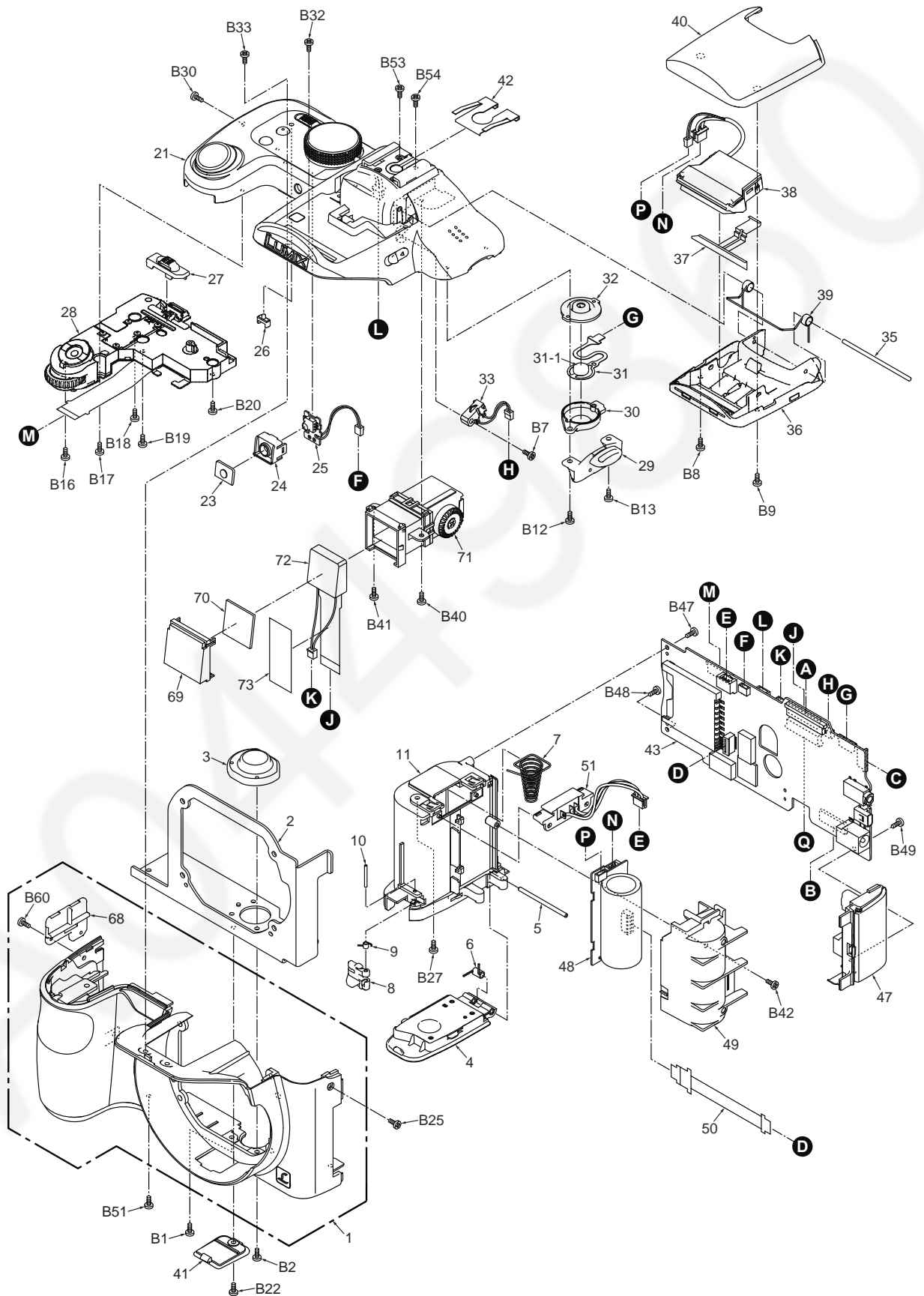

S6.2. FRAME & CASING SECTION (2)

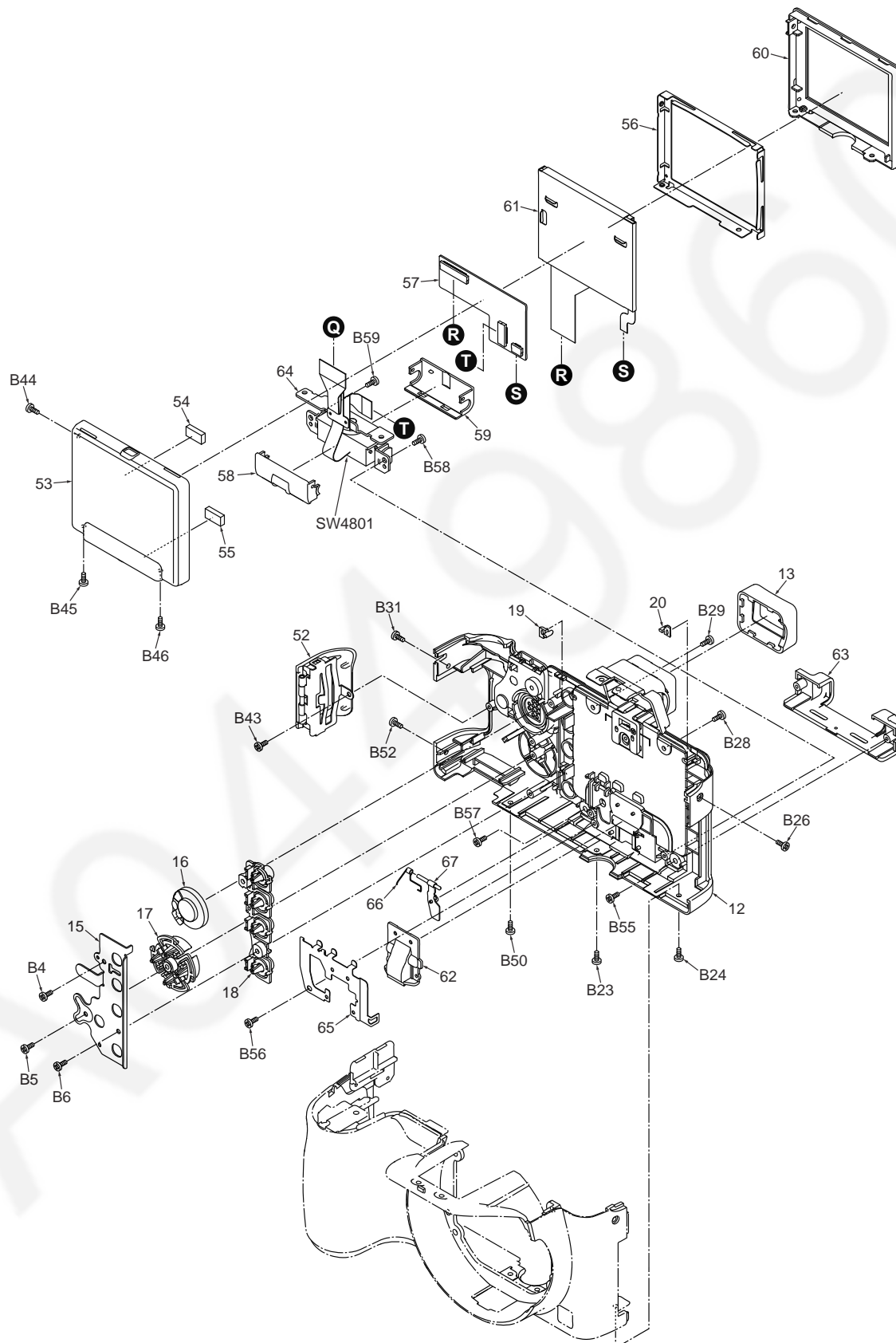

S6.3. FRAME & CASING SECTION (3)

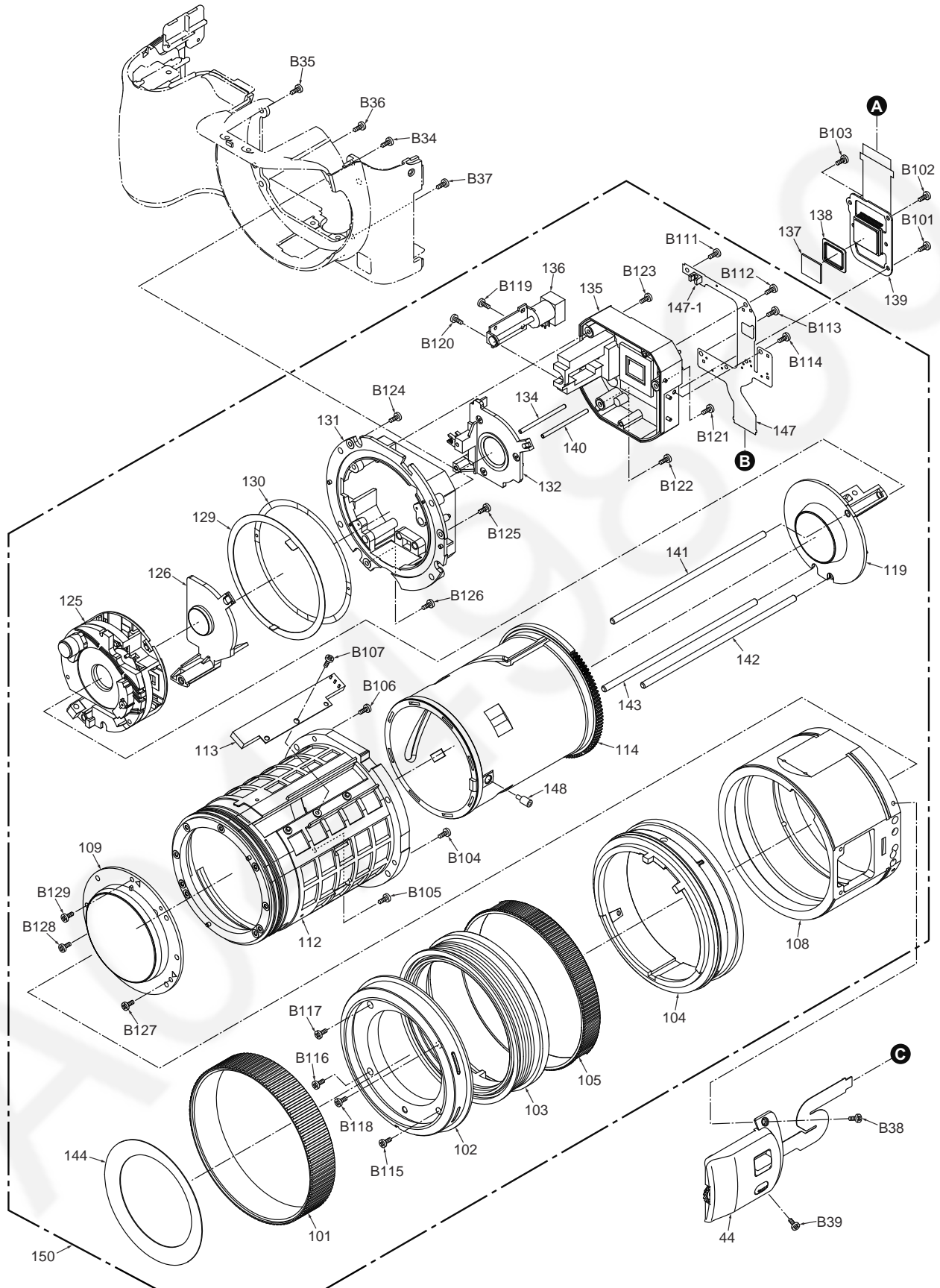

S6.4. PACKING PARTS & ACCESSORIES SECTION

