

**Panasonic®****ORDER NO. DSC1611018CE****B26**

# Service Manual

## Digital Camera

Model No. **DMC-FZ2000EB**  
**DMC-FZ2000EF**  
**DMC-FZ2000EG**  
**DMC-FZ2000EP**  
**DMC-FZ2500P**  
**DMC-FZ2500PP**  
**DMC-FZ2500GA**  
**DMC-FZ2500GC**  
**DMC-FZ2500GD**  
**DMC-FZ2500GH**  
**DMC-FZ2500GK**  
**DMC-FZ2500GN**

**Colour**  
**Black Type**

**LUMIX**

 **WARNING**

This service information is designed for experienced repair technicians only and is not designed for use by the general public. It does not contain warnings or cautions to advise non-technical individuals of potential dangers in attempting to service a product. Products powered by electricity should be serviced or repaired only by experienced professional technicians. Any attempt to service or repair the product or products dealt with in this service information by anyone else could result in serious injury or death.

© Panasonic Corporation 2016 Unauthorized copying and distribution is a violation of law.

# 1 Safety Precautions

## 1.1 General Guidelines

### 1. IMPORTANT SAFETY NOTICE

- There are special components used in this equipment which are important for safety. These parts are marked by  in the Schematic Diagrams, Circuit Board Layout, Exploded Views and Replacement Parts List. It is essential that these critical parts should be replaced with manufacturer's specified parts to prevent X-RADIATION, shock, fire, or other hazards. Do not modify the original design without permission of manufacturer.
2. An Isolation Transformer should always be used during the servicing of AC Adaptor whose chassis is not isolated from the AC power line. Use a transformer of adequate power rating as this protects the technician from accidents resulting in personal injury from electrical shocks. It will also protect AC Adaptor from being damaged by accidental shorting that may occur during servicing.
  3. When servicing, observe the original lead dress. If a short circuit is found, replace all parts which have been overheated or damaged by the short circuit.
  4. After servicing, see to it that all the protective devices such as insulation barriers, insulation papers shields are properly installed.
  5. After servicing, make the following leakage current checks to prevent the customer from being exposed to shock hazards.

## 1.2 Leakage Current Cold Check

1. Unplug the AC cord and connect a jumper between the two prongs on the plug.
2. Measure the resistance value, with an ohmmeter, between the jumpered AC plug and each exposed metallic cabinet part on the equipment such as screwheads, connectors, control shafts, etc. When the exposed metallic part has a return path to the chassis, the reading should be between 1 M $\Omega$  and 5.2 M $\Omega$ . When the exposed metal does not have a return path to the chassis, the reading must be infinity.

## 1.3 Leakage Current Hot Check (See Figure. 1)

1. Plug the AC cord directly into the AC outlet. Do not use an isolation transformer for this check.
2. Connect a 1.5 k $\Omega$ , 10 W resistor, in parallel with a 0.15  $\mu$ F capacitor, between each exposed metallic part on the set and a good earth ground, as shown in Figure. 1.
3. Use an AC voltmeter, with 1 k $\Omega$ /V or more sensitivity, to measure the potential across the resistor.
4. Check each exposed metallic part, and measure the voltage at each point.
5. Reverse the AC plug in the AC outlet and repeat each of the above measurements.
6. The potential at any point should not exceed 0.75 V RMS. A leakage current tester (Simpson Model 229 or equivalent) may be used to make the hot checks, leakage current must not exceed 1/2 mA. In case a measurement is outside of the limits specified, there is a possibility of a shock hazard, and the equipment should be repaired and rechecked before it is returned to the customer.

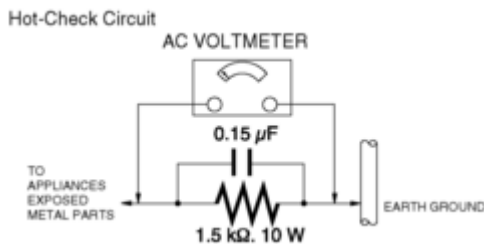

Figure. 1

## 1.4 How to Discharge the E.Capacitor on Flash P.C.B. Unit

### CAUTION:

- Be sure to discharge the E.Capacitor on Flash P.C.B. Unit before disassembling.
- Be careful of the high voltage circuit on Flash P.C.B. Unit when servicing.

### [Discharging procedure]

1. Put the insulation tube on the lead part of resistor (ERG5SJ102: 1k $\Omega$  / 5W).  
(An equivalent type of resistor may be used.)
2. Put the resistor between both terminals of E.Capacitor on the Flash P.C.B. Unit for approx. 5 seconds.
3. After discharging, confirm that the E.Capacitor voltage is lower than 10V by using a voltmeter.

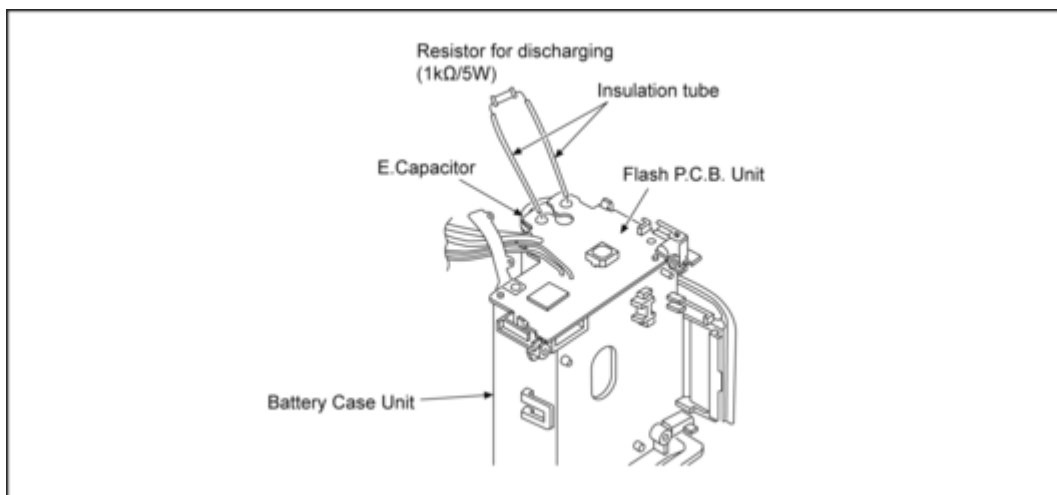

Fig. F1

## 2 Warning

### 2.1 Prevention of Electrostatic Discharge (ESD) to Electrostatically Sensitive (ES) Devices



Some semiconductor (solid state) devices can be damaged easily by static electricity. Such components commonly are called Electrostatically Sensitive (ES) Devices.

Examples of typical ES devices are MOS image sensor, IC (integrated circuits) and some field-effect transistors and semiconductor "chip" components.

The following techniques should be used to help reduce the incidence of component damage caused by electrostatic discharge (ESD).

1. Immediately before handling any semiconductor component or semiconductor-equipped assembly, drain off any ESD on your body by touching a known earth ground. Alternatively, obtain and wear a commercially available discharging ESD wrist strap, which should be removed for potential shock reasons prior to applying power to the unit under test.
2. After removing an electrical assembly equipped with ES devices, place the assembly on a conductive surface such as aluminum foil, to prevent electrostatic charge buildup or exposure of the assembly.
3. Use only a grounded-tip soldering iron to solder or unsolder ES devices.
4. Use only an antistatic solder removal device. Some solder removal devices not classified as "antistatic (ESD protected)" can generate electrical charge sufficient to damage ES devices.
5. Do not use freon-propelled chemicals. These can generate electrical charges sufficient to damage ES devices.
6. Do not remove a replacement ES device from its protective package until immediately before you are ready to install it. (Most replacement ES devices are packaged with leads electrically shorted together by conductive foam, aluminum foil or comparable conductive material).
7. Immediately before removing the protective material from the leads of a replacement ES device, touch the protective material to the chassis or circuit assembly into which the device will be installed.  
**CAUTION :**  
Be sure no power is applied to the chassis or circuit, and observe all other safety precautions.
8. Minimize bodily motions when handling unpackaged replacement ES devices. (Otherwise harmless motion such as the brushing together of your clothes fabric or the lifting of your foot from a carpeted floor can generate static electricity (ESD) sufficient to damage an ES device).

### 2.2 How to Recycle the Lithium Ion Battery (U.S. Only)

<b>ENGLISH</b>		<p>A lithium ion battery that is recyclable powers the product you have purchased. Please call 1-800-8-BATTERY for information on how to recycle this battery.</p>
<b>FRANÇAIS</b>		<p>L'appareil que vous vous êtes procuré est alimenté par une batterie au lithium-ion recyclable. Pour des renseignements sur le recyclage de la batterie, veuillez composer le 1-800-8-BATTERY.</p>

## 2.3 How to Replace the Lithium Battery

### 2.3.1 Replacement Procedure

1. Remove the Flash P.C.B. Unit. (Refer to Disassembly Procedures.)
2. Unsolder the each soldering point of electric lead terminal for Lithium battery (Ref. No. "B8001" at component side of Flash P.C.B. Unit) and remove the Lithium battery together with electric lead terminal. Then replace it into new one.

**NOTE:**

The Lithium battery includes electric lead terminals.

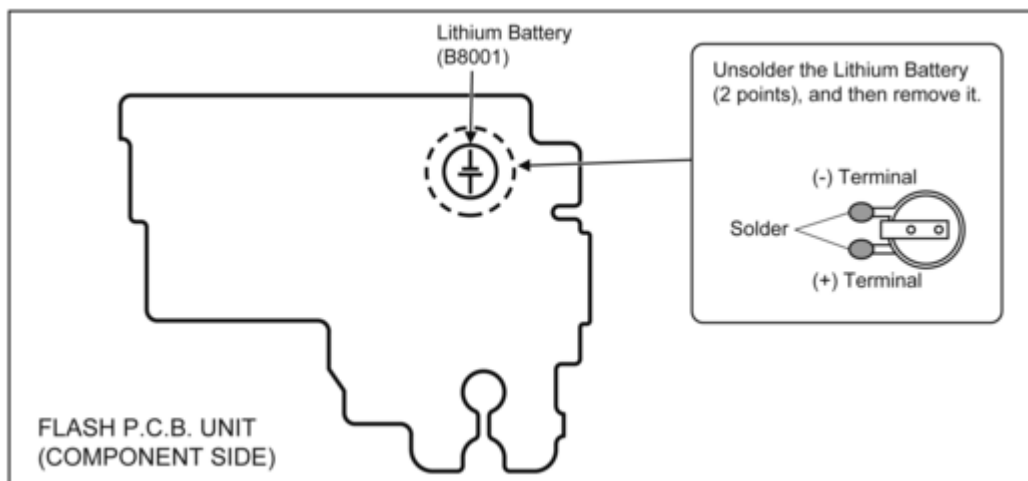

**NOTE:**

This Lithium battery is a critical component.

It must never be subjected to excessive heat or discharge.

It must therefore only be fitted in requirement designed specifically for its use.

Replacement batteries must be of same type and manufacture.

They must be fitted in the same manner and location as the original battery, with the correct polarity contacts observed.

Do not attempt to re-charge the old battery or re-use it for any other purpose.

It should be disposed of in waste products destined for burial rather than incineration.

(For English)

### CAUTION

Danger of explosion if battery is incorrectly replaced. Replace only with the same or equivalent type recommended by the manufacturer. Dispose of used batteries according to the manufacturer's instructions.

(For German)

### ACHTUNG

Explosionsgefahr bei falschem Anbringen der Batterie. Ersetzen Sie nur mit einem äquivalentem vom Hersteller empfohlenem Typ.  
Behandeln Sie gebrauchte Batterien nach den Anweisungen des Herstellers.

(For French)

### MISE EN GARDE

Une batterie de remplacement inappropriée peut exploser. Ne remplacez qu' avec une batterie identique ou d' un type recommandé par le fabricant. L' élimination des batteries usées doit être faite conformément aux instructions du manufacturier.

**NOTE:**

Above caution is applicable for a battery pack which is for DMC-FZ2000/FZ2500 series, as well.

## 2.4 Caution for AC Cord (For EB/GC/GH)

### 2.4.1 Information for Your Safety

**IMPORTANT**

Your attention is drawn to the fact that recording of pre-recorded tapes or discs or other published or broadcast material may infringe copyright laws.

**WARNING**

To reduce the risk of fire or shock hazard, do not expose this equipment to rain or moisture.

**CAUTION**

To reduce the risk of fire or shock hazard and annoying interference, use the recommended accessories only.

**FOR YOUR SAFETY**

**DO NOT REMOVE THE OUTER COVER**

To prevent electric shock, do not remove the cover. No user serviceable parts inside. Refer servicing to qualified service personnel.

### 2.4.2 Caution for AC Mains Lead

For your safety, please read the following text carefully.

This appliance is supplied with a moulded three-pin mains plug for your safety and convenience.

A 5-ampere fuse is fitted in this plug.

Should the fuse need to be replaced please ensure that the replacement fuse has a rating of 5 amperes and it is approved by ASTA or BSI to BS1362

Check for the ASTA mark or the BSI mark on the body of the fuse.



If the plug contains a removable fuse cover you must ensure that it is refitted when the fuse is replaced.

If you lose the fuse cover, the plug must not be used until a replacement cover is obtained.

A replacement fuse cover can be purchased from your local Panasonic Dealer.

If the fitted moulded plug is unsuitable for the socket outlet in your home then the fuse should be removed and the plug cut off and disposed of safely.

There is a danger of severe electrical shock if the cut off plug is inserted into any 13-ampere socket.

If a new plug is to be fitted please observe the wiring code as shown below.

If in any doubt, please consult a qualified electrician.

### 2.4.2.1 Important

The wires in this mains lead are coloured in accordance with the following code:

Blue	Neutral
Brown	Live

As the colours of the wires in the mains lead of this appliance may not correspond with the coloured markings identifying the terminals in your plug, proceed as follows:

The wire which is coloured BLUE must be connected to the terminal in the plug which is marked with the letter N or coloured BLACK.

The wire which is coloured BROWN must be connected to the terminal in the plug which is marked with the letter L or coloured RED.

Under no circumstances should either of these wires be connected to the earth terminal of the three pin plug, marked with the letter E or the Earth Symbol.

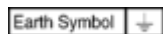

### 2.4.2.2 Before Use

Remove the Connector Cover as follows.

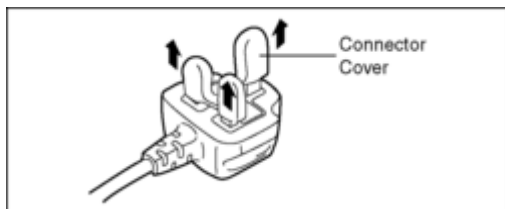

### 2.4.2.3 How to Replace the Fuse

1. Remove the Fuse Cover with a screwdriver.

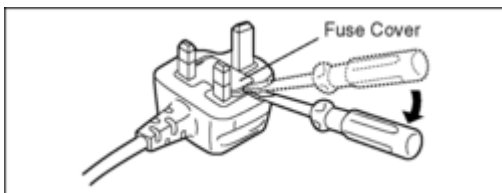

2. Replace the fuse and attach the Fuse cover.

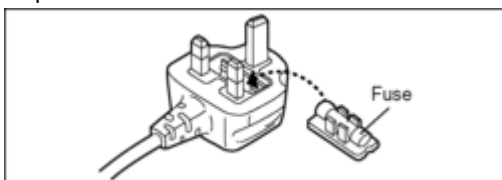



# 3 Service Navigation

## 3.1 Introduction

This service manual contains technical information, which allow service personnel's to understand and service this model. Please place orders using the parts list and not the drawing reference numbers.

If the circuit is changed or modified, the information will be followed by service manual to be controlled with original service manual.

## 3.2 Important Notice

### 3.2.1 About Lens Block

The image sensor (MOS) Unit which are connected to the lens unit with 3 screws, after performing the Optical tilt adjustment.

During servicing, if one of MOS Unit fixing screws are loosened, the Optical tilt adjustment must be performed. (About the Optical tilt adjustment, refer to the "10.3.2. Adjustment Specifications" for details.)

### 3.2.2 About Venus Engine (IC6001) [Located on the Main P.C.B.]:

The Venus Engine (IC6001) consists of two IC chips (DRAM and Venus) , which are fixed together with solder. (It's called, "Package On Package" type IC.)

When replacing, always replace in pairs. (Units of service parts: integrated (one pair) state.)

#### **NOTE:**

- During servicing, do not press down hard on the surface of IC6001.
- The pad pasted on surface of IC6001, paste on surface of the IC6001 without fail after the replacement.

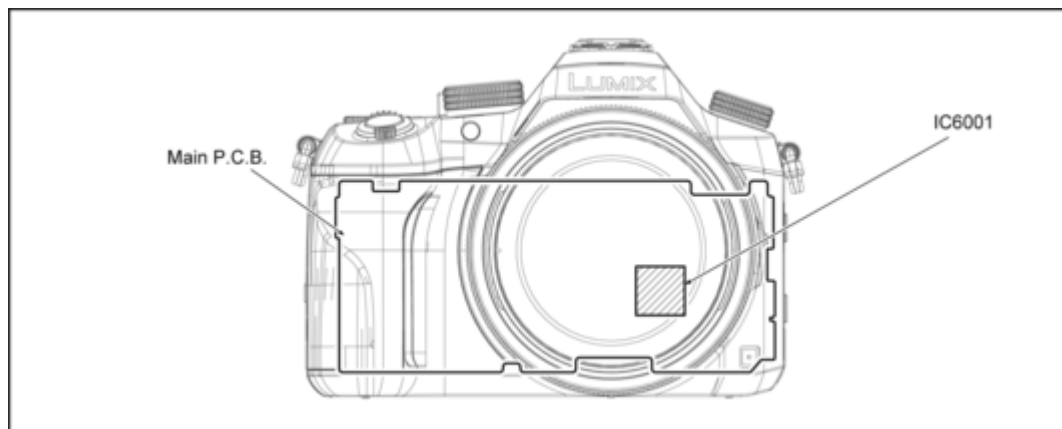

### 3.2.3 About Flexible Cable and Connector

Do not touch carelessly so that the foreign body should not adhere to the terminal part of flexible cable and connector. Wipe off with a clean cloth and the cotton bud, etc. when the terminal part is dirty.

## 3.3 Service Notes

### 3.3.1 About Wi-Fi Function

The page number in this chapter does not show the page number of this service manual.

## What you can do with the Wi-Fi® function

### Controlling with a Smartphone/Tablet (P262)

Recording with a smartphone (P267)

Playing back pictures in the camera (P268)

Saving images stored in the camera (P268)

Sending images in the camera to an SNS (P269)

Writing location information on images stored in the camera (P269)

Combining motion pictures recorded with Snap Movie according to your preference on a smartphone (P271)



### Easy connection

You can easily set up a direct connection to your smartphone without entering a password.



Displaying pictures on a TV (P272)



Printing Wirelessly (P278)



When sending images to AV device (P279)

You can send pictures and motion pictures to AV devices in your house (home AV devices).



When sending images to PC (P280)



Using Web services (P282)

You can send pictures and motion pictures to an SNS, etc. via "LUMIX CLUB".

By using [Cloud Sync. Service], you can receive pictures and motion pictures on a PC or smartphone.

### 3.3.2 Important Notice of Servicing

This camera unit has the personal information of wireless LAN connection the customer has registered.

For the protection of private information, please erase the personal information after the completion of repair by "Initial Settings".

In addition, please print out the following documents, and pass to the customer with the camera unit.

**Printing Material [ Leaflet for Customer ]**



## 3.4 General Description About Lead Free Solder (PbF)

The lead free solder has been used in the mounting process of all electrical components on the printed circuit boards used for this equipment in considering the globally environmental conservation.

The normal solder is the alloy of tin (Sn) and lead (Pb). On the other hand, the lead free solder is the alloy mainly consists of tin (Sn), silver (Ag) and copper (Cu), and the melting point of the lead free solder is higher approx.30°C (86°F) more than that of the normal solder.

**Distinction of P.C.B. Lead Free Solder being used**

The letter of "PbF" is printed either foil side or components side on the P.C.B. using the lead free solder.(See right figure)

PbF

**Service caution for repair work using Lead Free Solder (PbF)**

- The lead free solder has to be used when repairing the equipment for which the lead free solder is used. (Definition: The letter of "PbF" is printed on the P.C.B. using the lead free solder.)
- To put lead free solder, it should be well molten and mixed with the original lead free solder.

- Remove the remaining lead free solder on the P.C.B. cleanly for soldering of the new IC.
- Since the melting point of the lead free solder is higher than that of the normal lead solder, it takes the longer time to melt the lead free solder.
- Use the soldering iron (more than 70W) equipped with the temperature control after setting the temperature at  $350\pm 30^{\circ}\text{C}$  ( $662\pm 86^{\circ}\text{F}$ ).

#### Recommended Lead Free Solder (Service Parts Route.)

- The following 3 types of lead free solder are available through the service parts route.  
SVKZ000001----- (0.3mm 100g Reel)  
SVKZ000002----- (0.6mm 100g Reel)  
SVKZ000003----- (1.0mm 100g Reel)

#### Note

\* Ingredient: Tin (Sn) 96.5%, Silver (Ag) 3.0%, Copper (Cu) 0.5%. (Flux cored)

## 3.5 How to Define the Model Suffix (NTSC or PAL model)

There are seven kinds of DMC-FZH1/FZ2000/FZ2500 regardless of the colours.

- a) DMC-FZH1 (Japan domestic model)
- b) DMC-FZ2500P/PP
- c) DMC-FZ2000EB/EF/EG/EP
- d) DMC-FZ2500GK
- e) DMC-FZ2500GD
- f) DMC-FZ2500GN
- g) DMC-FZ2500GA/GC/GH

What is the difference is that the "Initial Settings" data which is stored in Flash-ROM mounted on Main P.C.B..

### 3.5.1 Defining methods:

To define the model suffix to be serviced, refer to the nameplate which is putted on the bottom side of the unit.

a) **DMC-FZH1 (Japan domestic model)**  
The nameplate for this model shows the following Safety registration mark.



b) **DMC-FZ2500P/PP**  
The nameplate for these models show the following Safety registration mark.



c) **DMC-FZ2000EB/EF/EG/EP**  
The nameplate for these models show the following Safety registration mark.



d) **DMC-FZ2500GK**  
The nameplate for this model shows the following Safety registration mark.



e) **DMC-FZ2500GD**  
The nameplate for this model shows the following Safety registration mark.



f) **DMC-FZ2500GN**  
The nameplate for this model shows the following Safety registration mark.



g) **DMC-FZ2500GA/GC/GH**  
The nameplate for these models do not show any above Safety registration mark.

**NOTE:**

After replacing the Main P.C.B., be sure to achieve adjustment.

**3.5.2 Initial Settings:**

After replacing the Main P.C.B. and/or Flash-ROM, make sure to perform the initial settings after achieving the adjustment by ordering the following procedure in accordance with model suffix of the unit.

**1. Important Notice:**

Before proceeding Initial settings, make sure to read the following CAUTION.

**CAUTION:(Initial Settings)**

---After Replacing the Main P.C.B. and/or Flash-ROM ---  
[Except "EB/EF/EG and EP" models]

\*. The model suffix can be chosen **JUST ONE TIME.**  
(Effective model suffix : "P/PP/GA/GC/GD/GH/GK/GN and JAPAN domestic model")

\*. Once one of the model suffix has been chosen, the model suffix lists will not be displayed, thus, it can not be changed.

**2. Procedures:**

- Precautions: Read the above "CAUTION" carefully.
- Preparation:  
Attach the fully charged Battery, and insert the memory card.  
Remove the lens cap.
- **Step 1. The Temporary Cancellation of "Initial Settings":**  
Set the mode dial to "[ P ] (Program AE mode)", and drive mode dial to "[ Single ]".  
While keep pressing [ AF/AE LOCK ] button and [ DISP. ] button simultaneously, turn the power on.
- **Step 2. The Cancellation of "Initial Settings":**  
Press the [ Playback ] button in order to enter the [ Playback ] mode.

Press [ AF/AE LOCK ] button and “[ UP ] of Cursor buttons” simultaneously, then turn the power off.  
The LCD displays the “ ! ” mark before the unit powers down.

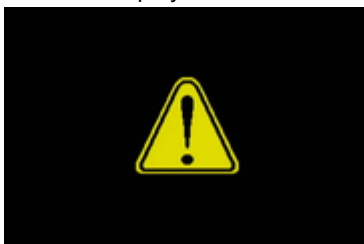

- **Step 3. Turn the Power on:**

Set the mode dial to [ P ] (Program AE Mode), then turn the power on.

- **Step 4. Display the Initial Settings:**

While pressing [ MENU/SET ] button and “[ RIGHT ] of Cursor buttons” simultaneously, turn the power off.  
The “Initial Settings” menu is displayed.

There are two kinds of “Initial Settings” menu form as follows:

[ CASE 1. After replacing the Main P.C.B. and/or Flash-ROM ]

When Main P.C.B. has just been replaced, 14 model suffixes are displayed as follows. (four pages in total)

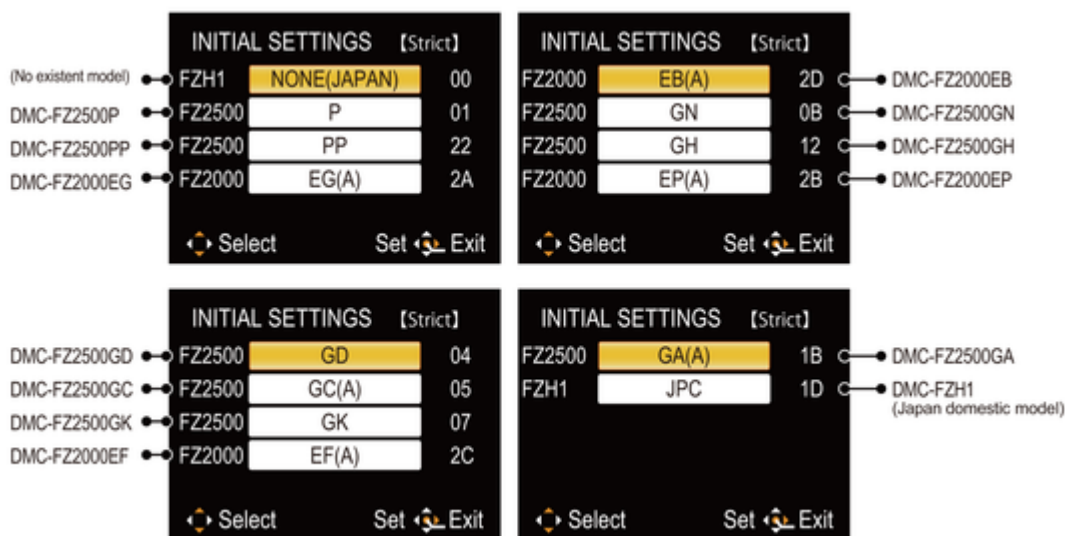

[CASE 2. Other than “After replacing the Main P.C.B. and/or Flash-ROM”]



- **Step 5. Cancel “Strict” mode:**

Press the [ DISP. ] button to cancel “Strict” mode. (Confirm the “Strict” is disappeared.)

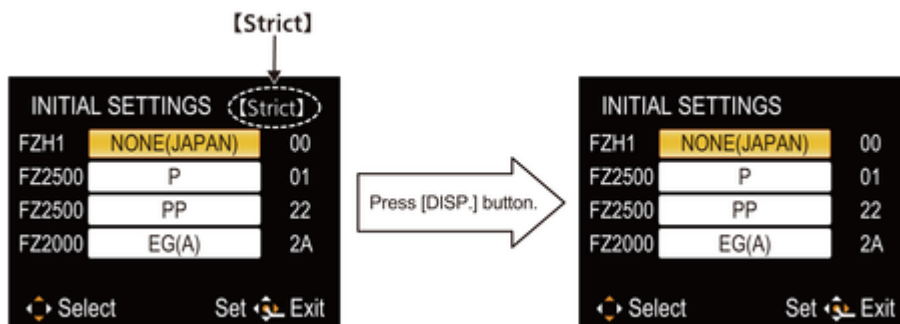

- **Step 6. Choose the Model Suffix in “Initial Settings”: (Refer to “CAUTION”)**

**[Caution: After replacing the Main P.C.B. and/or Flash-ROM]**

The model suffix can be chosen, **JUST ONE TIME** .

Once one of the model suffix have been chosen, the model suffix lists will not be displayed, thus, it can not be changed.

Therefore, select the area carefully.

Select the area with pressing “[ UP ] / [ DOWN ] of Cursor buttons”.

- **Step 7. Set the Model Suffix in “Initial Settings”:**

Press the “[ RIGHT ] of Cursor buttons”.

The only set area is displayed, and then press the “[ RIGHT ] of Cursor buttons” after confirmation.

(The unit is powered off automatically.)

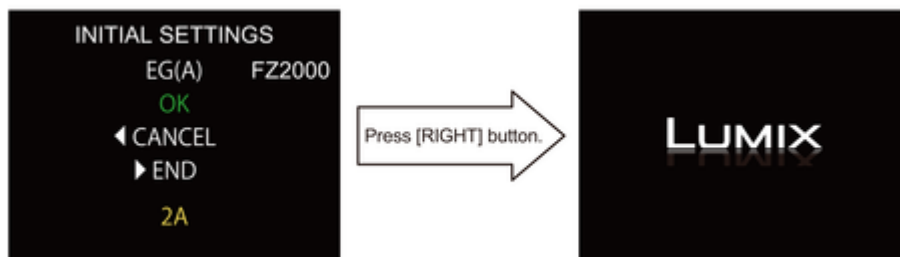

**NOTE:**

When the error message such as the following is displayed, cancel “Strict” mode.

Press [ DISP. ] button to clear the “Strict” display at the upper right corner of screen.

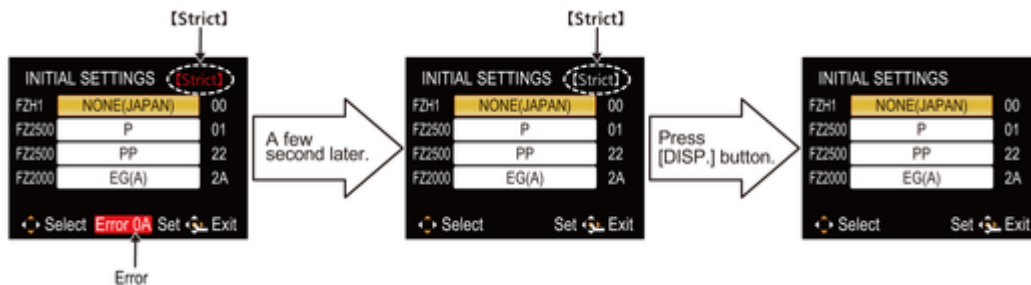

- **Step 8. Confirmation:**

Confirm the display of “PLEASE SET THE CLOCK” in concerned language when the unit is turned on again.

When the unit is connected to PC with USB cable, it is detected as removable media.

(When the “GK” model suffix is selected, the display shows “PLEASE SET THE CLOCK” in Chinese.)

As for your reference, major default setting condition is as shown in the following table.

- **Default setting (After “Initial Settings”)**

	MODEL	VIDEO OUTPUT	LANGUAGE	DATE	REMARKS
a)	DMC-FZ2500P	NTSC	English	Month/Date/Year	

b)	DMC-FZ2500PP	NTSC	English	Month/Date/Year	
c)	DMC-FZ2000EB	PAL	English	Date/Month/Year	
d)	DMC-FZ2000EF	PAL	English	Date/Month/Year	
e)	DMC-FZ2000EG	PAL	English	Date/Month/Year	
f)	DMC-FZ2000EP	PAL	English	Date/Month/Year	
g)	DMC-FZ2500GA	PAL	English	Date/Month/Year	
h)	DMC-FZ2500GC	PAL	English	Date/Month/Year	
i)	DMC-FZ2500GD	NTSC	Korean	Year/Month/Date	
j)	DMC-FZ2500GH	PAL	English	Date/Month/Year	
k)	DMC-FZ2500GK	PAL	Chinese (simplified)	Year/Month/Date	
l)	DMC-FZ2500GN	PAL	English	Date/Month/Year	
m)	DMC-FZH1JPC (Japan domestic model)	NTSC/PAL	NTSC/PAL Japanese/ Chinese (simplified)	Year/Month/Date	

# 4 Specifications

The following specification is for DMC-FZ2000EB.  
Some specifications may differ depending on model suffix.

## Digital Camera:

Information for your safety

<b>Power Source:</b>	DC 8.4 V (≈8.4 V)	
<b>Power Consumption:</b>	2.5 W (When recording with Monitor) 3.1 W (When recording with Viewfinder) 1.6 W (When playing back with Monitor) 1.7 W (When playing back with Viewfinder)	
<b>Camera effective pixels</b>	20,100,000 pixels	
<b>Image sensor</b>	1" MOS sensor, total pixel number 20,900,000 pixels, Primary colour filter	
<b>Lens</b>	Optical 20× zoom, f = 8.8 mm to 176 mm (35 mm film camera equivalent: 24 mm to 480 mm) Wide: F2.8 to F11 Tele: F4.5 to F11	
<b>ND filter</b>	[AUTO]/[1/4]/[1/16]/[1/64]/[OFF]	
<b>Image Stabiliser</b>	Optical method	
<b>Focus range</b>		
AF	30 cm (0.98 feet) (Wide)/1 m (3.3 feet) (Tele) to ∞	
AF Macro/MF/ Intelligent Auto/ Motion Picture	3 cm (0.098 feet) (Wide)/1 m (3.3 feet) (Tele) to ∞	
<b>Shutter system</b>	Electronic shutter+Mechanical shutter	
<b>Minimum illumination</b>	Approx. 9 lx [when i-Low light is used, the shutter speed is 1/30th of a second (When [System Frequency] is set to [59.94 Hz (NTSC)]) or 1/25th (When [System Frequency] is set to [50.00 Hz (PAL)])]	
<b>Shutter speed</b>		
Still picture	B (Bulb) (Max. approx. 120 second), 60 to 1/4000th seconds (with the mechanical shutter) 1 to 1/16000th seconds (with the electronic shutter)	
Motion picture	1/30th of a second to 1/16000th of a second (When [System Frequency] is set to [59.94 Hz (NTSC)])/ 1/25th of a second to 1/16000th of a second (When [System Frequency] is set to [50.00 Hz (PAL)])/ 1/24th of a second to 1/16000th of a second (When [System Frequency] is set to [24.00 Hz (CINEMA)]) 1/2th of a second to 1/16000th of a second (When [M] is selected in Creative Video Mode, MF)	
<b>Exposure (AE)</b>	Programme AE (P)/Aperture-Priority AE (A)/ Shutter-Priority AE (S)/Manual Exposure (M)/AUTO	
<b>Light metering mode</b>	Multiple/Centre weighted/Spot	
<b>Monitor</b>	3.0" TFT LCD (3:2) (Approx. 1,040,000 dots) (field of view ratio about 100%) Touch screen	
<b>Viewfinder</b>	OLED Live Viewfinder (4:3) (Approx. 2,360,000 dots) (field of view ratio about 100%) (with diopter adjustment -4 to +4 diopter)	
<b>Flash</b>	Built-in pop up flash AUTO, AUTO/Red-Eye Reduction, Forced ON, Forced ON/ Red-Eye Reduction, Slow Sync., Slow Sync./Red-Eye Reduction, Forced OFF	
<b>Microphone</b>	Stereo	
<b>Speaker</b>	Monaural	
<b>Recording media</b>	SD Memory Card/SDHC Memory Card <sup>®</sup> /SDXC Memory Card <sup>®</sup> (= UHS-I UHS Speed Class 3)	
<b>Recording file format</b>		
Still Picture	RAW/JPEG (based on "Design rule for Camera File system", based on "Exif 2.3" standard, DPOF corresponding)	
<b>Motion pictures</b>	AVCHD Progressive/AVCHD/MP4/MOV	
<b>Audio compression</b>	AVCHD MP4 MP4 (LPCM), MOV	Dolby <sup>®</sup> Digital (2 ch) AAC (2 ch) LPCM (2 ch)



<b>Interface</b>	
<b>Digital</b>	*USB 2.0* (High Speed) * Data from the PC can not be written to the camera using the USB connection cable.
<b>Terminal</b>	
<b>[REMOTE]</b>	∅ 2.5 mm jack
<b>[MIC]</b>	∅ 3.5 mm jack
<b>Headphone</b>	∅ 3.5 mm jack
<b>[HDMI]</b>	MicroHDMI Type D
<b>USB</b>	USB 2.0 Micro-B
<b>Dimensions</b>	Approx. 137.6 mm (W)×101.9 mm (H)×134.7 mm (D) [5.42"(W)×4.01"(H)×5.30"(D)]
<b>Mass</b>	Approx. 966 g/2.13 lb (with card and battery) Approx. 915 g/2.02 lb (excluding card and battery)
<b>Operating temperature</b>	0 °C to 40 °C (32 °F to 104 °F)
<b>Operating humidity</b>	10%RH to 80%RH
<b>Wireless transmitter</b>	
<b>Compliance standard</b>	IEEE 802.11b/g/n (standard wireless LAN protocol)
<b>Frequency range used (central frequency)</b>	2412 MHz to 2462 MHz (1 to 11ch)
<b>Encryption method</b>	Wi-Fi compliant WPA™/WPA2™
<b>Access method</b>	Infrastructure mode

**Battery Charger (Panasonic DE-A80A):**

Information for your safety

<b>Input:</b>	AC ~ 110 V~240 V 50/60 Hz 0.2 A
<b>Output:</b>	DC = 8.4 V 0.65 A

**Battery Pack (lithium-ion) (Panasonic DMW-BLC12E):**

Information for your safety

<b>Voltage/capacity:</b>	7.2 V/1200 mAh
--------------------------	----------------

The symbols on this product (including the accessories) represent the following:

~	AC
=	DC
□	Class II equipment (The construction of the product is double-insulated.)

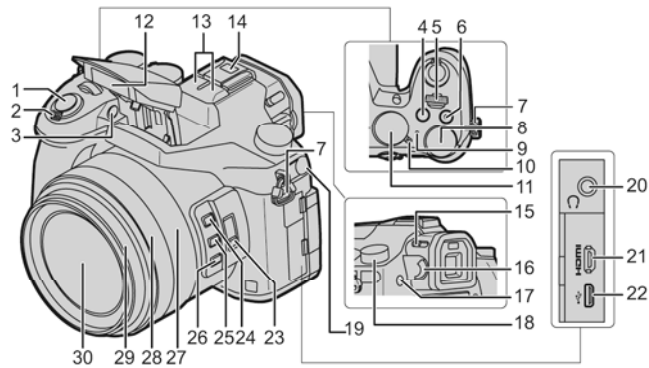

<b>1</b>	Shutter button (P18)	<b>18</b>	Drive mode dial (P27)
<b>2</b>	Zoom lever (P18)	<b>19</b>	[MIC] socket
<b>3</b>	Self-timer indicator/ AF Assist Lamp		Headphone socket
<b>4</b>	[  ] (Exposure Compensation) button/ [Fn4] button (P23)	<b>20</b>	• Excessive sound pressure from earphones and headphones can cause hearing loss.
<b>5</b>	Front dial (P20)	<b>21</b>	[HDMI] socket
<b>6</b>	Motion picture button (P36)	<b>22</b>	USB socket
<b>7</b>	Shoulder strap eyelet (P13)	<b>23</b>	[ND FILTER] switch (P21)
<b>8</b>	Rear dial (P20)	<b>24</b>	[Fn1] button (P23)
<b>9</b>	Status indicator (P16)/ Wi-Fi <sup>®</sup> connection lamp (P52)	<b>25</b>	[Fn2] button (P23)
<b>10</b>	Camera ON/OFF switch (P16)	<b>26</b>	[Fn3] button (P23)
<b>11</b>	Mode dial (P19)	<b>27</b>	Zoom ring (P18)
<b>12</b>	Flash	<b>28</b>	Focus ring (P26)
<b>13</b>	Stereo microphone • Be careful not to cover the microphone with your finger. Doing so may make sound difficult to record.	<b>29</b>	Lens barrel
<b>14</b>	Hot shoe (Hot shoe cover) • Keep the Hot Shoe Cover out of reach of children to prevent swallowing.	<b>30</b>	Lens surface
<b>15</b>	Flash open lever • The flash opens, and recording with the flash becomes possible.		
<b>16</b>	Diopter adjustment dial (P18)		
<b>17</b>	[LVF] button (P17)/[Fn7] button (P23)		

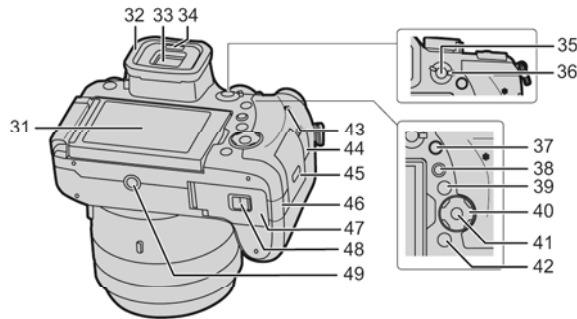

31	Touch screen (P21)/monitor (P58)
32	Eyecup
33	Viewfinder (P17)
34	Eye sensor (P17)
35	[AF/AE LOCK] button
36	Focus mode lever
37	[Q.MENU] button (P23)/[Fn5] button (P23)
38	[▶] (Playback) button (P45)
39	[DISP.] button • Each time this is pressed, the display on the monitor is switched.
40	Cursor buttons (P19) ▲/[ISO] (ISO sensitivity) ▶/[WB] (White Balance) ◀/[AF-ON] (Auto Focus Mode) ▼/[AF-ON] (AF Macro) (P27)
41	[MENU/SET] button (P19)
42	[⏏/⏏] (Delete/Cancel) button (P46)/[Fn6] button (P23)
43	Speaker
44	[REMOTE] socket
45	Card door (P15)

46	DC coupler cover (P69) • When using an AC adaptor, ensure that the Panasonic DC coupler (DMW-DCC8: optional) and AC adaptor (DMW-AC10E: optional) are used. • Always use a genuine Panasonic AC adaptor (DMW-AC10E: optional). • When using an AC adaptor, use the AC mains Lead supplied with the AC adaptor.
47	Battery door (P14)
48	Release lever (P14)
49	Tripod mount • It may not be possible to attach and securely fasten a tripod with a screw length of 5.5 mm (0.22 inch) or more to the camera. Doing so may also damage the camera.

■ **About the function button ([Fn8] to [Fn12])**  
• Function buttons ([Fn8] to [Fn12]) (P23) are touch icons. Touch the [Fn] tab on the recording screen to display them.

■ **Removing the Hot Shoe Cover**  
The camera comes with a hot shoe cover attached to the hot shoe.

Remove the hot shoe cover by pulling it in the direction indicated by arrow ② while pressing it in the direction indicated by arrow ①.

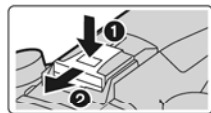

## 6 Service Mode

### 6.1 Error Code Memory Function

#### 1. General description

This unit is equipped with history of error code memory function, and can be memorized 16 error codes in sequence from the latest. When the error is occurred more than 16, the oldest error is overwritten in sequence.

The error code is not memorized when the power supply is shut down forcibly (i.e., when the unit is powered on by the battery, the battery is pulled out) The error code is memorized to Flash-ROM when the unit has just before powered off.

#### 2. How to display

The error code can be displayed by ordering the following procedure:

##### o Preparation

Attach the fully charged Battery, and insert the memory card.  
Remove the lens cap.

##### o Step 1. The Temporary Cancellation of "Initial Settings":

Set the mode dial to "[ P ] (Program AE mode)", and drive mode dial to "[ Single ]".  
While keep pressing [ AF/AE LOCK ] button and [ DISP. ] button simultaneously, turn the power on.

##### o Step 2. Execute the Error Code Display Mode:

While keep pressing [ AF/AE LOCK ] button, [ MENU/SET ] button and "[ LEFT ] of Cursor buttons" simultaneously.

The display is changed as shown below when the above buttons are pressed simultaneously.

Normal display → Error code display → Camera information display → Normal display → .....

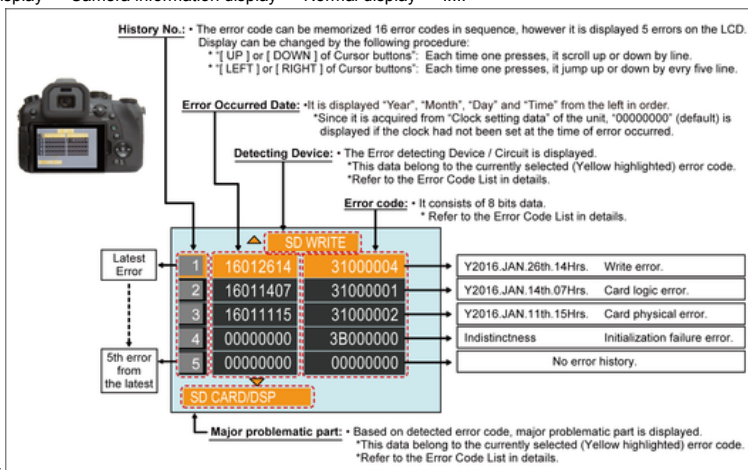

Example of Error Code Display

##### o Error Code List

The error code consists of 8 bits data and it shows the following information.

Attribute	Main item	Sub item	Error code		Contents	Error Indication						
			High 4 bits	Low 4 bits		Detecting device	Problematic Part/Circuit					
LENS	Lens drive	OIS	1C*0	1000	OIS Position sensor (X) error	OIS POS X	LENSu/LENS FPC					
				2000	OIS Position sensor (Y) error	OIS POS Y						
				3000	OIS GYRO sensor (X) error	OIS GYRO X	GYRO					
				4000	OIS GYRO sensor (Y) error	OIS GYRO Y						
				5000	OIS GYRO sensor (R) error	OIS GYRO R	LENSu/LENS FPC					
				6000	OIS drive voltage (X) error	OIS DRIVE X						
				7000	OIS drive voltage (Y) error	OIS DRIVE Y						
				8000	OIS GYRO-Digital communication error	OIS GYRO COMM	GYRO					
		Zoom				0710	Collapsible barrel Low detect error	ZOOM L	ZOOMm/LENSu			
						0720	Collapsible barrel High detect error	ZOOM H				
						0730	Collapsible barrel encoder detect error (Initialization or termination)	ZOOM ENC				
						0740	Collapsible barrel encoder detect error (During monitor mode.)					
						0750	Collapsible barrel encoder detect error (During monitor mode with slow speed.)					
		0760	Zoom step-out detect error	ZOOM STEP-OUT								
		Focus				0701	Focus encoder Low detect error	FOCUS L	LENS FPC/DSP			
						0702	Focus encoder High detect error	FOCUS H				
						0703	Focus MR sensor phase A output voltage error	FOCUS MRA				
						0704	Focus MR sensor phase B output voltage error	FOCUS MRB				
						0705	Focus lock error	FOCUS LOCK				
						0706	Focus MR sensor phase A comparator signal error	FOCUS CMPA				
						0707	Focus MR sensor phase B comparator signal error	FOCUS CMPB				
						0708	Focus reference voltage error	FOCUS REF				
		Lens				18*1	0000	Lens Power On timeout error	LENS DRV	LENSu		
						18*2	0000	Lens Power Off timeout error				
		Zoom				38*0	0001	Zoom operation timeout error	ZOOM	ZOOMm/LENSu		
		Adj. History	OIS		1D*0	2000	OIS adj. Yaw direction amplitude error (small)	OIS ADJ	OIS ADJ			
						3000	OIS adj. Pitch direction amplitude error (small)					
						4000	OIS adj. Yaw direction amplitude error (large)					
						5000	OIS adj. Pitch direction amplitude error (large)					
						8000	OIS adj. Yaw direction off set error					
						9000	OIS adj. Pitch direction off set error					
						A000	OIS adj. Yaw direction gain error					
B000	OIS adj. Pitch direction gain error											
C000	OIS adj. Yaw direction position sensor error											
D000	OIS adj. Pitch direction position sensor error											
E000	OIS adj. other error											
HARD	Flash					Flash	28*0			0000	Flash charge timeout error (system error indicated)	STRB CHG
		0001	EEPROM of External Flash is damaged.	EST EEP	E. STRB							
		0002	ZOOM function of External Flash is damaged.	EST								
	BIS	In Body Image Stabilization		28*0	0003	Other function of External Flash is damaged.	EST	BIS				
					0010	BIS HP encoder (X) Low detect error	BIS HPL X					
					0020	BIS HP encoder (X) High detect error	BIS HPH X					
					0030	BIS HP encoder (Y) Low detect error	BIS HPL Y					
					0040	BIS HP encoder (Y) High detect error	BIS HPH Y					
					0050	BIS GYRO (X) error	BIS GYRO X					
					0060	BIS GYRO (Y) error	BIS GYRO Y					
					0070	BIS GYRO communication error	BIS GY DIF					
					0080	BIS GYRO (R) error	BIS GYRO R					
					0090	BIS APU timeout error	BIS APU					
					0100	BIS Position sensor (X1) error	BIS POS X1					
					0200	BIS Position sensor (X2) error	BIS POS X2					
					0300	BIS Position sensor (Y) error	BIS POS Y					
					0400	BIS Drive Voltage (X1) error	BIS DRIVE X1					
					0500	BIS Drive Voltage (X2) error	BIS DRIVE X2					
					0600	BIS Drive Voltage (Y) error	BIS DRIVE Y					
					0700	BIS DIFF Signal (X1) error	BIS DIFF X1					
	0800	BIS DIFF Signal (X2) error	BIS DIFF X2									
	0900	BIS DIFF Signal (Y) error	BIS DIFF Y									
	Flash-ROM	Data Area		2B*0	0001	EEPROM data error (During read out)	FROM RE	FROM				
					0002	EEPROM data error (During write in)	FROM WR					
		Program Area				0005	Firmware update error	FIRMUP FAIL	USB			
						0006	Firmware update error (USB Micon)	USBFWUP FAIL				

Attribute	Main item	Sub item	Error code		Contents	Error Indication		
			High 4 bits	Low 4 bits		Detecting device	Problematic Part/Circuit	
SOFT	CPU	Reset	30*0	0000	System error (NMI reset)	NMI RST	MAIN PCB	
	Recording Media	Memory card	31*0	0002	Memory card physical error	SD CARD	SD CARD/DSP	
				0004	Memory card writing error	SD WRITE		
	Lens	Communication	3C11   3CF0	****	Lens communication error	LENS COMM	SOFT	
	Camera	System	37*0	0001	Activation: Electronic signature hash value mismatch	VLOG	VLOG	
				0002	Activation: Serial number mismatch			
				0003	Activation: Model name mismatch			
				0004	Activation: Origin country mismatch			
				0005	Activation: Firmware version down			
				0006	Activation: Activation code mismatch			
				0007	Activation: Old firmware			
				3B*0	0000	EEPROM writing during camera initialization	FROM	SOFT
				3D*0	0000	Assert occurrence	ASSERT	SOFT
				3E*0	0001	Exposure charging operation failure	MSHUT	MSHUT
					0002	Failure of the returning operation to the home position		
					0003	Failure of the mecha shutter sensor		
					0004	Failure of the mecha shutter sensor		
0005	Failure of the mecha shutter sensor							
0006	Exposure charging recovery operation failure							
0011	Failure of the mecha shutter sensor							
0012	Failure of the mecha shutter sensor							
0013	Failure of the mecha shutter sensor							
0014	Abnormal current of shutter drive motor							
0101	Failure of the electromagnetic front curtain open							
0102	Failure of the electromagnetic front curtain open							
0111	Failure of the electromagnetic front curtain open							
0112	Failure of the electromagnetic front curtain open							
Recording	Motion Image Recording	3F*0	0001	File time out error in recording motion image	MOVR T.O.	SOFT		
			0002	File data cue send error in recording motion image	MOVR FILE	MOVR T.O.		
Wi-Fi			3211	****	Wi-Fi related errors: *Generally, above are unable to specified the, which cannot be used for malfunction diagnosis.	WiFi	WiFi	

#### Important notice about "Error Code List"

##### 1) About "\*" indication:

The third digit from the left is different as follows.

- In case of 0 (example: 18 001000)  
When the third digit from the left shows "0", this error occurred under the condition of Initial Settings has been completed.  
It means that this error is occurred basically at user side.
- In case of 8 (example: 18 801000)  
When the third digit from the left shows "8", this error occurred under the condition of Initial Settings has been released.  
(Example; Factory assembling-line before unit shipment, Service mode etc.)  
It means that this error is occurred at service side.

##### 2) About "?" indication: ("18\*0 0?01" to "18\*0 0?60"):

The third digit from the right shows one of the hexadecimal ("0" to "F") character.

##### ○ Step 3. How to exit from Error Code display mode:

Simply, turn the power off. (Since Error code display mode is executed under the condition of temporary cancellation of "Initial Settings", it wake up with normal condition when turn off the power.)

##### NOTE:

The error code can not be initialized.

# 7 Troubleshooting Guide

## 7.1 Wi-Fi Module (Flash P.C.B. Unit)

### 7.1.1 How to Remove Wi-Fi Password Protection

To prevent incorrect operation or use of the Wi-Fi function by a third party and to protect saved personal information, this unit protects the Wi-Fi function with a password.

It is unable to service with password locked condition. When accepting for repair, the unit has been set the Wi-Fi password by customer, run the [ Reset Wi-Fi Settings ] for removing Wi-Fi password, then check the operation.

#### **[Reset Procedure of Wi-Fi Settings]**

- 1) Press the [ MENU/SET ] button, and select the [ SETUP ] mode by Cursor buttons. Select [ Reset Wi-Fi Settings ] by Cursor buttons, then press the [ MENU/SET ] button.
- 2) Select [ YES ] and press the [ MENU/SET ] button.

(The [ Reset Wi-Fi Settings ] performs not only resetting Wi-Fi Password but also resetting other all Wi-Fi Settings.)

### 7.1.2 Checking of Trouble Caused by Wi-Fi Module or Not

The Wi-Fi Circuit works properly if the wireless access point (broadband router) name (SSID) in use is displayed on a screen of [ Manual Connection ].

#### **(Primary Confirmation)**

Confirm that the wireless access point (broadband router) works properly.

#### **(Procedure)**

- 1) Select [ Wi-Fi ] in [ Setup ] menu.
- 2) Select [ Wi-Fi Function ] in [ Wi-Fi ] menu.
- 3) Select [ New Connection ] in [ Wi-Fi ] menu.
- 4) Select optional function in [ Select a function ] menu, then select [ Via Network ] in [ Select connection method ] menu.
- 5) Select [ From List ] in [ Select connection method ] menu.
- 6) The Wi-Fi Circuit works properly if the wireless access point (broadband router) name (SSID) in use is displayed.









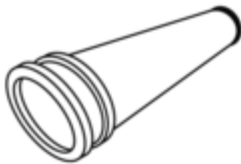
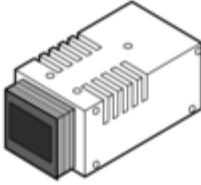
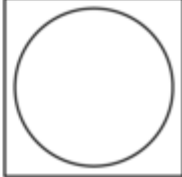

\*Change the Flash P.C.B. Unit, when the above checking detected the abnormal of Wi-Fi module.

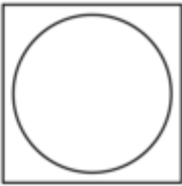
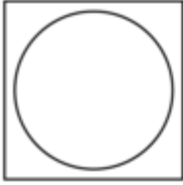
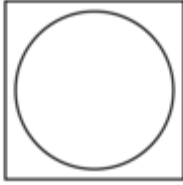
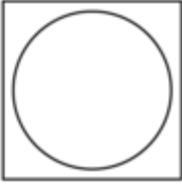
# 8 Service Fixture & Tools

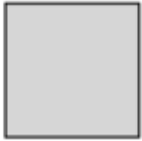
## 8.1 Service Fixture and Tools

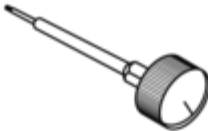
The following Service Fixture and tools are used for checking and servicing this unit.



Collimator (built-in Focus Chart) RFKZ0422	Light Box (with DC Cable) RFKZ0523	ND Filter (ND0.3) RFKZ0513
		
ND Filter (ND0.6) VFK1164ND06	ND Filter (ND 0.9) VFK1164ND09	CC Filter (CC-C7.5) RFKZ0511
		
CC Filter (CC-Y10) RFKZ0512	LB Filter (LBB2) RFKZ0520	LB Filter (LBB8) RFKZ0521
		
Gray Card RFKZ0506	Gray Chart RFKZ0612	Resistor for Discharging (1kΩ/5W) ERG5SJ102
		 * An equivalent type of resistor may be used.
Lens Cleaning Kit (BK) VFK1900BK	Driver (for Optical Tilt Adjustment) RFKZ0569	Optical Tilt Adjustment Chart RFKZ0570
 * Only supplied 10 set/box.	 * T4 Torx type	
Camera Stand RFKZ0333J	Torque Driver RFKZ0542	Grease (for Lens) RFKZ0472
		

## 8.2 When Replacing the Main P.C.B.

After replacing the Main P.C.B., be sure to achieve adjustment.

## 8.3 Service Position

This Service Position is used for checking and replacing parts. Use the following Extension cables for servicing.

Table S1 Extension Cable List

No.	Parts No.	Connection	Form
1	VFK1440	FP9008 (MAIN P.C.B.) ↔ DIAL ZOOM UNIT (TOP CASE UNIT)	10pin / 0.5 FFC
2	VFK1175	FP9002 (MAIN P.C.B.) ↔ TOP OPERATION UNIT (TOP CASE UNIT)	16pin / 0.5 FFC
3	VFK1492	FP9006 (MAIN P.C.B.) ↔ MULTI FPC UNIT	26pin / 0.5 FFC
4	VFK1950	FP7901 (MAIN P.C.B.) ↔ LENS UNIT	33pin / 0.3 FFC
5	RFKZ0477	FP7902 (MAIN P.C.B.) ↔ LENS UNIT	45pin / 0.3 FFC
6	VFK1175	FP9007 (MAIN P.C.B.) ↔ REAR OPERATION FPC (REAR CASE UNIT)	16pin / 0.5 FFC
7	RFKZ0477	FP9003 (MAIN P.C.B.) ↔ LCD UNIT	45pin / 0.3 FFC
8	VFK1870	PS9001 (MAIN P.C.B.) ↔ PP8001 (FLASH P.C.B. UNIT)	30pin B to B

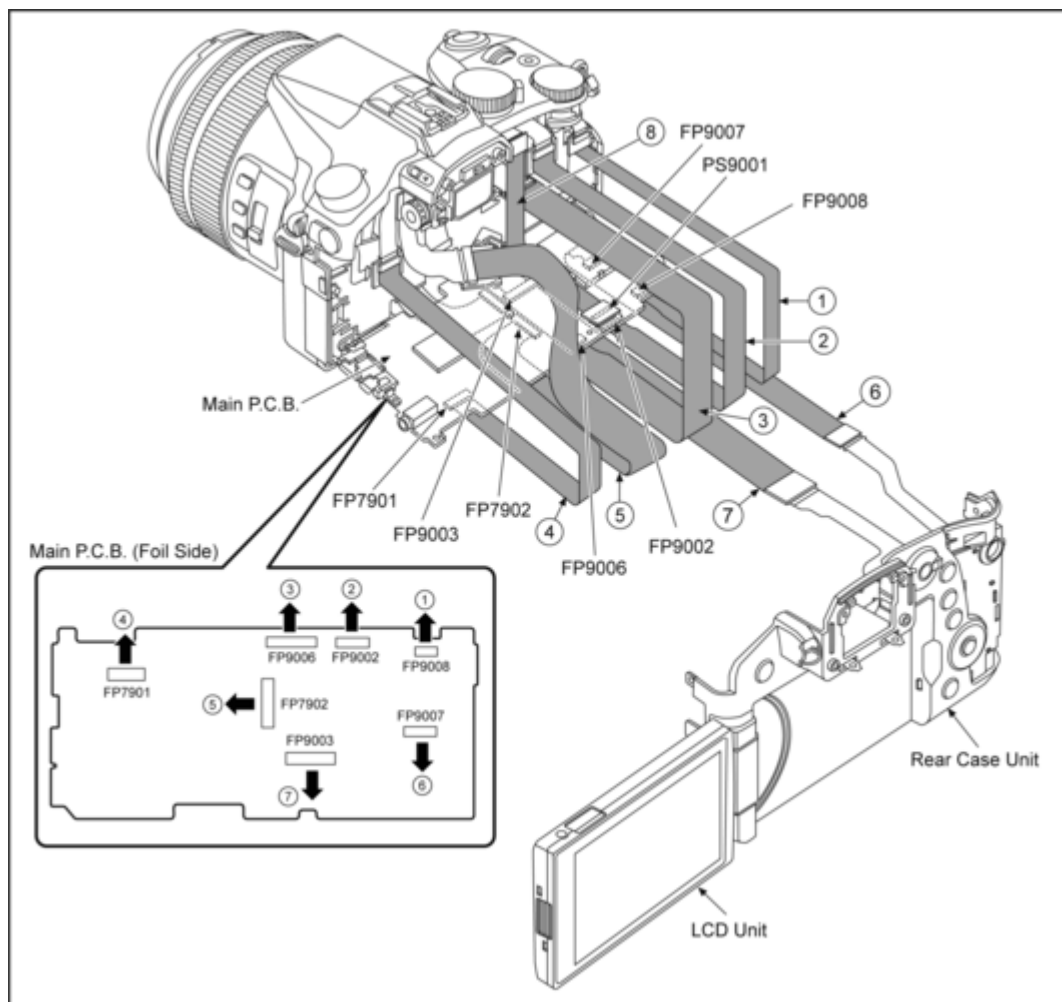

### CAUTION. (When servicing Flash P.C.B. Unit)

1. Be sure to discharge the E.Capacitor on Flash P.C.B. Unit.  
Refer to "How to Discharge the E.Capacitor on Flash P.C.B. Unit".  
The E.Capacitor voltage is not lowered soon even if the AC Cord is unplugged or the battery is removed.
2. Be careful of the high voltage circuit on Flash P.C.B. Unit.
3. DO NOT allow other parts to touch the high voltage circuit on Flash P.C.B. Unit.

# 9 Disassembly and Assembly Instructions

## 9.1 Disassembly Flow Chart

This is a disassembling chart.

When assembling, perform this chart conversely.

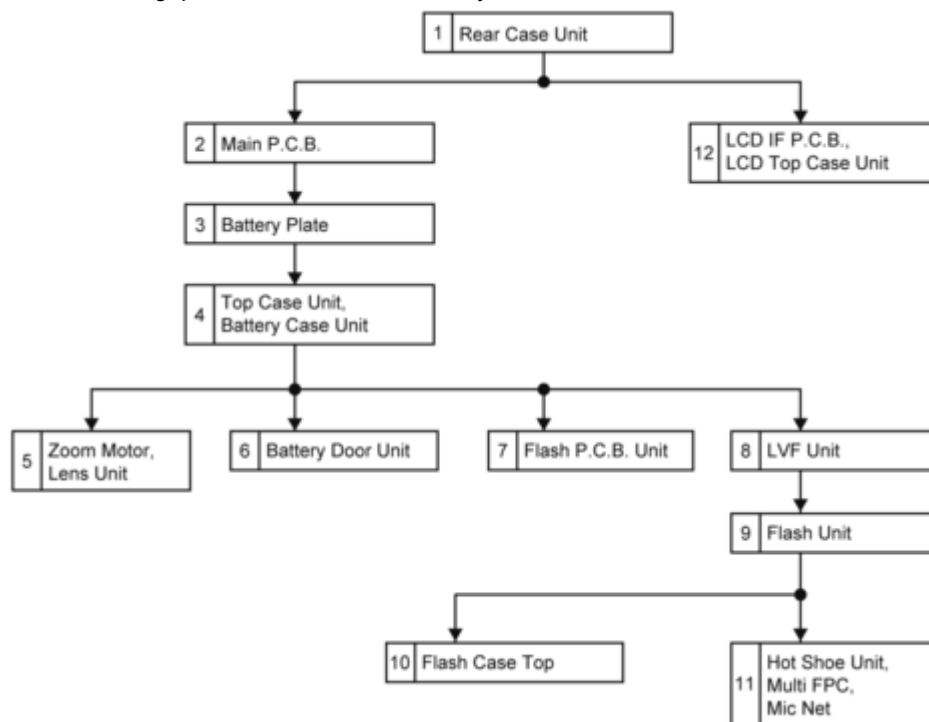

## 9.2 P.C.B. Location

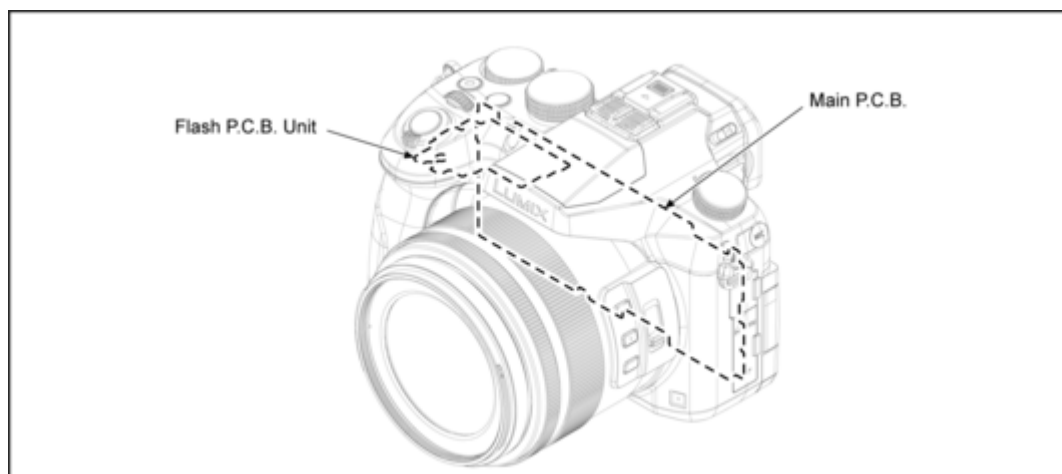

## 9.3 Disassembly Procedure

No.	Item	Fig.	Removal			
1	Rear Case Unit	(Fig. D1)	Screw (A) x 3			
			Screw (B) x 1			
			Screw (C) x 2			
		(Fig. D2)	Locking tab x 2			
			Eye Cup Unit			
			Screw (D) x 2			
			Screw (E) x 2			
		(Fig. D3)	Screw (F) x 1			
			Locking tab x 3			
			Rear Grip			
		(Fig. D4)	Screw (G) x 3			
			FP9003 (Flex)			
			FP9007 (Flex)			
			Rear Case Unit			
2	Main P.C.B.	(Fig. D5)	FP7901 (Flex)			
			FP7902 (Flex)			
			FP9001 (Flex)			
			FP9002 (Flex)			
			FP9006 (Flex)			
			FP9008 (Flex)			
			FP9009 (Flex)			
			P9004(Connector)			
			Screw (H) x 4			
			Screw (I) x 1			
			Screw (J) x 1			
			Remote Cover Unit			
			Locking tab x 1			
			PS9001(Connector)			
			Main P.C.B.			
			3	Battery Plate	(Fig. D6)	Locking tab x 2
						Convex x 3
Battery Plate						
4	Top Case Unit, Battery Case Unit	(Fig. D7)	Screw (K) x 1			
			Locking tab x 3			
			Front Grip			
			Screw (L) x 1			
			Screw (M) x 1			
		(Fig. D8)	Screw (N) x 2			
			Screw (O) x 2			
			Screw (P) x 2			
		(Fig. D9)	Locking tab x 2			
			Top Case Unit Battery Case Unit			
(Fig. D10)	NOTE: (When Installing)					
5	Zoom Motor, Lens Unit	(Fig. D11)	Screw (Q) x 1			
			Convex x 2			
			Jack Holder Unit			
			Connector x 1			
			Screw (R) x 2			
			Convex x 2			

			Zoom Motor
			Screw (S) x 5
		(Fig. D12)	Convex x 4
			Lens Top Plate
			Lens Plate
			Lens Unit
6	Battery Door Unit	(Fig. D13)	Battery Door Shaft
			Battery Door Spring
			Battery Door Unit
7	Flash P.C.B. Unit	(Fig. D14)	Convex x 1
			Antenna FPC
			Locking tab x 1
			Screw (T) x 1
			Locking tab x 4
			Capacitor Cover
		(Fig. D15)	CAUTION
		(Fig. D16)	Locking tab x 2
			Convex x 2
			Flash P.C.B. Unit
8	LVF Unit	(Fig. D17)	Screw (U) x 1
			LVF Unit
9	Flash Unit	(Fig. D18)	Screw (V) x 1
			Flash Earth Plate
		(Fig. D19)	Connector x 1
			Convex x 2
			Locking tab x 2
			Flash Lock Knob
			Convex x 2
			Screw (W) x 4
			Locking tab x 1
			Hooking part x 1
			Flash Unit
10	Flash Case Top	(Fig. D20)	Screw (X) x 3
			Locking tab x 2
			Flash Case Top
11	Hot Shoe Unit, Multi FPC, Mic Net	(Fig. D21)	Shoe Spring
			Screw (Y) x 4
			Solder (5 points)
			Multi FPC
			Hot Shoe Unit
		(Fig. D22)	Mic Net
			Mic Net B
			Mic Cushion Top
12	LCD IF P.C.B., LCD Top Case Unit	(Fig. D23)	Screw (Z) x 1
			Screw (a) x 1
		(Fig. D24)	Screw (b) x 1
			Screw (c) x 1
			Locking tab x 8
			LCD Case Bottom
		(Fig. D25)	FP7201 (Flex)
			FPC Tape
			FP7202 (Flex)
			FP7203 (Flex)
			FP7204 (Flex)
			Hooking part x 4

	(Fig. D26)	LCD IF P.C.B.
		LCD Bezel Sheet
		Convex x 2
		MR SW FPC
		LCD Bezel
		LCD Top Case Unit

**NOTE:**

- When servicing and reassembling, remove the memory card and battery from the unit.
- Install the lens cap to prevent garbage and dust except when it is necessary.
- Do not reuse screws tightened to metal parts. Be sure to use new screws when assembling.

- Memory Card
- Battery

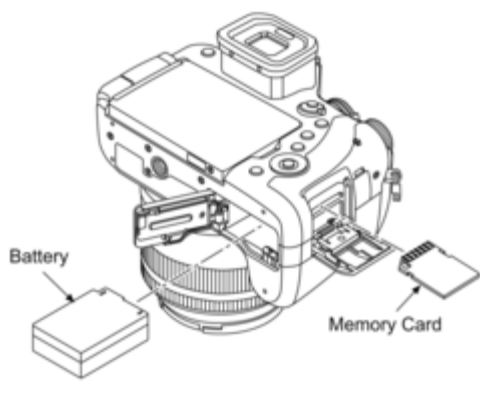

### 9.3.1 Removal of the Rear Case Unit

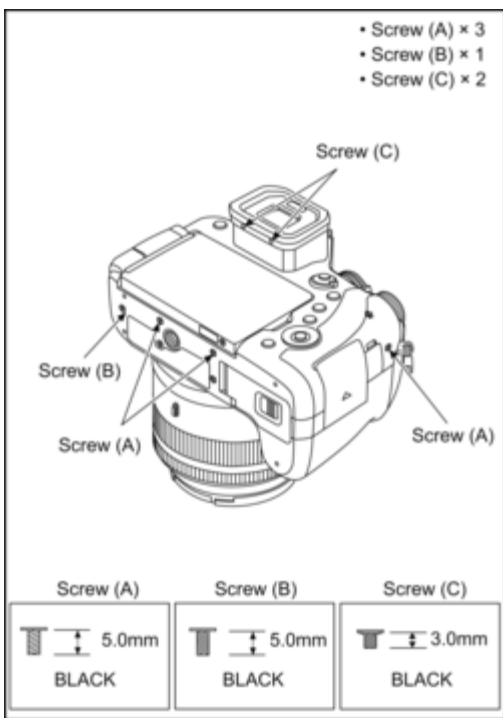

(Fig. D1)

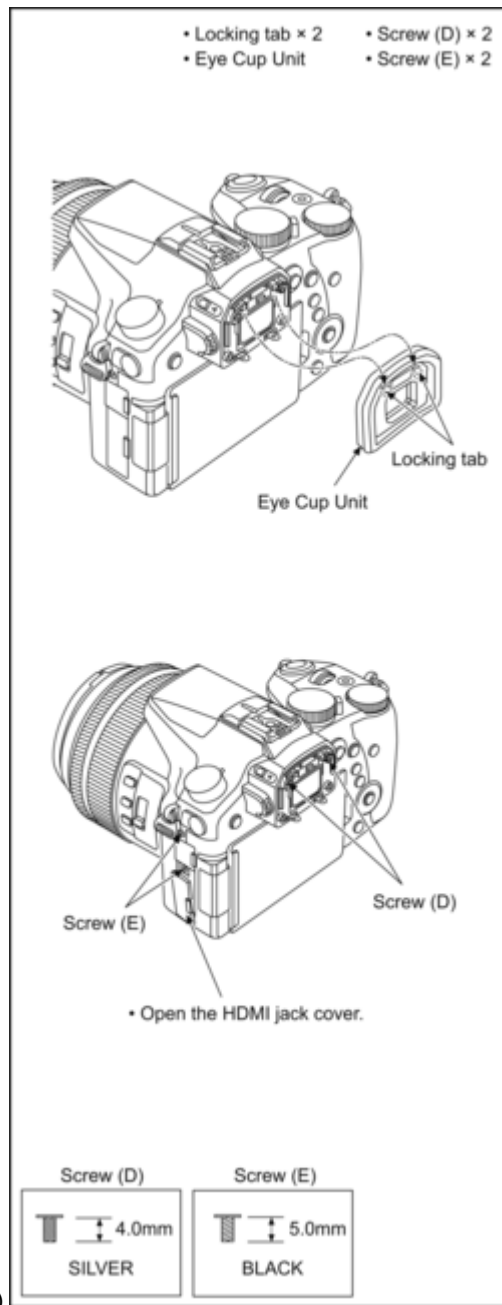

(Fig. D2)

(Fig. D3)

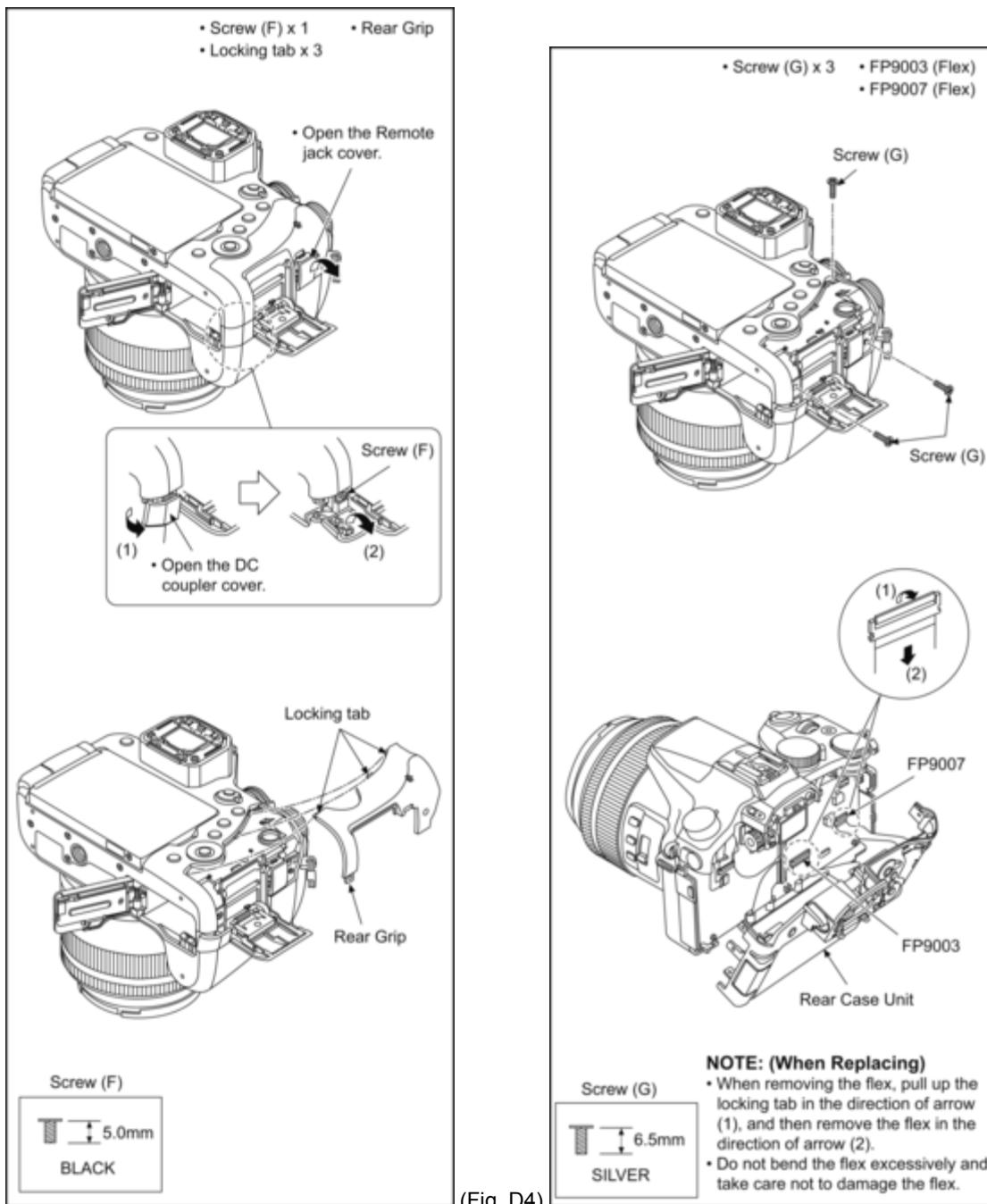

(Fig. D4)

### 9.3.2 Removal of the Main P.C.B.



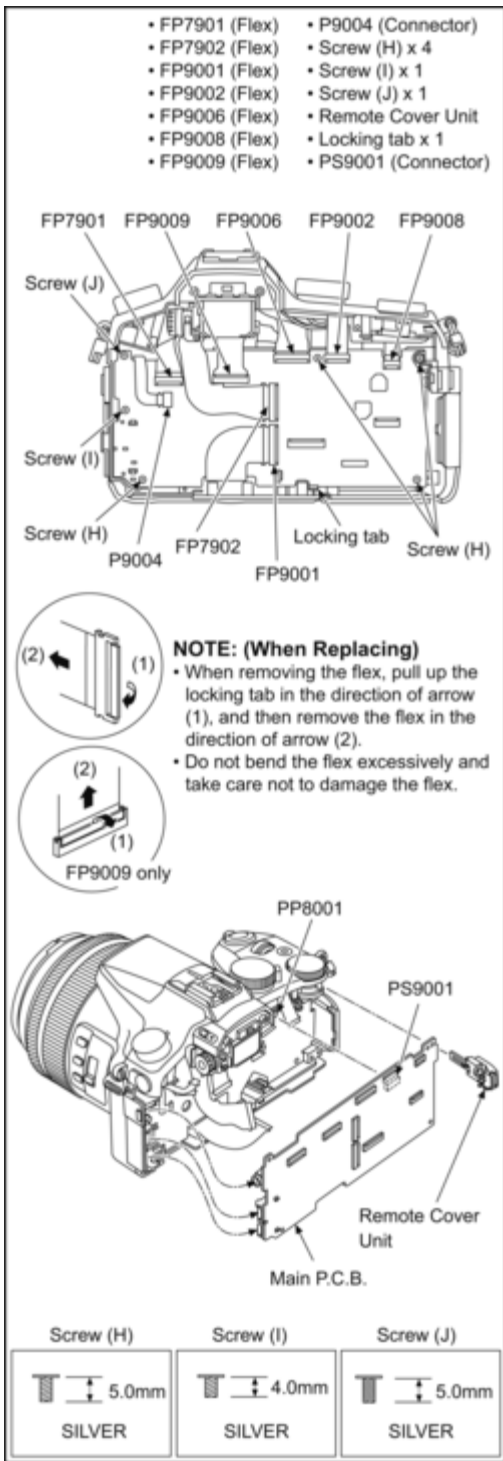

(Fig. D5)

### 9.3.3 Removal of the Battery Plate

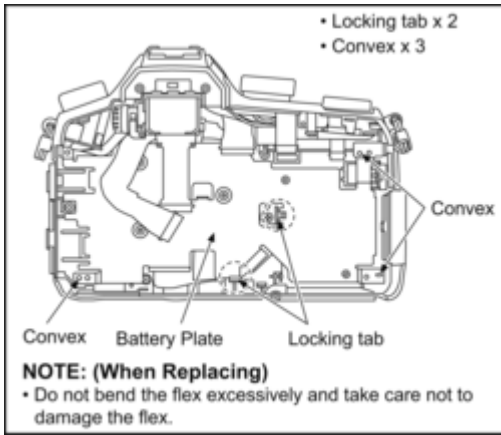

(Fig. D6)

### 9.3.4 Removal of the Top Case Unit and Battery Case Unit

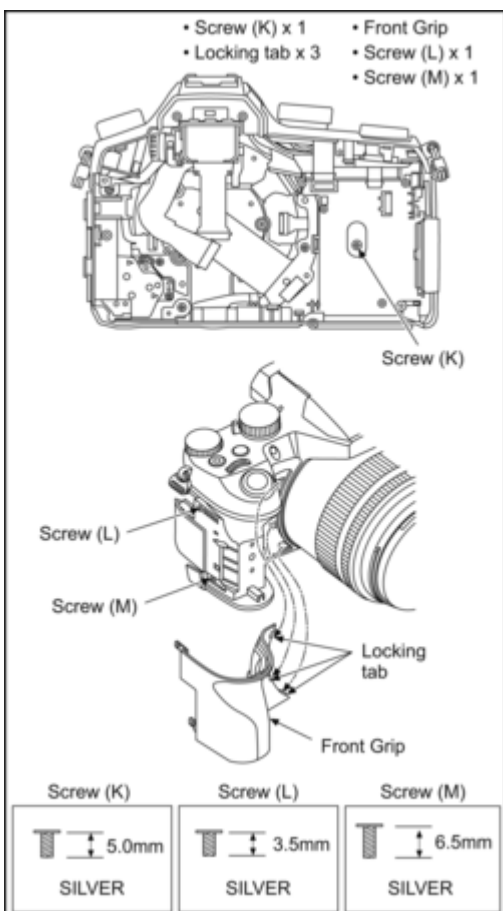

(Fig. D7)

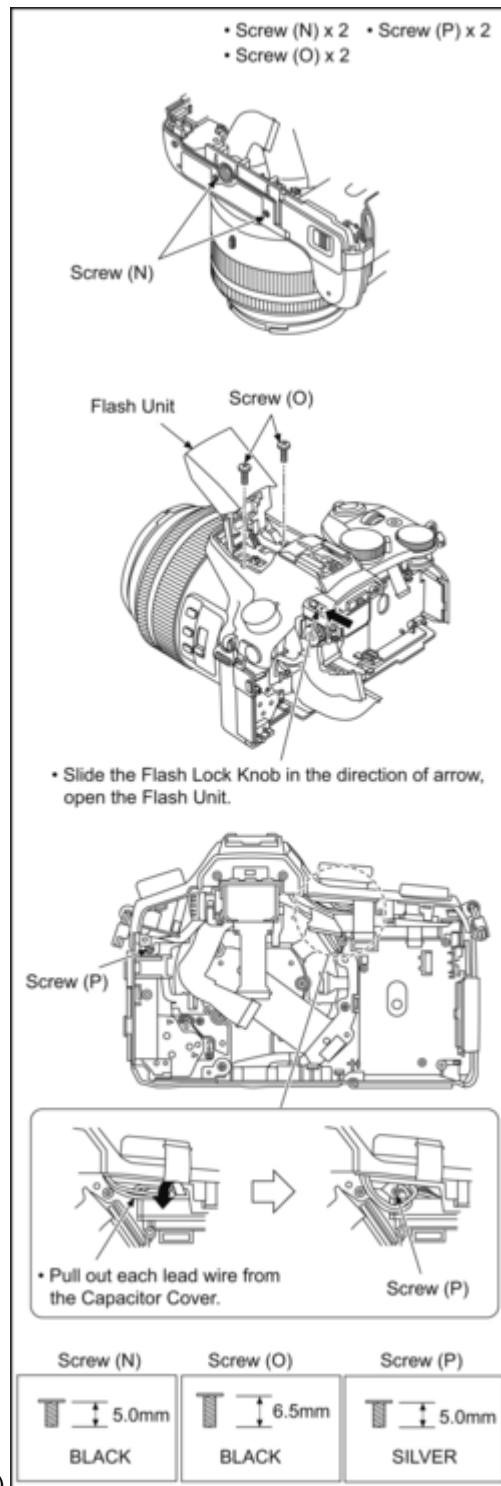

(Fig. D8)

(Fig. D9)

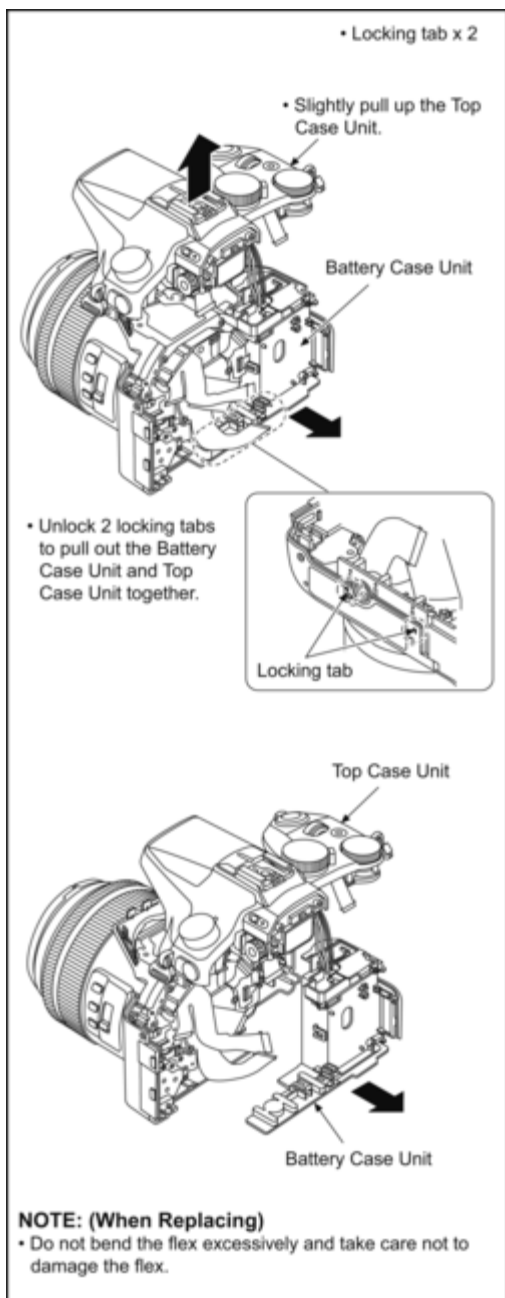

(Fig. D10)

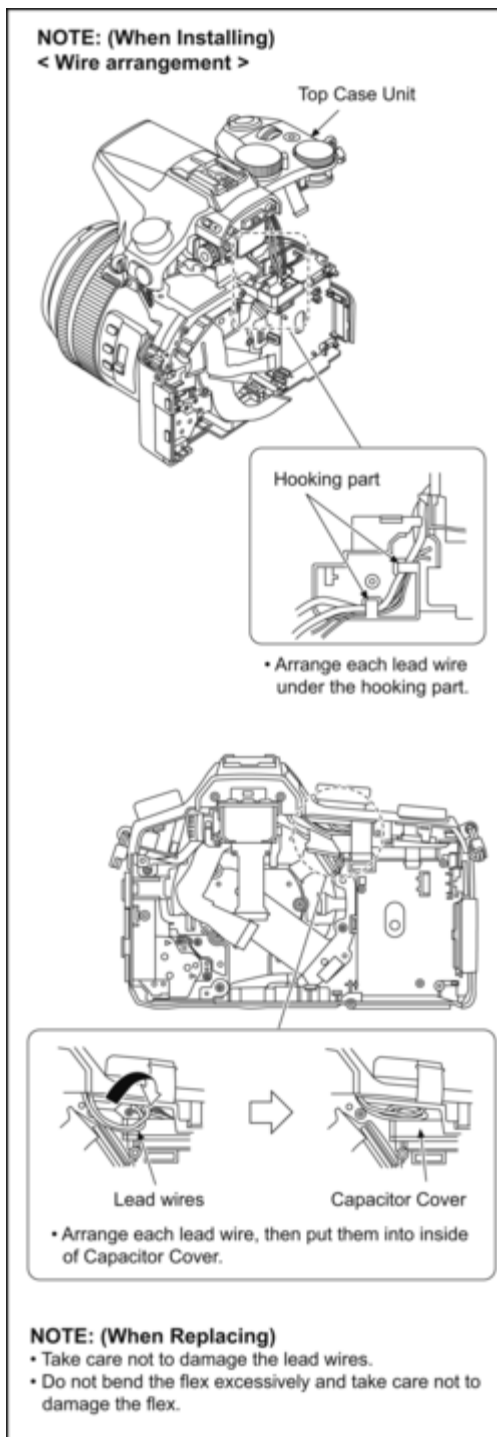

### 9.3.5 Removal of the Zoom Motor and Lens Unit

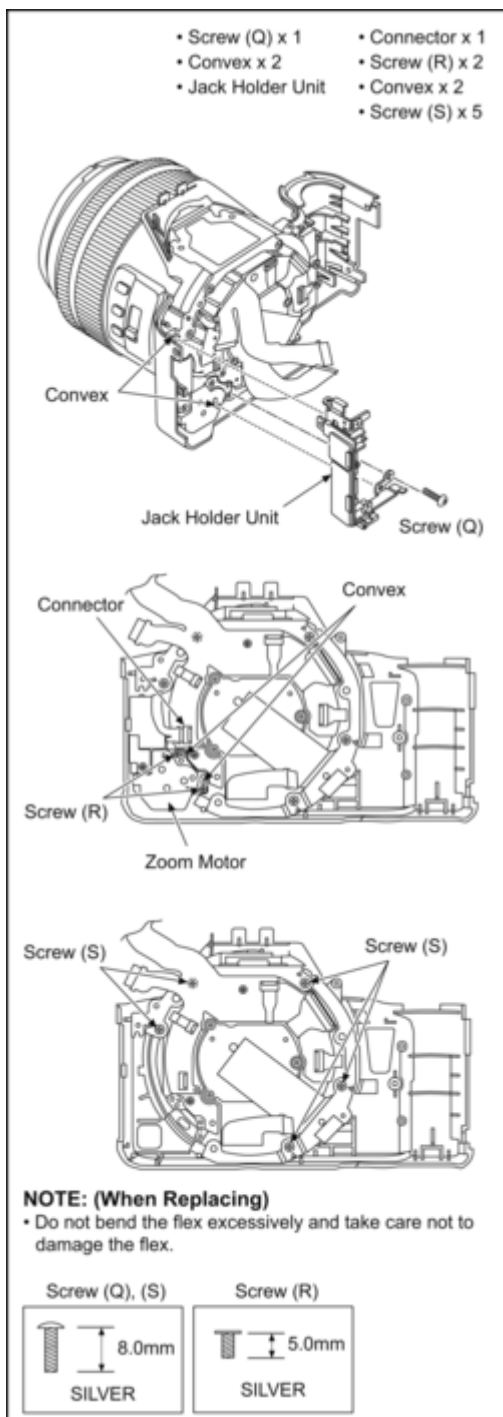

(Fig. D11)

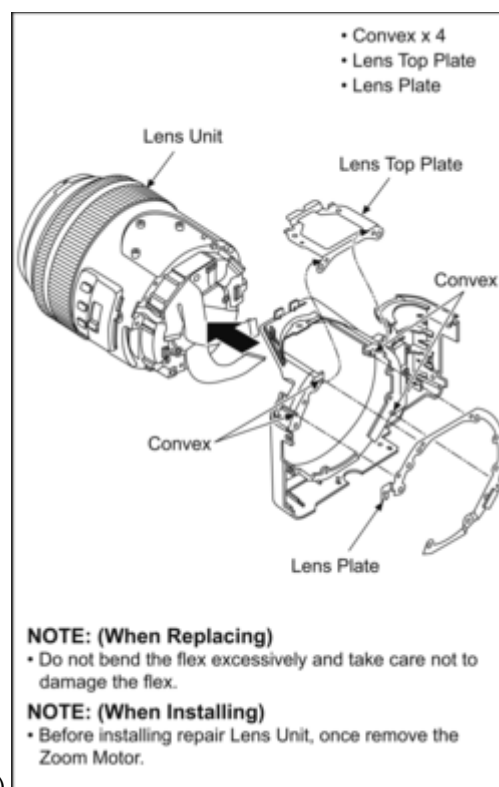

(Fig. D12)

### 9.3.6 Removal of the Battery Door Unit

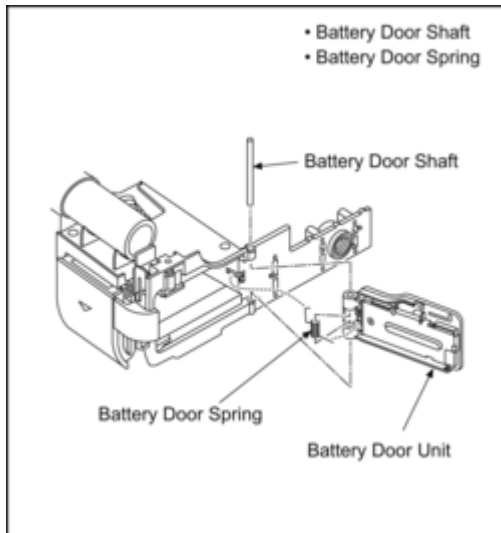

(Fig. D13)

### 9.3.7 Removal of the Flash P.C.B. Unit

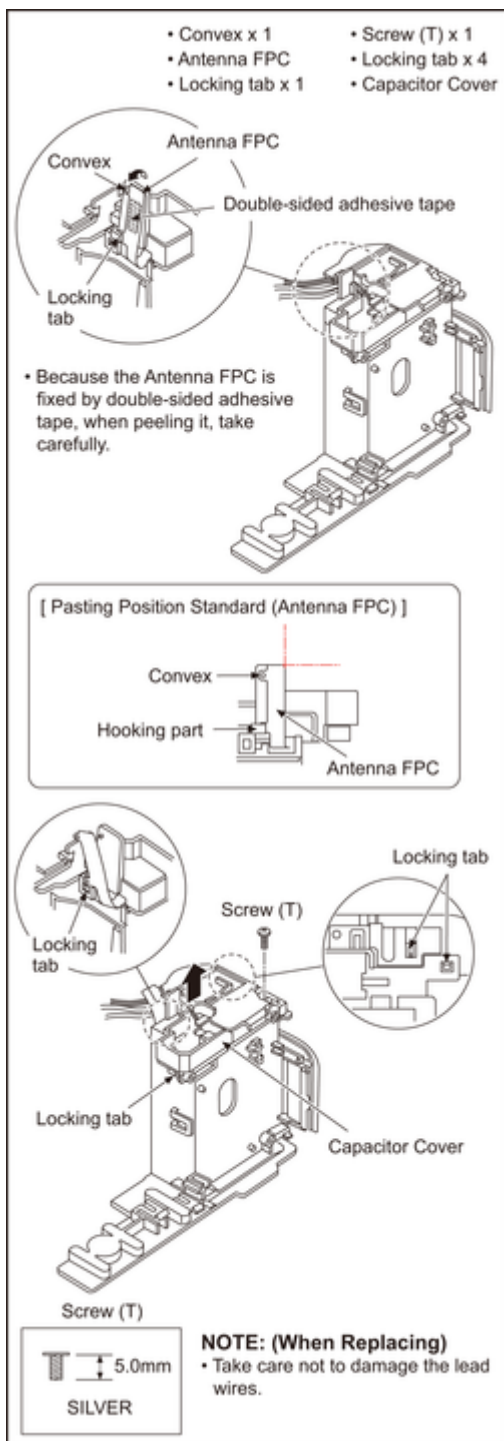

(Fig. D14)

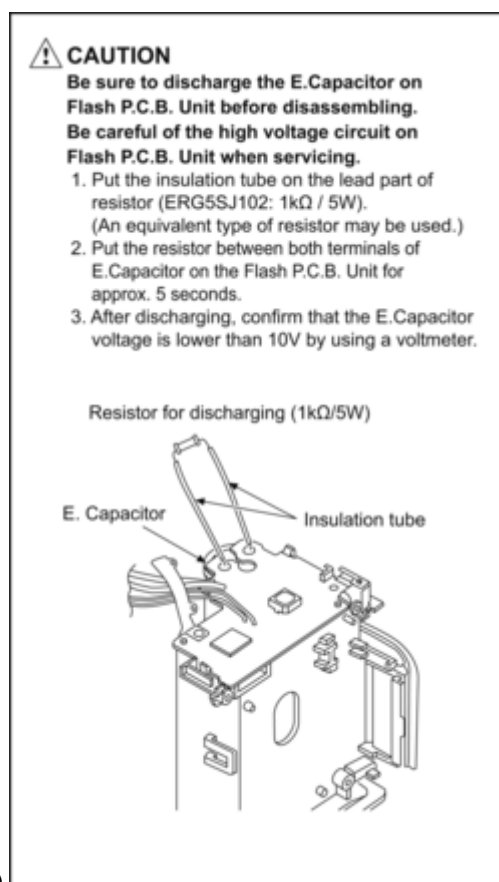

(Fig. D15)

(Fig.

**IMPORTANT NOTICE:**

- Take care not apply any bending load to the charging E.Capacitor. It brings about the possibility of Flash P.C.B. Unit and/or component on the Flash P.C.B. Unit.

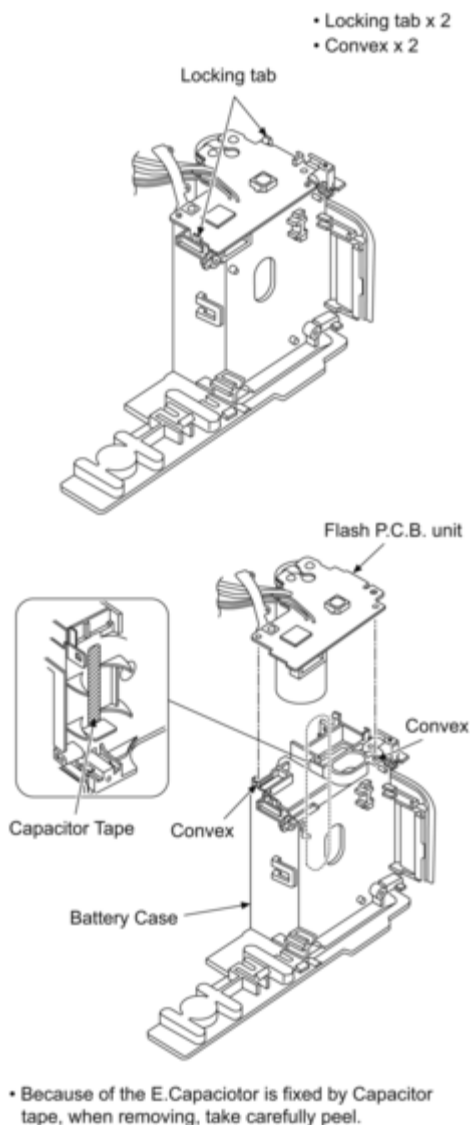
**NOTE: (When Replacing)**

- Take care not to damage the lead wires.

D16)

**9.3.8 Removal of the LVF Unit**



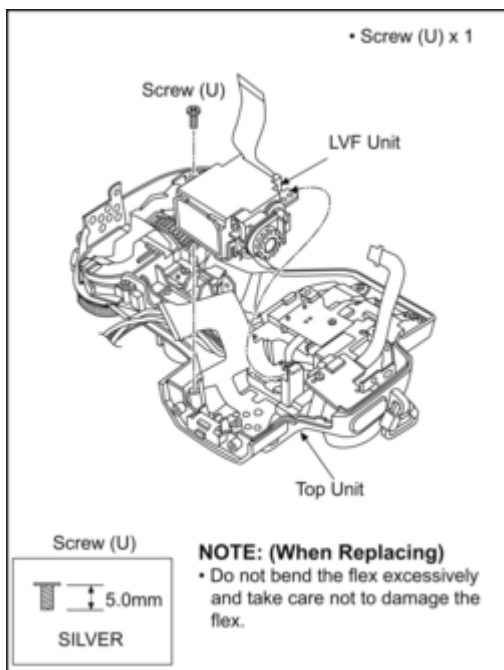

(Fig. D17)

### 9.3.9 Removal of the Flash Unit

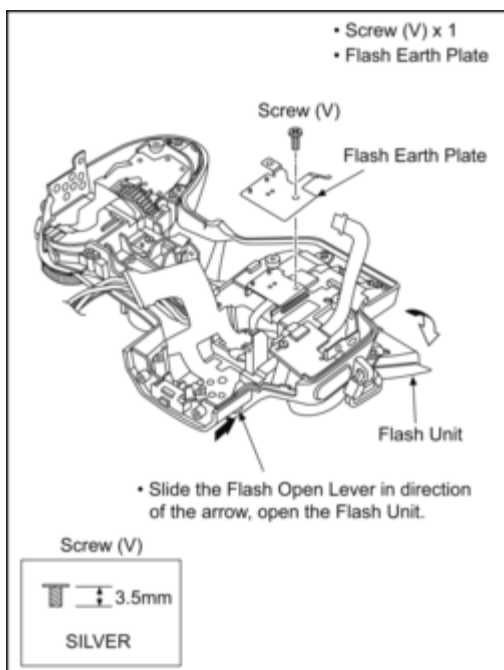

(Fig. D18)

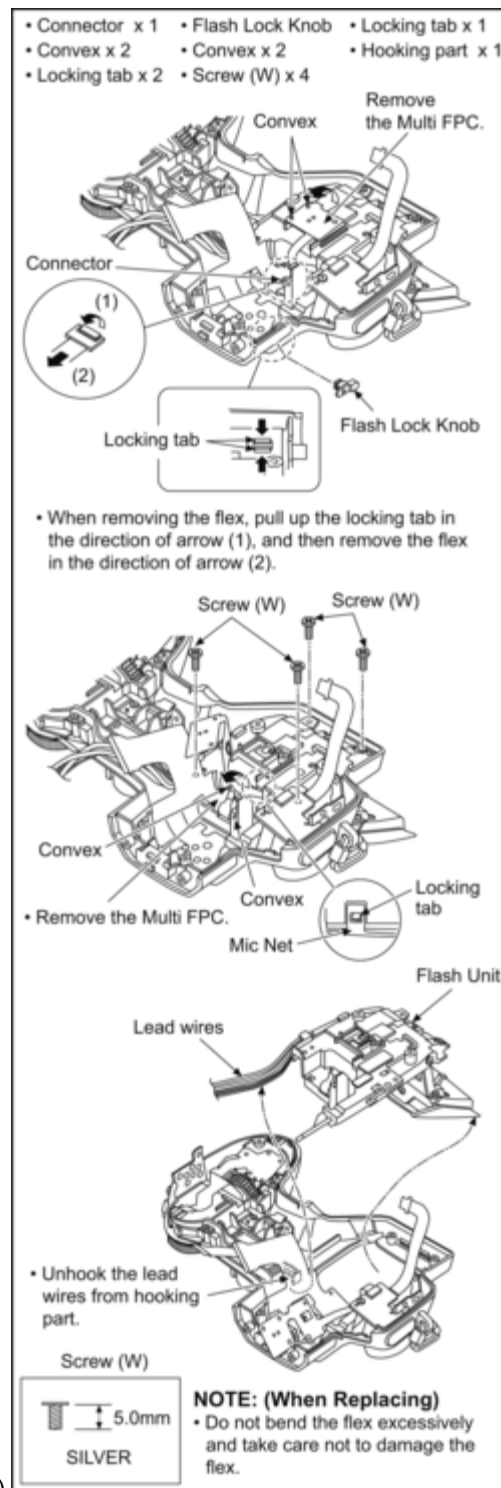

(Fig. D19)

### 9.3.10 Removal of the Flash Case Top

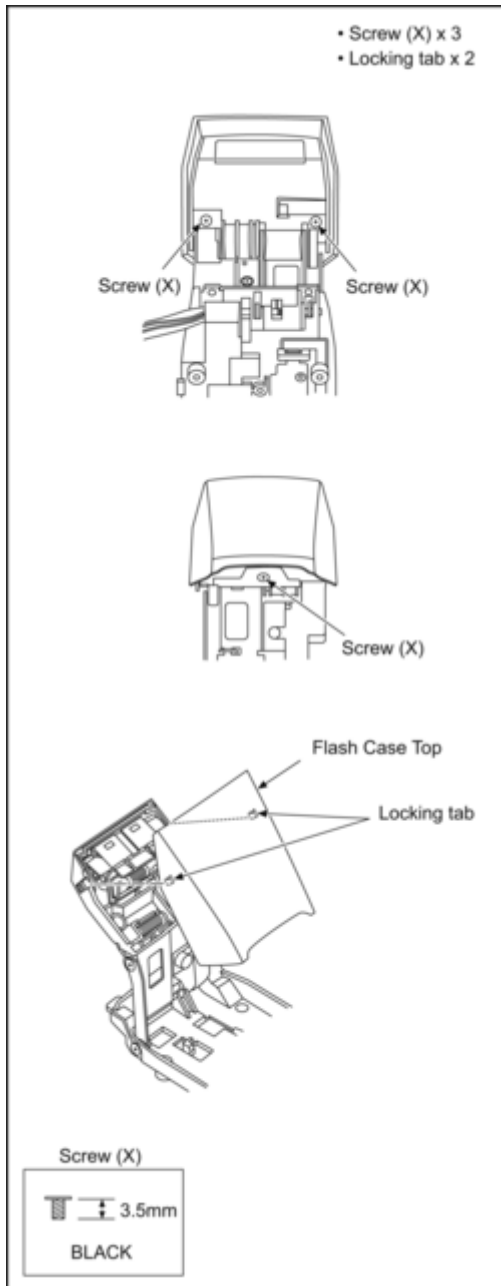

(Fig. D20)

### 9.3.11 Removal of the Hot Shoe Unit, Multi FPC and Mic Net

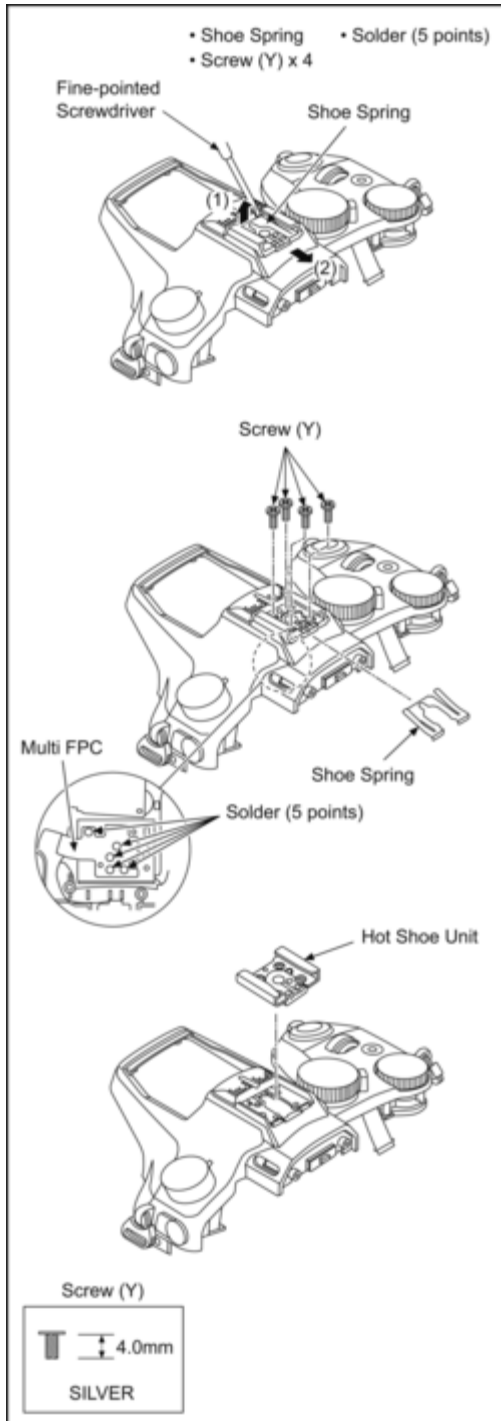

(Fig. D21)

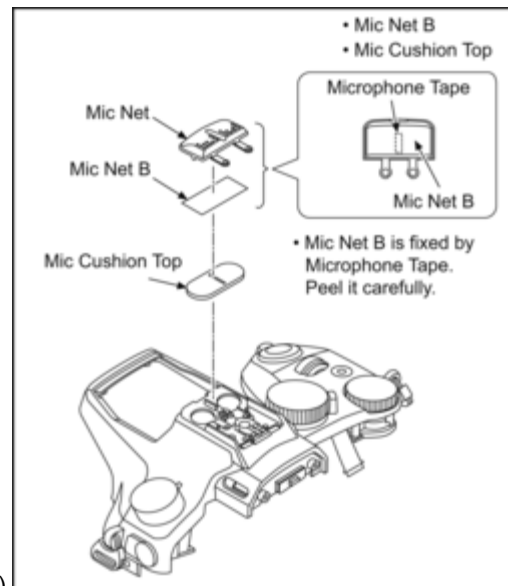

(Fig. D22)

### 9.3.12 Removal of the LCD IF P.C.B. and LCD Top Case Unit

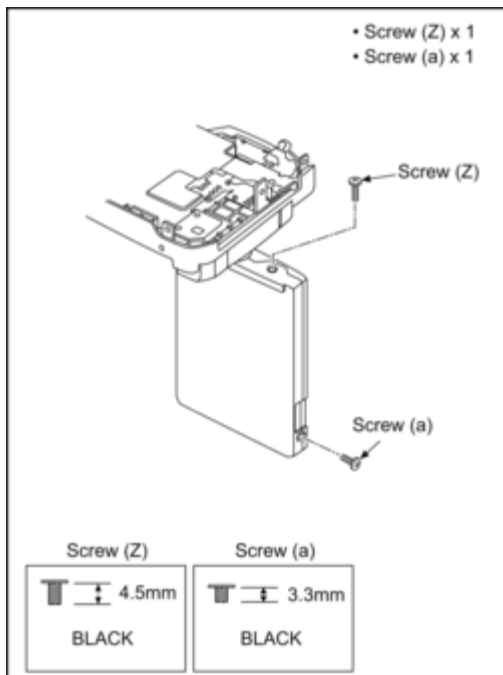

(Fig. D23)

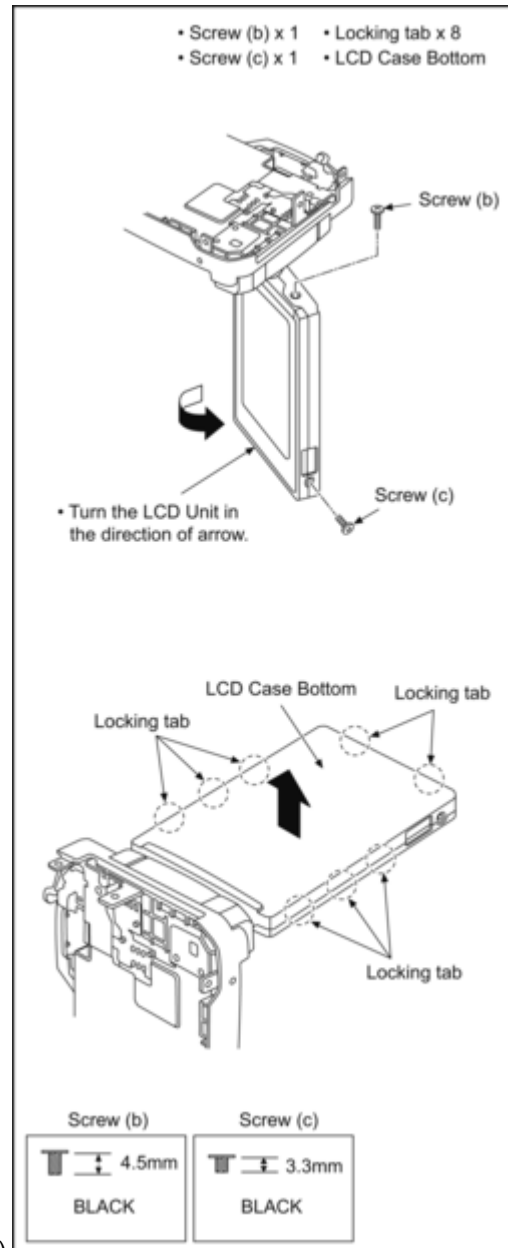

(Fig. D24)

(Fig.

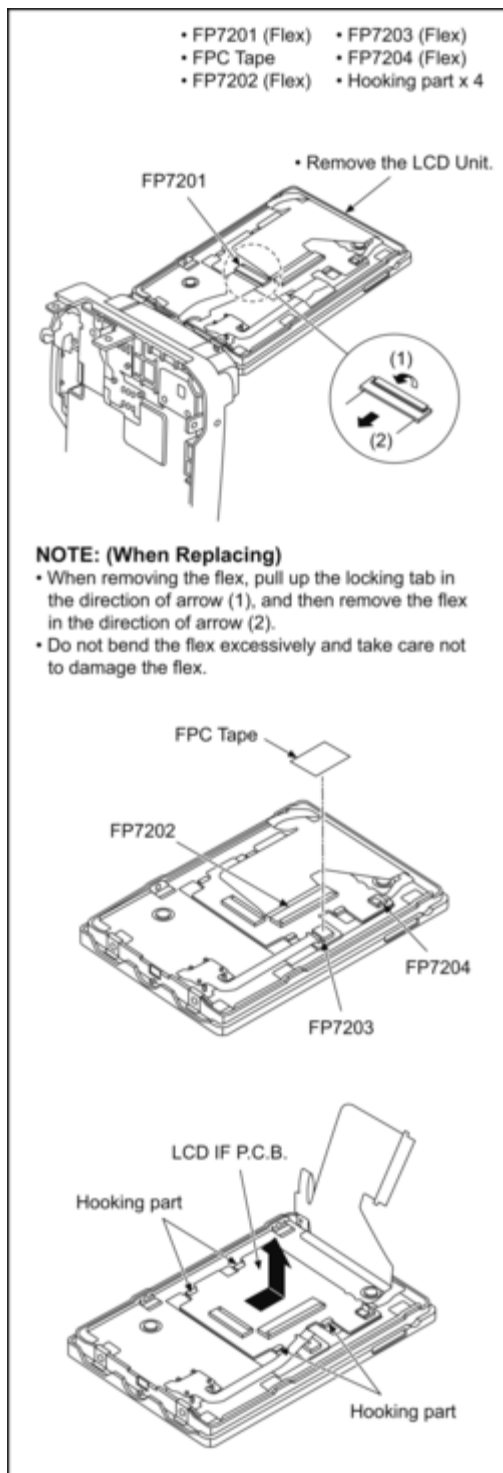

D25)

(Fig. D26)

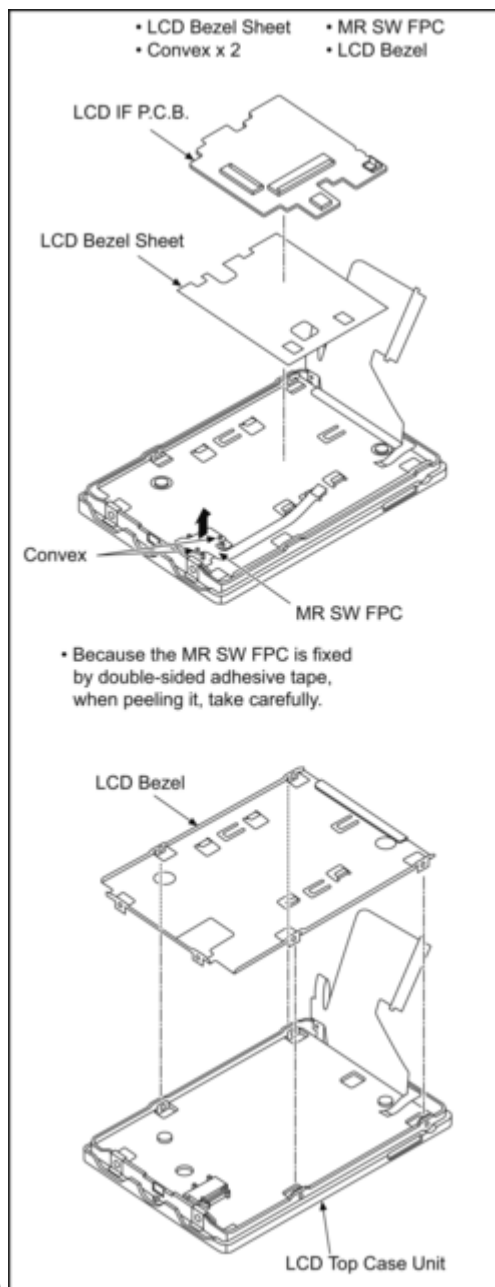
**NOTE: (When Installing)**

Make sure to confirm the following points when installing:

- The screw is tightened enough.
- Installing conditions are fine. (No distortion, no abnormal-space.)
- No dust and/or dirt on lens surfaces.
- LCD image is fine. (No dust and/or dirt on it, and no gradient images.)

## 9.4 Lens Disassembly Procedure

**Precaution:**

1. Do not remove the MOS Unit when disassembling or reassembling the lens in order to maintain it clean.  
When remove it, refer to item "9.7."
2. Keep dust or dirt away from the lens.  
To remove dirt or dust from the lens, blow with dry air.
3. Do not touch the lens surface.
4. Use Lens Cleaning Kit (VFK1900BK).
5. Do not bend the flex excessively and take care not to damage the flex.
6. Apply grease to surely the specified position as shown in the figure on item "9.6".

**9.4.1 Removal of the Lens FPC Unit**

1. Peel the Radiation Sheet
2. Unconnect the 4 connectors each flex.

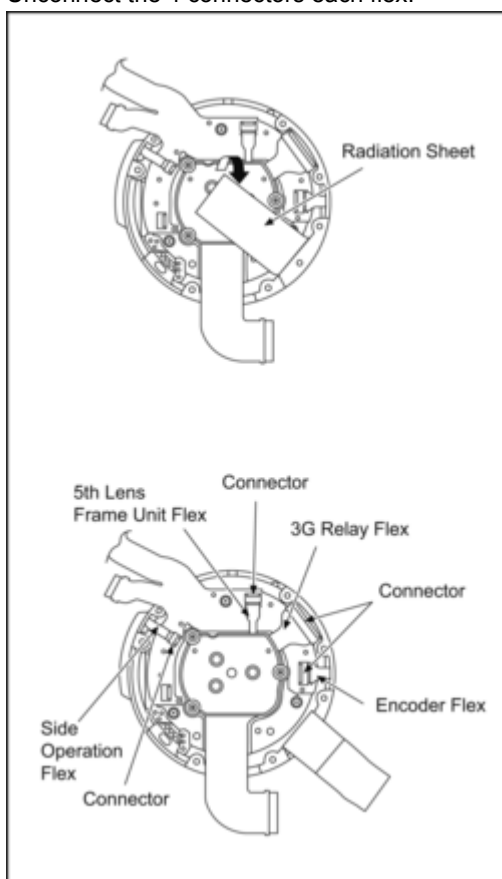

3. Remove 8 covexes.

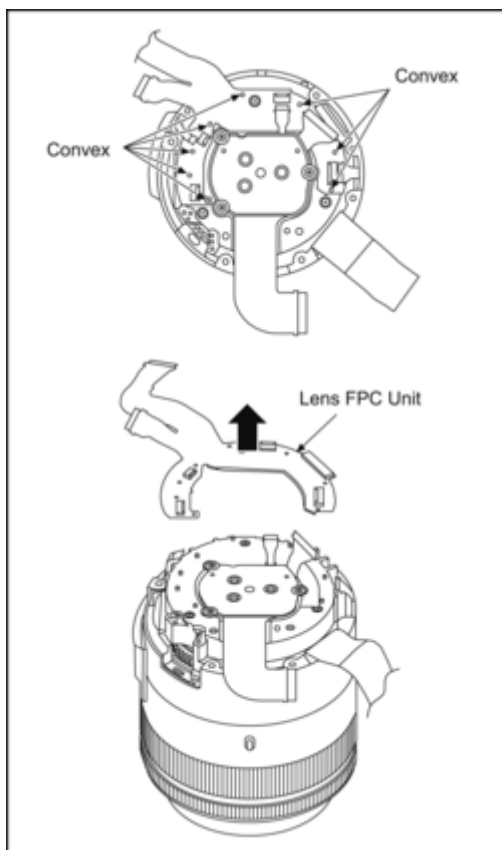

## 9.4.2 Removal of the Lens Exterior Unit

1. Unscrew the 3 screws (A).

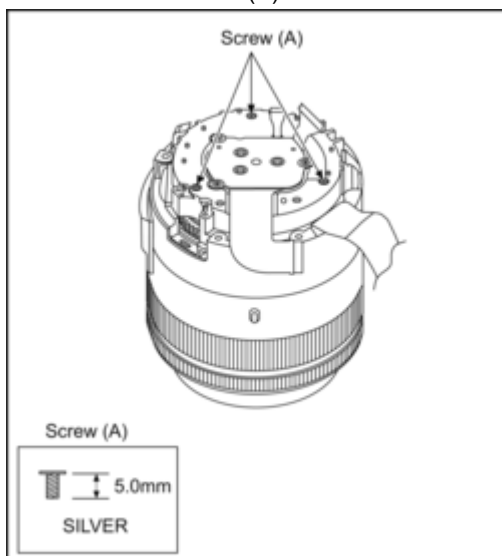

2. Remove the Lens Exterior Unit.



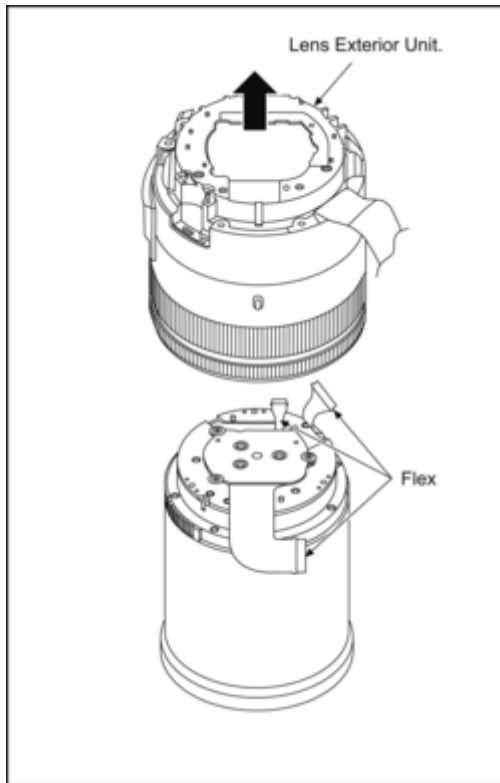

### 9.4.3 Removal of the 1st Lens Frame Unit

1. Stand up with the lens side of 1st Lens Frame Unit up.
2. Fully rotate the Cam Frame Unit clockwise.

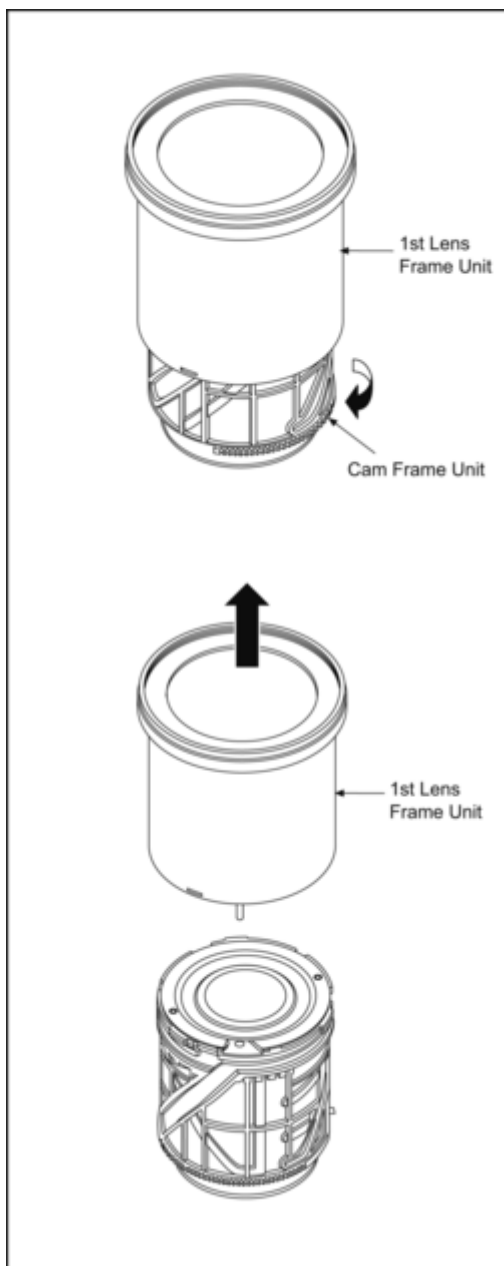

#### 9.4.4 Removal of the Cam Frame Unit

1. Rotate the Cam Frame Unit and remove it upward.

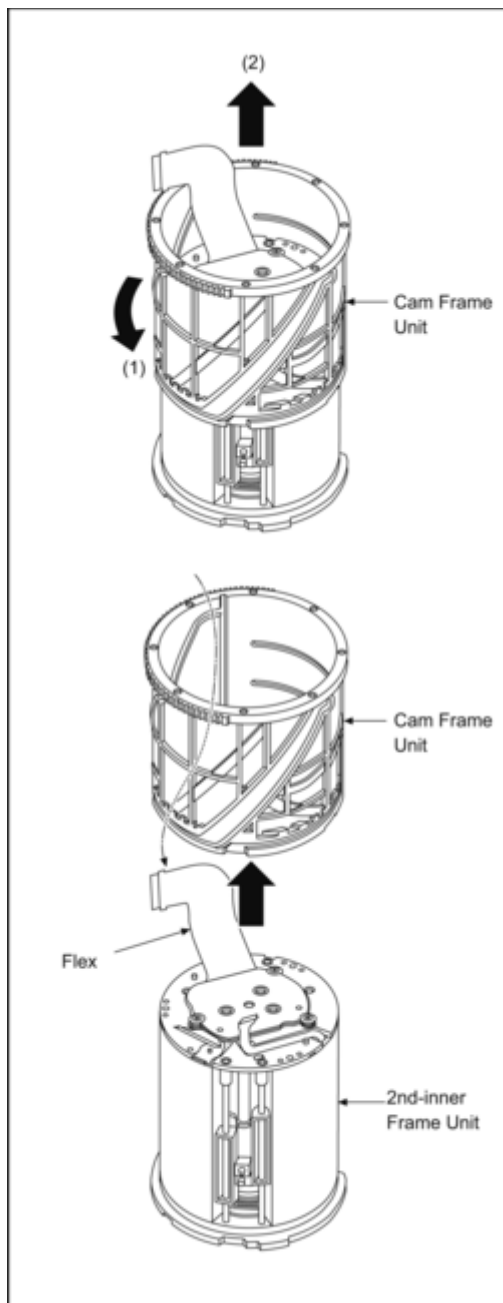

#### 9.4.5 Removal of the 4th-5th Lens Frame Unit

1. Remove the 3G Relay Flex from convex.
2. Insert the thin screwdriver in turn into 5 grooves and lift the 4th-5th Lens Frame Unit little by little.
3. Remove the 4th-5th Lens Frame Unit from 4 guide poles straight up.

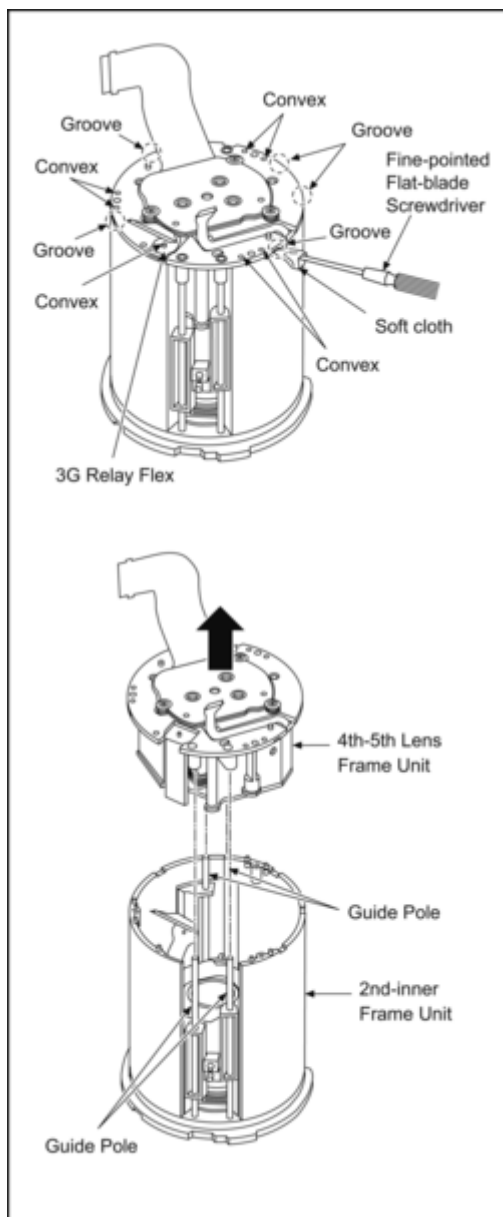

#### 9.4.6 Removal of the 3G Shutter Unit

1. Lift the 3G Shutter Unit convex and recessed portion same time, remove the 3G Shutter Unit.

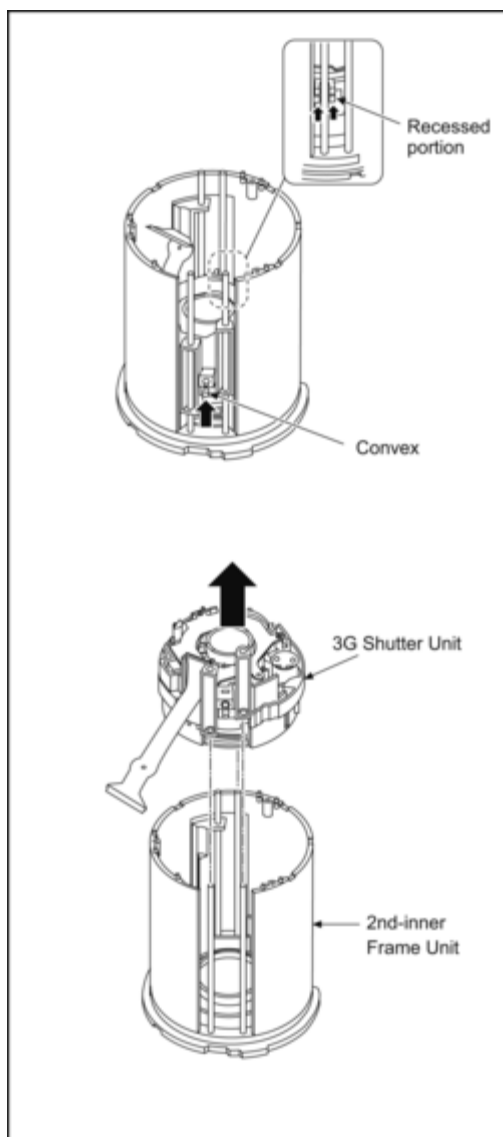

#### 9.4.7 Removal of the Side Operation Unit, Lens Exterior Unit, Rear Ring

1. Unscrew the Screw (B).
2. Remove the Side Operation Unit in the direction of arrow.

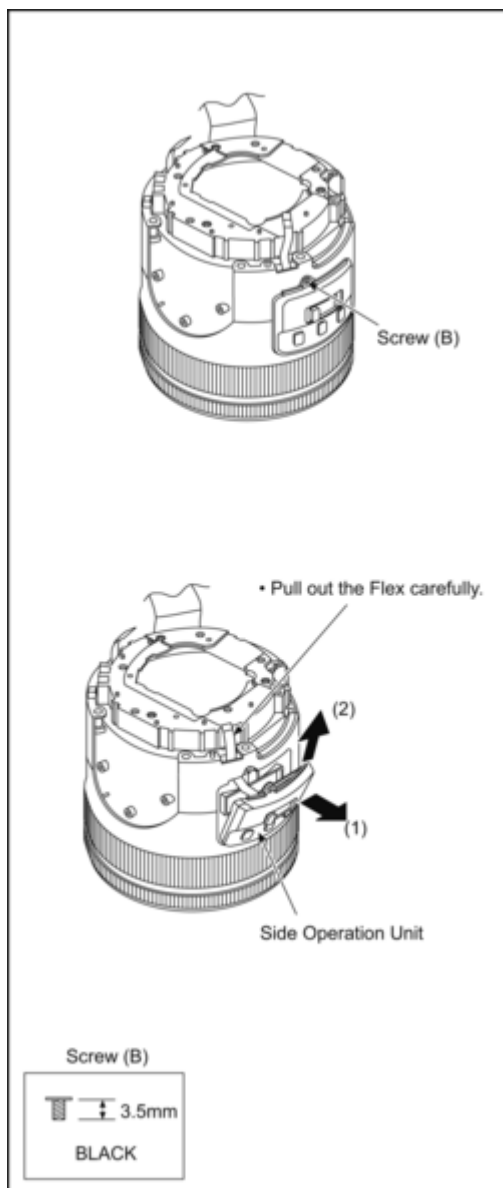

3. Remove the Rear Ring and Earth Plate upward.
4. Using flat-blade screwdriver, pressing the 3 locking tabs of wave washer, remove the Wave Washer.

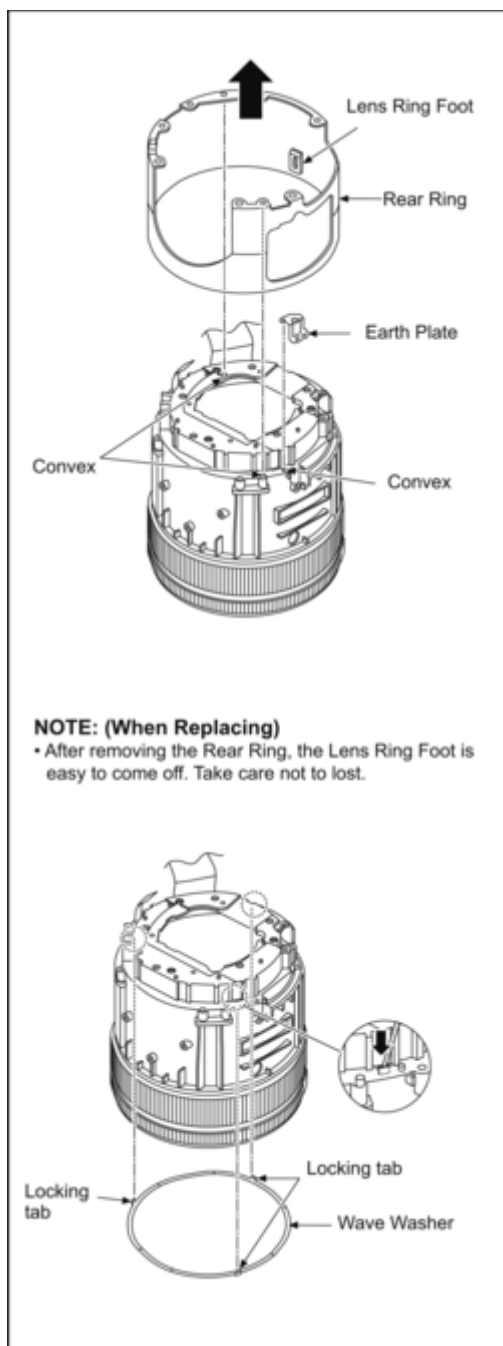

## 9.5 Assembly Procedure for the Lens

### Precaution:

1. Do not remove the MOS Unit when disassembling or reassembling the lens in order to maintain it clean. When remove it, refer to item "9.7."
2. Keep dust or dirt away from the lens. To remove dirt or dust from the lens, blow with dry air.
3. Do not touch the lens surface.
4. Use Lens Cleaning Kit (VFK1900BK).
5. Do not bend the flex excessively and take care not to damage the flex.

6. Apply grease to surely the specified position as shown in the figure on item "9.6".
7. For items that are not in the assembly procedure, follow the reverse procedure of disassembly procedure.

### 9.5.1 Assembly of the 3G Shutter Unit

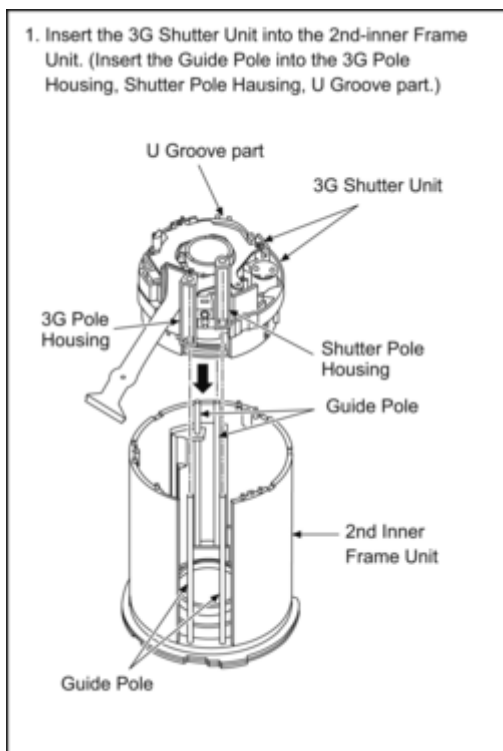

### 9.5.2 Assembly of the 4th-5th Lens Frame Unit



1. Insert the 4th-5th Lens Frame Unit into 2nd-inner Frame Unit. (Insert the Guide Pole into the Guide Pole Catcher of the 4th-5th Lens Frame Unit.)
2. Push the 4th-5th Lens Frame Unit until convexes (7 points) is completely fitted.

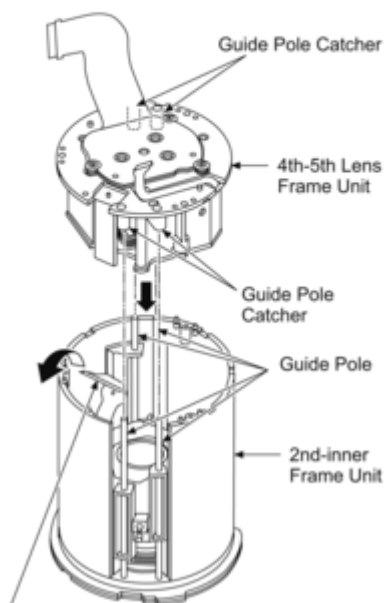

**NOTE: (When Installing)**

- Leave the end of the 3G Relay Flex out to the outer periphery.

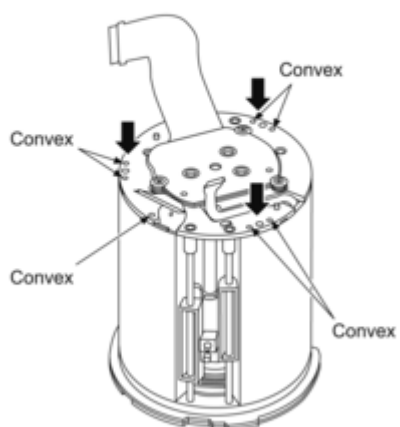

### 9.5.3 Assembly of the Cam Frame Unit

1. Insert the Cam Frame Unit into 2nd-inner Frame Unit.  
(Align the groove of Cam Frame Unit and convex of 2nd-inner Frame Unit, then Insert the Cam Frame Unit.)
2. When inserting, take care not to pinch the 3 Flexes.
3. After insertion completed, rotate the Cam Frame Unit about 2 degrees in the direction of arrow.

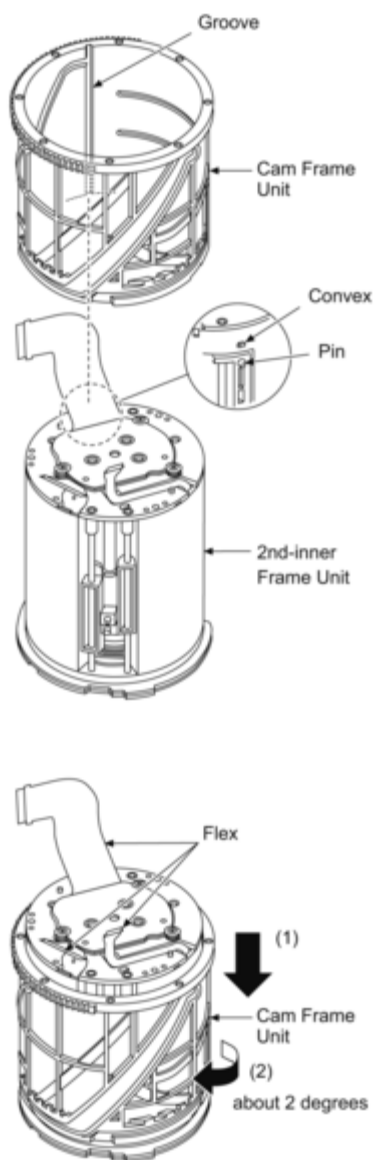

#### 9.5.4 Assembly of the 1st Lens Frame Unit

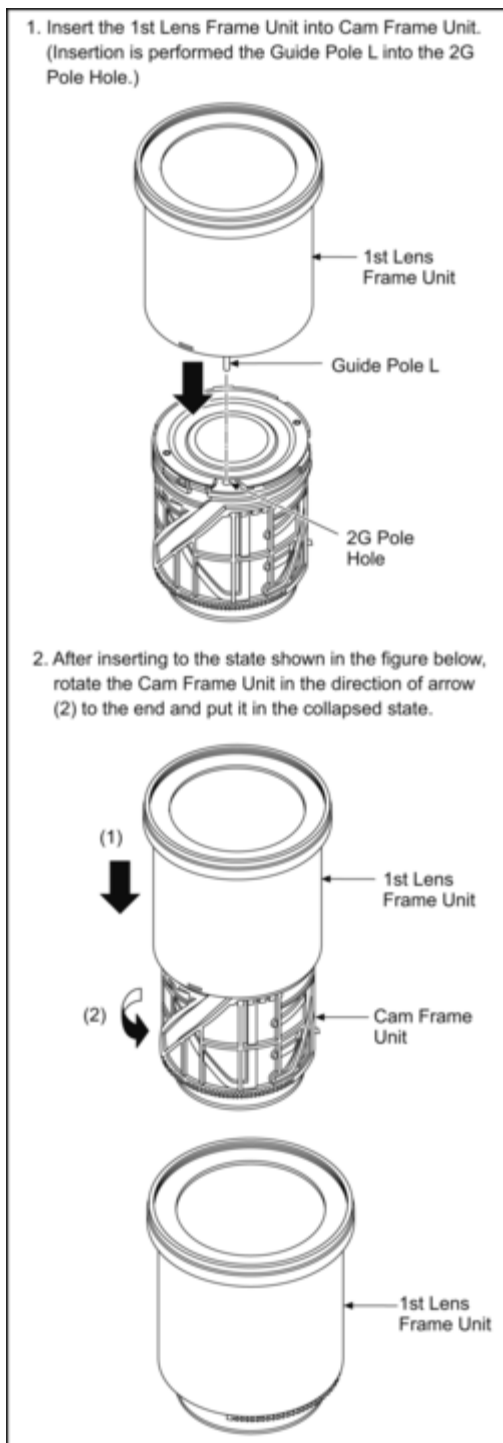

### 9.5.5 Assembly of the Lens Exterior Unit

1. Press-fit positioning hole of the 3G Relay Flex into convex.
2. Rotate the Cam Frame Unit about 80 degrees in the direction of arrow to put it in the WIDO state.
3. Insert the Lend Exterior Unit into the Cam Frame Unit. (Be careful not to pinch the flex.)
4. Tighten 3 screws (A).

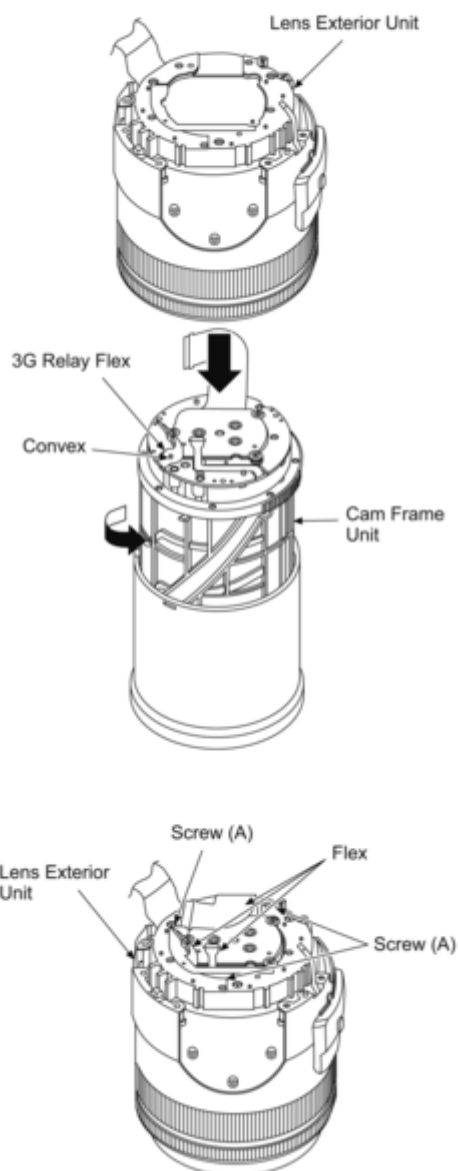

## 9.6 The Application of Grease Method

The grease application parts of lens unit are as follows.  
 Apply grease additionally in the specified position if necessary.  
 When the grease is applied, use a toothpick and apply thinly.

- Sliding points of Wave Washer
  - Grease: RFKZ0472
  - Amount of application:  $1.0 \pm 0.1$  mg (8 points)

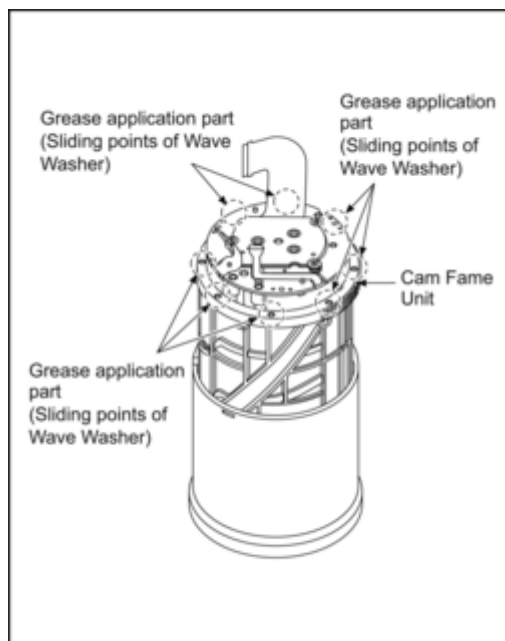

## 9.7 Removal of the MOS Unit

**\* If the MOS Unit removed once (the screw (C) is loosened even a little), the optical tilt adjustment is required.**

**When loosen the screw (C), necessary the optical tilt adjustment at the end of assembling.**

**(Refer to item "10.3.2.")**

- To prevent the MOS Unit from catching the dust and dirt, do not remove the MOS Unit except for replacing.
1. Peel the Radiation Sheet.
  2. Unscrew the 3 screws (C).
  3. Remove the MOS Unit.

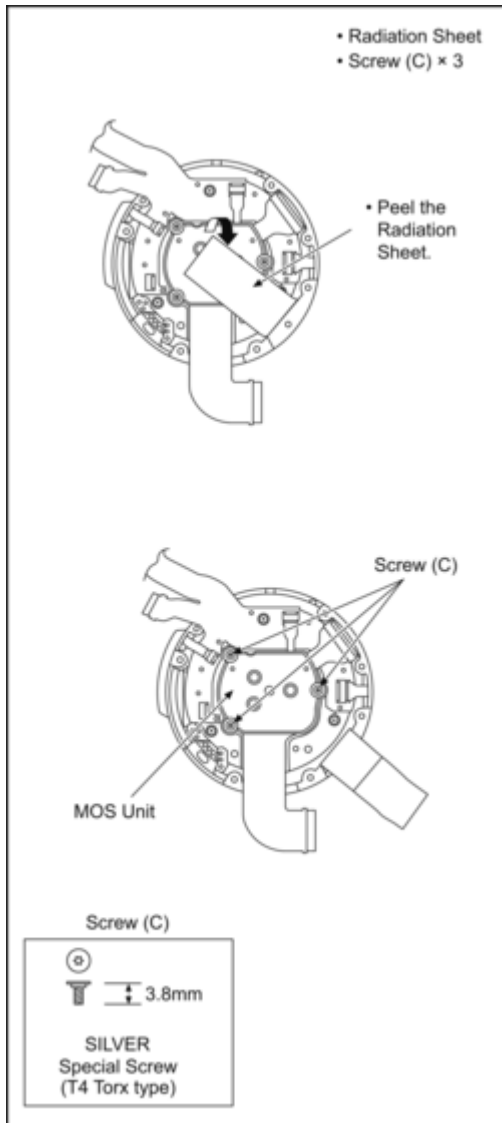

4. Remove the 3 Tilt Springs.

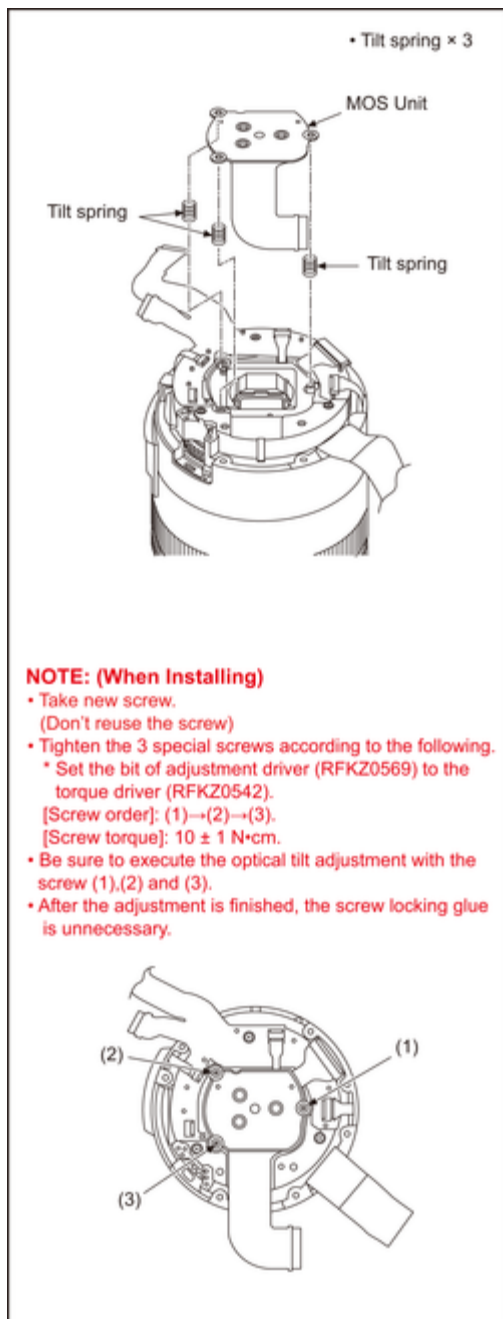

# 10 Measurements and Adjustments

## 10.1 Introduction

When servicing this unit, make sure to perform the adjustments necessary based on the part(s) replaced. Before disassembling the unit, it is recommended to back up the camera data stored in Flash-ROM as a data file.

**NOTE: (When replacing the Lens unit and MOS unit)**

- When the MOS unit is unavoidably removed for Lens unit and MOS unit replaced, an optical tilt adjustment is necessary after parts are exchanged.
- The adjustment software (DSC\_Tilt) is necessary to execute an optical tilt adjustment.
- The adjustment software "DSC\_Tilt" is available at "TSN Website".

**NOTE: (When replacing the Main P.C.B.)**

- Number of necessary adjustment items decreases by copying the backup data to new Main P.C.B. when adjustment data in old Main P.C.B. can be read by ROM\_BACKUP "DSC→SD" in "10.2.2. Flash-Rom Data Backup".  
For more details, please refer an item "MAIN P.C.B. (When written the Backup data)" in the table of "10.3.2. Adjustment Specifications".

**IMPORTANT NOTICE (After replacing the Main P.C.B.)**

After replacing the Main P.C.B., it is necessary to achieve adjustment.

## 10.2 Before Disassembling the unit

### 10.2.1 Initial Setting Release

The cameras specification are initially set in accordance with model suffix (such as EB/EG/GK and so on.). Unless the initial setting is not released, an automatic alignment software in the camera is not able to be executed when the alignment is carried out.

**Note:**

The initial setting should be again done after completing the alignment. Otherwise, the camera may not work properly. Therefore as a warning, the camera display a warning symbol "!" on the LCD monitor every time the camera is turned off. Refer to the procedure described in "3.5.2. Initial Settings" for details.

**[ How to Release the camera initial setting ]**

**Preparation:**

- Attach the fully charged Battery, and insert the memory card.
- Remove the lens cap.

**Step 1. The temporary cancellation of "Initial Settings":**

Set the mode dial to "[ P ] (Program AE mode)", and drive mode dial to "[ Single ]". While keep pressing [ AF/AE LOCK ] button and [ DISP. ] button simultaneously, turn the power on.

**Step 2. Cancellation of "Initial Settings":**

Press the [ Playback ] button in order to enter the [ Playback ] mode. Press [ AF/AE LOCK ] button and "[ UP ] of Cursor buttons" simultaneously, then turn the power off. The LCD displays the "!" mark before the unit powers down.

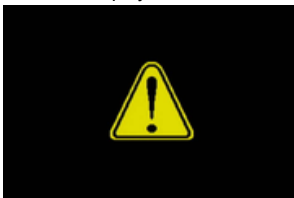

### 10.2.2 Flash-ROM Data Backup

Number of necessary adjustment items decreases by copying the backup data to new Main P.C.B. when adjustment data in old Main P.C.B. is usually read by ROM\_BACKUP "DSC→SD". It is recommended to backup the Flash-ROM data as the way of return when trouble occurs before disassembling the unit depending on each case.

**[ ROM\_BACKUP (Method of Non-PC backup) ]**

1. Insert the memory card into the unit.
2. Set the camera to "Temporary cancellation of the initial settings".
3. Select the "SETUP" menu.  
From the "SETUP" menu, select "ROM\_BACKUP".



**NOTE:**

This item is not listed on the customer's "SETUP" menu.

4. When this "ROM\_BACKUP" item is selected, the following submenus are displayed.



Fig.2-1

Item	Function	Details
DSC → SD	Save all the DSC's Flash-ROM data to Memory Card	<ul style="list-style-type: none"> <li>DSC's Flash-ROM data is saved to the Memory Card as a data file. (DATA BACKUP)</li> <li>File location: ROOT DIRECTORY in Memory Card.</li> <li>File Name:                             <ul style="list-style-type: none"> <li>1) User Setup Information data: &lt;Model No.&gt;U.TXT [Depending on the model, more than one file may be generated (e.g. &lt;Model No.&gt;U.TXT and &lt;Model No.&gt;U3.TXT).]</li> <li>2) Electrical Adjustment data: &lt;Model No.&gt;F.TXT [Depending on the model, more than one file may be generated (e.g. &lt;Model No.&gt;F.TXT and &lt;Model No.&gt;F3.TXT).]</li> </ul> </li> <li>If the concerned file already exists, "OVERWRITE?" message is displayed.</li> </ul>
SDALL → DSC (ID CHECK)	Write the all data to DSC's Flash-ROM from Memory Card	<ul style="list-style-type: none"> <li>The backup data stored in the Memory Card is transferred to DSC unit.</li> <li>ID CHECK: When the model ID is different, data is not transferred.</li> <li>FORCE: Even if the model ID is different, data is transferred.</li> <li>If the Main P.C.B. is replaced, select "SDALL → DSC (FORCE)".</li> </ul>
SDALL → DSC (FORCE)	Write the all data to DSC's Flash-ROM from Memory Card	<ul style="list-style-type: none"> <li>Only "User setup information" is written from the saved file in the Memory Card to DSC's Flash-ROM</li> <li>Only the user's "setup" setting condition is transferred to DSC unit.</li> <li>FORCE: Even if the model ID is different, the data is not transferred.</li> </ul>
? → LUMIX	Shipping set without initializing "User setup information"	<ul style="list-style-type: none"> <li>Initial setting is executed without initializing the user's set up setting condition.</li> <li>The initial setting must be performed while the Self-timer LED is blinking.</li> <li>The picture data stored in the built-in memory of the DSC is not erased, with this operation.</li> </ul>
ADJFLAG → ALL F	Set all adjustment flags completion	<ul style="list-style-type: none"> <li>Status of the all adjustment flags are changed to "F" (completion).</li> </ul>
WBADJ → STEPMODE	ISO: Adjustment WBL, WBM: Setting	<ul style="list-style-type: none"> <li>ISO: Sensitivity adjustment.</li> <li>WBL: Setting up the white in low color temperature.</li> <li>WBM: Setting up the white in high color temperature.</li> </ul>
STEPMODE → WBADJ	Cancel "STEPMODE"	<ul style="list-style-type: none"> <li>Cancel the "STEPMODE" mode.</li> </ul>

**10.2.3 About Light Box**

**When using VFK1164TDVLB Light Box**

If using VFK1164TDVLB Light Box, remove the lens connection ring by loosening thumbscrew and three hexagon screws.

\* RFKZ0523 Light Box has no lens connection ring.

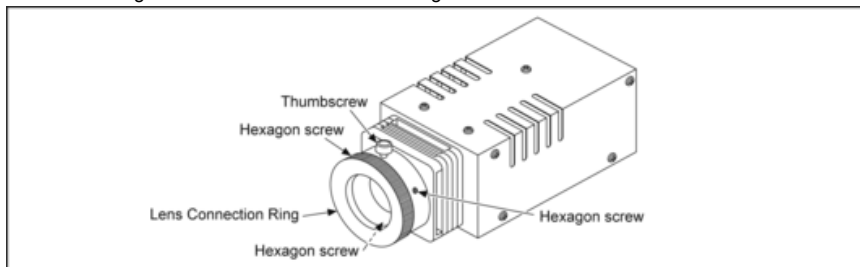

**How to remove the Front Hood**

In order to utilize maximum of the diffusing surface of Light Box, some adjustment items need the distance between diffusing surface of Light Box and camera body becomes several centimeters.

Before the adjustments, remove the front hood of Light Box following steps below.

[ For VFK1164TDVLB Light Box ]

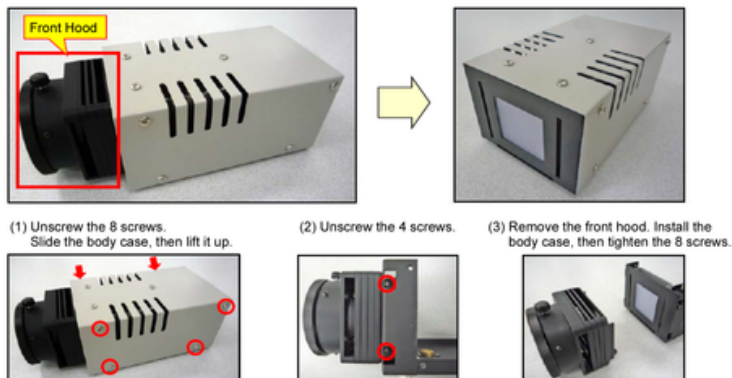

[ For RFKZ0523 Light Box ]

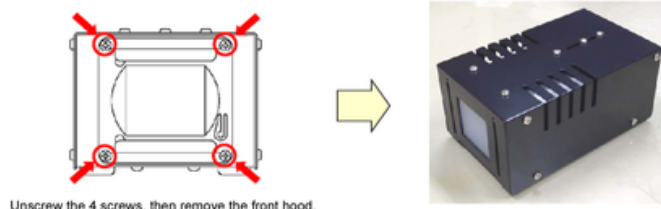

Unscrew the 4 screws, then remove the front hood.

## 10.3 Details of Electrical Adjustment

### 10.3.1 How to execute the Electrical Adjustment

It is not necessary to connect the camera to a PC to perform adjustments.

“Flag reset operation” and “Initial setting operation” are required when carrying out the alignment, follow the procedure below.

#### 10.3.1.1 Startup Electrical Adjustment mode

1. Release the initial settings.
2. Insert a recordable memory card.  
(Without a memory card, the automatic adjustment can not executed.)
3. Set the mode dial to “[ P ] (Program AE mode)”.
4. Procedure to set the camera into adjustment mode:  
Turn the Power on pressing [ Q.MENU/Fn5 ] button, and  
[ (Delete/Cancel)/Fn6 ] button simultaneously.  
LCD monitor displays “SERVICE MODE”. (Refer to Fig. 3-1)

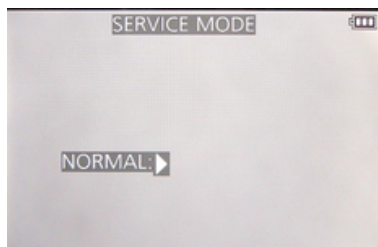

Fig.3-1

#### 10.3.1.2 Status Adjustment Flag Setting

Reset (Not yet adjusted) the status flag condition.

1. Press the [ DISP. ] button, the LCD monitor displays the Flag status screen. (Refer to Fig.3-2)
2. Select item by pressing the Cursor buttons. (Gray cursor is moved accordingly.)
3. Press the [ (Delete/Cancel)/Fn6 ] button.

#### NOTE:

The selected item's flag has been changed from  
“F (green)” to “0 (yellow)”.

\*Flag conditions:

F (green)

means that the alignment has been completed and the status flag condition is set. In this case, the flag condition should be reset, if you try to carry out the automatic alignment.

0 (yellow)

means that the alignment has been not “completed” and the status flag condition is “reset”. In this case, automatic alignment is available.



Fig.3-2

- In case of setting the status flag into set condition again without completion of the alignment, the status flag should be UNDO by using ROM BACKUP function.

#### 10.3.1.3 Execute Adjustment (In case of “OIS Adjustment”)

1. Perform step "10.3.1.1." to "10.3.1.2.", to reset the OIS flag status "F" (Set) to "0" (Reset)
2. Press "[ DISP. ] button" after Flag reset.  
OIS Adjustment screen is displayed on the LCD panel. (Refer to Fig.3-3)
3. Press the [ Shutter ] button.  
The adjustment will start automatically.
4. When the adjustment is completed successfully, adjustment report menu appears with Green OK on the LCD monitor. (Refer to Fig.3-4)

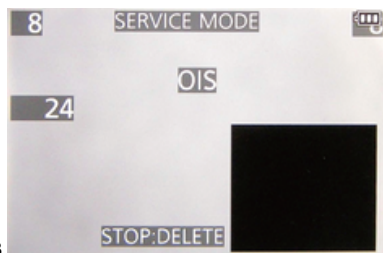

Fig.3-3

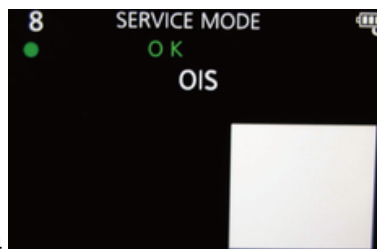

Fig.3-4

#### 10.3.1.4 Attention point during Adjustment

1. Step "10.3.1.3." procedure shows OIS adjustment as an example. To perform the adjustment, refer to the "10.3.2. Adjustment Specifications" table which shows key point for each adjustment.
2. Do not move the light box, the camera or the chart while adjusting. If one of these is moved accidentally, start the adjustment again.
3. Do not press any buttons/keys until the default menu (Refer to Fig.3-5) is displayed on the LCD monitor. Otherwise, adjustment data may not be stored properly.
4. If the adjustment is interrupted accidentally, the alignment data may not be properly saved in the Flash-ROM.

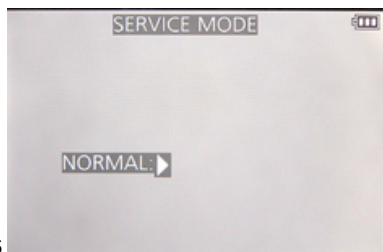

Fig.3-5

#### 10.3.1.5 Finalizing the Adjustment

1. Several adjustment flags can be reset ("F" into "0") at the same time. In this case, when the adjustment has been completed, the screen will change showing the adjustment for the next item until all reset items are completed.  
Also, when the [ Shutter ] button is pressed, the screen jump to the next adjusted item.
2. To cancel the adjustment mode while in the process of performing the adjustment, follow this procedures.
3. Operate the following, when escaping the Electrical Adjustment mode on the way.
  - (1) Press "[ DISP. ] button".
  - (2) Press "[ RIGHT ] of Cursor buttons".

**NOTE:**

- If adjustment is cancelled with above procedure, adjustment is not completed. Make sure to adjust it later.

#### 10.3.2 Adjustment Specifications

The following matrix table shows the relation between the replaced part and the Necessary Adjustment.

When a part is replaced, make sure to perform the necessary adjustment(s) in the order indicated.

The table below shows all the information necessary to perform each adjustment.

Adjustment Item	FLAG	Purpose	Replacing Parts							JIG/TOOLS	SETUP	How to Operate
			MAIN P.C.B. / VENUS ENGINE	MAIN P.C.B. (When written the Backup data)	Lens part (Excluding Image Sensor)	Image Sensor	Microphone	Flash Part	Rear Case Unit			
Optical Tilt	-	Adjustment of MOS Unit installation angle to the Lens			○	○						NOTE: It is necessary to use the "DSC_Tilt" software to allow the "Optical tilt adjustment". The Adjustment software "DSC_Tilt" is available at "TSN Website". • Optical Tilt Adjustment Driver RFKZ0569 : T4  • Optical Tilt Adjustment Chart RFKZ0570  • Camera Stand RFKZ033J  • Torque Driver RFKZ0542 * Tightening torques : 10N·cm ± 1 N·cm  • All adjusting screws need adjustment. (Fixed screw need loosening after tightening.) • Back angle (Default): 360 degrees • The screw locking glue is unnecessary, after adjustment.
Zoom Home Position	ZHP	Zoom Home Position Adjustment	○	-	○	○	-	-	-	NONE	NONE	1) Change the flag into the "0", and then proceed to the adjustment mode. 2) Press the shutter button fully. (When a result is OK, it is the completion of an inspection.)
Venus Zoom*4	PZM	Venus Zoom Inspection	○	○	-	-	-	-	-	NONE	NONE	1) Change the flag into the "0", and then proceed to the adjustment mode. 2) Press the shutter button fully. (When a result is OK, it is the completion of an inspection.)
OIS sensor	OIS	OIS sensor output level adjustment	○	-	○	○	-	-	-	NONE	NONE	1) Change the flag into the "0", and then proceed to the adjustment mode. 2) Press the shutter button fully. (When a result is OK, it is the completion of an inspection.)
Iris	IRS	Iris adjustment	○	-	-	○	-	-	-			
ND Filter	NDC	ND Filter Inspection	○	-	○	○	-	-	-			1) Set the camera in front of light box so that the distance between diffusing surface of light box and lens tube top becomes 0.0 cm (closest). (See "About adjust distance in adjustment procedures" for detail.)  • Light Box RFKZ0523
Shutter	SHTc	Shutter speed adjustment	○	-	○	○	-	-	-			1) Change the flag into the "0", and then proceed to the adjustment mode. 2) Set the camera angle so that the diffusing surface of light box is displayed on the full of LCD monitor, and press the shutter button fully. (When a result is OK, it is the completion of an inspection.)
Incident angle dependence WB adjustment	IAD	Incident angle dependence WB adjustment	○	-	○	○	-	-	-			

• Set "STEPMODE" to adjust ISO, WBL, WBM.  
 < How to switch to "STEPMODE" >  
 1) Perform "10.2.2. Flash-ROM Data Backup", and select "WBADJ → STEPMODE" for ROM\_BACKUP.  
 2) Press "SET", and mode to flag setting screen at "STEPMODE".  
 ⇒ The screen appears on the LCD. (See Fig. on the right.)

Normal FLAG setting screen

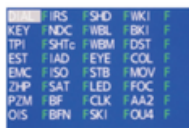

FLAG setting screen in STEPMODE

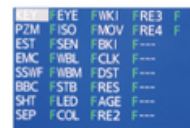

Adjustment Item	FLAG	Purpose	Replacing Parts							JIG/TOOLS	SETUP	How to Operate	
			MAIN P.C.B. / VENUS ENGINE	MAIN P.C.B. (When written the Backup data)	Lens part (Excluding Image Sensor)	Image Sensor	Microphone	FLash Part	Rear Case Unit				Electronic Level (IC6201)
ISO	ISO	ISO sensitivity adjustment	○	-	○	○	-	-	-	-	<ul style="list-style-type: none"> <li>• Light Box RFKZ0523</li> <li>• ND0.3 Filter RFKZ0513</li> </ul>	1) Set the filter to the diffusing surface of light box. 2) Set the camera in front of light box so that the distance between diffusing surface of light box and lens tube top becomes <b>0.0 cm</b> (closest). (See "About adjust distance in adjustment procedures" for detail.)	1) Change the flag into the "0", and then proceed to the adjustment mode. 2) Set the camera angle so that the diffusing surface of light box is displayed on the full of LCD monitor, and press the shutter button fully. (When adjustment is started, the lens tube is not extended.)  (When a result is OK, it is the completion of an inspection.)
White balance (Low color temp.)	WBL	Setting up the white in low color temperature	○	-	○	○	-	-	-	<ul style="list-style-type: none"> <li>• Light Box RFKZ0523</li> <li>• ND0.9 Filter VFK1164ND09</li> <li>• ND0.3 Filter RFKZ0513</li> <li>• CC-C7.5 Filter RFKZ0511</li> </ul>			
White balance (High color temp.)	WBM	Setting up the white in high color temperature	○	-	○	○	-	-	-	<ul style="list-style-type: none"> <li>• Light Box RFKZ0523</li> <li>• ND0.9 Filter VFK1164ND09</li> <li>• ND0.3 Filter RFKZ0513</li> <li>• CC-C7.5 Filter RFKZ0511</li> <li>• CC-Y10 Filter RFKZ0512</li> <li>• LBB2 Filter RFKZ0520</li> <li>• LBB8 Filter RFKZ0521</li> </ul>			
<ul style="list-style-type: none"> <li>• After adjusting ISO, WBL, WBM, perform Initial Settings once.</li> <li>Then, cancel "STEPMODE".</li> <li>&lt; How to release of "STEPMODE" &gt;</li> <li>• Perform "10.2.2. Flash-ROM Data Backup", and select "STEPMODE → WBADJ" for ROM_BACKUP. Press "SET".</li> <li>Then again, cancel the Initial Settings.</li> <li>Move to servicing mode, and continue the subsequent adjustment.</li> </ul>													
Offset gain	SAT	Setting up the offset gain.	○	-	○	○	-	-	-	-	<ul style="list-style-type: none"> <li>• Light Box RFKZ0523</li> <li>• ND0.6 Filter VFK1164ND06</li> </ul>	1) Set the filter to the diffusing surface of light box. 2) Set the camera in front of light box so that the distance between diffusing surface of light box and lens tube top becomes <b>0.0 cm</b> (closest). (See "About adjust distance in adjustment procedures" for detail.)	1) Change the flag into the "0", and then proceed to the adjustment mode. 2) Set the camera angle so that the diffusing surface of light box is displayed on the full of LCD monitor, and press the shutter button fully. (When adjustment is started, the lens tube is extended.)  (When a result is OK, it is the completion of an inspection.)
Backfocus / GYRO*4	BF	To have the focus tracking curve be appropriate shape and GYRO sensor adjustment	○	○	○	○	*1	-	-	-	<ul style="list-style-type: none"> <li>• Collimator RFKZ0422</li> </ul>	1) Set the camera in front of light box so that the distance between diffusing surface of light box and lens tube top becomes <b>0.0 cm</b> (closest). (See "About adjust distance in adjustment procedures" for detail.) • Set the camera on a tripod to	1) Change the flag into the "0", and then proceed to the adjustment mode. 2) Set the camera angle so that the star chart is displayed to the center, and press the shutter button fully. (Zooming starts from Wide-End to Tele-End, then green ● mark is displayed on LCD and paused.) 3) Press the shutter button fully again.



Adjustment Item	FLAG	Purpose	Replacing Parts								JIG/TOOLS	SETUP	How to Operate	
			MAIN P.C.B. / VENUS ENGINE	MAIN P.C.B. (When written the Backup data)	Lens part (Excluding Image Sensor)	Image Sensor	Microphone	Flash Part	Rear Case Unit	Electronic Level (IC6201)				
Backfocus (Finite distance) Adjustment	BFN	Backfocus (Finite distance) Adjustment	○	-	○	○	-	-	-	-	-	• BFN Chart	<ol style="list-style-type: none"> <li>1) Download the "FZ-BFN-00.pdf" and print it to A3 size (or equivalent size) paper. ("FZ-BFN-00.pdf" is available at "TSN Website". To download, click on "Support Information from NWBG/DBG-AVC".)</li> <li>2) Put the chart on center of the wall. (the wall is not high contrast, and 400mm (height) and 550mm (width).)</li> <li>3) Set the camera in front of the chart so that the distance between chart and lens tube top becomes <math>100 \pm 0.3\text{cm}</math>. (See "About adjust distance in adjustment procedures" for detail.)</li> </ol>	<ol style="list-style-type: none"> <li>1) Change the flag into the "0", and then proceed to the adjustment mode.</li> <li>2) Set the camera angle so that the star chart is displayed to the center, and press the shutter button fully. (When a result is OK, it is the completion of an inspection.)</li> </ol>
	SHD	Do not use "SHD" adjustment flag for this unit. Use "BK2" adjustment flag, instead.												
Eye sensor	EYE	Inspecting sensitivity of eye sensor	○	-	-	-	-	-	○	-	-	• Gray Card RFKZ0506	<ol style="list-style-type: none"> <li>1) Set the camera in front of gray card so that the distance between gray card and eye sensor of camera body becomes <math>4.5\text{ cm}</math>.</li> </ol>	<ol style="list-style-type: none"> <li>1) Change the flag into the "0", and then proceed to the adjustment mode.</li> <li>2) Set the camera so that the attachment side of eye sensor and center of the gray card is perpendicular, and press the shutter button fully. (When a result is OK, it is the completion of an inspection.)</li> </ol>
Flash Adjustment *4	STB	Flash Adjustment	○	○	-	-	-	○	-	-	NONE	NONE	<ol style="list-style-type: none"> <li>1) Change the flag into the "0", and then proceed to the adjustment mode.</li> <li>2) Slide the Flash Open Lever, and open the Flash.</li> <li>3) Press the shutter button fully.</li> <li>4) Check that a flash shines and AF assist lamp lights. (It is different for every model how many times it shines.) <ul style="list-style-type: none"> <li>• When a flash does not shine, there is a possibility that the flash unit is out of order.</li> </ul> </li> <li>5) Check a test result. <ul style="list-style-type: none"> <li>• Results of the tests are usually NG. (When a result is OK, it is the completion of an inspection.)</li> </ul> </li> <li>6) When a result is NG, rewrite STB flag to an adjustment using <b>ADJFLG → ALL F of ROM BACKUP</b>. <ul style="list-style-type: none"> <li>• The flag "STB" is an item which checks shines operation of a flash automatically at a Manufacturing facility. For this reason, except environment for exclusive use, a result will be NG, but it is no problem if shines operation can be checked visually.</li> </ul> </li> </ol>	
MOS sensor Temp. white missing pixels *2	SKI	Registration of the Temp. white missing pixels	○	-	○	○	-	-	-	-	NONE	NONE	<ol style="list-style-type: none"> <li>1) Change the flag into the "0", and then proceed to the adjustment mode.</li> <li>2) Press the shutter button fully. (When a result is OK, it is the completion of an inspection.)</li> </ol>	
MOS sensor FD white missing pixels *2	WKI	Registration of the FD (floating diffusion) white missing pixels	○	-	○	○	*1	-	-	-	NONE	NONE	<ol style="list-style-type: none"> <li>1) Change the flag into the "0", and then proceed to the adjustment mode.</li> <li>2) Press the shutter button fully. (When a result is OK, it is the completion of an inspection.)</li> </ol>	
	BKI	Do not use "BK1" adjustment flag for this unit. Use "BK2" adjustment flag, instead. (In case of most DSC models, the adjustment flag for MOS SENSOR Missing Pixels is "BK1". But, in this model, "BK2" the adjustment flag for MOS SENSOR Missing Pixels.)												
													<ol style="list-style-type: none"> <li>1) Change the flag into the "0", and then proceed to the adjustment mode.</li> <li>2) Press the shutter button fully. Utter the voice for about 5 seconds into the</li> </ol>	

Adjustment Item	FLAG	Purpose	Replacing Parts							JIG/TOOLS	SETUP	How to Operate
			MAIN P.C.B. / VENUS ENGINE	MAIN P.C.B. (When written the Backup data)	Lens part (Excluding Image Sensor)	Image Sensor	Microphone	Flash Part	Rear Case Unit			
Shading Compensation and MOS SENSOR Missing Pixels (Black) *3	BK2	Compensation of Shading and Compensation of MOS SENSOR Missing Pixels (Black)	○	-	○	○	*1	-	-	-	-	<p>&lt; Setup &gt;</p> <ol style="list-style-type: none"> <li>1) Attach the gray chart to a flat wall and set so that the entire surface is irradiated with illumination light.                             <ul style="list-style-type: none"> <li>* The light source should always be a single light source. (Be careful not to mix other lights)</li> <li>* There is no problem with the brightness of normal room lighting degree.</li> </ul> </li> <li>2) Turn the camera to the chart and check that the entire screen is almost uniform brightness.</li> </ol> <div style="text-align: center;"> <p>Gray chart RFKZ0612</p> </div> <ul style="list-style-type: none"> <li>* Gray Chart RFKZ0612</li> <li>* The room that is lit halogen bulb or inverter fluorescent lamp.</li> </ul> <p>&lt; How to operate &gt;</p> <ol style="list-style-type: none"> <li>1) Change the flag into the "0", and then proceed to the adjustment mode. (BK2 flag is 2nd pages.)</li> <li>2) Press the shutter button fully. → Green ● mark is displayed on LCD.</li> <li>3) Turn the camera to the chart. And set the camera angle so that the chart surface is displayed on the full of LCD monitor, and press the shutter button fully. → The 1st adjustment is executed, and then green ● mark is displayed on LCD.</li> <li>4) press the shutter button fully, again. → The lens starts zooming and stops automatically, then green ● mark is displayed on LCD.</li> <li>5) Turn the camera to the chart. And set the camera angle so that the chart surface is displayed on the full of LCD monitor, and press the shutter button fully. → The 2nd adjustment is executed, and then green ● mark is displayed on LCD.</li> <li>6) press the shutter button fully, again. → The lens starts zooming and stops automatically, then green ● mark is displayed on LCD.</li> <li>7) Turn the camera to the chart. And set the camera angle so that the chart surface is displayed on the full of LCD monitor, and press the shutter button fully. → The 3rd adjustment is executed, and then green ● mark is displayed on LCD.</li> <li>8) As it is (keeping the chart surface on the full of LCD monitor), press the shutter button fully, again. → When a result is OK, it is the completion of an inspection.</li> </ol>
Electronic Level	AA2 + AA3	Electronic Level adjustment	○	○	-	-	-	-	-	○	<ul style="list-style-type: none"> <li>* ACC Adjustment Chart</li> </ul> <ol style="list-style-type: none"> <li>1) Download the "ACC Adjustment chart.pdf" and print it to A3 size (or equivalent size) paper. ("ACC Adjustment chart.pdf" is available at "TSN Website". To download, click on "Support Information from NDBG/VDBG-AVC".)</li> <li>2) Hang in the string with weight, then put the printed ACC adjustment chart on the wall or panel horizontally. (Fig. A)                             <ul style="list-style-type: none"> <li>* After putting the adjustment chart horizontally, remove the string with weight.</li> <li>* Attach the camera to tripod.</li> </ul> </li> </ol> <p>&lt;Setup procedures&gt;</p> <ol style="list-style-type: none"> <li>3-1) Adjust the height of tripod to match the lens of camera and center of the adjustment chart.</li> <li>3-2) Apply the triangle (or equivalent) in center of the chart, then adjust center of the lens of camera on the vertical extension.</li> </ol> <p>&lt;Offset adjustment&gt;</p> <ol style="list-style-type: none"> <li>2) Set the camera to the horizontal position. Then set the distance between adjustment chart and lens tube top becomes 25 cm. And optical axis of the lens and center of the chart crosses right-angled. (Fig. C) (See "About adjust distance in adjustment procedures" for detail.)</li> <li>3) Press the shutter button fully. (When a result is OK, it is the completion of an inspection.)</li> </ol> <p>&lt;Tilt adjustment&gt;</p> <ol style="list-style-type: none"> <li>4) Rotate the camera to the 90 degrees, so that the grip side down, and press the shutter button. (Fig. D)</li> <li>5) Set the camera to the horizontal position, and press the shutter button. (Fig. E)</li> <li>6) Rotate the camera to the 90 degrees, so</li> </ol>	

Adjustment Item	FLAG	Purpose	Replacing Parts						JIG/TOOLS	SETUP	How to Operate
			MAIN P.C.B. / VENUS ENGINE	MAIN P.C.B. (When written the Backup data)	Lens part (Excluding Image Sensor)	Image Sensor	Microphone	Flash Part			

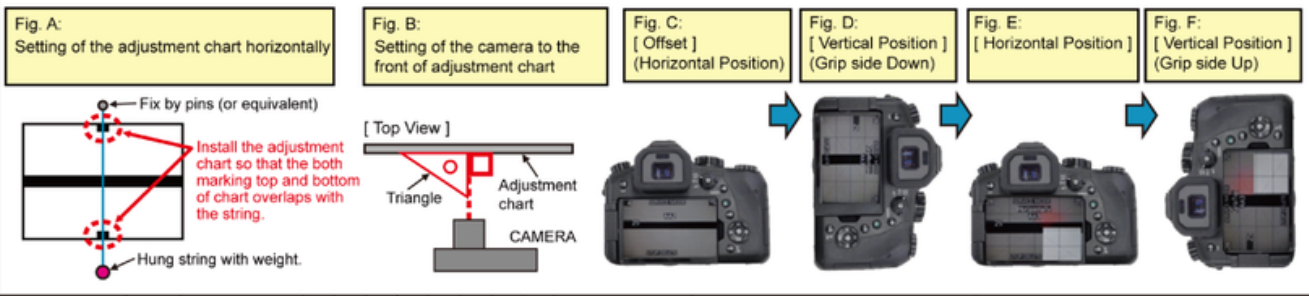

OLN Linerity	OLN	Compensation of Shading and Compensation of MOS SENSOR Missing Pixels (Black)	○	-	○	*1	-	-	-	-	* OLN Chart	<ol style="list-style-type: none"> <li>1) Download the "C-OLN_Chart_FZ-02.pdf" and print it "Actual size". ("C-OLN_Chart_FZ-02.pdf" is available at "TSN Website". To download, click on "Support Information from NWBG/VDBG-AVC".) <ul style="list-style-type: none"> <li>• Printing must perform with "Actual size". Not "Printing according to paper size".</li> <li>• Confirm that the length of the black belt long side is <b>83 mm</b> (82.994 mm).</li> </ul> </li> <li>2) Put the OLN chart on the wall.</li> <li>3) Attach the camera to tripod. Set the camera in front of the chart so that the distance between chart and lens tube top becomes <b>1.9m</b>. <ul style="list-style-type: none"> <li>• It is distance between lens tube top and the chart. See "About adjust distance in adjustment procedures" for detail.</li> </ul> </li> <li>4) Zoom up to Tele-End, and fine adjust the camera angle so that the chart becomes to display center of the LCD monitor.</li> </ol>	<ol style="list-style-type: none"> <li>1) Change the flag into the "0", and then proceed to the adjustment mode.</li> <li>2) Press the shutter button fully, and the camera is zooming up automatically. <ul style="list-style-type: none"> <li>• At this time, confirm that the center mark of the chart matches the center of the angle of view adjustment guide frame (white frame) displayed on the LCD.</li> </ul> </li> </ol> <p>(When a result is OK, it is the completion of an inspection.)</p>
--------------	-----	---	---	---	---	----	---	---	---	---	-------------	--	--

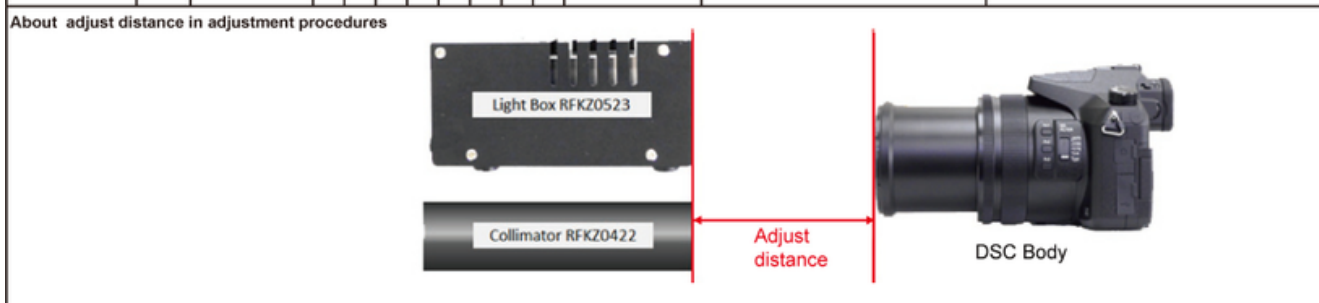

Wi-Fi check	WiFi	Do not use "WiFi" adjustment flag for servicing. This adjustment is for factory procedure. (For confirmation of Wi-Fi function, use the reception level of Wi-Fi access point as usual.)
-------------	------	--

- \* 1: This adjustment must be performed not only replacing the MOS Unit, but also simply removing the MOS Unit.
- \* 2: The pixel that always lights while shaded is called a white wound.
- \* 3: The pixel that does not light while complete exposed is called a black wound.
- \* 4: If the adjusted data is backed up from the main board before replacement or repair, write the data to the new main board. If parts other than the main board are not replaced, adjustment is not necessary for items other than "Venus Zoom(PZM) / Backfocus / GYRO(BF) / Flash(STB)".

\* This unit does not have the LCD adjustment of the camera (LCD flicker adjustment etc.).



## 10.4 After Adjustment

### 10.4.1 Initial Setting

Since the initial setting has been released to execute the built-in adjustment software, it should be set up again before shipping the camera to the customer.

Refer to the procedure described in "3.5.2. Initial Settings" for details.

**[ IMPORTANT ]**

1. The initial setting should be done again after completing the alignment. Otherwise, the camera will not work properly. Therefore as a warning, the camera display a warning symbol " !" on the LCD monitor every time the camera is turned off.
2. Confirm that status of all adjustment flag show "F". Even if one of the adjustment flag shows "0", initial setting programmed is never executed.

# 11 Maintenance

## 11.1 Cleaning Lens, Viewfinder and LCD Panel

Do not touch the surface of lens, Viewfinder and LCD Panel with your hand.

When cleaning the lens, use air-blower to blow off the dust.

When cleaning the LCD Panel, dampen the lens cleaning paper with lens cleaner, and the gently wipe the its surface.

**Note:**

The Lens Cleaning Kit ; VFK1900BK (Only supplied as 10 set/Box) is available as Service Aid.

---

**Model No. : DMC-FZ2000/FZ2500 Schematic Diagram Note**

---

**IMPORTANT SAFETY NOTICE:**

COMPONENTS IDENTIFIED WITH THE MARK  HAVE THE SPECIAL CHARACTERISTICS FOR SAFETY. WHEN REPLACING ANY OF THESE COMPONENTS USE ONLY THE SAME TYPE.

1. Although reference number of the parts is indicated on the P.C.B. drawing and/or schematic diagrams, it is NOT mounted on the P.C.B. when it is displayed with "\$" mark.
2. It is only the "Test Round" and no terminal (Pin) is available on the P.C.B. when the TP (Test Point) indicated as "●" mark.
3. Use the parts number indicated on the Replacement Parts List .
4. Indication on Schematic diagrams:

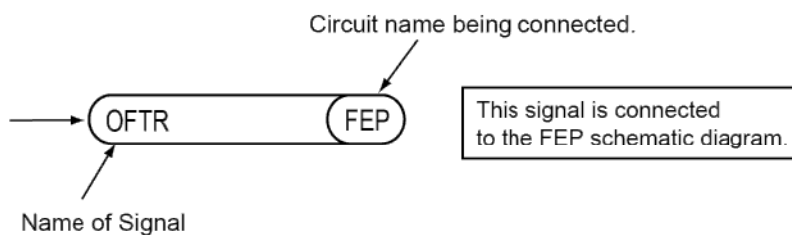

5. It might be taking time for display and/or access of the Schematic Diagrams & P. C. B. having the heavy data volume.

---

**Model No. : DMC-FZ2000/FZ2500 Parts List Note**

---

- Note:
1. \* Be sure to make your orders of replacement parts according to this list.
  2. **IMPORTANT SAFETY NOTICE**  
Components identified with the mark  $\triangle$  have the special characteristics for safety.  
When replacing any of these components, use only the same type.
  3. Unless otherwise specified,  
All resistors are in OHMS, K=1,000 OHMS. All capacitors are in MICRO-FARADS (uf), P=uuF.
  4. The marking (RTL) indicates the retention time is limited for this item. After the discontinuation of this assembly in production, it will no longer be available.
  5. Supply of CD-ROM or DVD, in accordance with license protection, is allowable as replacement parts only for customers who accidentally damaged or lost their own.

**E.S.D. standards for Electrostatically Sensitive Devices, refer to PREVENTION OF ELECTROSTATIC DISCHARGE (ESD) TO ELECTROSTATICALLY SENSITIVE (ES) DEVICES section.**

**Definition of Parts supplier:**

1. **Parts marked with [INBD] in the remarks column are supplied from AVC-IMAGING. Others are supplied from PAVCX.**

Model No. : DMC-FZ2000/FZ2500 Power (P) (Main P.C.B.)

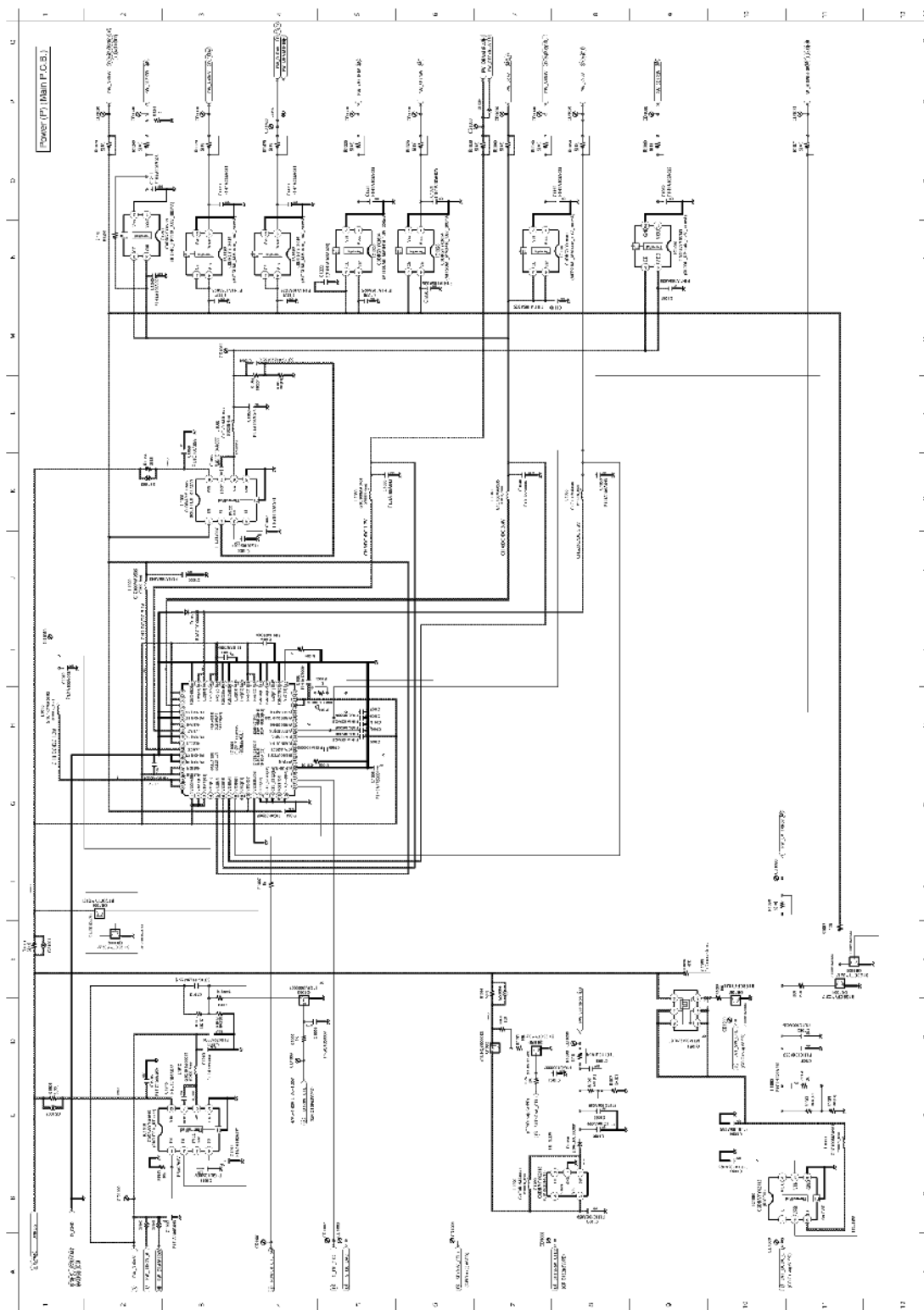

# Model No. : DMC-FZ2000/FZ2500 Jack (J) (Main P.C.B.)

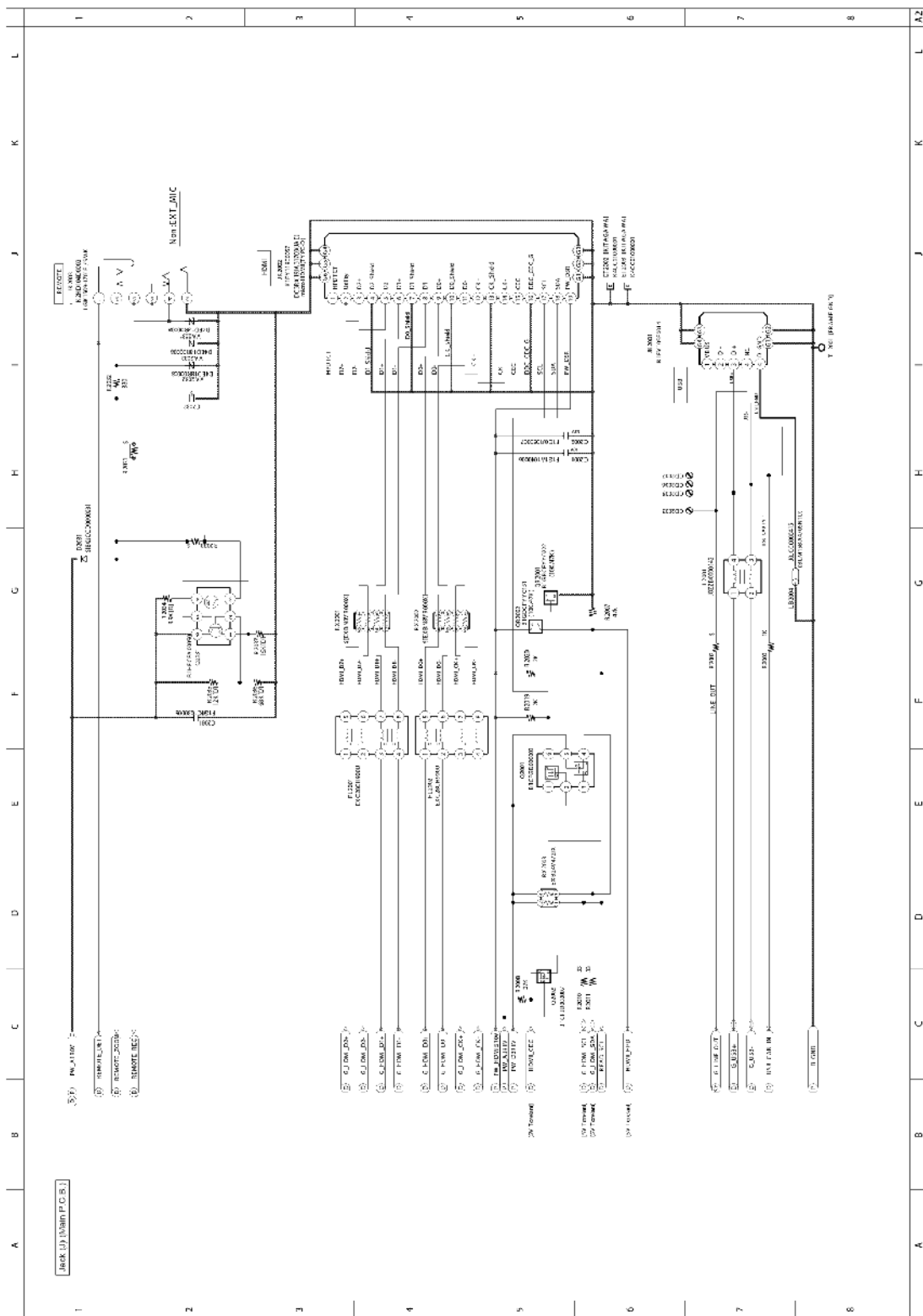

**Model No. : DMC-FZ2000/FZ2500 EXT MIC (EM) (Main P.C.B.)**

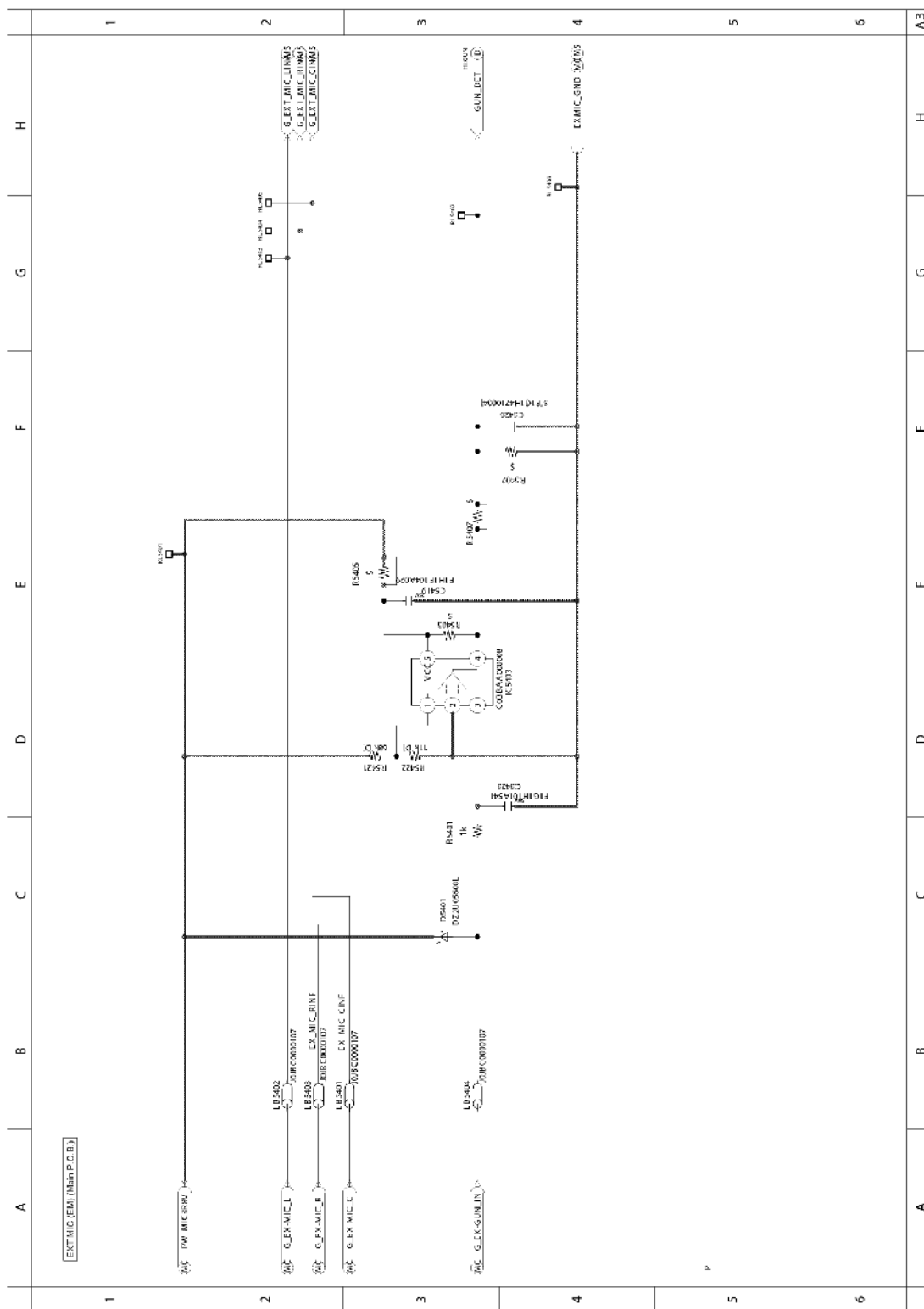

### Model No. : DMC-FZ2000/FZ2500 Headphone Amp (HP) (Main P.C.B.)

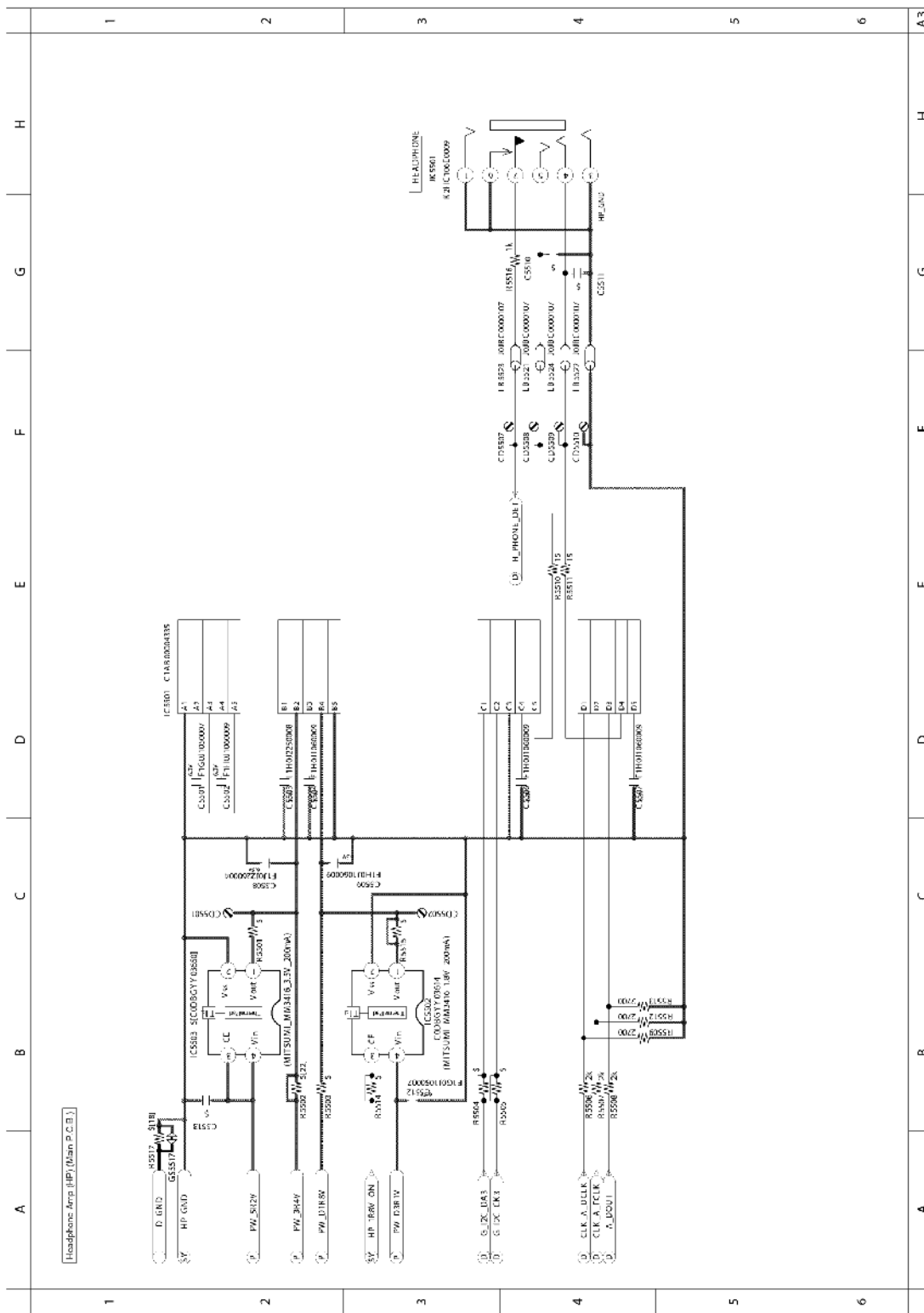



Model No. : DMC-FZ2000/FZ2500 Digital (D) (Main P.C.B.)

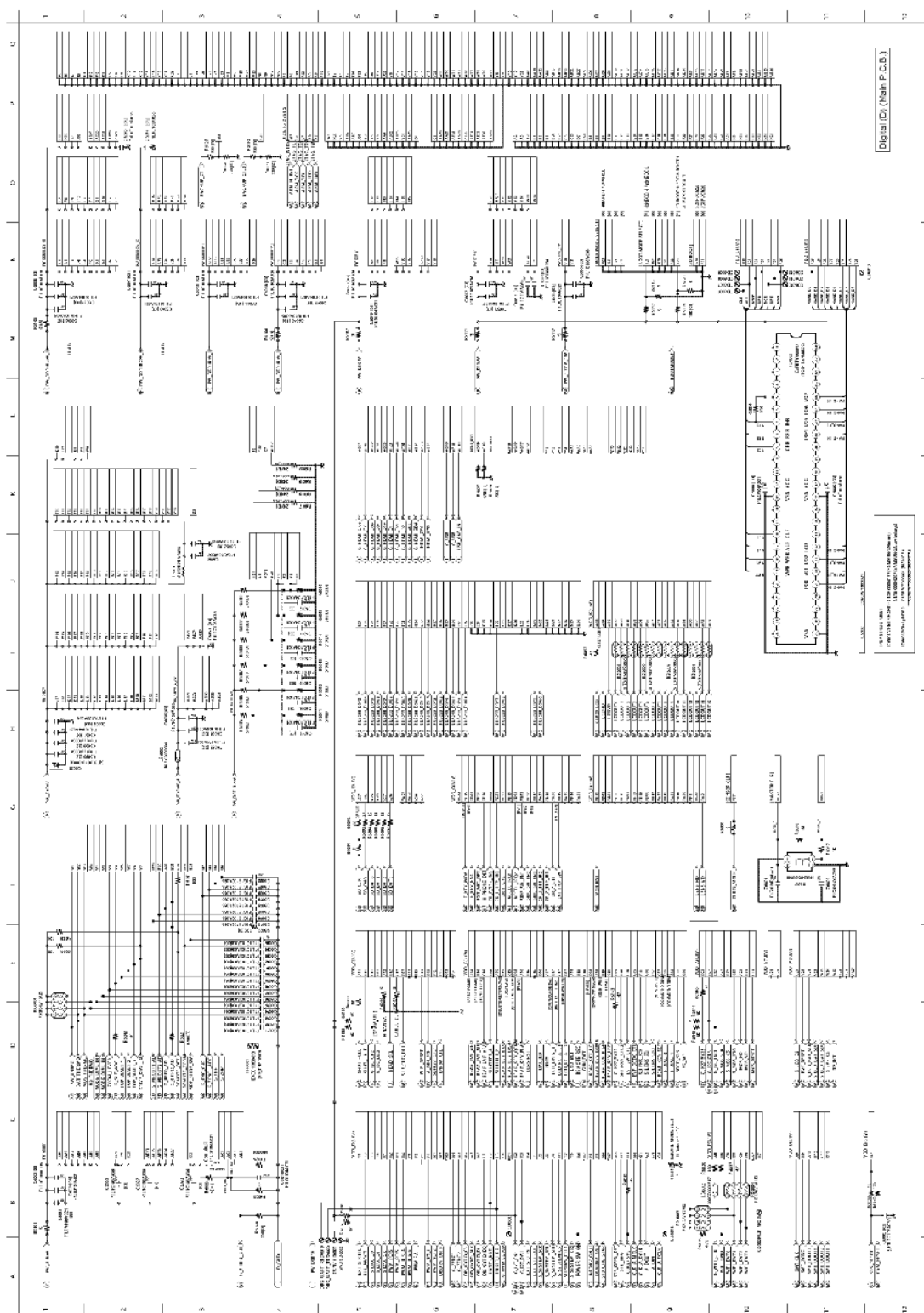

### Model No. : DMC-FZ2000/FZ2500 SD Card (SD) (Main P.C.B.)

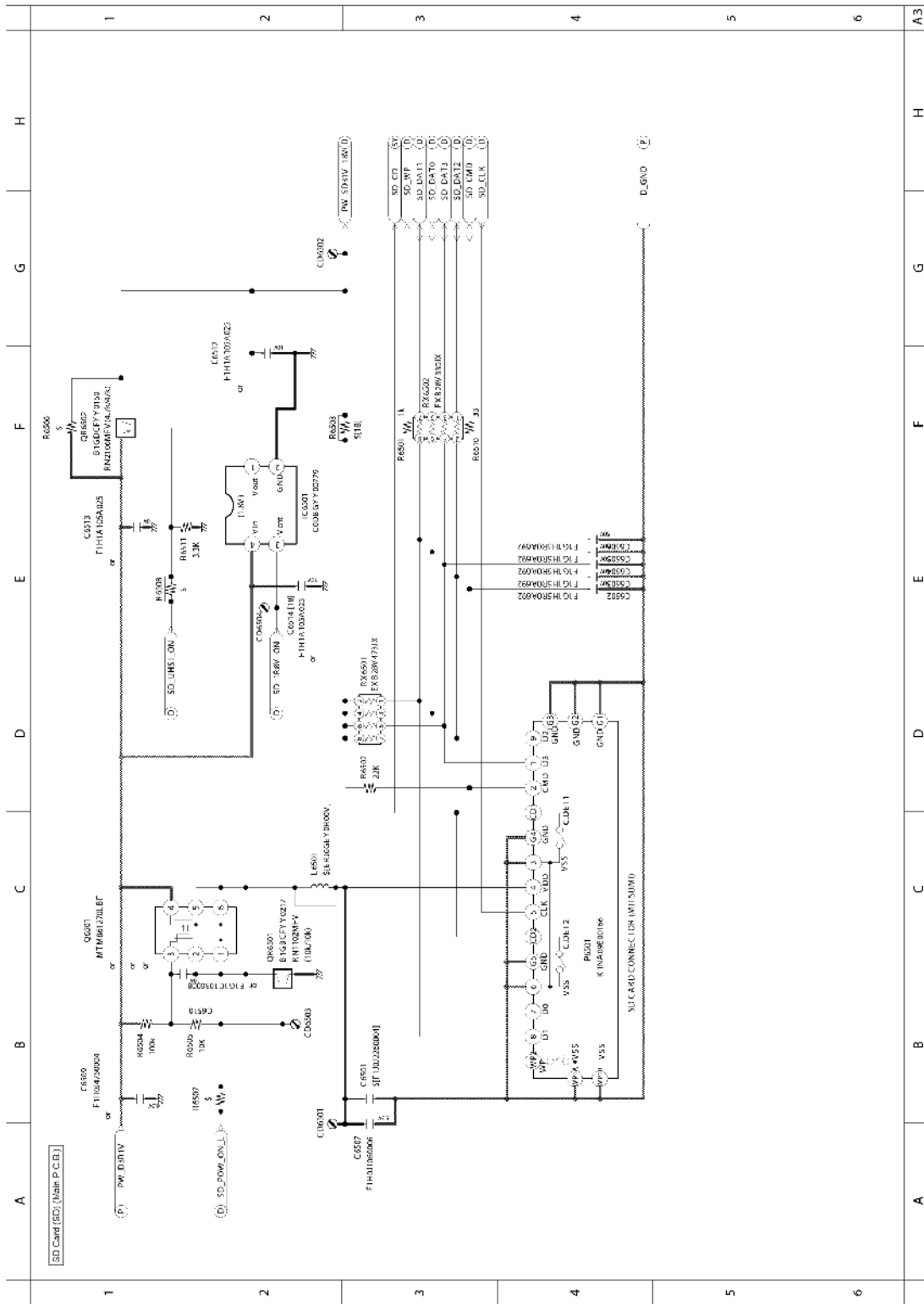

**Model No. : DMC-FZ2000/FZ2500 Acceleration (AC) (Main P.C.B.)**

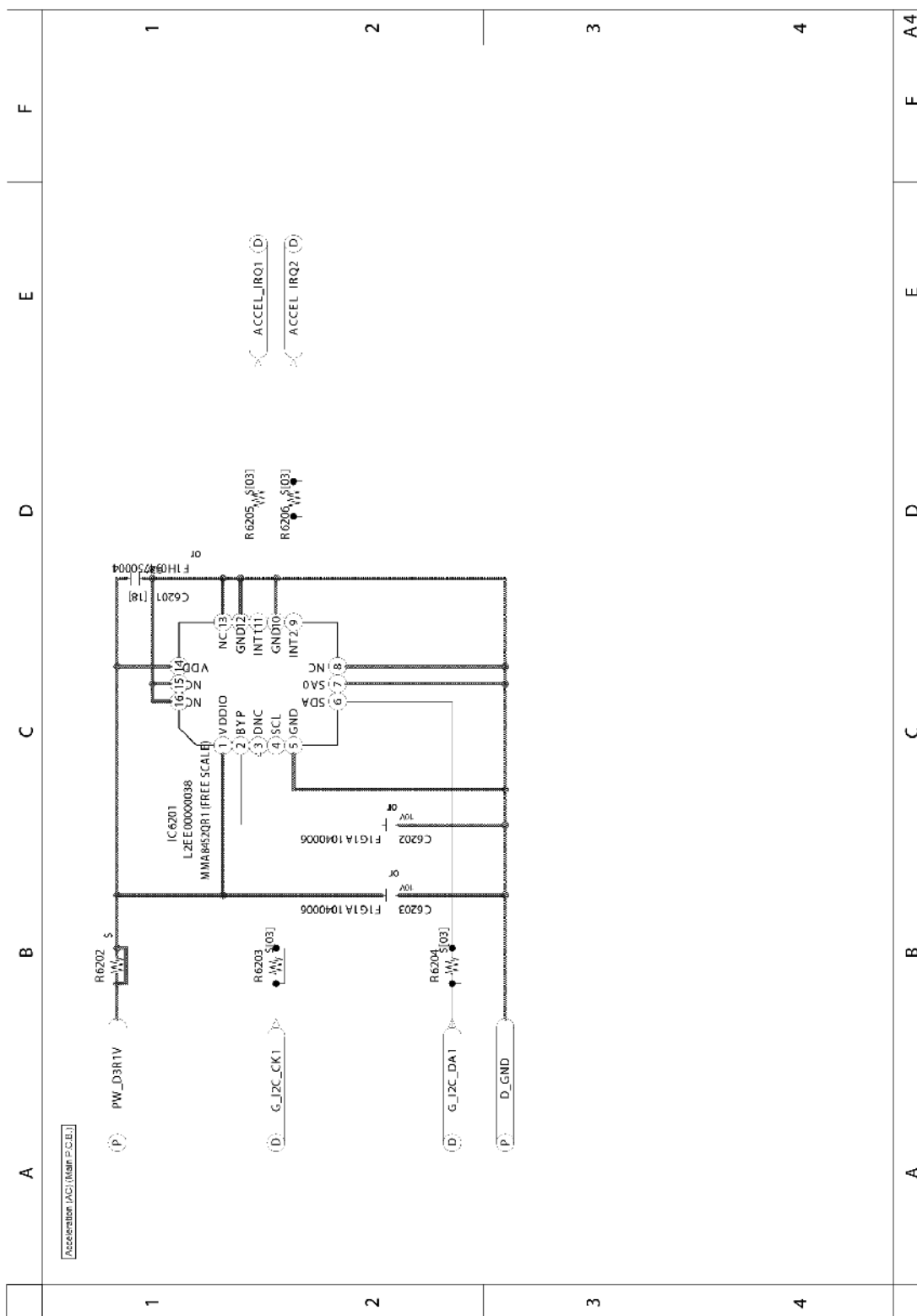

### Model No. : DMC-FZ2000/FZ2500 Hibernation (HI) (Main P.C.B.)

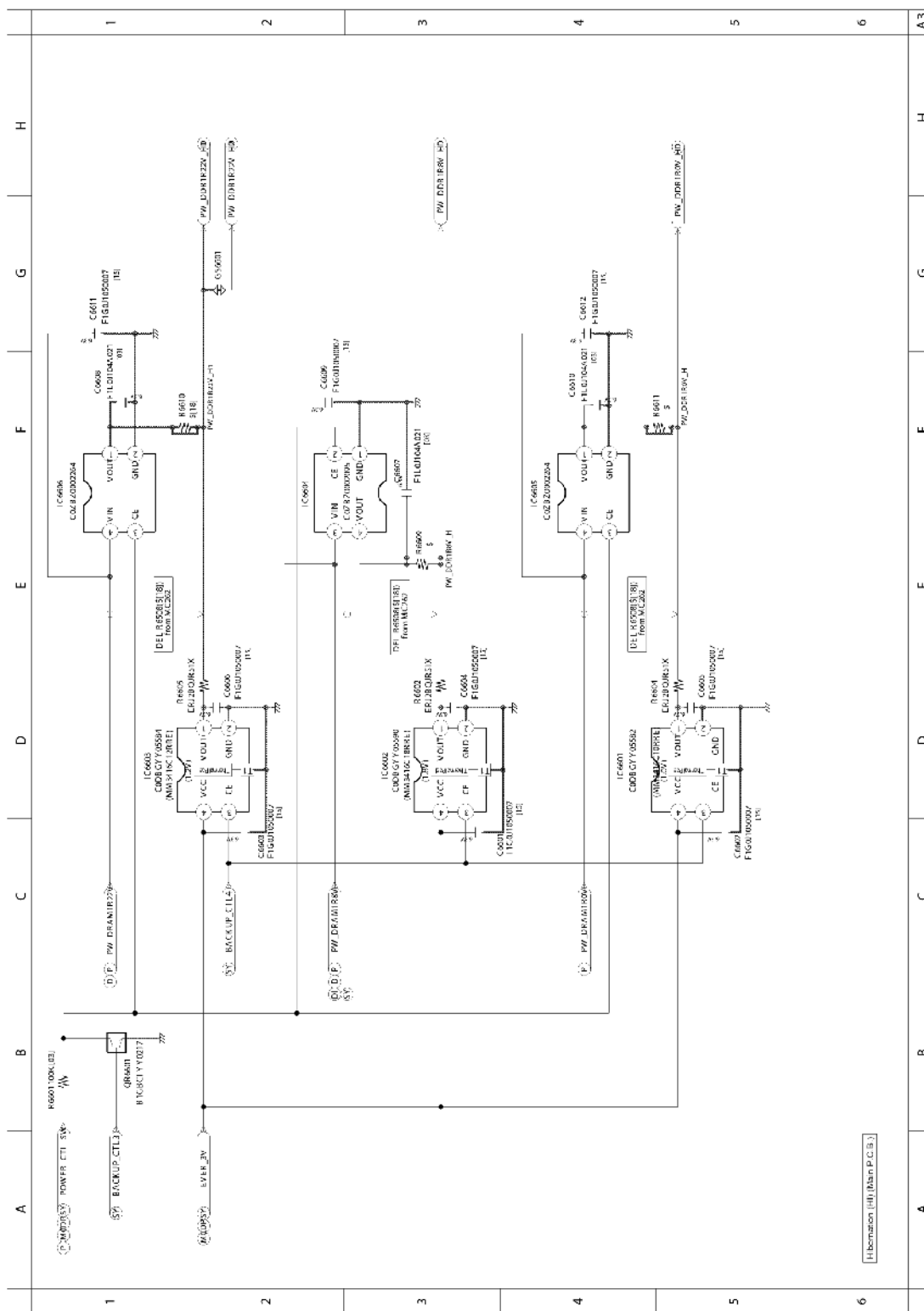

Model No. : DMC-FZ2000/FZ2500 Gyro (GY) (Main P.C.B.)

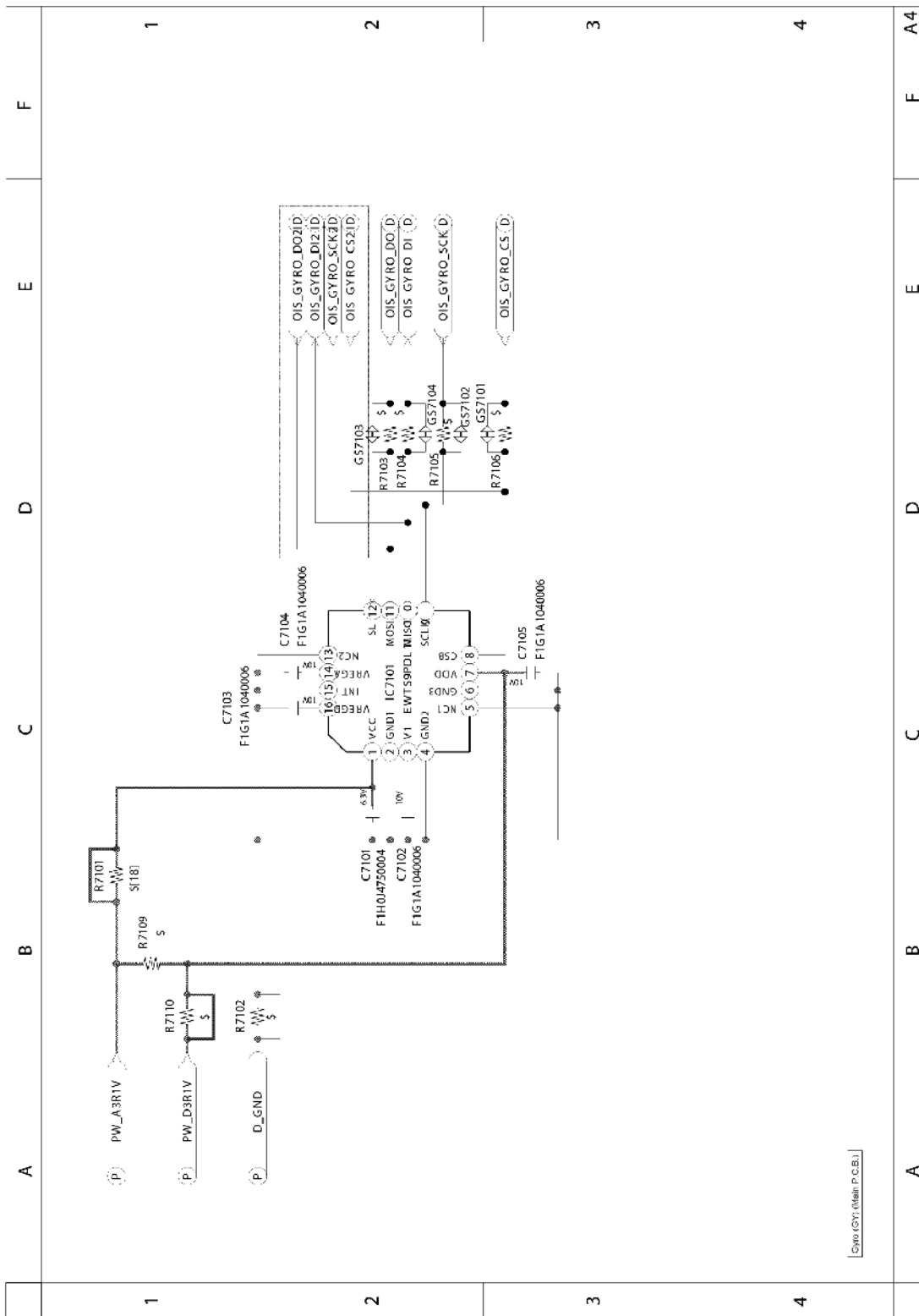

# Model No. : DMC-FZ2000/FZ2500 EX Driver (ED) (Main P.C.B.)

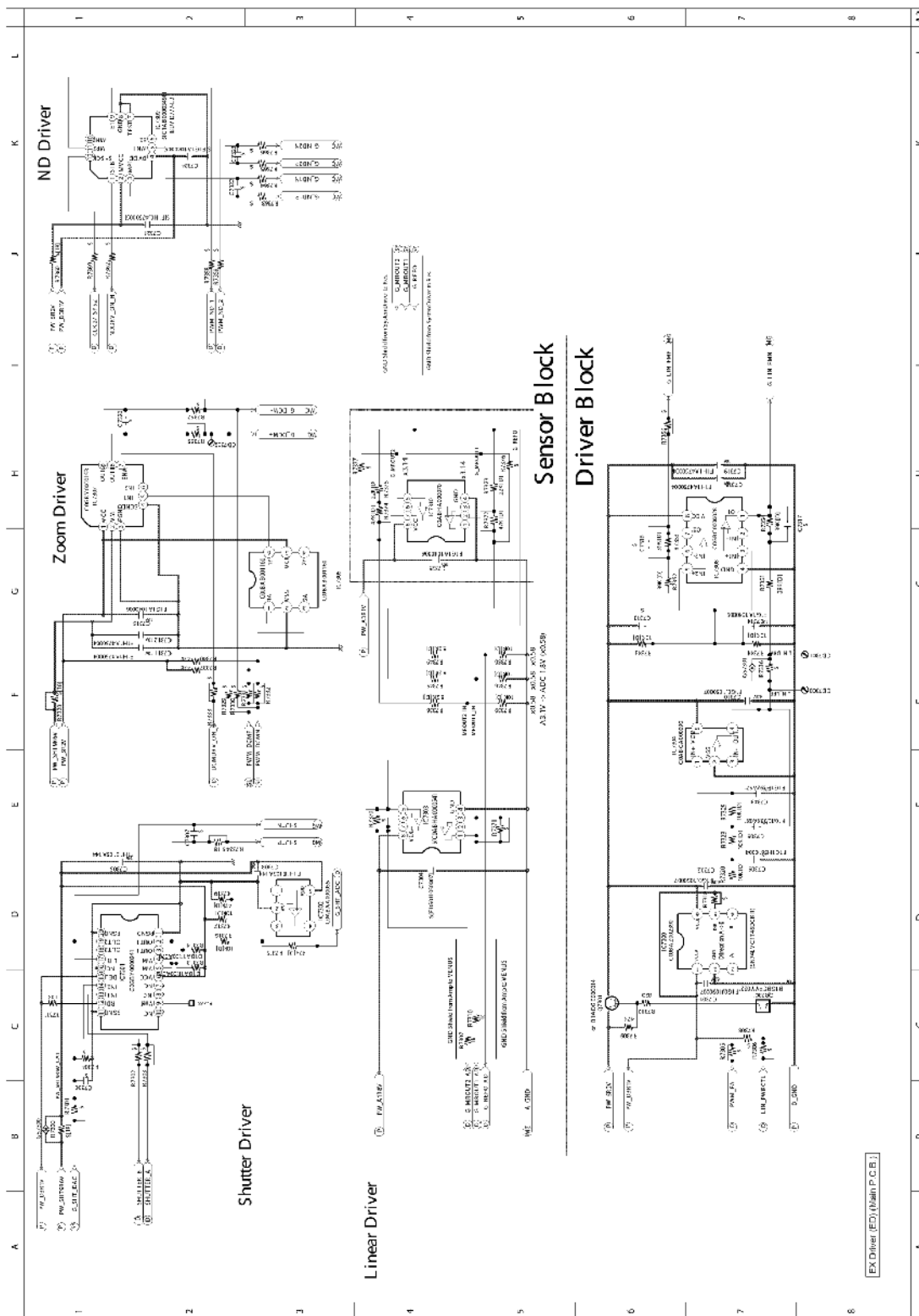

**Model No. : DMC-FZ2000/FZ2500 Hot Shoe (HS) (Main P.C.B.)**

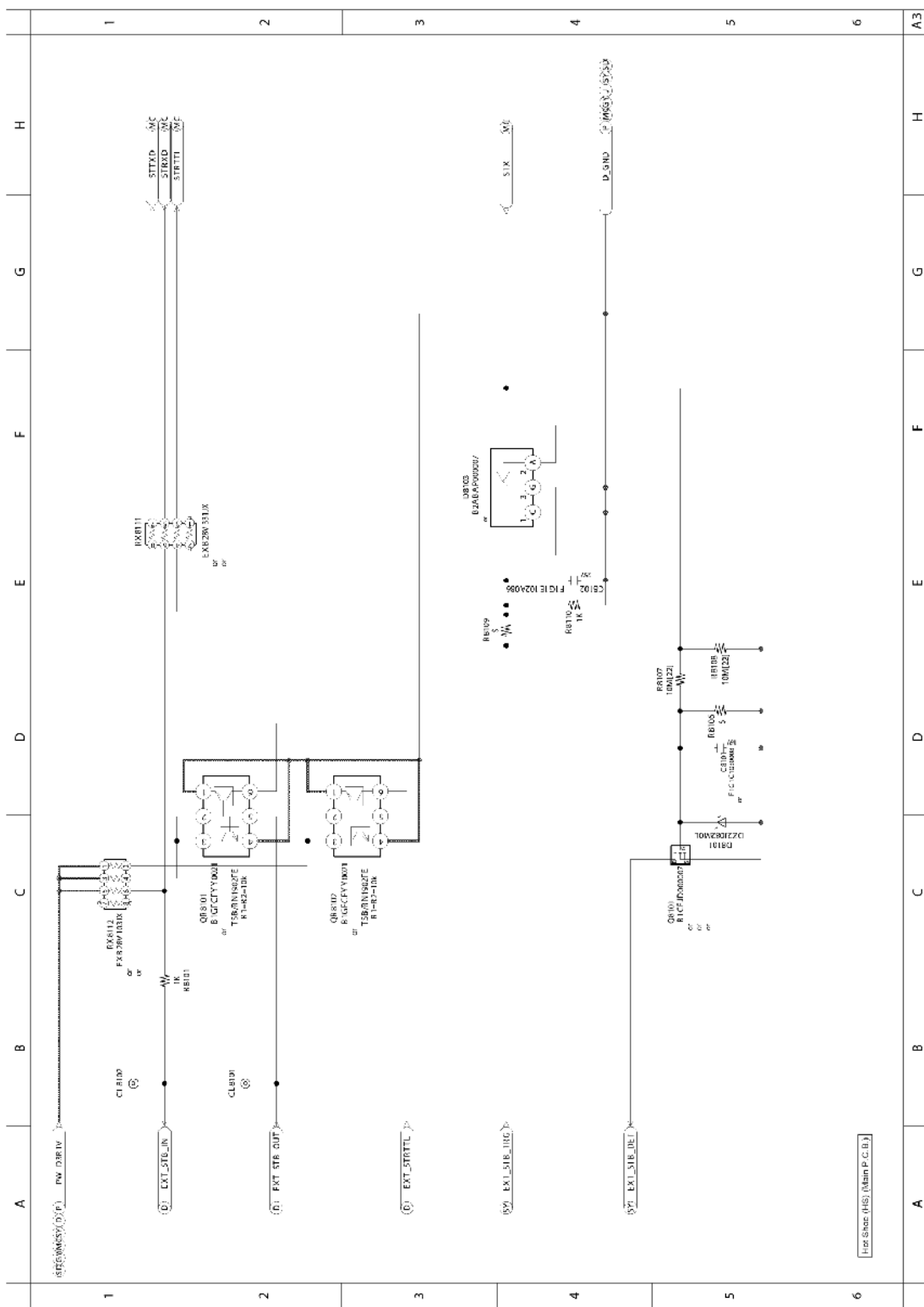

# Model No. : DMC-FZ2000/FZ2500 Main Connection (MC) (Main P.C.B.)

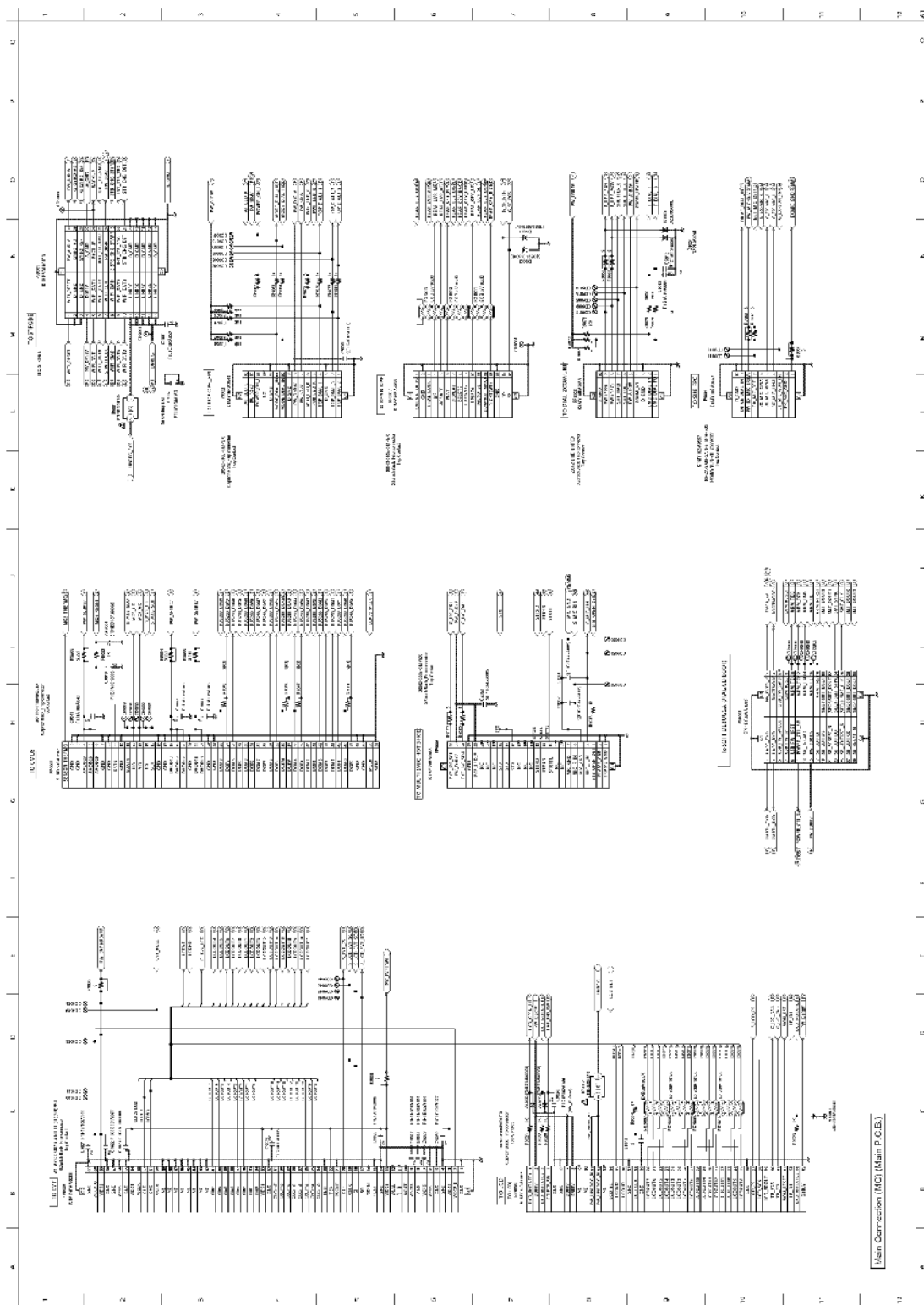



Model No. : DMC-FZ2000/FZ2500 System Lens Driver (SL) (Main P.C.B.)

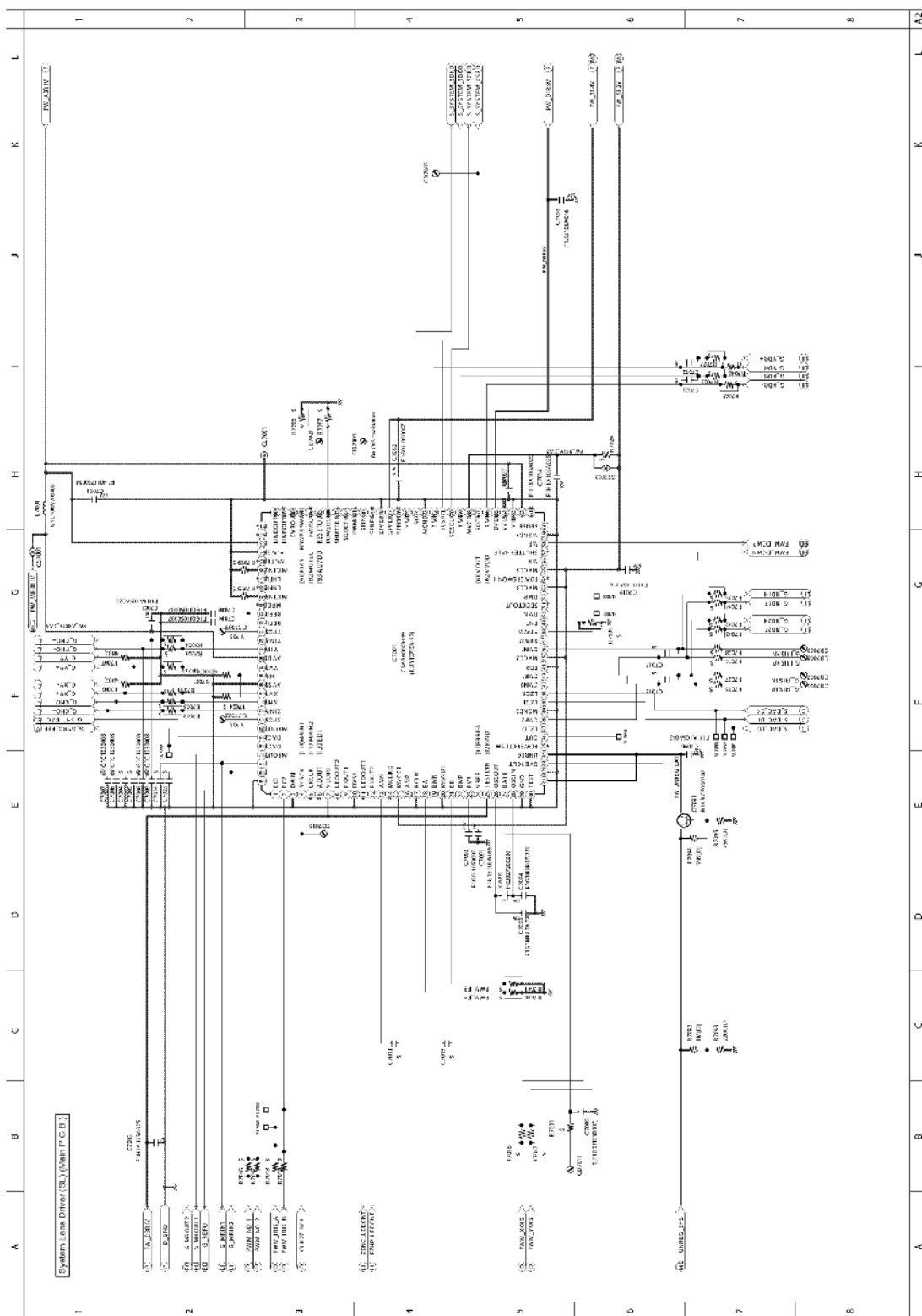

Model No. : DMC-FZ2000/FZ2500 Iris Driver (ID) (Main P.C.B.)

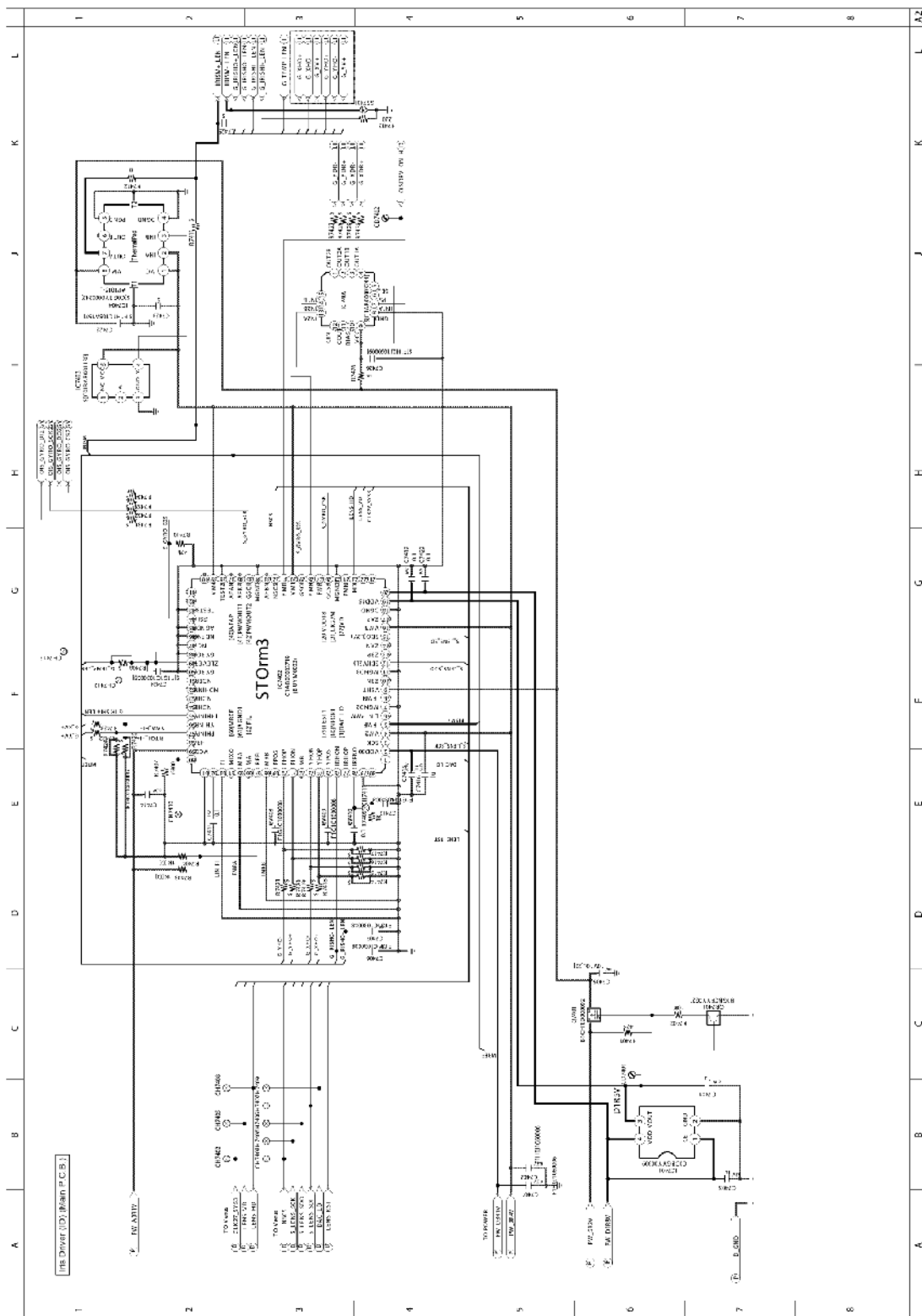

# Model No. : DMC-FZ2000/FZ2500 System Driver (SY) (Main P.C.B.)

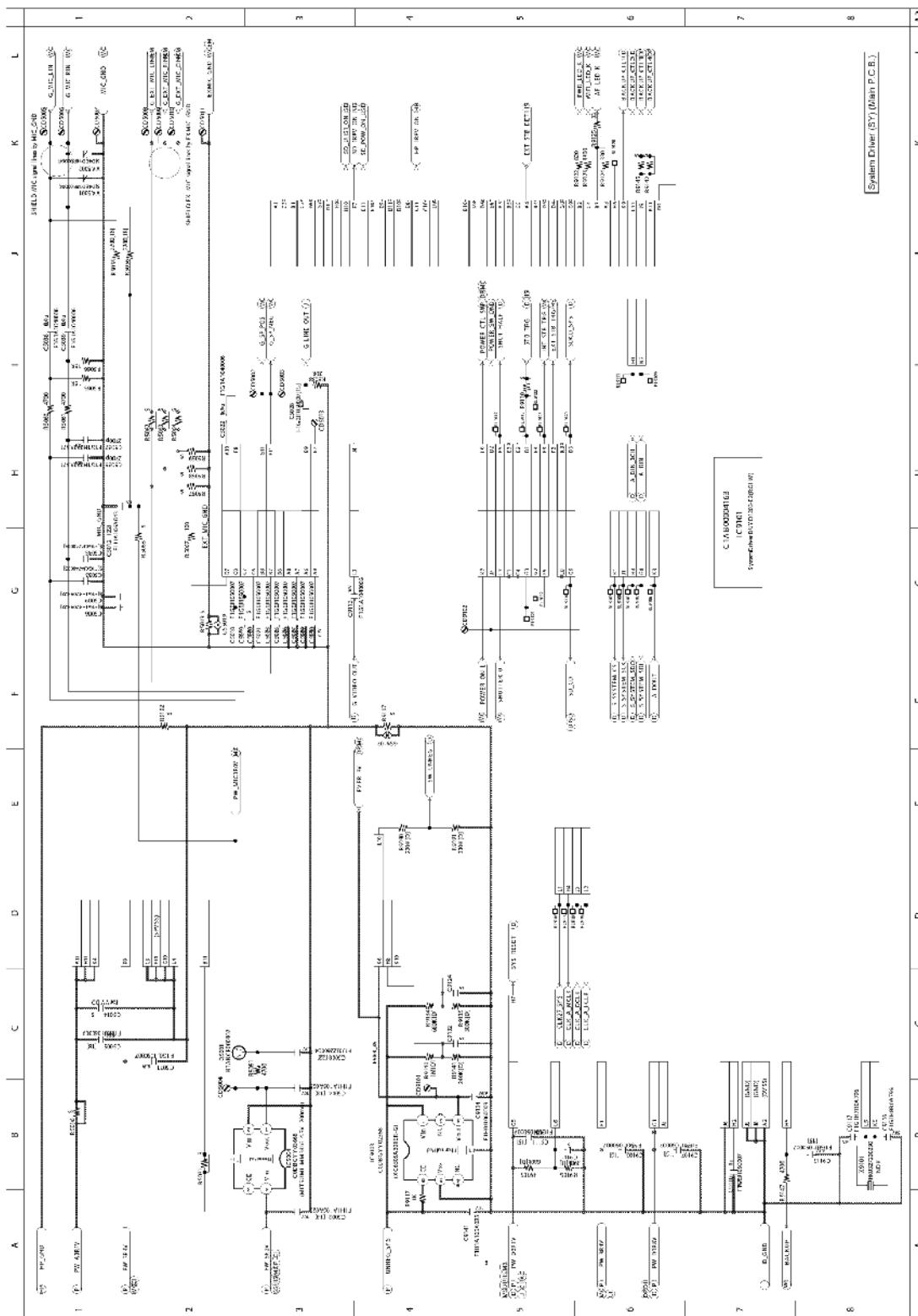

# Model No. : DMC-FZ2000/FZ2500 Main Connection 2 (LI) (Main P.C.B.)

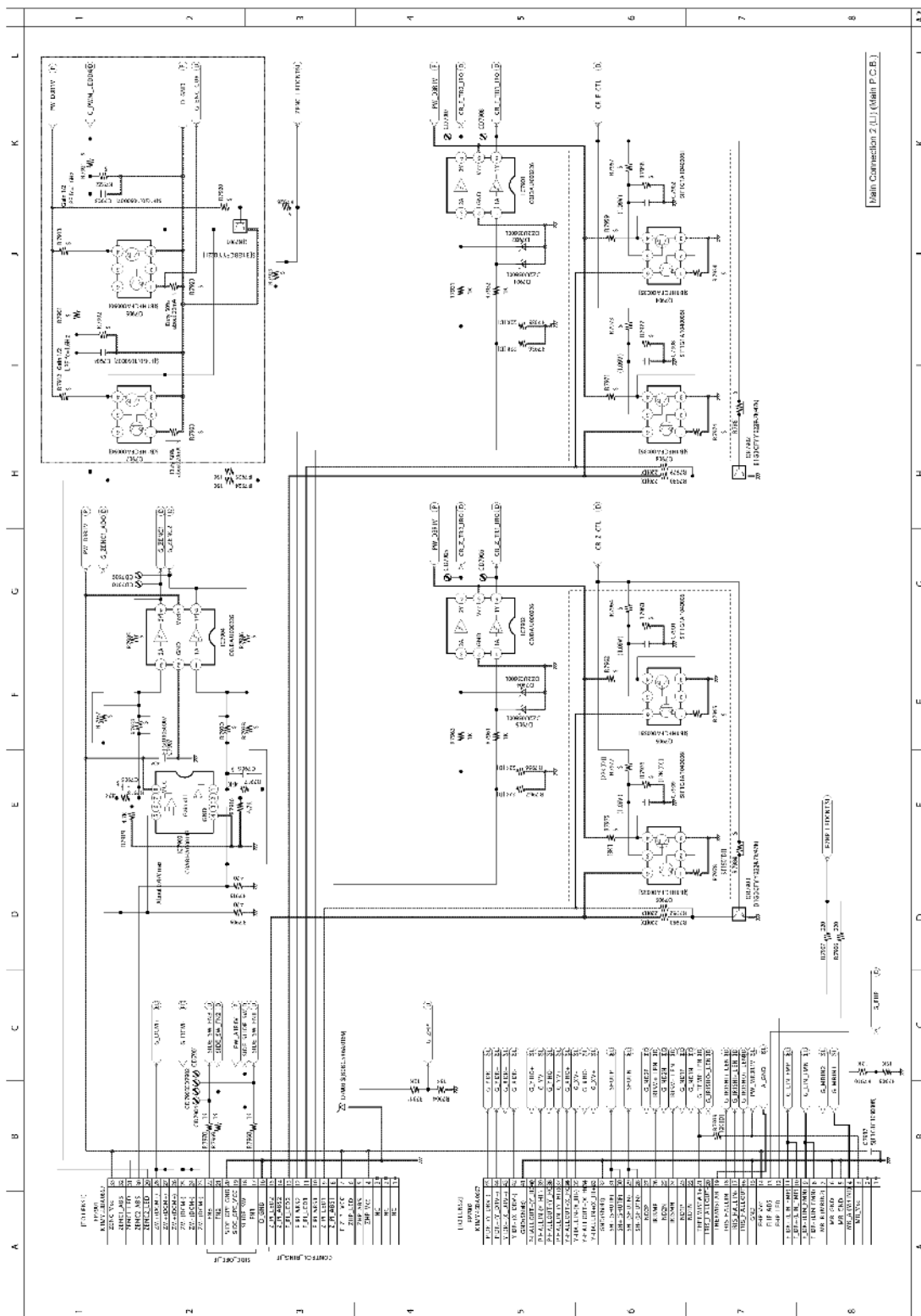

**Model No. : DMC-FZ2000/FZ2500 Flash (Top P.C.B.)**

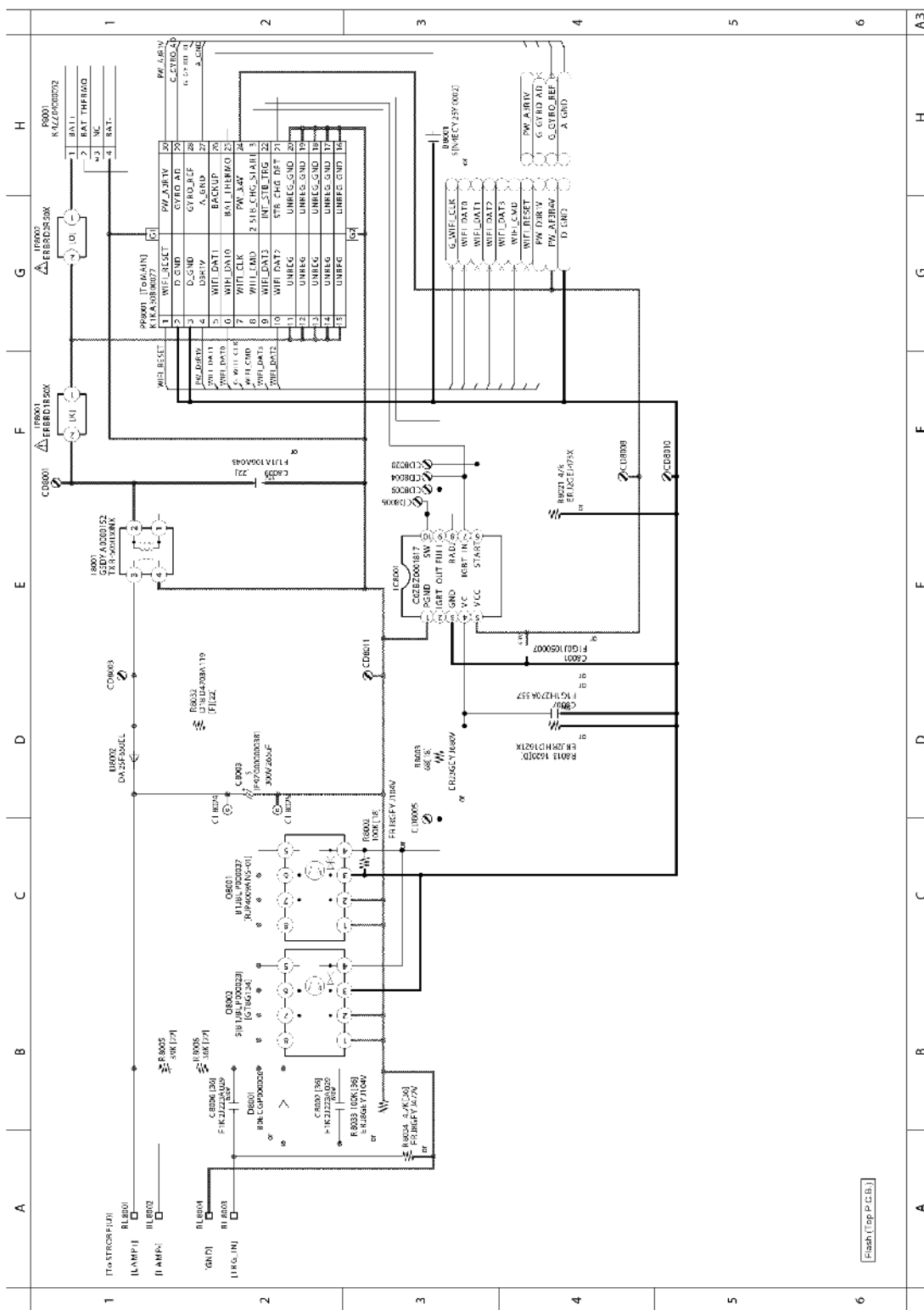

Model No. : DMC-FZ2000/FZ2500 Wi-Fi (Top P.C.B.)

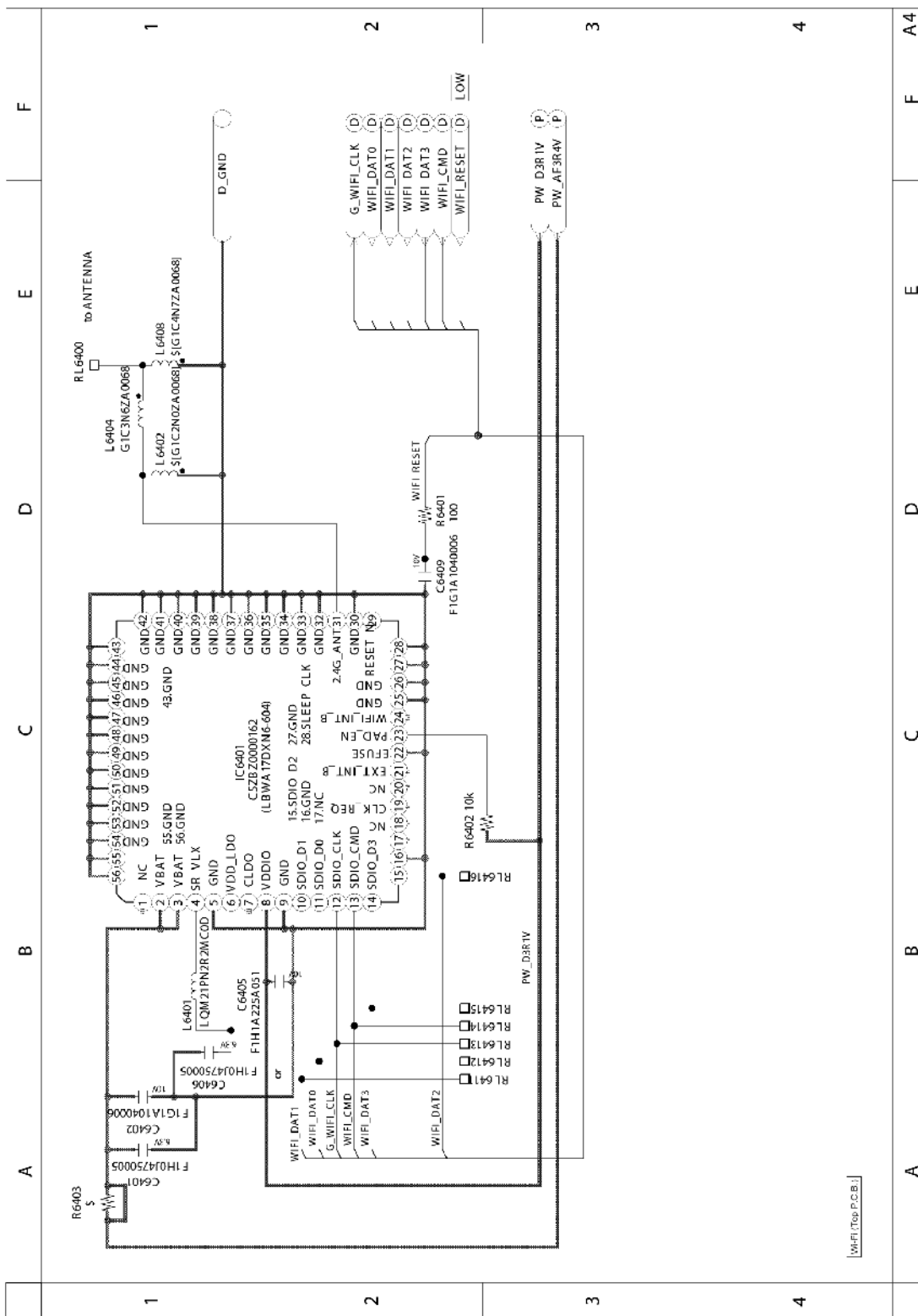

Model No. : DMC-FZ2000/FZ2500 EX Gyro (Top P.C.B.)

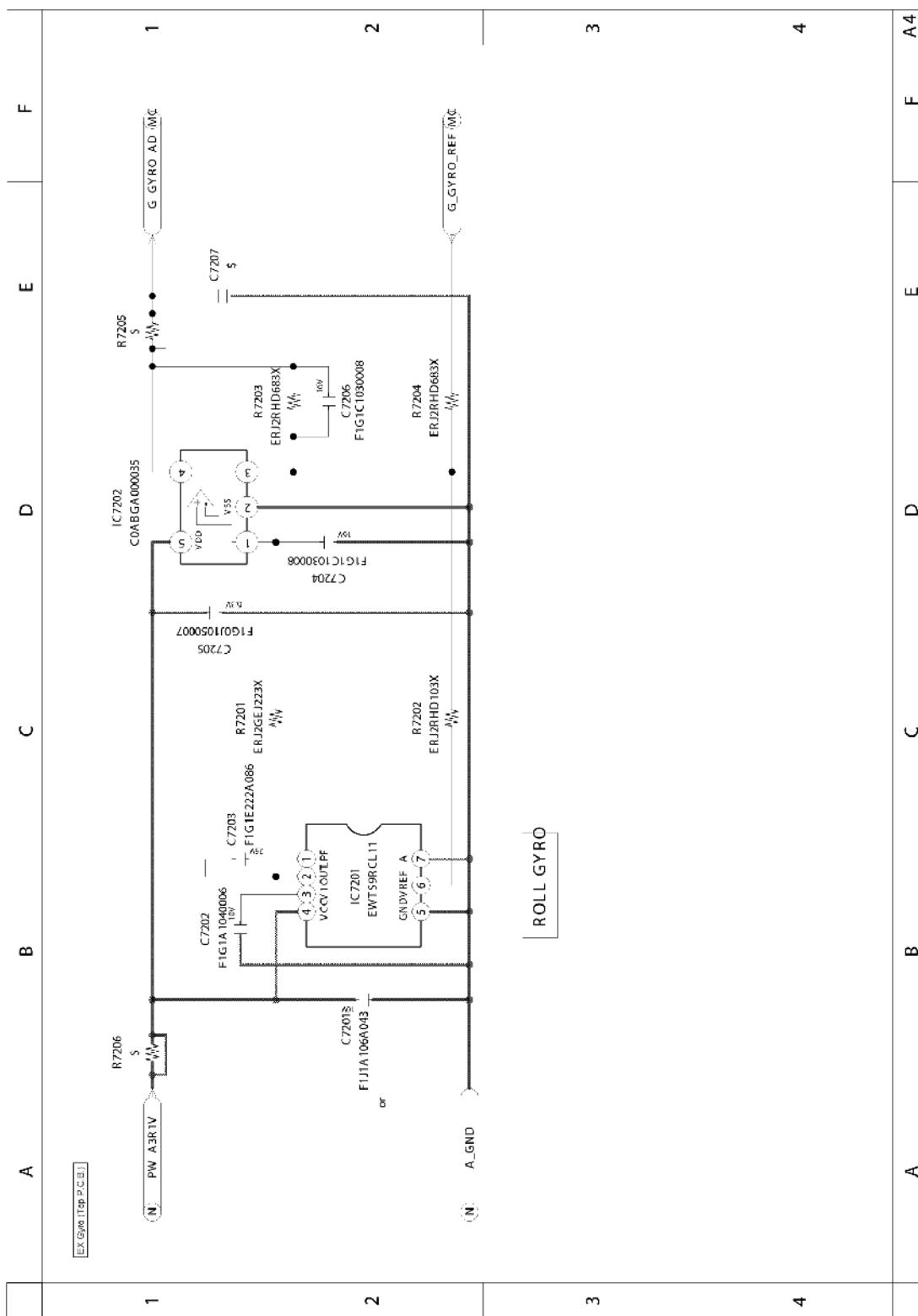





# Model No. : DMC-FZ2000/FZ2500 Lens Flex (Lens Flex P.C.B.)

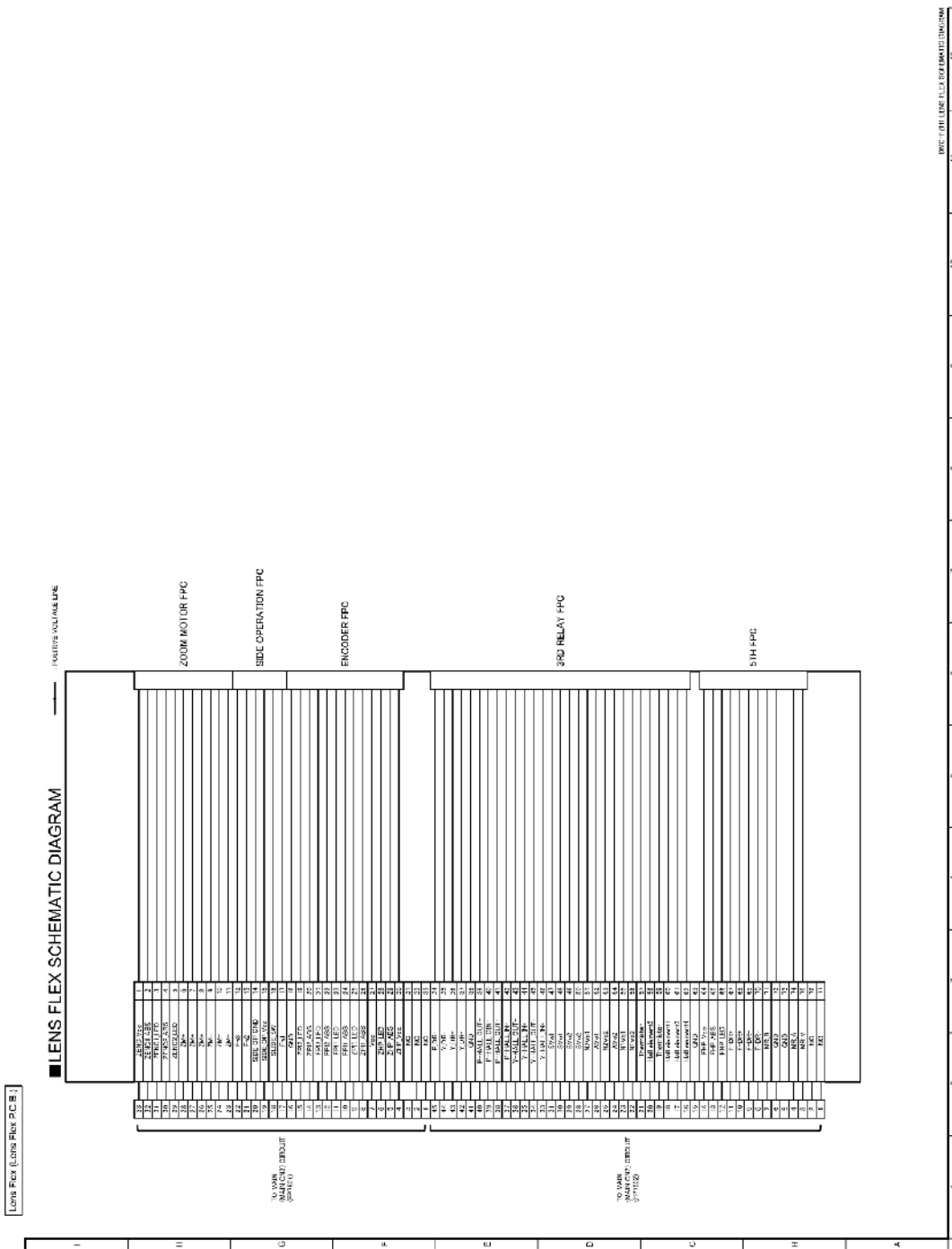

---

**Model No. : DMC-FZ2000/FZ2500 Main P.C.B. (Component Side)**

---

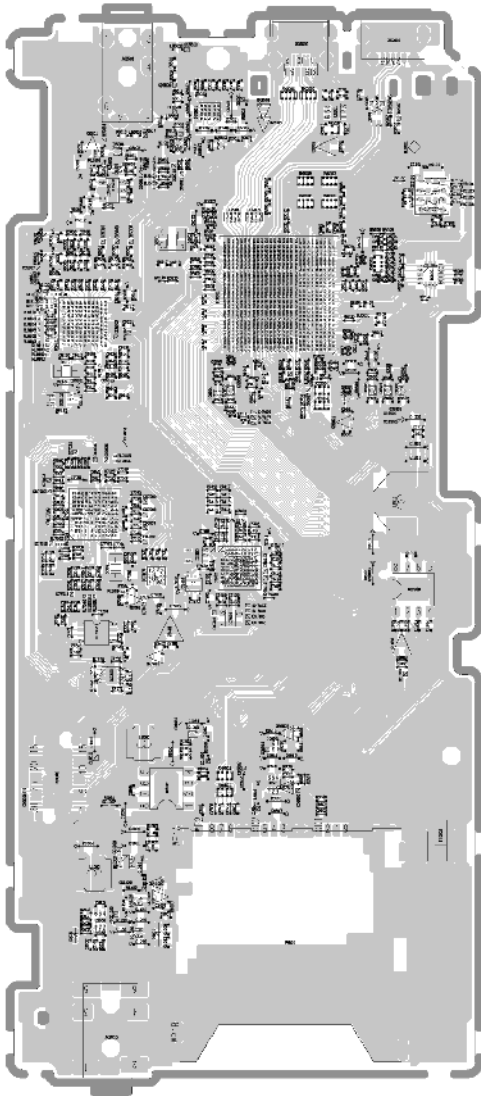

---

**Model No. : DMC-FZ2000/FZ2500 Main P.C.B. (Foil Side)**

---

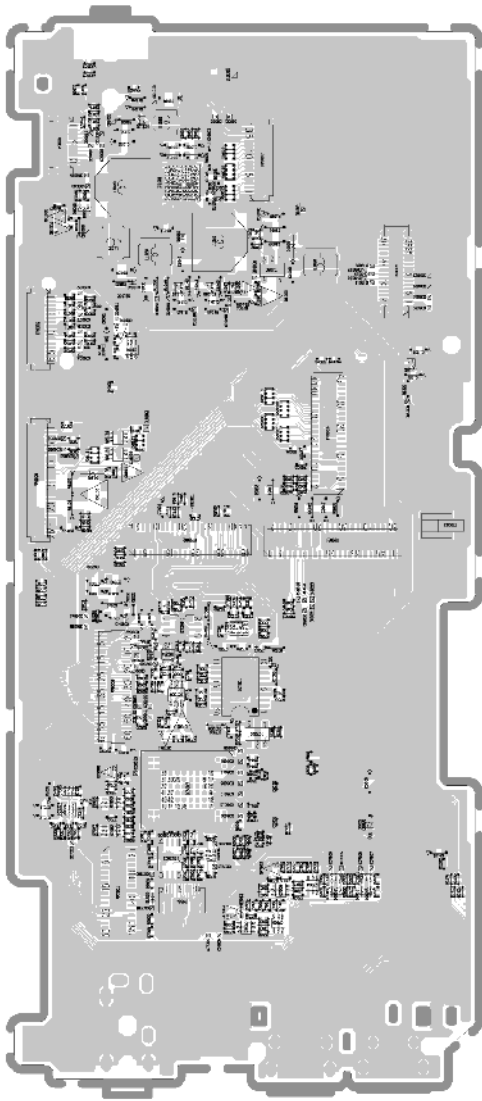

---

**Model No. : DMC-FZ2000/FZ2500 Flash P.C.B. (Component Side)**

---

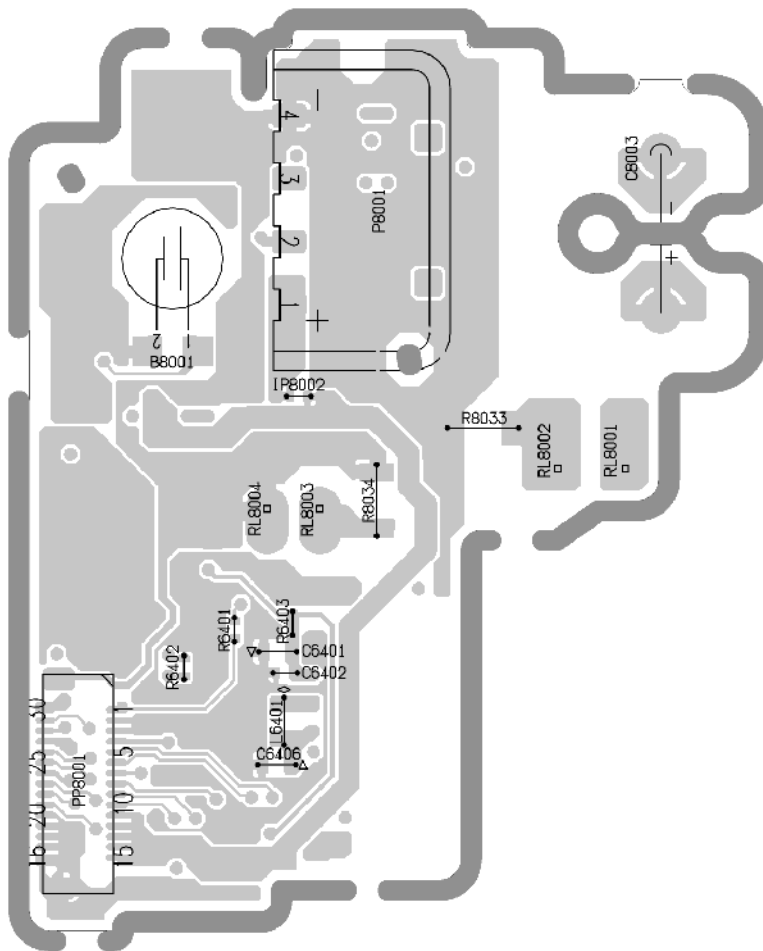

Model No. : DMC-FZ2000/FZ2500 Flash P.C.B. (Foil Side)

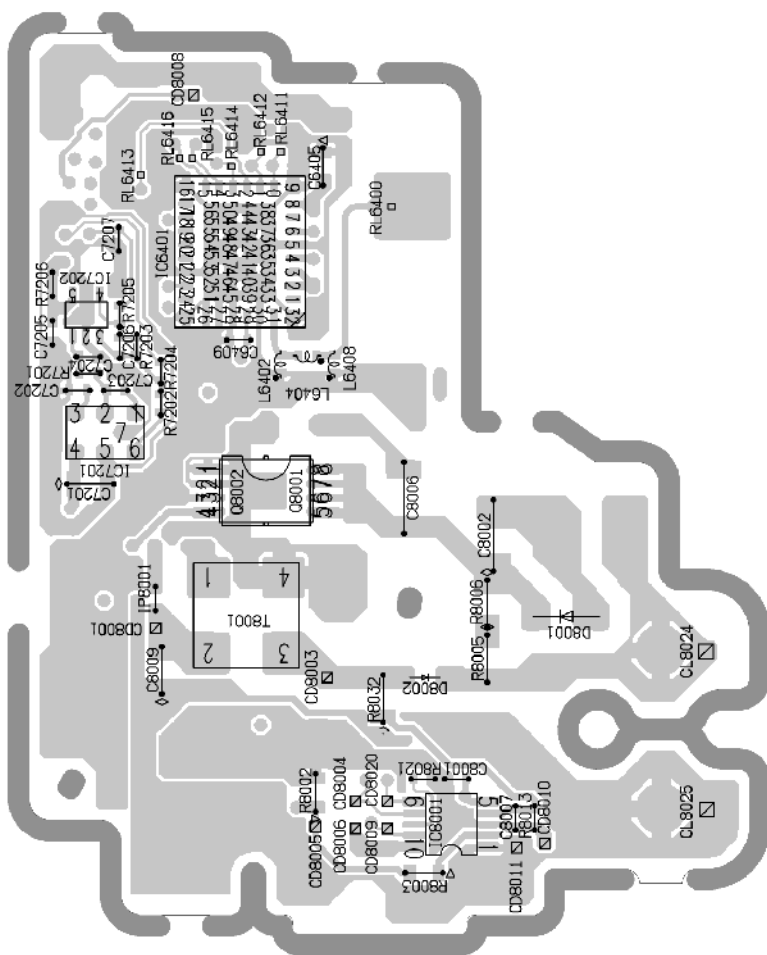

---

**Model No. : DMC-FZ2000/FZ2500 Sub P.C.B. (Component Side)**

---

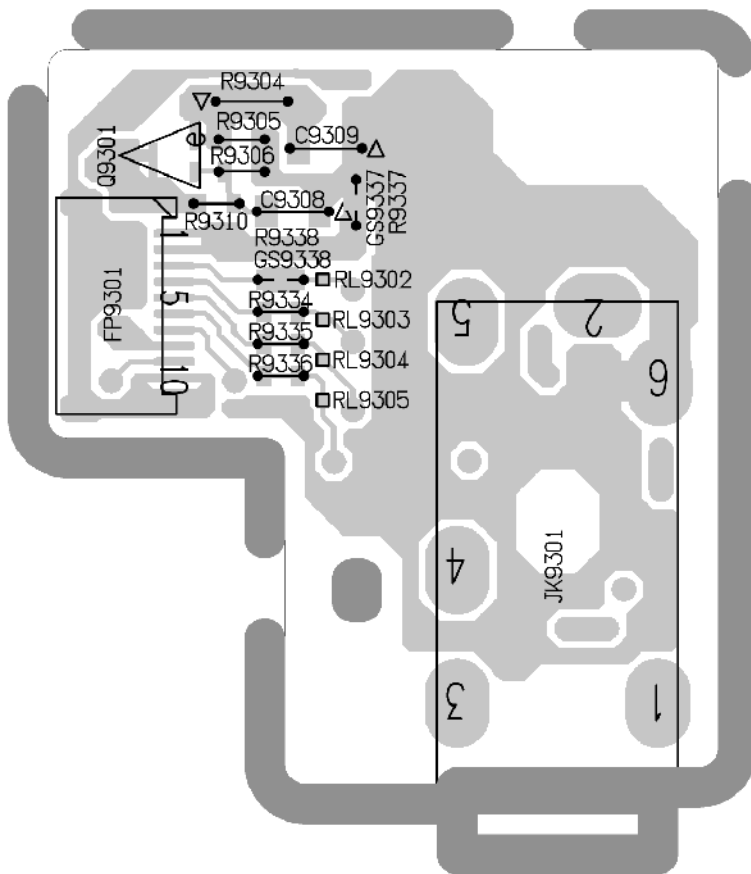

---

**Model No. : DMC-FZ2000/FZ2500 Sub P.C.B. (Foil Side)**

---

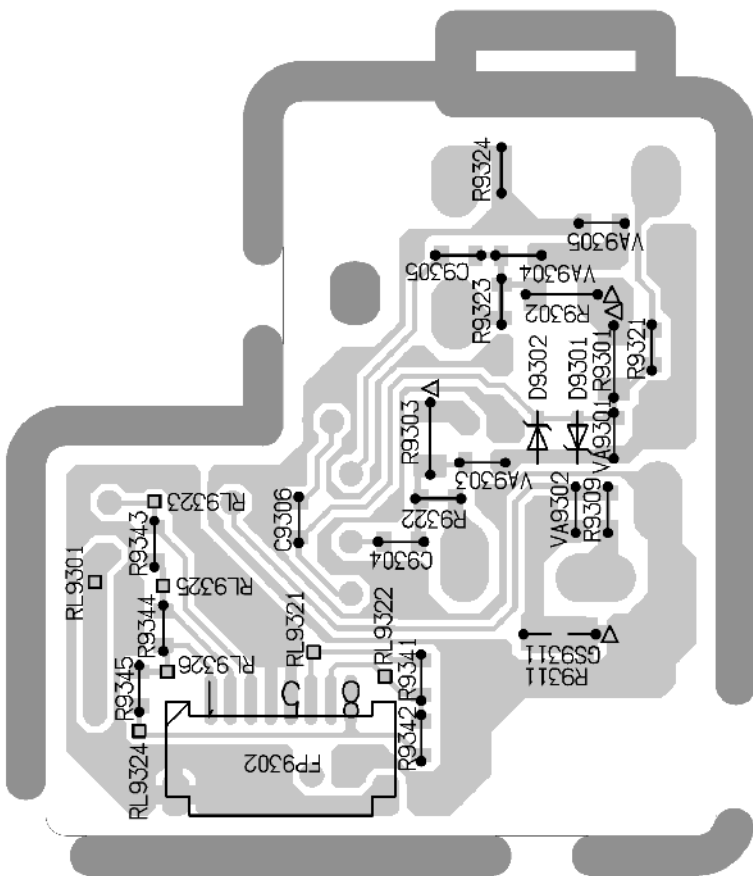

---

**Model No. : DMC-FZ2000/FZ2500 Lens Flex P.C.B.**

---

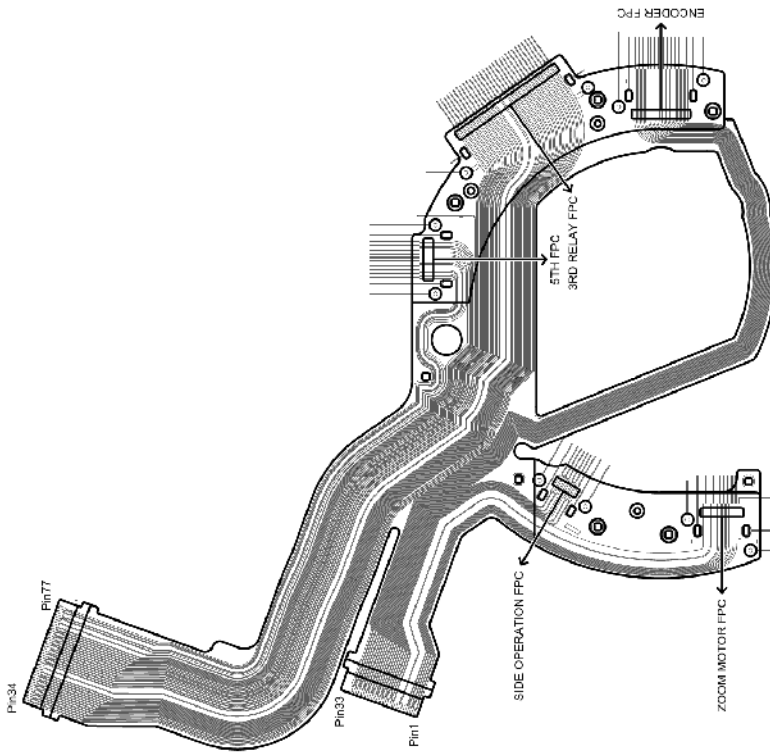



**Model No. : DMC-FZ2000/FZ2500 Parts List**

Change	Safety	Ref. No.	Part No.	Part Name & Description	Q'ty	Remarks
		C7201	F1J1A106A043	C.CAPACITOR CH 10V 10U	1	
		C7202	F1G1C104A077	C.CAPACITOR CH 10V 0.1U	1	
		C7203	F1G1E222A086	C.CAPACITOR CH 25V 2200P	1	
		C7204	F1G1C1030008	C.CAPACITOR CH 16V 0.01U	1	
		C7205	F1G0J1050007	C.CAPACITOR CH 6.3V 1U	1	
		C7206	F1G1C1030008	C.CAPACITOR CH 16V 0.01U	1	
		C8001	F1G0J1050007	C.CAPACITOR CH 6.3V 1U	1	
		C8002	F1K2J223A029	C.CAPACITOR 630V 0.022U	1	
		C8006	F1K2J223A029	C.CAPACITOR 630V 0.022U	1	
		C8007	F1G1H270A557	C.CAPACITOR CH 50V 27P	1	
		C8009	F1J1A106A043	C.CAPACITOR CH 10V 10U	1	
		D1001	B0JCGD000016	DIODE	1	E.S.D.
		D1050	B0ACRC000001	DIODE	1	E.S.D.
		D1090	B0ACRC000001	DIODE	1	E.S.D.
		D5401	DZ2U05600L	DIODE	1	E.S.D.
		D7901	DZ2U05600L	DIODE	1	E.S.D.
		D7902	DZ2U05600L	DIODE	1	E.S.D.
		D7904	DZ2U05600L	DIODE	1	E.S.D.
		D7905	DZ2U05600L	DIODE	1	E.S.D.
		D8001	B0ECGF000006	DIODE	1	E.S.D.
		D8002	DA2SF650EL	DIODE	1	E.S.D.
		D8101	DZ2J082M0L	DIODE	1	E.S.D.
		D8103	B2ABAP000007	DIODE	1	E.S.D.
		D9004	DZ2U05600L	DIODE	1	E.S.D.
		D9005	DZ2U05600L	DIODE	1	E.S.D.
		ET2002	K4CC01000001	EARTH SPRING	1	
		ET2003	K4CC01000001	EARTH SPRING	1	
		FL2001	EXC28CH900U	FILTER	1	
		FL2002	EXC28CH900U	FILTER	1	
		FP7901	K1MY33BA0667	CONNECTOR 33P	1	
		FP7902	K1MY45BA0667	CONNECTOR 45P	1	
		FP9001	K1MY51BA0667	CONNECTOR 51P	1	
		FP9002	K1MY16BA0633	CONNECTOR 16P	1	
		FP9003	K1MY45BA0667	CONNECTOR 45P	1	
		FP9006	K1MY26BA0633	CONNECTOR 26P	1	
		FP9007	K1MY16BA0633	CONNECTOR 16P	1	
		FP9008	K1MY10BA0633	CONNECTOR 10P	1	
		FP9009	K1MY61AA0288	CONNECTOR 61P	1	
		IC1001	C1ZBZ0004906	IC	1	E.S.D.
		IC1060	C0DBGYY05343	IC	1	E.S.D.
		IC1061	C0DBAYY01645	IC	1	E.S.D.
		IC1080	C0DBAYY02115	IC	1	E.S.D.
		IC1090	C0DBAYY02118	IC	1	E.S.D.
		IC1120	C0DBGYY03614	IC	1	E.S.D.
		IC1140	C0DBGYY03640	IC	1	E.S.D.
		IC1220	C0DBGYY03614	IC	1	E.S.D.
		IC1240	C0DBGYY05360	IC	1	E.S.D.
		IC1320	C0DBGYY03614	IC	1	E.S.D.
		IC1420	C0DBGYY03614	IC	1	E.S.D.
		IC1910	C0DBAYY01645	IC	1	E.S.D.
		IC5004	C0DBGYY03668	IC	1	E.S.D.
		IC5403	C0BBAA000008	IC	1	E.S.D.
		IC5501	C1AB00004335	IC	1	E.S.D.
		IC5502	C0DBGYY03614	IC	1	E.S.D.
		IC6001	VSG1033	IC	1	E.S.D.
		IC6003	1VK1FZ2000	IC	1	E.S.D.
		IC6201	L2EE00000038	IC	1	E.S.D.
		IC6501	C0DBGYY00779	IC	1	E.S.D.
		IC6601	C0DBGYY05582	IC	1	E.S.D.
		IC6602	C0DBGYY05590	IC	1	E.S.D.
		IC6603	C0DBGYY05584	IC	1	E.S.D.

		IC6604	COZBZ0002095	IC		1	E.S.D.
--	--	--------	--------------	----	--	---	--------

**Model No. : DMC-FZ2000/FZ2500 Parts List**

Change	Safety	Ref. No.	Part No.	Part Name & Description	Q'ty	Remarks
		IC6605	C0ZBZ0002264	IC	1	E.S.D.
		IC6606	C0ZBZ0002264	IC	1	E.S.D.
		IC7001	C1AB00003449	IC	1	E.S.D.
		IC7101	EWTS9PDL1A	IC	1	E.S.D. [INBD]
		IC7201	EWTS9RCL1A	IC	1	E.S.D. [INBD]
		IC7202	C0ABGA000035	IC	1	E.S.D.
		IC7300	C0JBAZ002390	IC	1	E.S.D.
		IC7301	C0GBY0000241	IC	1	E.S.D.
		IC7302	C0ABAA000055	IC	1	E.S.D.
		IC7304	C0ABGA000090	IC	1	E.S.D.
		IC7305	C0JBAB001160	IC	1	E.S.D.
		IC7307	C0GBY0000153	IC	1	E.S.D.
		IC7308	C0GBC0000028	IC	1	E.S.D.
		IC7310	C0ABHA000070	IC	1	E.S.D.
		IC7401	C0DBGYY00909	IC	1	E.S.D.
		IC7402	C1AB00003719	IC	1	E.S.D.
		IC7403	C0JBAB001130	IC	1	E.S.D.
		IC7404	C0GBY0000242	IC	1	E.S.D.
		IC7901	C0JBAU000226	IC	1	E.S.D.
		IC7902	C0JBAU000226	IC	1	E.S.D.
		IC7903	C0ABHA000143	IC	1	E.S.D.
		IC7904	C0JBAU000226	IC	1	E.S.D.
		IC8001	C0ZBZ0001817	IC	1	E.S.D.
		IC9101	C1AB00004163	IC	1	E.S.D.
		IC9103	C0DBGYY02368	IC	1	E.S.D.
	⚠	IP8001	ERBRD1R50X	FUSE	1	
	⚠	IP8002	ERBRD2R50X	FUSE	1	
	⚠	IP9001	ERBRD0R75X	FUSE	1	
	⚠	IP9002	ERBRD0R31X	FUSE	1	
		JK2001	K1FY105E0014	JACK	1	
		JK2002	K1FY119E0057	JACK	1	
		JK2003	K2HD104D0002	JACK	1	
		JK5501	K2HC106E0009	JACK	1	
		L1010	G1C4R7MA0392	CHIP INDUCTOR 4.7UH	1	
		L1020	G1C100MA0535	CHIP INDUCTOR	1	
		L1030	G1C100MA0461	CHIP INDUCTOR 10UH	1	
		L1040	G1C100MA0535	CHIP INDUCTOR	1	
		L1050	G1C100MA0461	CHIP INDUCTOR 10UH	1	
		L1060	G1C2R2MA0477	CHIP INDUCTOR 2.2UH	1	
		L1080	G1C100MA0461	CHIP INDUCTOR 10UH	1	
		L1090	G1C4R7MA0477	CHIP INDUCTOR 4.7UH	1	
		L1910	G1C1R5Z00011	CHIP INDUCTOR	1	
		L2001	J0ZZB0000142	CHIP INDUCTOR	1	
		L6001	G1C2R2KA0096	CHIP INDUCTOR 2.2UH	1	
		L7001	G1C100MA0408	CHIP INDUCTOR 10UH	1	
		LB2004	J0JCC0000415	FILTER	1	
		LB5401	J0JBC0000107	FILTER	1	
		LB5402	J0JBC0000107	FILTER	1	
		LB5403	J0JBC0000107	FILTER	1	
		LB5404	J0JBC0000107	FILTER	1	
		LB5521	J0JBC0000107	FILTER	1	
		LB5522	J0JBC0000107	FILTER	1	
		LB5523	J0JBC0000107	FILTER	1	
		LB5524	J0JBC0000107	FILTER	1	
		LB6002	J0JFC0000006	FILTER	1	
		LB6003	J0JCC0000317	FILTER	1	
		P6501	K1NA09E00166	CONNECTOR 9P	1	
		P8001	K4ZZ04000052	CONNECTOR 4P	1	
		P9004	K1MY10BA0557	CONNECTOR 10P	1	
		PP8001	K1KA30B00077	CONNECTOR 30P	1	
		PS9001	K1KB30AA0116	CONNECTOR 30P	1	

		Q1060	B1CFJD000007	TRANSISTOR	1	E.S.D.
--	--	-------	--------------	------------	---	--------

**Model No. : DMC-FZ2000/FZ2500 Parts List**

Change	Safety	Ref. No.	Part No.	Part Name & Description	Q'ty	Remarks
		Q1081	MTM861270LBF	TRANSISTOR	1	E.S.D.
		Q1090	B1CHQB000012	TRANSISTOR	1	E.S.D.
		Q2001	B1CFGD000003	TRANSISTOR	1	E.S.D.
		Q2002	B1CFJD000007	TRANSISTOR	1	E.S.D.
		Q2031	B1HFCFA00050	TRANSISTOR	1	E.S.D.
		Q5001	B1ABCF000302	TRANSISTOR	1	E.S.D.
		Q6501	MTM861270LBF	TRANSISTOR	1	E.S.D.
		Q7091	B1ABCF000302	TRANSISTOR	1	E.S.D.
		Q7301	B1ADGE000014	TRANSISTOR	1	E.S.D.
		Q7401	B1CHRD000092	TRANSISTOR	1	E.S.D.
		Q8001	B1JBLP000037	TRANSISTOR	1	E.S.D.
		Q8101	B1CFJD000007	TRANSISTOR	1	E.S.D.
		QR1002	B1GBCFYY0222	TRANSISTOR-RESISTOR	1	E.S.D.
		QR1003	B1GBCFYY0151	TRANSISTOR-RESISTOR	1	E.S.D.
		QR1004	B1GBCFYY0217	TRANSISTOR-RESISTOR	1	E.S.D.
		QR1005	B1GBCFYY0217	TRANSISTOR-RESISTOR	1	E.S.D.
		QR1081	B1GBCFYY0217	TRANSISTOR-RESISTOR	1	E.S.D.
		QR1090	B1GBCFYY0219	TRANSISTOR-RESISTOR	1	E.S.D.
		QR2001	B1GBCFYY0222	TRANSISTOR-RESISTOR	1	E.S.D.
		QR2002	B1GBCFYY0151	TRANSISTOR-RESISTOR	1	E.S.D.
		QR6501	B1GBCFYY0217	TRANSISTOR-RESISTOR	1	E.S.D.
		QR6502	B1GBCFYY0150	TRANSISTOR-RESISTOR	1	E.S.D.
		QR6601	B1GBCFYY0217	TRANSISTOR-RESISTOR	1	E.S.D.
		QR7301	B1GBCFYY0221	TRANSISTOR-RESISTOR	1	E.S.D.
		QR7401	B1GBCFYY0221	TRANSISTOR-RESISTOR	1	E.S.D.
		QR7902	B1GBCFYY0221	TRANSISTOR-RESISTOR	1	E.S.D.
		QR7903	B1GBCFYY0221	TRANSISTOR-RESISTOR	1	E.S.D.
		QR8101	B1GBCFYY0021	TRANSISTOR-RESISTOR	1	E.S.D.
		QR8102	B1GBCFYY0021	TRANSISTOR-RESISTOR	1	E.S.D.
		R7201	D0GA223JA023	M.RESISTOR CH 1/10W 22K	1	
		R7202	D1BA1002A022	M.RESISTOR CH 1/16W 10K	1	
		R7203	D1BA6802A022	M.RESISTOR CH 1/16W 68K	1	
		R7204	D1BA6802A022	M.RESISTOR CH 1/16W 68K	1	
		R8002	D0GB104JA065	M.RESISTOR CH 1/10W 100K	1	
		R8003	D0GB680JA065	M.RESISTOR CH 1/10W 68	1	
		R8005	D0GD393JA052	M.RESISTOR CH 1/10W 39K	1	
		R8006	D0GD393JA052	M.RESISTOR CH 1/10W 36K	1	
		R8013	D1BA1621A022	M.RESISTOR CH 1/16W1.621K	1	
		R8021	D0GA473JA023	M.RESISTOR CH 1/10W 47K	1	
		R8032	D1BD4703A119	M.RESISTOR CH 1/3W 470K	1	
		R8033	D0GF104JA048	RESISTOR	1	
		R8034	D0GF472JA048	RESISTOR	1	
		RX2003	EXB24V472JX	RESISTOR NETWORKS	1	
		RX6001	D1H81034A042	RESISTOR NETWORKS	1	
		RX6003	D1H84734A042	RESISTOR NETWORKS	1	
		RX6004	D1H81814A042	RESISTOR NETWORKS	1	
		RX6501	D1H84734A042	RESISTOR NETWORKS	1	
		RX6502	D1H83304A042	RESISTOR NETWORKS	1	
		RX8111	D1H83314A042	RESISTOR NETWORKS	1	
		RX8112	D1H81034A042	RESISTOR NETWORKS	1	
		RX9007	D1H81014A042	RESISTOR NETWORKS	1	
		RX9008	D1H81014A042	RESISTOR NETWORKS	1	
		RX9009	D1H81014A042	RESISTOR NETWORKS	1	
		RX9010	D1H81014A042	RESISTOR NETWORKS	1	
		RX9011	D1H81024A042	RESISTOR NETWORKS	1	
		RX9012	D1H81024A042	RESISTOR NETWORKS	1	
		RX9013	D1H81024A042	RESISTOR NETWORKS	1	
		T8001	G5DYA0000152	TRANSFORMER	1	
		TH6001	D4CC11030013	THERMISTORS	1	
		VA2031	D4ED18R00008	VARISTOR	1	
		VA2032	D4ED18R00008	VARISTOR	1	

		VA2033	D4ED18R00008	VARISTOR	1	
--	--	--------	--------------	----------	---	--

---

**Model No. : DMC-FZ2000/FZ2500 Parts List**

---

Change	Safety	Ref. No.	Part No.	Part Name & Description	Q'ty	Remarks
		X6001	H0J240500048	CRYSTAL OSCILLATOR	1	
		X7091	H0J327200230	CRYSTAL OSCILLATOR	1	
		X9101	H0J327200230	CRYSTAL OSCILLATOR	1	

Model No. : DMC-FZ2000/FZ2500 Frame and Casing Section

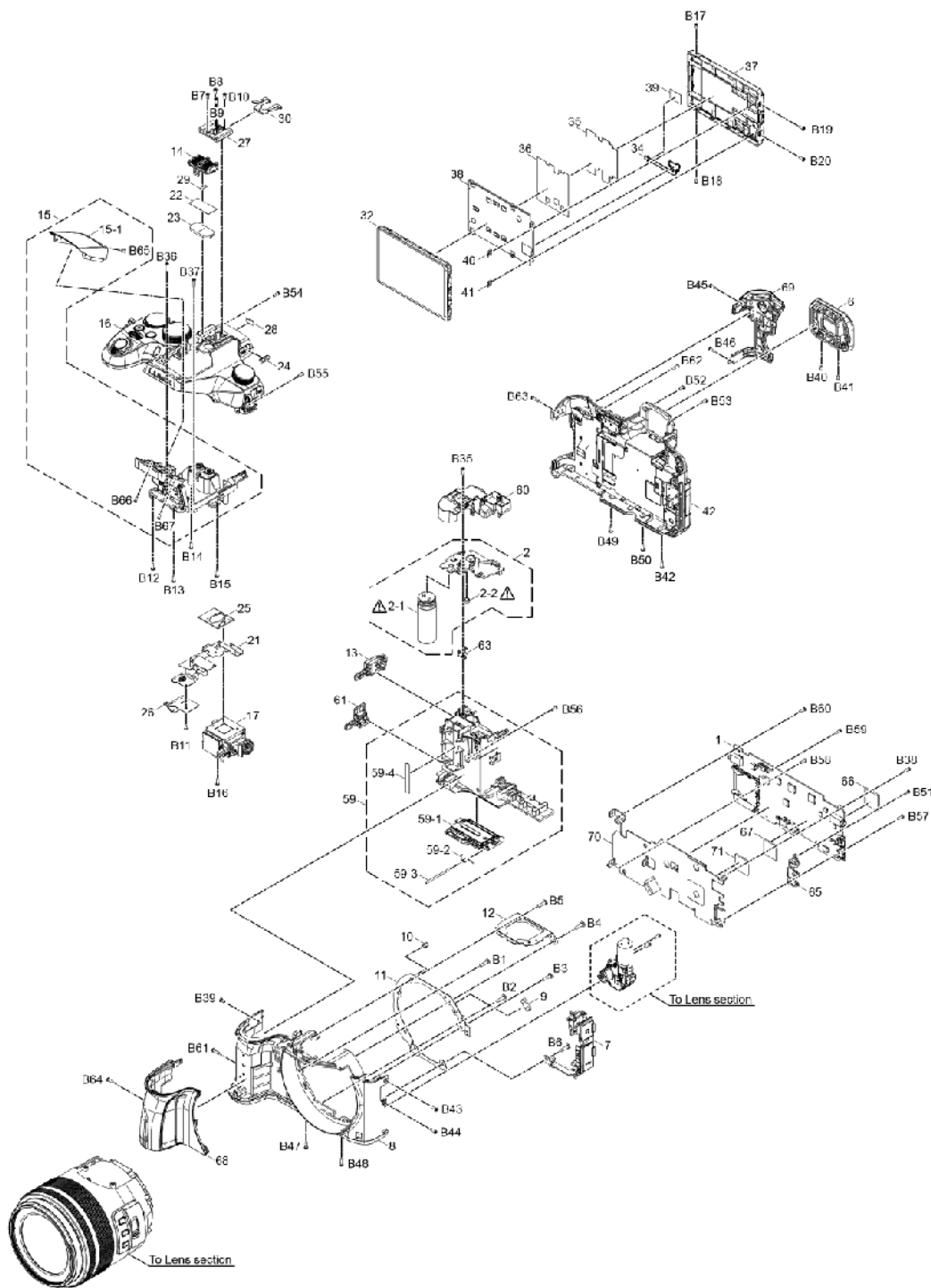



Model No. : DMC-FZ2000/FZ2500 Camera Lens Section

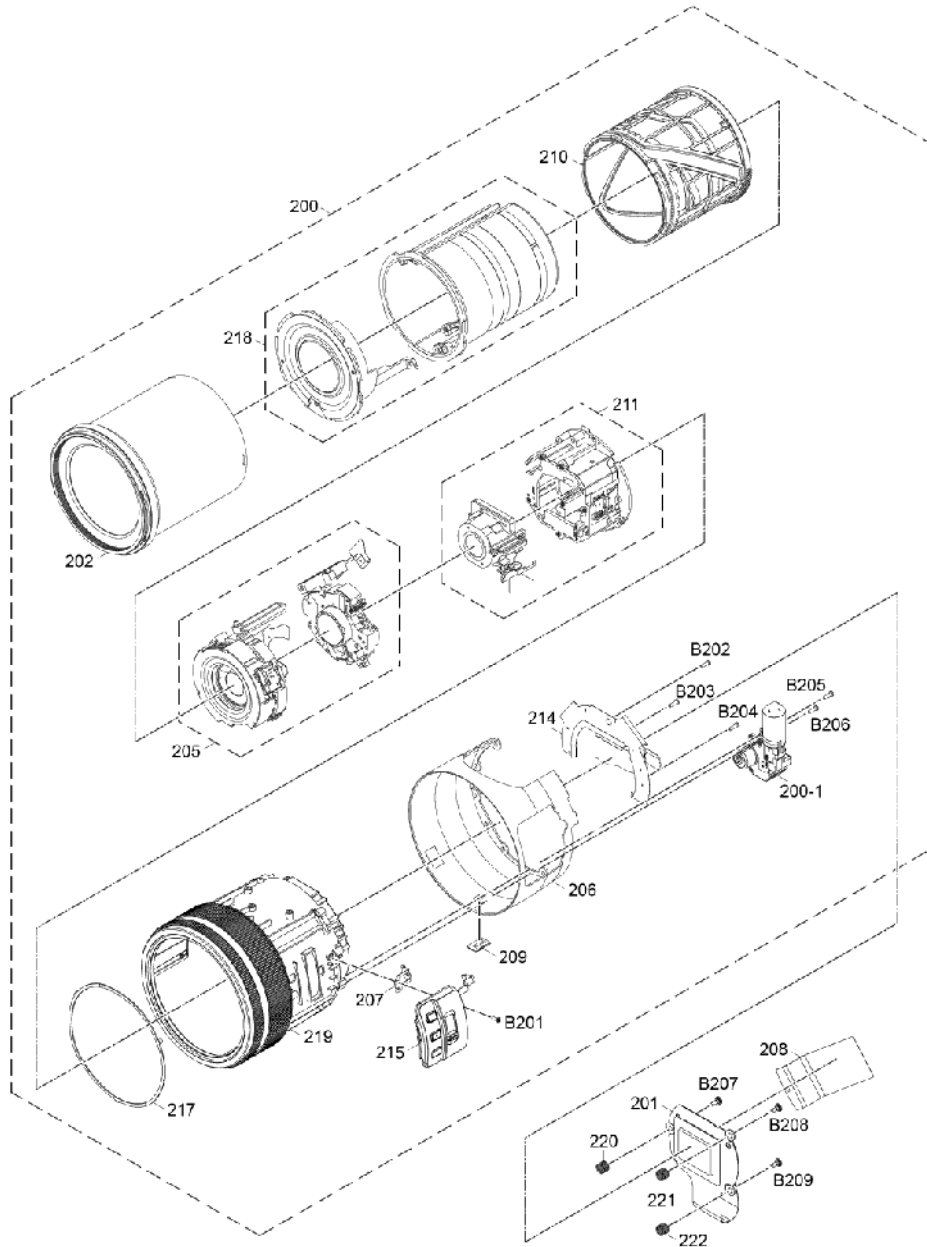

**Model No. : DMC-FZ2000/FZ2500 Packing Parts and Accessories Section**

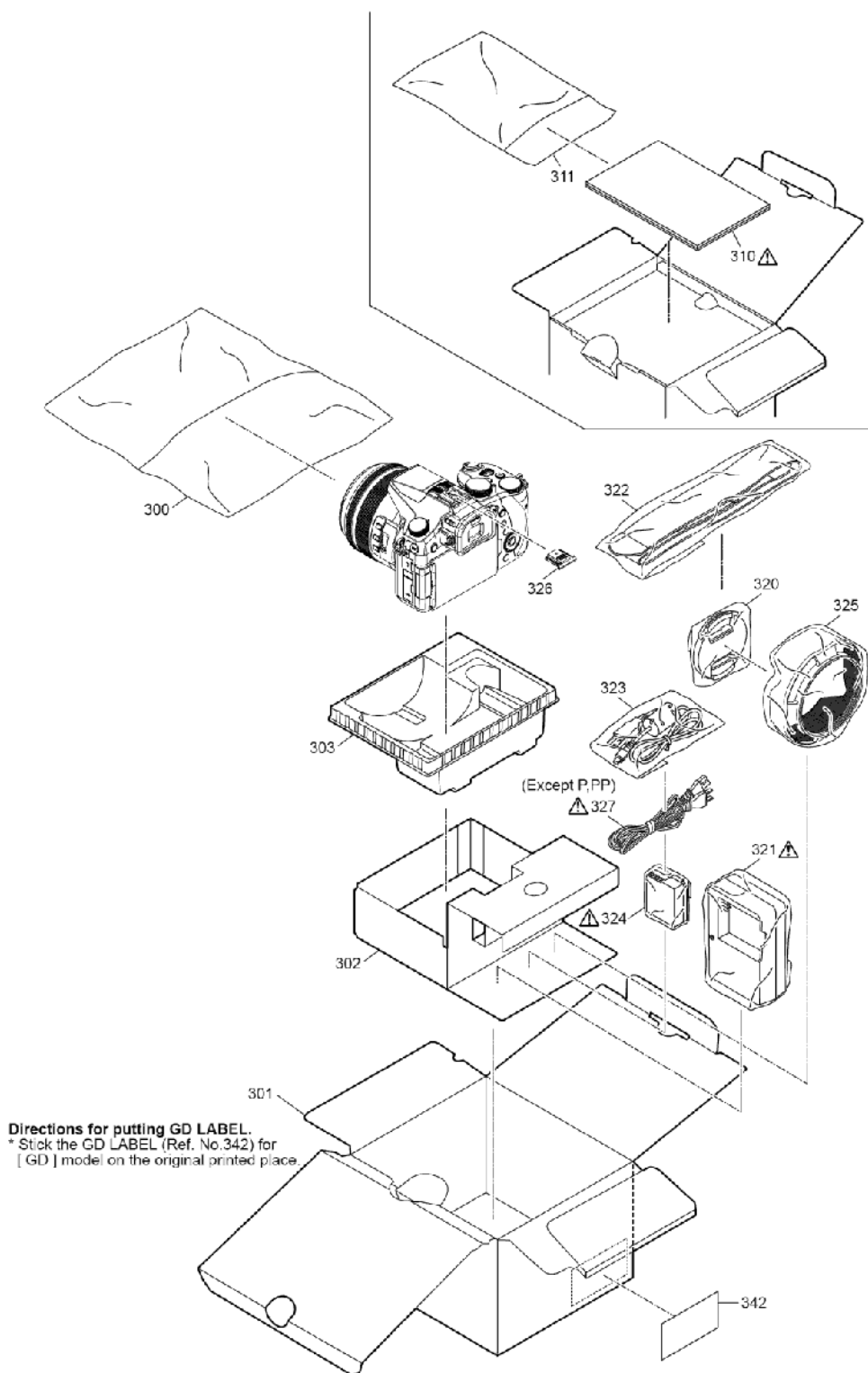

**Model No. : DMC-FZ2000/FZ2500 Parts List**

Change	Safety	Ref. No.	Part No.	Part Name & Description	Q'ty	Remarks
		1	SEP0881AA	MAIN P.C.B.	1	(RTL)E.S.D.
		2	2SE1MCFZH1Z	FLASH P.C.B. UNIT	1	
	⚠	2-1	F9Z000000038	E.CAPACITOR	1	(C8003)
	⚠	2-2	ML-421S/DB	BUTTON BATTERY	1	(B8001)
		6	1KE1MCFZH1Z	EYE CUP UNIT	1	
		7	1KK1MCFZH1Z	JACK HOLDER UNIT	1	
		8	1KM2MCFZH1Z	FRONT CASE UNIT	1	
		9	DVMC1019Z	GASKET	1	
		10	DVMC1023Z	GASKET	1	
		11	SMP0336	LENS PLATE	1	
		12	SMP0337	LENS TOP PLATE	1	
		13	2KK1MCFZH1Z	REMOTE COVER UNIT	1	
		14	DVGM1001Z	MIC NET	1	
		15	2KE1MCFZH1Z	FLASH UNIT	1	
		15-1	SKK0439K	FLASH CASE TOP	1	
		16	2KM2MCFZH1Z	TOP CASE UNIT	1	
		17	4SE1MCFZH1Z	LVF UNIT	1	
		21	SEP0886AA	MULTI FPC	1	
		22	SGQ0066	MIC NET B	1	
		23	SGQ0072	MIC CUSHION TOP	1	
		24	SGU0021	FLASH LOCK KNOB	1	
		25	SMP0340	HOT SHOE PLATE	1	
		26	SMP0341	FLASH EARTH PLATE	1	
		27	VEK0U23-M	HOT SHOE UNIT	1	
		28	VGQ0P93	TAPE	1	
		29	VGQ8918-B	MICROPHONE TAPE	1	
		30	VMC2111	SHOE SPRING	1	
		32	3GE2MCFZH1Z	LCD TOP CASE UNIT	1	
		34	SEP0433AA	MR SW FPC	1	
		35	SEP0849AA	LCD IF P.C.B.	1	
		36	SGQ0627	LCD BEZEL SHEET	1	
		37	SKK0310K	LCD CASE BOTTOM	1	
		38	SMP0205	LCD BEZEL	1	
		39	VGQ1U00	FPC TAPE	1	
		40	VMP0D70	LCD EARTH PLATE	1	
		41	VMP0D70	LCD EARTH PLATE	1	
		42	1KM1DC2610Z	REAR CASE UNIT	1	
		59	4KM2MCFZH1Z	BATTERY CASE UNIT	1	
		59-1	3KK1MCFZH1Z	BATTERY DOOR UNIT	1	
		59-2	SMB0038	BATTERY DOOR SPRING	1	
		59-3	VMS8026	BATTERY DOOR SHAFT	1	
		59-4	SGQ0285	CAPACITOR TAPE	1	
		60	SGQ0832	CAPACITOR COVER	1	
		61	SKF0155K	COUPLER COVER	1	
		63	SMP0344	BATTERY EARTH	1	
		65	SMQ1098	USB JACK HOLDER	1	
		66	SGQ0212	THERMAL SHEET	1	
		67	SGQ0212	THERMAL SHEET	1	
		68	SGQ0823	FRONT GRIP	1	
		69	SGQ0824	REAR GRIP	1	
		70	SMP0342	BATTERY PLATE	1	
		71	DVMC1028Z	GASKET	1	
		B1	XTV2+8JFN	SCREW	1	
		B2	XTV2+8JFN	SCREW	1	
		B3	XTV2+8JFN	SCREW	1	
		B4	XTV2+8JFN	SCREW	1	
		B5	XTV2+8JFN	SCREW	1	
		B6	XTV2+8JFN	SCREW	1	
		B7	VHD2200	SCREW	1	
		B8	VHD2200	SCREW	1	
		B9	VHD2200	SCREW	1	

		B10	VHD2200	SCREW	1	
--	--	-----	---------	-------	---	--

**Model No. : DMC-FZ2000/FZ2500 Parts List**

Change	Safety	Ref. No.	Part No.	Part Name & Description	Q'ty	Remarks
		B11	VHD2457	SCREW	1	
		B12	XQN16+BJ5FN	SCREW	1	
		B13	XQN16+BJ5FN	SCREW	1	
		B14	XQN16+BJ5FN	SCREW	1	
		B15	XQN16+BJ5FN	SCREW	1	
		B16	XQN16+BJ5FN	SCREW	1	
		B17	VHD2206	SCREW	1	
		B18	VHD2206	SCREW	1	
		B19	VHD2337	SCREW	1	
		B20	VHD2337	SCREW	1	
		B35	XQN16+BJ5FN	SCREW	1	
		B36	VHD2178	SCREW	1	
		B37	VHD2178	SCREW	1	
		B38	VHD2247-A	SCREW	1	
		B39	VHD2301-A	SCREW	1	
		B40	VHD2325	SCREW	1	
		B41	VHD2325	SCREW	1	
		B42	VHD2438	SCREW	1	
		B43	VHD2438	SCREW	1	
		B44	VHD2438	SCREW	1	
		B45	VHD2471	SCREW	1	
		B46	VHD2471	SCREW	1	
		B47	VHD2471	SCREW	1	
		B48	VHD2471	SCREW	1	
		B49	VHD2471	SCREW	1	
		B50	VHD2471	SCREW	1	
		B51	XQN14+BJ4FNK	SCREW	1	
		B52	XQN16+BJ4FN	SCREW	1	
		B53	XQN16+BJ4FN	SCREW	1	
		B54	XQN16+BJ5FN	SCREW	1	
		B55	XQN16+BJ5FN	SCREW	1	
		B56	XQN16+BJ5FN	SCREW	1	
		B57	XQN16+BJ5FN	SCREW	1	
		B58	XQN16+BJ5FN	SCREW	1	
		B59	XQN16+BJ5FN	SCREW	1	
		B60	XQN16+BJ5FN	SCREW	1	
		B61	XQN16+BJ65FC	SCREW	1	
		B62	XQN16+BJ65FC	SCREW	1	
		B63	XQN16+BJ65FC	SCREW	1	
		B64	XQN16+BJ65FC	SCREW	1	
		B65	VHD2476	SCREW	1	
		B66	VHD2476	SCREW	1	
		B67	VHD2476	SCREW	1	
		200	10U1FZH1L4Z	LENS UNIT (W/O MOS)	1	
		200-1	L6DBYYE0001	ZOOM MOTOR	1	
		201	18E1FZH1L4Z	MOS UNIT	1	
		202	10U1FZH1L1Z	1ST LENS FRAME UNIT	1	
		205	SXP0155	3G SHUTTER UNIT	1	
		206	SDW0423K	REAR RING	1	
		207	SMA0413	EARTH PLATE	1	
		208	SZT0318	RADIATION SHEET	1	
		209	SDW0421K	LENS RING FOOT	1	
		210	SXQ0757	CAM FRAME UNIT	1	
		211	SXP0156	4TH-5TH LENS FRAME UNIT	1	
		214	18E1FZH1Z	LENS FPC UNIT	1	
		215	SYU0085	SIDE OPERATION UNIT	1	
		217	SMC0092	WAVE WASHER	1	
		218	10U1FZH1L2Z	2ND-INNER FRAME UNIT	1	
		219	10U1FZH1L3Z	LENS EXTERIOR UNIT	1	
		220	VMB4541	TILT SPRING	1	
		221	VMB4541	TILT SPRING	1	

		222	VMB4541	TILT SPRING	1	
--	--	-----	---------	-------------	---	--

**Model No. : DMC-FZ2000/FZ2500 Parts List**

Change	Safety	Ref. No.	Part No.	Part Name & Description	Q'ty	Remarks
		B201	VHD2296	SCREW	1	
		B202	VHD1974	SCREW	1	
		B203	VHD1974	SCREW	1	
		B204	VHD1974	SCREW	1	
		B205	VHD1974	SCREW	1	
		B206	VHD1974	SCREW	1	
		B207	VHD2351	SCREW	1	
		B208	VHD2351	SCREW	1	
		B209	VHD2351	SCREW	1	
		300	SPF0081	CAMERA BAG	1	
		301	SPK0230	PACKING CASE	1	EG, EP, EF, EB
		301	SPK0229	PACKING CASE	1	P, PP, GA, GC, GH, GN, GD
		301	SPK0235	PACKING CASE	1	GK
		302	SPN0557	PAD	1	
		303	SPN0556	CUSHION	1	
	⚠	310	DVQX1031Z	BASIC O/I (GERMAN)	1	EG
	⚠	310	DVQX1032Z	BASIC O/I (FRENCH)	1	EG, EF
	⚠	310	DVQX1033Z	BASIC O/I (ITALIAN)	1	EG
	⚠	310	DVQX1034Z	BASIC O/I (DUTCH)	1	EG, EF
	⚠	310	DVQX1035Z	BASIC O/I (SPANISH)	1	EG
	⚠	310	DVQX1036Z	BASIC O/I (PORTUGUESE)	1	EG
	⚠	310	DVQX1037Z	BASIC O/I (FINNISH)	1	EP
	⚠	310	DVQX1038Z	BASIC O/I (DANISH)	1	EP
	⚠	310	DVQX1039Z	BASIC O/I (SWEDISH)	1	EP
	⚠	310	DVQX1040Z	BASIC O/I (POLISH)	1	EP
	⚠	310	DVQX1041Z	BASIC O/I (CZECH)	1	EP
	⚠	310	DVQX1042Z	BASIC O/I (HUNGARIAN)	1	EP
	⚠	310	DVQX1043Z	BASIC O/I (ENGLISH)	1	EB
	⚠	310	DVQX1028Z	BASIC O/I (ENGLISH)	1	P, PP
	⚠	310	DVQX1029Z	BASIC O/I (SPANISH)	1	P, PP
	⚠	310	DVQX1030Z	BASIC O/I (FRENCH)	1	PP
	⚠	310	DVQX1044Z	BASIC O/I (ENGLISH)	1	GA, GH
	⚠	310	DVQX1045Z	BASIC O/I (CHINESE (TRADITIONAL))	1	GA, GH
	⚠	310	DVQX1047Z	BASIC O/I (ARABIC)	1	GA, GC
	⚠	310	DVQX1046Z	BASIC O/I (ENGLISH)	1	GC
	⚠	310	DVQX1048Z	BASIC O/I (CHINESE (SIMPLIFIED))	1	GK
	⚠	310	DVQX1049Z	BASIC O/I (ENGLISH)	1	GN
	⚠	310	DVQX1050Z	BASIC O/I (KOREAN)	1	GD
		311	VPF1542	BAG, POLYETHYLENE	1	
		320	SYQ0862	LENS CAP	1	
	⚠	321	DE-A80AD/SX	BATTERY CHARGER	1	EG, EP, EF, EB, GN
	⚠	321	DE-A79BB/SX	BATTERY CHARGER	1	P, PP
	⚠	321	DE-A80BE/SX	BATTERY CHARGER	1	GA, GC, GH, GK, GD
		322	DVPW1002Z	SHOULDER STRAP	1	
		323	K1HY04YY0106	USB CABLE W/PLUG	1	
	⚠	324	-----	BATTERY PACK	1	
		325	SYQ0847	LENS HOOD	1	
		326	VYF3522	HOT SHOE COVER	1	
	⚠	327	K2CQ2YY00082	AC CORD W/PLUG	1	EG, EP, EF, GA
	⚠	327	K2CT3YY00034	AC CORD W/PLUG	1	EB, GC, GH
	⚠	327	K2CP2YY00083	AC CORD W/PLUG	1	GA
	⚠	327	K2CA2YY00130	AC CORD W/PLUG	1	GK
	⚠	327	K2CJ2YY00052	AC CORD W/PLUG	1	GN
	⚠	327	K2CR2YY00026	AC CORD W/PLUG	1	GD
		342	VQL2J61	GD LABEL	1	GD