

Service Manual

Digital Camera

LUMIX

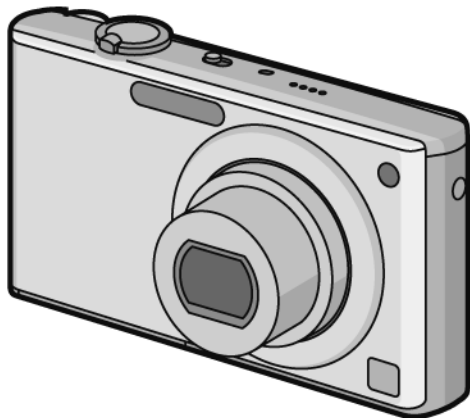

- Model No. **DMC-FX40EB**
DMC-FX40EE
DMC-FX40EF
DMC-FX40EG
DMC-FX40EP
DMC-FX40SG
DMC-FX48P
DMC-FX48PC
DMC-FX48PU
DMC-FX48GC
DMC-FX48GD
DMC-FX48GH
DMC-FX48GJ
DMC-FX48GK
DMC-FX48GT

Vol. 1

Colour

- (S).....Silver Type (except PC/EF/GD)
(K).....Black Type
(P).....Pink Type (except P/PC/PU/EB/EF/EP)
(R).....Red Type (only PC/EB/EE/EF/EG/EP/SG)
(W).....White Type (only EF/EG/GH)
(N).....Gold Type (only EE/ EP/GC/GK/SG)

WARNING

This service information is designed for experienced repair technicians only and is not designed for use by the general public. It does not contain warnings or cautions to advise non-technical individuals of potential dangers in attempting to service a product. Products powered by electricity should be serviced or repaired only by experienced professional technicians. Any attempt to service or repair the product or products dealt with in this service information by anyone else could result in serious injury or death.

Panasonic®

© Panasonic Corporation 2009. Unauthorized copying and distribution is a violation of law.

TABLE OF CONTENTS

	PAGE	PAGE
1 Safety Precaution	3	
1.1. General Guidelines	3	
1.2. Leakage Current Cold Check	3	
1.3. Leakage Current Hot Check (See Figure 1.)	3	
1.4. How to Discharge the Capacitor on Flash Top PCB	4	
2 Warning	5	
2.1. Prevention of Electrostatic Discharge (ESD) to Electrostatically Sensitive (ES) Devices	5	
2.2. How to Recycle the Lithium Ion Battery (U.S. Only)	5	
2.3. Caution for AC Cord(For EB/GC/GH)	6	
2.4. How to Replace the Lithium Battery	7	
3 Service Navigation	8	
3.1. Introduction	8	
3.2. General Description About Lead Free Solder (PbF)	8	
3.3. Important Notice 1:(Other than U.S.A. and Canadian Market)	8	
3.4. How to Define the Model Suffix (NTSC or PAL model)	9	
4 Specifications	13	
5 Location of Controls and Components	14	
6 Service Mode	16	
6.1. Error Code Memory Function	16	
6.2. ICS (Indication of additional Camera Settings when picture was taken) function	18	
7 Service Fixture & Tools	20	
7.1. Service Fixture and Tools	20	
7.2. When Replacing the Main PCB	21	
7.3. Service Position	21	
8 Disassembly and Assembly Instructions	22	
8.1. Disassembly Flow Chart	22	
8.2. PCB Location	22	
8.3. Disassembly Procedure	23	
8.4. Disassembly Procedure for the Lens	28	
8.5. Assembly Procedure for the Lens	30	
8.6. Removal of the CCD Unit	32	
8.7. Removal of the Focus Motor Unit	33	
8.8. The Applymt of Grease Method	33	
9 Measurements and Adjustments	34	
9.1. Matrix Chart for Replaced Part and Necessary Adjustment	34	
10 Maintenance	35	
10.1. Cleaning Lens and LCD Panel	35	

1 Safety Precaution

1.1. General Guidelines

1. IMPORTANT SAFETY NOTICE

There are special components used in this equipment which are important for safety. These parts are marked by

 in the Schematic Diagrams, Circuit Board Layout, Exploded Views and Replacement Parts List. It is essential that these critical parts should be replaced with manufacturer's specified parts to prevent X-RADIATION, shock, fire, or other hazards. Do not modify the original design without permission of manufacturer.

2. An Isolation Transformer should always be used during the servicing of AC Adaptor whose chassis is not isolated from the AC power line. Use a transformer of adequate power rating as this protects the technician from accidents resulting in personal injury from electrical shocks. It will also protect AC Adaptor from being damaged by accidental shorting that may occur during servicing.
3. When servicing, observe the original lead dress. If a short circuit is found, replace all parts which have been overheated or damaged by the short circuit.
4. After servicing, see to it that all the protective devices such as insulation barriers, insulation papers shields are properly installed.
5. After servicing, make the following leakage current checks to prevent the customer from being exposed to shock hazards.

1.2. Leakage Current Cold Check

1. Unplug the AC cord and connect a jumper between the two prongs on the plug.
2. Measure the resistance value, with an ohmmeter, between the jumpered AC plug and each exposed metallic cabinet part on the equipment such as screwheads, connectors, control shafts, etc. When the exposed metallic part has a return path to the chassis, the reading should be between $1\text{ M}\Omega$ and $5.2\text{ M}\Omega$. When the exposed metal does not have a return path to the chassis, the reading must be infinity.

1.3. Leakage Current Hot Check (See Figure 1.)

1. Plug the AC cord directly into the AC outlet. Do not use an isolation transformer for this check.
2. Connect a $1.5\text{ k}\Omega$, 10 W resistor, in parallel with a $0.15\text{ }\mu\text{F}$ capacitor, between each exposed metallic part on the set and a good earth ground, as shown in Figure 1.
3. Use an AC voltmeter, with $1\text{ k}\Omega/\text{V}$ or more sensitivity, to measure the potential across the resistor.
4. Check each exposed metallic part, and measure the voltage at each point.
5. Reverse the AC plug in the AC outlet and repeat each of the above measurements.
6. The potential at any point should not exceed 0.75 V RMS . A leakage current tester (Simpson Model 229 or equivalent) may be used to make the hot checks, leakage current must not exceed $1/2\text{ mA}$. In case a measurement is outside of the limits specified, there is a possibility of a shock hazard, and the equipment should be repaired and rechecked before it is returned to the customer.

Hot-Check Circuit

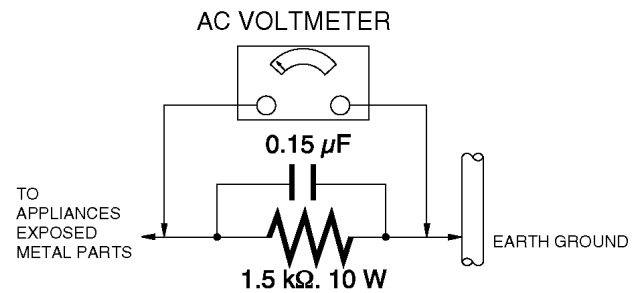

Figure. 1

1.4. How to Discharge the Capacitor on Flash Top PCB

CAUTION:

1. Be sure to discharge the capacitor on FLASH TOP PCB.
2. Be careful of the high voltage circuit on FLASH TOP PCB when servicing.

[Discharging Procedure]

1. Refer to the disassemble procedure and Remove the necessary parts/unit.
2. Put the insulation tube onto the lead part of Resistor (ERG5SJ102:1k Ω /5W).
(an equivalent type of resistor may be used.)
3. Put the resistor between both terminals of capacitor on FLASH TOP PCB for approx. 5 seconds.
4. After discharging confirm that the capacitor voltage is lower than 10V using a voltmeter.

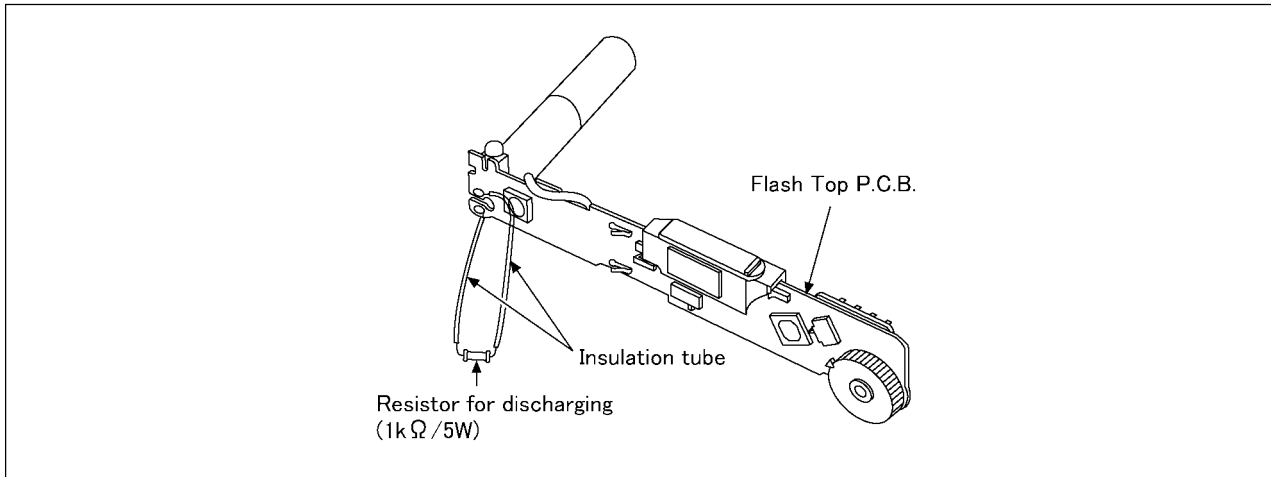

Fig. F1

2 Warning

2.1. Prevention of Electrostatic Discharge (ESD) to Electrostatically Sensitive (ES) Devices

Some semiconductor (solid state) devices can be damaged easily by static electricity. Such components commonly are called Electrostatically Sensitive (ES) Devices.

Examples of typical ES devices are CCD image sensor, IC (integrated circuits) and some field-effect transistors and semiconductor "chip" components.

The following techniques should be used to help reduce the incidence of component damage caused by electrostatic discharge (ESD).

1. Immediately before handling any semiconductor component or semiconductor-equipped assembly, drain off any ESD on your body by touching a known earth ground. Alternatively, obtain and wear a commercially available discharging ESD wrist strap, which should be removed for potential shock reasons prior to applying power to the unit under test.
2. After removing an electrical assembly equipped with ES devices, place the assembly on a conductive surface such as aluminum foil, to prevent electrostatic charge buildup or exposure of the assembly.
3. Use only a grounded-tip soldering iron to solder or unsolder ES devices.
4. Use only an antistatic solder removal device. Some solder removal devices not classified as "antistatic (ESD protected)" can generate electrical charge sufficient to damage ES devices.
5. Do not use freon-propelled chemicals. These can generate electrical charges sufficient to damage ES devices.
6. Do not remove a replacement ES device from its protective package until immediately before you are ready to install it. (Most replacement ES devices are packaged with leads electrically shorted together by conductive foam, aluminum foil or comparable conductive material).
7. Immediately before removing the protective material from the leads of a replacement ES device, touch the protective material to the chassis or circuit assembly into which the device will be installed.

CAUTION :

Be sure no power is applied to the chassis or circuit, and observe all other safety precautions.

8. Minimize bodily motions when handling unpackaged replacement ES devices. (Otherwise harmless motion such as the brushing together of your clothes fabric or the lifting of your foot from a carpeted floor can generate static electricity (ESD) sufficient to damage an ES device).

2.2. How to Recycle the Lithium Ion Battery (U.S. Only)

ENGLISH



A lithium ion battery that is recyclable powers the product you have purchased. Please call 1-800-8-BATTERY for information on how to recycle this battery.

FRANÇAIS



L'appareil que vous vous êtes procuré est alimenté par une batterie au lithium-ion recyclable. Pour des renseignements sur le recyclage de la batterie, veuillez composer le 1-800-8-BATTERY.

2.3. Caution for AC Cord (For EB/GC/GH)

2.3.1. Information for Your Safety

IMPORTANT

Your attention is drawn to the fact that recording of pre-recorded tapes or discs or other published or broadcast material may infringe copyright laws.

WARNING

To reduce the risk of fire or shock hazard, do not expose this equipment to rain or moisture.

CAUTION

To reduce the risk of fire or shock hazard and annoying interference, use the recommended accessories only.

FOR YOUR SAFETY

DO NOT REMOVE THE OUTER COVER

To prevent electric shock, do not remove the cover. No user serviceable parts inside. Refer servicing to qualified service personnel.

2.3.2. Caution for AC Mains Lead

For your safety, please read the following text carefully.

This appliance is supplied with a moulded three-pin mains plug for your safety and convenience.

A 5-ampere fuse is fitted in this plug.

Should the fuse need to be replaced please ensure that the replacement fuse has a rating of 5 amperes and it is approved by ASTA or BSI to BS1362

Check for the ASTA mark or the BSI mark on the body of the fuse.



If the plug contains a removable fuse cover you must ensure that it is refitted when the fuse is replaced.

If you lose the fuse cover, the plug must not be used until a replacement cover is obtained.

A replacement fuse cover can be purchased from your local Panasonic Dealer.

If the fitted moulded plug is unsuitable for the socket outlet in your home then the fuse should be removed and the plug cut off and disposed of safely.

There is a danger of severe electrical shock if the cut off plug is inserted into any 13-ampere socket.

If a new plug is to be fitted please observe the wiring code as shown below.

If in any doubt, please consult a qualified electrician.

2.3.2.1. Important

The wires in this mains lead are coloured in accordance with the following code:

Blue	Neutral
Brown	Live

As the colours of the wires in the mains lead of this appliance may not correspond with the coloured markings identifying the terminals in your plug, proceed as follows:

The wire which is coloured BLUE must be connected to the terminal in the plug which is marked with the letter N or coloured BLACK.

The wire which is coloured BROWN must be connected to the terminal in the plug which is marked with the letter L or coloured RED.

Under no circumstances should either of these wires be connected to the earth terminal of the three pin plug, marked with the letter E or the Earth Symbol.



2.3.2.2. Before Use

Remove the Connector Cover as follows.

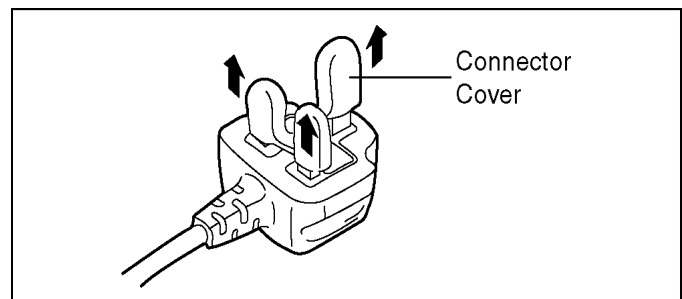

2.3.2.3. How to Replace the Fuse

1. Remove the Fuse Cover with a screwdriver.

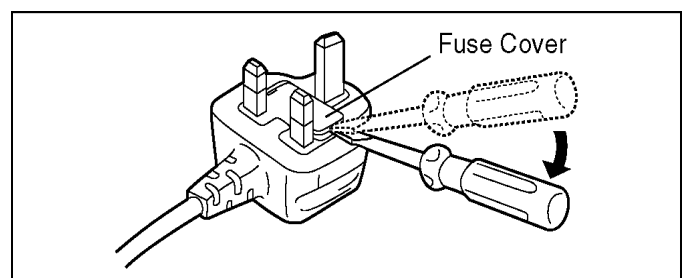

2. Replace the fuse and attach the Fuse cover.

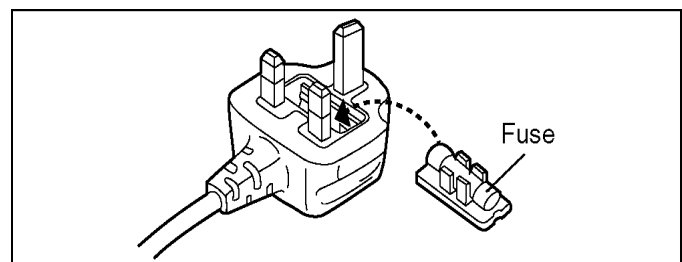

2.4. How to Replace the Lithium Battery

2.4.1. Replacement Procedure

1. Remove the SUB PCB. (Refer to Disassembly Procedures.)
2. Remove the Lithium battery (Ref. No. "B9801" at component side of SUB PCB) and then replace it into new one.

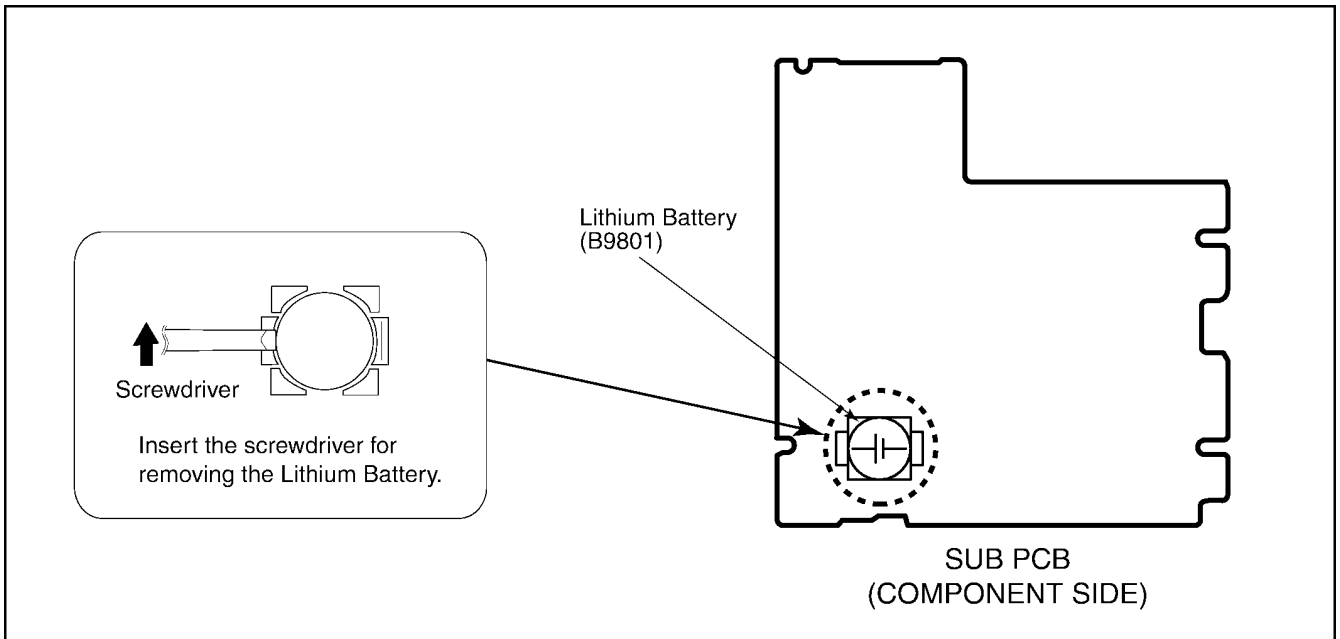

NOTE:

This Lithium battery is a critical component.

(Type No.: ML-421S/ZTK **Manufactured by Energy Company, Panasonic Corporation.**)

It must never be subjected to excessive heat or discharge.

It must therefore only be fitted in requirement designed specifically for its use.

Replacement batteries must be of same type and manufacture.

They must be fitted in the same manner and location as the original battery, with the correct polarity contacts observed.

Do not attempt to re-charge the old battery or re-use it for any other purpose.

It should be disposed of in waste products destined for burial rather than incineration.

(For English)

CAUTION

Danger of explosion if battery is incorrectly replaced.

Replace only with the same or equivalent type recommended by the manufacturer.

Dispose of used batteries according to the manufacturer's instructions.

(For German)

ACHTUNG

Explosionsgefahr bei falschem Anbringen der Batterie. Ersetzen Sie nur mit einem äquivalentem vom Hersteller empfohlenem Typ.

Behandeln Sie gebrauchte Batterien nach den Anweisungen des Herstellers.

(For French)

MISE EN GARDE

Une batterie de remplacement inappropriée peut exploser. Ne remplacez qu'avec une batterie identique ou d'un type recommandé par le fabricant. L'élimination des batteries usées doit être faite conformément aux instructions du fabricant.

NOTE:

Above caution is applicable for a battery pack which is for DMC-FX40/48 series, as well.

3 Service Navigation

3.1. Introduction

This service manual contains technical information, which allow service personnel's to understand and service this model.

Please place orders using the parts list and not the drawing reference numbers.

If the circuit is changed or modified, the information will be followed by service manual to be controlled with original service manual.

3.2. General Description About Lead Free Solder (PbF)

The lead free solder has been used in the mounting process of all electrical components on the printed circuit boards used for this equipment in considering the globally environmental conservation.

The normal solder is the alloy of tin (Sn) and lead (Pb). On the other hand, the lead free solder is the alloy mainly consists of tin (Sn), silver (Ag) and Copper (Cu), and the melting point of the lead free solder is higher approx.30°C (86°F) more than that of the normal solder.

Distinction of PCB Lead Free Solder being used

The letter of "PbF" is printed either foil side or components side on the PCB using the lead free solder.(See right figure)

PbF

Service caution for repair work using Lead Free Solder (PbF)

- The lead free solder has to be used when repairing the equipment for which the lead free solder is used.
(Definition: The letter of "PbF" is printed on the PCB using the lead free solder.)
- To put lead free solder, it should be well molten and mixed with the original lead free solder.
- Remove the remaining lead free solder on the PCB cleanly for soldering of the new IC.
- Since the melting point of the lead free solder is higher than that of the normal lead solder, it takes the longer time to melt the lead free solder.
- Use the soldering iron (more than 70W) equipped with the temperature control after setting the temperature at 350±30°C (662±86°F).

Recommended Lead Free Solder (Service Parts Route.)

- The following 3 types of lead free solder are available through the service parts route.
 - RFKZ03D01K----- (0.3mm 100g Reel)
 - RFKZ06D01K----- (0.6mm 100g Reel)
 - RFKZ10D01K----- (1.0mm 100g Reel)

Note

* Ingredient: tin (Sn) 96.5%, silver (Ag) 3.0%, Copper (Cu) 0.5%, Cobalt (Co) / Germanium (Ge) 0.1 to 0.3%

3.3. Important Notice 1:(Other than U.S.A. and Canadian Market)

1. The service manual does not contain the following information, because of the impossibility of servicing at component level without concerned equipment/facilities.
 - a. Schematic diagram, Block Diagram and PCB layout of MAIN PCB and SUB PCB.
 - b. Parts list for individual parts for MAIN PCB and SUB PCB.When a part replacement is required for repairing MAIN PCB and/or SUB PCB, replace as an assembled parts. (MAIN PCB/ SUB PCB)
2. The following category is/are recycle module part. please send it/them to Central Repair Center.
 - MAIN PCB (VEP56079A)
 - SUB PCB (VEP56080A): Excluding replacement of Lithium Battery

3.4. How to Define the Model Suffix (NTSC or PAL model)







There are eight kinds of DMC-FX40/FX48, regardless of the colours.

- a) DMC-FX40 (Japan domestic model), DMC-FX40SG
- b) DMC-FX48P/PC
- c) DMC-FX40EB/EF/EG/EP
- d) DMC-FX40EE
- e) DMC-FX48GT
- f) DMC-FX48GK
- g) DMC-FX48GD
- h) DMC-FX48PU/GC/GH/GJ

What is the difference is that the "INITIAL SETTINGS" data which is stored in Flash ROM mounted on MAIN PCB.

3.4.1. Defining methods:

To define the model suffix to be serviced, refer to the nameplate which is putted on the bottom side of the Unit.

<p>a) DMC-FX40 (Japan domestic model), DMC-FX40SG The nameplate for these models show the following Safety registration mark.</p> 
<p>b) DMC-FX48P/PC The nameplate for these models show the following Safety registration mark.</p> 
<p>c) DMC-FX40EB/EF/EG/EP The nameplate for these models show the following Safety registration mark.</p> 
<p>d) DMC-FX40EE The nameplate for this model show the following Safety registration mark.</p> 
<p>e) DMC-FX48GT The nameplate for this model show the following Safety registration mark.</p> 
<p>f) DMC-FX48GK The nameplate for this model show the following Safety registration mark.</p> 
<p>g) DMC-FX48GD The nameplate for this model show the following Safety registration mark.</p> 
<p>h) DMC-FX48PU/GC/GH/GJ The nameplate for these models do not show any above Safety registration mark.</p>

NOTE:

After replacing the MAIN PCB, be sure to achieve adjustment.

The adjustment instruction is available at "software download" on the "Support Information from NWBG/VDBG-AVC" web-site in "TSN system", together with Maintenance software.

3.4.2. INITIAL SETTINGS:

After replacing the MAIN PCB, be sure to perform the initial settings after achieving the adjustment by ordering the following procedure in accordance with model suffix of the unit.

1. IMPORTANT NOTICE:

Before proceeding Initial settings, be sure to read the following CAUTIONS.

CAUTION 1:(INITIAL SETTINGS)

---AFTER REPLACING THE MAIN P.C.B. ---

*.The model suffix can be chosen **JUST ONE TIME**.

(Model suffix : "P/EG/EP/PU/GD/GC/GT/GK/EF/EB/EE/PC/GJ/SG/GH and NONE(JAPAN)")

*.Once one of the model suffix has been chosen, the model suffix lists will not be displayed, thus, it can not be changed.

[NOTE:Only for "EG, EP, EF, EB and EE" models]

*.When one of the "EG, EP, EF, EB and EE" has been chosen, only "EG, EP, EF, EB and EE" are displayed from second times.

CAUTION 2:(Stored picture image data in the unit)

This unit employs "Built-in Memory" for picture image data recording.(Approx.40MB)
After proceeding "INITIAL SETTINGS", the picture image data stored in the unit is erased.

2. PROCEDURES:

• Precautions: Read the above "CAUTION 1" and "CAUTION 2", carefully.

• Preparation:

1. Attach the Battery or AC Adaptor with a DC coupler to the unit.

2. Set the recording mode to the [NORMAL PICTURE] mode.

(Press the [MODE] button and select the [NORMAL PICTURE] by pressing the "[UP] and [DOWN] of Cursor buttons", then press the [MENU/SET] button.)

NOTE:

If the unit is other than [NORMAL PICTURE] mode, it does not display the initial settings menu.

• **Step 1. The temporary cancellation of "INITIAL SETTINGS":**

Set the [REC]/[PLAYBACK] selector switch to "[REC] (Camera mark)".

While keep pressing "[UP] of Cursor button" and [DISPLAY] button simultaneously, turn the Power on.

• **Step 2. The cancellation of "INITIAL SETTINGS":**

Set the [REC]/[PLAYBACK] selector switch to "[PLAYBACK]".

Press "[UP] of Cursor button" and [DISPLAY] button simultaneously, then turn the Power off.

• **Step 3. Turn the Power on:**

Set the [REC]/[PLAYBACK] selector switch to "[REC] (Camera mark)", and then turn the Power on.

• **Step 4. Display the INITIAL SETTING:**

NOTE:

If the unit is other than [NORMAL PICTURE] mode, it does not display the initial settings menu.

While keep pressing [MENU/SET] and "[RIGHT] of Cursor buttons" simultaneously, turn the Power off.

The "INITIAL SETTINGS" menu is displayed.

There are two kinds of "INITIAL SETTINGS" menu form as follows:

[CASE 1. After replacing MAIN P.C.B.]

When MAIN P.C.B. has just been replaced, all of the model suffix is displayed as follows. (Four pages in total)

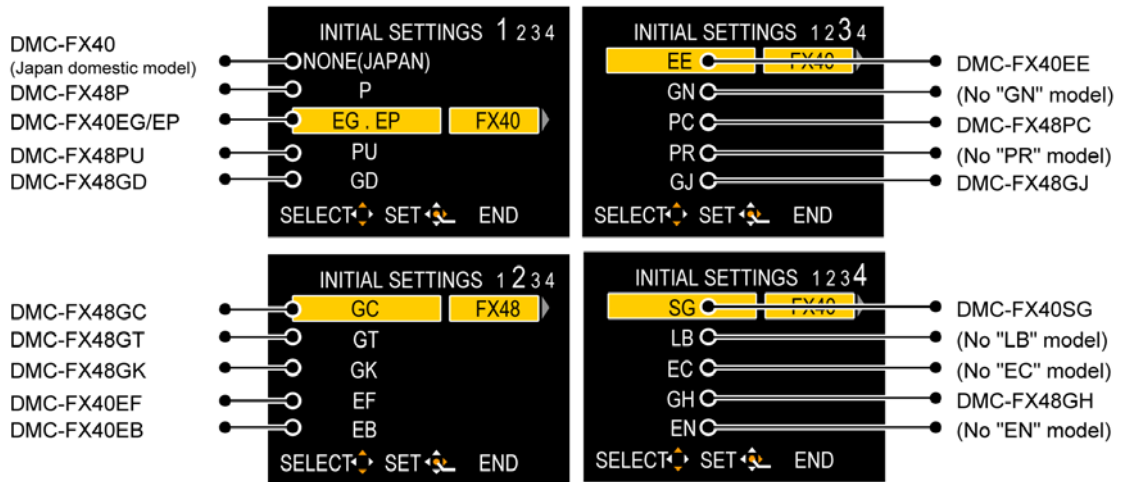

[CASE 2. Other than “After replacing MAIN P.C.B.”]



• **Step 5. Chose the model suffix in “INITIAL SETTINGS”:** (Refer to “CAUTION 1”)

[Caution: After replacing MAIN P.C.B.]

The model suffix can be chosen, **JUST ONE TIME**.

Once one of the model suffix have been chosen, the model suffix lists will not be displayed, thus, it can be changed.

Therefore, select the area carefully.

Select the area with pressing “[UP] / [DOWN] of Cursor buttons”.

• **Step 6. Set the model suffix in “INITIAL SETTINGS”:**

• Press the “[RIGHT] of Cursor buttons”.

• The only set area is displayed, and then press the “[RIGHT] of Cursor buttons” after confirmation.

(The unit is powered off automatically.)

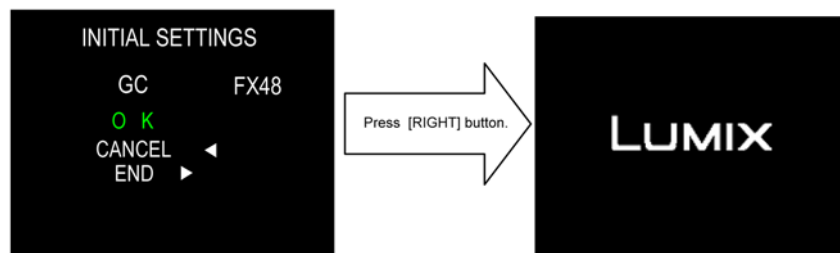

• **Step 7. CONFIRMATION:**

Confirm the display of “PLEASE SET THE CLOCK” in concerned language when the unit is turned on again.
When the unit is connected to PC with USB cable, it is detected as removable media.

1) As for your reference, major default setting condition is as shown in the following table.

• **Default setting (After “INITIAL SETTINGS”)**

	MODEL	VIDEO OUTPUT	LANGUAGE	DATE	REMARKS
a)	DMC-FX40 (Japan domestic model)	NTSC	Japanese	Year/Month/Date	
b)	DMC-FX48P	NTSC	English	Month/Date/Year	
c)	DMC-FX40EG	PAL	English	Date/Month/Year	
d)	DMC-FX40EP	PAL	English	Date/Month/Year	
e)	DMC-FX48PU	NTSC	English	Month/Date/Year	
f)	DMC-FX48GD	NTSC	Korean	Year/Month/Date	
g)	DMC-FX48GC	PAL	English	Date/Month/Year	
h)	DMC-FX48GT	NTSC	Chinese (traditional)	Year/Month/Date	
i)	DMC-FX48GK	PAL	Chinese (simplified)	Year/Month/Date	
j)	DMC-FX40EF	PAL	French	Date/Month/Year	
k)	DMC-FX40EB	PAL	English	Date/Month/Year	
l)	DMC-FX40EE	PAL	Russian	Date/Month/Year	
m)	DMC-FX48PC	NTSC	English	Month/Date/Year	
n)	DMC-FX48GJ	PAL	Thai	Date/Month/Year	
o)	DMC-FX40SG	PAL	English	Date/Month/Year	
p)	DMC-FX48GH	PAL	English	Date/Month/Year	

4 Specifications

Digital Camera: Information for your safety

Power Source:	DC 5.1 V
Power Consumption:	1.3 W (When recording) 0.6 W (When playing back)
Camera effective pixels:	12,100,000 pixels
Image sensor:	1/2.33" CCD, total pixel number 12,700,000 pixels, Primary color filter
Lens:	Optical 5× zoom, f=4.4 mm to 22 mm (35 mm film camera equivalent: 25 mm to 125 mm)/F2.8 to F5.9
Digital zoom:	Max. 4×
Extended optical zoom:	Max. 9.8×
Focus:	Normal/AF Macro/Macro zoom/Face detection/AF Tracking/11-area-focusing/1-area-focusing (High speed)/1-area-focusing/Spot-focusing
Focus range:	Normal: 50 cm (1.64 feet) (Wide)/1 m (3.28 feet) (Tele) to ∞ Macro/Intelligent auto/Clipboard mode: 5 cm (0.17 feet) (Wide)/1 m (3.28 feet) (Tele) to ∞ Scene mode: There may be differences in the above settings. Electronic shutter+Mechanical shutter
Shutter system:	
Motion picture recording:	1280×720 pixels (30 frames/second, only when using a Card)/ 848×480 pixels (30 frames/second, only when using a Card)/ 640×480 pixels (30 frames/second, only when using a Card)/ 320×240 pixels (30 frames/second) With audio
Burst recording	
Burst speed:	Approx. 2.3 pictures/second (Normal), Approx. 1.8 pictures/second (Unlimited)
Number of recordable pictures:	Max. 5 pictures (Standard), max. 3 pictures (Fine), Depends on the remaining capacity of the built-in memory or the card (Unlimited). (Performance in Burst recording is only with SD Memory Card/SDHC Memory Card. MultiMediaCard performance will be less.)
Hi-speed burst	
Burst speed:	Approx. 10 pictures/second(Speed priority) Approx. 6 pictures/second(Image priority) (3M (4:3), 2.5M (3:2) or 2M (16:9) is selected as the picture size.)
Number of recordable pictures:	Approx. 15 to 100
ISO sensitivity:	AUTO/80/100/200/400/800/1600 [HIGH SENS.] mode: 1600 to 6400 8 seconds to 1/2000th of a second [STARRY SKY] mode: 15 seconds, 30 seconds, 60 seconds Auto white balance/Daylight/Cloudy/Shade/Incandescent lights/White set
Shutter speed:	
White balance:	
Exposure (AE):	Program AE Exposure compensation (1/3 EV Step, -2 EV to +2 EV)
Metering mode:	Multiple
LCD monitor:	2.5" TFT LCD (Approx. 230,000 dots) (field of view ratio about 100%) Flash range: [ISO AUTO]
Flash:	Approx. 60 cm (1.97 feet) to 6.0 m (19.7 feet) (Wide) AUTO, AUTO/Red-eye reduction, Forced flash ON (Forced ON/Red-eye reduction), Slow sync./Red-eye reduction, Forced flash OFF

Microphone:	Monaural
Speaker:	Monaural
Recording media:	Built-in Memory (Approx. 40 MB)/SD Memory Card/SDHC Memory Card/MultiMediaCard (Still pictures only)
Picture size	
Still picture:	When the aspect ratio setting is [4:3] 4000×3000 pixels, 3264×2448 pixels, 2560×1920 pixels, 2048×1536 pixels, 1600×1200 pixels, 640×480 pixels When the aspect ratio setting is [3:2] 4000×2672 pixels, 3264×2176 pixels, 2560×1712 pixels, 2048×1360 pixels When the aspect ratio setting is [16:9] 4000×2248 pixels, 3264×1840 pixels, 2560×1440 pixels, 1920×1080 pixels
Motion pictures:	1280×720 pixels (Only when using a Card)/ 848×480 pixels (Only when using a Card)/ 640×480 pixels (Only when using a Card)/ 320×240 pixels Fine/Standard
Quality:	
Recording file format	
Still Picture:	JPEG (based on "Design rule for Camera File system", based on "Exif 2.21" standard)/DPOF corresponding
Pictures with audio:	JPEG (based on "Design rule for Camera File system", based on "Exif 2.21" standard)+ "QuickTime" (pictures with audio)
Motion pictures:	"QuickTime Motion JPEG" (motion pictures with audio)
Interface	
Digital:	"USB 2.0" (High Speed)
Analog video/audio:	NTSC, Component Audio line output (monaural)
Terminal	
[COMPONENT OUT]:	Dedicated jack (10 pin)
[AV OUT/DIGITAL]:	Dedicated jack (8 pin)
Dimensions:	Approx. 95.3 mm (W)×52.9 mm (H)×21.5 mm (D) [3 3/4" (W)×2 1/16" (H)×7/8" (D)] (excluding the projecting parts)
Mass(weight)	Approx. 128 g/4.51 oz (excluding card and battery) Approx. 150 g/5.29 oz (with card and battery)
Operating temperature:	0°C to 40 °C (32 °F to 104 °F)
Operating humidity:	10% to 80%
Language select:	[ENGLISH]/[ESPAÑOL] (DMC-FX48P) [ENGLISH]/[DEUTSCH]/[FRANÇAIS]/[ESPAÑOL]/[ITALIANO]/ [繁體中文]/[日本語] (DMC-FX48PC)
Battery Charger	
(Panasonic DE-A59B):	Information for your safety
Input:	110 V to 240 V~50/60 Hz, 0.2 A
Output:	CHARGE 4.2 V=0.65 A
Equipment mobility:	Transportable
Battery Pack (lithium-ion)	
(Panasonic DMW-BCF10PP):	Information for your safety
Voltage/capacity (Minimum):	3.6 V/940 mAh

NOTE:(Only for "EB/EF/EG/EP" models)

- Data from the PC can not be written to the camera using the USB connection cable.
- Motion pictures can be recorded continuously for up to 15 minutes.
The maximum continuous recording time (up to 15 minutes) is displayed on the screen.

5 Location of Controls and Components

Names of the Components

- 1 Flash
- 2 Lens
- 3 Self-timer indicator
AF assist lamp

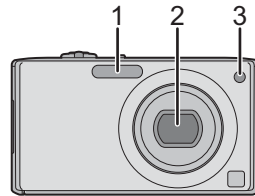

- 4 LCD monitor
- 5 Status indicator
- 6 [MENU/SET] button
- 7 [DISPLAY] button
- 8 [Q.MENU] /Delete button
- 9 [REC]/[PLAYBACK] selector switch

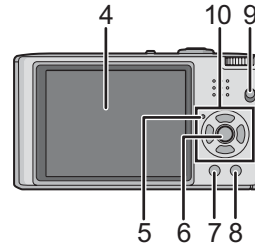

- 10 Cursor buttons

- (A): ▲/Exposure compensation/
Auto bracket /White balance
fine adjustment
- (B): ▼/Macro mode
AF Tracking
- (C): ◀/Self-timer button
- (D): ▶/Flash setting button

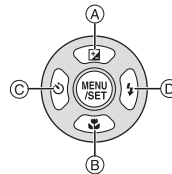

- 11 Camera ON/OFF switch
- 12 Zoom lever
- 13 Speaker
- 14 Microphone
- 15 Shutter button
- 16 Mode dial

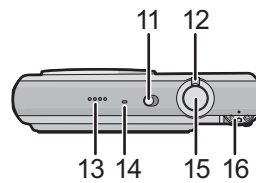

- 17 Hand strap eyelet
• Be sure to attach the hand strap when using the camera to ensure that you will not drop it.
- 18 Lens barrel
- 19 [COMPONENT OUT] socket
- 20 [AV OUT/DIGITAL] socket

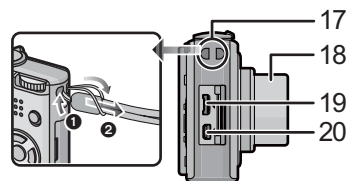

- 21 Tripod receptacle
• When you use a tripod, make sure the tripod is stable when the camera is attached to it.
- 22 Card/Battery door
- 23 Release lever
- 24 DC coupler cover
• When using an AC adaptor, ensure that the Panasonic DC coupler (DMW-DCC4; optional) and AC adaptor (DMW-AC5PP; optional) are used.

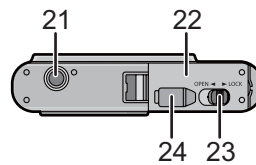

Selecting the [REC] Mode

When the [REC] mode is selected, the camera can be set to the Intelligent auto mode in which the optimal settings are established in line with the subject to be recorded and the recording conditions, or to the Scene mode which enables you to take pictures that match the scene being recorded.

- 1 Turn the camera on.**
 - Ⓐ [REC]/[PLAYBACK] selector switch
 - Ⓑ Mode dial
- 2 Slide the [REC]/[PLAYBACK] selector switch to [ON].**
- 3 Switching the mode by rotating the mode dial.**

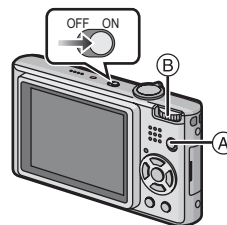

Align a desired mode with part Ⓒ.

- Rotate the mode dial slowly and surely to adjust to each mode. (The part where there is no mode will not turn.)

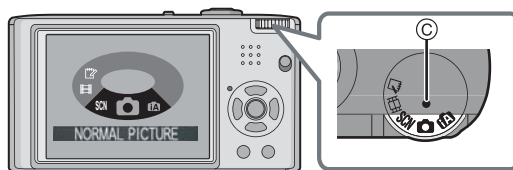

List of [REC] modes

Intelligent auto mode

The subjects are recorded using settings automatically selected by the camera.

Normal picture mode

The subjects are recorded using your own settings.

Scene mode

This allows you to take pictures that match the scene being recorded.

Motion picture mode

This mode allows you to record motion pictures with audio.

Clipboard mode

Record as a memo.

About the Battery

- This unit has a function that can distinguish useable batteries. Exclusive batteries are supported by this function. (Conventional batteries not supported by this function cannot be used.)

It has been found that counterfeit battery packs which look very similar to the genuine product are made available to purchase in some markets. Some of these battery packs are not adequately protected with internal protection to meet the requirements of appropriate safety standards. There is a possibility that these battery packs may lead to fire or explosion. Please be advised that we are not liable for any accident or failure occurring as a result of use of a counterfeit battery pack. To ensure that safe products are used we would recommend that a genuine Panasonic battery pack is used.

6 Service Mode

6.1. Error Code Memory Function

1. General description

This unit is equipped with history of error code memory function, and can be memorized 16 error codes in sequence from the latest. When the error is occurred more than 16, the oldest error is overwritten in sequence.

The error code is not memorized when the power supply is shut down forcibly (i.e., when the unit is powered on by the battery, the battery is pulled out) The error code is memorized to FLASH ROM when the unit has just before powered off.

2. How to display

The error code can be displayed by ordering the following procedure:

• Preparation:

1. Attach the Battery or AC Adaptor with a DC coupler to the unit.

NOTE:

*Since this unit has built-in memory, it can be performed without inserting SD memory card.

*Set the mode dial other than "CLIPBOARD (memo)" mode (such as "normal picture/ iA / scene mode) to display the error code.

• Step 1. The temporary cancellation of "INITIAL SETTINGS":

Set the [REC]/[PLAYBACK] selector switch to "[REC] (Camera mark)".

While keep pressing "[UP] of Cursor button" and [DISPLAY] button simultaneously, turn the Power on.

• Step 2. Execute the error code display mode:

Press the "[LEFT] of Cursor button", [MENU/SET] button and [DISPLAY] button simultaneously.

The display is changed as shown below when the above buttons are pressed simultaneously.

Normal display → Error code display → Operation history display → Normal display →

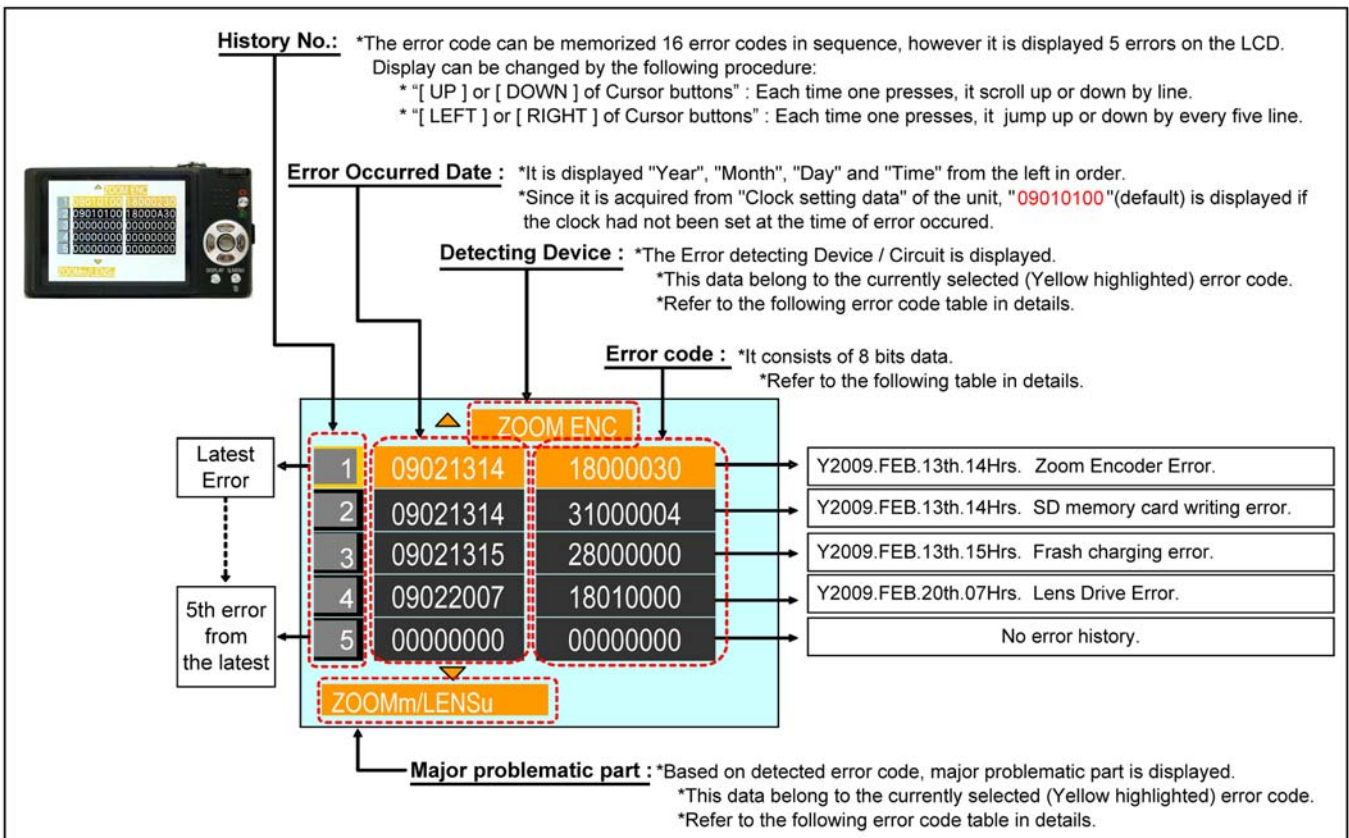

Example of Error Code Display

• 3. Error Code List

The error code consists of 8 bits data and it shows the following information.

Attribute	Main item	Sub item	Error code		Contents (Upper line)	Error Indication							
			High 4 bits	Low 4 bits	Problematic Part & Check point (Lower line)	Detecting device	Problematic Part/Circuit						
LENS	Lens drive	OIS	18*0	1000	PSD (X) error. Hall element (X axis) position detect error in OIS unit. OIS Unit	OIS X	LENSu NG						
				2000	PSD (Y) error. Hall element (Y axis) position detect error in OIS unit. OIS Unit	OIS Y							
				3000	GYRO (X) error. Gyro (IC7101: X axis) detect error on Main P.C.B.. IC7101 (Gyro element) or IC6001 (VENUS 5)	JYRO X	JYRO NG						
				4000	GYRO (Y) error. Gyro (IC7101: Y axis) detect error on Main P.C.B.. IC7101 (Gyro element) or IC6001 (VENUS 5)	JYRO Y							
				5000	MREF error (Reference voltage error). IC9101 (SYSTEM) or IC6001 (VENUS 5)	OIS REF	LENSsd/DSP NG						
				6000	Drive voltage (X) error. LENS Unit, LENS flex breaks, IC6001 (VENUS 5) AD value error, etc.	OISX REF							
				7000	Drive voltage (Y) error. LENS Unit, LENS flex breaks, IC6001 (VENUS 5) AD value error, etc.	OISY REF	LENSu/LENS FPC						
				Zoom (C.B.)	0?10	Collapsible barrel Low detect error (Collapsible barrel encoder always detects Low.) Mechanical lock, FP9002-(3) signal line or IC6001 (VENUS 5)		ZOOM L	ZOOMm/LENSu				
					0?20	Collapsible barrel High detect error (Collapsible barrel encoder always detects High.) Mechanical lock, FP9002-(3) signal line or IC6001 (VENUS 5)	ZOOM H						
					0?30	Zoom motor sensor error. Mechanical lock, FP9002-(35), (38) signal line or IC6001 (VENUS 5)	ZOOM ENC						
		0?40	Zoom motor sensor error. (During monitor mode.) Mechanical lock, FP9002-(35), (38) signal line or IC6001 (VENUS 5)										
		0?50	Zoom motor sensor error. (During monitor mode with slow speed.) Mechanical lock, FP9002-(35), (38) signal line or IC6001 (VENUS 5)										
		Focus	0?01		HP High detect error (Focus encoder always detects High, and not becomes Low) Mechanical lock, FP9002-(3) signal line or IC6001 (VENUS 5)	FOCUS L	LENS FPC/DSP						
			0?02	HP Low detect error (Focus encoder always detects Low, and not becomes High) Mechanical lock, FP9002-(3) signal line or IC6001 (VENUS 5)	FOCUS H								
		Lens		18*1	0000	Power ON time out error. Lens drive system	LENS DRV	LENSu					
					0000	Power OFF time out error. Lens drive system							
		Adj. History	OIS	19*0	2000	OIS adj. Yaw direction amplitude error (small)	OIS ADJ	OIS ADJ					
					3000	OIS adj. Pitch direction amplitude error (small)							
					4000	OIS adj. Yaw direction amplitude error (large)							
					5000	OIS adj. Pitch direction amplitude error (large)							
	6000				OIS adj. MREF error								
	7000				OIS adj. time out error								
	8000				OIS adj. Yaw direction off set error								
	9000				OIS adj. Pitch direction off set error								
	A000				OIS adj. Yaw direction gain error								
	B000				OIS adj. Pitch direction gain error								
	C000				OIS adj. Yaw direction position sensor error								
	D000				OIS adj. Pitch direction position sensor error								
	E000				OIS adj. other error								
	HARD				VENUS A/D	Flash			28*0	0000	Flash charging error. IC6001-(AC17) signal line or Flash charging circuit	STRB CHG	STRB PCB/FPC
					FLASH ROM (EEPROM Area)	FLASH ROM (EEPROM Area)			2B*0	0001	EEPROM read error	FROM RE	FROM
										0003	IC6002 (FLASH ROM)	FROM WR	FROM
0004		EEPROM write error IC6002 (FLASH ROM)											
0002		Firmware version up error Replace the firmware file in the SD memory card.	(No indication)	(No indication)									
0005		SDRAM error SDRAM Mounting defective											
SYSTEM		RTC	2C*0	0001	SYSTEM IC initialize failure error Communication between IC6001 (VENUS 5) and IC9101 (SYSTEM)	SYS INIT	MAIN PCB						
				SOFT	CPU	Reset	30*0	0001	NMI reset Non Mask-able Interrupt (30000001-30000007 are caused by factors)	NMI RST	MAIN PCB		
Card		Card	31*0	0001				Card logic error SD memory card data line or IC6001 (VENUS 5)	SD CARD	SD CARD/DSP			
				0002	Card physical error SD memory card data line or IC6001 (VENUS 5)								
	0004			Write error SD memory card data line or IC6001 (VENUS 5)	SD WRITE								
	0005			Format error	INMEMORY	FROM							
	0001			Camera task finish process time out. Communication between Lens system and IC6001 (VENUS 5)	LENS COM	LENSu/DSP							
CPU. ASIC	Stop	38*0	0002	Camera task invalid code error. IC6001 (VENUS 5)	DSP	DSP							
			0100	File time out error in recording motion image IC6001 (VENUS 5)									
			0200	File data cue send error in recording motion image IC6001 (VENUS 5)									
			0300	Single or burst recording brake time out.									
			Memory area	3A*0			0008	USB work area partitioning failure USB dynamic memory securing failure when connecting	(No indication)	(No indication)			
							Operation Zoom	Power on Zoom	3B*0	0000	FLASHROM processing early period of camera during movement.	INIT	(No indication)
Zoom	Zoom	3C*0	0000	Imperfect zoom lens processing Zoom lens	ZOOM	ZOOMm/LENSu							
			35*0	0000	Software error (0-7bit : command, 8-15bit : status)	DSP	DSP						
			FFFF										
			35*1	0000	Though record preprocessing is necessary, it is not called.								
			35*2	0000	Though record preprocessing is necessary, it is not completed.	(No indication)	(No indication)						

Important notice about "Error Code List"

1) About "*" indication:

The third digit from the left is different as follows.

- In case of 0 (example: 1801000)

When the third digit from the left shows "0", this error occurred under the condition of INITIAL SETTINGS has been completed.

It means that this error is occurred basically at user side.

- In case of 8 (example: 1881000)

When the third digit from the left shows "8", this error occurred under the condition of INITIAL SETTINGS has been released.

(Example; Factory assembling-line before unit shipment, Service mode etc.)

It means that this error is occurred at service side.

2) About "?" indication: ("18*0 0?01" to "18*0 0?50"):

The third digit from the right shows one of the hexadecimal ("0" to "F") character.

• 4. How to exit from Error Code display mode:

Simply, turn the power off. (Since Error code display mode is executed under the condition of temporary cancellation of "INITIAL SETTINGS", it wake up with normal condition when turn off the power.)

NOTE:

The error code can not be initialized.

6.2. ICS (Indication of additional Camera Settings when picture was taken) function

1. General description

This unit is equipped with ICS (ICS: Indication of additional Camera Settings when picture was taken) function by playing back the concerned picture on the LCD display.

(This function is achieved by utilizing "maker note" data stored in Exif data area of recorded picture file.)

To proceed failure diagnosis, use this ICS function together with "displaying the recorded picture with picture information" function.

NOTE:

- The ICS function operates with a picture which is only taken with the same model. (It may not be displayed when the picture was taken with other model.)
- Since Exif data is not available after the picture is edited by PC, the ICS function may not be activated.

2. How to display

The ICS data is displayed by ordering the following procedure:

• Preparation:

1. Attach the Battery or AC Adaptor with a DC coupler to the unit.

NOTE:

Set the mode dial other than "CLIPBOARD (memo)" mode (such as Normal picture/ iA / Scene) to display the ICS data.

• Step 1. The temporary cancellation of "INITIAL SETTINGS":

Set the [REC]/[PLAYBACK] selector switch to "[REC] (Camera mark)".

While keep pressing "[UP] of Cursor button" and [DISPLAY] button simultaneously, turn the Power on.

• Step 2. Execute the ICS display mode:

Set the [REC]/[PLAYBACK] selector switch to [PLAYBACK].

Select the concerned picture by pressing the "[LEFT] and [RIGHT] of Cursor button".

Press the "[LEFT] of Cursor button", [MENU/SET] button and [DISPLAY] button simultaneously.

Press the [DISPLAY] button, 3 times.

The display condition is changed as shown below when the [DISPLAY] button is pressed.

Code display → Code + Picture display (1) → Code + Picture display (2) → ICS display → Code display

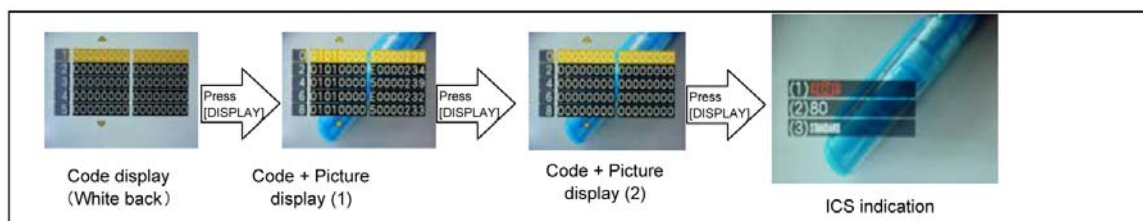

3. How to read

(1). Jitter alert was displayed or not:
 This part shows that the "Jitter alert" mark was displayed or not when the picture has just before been taken.
 +.With "Jitter alert" mark : The "Jitter alert" mark was displayed.
 +.Without "Jitter alert" mark: The "Jitter alert" mark was not displayed.
 [About "Jitter alert" mark]
 Due to lacking the enough light amount etc, shooting condition prone to make a "hand jitter", the "Jitter alert" mark is displayed.
 [Reference Guide]
 (Applicable settings : Normal picture mode, ISO100, WIDE edge, Flash OFF)
 +.The "Jitter alert" mark is displayed when the shutter speed is 1/15th and below.

(2). ISO Sensitivity Setting condition:
 This part shows that the "ISO Sensitivity" setting condition when the picture had been taken.
 (Note: The [i ISO] is displayed when the "Intelligent ISO " was selected.)
 For instance, when the recorded picture information shows [ISO80], it can be confirmed the ISO setting condition ; [AUTO], [INTELLIGENT ISO] or [ISO 80](Fixed: set by user).
 [Point for Confirmation]
 *The symptom is "Picture with "hand jitter". Subject is not clearly stopped." in darker scene, does the picture was taken with lower ISO setting mode?
 *The symptom is "Noisy picture. Rough picture image" in brighter scene, does the picture was taken with higher ISO setting mode?

(3). Color mode Setting condition:
 This part shows that the "Color mode" setting condition when the picture had been taken.
 [Point for Confirmation]
 *The symptom is "Color is strange. The picture is bluish (Yellowish) ", does the picture was taken with [SEPIA] / [COOL] / [WARM] settings?
 NOTE: As for the symptom related with the color, confirm the picture information which is displayed in normal playback screen as well.
 (In normal playback screen, the setting condition of "White balance" and "WB Adjustment "can be confirmed.)

Normal playback screen
 (Recorded picture with information)



*In playback mode, the picture information is displayed when pressing the [DISPLAY] button. (It can be confirmed at user as well.)
 *Use this indication together with ICS function.

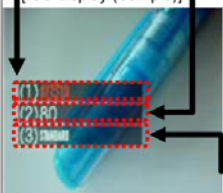

[ICS display (Sample)]

(1). Jitter alert mark : [Indicated]
 (2). ISO sens. setting : ISO80 (Fixed)
 (3). Color mode setting: Standard

[Reference Guide : Settings "When taking picture"]

<ISO SENSITIVITY>
 *This allows the sensitivity to light (ISO sensitivity) to be set. Setting to a higher figure enables pictures to be taken even in dark places without the resulting pictures coming out dark.
 *In this unit, it can be set one of the [AUTO], [80], [100], [200], [400], [800] and [1600] in "Normal shooting" mode.
 (The ISO sensitivity setting is not available when the [INTELLIGENT ISO] is being used.)
 *When setting to [AUTO], the ISO sensitivity is automatically adjusted to a maximum of [ISO400] according to the brightness.
 (It can be adjusted to a maximum of [ISO1000] when using the flash.)
 *To avoid picture noise, we recommend that you either reduce the ISO sensitivity level or set [COLOR MODE] to [NATURAL], and then take pictures.

ISO sensitivity	80	↔	1600
Recording location (recommended)	When it is light (outdoors)		When it is dark
Shutter speed	Slow		Fast
Noise	Less		Increased

<COLOR MODE>
 *Using these modes, the pictures can be made sharper or softer, the colors of the pictures can be turned into sepia colors or other color effects can be achieved.
 *In this unit, it can be set one of the following effects in "Normal shooting" mode.

[STANDARD] : This is the standard setting.	[B/W] : The picture becomes black and white.
[NATURAL] : The picture becomes softer.	[SEPIA] : The picture becomes sepia.
[VIVID] : The picture becomes sharper.	[COOL] : The picture becomes bluish.
	[WARM] : The picture becomes reddish.

NOTE: You cannot set [NATURAL], [VIVID], [COOL] or [WARM] in Intelligent auto mode.

*When you take pictures in dark places, noise may become visible. To avoid noise, we recommend setting to [NATURAL].





4. How to exit:

Simply, turn the power off. (Since ICS function is executed under the condition of temporary cancellation of "INITIAL SETTINGS", it wake up with normal condition when turn off the power.)

7 Service Fixture & Tools

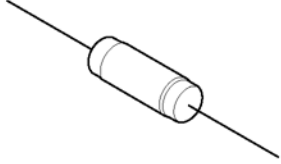
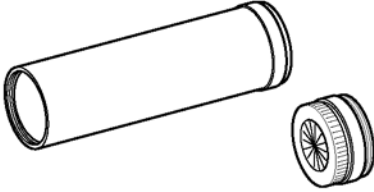
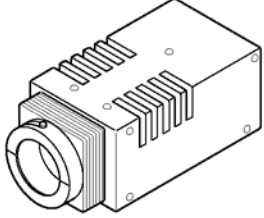
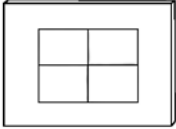
7.1. Service Fixture and Tools

The following Service Fixture and tools are used for checking and servicing this unit.

Resistor for Discharging ERG5SJ102	Infinity Lens (with Focus Chart) VFK1164TCM02	LIGHT BOX VFK1164TDVLB
 <p>An equivalent type of Resistor may be used.</p>	 <p>* RFKZ0422 can be used.</p>	 <p>※ with DC Cable</p>
TR Chart RFKZ0443	Lens Cleaning Kit (BK) VFK1900BK	Grease (for lens) RFKZ0472
	 <p>* Only supplied as 10 set/box.</p>	
Driver (for mode dial installation screw) VFK1390		
		

7.2. When Replacing the Main PCB

After replacing the MAIN PCB, be sure to achieve adjustment.

The adjustment instruction is available at "software download" on the "Support Information from NDBG/VDBG-AVC" web-site in "TSN system", together with Maintenance software.

7.3. Service Position

This Service Position is used for checking and replacing parts. Use the following Extension cables for servicing.

Table S1 Extension Cable List

No.	Parts No.	Connection	Form
1	RFKZ0477	FP9002 (MAIN) - LENS UNIT	45PIN 0.3 FFC
2	RFKZ0416	FP9001 (MAIN) - CCD UNIT	41PIN 0.3 FFC
3	VFK1951	FP9003 (MAIN) - LCD UNIT	39PIN 0.3 FFC
4	VFK1974	FP9004 (MAIN) - LCD UNIT	4PIN 0.5 FFC
5	RFKZ0525	PP9001 (MAIN) - PS9801 (SUB)	60PIN B to B
6	RFKZ0418	PP9802 (SUB) - PS8001 (FLASH TOP)	30PIN B to B

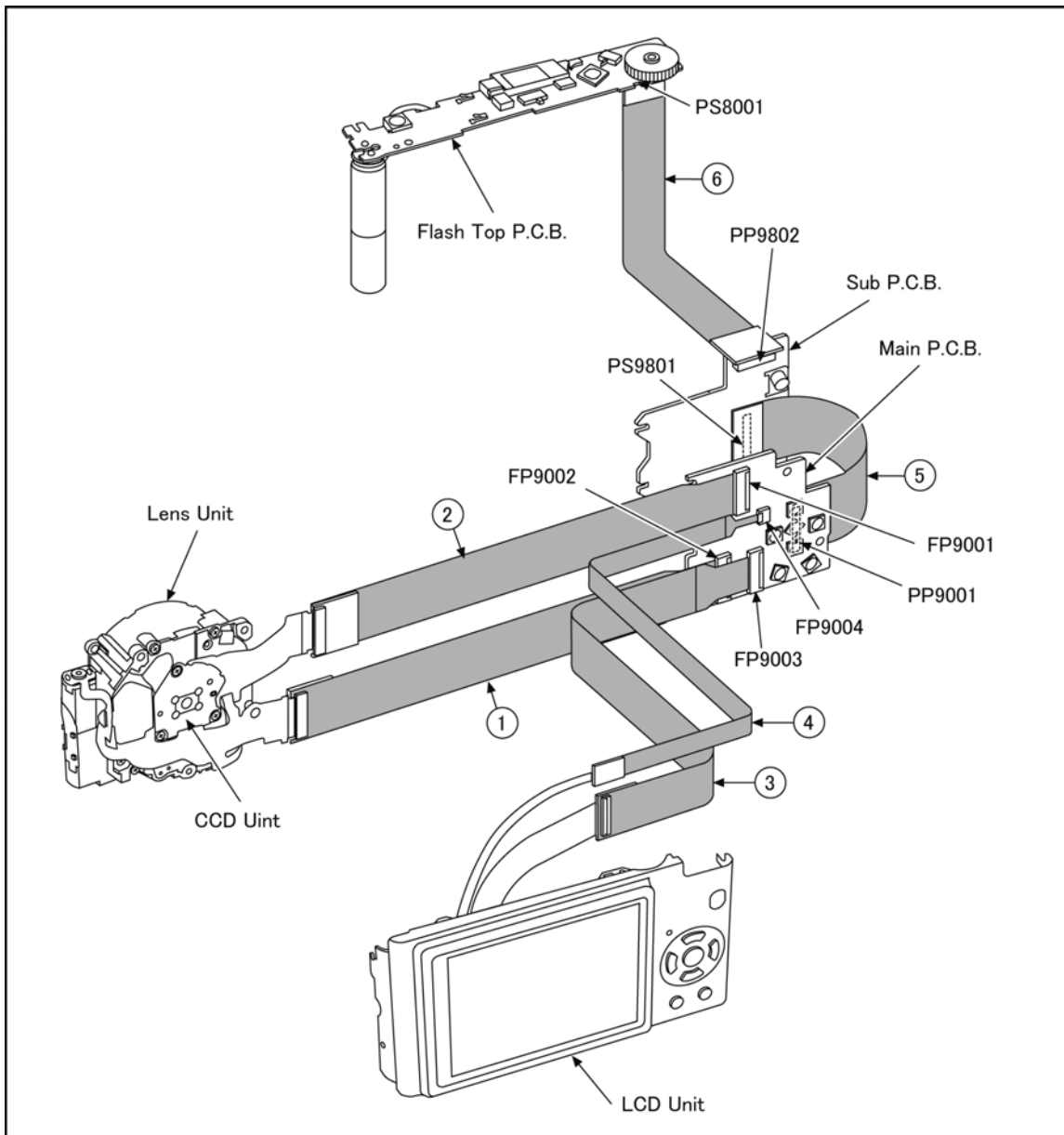

CAUTION-1. (When servicing FLASH TOP PCB)

1. Be sure to discharge the capacitor on FLASH TOP PCB.
Refer to "HOW TO DISCHARGE THE CAPACITOR ON FLASH TOP PCB".
The capacitor voltage is not lowered soon even if the AC Cord is unplugged or the battery is removed.
2. Be careful of the high voltage circuit on FLASH TOP PCB.
3. DO NOT allow other parts to touch the high voltage circuit on FLASH TOP PCB.

8 Disassembly and Assembly Instructions

8.1. Disassembly Flow Chart

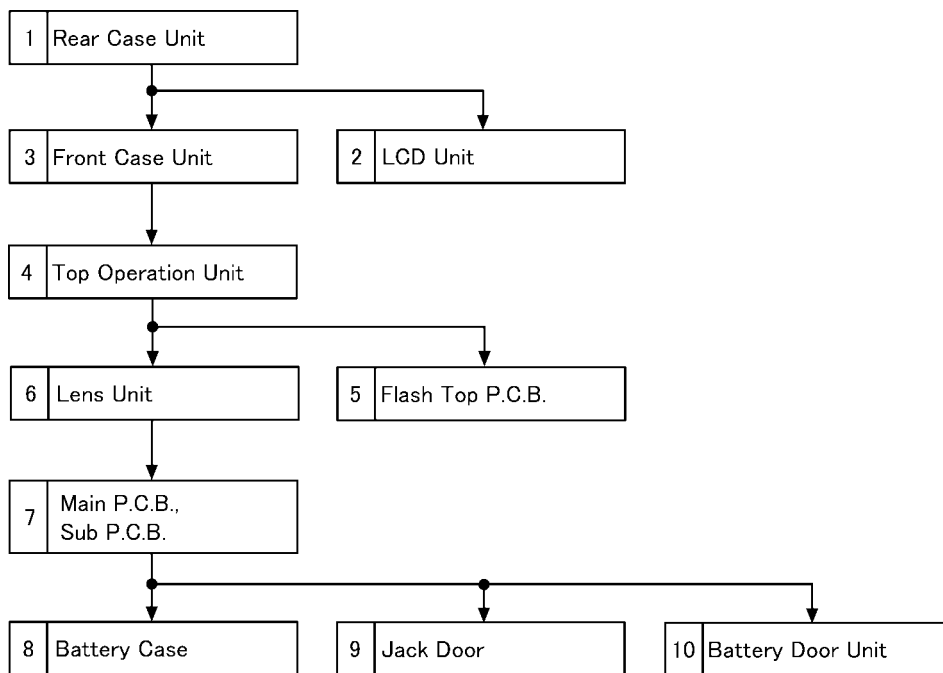

8.2. PCB Location

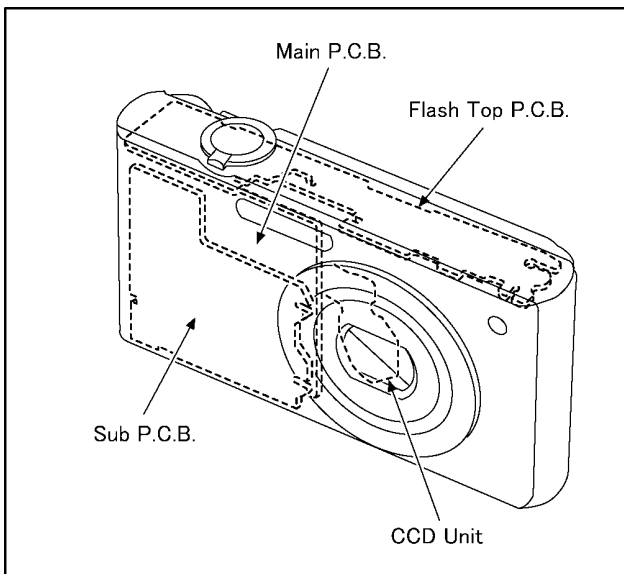

8.3. Disassembly Procedure

No.	Item	Fig	Removal
1	Rear Case Unit	(Fig.D1)	Card
			Battery
			1 Screw (A)
			4 Screws (B)
			Side Ornament (L)
		Side Ornament (R)	
		(Fig.D2)	1 Lock (A)
			1 Lock (B)
			FP9003(Flex)
			FP9004(Flex)
Rear Case Unit			
2	LCD Unit	(Fig.D3)	4 Locking tabs LCD Unit
3	Front Case Unit	(Fig.D4)	2 Locking tabs Front Case Unit
4	Top Operation Unit	(Fig.D5)	PS8001(Connector) Top Operation Unit
5	Flash Top P.C.B.	(Fig.D6)	AF Panel Light
			2 Screws (C)
			6 Locking tabs
		Flash Top P.C.B.	
(Fig.D7)	NOTE: (When installing)		
6	Lens Unit	(Fig.D8)	3 Screws (D)
			Rear Plate
			Tripod Fixing Plate
			FP9001(Flex)
			FP9002(Flex)
			Lens Unit
			7
PP9001(Connector)			
3 Locking tabs			
PCB Spacer			
Slide Knob			
Main P.C.B.			
Sub P.C.B.			
8	Battery Case	(Fig.D10)	
			Battery Out Spring
			Battery Case
9	Jack Door	(Fig.D11)	Jack Door Shaft
			Jack Door
10	Battery Door Unit	(Fig.D12)	Battery Door Shaft
			Battery Door Spring
			Battery Door Unit

8.3.1. Removal of the Rear Case Unit

NOTE:

When servicing and reassembling, remove the card and battery from the unit.

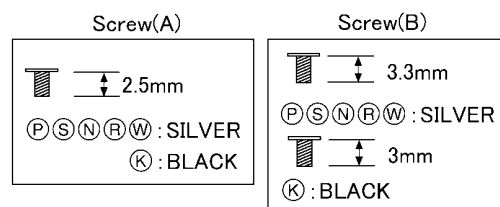
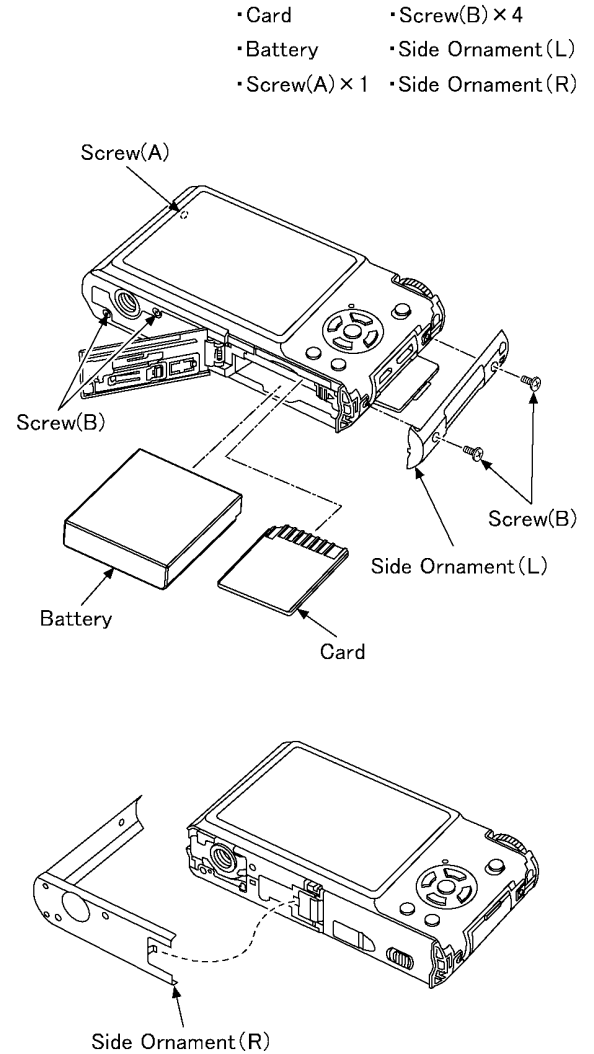

(Fig.D1)

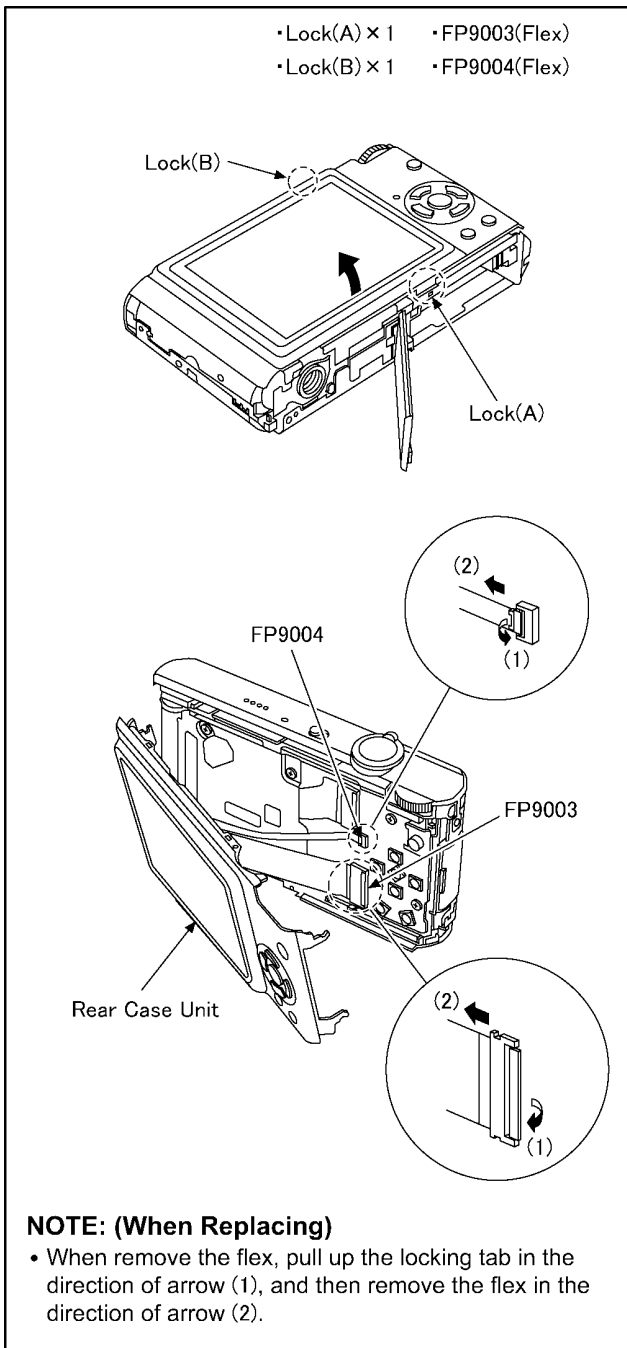

(Fig.D2)

8.3.2. Removal of the LCD Unit

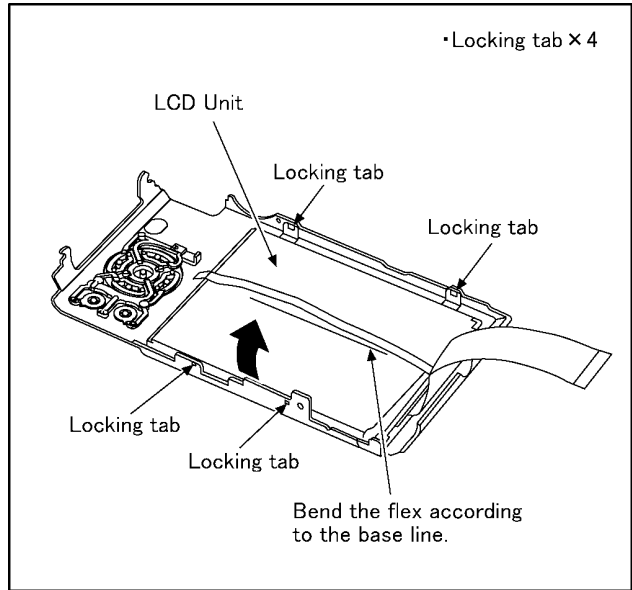

(Fig.D3)

8.3.3. Removal of the Front Case Unit

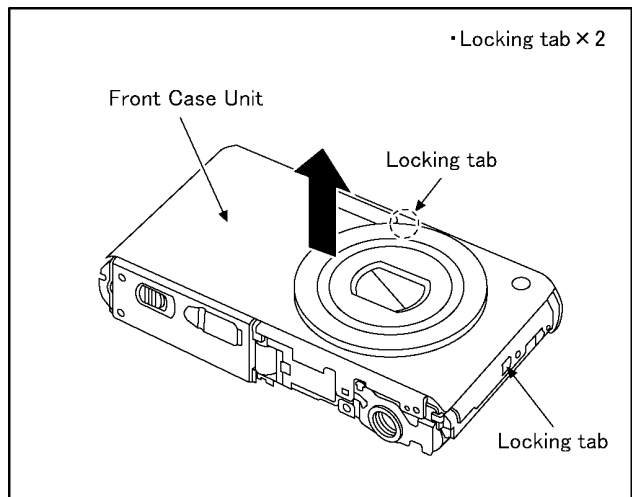

(Fig.D4)

8.3.4. Removal of the Top Operation Unit

IMPORTANT NOTICE:

Take care not apply any bending load to the charging capacitor. It brings about the possibility of PCB and/or component damage on the Flash Top P.C.B.

•PS8001(Connector)

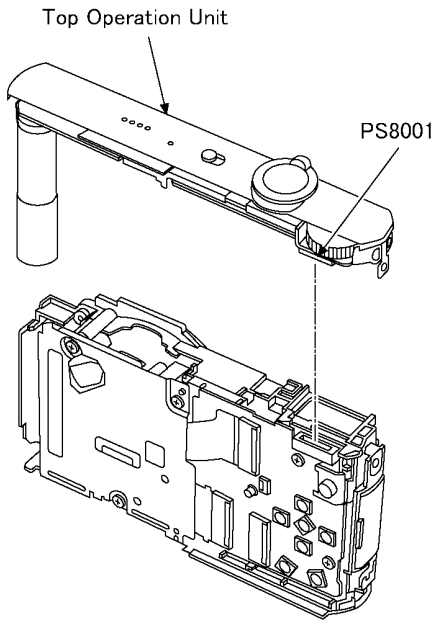

(Fig.D5)

IMPORTANT NOTICE:

Take care not apply any bending load to the charging capacitor. It brings about the possibility of PCB and/or component damage on the Flash Top P.C.B.

NOTE: (When Installing)

• Align the convex of power switch and power knob.

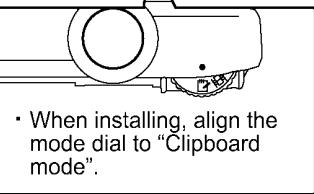
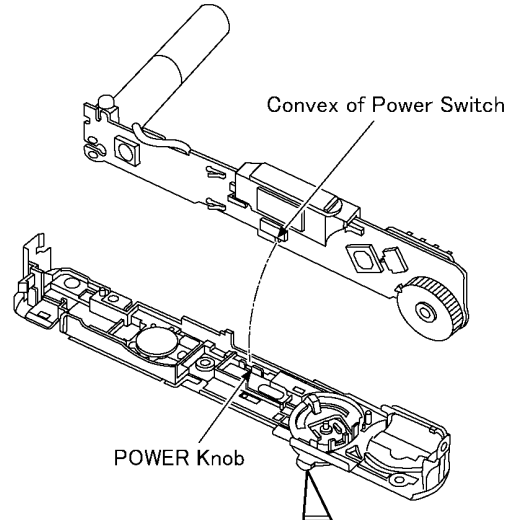

• When installing, align the mode dial to "Clipboard mode".

8.3.5. Removal of the Flash Top P.C.B.

• AF Panel Light •Screw(C) × 2
• Locking tab × 6

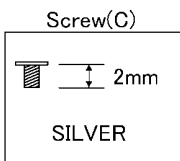
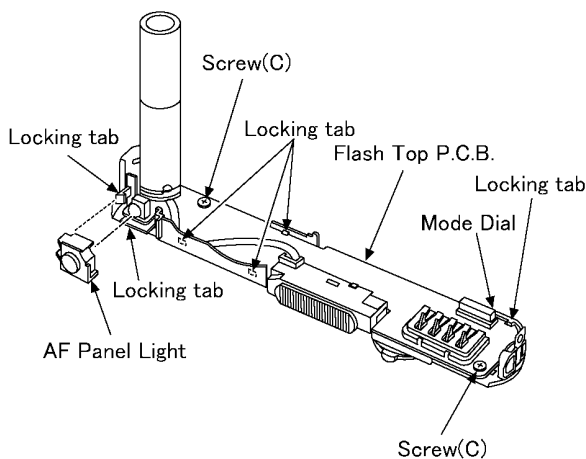

NOTE: (When Replacing)

• When remove the Flash Top P.C.B., align the mode deal to "Clipboard mode".

(Fig.D6)

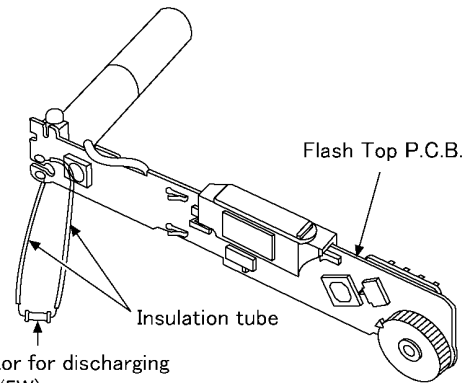

CAUTION

Be sure to discharge the capacitor on Flash Top P.C.B. before disassembling.

1. Remove the Flash Top P.C.B..
2. Put the insulation tube on the lead part of resistor (ERG5SJ102: 1kΩ/5W).
3. Put the resistor between both terminals of capacitor unit for approx. 5 seconds.

(Fig.D7)

8.3.6. Removal of the Lens Unit

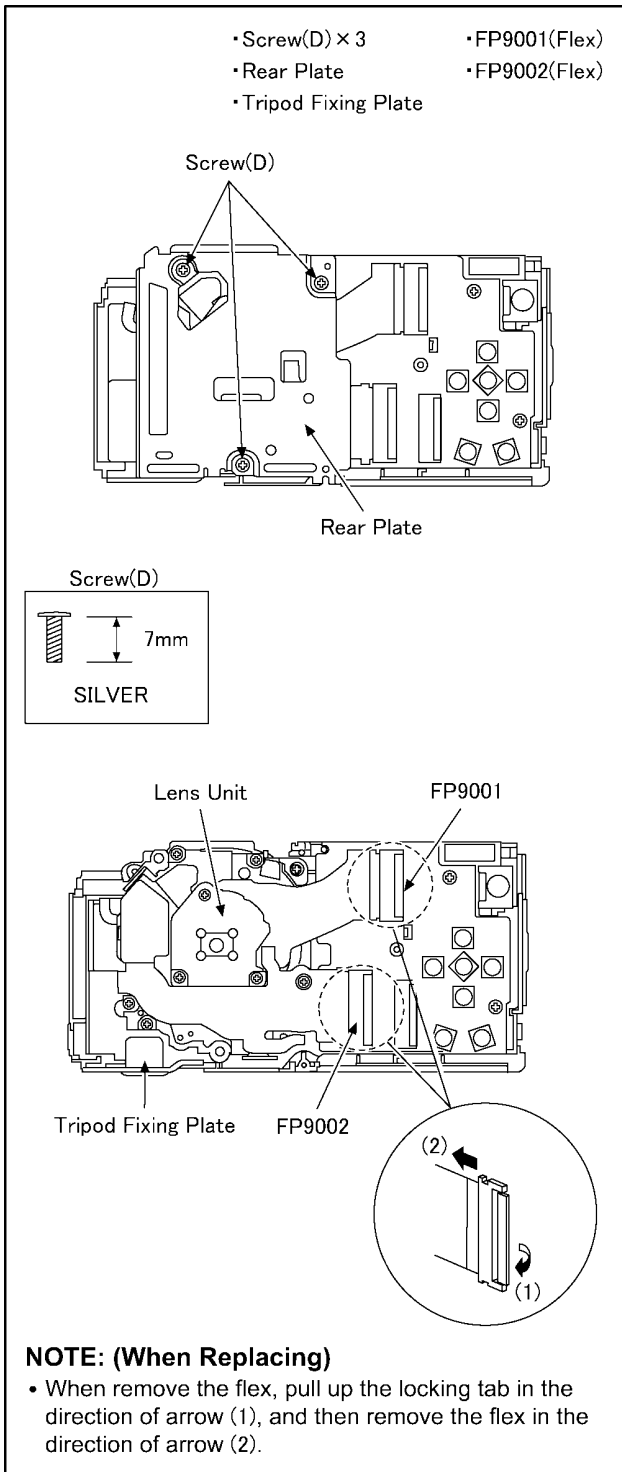

(Fig.D8)

8.3.7. Removal of the Main P.C.B. and Sub P.C.B.

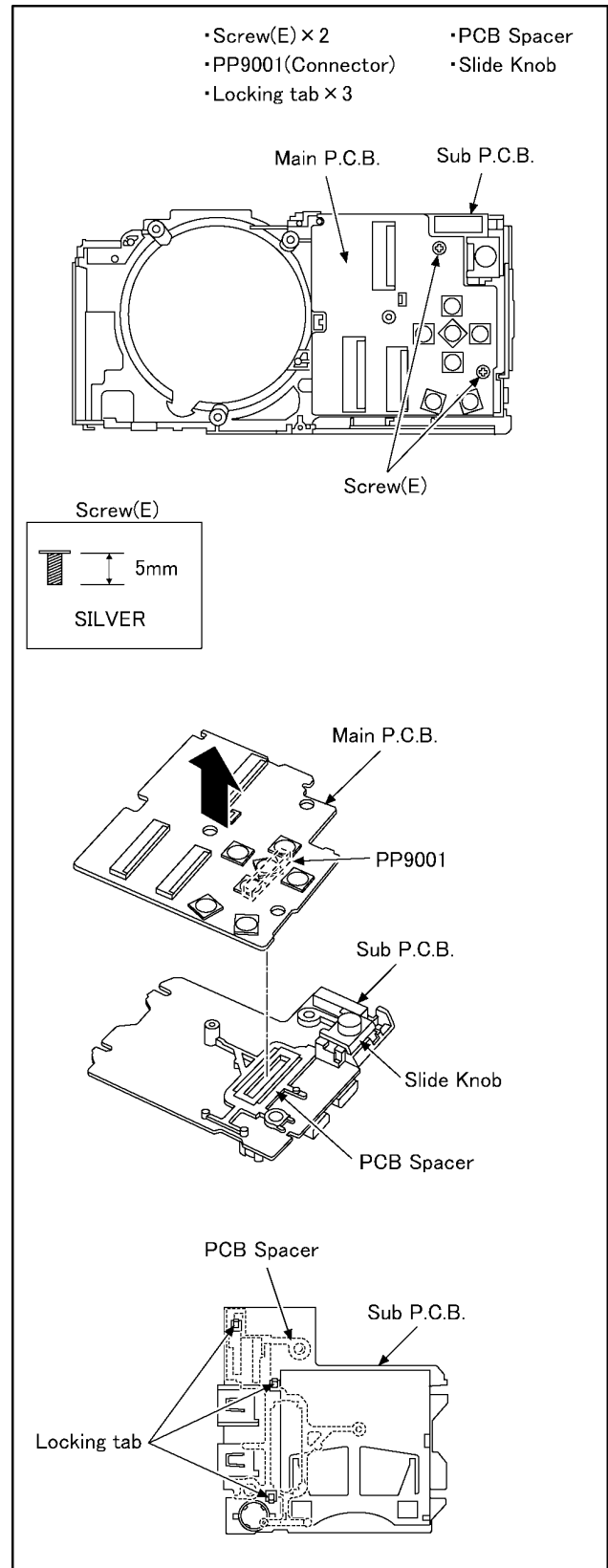

(Fig.D9)

8.3.8. Removal of the Battery Case

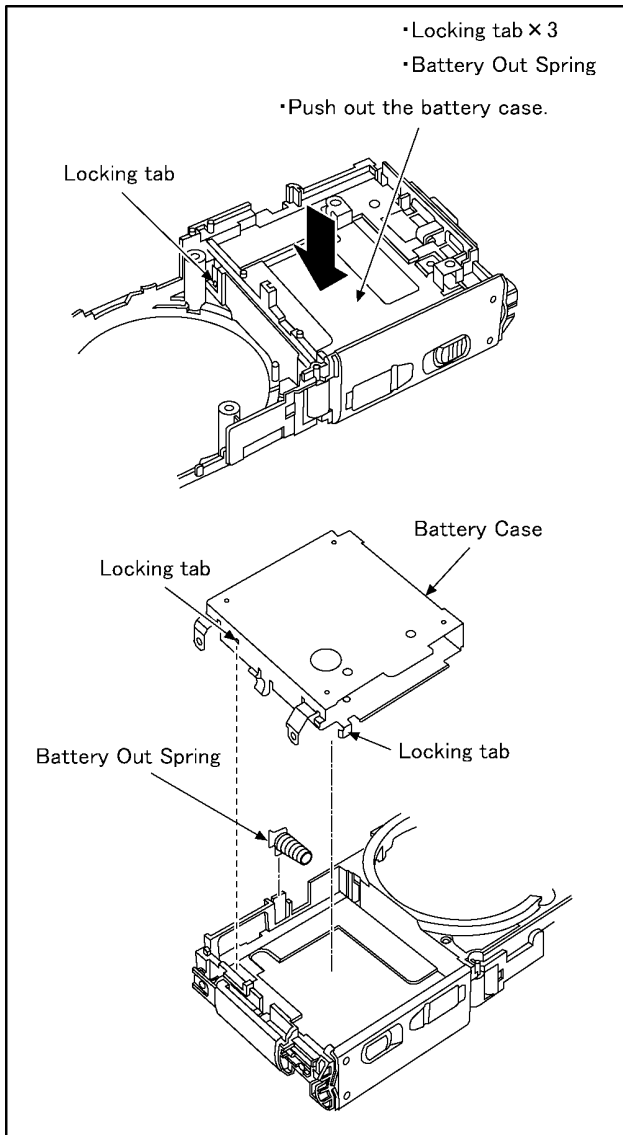

(Fig.D10)

8.3.9. Removal of the Jack Door

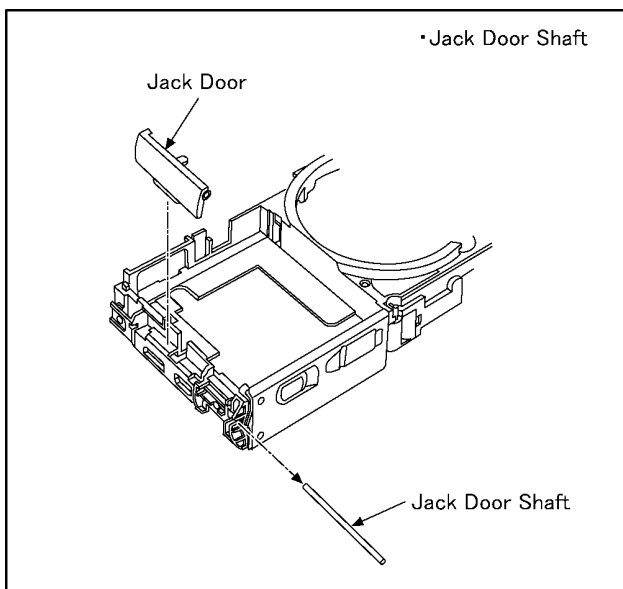

(Fig.D11)

8.3.10. Removal of the Battery Door Unit

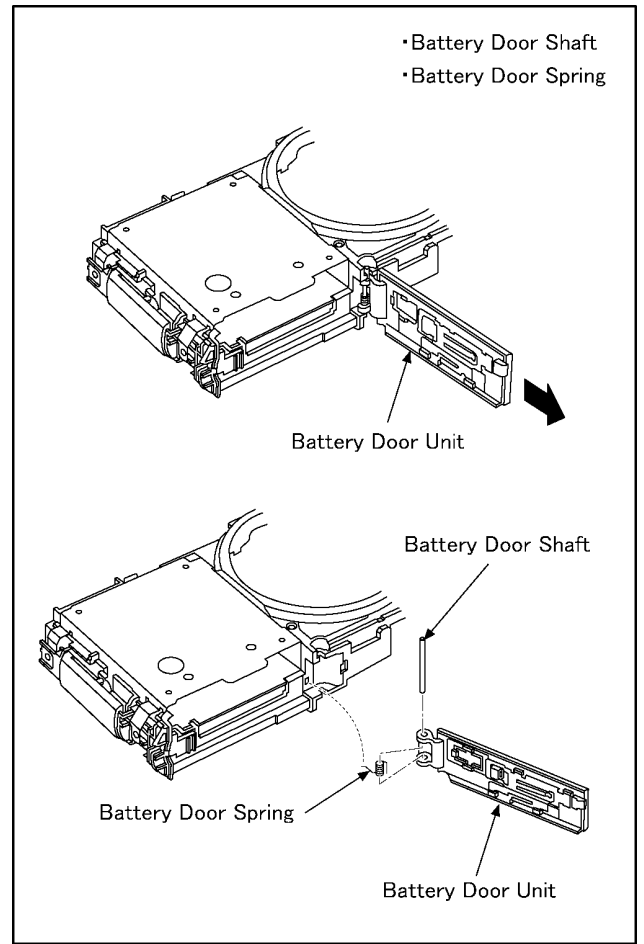

(Fig.D12)

NOTE: (When Assembling)

Be sure to confirm the following points when assembling.

- The Screw is tightened enough.
- Assembling conditions are fine. (No distortion, no illegal-space.)
- No dust and/or dirt on every Lens surfaces.
- LCD image is fine. (No dust and dirt on it, and no gradient images.)

8.4. Disassembly Procedure for the Lens

NOTE: When Disassembling and Assembling for the Lens

1. To minimize the possibility of the CCD being dirt, perform disassemble and/or assemble under the condition of the CCD is being mounted.

Disassembling procedures for the CCD unit, refer to item 8.6.

2. Take care that the dust and dirt are not entered into the lens.

In case of the dust is putted on the lens, blow off them by airbrush.

3. Do not touch the surface of lens.

4. Use lens cleaning KIT (BK)(VFK1900BK).

5. Apply the grease (RFKZ0472) to the point where is shown to "Grease apply" in the figure.

When the grease is applied, use a toothpick and apply thinly.

6. When repair the fixed frame, drive frame and direct frame, must be unit exchange.

8.4.1. Removal of the Zoom Motor Unit and Lens FPC P.C.B. Unit

1. Remove the 1 solder (A).
2. Remove the 1 solder (B).
3. Unscrew the 2 screws (A).
4. Unscrew the 1 screw (B).
5. Remove the 2 locks.
6. Remove the zoom motor unit to the indicated by arrow (1).
7. Remove the lens FPC P.C.B. unit to the indicated by arrow (2).

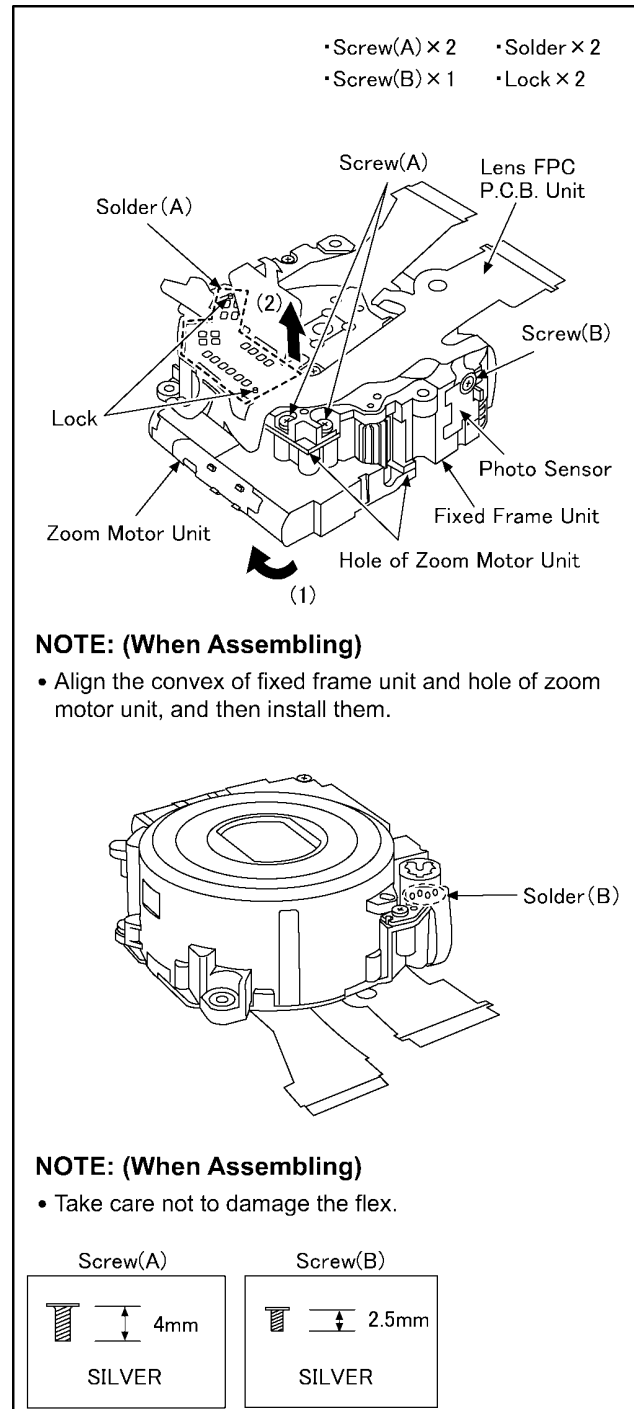

8.4.2. Removal of the Master Flange Unit

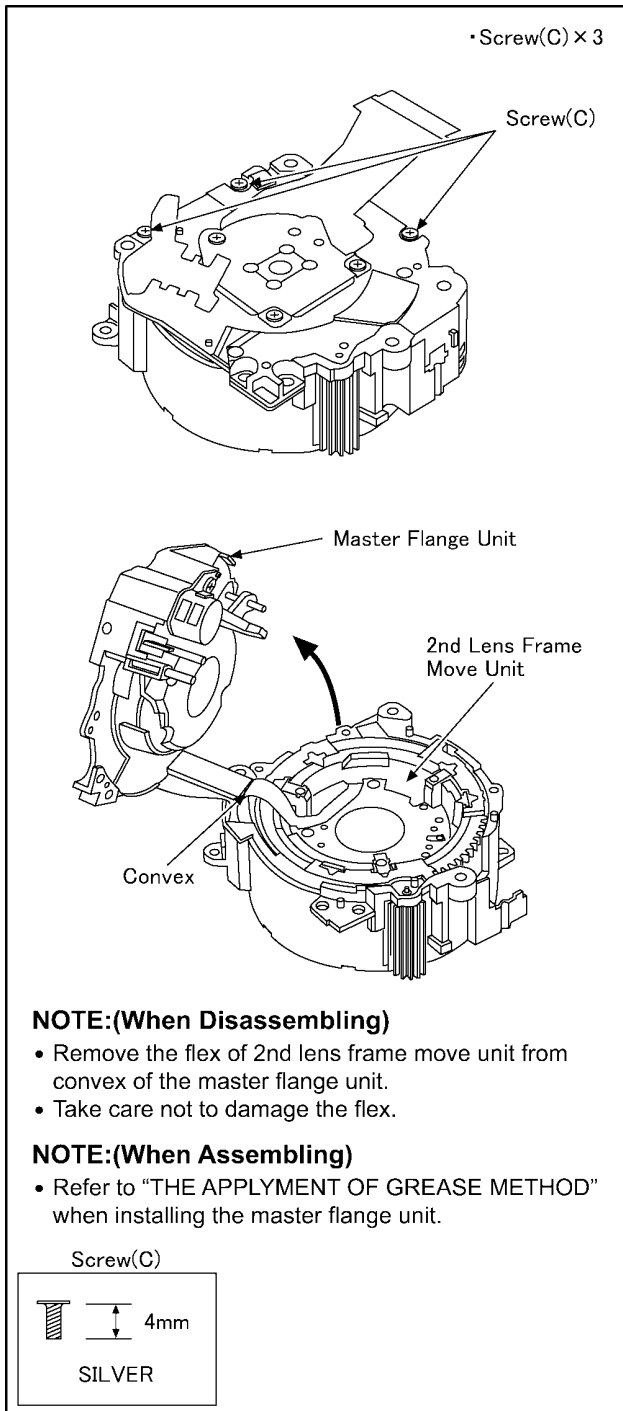

8.4.3. Removal of the 1st Lens Frame/2nd Lens Frame Move Unit

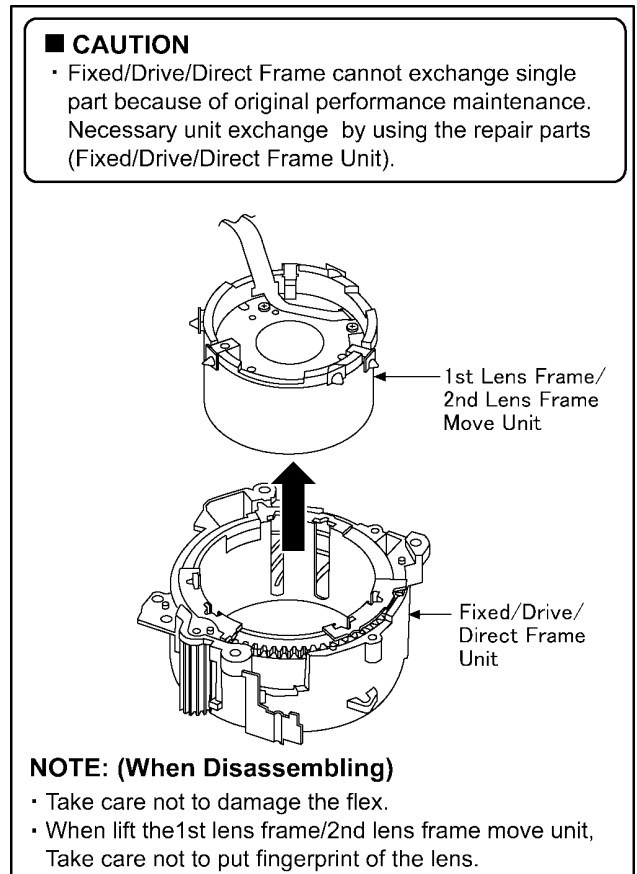

8.4.4. Removal of the 2nd Lens Frame Move Unit

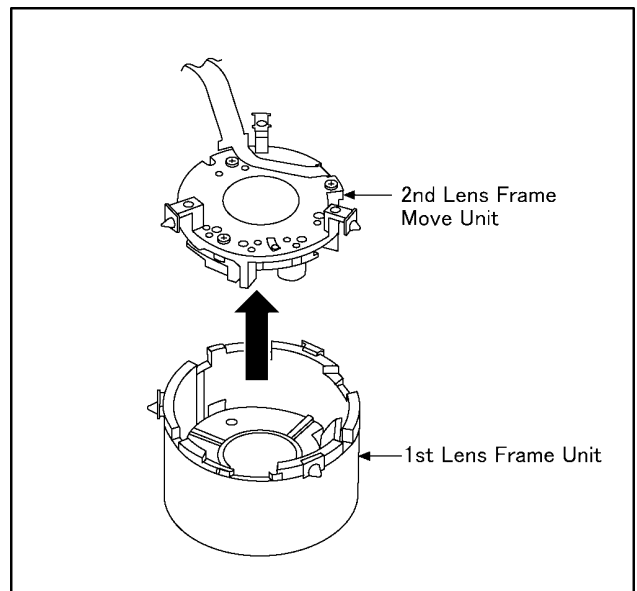

8.5. Assembly Procedure for the Lens

8.5.1. Phase alignment of the Direct Frame and Drive Frame Unit

- Insert the shading sheet to drive frame.
(When insert the shading sheet, so that the luster side facing to subject side.)
- Align the Δ mark of direct frame and groove in the interior of Δ mark of drive frame, and then install the direct frame to drive frame.

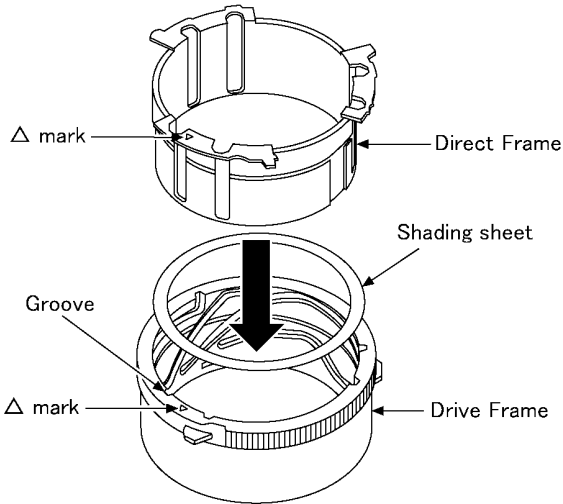

- Move the external U cut of direct frame to gear edge, and then align the phase of the groove (6 points).

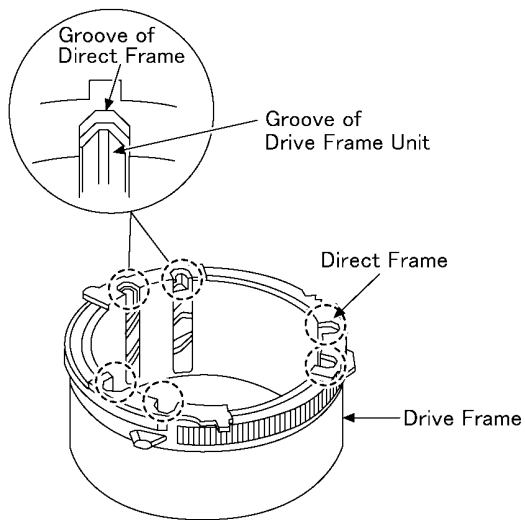

8.5.2. Phase alignment of the Drive/Direct Unit and Fixed Frame Unit

- Align the Δ mark, and then install the drive/direct frame unit to fixed frame unit.

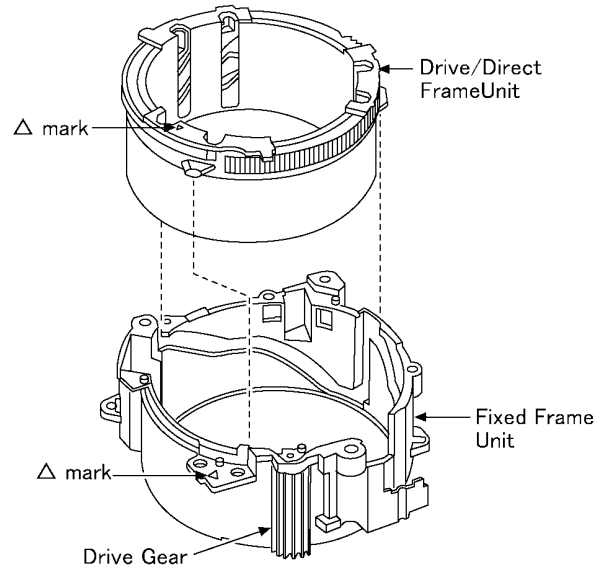

NOTE: (When Assembling)

- With aligning the phase of the drive/direct frame unit, confirm the gear of drive unit is engaged with the fixed frame unit firmly.

8.5.3. Assembly for the 1st Lens Frame Unit and Fixed/Drive/Direct Frame Unit

- Inserts the 1st lens frame unit to the fixed/drive/direct frame unit so that the barrier drive lever may become the position of the figure below.

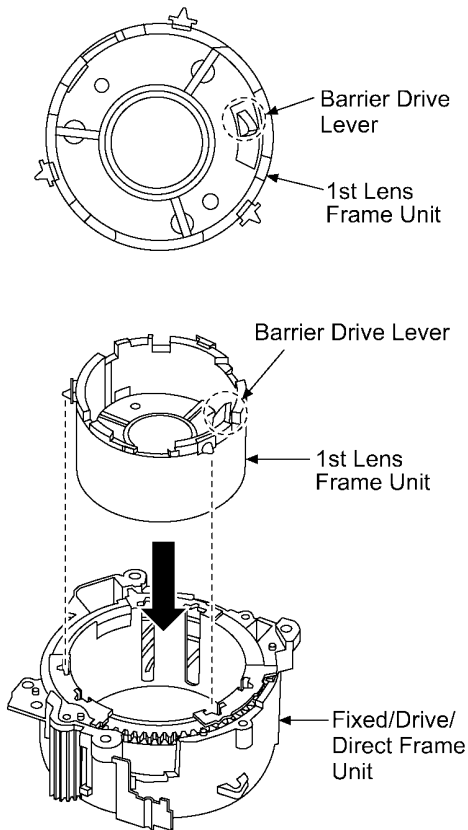

NOTE: (When Assembling)

Take care not to put fingerprint of the lens.

FRONT VIEW

- Install the 1st lens frame unit so that the "LEICA" character may become the position of the figure below.

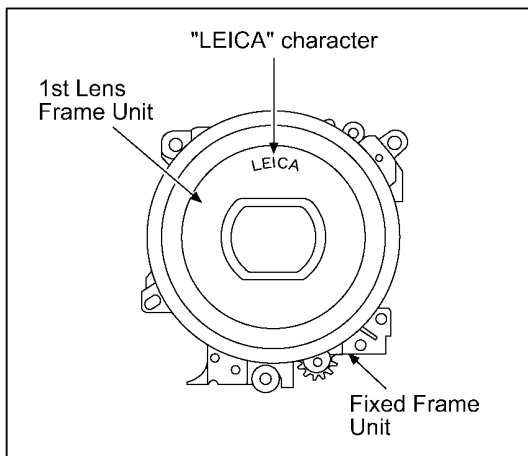

8.5.4. Assembly for the 2nd Lens Frame Move Unit and Fixed/Drive/Direct Frame/1st Lens Frame Unit

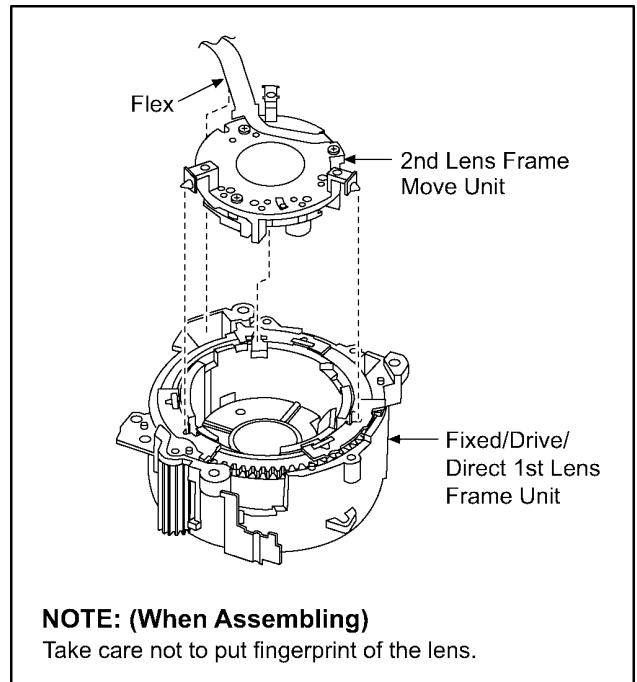

8.5.5. Assembly for the Master Flange Unit and Fixed/Drive/Direct Frame/1st Lens Frame/2nd Lens Frame Move Unit

•Screw(C) × 3

- Align the flex insert part of fixed frame unit and convex of the master flange unit, and then insert the master flange unit.

Flex
Flex insert part
Convex
Flex insert part
Master Flange Unit
Fixed/Drive/Direct 1st Lens Frame/2nd Lens Frame Move Unit

NOTE: (When Assembling)

- Take care not to damage the flex.
- Refer to "THE APPLYMENT OF GREASE METHOD" when installing the master flange unit.

Shutter
LE 2A

- Turn the Drive Gear in the direction of an arrow, and then confirm the lens shutter is closed.

Screw(C)
Drive Gear

Screw(C)
4mm
SILVER

8.6. Removal of the CCD Unit

•Screw(D) × 3 •Optical Filter × 1
• CCD Cushion × 1

CCD Unit
Screw(D)

Screw(D)
3mm
BLACK

CCD Cushion
Optical Filter
CCD side (red is pale)
Lens side (red is deep)

NOTE: (When Assembling)

Definitions of mount side of Optical filter.

- *Set the optical filter under the condition of reflecting the fluorescent lamp can be seen by your eyes.
- *Although depth of the red color may be changed in accordance with seeing angle, compare the deepest red color in both sides to define each side.
 - Lens side: red color is deeper than the other side.
 - CCD side: red color is paler than the other side.

It can be easy to confirm the red color density on the blue paper.

- *The optical filter might stuck to CCD unit.
- When replace the CCD unit, remove the optical filter, and then install it with CCD unit.

8.7. Removal of the Focus Motor Unit

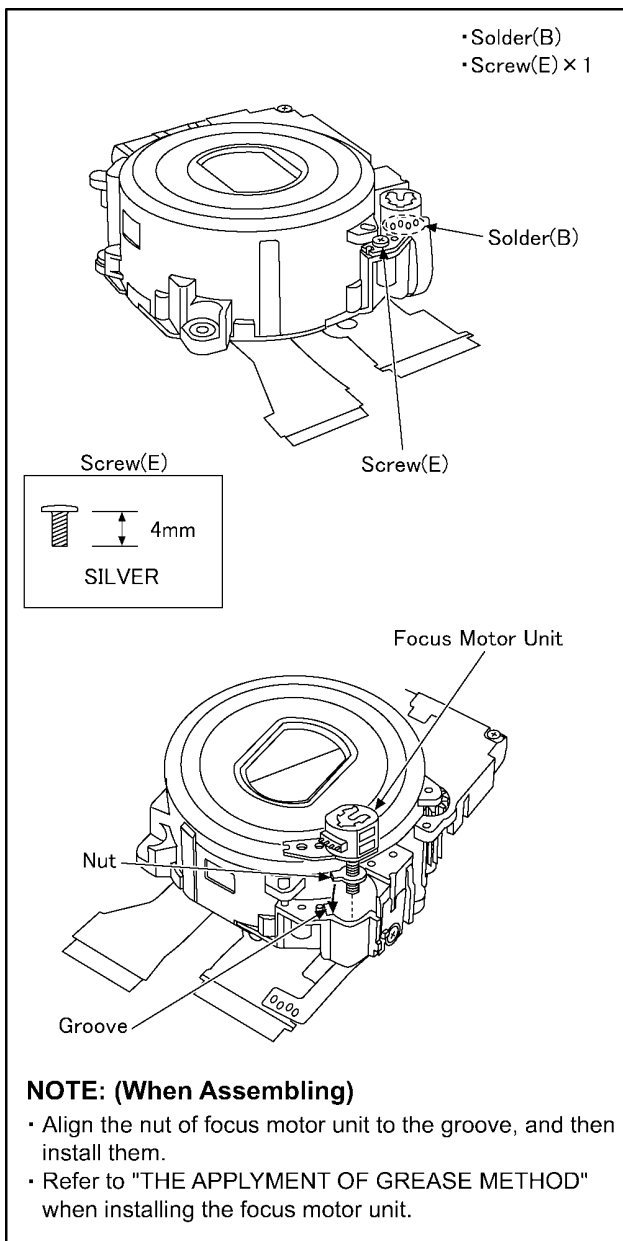

8.8. The Applyment of Grease Method

The grease apply point of lens unit are as follows.
Apply grease additionally in the specified position if necessary.
When the grease is applied, use a toothpick and apply thinly.

- Guide pole L,S/Fasten groove of nut/

Focus motor unit (lead screw)

- Grease: RFKZ0472

- Amount of apply: 2 - 4 mg

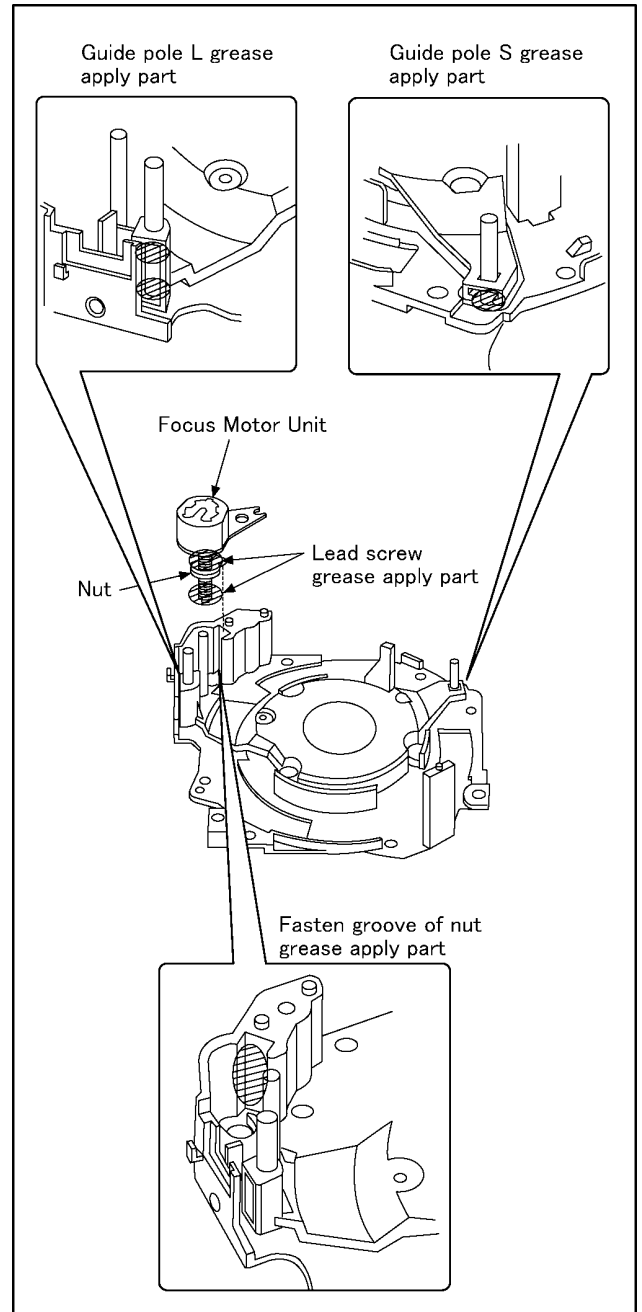

9 Measurements and Adjustments

9.1. Matrix Chart for Replaced Part and Necessary Adjustment

The relation between Replaced part and Necessary Adjustment is shown in the following table.

When concerned part is replaced, be sure to achieve the necessary adjustment(s).

As for Adjustment condition/procedure, consult the "Adjustment Manual" which is available in Adjustment software.

The Adjustment software is available at "TSN Website", therefore, access to "TSN Website" at "Support Information from NWBG/VDBG-AVC".

NOTE:

After adjustments have been terminated, make sure to achieve "INITIAL SETTINGS".

Adjustment Item		Replaced Part				
		Main P.C.B.	VENUS (IC6001)	Flash-ROM (IC6002)	Lens Part (Excluding CCD)	CCD Unit
Camera Section	OIS hall element adjustment (OIS)	○	○	○	○	—
	Back focus adjustment (BF)	○	○	○	○	○ ^{*1}
	Shutter adjustment (SHT)	○	○	○	○	○
	ISO sensitivity adjustment (ISO)	○	○	○	○	○
	AWB adjustment High brightness coloration inspection (WBL)	○	○	○	○	○
	CCD white scratch compensation (WKI)	○	○	○	—	○ ^{*1}
	CCD black scratch compensation (BKI)	○	○	○	—	○ ^{*1}
	Venus zoom inspection (PZM)	○	○	○	—	—
	Monitor linearity inspection (MLN)	○	○	○	○	○
	Colour reproduction inspection, MIC inspection (COL)	○	○	○	○	○

*1: This adjustment is necessary, not only replacing CCD unit but also removing it from the lens unit.

NOTE:

*There is no LCD adjustment in this model.

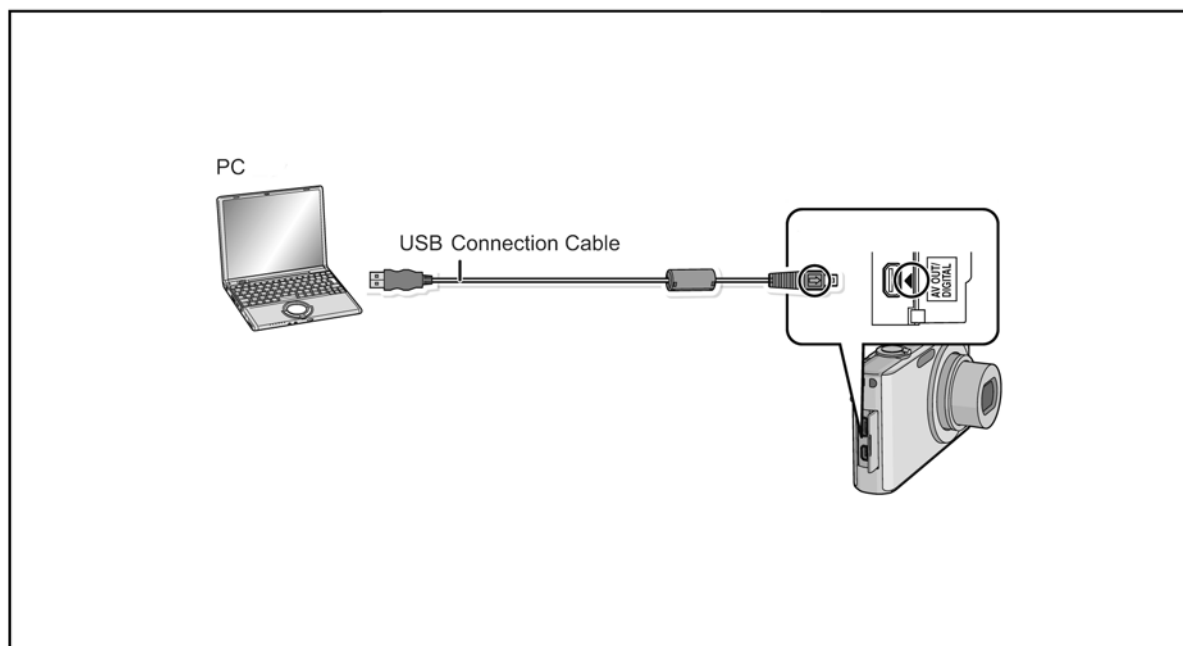

10 Maintenance

10.1. Cleaning Lens and LCD Panel

Do not touch the surface of lens and LCD Panel with your hand.

When cleaning the lens, use air-Blower to blow off the dust.

When cleaning the LCD Panel, dampen the lens cleaning paper with lens cleaner, and the gently wipe the their surface.

Note:

The Lens Cleaning KIT ; VFK1900BK (Only supplied as 10 set/Box) is available as Service Aid.

Service Manual

Diagrams and Replacement Parts List

Digital Camera

Model No.

DMC-FX40EB	DMC-FX48P	DMC-FX48GJ
DMC-FX40EE	DMC-FX48PC	DMC-FX48GK
DMC-FX40EF	DMC-FX48PU	DMC-FX48GT
DMC-FX40EG	DMC-FX48GC	
DMC-FX40EP	DMC-FX48GD	
DMC-FX40SG	DMC-FX48GH	

Vol. 1
Colour

- (S).....Silver Type (except PC/EF/GD)
- (K).....Black Type
- (P).....Pink Type (except P/PC/PU/EB/EF/EP)
- (R).....Red Type (only PC/EB/EE/EF/EG/EP/SG)
- (W).....White Type (only EF/EG/GH)
- (N).....Gold Type (only EE/EP/GC/GK/SG)

Table of contents

S1. About Indication of The Schematic Diagram.....	S-1	S6. Replacement Parts List.....	S-11
S1.1. Important Safety Notice.....	S-1		
S2. Voltage Chart	S-2	S7. Exploded View	S-16
S2.1. Flash Top P.C.B.....	S-2	S7.1. Frame and Casing Section.....	S-16
		S7.2. Packing Parts and Accessories Section (1)	S-17
S3. Block Diagram.....	S-3	S7.3. Packing Parts and Accessories Section (2)	S-18
S3.1. Overall Block Diagram	S-3		
S4. Schematic Diagram.....	S-4		
S4.1. Interconnection Diagram	S-4		
S4.2. Flash Top Schematic Diagram	S-5		
S4.3. CCD Flex Schematic Diagram	S-6		
S4.4. Lens Flex Schematic Diagram	S-7		
S5. Print Circuit Board.....	S-8		
S5.1. Flash Top P.C.B.....	S-8		
S5.2. CCD Flex P.C.B.....	S-9		
S5.3. Lens Flex P.C.B.....	S-10		

S1. About Indication of The Schematic Diagram

S1.1. Important Safety Notice

COMPONENTS IDENTIFIED WITH THE MARK \triangle HAVE THE SPECIAL CHARACTERISTICS FOR SAFETY. WHEN REPLACING ANY OF THESE COMPONENTS USE ONLY THE SAME TYPE.

1. Although reference number of the parts is indicated on the P.C.B. drawing and/or schematic diagrams, it is NOT mounted on the P.C.B. when it is displayed with "\$" mark.
2. It is only the "Test Round" and no terminal (Pin) is available on the P.C.B. when the TP (Test Point) indicated as "●" mark.
3. The voltage being indicated on the schematic diagram is measured in "Standard-Playback" mode when there is no specify mode is mentioned.
4. Although the voltage and waveform available on here is measured with standard frame, it may be differ from actual measurement due to modification of circuit and so on.
5. The voltage being indicated here may be include observational-error (deviation) due to internal-resistance and/or reactance of equipment. Therefore, handle the value indicated on here as reference.
6. Use the parts number indicated on the Replacement Parts List .
7. Indication on Schematic diagrams:

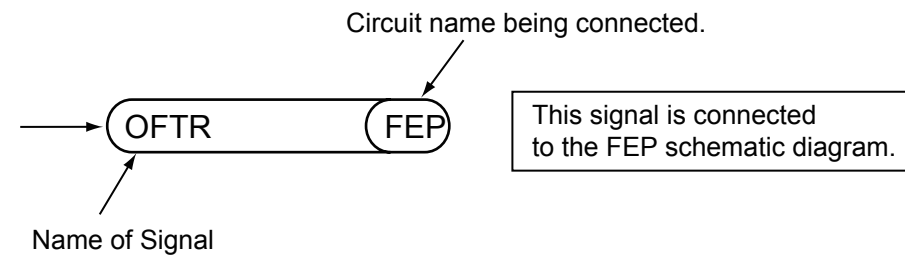

S2. Voltage Chart

Note) Indicated voltage values are the standard values for the unit measured by the DC electronic circuit tester (high-impedance) with the chassis taken as standard.
Therefore, there may exist some errors in the voltage values, depending on the internal impedance of the DC circuit tester.

S2.1. Flash Top P.C.B.

REF No.	PIN No.	POWER ON
IC8001	2	0
IC8001	3	0
IC8001	4	0
IC8001	5	6
Q8009	1	6.9
Q8009	2	6.9
Q8009	3	0
Q8009	4	0
Q8009	5	6.9
Q8009	6	6.9

S3. Block Diagram

S3.1. Overall Block Diagram

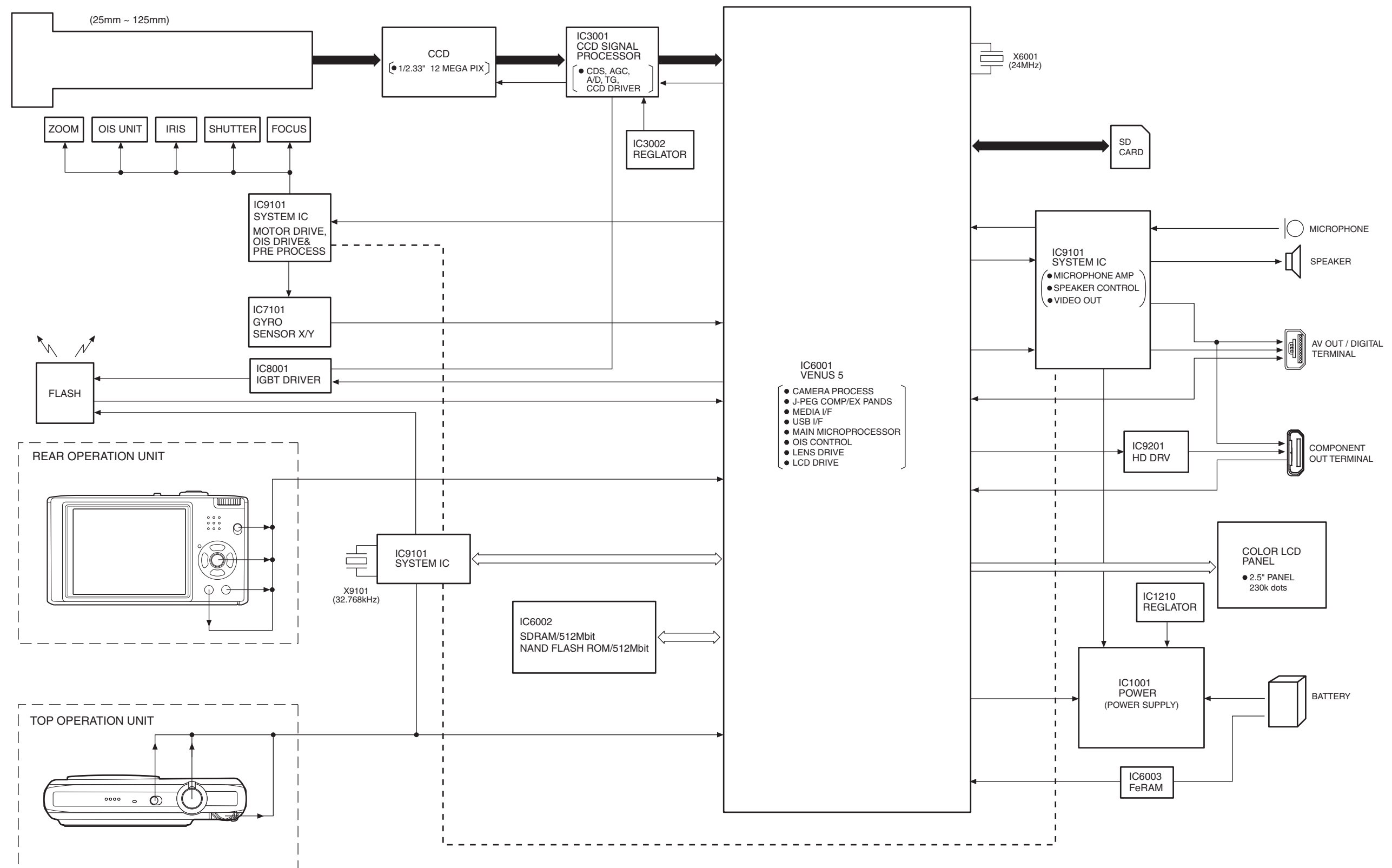

S4. Schematic Diagram

S4.1. Interconnection Diagram

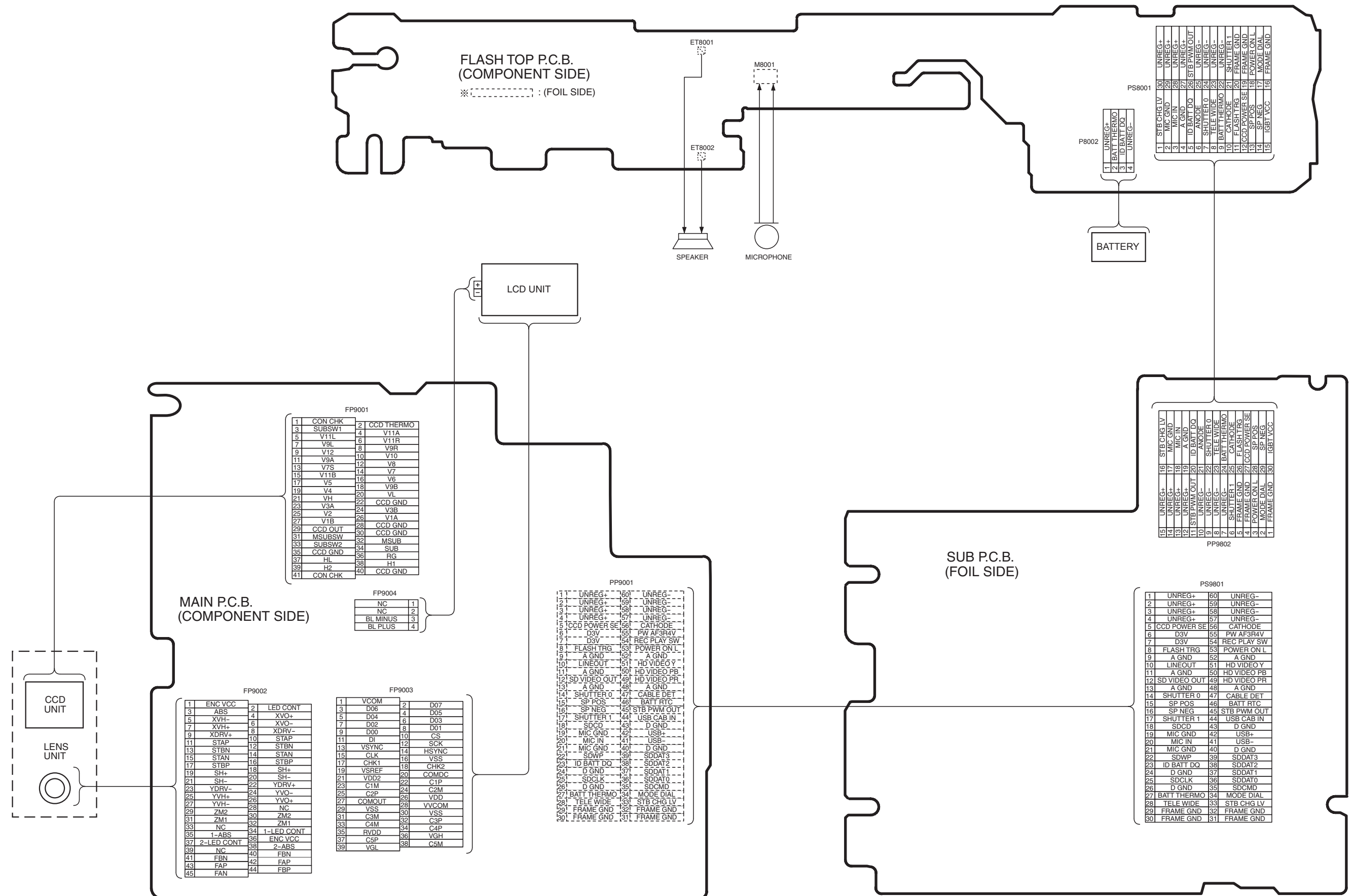

S4.2. Flash Top Schematic Diagram

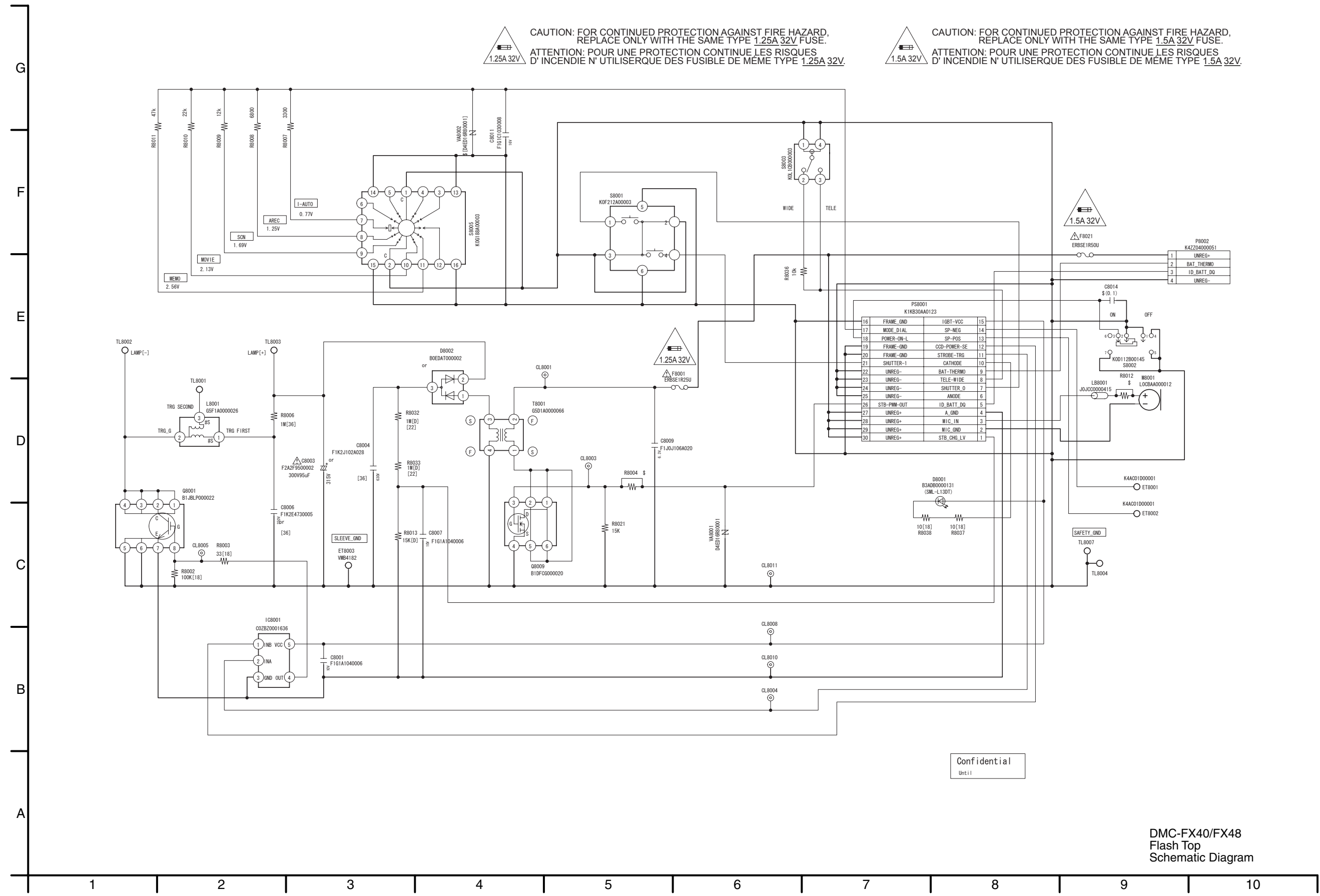

Confidential
 Unt 11

S4.3. CCD Flex Schematic Diagram

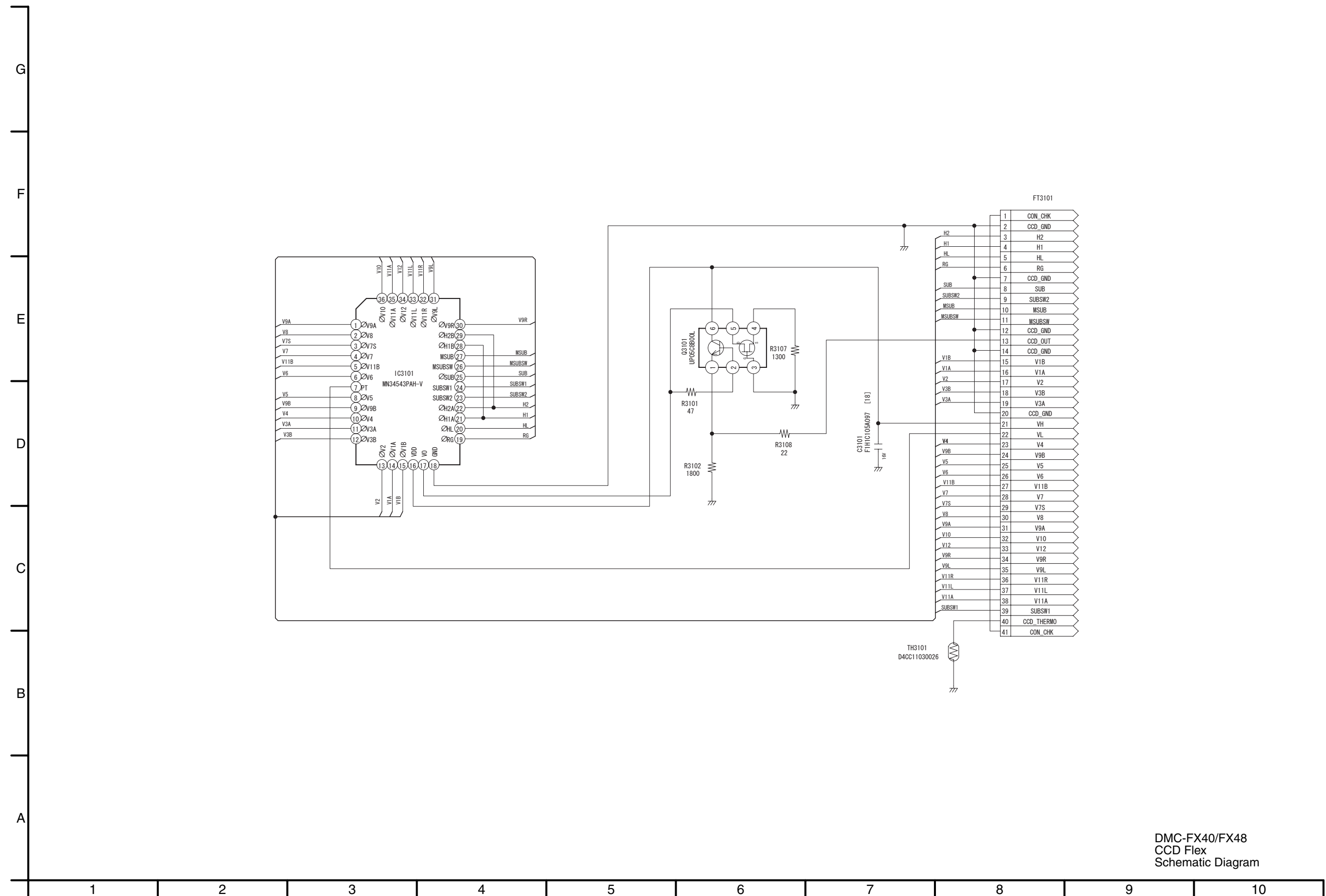

DMC-FX40/FX48
CCD Flex
Schematic Diagram

S4.4. Lens Flex Schematic Diagram

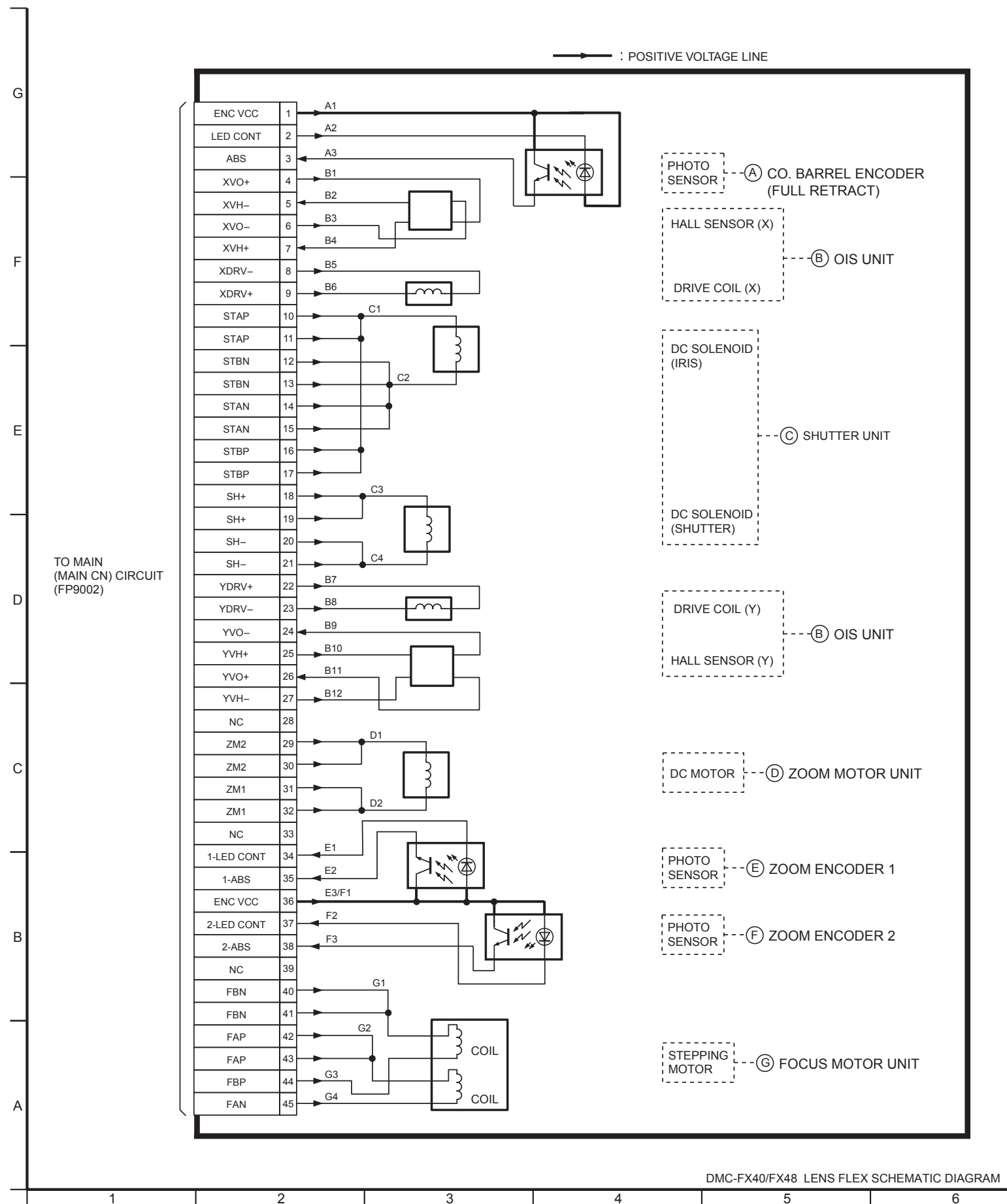

S5. Print Circuit Board

S5.1. Flash Top P.C.B.

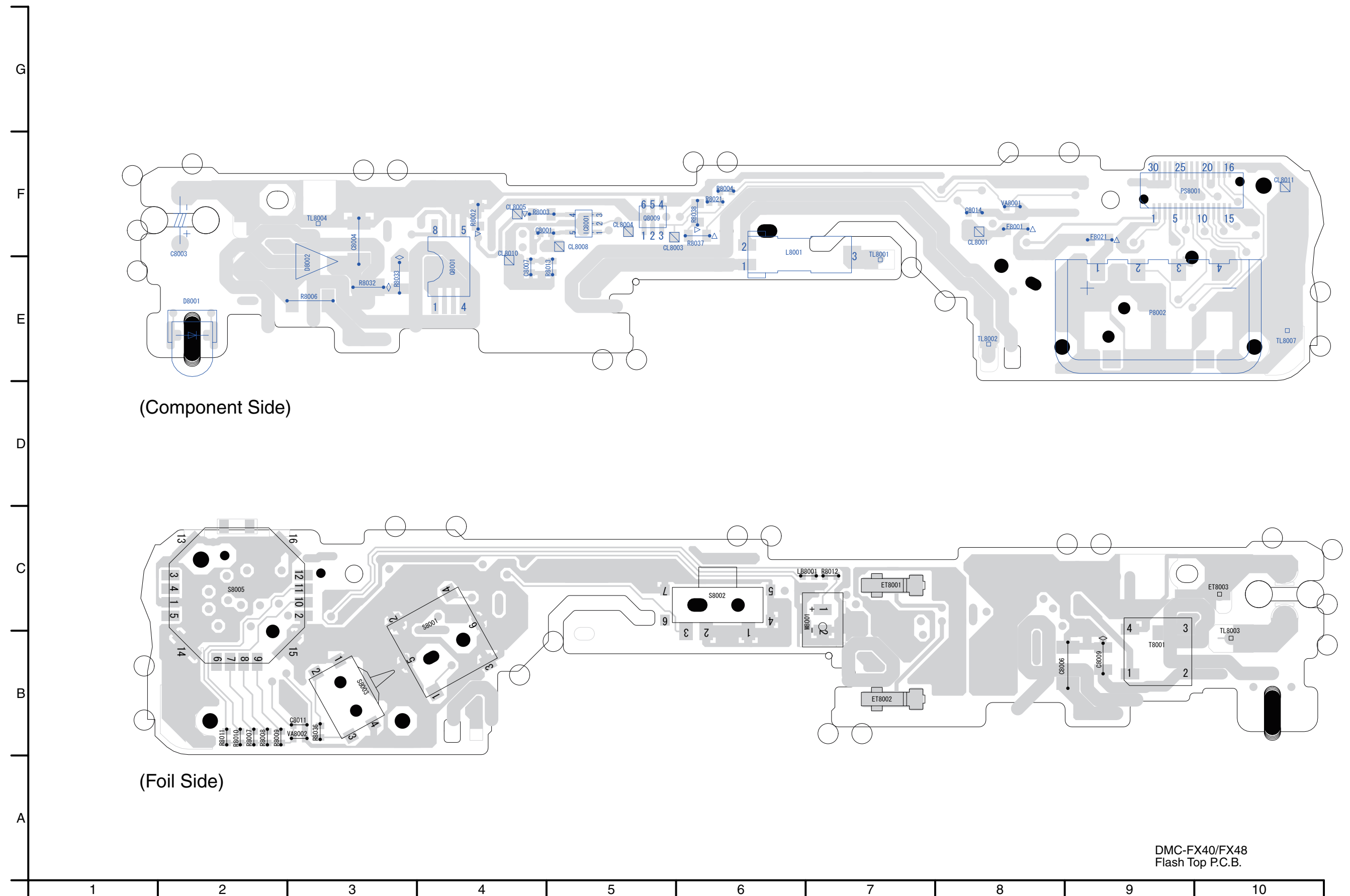

S5.2. CCD Flex P.C.B.

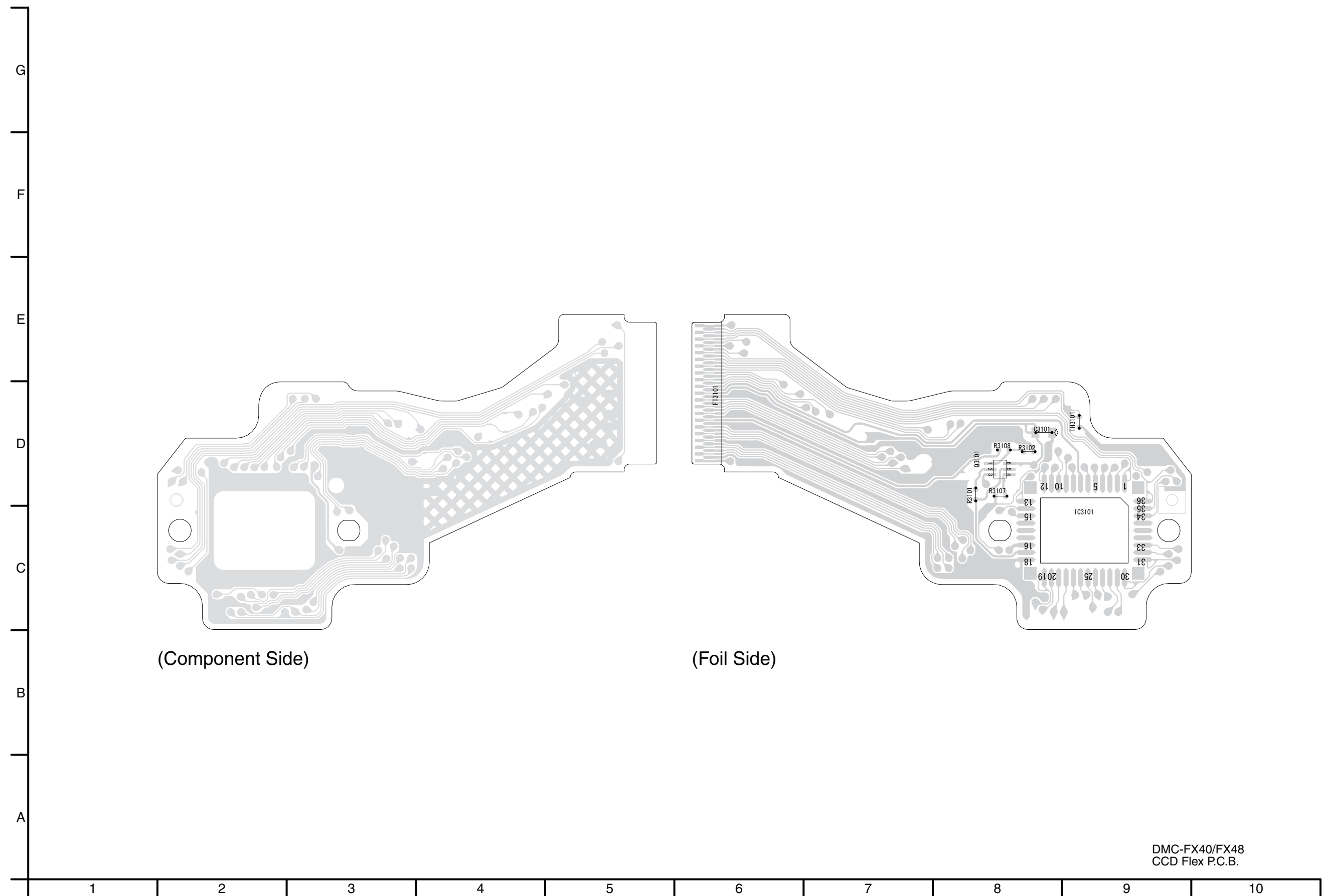

DMC-FX40/FX48
CCD Flex P.C.B.

S5.3. Lens Flex P.C.B.

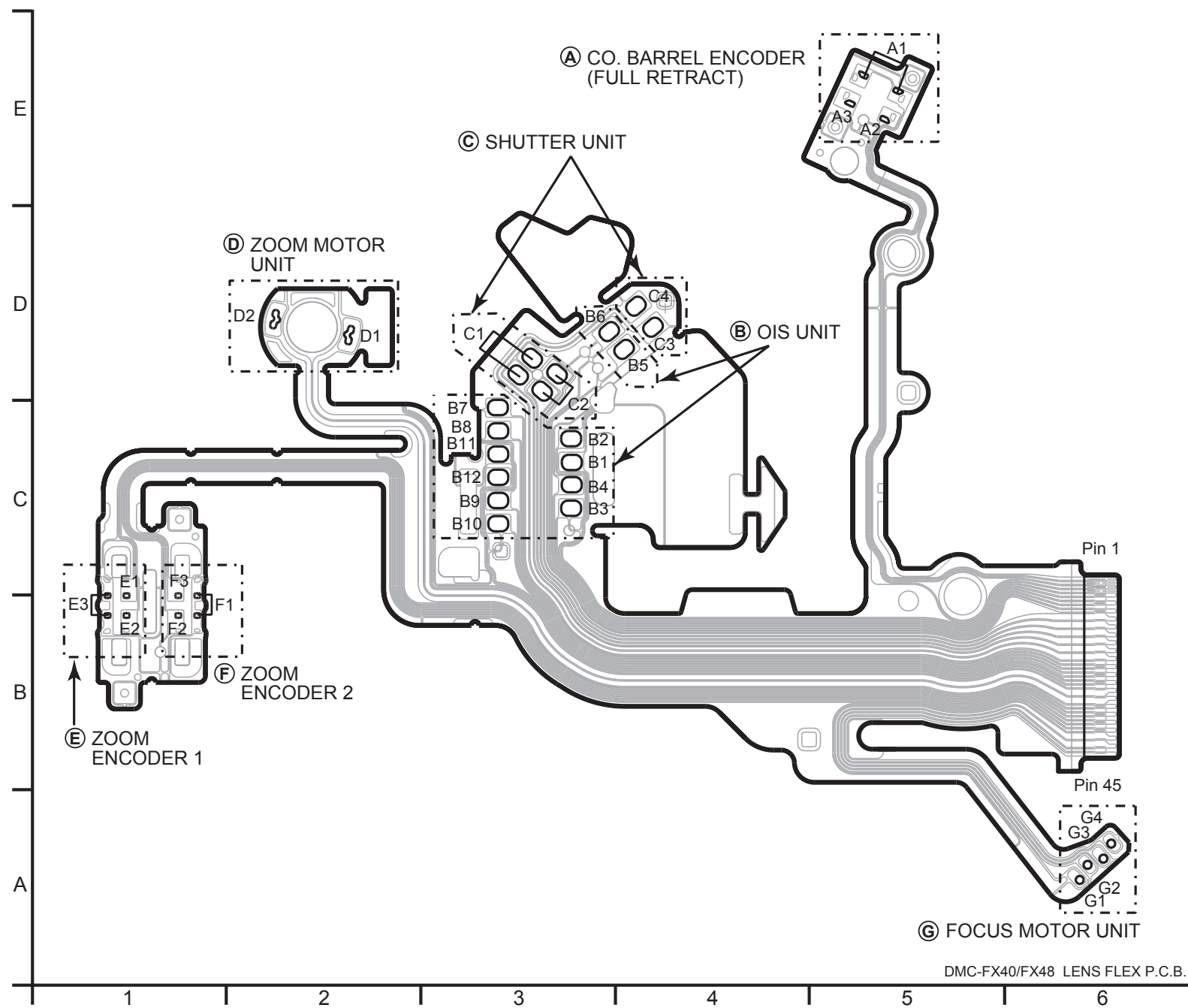

S6. Replacement Parts List

- Note:
1. * Be sure to make your orders of replacement parts according to this list.
 2. **IMPORTANT SAFETY NOTICE**
Components identified with the mark  have the special characteristics for safety.
When replacing any of these components, use only the same type.
 3. Unless otherwise specified,
All resistors are in OHMS, K=1,000 OHMS. All capacitors are in MICRO-FARADS (uf), P=uuF.
 4. The marking (RTL) indicates the retention time is limited for this item. After the discontinuation of this assembly in production, it will no longer be available.
 5. Supply of CD-ROM, in accordance with license protection, is allowable as replacement parts only for customers who accidentally damaged or lost their own.

E.S.D. standards for Electrostatically Sensitive Devices, refer to PREVENTION OF ELECTROSTATIC DISCHARGE (ESD) TO ELECTROSTATICALLY SENSITIVE (ES) DEVICES section.

Definition of Parts supplier:

1. **Parts marked with [ENERGY] in the remarks column are supplied from Panasonic Corporation Energy Company.**

DMC-FX40EB/EE/EF/EG/EP/SG/FX48P/PC/PU/GC/GD/GH/GJ/GK/GT
VEP58078A / VEK0N50

Ref.No.	Part No.	Part Name & Description	Pcs	Remarks	Ref.No.	Part No.	Part Name & Description	Pcs	Remarks
		----- P.C.B. LIST -----							
	VEP56079A	MAIN P.C.B.		(RTL) E.S.D.	R3101	ERJ2GEJ470	M.RESISTOR CH 1/16W 47	1	
	VEP56080A	SUB P.C.B.		(RTL) E.S.D.	R3102	ERJ2GEJ182	M.RESISTOR CH 1/16W 1.8K	1	
	VEP58078A	FLASH TOP P.C.B.		(RTL) E.S.D.	R3107	ERJ2GEJ132	M.RESISTOR CH 1/16W 1.3K	1	
	VEK0N50	CCD UNIT		E.S.D.	R3108	ERJ2GEJ220	M.RESISTOR CH 1/16W 22	1	
		--- INDIVIDUAL PARTS ---			TH3101	D4CC11030026	NTC THERMISTORS	1	
A C8003	F2A2F9500002	E.CAPACITOR							
ET8003	VMB4182	EARTH SPRING							
		--- ELEC. COMPONENTS ---							
##	VEP58078A	FLASH TOP P.C.B.		(RTL) E.S.D.					
C8001	F1G1A104A012	C.CAPACITOR CH 10V 0.1U	1						
C8004	F1K2J102A028	C.CAPACITOR 630V 1000P	1						
C8006	F1K2E4730005	C.CAPACITOR 250V 0.047U	1						
C8007	F1G1A104A012	C.CAPACITOR CH 10V 0.1U	1						
C8009	F1J0J106A020	C.CAPACITOR CH 6.3V 10U	1						
C8011	F1G1C1030008	C.CAPACITOR CH 16V 0.01U	1						
D8001	B3ADB0000131	DIODE	1	E.S.D.					
D8002	B0EDAT000002	DIODE	1	E.S.D.					
ET8001	K4AC01D00001	EARTH SPRING	1						
ET8002	K4AC01D00001	EARTH SPRING	1						
A F8001	ERBSE1R25U	FUSE 32V 1.25A	1						
A F8021	ERBSE1R50U	FUSE 32V 1.5A	1						
IC8001	C0ZBZ0001636	IC	1	E.S.D.					
L8001	G5F1A0000026	INDUCTOR	1						
LB8001	J0JCC0000415	FILTER	1						
M8001	L0CBAA000012	MICROPHONE UNITS	1						
P8002	K4ZZ04000051	CONNECTOR 4P	1						
PS8001	K1KB30AA0123	CONNECTOR 30P	1						
Q8001	B1JBLP000022	TRANSISTOR	1	E.S.D.					
Q8009	B1DFCG000020	TRANSISTOR	1	E.S.D.					
R8002	ERJ3GEYJ104	M.RESISTOR CH 1/10W 100K	1						
R8003	ERJ3GEYJ330	M.RESISTOR CH 1/10W 33	1						
R8006	ERJ8GEYJ105V	M.RESISTOR CH 1/8W 1M	1						
R8007	ERJ2GEJ332	M.RESISTOR CH 1/16W 3.3K	1						
R8008	ERJ2RHD682X	M.RESISTOR CH 1/16W 6.8K	1						
R8009	ERJ2GEJ123	M.RESISTOR CH 1/16W 12K	1						
R8010	ERJ2GEJ223	M.RESISTOR CH 1/16W 22K	1						
R8011	ERJ2GEJ473	M.RESISTOR CH 1/16W 47K	1						
R8013	ERJ2RHD153X	M.RESISTOR CH 1/16W 15K	1						
R8021	ERJ2GEJ153	M.RESISTOR CH 1/16W 15K	1						
R8032	ERJ6RED105	M.RESISTOR CH 1/16W 1M	1						
R8033	ERJ6RED105	M.RESISTOR CH 1/16W 1M	1						
R8036	ERJ2GEJ103	M.RESISTOR CH 1/16W 10K	1						
R8037	ERJ3GEYJ100	M.RESISTOR CH 1/10W 10	1						
R8038	ERJ3GEYJ100	M.RESISTOR CH 1/10W 10	1						
S8001	K0F212A00003	SWITCH	1						
S8002	K0D112B00145	SWITCH	1						
S8003	K0L1CB000003	SWITCH	1						
S8005	K0G188A00003	SWITCH	1						
T8001	G5D1A0000066	TRANSFORMER	1						
VA8001	D4ED16R80001	VARISTOR	1						
##	VEK0N50	CCD UNIT		E.S.D.					
C3101	F1H1C105A097	C.CAPACITOR CH 16V 1U	1						
Q3101	UP05C8B00L	TRANSISTOR	1	E.S.D.					

DMC-FX40EB/EE/EF/EG/EP/SG/FX48P/PC/PU/GC/GD/GH/GJ/GK/GT

Ref.No.	Part No.	Part Name & Description	Pcs	Remarks	Ref.No.	Part No.	Part Name & Description	Pcs	Remarks
1	VEP56079A	MAIN P.C.B.	1	(RTL) E.S.D.	100	VXW1018	LENS UNIT(W/O CCD)	1	
2	VEP56080A	SUB P.C.B.	1	(RTL) E.S.D.	101	VDL2316	OPTICAL FILTER	1	
3	VGQ0B96	PCB SPACER	1		102	VEK0N50	CCD UNIT	1	E.S.D.
4	VGU0D79	SLIDE KNOB	1		103	VMX3650	CCD CUSHION	1	
A	ML-421S/ZTK	BUTTON BATTERY	1	(B9801)[ENERGY]	104	VXP3021	1ST LENS FRAME UNIT	1	
7	VGQ8836	BATTERY LOCK KNOB	1		105	VXP3208	FIX/DRIVE/DIRECT FRAME UNIT	1	
8	VKF4436	JACK DOOR	1	(S,R,W,N,P)	109	L6DA8BEC0003	ZOOM MOTOR	1	
8	VKF4438	JACK DOOR	1	(K)	110	VXP3237	2ND LENS FRAME UNIT	1	
9	VMB3962	BATTERY LOCK SPRING	1		113	VXQ1756	MASTER FLANGE UNIT	1	
10	VMB4094	BATTERY OUT SPRING	1		113-1	L6HA64NC0014	FOCUS MOTOR UNIT	1	
11	VMB4150	BATTERY DOOR SPRING	1		113-2	VMB4158	FOCUS SPRING	1	
12	VMP9253	FRAME	1		113-3	VXP3234	3RD LENS FRAME UNIT	1	
13	VMP9256	BATTERY CASE	1		114	VEK0N51	LENS FPC UNIT	1	
14	VMS7867	BATTERY DOOR SHAFT	1		114-1	B3NBA0000011	PHOTO SENSOR	1	
15	VMS7983	JACK DOOR SHAFT	1		114-2	B3NBA0000011	PHOTO SENSOR	1	
16	VYF3247	BATTERY DOOR UNIT	1	(S,R,W,N,P)	114-3	B3NBA0000011	PHOTO SENSOR	1	
16	VYF3248	BATTERY DOOR UNIT	1	(K)					
17	VGL1268	AF PANEL LIGHT	1		B100	VHD1871	SCREW	1	
18	VYK2Z68	TOP ORNAMENT UNIT	1	FX40-S,R,W,N,P	B101	VHD1871	SCREW	1	
18	VYK2Z70	TOP ORNAMENT UNIT	1	FX40-K	B102	VHD1871	SCREW	1	
18	VYK2Z69	TOP ORNAMENT UNIT	1	FX48-S,R,W,N,P	B103	XQN14+CJ4FN	SCREW	1	
18	VYK2Z71	TOP ORNAMENT UNIT	1	FX48-K	B104	XQN14+CJ4FN	SCREW	1	
19	EFN-FSAJ8ZC	FLASH UNIT	1		B105	XQN14+CJ4FN	SCREW	1	
20	VEP58078A	FLASH TOP P.C.B.	1	(RTL) E.S.D.	B106	XQN14+CJ4FN	SCREW	1	
21	VYQ4113	MIC DAMPER	1		B107	VHD2011	SCREW	1	
A	F2A2F9500002	E.CAPACITOR	1	(C8003)	B108	XQN14+CJ4FN	SCREW	1	
23	VMB4182	EARTH SPRING	1	(ET8003)	B109	XQN14+CJ4FN	SCREW	1	
24	VYQ4558	MODE DIAL UNIT	1	(S,R,W,N,P)					
24	VYQ4559	MODE DIAL UNIT	1	(K)					
25	VMP9247	SIDE ORNAMENT L	1	(S,R,W,N,P)					
25	VMP9249	SIDE ORNAMENT L	1	(K)					
26	VMP9248	SIDE ORNAMENT R	1	(S,R,W,N,P)					
26	VMP9250	SIDE ORNAMENT R	1	(K)					
27	VMP9254	REAR PLATE	1						
28	VMP9299	TORIPD	1						
29	VYK2Z43	FRONT CASE UNIT	1	(S)					
29	VYK2Z45	FRONT CASE UNIT	1	(R)					
29	VYK2Z48	FRONT CASE UNIT	1	(W)					
29	VYK2Z44	FRONT CASE UNIT	1	(K)					
29	VYK2Z47	FRONT CASE UNIT	1	(N)					
29	VYK2Z46	FRONT CASE UNIT	1	(P)					
30	VYK2Z55	REAR CASE UNIT	1	(S)					
30	VYK2Z57	REAR CASE UNIT	1	(R)					
30	VYK2Z60	REAR CASE UNIT	1	(W)					
30	VYK2Z56	REAR CASE UNIT	1	(K)					
30	VYK2Z59	REAR CASE UNIT	1	(N)					
30	VYK2Z58	REAR CASE UNIT	1	(P)					
30-1	VGL1292	REAR PANEL LIGHT	1						
30-2	VGU0D78	CURSOR BUTTON	1						
31	VYK2Z61	LCD UNIT	1						
32	VYK3F46	LCD PANEL UNIT	1						
B1	VHD1694	SCREW	1						
B2	VHD1876	SCREW	1						
B3	VHD1876	SCREW	1						
B4	VHD2018	SCREW	1	(S,R,W,N,P)					
B4	VHD2041	SCREW	1	(K)					
B5	VHD2036	SCREW	1	(S,R,W,N,P)					
B5	VHD2022	SCREW	1	(K)					
B6	VHD2036	SCREW	1	(S,R,W,N,P)					
B6	VHD2022	SCREW	1	(K)					
B7	VHD2036	SCREW	1	(S,R,W,N,P)					
B7	VHD2022	SCREW	1	(K)					
B8	VHD2036	SCREW	1	(S,R,W,N,P)					
B8	VHD2022	SCREW	1	(K)					
B9	XQN16+B5FN	SCREW	1						
B10	XQN16+B5FN	SCREW	1						
B11	XQN16+BJ7FJK	SCREW	1						
B12	XQN16+BJ7FJK	SCREW	1						
B13	XQN16+BJ7FJK	SCREW	1						

DMC-FX40EB/EE/EF/EG/EP/SG/FX48P/PC/PU/GC/GD/GH/GJ/GK/GT

Ref.No.	Part No.	Part Name & Description	Pcs	Remarks	Ref.No.	Part No.	Part Name & Description	Pcs	Remarks
300	VPF1317	CAMERA BAG	1	EXCEPT P,PC	315	VQT1W16	O/I SOFTWARE	1	EP
△ 302	DE-A59BA	BATTERY CHARGER	1	PU			(FINNISH/SWEDISH/DANISH/ POLISH/CZECH/HUNGARIAN)		
△ 302	DE-A60AA	BATTERY CHARGER	1	EB,EF,EG,EP	315	VQT1W20	O/I SOFTWARE	1	GC,GH,SG,GJ
△ 302	DE-A60BA	BATTERY CHARGER	1	EE,GC,GD,GH,GJ,GK			(ENGLISH/CHINESE(TRADITIONAL)/ ARABIC/PERSIAN)		
△ 302	DE-A60EA	BATTERY CHARGER	1	SG	315	VQT1W25	O/I SOFTWARE	1	GD
△ 302	DE-A60CA	BATTERY CHARGER	1	GT			(KOREAN)		
△ 303	----	BATTERY	1	EXCEPT P,PC	315	VQT1X99	O/I SOFTWARE	1	GK
304	K1HA08AD0003	USB CABLE W/PLUG	1	EXCEPT P,PC	315	VQT1X98	O/I SOFTWARE	1	GT
305	K1HA08CD0020	AV CABLE W/PLUG	1	EXCEPT P,PC			(CHINESE(SIMPLIFIED))		
306	VFC4297	HAND STRAP	1	EXCEPT P,PC	315	VQT1X98	O/I SOFTWARE	1	GT
307	VFF0445-S	CD-ROM	1	PU,EB,EE,EF,EG,EP,SG,GC, GD,GH,GJ,GT See"Notes"			(CHINESE(TRADITIONAL))		
307	VFF0446-S	CD-ROM	1	GK See"Notes"	316	VPN6666	PAD	1	EB,GC,GH
308	VGQ0D56	BATTERY PROTECTION CASE	1	EXCEPT P,PC	316	VPN6664	PAD	1	EE,EF,EG,EP,SG,PU,GD,GJ,GK,GT
309	VPK3759	PACKING CASE	1	FX40-S	318	VQL1G34-6	OPERATING LABEL	1	GT
309	VPK3776	PACKING CASE	1	FX40-R	△ 319	K2CT3CA00004	AC CORD W/PLUG	1	EB,GC,GH
309	VPK3772	PACKING CASE	1	FX40-W	△ 320	K2CQ2CA00006	AC CORD W/PLUG	1	EE,EF,EG,EP,GC
309	VPK3764	PACKING CASE	1	FX40-K	△ 320	K2CR2CA00003	AC CORD W/PLUG	1	GD
309	VPK3778	PACKING CASE	1	FX40-N	△ 320	K2CP2YY00001	AC CORD W/PLUG	1	GJ
309	VPK3768	PACKING CASE	1	FX40-P	△ 322	K2CA2CA00019	AC CORD W/PLUG	1	SG
309	VPK3760	PACKING CASE	1	PUS,GCS,GHS,GJS,GTS	△ 322	K2CA2CA00020	AC CORD W/PLUG	1	GK
309	VPK3765	PACKING CASE	1	PUK,GCK,GDK,GHK,GJK,GTK	△ 322	K2CA2CA00027	AC CORD W/PLUG	1	GT
309	VPK3779	PACKING CASE	1	GCN					
309	VPK3769	PACKING CASE	1	GCP,GDP,GHP,GJP,GTP					
309	VPK3773	PACKING CASE	1	GHW					
309	VPK3761	PACKING CASE	1	GKS					
309	VPK3766	PACKING CASE	1	GKK					
309	VPK3780	PACKING CASE	1	GKN					
309	VPK3770	PACKING CASE	1	GKP					
310	VPN6657	CUSHION	1	EXCEPT P,PC					
312	VPF1294	BAG, POLYETHYLENE	1	EXCEPT P,PC					
△ 313	VFF0474-J	CD-ROM(INSTRUCTION BOOK)	1	PU					
△ 313	VFF0460-J	CD-ROM(INSTRUCTION BOOK)	1	EG,EP,SG					
△ 313	VFF0461-J	CD-ROM(INSTRUCTION BOOK)	1	GC,GH,GJ					
△ 314	VQT1X60	SIMPLIFIED O/I (SPANISH/PORTUGUESE)	1	PU					
△ 314	VQT1X69	INSTRUCTION BOOK (ENGLISH)	1	EB					
△ 314	VQT1X70	INSTRUCTION BOOK (RUSSIAN)	1	EE					
△ 314	VQT1X71	INSTRUCTION BOOK (UKRAINIAN)	1	EE					
△ 314	VQT1X68	INSTRUCTION BOOK (FRENCH)	1	EF					
△ 314	VQT1X62	SIMPLIFIED O/I (GERMAN/FRENCH)	1	EG					
△ 314	VQT1X63	SIMPLIFIED O/I (ITALIAN/DUTCH)	1	EG					
△ 314	VQT1X64	SIMPLIFIED O/I (SPANISH/PORTUGUESE)	1	EG					
△ 314	VQT1X65	SIMPLIFIED O/I (SWEDISH/DANISH)	1	EP					
△ 314	VQT1X66	SIMPLIFIED O/I (POLISH/CZECH)	1	EP					
△ 314	VQT1X67	SIMPLIFIED O/I (HUNGARIAN/FINNISH)	1	EP					
△ 314	VQT1X73	SIMPLIFIED O/I (ARABIC/PERSIAN)	1	GC					
△ 314	VQT1X72	SIMPLIFIED O/I (ENGLISH/CHINESE(TRADITIONAL))	1	GC,GH,SG,GJ					
△ 314	VQT1X80	INSTRUCTION BOOK (KOREAN)	1	GD					
△ 314	VQT1X78	INSTRUCTION BOOK (CHINESE(SIMPLIFIED))	1	GK					
△ 314	VQT1X77	INSTRUCTION BOOK (CHINESE(TRADITIONAL))	1	GT					
315	VQT1W14	O/I SOFTWARE (SPANISH/PORTUGUESE)	1	PU					
315	VQT1W18	O/I SOFTWARE (ENGLISH)	1	EB					
315	VQT1W19	O/I SOFTWARE (RUSSIAN/UKRAINIAN)	1	EE					
315	VQT1W17	O/I SOFTWARE (FRENCH)	1	EF					
315	VQT1W15	O/I SOFTWARE (GERMAN/FRENCH/ITALIAN/ DUTCH/SPANISH/PORTUGUESE)	1	EG					

S7. Exploded View

S7.1. Frame and Casing Section

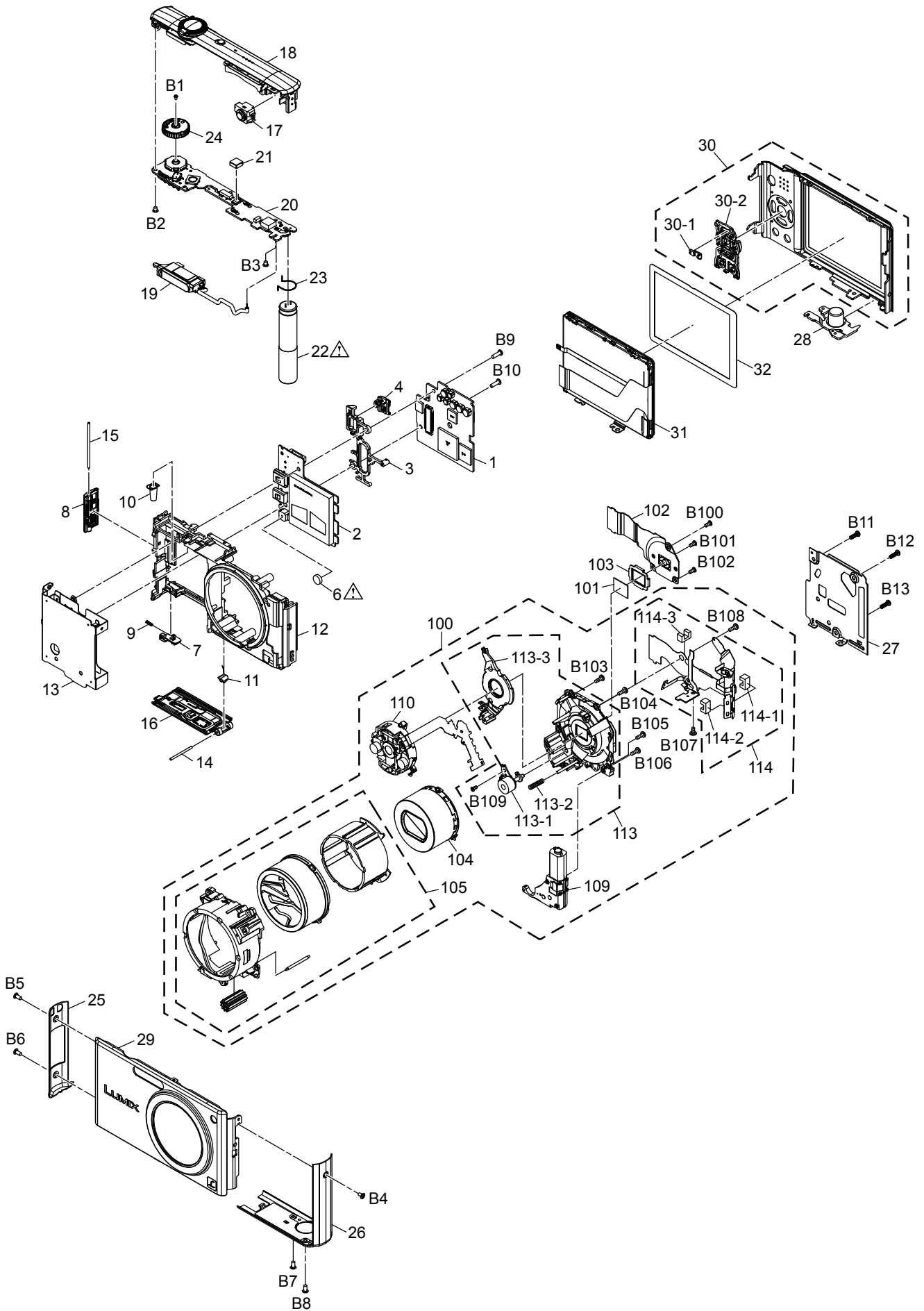

S7.2. Packing Parts and Accessories Section (1)

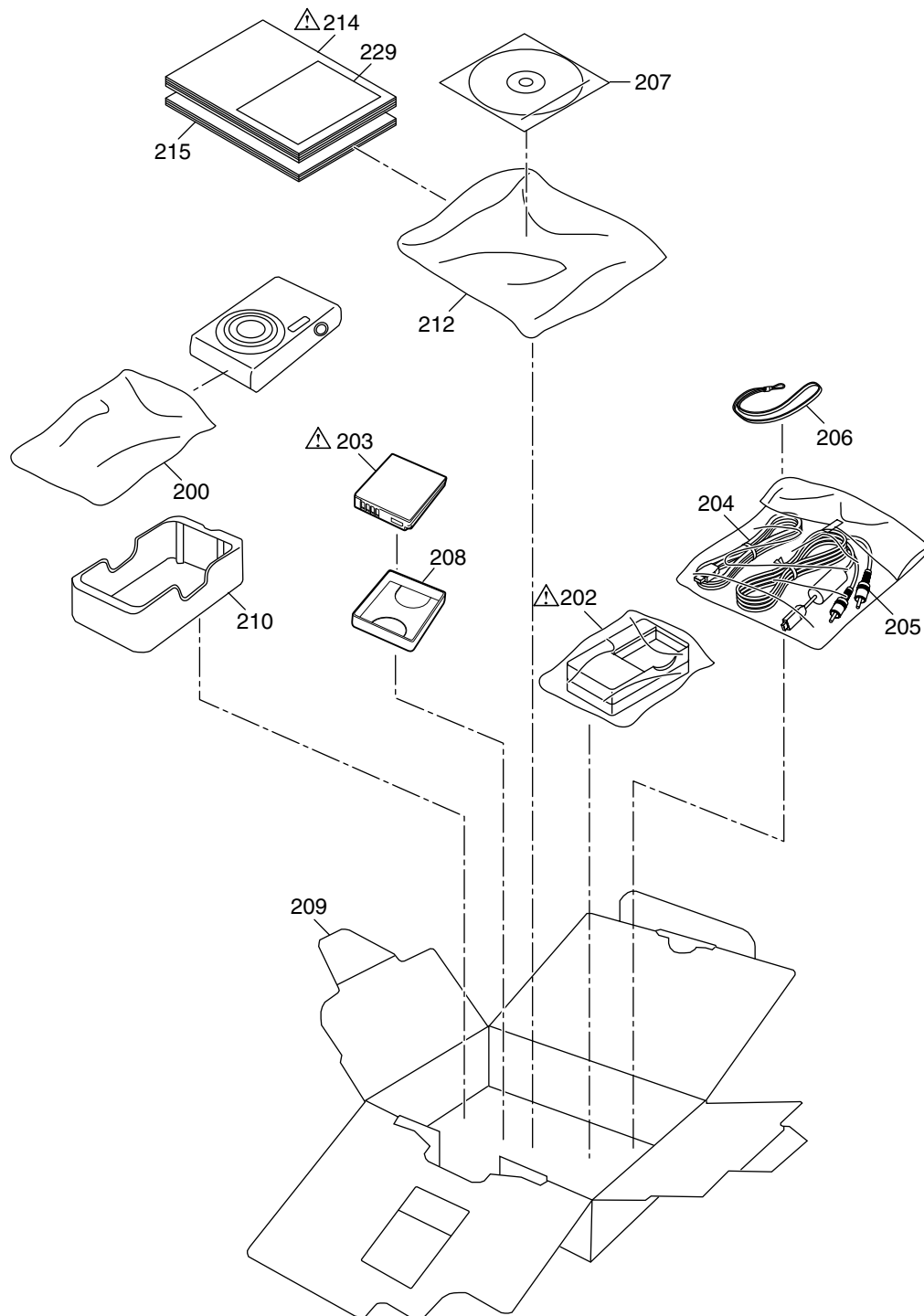

S7.3. Packing Parts and Accessories Section (2)

