

Service Manual

Digital Camera

LUMIX
LEICA
DC VARIO-ELMARIT



DMC-FX3PP
DMC-FX3PL
DMC-FX3EB
DMC-FX3EE
DMC-FX3EF
DMC-FX3EG
DMC-FX3EGM
DMC-FX3GC
DMC-FX3GD
DMC-FX3GK
DMC-FX3GN
DMC-FX3GT

Vol. 1

Colour

(S).....Silver Type

(K).....Black Type

⚠ WARNING

This service information is designed for experienced repair technicians only and is not designed for use by the general public. It does not contain warnings or cautions to advise non-technical individuals of potential dangers in attempting to service a product. Products powered by electricity should be serviced or repaired only by experienced professional technicians. Any attempt to service or repair the product or products dealt with in this service information by anyone else could result in serious injury or death.

Panasonic®

© 2006 Matsushita Electric Industrial Co., Ltd. All rights reserved. Unauthorized copying and distribution is a violation of law.

TABLE OF CONTENTS

	PAGE	PAGE
1 Safety Precaution	3	
1.1. General Guidelines	3	
1.2. Leakage Current Cold Check	3	
1.3. Leakage Current Hot Check (See Figure 1.)	3	
1.4. How to Discharge the Capacitor on Flash Top PCB	4	
2 Warning	5	
2.1. Prevention of Electro Static Discharge (ESD) to Electrostatically Sensitive (ES) Devices	5	
2.2. How to Recycle the Lithium Ion Battery (U.S. Only)	5	
2.3. Caution for AC Cord (For EB/GC)	6	
2.4. How to Replace the Lithium Battery	7	
3 Service Navigation	9	
3.1. Introduction	9	
3.2. General Description About Lead Free Solder (PbF)	9	
3.3. Important Notice 1: (Other than U.S.A. and Canadian Market)	9	
3.4. How to Define the Model Suffix (NTSC or PAL model)	10	
4 Specifications	12	
5 Location of Controls and Components	13	
6 Service Mode	14	
6.1. Error Code Memory Function	14	
6.2. Confirmation of Firmware Version	17	
7 Service Fixture & Tools	18	
7.1. Service Fixture and Tools	18	
7.2. When Replacing the Main PCB	19	
7.3. Service Position	19	
8 Disassembly and Assembly Instructions	20	
8.1. Disassembly Flow Chart	20	
8.2. PCB Location	20	
8.3. Disassembly Procedure	21	
8.4. Disassembly Procedure for the Lens	24	
8.5. Assembly Procedure for the Lens	27	
8.6. Removal of the CCD Unit	31	
8.7. The Application of Grease Method	31	
9 Measurements and Adjustments	32	
9.1. Matrix Chart for Replaced Part and Necessary Adjustment	32	
10 Maintenance	33	
10.1. Cleaning Lens and LCD Panel	33	

1 Safety Precaution

1.1. General Guidelines

1. IMPORTANT SAFETY NOTICE

There are special components used in this equipment which are important for safety. These parts are marked by

 in the Schematic Diagrams, Circuit Board Layout, Exploded Views and Replacement Parts List. It is essential that these critical parts should be replaced with manufacturer's specified parts to prevent X-RADIATION, shock, fire, or other hazards. Do not modify the original design without permission of manufacturer.

2. An Isolation Transformer should always be used during the servicing of AC Adaptor whose chassis is not isolated from the AC power line. Use a transformer of adequate power rating as this protects the technician from accidents resulting in personal injury from electrical shocks. It will also protect AC Adaptor from being damaged by accidental shorting that may occur during servicing.
3. When servicing, observe the original lead dress. If a short circuit is found, replace all parts which have been overheated or damaged by the short circuit.
4. After servicing, see to it that all the protective devices such as insulation barriers, insulation papers shields are properly installed.
5. After servicing, make the following leakage current checks to prevent the customer from being exposed to shock hazards.

1.2. Leakage Current Cold Check

1. Unplug the AC cord and connect a jumper between the two prongs on the plug.
2. Measure the resistance value, with an ohmmeter, between the jumpered AC plug and each exposed metallic cabinet part on the equipment such as screwheads, connectors, control shafts, etc. When the exposed metallic part has a return path to the chassis, the reading should be between $1\text{ M}\Omega$ and $5.2\text{ M}\Omega$. When the exposed metal does not have a return path to the chassis, the reading must be infinity.

1.3. Leakage Current Hot Check (See Figure 1.)

1. Plug the AC cord directly into the AC outlet. Do not use an isolation transformer for this check.
2. Connect a $1.5\text{ k}\Omega$, 10 W resistor, in parallel with a $0.15\text{ }\mu\text{F}$ capacitor, between each exposed metallic part on the set and a good earth ground, as shown in Figure 1.
3. Use an AC voltmeter, with $1\text{ k}\Omega/\text{V}$ or more sensitivity, to measure the potential across the resistor.
4. Check each exposed metallic part, and measure the voltage at each point.
5. Reverse the AC plug in the AC outlet and repeat each of the above measurements.
6. The potential at any point should not exceed 0.75 V RMS . A leakage current tester (Simpson Model 229 or equivalent) may be used to make the hot checks, leakage current must not exceed $1/2\text{ mA}$. In case a measurement is outside of the limits specified, there is a possibility of a shock hazard, and the equipment should be repaired and rechecked before it is returned to the customer.

Hot-Check Circuit

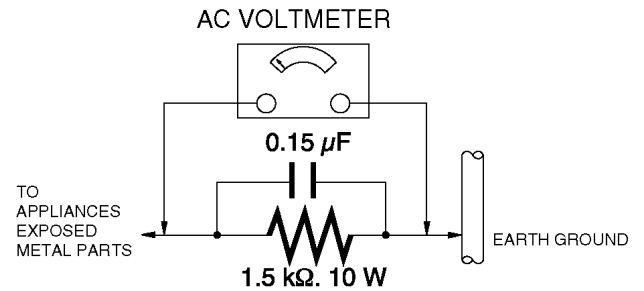

Figure. 1

1.4. How to Discharge the Capacitor on Flash Top PCB

CAUTION:

1. Be sure to discharge the capacitor on FLASH TOP PCB.
2. Be careful of the high voltage circuit on FLASH TOP PCB when servicing.

[Discharging Procedure]

1. Refer to the disassemble procedure and Remove the necessary parts/unit.
2. Put the insulation tube onto the lead part of Resistor (ERG5SJ102:1k Ω /5W).
(an equivalent type of resistor may be used.)
3. Put the resistor between both terminals of capacitor on FLASH TOP PCB for approx. 5 seconds.
4. After discharging confirm that the capacitor voltage is lower than 10V using a voltmeter.

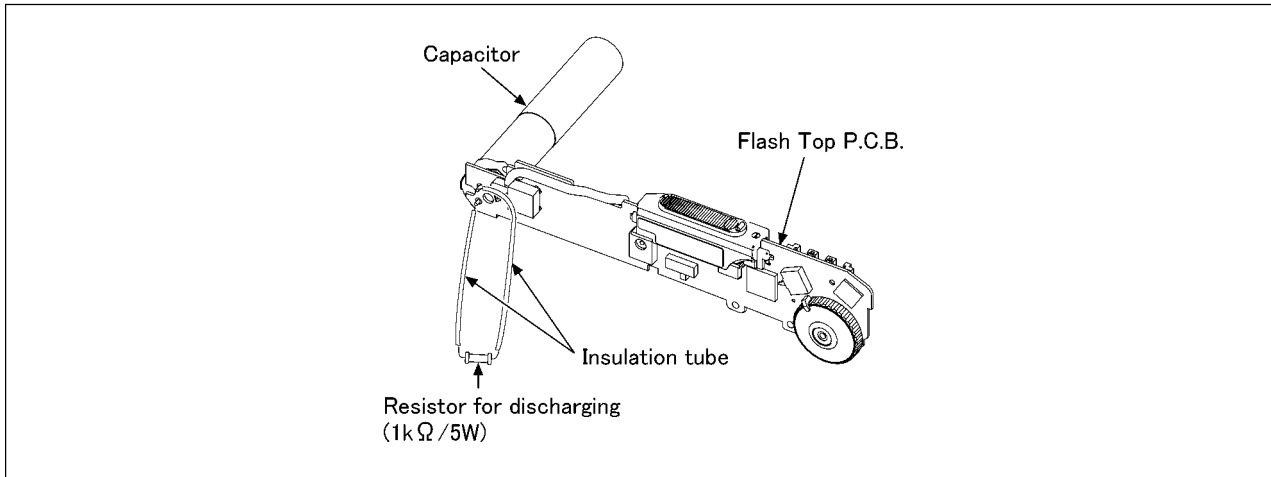

Fig. F1

2 Warning

2.1. Prevention of Electro Static Discharge (ESD) to Electrostatically Sensitive (ES) Devices

Some semiconductor (solid state) devices can be damaged easily by static electricity. Such components commonly are called Electrostatically Sensitive (ES) Devices.

Examples of typical ES devices are CCD image sensor, IC (integrated circuits) and some field-effect transistors and semiconductor "chip" components.

The following techniques should be used to help reduce the incidence of component damage caused by electro static discharge (ESD).

1. Immediately before handling any semiconductor component or semiconductor-equipped assembly, drain off any ESD on your body by touching a known earth ground. Alternatively, obtain and wear a commercially available discharging ESD wrist strap, which should be removed for potential shock reasons prior to applying power to the unit under test.
2. After removing an electrical assembly equipped with ES devices, place the assembly on a conductive surface such as aluminum foil, to prevent electrostatic charge buildup or exposure of the assembly.
3. Use only a grounded-tip soldering iron to solder or unsolder ES devices.
4. Use only an antistatic solder removal device. Some solder removal devices not classified as "antistatic (ESD protected)" can generate electrical charge sufficient to damage ES devices.
5. Do not use freon-propelled chemicals. These can generate electrical charges sufficient to damage ES devices.
6. Do not remove a replacement ES device from its protective package until immediately before you are ready to install it. (Most replacement ES devices are packaged with leads electrically shorted together by conductive foam, aluminum foil or comparable conductive material).
7. Immediately before removing the protective material from the leads of a replacement ES device, touch the protective material to the chassis or circuit assembly into which the device will be installed.

CAUTION :

Be sure no power is applied to the chassis or circuit, and observe all other safety precautions.

8. Minimize bodily motions when handling unpackaged replacement ES devices. (Otherwise harmless motion such as the brushing together of your clothes fabric or the lifting of your foot from a carpeted floor can generate static electricity (ESD) sufficient to damage an ES device).

2.2. How to Recycle the Lithium Ion Battery (U.S. Only)

ENGLISH



A lithium ion/polymer battery that is recyclable powers the product you have purchased. Please call 1-800-8-BATTERY for information on how to recycle this battery.

FRANÇAIS



L'appareil que vous vous êtes procuré est alimenté par une batterie au lithium-ion/polymère recyclable. Pour des renseignements sur le recyclage de la batterie, veuillez composer le 1-800-8-BATTERY.

2.3. Caution for AC Cord (For EB/GC)

2.3.1. Information for Your Safety

IMPORTANT

Your attention is drawn to the fact that recording of pre-recorded tapes or discs or other published or broadcast material may infringe copyright laws.

WARNING

To reduce the risk of fire or shock hazard, do not expose this equipment to rain or moisture.

CAUTION

To reduce the risk of fire or shock hazard and annoying interference, use the recommended accessories only.

FOR YOUR SAFETY

DO NOT REMOVE THE OUTER COVER

To prevent electric shock, do not remove the cover. No user serviceable parts inside. Refer servicing to qualified service personnel.

2.3.2. Caution for AC Mains Lead

For your safety, please read the following text carefully.

This appliance is supplied with a moulded three-pin mains plug for your safety and convenience.

A 5-ampere fuse is fitted in this plug.

Should the fuse need to be replaced please ensure that the replacement fuse has a rating of 5 amperes and it is approved by ASTA or BSI to BS1362

Check for the ASRA mark or the BSI mark on the body of the fuse.



If the plug contains a removable fuse cover you must ensure that it is refitted when the fuse is replaced.

If you lose the fuse cover, the plug must not be used until a replacement cover is obtained.

A replacement fuse cover can be purchased from your local Panasonic Dealer.

If the fitted moulded plug is unsuitable for the socket outlet in your home then the fuse should be removed and the plug cut off and disposed of safely.

There is a danger of severe electrical shock if the cut off plug is inserted into any 13-ampere socket.

If a new plug is to be fitted please observe the wiring code as shown below.

If in any doubt, please consult a qualified electrician.

2.3.2.1. Important

The wires in this mains lead are coloured in accordance with the following code:

Blue	Neutral
Brown	Live

As the colours of the wires in the mains lead of this appliance may not correspond with the coloured markings identifying the terminals in your plug, proceed as follows:

The wire which is coloured BLUE must be connected to the terminal in the plug which is marked with the letter N or coloured BLACK.

The wire which is coloured BROWN must be connected to the terminal in the plug which is marked with the letter L or coloured RED.

Under no circumstances should either of these wires be connected to the earth terminal of the three pin plug, marked with the letter E or the Earth Symbol.

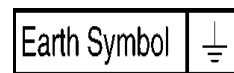

2.3.2.2. Before Use

Remove the Connector Cover as follows.

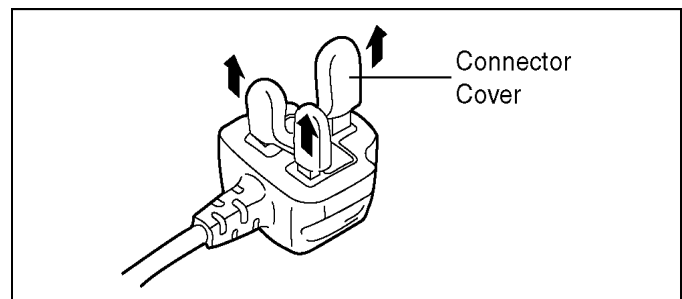

2.3.2.3. How to Replace the Fuse

1. Remove the Fuse Cover with a screwdriver.

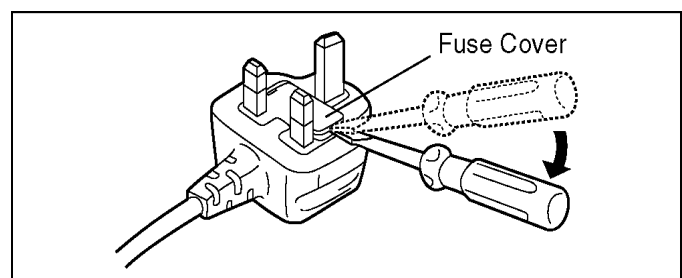

2. Replace the fuse and attach the Fuse cover.

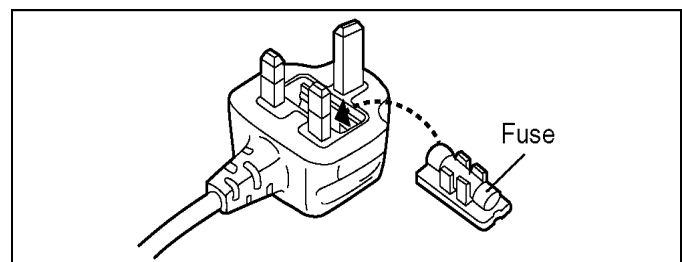

2.4. How to Replace the Lithium Battery

2.4.1. Replacement Procedure

1. Remove the SUB PCB. (Refer to Disassembly Procedures.)
2. Remove the Lithium battery (Ref. No. "Z9101" at component side of SUB PCB) and then replace it into new one.

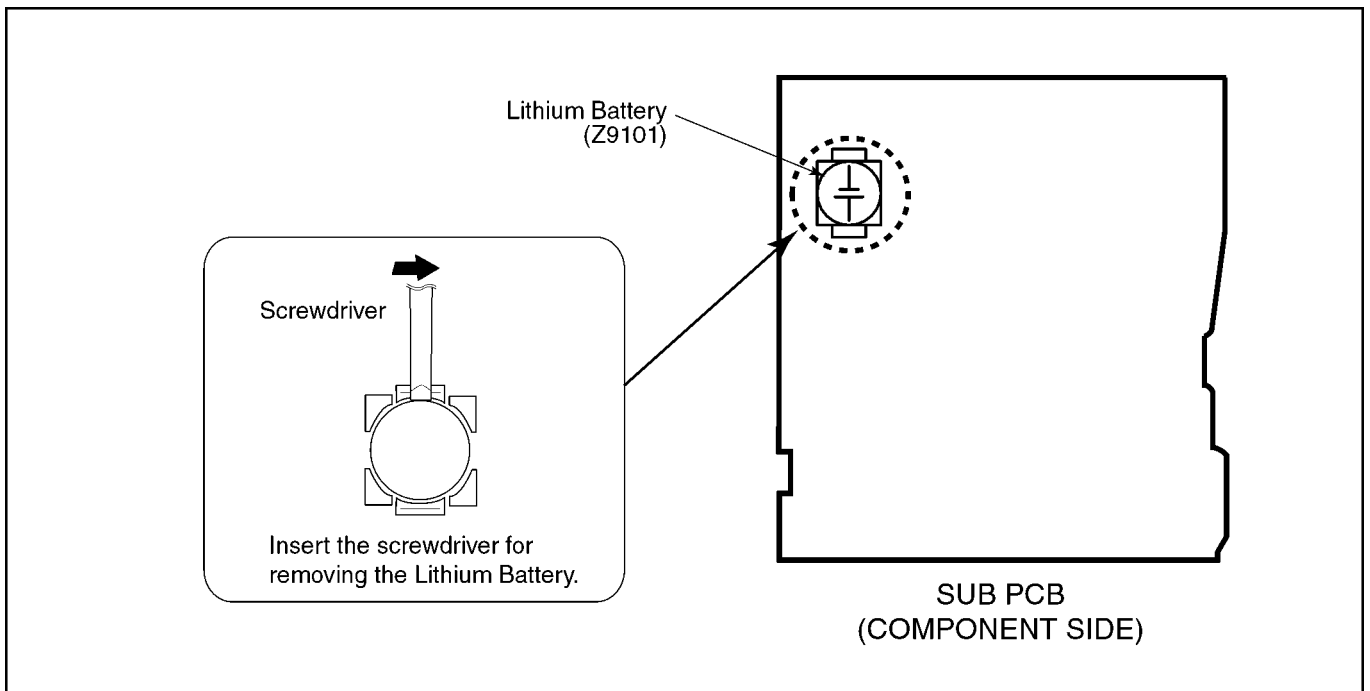

NOTE:

This Lithium battery is a critical component.

(Type No.: ML-421S/ZT **Manufactured by Matsushita Battery Industrial Co.,Ltd.**)

It must never be subjected to excessive heat or discharge.

It must therefore only be fitted in requirement designed specifically for its use.

Replacement batteries must be of same type and manufacture.

They must be fitted in the same manner and location as the original battery, with the correct polarity contacts observed.

Do not attempt to re-charge the old battery or re-use it for any other purpose.

It should be disposed of in waste products destined for burial rather than incineration.

(For English)

CAUTION

Danger of explosion if battery is incorrectly replaced.
Replace only with the same or equivalent type recommended by the manufacturer.
Dispose of used batteries according to the manufacturer's instructions.

(For French)

PRECAUTION

Le fait de remplacer incorrectement la pile peut présenter des risques d'explosion.
Remplacer la pile uniquement par une pile identique ou de type équivalent recommandée par le fabricant. Se débarrasser des piles usagées conformément aux instructions du fabricant.

(For German)

VORSICHT

Bei einer falsch eingesetzten Batterie besteht Explosionsgefahr. Nur mit einer vom Hersteller empfohlenen Batterie vom gleichen Typ ersetzen.
Verbrauchte Batterien beim Fachhändler oder einer Sammelstelle für Sonderstoffe abliefern.

(For Swedish)

VARNING

Explosionsfara vid felaktigt batteribyte.
Använd samma batterityp eller en ekvivalent typ som rekommenderas av apparatillverkaren.
Kassera använt batteri enligt fabrikantens instruktion.

(For Norwegian)

ADVARSEL!

Lithiumbatteri-Eksplosionsfare ved fejløst håndtering.
Udskiftning må kun ske med batteri af samme fabrikat og type.
Levér det brugte batteri tilbage til leverandøren.

(For Finnish)

VAROITUS

Paristo voi räjähtää, jos se on virheellisesti asennettu.
Vaihda paristo ainoastaan laitevalmistajan suosittelemaan tyyppiin.
Hävitä käytetty paristo valmistajan ohjeiden mukaisesti.

NOTE:

Above caution is applicable for a battery pack which is for DMC-FX3 series, as well.

3 Service Navigation

3.1. Introduction

This service manual contains technical information, which allow service personnel's to understand and service this model. Please place orders using the parts list and not the drawing reference numbers. If the circuit is changed or modified, the information will be followed by service manual to be controlled with original service manual.

3.2. General Description About Lead Free Solder (PbF)

The lead free solder has been used in the mounting process of all electrical components on the printed circuit boards used for this equipment in considering the globally environmental conservation. The normal solder is the alloy of tin (Sn) and lead (Pb). On the other hand, the lead free solder is the alloy mainly consists of tin (Sn), silver (Ag) and Copper (Cu), and the melting point of the lead free solder is higher approx.30°C (86°F) more than that of the normal solder.

Distinction of PCB Lead Free Solder being used

The letter of "PbF" is printed either foil side or components side on the PCB using the lead free solder.(See right figure)	PbF
---	-----

Service caution for repair work using Lead Free Solder (PbF)

- The lead free solder has to be used when repairing the equipment for which the lead free solder is used. (Definition: The letter of "PbF" is printed on the PCB using the lead free solder.)
- To put lead free solder, it should be well molten and mixed with the original lead free solder.
- Remove the remaining lead free solder on the PCB cleanly for soldering of the new IC.
- Since the melting point of the lead free solder is higher than that of the normal lead solder, it takes the longer time to melt the lead free solder.
- Use the soldering iron (more than 70W) equipped with the temperature control after setting the temperature at 350±30°C (662±86°F).

Recommended Lead Free Solder (Service Parts Route.)

- The following 3 types of lead free solder are available through the service parts route.
 - RFKZ03D01K----- (0.3mm 100g Reel)
 - RFKZ06D01K----- (0.6mm 100g Reel)
 - RFKZ10D01K----- (1.0mm 100g Reel)

Note

* Ingredient: tin (Sn) 96.5%, silver (Ag) 3.0%, Copper (Cu) 0.5%, Cobalt (Co) / Germanium (Ge) 0.1 to 0.3%

3.3. Important Notice 1:(Other than U.S.A. and Canadian Market)

1. The service manual does not contain the following information, because of the impossibility of servicing at component level without concerned equipment/facilities.
 - a. Schematic diagram, Block Diagram and PCB layout of MAIN PCB and SUB PCB.
 - b. Parts list for individual parts for MAIN PCB and SUB PCB.When a part replacement is required for repairing MAIN PCB and/or SUB PCB, replace as an assembled parts. (Main PCB/ SUB PCB)
2. The following category is/are recycle module part. please send it/them to Central Repair Center.
 - MAIN PCB (VEP56039A)
 - SUB PCB (VEP51009A) : Excluding replacement of Lithium Battery

3.4. How to Define the Model Suffix (NTSC or PAL model)

There are seven kinds of DMC-FX3, regardless of the colours.







- a) DMC-FX3S
- b) DMC-FX3PP
- c) DMC-FX3EB/EF/EG/EGM/GN
- d) DMC-FX3EE
- e) DMC-FX3GD
- f) DMC-FX3GT
- g) DMC-FX3PL/GC/GK

(DMC-FX3S is exclusively Japan domestic model.)

What is the difference is that the "INITIAL SETTINGS" data which is stored in Flash ROM mounted on Main PCB.

3.4.1. Defining methods:

To define the model suffix to be serviced, refer to the nameplate which is putted on the bottom side of the Unit.

<p>a) DMC-FX3S DMC-FX3S is exclusively Japan domestic model.</p> <p>b) DMC-FX3PP The nameplate for this model show the following Safty registration mark.</p> 	 <p>Safty registration mark</p>
<p>c) DMC-FX3EB/EF/EG/EGM/GN The nameplate for these models show the following Safty registration mark.</p> 	
<p>d) DMC-FX3EE The nameplate for this model show the following Safty registration mark.</p> 	
<p>e) DMC-FX3GD The nameplate for this model show the following Safty registration mark.</p> 	
<p>f) DMC-FX3GT The nameplate for this model show the following Safty registration mark.</p> 	
<p>g) DMC-FX3PL/GC/GK The nameplate for these models do not show any above Safty registration mark.</p>	

NOTE:

After replacing the MAIN PCB, be sure to achieve adjustment.

The adjustment instruction is available at "software download" on the "Support Information from NWBG/VDBG-PAVC" web-site in "TSN system", together with Maintenance software.

3.4.2. INITIAL SETTINGS:

CAUTION:

The unit employs "Built-in Memory" for picture image data recording. (Approx. 13.5MB)
 Be sure to make picture data back up (i.e., Copying to SD memory card), before proceeding "INITIAL SETTINGS".
 Once "INITIAL SETTINGS" has been carried out, all image data belong to "Built-in Memory" shall be erased.

CAUTION:

NEVER select "NONE(JAPAN)" if the unit is other than "JAPAN" model.
 Other-wise, it can not be reset to the others.

When you replace the Main PCB be sure to perform the initial settings after achieving the Adjustment, by ordering the following procedure in accordance with model suffix.

• **Step 1. The temporary cancellation of factory setting:**

Set the mode dial to "[Normal picture mode] (Red camera mark)".

While keep pressing [Optical Image Stabilizer] and "[UP] of Cross key" simultaneously, turn the Power on.

• **Step 2. The cancellation of factory setting:**

Set the mode dial to "[Playback]".

Press [Optical Image Stabilizer] and "[UP] of Cross key" simultaneously, then turn the Power off.

• **Step 3. Turn the Power on:**

Set the mode dial to "[Normal picture mode] (Red camera mark)", and then turn the Power on.

• **Step 4. Display the INITIAL SETTING:**

While keep pressing [MENU] and "[RIGHT] of Cross key" simultaneously, turn the Power off.

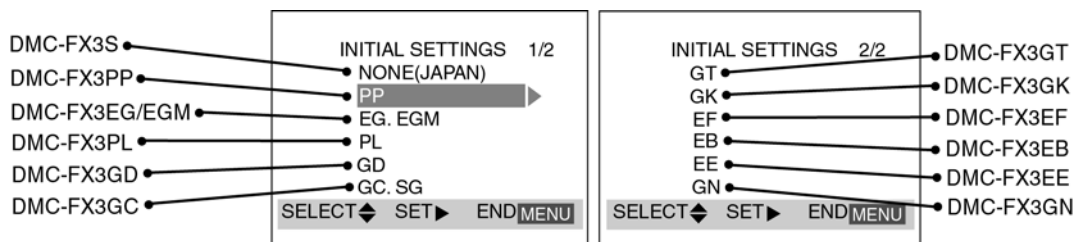

• **Step 5. Set the INITIAL SETTING:**

Select the area with pressing "[UP] / [DOWN] of Cross key", and then press the "[RIGHT] of Cross key".

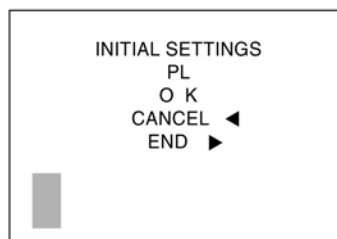

The only set area is displayed, and then press the "[RIGHT] of Cross key" after confirmation.
 (The unit is powered off automatically.)

Confirm the display of "PLEASE SET THE CLOCK" in English when the unit is turned on again.

• **Step 6. CONFIRMATION:**

The display shows "PLEASE SET THE CLOCK" when turn the Power on again.

When the unit is connected to PC with USB cable, it is detected as removable media.

(When the "GT" or "GK" model suffix is selected, the display shows "PLEASE SET THE CLOCK" in Chinese.)

1) As for your reference Default setting condition is given in the following table.

• **Default setting (After "INITIAL SETTINGS")**

	MODEL	VIDEO OUTPUT	LANGUAGE	DATE	REMARKS
a)	DMC-FX3S	NTSC	Japanese	Year/Month/Date	
b)	DMC-FX3PP/PL	NTSC	English	Month/Date/Year	
c)	DMC-FX3EB/EE/EF/EG/EGM/GC/GN	PAL	English	Date/Month/Year	
d)	DMC-FX3GK	PAL	Chinese (simplified)	Year/Month/Date	
e)	DMC-FX3GT	NTSC	Chinese (traditional)	Year/Month/Date	
f)	DMC-FX3GD	NTSC	English	Year/Month/Date	

4 Specifications

Digital Camera:	Information for your safety
Power Source:	DC 5.1 V
Power Consumption:	1.6 W (When recording) 0.8 W (When playing back)
Camera effective pixels:	6,000,000 pixels
Image sensor:	1/2.5" CCD, total pixel number 6,370,000 pixels, Primary color filter
Lens:	Optical 3.0× zoom, f=5.8 mm to 17.4 mm (35 mm film camera equivalent: 35 mm to 105 mm)/F2.8 to F5.0
Digital zoom:	Max. 4×
Extended optical zoom:	Max. 4.1×
Focus:	Normal/Macro, 5-area-focusing /3-area-focusing (High speed)/1-area-focusing (High speed)/1-area-focusing/Spot-focusing
Focus range:	Normal: 50 cm (1.64 feet) to ∞ Macro/Simple/Motion picture: 5 cm (0.16 feet) (Wide)/30 cm (0.98 feet) (Tele) to ∞
Shutter system:	Electronic shutter+Mechanical shutter
Burst recording	
Burst speed:	3 pictures/second (High speed), 2 pictures/second (Low speed), Approx. 1.5 pictures/second (Unlimited)
Number of recordable pictures:	Max. 8 pictures (Standard), max. 6 pictures (Fine), Depends on the remaining capacity of the built-in memory or the card (Unlimited). (Performance in burst recording is only with SD Memory Card/SDHC Memory Card. MultiMediaCard performance will be less.)
Motion picture recording:	848×480 pixels/640×480 pixels/320×240 pixels (30 or 10 frames/second with audio. The maximum recording time depends on the capacity of the built-in memory or the card.)
ISO sensitivity:	AUTO/100/200/400 [HIGH SENS.] mode: 800 to 1600
Shutter speed:	8 seconds to 1/2000th of a second [STARRY SKY] mode: 15 seconds, 30 seconds, 60 seconds Motion picture mode: 1/30th of a second to 1/2000th of a second
White balance:	AUTO/Daylight/Cloudy/Shade/Halogen/White set
Exposure (AE):	Program AE Exposure compensation (1/3 EV Step, -2 EV to +2 EV)
Metering mode:	Multiple
LCD monitor:	2.5" TFT LCD [Approx. 115,000 pixels] (field of view ratio about 100%)
Flash:	Flash range: [ISO AUTO] Approx. 30 cm (0.98 feet) to 4 m (13.1 feet) (Wide) [HIGH SENS.] mode: Approx. 80 cm (2.62 feet) to 5.7 m (18.7 feet) (Wide) AUTO, AUTO/Red-eye reduction, Forced ON (Forced ON/Red-eye reduction), Slow sync/Red-eye reduction, Forced OFF
Microphone:	Monaural
Speaker:	Monaural

Recording media:	Built-in Memory (Approx. 13.5 MB)/ SD Memory Card/SDHC Memory Card/MultiMediaCard (Still pictures only)
Picture size	
Still picture:	When the aspect ratio setting is [4:3] 2816×2112 pixels, 2048×1536 pixels, 1600×1200 pixels, 1280×960 pixels, 640×480 pixels When the aspect ratio setting is [3:2] 2816×1880 pixels, 2048×1360 pixels When the aspect ratio setting is [16:9] 2816×1584 pixels, 1920×1080 pixels
Motion pictures:	When the aspect ratio setting is [4:3] 640×480 pixels, 320×240 pixels When the aspect ratio setting is [16:9] 848×480 pixels Fine/Standard
Quality:	
Recording file format	
Still Picture:	JPEG (based on "Design rule for Camera File system", based on "Exif 2.21" standard)/DPOF corresponding
Picture with audio:	JPEG (based on "Design rule for Camera File system", based on "Exif 2.21" standard)+ "QuickTime" (picture with audio) "QuickTime Motion JPEG" (motion pictures with audio)
Motion pictures:	
Interface	
Digital:	"USB 2.0" (Full Speed)
Analog video/audio:	NTSC/PAL Composite (Switched by menu), Audio line output (monaural)
Terminal	
[DIGITAL/AV OUT]:	Dedicated jack (8 pin)
[DC IN]:	Dedicated jack
Dimensions:	Approx. 94.1 mm (W)×51.1 mm (H)×24.2 mm (D) [3 11/16" (W)×2 (H)×15/16" (D)] (excluding the projecting part)
Mass:	Approx. 125 g/4.41 oz (excluding card and battery), Approx. 153 g/5.40 oz (with card and battery)
Operating temperature:	0 °C to 40 °C (32 °F to 104 °F)
Operating humidity:	10% to 80%

Battery Charger (Panasonic DE-A11B): Information for your safety

Input:	110 V to 240 V~50/60 Hz, 0.2 A
Output:	CHARGE 4.2 V---0.8 A

Equipment mobility: Movable

Battery Pack (Lithium-Ion) (Panasonic CGA-S005A): Information for your safety

Voltage/capacity:	3.7 V, 1150 mAh
--------------------------	-----------------

5 Location of Controls and Components

Names of the Components

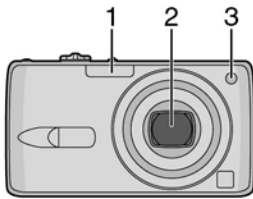

- 1 Flash
- 2 Lens
- 3 Self-timer indicator
AF assist lamp

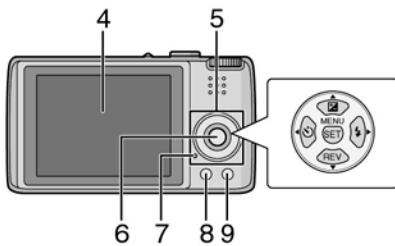

- 4 LCD monitor
- 5 Cursor buttons
 - ◀/Self-timer button
 - ▼/[REV] button
 - ▶/Flash setting button
 - ▲/Exposure compensation/Auto bracket/White balance fine adjustment/Backlight compensation in simple mode button
- 6 [MENU/SET] button
- 7 Status indicator
- 8 [DISPLAY/LCD MODE] button
- 9 Single or burst mode/
Delete button

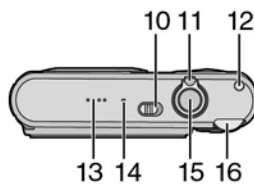

- 10 Camera ON/OFF switch
- 11 Zoom lever
- 12 Optical image stabilizer button
- 13 Speaker
- 14 Microphone
- 15 Shutter button
- 16 Mode dial

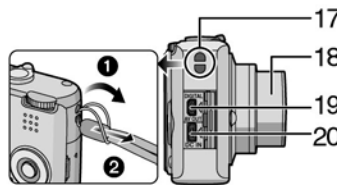

- 17 Strap eyelet
- 18 Lens barrel
- 19 [DIGITAL/AV OUT] socket
- 20 [DC IN] socket
 - Always use a genuine Panasonic AC adaptor (DMW-AC5; optional).
 - This camera cannot charge the battery even though the AC adaptor (DMW-AC5; optional) is connected to it.

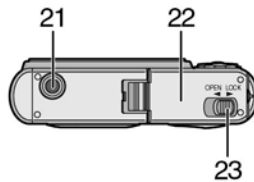

- 21 Tripod receptacle
 - When you use a tripod, make sure the tripod is stable when the camera is attached to it.
- 22 Card/Battery door
- 23 Release lever

About The Mode Dial

Adjust part (A) to the desired mode. Rotate the mode dial slowly and surely to adjust to each mode.

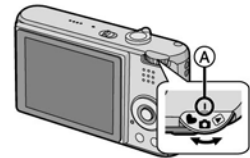

: Normal picture mode

Use this mode for normal recording.

: Macro mode

This mode allows you to take a close-up picture of a subject.

: Motion picture mode

This mode allows you to record motion pictures.

: Scene mode

This mode allows you to take pictures depending on the recording scenes.

: Simple mode

This mode is recommended for beginners.

: Playback mode

This mode allows you to play back recorded pictures.

6 Service Mode

6.1. Error Code Memory Function

1. General description

This unit is equipped with history of error code memory function, and can be memorized 32 error codes in sequence from the latest. When the error is occurred more than 32, the oldest error is overwritten in sequence.

The error code is not memorized when the power supply is shut down forcibly (when the unit is powered on by the battery, the battery is pulled out) because the error code is memorized to FLASH ROM when the unit is powered off.

2. How to display

The error code can be displayed by the following procedure:

Before perform the error code memory function, connect the AC adaptor or insert the battery.

Since this unit has build-in memory, this error code memory function can be performed without inserting SD card.

• 1. The temporary cancellation of factory setting:

Set the mode dial to "[Normal picture mode] (Red camera mark)".

While keep pressing [Optical Image Stabilizer Button] and "[UP] of Cross key" simultaneously, turn the Power on.

• 2. The display of error code:

Press [Optical Image Stabilizer Button], [MENU] and "[LEFT] of Cross key" simultaneously with the step 1 condition.

The display is changed as shown below when the above buttons is pressed simultaneously.

Normal display → Error code display → Operation history display → Normal display →

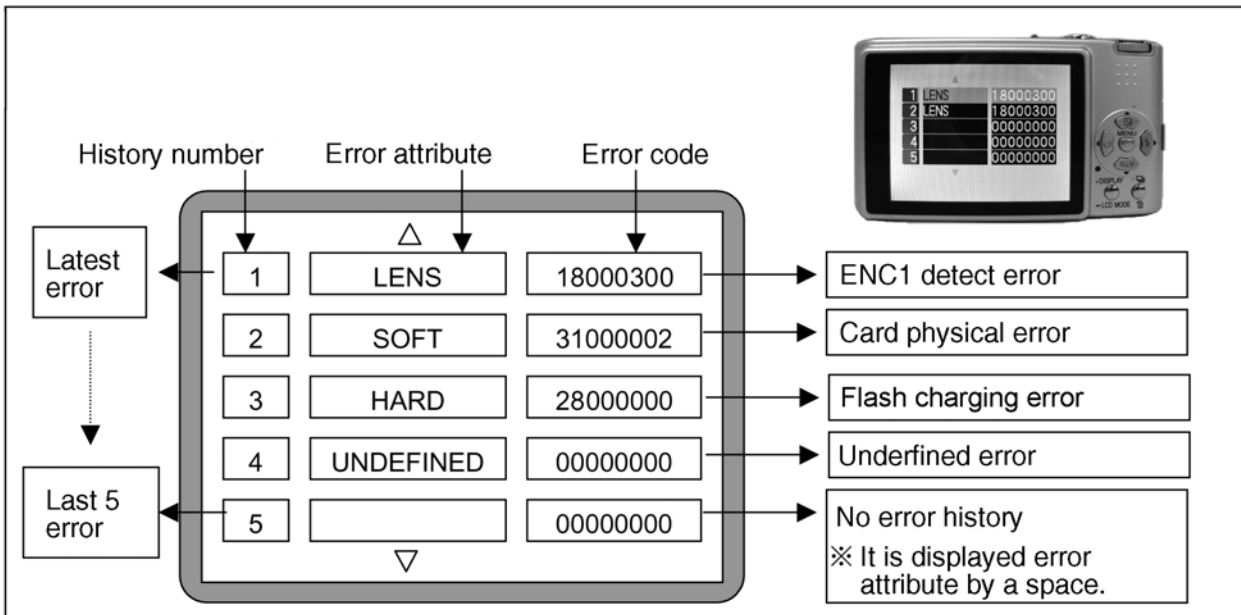

• 3. The change of display:

The error code can be memorized 32 error codes in sequence, however it is displayed 5 errors on the LCD.

Display can be changed by the following procedure:

"[UP] or [DOWN] of Cross key" : It can be scroll up or down one.

"[LEFT] or [RIGHT] of Cross key" : It can be display last 5 error or another 5 error.

• 4. How to read the error code:

One error code is displayed for 8 bit, the contents of error codes is indicated the table as shown below.

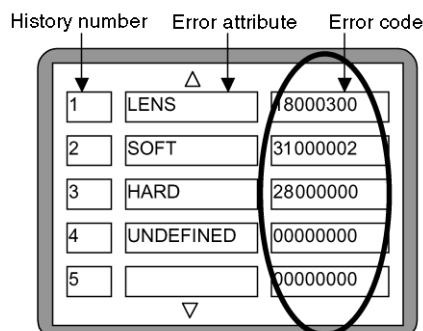

Attribute	Main item	Sub item	Error code		Contents (Upper)				
			High 4 bits	Low 4 bits	Check point (Lower)				
LENS	Lens drive	OIS	1800	1000	PSD (X) error. Hall element (X axis) position detect error in OIS unit. OIS Unit				
				2000	PSD (Y) error. Hall element (Y axis) position detect error in OIS unit. OIS Unit				
				3000	GYRO (X) error. Gyro (IC7101: X axis) detect error on Main P.C.B.. IC7101 (Gyro element) or IC6001 (VENUS PLUS)				
				4000	GYRO (Y) error. Gyro (IC7101: Y axis) detect error on Main P.C.B.. IC7101 (Gyro element) or IC6001 (VENUS PLUS)				
				5000	MREF error (Reference voltage error). IC7001 (LENS drive) or IC6001 (VENUS PLUS)				
				6000	Drive voltage (X) error. VENUS PLUS AD value error, LENS Unit, LENS flex breaks etc.				
			7000	Drive voltage (Y) error. VENUS PLUS AD value error, LENS Unit, LENS flex breaks etc.					
			C.B./Zoom	0100	HP Low detect error (C.B. encoder (full retract) always Low detect). FP9802-(14,16) signal line or IC6001 (VENUS PLUS)				
				0200	HP High detect error (C.B. encoder (full retract) always High detect). FP9802-(13,15) signal line or IC6001 (VENUS PLUS)				
				0300	ENC1 detect error (C.B. motor encoder detect error).				
				0400	ENC2 detect error (C.B. motor encoder detect error).				
				Focus	0001	HP Low detect error (Focus encoder always Low detect error). FP9802-(11) signal line or IC6001 (VENUS PLUS)			
		0002			HP High detect error (Focus encoder always High detect error). FP9802-(9) signal line or IC6001 (VENUS PLUS)				
		Lens	1801	0000	Power ON time out error. Lens drive system				
				0000	Power OFF time out error. Lens drive system				
		Adj.History	OIS	1900	2000	OIS adj. Yaw direction amplitude error (small)			
					3000	OIS adj. Pitch direction amplitude error (small)			
					4000	OIS adj. Yaw direction amplitude error (large)			
					5000	OIS adj. Pitch direction amplitude error (large)			
					6000	OIS adj. MREF error			
					7000	OIS adj. time out error			
					8000	OIS adj. Yaw direction off set error			
					9000	OIS adj. Pitch direction off set error			
					A000	OIS adj. Yaw direction gain error			
	B000				OIS adj. Pitch direction gain error				
	C000				OIS adj. Yaw direction position sensor error				
	D000				OIS adj. Pitch direction position sensor error				
	E000				OIS adj. other error				
	HARD				VENUS A/D	Flash	2800	0000	Flash charging error. IC6001-(13) signal line or Flash charging circuit
					FLASH ROM (EEPROM Area)	FLASH ROM (EEPROM Area)	2B00	0001	EEPROM read error IC6002 (FLASH ROM)
		0002	EEPROM write error IC6002 (FLASH ROM)						
		SYSTEM	RTC	2C00	0001	SYSTEM IC initialize error Communication between IC6001 (VENUS PLUS) and IC9101 (SYSTEM)			

Attribute	Main item	Sub item	Error code		Contents (Upper)		
			High 4 bits	Low 4 bits	Check point (Lower)		
SOFT	CPU	Reset	3000	0001	NMI reset		
				0007	Non Mask-able Interrupt (30000001-30000007 are caused by factors)		
	Card	Card	3100	0001	Card logic error SD card data line or IC6001 (VENUS PLUS)		
				0002	Card physical error SD card data line or IC6001 (VENUS PLUS)		
				0004	Write error SD card data line or IC6001 (VENUS PLUS)		
				3900	0005	Format error	
				CPU, ASIC hard	Stop	3800	0001
	0002	Camera task invalid code error. IC6001 (VENUS PLUS)					
	0100	File time out error in recording motion image IC6001 (VENUS PLUS)					
	0200	File data send error in recording motion image IC6001 (VENUS PLUS)					
	0300	Single or burst recording brake time out					
	Operation	Power on	3B00	0000	FLASHROM processing early period of camera during movement.		
	Zoom	Zoom	3C00	0000	I do not complete zoom lens processing Zoom lens		
					3500	0000	I jumped into dummy processing (0-7bit : command, 8-15bit : Status)
					3501	0000	Though record preprocessing is necessary, it is not called.
					3502	0000	Though record preprocessing is necessary, it is not completed.

• **5. How to returned to Normal Display:**

Turn the power off and on, to exit from Error code display mode.

NOTE:

The error code can not be initialized.

6.2. Confirmation of Firmware Version

The Firmware version can be confirmed by ordering the following steps:

- **Step 1. The temporary cancellation of factory setting:**

Set the mode dial to “[Normal picture mode] (Red camera mark)”.

Insert the SD memory card which has a few photo data.

While keep pressing [Optical Image Stabilizer] and “[UP] of Cross key” simultaneously, then turn the power on.

- **Step 2. Confirm the version:**

Set the mode dial to “[Playback]” and then press [DISPLAY] to switch to LCD with indication. (Fig. A)

Press [Optical Image Stabilizer] and “[DOWN] of Cross key” simultaneously. (No need to keep pressing.)

(The version information is displayed on the LCD with green colour letters.) (Fig. B)

CAUTION:

The version information does not display if the LCD has switched to LCD with indication already.

In this case, press [DISPLAY] to switch to LCD with indication.

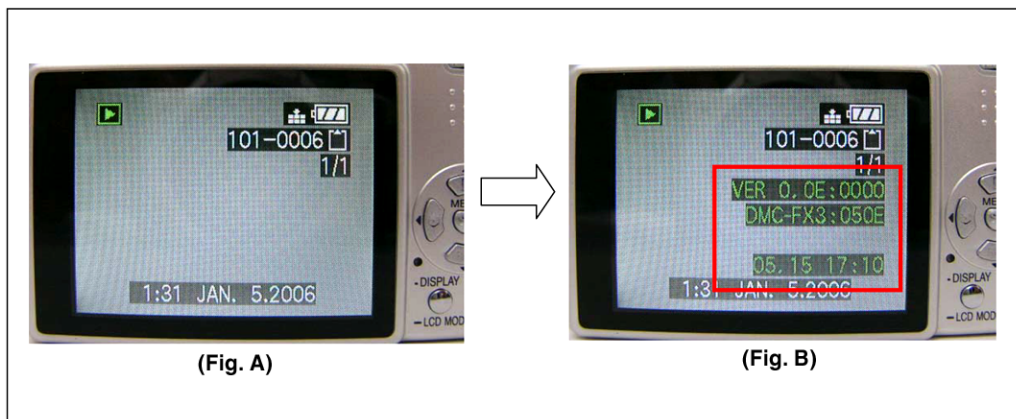
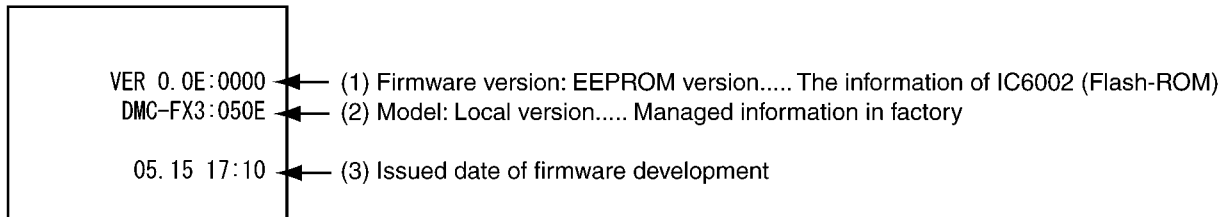







<Point>

- The firmware version and EEPROM version can be confirmed with the information (1).
- The information (2), (3) are just reference.

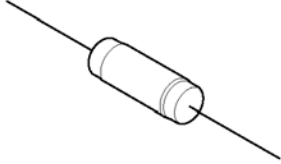
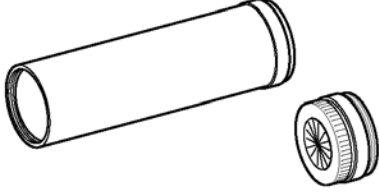
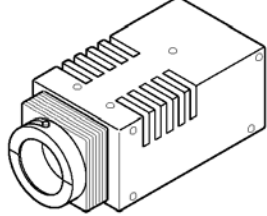
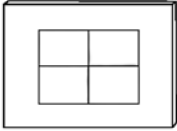
7 Service Fixture & Tools

7.1. Service Fixture and Tools

The following Service Fixture and tools are used for checking and servicing this unit.

Resistor for Discharging ERG5SJ102	Infinity Lens (with Focus Chart) VFK1164TCM02	LIGHT BOX VFK1164TDVLB
 An equivalent type of Resistor may be used.		 ※ with DC Cable
TR Chart VFK1975	Lens Cleaning Kit (BK) VFK1900BK	Grease (for lens) VFK1829
	 * Only supplied as 10 set/box.	
Furoyl grease (for focus motor) VFK1850	T3 Torx Driver RFKZ0334	ND Filter ND0.1 Type VFK1164ND01
		 An equivalent type of Filter may be used.

7.2. When Replacing the Main PCB

After replacing the MAIN PCB, be sure to achieve adjustment.

The adjustment instruction is available at “software download” on the “Support Information from NWBG/VDBG-PAVC” web-site in “TSN system”, together with Maintenance software.

7.3. Service Position

This Service Position is used for checking and replacing parts. Use the following Extension cables for servicing.

Table S1 Extension Cable List

No.	Parts No.	Connection	Form
1	VFK1951	FP9001 (MAIN) - LCD UNIT	39PIN 0.3 FFC
2	VFK1974	FP9002 (MAIN) - LCD UNIT	4PIN 0.5 FFC
3	VFK1950	FP9801 (SUB) - CCD UNIT	33PIN 0.3 FFC
4	VFK1951	FP9802 (SUB) - LENS UNIT	39PIN 0.3 FFC
5	RFKZ0362	PP9001 (MAIN) - PS9801 (SUB)	100PIN B to B
6	VFK1541	PP9802 (SUB) - PS8001 (FLASH TOP)	40PIN B to B

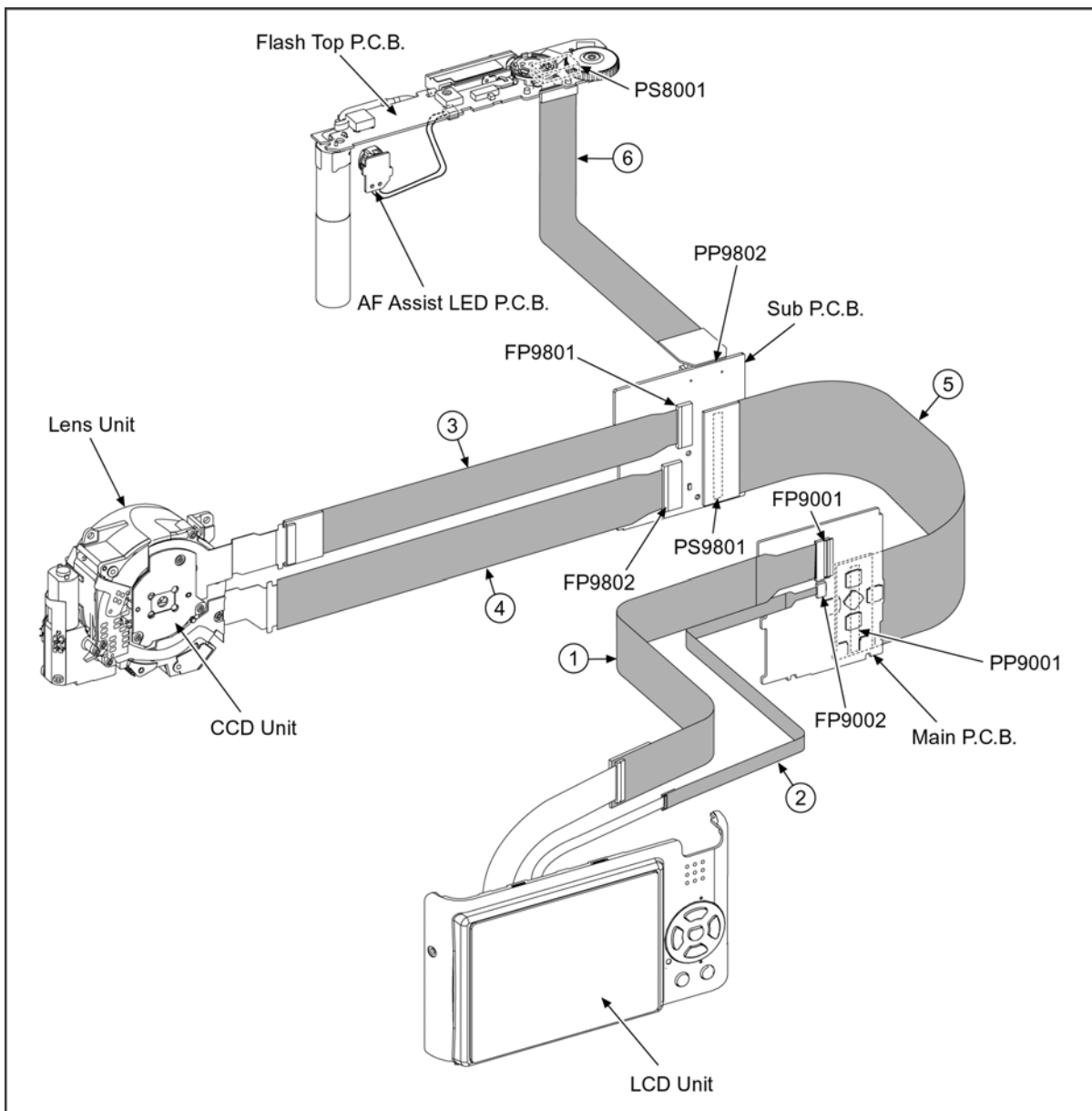

CAUTION-1. (When servicing FLASH TOP PCB)

1. Be sure to discharge the capacitor on FLASH TOP PCB.
Refer to “HOW TO DISCHARGE THE CAPACITOR ON FLASH TOP PCB”.
The capacitor voltage is not lowered soon even if the AC Cord is unplugged or the battery is removed.
2. Be careful of the high voltage circuit on FLASH TOP PCB.
3. DO NOT allow other parts to touch the high voltage circuit on FLASH TOP PCB.

8 Disassembly and Assembly Instructions

8.1. Disassembly Flow Chart

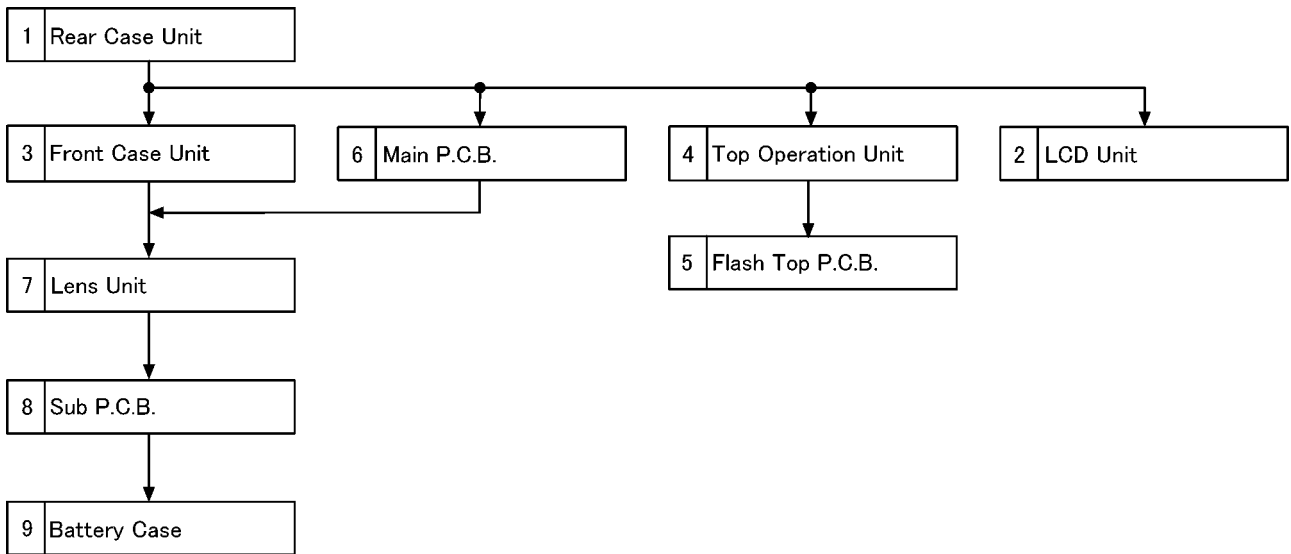

8.2. PCB Location

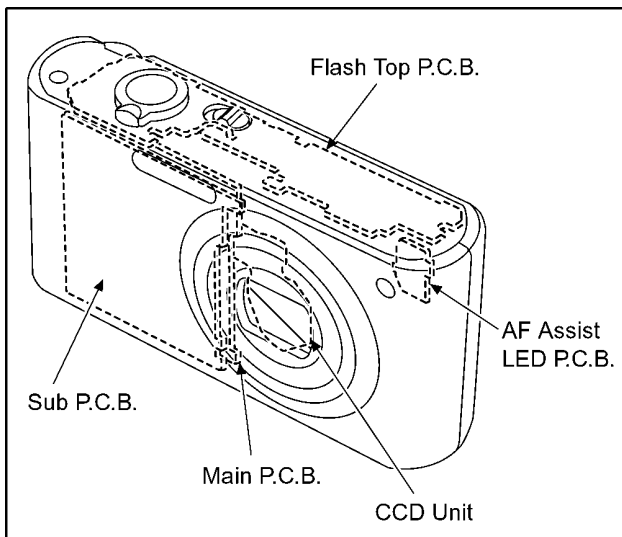

8.3. Disassembly Procedure

No.	Item	Fig	Removal
1	Rear Case Unit	(Fig. D1)	Card
			Battery
			4 Screws (A)
			FP9001(Flex)
			FP9002(Flex)
	Rear Case Unit		
2	LCD Unit	(Fig. D2)	2 Locking tabs
			LCD Unit
3	Front Case Unit	(Fig. D3)	5 Screws (B)
			3 Screws (C)
			Tripod Fixing Plate
			Front Case Unit
4	Top Operation Unit	(Fig. D4)	PS8001(Connector)
			Top Operation Unit
5	Flash Top P.C.B.	(Fig. D5)	2 Screws (D)
			6 Locking tabs
			Top Operation Unit
			Power knob
			P8001(Connector)
			Flash Cover
			Flash Top P.C.B.
		(Fig. D6)	Discharge the capacitor
6	Main P.C.B.	(Fig. D7)	PP9001(Connector)
			Main P.C.B.
7	Lens Unit	(Fig. D8)	FP9801(Flex)
			FP9802(Flex)
			1 Locking tab
			Lens Unit
8	Sub P.C.B.	(Fig. D9)	1 Screw (E)
			1 Locking tab
			PCB Spacer
			Sub P.C.B.
9	Battery Case	(Fig. D10)	Frame
			3 Locking tabs
			Battery Case

8.3.1. Removal of the Rear Case Unit

NOTE:

When servicing and reassembling, remove the card and battery from the unit.

- Card
- Battery
- Screw (A) × 4
- FP9001 (Flex)
- FP9002 (Flex)

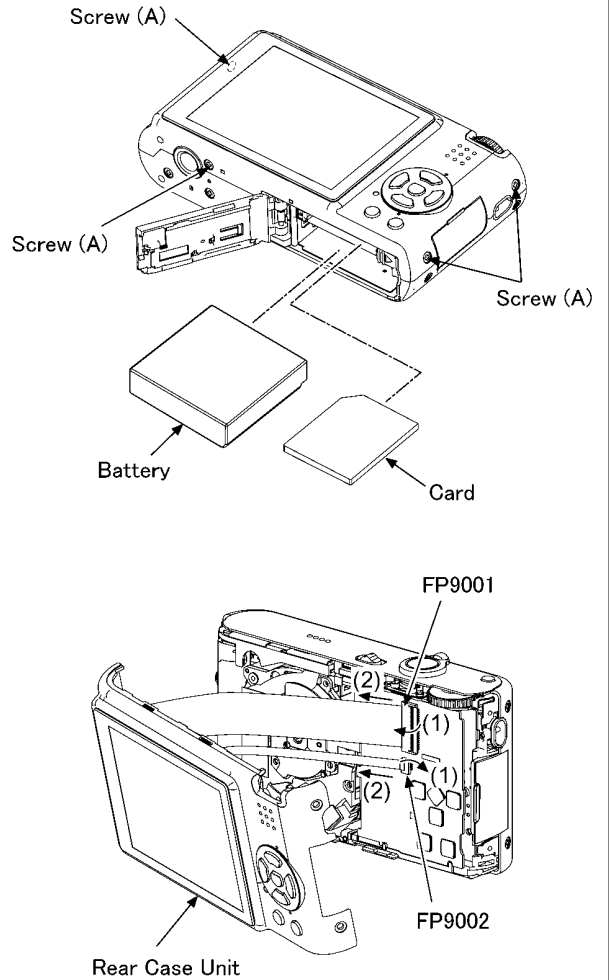

NOTE: (When Replacing)

When remove the flex, pull up the locking tab in the direction of arrow (1), and then remove the flex in the direction of arrow (2).

Screw (A)

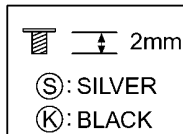

(Fig. D1)

8.3.2. Removal of the LCD Unit

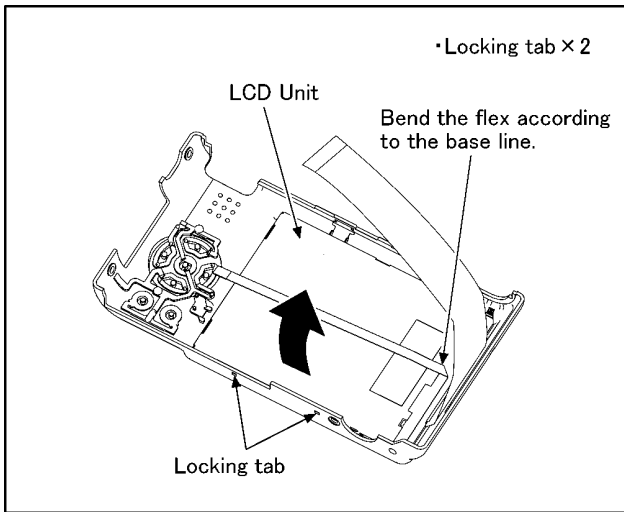

(Fig. D2)

8.3.3. Removal of the Front Case Unit

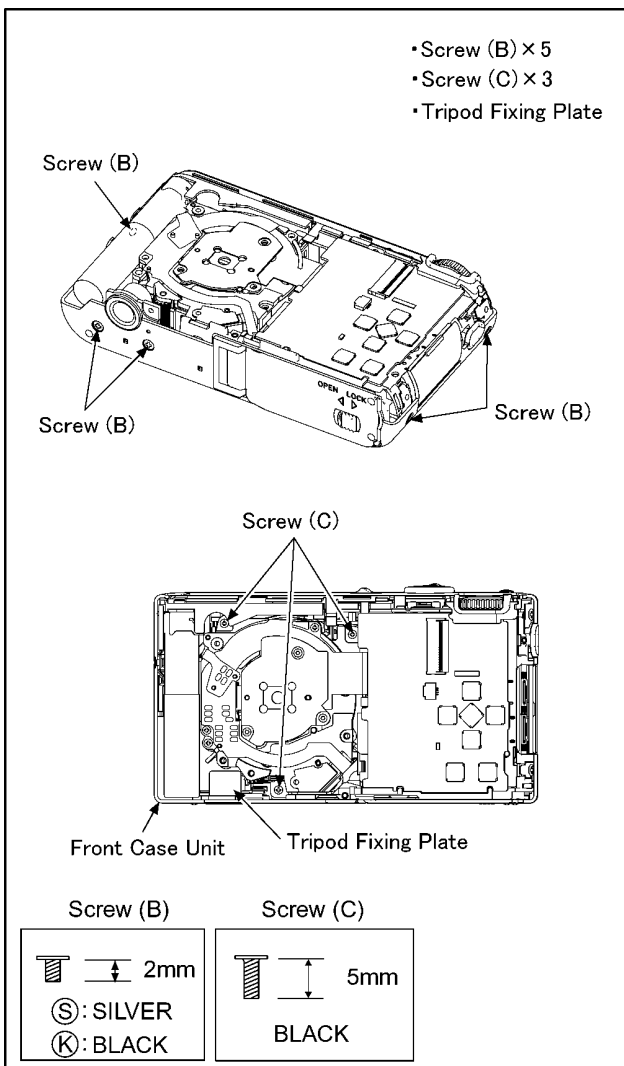

(Fig. D3)

8.3.4. Removal of the Top Operation Unit

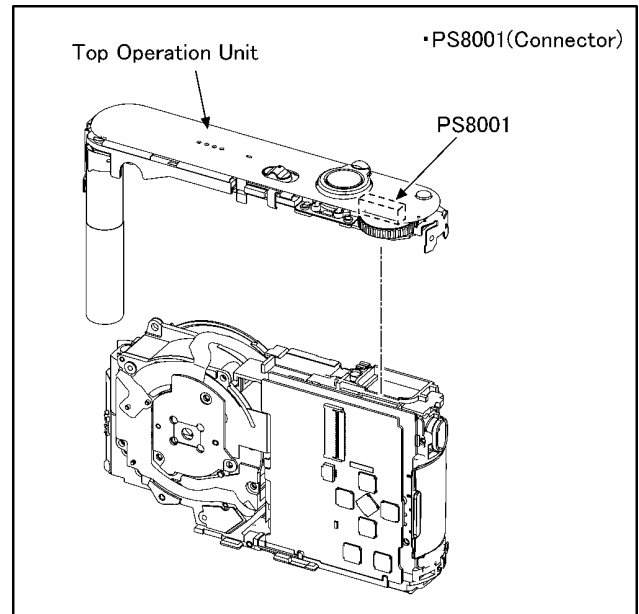

(Fig. D4)

8.3.5. Removal of the Flash Top P.C.B.

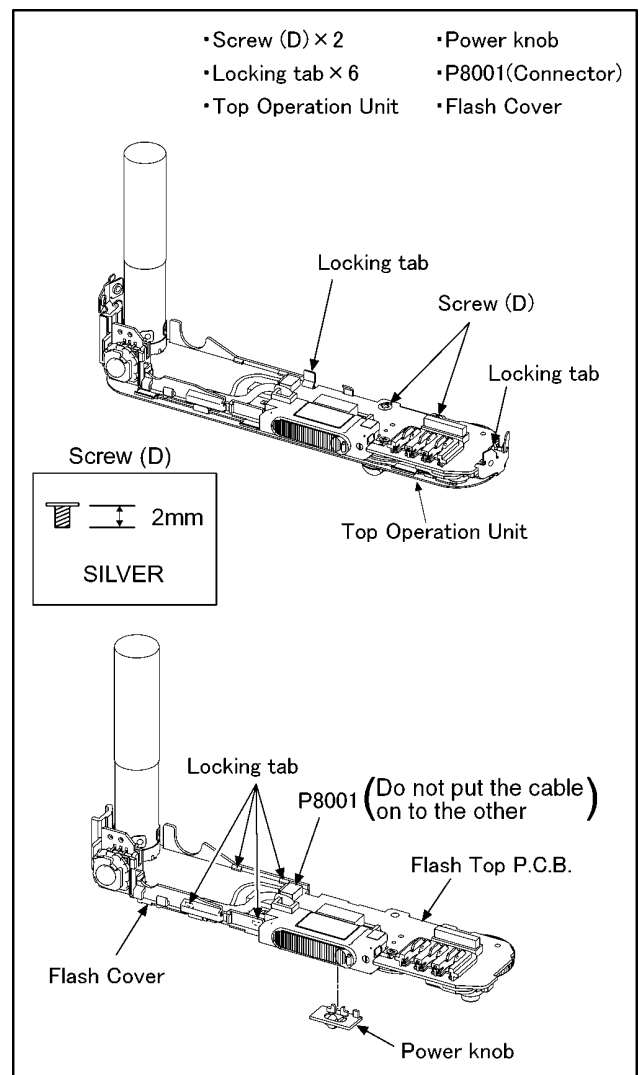

(Fig. D5)

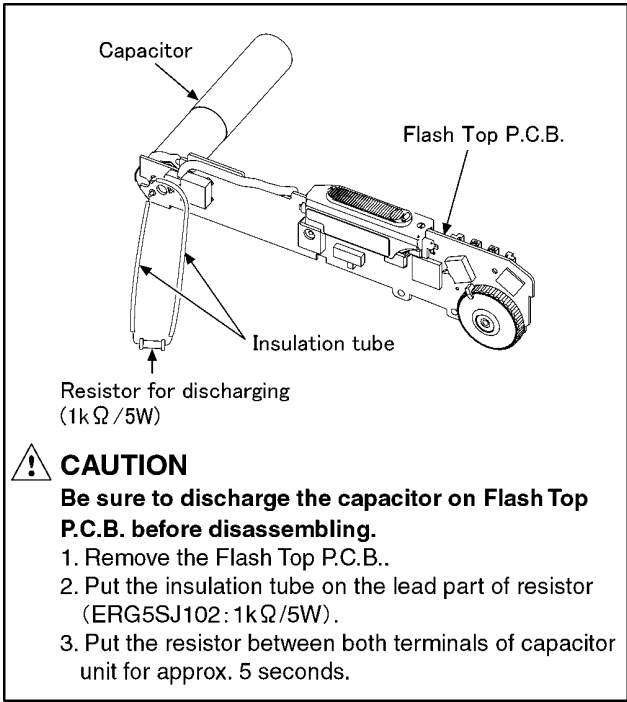

(Fig. D6)

8.3.6. Removal of the Main P.C.B.

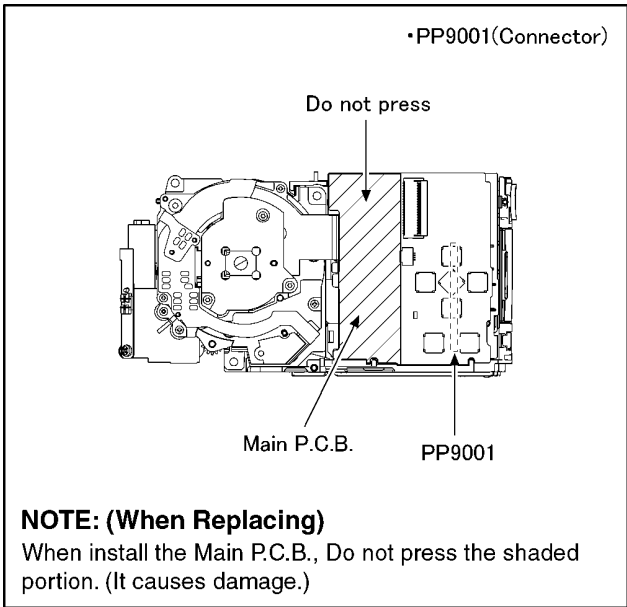

(Fig. D7)

8.3.7. Removal of the Lens Unit

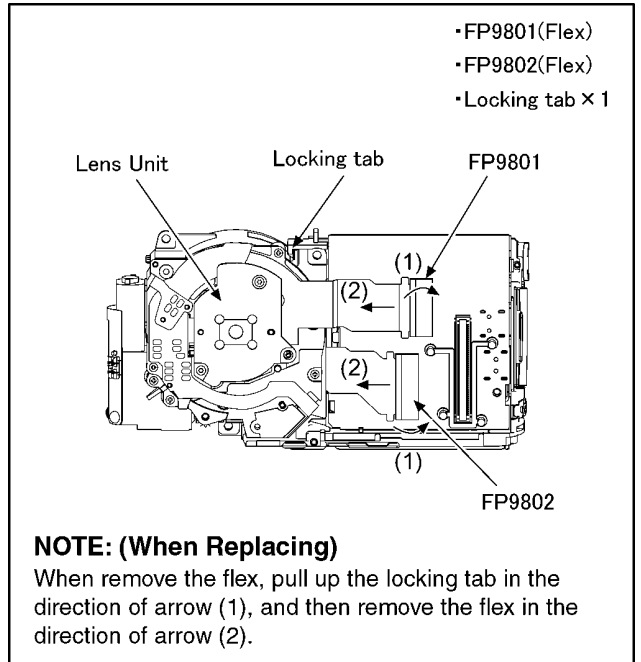

(Fig. D8)

8.3.8. Removal of the Sub P.C.B.

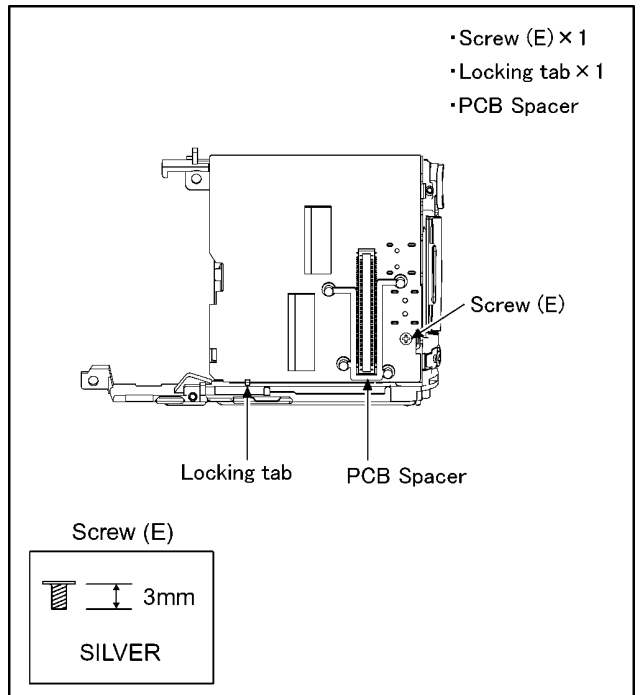

(Fig. D9)

8.3.9. Removal of the Battery Case

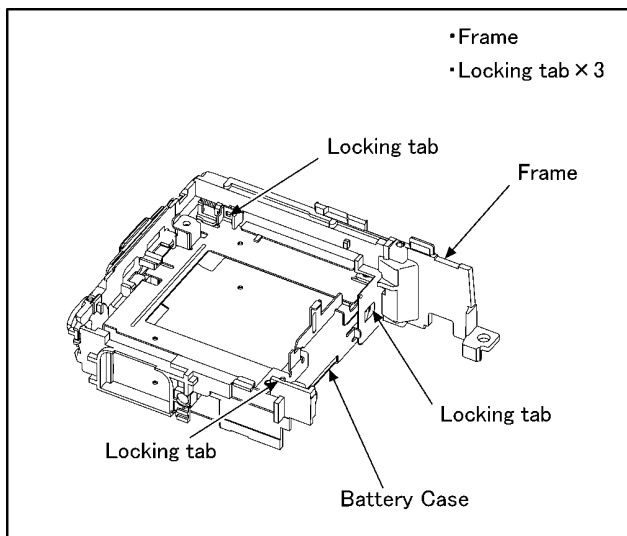

(Fig. D10)

NOTE: (When Assembling)

Be sure to confirm the following points when assembling.

- The Screw is tightened enough.
- Assembling conditions are fine. (No distortion, no illegal-space.)
- No dust and/or dirt on every Lens surfaces.
- LCD image is fine. (No dust and dirt on it, and no gradient images.)

8.4. Disassembly Procedure for the Lens

NOTE: When Disassembling and Assembling for the Lens

1. To minimize the possibility of the CCD being dirt, perform disassemble and/or assemble under the condition of the CCD is being mounted.
Disassembling procedures for the CCD unit, refer to item 8.6.
2. Take care that the dust and dirt are not entered into the lens.
In case of the dust is putted on the lens, blow off them by airbrush.
3. Do not touch the surface of lens.
4. Use lens cleaning KIT (BK)(VFK1900BK).
5. Apply the grease (VFK1829) to the point where is shown to "Grease apply" in the figure.
When the grease is applied, use a toothpick and apply thinly.

8.4.1. Zoom Motor Unit, Master Frange Unit, Drive/Direct Frame Unit and 1st Lens Frame/2nd Lens Frame Move Unit

1. Remove the cover to the indicated by arrow (A).
2. Unscrew the 2 screws (A).
3. Remove the zoom motor unit to the indicated by arrow.
4. Remove the lock (1 point).
5. Unscrew the 1 screw (B).

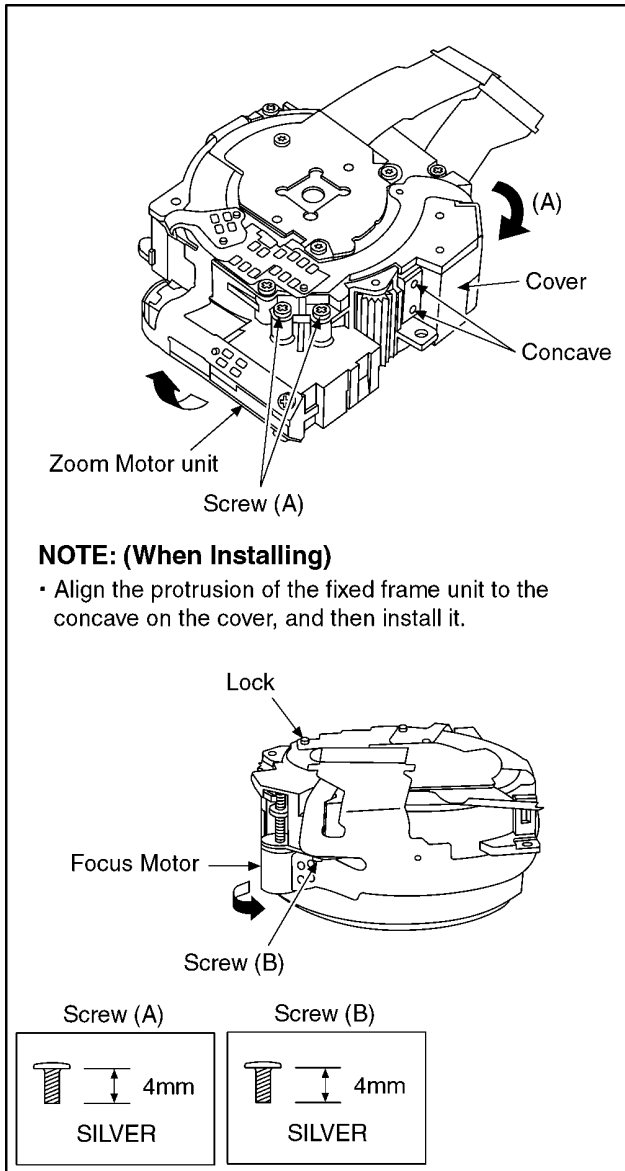

6. Push the focus motor to the indicated arrow (B).
7. Lift the flex to the indicated by arrow (C), and to see the convex part.

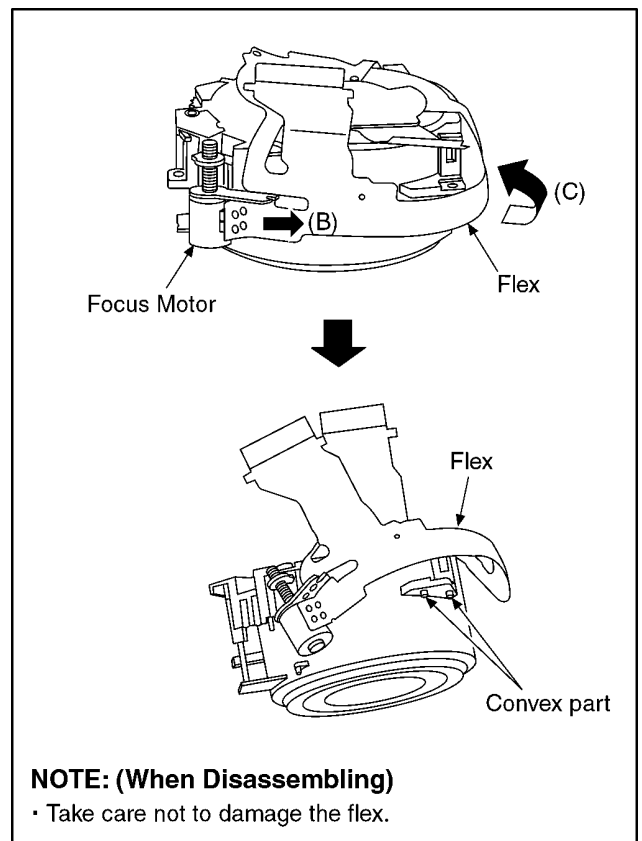

8. Temporarily tightened the focus motor with screw (B).
9. Unscrew the 3 screws (C).
10. Remove the master flange unit.

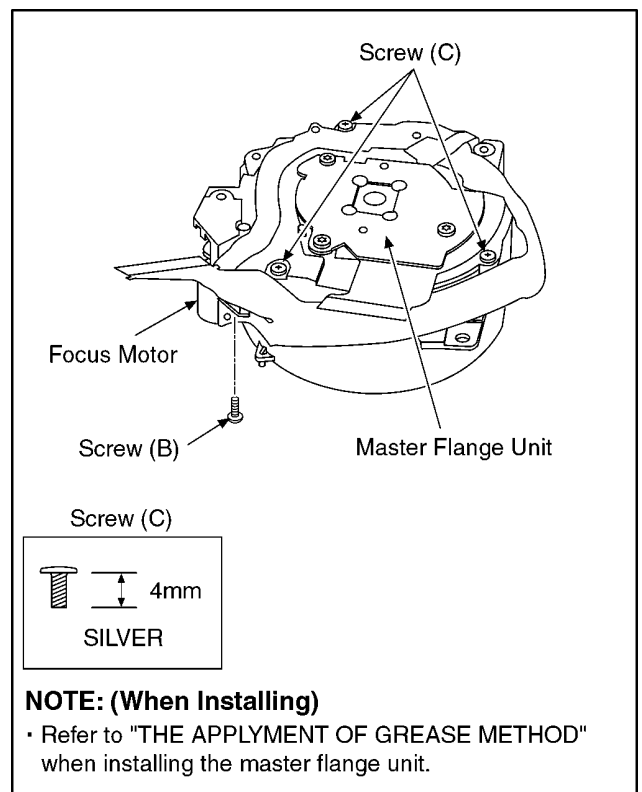

11. Turn the drive gear to the indicated by arrow fully.

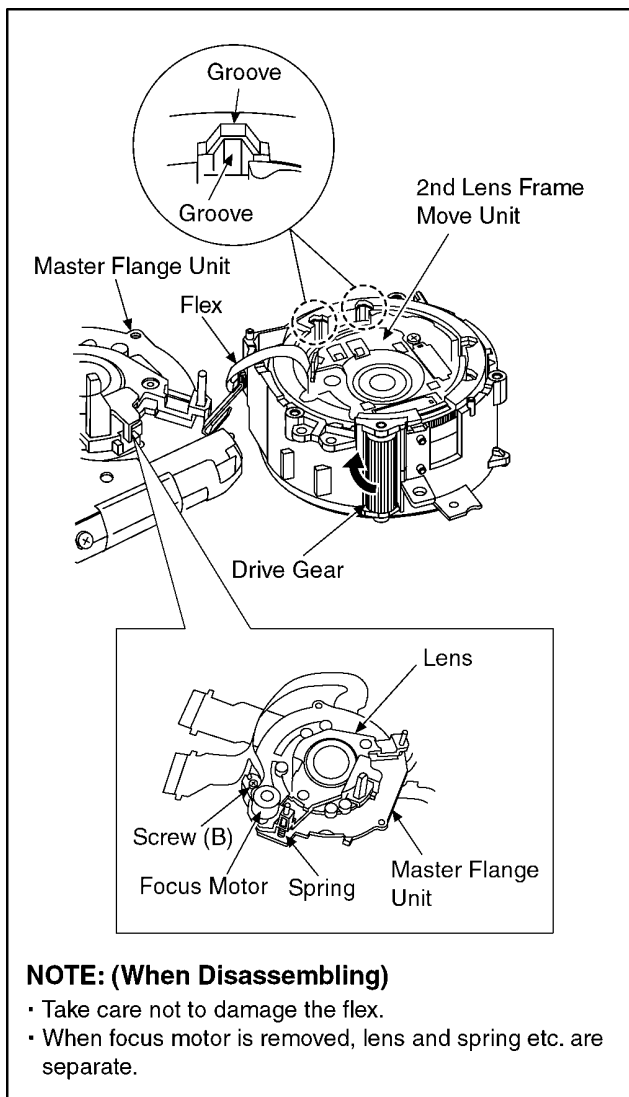

12. Push the drive unit to the indicated by arrow from lens side, and then remove the unit of drive/direct frame unit, 1st lens frame/2nd lens frame move unit from the fixed frame unit.

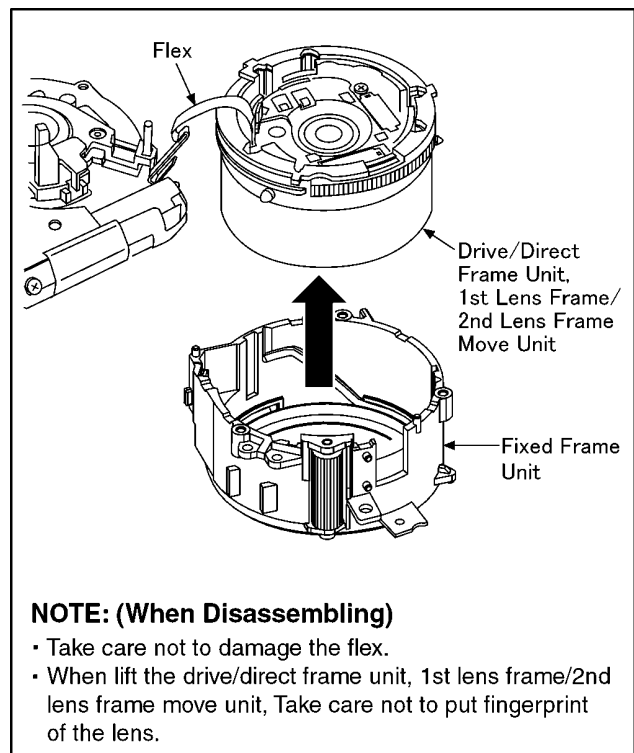

13. Push the 1st lens frame unit to the indicated by arrow from lens side, and then remove the unit of 1st lens frame/2nd lens frame move unit from the drive/direct frame unit.

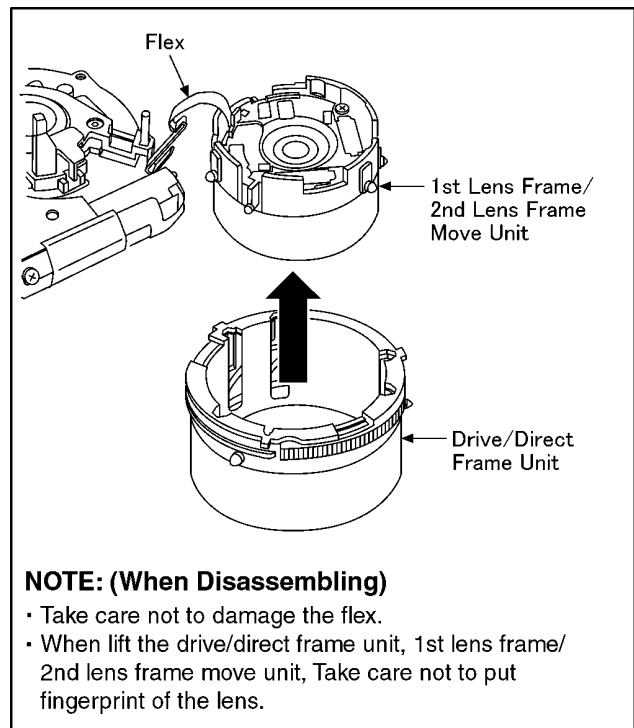

8.4.2. Removal of the Direct Frame

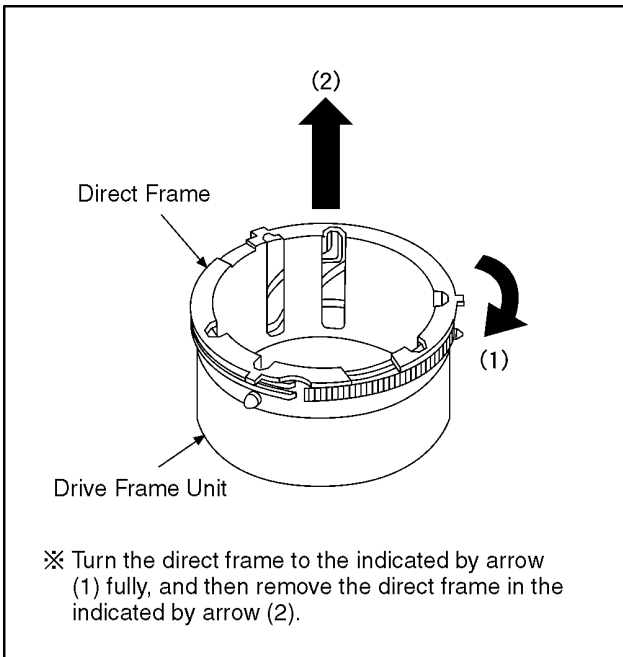

8.4.3. Removal of the 2nd Lens Frame Move Unit

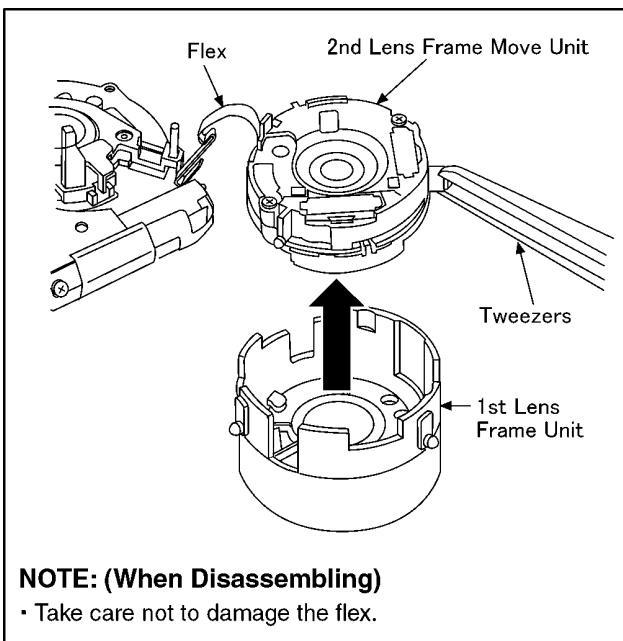

8.5. Assembly Procedure for the Lens

8.5.1. Phase alignment of the Direct Frame and Drive Frame Unit

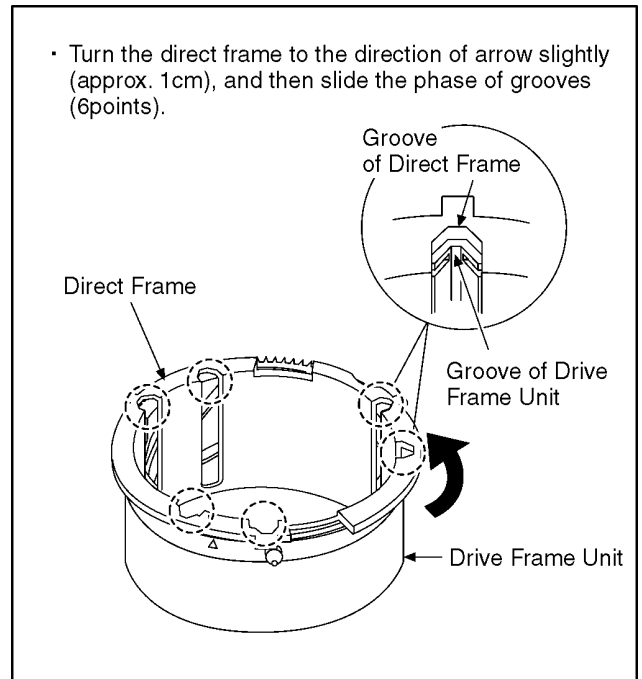
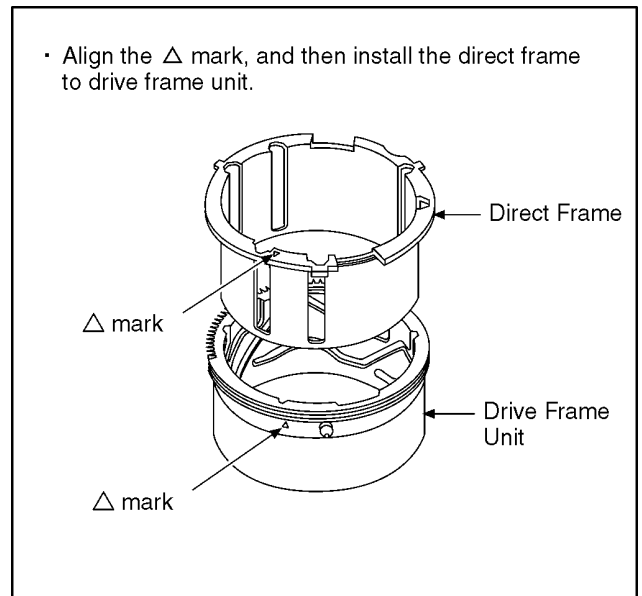

8.5.2. Phase alignment of the Drive/Direct Unit and Fixed Frame Unit

- Align the Δ mark, and then install the drive/direct unit to fixed frame unit.
- ※ With aligning the phase of 6 grooves of the drive/direct unit, confirm the gear of drive unit is engaged with the fixed frame unit firmly.

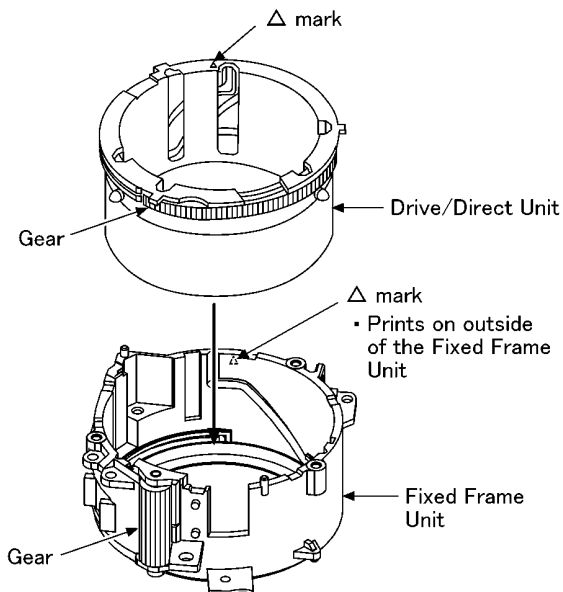

8.5.3. Assembly for the 1st Lens Frame Unit

- Insert the 1st lens frame unit to the fixed frame unit at the position of the figure below.

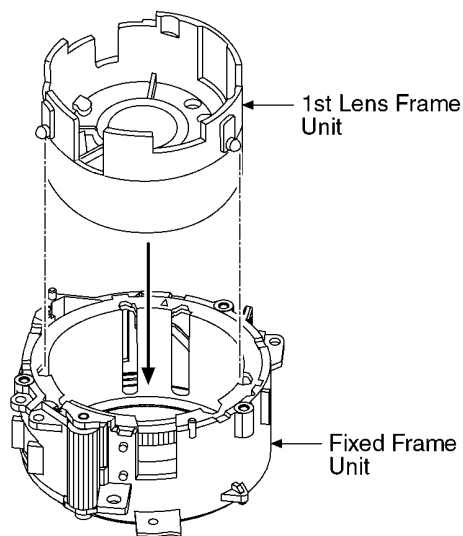

FRONT VIEW

- Install the 1st lens frame unit so that the "LEICA" character may become the position of the figure below.

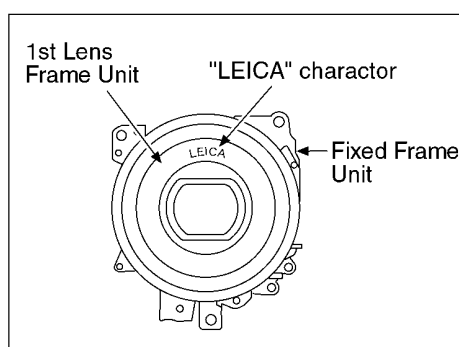

8.5.4. Assembly for the 2nd Lens Frame Move Unit

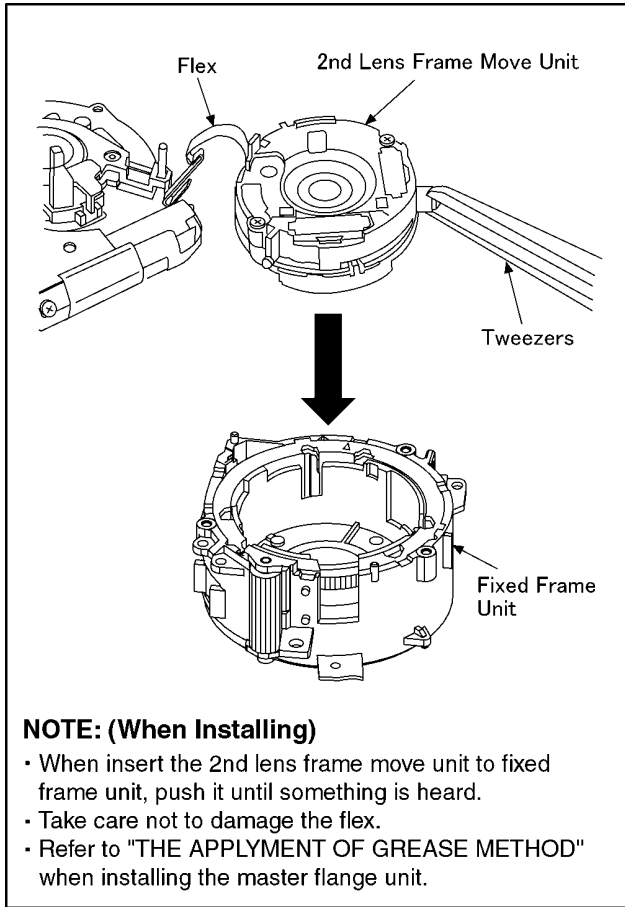

8.5.5. Assembly for the Zoom Motor Unit and Master Frange Unit

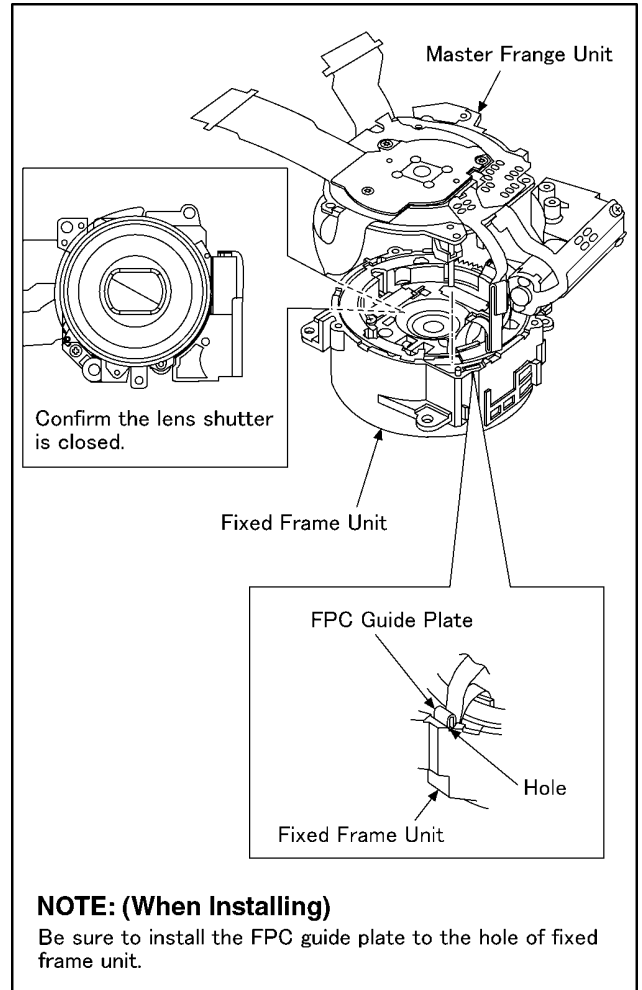

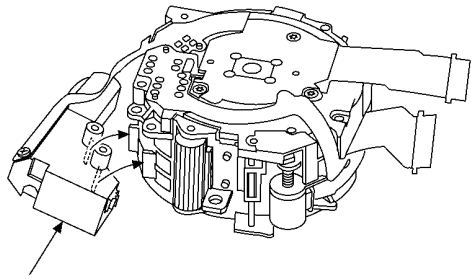

Zoom MotorUnit

NOTE: (When Installing)

- Align the convex of fixed frame unit to the reentrant of zoom motor unit, and then install.

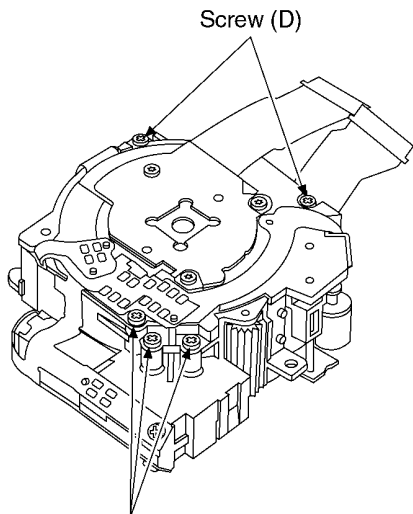

Screw (D)

- Unscrew the screw (E), and then remove the focus motor.

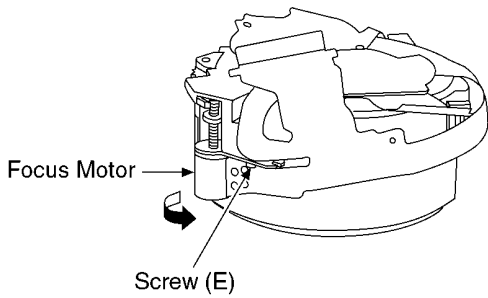

Screw (D)

Screw (E)

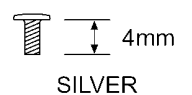
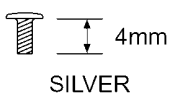

- Move the flex to under the convex of the fixed frame unit.

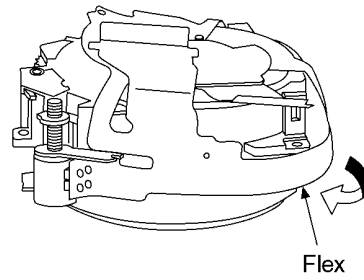

Flex

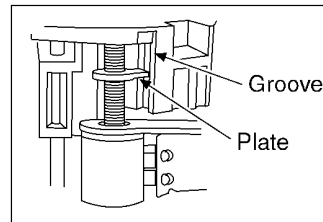

- Align the plate to the groove.

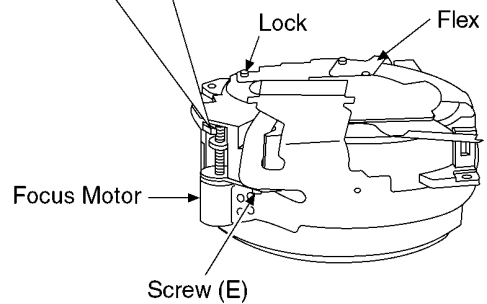

- Tighten the Screw (E), and install the focus motor again.
- Fix the flex to the lock.

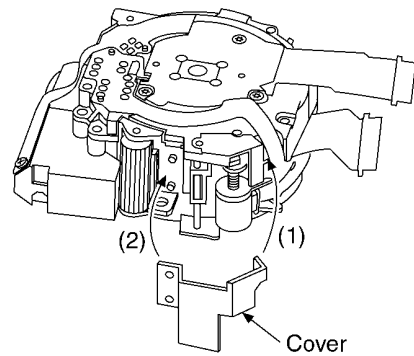

- Install the cover in order of (1) to (2).

8.6. Removal of the CCD Unit

To prevent the CCD unit from catching the dust and dirt, do not remove the CCD unit except for replacing.

- Torx driver (T3): RFKZ0334

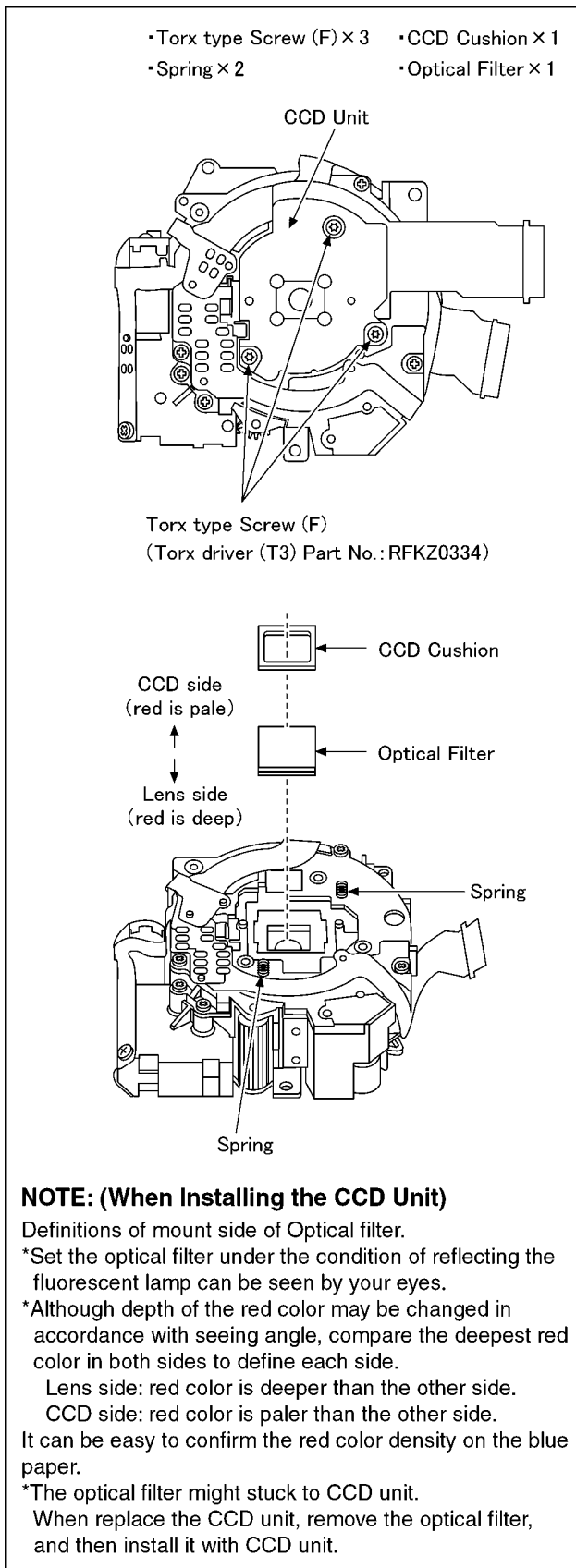

8.7. The Applymt of Grease Method

The grease apply point of lens unit are as follows.

Apply grease additionally in the specified position if necessary.

- Lead screw
 - Grease: VFK1850 (Furoyl type)
 - Amount of apply: 2 - 4 mg
- Guide pole
 - Grease: VFK1829
 - Amount of apply: 2 - 4 mg

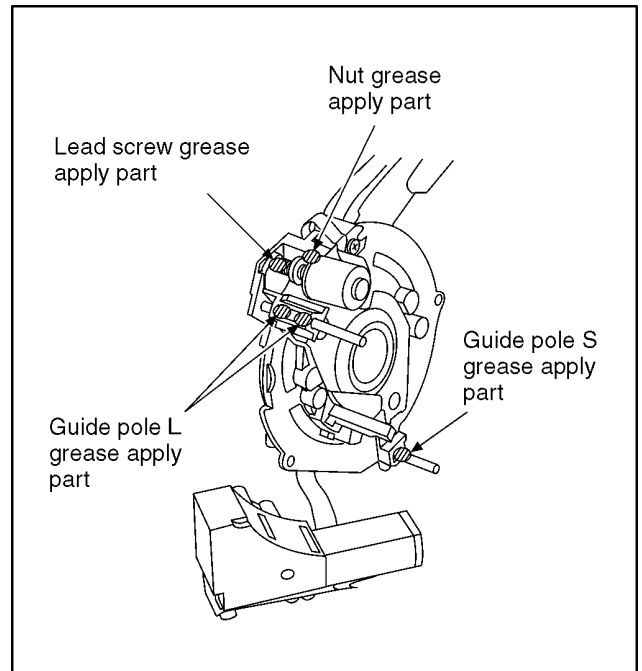

9 Measurements and Adjustments

9.1. Matrix Chart for Replaced Part and Necessary Adjustment

The relation between Replaced part and Necessary Adjustment is shown in the following table.

When concerned part is replaced, be sure to achieve the necessary adjustment(s).

As for Adjustment condition/procedure, consult the "Adjustment Manual" which is available in Adjustment software.

The Adjustment software is available at "TSN Website", therefore, access to "TSN Website" at "Support Information from NWBG/VDBG-PAVC".

NOTE:

After adjustments have been terminated, make sure to achieve "INITIAL SETTINGS".

Adjustment Item		Replaced Part				
		Main P.C.B.	VENUS (IC6001)	Flash-ROM (IC6002)	Lens Part (Excluding CCD)	CCD Unit
Camera Section	OIS hall element adjustment (OIS)	○	○	○	○	
	Back focus adjustment (BF)	○	○	○	○	
	Shutter adjustment (SHT)	○	○	○	○	○
	ISO sensitivity adjustment (ISO)	○	○	○	○	○
	AWB adjustment High brightness coloration inspection (WBL)	○	○	○	○	○
	CCD white scratch compensation (WKI)	○	○	○		○

NOTE:

*There is no LCD adjustment in this model.

*There is no CCD Black scratch compensation adjustment (BKI) in this model.

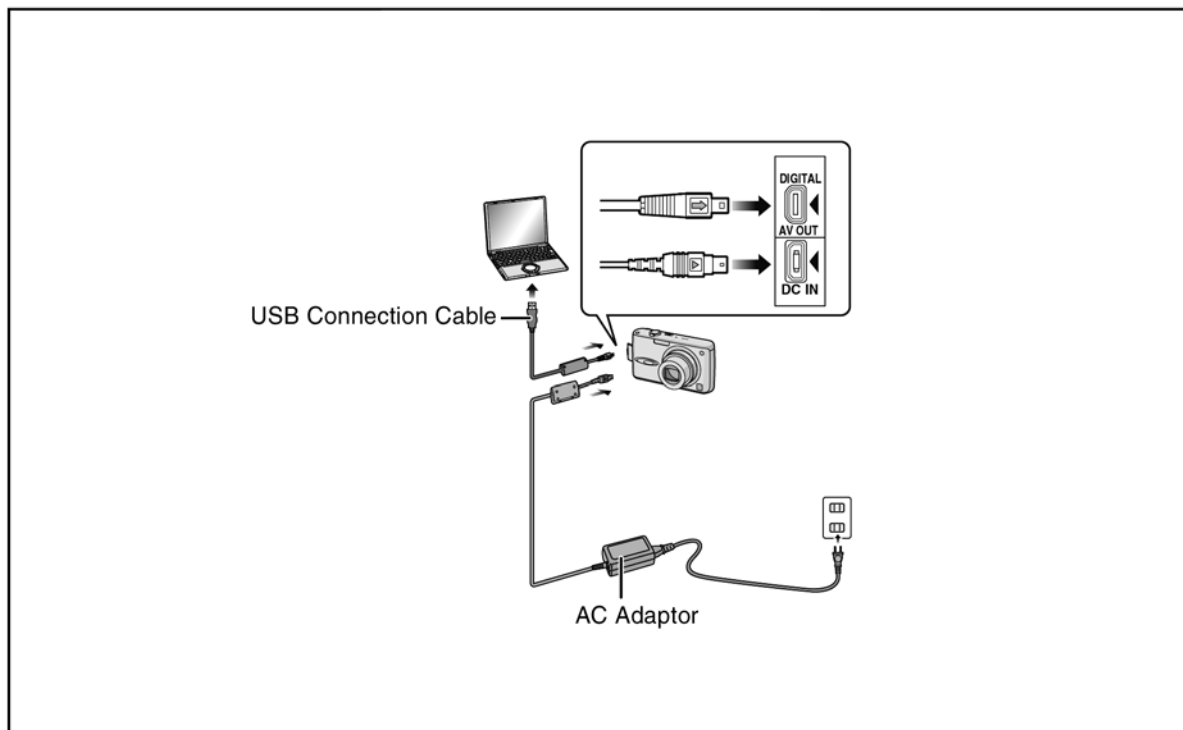

10 Maintenance

10.1. Cleaning Lens and LCD Panel

Do not touch the surface of lens and LCD Panel with your hand.

When cleaning the lens, use air-Blower to blow off the dust.

When cleaning the LCD Panel, dampen the lens cleaning paper with lens cleaner, and the gently wipe the their surface.

Note:

The Lens Cleaning KIT ; VFK1900BK (Only supplied as 10 set/Box) is available as Service Aid.

Service Manual

Diagrams and Replacement Parts List

Digital Camera

- | | |
|-----------|------------|
| DMC-FX3PP | DMC-FX3EGM |
| DMC-FX3PL | DMC-FX3GC |
| DMC-FX3EB | DMC-FX3GD |
| DMC-FX3EE | DMC-FX3GK |
| DMC-FX3EF | DMC-FX3GN |
| DMC-FX3EG | DMC-FX3GT |

Vol. 1
 Colour
 (S).....Silver Type
 (K).....Black Type

S1. About Indication of The Schematic Diagram

S1.1. Important Safety Notice

COMPONENTS IDENTIFIED WITH THE MARK \triangle HAVE THE SPECIAL CHARACTERISTICS FOR SAFETY. WHEN REPLACING ANY OF THESE COMPONENTS USE ONLY THE SAME TYPE.

1. Although reference number of the parts is indicated on the P.C.B. drawing and/or schematic diagrams, it is NOT mounted on the P.C.B. when it is displayed with "\$" mark.
2. It is only the "Test Round" and no terminal (Pin) is available on the P.C.B. when the TP (Test Point) indicated as "●" mark.
3. The voltage being indicated on the schematic diagram is measured in "Standard-Playback" mode when there is no specify mode is mentioned.
4. Although the voltage and waveform available on here is measured with standard frame, it may be differ from actual measurement due to modification of circuit and so on.
5. The voltage being indicated here may be include observational-error (deviation) due to internal-resistance and/or reactance of equipment. Therefore, handle the value indicated on here as reference.
6. Use the parts number indicated on the Replacement Parts List .
7. Indication on Schematic diagrams:

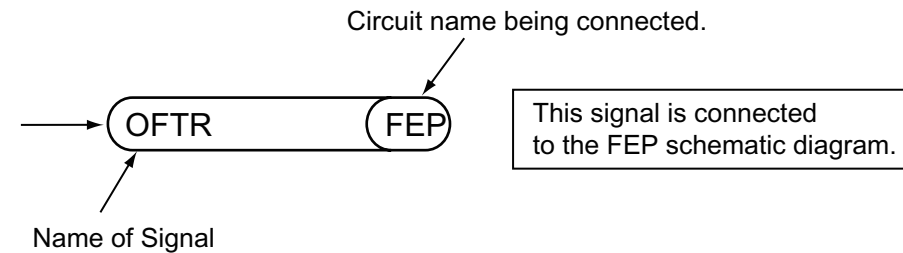

Table of contents

S1. About Indication of The Schematic Diagram.....	S-1	S6. Replacement Parts List.....	S-11
S1.1. Important Safety Notice.....	S-1		
S2. Voltage Chart	S-2	S7. Exploded View	S-18
S2.1. Flash Top P.C.B.....	S-2	S7.1. Frame and Casing Section.....	S-18
S3. Block Diagram.....	S-3	S7.2. Packing Parts and Accessories Section (1)	S-19
S3.1. Overall Block Diagram	S-3	S7.3. Packing Parts and Accessories Section (2)	S-20
S4. Schematic Diagram.....	S-4		
S4.1. Interconnection Diagram	S-4		
S4.2. Flash Top Schematic Diagram	S-5		
S4.3. AF Assist LED Schematic Diagram	S-6		
S4.4. CCD Flex Schematic Diagram	S-6		
S4.5. Lens Flex Schematic Diagram	S-7		
S5. Print Circuit Board	S-8		
S5.1. Flash Top P.C.B.....	S-8		
S5.2. AF Assist LED P.C.B.	S-9		
S5.3. CCD Flex P.C.B.....	S-9		
S5.4. Lens Flex P.C.B.....	S-10		

S2. Voltage Chart

Note) Indicated voltage values are the standard values for the unit measured by the DC electronic circuit tester (high-impedance) with the chassis taken as standard.
Therefore, there may exist some errors in the voltage values, depending on the internal impedance of the DC circuit tester.

S2.1. Flash Top P.C.B.

REF No.	PIN No.	POWER ON
IC8001	1	0
IC8001	2	0
IC8001	3	4.9
IC8001	4	0
IC8001	5	0
Q8009	1	4
Q8009	2	4
Q8009	3	0
Q8009	4	0
Q8009	5	4
Q8009	6	4

S3. Block Diagram

S3.1. Overall Block Diagram

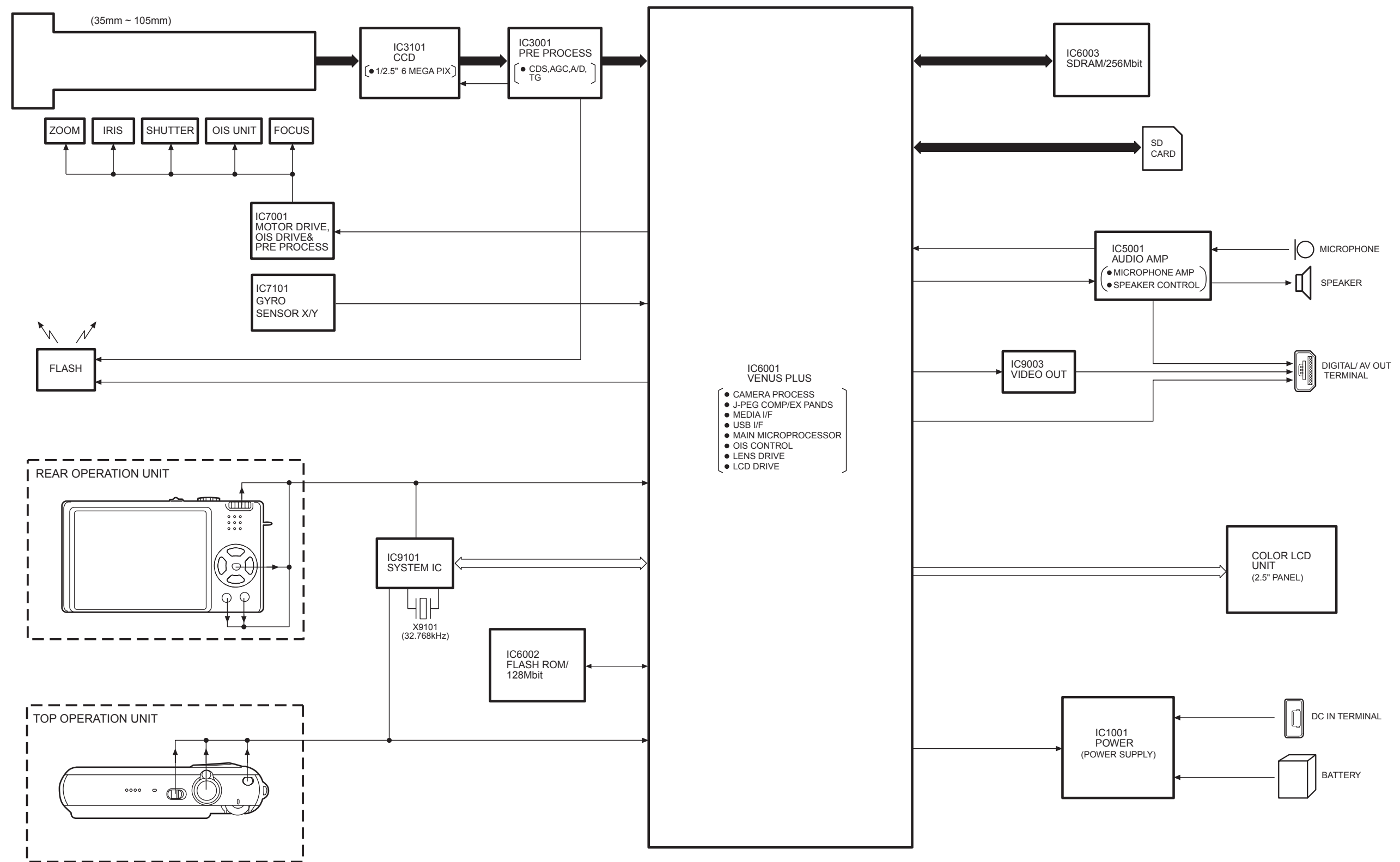

S4. Schematic Diagram

S4.1. Interconnection Diagram

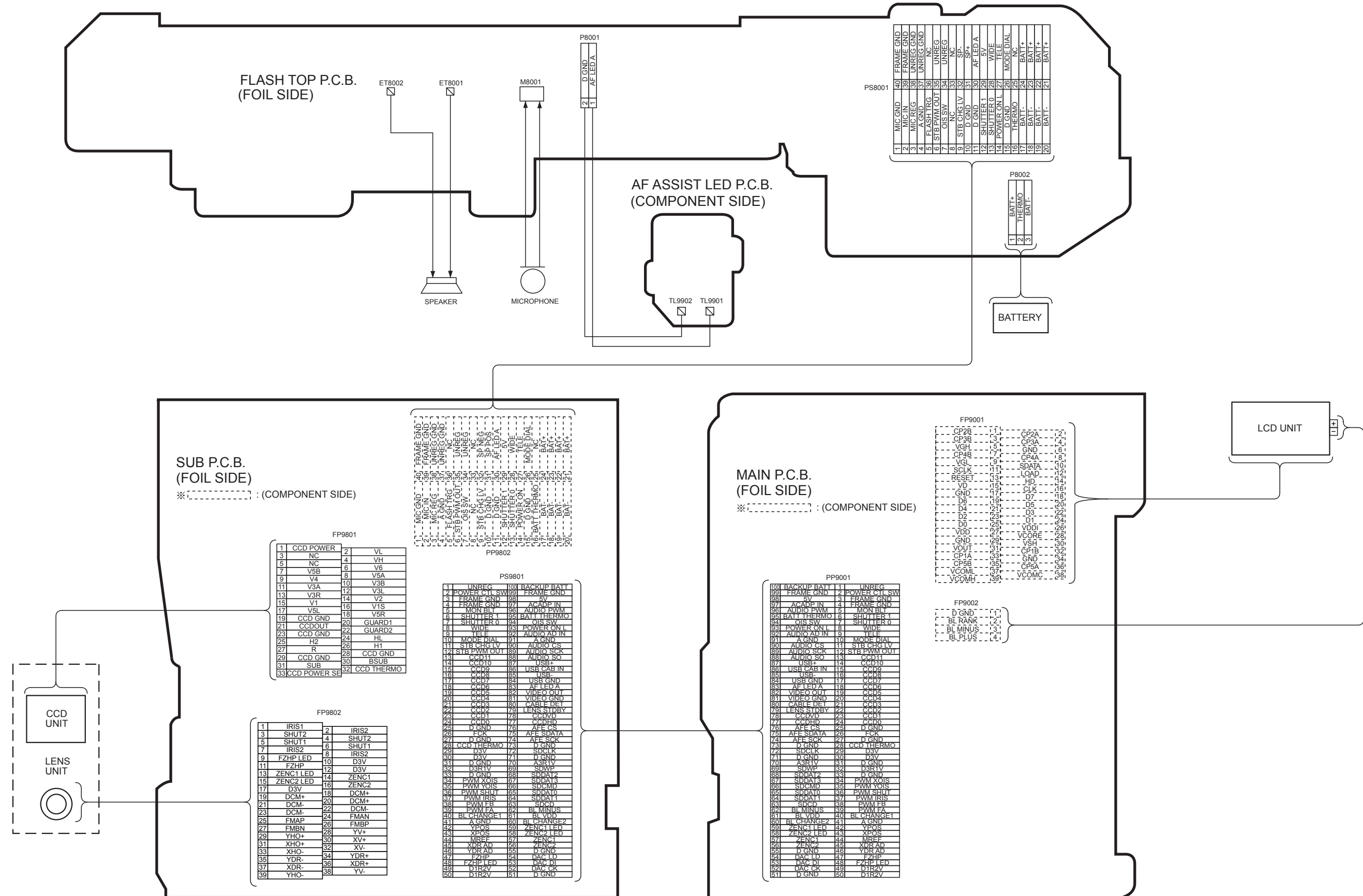

S4.2. Flash Top Schematic Diagram

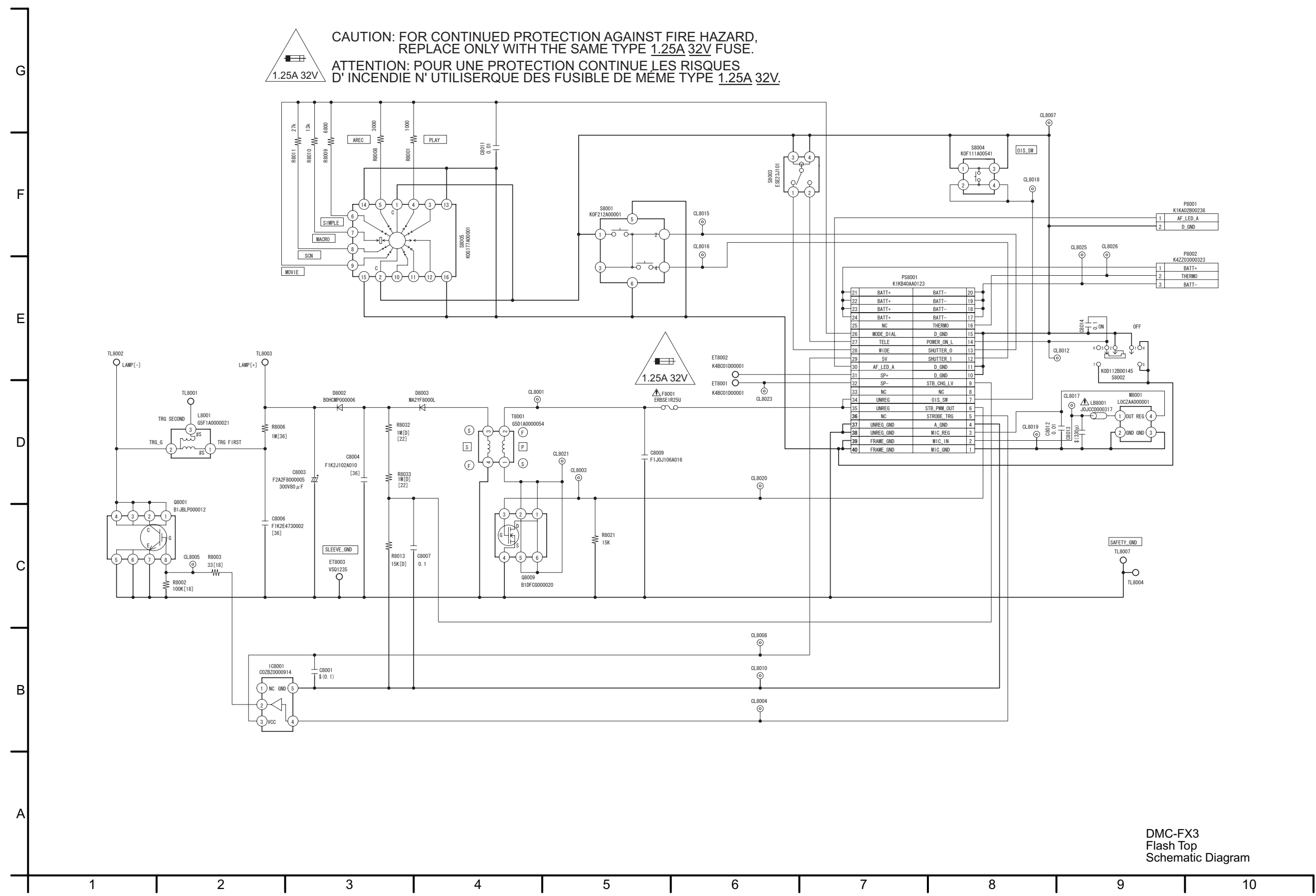

DMC-FX3
Flash Top
Schematic Diagram

S4.3. AF Assist LED Schematic Diagram / S4.4. CCD Flex Schematic Diagram

G
F
E
D
C
B
A

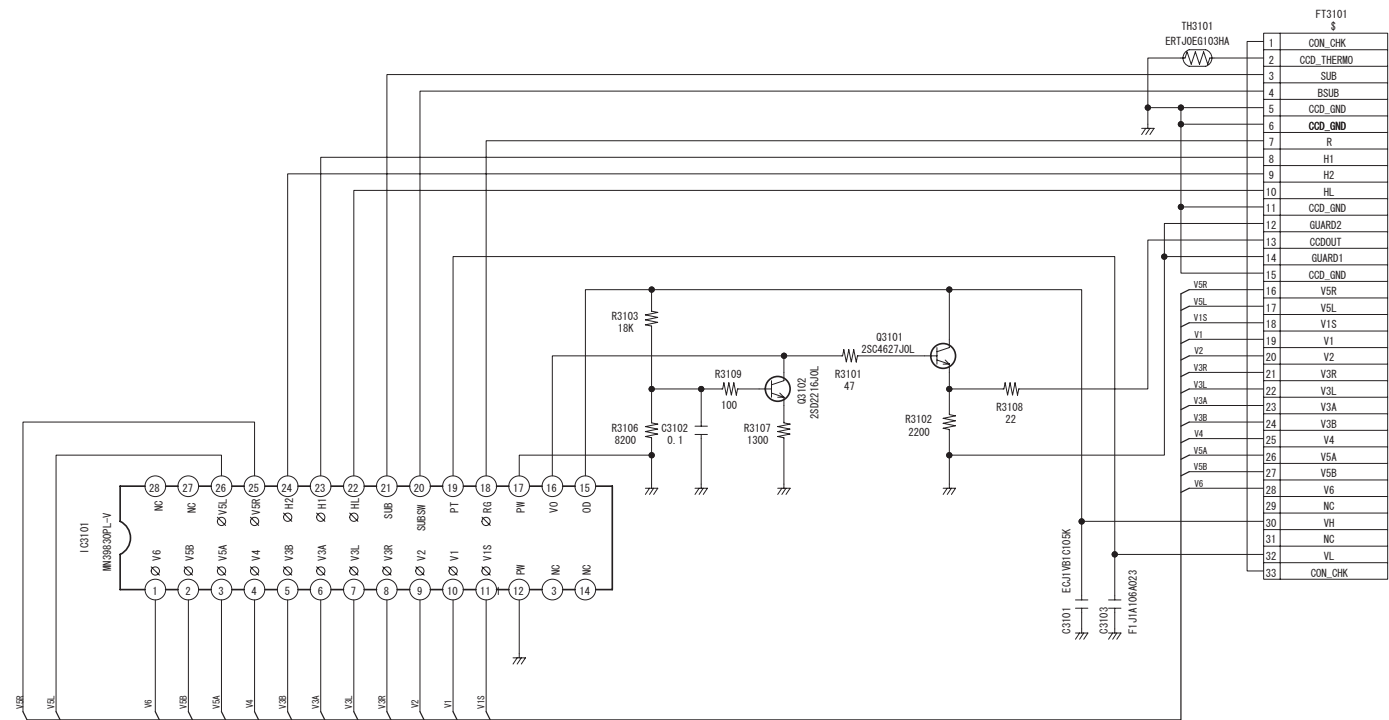
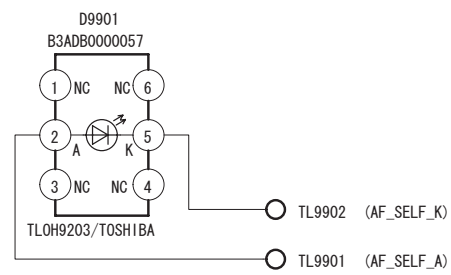

DMC-FX3
AF Assist LED
Schematic Diagram

DMC-FX3
CCD Flex
Schematic Diagram

S4.5. Lens Flex Schematic Diagram

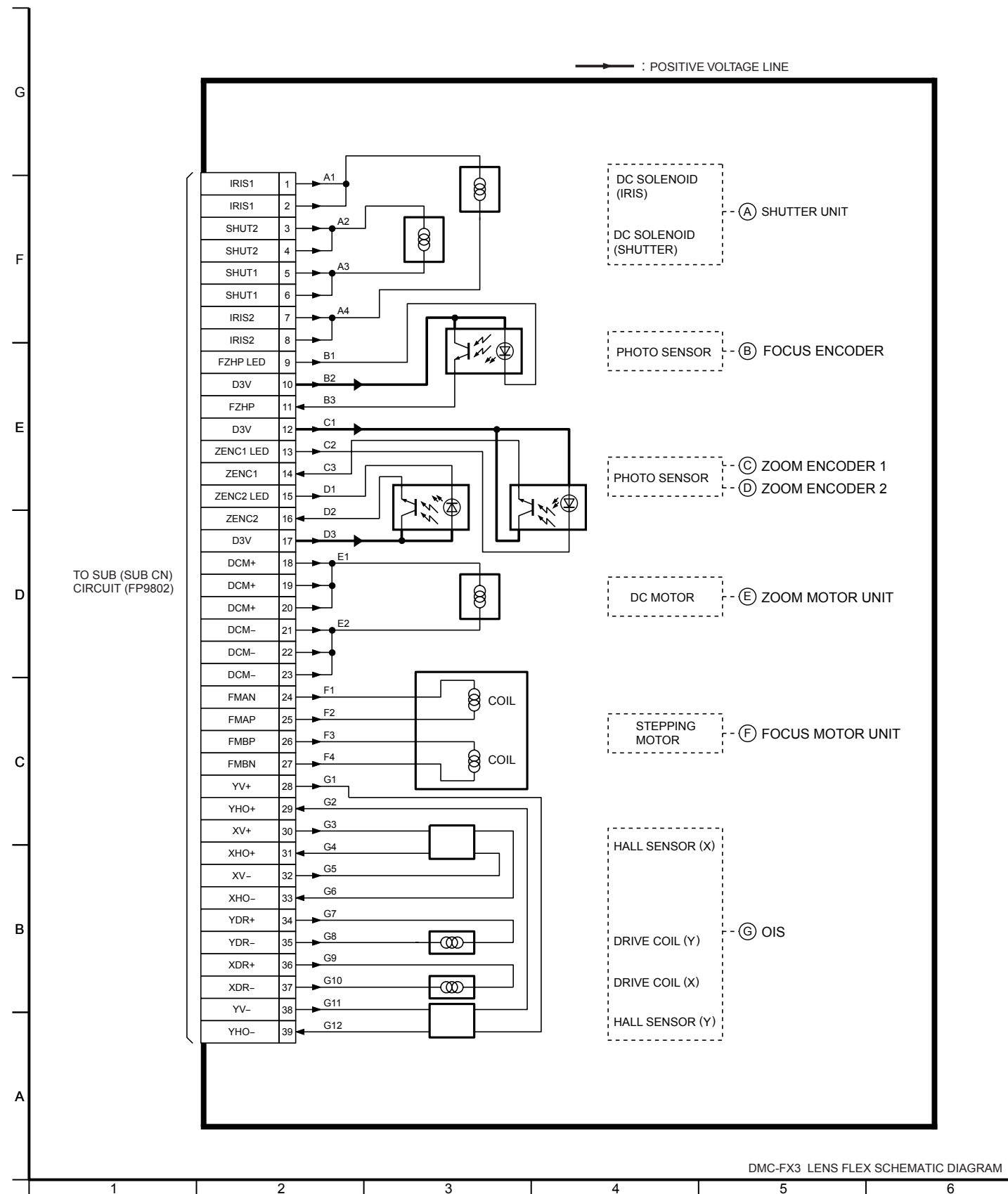

S5. Print Circuit Board

S5.1. Flash Top P.C.B.



DMC-FX3
Flash Top P.C.B.

S5.2. AF Assist LED P.C.B. / S5.3. CCD Flex P.C.B.

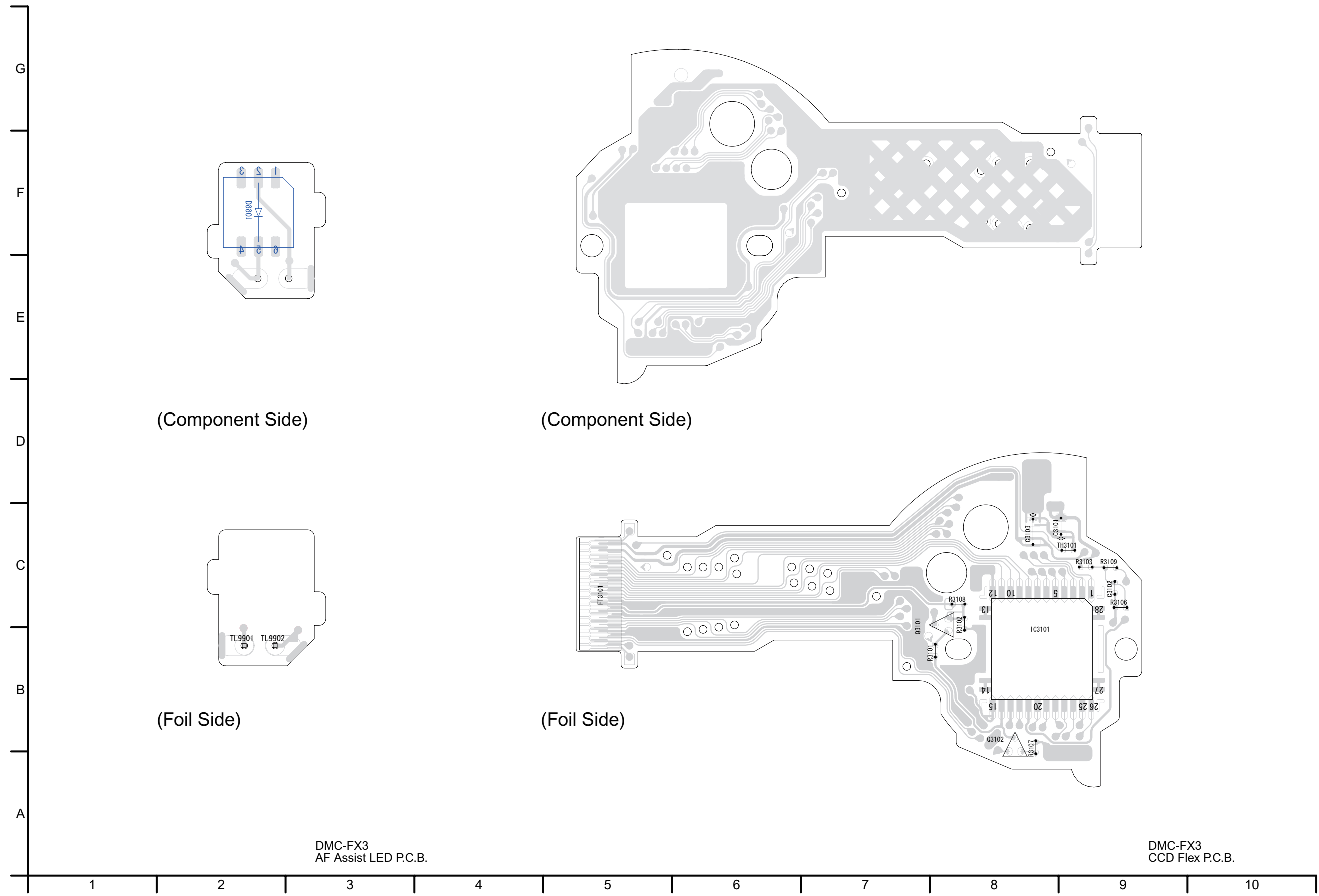

DMC-FX3
AF Assist LED P.C.B.

DMC-FX3
CCD Flex P.C.B.

S5.4. Lens Flex P.C.B.

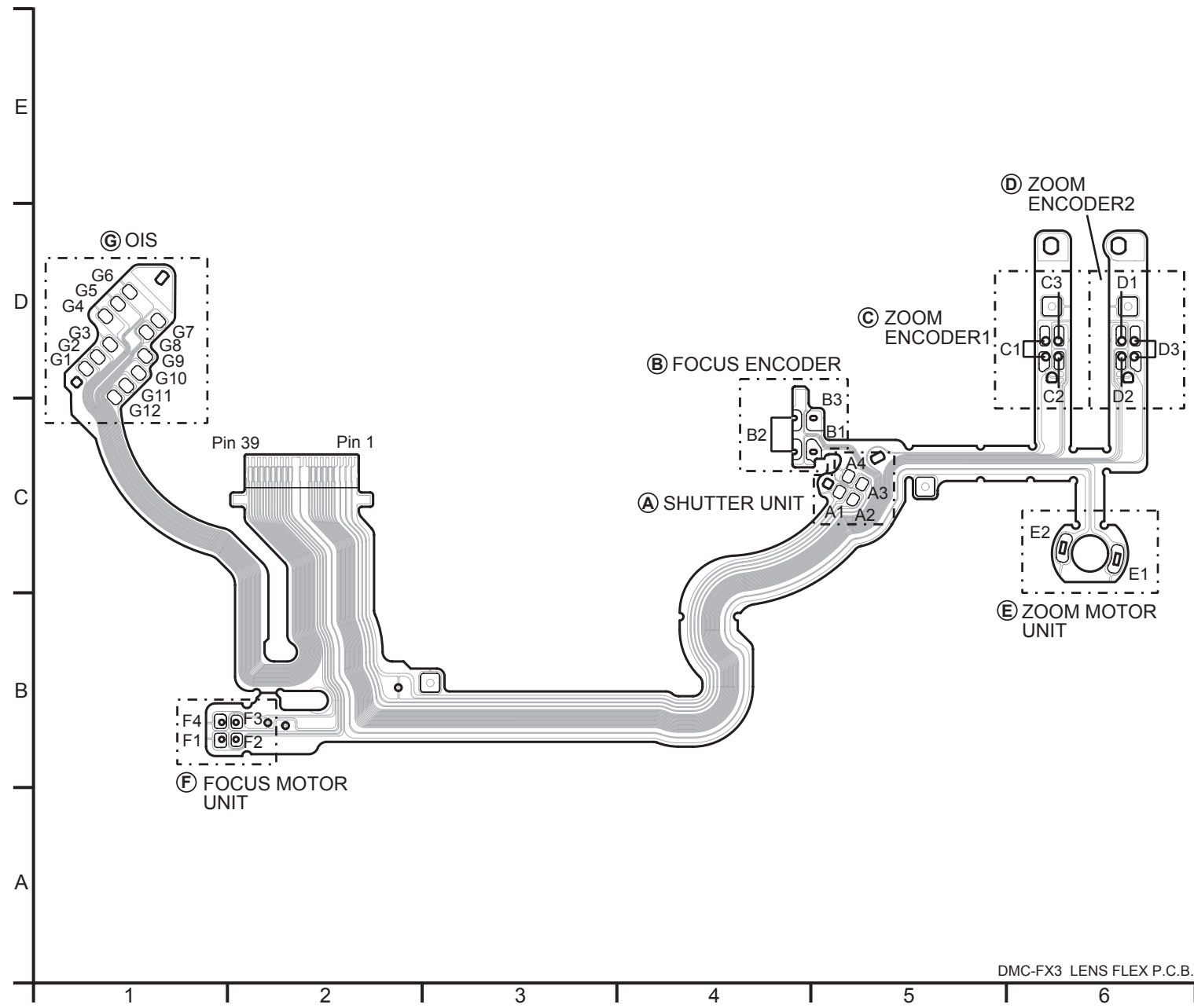

S6. Replacement Parts List

- Note: 1.* Be sure to make your orders of replacement parts according to this list.
2. IMPORTANT SAFETY NOTICE
Components identified with the mark \triangle have the special characteristics for safety.
When replacing any of these components, use only the same type.
3. Unless otherwise specified,
All resistors are in OHMS, K=1,000 OHMS. All capacitors are in MICRO-FARADS (uf), P=uuF.
4. The marking (RTL) indicates the retention time is limited for this item. After the discontinuation of this assembly in production, it will no longer be available.

E.S.D. standards for Electrostatically Sensitive Devices, refer to “PREVENTION OF ELECTROSTATIC DISCHARGE (ESD) TO ELECTROSTATICALLY SENSITIVE (ES) DEVICES” section.

Definition of Parts supplier:

1. Parts marked with [MBI] in the remarks column are supplied from “Matsushita Battery Industrial Co., Ltd.”

DMC-FX3EGM-S/K,EF-S/K,EB-S/K,PP-S/K,EG-S/K,GC-S/K,PL-S/K,EE-S/K,GT-S/K,GK-S/K,GN-S/K,GD-S/K

Ref.No.	Part No.	Part Name & Description	Pcs	Remarks	Ref.No.	Part No.	Part Name & Description	Pcs	Remarks
D8002	B0HCMP000006	DIODE	1	E.S.D.					
D8003	MA2YF8000L	DIODE	1	E.S.D.					
ET8001	K4BC01D00001	EARTH TERMINAL	1						
ET8002	K4BC01D00001	EARTH TERMINAL	1						
△ F8001	ERBSE1R25U	FUSE 32V 1.25A	1						
IC8001	C0ZBZ0000914	IC	1	E.S.D.					
L8001	G5F1A0000021	TRIGGER COIL	1						
△ LB8001	J0JCC0000317	FILTER	1						
M8001	LOCZAA000001	MICROPHONE UNITS	1						
P8001	K1KA02B00236	CONNECTOR 2P	1						
P8002	K4ZZ03000323	CONNECTOR 3P	1						
PS8001	K1KB40AA0123	CONNECTOR 40P	1						
Q8001	B1JBLP000012	TRANSISTOR	1	E.S.D.					
Q8009	B1DFCG000020	TRANSISTOR	1	E.S.D.					
R8001	ERJ2GEJ102X	M.RESISTOR CH 1/16W 1K	1	ERJ2RMJ102X					
R8002	ERJ3GEYJ104	M.RESISTOR CH 1/10W 100K	1						
R8003	ERJ3GEYJ330	M.RESISTOR CH 1/10W 33	1						
R8006	ERJ8GEYJ105V	M.RESISTOR CH 1/8W 1M	1						
R8008	ERJ2GEJ302	M.RESISTOR CH 1/16W 3K	1						
R8009	ERJ2RHD682X	M.RESISTOR CH 1/16W 6.8K	1						
R8010	ERJ2GEJ133	M.RESISTOR CH 1/16W 13K	1						
R8011	ERJ2GED273X	M.RESISTOR CH 1/16W 27K	1	ERJ2RHD273X					
R8013	ERJ2RHD153X	M.RESISTOR CH 1/16W 15K	1						
R8021	ERJ2GEJ153	M.RESISTOR CH 1/16W 15K	1						
R8032	ERJ6RED105	M.RESISTOR CH 1/16W 1M	1						
R8033	ERJ6RED105	M.RESISTOR CH 1/16W 1M	1						
S8001	K0F212A00001	SWITCH	1						
S8002	K0D112B00145	SWITCH	1						
S8003	ESE23J101	SWITCH	1						
S8004	K0F111A00541	SWITCH	1						
S8005	K0G177A00001	SWITCH	1						
T8001	G5D1A0000054	TRANSFORMER	1						
##	VEP59029A	AF ASSIST LED P.C.B.		(RTL) E.S.D.					
D9901	B3ADB0000057	DIODE	1	E.S.D.					
##	VEK0K30	CCD UNIT		E.S.D.					
C3101	ECJ1VB1C105K	C.CAPACITOR CH 16V 1U	1						
C3102	ECJ0EB1A104K	C.CAPACITOR CH 10V 0.1U	1						
C3103	F1J1A106A023	C.CAPACITOR CH 10V 10U	1						
Q3101	2SC4627JCL	TRANSISTOR	1	E.S.D.					
Q3102	2SD2216J0L	TRANSISTOR	1	E.S.D.					
R3101	ERJ2GEJ470	M.RESISTOR CH 1/16W 47	1						
R3102	ERJ2GEJ222	M.RESISTOR CH 1/16W 2.2K	1						
R3103	ERJ2GEJ183	M.RESISTOR CH 1/16W 18K	1						
R3106	ERJ2GEJ822	M.RESISTOR CH 1/16W 8.2K	1						
R3107	ERJ2GEJ132	M.RESISTOR CH 1/16W 1.3K	1						
R3108	ERJ2GEJ220	M.RESISTOR CH 1/16W 22	1						
R3109	ERJ2GEJ101	M.RESISTOR CH 1/16W 100	1						
TH3101	ERTJ0EG103HA	THERMISTOR	1						

DMC-FX3EGM-S/K,EF-S/K,EB-S/K,PP-S/K,EG-S/K,GC-S/K,PL-S/K,EE-S/K,GT-S/K,GK-S/K,GN-S/K,GD-S/K

Ref.No.	Part No.	Part Name & Description	Pcs	Remarks	Ref.No.	Part No.	Part Name & Description	Pcs	Remarks
1	VEP51009A	SUB P.C.B.	1	(RTL) E.S.D.	B11	VHD1877	SCREW	1	(BLACK)
2	VEP56039A	MAIN P.C.B.	1	(RTL) E.S.D.	B12	VHD1876	SCREW	1	(SILVER)
3	VG6179	FRAME	1		B12	VHD1877	SCREW	1	(BLACK)
4	VGQ8960	BATTERY LOCK KNOB	1		B13	VHD1876	SCREW	1	(SILVER)
5	VKF4111	JACK DOOR	1	(SILVER)	B13	VHD1877	SCREW	1	(BLACK)
5	VKF4112	JACK DOOR	1	(BLACK)	B14	XQN16+BJ5FN	SCREW	1	
6	VMB3961	BATTERY OUT SPRING	1		B15	XQN16+BJ5FN	SCREW	1	
7	VMB3962	BATTERY LOCK SPRING	1		B16	XQN16+BJ5FN	SCREW	1	
8	VMB3966	BATTERY DOOR SPRING	1		B101	VHD1726	SCREW	1	
9	VMP8647	BATTERY CASE	1		B102	VHD1726	SCREW	1	
10	VMS7598	BATTERY DOOR SHAFT	1		B103	VHD1726	SCREW	1	
11	VMS7704	JACK DOOR SHAFT	1		B104	XQN14+CJ4FJ	SCREW	1	
12	VMS7717	STRAP SHAFT	1		B105	XQN14+CJ4FJ	SCREW	1	
13	VYK1X60	BATTERY DOOR UNIT	1	(SILVER)	B106	XQN14+CJ4FJ	SCREW	1	
13	VYK1X61	BATTERY DOOR UNIT	1	(BLACK)	B107	XQN14+CJ4FJ	SCREW	1	
14	VGQ9161	TOP PCB BARRIER	1		B108	XQN14+CJ4FJ	SCREW	1	
15	VYK1X28	TOP ORNAMENT UNIT	1		B109	XQN14+CJ25FJ	SCREW	1	
15-1	VGU9995	OIS BUTTON	1		B110	XQN14+CJ25FJ	SCREW	1	
16	EFN-FSV71ZC	FLASH UNIT	1						
17	L0AA01A00023	SPEAKER	1						
18	VEE1C78	AF CONNECTOR	1						
19	VEP58032A	FLASH TOP P.C.B.	1	(RTL) E.S.D.					
20	VEP59029A	AF ASSIST LED P.C.B.	1	(RTL) E.S.D.					
21	VGQ9015	FLASH COVER	1						
22	VGU9816	POWER KNOB	1						
23	VGU9954KIT	MODE DIAL	1						
24	VYQ3750	MIC DAMPER	1						
25	F2A2F8000005	E.CAPACITOR 300V 95U	1	(C8003)					
26	VSQ1235	EARTH SPRING	1	(ET8003)					
27	ML-421S/ZT	BATTERY	1	(MBI)(Z9101)					
28	VGQ8229	ZOOM SHEET	1						
29	VGQ8451	LENS SHEET	1						
30	VGQ8798	PCB SPACER	1						
31	VMP8650	TORIPOD	1						
32	VYK1X21	FRONT CASE UNIT	1	(SILVER)					
32	VYK1X22	FRONT CASE UNIT	1	(BLACK)					
33	VGK3235	REAR PANEL LIGHT	1	(SILVER)					
33	VGK3236	REAR PANEL LIGHT	1	(BLACK)					
34	VGL1183	REAR PANEL LIGHT	1						
35	VGU9994	CARSOR BUTTON	1						
36	VYK1X25	LCD UNIT	1						
37	VYK1X68	REAR CASE UNIT	1	(SILVER)					
37	VYK1X69	REAR CASE UNIT	1	(BLACK)					
38	VMX3580	JYRO BARRIER	1						
100	VXW0822	LENS UNIT	1						
101	VDL1603	OPTICAL FILTER	1						
102	VEK0K30	CCD UNIT	1	E.S.D.					
103	VMB3683	CCD SPRING	1						
104	VMB3683	CCD SPRING	1						
105	VMX3437	CCD CUSHION RUBBER	1						
106	L6DA8BEC0001	ZOOM MOTOR UNIT	1						
110	VXP2658	1ST LENS FRAME UNIT	1						
112	VDW1335	DIRECT FRAME	1						
113	VDW1275	DRIVE FRAME	1						
114	VXQ1443	FIX FRAME UNIT	1						
116	VMA0S85	COVER	1						
B1	VHD1843	SCREW	1						
B2	VHD1843	SCREW	1						
B3	VHD1694	SCREW	1						
B4	VHD1678	SCREW	1						
B5	VHD1876	SCREW	1	(SILVER)					
B5	VHD1877	SCREW	1	(BLACK)					
B6	VHD1876	SCREW	1	(SILVER)					
B6	VHD1877	SCREW	1	(BLACK)					
B7	VHD1876	SCREW	1	(SILVER)					
B7	VHD1877	SCREW	1	(BLACK)					
B8	VHD1876	SCREW	1	(SILVER)					
B8	VHD1877	SCREW	1	(BLACK)					
B9	VHD1876	SCREW	1	(SILVER)					
B9	VHD1877	SCREW	1	(BLACK)					
B10	VHD1876	SCREW	1	(SILVER)					
B10	VHD1877	SCREW	1	(BLACK)					
B11	VHD1876	SCREW	1	(SILVER)					

DMC-FX3EGM-S/K,EF-S/K,EB-S/K,PP-S/K,EG-S/K,GC-S/K,PL-S/K,EE-S/K,GT-S/K,GK-SS

Ref.No.	Part No.	Part Name & Description	Pcs	Remarks
200	VPF1224	CAMERA BAG	1	(EXCEPT PP)
△ 201	-----	BATTERY	1	(EXCEPT PP)
△ 202	DE-A12AB	BATTERY CHARGER	1	EGM,EF,EB,EG,GN
△ 202	DE-A12BB	BATTERY CHARGER	1	GC,EE,GK,GD
△ 202	DE-A11BC	BATTERY CHARGER	1	PL
△ 202	DE-A12CB	BATTERY CHARGER	1	GT
204	VFC4090	HAND STRAP	1	(EXCEPT PP)
205	VFF0340-S	CD-ROM	1	(EXCEPT PP)
207	VPK3166	PACKING CASE	1	EGM-S,EF-S,EB-S,EG-S,GC-S PL-S,EE-S,GT-S,GN-S,GD-S
207	VPK3169	PACKING CASE	1	EGM-K,EF-K,EB-K,EG-K,GC-K PL-K,EE-K,GT-K,GN-K,GD-K
207	VPK3167	PACKING CASE	1	GK-S
207	VPK3170	PACKING CASE	1	GK-K
208	VPN6407	CUSHION	1	(EXCEPT PP)
210	VYQ3509	BATTERY PROTECTION CASE U	1	(EXCEPT PP)
211	K1HA08CD0007	USB CABLE	1	(EXCEPT PP)
212	K1HA08CD0008	AV CABLE	1	(EXCEPT PP)
213	VPF1132	POLY BAG	1	EGM,EG,GC,PL
213	VPF1100	BAG,POLYETHYLENE	1	EF,EB,EE,GT,GK,GN,GD
△ 214	VQT0Y78	INSTRUCTION BOOK	1	EGM (SPANISH)
△ 214	VQT0Y79	INSTRUCTION BOOK	1	EGM (PORTUGUESE)
△ 214	VQT0Y80	INSTRUCTION BOOK	1	EGM (SWEDISH)
△ 214	VQT0Y81	INSTRUCTION BOOK	1	EGM (DANISH)
△ 214	VQT0Y75	INSTRUCTION BOOK	1	EF,EG (FRENCH)
△ 214	VQT0Y82	INSTRUCTION BOOK	1	EB (ENGLISH)
△ 214	VQT0Y74	INSTRUCTION BOOK	1	EG (GERMAN)
△ 214	VQT0Y76	INSTRUCTION BOOK	1	EG (ITALIAN)
△ 214	VQT0Y77	INSTRUCTION BOOK	1	EG (DUTCH)
△ 214	VQT0Y85	INSTRUCTION BOOK	1	GC (ENGLISH)
△ 214	VQT0Y86	INSTRUCTION BOOK	1	GC (CHINESE(TRADITIONAL))
△ 214	VQT0Y87	INSTRUCTION BOOK	1	GC (ARABIC)
△ 214	VQT0Y88	INSTRUCTION BOOK	1	GC (PERSIAN)
△ 214	VQT0Y71	INSTRUCTION BOOK	1	PL (ENGLISH)
△ 214	VQT0Y72	INSTRUCTION BOOK	1	PL (SPANISH)
△ 214	VQT0Y73	INSTRUCTION BOOK	1	PL (PORTUGUESE)
△ 214	VQT0Y83	INSTRUCTION BOOK	1	EE (RUSSIAN)
△ 214	VQT0Y84	INSTRUCTION BOOK	1	EE (UR)
△ 214	VQT0Y90	INSTRUCTION BOOK	1	GT (CHINESE(TRADITIONAL))
△ 214	VQT0Y91	INSTRUCTION BOOK	1	GK (CHINESE(SIMPLIFIED))
△ 214	VQT0Y92	INSTRUCTION BOOK	1	GN (ENGLISH)
△ 214	VQT0Y93	INSTRUCTION BOOK	1	GD (KOREAN)
215	VQT0W44	O/I PC CONNECTOR	1	EGM (SPANISH/PORTUGUESE/ SWEDISH/DANISH)
215	VQT0W45	O/I PC CONNECTOR	1	EF (FRENCH)
215	VQT0W46	O/I PC CONNECTOR	1	EB (ENGLISH)
215	VQT0W43	O/I PC CONNECTOR	1	EG (GERMAN/FRENCH/ITALIAN/ DUTCH)

Ref.No.	Part No.	Part Name & Description	Pcs	Remarks
215	VQT0Y12	O/I PC CONNECTOR	1	GC (ENGLISH/ARABIC/PERSIAN/ CHINESE(TRADITIONAL))
215	VQT0W42	O/I PC CONNECTOR	1	PL (ENGLISH/SPANISH/ PORTUGUESE)
215	VQT0W14	O/I PC CONNECTOR	1	EE (RUSSIAN/UR)
215	VQT0W48	O/I PC CONNECTOR	1	GT (CHINESE(TRADITIONAL))
215	VQT0W49	O/I PC CONNECTOR	1	GK (CHINESE(SIMPLIFIED))
215	VQT0W50	O/I PC CONNECTOR	1	GN (ENGLISH)
215	VQT0W51	O/I PC CONNECTOR	1	GD (KOREAN)
216	VQT1A75	O/I SOFTWARE	1	EGM (SPANISH/PORTUGUESE/ SWEDISH/DANISH)
216	VQT1A76	O/I SOFTWARE	1	EF (FRENCH)
216	VQT1A77	O/I SOFTWARE	1	EB,GN (ENGLISH)
216	VQT1A74	O/I SOFTWARE	1	EG (GERMAN/FRENCH/ITALIAN/ DUTCH)
216	VQT0Y89	O/I SOFTWARE	1	GC (ENGLISH/ARABIC/PERSIAN/ CHINESE(TRADITIONAL))
216	VQT1A73	O/I SOFTWARE	1	PL (ENGLISH/SPANISH/ PORTUGUESE)
216	VQT1A78	O/I SOFTWARE	1	EE (RUSSIAN/UR)
216	VQT1A79	O/I SOFTWARE	1	GT (CHINESE(TRADITIONAL))
216	VQT1A80	O/I SOFTWARE	1	GK (CHINESE(SIMPLIFIED))
216	VQT1A81	O/I SOFTWARE	1	GD (KOREAN)
△ 219	K2CQ2CA00006	AC CABLE W/PLUG	1	EGM,EF,EG,GC,EE
△ 220	K2CT3CA00004	AC CABLE W/PLUG	1	EB,GC
△ 221	K2CA2CA00027	AC CABLE W/PLUG	1	GT
△ 221	K2CA2CA00020	AC CABLE W/PLUG	1	GK
△ 222	K2CJ2DA00008	AC CABLE W/PLUG	1	GN
△ 223	RJA0078-1X	AC CABLE W/PLUG	1	GD

S7. Exploded View

S7.1. Frame and Casing Section

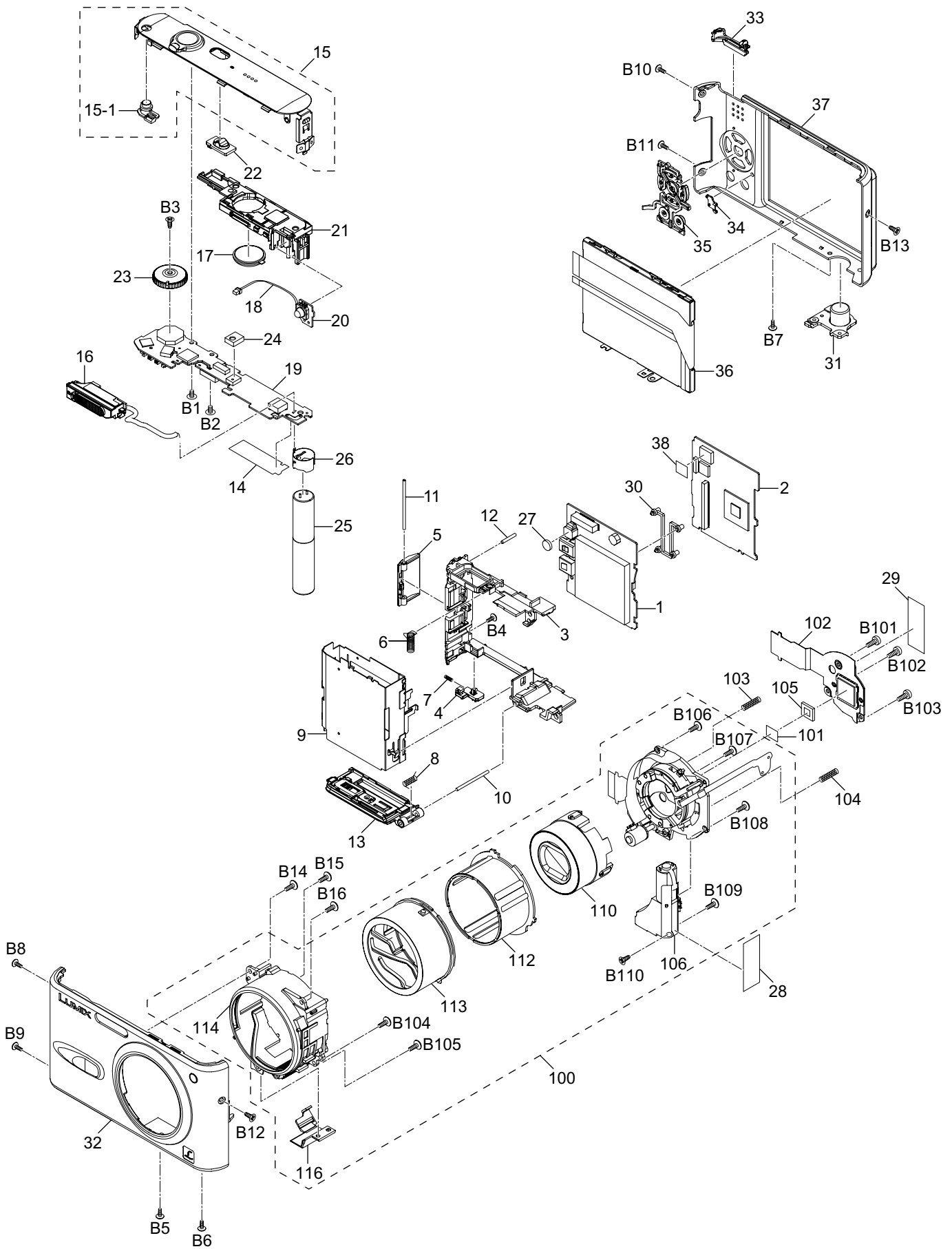

S7.2. Packing Parts and Accessories Section (1)

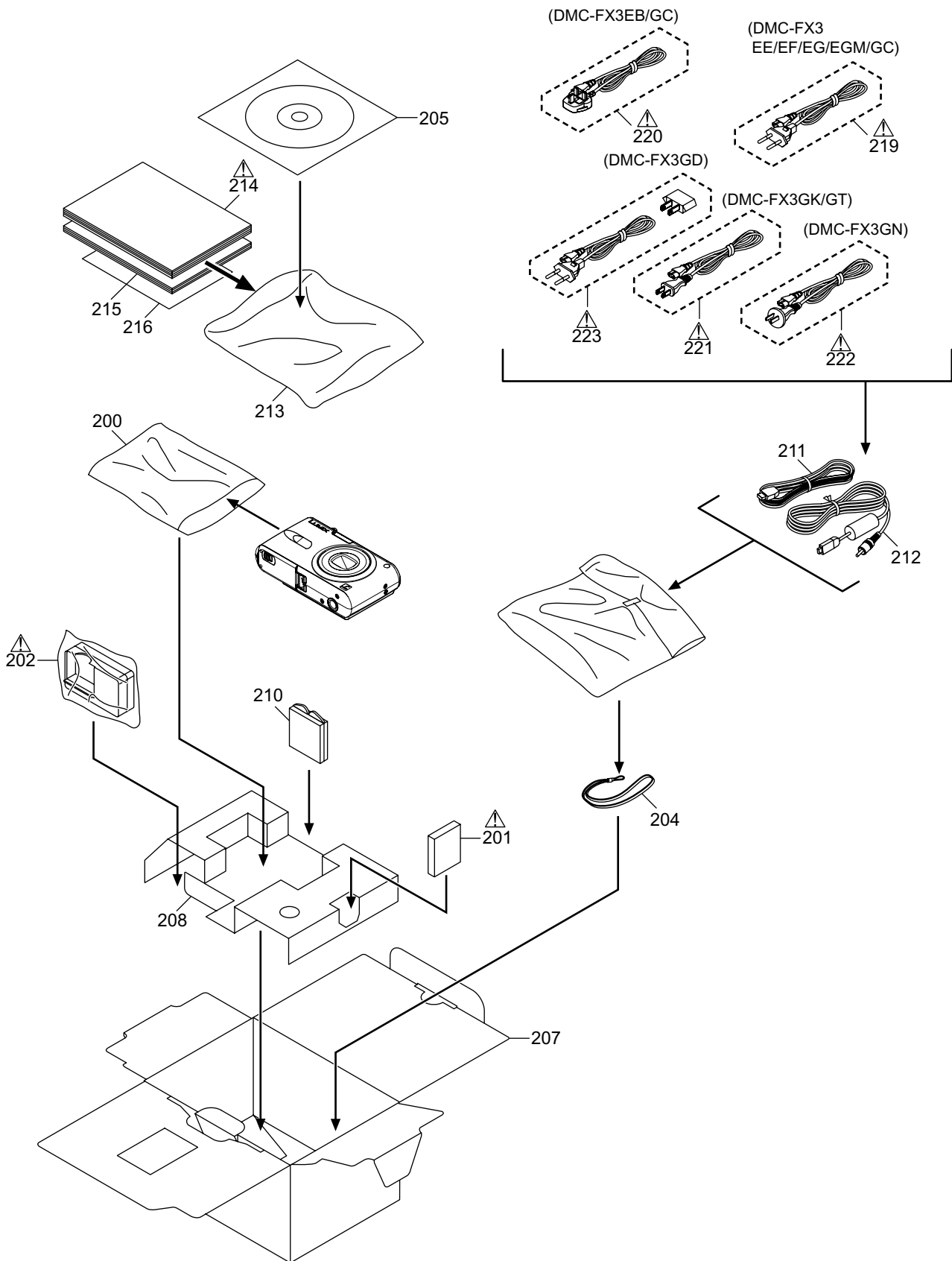

S7.3. Packing Parts and Accessories Section (2)

