

Service Manual

Digital Camera

LUMIX
LEICA
DC VARIO-ELMARIT

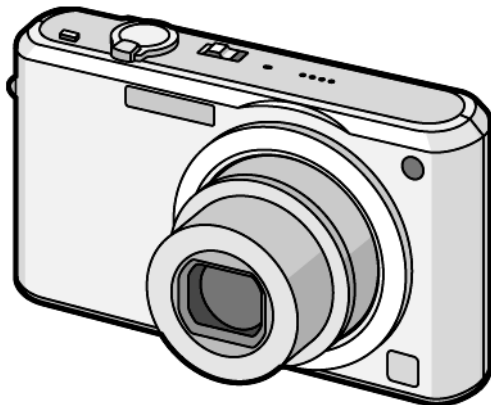

Model No. **DMC-FX100P**
DMC-FX100PC
DMC-FX100PL
DMC-FX100E
DMC-FX100EB
DMC-FX100EE
DMC-FX100EF
DMC-FX100EG
DMC-FX100GC
DMC-FX100GD
DMC-FX100GK
DMC-FX100GN
DMC-FX100GT
DMC-FX100SG

Vol. 1

Colour

(S).....Silver Type (except GD)

(K).....Black Type

(N).....Gold Type (except P/PC/E/EB/EG/GN/GT)

WARNING

This service information is designed for experienced repair technicians only and is not designed for use by the general public. It does not contain warnings or cautions to advise non-technical individuals of potential dangers in attempting to service a product. Products powered by electricity should be serviced or repaired only by experienced professional technicians. Any attempt to service or repair the product or products dealt with in this service information by anyone else could result in serious injury or death.

Panasonic[®]

© 2007 Matsushita Electric Industrial Co., Ltd. All rights reserved. Unauthorized copying and distribution is a violation of law.

TABLE OF CONTENTS

	PAGE	PAGE
1 Safety Precaution	3	
1.1. General Guidelines	3	
1.2. Leakage Current Cold Check	3	
1.3. Leakage Current Hot Check (See Figure 1.)	3	
1.4. How to Discharge the Capacitor on Flash Top PCB	4	
2 Warning	5	
2.1. Prevention of Electrostatic Discharge (ESD) to Electrostatically Sensitive (ES) Devices	5	
2.2. How to Recycle the Lithium Ion Battery (U.S. Only)	5	
2.3. Caution for AC Cord(For EB/GC/SG)	6	
2.4. How to Replace the Lithium Battery	7	
3 Service Navigation	8	
3.1. Introduction	8	
3.2. General Description About Lead Free Solder (PbF)	8	
3.3. Important Notice 1:(Other than U.S.A. and Canadian Market)	8	
3.4. How to Define the Model Suffix (NTSC or PAL model)	9	
4 Specifications	12	
5 Location of Controls and Components	13	
6 Service Mode	14	
6.1. Error Code Memory Function	14	
7 Service Fixture & Tools	17	
7.1. Service Fixture and Tools	17	
7.2. When Replacing the Main PCB	18	
7.3. Service Position	18	
8 Disassembly and Assembly Instructions	19	
8.1. Disassembly Flow Chart	19	
8.2. PCB Location	19	
8.3. Disassembly Procedure	20	
8.4. Disassembly Procedure for the Lens	25	
8.5. Assembly Procedure for the Lens	27	
8.6. Removal of the CCD Unit	30	
8.7. The Applymt of Grease Method	31	
9 Measurements and Adjustments	32	
9.1. Matrix Chart for Replaced Part and Necessary Adjustment	32	
10 Maintenance	33	
10.1. Cleaning Lens and LCD Panel	33	

1 Safety Precaution

1.1. General Guidelines

1. IMPORTANT SAFETY NOTICE

There are special components used in this equipment which are important for safety. These parts are marked by

 in the Schematic Diagrams, Circuit Board Layout, Exploded Views and Replacement Parts List. It is essential that these critical parts should be replaced with manufacturer's specified parts to prevent X-RADIATION, shock, fire, or other hazards. Do not modify the original design without permission of manufacturer.

2. An Isolation Transformer should always be used during the servicing of AC Adaptor whose chassis is not isolated from the AC power line. Use a transformer of adequate power rating as this protects the technician from accidents resulting in personal injury from electrical shocks. It will also protect AC Adaptor from being damaged by accidental shorting that may occur during servicing.
3. When servicing, observe the original lead dress. If a short circuit is found, replace all parts which have been overheated or damaged by the short circuit.
4. After servicing, see to it that all the protective devices such as insulation barriers, insulation papers shields are properly installed.
5. After servicing, make the following leakage current checks to prevent the customer from being exposed to shock hazards.

1.2. Leakage Current Cold Check

1. Unplug the AC cord and connect a jumper between the two prongs on the plug.
2. Measure the resistance value, with an ohmmeter, between the jumpered AC plug and each exposed metallic cabinet part on the equipment such as screwheads, connectors, control shafts, etc. When the exposed metallic part has a return path to the chassis, the reading should be between $1\text{ M}\Omega$ and $5.2\text{ M}\Omega$. When the exposed metal does not have a return path to the chassis, the reading must be infinity.

1.3. Leakage Current Hot Check (See Figure 1.)

1. Plug the AC cord directly into the AC outlet. Do not use an isolation transformer for this check.
2. Connect a $1.5\text{ k}\Omega$, 10 W resistor, in parallel with a $0.15\text{ }\mu\text{F}$ capacitor, between each exposed metallic part on the set and a good earth ground, as shown in Figure 1.
3. Use an AC voltmeter, with $1\text{ k}\Omega/\text{V}$ or more sensitivity, to measure the potential across the resistor.
4. Check each exposed metallic part, and measure the voltage at each point.
5. Reverse the AC plug in the AC outlet and repeat each of the above measurements.
6. The potential at any point should not exceed 0.75 V RMS . A leakage current tester (Simpson Model 229 or equivalent) may be used to make the hot checks, leakage current must not exceed $1/2\text{ mA}$. In case a measurement is outside of the limits specified, there is a possibility of a shock hazard, and the equipment should be repaired and rechecked before it is returned to the customer.

Hot-Check Circuit

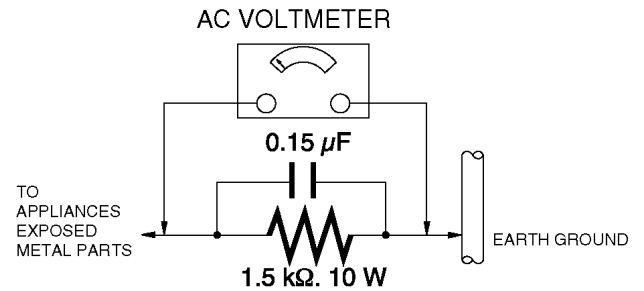

Figure. 1

1.4. How to Discharge the Capacitor on Flash Top PCB

CAUTION:

1. Be sure to discharge the capacitor on FLASH TOP PCB.
2. Be careful of the high voltage circuit on FLASH TOP PCB when servicing.

[Discharging Procedure]

1. Refer to the disassemble procedure and Remove the necessary parts/unit.
2. Put the insulation tube onto the lead part of Resistor (ERG5SJ102:1k Ω /5W).
(an equivalent type of resistor may be used.)
3. Put the resistor between both terminals of capacitor on FLASH TOP PCB for approx. 5 seconds.
4. After discharging confirm that the capacitor voltage is lower than 10V using a voltmeter.

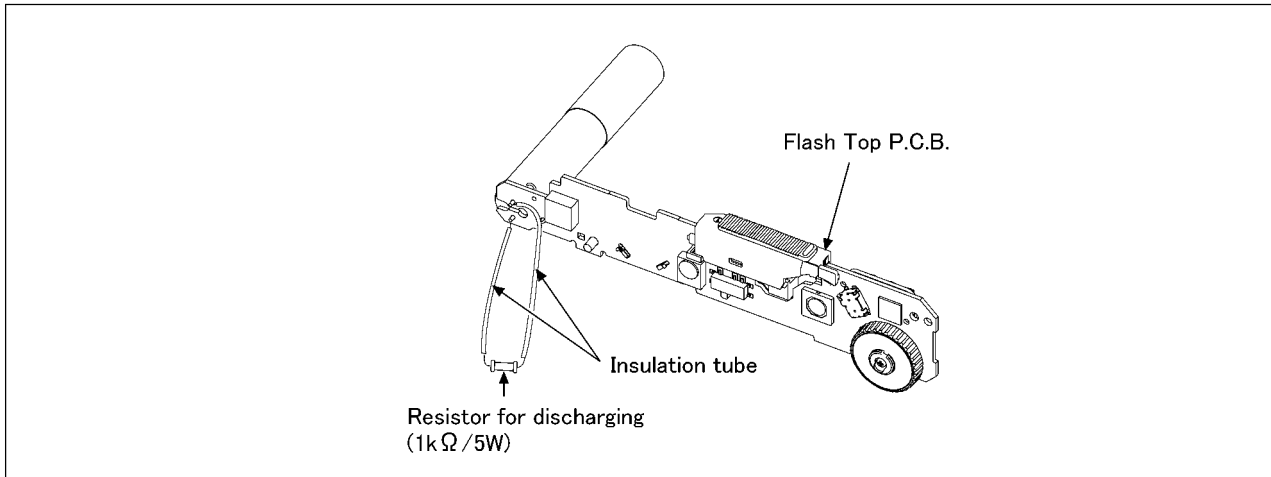

Fig. F1

2 Warning

2.1. Prevention of Electrostatic Discharge (ESD) to Electrostatically Sensitive (ES) Devices

Some semiconductor (solid state) devices can be damaged easily by static electricity. Such components commonly are called Electrostatically Sensitive (ES) Devices.

Examples of typical ES devices are CCD image sensor, IC (integrated circuits) and some field-effect transistors and semiconductor "chip" components.

The following techniques should be used to help reduce the incidence of component damage caused by electrostatic discharge (ESD).

1. Immediately before handling any semiconductor component or semiconductor-equipped assembly, drain off any ESD on your body by touching a known earth ground. Alternatively, obtain and wear a commercially available discharging ESD wrist strap, which should be removed for potential shock reasons prior to applying power to the unit under test.
2. After removing an electrical assembly equipped with ES devices, place the assembly on a conductive surface such as aluminum foil, to prevent electrostatic charge buildup or exposure of the assembly.
3. Use only a grounded-tip soldering iron to solder or unsolder ES devices.
4. Use only an antistatic solder removal device. Some solder removal devices not classified as "antistatic (ESD protected)" can generate electrical charge sufficient to damage ES devices.
5. Do not use freon-propelled chemicals. These can generate electrical charges sufficient to damage ES devices.
6. Do not remove a replacement ES device from its protective package until immediately before you are ready to install it. (Most replacement ES devices are packaged with leads electrically shorted together by conductive foam, aluminum foil or comparable conductive material).
7. Immediately before removing the protective material from the leads of a replacement ES device, touch the protective material to the chassis or circuit assembly into which the device will be installed.

CAUTION :

Be sure no power is applied to the chassis or circuit, and observe all other safety precautions.

8. Minimize bodily motions when handling unpackaged replacement ES devices. (Otherwise harmless motion such as the brushing together of your clothes fabric or the lifting of your foot from a carpeted floor can generate static electricity (ESD) sufficient to damage an ES device).

2.2. How to Recycle the Lithium Ion Battery (U.S. Only)

ENGLISH



A lithium ion/polymer battery that is recyclable powers the product you have purchased. Please call 1-800-8-BATTERY for information on how to recycle this battery.

FRANÇAIS



L'appareil que vous vous êtes procuré est alimenté par une batterie au lithium-ion/polymère recyclable. Pour des renseignements sur le recyclage de la batterie, veuillez composer le 1-800-8-BATTERY.

2.3. Caution for AC Cord (For EB/GC/SG)

2.3.1. Information for Your Safety

IMPORTANT

Your attention is drawn to the fact that recording of pre-recorded tapes or discs or other published or broadcast material may infringe copyright laws.

WARNING

To reduce the risk of fire or shock hazard, do not expose this equipment to rain or moisture.

CAUTION

To reduce the risk of fire or shock hazard and annoying interference, use the recommended accessories only.

FOR YOUR SAFETY

DO NOT REMOVE THE OUTER COVER

To prevent electric shock, do not remove the cover. No user serviceable parts inside. Refer servicing to qualified service personnel.

2.3.2. Caution for AC Mains Lead

For your safety, please read the following text carefully.

This appliance is supplied with a moulded three-pin mains plug for your safety and convenience.

A 5-ampere fuse is fitted in this plug.

Should the fuse need to be replaced please ensure that the replacement fuse has a rating of 5 amperes and it is approved by ASTA or BSI to BS1362

Check for the ASRA mark or the BSI mark on the body of the fuse.



If the plug contains a removable fuse cover you must ensure that it is refitted when the fuse is replaced.

If you lose the fuse cover, the plug must not be used until a replacement cover is obtained.

A replacement fuse cover can be purchased from your local Panasonic Dealer.

If the fitted moulded plug is unsuitable for the socket outlet in your home then the fuse should be removed and the plug cut off and disposed of safely.

There is a danger of severe electrical shock if the cut off plug is inserted into any 13-ampere socket.

If a new plug is to be fitted please observe the wiring code as shown below.

If in any doubt, please consult a qualified electrician.

2.3.2.1. Important

The wires in this mains lead are coloured in accordance with the following code:

Blue	Neutral
Brown	Live

As the colours of the wires in the mains lead of this appliance may not correspond with the coloured markings identifying the terminals in your plug, proceed as follows:

The wire which is coloured BLUE must be connected to the terminal in the plug which is marked with the letter N or coloured BLACK.

The wire which is coloured BROWN must be connected to the terminal in the plug which is marked with the letter L or coloured RED.

Under no circumstances should either of these wires be connected to the earth terminal of the three pin plug, marked with the letter E or the Earth Symbol.



2.3.2.2. Before Use

Remove the Connector Cover as follows.

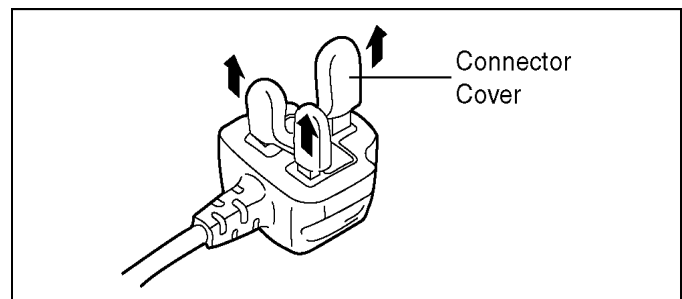

2.3.2.3. How to Replace the Fuse

1. Remove the Fuse Cover with a screwdriver.

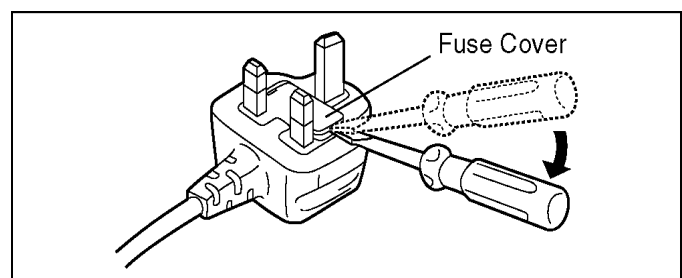

2. Replace the fuse and attach the Fuse cover.

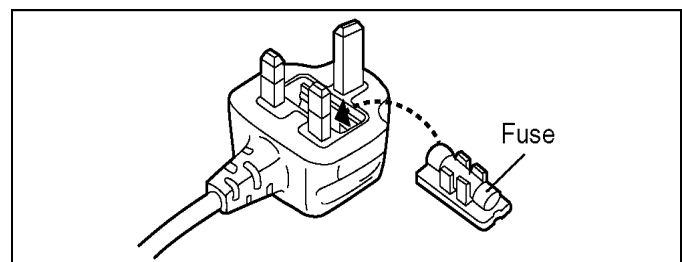

2.4. How to Replace the Lithium Battery

2.4.1. Replacement Procedure

1. Remove the SUB PCB. (Refer to Disassembly Procedures.)
2. Remove the Lithium battery (Ref. No. "B9801" at component side of SUB PCB) and then replace it into new one.

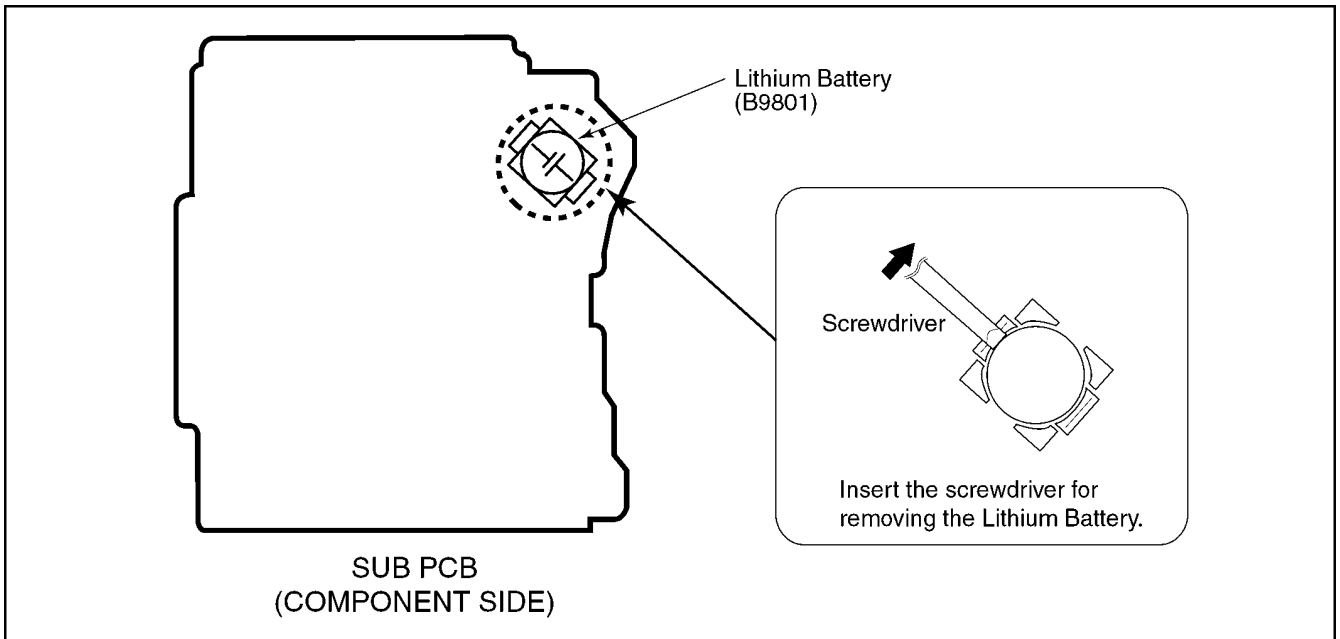

NOTE:

This Lithium battery is a critical component.

(Type No.: ML421S/ZT **Manufactured by Matsushita Battery Industrial Co.,Ltd.**)

It must never be subjected to excessive heat or discharge.

It must therefore only be fitted in requirement designed specifically for its use.

Replacement batteries must be of same type and manufacture.

They must be fitted in the same manner and location as the original battery, with the correct polarity contacts observed.

Do not attempt to re-charge the old battery or re-use it for any other purpose.

It should be disposed of in waste products destined for burial rather than incineration.

(For English)

CAUTION

Danger of explosion if battery is incorrectly replaced.

Replace only with the same or equivalent type recommended by the manufacturer.

Dispose of used batteries according to the manufacturer's instructions.

(For German)

ACHTUNG

Explosionsgefahr bei falschem Anbringen der Batterie. Ersetzen Sie nur mit einem äquivalentem vom Hersteller empfohlenem Typ.

Behandeln Sie gebrauchte Batterien nach den Anweisungen des Herstellers.

(For French)

MISE EN GARDE

Une batterie de remplacement inappropriée peut exploser. Ne remplacez qu'avec une batterie identique ou d'un type recommandé par le fabricant. L'élimination des batteries usées doit être faite conformément aux instructions du manufacturier.

NOTE:

Above caution is applicable for a battery pack which is for DMC-FX100 series, as well.

3 Service Navigation

3.1. Introduction

This service manual contains technical information, which allow service personnel's to understand and service this model.

Please place orders using the parts list and not the drawing reference numbers.

If the circuit is changed or modified, the information will be followed by service manual to be controlled with original service manual.

3.2. General Description About Lead Free Solder (PbF)

The lead free solder has been used in the mounting process of all electrical components on the printed circuit boards used for this equipment in considering the globally environmental conservation.

The normal solder is the alloy of tin (Sn) and lead (Pb). On the other hand, the lead free solder is the alloy mainly consists of tin (Sn), silver (Ag) and Copper (Cu), and the melting point of the lead free solder is higher approx.30°C (86°F) more than that of the normal solder.

Distinction of PCB Lead Free Solder being used

The letter of "PbF" is printed either foil side or components side on the PCB using the lead free solder.(See right figure)

PbF

Service caution for repair work using Lead Free Solder (PbF)

- The lead free solder has to be used when repairing the equipment for which the lead free solder is used.
(Definition: The letter of "PbF" is printed on the PCB using the lead free solder.)
- To put lead free solder, it should be well molten and mixed with the original lead free solder.
- Remove the remaining lead free solder on the PCB cleanly for soldering of the new IC.
- Since the melting point of the lead free solder is higher than that of the normal lead solder, it takes the longer time to melt the lead free solder.
- Use the soldering iron (more than 70W) equipped with the temperature control after setting the temperature at 350±30°C (662±86°F).

Recommended Lead Free Solder (Service Parts Route.)

- The following 3 types of lead free solder are available through the service parts route.
 - RFKZ03D01K----- (0.3mm 100g Reel)
 - RFKZ06D01K----- (0.6mm 100g Reel)
 - RFKZ10D01K----- (1.0mm 100g Reel)

Note

* Ingredient: tin (Sn) 96.5%, silver (Ag) 3.0%, Copper (Cu) 0.5%, Cobalt (Co) / Germanium (Ge) 0.1 to 0.3%

3.3. Important Notice 1:(Other than U.S.A. and Canadian Market)

1. The service manual does not contain the following information, because of the impossibility of servicing at component level without concerned equipment/facilities.
 - a. Schematic diagram, Block Diagram and PCB layout of MAIN PCB and SUB PCB.
 - b. Parts list for individual parts for MAIN PCB and SUB PCB.

When a part replacement is required for repairing MAIN PCB and/or SUB PCB, replace as an assembled parts. (Main PCB/ SUB PCB)

2. The following category is/are recycle module part. please send it/them to Central Repair Center.
 - MAIN PCB (VEP56048A)
 - SUB PCB (VEP51014A) : Excluding replacement of Lithium Battery

3.4. How to Define the Model Suffix (NTSC or PAL model)

There are seven kinds of DMC-FX100, regardless of the colours.







- a) DMC-FX100S
- b) DMC-FX100P/PC
- c) DMC-FX100E/EB/EF/EG/GN
- d) DMC-FX100EE
- e) DMC-FX100GD
- f) DMC-FX100GT
- g) DMC-FX100PL/GC/GK/SG

(DMC-FX100S is exclusively Japan domestic model.)

What is the difference is that the "INITIAL SETTINGS" data which is stored in Flash ROM mounted on Main PCB.

3.4.1. Defining methods:

To define the model suffix to be serviced, refer to the nameplate which is putted on the bottom side of the Unit.

<p>a) DMC-FX100S DMC-FX100S is exclusively Japan domestic model.</p> <p>b) DMC-FX100P/PC The nameplate for these models show the following Safety registration mark.</p> <div style="border: 1px solid black; padding: 5px; text-align: center;">  </div> <p>c) DMC-FX100E/EB/EF/EG/GN The nameplate for these models show the following Safety registration mark.</p> <div style="border: 1px solid black; padding: 5px; text-align: center;">  </div> <p>d) DMC-FX100EE The nameplate for this model show the following Safety registration mark.</p> <div style="border: 1px solid black; padding: 5px; text-align: center;">  </div> <p>e) DMC-FX100GD The nameplate for this model show the following Safety registration mark.</p> <div style="border: 1px solid black; padding: 5px; text-align: center;">  </div> <p>f) DMC-FX100GT The nameplate for this model show the following Safety registration mark.</p> <div style="border: 1px solid black; padding: 5px; text-align: center;">  </div> <p>g) DMC-FX100PL/GC/GK/SG The nameplate for these models do not show any above Safety registration mark.</p>	<div style="border: 1px solid black; padding: 10px;">  <p style="text-align: center; border: 1px solid black; padding: 2px;">Safety registration mark</p> </div>
--	---

NOTE:

After replacing the MAIN PCB, be sure to achieve adjustment.

The adjustment instruction is available at "software download" on the "Support Information from NWBG/VDBG-PAVC" web-site in "TSN system", together with Maintenance software.

3.4.2. INITIAL SETTINGS:

When you replace the Main PCB, be sure to perform the initial settings after achieving the adjustment by ordering the following procedure in accordance with model suffix of the unit.

1. IMPORTANT NOTICE:

Before proceeding Initial settings, be sure to read the following CAUTIONS.

CAUTION 1 (Initial Settings)

DO NOT select "NONE(JAPAN)" or "P"(North America) if need to select "EG/E/PL/GD/GC/SG/GT/GK/EF/EB/EE/GN and PC".

Otherwise, once "NONE(JAPAN)" or "P"(North America) are selected, "EG/E/PL/GD/GC/SG/GT/GK/EF/EB/EE/GN and PC" will not displayed, thus, RE-Settings (changing area) can not be made.

CAUTION 2 (Picture back up from "Built-in Memory")

This unit employs "Built-in Memory" for picture image data recording.(Approx.27MB)

Be sure to make picture data back up (i.e., Copying to SD memory card), before proceeding "INITIAL SETTINGS".

Once "INITIAL SETTINGS" has been carried out, all image data stored at "Built-in Memory" is erased.

2. PROCEDURES:

- Preparation. Proceed the picture back up from the unit (Refer to above "CAUTION 2")

• Step 1. The temporary cancellation of initial setting:

Set the mode dial to "[Normal picture mode] (Red camera mark)".

While keep pressing [E.ZOOM] and "[UP] of Cross key" simultaneously, turn the Power on.

• Step 2. The cancellation of initial setting:

Set the mode dial to "[Playback]".

Press [E.ZOOM] and "[UP] of Cross key" simultaneously, then turn the Power off.

• Step 3. Turn the Power on:

Set the mode dial to "[Normal picture mode] (Red camera mark)", and then turn the Power on.

• Step 4. Display the INITIAL SETTING:

While keep pressing [MENU] and "[RIGHT] of Cross key" simultaneously, turn the Power off.

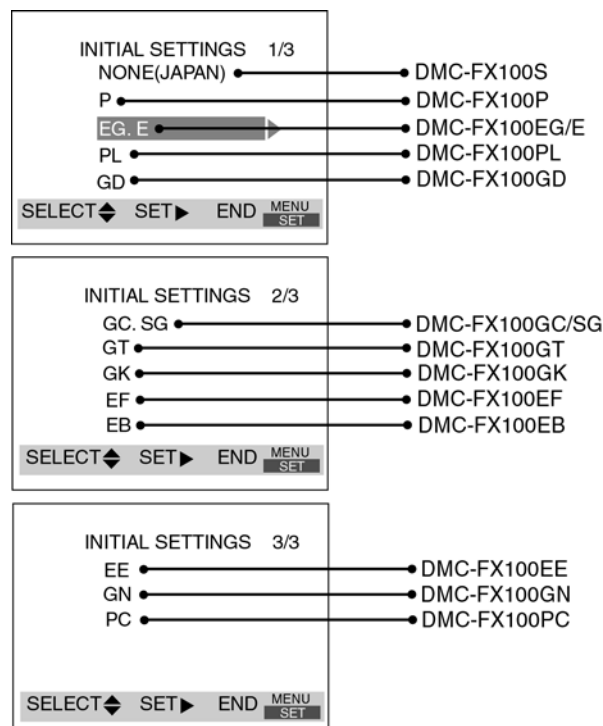

• **Step 5. Set the INITIAL SETTING: (Refer to “CAUTION 1”)**

[Caution for before settings]

Once "NONE(JAPAN)" (Area for Japan) or "P" (Area for North America) is selected with "INITIAL SETTINGS", other areas will not be displayed even if "INITIAL SETTINGS" menu is displayed again, thus, the area can not be changed.

Select the area carefully.

Select the area with pressing “[UP] / [DOWN] of Cross key”, and then press the “[RIGHT] of Cross key”.

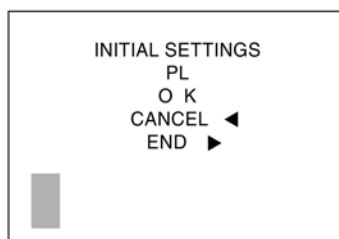

The only set area is displayed, and then press the “[RIGHT] of Cross key” after confirmation.

(The unit is powered off automatically.)

Confirm the display of “PLEASE SET THE CLOCK” in English when the unit is turned on again.

• **Step 6. CONFIRMATION:**

The display shows “PLEASE SET THE CLOCK” when turn the Power on again.

When the unit is connected to PC with USB cable, it is detected as removable media.

(When the “GT” or “GK” model suffix is selected, the display shows “PLEASE SET THE CLOCK” in Chinese.)

1) As for your reference Default setting condition is given in the following table.

• **Default setting (After “INITIAL SETTINGS”)**

	MODEL	VIDEO OUTPUT	LANGUAGE	DATE	REMARKS
a)	DMC-FX100S	NTSC	Japanese	Year/Month/Date	
b)	DMC-FX100P/PC/PL	NTSC	English	Month/Date/Year	
c)	DMC-FX100E/EB/EG/GC/GN/SG	PAL	English	Date/Month/Year	
d)	DMC-FX100EF	PAL	French	Date/Month/Year	
e)	DMC-FX100EE	PAL	Russian	Date/Month/Year	
f)	DMC-FX100GK	PAL	Chinese (simplified)	Year/Month/Date	
g)	DMC-FX100GT	NTSC	Chinese (traditional)	Year/Month/Date	
h)	DMC-FX100GD	NTSC	Korean	Year/Month/Date	

4 Specifications

Digital Camera: Information for your safety

Power Source:	DC 5.1 V
Power Consumption:	1.6 W (When recording) 0.8 W (When playing back)

Camera effective pixels: 12,200,000 pixels
Image sensor: 1/1.72" CCD, total pixel number 12,400,000 pixels, Primary color filter
Lens: Optical 3.6× zoom, f=6.0 mm to 21.4 mm (35 mm film camera equivalent: 28 mm to 100 mm)/F2.8 to F5.6
Digital zoom: Max. 4×
Extended optical zoom: Max. 7×
Focus: Normal/Macro, 9-area-focusing/3-area-focusing (High speed)/1-area-focusing (High speed)/1-area-focusing/Spot-focusing
Focus range: Normal: 50 cm (1.64 feet) to ∞
Macro/Simple/Motion picture/Intelligent ISO sensitivity mode: 5 cm (0.16 feet) (Wide)/30 cm (0.98 feet) (Tele) to ∞
Scene mode: There may be differences in the above settings.
Shutter system: Electronic shutter+Mechanical shutter
Motion picture recording: When the aspect ratio setting is [4:3] 640×480 pixels (30 frames/second, 10 frames/second, only when using a Card)
320×240 pixels (30 frames/second, 10 frame/second)
When the aspect ratio setting is [16:9] 1280×720 pixels (15 frames/second, only when using a Card)
848×480 pixels (30 frames/second, 10 frames/second, only when using a Card)
With audio
Burst recording
Burst speed: 2 pictures/second (Normal), Approx. 1 pictures/second (Unlimited)
Number of recordable pictures: Max. 5 pictures (Standard), max. 3 pictures (Fine), Depends on the remaining capacity of the built-in memory or the card (Unlimited).
(Performance in burst recording is only with SD Memory Card/SDHC Memory Card. MultiMediaCard performance will be less.)
Hi-speed burst
Burst speed: 8 pictures/second
Number of recordable pictures: When using the built-in memory: Approx. 25 pictures (immediately after formatting)
When using a Card: Max. 100 pictures (differs depending on the type of Card and the recording conditions)
ISO sensitivity: AUTO/
80/100/200/400/800/1250/1600
[HIGH SENS.] mode: 1600 to 6400
Shutter speed: 8 seconds to 1/2000th of a second
[STARRY SKY] mode: 15 seconds, 30 seconds, 60 seconds
Motion picture mode: 1/30th of a second to 1/13000th of a second
White balance: Auto white balance/Daylight/Cloudy/Shade/Halogen/White set
Exposure (AE): Program AE
Exposure compensation (1/3 EV Step, -2 EV to +2 EV)
Metering mode: Multiple/Center weighted/Spot
LCD monitor: 2.5" low-temperature polycrystalline TFT LCD (Approx. 207,000 pixels) (field of view ratio about 100%)

Flash: Flash range: [ISO AUTO]
Approx. 60 cm (1.97 feet) to 5 m (16.4 feet) (Wide)
AUTO, AUTO/Red-eye reduction, Forced ON (Forced ON/Red-eye reduction), Slow sync./Red-eye reduction, Forced OFF
Microphone: Monaural
Speaker: Monaural
Recording media: Built-in Memory (Approx. 27 MB)/SD Memory Card/SDHC Memory Card/MultiMediaCard (Still pictures only)
Picture size
Still picture: When the aspect ratio setting is [4:3] 4000×3000 pixels, 3264×2448 pixels, 2560×1920 pixels, 2048×1536 pixels, 1600×1200 pixels, 640×480 pixels
When the aspect ratio setting is [3:2] 4000×2672 pixels, 3264×2176 pixels, 2560×1712 pixels, 2048×1360 pixels
When the aspect ratio setting is [16:9] 4000×2248 pixels, 3264×1840 pixels, 2560×1440 pixels, 1920×1080 pixels
Motion pictures: When the aspect ratio setting is [4:3] 640×480 pixels (Only when using a Card), 320×240 pixels
When the aspect ratio setting is [16:9] 1280×720 pixels (Only when using a Card)
848×480 pixels (Only when using a Card)
Quality: Fine/Standard
Recording file format
Still Picture: JPEG (based on "Design rule for Camera File system", based on "Exif 2.21" standard)/DPOF corresponding
Picture with audio: JPEG (based on "Design rule for Camera File system", based on "Exif 2.21" standard)+ "QuickTime" (picture with audio)
Motion pictures: "QuickTime Motion JPEG" (motion pictures with audio)
Interface
Digital: "USB 2.0" (Full Speed)
Analog video/audio: NTSC/PAL Composite (Switched by menu), Audio line output (monaural)
Terminal
[DIGITAL/AV OUT]: Dedicated jack (8 pin)
[DC IN]: Dedicated jack
Dimensions: Approx. 96.7 mm (W)×54.0 mm (H)×24.5 mm (D)
[3 13/16" (W)×2 1/8" (H)×15/16" (D)]
(excluding the projecting parts)
Mass (Weight): Approx. 148 g/5.22 oz (excluding card and battery),
Approx. 176 g/6.21 oz (with card and battery)
Operating temperature: 0 °C to 40 °C (32 °F to 104 °F)
Operating humidity: 10% to 80%
Battery Charger
(Panasonic DE-A41B): Information for your safety

Input:	110 V to 240 V~50/60 Hz, 0.2 A
Output:	CHARGE 4.2 V= 0.8 A

Equipment mobility: Movable
Battery Pack
(lithium-ion)
(Panasonic CGA-S005A): Information for your safety

Voltage/capacity:	3.7 V, 1150 mAh
--------------------------	-----------------

5 Location of Controls and Components

Names of the Components

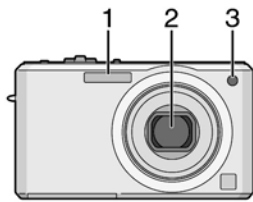

- 1 Flash
- 2 Lens
- 3 Self-timer indicator
AF assist lamp

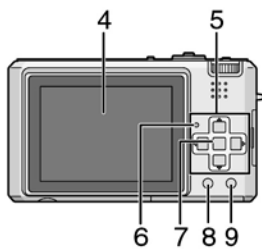

- 4 LCD monitor
- 5 Cursor buttons
 - ◀/Self-timer button
 - ▼/[REV] button
 - ▶/Flash setting button
 - ▲/Exposure compensation /
Auto bracket /
White balance fine adjustment /
Backlight compensation in simple mode
button
- 6 Status indicator
- 7 [MENU/SET] button
- 8 [DISPLAY/LCD MODE] button
- 9 [FUNC]/Delete button

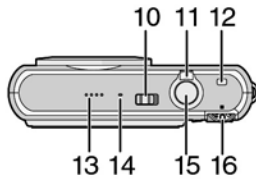

- 10 Camera ON/OFF switch
- 11 Zoom lever
- 12 [E.ZOOM] button
- 13 Speaker
- 14 Microphone
- 15 Shutter button
- 16 Mode dial

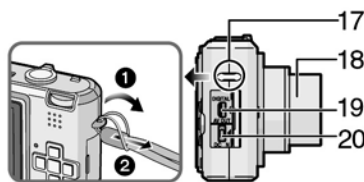

- 17 Strap eyelet
 - We recommend attaching the strap when using the camera to prevent it from dropping.
- 18 Lens barrel
- 19 [DIGITAL/AV OUT] socket
- 20 [DC IN] socket
 - Always use a genuine Panasonic AC adaptor (DMW-AC5PP; optional).
 - This camera cannot charge the battery even though the AC adaptor (DMW-AC5PP; optional) is connected to it.

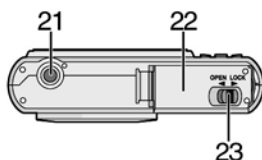

- 21 Tripod receptacle
 - When you use a tripod, make sure the tripod is stable when the camera is attached to it.
- 22 Card/Battery door
- 23 Release lever

About The Mode Dial

If you turn on this unit and then rotate the mode dial, you can not only switch between recording and playback but also switch to macro mode to take a close-up picture of a subject or to a scene mode that matches your recording purpose.

Switching the mode by rotating the mode dial

Align a desired mode with part (A).
Rotate the mode dial slowly and surely to adjust to each mode. (Do not adjust it to parts where there is no mode.)

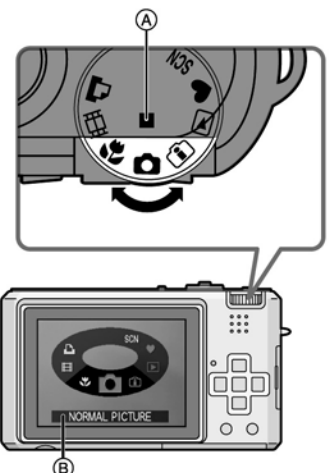

- The above screen (B) appears on the LCD monitor if the mode dial is rotated. The mode currently selected appears on the LCD monitor when the camera is turned on.

Basic

Normal picture mode

Use this mode for normal recording.

Simple mode

This mode is recommended for beginners.

Playback mode

This mode allows you to play back recorded pictures.

Advanced

Intelligent ISO sensitivity mode

This mode automatically sets the optimal ISO sensitivity and shutter speed according to the movement and the brightness of the subject.

Macro mode

This allows you to take close-up pictures of a subject.

SCN Scene mode

This allows you to take pictures that match the scene being recorded.

Motion picture mode

This mode allows you to record motion pictures.

Print mode

Use this to print pictures.

6 Service Mode

6.1. Error Code Memory Function

1. General description

This unit is equipped with history of error code memory function, and can be memorized 16 error codes in sequence from the latest. When the error is occurred more than 16, the oldest error is overwritten in sequence.

The error code is not memorized when the power supply is shut down forcibly (when the unit is powered on by the battery, the battery is pulled out) because the error code is memorized to FLASH ROM when the unit is powered off.

2. How to display

The error code can be displayed by the following procedure:

Before perform the error code memory function, connect the AC adaptor or insert the battery.

(Since this unit has built-in memory, this error code memory function can be performed without inserting SD memory card.)

• 1. The temporary cancellation of initial setting:

Set the mode dial to "[Normal picture mode] (Red camera mark)".

While keep pressing [E.ZOOM] and "[UP] of Cross key" simultaneously, turn the Power on.

• 2. The display of error code:

Press [E.ZOOM], [MENU] and "[LEFT] of Cross key" simultaneously with the step 1 condition.

The display is changed as shown below when the above buttons is pressed simultaneously.

Normal display → Error code display → Operation history display → Normal display →

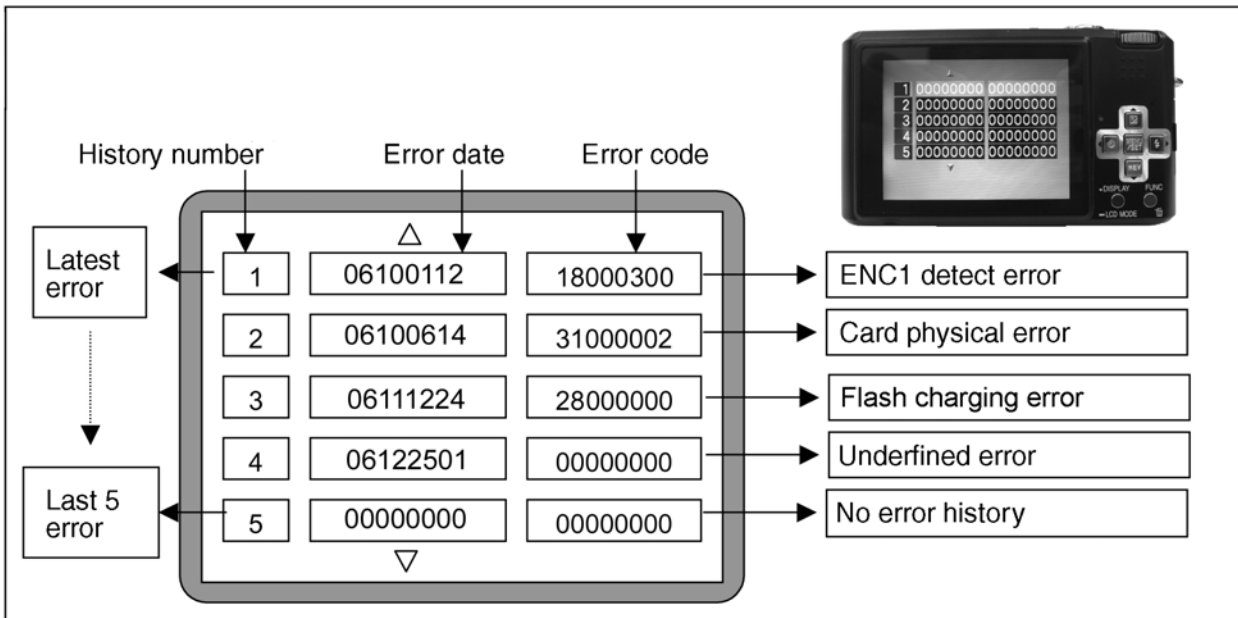

Example of Error Code Display

• 3. The change of display:

The error code can be memorized 16 error codes in sequence, however it is displayed 5 errors on the LCD.

Display can be changed by the following procedure:

"[UP] or [DOWN] of Cross key" : It can be scroll up or down one by one.

"[LEFT] or [RIGHT] of Cross key" : It can be scroll up or down every 5 errors.

• 4. How to read the error date:

The error date code is displayed from the left in order at the year, month, day, time.

Error date information is acquired from "Clock setting" information when the error occurs. When the clock is not setting, it is displayed as "00000000".

• 5. How to read the error code:

One error code is displayed for 8 bit, the contents of error codes is indicated the table as shown below.

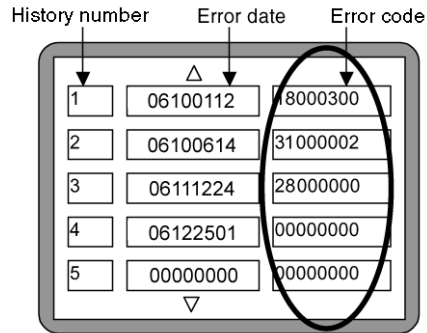

Attribute	Main item	Sub item	Error code		Contents (Upper)
			High 4 bits	Low 4 bits	Check point (Lower)
LENS	Lens drive	OIS	18*0	1000	PSD (X) error. Hall element (X axis) position detect error in OIS unit. OIS Unit
				2000	PSD (Y) error. Hall element (Y axis) position detect error in OIS unit. OIS Unit
				3000	GYRO (X) error. Gyro (IC7102: X axis) detect error on Main P.C.B.. IC7102 (Gyro element) or IC6001 (VENUS 3)
				4000	GYRO (Y) error. Gyro (IC7101: Y axis) detect error on Main P.C.B.. IC7101 (Gyro element) or IC6001 (VENUS 3)
				5000	MREF error (Reference voltage error). IC7001 (LENS drive) or IC6001 (VENUS 3)
				6000	Drive voltage (X) error. VENUS 3 AD value error, LENS Unit, LENS flex breaks etc.
				7000	Drive voltage (Y) error. VENUS 3 AD value error, LENS Unit, LENS flex breaks etc.
		C.B./Zoom	0100	HP Low detect error (C.B. encoder (full retract) always Low detect). FP9802-(31,33) signal line or IC6001 (VENUS 3)	
			0200	HP High detect error (C.B. encoder (full retract) always High detect). FP9802-(32,34) signal line or IC6001 (VENUS 3)	
			0300	ENC1 detect error (C.B. motor encoder detect error). FP9802-(31) signal line or IC6001 (VENUS 3)	
			0400	ENC2 detect error (C.B. motor encoder detect error). FP9802-(33) signal line or IC6001 (VENUS 3)	
			Focus	0001	HP Low detect error (Focus encoder always Low detect error). FP9802-(3) signal line or IC6001 (VENUS 3)
				0002	HP High detect error (Focus encoder always High detect error). FP9802-(2) signal line or IC6001 (VENUS 3)
		Lens	18*1	0000	Power ON time out error. Lens drive system
	18*2			0000	Power OFF time out error. Lens drive system
	Adj.History	OIS	19*0	2000	OIS adj. Yaw direction amplitude error (small)
				3000	OIS adj. Pitch direction amplitude error (small)
				4000	OIS adj. Yaw direction amplitude error (large)
				5000	OIS adj. Pitch direction amplitude error (large)
				6000	OIS adj. MREF error
				7000	OIS adj. time out error
				8000	OIS adj. Yaw direction off set error
				9000	OIS adj. Pitch direction off set error
A000				OIS adj. Yaw direction gain error	
B000				OIS adj. Pitch direction gain error	
C000				OIS adj. Yaw direction position sensor error	
D000				OIS adj. Pitch direction position sensor error	
E000	OIS adj. other error				

Attribute	Main item	Sub item	Error code		Contents (Upper)		
			High 4 bits	Low 4 bits	Check point (Lower)		
HARD	VENUS A/D	Flash	28*0	0000	Flash charging error. IC6001-(279) signal line or Flash charging circuit		
				FLASH ROM (EEPROM Area)	FLASH ROM (EEPROM Area)	2B*0	0001
	0002	EEPROM write error IC6002 (FLASH ROM)					
	SYSTEM	RTC	2C*0				0001
	SOFT	CPU	Reset	30*0	0001	NMI reset	
0007					Non Mask-able Interrupt (30000001-30000007 are caused by factors)		
Card		Card	31*0	0001	0001	Card logic error SD memory card data line or IC6001 (VENUS 3)	
					0002	Card physical error SD memory card data line or IC6001 (VENUS 3)	
					0004	Write error SD memory card data line or IC6001 (VENUS 3)	
						Format error	
					CPU, ASIC hard	Stop	38*0
0002		Camera task invalid code error. IC6001 (VENUS 3)					
0100		File time out error in recording motion image IC6001 (VENUS 3)					
0200		File data send error in recording motion image IC6001 (VENUS 3)					
0300		Single or burst recording brake time out.					
Operation		Power on	3B*0	0000			
Zoom		Zoom	3C*0	0000	Inperfect zoom lens processing Zoom lens		
					35*0	0001	Software error (0-7bit : command, 8-15bit : status)
							0007
					35*1	0000	Though record preprocessing is necessary, it is not called.
35*2		0000	Though record preprocessing is necessary, it is not completed.				

About "*" indication in the above table:

The third digit from the left is different as follows.

- In case of 0 (example: 18001000)

When the third digit from the left shows "0", this error occurred under the condition of INITIAL SETTINGS has been completed.

It means that this error is occurred basically at user side.

- In case of 8 (example: 18801000)

When the third digit from the left shows "8", this error occurred under the condition of INITIAL SETTINGS has been released.

(Example; Factory assembling-line before unit shipment, Service mode etc.)

It means that this error is occurred at service side.

• 6. How to return to Normal Display:

Turn the power off and on, to exit from Error code display mode.







NOTE:

The error code can not be initialized.

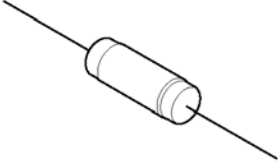
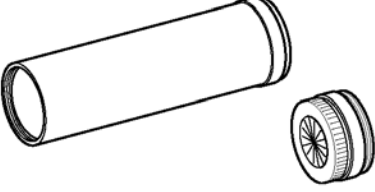
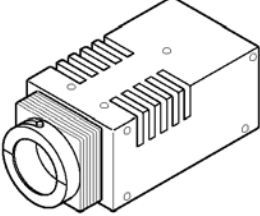
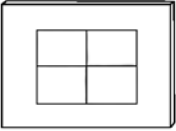
7 Service Fixture & Tools

7.1. Service Fixture and Tools

The following Service Fixture and tools are used for checking and servicing this unit.

Resistor for Discharging ERG5SJ102	Infinity Lens (with Focus Chart) VFK1164TCM02	LIGHT BOX VFK1164TDVLB
 An equivalent type of Resistor may be used.		 ※ with DC Cable
TR Chart RFKZ0443	Lens Cleaning Kit (BK) VFK1900BK	Grease (for lens) VFK1829
	 * Only supplied as 10 set/box.	
Furoyl grease (for focus motor) VFK1850	Driver (for mode dial installation screw) VFK1390	Dome type magnifying glass VFK1835
		

7.2. When Replacing the Main PCB

After replacing the MAIN PCB, be sure to achieve adjustment.

The adjustment instruction is available at "software download" on the "Support Information from NWBG/VDBG-PAVC" web-site in "TSN system", together with Maintenance software.

7.3. Service Position

This Service Position is used for checking and replacing parts. Use the following Extension cables for servicing.

Table S1 Extension Cable List

No.	Parts No.	Connection	Form
1	RFKZ0363	FP9001 (MAIN) - LCD UNIT	19PIN 0.5 FFC
2	VFK1974	FP9002 (MAIN) - LCD UNIT	4PIN 0.5 FFC
3	RFKZ0354	FP9801 (SUB) - CCD UNIT	37PIN 0.3 FFC
4	RFKZ0416	FP9802 (SUB) - LENS UNIT	41PIN 0.3 FFC
5	RFKZ0439	PP9001 (MAIN) - PS9801 (SUB)	100PIN B to B
6	VFK1541	PP9802 (SUB) - PS8001 (FLASH TOP)	40PIN B to B

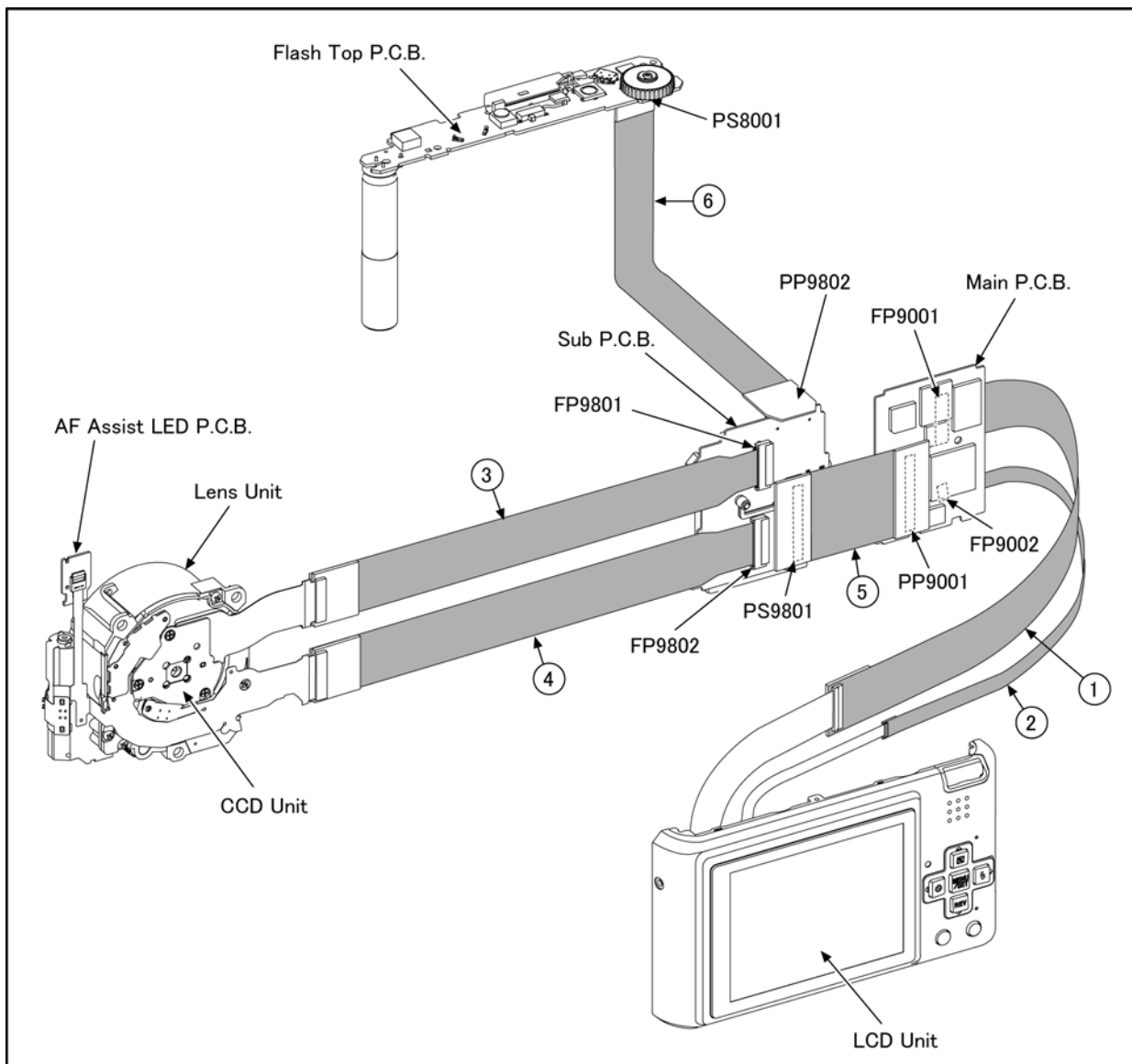

CAUTION-1. (When servicing FLASH TOP PCB)

1. Be sure to discharge the capacitor on FLASH TOP PCB.

Refer to "HOW TO DISCHARGE THE CAPACITOR ON FLASH TOP PCB".

The capacitor voltage is not lowered soon even if the AC Cord is unplugged or the battery is removed.

2. Be careful of the high voltage circuit on FLASH TOP PCB.
3. DO NOT allow other parts to touch the high voltage circuit on FLASH TOP PCB.

8 Disassembly and Assembly Instructions

8.1. Disassembly Flow Chart

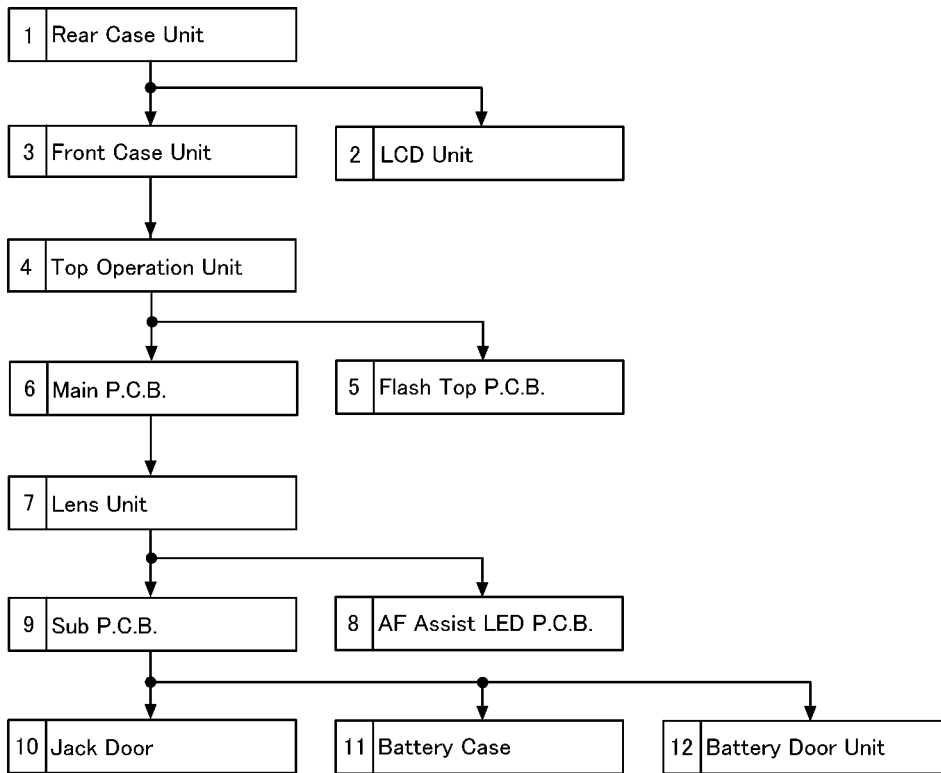

8.2. PCB Location

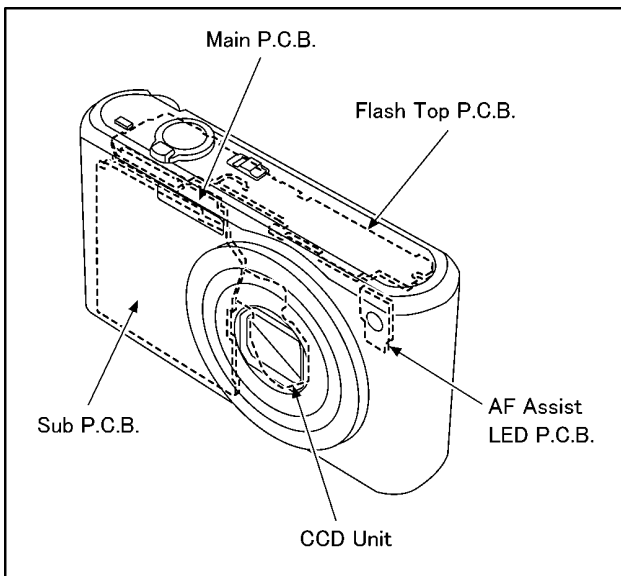

8.3. Disassembly Procedure

8.3.1. Removal of the Rear Case Unit

No.	Item	Fig	Removal
1	Rear Case Unit	Fig. D1	Card
			Battery
			1 Screw (A)
			3 Screws (B)
			FP9001(Flex)
			FP9002(Flex)
			Rear Case Unit
2	LCD Unit	Fig. D2	2 Locking tabs
			LCD Unit
3	Front Case Unit	Fig. D3	1 Screw (C)
			4 Screws (D)
			Front Case Unit
4	Top Operation Unit	Fig. D4	PS8001(Connector)
			Top Operation Unit
5	Flash Top P.C.B.	Fig. D5	2 Screws (E)
			2 Locking tabs
		Fig. D6	Top Ornament Unit
			Power knob
			4 Locking tabs
			Flash Cover
		Speaker	
Fig. D7	Flash Top P.C.B.		
Fig. D8	NOTE (When Assembling)		
6	Main P.C.B.	Fig. D9	PP9001(Connector)
			Main P.C.B.
7	Lens Unit	Fig. D10	3 Screws (F)
			1 Screw (G)
			Frame Plate
			Tripod Fixing Plate
		Fig. D11	FP9801(Flex)
			FP9802(Flex)
			1 Locking tab
Lens Unit			
8	AF Assist LED P.C.B.	Fig. D12	FP9901(Flex)
			AF Assist LED P.C.B.
9	Sub P.C.B.	Fig. D13	1 Screw (H)
			PCB Spacer
			Sub P.C.B.
10	Jack Door	Fig. D14	Strap Holder
			Jack Door Shaft
			Jack Door
11	Battery Case	Fig. D15	Battery Out Spring
			AF Panel Light
			PCB Plate
			Battery Case
			Battery Door Unit
12	Battery Door Unit	Fig. D16	Battery Door Shaft
			Battery Door Spring
			Battery Door Unit

NOTE:

When servicing and reassembling, remove the card and battery from the unit.

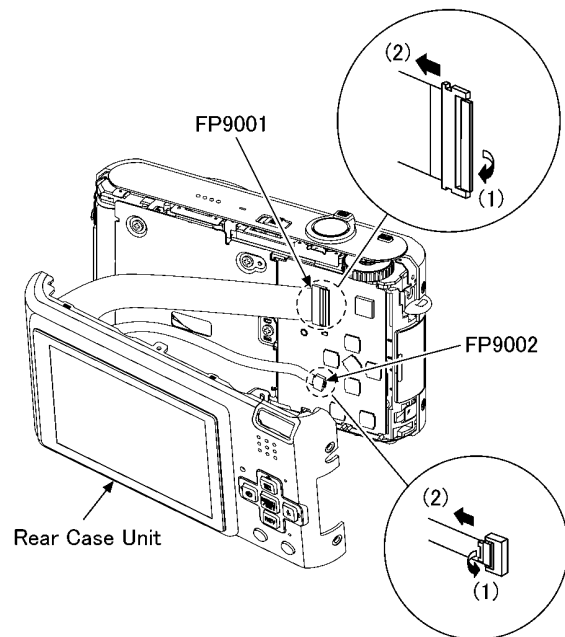
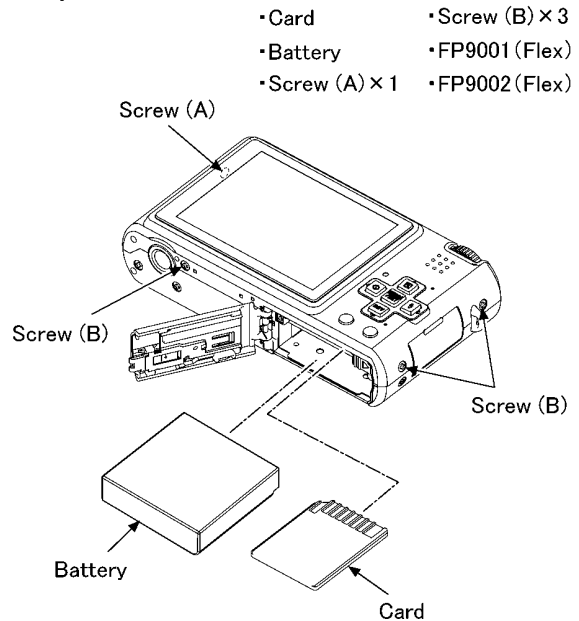

NOTE: (When Disassembling)

When remove the flex, pull up the locking tab in the direction of arrow (1), and then remove the flex in the direction of arrow (2).

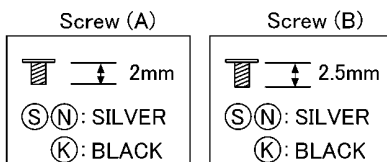

Fig. D1

8.3.2. Removal of the LCD Unit

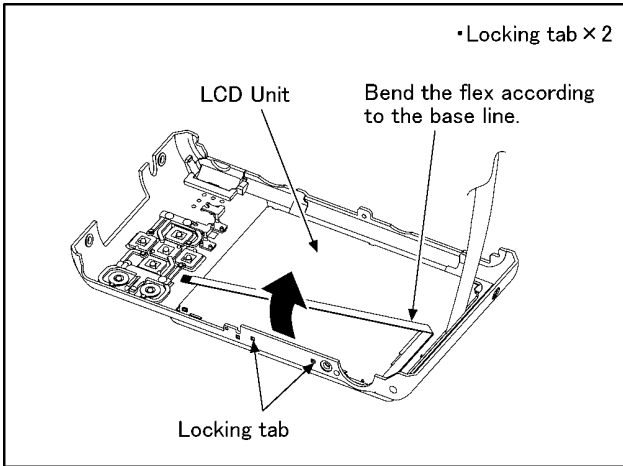

Fig. D2

8.3.3. Removal of the Front Case Unit

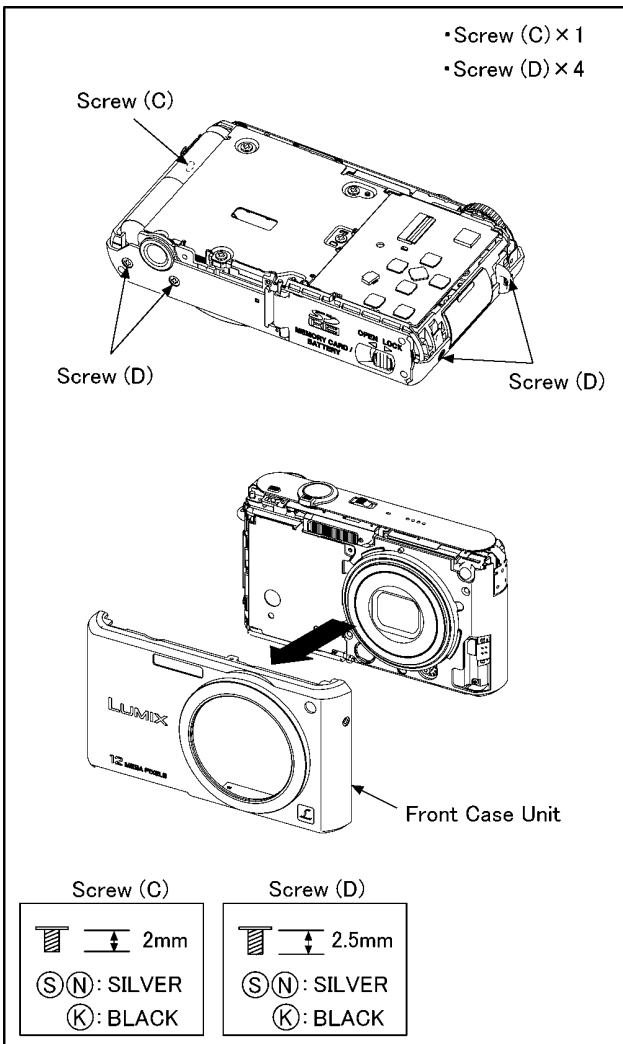

Fig. D3

8.3.4. Removal of the Top Operation Unit

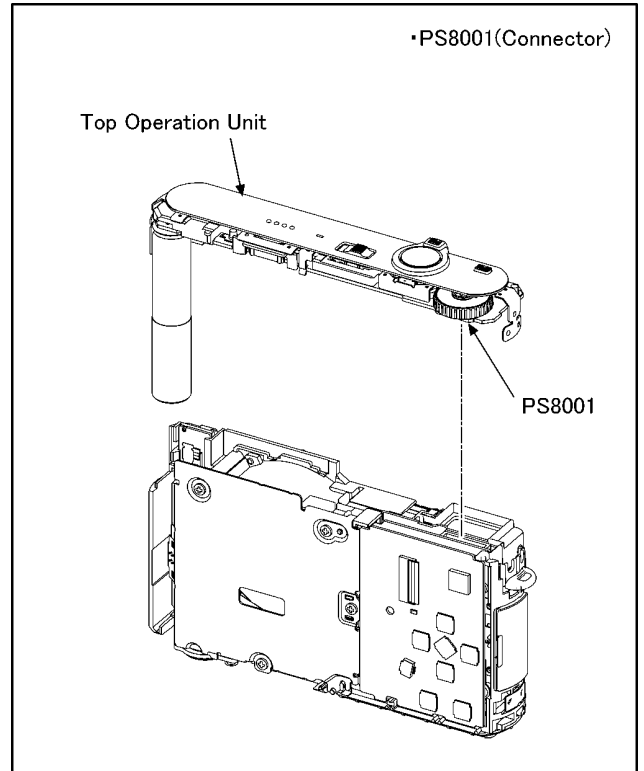

Fig. D4

8.3.5. Removal of the Flash Top P.C.B.

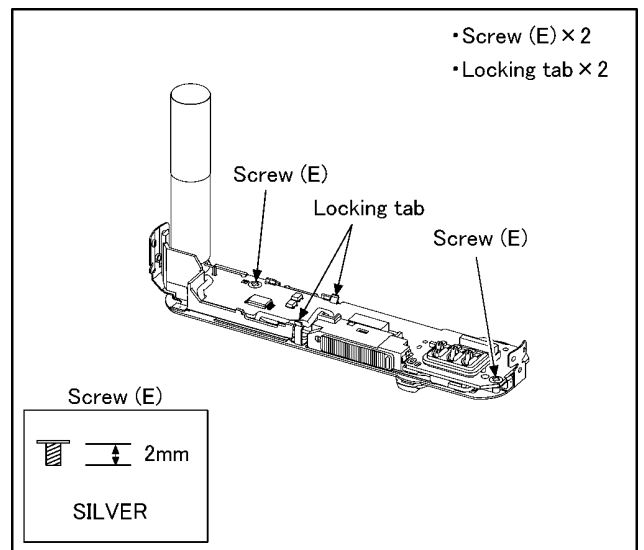

Fig. D5

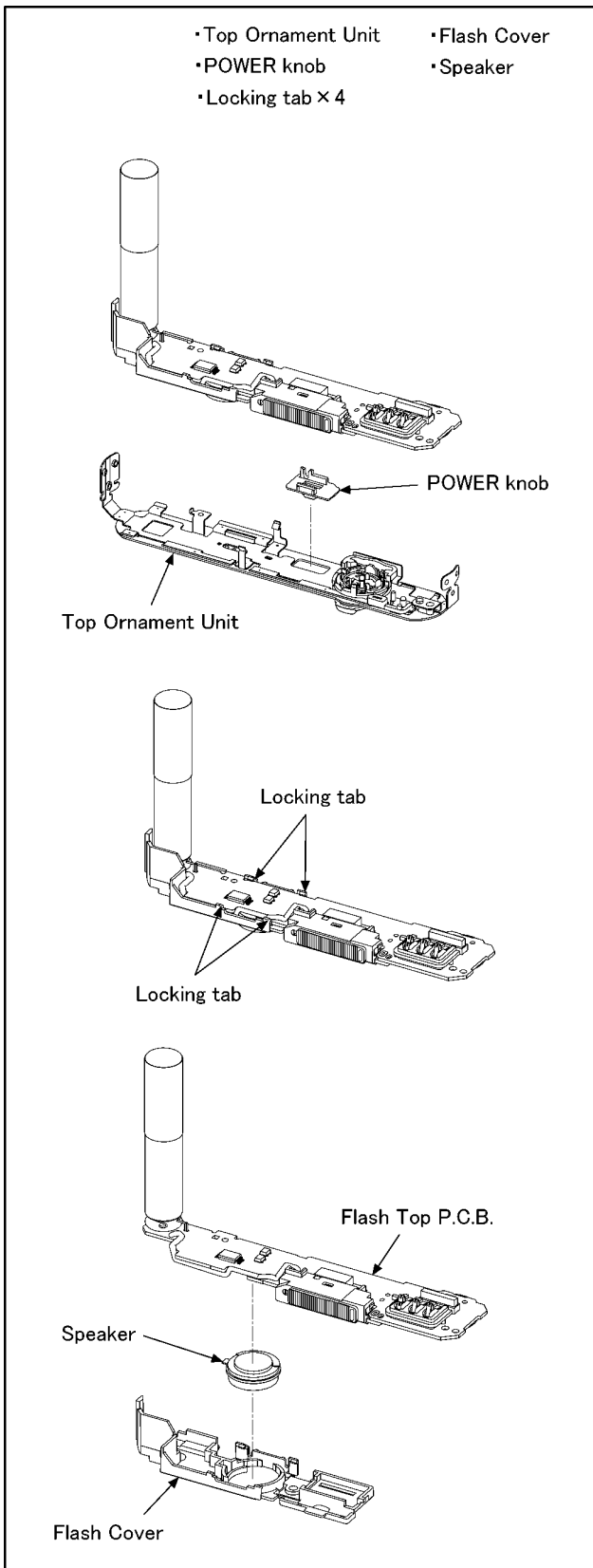

Fig. D6

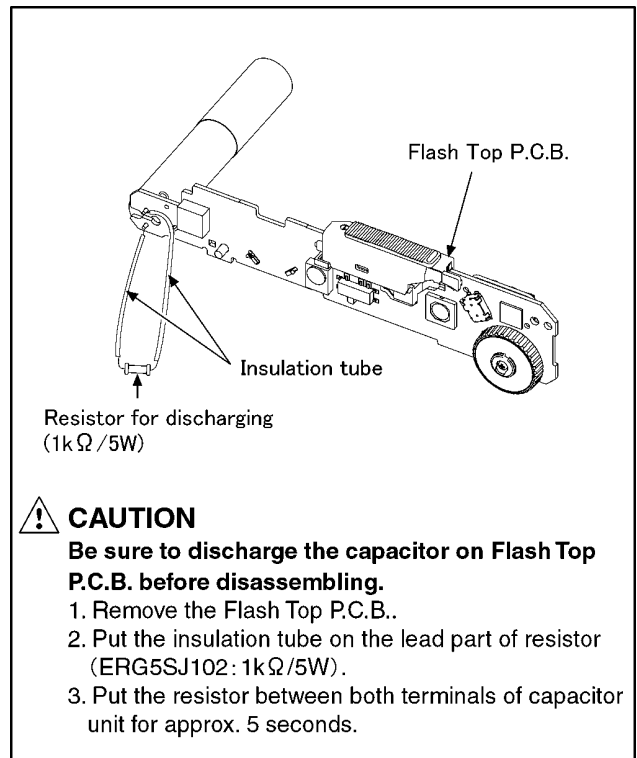

Fig. D7

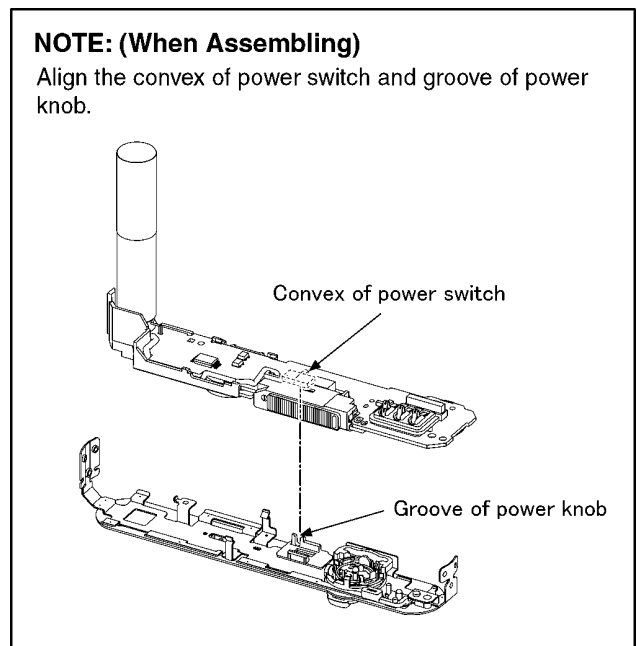

Fig. D8

8.3.6. Removal of the Main P.C.B.

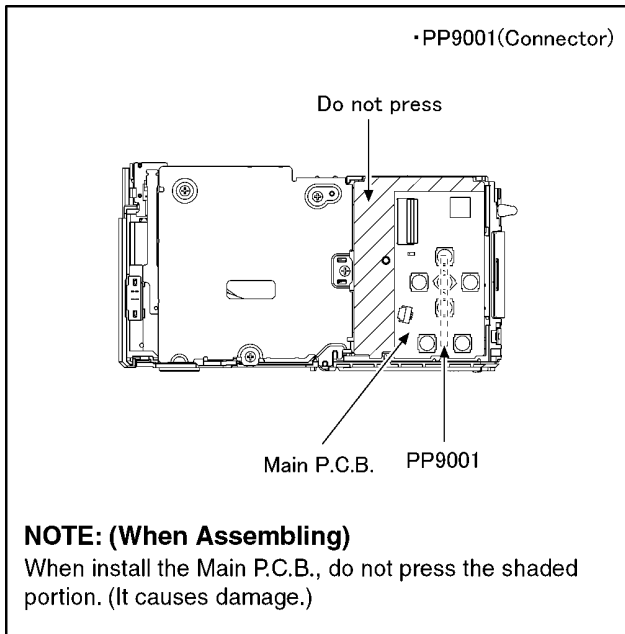

Fig. D9

8.3.7. Removal of the Lens Unit

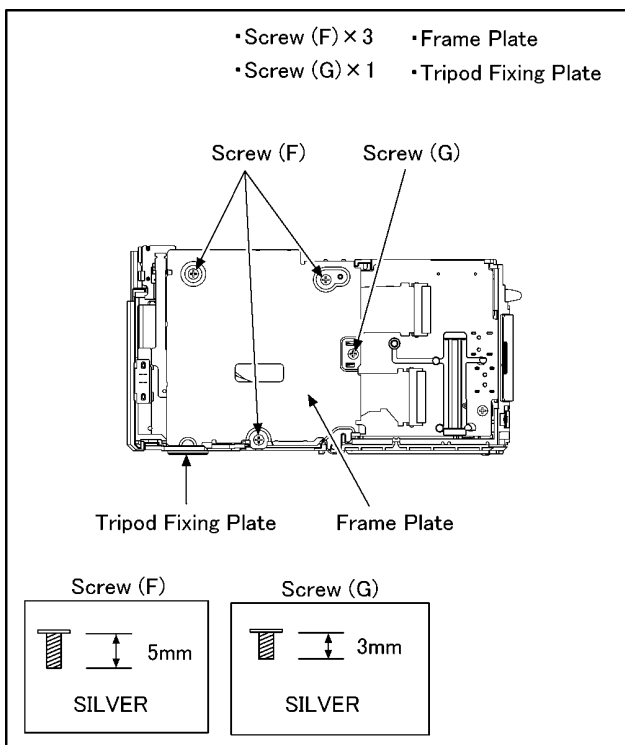

Fig. D10

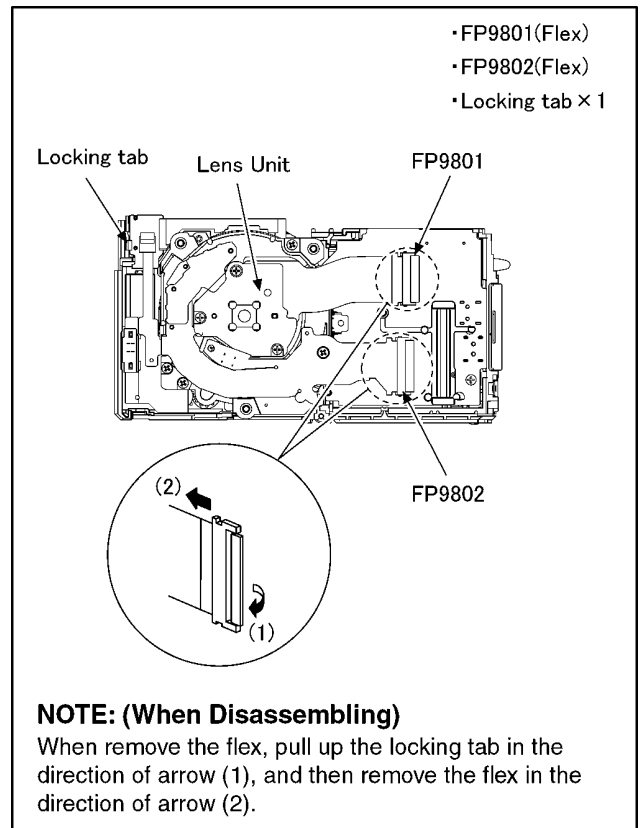

Fig. D11

8.3.8. Removal of the AF Assist LED P.C.B.

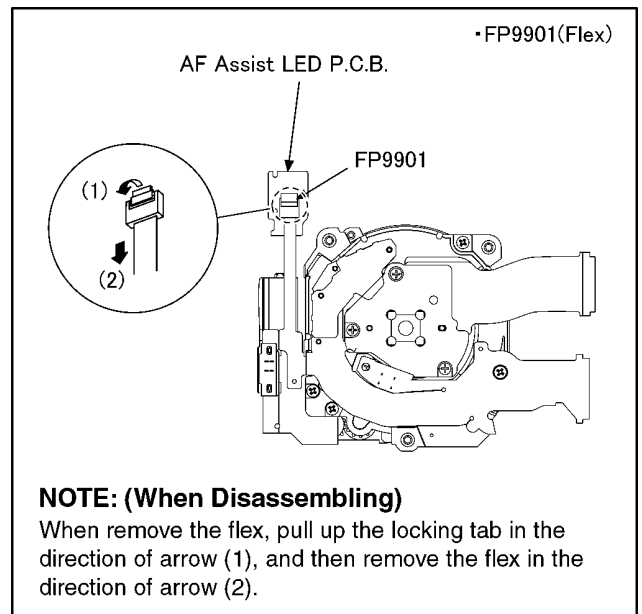

Fig. D12

8.3.9. Removal of the Sub P.C.B.

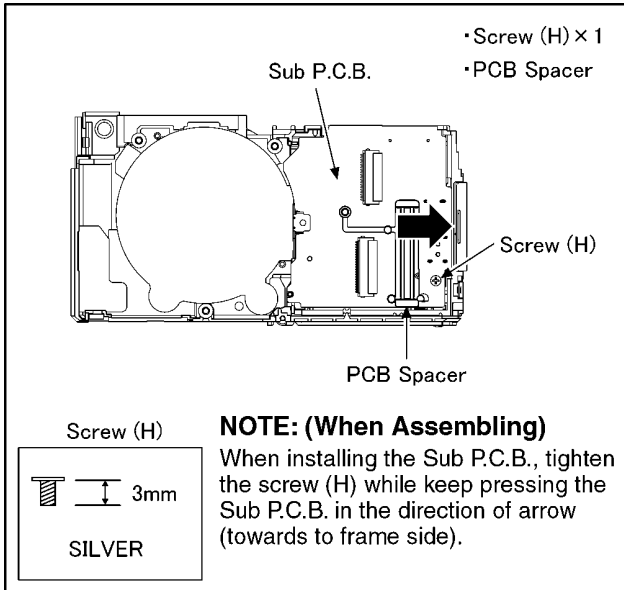

Fig. D13

8.3.10. Removal of the Jack Door

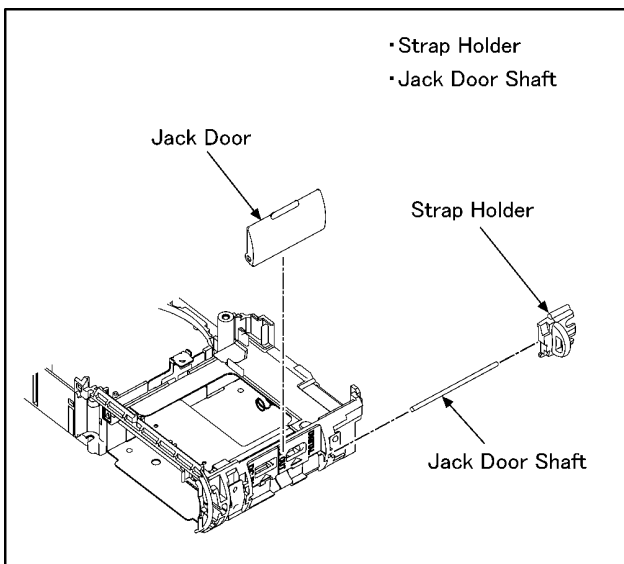

Fig. D14

8.3.11. Removal of the Battery Case

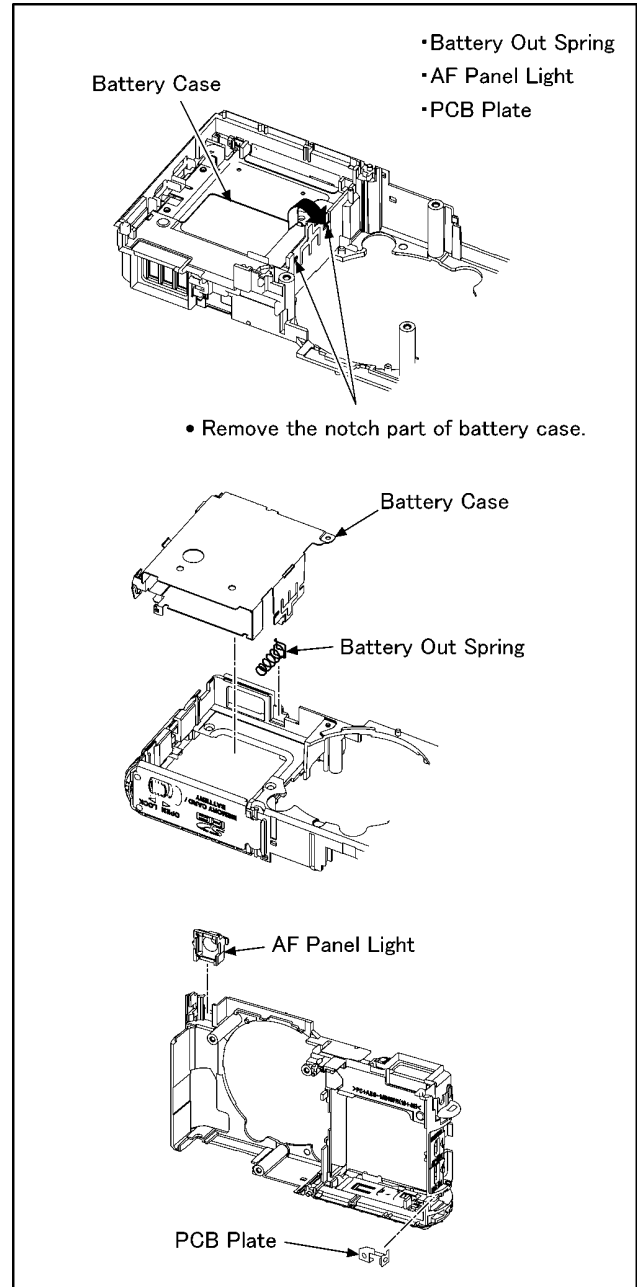

Fig. D15

8.3.12. Removal of the Battery Door Unit

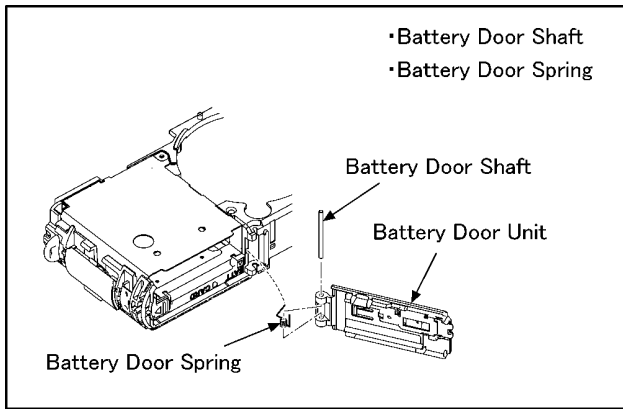

Fig. D16

NOTE: (When Assembling)

Be sure to confirm the following points when assembling.

- The Screw is tightened enough.
- Assembling conditions are fine. (No distortion, no illegal-space.)
- No dust and/or dirt on every Lens surfaces.
- LCD image is fine. (No dust and dirt on it, and no gradient images.)

8.4. Disassembly Procedure for the Lens

NOTE: When Disassembling and Assembling for the Lens

1. To minimize the possibility of the CCD being dirt, perform disassemble and/or assemble under the condition of the CCD is being mounted.
Disassembling procedures for the CCD unit, refer to item 8.6.
2. Take care that the dust and dirt are not entered into the lens.
In case of the dust is putted on the lens, blow off them by airbrush.
3. Do not touch the surface of lens.
4. Use lens cleaning KIT (BK)(VFK1900BK).
5. Apply the grease (VFK1829) to the point where is shown to "Grease apply" in the figure.
When the grease is applied, use a toothpick and apply thinly.

8.4.1. Zoom Motor Unit, Master Frange Unit, Direct/Drive Frame Unit and 1st Lens Frame/2nd Lens Frame Move Unit

1. Unscrew the 4 screws (A).
2. Remove the zoom motor unit to the indicated by arrow.
3. Move the master frange unit to the indicated by arrow.

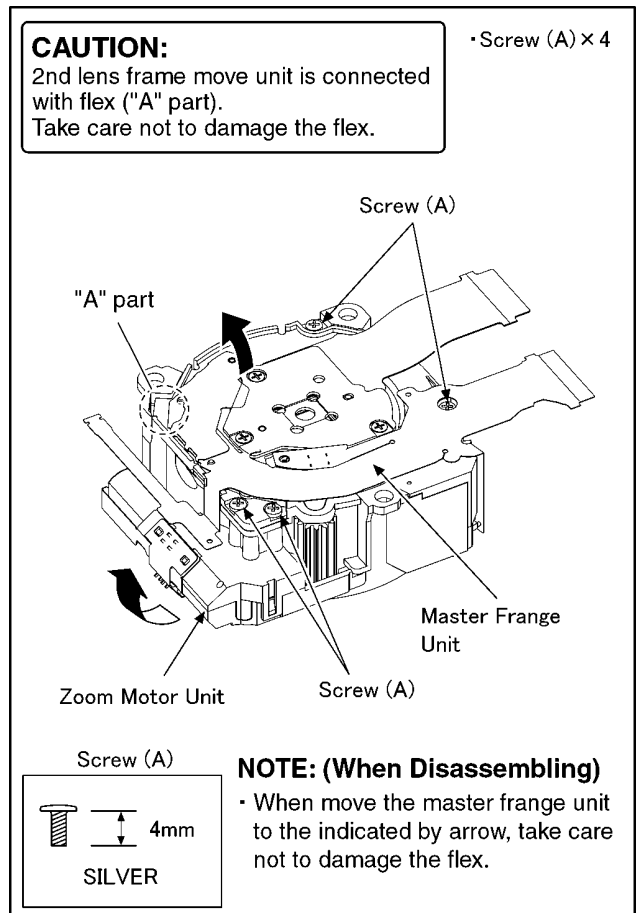

4. Turn the drive gear to the indicated by arrow fully.

NOTE: (When Disassembling)

- Take care not to damage the flex.

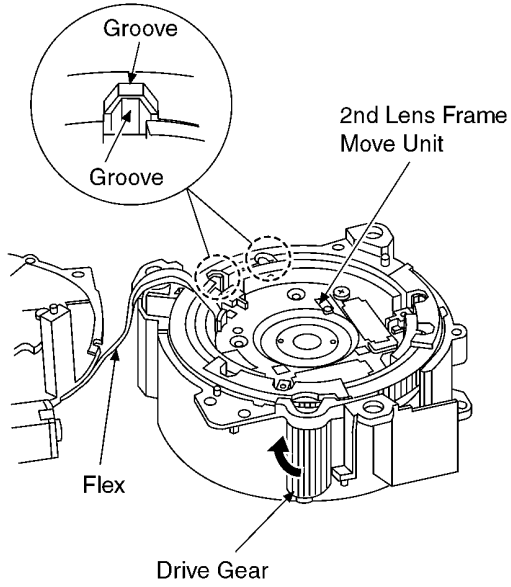

5. Push the drive unit to the indicated by arrow from lens side, and then remove the unit of drive/direct frame unit, 1st lens frame/2nd lens frame move unit from the fixed frame unit.

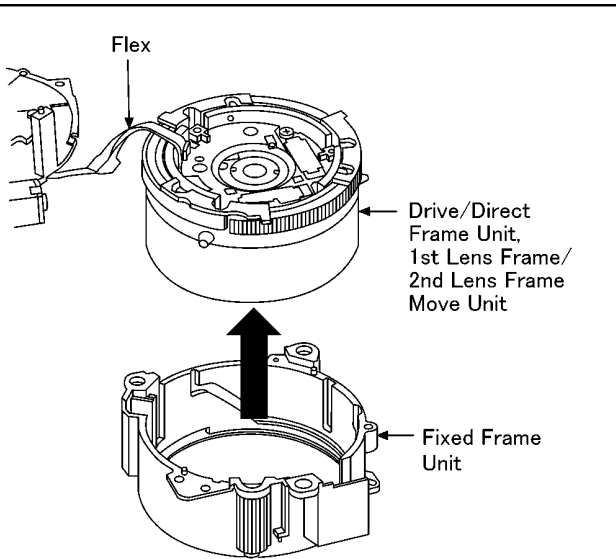

NOTE: (When Disassembling)

- Take care not to damage the flex.
- When lift the drive/direct frame unit, 1st lens frame/2nd lens frame move unit, Take care not to put fingerprint of the lens.

6. Push the 1st lens frame unit to the indicated by arrow from lens side, and then remove the unit of 1st lens frame/2nd lens frame move unit from the drive/direct frame unit.

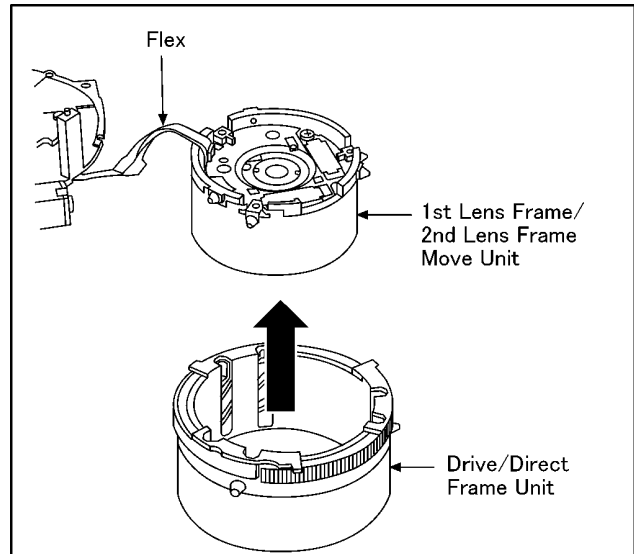

NOTE: (When Disassembling)

- Take care not to damage the flex.
- When lift the 1st lens frame/2nd lens frame move unit, Take care not to put fingerprint of the lens.

8.4.2. Removal of the Direct Frame

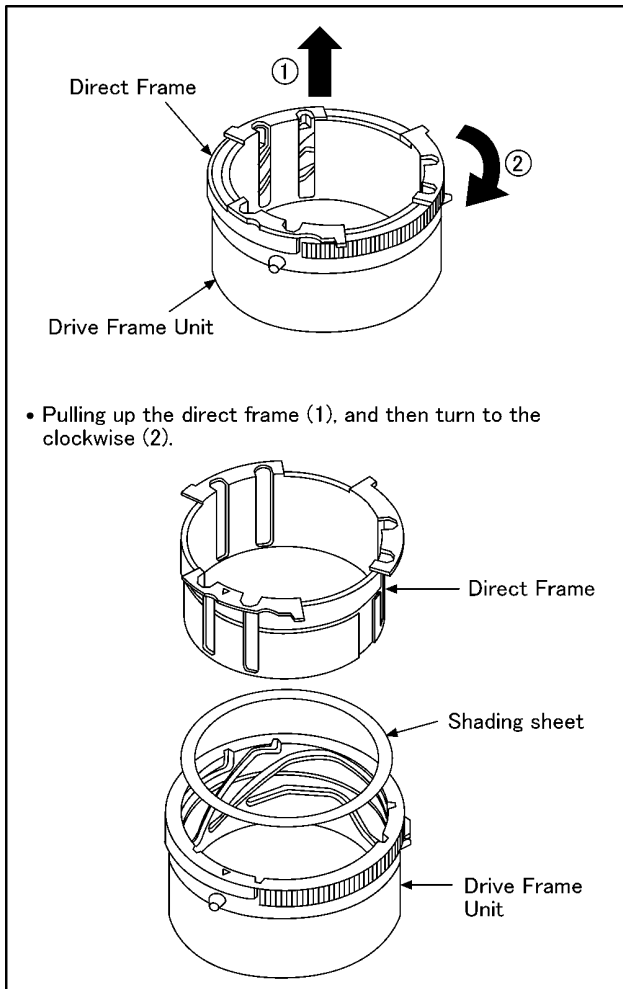

8.4.3. Removal of the 2nd Lens Frame Move Unit

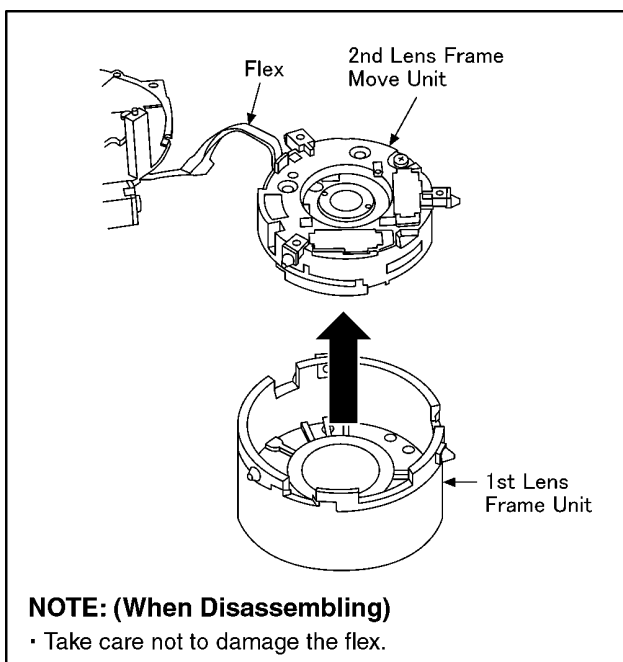

8.5. Assembly Procedure for the Lens

8.5.1. Phase alignment of the Direct Frame and Drive Frame Unit

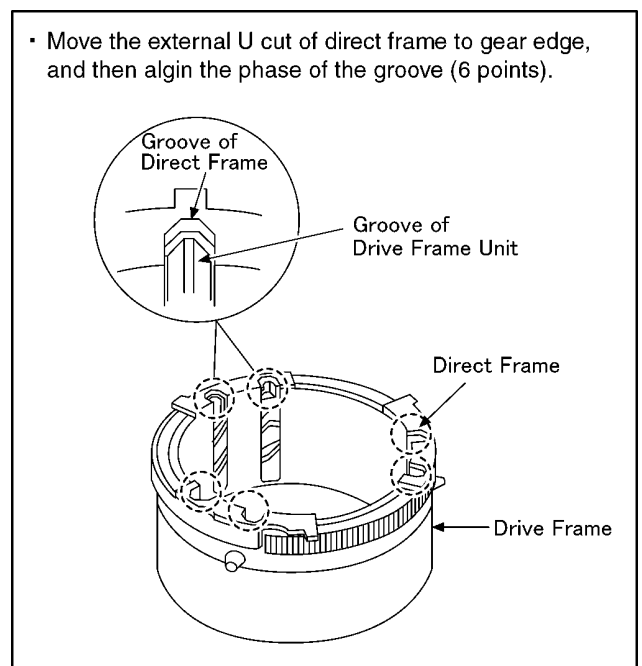
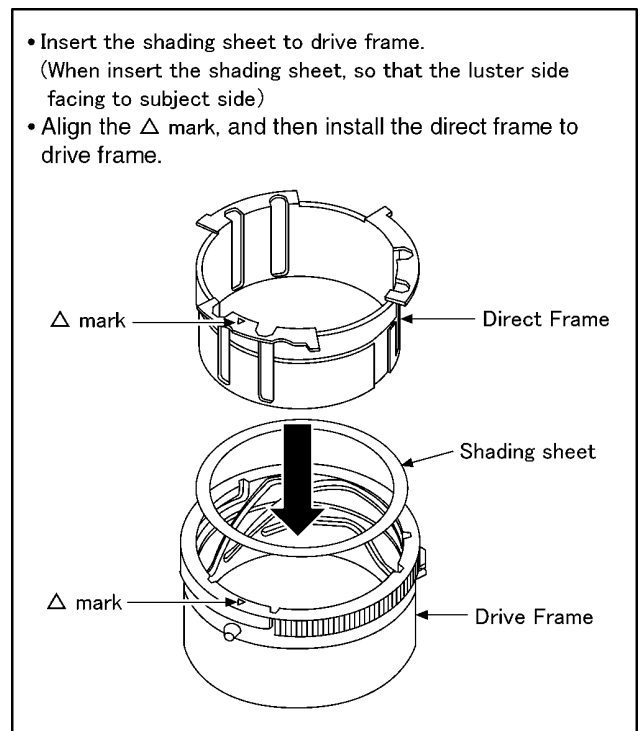

8.5.2. Phase alignment of the Drive/Direct Unit and Fixed Frame

- Align the Δ mark, and then install the drive/direct frame unit to fixed frame unit.

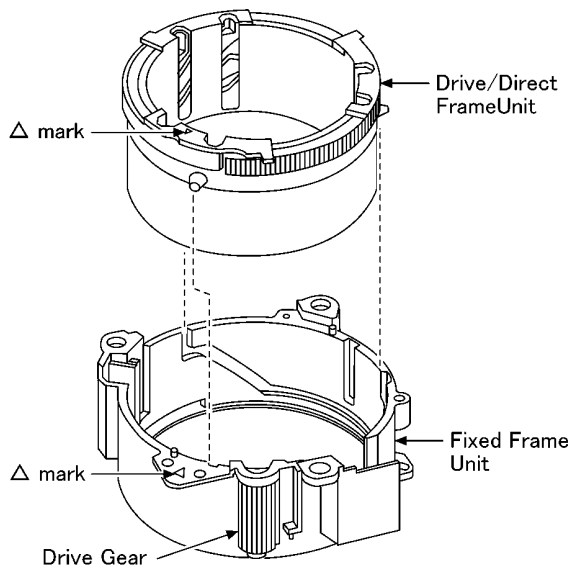

NOTE: (When Assembling)

- With aligning the phase of the drive/direct frame unit, confirm the gear of drive unit is engaged with the fixed frame unit firmly.

8.5.3. Assembly for the 1st Lens Frame Unit

- Align the Δ mark, and then install the 1st lens frame unit to fixed frame unit.

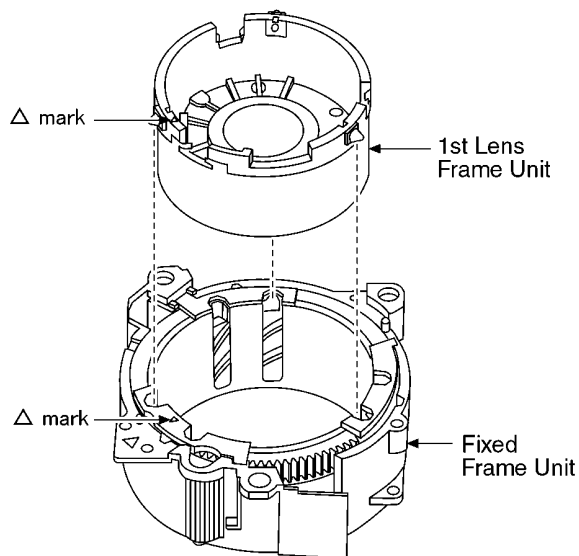

FRONT VIEW

- Install the 1st lens frame unit so that the "LEICA" character may become the position of the figure below.

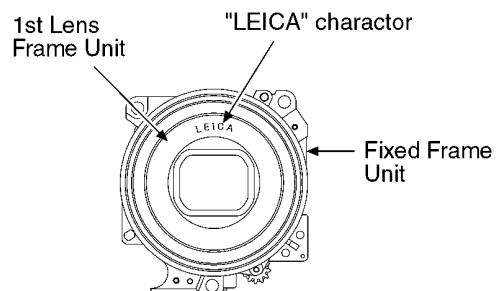

8.5.4. Assembly for the Zoom Motor Unit, Master Frange Unit and 2nd Lens Frame Move Unit

- Align the flex and insert part of flex, and then insert 2nd Lens Frame Move Unit and Master Frange Unit to Fixed Frame Unit.

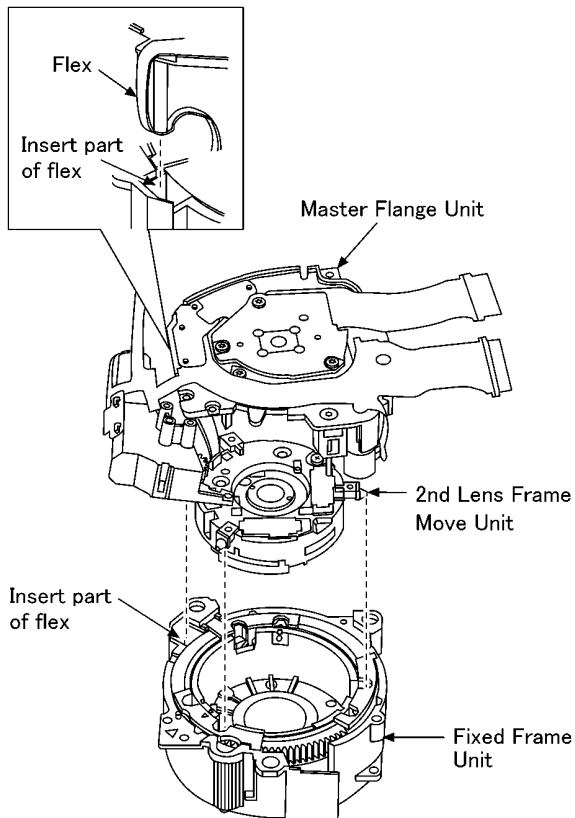

NOTE: (When Assembling)

- When insert the 2nd lens frame move unit to fixed frame unit, push it until click sound is heard.
- Take care not to damage the flex.
- Refer to "THE APPLYMENT OF GREASE METHOD" when installing the master frange unit.

- Turn the Drive Gear in the direction of an arrow, and then confirm the lens shutter is closed.

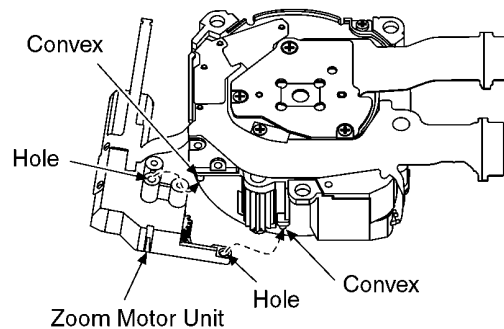
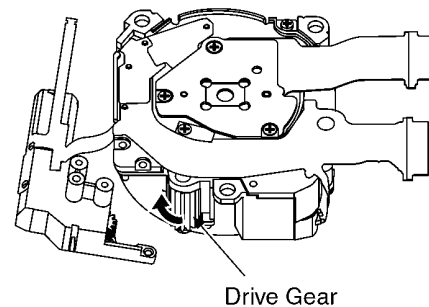
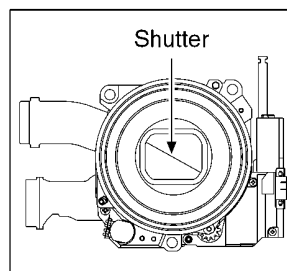

NOTE: (When Assembling)

- Align the convex of fixed frame unit and hole of zoom motor unit, and then install them.

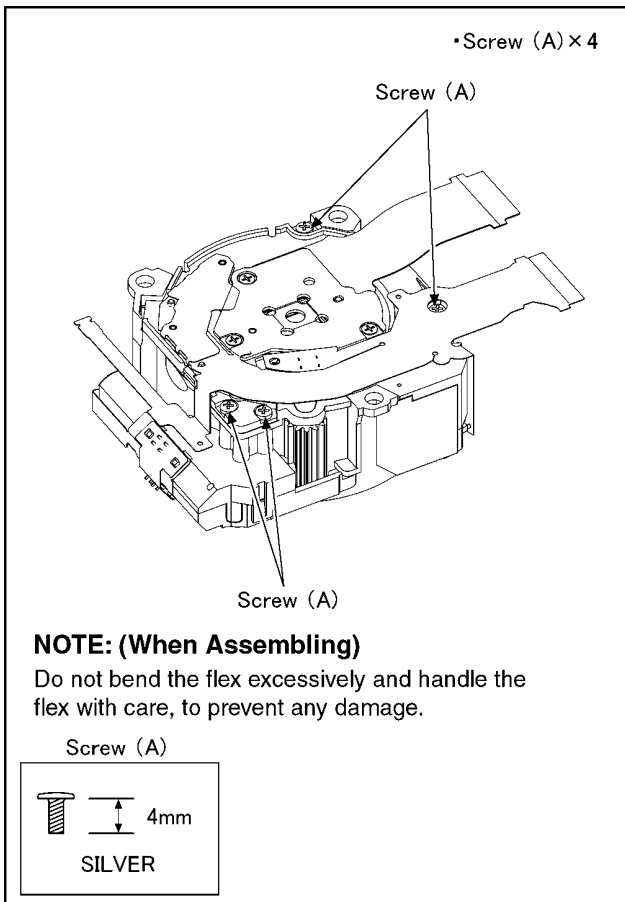

8.6. Removal of the CCD Unit

To prevent the CCD unit from catching the dust and dirt, do not remove the CCD unit except for replacing.

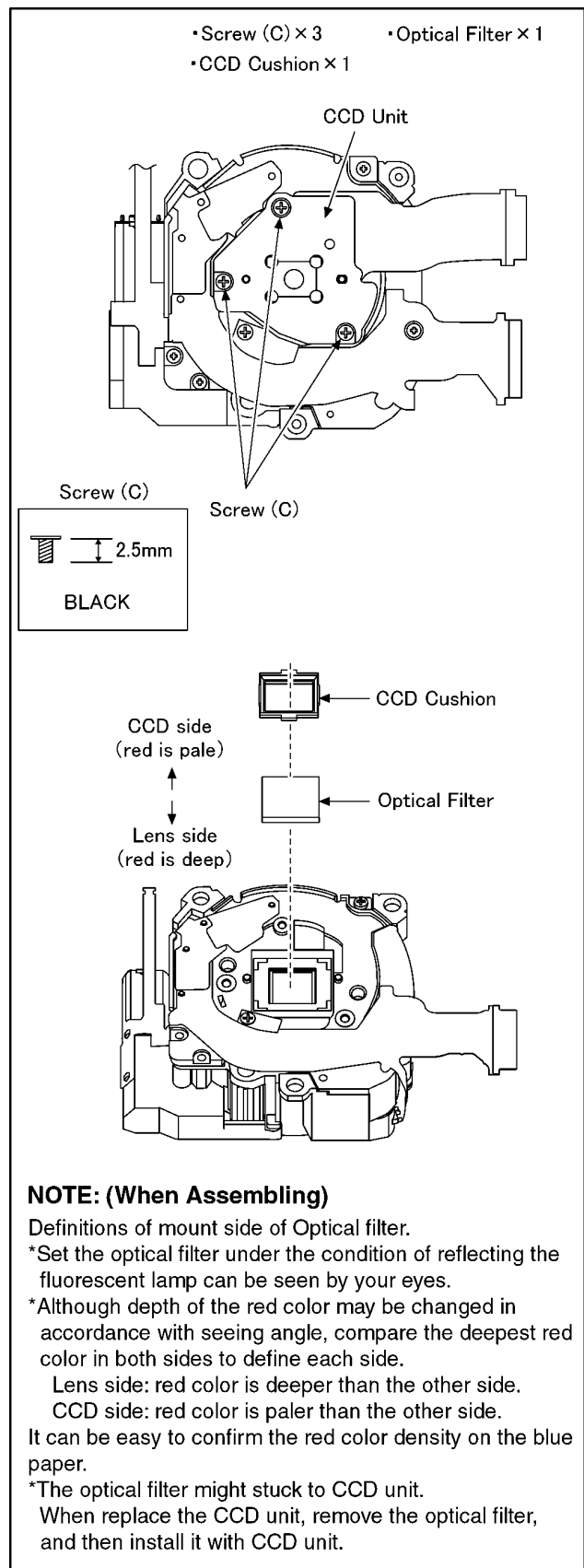

8.7. The Applyment of Grease Method

The grease apply point of lens unit are as follows.

Apply grease additionally in the specified position if necessary.

When the grease is applied, use a toothpick and apply thinly.

- Lead screw
 - Grease: VFK1850 (Furoyl type)
 - Amount of apply: 2 - 4 mg
- Guide pole
 - Grease: VFK1829
 - Amount of apply: 2 - 4 mg

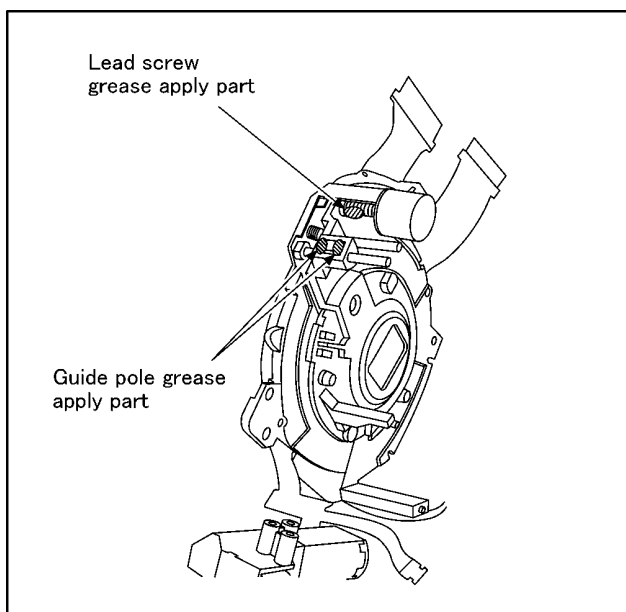

9 Measurements and Adjustments

9.1. Matrix Chart for Replaced Part and Necessary Adjustment

The relation between Replaced part and Necessary Adjustment is shown in the following table.

When concerned part is replaced, be sure to achieve the necessary adjustment(s).

As for Adjustment condition/procedure, consult the "Adjustment Manual" which is available in Adjustment software.

The Adjustment software is available at "TSN Website", therefore, access to "TSN Website" at "Support Information from NWBG/VDBG-PAVC".

NOTE:

After adjustments have been terminated, make sure to achieve "INITIAL SETTINGS".

Adjustment Item		Replaced Part				
		Main P.C.B.	VENUS (IC6001)	Flash-ROM (IC6002)	Lens Part (Excluding CCD)	CCD Unit
Camera Section	OIS hall element adjustment (OIS)	○	○	○	○	
	Back focus adjustment (BF)	○	○	○	○	
	Shutter adjustment (SHT)	○	○	○	○	○
	ISO sensitivity adjustment (ISO)	○	○	○	○	○
	AWB adjustment High brightness coloration inspection (WBL)	○	○	○	○	○
	CCD white scratch compensation (WKI)	○	○	○		○

NOTE:

*There is no LCD adjustment in this model.

*There is no CCD Black scratch compensation adjustment (BKI) in this model.

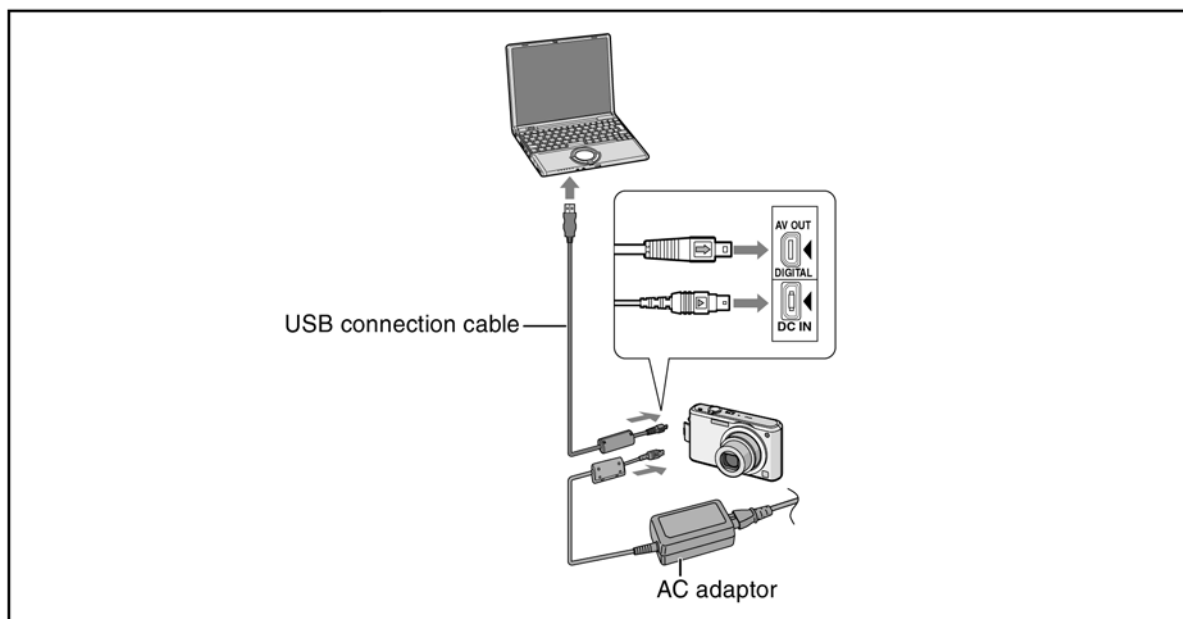

10 Maintenance

10.1. Cleaning Lens and LCD Panel

Do not touch the surface of lens and LCD Panel with your hand.

When cleaning the lens, use air-Blower to blow off the dust.

When cleaning the LCD Panel, dampen the lens cleaning paper with lens cleaner, and the gently wipe the their surface.

Note:

The Lens Cleaning KIT ; VFK1900BK (Only supplied as 10 set/Box) is available as Service Aid.

Service Manual

Diagrams and Replacement Parts List

Digital Camera

Model No.

DMC-FX100P	DMC-FX100E
DMC-FX100PC	DMC-FX100GC
DMC-FX100PL	DMC-FX100GD
DMC-FX100EB	DMC-FX100GK
DMC-FX100EE	DMC-FX100GN
DMC-FX100EF	DMC-FX100GT
DMC-FX100EG	DMC-FX100SG

Vol. 1
 Colour
 (S).....Silver Type
 (K).....Black Type
 (N).....Gold Type

Table of contents

S1. About Indication of The Schematic Diagram.....	S-1	S5.3. CCD Flex P.C.B.....	S-9
S1.1. Important Safety Notice.....	S-1	S5.4. Lens Flex P.C.B.....	S-10
S2. Voltage Chart	S-2	S6. Replacement Parts List.....	S-11
S2.1. Flash Top P.C.B.....	S-2	S7. Exploded View	S-18
S3. Block Diagram.....	S-3	S7.1. Frame and Casing Section.....	S-18
S3.1. Overall Block Diagram	S-3	S7.2. Packing Parts and Accessories Section (1)	S-19
S4. Schematic Diagram.....	S-4	S7.3. Packing Parts and Accessories Section (2)	S-20
S4.1. Interconnection Diagram	S-4		
S4.2. Flash Top Schematic Diagram	S-5		
S4.3. AF Assist LED Schematic Diagram	S-6		
S4.4. CCD Flex Schematic Diagram	S-6		
S4.5. Lens Flex Schematic Diagram	S-7		
S5. Print Circuit Board	S-8		
S5.1. Flash Top P.C.B.....	S-8		
S5.2. AF Assist LED P.C.B.	S-9		

S1. About Indication of The Schematic Diagram

S1.1. Important Safety Notice

COMPONENTS IDENTIFIED WITH THE MARK \triangle HAVE THE SPECIAL CHARACTERISTICS FOR SAFETY. WHEN REPLACING ANY OF THESE COMPONENTS USE ONLY THE SAME TYPE.

1. Although reference number of the parts is indicated on the P.C.B. drawing and/or schematic diagrams, it is NOT mounted on the P.C.B. when it is displayed with "\$" mark.
2. It is only the "Test Round" and no terminal (Pin) is available on the P.C.B. when the TP (Test Point) indicated as "●" mark.
3. The voltage being indicated on the schematic diagram is measured in "Standard-Playback" mode when there is no specify mode is mentioned.
4. Although the voltage and waveform available on here is measured with standard frame, it may be differ from actual measurement due to modification of circuit and so on.
5. The voltage being indicated here may be include observational-error (deviation) due to internal-resistance and/or reactance of equipment. Therefore, handle the value indicated on here as reference.
6. Use the parts number indicated on the Replacement Parts List .
7. Indication on Schematic diagrams:

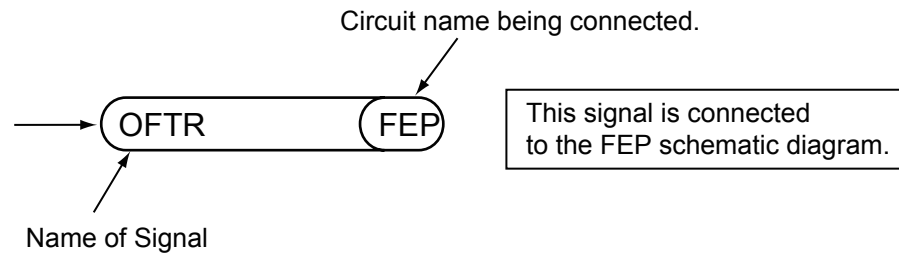

S2. Voltage Chart

Note) Indicated voltage values are the standard values for the unit measured by the DC electronic circuit tester (high-impedance) with the chassis taken as standard.
Therefore, there may exist some errors in the voltage values, depending on the internal impedance of the DC circuit tester.

S2.1. Flash Top P.C.B.

REF No.	PIN No.	POWER ON
IC8001	1	0
IC8001	2	0
IC8001	3	6.9
IC8001	4	0
IC8001	5	0
Q8009	1	5.7
Q8009	2	5.7
Q8009	3	0
Q8009	4	0
Q8009	5	5.7
Q8009	6	5.7

S3. Block Diagram

S3.1. Overall Block Diagram

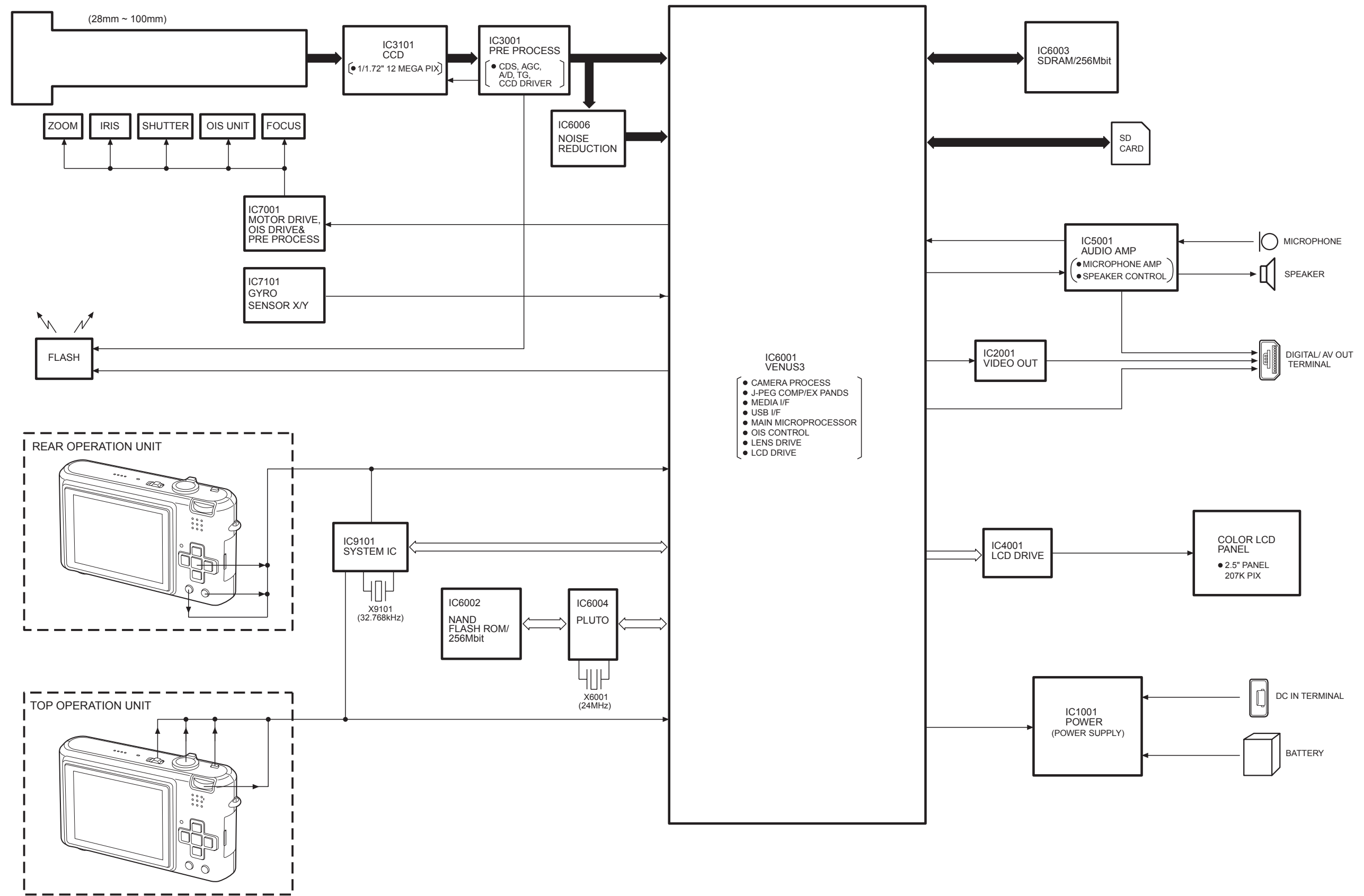

DMC-FX100 OVERALL BLOCK DIAGRAM

S4. Schematic Diagram

S4.1. Interconnection Diagram

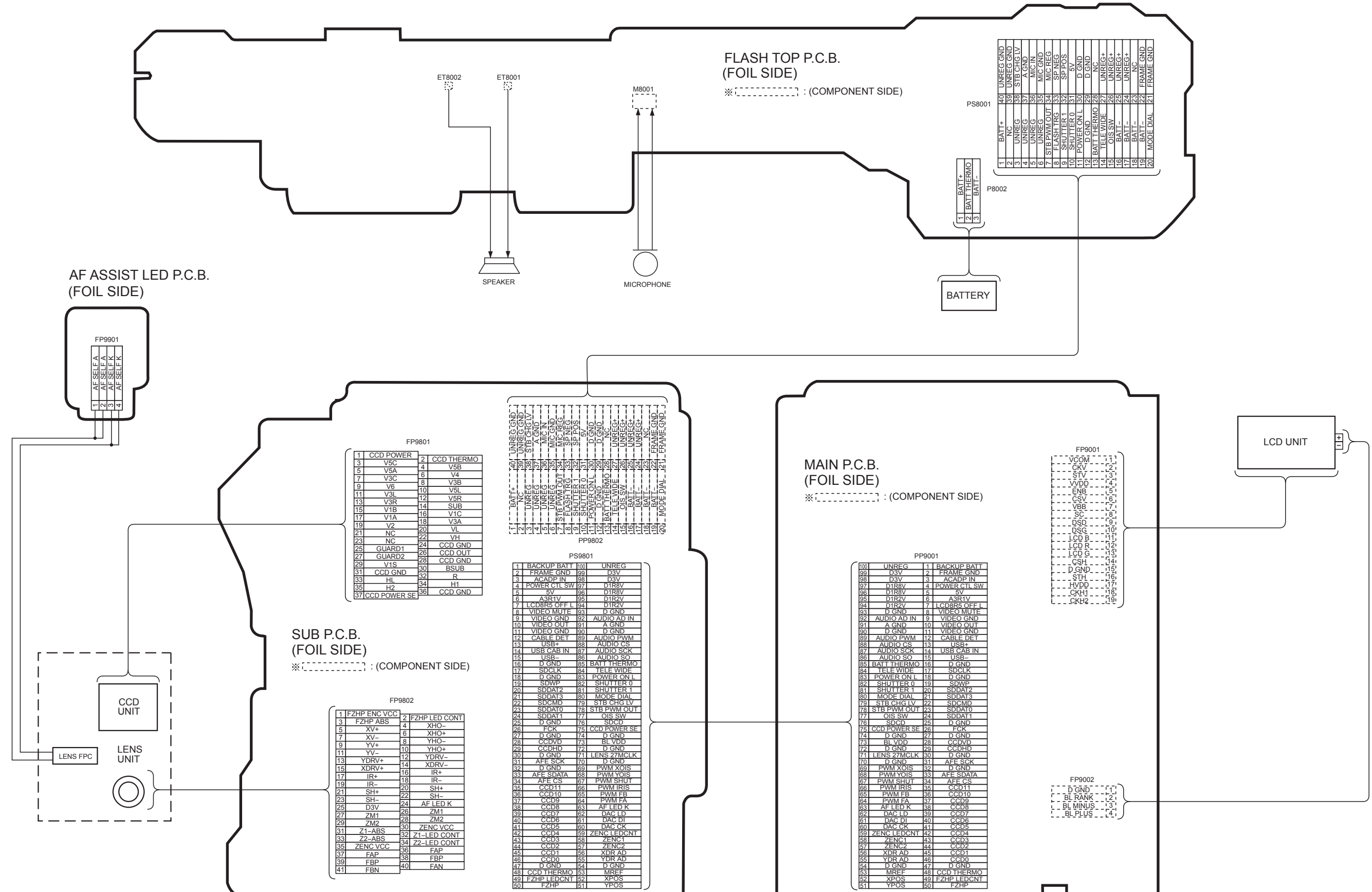

S4.2. Flash Top Schematic Diagram

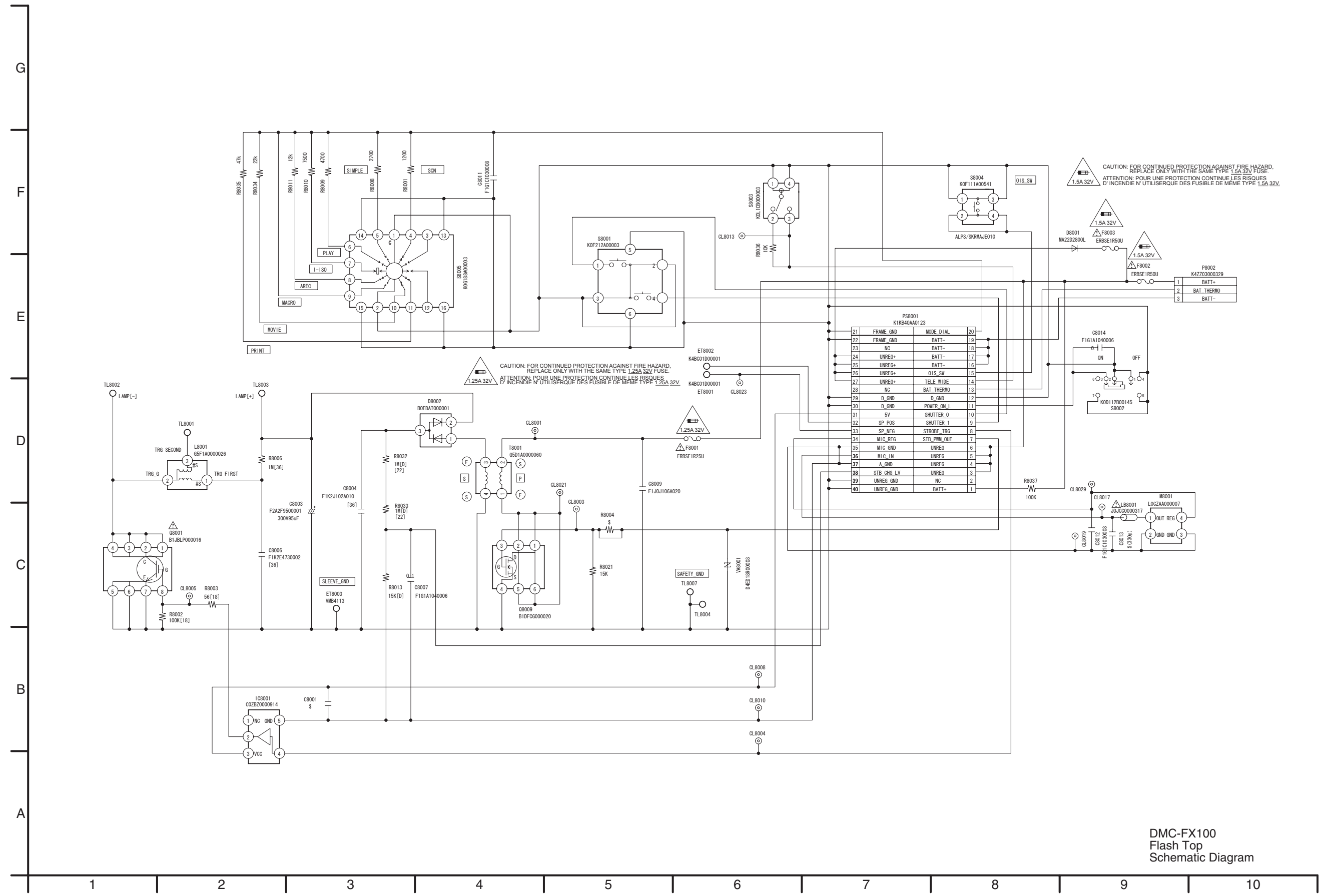

S4.3. AF Assist LED Schematic Diagram / S4.4. CCD Flex Schematic Diagram

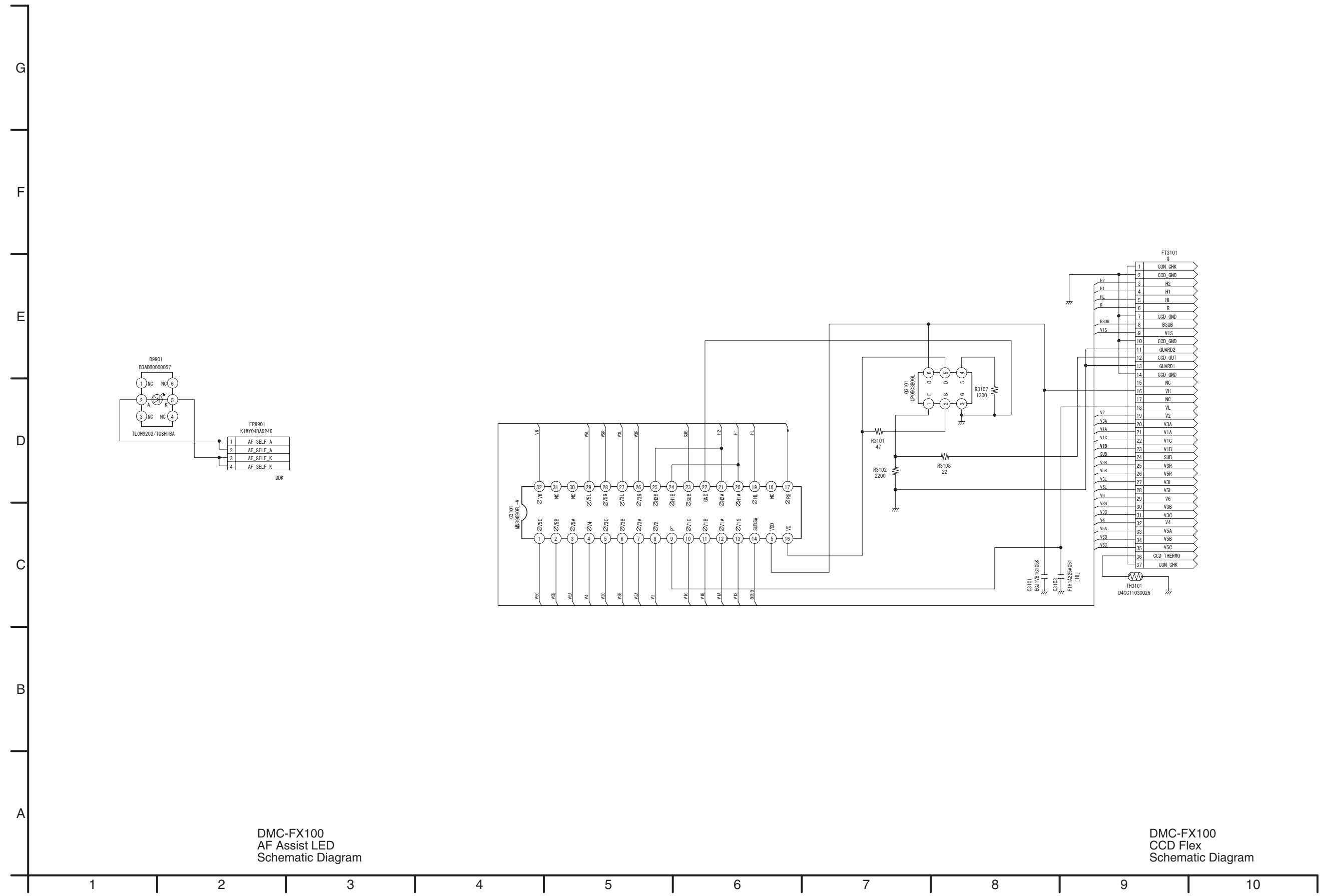

DMC-FX100
AF Assist LED
Schematic Diagram

DMC-FX100
CCD Flex
Schematic Diagram

S4.5. Lens Flex Schematic Diagram

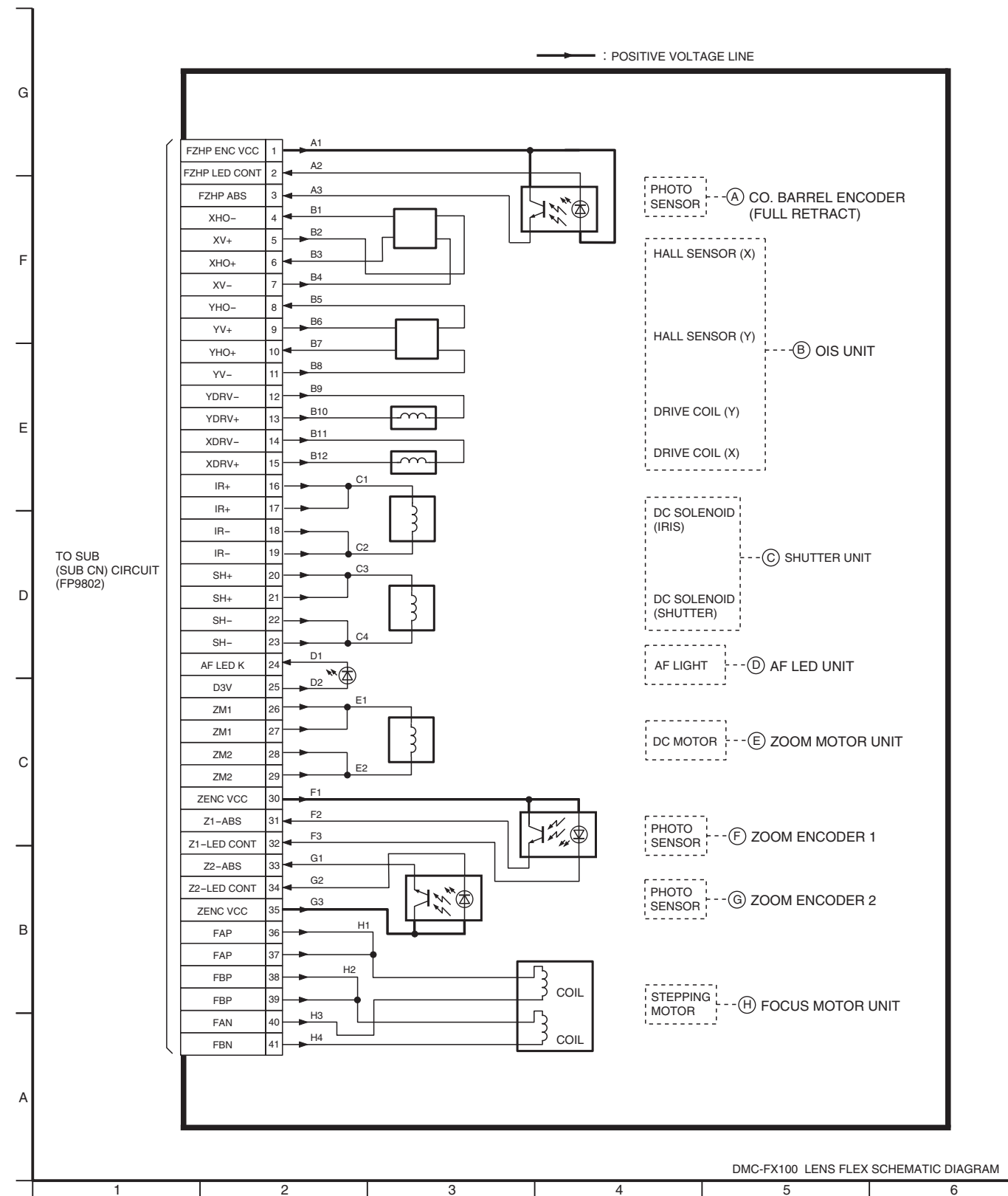

S5.2. AF Assist LED P.C.B. / S5.3. CCD Flex P.C.B.

G
F
E
D
C
B
A

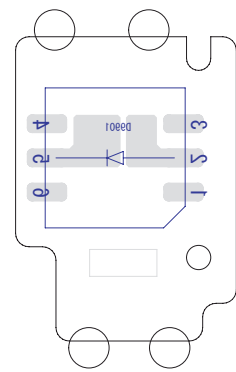

(Component Side)

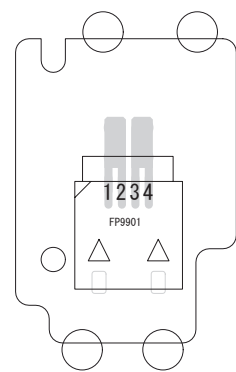

(Foil Side)

DMC-FX100
AF Assist LED P.C.B.

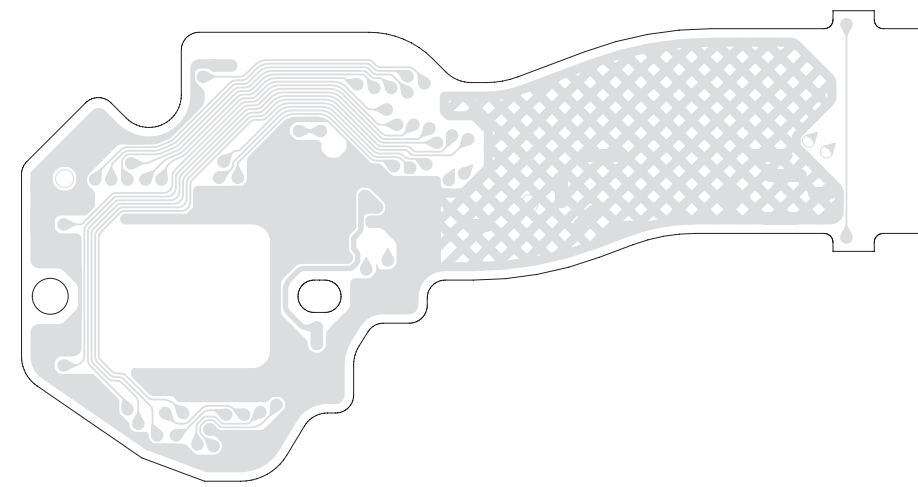

(Component Side)

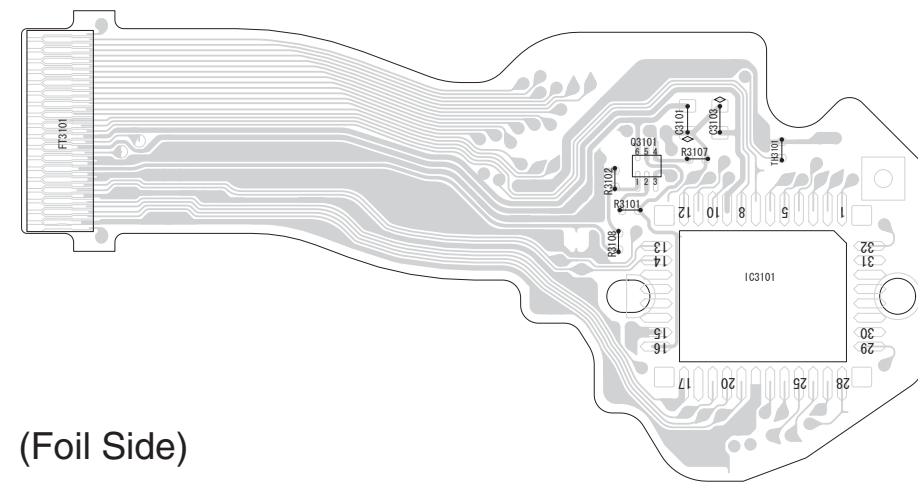

(Foil Side)

DMC-FX100
CCD Flex P.C.B.

1 2 3 4 5 6 7 8 9 10

S5.4. Lens Flex P.C.B.

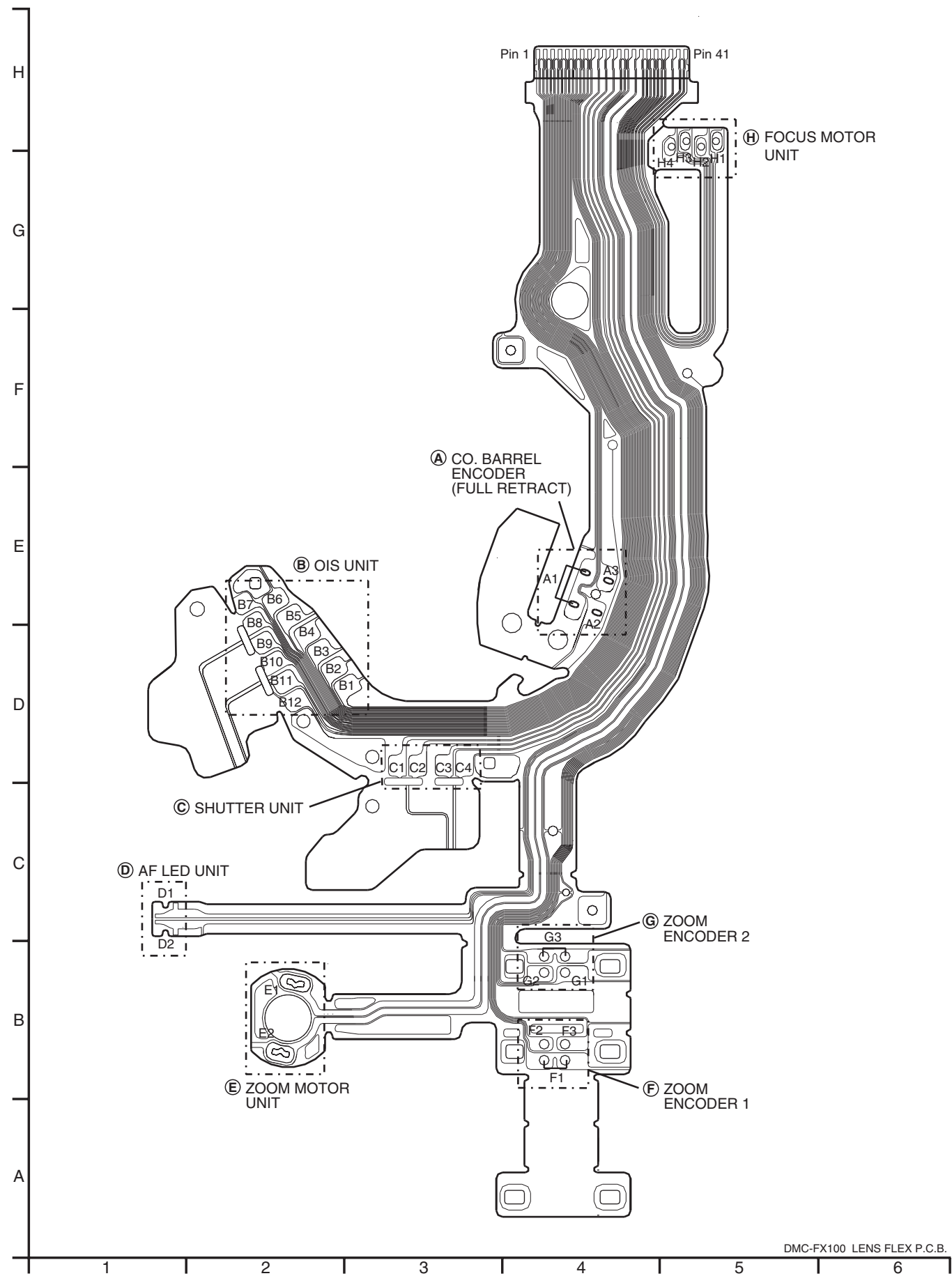

S6. Replacement Parts List

- Note: 1.* Be sure to make your orders of replacement parts according to this list.
2. IMPORTANT SAFETY NOTICE
Components identified with the mark \triangle have the special characteristics for safety.
When replacing any of these components, use only the same type.
3. Unless otherwise specified,
All resistors are in OHMS, K=1,000 OHMS. All capacitors are in MICRO-FARADS (uf), P=uuF.
4. The marking (RTL) indicates the retention time is limited for this item. After the discontinuation of this assembly in production, it will no longer be available.

E.S.D. standards for Electrostatically Sensitive Devices, refer to “PREVENTION OF ELECTROSTATIC DISCHARGE (ESD) TO ELECTROSTATICALLY SENSITIVE (ES) DEVICES” section.

Definition of Parts supplier:

1. Parts marked with [MBI] in the remarks column are supplied from “Matsushita Battery Industrial Co., Ltd.”

DMC-FX100P/PC/PL/EB/EE/EF/EG/E/GC/GD/GK/GN/GT/SG

Ref.No.	Part No.	Part Name & Description	Pcs	Remarks	Ref.No.	Part No.	Part Name & Description	Pcs	Remarks
△ LB8001	J0JCC0000317	FILTER	1						
M8001	L0CZAA000007	MICROPHONE UNITS	1						
P8002	K4ZZ03000329	CONNECTOR 3P	1						
PS8001	K1KB40AA0123	CONNECTOR 40P	1						
△ Q8001	B1JBLP000016	TRANSISTOR	1	E.S.D.					
Q8009	B1DFCG000020	TRANSISTOR	1	E.S.D.					
R8001	ERJ2GEJ122	M.RESISTOR CH 1/16W 1.2K	1						
R8002	ERJ3GEYJ104	M.RESISTOR CH 1/10W 100K	1						
R8003	ERJ3GEYJ560	M.RESISTOR CH 1/10W 56	1						
R8006	ERJ8GEYJ105V	M.RESISTOR CH 1/8W 1M	1						
R8008	ERJ2RHD272	M.RESISTOR CH 1/16W 2.7K	1						
R8009	ERJ2GEJ472	M.RESISTOR CH 1/16W 4.7K	1						
R8010	ERJ2GEJ752X	M.RESISTOR CH 1/16W 7.5K	1						
R8011	ERJ2GEJ123	M.RESISTOR CH 1/16W 12K	1						
R8013	ERJ2RHD153X	M.RESISTOR CH 1/16W 15K	1						
R8021	ERJ2GEJ153	M.RESISTOR CH 1/16W 15K	1						
R8032	ERJ6RED105	M.RESISTOR CH 1/16W 1M	1						
R8033	ERJ6RED105	M.RESISTOR CH 1/16W 1M	1						
R8034	ERJ2GEJ223	M.RESISTOR CH 1/16W 22K	1						
R8035	ERJ2GEJ473	M.RESISTOR CH 1/16W 47K	1						
R8036	ERJ2GEJ103	M.RESISTOR CH 1/16W 10K	1						
R8037	ERJ2GEJ104	M.RESISTOR CH 1/16W 100K	1						
S8001	K0F212A00003	SWITCH	1						
S8002	K0D112B00145	SWITCH	1						
S8003	K0L1CB000003	SWITCH	1						
S8004	K0F111A00541	SWITCH	1						
S8005	K0G188A00003	SWITCH	1						
T8001	G5D1A0000060	TRANSFORMER	1						
VA8001	D4ED18R00008	VARISTORS	1						
##	VEP59044A	AF ASSIST LED P.C.B.		(RTL) E.S.D.					
D9901	B3ADB0000057	DIODE	1	E.S.D.					
FP9901	K1MY04BA0246	CONNECTOR 4P	1						
##	VEK0L09	CCD UNIT		E.S.D.					
C3101	ECJ1VB1C105K	C.CAPACITOR CH 16V 1U	1						
C3103	F1H1A225A051	C.CAPACITOR CH 10V 2.2U	1						
Q3101	UP05C8B00L	TRANSISTOR	1	E.S.D.					
R3101	ERJ2GEJ470	M.RESISTOR CH 1/16W 47	1						
R3102	ERJ2GEJ182	M.RESISTOR CH 1/16W 1.8K	1						
R3107	ERJ2GEJ132	M.RESISTOR CH 1/16W 1.3K	1						
R3108	ERJ2GEJ220	M.RESISTOR CH 1/16W 22	1						
TH3101	D4CC11030026	NTC THERMISTORS	1						

DMC-FX100P/PC/PL/EB/EE/EF/EG/E/GC/GD/GK/GN/GT/SG

Ref.No.	Part No.	Part Name & Description	Pcs	Remarks
201	VPF1224	CAMERA BAG	1	(EXCEPT P,PC)
△ 203	DE-A41BA	BATTERY CHARGER	1	PL
△ 203	DE-A42AA	BATTERY CHARGER	1	EB,EF,EG,E,GN
△ 203	DE-A42BA	BATTERY CHARGER	1	EE,GC,GD,GK,SG
△ 203	DE-A42CA	BATTERY CHARGER	1	GT
△ 204	-----	BATTERY	1	(EXCEPT P,PC)
205	K1HA08CD0007	USB CABLE W/PLUG	1	(EXCEPT P,PC)
206	K1HA08CD0008	AV CABLE W/PLUG	1	(EXCEPT P,PC)
207	VFC4090	HAND STRAP	1	(EXCEPT P,PC)
208	VFF0382-S	CD-ROM (OVERSEAS)	1	(EXCEPT P,PC)
				See "Notes"
209	VPK3342	PACKING CASE	1	(-S)(EXCEPT P,PC,GK)
209	VPK3346	PACKING CASE	1	(-K)(EXCEPT P,PC,GK)
209	VPK3350	PACKING CASE	1	(-N)(EXCEPT GK)
209	VPK3343	PACKING CASE	1	GKS
209	VPK3347	PACKING CASE	1	GKK
209	VPK3351	PACKING CASE	1	GKN
210	VPN6597	CUSHION	1	(EXCEPT P,PC)
211	VYQ3509	BATTERY PROTECTION CASE U	1	(EXCEPT P,PC)
212	VPF1100	BAG, POLYETHYLENE	1	(EXCEPT P,PC)
△ 213	VFF0383	CD-ROM (INSTRUCTION BOOK)	1	PL,EG,E,GC,SG
△ 214	VQT1J06	SIMPLIFIED O/I (ENGLISH/SPANISH)	1	PL
△ 214	VQT1J07	SIMPLIFIED O/I (PORTUGUESE)	1	PL
△ 214	VQT1F66	INSTRUCTION BOOK (ENGLISH)	1	EB
△ 214	VQT1F67	INSTRUCTION BOOK (RUSSIAN)	1	EE
△ 214	VQT1F68	INSTRUCTION BOOK (UKRAINIAN)	1	EE
△ 214	VQT1F59	INSTRUCTION BOOK (FRENCH)	1	EF
△ 214	VQT1J09	SIMPLIFIED O/I (GERMAN/FRENCH)	1	EG
△ 214	VQT1J10	SIMPLIFIED O/I (ITALIAN/DUTCH)	1	EG
△ 214	VQT1J11	SIMPLIFIED O/I (SPANISH/PORTUGUESE)	1	EG
△ 214	VQT1J13	SIMPLIFIED O/I (SWEDISH/DANISH)	1	E
△ 214	VQT1J14	SIMPLIFIED O/I (POLISH/CZECH)	1	E
△ 214	VQT1J15	SIMPLIFIED O/I (HUNGARIAN)	1	E
△ 214	VQT1J17	SIMPLIFIED O/I (ENGLISH/ CHINESE(TRADITIONAL))	1	GC,SG
△ 214	VQT1J18	SIMPLIFIED O/I (ARABIC/PERSIAN)	1	GC,SG
△ 214	VQT1F76	INSTRUCTION BOOK (KOREAN)	1	GD
△ 214	VQT1F74	INSTRUCTION BOOK (CHINESE(SIMPLIFIED))	1	GK
△ 214	VQT1F75	INSTRUCTION BOOK (ENGLISH)	1	GN
△ 214	VQT1F73	INSTRUCTION BOOK (CHINESE(TRADITIONAL))	1	GT
215	VQT1J08	O/I SOFTWARE (ENGLISH/SPANISH/ PORTUGUESE)	1	PL
215	VQT1J01	O/I SOFTWARE (ENGLISH)	1	EB,GN
215	VQT1J02	O/I SOFTWARE (RUSSIAN/UKRAINIAN)	1	EE
215	VQT1J00	O/I SOFTWARE (FRENCH)	1	EF
215	VQT1J12	O/I SOFTWARE (GERMAN/FRENCH/ITALIAN/ DUTCH/SPANISH/PORTUGUESE)	1	EG
215	VQT1J16	O/I SOFTWARE (SWEDISH/DANISH/POLISH/ CZECH/HUNGARIAN)	1	E

Ref.No.	Part No.	Part Name & Description	Pcs	Remarks
215	VQT1J19	O/I SOFTWARE (ENGLISH/ARABIC/PERSIAN/ CHINESE(TRADITIONAL))	1	GC,SG
215	VQT1J05	O/I SOFTWARE (KOREAN)	1	GD
215	VQT1J04	O/I SOFTWARE (CHINESE(SIMPLIFIED))	1	GK
215	VQT1J03	O/I SOFTWARE (CHINESE(TRADITIONAL))	1	GT
△ 216	RJA0078-1X	AC CORD W/PLUG	1	GD
△ 217	K2CA2CA00020	AC CORD W/PLUG	1	GK
△ 217	K2CA2CA00027	AC CORD W/PLUG	1	GT
△ 218	K2CJ2DA00008	AC CORD W/PLUG	1	GN
△ 219	K2CT3CA00004	AC CORD W/PLUG	1	EB,GC,SG
△ 220	K2CQ2CA00006	AC CORD W/PLUG	1	EE,EF,EG,E,GC,SG

S7. Exploded View

S7.1. Frame and Casing Section

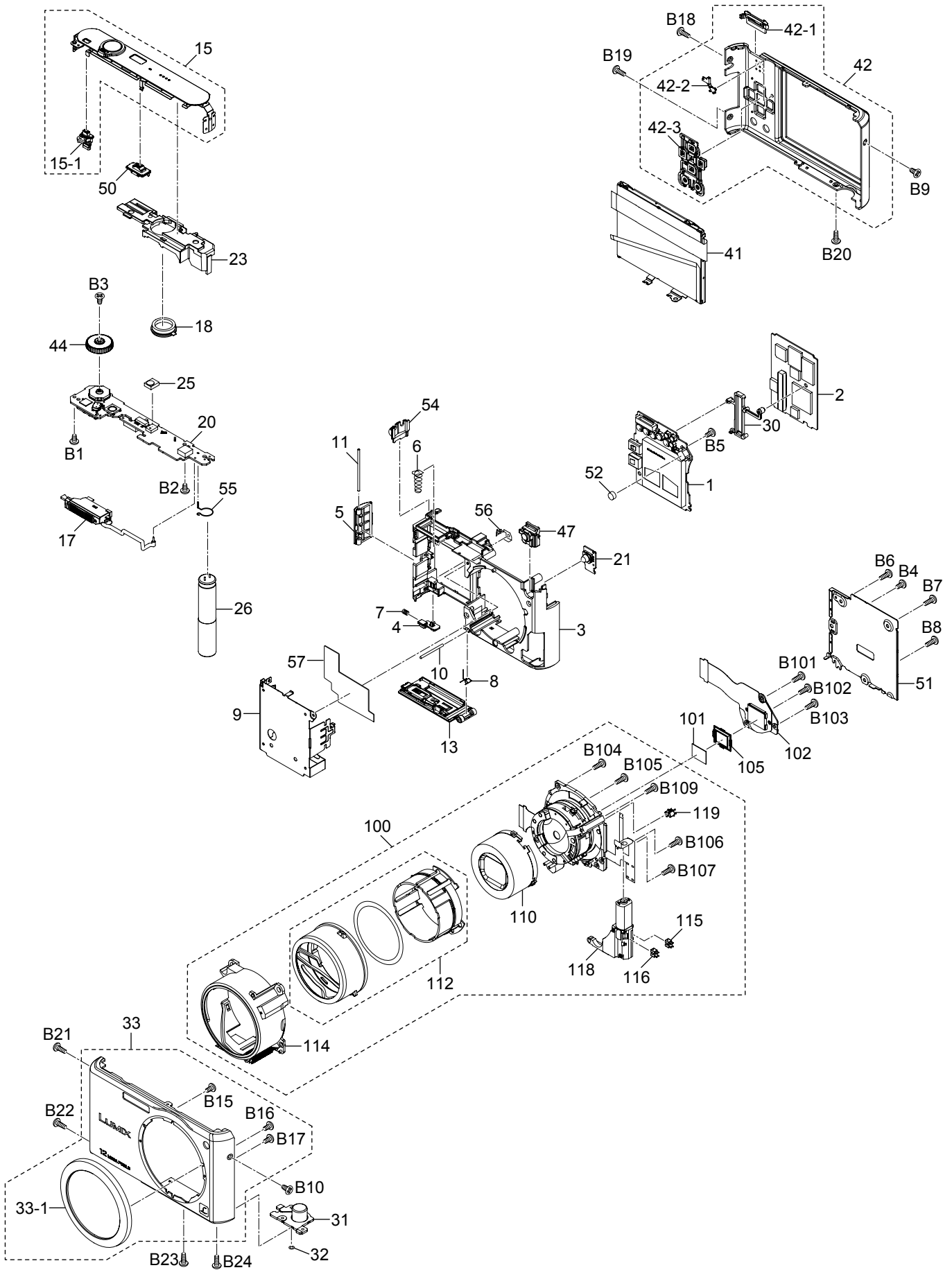

S7.2. Packing Parts and Accessories Section (1)

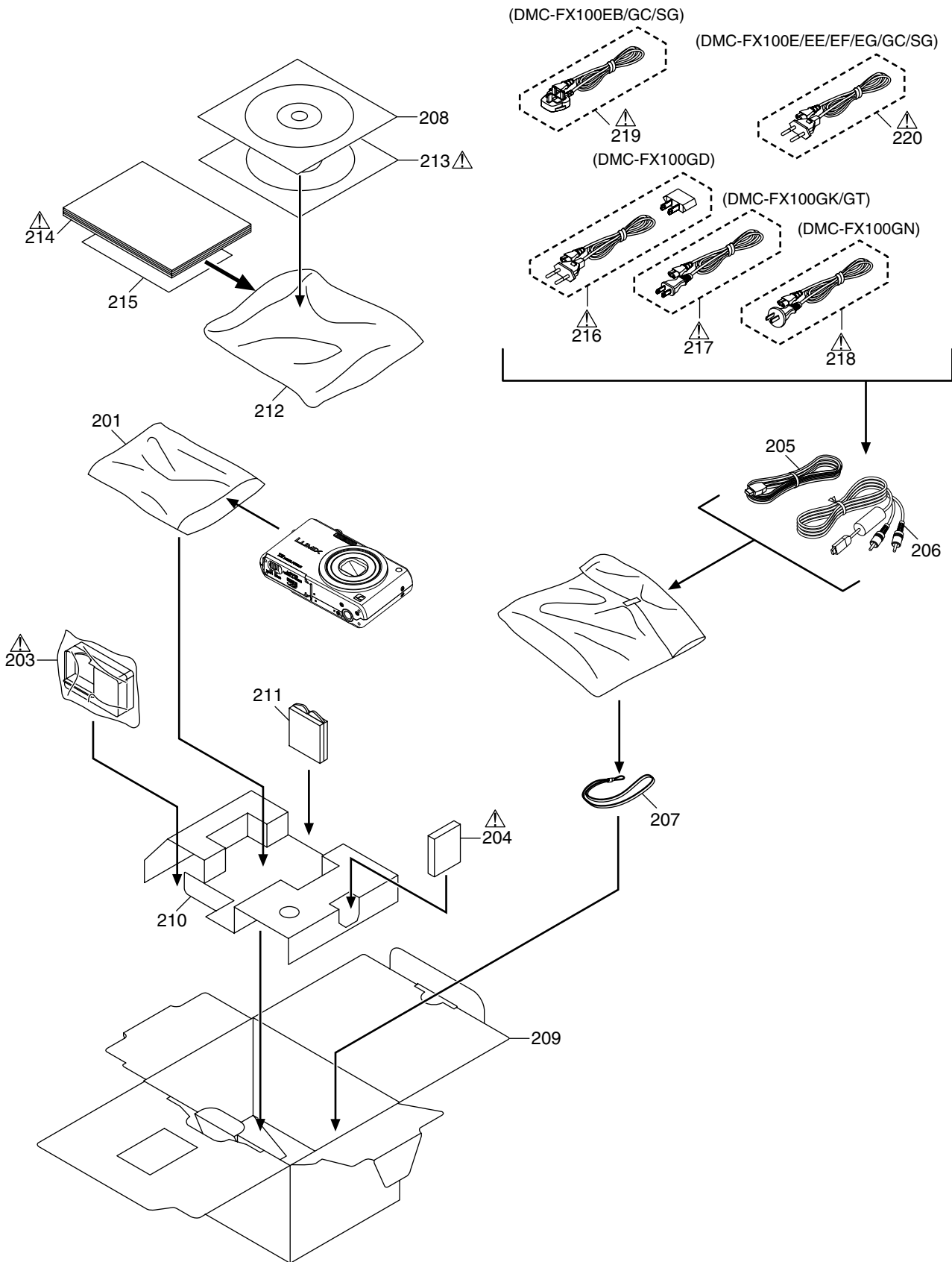

S7.3. Packing Parts and Accessories Section (2)

