

Service Manual

Digital Camera

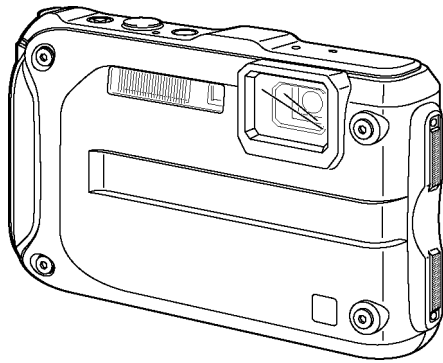

Model No. **DMC-FT3EB**
DMC-FT3EE
DMC-FT3EF
DMC-FT3EG
DMC-FT3EP
DMC-FT3GC
DMC-FT3GN
DMC-FT3SG
DMC-TS3P
DMC-TS3PC
DMC-TS3PU
DMC-TS3GH
DMC-TS3GD
DMC-TS3GT

VOL.1

Colours

- (A).....Blue Type (Except DMC-FT3EE/EF, DMC-TS3GT)
- (D).....Orange Type (Except DMC-FT3EB/SG)
- (S).....Silver Type (Except DMC-FT3EB/EF, DMC-TS3GD/GT/PC)
- (R).....Red Type (Except DMC-FT3EE, DMC-TS3GD/GH)

WARNING

This service information is designed for experienced repair technicians only and is not designed for use by the general public. It does not contain warnings or cautions to advise non-technical individuals of potential dangers in attempting to service a product. Products powered by electricity should be serviced or repaired only by experienced professional technicians. Any attempt to service or repair the product or products dealt with in this service information by anyone else could result in serious injury or death.

Panasonic®

© Panasonic Corporation 2011.
Unauthorized copying and distribution is a violation of law.

TABLE OF CONTENTS

	PAGE	PAGE
1 Safety Precautions	3	
1.1. General Guidelines	3	
1.2. Leakage Current Cold Check	3	
1.3. Leakage Current Hot Check (See Figure 1).....	3	
1.4. How to Discharge the Capacitor on Flash P.C.B.	4	
2 Warning	5	
2.1. Prevention of Electrostatic Discharge (ESD) to Electrostatic Sensitive (ES) Devices	5	
2.2. How to Recycle the Lithium Ion Battery (U.S. Only).....	5	
2.3. Caution for AC Cord (For EB/GC/GH/SG).....	6	
2.4. How to Replace the Lithium Battery.....	7	
3 Service Navigation	9	
3.1. Introduction	9	
3.2. Air-leak test (inspection).....	9	
3.3. Replacing the waterproof packing (waterproof seal)	9	
3.4. Lens Unit	9	
3.5. About IC9301 (COMPASS) [On the TOP FPC UNIT].....	10	
3.6. Important Notice 1:(Other than U.S.A. and Canadian Market)	10	
3.7. General Description About Lead Free Solder (PbF)	11	
3.8. How to Define the Model Suffix (NTSC or PAL model).....	12	
4 Specifications	16	
5 Location of Controls and Components	22	
6 Service Mode	24	
6.1. Error Code Memory Function	24	
6.2. ICS (Indication of additional Camera Settings when picture was taken) function	27	
7 Troubleshooting Guide	29	
7.1. Service and Check Procedures	29	
7.2. Air-leak Test	32	
7.3. Checking Method of GPS failure.....	33	
7.4. Checking Method of compass, altimeter, & barometer	34	
8 Service Fixture & Tools	38	
8.1. Service Fixture and Tools	38	
8.2. When Replacing the Main P.C.B.	39	
8.3. Service Position	39	
9 Disassembly and Assembly Instructions	40	
9.1. Disassembly Flow Chart.....	40	
9.2. P.C.B. Location	40	
9.3. Disassembly Procedures.....	41	
10 Measurements and Adjustments	49	
10.1. Introduction	49	
10.2. Before Disassembling the unit.....	49	
10.3. Details of Electrical Adjustment.....	51	
10.4. After Adjustment.....	54	
11 Maintenance	55	
11.1. Cleaning Lens and LCD Panel	55	

1 Safety Precautions

1.1. General Guidelines

1. IMPORTANT SAFETY NOTICE

There are special components used in this equipment which are important for safety. These parts are marked by  in the Schematic Diagrams, Circuit Board Layout, Exploded Views and Replacement Parts List. It is essential that these critical parts should be replaced with manufacturer's specified parts to prevent X-RADIATION, shock fire, or other hazards. Do not modify the original design without permission of manufacturer.

2. An Isolation Transformer should always be used during the servicing of AC Adaptor whose chassis is not isolated from the AC power line. Use a transformer of adequate power rating as this protects the technician from accidents resulting in personal injury from electrical shocks. It will also protect AC Adaptor from being damaged by accidental shorting that may occur during servicing.
3. When servicing, observe the original lead dress. If a short circuit is found, replace all parts which have been overheated or damaged by the short circuit.
4. After servicing, see to it that all the protective devices such as insulation barriers, insulation papers shields are properly installed.
5. After servicing, make the following leakage current checks to prevent the customer from being exposed to shock hazards.

1.2. Leakage Current Cold Check

1. Unplug the AC cord and connect a jumper between the two prongs on the plug.
2. Measure the resistance value, with an ohmmeter, between the jumpered AC plug and each exposed metallic cabinet part on the equipment such as screwheads, connectors, control shafts, etc. When the exposed metallic part has a return path to the chassis, the reading should be between $1M\Omega$ and $5.2M\Omega$. When the exposed metal does not have a return path to the chassis, the reading must be infinity.

1.3. Leakage Current Hot Check (See Figure 1)

1. Plug the AC cord directly into the AC outlet. Do not use an isolation transformer for this check.
2. Connect a $1.5k\Omega$, 10 W resistor, in parallel with a $0.15\mu F$ capacitor, between each exposed metallic part on the set and a good earth ground, as shown in Figure 1.
3. Use an AC voltmeter, with $1 k\Omega/V$ or more sensitivity, to measure the potential across the resistor.
4. Check each exposed metallic part, and measure the voltage at each point.
5. Reverse the AC plug in the AC outlet and repeat each of the above measurements.
6. The potential at any point should not exceed 0.75 V RMS. A leakage current tester (Simpson Model 229 or equivalent) may be used to make the hot checks, leakage current must not exceed $1/2$ mA. In case a measurement is outside of the limits specified, there is a possibility of a shock hazard, and the equipment should be repaired and rechecked before it is returned to the customer.

Hot-Check Circuit

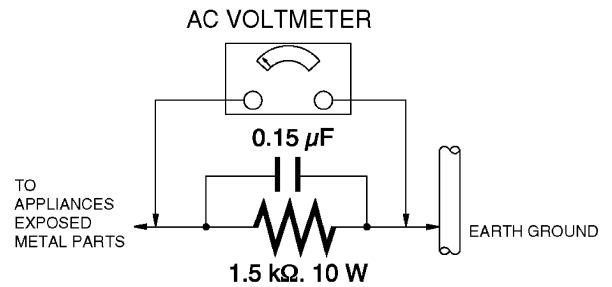

Figure 1

1.4. How to Discharge the Capacitor on Flash P.C.B.

- This unit equipped with two pieces of capacitors as flash charging capacitors.
"Either one of the capacitor discharging operation" makes discharging for others as well.

CAUTION:

1. **Be sure to discharge the capacitor on FLASH P.C.B.**
2. **Be careful of the high voltage circuit on FLASH P.C.B. when servicing.**

[Discharging Procedure]

1. Refer to the disassemble procedure and remove the necessary parts/unit.
2. Put the insulation tube onto the lead part of Resistor (ERG5SJ102:1k Ω /5W).
(An equivalent type of resistor may be used.)
3. Put the resistor between both terminals of capacitor on FLASH P.C.B. for approx. 5 seconds.
4. After discharging confirm that the capacitor voltage is lower than 10V using a voltmeter.

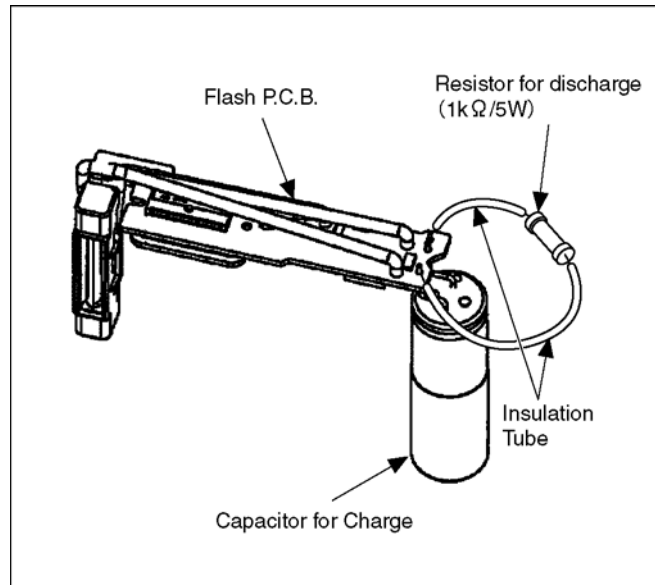

Fig. F1

2 Warning

2.1. Prevention of Electrostatic Discharge (ESD) to Electrostatic Sensitive (ES) Devices

Some semiconductor (solid state) devices can be damaged easily by static electricity. Such components commonly are called Electrostatically Sensitive (ES) Devices.

Examples of typical ES devices are CCD image sensor, IC (integrated circuits) and some field-effect transistors and semiconductor "chip" components.

The following techniques should be used to help reduce the incidence of component damage caused by electrostatic discharge (ESD).

1. Immediately before handling any semiconductor component or semiconductor-equipped assembly, drain off any ESD on your body by touching a known earth ground. Alternatively, obtain and wear a commercially available discharging ESD wrist strap, which should be removed for potential shock reasons prior to applying power to the unit under test.
2. After removing an electrical assembly equipped with ES devices, place the assembly on a conductive surface such as aluminum foil, to prevent electrostatic charge buildup or exposure of the assembly.
3. Use only a grounded-tip soldering iron to solder or unsolder ES devices.
4. Use only an antistatic solder removal device. Some solder removal devices not classified as **antistatic (ESD protected)** can generate electrical charge sufficient to damage ES devices.
5. Do not use freon-propelled chemicals. These can generate electrical charges sufficient to damage ES devices.
6. Do not remove a replacement ES device from its protective package until immediately before you are ready to install it. (Most replacement ES devices are packaged with leads electrically shorted together by conductive foam, aluminum foil or comparable conductive material).
7. Immediately before removing the protective material from the leads of a replacement ES device, touch the protective material to the chassis or circuit assembly into which the device will be installed.

CAUTION:

Be sure no power is applied to the chassis or circuit, and observe all other safety precautions.

8. Minimize bodily motions when handling unpackaged replacement ES devices. (Otherwise harmless motion such as the brushing together of your clothes fabric or the lifting of your foot from a carpeted floor can generate static electricity (ESD) sufficient to damage an ES device).

2.2. How to Recycle the Lithium Ion Battery (U.S. Only)

ENGLISH



A lithium ion/polymer battery that is recyclable powers the product you have purchased. Please call 1-800-8-BATTERY for information on how to recycle this battery.

FRANÇAIS



L'appareil que vous vous êtes procuré est alimenté par une batterie au lithium-ion/polymère recyclable. Pour des renseignements sur le recyclage de la batterie, veuillez composer le 1-800-8-BATTERY.

2.3. Caution for AC Cord (For EB/GC/GH/SG)

2.3.1. Information for Your Safety

IMPORTANT

Your attention is drawn to the fact that recording of pre-recorded tapes or discs or other published or broadcast material may infringe copyright laws.

WARNING

To reduce the risk of fire or shock hazard, do not expose this equipment to rain or moisture.

CAUTION

To reduce the risk of fire or shock hazard and annoying interference, use the recommended accessories only.

FOR YOUR SAFETY

DO NOT REMOVE THE OUTER COVER

To prevent electric shock, do not remove the cover. No user serviceable parts inside. Refer servicing to qualified service personnel.

2.3.2. Caution for AC Mains Lead

For your safety, please read the following text carefully.

This appliance is supplied with a moulded three-pin mains plug for your safety and convenience.

A 5-ampere fuse is fitted in this plug.

Should the fuse need to be replaced please ensure that the replacement fuse has a rating of 5 amperes and it is approved by ASTA or BSI to BS1362

Check for the ASRA mark or the BSI mark on the body of the fuse.



If the plug contains a removable fuse cover you must ensure that it is refitted when the fuse is replaced.

If you lose the fuse cover, the plug must not be used until a replacement cover is obtained.

A replacement fuse cover can be purchased from your local Panasonic Dealer.

If the fitted moulded plug is unsuitable for the socket outlet in your home then the fuse should be removed and the plug cut off and disposed of safely.

There is a danger of severe electrical shock if the cut off plug is inserted into any 13-ampere socket.

If a new plug is to be fitted please observe the wiring code as shown below.

If in any doubt, please consult a qualified electrician.

2.3.2.1. Important

The wires in this mains lead are coloured in accordance with the following code:

Blue	Neutral
Brown	Live

As the colours of the wires in the mains lead of this appliance may not correspond with the coloured markings identifying the terminals in your plug, proceed as follows:

The wire which is coloured BLUE must be connected to the terminal in the plug which is marked with the letter N or coloured BLACK.

The wire which is coloured BROWN must be connected to the terminal in the plug which is marked with the letter L or coloured RED.

Under no circumstances should either of these wires be connected to the earth terminal of the three pin plug, marked with the letter E or the Earth Symbol.

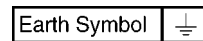

2.3.2.2. Before Use

remove the Connector Cover as follows.

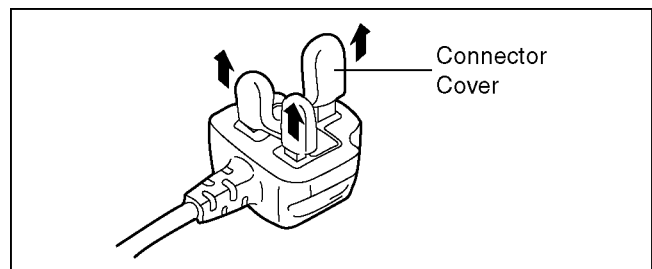

2.3.2.3. How to Replace the Fuse

1. Remove the Fuse Cover with a screwdriver.

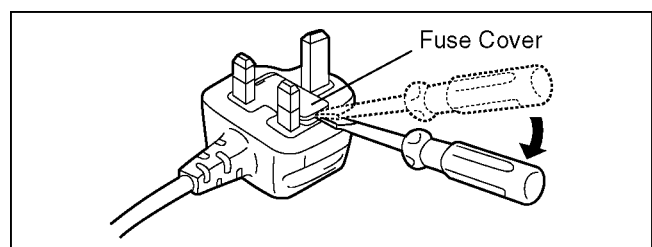

2. Replace the fuse and attach the Fuse cover.

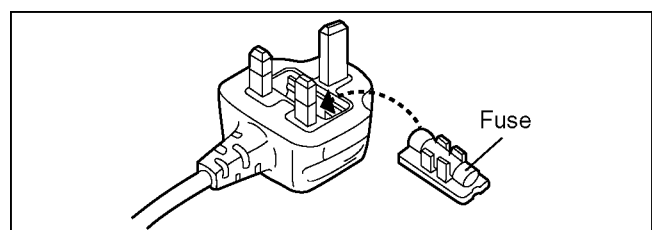

2.4. How to Replace the Lithium Battery

2.4.1. Replacement Procedure

1. Remove the Main P.C.B. (Refer to Disassembly Procedures.)
2. Remove the Lithium battery (Ref. No. **B6402** at foil side of Main P.C.B.) and then replace it into new one.

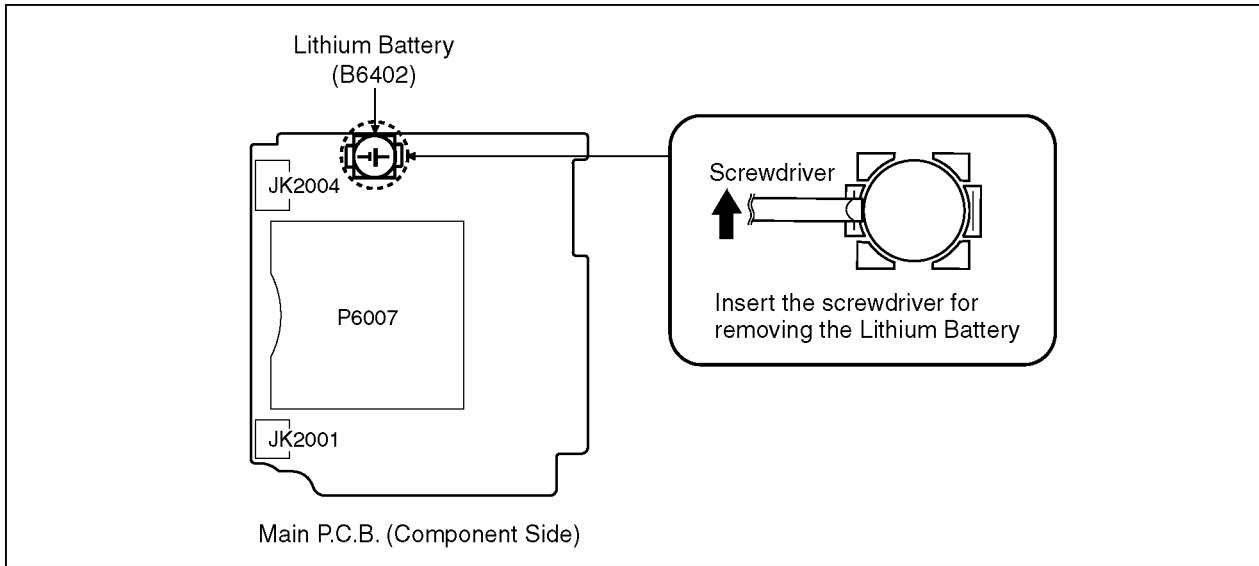

CAUTION

Danger of explosion if battery is incorrectly replaced.
Replace only with the same or equivalent type.

CAUTION

The battery used in this device may present a risk of fire or chemical burn if mistreated.
Do not recharge, disassemble, heat above 100°C (212°F), or incinerate.
Replace battery with Panasonic part number ML-421S/ZTK only.
Use of another battery may present a risk of fire or explosion.
Dispose of used battery promptly.
Keep away from children.
Do not disassemble and do not dispose of in fire.

Note:

The lithium battery is a critical component.

(Type No.: ML-421S/ZTK **Manufactured by Energy Company, Panasonic Corporation**)

It must never be subjected to excessive heat or discharge.

It must therefore only be fitted in equipment designed specifically for its use.

Replacement batteries must be of the same type and manufacture.

They must be fitted in the same manner and location as the original battery, with the correct polarity contacts observed.

Do not attempt to re-charge the old battery or re-use it for any other purpose.

It should be disposed of in waste products destined for burial rather than incineration.

(For English)

CAUTION

Danger of explosion if battery is incorrectly replaced.
Replace only with the same or equivalent type recommended by the manufacturer.
Dispose of used batteries according to the manufacturer's instructions.

(For German)

ACHTUNG

Explosionsgefahr bei falschem Anbringen der Batterie. Ersetzen Sie nur mit einem äquivalentem vom Hersteller empfohlenem Typ.
Behandeln Sie gebrauchte Batterien nach den Anweisungen des Herstellers.

(For French)

MISE EN GARDE

Une batterie de remplacement inappropriée peut exploser. Ne remplacez qu'avec une batterie identique ou d'un type recommandé par le fabricant. L'élimination des batteries usées doit être faite conformément aux instructions du fabricant.

Note:

Above caution is applicable for a battery pack which is for DMC-FT3 and DMC-TS3 series, as well.

Danger of explosion if battery is incorrectly replaced.

Replace only with the same or equivalent type recommended by the manufacturer.

Dispose of used batteries according to the manufacturer's instructions.

3 Service Navigation

3.1. Introduction

This service manual contains technical information, which will allow service personnel's to understand and service this model. Please place orders using the parts list and not the drawing reference numbers. If the circuit is changed or modified, the information will be followed by service manual to be controlled with original service manual.

3.2. Air-leak test (inspection)

Waterproof/Dustproof Performance
This camera's waterproof/dustproof rating complies with the "IPX8" and "IP6X" ratings. Provided the care and maintenance guidelines described in this document are strictly followed, this camera can operate underwater, to a depth not exceeding 12 m (40 feet) for a time not exceeding 60 minutes. (*1)

Anti-shock Performance
This camera also complies with "MIL-STD 810F Method 516.5-Shock". The camera has cleared a drop test from a height of 2 m (6.6 feet) onto 3 cm (0.10 feet) thick plywood. In most cases this camera should not sustain any damage if dropped from a height not exceeding 2 m (6.6 feet). (*2)

This does not guarantee no destruction, no malfunction, or waterproofing in all conditions.

*1 This means that the camera can be used underwater for specified time in specified pressure in accordance with the handling method established by Panasonic.

*2 "MIL-STD 810F Method 516.5-Shock" is the test method standard of the U.S. Defense Department, which specifies performing drop tests from a height of 122 cm (4.0 feet), at 26 orientations (8 corners, 12 ridges, 6 faces) using 5 sets of devices, and passing the 26 orientation drops within 5 devices. (If failure occurs during the test, a new set is used to pass the drop orientation test within a total of 5 devices)

Panasonic's test method is based on the above "MIL-STD 810F Method 516.5-Shock". However, the drop height was changed from 122 cm (4.0 feet) to 200 cm (6.6 feet) dropping onto 3 cm (0.10 feet) thick plywood. This drop test was passed. (Disregarding appearance change such as loss of paint or distortion of the part where drop impact is applied.)

- Due to the above characteristics of the products, perform the air-leak test (inspection) using Air -leak tester (Part No.:RFKZ0528) before/after servicing including assembly and/or assembly process.

Note:

The purpose of the air-leak test before servicing is that whether the malfunction occurred due to air-leak or not.

- When servicing, refer to the "7.Troubleshooting" section for details.

3.3. Replacing the waterproof packing (waterproof seal)

- The integrity of the waterproof packing may decrease about 1 year, with use and age. (We recommend end users to replace the waterproof packing (waterproof seal) at least once each year described in the operating instructions.)
- As for replacement procedure, refer to the 7.1.2. Periodical maintenance (Packing replacement) flow for details.

3.4. Lens Unit

- Since the lens unit for this model is assembled with high accuracy manufacturing technologies, it is not allowed to disassemble/assemble the lens unit, in terms of performance retention. When servicing, it has to be handled the "Lens with CCD unit" as the smallest part size. Confirm the replacement part list and exploded views for details.

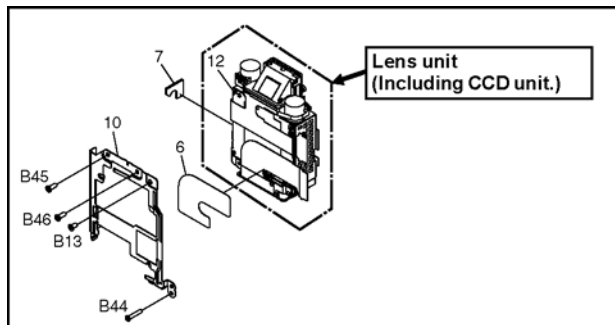

3.5. About IC9301 (COMPASS) [On the TOP FPC UNIT]

When IC9301 is defects and necessary to be replaced, replace with whole TOP FPC UNIT as a unit.

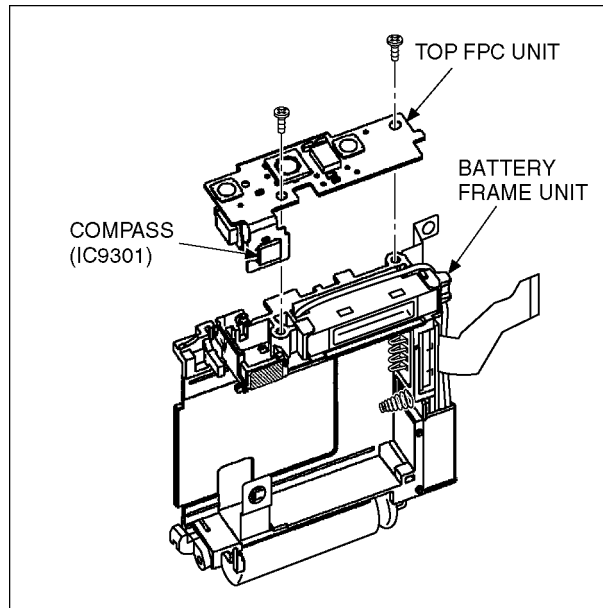

3.6. Important Notice 1:(Other than U.S.A. and Canadian Market)

1. The service manual does not contain the following information, because of the impossibility of servicing at component level without concerned equipment/facilities.
 - a. Schematic diagram, Block Diagram and P.C.B. layout of MAIN P.C.B.
 - b. Parts list for individual parts for MAIN P.C.B.

When a part replacement is required for repairing MAIN P.C.B., replace as an assembled parts. (MAIN P.C.B.)

3.7. General Description About Lead Free Solder (PbF)

The lead free solder has been used in the mounting process of all electrical components on the printed circuit boards used for this equipment in considering the globally environmental conservation.

The normal solder is the alloy of tin (Sn) and lead (Pb). On the other hand, the lead free solder is the alloy mainly consists of tin (Sn), silver (Ag) and Copper (Cu), and the melting point of the lead free solder is higher approx.30 °C (86 °F) more than that of the normal solder.

Definition of P.C.B. Lead Free Solder being used

The letter of PbF is printed either foil side or components side on the P.C.B. using the lead free solder. (See right figure)	PbF
---	------------

Service caution for repair work using Lead Free Solder (PbF)

- The lead free solder has to be used when repairing the equipment for which the lead free solder is used.
- (Definition: The letter of **PbF** is printed on the P.C.B. using the lead free solder.)
- To put lead free solder, it should be well molten and mixed with the original lead free solder.
- Remove the remaining lead free solder on the P.C.B. cleanly for soldering of the new IC.
- Since the melting point of the lead free solder is higher than that of the normal lead solder, it takes the longer time to melt the lead free solder.
- Use the soldering iron (more than 70W) equipped with the temperature control after setting the temperature at 350±30 degrees C (662±86 °F).

Recommended Lead Free Solder (Service Parts Route.)

- The following 3 types of lead free solder are available through the service parts route.
 - RFKZ03D01KS----- (0.3mm 100g Reel)
 - RFKZ06D01KS----- (0.6mm 100g Reel)
 - RFKZ10D01KS----- (1.0mm 100g Reel)

Note

* Ingredient: tin (Sn) 96.5%, silver (Ag) 3.0%, Copper (Cu) 0.5%, Cobalt (Co) / Germanium (Ge) 0.1 to 0.3%

3.8. How to Define the Model Suffix (NTSC or PAL model)







There are eight kinds of DMC-FT3/TS3, regardless of the colours.

- a) DMC-FT3 (Japan domestic model.)/SG
- b) DMC-TS3P/PC
- c) DMC-FT3EB/EF/EG/EP
- d) DMC-FT3EE
- e) DMC-TS3GT
- f) DMC-FT3GN
- g) DMC-TS3GD
- h) DMC-FT3GC, DMC-TS3GH/PU

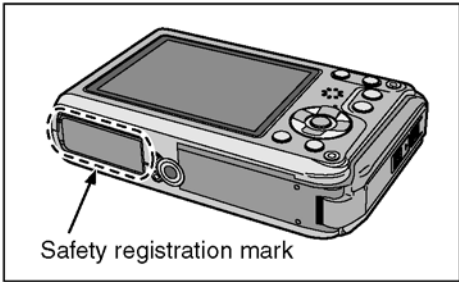
What is the difference is that the "INITIAL SETTINGS" data which is stored in Flash ROM mounted on Main P.C.B.

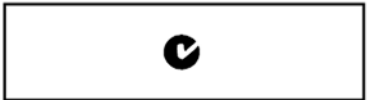
3.8.1. Defining methods

To define the model suffix to be serviced, refer to the nameplate which is putted on the bottom side of the Unit.

<p>a) DMC-FT3 (Japan domestic model), DMC-FT3SG The nameplate for this model shows the following Safety registration mark.</p> 	 <p>Safety registration mark</p>
<p>b) DMC-TS3P/PC The nameplate for these models show the following Safety registration mark.</p> 	
<p>c) DMC-FT3EB/EF/EG/EP The nameplate for these models show the following Safety registration mark.</p> 	<p>f) DMC-FT3GN The nameplate for this model show the following Safety registration mark.</p> 
<p>d) DMC-FT3EE The nameplate for this model show the following Safety registration mark.</p> 	<p>g) DMC-TS3GD The nameplate for this model show the following Safety registration mark.</p> 
<p>e) DMC-TS3GT The nameplate for this model show the following Safety registration mark.</p> 	<p>h) DMC-FT3GC, DMC-TS3GH/PU The nameplate for these models do not show any above safety registration mark.</p>

Note:

After replacing the MAIN P.C.B., be sure to achieve adjustment.

The Maintenance software (DIAS) is available at "software download" on the "Support Information from NWBG/VDBG-AVC" web-site in "TSN system".

3.8.2. INITIAL SETTINGS:

After replacing the MAIN P.C.B., be sure to perform the initial settings after achieving the adjustment by ordering the following procedure in accordance with model suffix of the unit.

1. IMPORTANT NOTICE:

Before proceeding Initial settings, be sure to read the following CAUTIONS.

CAUTION 1:(INITIAL SETTINGS)

---AFTER REPLACING THE MAIN P.C.B. ---

[Other than "EG, EF, EB and EP" models : (VEP56129A is used as a Main P.C.B.)]

*.The model suffix can be chosen **JUST ONE TIME.**

(Effective model suffix : DMC-FT3 " EE/GC/GN/SG")

DMC-TS3 " GH/GD/GT/P/PC/PU")

*.Once one of the model suffix has been chosen, the model suffix lists will not be displayed, thus, it can not be changed.

[Only for "EG, EF, EB and EP" models : (VEP56129B is used as a Main P.C.B.)]

*.From the beginning, only "EG, EF, EB, and EP" are displayed as a model suffix lists, and these are displayed from the second times as well.

CAUTION 2:(Stored picture image data in the unit)

This unit employs "Built-in Memory" for picture image data recording.(Approx.19MB)

After proceeding "INITIAL SETTINGS", the picture image data stored in the unit is erased.

2. PROCEDURES:

- Precautions: Read the above "CAUTION 1" and "CAUTION 2", carefully
- Preparation:
 1. Attach the Battery or AC Adaptor with a DC coupler to the unit.
 2. Set the mode dial to the NORMAL PICTURE mode.

Note:

If the mode dial position is other than NORMAL PICTURE mode, it does not display the initial settings menu.

• Step 1. The temporary cancellation of "INITIAL SETTINGS":

While keep pressing "UP of Cursor button" and MOTION PICTURE button simultaneously, turn the Power on.

• Step 2. The cancellation of "INITIAL SETTINGS":

Press the PLAYBACK button.

Press "UP of Cursor button" and MOTION PICTURE button simultaneously, then turn the Power off.

• Step 3. Turn the Power on:

Turn the Power on.

• Step 4. Display the "INITIAL SETTINGS" menu:

Note:

If the unit is other than NORMAL PICTURE mode, it does not display the initial settings menu.

While keep pressing MENU/SET and "RIGHT of Cursor button" simultaneously, turn the Power off.

The "INITIAL SETTINGS" menu is displayed.

There are two kinds of "INITIAL SETTINGS" menu form as follows:

[CASE 1. After replacing MAIN P.C.B.]

[Except "EG, EF, EB and EP" models : (VEP56129A is used as a Main P.C.B.)]

When MAIN P.C.B. has just been replaced, the following model suffix list is displayed as follows. (Four pages in total)

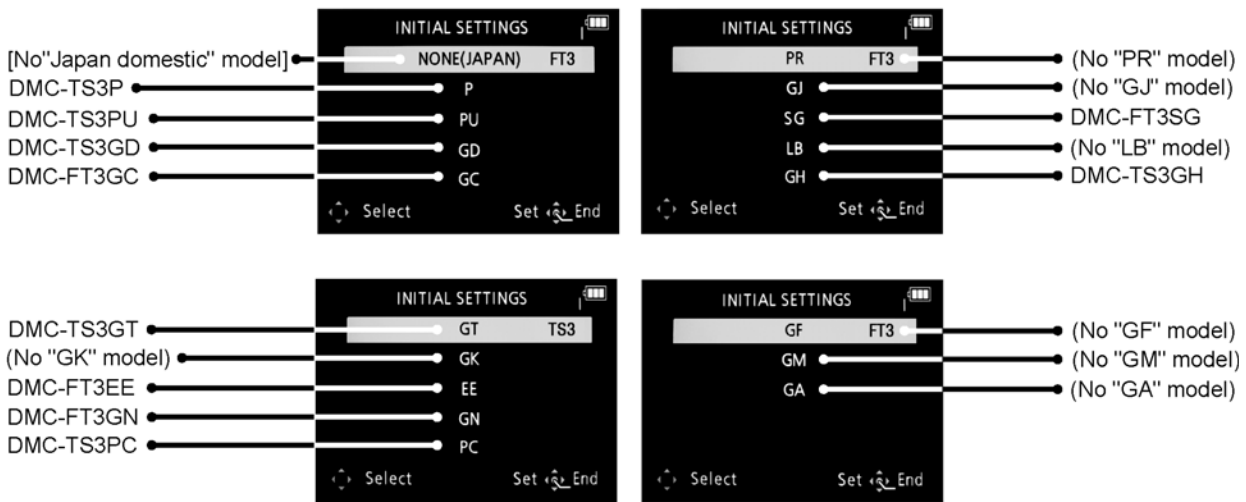

[Only for "EG, EF, EB and EP" models : (VEP56129B is used as a Main P.C.B.)]

When MAIN P.C.B. has just been replaced, the following model suffix list is displayed as follows. (Two pages in total)



[CASE 2. Other than "After replacing MAIN P.C.B."]

< Other than "EG/EF/EB/EP" models >

< Only "EG/EF/EB/EP" models >

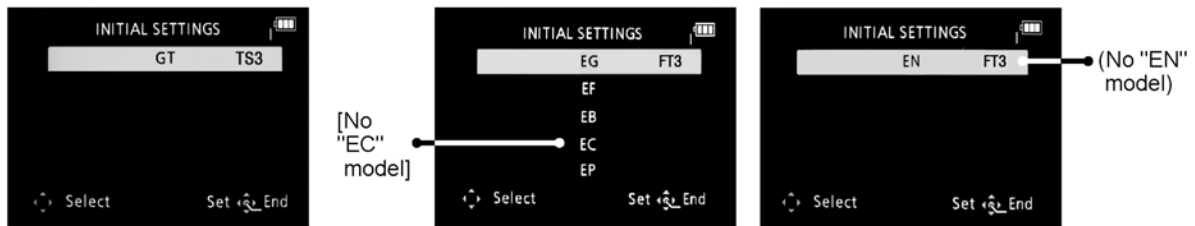

• Step 5. Choose the model suffix in "INITIAL SETTINGS": (Refer to "CAUTION 1")

[Caution: After replacing MAIN P.C.B.]

(Especially, other than "EG, EF, EB and EP" models : (VEP56129B is used as a Main P.C.B.))

The model suffix can be chosen, JUST ONE TIME.

Once one of the model suffix have been chosen, the model suffix lists will not be displayed, thus, it can be changed.

Therefore, select the area carefully.

Select the area with pressing "UP / DOWN of Cursor buttons".

• Step 6. Set the model suffix at "INITIAL SETTINGS":

Press the "RIGHT of Cursor buttons".

The only set area is displayed. Press the "RIGHT of Cursor buttons" after confirmation.

(The unit is powered off automatically.)

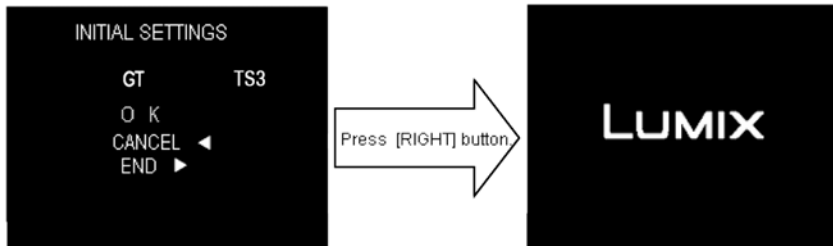

• **Step 7. CONFIRMATION:**

Confirm the display of "PLEASE SET THE CLOCK" in concerned language when the unit is turned on again.

When the unit is connected to PC with USB cable, it is detected as removable media.

1) As for your reference, major default setting condition is as shown in the following table.

Default setting (After "INITIAL SETTINGS")

	MODEL	VIDEO OUTPUT	LANGUAGE	DATE	REMARKS
a)	DMC-FT3(Japan domestic model)	NTSC	Japanese	Year/Month/Date	
b)	DMC-FT3EB	PAL	English	Date/Month/Year	
c)	DMC-FT3EE	PAL	Russian	Date/Month/Year	
d)	DMC-FT3EF	PAL	French	Date/Month/Year	
e)	DMC-FT3EG	PAL	English	Date/Month/Year	
f)	DMC-FT3EP	PAL	English	Date/Month/Year	
g)	DMC-FT3GC	PAL	English	Date/Month/Year	
h)	DMC-FT3GN	PAL	English	Date/Month/Year	
i)	DMC-FT3SG	PAL	English	Date/Month/Year	
j)	DMC-TS3GH	PAL	English	Date/Month/Year	
k)	DMC-TS3GD	NTSC	Korean	Year/Month/Date	
l)	DMC-TS3GT	NTSC	Chinese (Traditional)	Year/Month/Date	
m)	DMC-TS3P	NTSC	English	Date/Month/Year	
n)	DMC-TS3PC	NTSC	English	Date/Month/Year	
o)	DMC-TS3PU	NTSC	Spanish	Date/Month/Year	

4 Specifications

Digital Camera:
Information for your safety

Power Source:	DC 5.1 V	
Power Consumption:	1.4 W (When recording) 0.7 W (When playing back)	
Camera effective pixels	12,100,000 pixels	
Image sensor	1/2.33" CCD, total pixel number 12,500,000 pixels, Primary color filter	
Lens	Optical 4.6× zoom, f=4.9 mm to 22.8 mm (35 mm film camera equivalent: 28 mm to 128 mm)/F3.3 (Wide) to F5.9 (Tele)	
Digital zoom	Max. 4×	
Extended optical zoom	Max. 9.1× (When set to 3,000,000 pixels [3M] or less)	
Focus range	Normal	30 cm (0.99 feet) to ∞
	Macro/ Intelligent auto/ Motion Picture	5 cm (0.17 feet) (Wide)/30 cm (0.99 feet) (Tele) to ∞
	Scene Mode	There may be differences in the above settings.
Shutter system	Electronic shutter+Mechanical shutter	
Burst recording		
Burst speed	Approx. 3.7 pictures/second	
Number of recordable pictures	Max. 7 pictures	
Hi-speed burst		
Burst speed	Approx. 10 pictures/second (Speed priority) Approx. 7 pictures/second (Image priority) 3M (4:3), 2.5M (3:2), 2M (16:9), 2.5M (1:1) is selected as the picture size.	
Number of recordable pictures	When using the built-in memory: Approx. 15 pictures (immediately after formatting) When using a Card: Max. 100 pictures (differs depending on the type of Card and the recording conditions)	
Minimum Illumination	Approx. 12 lx (when i-low light is used, the shutter speed is 1/30th of a second)	
Shutter speed	8 seconds to 1/1300th of a second [Starry Sky] Mode: 15 seconds, 30 seconds, 60 seconds	
Exposure (AE)	Program AE Exposure compensation (1/3 EV Step, -2 EV to +2 EV)	
Metering mode	Multiple	
LCD monitor	2.7" TFT LCD (Approx. 230,000 dots) (field of view ratio about 100%)	
Flash range	Approx. 30 cm (0.99 feet) to 5.6 m (18.4 feet) (Wide, [ISO AUTO] is set)	
Microphone	Monaural	
Speaker	Monaural	
Recording media	Built-in Memory (Approx. 19 MB)/SD Memory Card/ SDHC Memory Card/SDXC Memory Card	
Recording file format		
Still Picture	JPEG (based on "Design rule for Camera File system", based on "Exif 2.3" standard, DPOF corresponding)/ MPO	
Motion pictures with audio	AVCHD/QuickTime Motion JPEG	

Interface	
Digital	"USB 2.0" (High Speed)
Analog video audio	NTSC, Audio line output (monaural)
Terminal	
[AV OUT/DIGITAL]	Dedicated jack (8 pin)
[HDMI]	MicroHDMI TypeD
Dimensions (excluding the projecting parts)	Approx. 103.5 mm (W)×64 mm (H)×26.5 mm (D) [4.07"(W)×2.52"(H)×1.04"(D)]
Mass (weight)	Approx. 197 g/0.434 lb (with card and battery) Approx. 175 g/0.386 lb (excluding card and battery)
Operating temperature	– 10 °C* to 40 °C (14 °F* to 104 °F) * The performance of the battery (number of recordable pictures/operating time) may decrease temporarily when using the camera in a temperature between – 10 °C to 0 °C (14 °F to 32 °F) (at the cold climate such as ski resorts).
Operating humidity	10%RH to 80%RH
Language select	[ENGLISH]/[ESPAÑOL]
Bearing sensor	8 bearing detection (with angular position correction function by the 3 axes acceleration sensor, with automatic declination correction, and with automatic offset adjustment function)
Atmospheric pressure/altitude sensor	
Atmospheric pressure	Measurement range 300 hPa to 1100 hPa, with 24 hour memory function in 1 hPa unit (every 1.5 hours)
Altitude	Convert atmospheric pressure to altitude using International Standard Atmosphere (ISA), accuracy: –5 m (–16.4 feet) to +5 m (16.4 feet)
Depth	Displays in 3 levels (displays 0 m (0 feet) to 12 m (40 feet) in 3 levels)
GPS	Reception frequency: 1575.42 MHz (C/A code) Geographical coordinate system: WGS84
Waterproof performance	Equivalent to IEC 60529 "IPX8". (Usable for 60 minutes in 12 m (40 feet) water depth)
Crash resistance performance	The test method of the camera is in compliance with "MIL-STD 810F Method 516.5-Shock"*. * "MIL-STD 810F Method 516.5-Shock" is the test method standard of the U.S. Defense Department, which specifies performing drop tests from a height of 122 cm (4.0 feet), at 26 orientations (8 corners, 12 ridges, 6 faces) using 5 sets of devices, and passing the 26 orientation drops within 5 devices. (If failure occurs during the test, a new set is used to pass the drop orientation test within a total of 5 devices) • Panasonic's test method is based on the above "MIL-STD 810F Method 516.5-Shock". However, the drop height was changed from 122 cm (4.0 feet) to 200 cm (6.6 feet) dropping onto 3 cm (0.10 feet) thick plywood. This drop test was passed. (Disregarding appearance change such as loss of paint or distortion of the part where drop impact is applied.) There is no guarantee of not breaking or malfunctioning under all conditions.
Dustproof performance	Equivalent to IEC 60529 "IP6X".

Battery Charger (Panasonic DE-A59B):

Information for your safety

Input:	110 V to 240 V ~ 50/60 Hz, 0.2 A
Output:	4.2 V === 0.65 A
Operating temperature:	0 °C* to 40 °C (32 °F* to 104 °F)
	* The battery cannot be recharged in a temperature less than 0 °C (32 °F). (The [CHARGE] indicator blinks when the battery cannot be recharged.)

Equipment mobility: Movable**Battery Pack (lithium-ion) (Panasonic DMW-BCF10PP):**

Information for your safety

Voltage/capacity:	3.6 V/940 mAh
--------------------------	---------------

Note:

*Above specification is for DMC-TS3P. Some of the specification may differ depends on model suffix.

[1] Only for "EB/EF/EG/EP" models:**1). [Interface Digital:]**

- Data from the PC can not be written to the camera using the USB connection cable.

[2] Others:**1). [Analog video/audio:]**

NTSC -----(Only "P/PC/PU/GT/GD" models)

NTSC/PAL Composite (Switched by menu) -----(Except "P/PC/PU/GT/GD" models)

2). [Motion pictures:]

- Maximum time to record motion pictures continuously with [GFS]/[FSH] in [AVCHD] is 29 minutes 59 seconds.
- Motion picture recorded continuously in [Motion JPEG] is up to 2 GB. Only the maximum recordable time for 2 GB is displayed on the screen.

(Important) About the Waterproof/Dustproof and Anti-shock Performance of the Camera

Waterproof/Dustproof Performance

This camera's waterproof/dustproof rating complies with the "IPX8" and "IP6X" ratings. Provided the care and maintenance guidelines described in this document are strictly followed, this camera can operate underwater, to a depth not exceeding 12 m (40 feet) for a time not exceeding 60 minutes. (*1)

Anti-shock Performance

This camera also complies with "MIL-STD 810F Method 516.5-Shock". The camera has cleared a drop test from a height of 2 m (6.6 feet) onto 3 cm (0.10 feet) thick plywood. In most cases this camera should not sustain any damage if dropped from a height not exceeding 2 m (6.6 feet). (*2)

This does not guarantee no destruction, no malfunction, or waterproofing in all conditions.

*1 This means that the camera can be used underwater for specified time in specified pressure in accordance with the handling method established by Panasonic.

*2 "MIL-STD 810F Method 516.5-Shock" is the test method standard of the U.S. Defense Department, which specifies performing drop tests from a height of 122 cm (4.0 feet), at 26 orientations (8 corners, 12 ridges, 6 faces) using 5 sets of devices, and passing the 26 orientation drops within 5 devices. (If failure occurs during the test, a new set is used to pass the drop orientation test within a total of 5 devices)
Panasonic's test method is based on the above "MIL-STD 810F Method 516.5-Shock". However, the drop height was changed from 122 cm (4.0 feet) to 200 cm (6.6 feet) dropping onto 3 cm (0.10 feet) thick plywood. This drop test was passed.
(Disregarding appearance change such as loss of paint or distortion of the part where drop impact is applied.)

■ Handling of the camera

- Waterproofing is not guaranteed if the unit is subject to an impact as a result of being hit or dropped etc. If an impact to the camera occurs, it should be inspected (subject to a fee) by a Panasonic's Service Center to verify that the waterproofing is still effective.
- When the camera is splashed with detergent, soap, hot spring, bath additive, sun oil, sun screen, chemical, etc., wipe it off immediately.
- Waterproof function of the camera is for sea water and fresh water only.
- Any malfunction caused by customer misuse, or mishandling will not be covered by the warranty.
- The inside of this unit is not waterproof. Water leakage will cause malfunction.
- Supplied accessories are not waterproof (excluding strap).
- Card and battery are not waterproof. Do not handle with a wet hand. Also, do not insert wet card or battery into the camera.
- Do not leave the camera for a long period of time in places where temperature is very low (at ski resorts or at high altitude etc.) or very high [above 40 °C (104 °F)], inside a car under strong sunlight, close to a heater, on the beach, etc. Waterproof performance may be degraded.

■ About the [Precautions] demonstration display

- [Precautions] is displayed when the power is turned on for the first time after purchase, with the side door completely closed.
- Please check beforehand to maintain the waterproof performance.

1 Press ◀ to select [Yes], and press [MENU/SET].

- It will automatically skip to the clock setting screen if [No] is selected before it starts.

2 Press ◀/▶ to select the picture.

◀: Return to the previous screen

▶: View the next screen

- It can be forcefully ended by pressing [MENU/SET].
- When it is forcefully ended while checking by turning the power off or pressing [MENU/SET], [Precautions] is displayed every time the power is turned on.

3 After the final screen (12/12), press [MENU/SET] to finish.

- When [MENU/SET] is pressed after the final screen (12/12), [Precautions] is not displayed from the next time the power is turned on.
- This can also be viewed from [Precautions] (P46) in the [Setup] menu.

Check before using underwater

Do not open or close the side door in places with sand and dust, close to water, or with wet hands. Sand or dust adhering may cause water leaks.

1 Check that there are no foreign objects on the inner side of the side door.

- If there is any foreign object, such as lint, hair, sand, etc., on the surrounding area, water will leak within a few seconds causing malfunction.
- Wipe it off with a dry soft cloth if there is any liquid.
It may cause water leaks and malfunction if you use the camera with liquid adhered.
- If there is any foreign material, remove with supplied brush.
- Be extremely careful to remove the small sand etc. that may adhere to the sides and corners of the rubber seal.
- Remove large foreign objects, wet sand, etc., using the shorter (harder) side of the brush.

- (A) Brush (supplied)
- (B) Side door

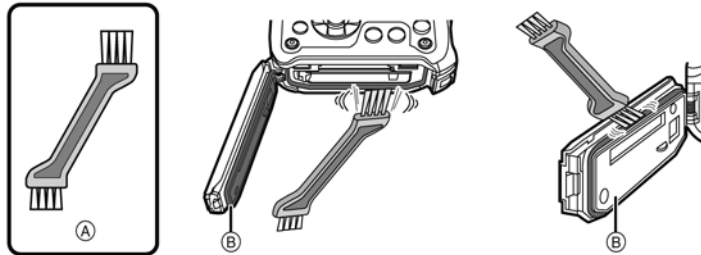

2 Check for cracks and deformation of the rubber seal on the side door.

- The integrity of the rubber seals may decrease after about 1 year, with use and age. To avoid permanently damaging the camera the seals should be replaced once each year. Please contact Panasonic's Service Center for related costs and other information.

3 Close the side door securely.

- Lock the [LOCK] switch securely until the red part is no longer visible.
- To prevent water seeping into the camera, be careful not to trap foreign objects such as liquids, sand, hair or dust etc.

- (C): Red part
- (D): [LOCK] switch (gray part)
- (E): Released state
- (F): Locked state

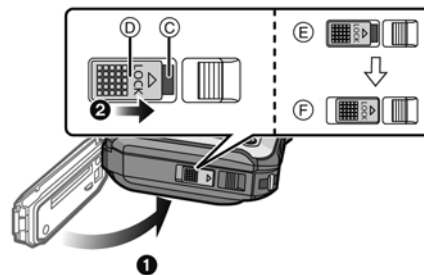

Using the camera underwater

- Use the camera underwater at a depth of up to 12 m (40 feet) with the water temperature between 0 °C and 40 °C (32 °F to 104 °F).
- Do not use for scuba diving (Aqualung).
- Do not use the camera at a depth of over 12 m (40 feet).
- Do not use it in the hot water over 40 °C (104 °F) (in the bath or hot spring).
- Do not use the camera underwater not longer than 60 minutes continuously.
- Do not open or close the side door.
- Do not apply shock to the camera underwater. (Waterproof performance may not be maintained, and there is a chance of water leak.)
- Do not dive into the water holding the camera. Do not use the camera in a location where the water will splash strongly, such as rapid flow or waterfall. (Strong water pressure may be applied, and it may cause malfunction.)
- The camera will sink in the water. Take care not to drop the camera and lose it underwater by securely placing the strap around your wrist or similar measure.

Caring of the camera after using it underwater

Do not open or close the side door until the sand and dust is removed by rinsing the camera with water.

Make sure to clean the camera after using it.

- Thoroughly wipe off any water droplets, sand, and saline matter on your hands, body, hair, etc.
- It is recommended to clean the camera indoors, avoiding places where water spray or sand may fall.

Do not leave the camera uncared for more than 60 minutes after using it underwater.

- Leaving the camera with foreign objects or saline matter on it may cause damage, discoloration, corrosion, unusual odour, or deterioration of the waterproof performance.

1 Rinse with water with the side door closed.

- After use at the seaside or underwater, soak the unit in fresh water pooled in a shallow container for 10 minutes or less.
- If the zoom button or camera [OFF/ON] button do not move smoothly, it may be caused by an adhesion of foreign objects. Using in such a state may cause malfunctions, such as locking up, so wash off any foreign objects by shaking the camera in fresh water.
- Bubbles may come out of the drainage hole when you immerse the camera in water, but this is not a malfunction.



Before Use

2 Drain water by holding the camera upside down and shaking it lightly a few times.

- After using the camera at the seaside or under water, or after washing it, water will remain at the speaker site of the camera for a while and it may cause lower sound or sound distortion.
- Fasten the strap firmly to prevent the camera from dropping.

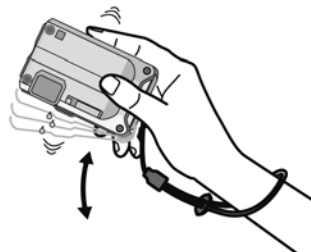

3 Wipe off water drops on the camera with a dry soft cloth and dry the camera in a shaded area which is well ventilated.

- Dry the camera by standing it on a dry cloth. This unit incorporates drain design, draining water in gaps in the camera [OFF/ON] button and zoom button etc.
- Do not dry the camera with hot air from dryer or similar. Waterproof performance will deteriorate due to deformation.
- Do not use chemicals such as benzine, thinner, alcohol, or cleanser, or soap or detergents.



4 Confirm that there are no water droplets, open the side door, and wipe off any water droplets or sand left inside using a soft dry cloth.

- Water droplets may adhere to the card or battery when the side door is opened without thoroughly drying. Also, water may accumulate in the gap around the card/battery compartment or the terminal connector. Be sure to wipe any water off with a soft dry cloth.
- The water droplets may seep into the camera when the side door is closed while it is still wet, causing condensation or failure.

5 Location of Controls and Components

Names of the Components

- 1 Flash
- 2 Self-timer indicator/
AF Assist Lamp/LED light
- 3 Lens

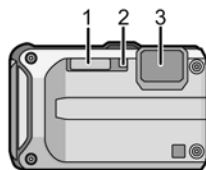

- 4 LCD monitor
- 5 Speaker
- 6 Zoom button
- 7 Playback button
- 8 [MODE] button
- 9 [MENU/SET] button
- 10 [Q.MENU]/Delete/Cancel button
- 11 [DISP.] button

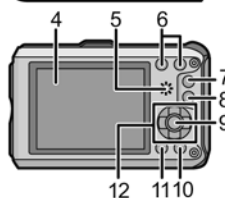

- 12 Cursor buttons
 - (A): ▲/Exposure compensation
Auto Bracket
 - (B): ▼/Macro Mode
AF Tracking
 - (C): ◀/Self-timer
 - (D): ▶/Flash setting

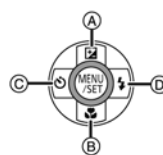

In this Owner's Manual, the cursor buttons are described as shown in the figure below or described with ▲/▼/◀/▶.
e.g.: When you press the ▼ (down) button

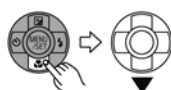

or Press ▼

- 13 Motion picture button
- 14 Shutter button
- 15 Camera [OFF/ON] button
- 16 GPS antenna
- 17 Microphone
- 18 GPS status indicator
- 19 Tripod receptacle

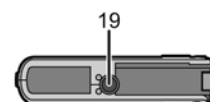
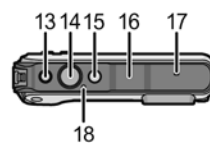

- 20 [HDMI] socket
- 21 [AV OUT/DIGITAL] socket

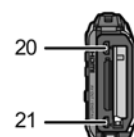



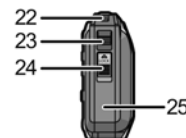

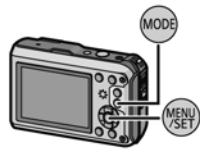

- 22 Strap eyelet
 - Be sure to attach the strap when using the camera to ensure that you will not drop it.
- 23 Release lever
- 24 [LOCK] switch
- 25 Side door



- When using an AC adaptor, ensure that the Panasonic DC coupler (DMW-DCC4; optional) and AC adaptor (DMW-AC5PP; optional) are used.
- Always use a genuine Panasonic AC adaptor (DMW-AC5PP; optional).
- It is recommended to use a fully charged battery or AC adaptor (DMW-AC5PP; optional) and DC coupler (DMW-DCC4; optional) when recording motion pictures.
- If while recording motion pictures using the AC adaptor and the power supply is cut off due to a power outage or if the AC adaptor is disconnected etc., the motion picture being recorded will not be recorded.



■ List of [Rec] Modes

 Normal Picture Mode
The subjects are recorded using your own settings.
 Intelligent Auto Mode
The subjects are recorded using settings automatically selected by the camera.
 Sports Mode
Use this mode to take pictures of sporting events, etc.
 Snow Mode
This allows you to take pictures that show the snow as white as possible at a ski resort or a snow-covered mountain.
 Beach & Snorkeling Mode
This mode is optimal for taking pictures underwater and at the beach.
 Underwater Mode
This is optimal for taking pictures underwater deeper than 12 m (40 feet) by the use of the marine case (DMW-MCFT3; optional)
SCN Scene Mode
This allows you to take pictures that match the scene being recorded.
3D 3D Photo Mode
Takes a 3D picture.

6 Service Mode

6.1. Error Code Memory Function

1. General description

This unit is equipped with history of error code memory function, and can be memorized 16 error codes in sequence from the latest. When the error is occurred more than 16, the oldest error is overwritten in sequence.

The error code is not memorized when the power supply is shut down forcibly (i.e., when the unit is powered on by the battery, the battery is pulled out) The error code is memorized to FLASH ROM when the unit has just before powered off.

2. How to display

The error code can be displayed by ordering the following procedure:

• Preparation:

1. Attach the Battery or AC Adaptor with a DC coupler to the unit.

Note:

- *Since this unit has built-in memory, it can be performed without inserting SD memory card.
- *Select the mode other than "3D" mode (such as normal picture / iA / Sports / Snow / SCN) to display the error code.

• Step 1. The temporary cancellation of "INITIAL SETTINGS":

While keep pressing "UP of Cursor button" and MOTION PICTURE button simultaneously, turn the Power on.

• Step 2. Execute the error code display mode:

Press the "LEFT of Cursor button", MENU/SET button and MOTION PICTURE button simultaneously.

The display is changed as shown below when the above buttons are pressed simultaneously.

Normal display → Error code display → Operation history display → Normal display →

Example of Error Code Display

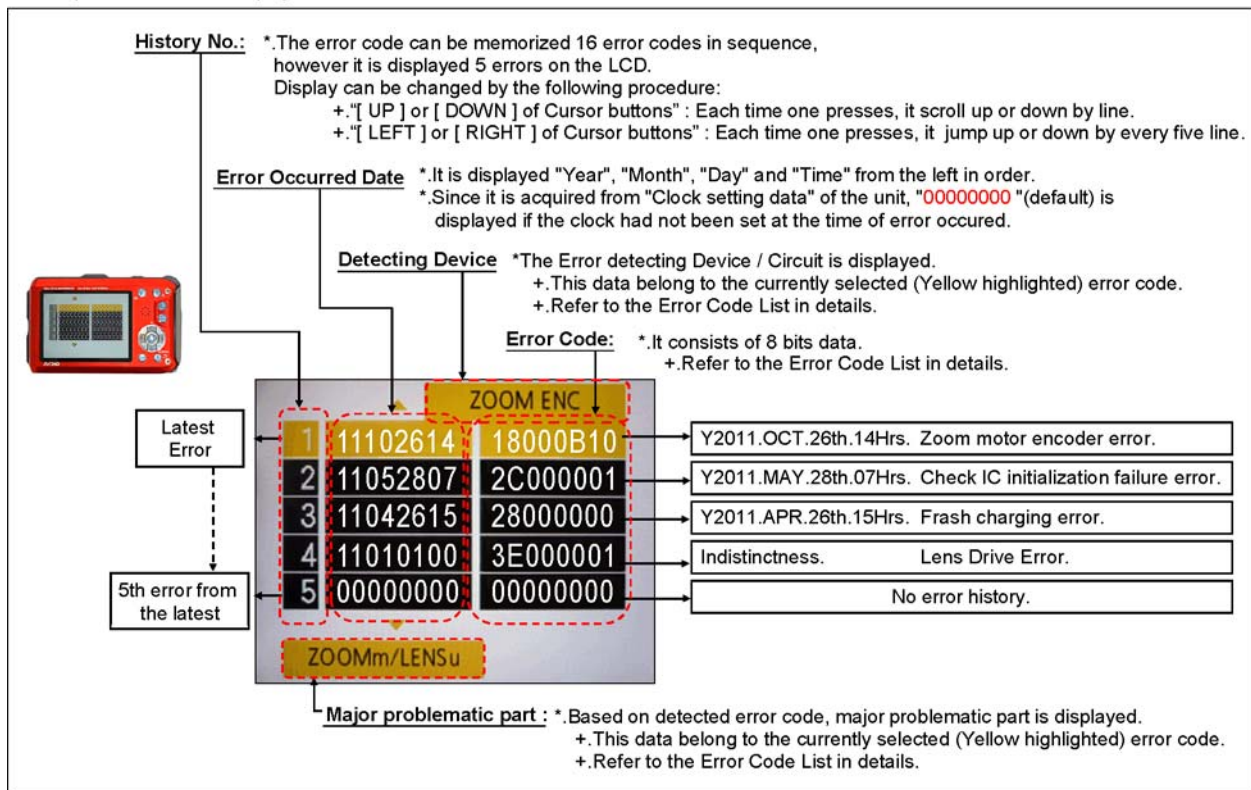

3. Error Code List

The error code consists of 8 bits data and it shows the following information.

Attribute	Main item	Sub item	Error code		Contents (Upper)	Error Indication		
			High 4bits	Low 4 bits	Check point (Lower)	Detecting device	Part/Circuit	
LENS	Lens drive	OIS	18*0	1000	PSD (X) error. Hall element (X axis) position detect error in OIS unit. OIS Unit	OIS X	LENSu NG	
				2000	PSD (Y) error. Hall element (Y axis) position detect error in OIS unit. OIS Unit	OIS Y		
			3000	GYRO (X) error. Gyro (IC6301) detect error on Top P.C.B. IC6301 (Gyro element) or IC6001 (VENUS FHD)	GYRO X	GYRO NG		
				4000	GYRO (Y) error. Gyro (IC6302) detect error on Top P.C.B. IC6302 (Gyro element) or IC6001 (VENUS FHD)		GYRO Y	
			5000	MREF error (Reference voltage error). IC9101 (LENS DRIVE) or IC6001 (VENUS FHD)	OIS REF	LENSSd/DSP NG		
				6000	Drive voltage (X) error. LENS Unit, LENS flex breaks, IC6001(VENUS FHD) AD value error, etc.		OISX REF	LENSu/LENS FPC
			7000	Drive voltage (Y) error. LENS Unit, LENS flex breaks, IC6001(VENUS FHD) AD value error, etc.	OISY REF			
			Zoom	0?10	Collapsible barrel Low detect error (Collapsible barrel encoder always detects Low.) Mechanical lock, FP9002-(40) signal line or IC6001 (VENUS FHD)	ZOOM L	ZOOMm/ LENSu	
					0?20	Collapsible barrel High detect error (Collapsible barrel encoder always detects High.) Mechanical lock, FP9002-(40) signal line or IC6001 (VENUS FHD)		ZOOM H
					0?60	The zoom position jump is detected due to the impact (i.e. drop.) to the camera occurs. Lens unit	(No indication)	(No indication)
			Focus	0?01	HP High detect error (Focus encoder always detects High, and not becomes Low) Mechanical lock, FP9002-(40) signal line or IC6001 (VENUS FHD)	FOCUS L	LENS FPC/ DSP	
					0?02	HP Low detect error (Focus encoder always detects Low, and not becomes High) Mechanical lock, FP9002-(40) signal line or IC6001 (VENUS FHD)		FOCUS H
		Lens	18*1	0000	Power ON time out error. Lens drive system	LENS DRV	LENSu	
				18*2	0000			Power OFF time out error. Lens drive system
		Adj.History	OIS	19*0	2000	OIS adj. Yaw direction amplitude error (small)	OIS ADJ	OIS ADJ
					3000	OIS adj. Pitch direction amplitude error (small)		
					4000	OIS adj. Yaw direction amplitude error (large)		
					5000	OIS adj. Pitch direction amplitude error (large)		
					6000	OIS adj. MREF error		
					7000	OIS adj. time out error		
					8000	OIS adj. Yaw direction off set error		
					9000	OIS adj. Pitch direction off set error		
					A000	OIS adj. Yaw direction gain error		
					B000	OIS adj. Pitch direction gain error		
					C000	OIS adj. Yaw direction position sensor error		
					D000	OIS adj. Pitch direction position sensor error		
					E000	OIS adj. other error		

Attribute	Main item	Sub item	Error code		Contents (Upper)	Error Indication		
			High 4bits	Low 4 bits	Check point (Lower)	Detecting device	Part/Circuit	
HARD	VENUS A/D	Flash	28*0	0000	Flash charging error.	STRB CHG	FLASH P.C.B./FPC	
					IC6001-(AC16) signal line or Flash charging circuit			
	FLASH ROM (EEPROM Area)	FLASH ROM (EEPROM Area)	2B*0	0001 0003 0004	EEPROM read error	FROM RE	FROM	
					IC6002 (FLASH ROM)			
					EEPROM write error	FROM WR	FROM	
					IC6002 (FLASH ROM)			
					0005	Firmware version up error	(No indication)	(No indication)
					0008	Replace the firmware file in the SD memory card.		
0009	SDRAM error							
SYSTEM	RTC	2C*0	0001	SDRAM Mounting defective				
				SYSTEM IC initialize failure error	SYS INIT	MAIN P.C.B.		
SOFT	CPU	Reset	30*0	0001 0007	NMI reset	NMI RST	MAIN P.C.B.	
					Non Mask-able Interrupt (30000001-30000007 are caused by factors)			
	Card	Card	31*0	0001 0002 0004	Card logic error	SD CARD	SD CARD/DSP	
					SD memory card data line or IC6001 (VENUS FHD)			
					Card physical error	SD WRITE	FROM	
					SD memory card data line or IC6001 (VENUS FHD)			
					Write error			
	SD memory card data line or IC6001 (VENUS FHD)							
	39*0	0005	Format error	INMEMORY	FROM			
	CPU, ASIC hard	Stop	38*0	0001 0002 0100 0200 0300	Camera task finish process time out.	LENS COM	LENSu/DSP	
					Communication between Lens system and IC6001 (VENUS FHD)			
					Camera task invalid code error.	DSP	DSP	
					IC6001 (VENUS FHD)			
					File time out error in recording motion image			
					IC6001 (VENUS FHD)			
					File data cue send error in recording motion image			
	IC6001 (VENUS FHD)							
	Single or burst recording brake time out.							
	Memory area	3A*0	0008	USB work area partitioning failure	(No indication)	(No indication)		
				USB dynamic memory securing failure when connecting				
Operation	Power on	3B*0	0000	FLASHROM processing early period of camera during movement.	INIT	(No indication)		
Zoom	Zoom	3C*0	0000	Imperfect zoom lens processing	ZOOM	ZOOMm/LENSu		
				Zoom lens				
				35*0	0000 FFFF	Software error (0-7bit : command, 8-15bit : status)	DSP	DSP
				35*1	0000	Though record preprocessing is necessary, it is not called.		
35*2	0000	Though record preprocessing is necessary, it is not completed.	(No indication)	(No indication)				

1) About "*" indication:

The third digit from the left is different as follows.

In case of 0 (example: 18 0 01000)

When the third digit from the left shows "0", this error occurred under the condition of INITIAL SETTINGS has been completed.

It means that this error is occurred basically at user side.

In case of 8 (example: 18 8 01000)

When the third digit from the left shows "8", this error occurred under the condition of INITIAL SETTINGS has been released.

(Example; Factory assembling-line before unit shipment, Service mode etc.)

It means that this error is occurred at service side.

2) About "?" indication: ("18*0 0?01" to "18*0 0?50"):

The third digit from the right shows one of the hexadecimal ("0" to "F") character.

4. How to returned to Normal Display:

Turn the power off and on, to exit from Error code display mode.

Note:

The error code can not be initialized.

6.2. ICS (Indication of additional Camera Settings when picture was taken) function

1. General description

This unit is equipped with ICS (ICS : Indication of additional Camera Settings when picture was taken) function by playing back the concerned picture on the LCD display.

(This function is achieved by utilizing "maker note" data stored in Exif data area of recorded picture file.)

To proceed failure diagnosis, use this ICS function together with "displaying the recorded picture with picture information" function.

Note:

- *.The ICS function operates with a picture which is only taken with the same model. (It may not be displayed when the picture was taken with other model.)
- *.Since Exif data is not available after the picture is edited by PC, the ICS function may not be activated.

2. How to display

The ICS data is displayed by ordering the following procedure:

• Preparation:

- 1.Attach the Battery or AC Adaptor with a DC coupler to the unit.

Note:

- *Select the mode other than "3D "mode (such as normal picture / iA / Sports / Snow / SCN) to display the ICS data.

• Step 1. The temporary cancellation of "INITIAL SETTINGS":

While keep pressing "UP of Cursor button" and MOTION PICTURE button simultaneously, turn the Power on.

• Step 2. Execute the ICS display mode:

Press the PLAYBACK button.

Select the concerned picture by pressing the "LEFT" and "RIGHT" of Cursor button".

Press the "LEFT" of Cursor button", MENU/SET button and MOTION PICTURE button simultaneously.

Press the DISPLAY button, 3 times.

The display condition is changed as shown below when the DISPLAY button is pressed.

Code display → Code + Picture display (1) → Code + Picture display (2) → ICS display →

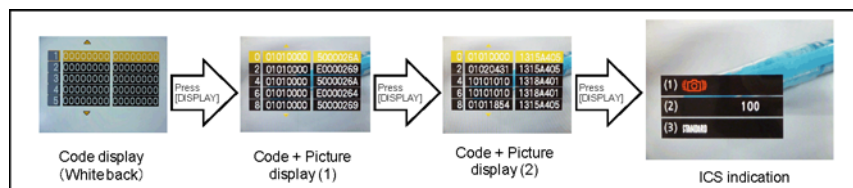

3. How to read

(1). Jitter alert was displayed or not:
 This part shows that the "Jitter alert" mark was displayed or not when the picture has just before been taken.
 +.With "Jitter alert" mark : The "Jitter alert" mark was displayed.
 +.Without "Jitter alert" mark: The "Jitter alert "mark was not displayed.
 [About "Jitter alert" mark]
 Due to lacking the enough light amount etc, shooting condition prone to make a "hand jitter", the "Jitter alert" mark is displayed.
 [Reference Guide]
 (Applicable settings : Normal picture mode, ISO100, WIDE edge, Flash OFF)
 +.The "Jitter alert" mark is displayed when the shutter speed is 1/15th and below.

(2). ISO Sensitivity Setting condition:
 This part shows that the "ISO Sensitivity" setting condition when the picture had been taken.
 (Note: The [i ISO] is displayed when the "Intelligent ISO " was selected.)
 For instance, when the recorded picture information shows [ISO100], it can be confirmed the ISO setting condition ; [AUTO], [INTELLIGENT ISO] or [ISO 100](Fixed: set by user).
 [Point for Confirmation]
 *The symptom is "Picture with "hand jitter". Subject is not clearly stopped." in darker scene, does the picture was taken with lower ISO setting mode?
 *The symptom is "Noisy picture. Rough picture image" in brighter scene, does the picture was taken with higher ISO setting mode?

(3). Color mode Setting condition:
 This part shows that the "Color mode" setting condition when the picture had been taken.
 [Point for Confirmation]
 *The symptom is "Color is strange. The picture is bluish (Yellowish) ", does the picture was taken with [SEPIA] / [COOL] / [WARM] settings?
 NOTE: As for the symptom related with the color, confirm the picture information which is displayed in normal playback screen as well.
 (In normal playback screen, the setting condition of "White balance" and "WB Adjustment" can be confirmed.)

[Reference Guide : Settings "When taking picture"]

<ISO SENSITIVITY>
 *This allows the sensitivity to light (ISO sensitivity) to be set. Setting to a higher figure enables pictures to be taken even in dark places without the resulting pictures coming out dark.
 *In this unit, it can be set one of the [AUTO], [i ISO], [100], [200], [400], [800] and [1600] in "Normal shooting" mode.
 (The ISO sensitivity setting is not available when the [INTELLIGENT ISO] is being used.)
 *When setting to [AUTO], the ISO sensitivity is automatically adjusted to a maximum of [ISO400] according to the brightness.
 (It can be adjusted to a maximum of [ISO1000] when using the flash.)
 *When setting to [iISO], the ISO sensitivity is automatically adjusted to a maximum of [ISO1600].
 *To avoid picture noise, we recommend that you either reduce the ISO sensitivity level or set [COLOR MODE] to [NATURAL], and then take pictures.

	[100] ←	→ [1600]
Recording location (recommended)	When it is light (outdoors)	When it is dark
Shutter speed	Slow	Fast
Noise	Less	Increased
Jitter of the subject	Increased	Less

<COLOR MODE>
 *Using these modes, the pictures can be made sharper or softer, the colors of the pictures can be turned into sepia colors or other color effects can be achieved.
 *In this unit, it can be set one of the following effects in "Normal shooting" mode.

[STANDARD] : This is the standard setting.	[B/W] : The picture becomes black and white.
[NATURAL] : The picture becomes softer.	[SEPIA] : The picture becomes sepia.
[VIVID] : The picture becomes sharper.	[COOL] : The picture becomes bluish.
	[WARM] : The picture becomes reddish.

NOTE: You cannot set [NATURAL], [VIVID], [COOL] or [WARM] in Intelligent auto mode.
 *When you take pictures in dark places, noise may become visible. To avoid noise, we recommend setting to [NATURAL].

Normal playback screen
 (Recorded picture with information)



*In playback mode, the picture information is displayed when pressing the [DISPLAY] button. (It can be confirmed at user as well.)
 *Use this indication together with ICS function.

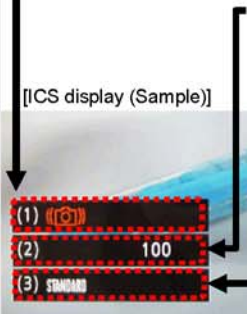

[ICS display (Sample)]

(1) Jitter alert mark : [Indicated]
 (2) ISO sens. setting: ISO100 (Fixed)
 (3) Color mode setting: Standard

4. How to exit

Simply, turn the power off. (Since ICS function is executed under the condition of temporary cancellation of "INITIAL SETTINGS", it wake up with normal condition when turn off the power.)

7 Troubleshooting Guide

7.1. Service and Check Procedures

7.1.1. Servicing flow

- The following is the servicing procedure including assembly/disassembly process.
- As for the air-leak test, refer to "7.2. Air-leak Test".

< Note >

Air-leak test (inspection) before taking service measure:

- When the first inspection, do not perform cleaning (removal of foreign objects caught etc.) of the waterproof packing parts (battery door and Jack door) from the viewpoint of the cause investigation at NG of test (inspection) result.
- When the test (inspection) result was NG, perform test again after cleaning of waterproof packing parts.

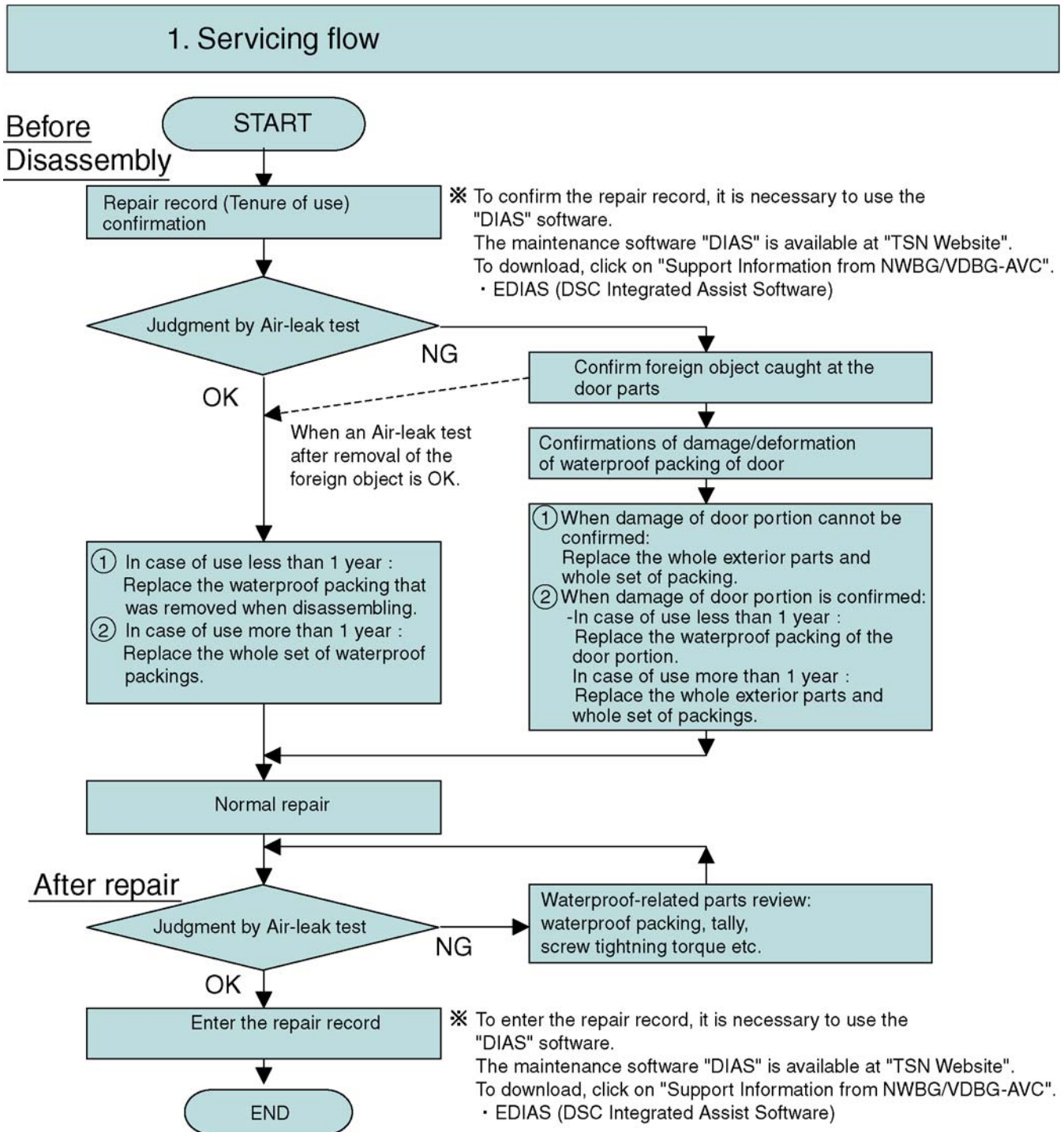

7.1.2. Periodical maintenance (Packing replacement) flow

- The integrity of the waterproof packings may decrease about 1 year, with use and age.
(We recommend end-users to replace the waterproof packing at least once each year described in the operating instructions.)
- Please use waterproof packing kit (Part No.: VUMG1980). (4 types, 8 packings in total are included)
- Do not touch the waterproof packings directly by the hand.
- Do not perform cleaning of waterproof packings by the solvent of alcohol etc. or by blowing air.
- Take care not to put any foreign objects (garbage and dust).
- As for the air-leak test, refer to "7.2. Air-leak Test".

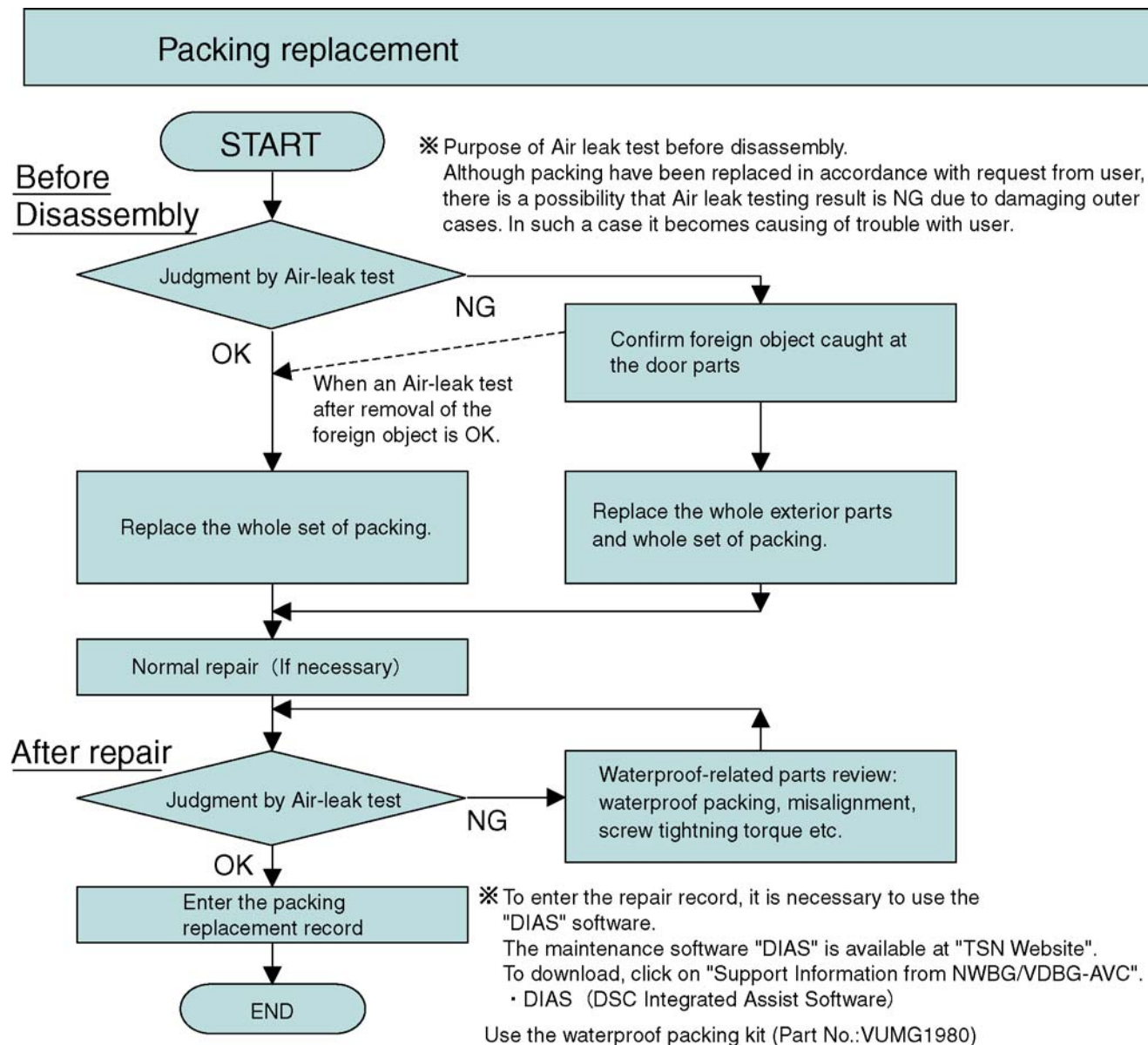

Replacing the waterproof packing

- The location of waterproof packing are shown at right. (4 types, 8 packings in total)
- Waterproof packings are supplied as Waterproof packing kit (Part No.: VUMG1980).

< Note for replacement >

- Do not touch the waterproof packings directly by the hand.
- Do not perform cleaning of waterproof packings by the solvent of alcohol etc. or by blowing air.
- Take care not to put any foreign objects (garbage and dust).
- Use the silicon chips (Prt No.: RFKZ0478) when replacing the Case O-ring.

From Ref No. "P-1" to "P-8" are supplied only as a "waterproof packing kit" (Part No. VUMG1980)

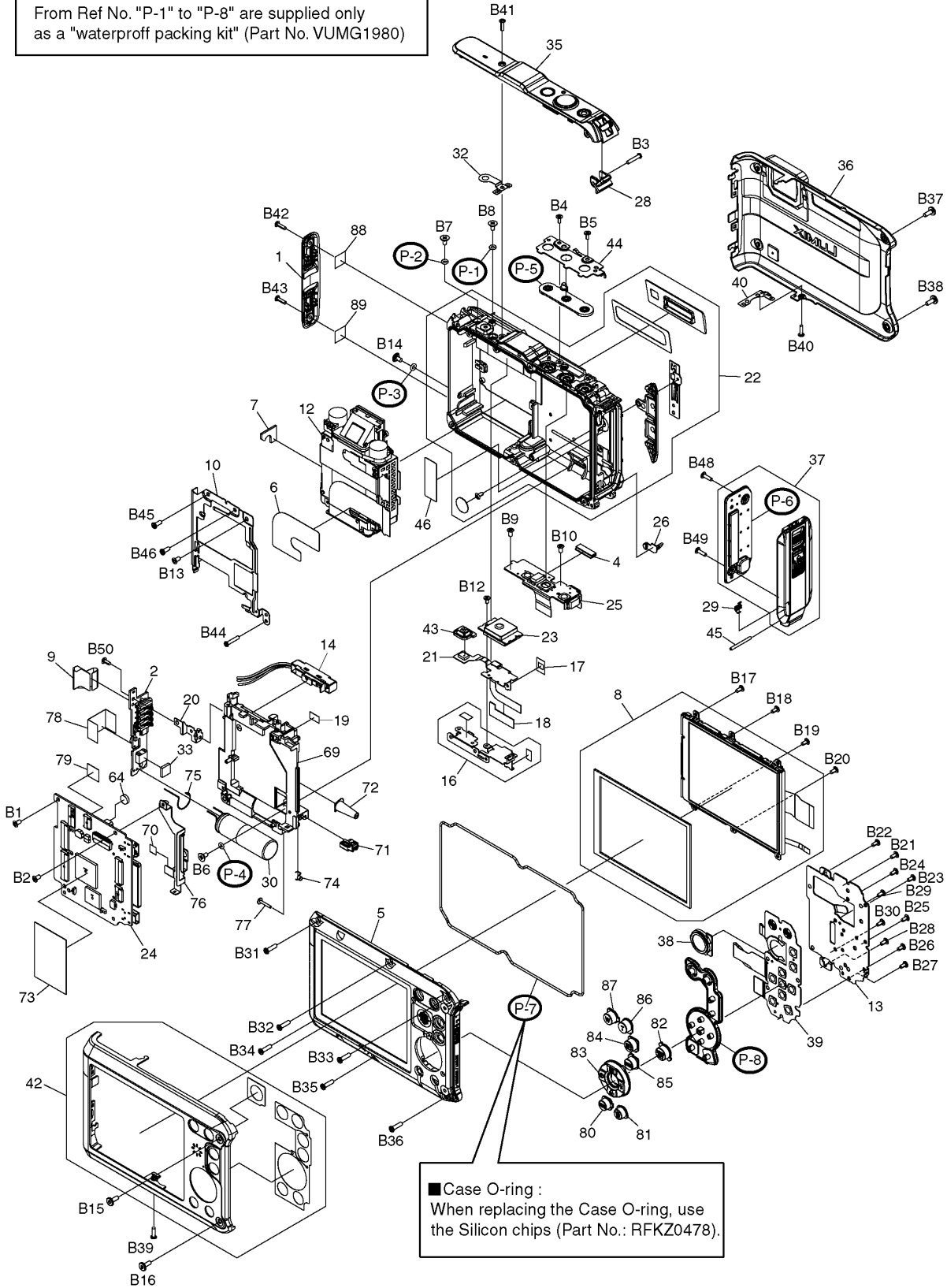

7.2. Air-leak Test

Due to the waterproof performance retention, perform the air-leak test using Air-leak tester (Part No.:RFKZ0528) before/after servicing when disassembling and assembling the unit.

*The Air-leak test before servicing is necessary to be performed to check whether the malfunction occurred due to air-leak or not.

1. Preparation:

- 1) By referring the "9.3. Disassembly procedures", remove the side ornament (R) and front aluminum case.
- 2) Confirm that no fireign objects at the side door, and it is firmly closed.



2. Air-leak Test (Inspection):

*Perform the air-leak test by referring the following procedure.

Note:

As for the detail instruction of air-leak tester, refer to the operating guide (attached to the product).

[Preparation]

1. Put the camera with the top case facing upward condition.
2. Set the following measurement pressure value on the air-leak tester. (Part No.:RFKZ0528).

[Measurement pressure value] :- 33 kPa

*About the Setting methods, refer to the operating guide for air-leak tester.

3. Attach "L" size of absorption pad to the tip of the hose of the air-leak tester.
4. Put the absorption pad of air-leak tester vertically on the inspection point located on the "front case unit".

Note:

- **Keep firmly hold above condition until the measurement is completed.**
- **Once pad is tilted/misaligned from the test hole during testing process, start it from this step.**

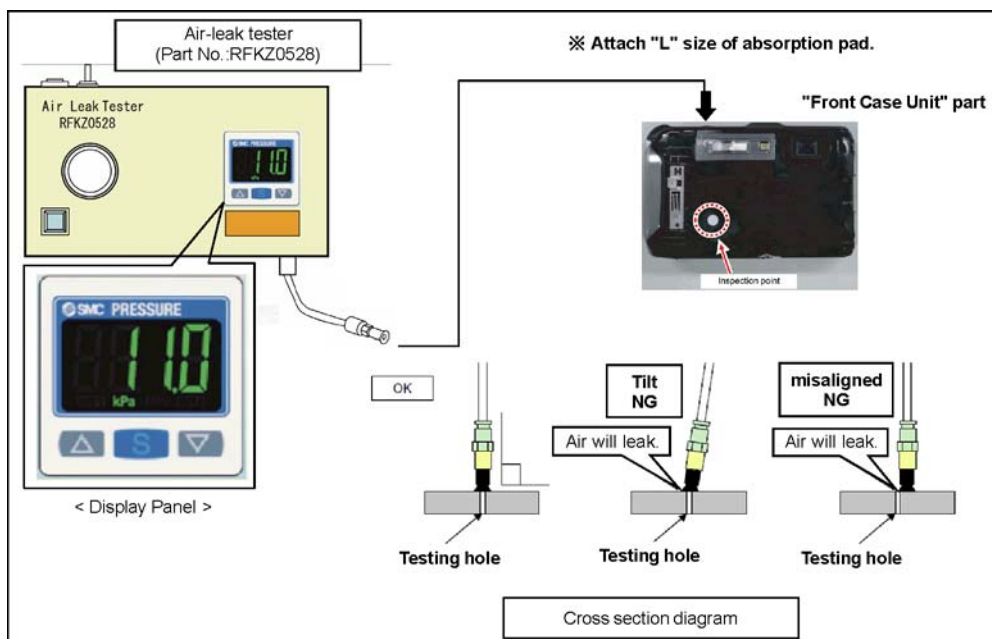

nMeasuring condition (For DMC-FT3, DMC-TS3)

Item	Specifications	Remarks
Setting pressure	- 33 kPa	
Setting stand value	- 30 kPa	
Exhausted period	60sec.	
Stand-by period	15sec.	
Measuring time (Period)	30sec.	
Testing Specification	$\pm 0.2 \text{ kPa}$	(Pressure variation during the measuring period.)

*Attach "L" size of absorption pad.

[Exhaust Air]

5. Operate the measurement switch of the air-leak tester to exhaust air inside the product for 60 seconds.

[Stand-by]

6. After a laps of 15 seconds, take a note (Record) that the pressure value indicated on the indication panel.

[Measurement]

7. Confirm that the pressure value fluctuations during measurement process are within the test specifications

[Measuring time] : 30 seconds
 [Testing Specification] :- 30 kPa \pm 0.2 kPa

The air-leak test is now completed.

3. Packing replacement record input:

- To enter the repair record, it is necessary to use the "DIAS" software. The maintenance software "DIAS" is available at "TSN Website".
 To download, click on "Support Information from NWBG/VDBG-AVC".
 *DIAS (DSC Integrated Assist Software)

7.3. Checking Method of GPS failure

1. GENERAL DESCRIPTION

About the location name information of this unit

Before using the camera, read "User License Agreement for Location Name Data".

When [GPS Setting] is set to [ON], GPS function will operate even when the power is turned off.

- Electromagnetic waves etc. from this unit may affect other electronic devices, so set [GPS Setting] to [OFF] or [GPS] and turn the power of the unit off during plane takeoff or landing, or in an area where use is prohibited.
- Battery power is consumed even if the power is turned off when [GPS Setting] is set to [ON].

About the information of recording location

- Location names of the recording locations or landmarks (such as name of the building etc.) are as of December 2010. Information will not be updated.
- Depending on the country or the region, there may be less information for location names and landmark names.

About the positioning

- It will take longer for positioning in an environment where it is harder to receive the radio waves from the GPS satellites.
- **Even if the receiving condition of the radio waves is excellent, it may take 2 to 3 minutes to complete the positioning when performing positioning for the first time or when you perform positioning after turning on the power again after turning the power off with the [GPS Setting] set to [GPS] or [OFF].**
- The positions of the GPS satellites are changing constantly, so positioning may not be performed or the information may have errors depending on the recording location or conditions.

When used during overseas travel etc.

- The GPS may not operate in China or close to the Chinese border in neighbouring countries. (As of December 2010)
- The usage of GPS, etc., may be restricted depending on the country or the region. This camera has a GPS function, so check with the embassies or travel agencies etc. prior to your overseas travel regarding any restrictions on cameras with a built-in GPS function.

2. Checking flowchart of GPS failure.

The checking flowchart of GPS failure is as follows:

Note:

*Perform the GPS communication test, even if the repair being carried out is not related with GPS function.

*The GPS function in this unit is performed communication between GPS module (Mic GPS FPC Unit) and VENUS (IC6001: on the MAIN P.C.B.).

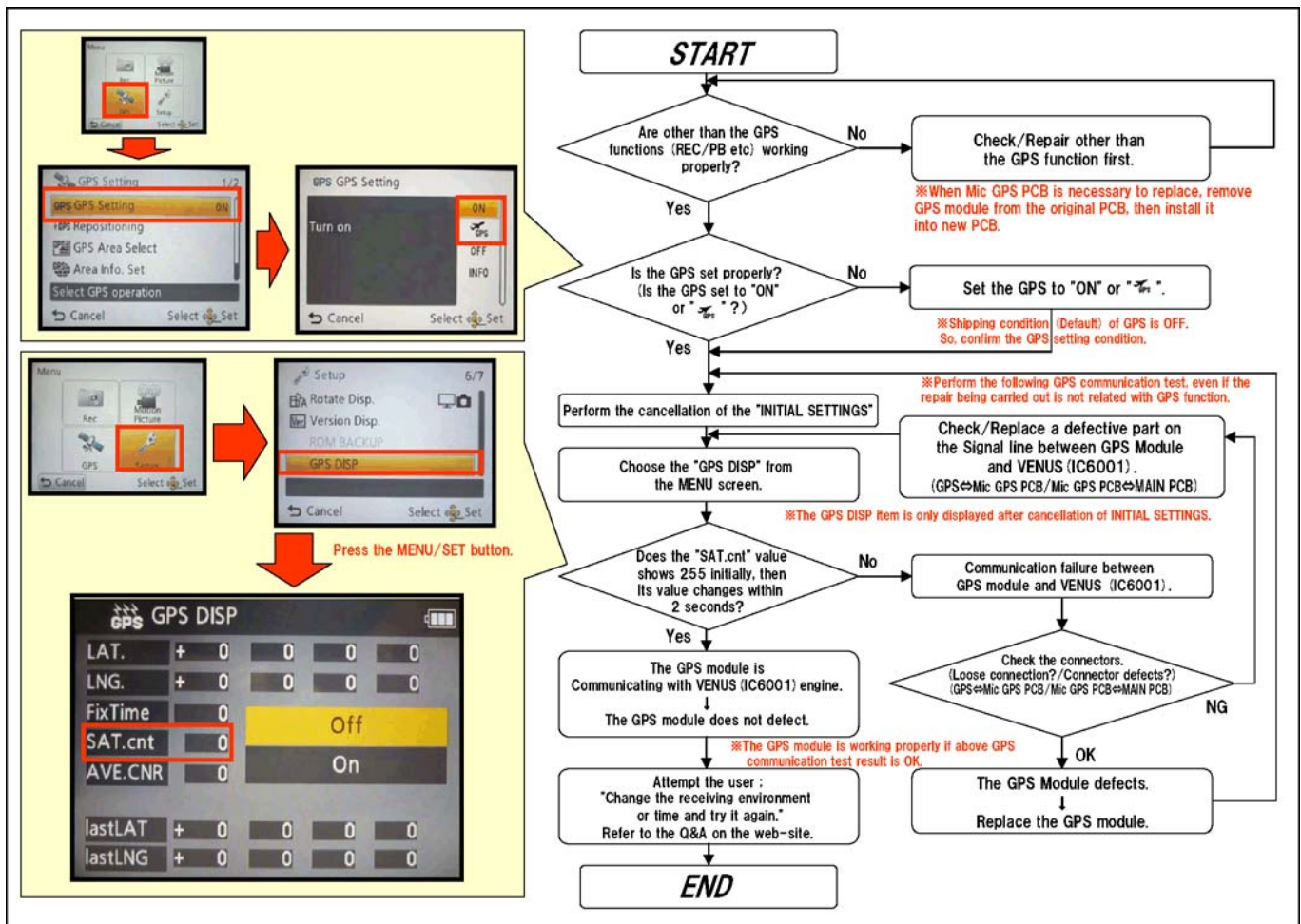

7.4. Checking Method of compass, altimeter, & barometer

1. GENERAL DESCRIPTION

This unit is possible to display or store in recorded pictures the environmental information of the recording location utilizing the built-in compass, altimeter, and barometer. (To display the compass, altimeter, and barometer, set [GPS Setting] to [ON] or [GPS icon].)

- (A) Compass
- (B) Altimeter
- (C) Latitude
- (D) Longitude
- (E) Time positioning was performed
- (F) Barometer

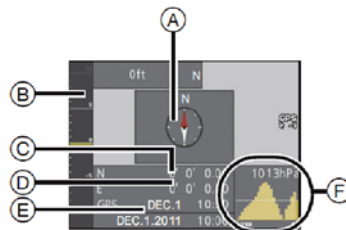

2. ABOUT EACH SENSOR

2.1. COMPASS

2.1.1. General description

- 8 bearings are measured based on the direction the lens of the camera is pointing in.
- Direction of the colored part of the compass needle is north (A).

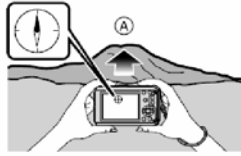

About the declination adjustment

Earth is a giant magnet with the S-pole at the North Pole and the N-pole at the South Pole, and the magnetism the Earth has is called "geomagnetism". There is a difference between the angle of the north that a magnetic compass points to and the geographical "true north" due to the effect of the "geomagnetism". The difference between these angles is called "declination".

The compass in this unit will point to "true north" by automatically correcting the "declination" with a built-in magnetic sensor.

- The declination adjustment of this unit is performed by the latitude/longitude information acquired by the positioning of the GPS. It is recommended to update the current latitude/longitude by frequently performing the positioning since there may be a significant difference in declination due to traveling depending on the location.

Note

- It may not measure correctly when you measure with this unit upside down.
- The bearing measurement value may be affected in locations with weak geomagnetism.
- It may not measure accurately if close to the following objects:
 - Permanent magnets (metals in magnetic necklaces, etc.)/metallic objects (steel desks, lockers, etc.)/high-voltage lines or overhead wires/household appliances (TVs, PCs, speakers, etc.)
- It may not measure accurately in the following locations:
 - Inside cars/trains/ships/aeroplanes/rooms (when the steel beams are magnetized)

2.1.2. Failure diagnosis of Compass.

The Compass sensor unit is IC9301 which is located on TOP FPC unit.

Since the IC9301 does not supply as a spare parts, replace as a TOP FPC unit if necessary.

Settings/Condition:

1. Release the initial settings to be forcefully turned off the declination adjustment:
2. Turn on the GPS setting.
3. Press the Display button to display the compass, altimeter, & barometer.
4. Select [Calibrate compass] from [GPS/Sensor] menu.
5. Securely hold the unit vertically, and adjust by turning it in a figure 8 a few times rolling your wrist.



The "Calibration successful" is displayed when the adjustment is successful.

Diagnosis:

1. When both of the red arrow of compass unit and camera unit's one point same direction, the built-in compass unit works fine.

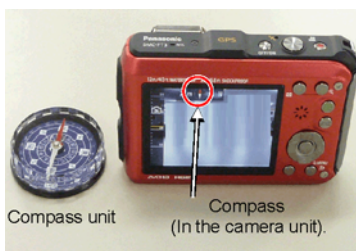

2.2. ALTIMETER

2.2.1. General description

You can check the altitude of the current location.

- Displaying range is -600 m (-2000 feet) to 9000 m (30000 feet).
- There are the following 2 ways to display altitude value:
 - Sea level altitude (absolute altitude from sea level)
 - Relative altitude (difference of altitude between two places)

The altitude value displayed on this unit employs relative altitude. Displayed relative altitude is estimated by a method which uses the relationship between the altitude and atmospheric pressure in the "ISA (International Standard Atmosphere)" specified by the "ICAO (International Civil Aviation Organization)".

2.2.2. Failure diagnosis of Altimeter.

The Altimeter sensor unit is IC9202 which is located on MAIN PCB.

(It detects direction of gravitation.)

Settings/Condition:

1. After performing the compass failure diagnosis, face down (the LCD side up) the camera unit, gradually.

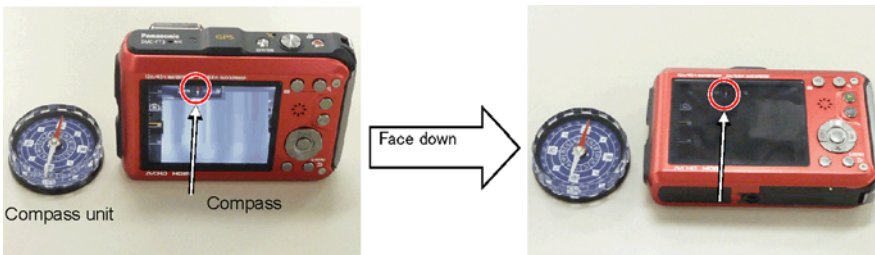

Diagnosis:

1. When the compass in the camera unit points same direction before and after above condition, the built-in altimeter unit works fine.

2.3. BAROMETER

2.3.1. General description

This can be used as a rough indication to understand the trend of weather change during mountain climbing or camping, etc. With the most current atmospheric pressure as a reference, it is displayed on the graph within the range of -10 hPa⁺ to +10 hPa⁺. (Atmospheric pressure out of range cannot be displayed in details)

- Ⓐ Current atmospheric pressure information
 - Ⓑ Atmospheric pressure information in 90 minute intervals
 - Ⓒ Atmospheric pressure information 24 hours ago
- * hPa (hectopascal) is a unit used to represent atmospheric pressure.

- Atmospheric pressure changes in accordance with the movement of the atmosphere.
 - When the atmospheric pressure rises: Weather tends to recover
 - When the atmospheric pressure drops: Weather tends to worsen
- If you leave the [GPS Setting] set to [ON], the atmospheric pressure will be measured even when the power is off.

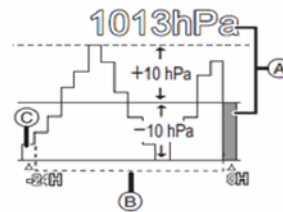

■ About the measured altitude and atmospheric pressure

- Altitude value may show errors depending on the change in atmospheric pressure compared to areas such as locations with altimeter reference signs. Adjust frequently with [Altimeter Adjust].
 - Altitude announced onboard an airplane is measured using the atmospheric pressure surrounding the airplane. It does not match the altitude actually measured inside the airplane.
 - Even if the unit is fixed at a constant altitude, the measured altitude may fluctuate due to the effects of change in atmospheric pressure.
 - Altitude and atmospheric pressure may not be measured accurately in the following cases:
 - When there is a significant change in weather conditions
 - When there is a movement with a rapid change in altitude
 - When this unit is wet (after using underwater, etc.)⁺²
 - When pressure is applied to the front or rear of this unit^{*1}
 - When closing the side door⁺²
- *1 Hold this unit as shown in the figure when measuring.
- *2 It will adapt to the ambient atmospheric pressure within a few minutes, and display correct measurement values.



2.3.2. Failure diagnosis of Barometer.

The barometer sensor unit is IC9201 which is located on MAIN PCB.

Settings/Condition:

1. After performing the altimeter failure diagnosis, take a note that the altimeter which is currently indicated on the LCD.

Diagnosis:

1. Do not turn off the power, but simply open the side door.

In this case, the altimeter value is increased.

2. Close the side door again.









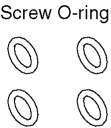

In this case, the altimeter value is decreased.

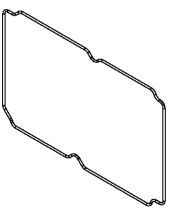
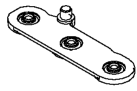
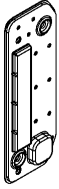
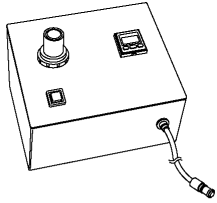
After a while the value becomes closer to original value, the built-in barometer unit works fine.

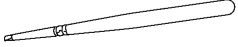
8 Service Fixture & Tools

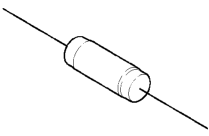
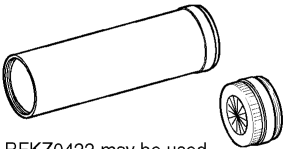
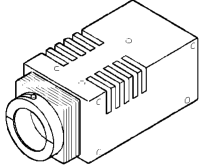
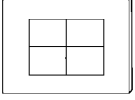
8.1. Service Fixture and Tools

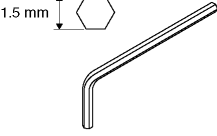
The following Service Fixture and tools are used for checking and servicing this unit.

Related to waterproof				
Waterproof packing kit (For waterproof packing replacement) VUMG1980				
 <p>Screw O-ring</p>	 <p>Rear Button Packing</p>	 <p>Case O-ring</p>	 <p>Top Button Packing</p>	
		 <p>Battery Door Packing</p>		
Air-leak test jig (For Waterproof property test) RFKZ0528				
	Part No.	Usage	Spec.	Remarks
	RFKZ0536	DC/banana conversion cable	For power supply	Optional goods (1 piece supplied with RFKZ0528)
	RFKZ0533	Vacuum pad (2 included)	For power supply	Optional goods (1 piece supplied with RFKZ0528)
	RFKZ0537	Air-leak test tube (without pad)	For air-leak test	Optional goods (1 piece supplied with RFKZ0528)
Torque driver RFKZ0542	Silicon chips RFKZ0478	COMPASS (Please purchase it, locally)		
 <p>(For tightening screws with the torque) RFKZ0456 (Shorter shank version) may be used.</p>	 <p>(For replacing the packings/ For prevention sticking of dust when replacing the packings)</p>			
Resistor for Discharging (1k Ω /5W) ERG5SJ102	Infinity Lens (Built-in Focus Chart) VFK1164TCM02	LIGHT BOX (with DC Cable) VFK1164TDVLB		
 <p>An equivalent type of Resistor may be used.</p>	 <p>※ RFKZ0422 may be used. ※ VFK1164TCM03 may be used.</p>	 <p>※ RFKZ0523 may be used.</p>		
TR Chart RFKZ0443	Lens Cleaning Kit VFK1900BK	Hex Wrench (Please purchase it, locally)		
		 <p>1.5 mm</p>		
ND Filter VFK1164ND15				
				

8.2. When Replacing the Main P.C.B.

After replacing the MAIN P.C.B., be sure to achieve adjustment.

The Maintenance software (DIAS) is available at "software download" on the "Support Information from NWBG/VDBG-AVC" web-site in "TSN system".

8.3. Service Position

This Service Position is used for checking and replacing parts. Use the following Extension cables for servicing.

Table S1 Extension Cable List

No.	Parts No.	Connection	Form
1	RFKZ0549	FP9006 (Main P.C.B.) - FP8001 (Flash P.C.B.)	18PIN 0.5 FFC

8.3.1. Extension Cable Connections

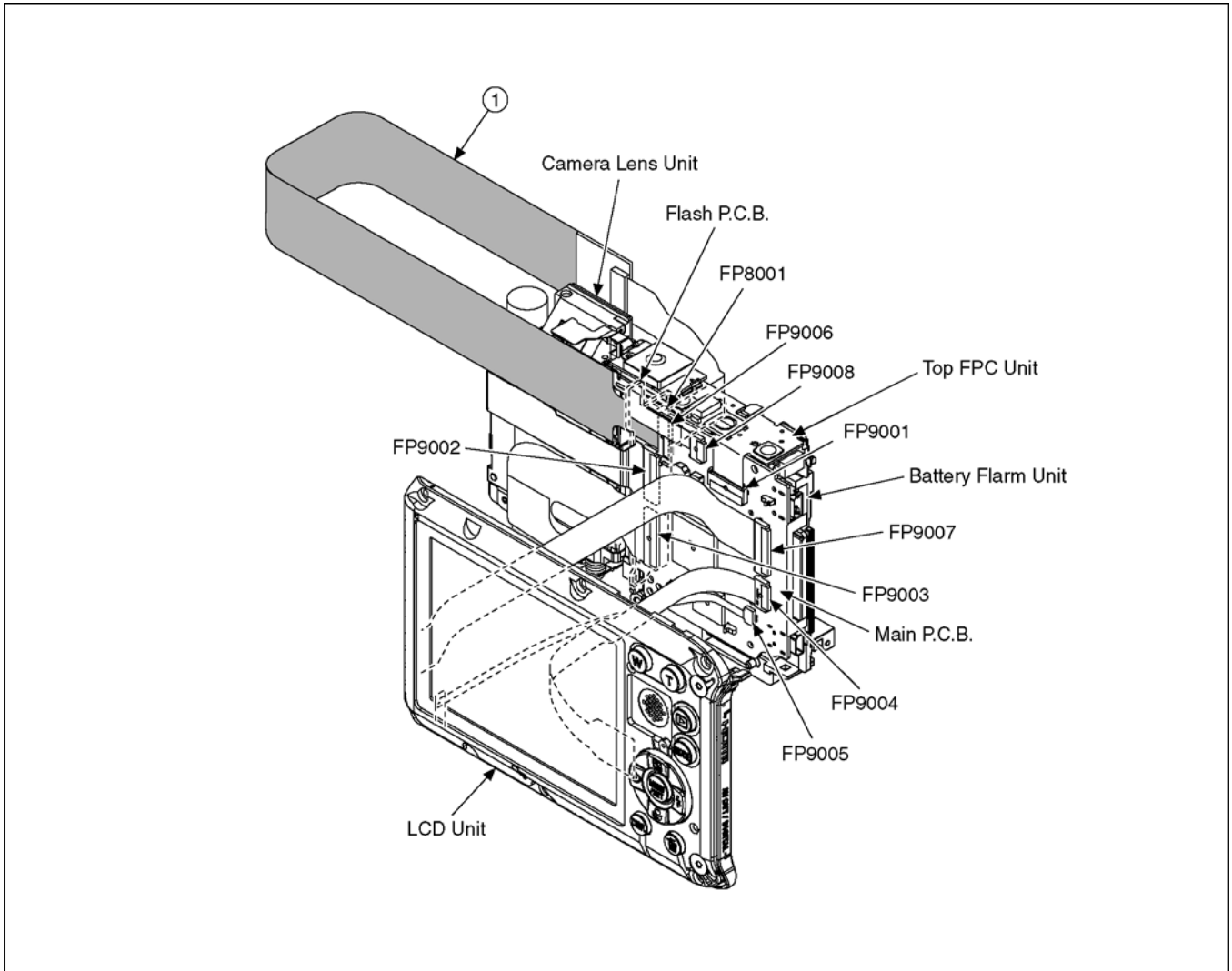

CAUTION-1. (When servicing FLASH P.C.B.)

1. Be sure to discharge the capacitor on FLASH P.C.B.

Refer to "HOW TO DISCHARGE THE CAPACITOR ON FLASH P.C.B.".

The capacitor voltage is not lowered soon even if the AC Cord is unplugged or the battery is removed.

2. Be careful of the high voltage circuit on FLASH P.C.B.
3. DO NOT allow other parts to touch the high voltage circuit on FLASH P.C.B.

9 Disassembly and Assembly Instructions

9.1. Disassembly Flow Chart

- Make sure to perform air-leak test (refer to "7.1. Service and Check Procedures" before disassembly and after assembly for check of waterproof property.
- Do not touch the waterproof packings directly by the hand.
- Do not perform cleaning of waterproof packings by the solvent of alcohol etc. or by blowing air .
- Take care not to put any foreign object (garbage and dust).
- When replacing the case O-ring, use Silicon chips (RFKZ0478).
- When tightening screws, follow the specifications when the torque is specified .

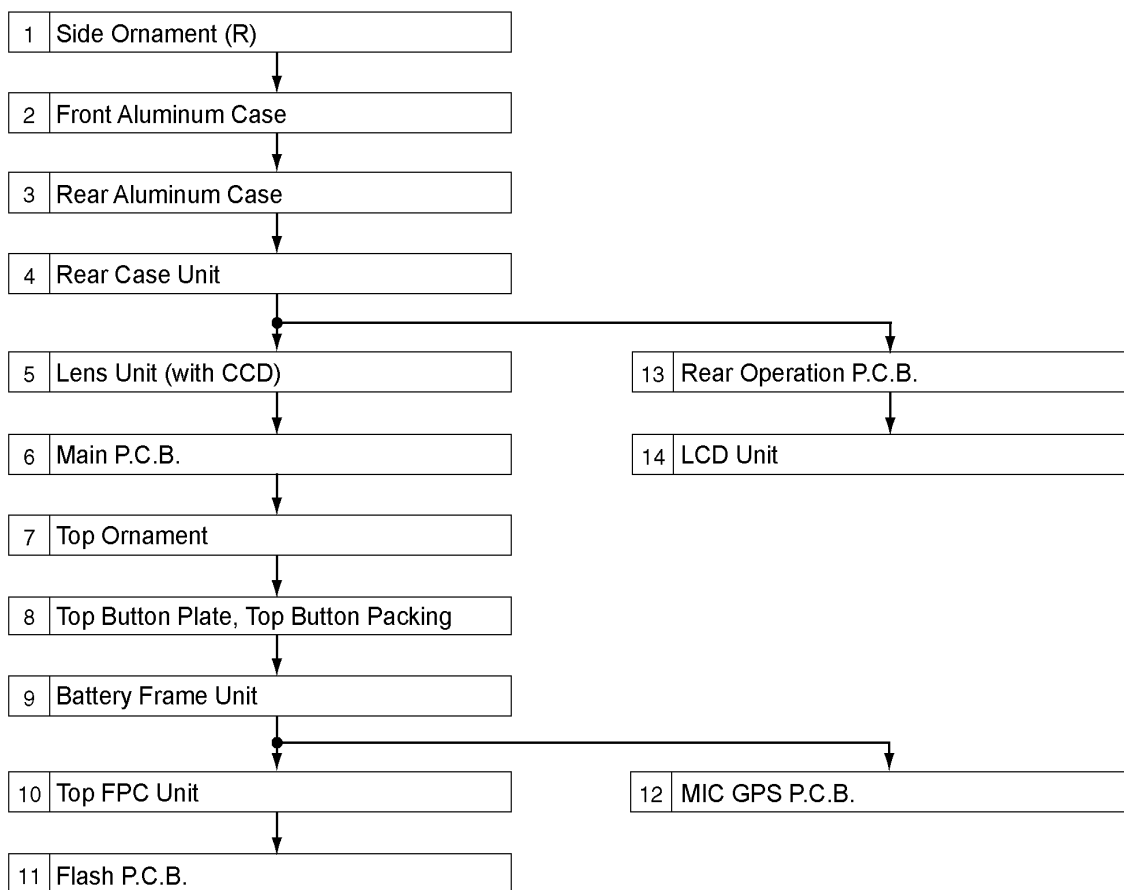

9.2. P.C.B. Location

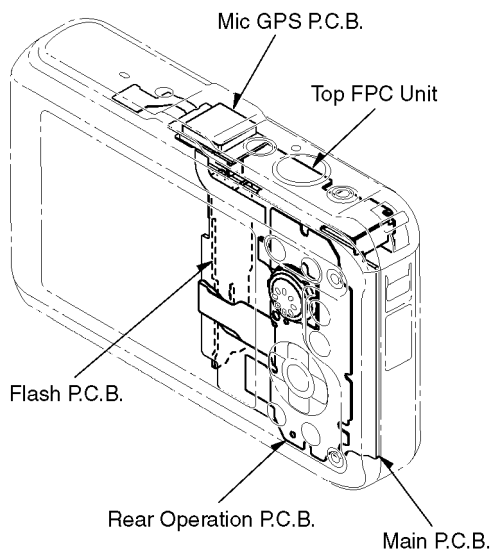

9.3. Disassembly Procedures

9.3.1. Removal of Side Ornament (R)

No.	Item	Fig.	Removal
1	Side Ornament (R)	Fig.D1	SD Card Battery 2 Screws (A) Side Ornament (R)
2	Front Aluminum Case	Fig.D2	2 Hex. Screws (B) 2 Screws (C) Front Aluminum Case
3	Rear Aluminum Case	Fig.D3	2 Hex. Screws (D) 1 Screw (E) Rear Aluminum Case
4	Rear Case Unit	Fig.D4 Fig.D5	6 Screws (F) FP9004 (Flex) FP9005 (Flex) FP9007 (Flex) Rear Case Unit
5	Lens Unit (with CCD)	Fig.D6	1 Screw (G) 2 Screws (H) 1 Screw (I) 1 Screw (J) FP9002 (Flex) FP9003 (Flex) 1 Screw O-ring Lens Plate Camera Lens Unit
6	Main P.C.B.	Fig.D7	2 Screws (K) FP9001 (Flex) FP9006 (Flex) FP9008 (Flex) Main P.C.B.
7	Top Ornament	Fig.D8	1 Screw (L) 1 Locking tab (A) 1 Locking tab (B) Top Earth Plate Top Ornament
8	Top Button Plate/Top Button Packing	Fig.D9	2 Screws (M) Top Button Plate Top Button Packing Front Case Unit
9	Battery Frame Unit	Fig.D10	1 Screw (N) 1 Screw O-ring Battery Frame Unit Front Case Unit
10	Top FPC Unit	Fig.D11	2 Screws (O) Top FPC Unit
11	Flash P.C.B.	Fig.D12	1 Screw (P) 2 Locking tabs FL Earth Plate Flash P.C.B.
12	MIC GPS P.C.B.	Fig.D13	2 Screws (Q) 1 Screw (R) 2 Screw O-rings MIC GPS P.C.B.
13	Rear Operation P.C.B.	Fig.D14 Fig.D15	10 Screws (S) Rear FPC Plate Rear Operation P.C.B. Rear Button Unit
14	LCD Unit	Fig.D16	4 Screws (T) LCD Unit

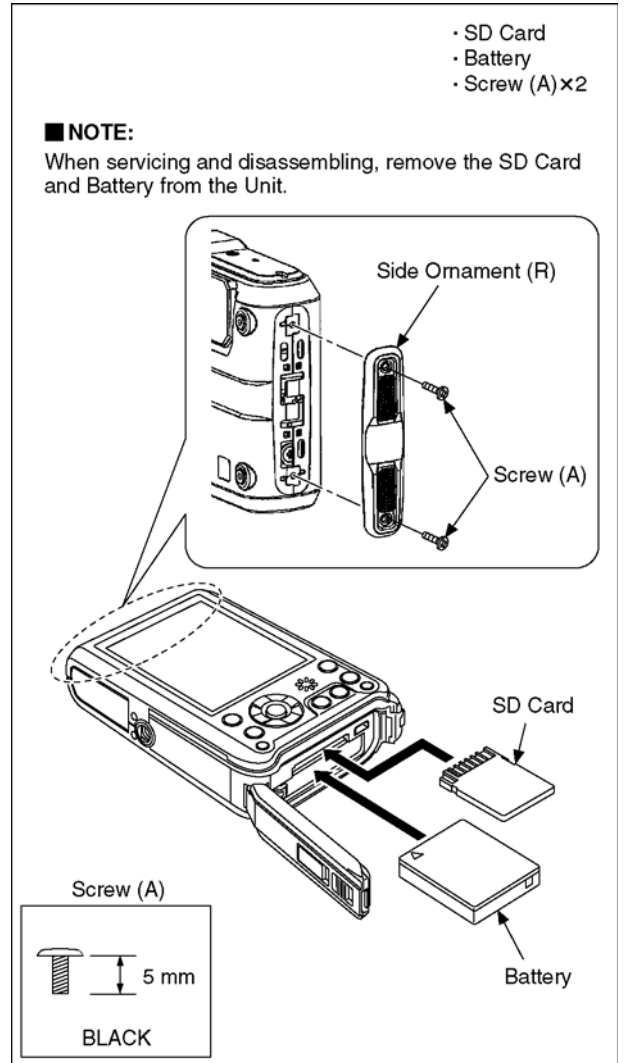

Fig. D1

9.3.2. Removal of Front Aluminum Case

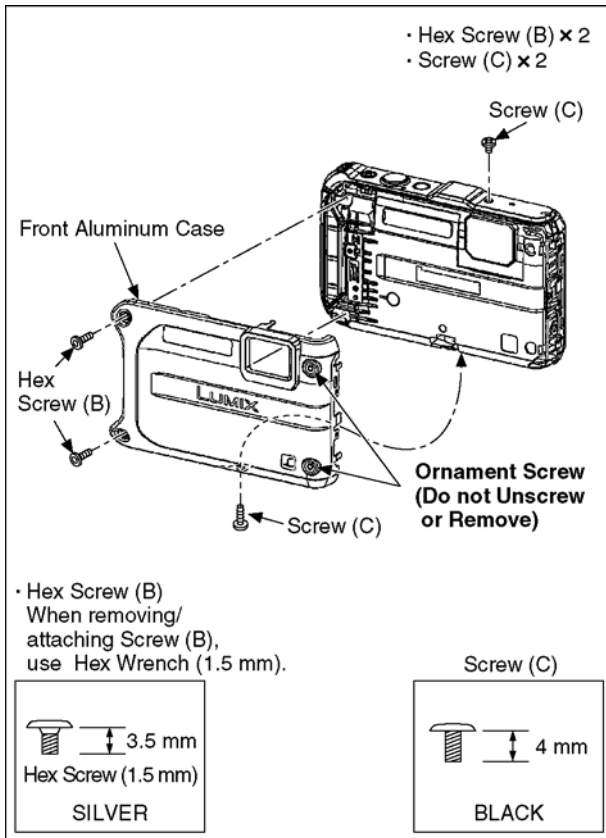

Fig. D2

9.3.3. Removal of Rear Aluminum Case

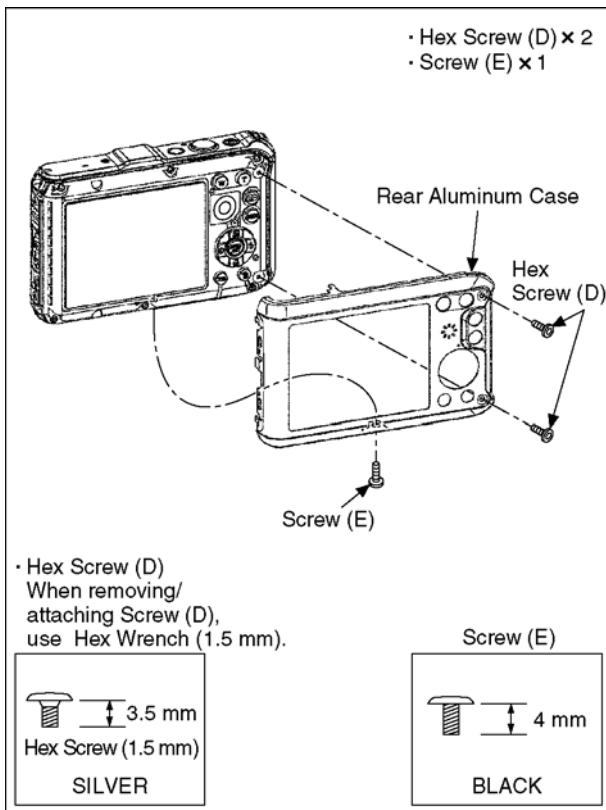

Fig. D3

9.3.4. Removal of Rear Case Unit

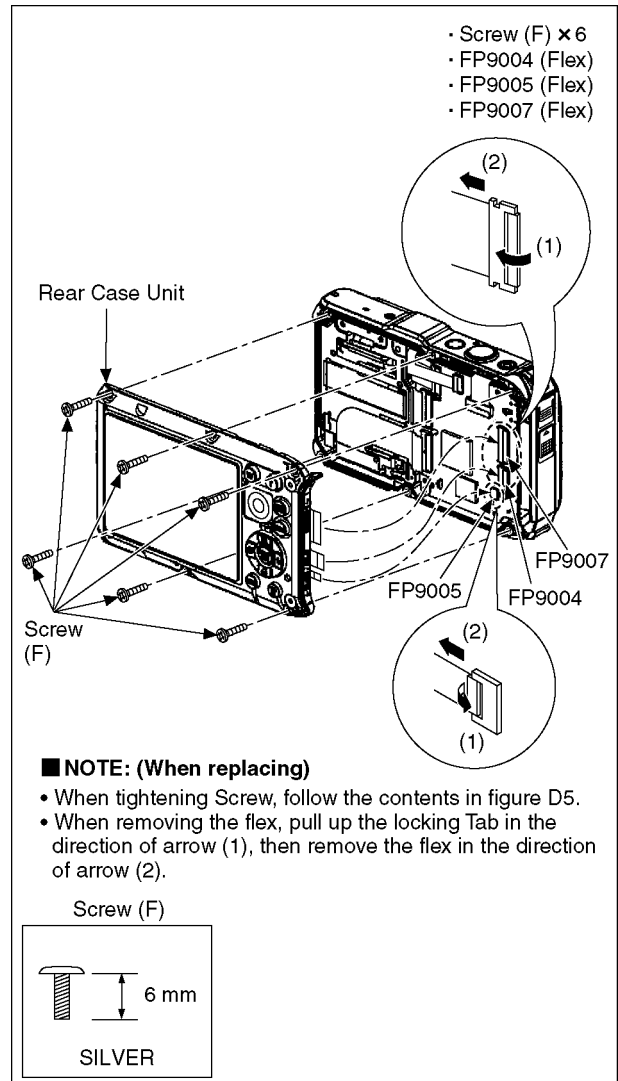
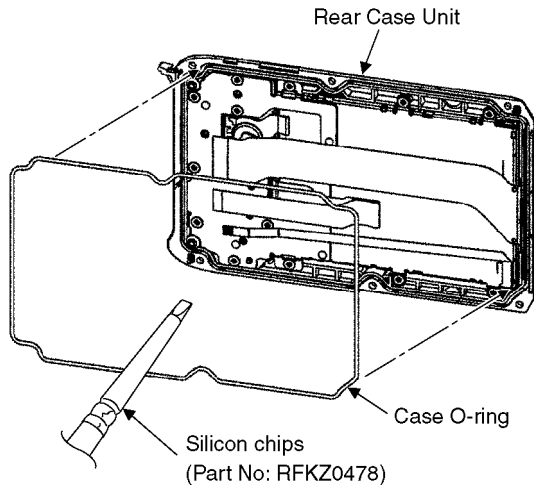

Fig. D4

SCREW TIGHTENING NOTE: TAPE/ORDER/TORQUE

NOTE: (When attaching the rear case unit)

- Do not insert the Flex from any slanted angle.
- Make sure the connector is firmly locked.
- When attaching case O-ring, use Silicon chips (Part No. : RFKZ0478).
- Make sure the O-ring of rear case dose not come off.
- Make sure foreign objects are not attached to the O-ring the waterproof lib of the front case.
- When tighten the screws, use Torque screwdriver (Part No. RFKZ0542) and tighten by the specified torque.
- Tighten the screws in the order of (1) to (6) as shown below.
- To keep waterproof property, not to be stripped thread or stuffed thread.



< Order of tightening screws/ tightening torque >

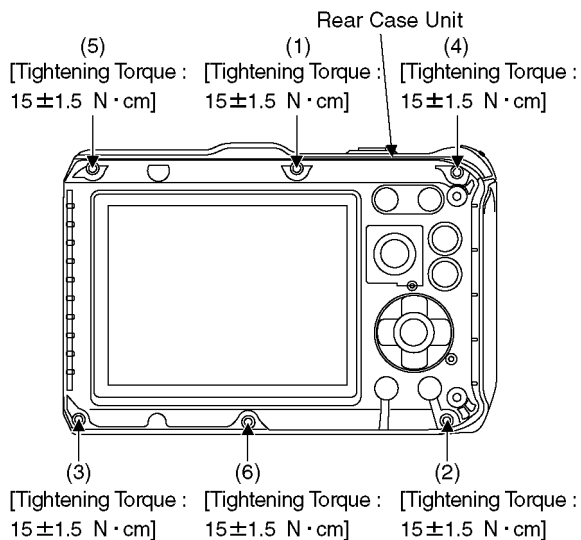

Fig. D5

9.3.5. Removal of Camera Lens Unit

Note: (When Disassembling/Assembling)

1. When dust stuck, use air-Blower to blow off the dust.
2. Do not touch the surface of lens by your hand.
3. Use Lens Cleaning KIT; VFK1900BK (Only supplied as 10 set/Box) is available as Service Aid.

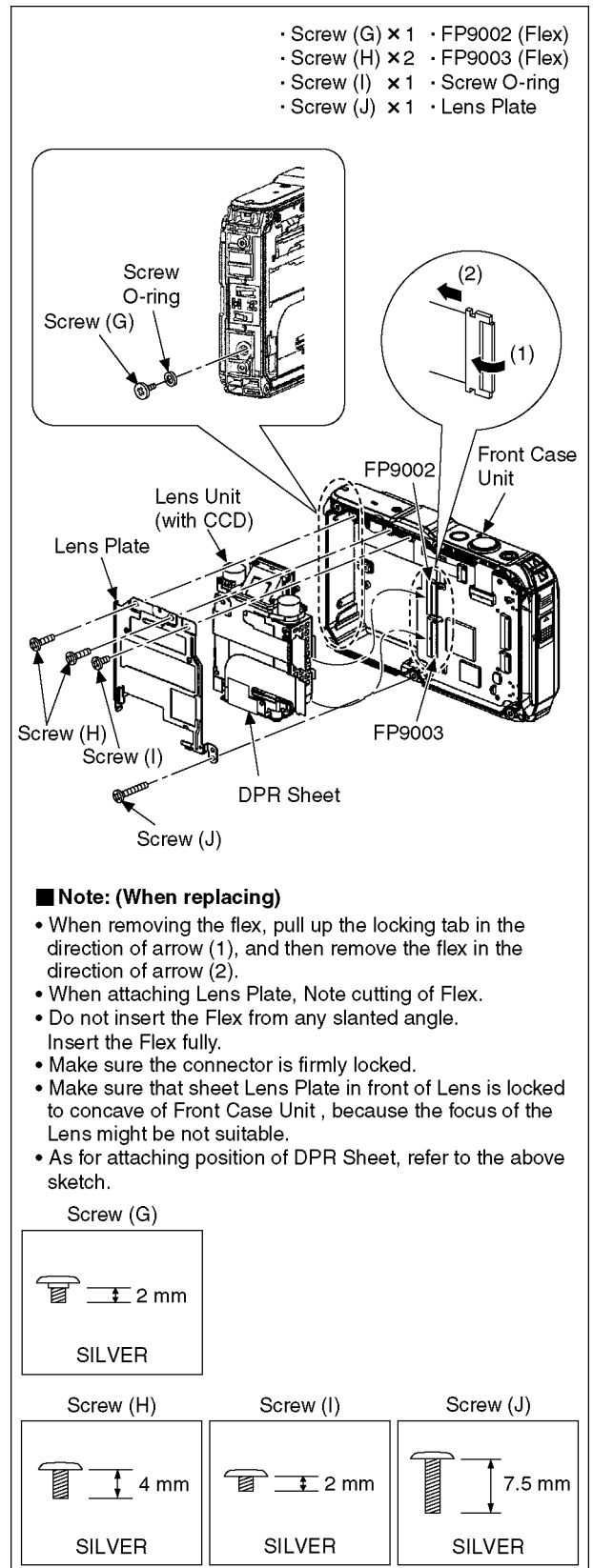

Fig. D6

9.3.6. Removal of Main P.C.B.

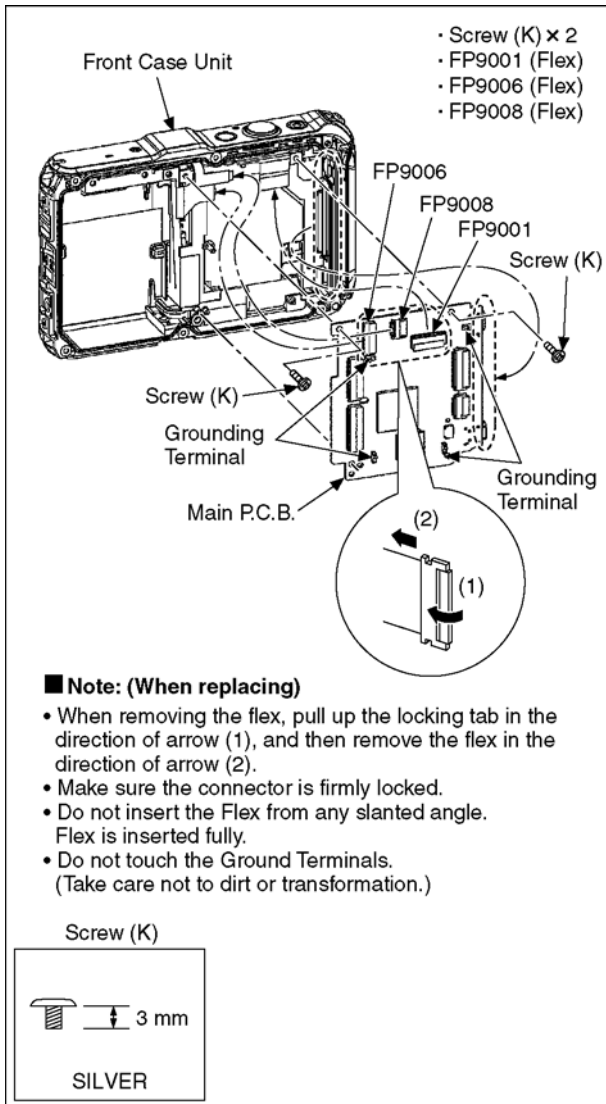

Fig. D7

9.3.7. Removal of Top Ornament

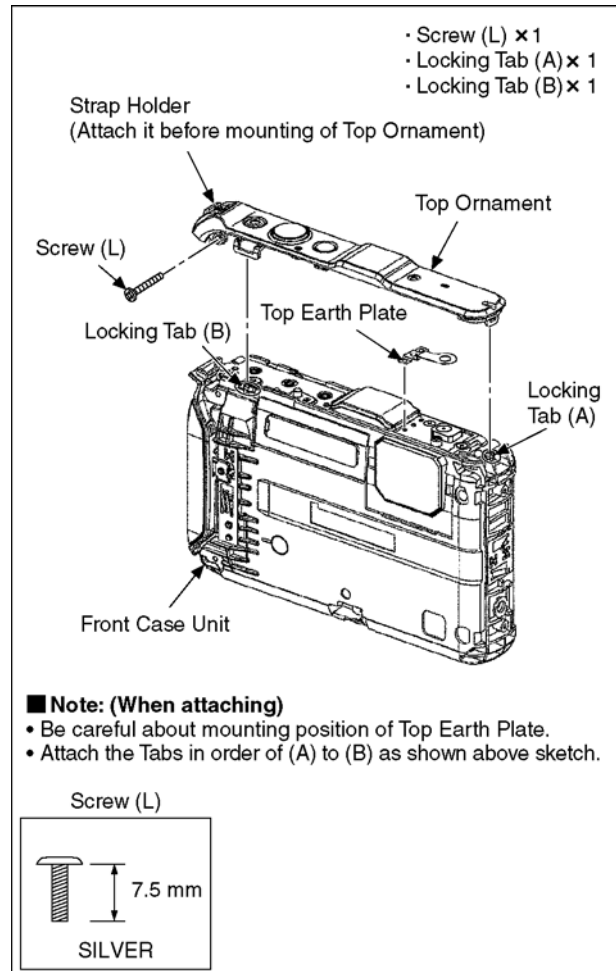

Fig. D8

9.3.8. Removal of Top Button Plate/Top Button Packing

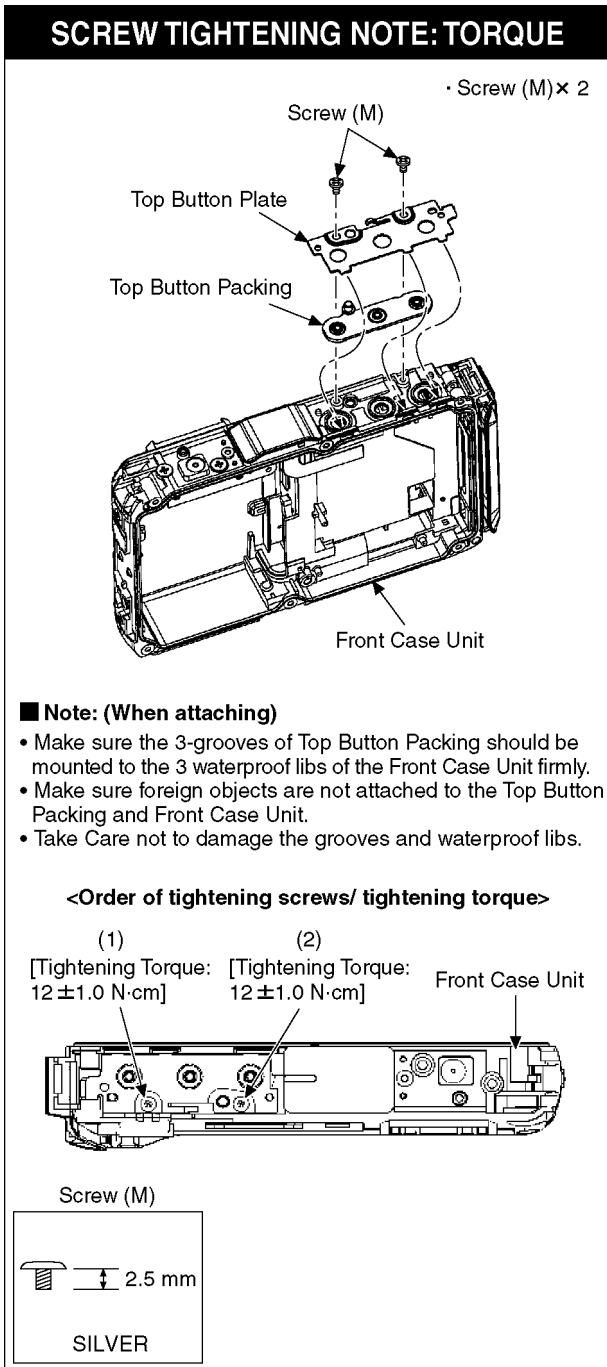

Fig. D9

9.3.9. Removal of Front Case Unit

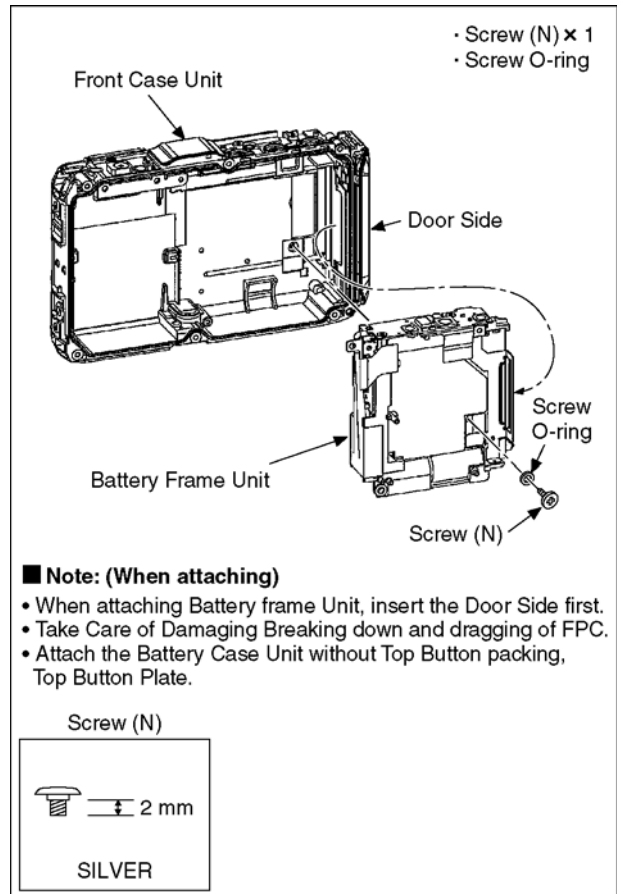

Fig. D10

9.3.10. Removal of Top FPC Unit

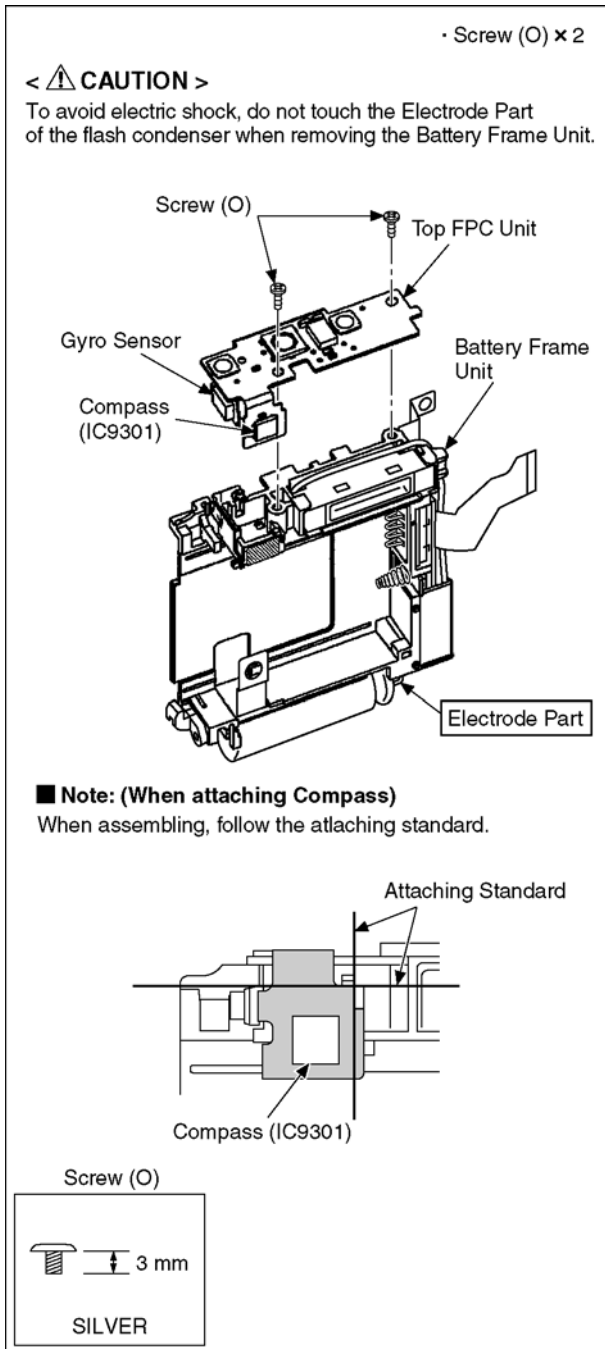

Fig. D11

9.3.11. Removal of Flash P.C.B.

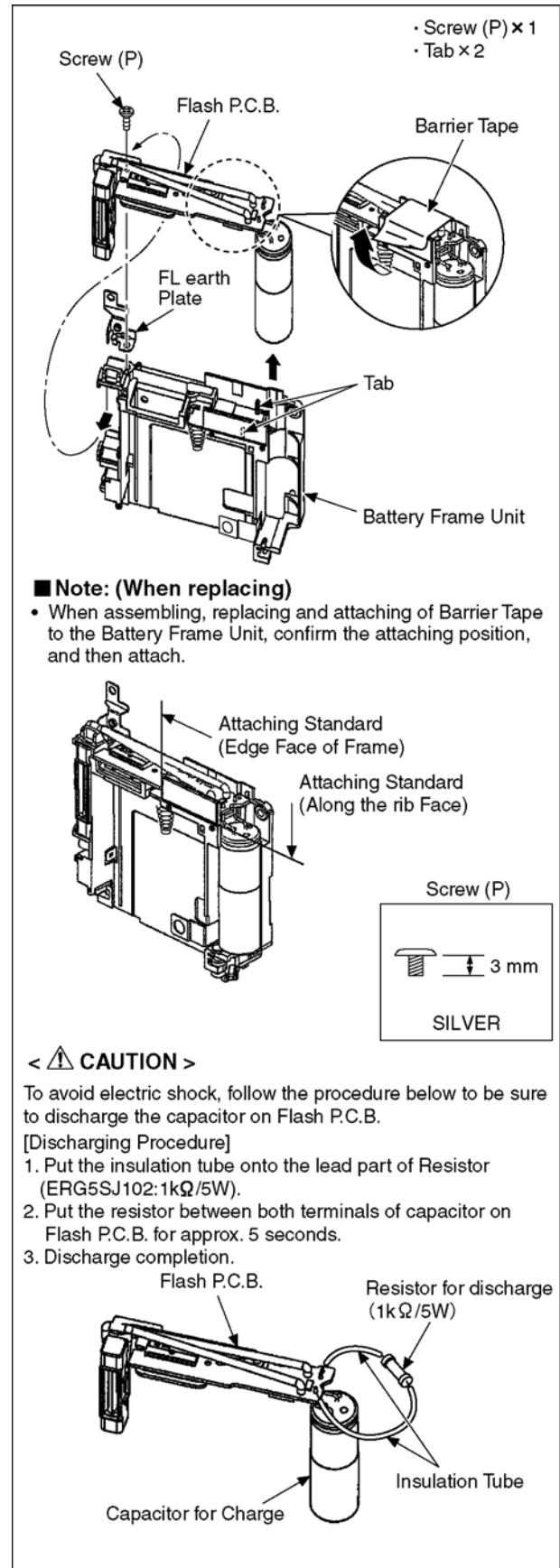

Fig. D12

9.3.12. Removal of MIC GPS P.C.B.

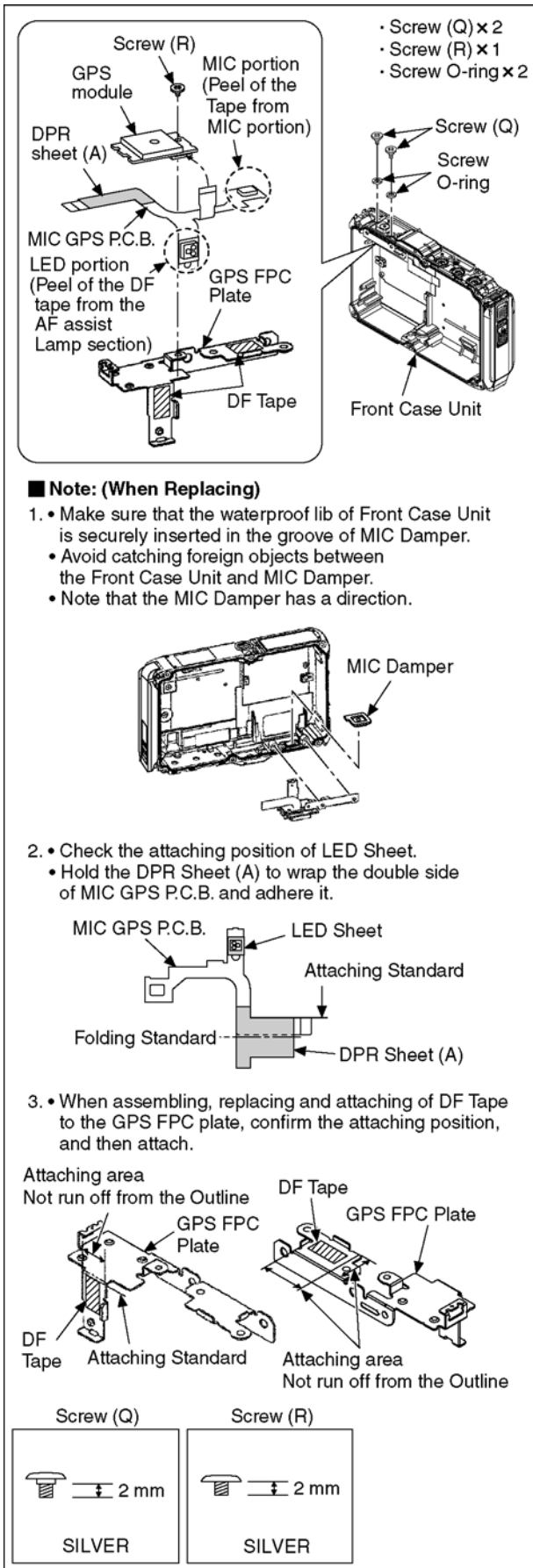

Fig. D13

9.3.13. Removal of Rear Operation P.C.B.

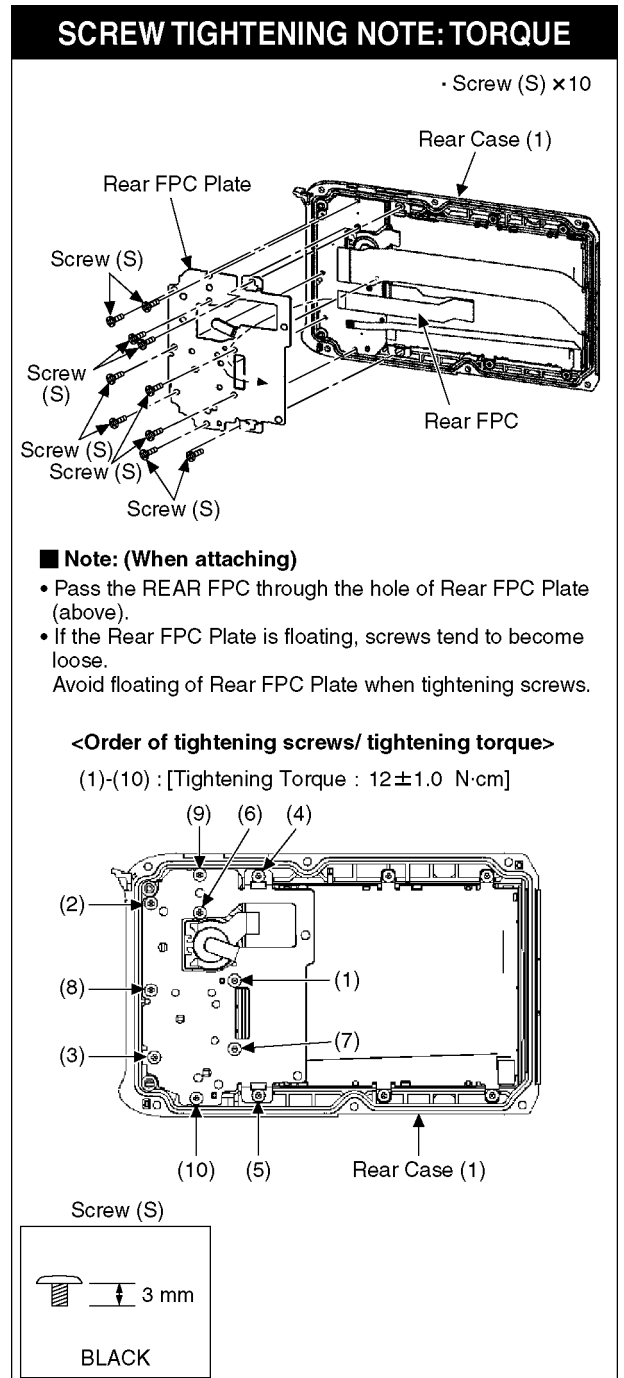

Fig. D14

9.3.14. Removal of LCD Unit

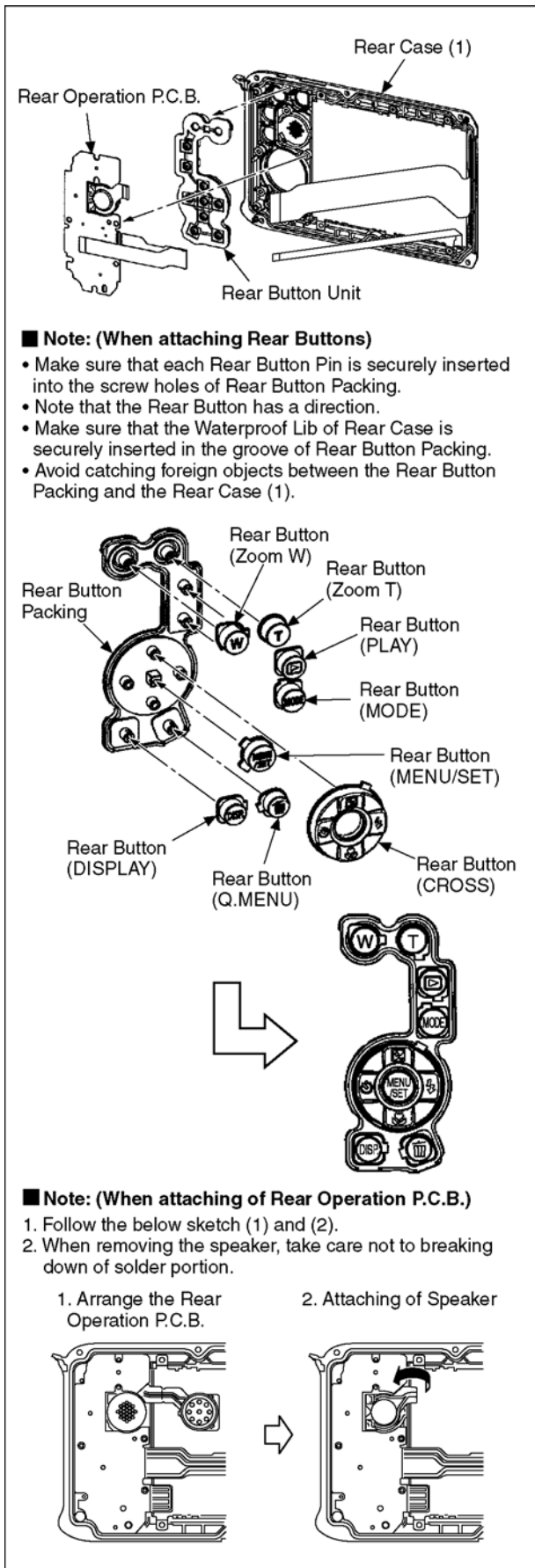

Fig. D15

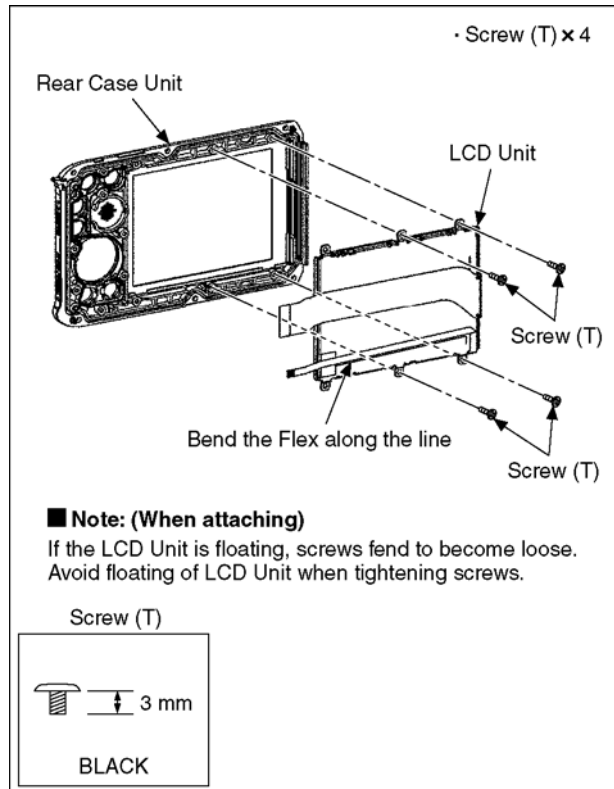

Fig. D16

10 Measurements and Adjustments

10.1. Introduction

When servicing this unit, make sure to perform the adjustments necessary based on the part(s) replaced. Before disassembling the unit, it is recommended to back up the camera data stored in flash-rom as a data file.

IMPORTANT NOTICE (After replacing the MAIN P.C.B.)

After replacing the MAIN P.C.B., it is necessary to use the "DIAS" software to allow the release of adjustment flag(s). The Adjustment software "DIAS" is available at "TSN Website". To download, click on "Support Information from NWBG/VDBG-AVC".

*DIAS (DSC Integrated Assist Software)

10.2. Before Disassembling the unit

10.2.1. Initial Setting Release

The cameras specification are initially set in accordance with model suffix (such as EB, EG, GC, and so on.). Unless the initial setting is not released, an automatic alignment software in the camera is not able to be executed when the alignment is carried out.

Note:

The initial setting should be again done after completing the alignment. Otherwise, the camera may not work properly. Therefore as a warning, the camera display a warning symbol " ! " on the LCD monitor every time the camera is turned off. Refer to the procedure described in "3.8.2. INITIAL SETTINGS" for details.

[How to Release the camera initial setting]

Preparation:

Attach the Battery or AC Adaptor with a DC coupler to the unit.
Set the recording mode dial to Normal picture mode.

Step 1. Temporary cancellation of "INITIAL SETTINGS":

While pressing the UP of Cursor button and MOTION PICTURE button simultaneously, turn the power switch to the ON position.

Step 2. Cancellation of "INITIAL SETTINGS":

Press the PLAYBACK switch.

While pressing UP of Cursor button and MOTION PICTURE button simultaneously. (The camera will beep after this.)
Turn the Power off. (The warning symbol " ! " is displayed on the LCD monitor.)

10.2.2. Flash-Rom Data Backup

When trouble occurs, it is recommended to backup the Flash-rom data before disassembling the unit. There are two kinds of Flash-rom data backup methods:

[ROM_BACKUP (Method of Non-PC backup)]

1. Insert the SD-card into the camera.
2. Set the camera to "Temporary cancellation of the initial settings".
3. Select the "SETUP" menu.
From the "SETUP" menu, select "ROM BACKUP".

Note:

This item is not listed on the customer's "SET UP" menu.

4. When this "ROM_BACKUP" item is selected, the following submenus are displayed.

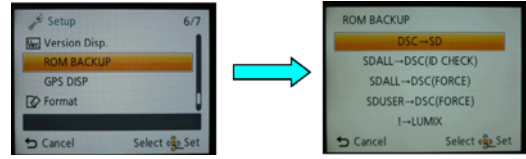

Item	Function	Details
DSC → SD	Save all the DSC's Flash-rom data to SD-CARD	<ul style="list-style-type: none"> • DSC's Flash-rom data is saved to the SD-CARD as a data file by the same format as the TATSUJIN software for the previous models. (DATA BACKUP) -File location: ROOT DIRECTORY in SD-CARD. -File Name: <ol style="list-style-type: none"> 1) User Setup Information data: <Model Number>U.txt [Example: DMC-FX66 : "FX66U.txt"] 2) Optical Adjustment data: <Model Number>F.txt [Example: DMC-FX66 : "FX66F.txt"] • If the concerned file already exists, "OVERWRITE?" message is displayed.
SDALL → DSC (ID CHECK)	Write the all data to DSC's Flash-rom from SD-CARD	<ul style="list-style-type: none"> • The backup data being stored in the SD card is transferred to DSC unit. • ID CHECK: When the model ID is different, data is not transferred. • FORCE: Even if the model ID is different, data is transferred. * If the main PCB is replaced, select "SDALL → DSC(FORCE)".
SDALL → DSC (FORCE)	Write the all data to DSC's Flash-rom from SD-CARD	
SDUSER → DSC (FORCE)	Only "User setup information" is written from the saved file in the SD-CARD to DSC's Flash-rom.	<ul style="list-style-type: none"> • Only the user's "setup" setting condition is transferred to DSC unit. • FORCE: Even if the model ID is different, the data is transferred.
! → LUMIX	Shipping set without initializing "User setup information"	<ul style="list-style-type: none"> • Initial setting is executed without initializing the user's set up setting condition. * The initial setting must be perform while the Self-timer LED is blinking, * The picture data stored in the built-in memory of the DSC is not erased, with this operation.

[DSC Integrated Assist Software (Method of Using PC)]

Same as TATSUJIN software for previous models.

10.2.3. Light Box

If using VFK1164TDVLB Light Box, remove the lens connection ring by loosening three hexagon screws.

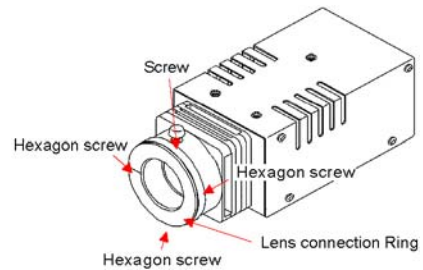

10.3. Details of Electrical Adjustment

10.3.1. How to execute the Electrical Adjustment

It is not necessary to connect the camera to a PC to perform adjustments.

"Flag reset operation" and "Initial setting operation" are required when carrying out the alignment, follow the procedure below.

10.3.1.1. Startup Electrical Adjustment mode

1. Release the initial settings.
2. Insert a recordable SD card.
(Without a SD card, the automatic adjustment can not executed.)
3. Procedure to set the camera into adjustment mode:
 - a. Set the mode dial to Normal picture mode.
 - b. Turn the Power SW off.
 - c. Turn the Power SW on pressing MOTION PICTURE and Menu simultaneously.
LCD monitor displays "SERVICE MODE".
(Refer to Fig.F3-1)

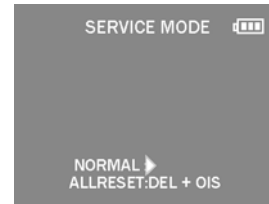

Fig. 3-1

10.3.1.2. Status Adjustment Flag Setting

Reset (Not yet adjusted) the status flag condition.

1. After pressing the DISPLAY button, the LCD monitor displays the Flag status screen (Refer to Fig.3-2.)
2. Select item by pressing the cross keys. (Gray cursor is moved accordingly.)
3. Press the Delete button.

Note:

The selected item's flag has been changed from "F (green)" to "0 (yellow)".

*(Refer to Fig. 3-3)

*Flag conditions:

F (green)

means that the alignment has been completed and the status flag condition is set. In this case, the flag condition should be reset, if you try to carry out the automatic alignment.

0 (yellow)

means that the alignment has been not "completed" and the status flag condition is "reset". In this case, automatic alignment is available.

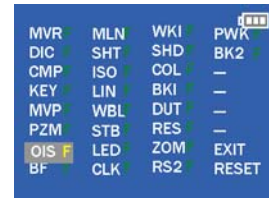

Fig. 3-2

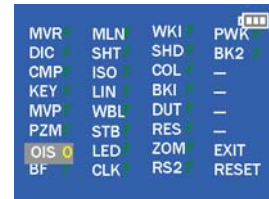

Fig. 3-3

< Example: OIS flag is reset. >

- In case of setting the status flag into set condition again without completion of the alignment, the status flag should be SET by using PC, or UNDO by using ROM BACKUP function.

10.3.1.3. Execute Adjustment

1. Perform step "10.3.1.1." to "10.3.1.2.", to reset the OIS flag status "F" (Set) to "0" (Reset).
2. Press **DISPLAY** button after Flag reset.
OIS Adjustment screen is displayed on the LCD panel.
(Refer to Fig.3-4)
3. Press the shutter button. The adjustment will start automatically.
4. When the adjustment is completed successfully, adjustment report menu appears with Green OK on the LCD monitor. (Refer to Fig.3-5)



Fig. 3-4

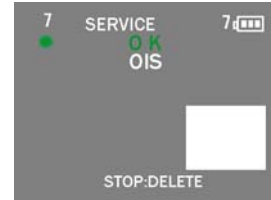

Fig. 3-5

10.3.1.4. Attention point during Adjustment

1. Step "10.3.1.3." procedure shows OIS adjustment as an example. To perform the adjustment, refer to the "10.3.2. Adjustment Specifications" table which shows key point for each adjustment.
2. Do not move the light box, the camera or the chart while adjusting. If one of these is moved accidentally, start the adjustment again.
3. Do not press any buttons/keys until the default menu (Fig.3-6) is displayed on the LCD monitor. Otherwise, adjustment data may not be stored properly.
4. If the adjustment is interrupted accidentally, the alignment data may not be properly saved in the Flash-rom.



Fig. 3-6

10.3.1.5. Finalizing the Adjustment

1. Several adjustment flags can be reset ("F" into "0") at the same time. In this case, when the adjustment has been completed, the screen will change showing the adjustment for the next item until all reset items are completed.
Also, when the shutter button is pressed, the screen jump to the next adjustment item.
2. To cancel the adjustment mode while in the process of performing the adjustment, follow this procedures.
 - (1) Press **DELETE** button.
 - (2) Press "Right of cross key" button.

Note:

- *.If adjustment is cancelled with above procedure, adjustment is not completed. Make sure to adjust it later.
- *.Adjustment software "DIAS" is able to control the status of the adjustment flags.

10.3.2. Adjustment Specifications

The following matrix table shows the relation between the replaced part and the Necessary Adjustment.

When a part is replaced, make sure to perform the necessary adjustment(s) in the order indicated.

The table below shows all the information necessary to perform each adjustment.

Adjustment order	Adjustment Item	FLAG	Purpose	Replacing Parts							JIG/TOOLS	SET UP	How to Operate	
				MAIN PCB	VENUS FHD (IC6001)	MCP (IC6002)	Lens Parts (except C-MOS)	C-MOS Unit	T.PANEL DRIVER (IC9301)	TOUCH PANEL				GYRO (IC9701/IC7301)
1	Venus Zoom	PZM	Venus Zoom Inspection	○	○	○	-	-	-	-	-	NONE	NONE	1) Press Shutter Button. 2) After completed, the "OK" menu appears.
2	OIS sensor	OIS	OIS sensor output level adjustment	○	○	○	○	-	-	-	-	NONE	NONE	1) Press Shutter Button (Do not apply any shock and vibration for the camera while adjusting) 2) After completed, the "OK" menu appears.
3	Backfocus / GYRO	BF	To have the focus tracking curve be appropriate shape and GYRO sensor adjustment	○	○	○	○	○ ※1	○	○	○	• COLLIMATOR (VFK1164TCM02 or VFK1164TCM03 or RFKZ0422)	1) Set the camera in front of collimator so that the distance from collimator to camera becomes about 1 cm as shown in Fig.A. 2) Set the camera angle so that the center of the chart comes to the center of the LCD monitor. [IMPORTANT] The adjustment "NG" might be happened with the following conditions: - Do not put the black colored stuff at the back side of collimator near hunching chart. It needs to get some certain brightness. - Make sure the hunching chart has no dust and dirty condition. - Do not connect a USB cable during adjustment.	1) Press Shutter Button (Do not apply any shock and vibration for the camera while adjusting) 2) After completed, the "OK" menu appears.
4	Monitor Linearity	MLN	Monitor Linearity adjustment	○	○	○	○	○	-	-	-	• LIGHT BOX (VFK1164TDVLB or RFKZ0523)	1) Set the camera in front of LIGHT BOX so that the distance from LIGHT BOX to camera becomes about 2 cm as shown in Fig.B. 2) Aim the LIGHTBOX and make the frame detail alignment so that the entire LCD screen becomes fully "white". (No dark area).	1) Press Shutter Button 2) After completed, the "OK" menu appears.
5	Shutter	SHT	Shutter speed adjustment	○	○	○	○	○	-	-	-	• LIGHT BOX (VFK1164TDVLB or RFKZ0523) • TR CHART (RFKZ0443)	1) Insert the TR chart into the slot of LIGHT BOX. 2) Set the camera in front of LIGHT BOX so that the distance from LIGHT BOX to camera becomes about 16 cm as shown in Fig.B. 3) Set the camera angle so that the color chart is displayed on the LCD monitor fully. [IMPORTANT] The adjustment "NG" might be happened with the following conditions: - Since the lens position is automatically set into certain position after executing auto adjustment, confirm the angle after stopping the lens zoom position. - It is no problem even though the chart on to the LCD monitor slightly cut at the corner. - It is no problem even though the focusing slightly becomes out of focusing condition. - Not connect the USB cable at this stage.	1) Press Shutter Button 2) After completed, the "OK" menu appears.
6	ISO	ISO	ISO sensitivity adjustment	○	○	○	○	○	-	-	-		1) Press Shutter Button 2) After completed, the "OK" menu appears.	
7	High brightness coloration	LIN	High brightness coloration adjustment	○	○	○	○	○	-	-	-		1) Press Shutter Button 2) After completed, the "OK" menu appears.	
8	White Balance	WBL	White balance adjustment under various color temperature	○	○	○	○	○	-	-	-		1) Press Shutter Button 2) After completed, the "OK" menu appears.	
9	CCD Missing Pixels (White)	WKI	Compensation of CCD Missing Pixels (White)	○	○	○	-	○ ※1	-	-	-	NONE	NONE	1) Press Shutter Button 2) After completed, the "OK" menu appears.
10	Color reproduction inspection and Microphone check	COL	Color reproduction inspection and Microphone check	○	○	○	○	○	-	-	-	NONE	Right after pressing the shutter button, enter the continuous sounds (voice) to the microphone until lens unit starting the zooming.	1) Press Shutter Button. Right after pressing the shutter button, make a continuous sound (voice) to the microphone until lens unit starting the zooming. 2) After completed, the "OK" menu appears.
		BKI	Do not use "BK1" adjustment flag for this unit. Use "BK2" adjustment flag, instead. (In case of mostDSC models, the adjustment flag for CCD Missing Pixels is "BK1". But, in this model, "BK2" the adjustment flag for CCD Missing Pixels.)											

Adjustment order	Adjustment Item	FLAG	Purpose	Replacing Parts						JIG/TOOLS	SET UP	How to Operate
				MAIN PCB	VENUS FHD (IC6001)	MCP (IC6002)	Lens Parts (except C-MOS)	C-MOS Unit	T. PANEL DRIVER (IC9301)			
11	CCD Missing Pixels (Black)	BK2	Compensation of CCD Missing Pixels (Black)	○	○	○	-	○	⊕1			<p>1) Prepare the LIGHTBOX (RFKZ0523). (The LIGHTBOX "VFK1164TDVLB" can be used if the front hood of VFK1164TDVLB is removed.)</p> <p>2) Set the ND Filter (VFK1164ND15) to the LIGHTBOX.</p> <p>3) Set the LIGHTBOX and Camera unit so that distance becomes about 2 cm. (Fig. B)</p> <p>NOTE: Do not use "BK1" adjustment flag for this unit. Use "BK2" adjustment flag, instead.</p> <p>1) Set the LIGHTBOX and Camera unit so that the distance becomes about 2 cm. (Refer to Fig. B)</p> <p>2) Press the Shutter Button. (The green ● mark is displayed on LCD.)</p> <p>3) Aim the LIGHTBOX and make the frame detail alignment so that the entire LCD screen becomes fully "white". (No dark area.)</p> <p>4) Press Shutter Button. (The adjustment is executed, and then green ● mark is displayed on LCD.)</p> <p>5) Press Shutter Button. (The green ● mark is displayed on LCD.)</p> <p>7) Press Shutter Button. (The adjustment is executed, and then green ● mark is displayed on LCD.)</p> <p>8) Set the LIGHTBOX and Camera unit so that the distance becomes about 5.2 cm. (Refer to Fig. B)</p> <p>9) Press Shutter Button. (The green ● mark is displayed on LCD.)</p> <p>10) Press Shutter Button. (The adjustment is executed, then "OK" mark is displayed on LCD when the adjustment has been completed successfully.)</p>

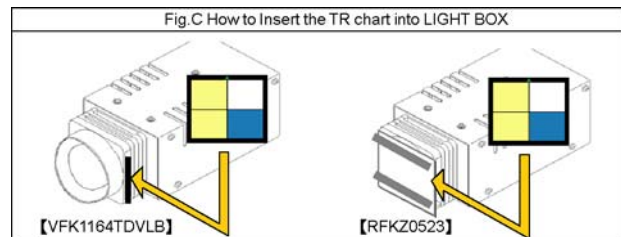
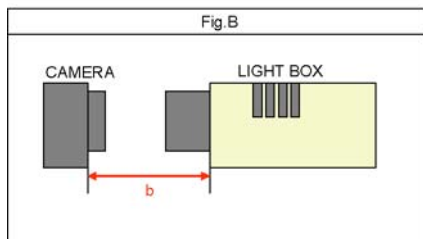
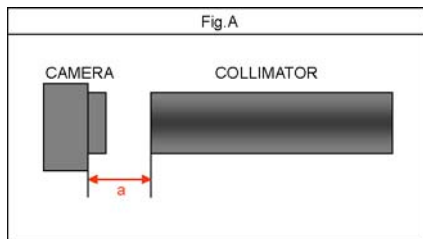

n IMPORTANT NOTICE (After replacing the MAIN P.C.B.)

After replacing the MAIN P.C.B., make sure to perform the "INITIAL SETTINGS" first, then release the "INITIAL SETTINGS" in order to proceed the electrical adjustment.

Note:

1. If electrical adjustment or data re-writing is executed before "INITIAL SETTINGS", suffix code list is never displayed, and it cannot be chosen suitable suffix code.
2. Never remove the battery during initial setting in process.

10.4. After Adjustment

10.4.1. Initial Setting

Since the initial setting has been released to execute the built-in adjustment software, it should be set up again before shipping the camera to the customer.

Refer to the procedure described in "3.8.2. INITIAL SETTINGS" for details.

[IMPORTANT]

1. The initial setting should be done again after completing the alignment. Otherwise, the camera will not work properly.
Therefore as a warning, the camera display a warning symbol "!" on the LCD monitor every time the camera is turned off.
2. Confirm that status of all adjustment flag show "F". Even if one of the adjustment flag shows "0", initial setting programmed is never executed.
3. Adjustment software "DIAS" is able to control the status of the adjustment flags.
The Adjustment software "DIAS" is available at "TSN Website", therefore, access to "TSN Website" at "Support Information from NDBG/VDBG-AVC".

11 Maintenance

11.1. Cleaning Lens and LCD Panel

Do not touch the surface of lens and LCD Panel with your hand.

When cleaning the lens, use air-Blower to blow off the dust.

When cleaning the LCD Panel, dampen the lens cleaning paper with lens cleaner, and the gently wipe the their surface.

Note:

The Lens Cleaning KIT; VFK1900BK (Only supplied as 10 set/Box) is available as Service Aid.

Service Manual

Diagrams and Replacement Parts List

Digital Camera

Model No.

DMC-FT3EB	DMC-TS3P
DMC-FT3EE	DMC-TS3PC
DMC-FT3EF	DMC-TS3PU
DMC-FT3EG	DMC-TS3GH
DMC-FT3EP	DMC-TS3GD
DMC-FT3GC	DMC-TS3GT
DMC-FT3GN	
DMC-FT3SG	

Vol. 1
Colour

- (A).....Blue Type (except DMC-FT3EE/EF, DMC-TS3GT)
- (D).....Orange Type (except DMC-FT3EB/SG)
- (S).....Silver Type (except DMC-FT3EB/EF, DMC-TS3GD/GT/PC)
- (R).....Red Type (except DMC-FT3EE, DMC-TS3GD/GH)

Table of contents

S1. About Indication of The Schematic Diagram.....	S-1	S6. Replacement Parts List.....	S-13
S1.1. Important Safety Notice.....	S-1	S7. Exploded View	S-18
S2. Voltage Chart	S-2	S7.1. Frame and Casing Section.....	S-18
S2.1. Top Operation P.C.B.....	S-2	S7.2. Packing Parts and Accessories Section (1)	S-19
S2.2. Flash P.C.B.	S-2	S7.3. Packing Parts and Accessories Section (2)	S-20
S3. Block Diagram.....	S-3		
S3.1. Overall Block Diagram	S-3		
S4. Schematic Diagram.....	S-4		
S4.1. Interconnection Diagram	S-4		
S4.2. Top Operation Schematic Diagram	S-5		
S4.3. Flash Schematic Diagram	S-6		
S4.4. Rear Operation Schematic Diagram	S-7		
S4.5. MIC GPS Schematic Diagram.....	S-8		
S5. Print Circuit Board	S-9		
S5.1. Top Operation P.C.B.....	S-9		
S5.2. Flash P.C.B.	S-10		
S5.3. Rear Operation P.C.B.....	S-11		
S5.4. MIC GPS P.C.B.	S-11		

S1. About Indication of The Schematic Diagram

S1.1. Important Safety Notice

COMPONENTS IDENTIFIED WITH THE MARK \triangle HAVE THE SPECIAL CHARACTERISTICS FOR SAFETY. WHEN REPLACING ANY OF THESE COMPONENTS USE ONLY THE SAME TYPE.

1. Although reference number of the parts is indicated on the P.C.B. drawing and/or schematic diagrams, it is NOT mounted on the P.C.B. when it is displayed with "\$" mark.
2. It is only the "Test Round" and no terminal (Pin) is available on the P.C.B. when the TP (Test Point) indicated as "●" mark.
3. The voltage being indicated on the schematic diagram is measured in "Standard-Playback" mode when there is no specify mode is mentioned.
4. Although the voltage and waveform available on here is measured with standard frame, it may be differ from actual measurement due to modification of circuit and so on.
5. The voltage being indicated here may be include observational-error (deviation) due to internal-resistance and/or reactance of equipment. Therefore, handle the value indicated on here as reference.
6. Use the parts number indicated on the Replacement Parts List .
7. Indication on Schematic diagrams:

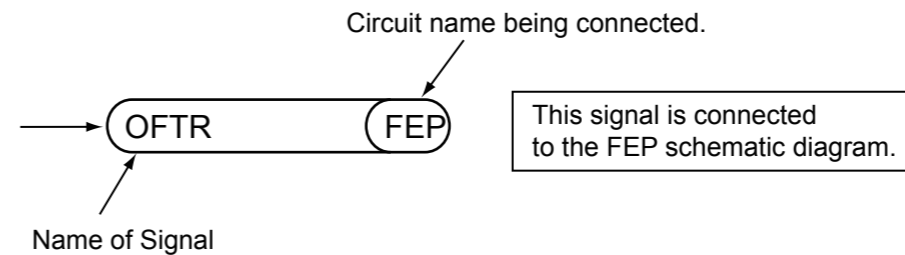

S2. Voltage Chart

Note) Indicated voltage values are the standard values for the unit measured by the DC electronic circuit tester (high-impedance) with the chassis taken as standard.
Therefore, there may exist some errors in the voltage values, depending on the internal impedance of the DC circuit tester.

S2.1. Top Operation P.C.B.

S2.2. Flash P.C.B.

REF No.	PIN No.	POWER ON
IC9301	1	-
IC9301	2	3
IC9301	3	-
IC9301	4	3
IC9301	5	3
IC9301	6	-
IC9301	7	3
IC9301	8	0
IC9301	9	0
IC9301	10	1.2
IC9301	11	0
IC9301	12	0
IC9301	13	0
IC9301	14	-
IC9301	15	0
IC9301	16	3

REF No.	PIN No.	POWER ON
IC8001	1	0
IC8001	2	0
IC8001	3	0
IC8001	4	0
IC8001	5	3.6
IC8001	6	0
IC8001	7	0
IC8001	8	0
IC8001	9	3.1
IC8001	10	4.4

S3. Block Diagram

S3.1. Overall Block Diagram

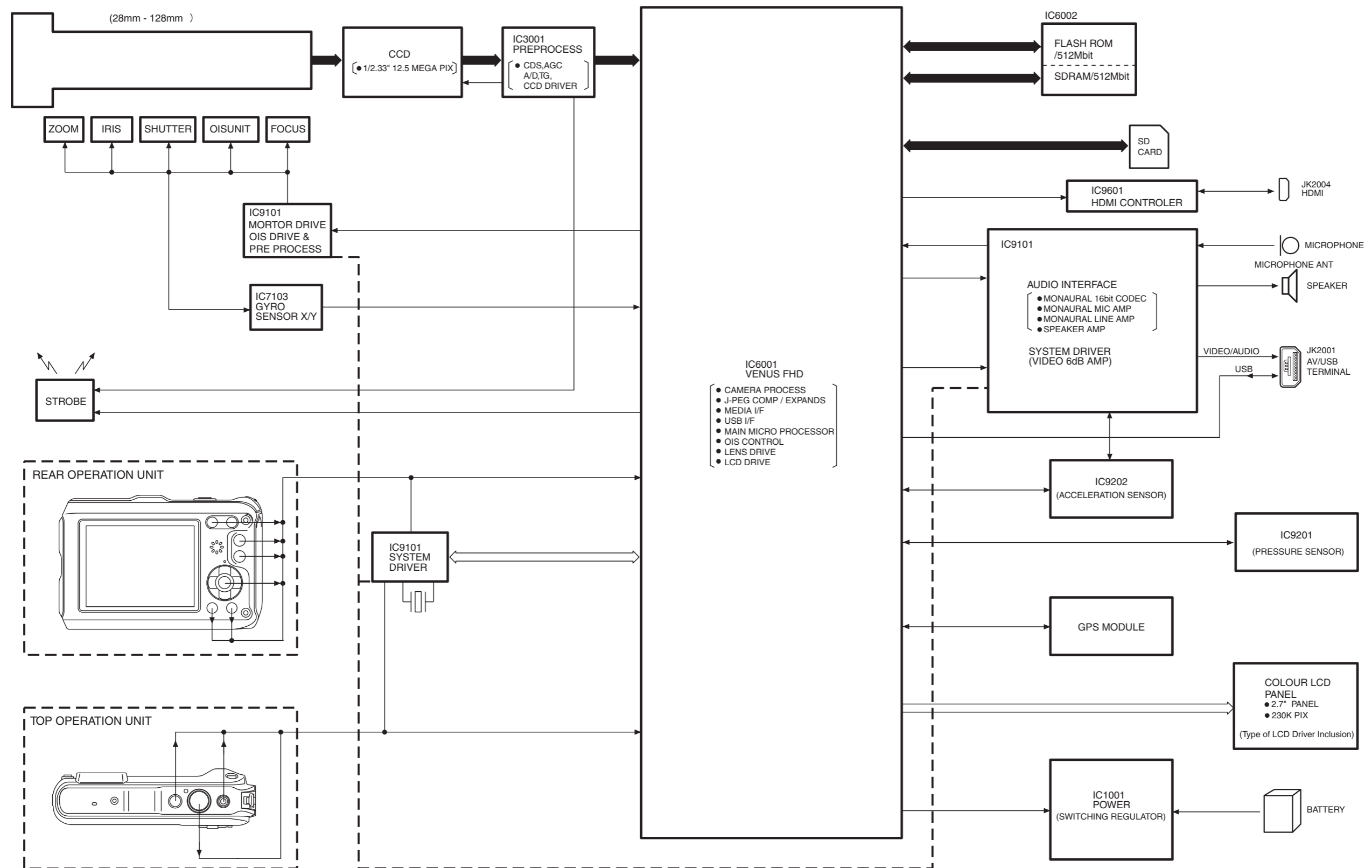

DMC-FT3/TS3 OVERALL BLOCK DIAGRAM

S4. Schematic Diagram

S4.1. Interconnection Diagram

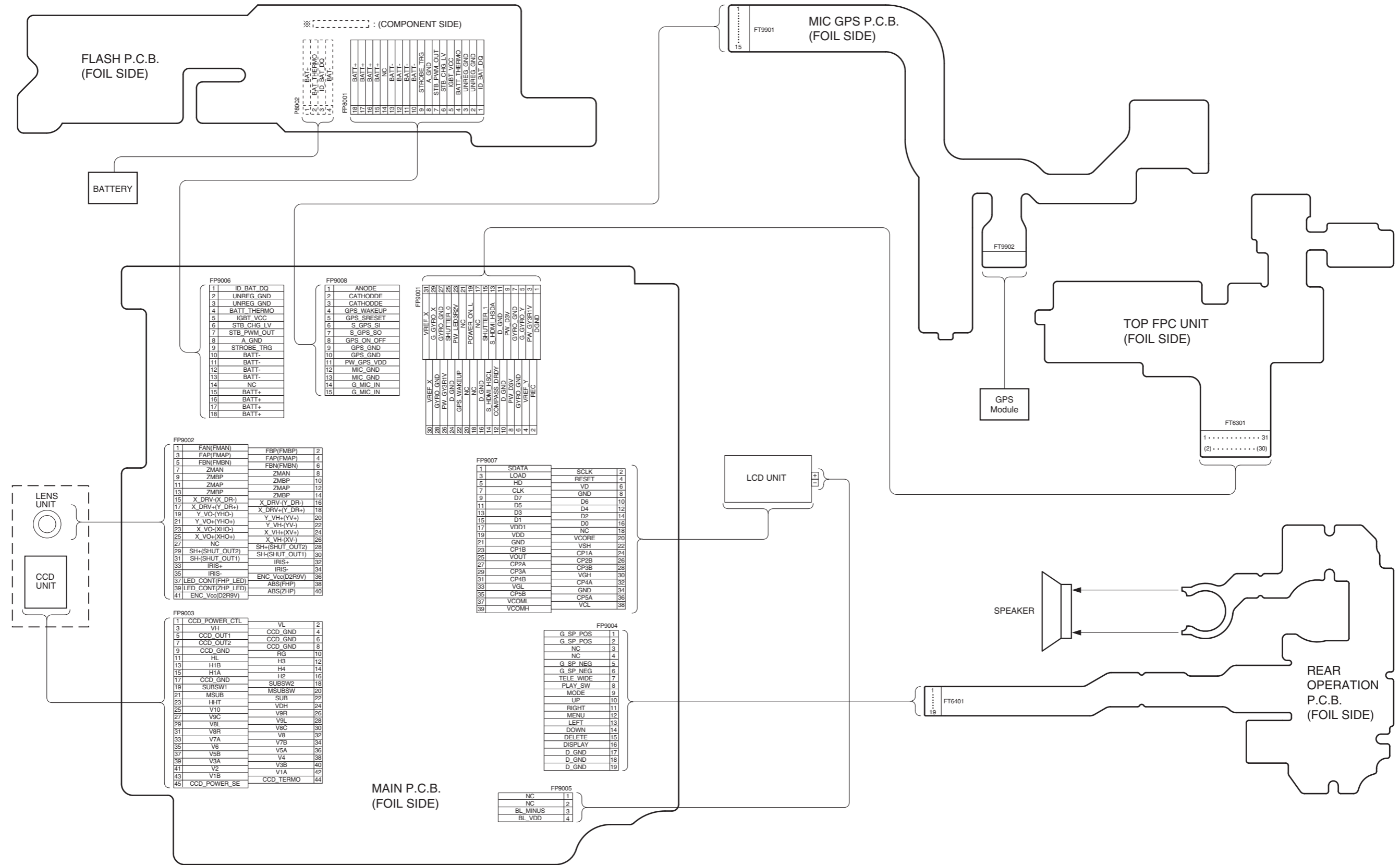

S4.2. Top Operation Schematic Diagram

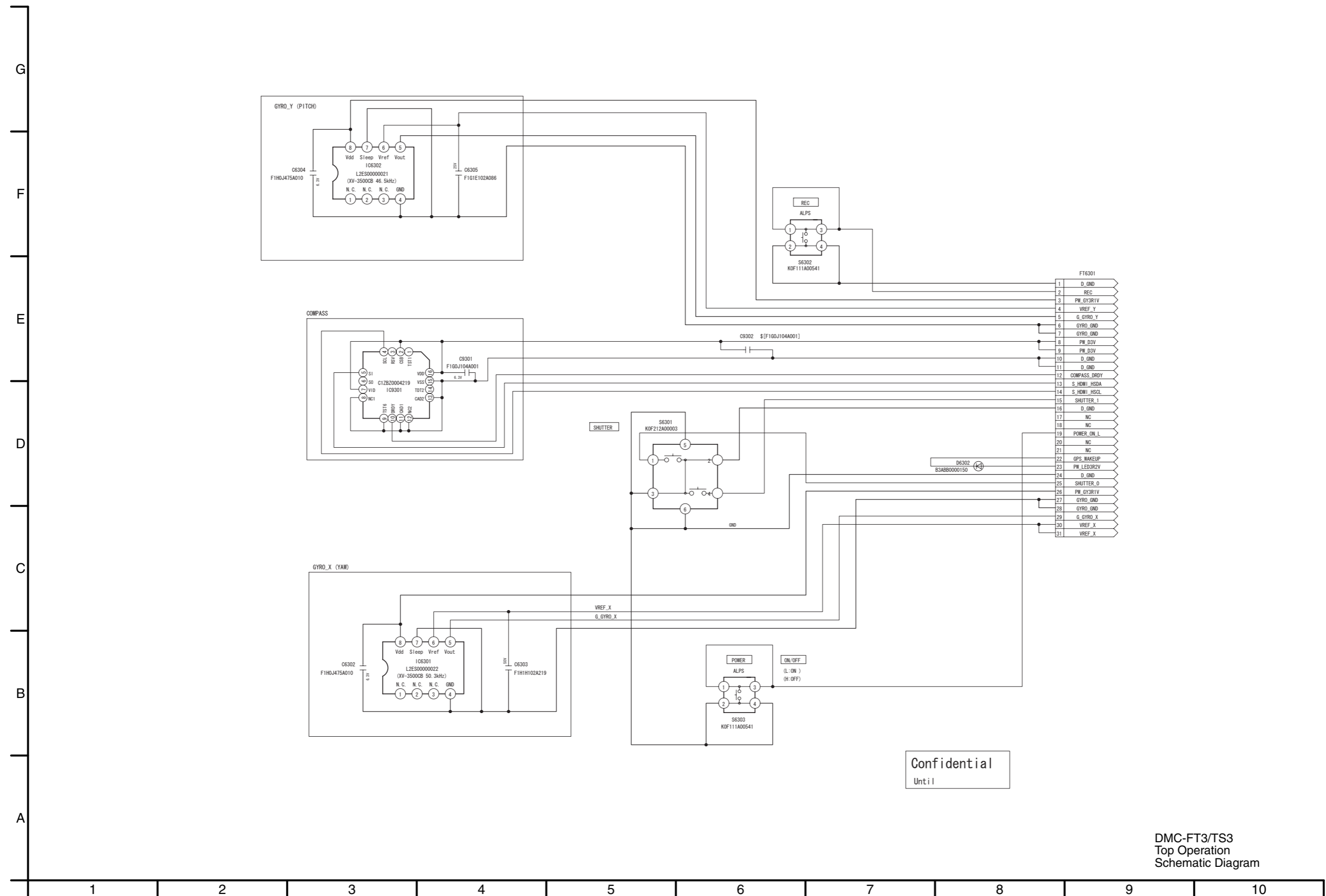

Confidential
Until

S4.3. Flash Schematic Diagram

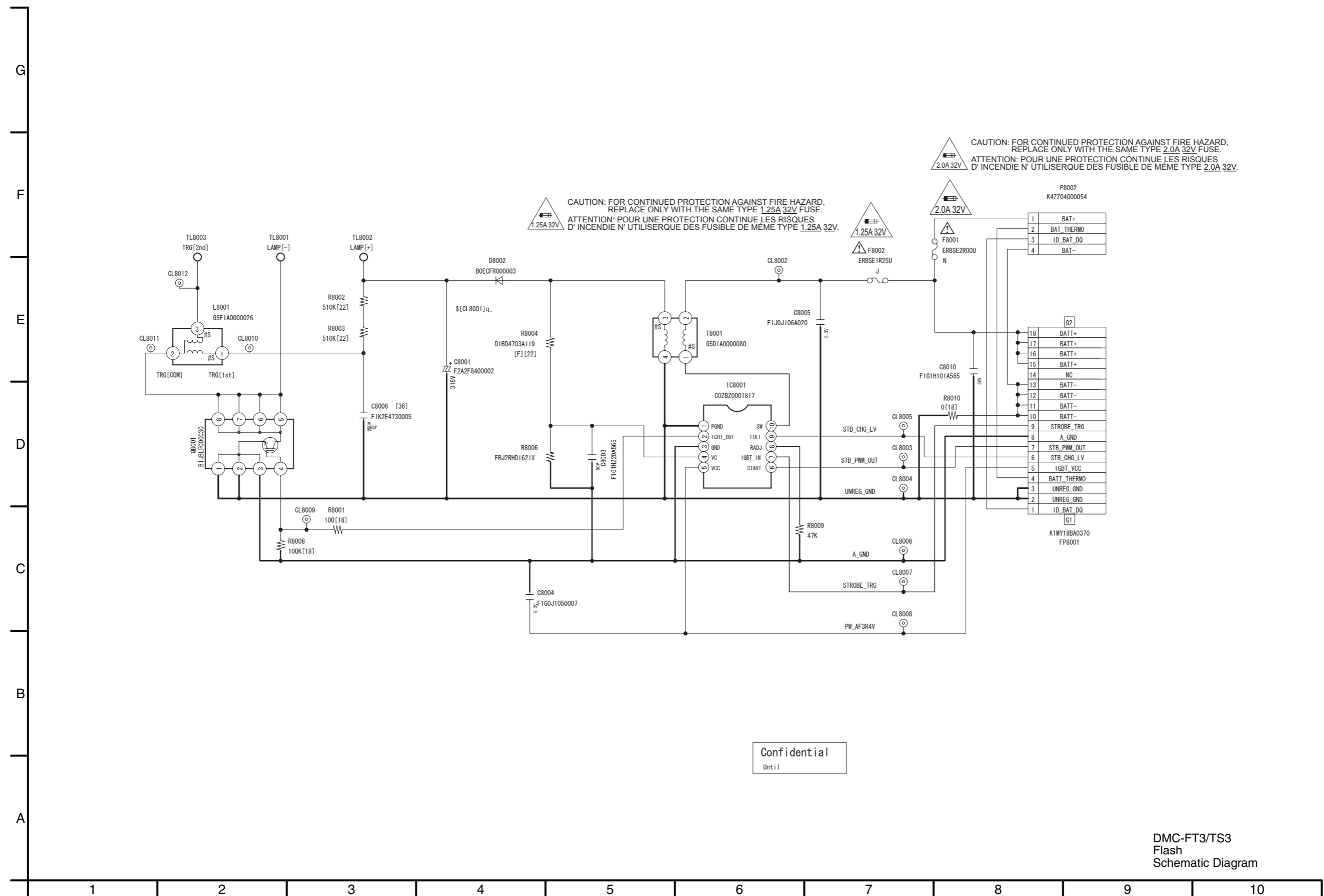

Confidential
Until

S4.4. Rear Operation Schematic Diagram

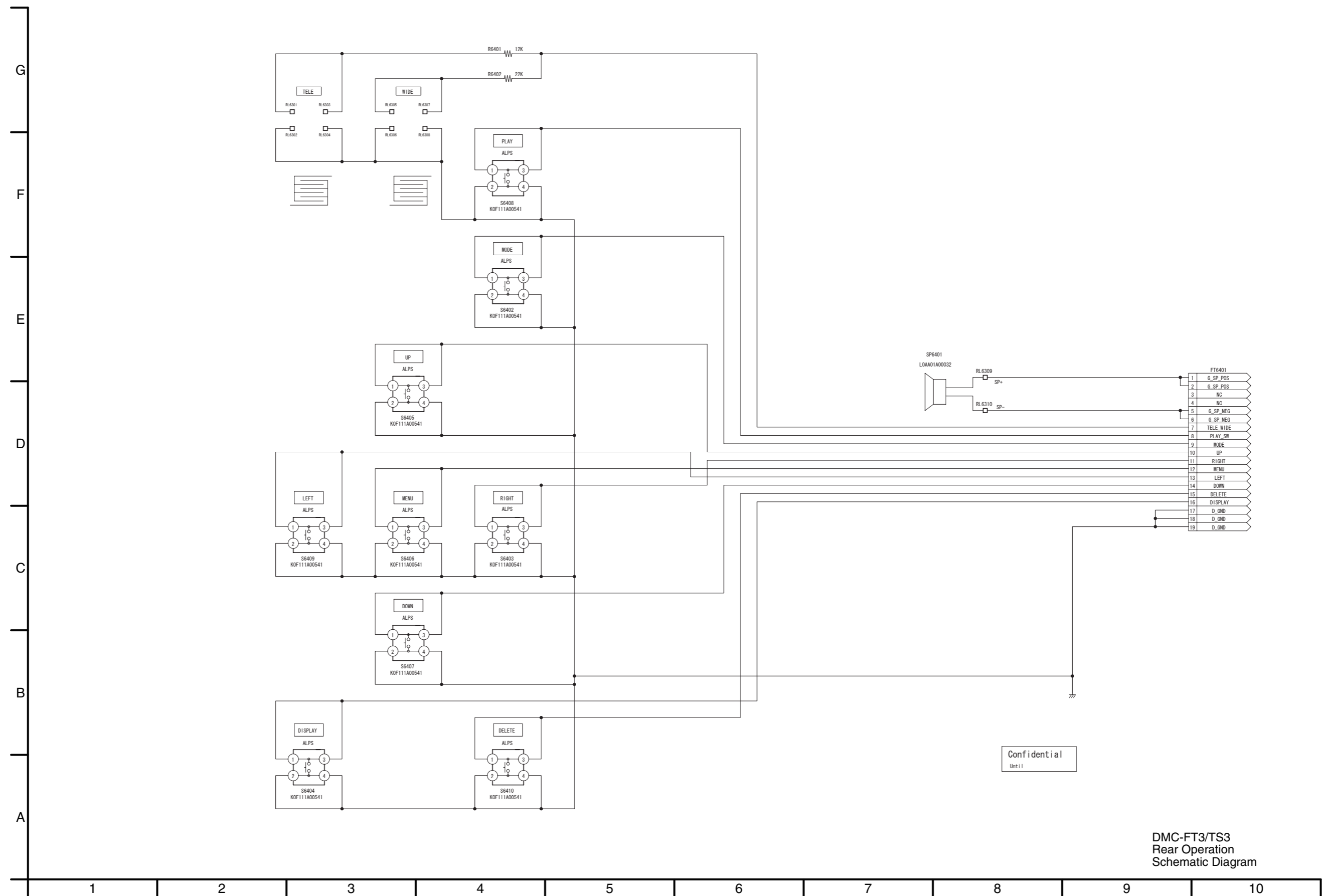

DMC-FT3/TS3
Rear Operation
Schematic Diagram

S4.5. MIC GPS Schematic Diagram

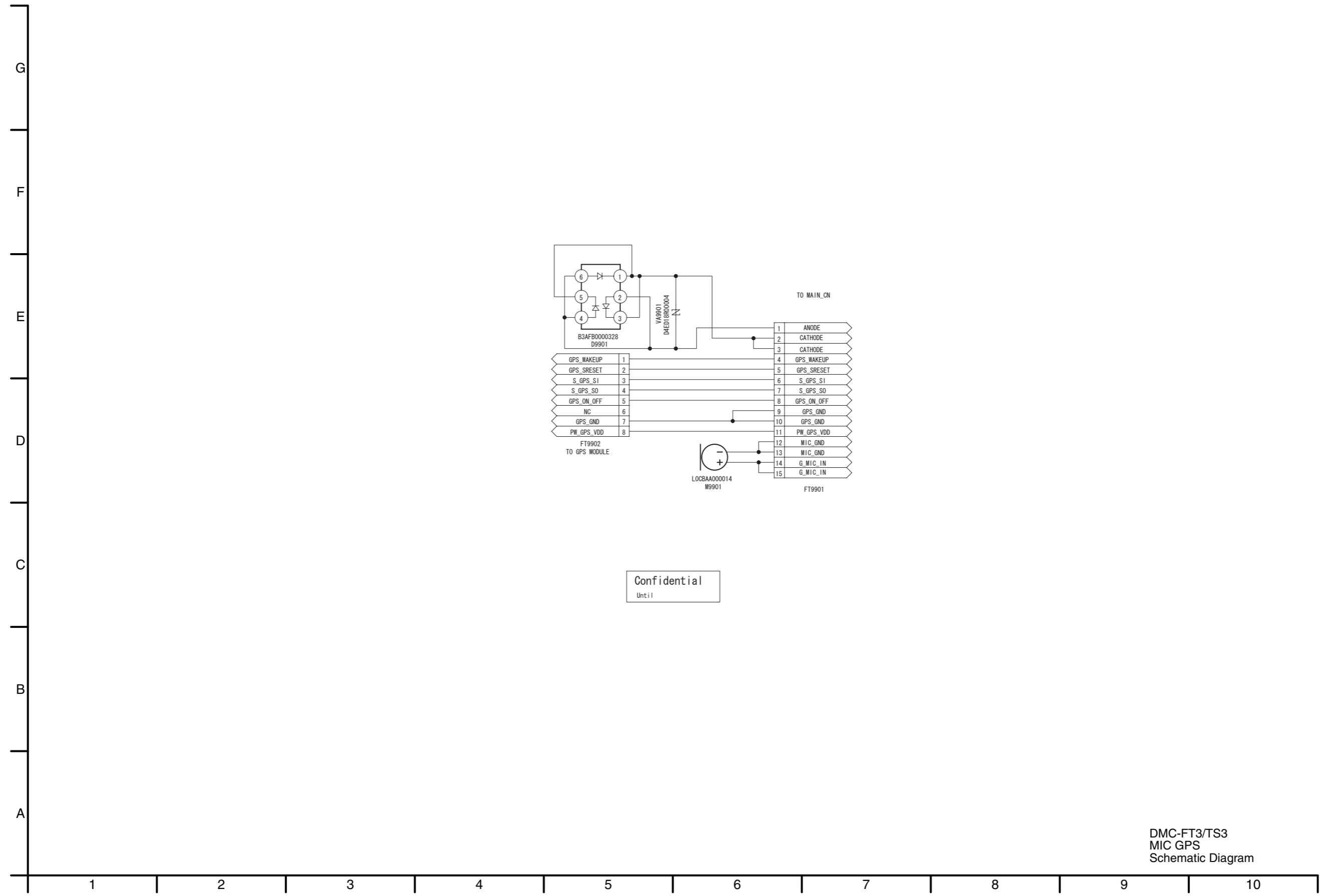

Confidential
Until

S5. Print Circuit Board

S5.1. Top Operation P.C.B.

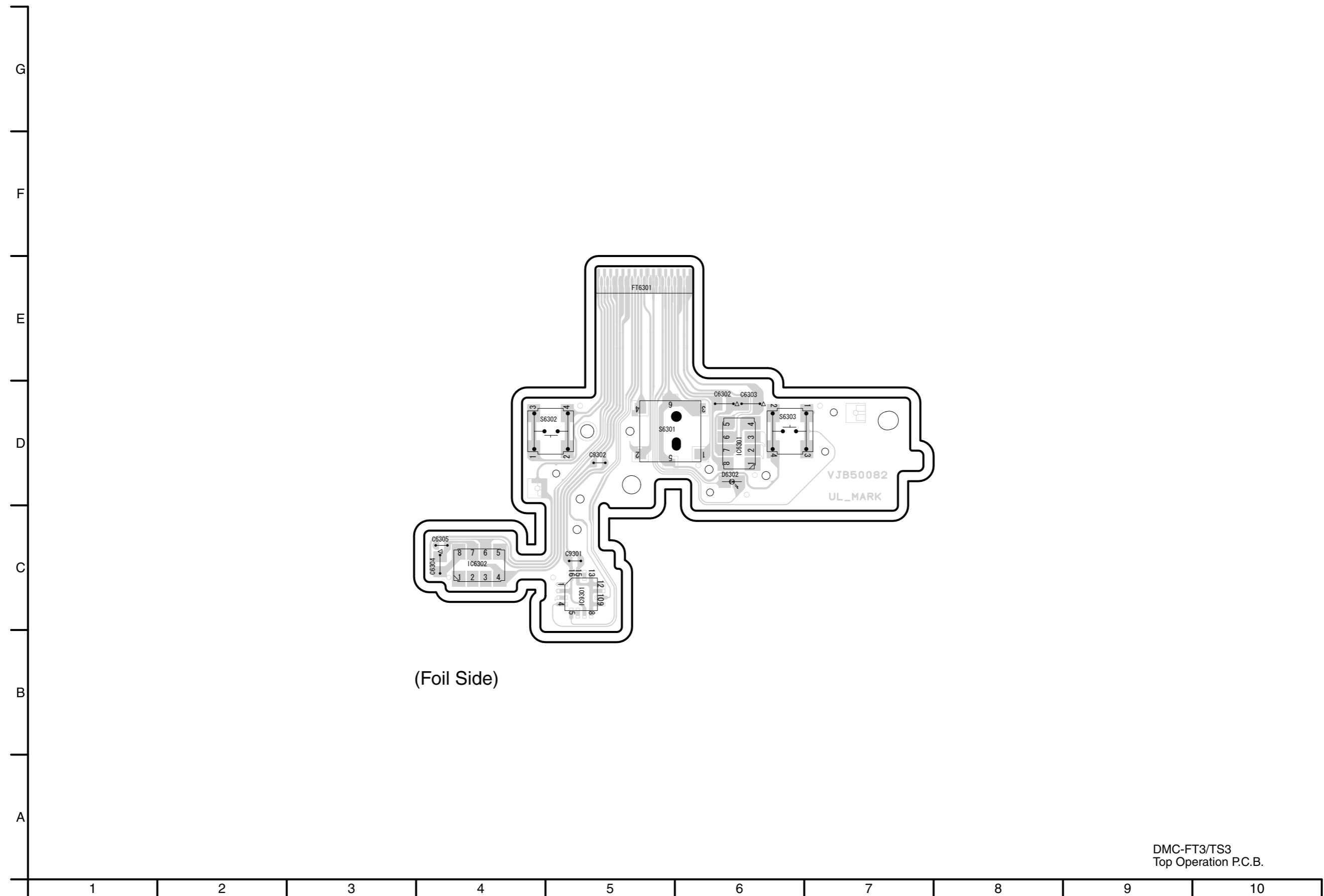

DMC-FT3/TS3
Top Operation P.C.B.

S5.2. Flash P.C.B.

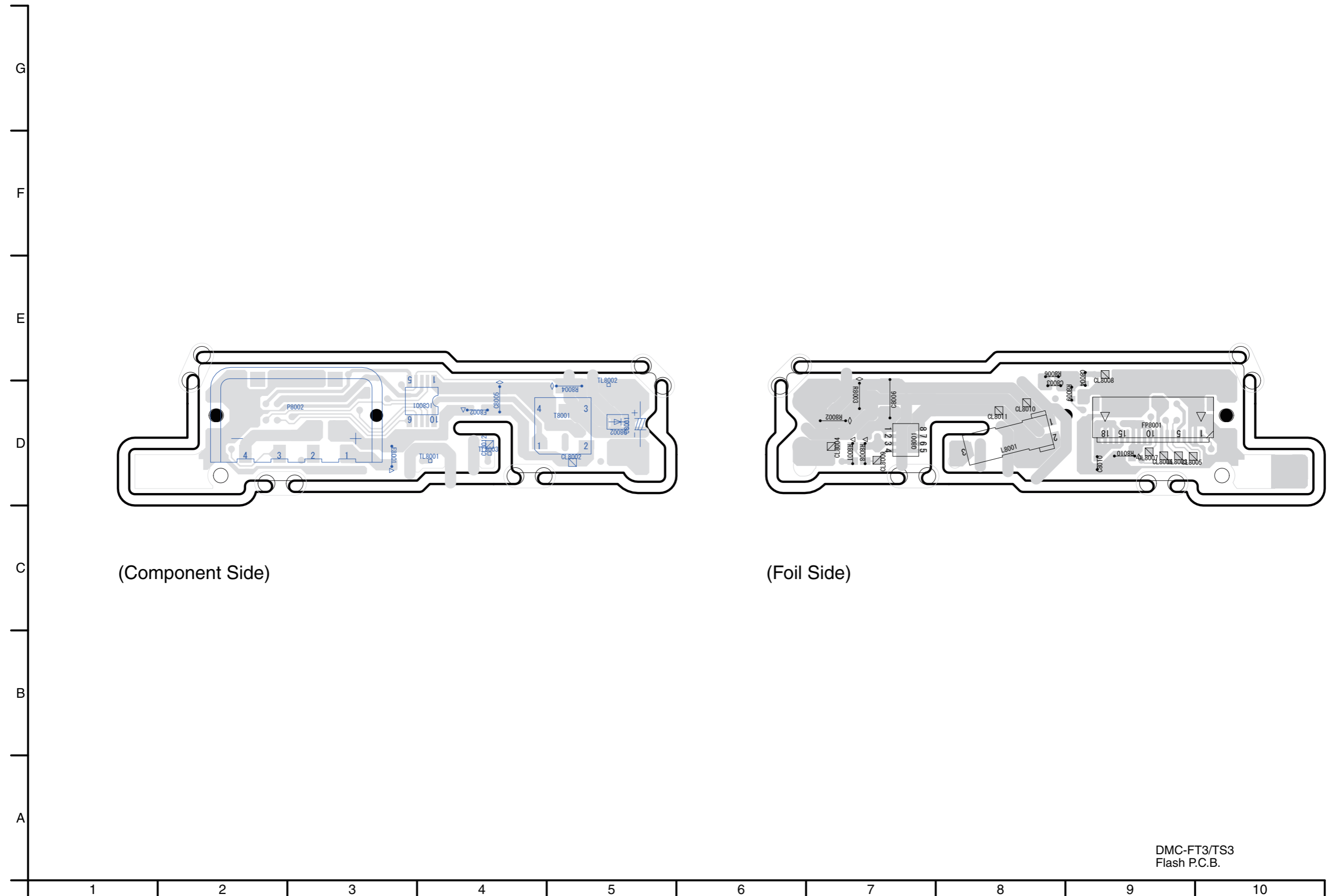

DMC-FT3/TS3
Flash P.C.B.

S5.3. Rear Operation P.C.B. / S5.4. MIC GPS P.C.B.

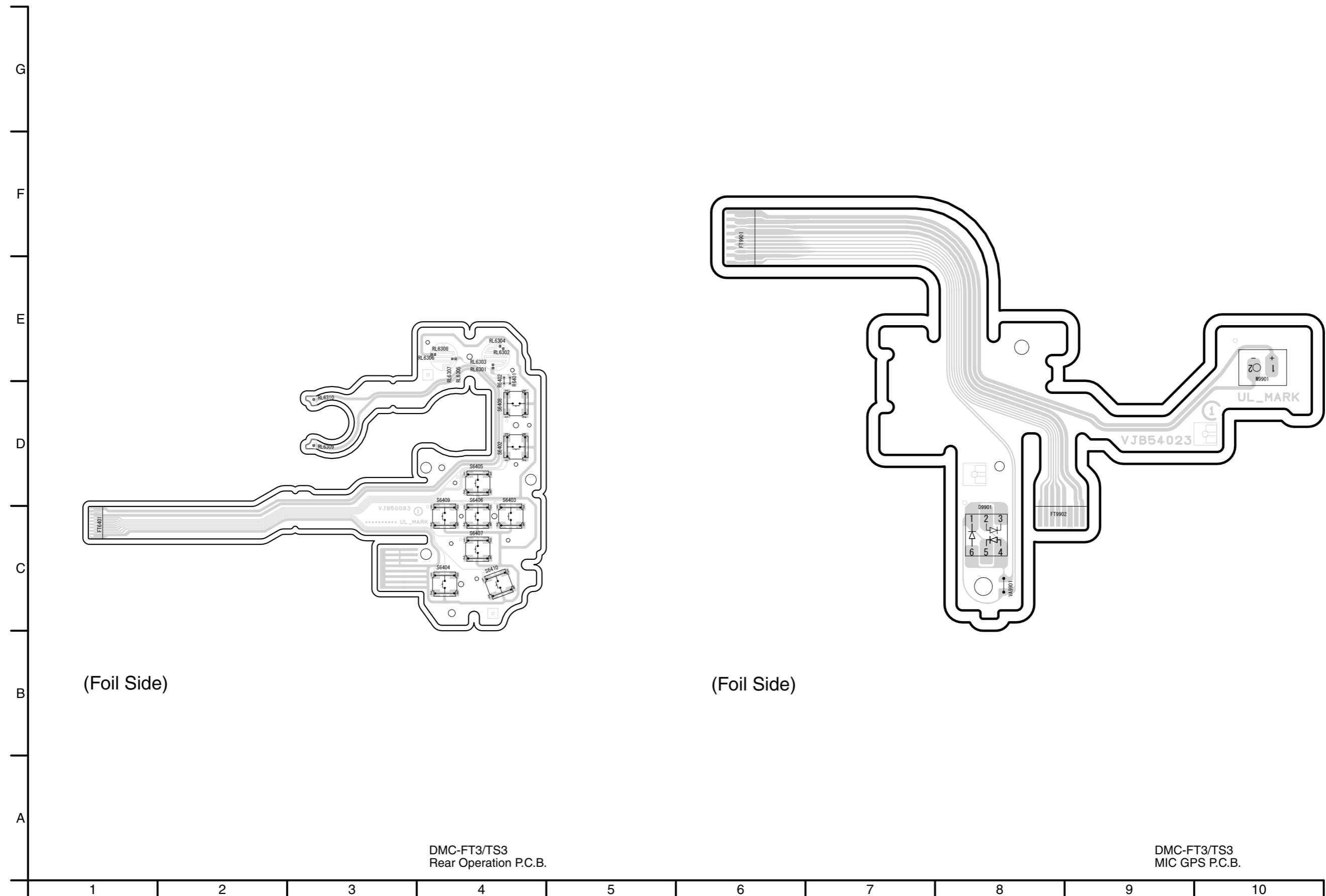

DMC-FT3/TS3
Rear Operation P.C.B.

DMC-FT3/TS3
MIC GPS P.C.B.

S6. Replacement Parts List

- Note:
1. * Be sure to make your orders of replacement parts according to this list.
 2. **IMPORTANT SAFETY NOTICE**
Components identified with the mark \triangle have the special characteristics for safety.
When replacing any of these components, use only the same type.
 3. Unless otherwise specified,
All resistors are in OHMS, K=1,000 OHMS. All capacitors are in MICRO-FARADS (uf), P=uuF.
 4. The marking (RTL) indicates the retention time is limited for this item. After the discontinuation of this assembly in production, it will no longer be available.
 5. Supply of CD-ROM, in accordance with license protection, is allowable as replacement parts only for customers who accidentally damaged or lost their own.

E.S.D. standards for Electrostatically Sensitive Devices, refer to PREVENTION OF ELECTROSTATIC DISCHARGE (ESD) TO ELECTROSTATICALLY SENSITIVE (ES) DEVICES section.

Definition of Parts supplier:

1. Parts marked with [ENERGY] in the remarks column are supplied from Panasonic Corporation Energy Company.
2. Parts marked with [SPC] in the remarks column are supplied from AVC-CSC-SPC. Others are supplied from PAVCSG.

DMC-FT3EB-A

Ref.No.	Part No.	Part Name & Description	Pcs	Remarks
##	VEP50082A	TOP FPC UNIT	1	E.S.D.
##	VEP58155A	FLASH CON P.C.B.	1	(RTL) E.S.D.[PAVCSG]
##	VEP50083A	REAR OPE FPC UNIT	1	(RTL) E.S.D.
##	VEP54023A	MIC G FPC UNIT	1	(RTL) E.S.D.
##	VEP50082A	TOP FPC UNIT		E.S.D.
C6302	F1H0J475A010	C.CAPACITOR CH 6.3V 4.7U	1	
C6303	ECJ1VB1H102K	C.CAPACITOR CH 50V 1000P	1	
C6304	F1H0J475A010	C.CAPACITOR CH 6.3V 4.7U	1	
C6305	F1G1H1020008	C.CAPACITOR CH 50V 1000P	1	
C9301	ECUX0J104KBQ	C.CAPACITOR CH 6.3V 0.1U	1	
D6302	B3ABB0000150	DIODE	1	E.S.D.
IC6301	L2ES00000022	IC	1	E.S.D.
IC6302	L2ES00000021	IC	1	E.S.D.
IC9301	----	IC	1	E.S.D.(NOT SUPPLIED) REPLACE WITH VEP50082A.
S6301	K0F212A00003	SWITCH	1	
S6302	K0F111A00541	SWITCH	1	
S6303	K0F111A00541	SWITCH	1	
##	VEP58155A	FLASH CON P.C.B.		(RTL) E.S.D.[PAVCSG]
C8003	F1G1H220A565	C.CAPACITOR CH 50V 22P	1	[PAVCSG]
C8004	F1G0J1050007	C.CAPACITOR CH 6.3V 1U	1	[PAVCSG]
C8005	F1J0J106A020	C.CAPACITOR CH 6.3V 10U	1	[PAVCSG]
C8006	F1K2E4730005	C.CAPACITOR 250V 0.047U	1	[PAVCSG]
C8010	F1G1H101A565	50V 100P	1	[PAVCSG]
D8002	B0ECFR000003	DIODE	1	E.S.D.[PAVCSG]
F8001	ERBSE2R00U	FUSE 32V 2.0A	1	[PAVCSG]
F8002	ERBSE1R25U	FUSE 32V 1.25A	1	[PAVCSG]
FP8001	K1MY18BA0370	CONNECTOR 18P	1	[PAVCSG]
IC8001	C0ZB20001817	IC	1	E.S.D.[PAVCSG]
L8001	G5F1A0000026	CHIP INDUCTOR	1	[PAVCSG]
P8002	K4ZZ04000054	CONNECTOR 4P	1	[PAVCSG]
Q8001	B1JBLP000030	TRANSISTOR	1	E.S.D.[PAVCSG]
R8001	ERJ3GEYJ101V	M.RESISTOR CH 1/10W 100	1	[PAVCSG]
R8002	ERJ6GEYJ514V	M.RESISTOR CH 1/8W 510K	1	[PAVCSG]
R8003	ERJ6GEYJ514V	M.RESISTOR CH 1/8W 510K	1	[PAVCSG]
R8004	D1BD4703A119	RESISTOR	1	[PAVCSG]
R8006	ERJ2RHD1621X	M.RESISTOR CH 1/16W 1620	1	[PAVCSG]
R8008	ERJ3GEYJ104V	M.RESISTOR CH 1/10W 100K	1	[PAVCSG]
R8009	ERJ2GEJ473X	M.RESISTOR CH 1/16W 47K	1	[PAVCSG]
R8010	ERJ3GEY0R00V	M.RESISTOR CH 1/10W 0	1	[PAVCSG]
T8001	G5D1A0000080	TRANSFORMER	1	[PAVCSG]
##	VEP50083A	REAR OPE FPC UNIT		(RTL) E.S.D.
R6401	ERJ2GEJ123	M.RESISTOR CH 1/16W 12K	1	
R6402	ERJ2GEJ223	M.RESISTOR CH 1/16W 22K	1	
S6402	K0F111A00541	SWITCH	1	
S6403	K0F111A00541	SWITCH	1	

Ref.No.	Part No.	Part Name & Description	Pcs	Remarks
S6404	K0F111A00541	SWITCH	1	
S6405	K0F111A00541	SWITCH	1	
S6406	K0F111A00541	SWITCH	1	
S6407	K0F111A00541	SWITCH	1	
S6408	K0F111A00541	SWITCH	1	
S6409	K0F111A00541	SWITCH	1	
S6410	K0F111A00541	SWITCH	1	
##	VEP54023A	MIC G FPC UNIT		(RTL) E.S.D.
D9901	B3AFB0000328	DIODE	1	E.S.D.
M9901	L0CBAA000014	MICROPHONE UNIT	1	
VA9901	D4ED18R00004	VARISTOR	1	

DMC-FT3EB-A

Ref.No.	Part No.	Part Name & Description	Pcs	Remarks
1	VKM8987	SIDE ORNAMENT R	1	
2	VEP58155A	FLASH CON P.C.B.	1	(RTL) E.S.D.[PAVCSG]
4	VGQ0W23	TOP FPC SHEET	1	
5	VYK4L63	REAR CASE(1) U	1	
6	VGQ0U27	DPR SHEET	1	
7	VGQ0W11	LENS CUSHION	1	
8	VYK4V88	LCD UNIT	1	
9	VWJ2256	FLASH MAIN FPC	1	
10	VMP9914	LENS PLATE	1	
12	VXW1212	LENS UNIT (W/CCD)	1	
13	VMP9915	REAR FPC PLATE	1	
14	VEK0R44	FLASH U	1	[PAVCSG]
16	VYQ6761	GPS PLATE UNIT	1	
17	VGQ0V82	LED SHEET	1	
18	VGQ0V48	DPR SHEET	1	
19	VGQ0U13	DF TAPE	1	[PAVCSG]
20	VMC2167	FL EARTH PLATE	1	[PAVCSG]
21	VEP54023A	MIC G FPC UNIT	1	(RTL) E.S.D.
22	VYK4L68	FRONT CASE(1) U	1	
23	N5HZZ0000090	GPS UNIT	1	
24	VEP56129B	MAIN P.C.B.	1	(RTL) E.S.D. EB,EF,EG,EP
24	VEP56129A	MAIN P.C.B.	1	(RTL) E.S.D. EE,GC,GN,SG, GD,GH,GT,P,PC,PU
25	VEP50082A	TOP FPC UNIT	1	E.S.D.
26	VGQ0T85	FC PIECE	1	
28	VKH0465	STRAP HOLDER	1	
29	VMB4469	BATT DOOR SPRING	1	
△ 30	F2A2F8400002	FLASH CHRQ CAPA. U	1	(C8001)[PAVCSG]
32	VMC2169	TOP EARTH PLATE	1	
33	VGQ0W29	STB CUSHION	1	[PAVCSG]
35	VYK4L72	TOP ORNAMENT U	1	(FT3) [PAVCSG]
35	VYK4U55	TOP ORNAMENT U	1	(TS3) [PAVCSG]
36	VYK4U78	FRONT ALMI U	1	(-A) EXCEPT TS3P-A
36	VYK4U79	FRONT ALMI U	1	(-R) EXCEPT TS3P-R
36	VYK4U77	FRONT ALMI U	1	(-S) EXCEPT TS3P-S
36	VYK4U80	FRONT ALMI U	1	(-D) EXCEPT TS3P-D
36	VYK4U81	FRONT ALMI U	1	P-S
36	VYK4U82	FRONT ALMI U	1	P-A
36	VYK4U83	FRONT ALMI U	1	P-R
36	VYK4U84	FRONT ALMI U	1	P-D
37	VYK4L71	BATTERY DOOR U	1	[PAVCSG]
38	L0AA01A00032	SPEAKER	1	(SP6401)
39	VEP50083A	REAR OPE FPC UNIT	1	(RTL) E.S.D.
40	VMC2170	BOTTOM EARTH PLATE	1	
42	VYK4L61	REAR ALMI CASE U	1	(-S) [PAVCSG]
42	VYK4U36	REAR ALMI CASE U	1	(-A) [PAVCSG]
42	VYK4U37	REAR ALMI CASE U	1	(-R) [PAVCSG]
42	VYK4U38	REAR ALMI CASE U	1	(-D) [PAVCSG]
43	VMG1981	MIC DAMPER	1	
44	VMP9919	TOP BUTTON PLATE	1	
45	VMS8171	DOOR SHAFT	1	
46	VQL2F13	BATTERY LABEL	1	
△ 64	ML-421S/ZTK	BUTTON BATTERY	1	(B6402)[ENERGY]
69	VGQ0S49	BATTERY FRAME	1	[PAVCSG]
70	VGQ9405	WATER LABEL	1	[PAVCSG]
71	VGU0H92	BATT LOCK KNOB	1	[PAVCSG]
72	VMB4340	BATT OUT SPRING	1	[PAVCSG]
73	VGQ0V49	DPR SHEET	1	
74	VMB4465	BATT LOCK SPRING	1	[PAVCSG]
75	VMB4466	EARTH SPRING	1	[PAVCSG]
76	VMP9916	BATT LOCK PLATE	1	[PAVCSG]
77	VMS8149	BATT LOCK SHAFT	1	[PAVCSG]
78	VGQ0S50	BARRIER TAPE	1	[PAVCSG]
79	VGQ0V50	DPR SHEET	1	
80	VGU0H84	REAR BUTTON DISPLAY	1	[PAVCSG]
81	VGU0H85	REAR BUTTON Q.MENU	1	[PAVCSG]
82	VGU0H86	REAR BUTTON MENU SET	1	[PAVCSG]
83	VGU0H87	REAR BUTTON CURSOR	1	[PAVCSG]
84	VGU0H88	REAR BUTTON PLAY	1	[PAVCSG]
85	VGU0H89	REAR BUTTON MODE	1	[PAVCSG]
86	VGU0H90	ZOOM BUTTON T	1	[PAVCSG]
87	VGU0H91	ZOOM BUTTON W	1	[PAVCSG]
88	VGQ0W16	SIDE EARTH TAPE	1	
89	VGQ0W16	SIDE EARTH TAPE	1	

Ref.No.	Part No.	Part Name & Description	Pcs	Remarks
B1	VHD1678	SCREW	1	
B2	VHD1678	SCREW	1	
B3	VHD2336	SCREW	1	
B4	VHD2212	SCREW	1	
B5	VHD2212	SCREW	1	
B6	VHD2074	SCREW	1	
B7	VHD2074	SCREW	1	
B8	VHD2074	SCREW	1	
B9	VHD1759	SCREW	1	
B10	VHD1759	SCREW	1	
B12	VHD2037	SCREW	1	
B13	VHD1678	SCREW	1	
B14	VHD2074	SCREW	1	
B15	VHD2289	SCREW	1	
B16	VHD2289	SCREW	1	
B17	VHD1909	SCREW	1	
B18	VHD1909	SCREW	1	
B19	VHD1909	SCREW	1	
B20	VHD1909	SCREW	1	
B21	VHD1909	SCREW	1	
B22	VHD1909	SCREW	1	
B23	VHD1909	SCREW	1	
B24	VHD1909	SCREW	1	
B25	VHD1909	SCREW	1	
B26	VHD1909	SCREW	1	
B27	VHD1909	SCREW	1	
B28	VHD1909	SCREW	1	
B29	VHD1909	SCREW	1	
B30	VHD1909	SCREW	1	
B31	VHD2222	SCREW	1	
B32	VHD2222	SCREW	1	
B33	VHD2222	SCREW	1	
B34	VHD2222	SCREW	1	
B35	VHD2222	SCREW	1	
B36	VHD2222	SCREW	1	
B37	VHD2289	SCREW	1	
B38	VHD2289	SCREW	1	
B39	VHD2318	SCREW	1	
B40	VHD2318	SCREW	1	
B41	VHD2318	SCREW	1	
B42	VHD2318	SCREW	1	
B43	VHD2318	SCREW	1	
B44	VHD2336	SCREW	1	
B45	XQN16+BJ4FN	SCREW	1	
B46	XQN16+BJ4FN	SCREW	1	
B48	VHD2322	SCREW	1	[PAVCSG]
B49	VHD2322	SCREW	1	[PAVCSG]
B50	VHD1759	SCREW	1	[PAVCSG]
P	VUMG1980	WATERPROOF PACKING KIT	1	
P-1	-----	CASE O RING	1	(Included in VUMG1980)
P-2	-----	CASE O RING	1	(Included in VUMG1980)
P-3	-----	CASE O RING	1	(Included in VUMG1980)
P-4	-----	CASE O RING	1	(Included in VUMG1980)
P-5	-----	TOP BUTTON PACKING	1	(Included in VUMG1980)
P-6	-----	BATT DOOR PACKING	1	(Included in VUMG1980)
P-7	-----	CASE O RING	1	(Included in VUMG1980)
P-8	-----	REAR BUTTON PACKING	1	(Included in VUMG1980)

DMC-FT3EB-A

Ref.No.	Part No.	Part Name & Description	Pcs	Remarks	Ref.No.	Part No.	Part Name & Description	Pcs	Remarks
301	VPF1386	CAMERA BAG	1	EB,EE,EF,EG,EP,GC,GN,SG, GD,GH,GT,PU	△ 313	VQT3L25	BASIC O/I	1	EG (GERMAN/FRENCH)
302	VPK4968	PACKING CASE	1	EB-A,EG-A,EP-A,GC-A,GN-A, SG-A	△ 313	VQT3L26	BASIC O/I	1	EG (ITALIAN/DUTCH)
302	VPK4964	PACKING CASE	1	EB-R,EF-R,EG-R,EP-R,GC-R, GN-R,SG-R	△ 313	VQT3L27	BASIC O/I	1	EG (SPANISH/PORTUGUESE)
302	VPK4960	PACKING CASE	1	EE-S,EG-S,EP-S,GC-S,GN-S, SG-S	△ 313	VQT3L28	BASIC O/I	1	EG (TURKISH)
302	VPK4971	PACKING CASE	1	EE-D,EF-D,EG-D,EP-D,GC-D, GN-D	△ 313	VQT3L29	BASIC O/I	1	EP (SWEDISH/DANISH)
302	VPK4969	PACKING CASE	1	GD-A,GH-A,PU-A	△ 313	VQT3L30	BASIC O/I	1	EP (POLISH/CZECH)
302	VPK4972	PACKING CASE	1	GD-D,GH-D,GT-D,PU-D	△ 313	VQT3L31	BASIC O/I	1	EP (HUNGARIAN/FINNISH)
302	VPK4961	PACKING CASE	1	GH-S,PU-S	△ 313	VQT3L35	BASIC O/I	1	GC,SG,GH (ENGLISH/ CHINESE(TRADITIONAL))
302	VPK4965	PACKING CASE	1	GT-R,PU-R	△ 313	VQT3L36	BASIC O/I	1	GC (ARABIC/PERSIAN)
△ 303	DE-A60AA	BATTERY CHARGER	1	EB,EF,EG,EP,GN	△ 313	VQT3M16	BASIC O/I	1	GC (VIETNAMESE)
△ 303	DE-A60BB	BATTERY CHARGER	1	EE,GC,GD,GH	△ 313	VQT3L38	BASIC O/I	1	GN (ENGLISH)
△ 303	DE-A60EA	BATTERY CHARGER	1	SG	△ 313	VQT3L39	BASIC O/I	1	GD (KOREAN)
△ 303	DE-A60CA	BATTERY CHARGER	1	GT	△ 313	VQT3L37	BASIC O/I	1	GT (CHINESE(TRADITIONAL))
△ 303	DE-A59BB	BATTERY CHARGER	1	PU	△ 313	VQT3L24	BASIC O/I	1	PU (SPANISH/PORTUGUESE)
△ 304	K2CT39A00002	AC CORD	1	EB,GC,GH	315	VFC4588T	CLEANING BRUSH	1	EB,EE,EF,EG,EP,GC,GN,SG, GD,GH,GT,PU
△ 304	K2CQ29A00002	AC CORD	1	EE,EF,EG,EP,GC	316	VPN7190	CUSHION	1	EB,EE,EF,EG,EP,GC,GN,SG, GD,GH,GT,PU
△ 304	K2CJ29A00002	AC CORD	1	GN					
△ 304	K2CA29A000023	AC CORD	1	SG					
△ 304	K2CR29A00001	AC CORD	1	GD					
△ 304	K2CA29A00021	AC CORD	1	GT					
△ 305	-	BATTERY PACK	1	(NOT SUPPLIED)EB,EE,EF,EG, EP,GC,GN,SG,GD,GH,GT,PU					
306	K1HY08YY0017	USB CABLE	1	EB,EE,EF,EG,EP,GC,GN,SG, GD,GH,GT,PU					
307	K1HY08YY0018	AV CABLE	1	EB,EE,EF,EG,EP,GC,GN,SG, GD,GH,GT,PU					
308	VFF0804-S	CD-ROM (SOFT/INSTRUCTION BOOK)	1	EB,EF,EP See "Notes"					
308	VFF0789-S	CD-ROM (SOFT/INSTRUCTION BOOK)	1	EE See "Notes"					
308	VFF0788-S	CD-ROM (SOFT/INSTRUCTION BOOK)	1	EG See "Notes"					
308	VFF0790-S	CD-ROM (SOFT/INSTRUCTION BOOK)	1	GC,GN,SG,GH See "Notes"					
308	VFF0791-S	CD-ROM (SOFT/INSTRUCTION BOOK)	1	GD,GT See "Notes"					
308	VFF0787-S	CD-ROM (SOFT/INSTRUCTION BOOK)	1	PU See "Notes"					
309	VFC4393	HAND STRAP	1	EB,EE,EF,EG,EP,GC,GN,SG, GD,GH,GT,PU					
310	VMG1988	SILICONE JACKET	1	GN					
311	VPF1230	POLYETHYLENE BAG	1	EB,EE,EF,EG,EP,GC,GN,SG, GD,GH,GT,PU					
312	VQC8094	O/I SOFTWARE	1	EB,GN (ENGLISH)					
312	VQC8095	O/I SOFTWARE	1	EE (RUSSIAN/UKRAINIAN)					
312	VQC8093	O/I SOFTWARE	1	EF (FRENCH)					
312	VQC8091	O/I SOFTWARE	1	EG (GERMAN/ITALIAN/FRENCH/ DUTCH/SPANISH/ PORTUGUESE/TURKISH)					
312	VQC8092	O/I SOFTWARE	1	EP (FINNISH/SWEDISH/DANISH/ POLISH/CZECH/HUNGARIAN)					
312	VQC8096	O/I SOFTWARE	1	GC,SG,GH (ENGLISH/ CHINESE(TRADITIONAL)/ ARABIC/PERSIAN)					
312	VQC8099	O/I SOFTWARE	1	GD (KOREAN)					
312	VQC8097	O/I SOFTWARE	1	GT (CHINESE(TRADITIONAL))					
312	VQC8090	O/I SOFTWARE	1	PU (SPANISH/PORTUGUESE)					
△ 313	VQT3L33	BASIC O/I	1	EB (ENGLISH)					
△ 313	VQT3L34	BASIC O/I	1	EE (RUSSIAN/UKRAINIAN)					
△ 313	VQT3L32	BASIC O/I	1	EF (FRENCH)					

S7. Exploded View

S7.1. Frame and Casing Section

From Ref No. "P-1" to "P-8" are supplied as a "waterproof packing kit" (Part No. VUMG1980), and are Not supplied individually. ("P-6" is also included in Ref. 37.)

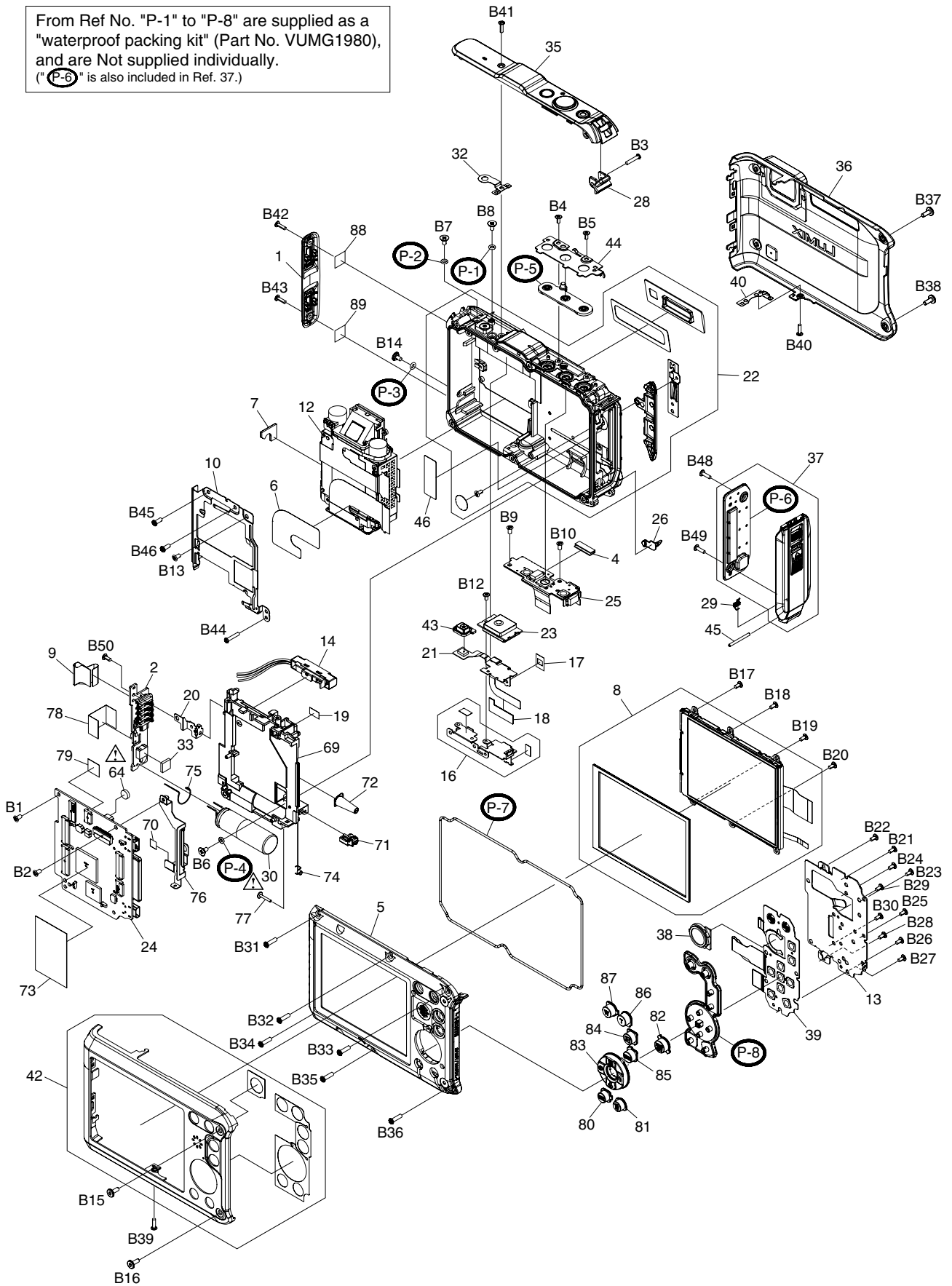

S7.2. Packing Parts and Accessories Section (1)

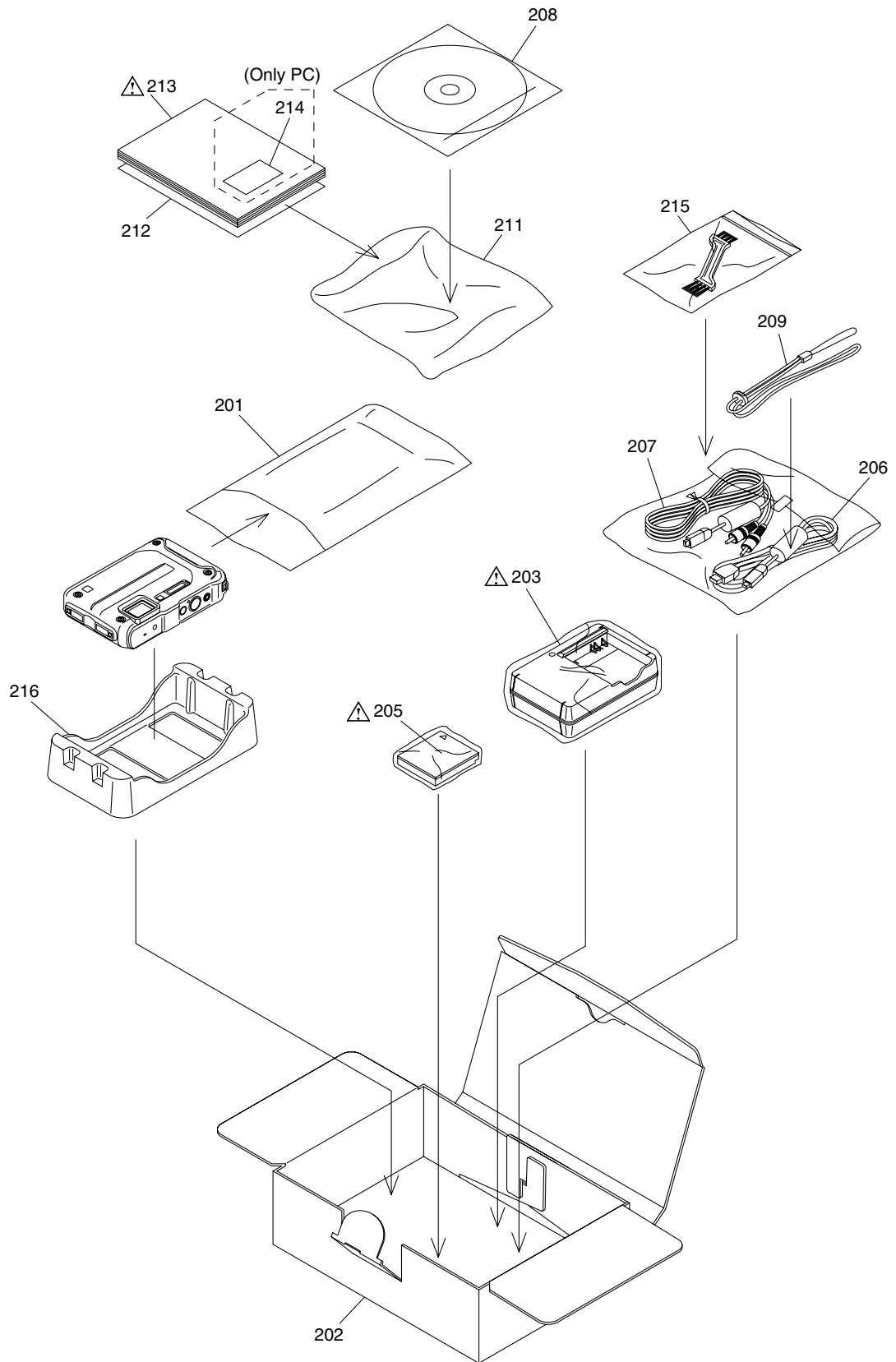

S7.3. Packing Parts and Accessories Section (2)

