

Service Manual

Digital Camera

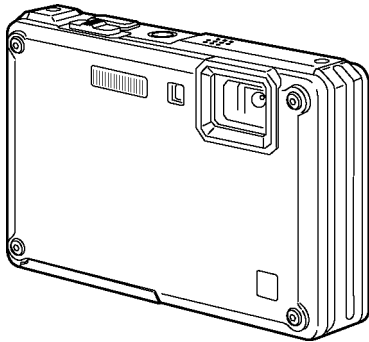

- Model No. **DMC-FT1EB**
DMC-FT1EE
DMC-FT1EF
DMC-FT1EG
DMC-FT1EP
DMC-FT1GC
DMC-FT1GJ
DMC-FT1GN
DMC-FT1SG
DMC-TS1P
DMC-TS1PC
DMC-TS1PU
DMC-TS1GH
DMC-TS1GK
DMC-TS1GT

VOL.1

Colours

- (A).....Blue Type (only DMC-FT1EB/EF/EG/EP/
GC/GN, DMC-TS1PC/PU)
(D).....Orange Type (Except DMC-FT1EB)
(G).....Green Type (Except DMC-FT1EB)
(S).....Silver Type (Except DMC-FT1EF, DMC-
TS1GT)

⚠ WARNING

This service information is designed for experienced repair technicians only and is not designed for use by the general public. It does not contain warnings or cautions to advise non-technical individuals of potential dangers in attempting to service a product. Products powered by electricity should be serviced or repaired only by experienced professional technicians. Any attempt to service or repair the product or products dealt with in this service information by anyone else could result in serious injury or death.

Panasonic®

©Panasonic Corporation 2009.
Unauthorized copying and distribution is a violation
of law.

TABLE OF CONTENTS

	PAGE	PAGE
1 Safety Precautions	3	
1.1. General Guidelines	3	
1.2. Leakage Current Cold Check	3	
1.3. Leakage Current Hot Check (See Figure 1).....	3	
1.4. How to Discharge the Capacitor on Flash PCB.....	4	
2 Warning	5	
2.1. Prevention of Electrostatic Discharge (ESD) to Electrostatic Sensitive (ES) Devices	5	
2.2. How to Recycle the Lithium Ion Battery (U.S. Only).....	5	
2.3. Caution for AC Cord (For EB/GC/GH).....	6	
2.4. How to Replace the Lithium Battery.....	7	
3 Service Navigation	9	
3.1. Introduction	9	
3.2. Air-leak test (inspection).....	9	
3.3. Replacing the waterproof packing (waterproof seal)	9	
3.4. Lens Unit	9	
3.5. General Description About Lead Free Solder (PbF)	9	
3.6. Important Notice 1:(Other than U.S.A. and Canadian Market)	10	
3.7. How to Define the Model Suffix.....	11	
4 Specifications	15	
5 Location of Controls and Components	21	
6 Service Mode	23	
6.1. Error Code Memory Function	23	
6.2. ICS (Indication of additional Camera Settings when picture was taken) function	26	
7 Troubleshooting Guide	28	
7.1. Service and Check Procedures	28	
7.2. Air-leak Test	31	
7.3. Air-leak Test (Inspection).....	32	
8 Service Fixture & Tools	34	
8.1. Service Fixture and Tools	34	
8.2. When Replacing the Main PCB	35	
8.3. Service Position	35	
9 Disassembly and Assembly Instructions	37	
9.1. Disassembly Flow Chart.....	37	
9.2. PCB Location.....	37	
9.3. Disassembly Procedures.....	38	
10 Measurements and Adjustments	48	
10.1. Matrix Chart for Replaced Part and Necessary Adjustment.....	48	
11 Maintenance	49	
11.1. Cleaning Lens and LCD Panel	49	

1 Safety Precautions

1.1. General Guidelines

1. IMPORTANT SAFETY NOTICE

There are special components used in this equipment which are important for safety. These parts are marked by \triangle in the Schematic Diagrams, Circuit Board Layout, Exploded Views and Replacement Parts List. It is essential that these critical parts should be replaced with manufacturer's specified parts to prevent X-RADIATION, shock fire, or other hazards. Do not modify the original design without permission of manufacturer.

2. An Isolation Transformer should always be used during the servicing of AC Adaptor whose chassis is not isolated from the AC power line. Use a transformer of adequate power rating as this protects the technician from accidents resulting in personal injury from electrical shocks. It will also protect AC Adaptor from being damaged by accidental shorting that may occur during servicing.
3. When servicing, observe the original lead dress. If a short circuit is found, replace all parts which have been overheated or damaged by the short circuit.
4. After servicing, see to it that all the protective devices such as insulation barriers, insulation papers shields are properly installed.
5. After servicing, make the following leakage current checks to prevent the customer from being exposed to shock hazards.

1.2. Leakage Current Cold Check

1. Unplug the AC cord and connect a jumper between the two prongs on the plug.
2. Measure the resistance value, with an ohmmeter, between the jumpered AC plug and each exposed metallic cabinet part on the equipment such as screwheads, connectors, control shafts, etc. When the exposed metallic part has a return path to the chassis, the reading should be between $1M\Omega$ and $5.2M\Omega$. When the exposed metal does not have a return path to the chassis, the reading must be infinity.

1.3. Leakage Current Hot Check (See Figure 1)

1. Plug the AC cord directly into the AC outlet. Do not use an isolation transformer for this check.
2. Connect a $1.5k\Omega$, 10 W resistor, in parallel with a $0.15\mu F$ capacitor, between each exposed metallic part on the set and a good earth ground, as shown in Figure 1.
3. Use an AC voltmeter, with $1 k\Omega/V$ or more sensitivity, to measure the potential across the resistor.
4. Check each exposed metallic part, and measure the voltage at each point.
5. Reverse the AC plug in the AC outlet and repeat each of the above measurements.
6. The potential at any point should not exceed 0.75 V RMS. A leakage current tester (Simpson Model 229 or equivalent) may be used to make the hot checks, leakage current must not exceed $1/2$ mA. In case a measurement is outside of the limits specified, there is a possibility of a shock hazard, and the equipment should be repaired and rechecked before it is returned to the customer.

Hot-Check Circuit

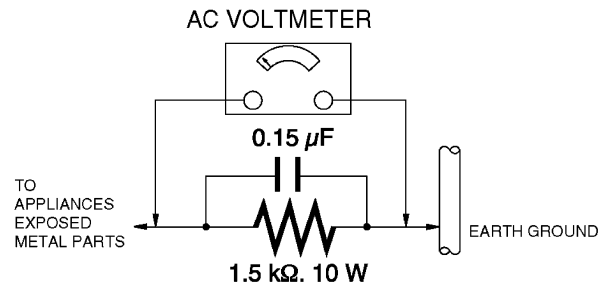

Figure 1

1.4. How to Discharge the Capacitor on Flash PCB

- This unit equipped with two pieces of capacitors as flash charging capacitors.
"Either one of the capacitor discharging operation" makes discharging for others as well.

CAUTION:

1. **Be sure to discharge the capacitor on FLASH PCB.**
2. **Be careful of the high voltage circuit on FLASH PCB when servicing.**

[Discharging Procedure]

1. Refer to the disassemble procedure and remove the necessary parts/unit.
2. Put the insulation tube onto the lead part of Resistor (ERG5SJ102:1k Ω /5W).
(An equivalent type of resistor may be used.)
3. Put the resistor between both terminals of capacitor on FLASH PCB for approx. 5 seconds.
4. After discharging confirm that the capacitor voltage is lower than 10V using a voltmeter.

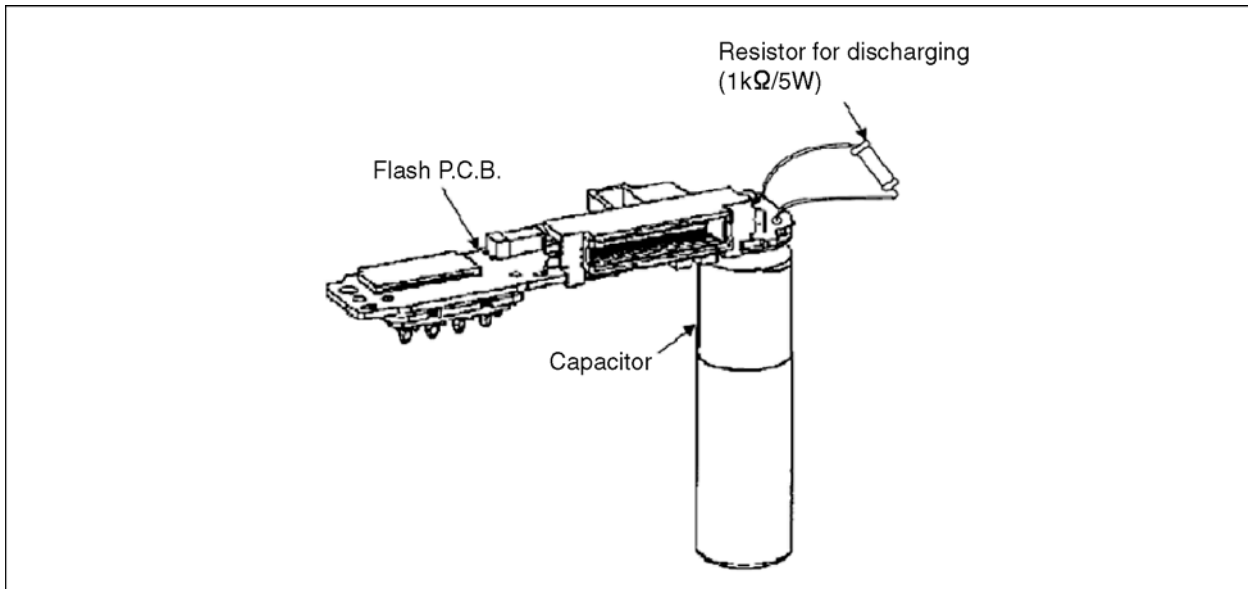

Fig. F1

2 Warning

2.1. Prevention of Electrostatic Discharge (ESD) to Electrostatic Sensitive (ES) Devices

Some semiconductor (solid state) devices can be damaged easily by static electricity. Such components commonly are called Electrostatically Sensitive (ES) Devices.

Examples of typical ES devices are CCD image sensor, IC (integrated circuits) and some field-effect transistors and semiconductor "chip" components.

The following techniques should be used to help reduce the incidence of component damage caused by electrostatic discharge (ESD).

1. Immediately before handling any semiconductor component or semiconductor-equipped assembly, drain off any ESD on your body by touching a known earth ground. Alternatively, obtain and wear a commercially available discharging ESD wrist strap, which should be removed for potential shock reasons prior to applying power to the unit under test.
2. After removing an electrical assembly equipped with ES devices, place the assembly on a conductive surface such as aluminum foil, to prevent electrostatic charge buildup or exposure of the assembly.
3. Use only a grounded-tip soldering iron to solder or unsolder ES devices.
4. Use only an antistatic solder removal device. Some solder removal devices not classified as **antistatic (ESD protected)** can generate electrical charge sufficient to damage ES devices.
5. Do not use freon-propelled chemicals. These can generate electrical charges sufficient to damage ES devices.
6. Do not remove a replacement ES device from its protective package until immediately before you are ready to install it. (Most replacement ES devices are packaged with leads electrically shorted together by conductive foam, aluminum foil or comparable conductive material).
7. Immediately before removing the protective material from the leads of a replacement ES device, touch the protective material to the chassis or circuit assembly into which the device will be installed.

CAUTION:

Be sure no power is applied to the chassis or circuit, and observe all other safety precautions.

8. Minimize bodily motions when handling unpackaged replacement ES devices. (Otherwise harmless motion such as the brushing together of your clothes fabric or the lifting of your foot from a carpeted floor can generate static electricity (ESD) sufficient to damage an ES device).

2.2. How to Recycle the Lithium Ion Battery (U.S. Only)

ENGLISH



A lithium ion/polymer battery that is recyclable powers the product you have purchased. Please call 1-800-8-BATTERY for information on how to recycle this battery.

FRANÇAIS



L'appareil que vous vous êtes procuré est alimenté par une batterie au lithium-ion/polymère recyclable. Pour des renseignements sur le recyclage de la batterie, veuillez composer le 1-800-8-BATTERY.

2.3. Caution for AC Cord (For EB/GC/GH)

2.3.1. Information for Your Safety

IMPORTANT

Your attention is drawn to the fact that recording of pre-recorded tapes or discs or other published or broadcast material may infringe copyright laws.

WARNING

To reduce the risk of fire or shock hazard, do not expose this equipment to rain or moisture.

CAUTION

To reduce the risk of fire or shock hazard and annoying interference, use the recommended accessories only.

FOR YOUR SAFETY

DO NOT REMOVE THE OUTER COVER

To prevent electric shock, do not remove the cover. No user serviceable parts inside. Refer servicing to qualified service personnel.

2.3.2. Caution for AC Mains Lead

For your safety, please read the following text carefully.

This appliance is supplied with a moulded three-pin mains plug for your safety and convenience.

A 5-ampere fuse is fitted in this plug.

Should the fuse need to be replaced please ensure that the replacement fuse has a rating of 5 amperes and it is approved by ASTA or BSI to BS1362

Check for the ASRA mark or the BSI mark on the body of the fuse.



If the plug contains a removable fuse cover you must ensure that it is refitted when the fuse is replaced.

If you lose the fuse cover, the plug must not be used until a replacement cover is obtained.

A replacement fuse cover can be purchased from your local Panasonic Dealer.

If the fitted moulded plug is unsuitable for the socket outlet in your home then the fuse should be removed and the plug cut off and disposed of safely.

There is a danger of severe electrical shock if the cut off plug is inserted into any 13-ampere socket.

If a new plug is to be fitted please observe the wiring code as shown below.

If in any doubt, please consult a qualified electrician.

2.3.2.1. Important

The wires in this mains lead are coloured in accordance with the following code:

Blue	Neutral
Brown	Live

As the colours of the wires in the mains lead of this appliance may not correspond with the coloured markings identifying the terminals in your plug, proceed as follows:

The wire which is coloured BLUE must be connected to the terminal in the plug which is marked with the letter N or coloured BLACK.

The wire which is coloured BROWN must be connected to the terminal in the plug which is marked with the letter L or coloured RED.

Under no circumstances should either of these wires be connected to the earth terminal of the three pin plug, marked with the letter E or the Earth Symbol.

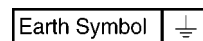

2.3.2.2. Before Use

remove the Connector Cover as follows.

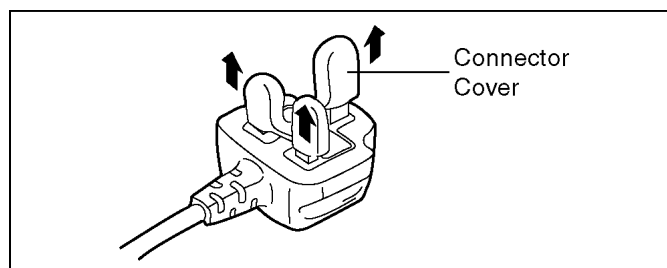

2.3.2.3. How to Replace the Fuse

1. Remove the Fuse Cover with a screwdriver.

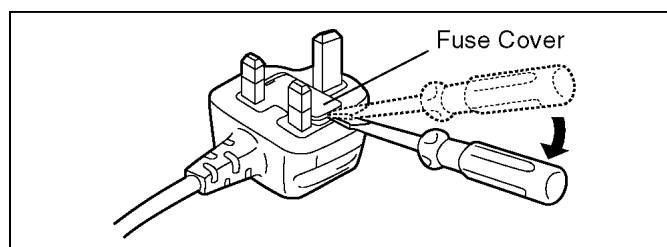

2. Replace the fuse and attach the Fuse cover.

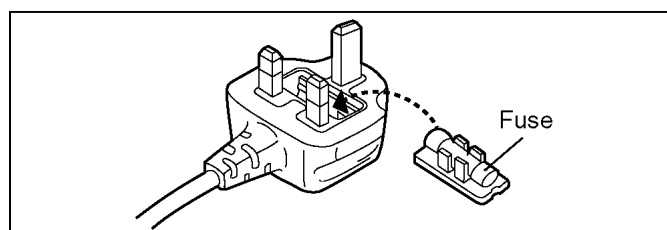

2.4. How to Replace the Lithium Battery

2.4.1. Replacement Procedure

1. Remove the Rear Operation PCB. (Refer to Disassembly Procedures.)
2. Remove the Lithium battery (Ref. No. **B6402** at foil side of Rear Operation PCB) and then replace it into new one.

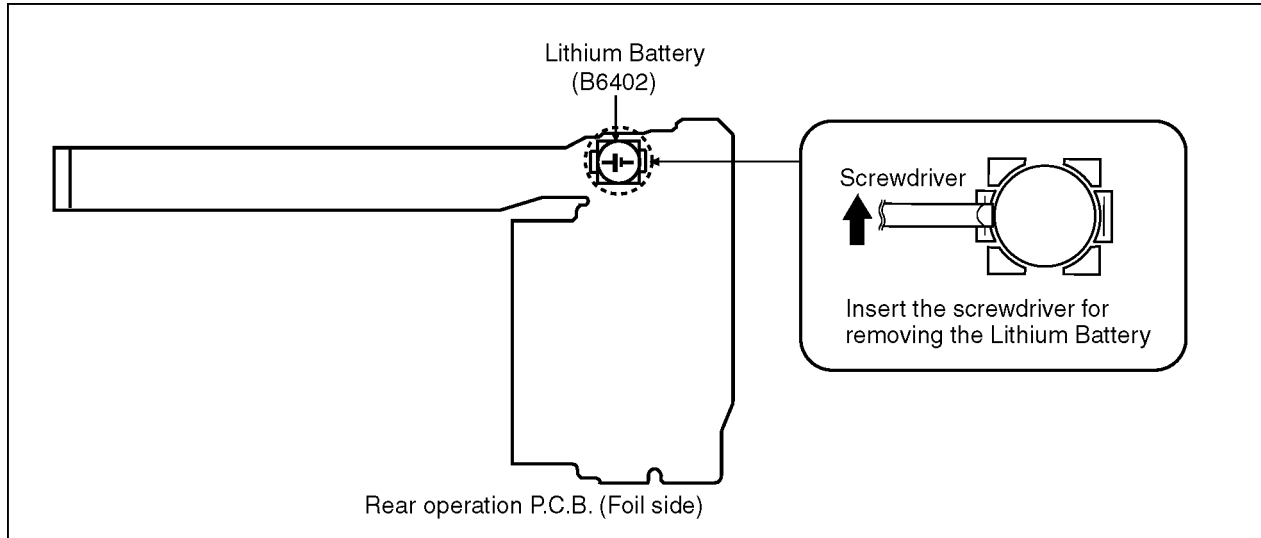

CAUTION

Danger of explosion if battery is incorrectly replaced.
Replace only with the same or equivalent type.

CAUTION

The battery used in this device may present a risk of fire or chemical burn if mistreated.
Do not recharge, disassemble, heat above 100° C (212° F), or incinerate.
Replace battery with Panasonic part number ML-421S/ZTK only.
Use of another battery may present a risk of fire or explosion.
Dispose of used battery promptly.
Keep away from children.
Do not disassemble and do not dispose of in fire.

Note:

The lithium battery is a critical component.

(Type No.: ML-421S/ZTK **Manufactured by Energy Company, Panasonic Corporation**)

It must never be subjected to excessive heat or discharge.

It must therefore only be fitted in equipment designed specifically for its use.

Replacement batteries must be of the same type and manufacture.

They must be fitted in the same manner and location as the original battery, with the correct polarity contacts observed.

Do not attempt to re-charge the old battery or re-use it for any other purpose.

It should be disposed of in waste products destined for burial rather than incineration.

(For English)

CAUTION

Danger of explosion if battery is incorrectly replaced.
Replace only with the same or equivalent type recommended by the manufacturer.
Dispose of used batteries according to the manufacturer's instructions.

(For German)

ACHTUNG

Explosionsgefahr bei falschem Anbringen der Batterie. Ersetzen Sie nur mit einem äquivalentem vom Hersteller empfohlenem Typ.
Behandeln Sie gebrauchte Batterien nach den Anweisungen des Herstellers.

(For French)

MISE EN GARDE

Une batterie de remplacement inappropriée peut exploser. Ne remplacez qu'avec une batterie identique ou d'un type recommandé par le fabricant. L'élimination des batteries usées doit être faite conformément aux instructions du fabricant.

NOTE:

Above caution is applicable for a battery pack which is for DMC-FT1 and DMC-TS1 series, as well.
Danger of explosion if battery is incorrectly replaced.
Replace only with the same or equivalent type recommended by the manufacturer.
Dispose of used batteries according to the manufacturer's instructions.

3 Service Navigation

3.1. Introduction

This service manual contains technical information, which will allow service personnel's to understand and service this model. Please place orders using the parts list and not the drawing reference numbers. If the circuit is changed or modified, the information will be followed by service manual to be controlled with original service manual.

3.2. Air-leak test (inspection)

- This product was tested using Panasonic's internal test standard, which is in accordance with :
Waterproof/Dustproof : IEC60529 IP58, certified to a depth of 3.0 m (60 minutes),
Shockproof : MIL-STD-810F Method 516.5-Shock, compliant to a height of 1.5 m.
- Due to the characteristics of the products, perform the air-leak test (inspection) using Air -leak tester (Part No.:RFKZ0528) before/after servicing including assembly and/or assembly process.

NOTE:

The purpose of the air-leak test before servicing is that whether the malfunction occurred due to air-leak or not.

- When servicing, refer to the "7.Troubleshooting" section in details.

3.3. Replacing the waterproof packing (waterproof seal)

- The integrity of the waterproof packing may decrease about 1 year, with use and age.
(We recommend end users to replace the waterproof packing (waterproof seal) at least once each year described in the operating instructions.)
- As for replacement procedure, refer to the 7.1.2.Periodical maintenance (Packing replacement) flow in details.

3.4. Lens Unit

Since the lens unit for this model is assembled with high accuracy manufacturing technologies, it is not allowed to disassemble/assemble the lens unit, in terms of performance retention.

When servicing, it has to be handled the "Lens with CCD unit" as the smallest part size.

Refer to each section, disassembly/assembly procedure, exploded views and replacement parts list replacement parts list for lens part, in details.

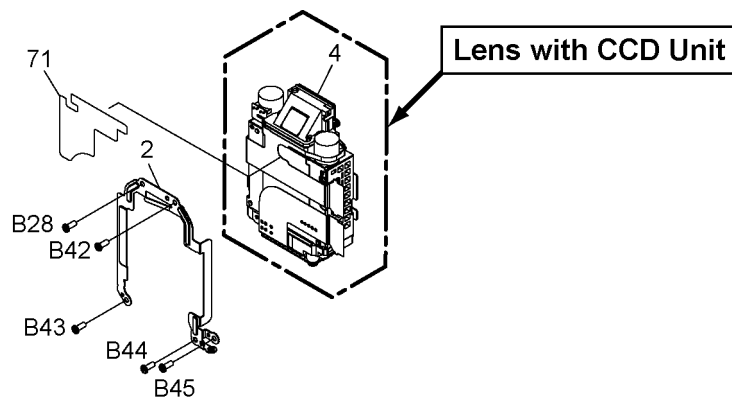

3.5. General Description About Lead Free Solder (PbF)

The lead free solder has been used in the mounting process of all electrical components on the printed circuit boards used for this equipment in considering the globally environmental conservation.

The normal solder is the alloy of tin (Sn) and lead (Pb). On the other hand, the lead free solder is the alloy mainly consists of tin (Sn), silver (Ag) and Copper (Cu), and the melting point of the lead free solder is higher approx.30 °C (86 °F) more than that of the normal solder.

Definition of PCB Lead Free Solder being used

The letter of **PbF** is printed either foil side or components side on the PCB using the lead free solder.
(See right figure)

PbF

Service caution for repair work using Lead Free Solder (PbF)

- The lead free solder has to be used when repairing the equipment for which the lead free solder is used.
- (Definition: The letter of **PbF** is printed on the PCB using the lead free solder.)
- To put lead free solder, it should be well molten and mixed with the original lead free solder.
- Remove the remaining lead free solder on the PCB cleanly for soldering of the new IC.
- Since the melting point of the lead free solder is higher than that of the normal lead solder, it takes the longer time to melt the

lead free solder.

- Use the soldering iron (more than 70W) equipped with the temperature control after setting the temperature at 350±30 degrees C (662±86 °F).

Recommended Lead Free Solder (Service Parts Route.)

- The following 3 types of lead free solder are available through the service parts route.
 - RFKZ03D01KS------(0.3mm 100g Reel)
 - RFKZ06D01KS------(0.6mm 100g Reel)
 - RFKZ10D01KS------(1.0mm 100g Reel)

Note

* Ingredient: tin (Sn) 96.5%, silver (Ag) 3.0%, Copper (Cu) 0.5%, Cobalt (Co) / Germanium (Ge) 0.1 to 0.3%

3.6. Important Notice 1:(Other than U.S.A. and Canadian Market)

1. The service manual does not contain the following information, because of the impossibility of servicing at component level without concerned equipment/facilities.

- a. Schematic diagram, Block Diagram and PCB layout of MAIN PCB.
- b. Parts list for individual parts for MAIN PCB.

When a part replacement is required for repairing MAIN PCB, replace as an assembled parts. (MAIN PCB)

2. The following category is/are recycle module part. please send it/them to Central Repair Center.

- MAIN PCB (VEP56072B) : For EB, EF, EG, EP.
- MAIN PCB (VEP56072A) : For EE, GC, GJ, GN, GH, GK, GT, P, PC, PU, SG.

3.7. How to Define the Model Suffix







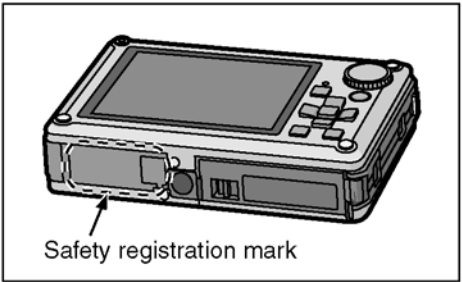

There are eight kinds of DMC-FT1/TS1, regardless of the colours.

- a) DMC-FT1 (Japan domestic model.)/SG
- b) DMC-TS1P/PC
- c) DMC-FT1EB/EF/EG/EP
- d) DMC-FT1EE
- e) DMC-TS1GT
- f) DMC-FT1GN
- g) DMC-TS1GK
- h) DMC-FT1GC/GJ, DMC-TS1GH/PU

What is the difference is that the "INITIAL SETTINGS" data which is stored in Flash ROM mounted on Main PCB.

3.7.1. Defining methods

To define the model suffix to be serviced, refer to the nameplate which is putted on the bottom side of the Unit.

<p>a) DMC-FT1 (Japan domestic model), DMC-FT1SG The nameplate for this model shows the following Safety registration mark.</p>	 <p>Safety registration mark</p>
	
<p>b) DMC-TS1P/PC The nameplate for these models show the following Safety registration mark.</p>	
	
<p>c) DMC-FT1EB/EF/EG/EP The nameplate for these models show the following Safety registration mark.</p>	
	
<p>d) DMC-FT1EE The nameplate for this model show the following Safety registration mark.</p>	
	
<p>e) DMC-TS1GT The nameplate for this model show the following Safety registration mark.</p>	
	
<p>f) DMC-FT1GN The nameplate for this model show the following Safety registration mark.</p>	
	
<p>g) DMC-TS1GK The nameplate for this model show the following Safety registration mark.</p>	
	
<p>h) DMC-FT1GC/GJ, DMC-TS1GH/PU The nameplate for these models do not show any above safety registration mark.</p>	

NOTE:

After replacing the MAIN PCB, be sure to achieve adjustment.

The adjustment instruction is available at "software download" on the "Support Information from NWBG/VDBG-AVC" web-site in "TSN system", together with Maintenance software.

3.7.2. INITIAL SETTINGS:

After replacing the MAIN PCB, be sure to perform the initial settings after achieving the adjustment by ordering the following procedure in accordance with model suffix of the unit.

1. IMPORTANT NOTICE:

Before proceeding Initial settings, be sure to read the following CAUTIONS.

CAUTION 1:(INITIAL SETTINGS)

---AFTER REPLACING THE MAIN P.C.B. ---

[Other than "EG, EP, EF and EB" models : (VEP56072A is used as a Main P.C.B.)]

*.The model suffix can be chosen **JUST ONE TIME.**

(Effective model suffix : DMC-FT1 " EE/GC/GJ/GN/SG ")

DMC-TS1 " GH/GK/GT/P/PC/PU")

*.Once one of the model suffix has been chosen, the model suffix lists will not be displayed, thus, it can not be changed.

[Only for "EG, EP, EF and EB" models : (VEP56072B is used as a Main P.C.B.)]

*.From the beginning, only "EB, EF, EG, and EP" are displayed as a model suffix lists, and these are displayed from the second times as well.

CAUTION 2:(Stored picture image data in the unit)

This unit employs "Built-in Memory" for picture image data recording.(Approx.40MB)

After proceeding "INITIAL SETTINGS", the picture image data stored in the unit is erased.

2. PROCEDURES:

- Precautions: Read the above "CAUTION 1" and "CAUTION 2", carefully
- Preparation:
 1. Attach the Battery or AC Adaptor with a DC coupler to the unit.
 2. Set the mode dial to the NORMAL PICTURE mode.

NOTE:

If the mode dial position is other than NORMAL PICTURE mode, it does not display the initial settings menu.

• Step 1. The temporary cancellation of "INITIAL SETTINGS":

While keep pressing "UP of Cursor button" and DISPLAY button simultaneously, turn the Power on.

• Step 2. The cancellation of "INITIAL SETTINGS":

Press the PLAYBACK button.

Press "UP of Cursor button" and DISPLAY button simultaneously, then turn the Power off.

• Step 3. Turn the Power on:

Turn the Power on.

• Step 4. Display the "INITIAL SETTINGS" menu:

NOTE:

If the unit is other than NORMAL PICTURE mode, it does not display the initial settings menu.

While keep pressing MENU/SET and "RIGHT of Cursor button" simultaneously, turn the Power off.

The "INITIAL SETTINGS" menu is displayed.

There are two kinds of "INITIAL SETTINGS" menu form as follows:

[CASE 1. After replacing MAIN P.C.B.]

[Other than "EG, EP, EF and EB" models : (VEP56072A is used as a Main P.C.B.)]

When MAIN P.C.B. has just been replaced, all of the model suffix are displayed as follows. (Four pages in total)

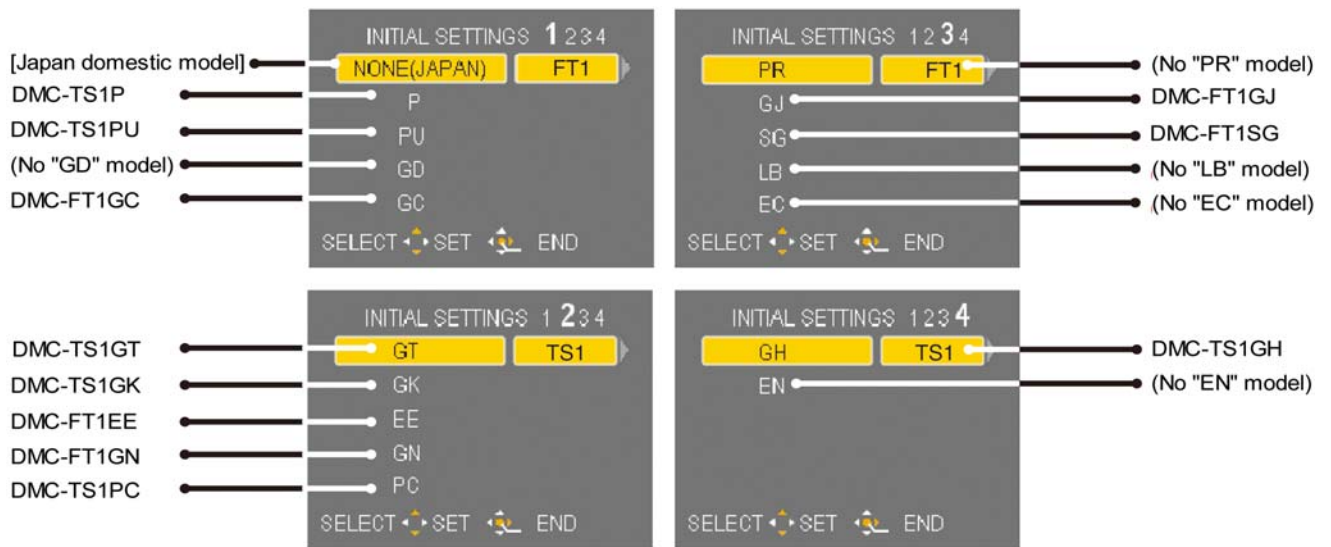

[Only for "EG, EP, EF and EB" models : (VEP56072B is used as a Main P.C.B.)]

When MAIN P.C.B. has just been replaced, only 4 model suffix are displayed as follows.



[CASE 2. Other than "After replacing MAIN P.C.B."]



• Step 5. Chose the model suffix in "INITIAL SETTINGS": (Refer to "CAUTION 1")

[Caution: After replacing MAIN P.C.B.]

(Especially, other than "EG, EP, EF and EB" models : (VEP56072A is used as a Main P.C.B.))

The model suffix can be chosen, JUST ONE TIME.

Once one of the model suffix have been chosen, the model suffix lists will not be displayed, thus, it can be changed.

Therefore, select the area carefully.

Select the area with pressing "UP / DOWN" of Cursor buttons".

• Step 6. Set the model suffix at "INITIAL SETTINGS":

Press the "RIGHT" of Cursor buttons".

The only set area is displayed. Press the "RIGHT" of Cursor buttons" after confirmation.

(The unit is powered off automatically.)

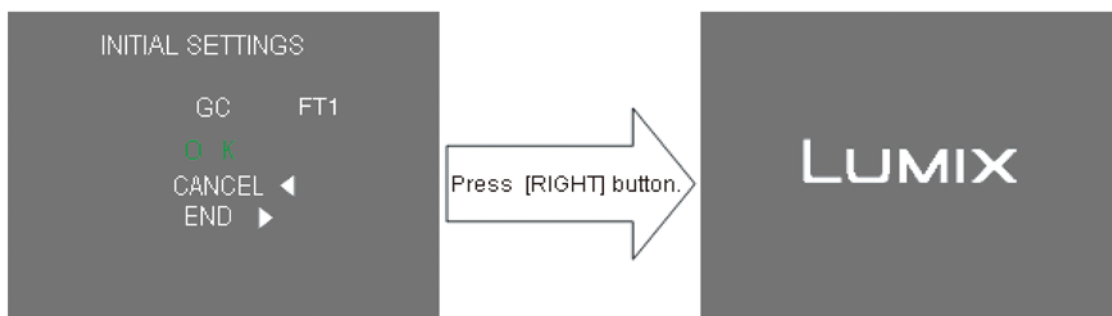

• **Step 7. CONFIRMATION:**

Confirm the display of "PLEASE SET THE CLOCK" in concerned language when the unit is turned on again.

When the unit is connected to PC with USB cable, it is detected as removable media.

1) As for your reference, major default setting condition is as shown in the following table.

Default setting (After "INITIAL SETTINGS")

	MODEL	VIDEO OUTPUT	LANGUAGE	DATE	REMARKS
a)	DMC-FT1(Japan domestic model)	NTSC	Japanese	Year/Month/Date	
b)	DMC-FT1EB	PAL	English	Date/Month/Year	
c)	DMC-FT1EE	PAL	Russian	Date/Month/Year	
d)	DMC-FT1EF	PAL	French	Date/Month/Year	
e)	DMC-FT1EG	PAL	English	Date/Month/Year	
f)	DMC-FT1EP	PAL	English	Date/Month/Year	
g)	DMC-FT1GC	PAL	English	Date/Month/Year	
h)	DMC-FT1GJ	PAL	Thai	Date/Month/Year	
i)	DMC-FT1GN	PAL	English	Date/Month/Year	
j)	DMC-FT1SG	PAL	English	Date/Month/Year	
k)	DMC-TS1GH	PAL	English	Date/Month/Year	
l)	DMC-TS1GK	PAL	Chinese (simplified)	Year/Month/Date	No Underwater mode
m)	DMC-TS1GT	NTSC	Chinese (Traditional)	Year/Month/Date	
n)	DMC-TS1P	NTSC	English	Date/Month/Year	
o)	DMC-TS1PC	NTSC	English	Date/Month/Year	
p)	DMC-TS1PU	NTSC	Spanish	Date/Month/Year	

4 Specifications

Digital Camera:	Information for your safety
Power Source:	DC 5.1 V
Power Consumption:	1.35 W (When recording) 0.7 W (When playing back)
Camera effective pixels:	12,100,000 pixels
Image sensor:	1/2.33" CCD, total pixel number 12,700,000 pixels, Primary color filter
Lens:	Optical 4.6×zoom, f=4.9 mm to 22.8 mm (35 mm film camera equivalent: 28 mm to 128 mm)/F3.3 to F5.9
Digital zoom:	Max. 4×
Extended optical zoom:	Max. 9.1×
Focus:	Normal/AF Macro/Macro zoom/Face detection/AF Tracking/ 11-area-focusing/1-area-focusing (High speed)/ 1-area-focusing/Spot-focusing
Focus range:	Normal: 30 cm (0.99 feet) to ∞ Macro/Intelligent auto/Clipboard Mode: 5 cm (0.17 feet) (Wide)/30 cm (0.99 feet) (Tele) to ∞ Scene mode: There may be differences in the above settings.
Shutter system:	Electronic shutter+Mechanical shutter
Burst recording	
Burst speed:	Approx. 2.3 pictures/second (Normal), Approx. 1.8 pictures/second (Unlimited)
Number of recordable pictures:	Max. 5 pictures (Standard), max. 3 pictures (Fine), Depends on the remaining capacity of the built-in memory or the card (Unlimited). (Performance in burst recording is only with SD Memory Card/SDHC Memory Card. MultiMediaCard performance will be less.)
Hi-speed burst	
Burst speed:	Approx. 10 pictures/second (Speed priority) Approx. 6 pictures/second (Image priority) (3M (4:3), 2.5M (3:2) or 2M (16:9) is selected as the picture size.)
Number of recordable pictures:	When using the built-in memory: Approx. 15 pictures (immediately after formatting) When using a Card: Max. 100 pictures (differs depending on the type of Card and the recording conditions)
ISO sensitivity:	AUTO/80/100/200/400/800/1600 [HIGH SENS.] Mode: 1600 to 6400
Shutter speed:	8 seconds to 1/1300th of a second [STARRY SKY] Mode: 15 seconds, 30 seconds, 60 seconds

White balance:	Auto white balance/Daylight/Cloudy/Shade/Incandescent lights/White set
Exposure (AE):	Program AE Exposure compensation (1/3 EV Step, -2 EV to +2 EV)
Metering Mode:	Multiple
LCD monitor:	2.7" TFT LCD (Approx. 230,000 dots) (field of view ratio about 100%)
Flash:	Flash range: [ISO AUTO] Approx. 30 cm (0.99 feet) to 5.1 m (16.7 feet) (Wide) AUTO, AUTO/Red-eye reduction, Forced flash ON (Forced ON/Red-eye reduction), Slow sync./Red-eye reduction, Forced flash OFF
Microphone:	Monaural
Speaker:	Monaural
Recording media:	Built-in Memory (Approx. 40 MB)/SD Memory Card/SDHC Memory Card/MultiMediaCard (Still pictures only)
Picture size	
Still picture:	When the aspect ratio setting is [4:3] 4000×3000 pixels, 3264×2448 pixels, 2560×1920 pixels, 2048×1536 pixels, 1600×1200 pixels, 640×480 pixels When the aspect ratio setting is [3:2] 4000×2672 pixels, 3264×2176 pixels, 2560×1712 pixels, 2048×1360 pixels When the aspect ratio setting is [16:9] 4000×2248 pixels, 3264×1840 pixels, 2560×1440 pixels, 1920×1080 pixels
Motion pictures:	[AVCHD Lite] (With audio) When set to [SH]: 1280×720 pixels (60p recording*/17 Mbps, only when card is used) When set to [H]: 1280×720 pixels (60p recording*/13 Mbps, only when card is used) When set to [L]: 1280×720 pixels (60p recording*/9 Mbps, only when card is used) * CCD output is at 30 fps [MOTION JPEG] (With audio) When set to [HD]: 1280×720 pixels (30 frames / sec., only when card is used) / When set to [WVGA]: 848×480 pixels (30 frames / sec., only when card is used) / When set to [VGA]: 640×480 pixels (30 frames / sec., only when card is used) / When set to [QVGA]: 320×240 pixels (30 frames / sec.)
Quality:	Fine/Standard
Recording file format	
Still Picture:	JPEG (based on "Design rule for Camera File system", based on "Exif 2.21" standard)/DPOF corresponding
Pictures with audio:	JPEG (based on "Design rule for Camera File system", based on "Exif 2.21" standard)+ "QuickTime" (pictures with audio)
Motion pictures with audio:	AVCHD Lite/QuickTime Motion JPEG



Interface	
Digital:	“USB 2.0” (High Speed)
Analog video/audio:	NTSC, Audio line output (monaural)
Terminal	
[AV/DIGITAL/MULTI]:	Dedicated jack (14 pin)
[HDMI]:	MiniHDMI TypeC
Dimensions:	Approx. 98.3 mm (W)×63.1 mm (H)×23.0 mm (D) [3 14/16” (W)×2 2/4”(H)×7/8” (D)] (excluding the projecting parts)
Mass (weight)	Approx. 162.5 g/5.73 oz (excluding card and battery) Approx. 183.8 g/6.48 oz (with card and battery)
Operating temperature:	0 °C to 40 °C (32 °F to 104 °F)
Operating humidity:	10% to 80%
Waterproof performance:	Equivalent to IEC 60529 “IPX8”. (Usable for 60 minutes in 3 m (10 feet) water depth)
Crash resistance performance:	The camera has cleared a single unit drop test from a height of 1.5 m (5 feet) onto 5 cm (0.17 feet) plywood, which is compliant with “MIL-STD 810F Method 516.5-Shock”.
Dustproof performance:	Equivalent to IEC 60529 “IP5X”.
Battery Charger	
(Panasonic DE-A59B):	Information for your safety
Input:	110 V to 240 V ~ 50/60 Hz, 0.2 A
Output:	CHARGE 4.2 V = 0.65 A
Equipment mobility:	Movable
Battery Pack (lithium-ion)	
(Panasonic DMW-BCF10):	Information for your safety
Voltage/capacity (Minimum):	3.6 V/940 mAh

NOTE:





(Only for "EB/EF/EG/EP" models)

- Data from the PC can not be written to the camera using the USB connection cable.
- Motion pictures can be recorded continuously for up to 15minutes.
The maximum continuous recording time (up to 15minutes) is displayed on the screen.

About Motion Pictures (AVCHD Lite/Motion JPEG)

Recording format	Effect
 [AVCHD Lite]	This is the data format appropriate to playback on the high definition TV, etc. High definition motion picture can be recorded for a long time.
 [MOTION JPEG]	This is the data format appropriate to playback on the PC, etc. It can be recorded with small picture size, making it convenient when there is not much space left on the memory card or when you want to attach the motion picture to an e-mail on the PC later.

When [AVCHD Lite] is selected

	Item	Quality (bit rate) ^{*1}	Aspect ratio
High quality   Longer time	 1280 × 720 pixels 17 Mbps ^{*2}	16:9	
	 1280 × 720 pixels 13 Mbps ^{*2}		
	 1280 × 720 pixels 9 Mbps ^{*2}		





*1 What is bit rate

This is the volume of data for a definite period of time, and the quality becomes higher when the number gets bigger. This unit is using the "VBR" recording method. "VBR" is an abbreviation of "Variable Bit Rate", and the bit rate (volume of data for definite period of time) is changed automatically depending on the subject to record. Therefore, the recording time is shortened when a subject with fast movement is recorded.



*2 What is Mbps

This is an abbreviation of "Megabit Per Second", and it represents the speed of transmission.



When [MOTION JPEG] is selected

Item	Picture size	fps	Aspect ratio
	1280 × 720 pixels	30	16:9
 ^{*3}	848 × 480 pixels		
	640 × 480 pixels		4:3
	320 × 240 pixels		

*3 This item cannot be set in the Intelligent Auto Mode.

- With the  for [AVCHD Lite] or [MOTION JPEG], high quality motion picture can be enjoyed on the TV by using the HDMI mini cable (optional). For details, see "Playing back on the TV with HDMI socket".
- It cannot be recorded to built-in memory except for the .

Note

- It is recommended to use a card with SD Speed Class^{*1} with "Class 6" or higher when recording motion pictures.
- *1 The SD Speed Class Rating is the speed standard for successive writes.
- When you set the picture quality to ,  or , we recommend using a high-speed card with "10MB/s" or greater displayed on the package.
- Motion picture recorded continuously in [MOTION JPEG] is up to 2 GB. Only the maximum recordable time for 2 GB is displayed on the screen. [AVCHD Lite] can be recorded to the capacity of the card.^{*2}
- *2 The recording may stop even if there is more space left in the card depending on the life of the battery.
- The motion pictures recorded in [AVCHD Lite] can be played back with an AVCHD compatible device. Check the compatibility with the instruction manual of the device. However, some of the compatible devices may play back with lower image or audio qualities, or may not play back. Also, the recording information may not display correctly. In these cases, play back with this unit.
- The motion pictures recorded in [AVCHD Lite] cannot be played back with devices not compatible with AVCHD (such as conventional DVD recorders).
- Motion picture recorded in [AVCHD Lite] does not comply with the "DCF/Exif", so some information, will not display while playback.
- A sound might be muffled or warped when there is water on the microphone or the speaker. Wipe the residue after letting the water drip out from the microphone and speaker by tipping it down, and use it after letting it dry for a while.

(Important) About the waterproof/dustproof and anti-shock performance of the camera

- Please observe the following precautions, and avoid using this camera in any situation where the camera is subject to high water pressure. This camera's waterproof/dustproof rating complies with the "IPX8" and "IP5X" ratings. Provided the care and maintenance guidelines described in this document are strictly followed, this camera can operate underwater, to a depth not exceeding 3 m (10 feet) for a time not exceeding 60 minutes.*¹ This camera also complies with "MIL-STD 810F (Method 516.5-Shock)."^{*2} The camera has cleared a drop test from a height of 1.5 m (5 feet) onto 5 cm (0.17 feet) thick plywood. In most cases this camera should not sustain any damage if dropped from a height not exceeding 1.5 m (5 feet).

• Supplied accessories are not waterproof.

*¹ This means that the camera can be used underwater for specified time in specified pressure in accordance with the handling method established by Panasonic. This does not guarantee no destruction, no malfunction, or waterproofing in all conditions.

*² This does not guarantee no destruction, no malfunction, or waterproofing in all conditions.

Observe the following precautions and avoid using under water pressure exceeding the guaranteed performance, and in an environment with excessive dust or sand. Waterproofing is not guaranteed if the unit is subject to an impact as a result of being hit or dropped etc.

When an impact is applied to the camera, it is recommended to consult Panasonic's Service Center and perform a checkup (subject to a fee) to see if the waterproofing has been retained properly.

Any malfunction caused by customer misuse, or mishandling will not be covered by the warranty.

■ Handling of the camera

- Do not leave the camera under low temperature in the cold climate, or where it has high temperature above 40 °C (104 °F) (especially where strong sunlight is shining, inside a car under the sun, close to a heater, in the ship, beach, etc.) for long period of time. (Waterproof performance will degrade)
- Do not open or close the card/battery door or terminal cover close to the water at the sea, lake, river or with wet hands.
- Waterproof function of the camera is for sea water and fresh water only.

■ Confirm that there is no foreign object

- In the areas adjacent to location (B), please be sure that no droplets of water are present before opening the battery door.
- Before closing the card/battery door or terminal cover, confirm that there are no foreign objects (hair, lint, sand, dust, fluid, etc.) on the part ((B) and (C)) colored black in the figure. When the camera is used underwater with foreign objects clamped on the card/battery door or the terminal cover, water may leak in, causing a malfunction.
- Wipe it off with a dry soft cloth if there is any liquid.
- If there is any foreign object, remove it with attached brush.
- If there is any crack or deformation in the area colored black in the figure, contact Panasonic's Service Center.
- Keep the Brush out of reach of children to prevent swallowing.

- (A) Card/Battery door
- (B) Rubber seal
- (C) Area where rubber seal sits
- (D) Terminal cover
- (E) Hair and lint
- (F) Sand and dust
- (G) Crack and deformation
- (H) Fluid
- (I) Brush (supplied)

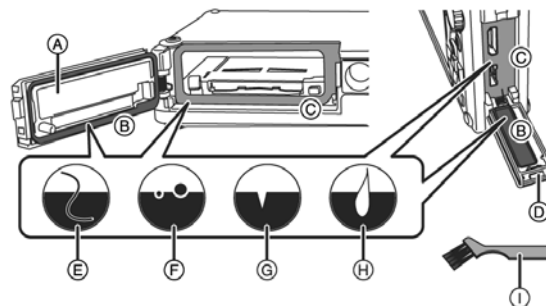

■ Securely close the SD card/battery door and terminal cover

- (A) Red part

• To prevent water leakage please check very carefully that no foreign object such as sand, hair, dust or fluid is present anywhere within the area of the door seal and door. Close the door by pressing it firmly until it clicks. Confirm that the "red" area on the lock tab is not visible.

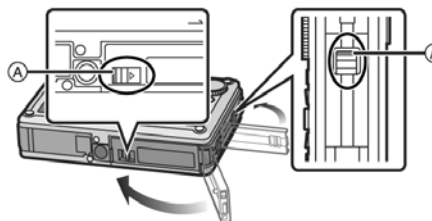

■ Using the camera underwater

- This camera can be used under water to a depth not exceeding 3 m (10 feet), where the water temperature is between 0 °C to 40 °C (32 °F to 104 °F) and not longer than 60 minutes continuously.
- If there is water or dirt on the camera, use it after wiping it off with a dry soft cloth and dried in a well ventilated area.
- Do not open or close the card/battery door or terminal cover.
- Do not apply shock to the camera underwater. (Waterproof performance may not be maintained, and there is a chance of water leak)
- Do not dive into the water holding the camera. Do not use the camera at the location where the water will splash strongly, such as rapid flow or waterfall. (Strong water pressure may be applied, and it may cause malfunction)
- The camera will sink in the water. Take care not to drop the camera and lose it underwater by securely placing the hand strap around your wrist or similar measure.
- Do not use in water that exceeds 40 °C (104 °F) such as in baths, hot tubs, spas and hot springs.
- When the camera is splashed with detergent, soap, hot spring, bath additive, sun oil, sun screen, chemical, etc., wipe it off immediately.
- Card and battery are not waterproof. Do not handle with a wet hand. Also, do not insert wet card or battery into the camera.

■ Caring of the camera after using it underwater

- After all underwater use, dry the camera thoroughly, as quickly as possible using a lint free cloth. This must be done within 60 minutes of use, or the waterproof seals may be damaged.
- If the camera was used in salt water the camera must be thoroughly rinsed and cleansed as quickly as possible. It's recommended that it is first rinsed with fresh water, then submersed in fresh water in a shallow container for about 10 minutes. When the camera is removed, thoroughly dry it.
- Droplets of water may collect in the area around the battery door. Before opening the door make sure this area is water-free.
- This camera has a water drain that allows water that has accumulated under the plastic trim to drain. This may continue for up to 10 minutes, even after the camera is dried. You can place the camera in a vertical position on a dry cloth during this time.
- If the zoom lever or mode dial does not move smoothly, it may be caused by the adhesion of foreign objects. It may cause malfunctions, such as locking up, so wash off any foreign objects on the zoom lever or mode dial by shaking the camera in fresh water. Confirm that the zoom lever and mode dial moves smoothly after cleaning.
- After soaking or washing the unit, wipe off water drops with a dry soft cloth and dry the unit in an area of shade with a draft.
- This unit incorporates drain design, draining water in gaps in the power button and zoom lever etc. As a result of this, bubbles may come out when you soak the unit in water, but it is not a malfunction. Make sure that water is completely drained from the unit after soaking in water by standing the unit on a dry cloth for a while.
- Do not dry the camera with hot air from dryer or similar. Waterproof performance will deteriorate due to deformation.
- Do not use chemicals, such as benzine, thinner, or alcohol, soap, detergents.



■ Replacing the waterproof seal

- The integrity of the waterproof seals may decrease after about 1 year, with use and age. To avoid permanently damaging the camera the seals should be replaced once each year. Please contact Panasonic's Service Center for related costs and other information.

5 Location of Controls and Components

Names of the Components

- 1 Flash
- 2 Self-timer indicator
- 3 Lens
- 4 LCD monitor
- 5 Status indicator
- 6 Playback button
- 7 [MENU/SET] button
- 8 [DISPLAY] button
- 9 [Q.MENU] /Delete button
- 10 Motion picture button
- 11 Mode dial

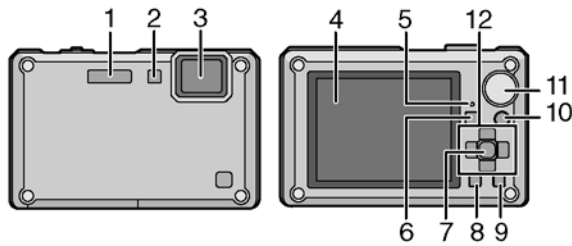

12 Cursor buttons

- Ⓐ: ▲/Exposure compensation/
Auto bracket/White balance
fine adjustment
- Ⓑ: ▼/Macro mode
AF Tracking
- Ⓒ: ◀/Self-timer button
- Ⓓ: ▶/Flash setting button

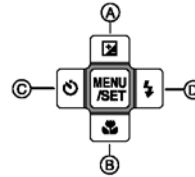

In these operating instructions, the cursor buttons are described as shown in the figure below or described with ▲/▼/◀/▶.
e.g.: When you press the ▼ (down) button



- 13 Shutter button
- 14 Camera ON/OFF button
- 15 Zoom lever
- 16 Microphone
- 17 Speaker
- 18 Hand strap eyelet
- 19 [HDMI] socket
- 20 [AV/DIGITAL/MULTI] socket
- When using an AC adaptor, ensure that the Panasonic multi conversion adaptor (DMW-MCA1; optional) and AC adaptor (DMW-AC5; optional) are used.
- 21 Tripod receptacle
- When you use a tripod, make sure the tripod is stable when the camera is attached to it.
- 22 Card/Battery door
- 23 Release lever

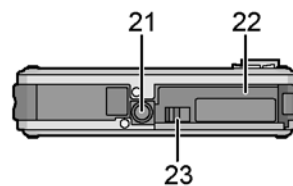
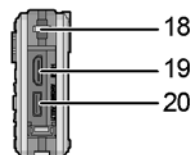
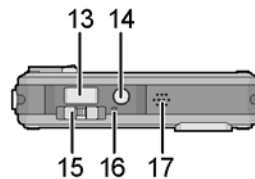

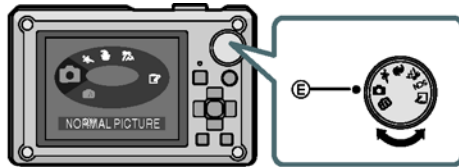

List of [REC] modes

	Intelligent auto mode
The subjects are recorded using settings automatically selected by the camera.	
	Normal picture mode
The subjects are recorded using your own settings.	
	Sports mode
Use this mode to take pictures of sporting events, etc.	
c It will be a normal motion picture recording during the motion picture recording.	
	Snow mode
This allows you to take pictures that show the snow as white as possible at a ski resort or a snow-covered mountain.	
	Beach & Surf mode
This mode is optimal for taking pictures up to 3 m (10 feet) underwater and at the beach.	
	SCN Scene mode
This allows you to take pictures that match the scene being recorded.	
	Clipboard mode
Record as a memo.	
* Motion picture cannot be taken in Clipboard mode.	

About the Battery

- This unit has a function that can distinguish useable batteries. Exclusive batteries are supported by this function. (Conventional batteries not supported by this function cannot be used.)

It has been found that counterfeit battery packs which look very similar to the genuine product are made available to purchase in some markets. Some of these battery packs are not adequately protected with internal protection to meet the requirements of appropriate safety standards. There is a possibility that these battery packs may lead to fire or explosion. Please be advised that we are not liable for any accident or failure occurring as a result of use of a counterfeit battery pack. To ensure that safe products are used we would recommend that a genuine Panasonic battery pack is used.

6 Service Mode

6.1. Error Code Memory Function

1. General description

This unit is equipped with history of error code memory function, and can be memorized 16 error codes in sequence from the latest. When the error is occurred more than 16, the oldest error is overwritten in sequence.

The error code is not memorized when the power supply is shut down forcibly (i.e., when the unit is powered on by the battery, the battery is pulled out) The error code is memorized to FLASH ROM when the unit has just before powered off.

2. How to display

The error code can be displayed by ordering the following procedure:

• Preparation:

1. Attach the Battery or AC Adaptor with a DC coupler to the unit.

NOTE:

*Since this unit has built-in memory, it can be performed without inserting SD memory card.

*Set the mode dial other than "CLIPBOARD (memo)" mode (such as normal picture / iA / Sports / Snow / SCN) to display the error code.

• Step 1. The temporary cancellation of "INITIAL SETTINGS":

While keep pressing "UP of Cursor button" and DISPLAY button simultaneously, turn the Power on.

• Step 2. Execute the error code display mode:

Press the "LEFT of Cursor button", MENU/SET button and DISPLAY button simultaneously.

The display is changed as shown below when the above buttons are pressed simultaneously.

Normal display → Error code display → Operation history display → Normal display →

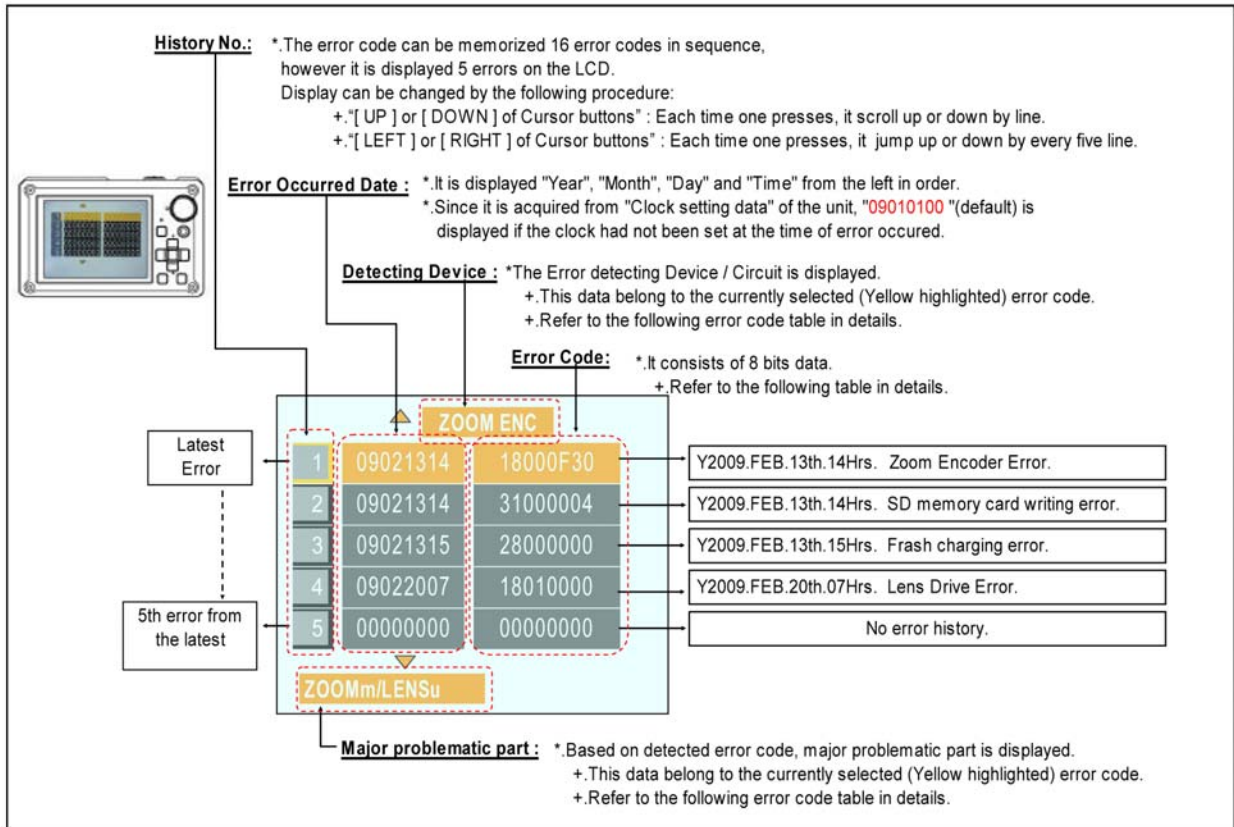

3. Error Code List

The error code consists of 8 bits data and it shows the following information.

Attribute	Main item	Sub item	Error code		Contents (Upper)	Error Indication		
			High 4bits	Low 4 bits	Check point (Lower)	Detecting device	Part/Circuit	
LENS	Lens drive	OIS	18*0	1000	PSD (X) error. Hall element (X axis) position detect error in OIS unit. OIS Unit	OIS X	LENSu NG	
				2000	PSD (Y) error. Hall element (Y axis) position detect error in OIS unit. OIS Unit	OIS Y		
			3000	GYRO (X) error. Gyro (IC7101) detect error on Main P.C.B.. IC7101 (Gyro element) or IC6001 (VENUS HD)	JYRO X	JYRO NG		
				4000	GYRO (Y) error. Gyro (IC7101) detect error on Main P.C.B.. IC7101 (Gyro element) or IC6001 (VENUS HD)		JYRO Y	
			5000	MREF error (Reference voltage error). IC9101 (LENS drive) or IC6001 (VENUS HD)	OIS REF	LENSSd/DSP NG		
				6000	Drive voltage (X) error. LENS Unit, LENS flex breaks, IC6001(VENUS HD) AD value error, etc.		OISX REF	LENSu/LENS FPC
			7000	Drive voltage (Y) error. LENS Unit, LENS flex breaks, IC6001(VENUS HD) AD value error, etc.	OISY REF			
				Zoom	0?10	Collapsible barrel Low detect error (Collapsible barrel encoder always detects Low.) Mechanical lock, FP9005-(26) signal line or IC6001 (VENUS HD)	ZOOM L	ZOOMm/ LENSu
			0?20			Collapsible barrel High detect error (Collapsible barrel encoder always detects High.) Mechanical lock, FP9005-(26) signal line or IC6001 (VENUS HD)	ZOOM H	
			0?60			The zoom position jump is detected due to the impact (i.e. drop.) to the camera occurs. Lens unit	(No indication)	(No indication)
			Focus	0?01	HP High detect error (Focus encoder always detects High, and not becomes Low) Mechanical lock, FP9005-(26) signal line or IC6001 (VENUS HD)	FOCUS L	LENS FPC/ DSP	
					0?02	HP Low detect error (Focus encoder always detects Low, and not becomes High) Mechanical lock, FP9005-(26) signal line or IC6001 (VENUS HD)		FOCUS H
			Lens	18*1	0000	Power ON time out error. Lens drive system	LENS DRV	LENSu
					18*2	0000		
		Adj.History	OIS	19*0	2000	OIS adj. Yaw direction amplitude error (small)	OIS ADJ	OIS ADJ
					3000	OIS adj. Pitch direction amplitude error (small)		
					4000	OIS adj. Yaw direction amplitude error (large)		
					5000	OIS adj. Pitch direction amplitude error (large)		
					6000	OIS adj. MREF error		
					7000	OIS adj. time out error		
					8000	OIS adj. Yaw direction off set error		
					9000	OIS adj. Pitch direction off set error		
					A000	OIS adj. Yaw direction gain error		
					B000	OIS adj. Pitch direction gain error		
					C000	OIS adj. Yaw direction position sensor error		
					D000	OIS adj. Pitch direction position sensor error		
E000	OIS adj. other error							
HARD	VENUS A/ D	Flash	28*0	0000	Flash charging error. IC6001-(AA17) signal line or Flash charging circuit	STRB CHG	STRB PCB/ FPC	

Attribute	Main item	Sub item	Error code		Contents (Upper)	Error Indication		
			High 4bits	Low 4 bits	Check point (Lower)	Detecting device	Part/Circuit	
	FLASH ROM (EEPROM Area)	FLASH ROM (EEPROM Area)	2B*0	0001	EEPROM read error	FROM RE	FROM	
				0003				
				0004	IC6002 (FLASH ROM)			
				0002	EEPROM write error IC6002 (FLASH ROM)	FROM WR	FROM	
				0005	Firmware version up error Replace the firmware file in the SD memory card.	(No indication)	(No indication)	
				0008	SDRAM error			
		0009	SDRAM Mounting defective					
	SYSTEM	RTC	2C*0	0001	SYSTEM IC initialize failure error Communication between IC6001 (VENUS HD) and IC9101 (SYSTEM)	SYS INIT	MAIN PCB	
SOFT	CPU	Reset	30*0	0001 0007	NMI reset Non Mask-able Interrupt (30000001-30000007 are caused by factors)	NMI RST	MAIN PCB	
	Card	Card	31*0	0001	Card logic error SD memory card data line or IC6001 (VENUS HD)	SD CARD	SD CARD/ DSP	
				0002	Card physical error SD memory card data line or IC6001 (VENUS HD)			
				0004	Write error SD memory card data line or IC6001 (VENUS HD)			SD WRITE
			39*0	0005	Format error	INMEMORY	FROM	
	CPU, ASIC hard	Stop	38*0	0001	Camera task finish process time out. Communication between Lens system and IC6001 (VENUS HD)	LENS COM	LENSu/DSP	
					0002			Camera task invalid code error. IC6001 (VENUS HD)
					0100			File time out error in recording motion image IC6001 (VENUS HD)
				0200	File data cue send error in recording motion image IC6001 (VENUS HD)			
				0300	Single or burst recording brake time out.			
		Memory area	3A*0	0008	USB work area partitioning failure USB dynamic memory securing failure when connecting	(No indication)	(No indication)	
	Operation	Power on	3B*0	0000	FLASHROM processing early period of camera during movement.	INIT	(No indication)	
	Zoom	Zoom	3C*0	0000	Imperfect zoom lens processing Zoom lens	ZOOM	ZOOMm/ LENSu	
					35*0			0000
			35*1	0000	Though record preprocessing is necessary, it is not called.	(No indication)	(No indication)	
35*2			0000	Though record preprocessing is necessary, it is not completed.				

1) About "*" indication:

The third digit from the left is different as follows.

In case of 0 (example: 18 0 01000)

When the third digit from the left shows "0", this error occurred under the condition of INITIAL SETTINGS has been completed.

It means that this error is occurred basically at user side.

In case of 8 (example: 18 8 01000)

When the third digit from the left shows "8", this error occurred under the condition of INITIAL SETTINGS has been released.

(Example; Factory assembling-line before unit shipment, Service mode etc.)

It means that this error is occurred at service side.

2) About "?" indication: ("18*0 0?01" to "18*0 0?50"):

The third digit from the right shows one of the hexadecimal ("0" to "F") character.

4.How to returned to Normal Display:

Turn the power off and on, to exit from Error code display mode.

NOTE:

The error code can not be initialized.

6.2. ICS (Indication of additional Camera Settings when picture was taken) function

1. General description

This unit is equipped with ICS (ICS : Indication of additional Camera Settings when picture was taken) function by playing back the concerned picture on the LCD display.

(This function is achieved by utilizing "maker note" data stored in Exif data area of recorded picture file.)

To proceed failure diagnosis, use this ICS function together with "displaying the recorded picture with picture information" function.

NOTE:

- *.The ICS function operates with a picture which is only taken with the same model. (It may not be displayed when the picture was taken with other model.)
- *.Since Exif data is not available after the picture is edited by PC, the ICS function may not be activated.

2. How to display

The ICS data is displayed by ordering the following procedure:

• Preparation:

- 1.Attach the Battery or AC Adaptor with a DC coupler to the unit.

NOTE:

- *Set the mode dial other than "CLIPBOARD (memo) "mode (such as normal picture / iA / Sports / Snow / SCN) to display the ICS data.

• Step 1. The temporary cancellation of "INITIAL SETTINGS":

While keep pressing "UP of Cursor button" and DISPLAY button simultaneously, turn the Power on.

• Step 2. Execute the ICS display mode:

Press the PLAYBACK button.

Select the concerned picture by pressing the "LEFT and RIGHT of Cursor button".

Press the "LEFT of Cursor button", MENU/SET button and DISPLAY button simultaneously.

Press the DISPLAY button, 3 times.

The display condition is changed as shown below when the DISPLAY button is pressed.

Code display → Code + Picture display (1) → Code + Picture display (2) → ICS display →

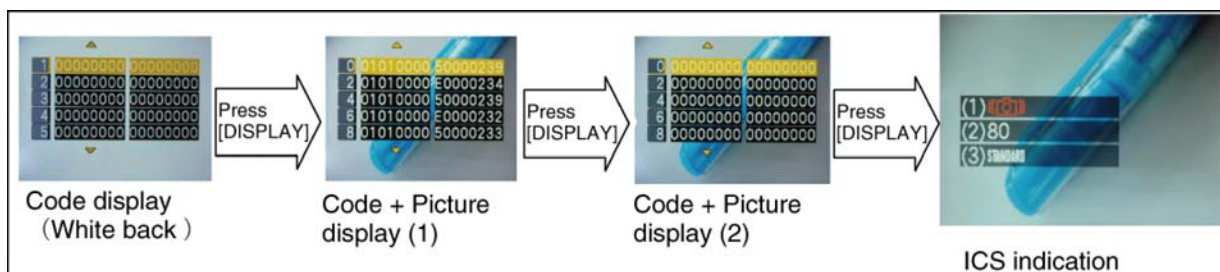

3. How to read

(1). Jitter alert was displayed or not:

This part shows that the "Jitter alert" mark was displayed or not when the picture has just before been taken.

- +With "Jitter alert" mark : The "Jitter alert" mark was displayed.
- +Without "Jitter alert" mark : The "Jitter alert" mark was not displayed.

[About "Jitter alert" mark]

Due to lacking the enough light amount etc, shooting condition prone to make a "hand jitter", the "Jitter alert" mark is displayed.

[Reference Guide]

(Applicable settings: Normal picture mode, ISO100, WIDE edge, Flash OFF)

- +The "Jitter alert" mark is displayed when the shutter speed is 1/15th and below.

Normal playback screen
(Recorded picture with information)



*In playback mode, the picture information is displayed when pressing the [DISPLAY] button. (It can be confirmed at user as well.)

*Use this indication together with ICS function.

(2). ISO Sensitivity Setting condition:

This part shows that the "ISO Sensitivity" setting condition when the picture had been taken.

(Note: The [i ISO] is displayed when the "Intelligent ISO" was selected.)

For instance, when the recorded picture information shows [ISO80], it can be confirmed the ISO setting condition ; [AUTO], [INTELLIGENT ISO] or [ISO 80](Fixed: set by user).

[Point for Confirmation]

- *The symptom is "Picture with "hand jitter". Subject is not clearly stopped." in darker scene, does the picture was taken with lower ISO setting mode?
- *The symptom is "Noisy picture. Rough picture image" in brighter scene, does the picture was taken with higher ISO setting mode?

(3). Color mode Setting condition:

This part shows that the "Color mode" setting condition when the picture had been taken.

[Point for Confirmation]

- *The symptom is "Color is strange. The picture is bluish (Yellowish)", does the picture was taken with [SEPIA] / [COOL] / [WARM] settings?

NOTE: As for the symptom related with the color, confirm the picture information which is displayed in normal playback screen as well.

(In normal playback screen, the setting condition of "White balance" and "WB Adjustment" can be confirmed.)

[ICS display
(Sample)]

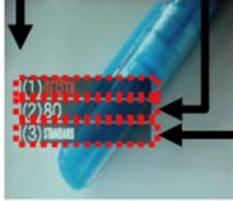

- (1). Jitter alert mark: [Indicated]
- (2). ISO sens. setting : ISO80 (Fixed)
- (3). Color mode setting: Standard

[Refer ence Guide : Settings "When taking

<ISO SENSITIVITY>

*This allows the sensitivity to light (ISO sensitivity) to be set. Setting to a higher figure enables pictures to be taken even in dark places without the resulting pictures coming out dark.

*In this unit, it can be set one of the [AUTO], [80], [100], [200], [400], [800] and [1600] in "Normal shooting" mode.

(The ISO sensitivity setting is not available when the [INTELLIGENT ISO] is being used.)

*When setting to [AUTO], the ISO sensitivity is automatically adjusted to a maximum of [ISO400] according to the brightness. (It can be adjusted to a maximum of [ISO1000] when using the flash.)

*To avoid picture noise, we recommend that you either reduce the ISO sensitivity level or set [COLOR MODE] to [NATURAL], and then take pictures.

ISO sensitivity	80	← →	1600
Recording location (recommended)	When it is light (outdoors)		When it is dark
Shutter speed	Slow		Fast
Noise	Less		Increased

<COLOR MODE>

*Using these modes, the pictures can be made sharper or softer, the colors of the pictures can be turned into sepia colors or other color effects can be achieved.

*In this unit, it can be set one of the following effects in "Normal shooting" mode.

[STANDARD] : This is the standard setting.	[B/W] : The picture becomes black and white.
[NATURAL] : The picture becomes softer.	[SEPIA] : The picture becomes sepia.
[VIVID] : The picture becomes sharper.	[COOL] : The picture becomes bluish.
	[WARM] : The picture becomes reddish.

NOTE: You cannot set [NATURAL], [VIVID], [COOL] or [WARM] in Intelligent auto mode.

4. How to exit :

Simply, turn the power off. (Since ICS function is executed under the condition of temporary cancellation of "INITIAL SETTINGS", it wake up with normal condition when turn off the power.)

7 Troubleshooting Guide

7.1. Service and Check Procedures

7.1.1. Servicing flow

- The following is the servicing procedure including assembly/disassembly process.
- As for the air-leak test, refer to "7.2. Air-leak Test".

<NOTE>

Air-leak test (inspection) before taking service measure:

- When the first inspection, do not perform cleaning (removal of foreign objects caught etc.) of the waterproof packing parts (battery door and Jack door) from the viewpoint of the cause investigation at NG of test (inspection) result.
- When the test (inspection) result was NG, perform test again after cleaning of waterproof packing parts.

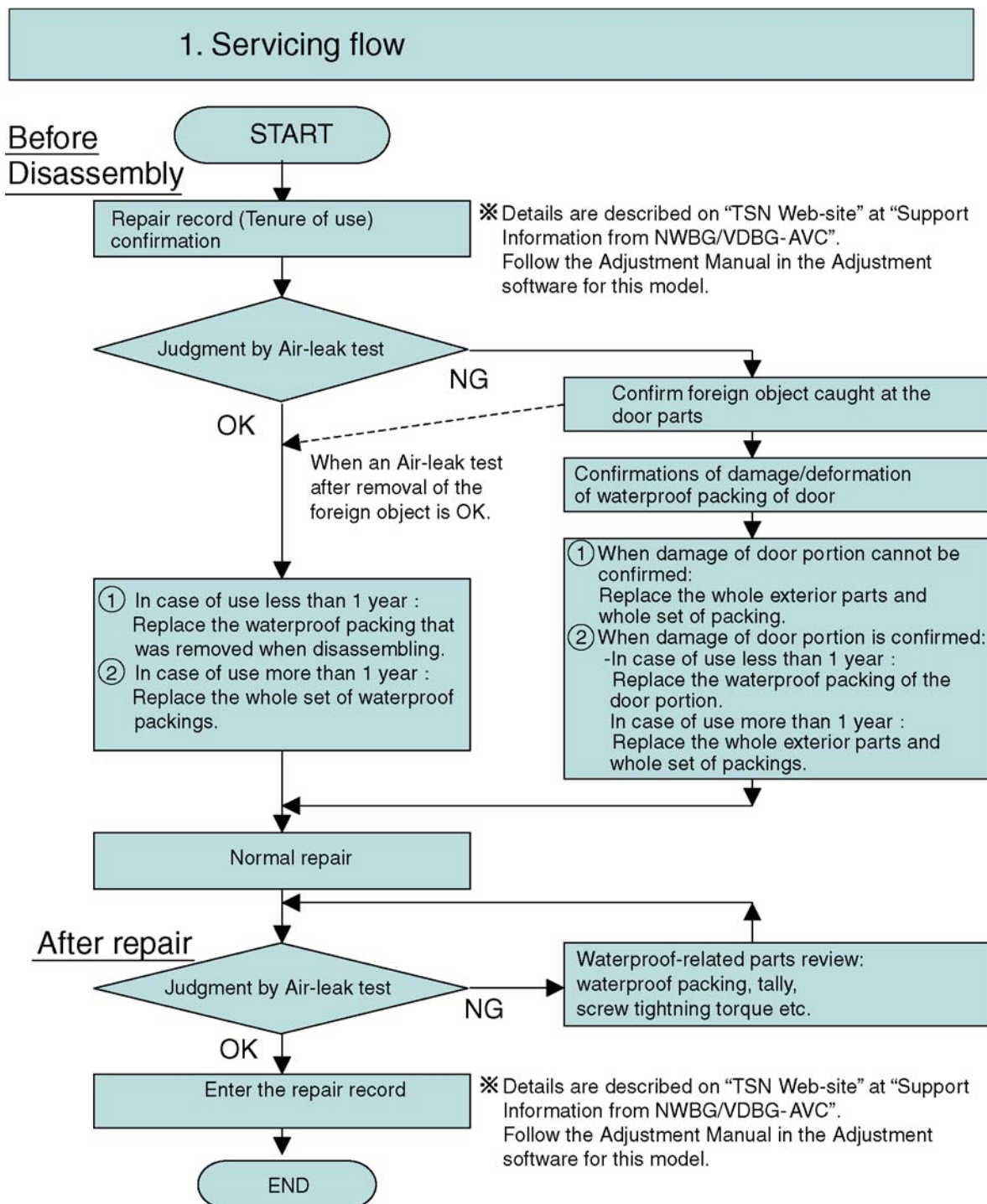

7.1.2. Periodical maintenance (Packing replacement) flow

- The integrity of the waterproof packings may decrease about 1 year, with use and age.
(We recommend end-users to replace the waterproof packing at least once each year described in the operating instructions.)
- Please use waterproof packing kit (Part No.: VUMG1863). (7 types, 8 packings in total are included)
- Do not touch the waterproof packings directly by the hand.
- Do not perform cleaning of waterproof packings by the solvent of alcohol etc. or by blowing air.
- Take care not to put any foreign objects (garbage and dust).
- As for the air-leak test, refer to "7.2. Air-leak Test".

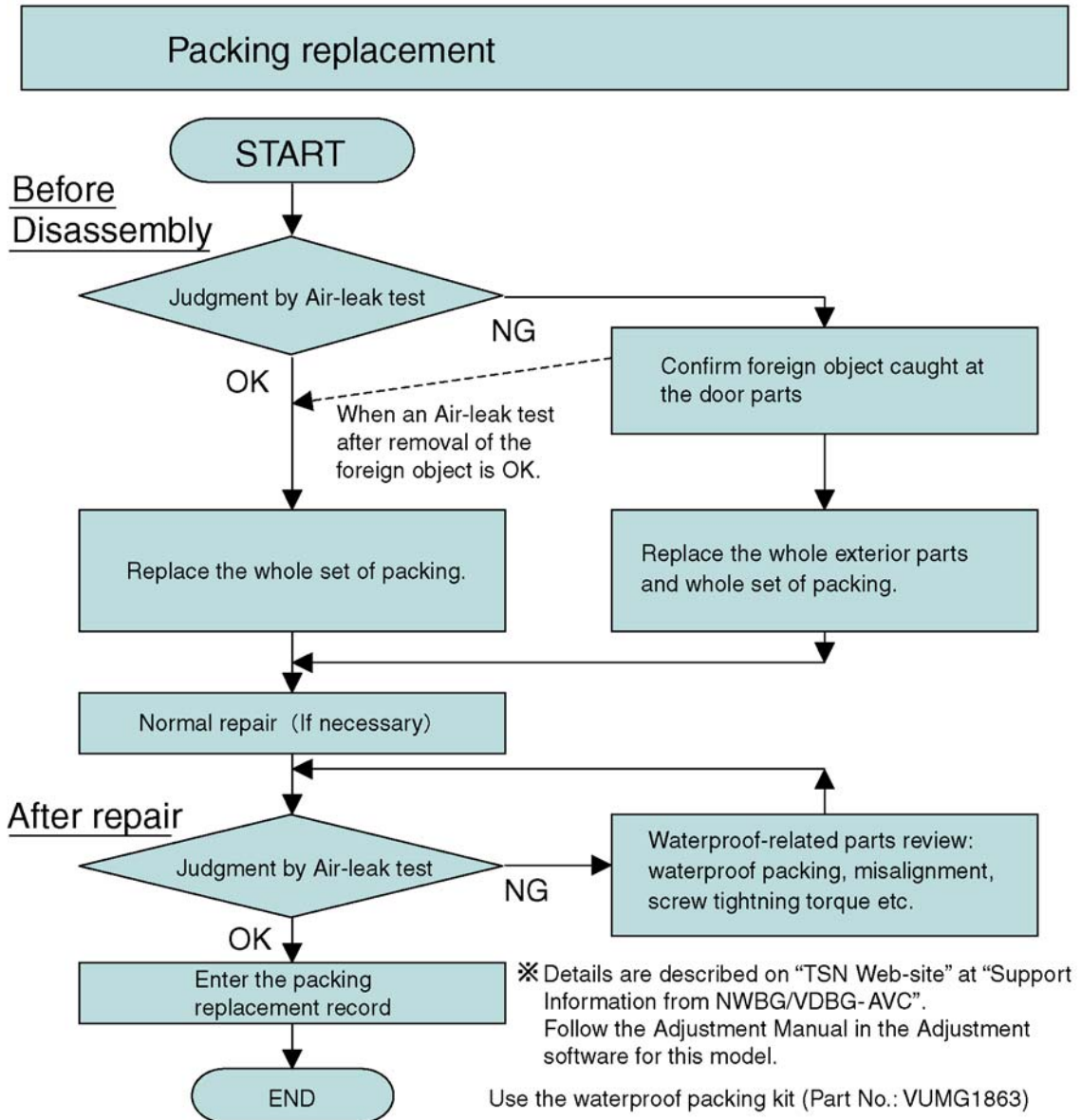

Replacing the waterproof packing

- The location of waterproof packing are shown at right. (7 types, 8 packings in total)
- Waterproof packings are supplied as Waterproof packing kit (Part No.: VUMG1863).

<Note for replacement>

- Do not touch the waterproof packings directly by the hand.
- Do not perform cleaning of waterproof packings by the solvent of alcohol etc. or by blowing air.
- Take care not to put any foreign objects (garbage and dust).
- Use the silicon chips (Prt No.: RFKZ0478) when replacing the Case O-ring.
- When replacing the mode dial O-ring, wipe the grease attached to the product first, then apply the grease (Part No.: RFKZ0463).

From Ref No. "P-1" to "P-8" are supplied as a "waterproof packing kit" (Part No. VUMG1863)

■ Mode Dial O-ring :
Wipe the grease attached to the product, and then apply the grease (Part No.: RFKZ0463).

■ Case O-ring :
When replacing Case O-ring, use Silicon chips (Part No.: RFKZ0478)

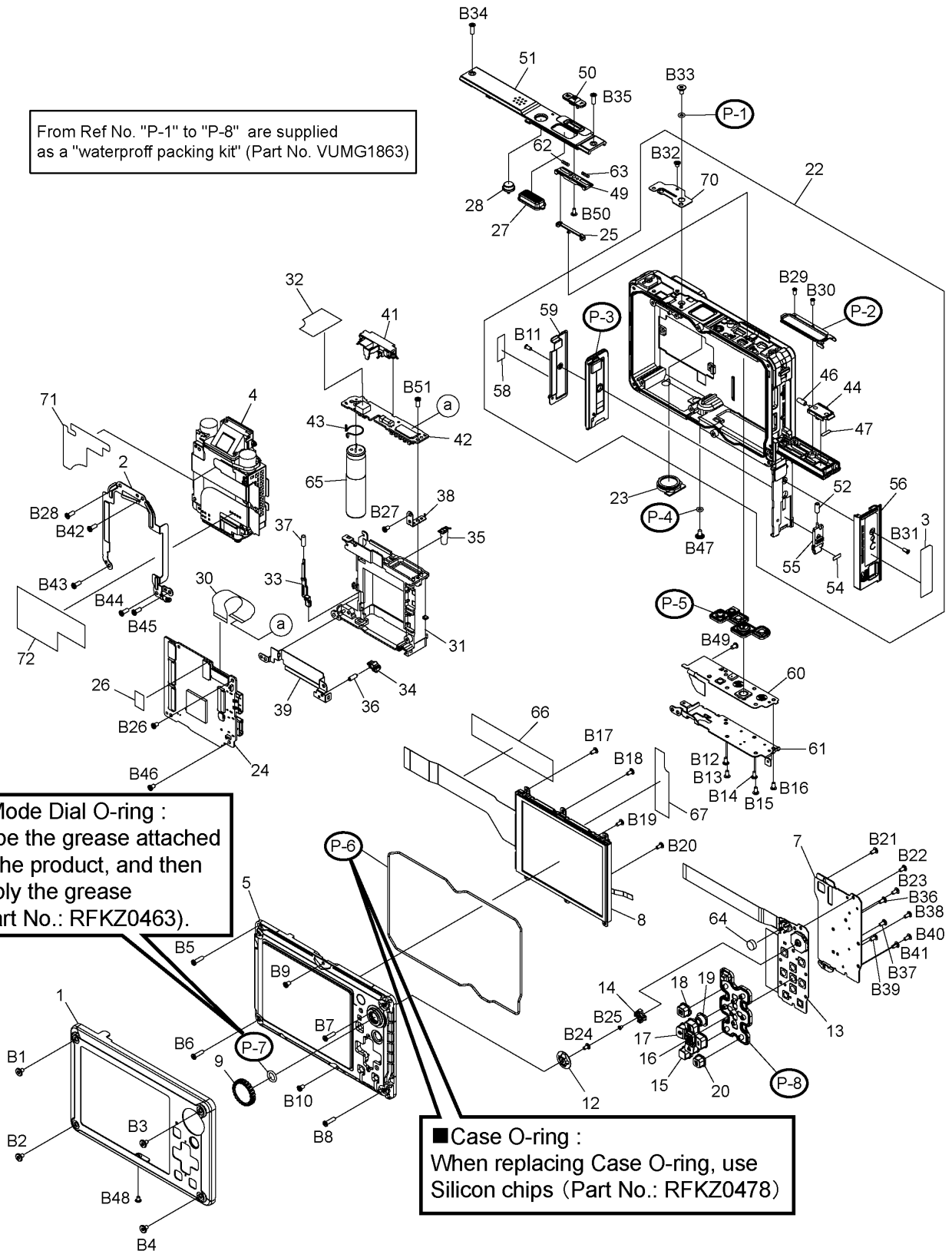

7.2. Air-leak Test

Due to the characteristics of this product, perform the air-leak test using Air-leak tester (Part No.: RFKZ0528) before/after servicing including assembly or disassembly process.

* The air-leak test before servicing is necessary to be performed to check whether the malfunction occurred due to air-leak or not.

1. Preparation

- 1). By referring to "9.3. Assembly/Disassembly procedures", remove the rear aluminium case and top ornament.
- 2) Confirm that there is no foreign objects at the jack door and battery door, and they are firmly closed.



- 3). Attaching the masking sheet

*Attach the masking sheet on the microphone part.

(Procedure)

1. Remove 1 piece of the masking sheet (RFKZ0540) from the sheet card. (5 pieces/sheet)

* Make sure to hold the "stick" part and do not touch the attaching part.

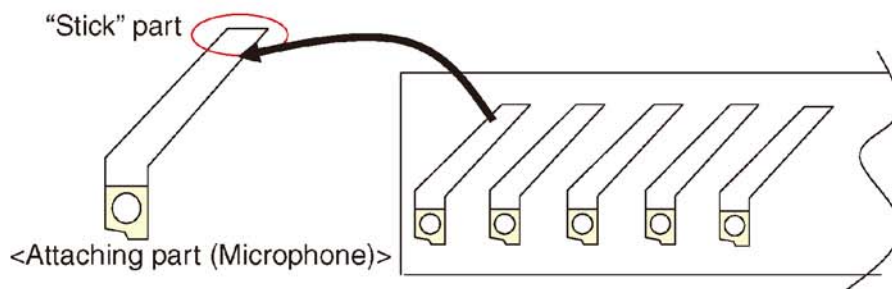

2. Put the adhesive side of masking sheet onto the microphone part as shown at left and compress firmly and evenly using a handle of tweezers, etc.

Confirm the black and round pattern is formed at the circumference of the microphone part.

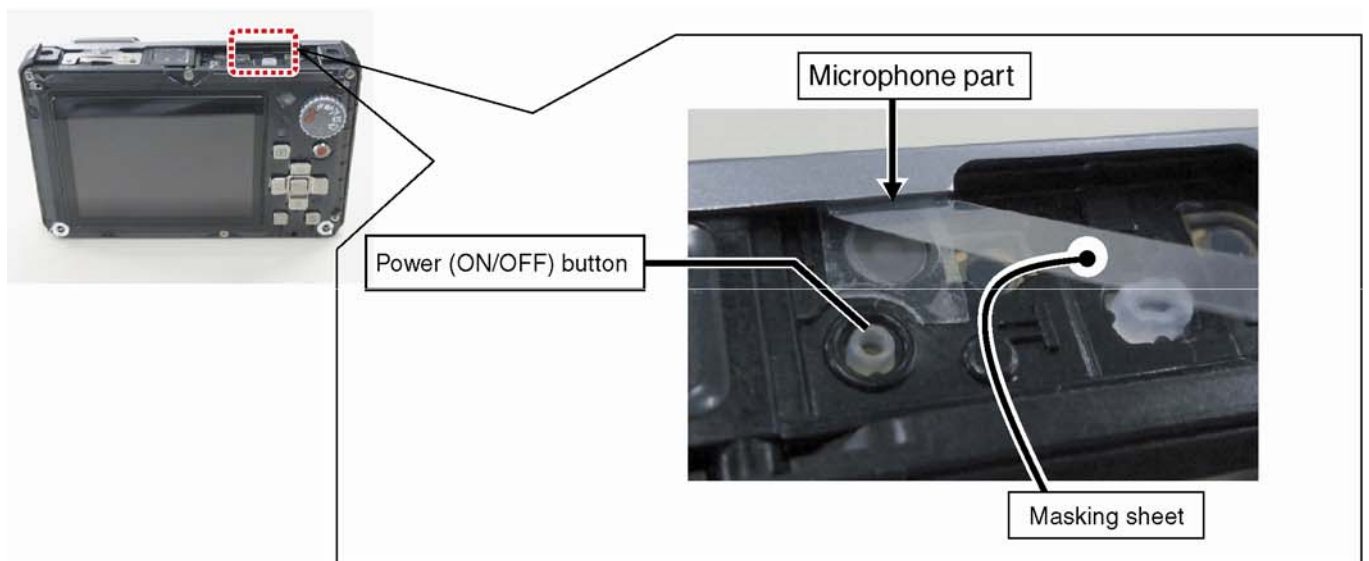

7.3. Air-leak Test (Inspection)

* Perform the air-leak test according to the following procedure.

<Note>

For more details of handling the air-leak tester, refer to the operating instructions.

[Preparation]

1. Put the camera with the rear case facing up.
2. Set the following measurement pressure value for the air-leak tester (RFKZ0528)

Measurement pressure value: -33 kPa

*As for the setting procedure, refer to the operating instructions.

3. Set the vacuum pad of air-leak tester vertically on the test hole (white part).

<Note>

• Keep this setting securely until the measurement is complete.

If the packing is misaligned from the test hole or removed during the test process, restart from this step.

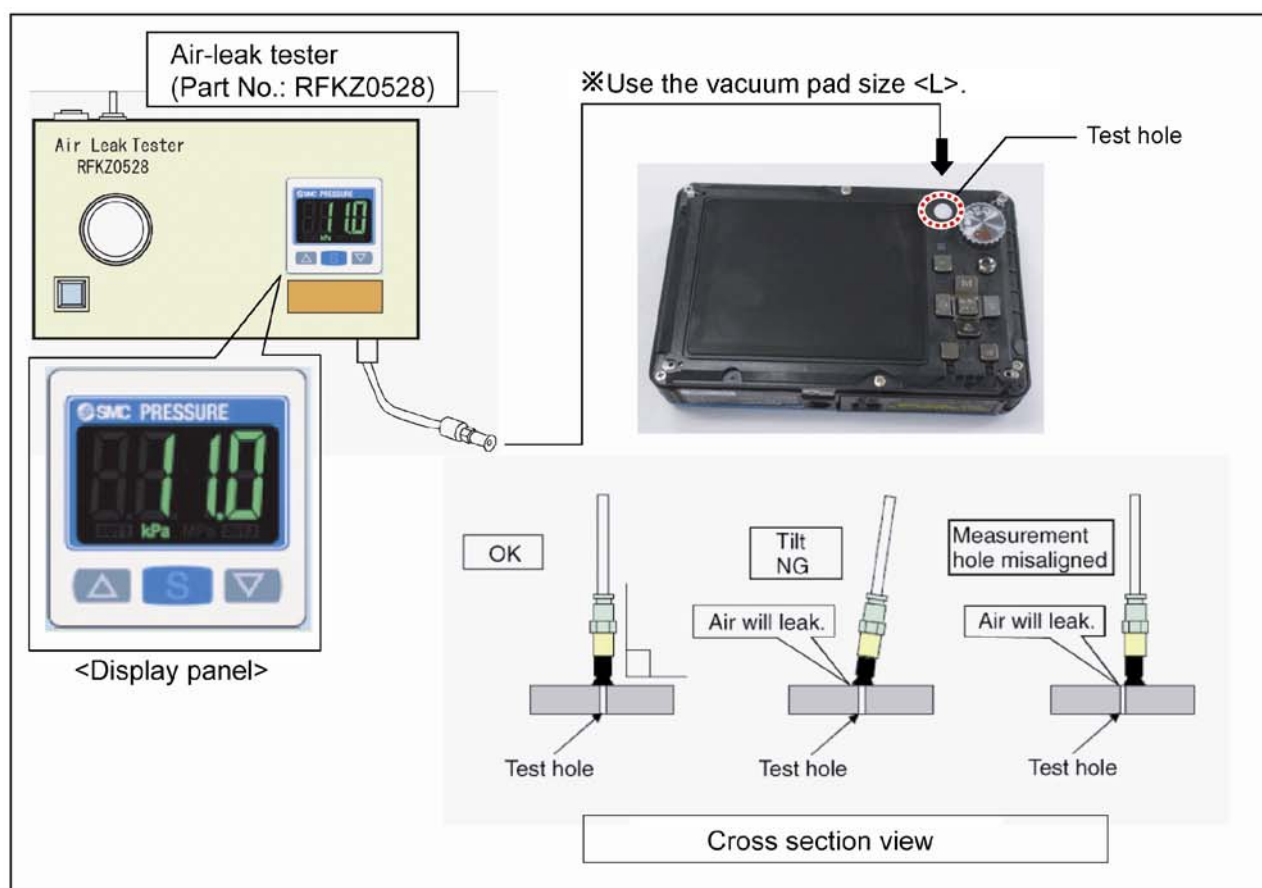

[Exhaust Air]

4. Operate the measurement switch of the air-leak tester to exhaust air inside the product with the specified exhaust time (① to ⑤).

[Specification]: ①10 sec.(Exhaust air) → ② 5 sec.(Pause) → ③10 sec.(Exhaust air) → ④ 5 sec.(Pause) → ⑤ 10 sec. (Exhaust air)

- ① Press the measurement switch to exhaust air for 10 seconds. (The vacuum pump activates.)
- ② Press the measurement switch to pause for 5 seconds.
- ③ Press the measurement switch to exhaust air for 10 seconds. (The vacuum pump activates.)
- ④ Press the measurement switch to pause for 5 seconds.
- ⑤ Press the measurement switch to exhaust air for 10 seconds. (The vacuum pump activates.)

[Standby]

5. Press the measurement switch to record the pressure value on the display panel after a lapse of 10 seconds.

[Measurement]

6. Confirm that the pressure value fluctuations in measurement process are within the test specifications.

The air-leak test is now completed.

Peel off Masking sheet (Part No.: RFKZ0540) attached to microphone part.

-If you have replaced the packing parts, make sure to take notes of "Packing replacement record".

*For more details, follow "Adjustment manual" in the Adjustment software for this model described on "TSN Web-site" at "Support Information from NWBG/VDBG-PAVC".

<Reference information>

Pressure meter value and test flow (time)

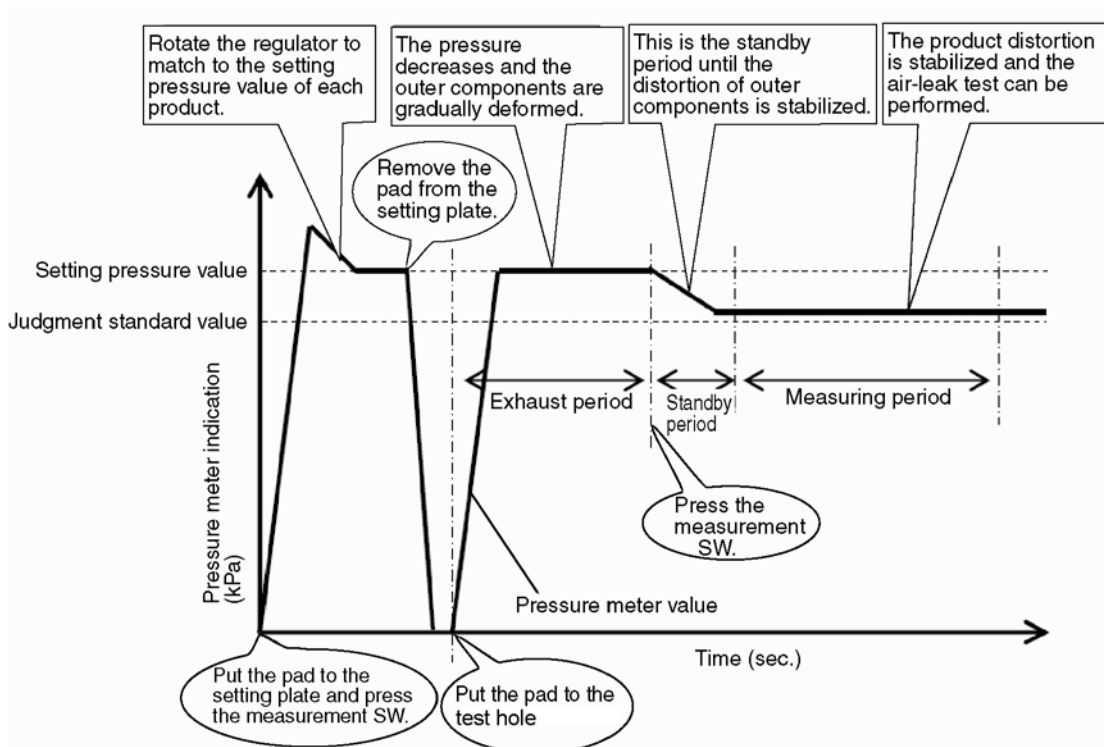

■ Measuring condition (For DMC-FT1 and DMC-TS1)











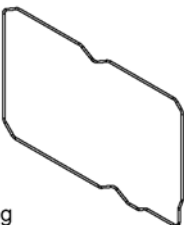

*Use the vacuum pad size <L>.

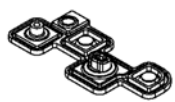
Item	Specifications	Remarks
Setting pressure value	-33kPa	10% increase of the unit performance 3m (-30kPa)
Setting standard value	-30kPa	
Exhaust period	1) 10 sec.: Exhaust air 2) 5 sec.: Pause 3) 10 sec.: Exhaust air 4) 5 sec.: Pause 5) 10 sec.: Exhaust air	
Standby period	10 sec.	
Measuring period (Period)	30 sec.	
Test Specifications	±0.2kPa	Pressure variation during the measuring period

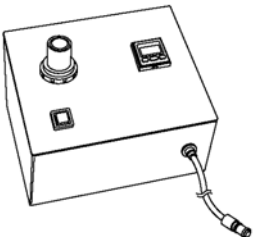
8 Service Fixture & Tools

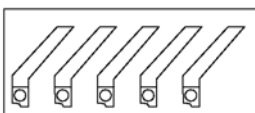
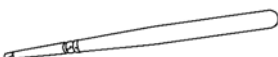
8.1. Service Fixture and Tools

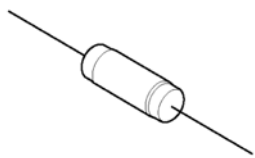
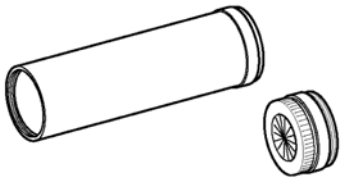
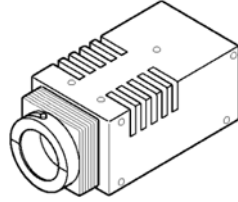
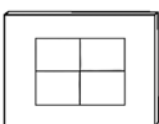
The following Service Fixture and tools are used for checking and servicing this unit.

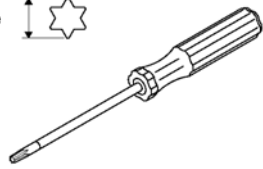
Related to waterproof			
Waterproof packing kit (For waterproof packing replacement) VUMG1863			
Mode Dial O-ring	Rear Button Packing	Case O-ring	Battery Door Packing
			
		Jack Door Plate	Top Button Packing
			
			Screw O-ring × 2
			
Air-leak test jig (For Waterproof property test) RFKZ0528			
	Part No.	Usage	Spec.
	RFKZ0536	DC/banana conversion cable	For power supply
	RFKZ0533	Vacuum pad (2 included)	For power supply
	RFKZ0537	Air-leak test tube (without pad)	For air-leak test
Remarks	Optional goods (1 piece supplied with RFKZ0528)		
Torque driver RFKZ0542			
	Masking sheet RFKZ0540	Silicon chips RFKZ0478	Grease (FLOIL G-31SB) RFKZ0463
(For tightening screws with the torque) * Torque driver (Part No.: RFKZ0456 has short shank and cannot be used for attaching of this unit's Top P.C.B.)	 (For attaching to the microphone part during the air-leak test/5 pieces/sheet)	 (For replacing the packings/ For prevention sticking of dust when replacing the packings)	 (For the Mode dial O-ring)/Wipe the grease attached to the product and apply this grease.)
Resistor for Discharging (1k Ω/5W) ERG5SJ102	Infinity Lens (Built-in Focus Chart) VFK1164TCM02	LIGHT BOX (with DC Cable) VFK1164TDVLB	
 An equivalent type of Resistor may be used.	 ※ RFKZ0422 may be used.		
TR Chart RFKZ0443	Lens Cleaning Kit VFK1900BK	T6 Torque screw driver (For removing the rear aluminium case) VFK1981	
		T6 size 	

8.2. When Replacing the Main PCB

After replacing the MAIN PCB, be sure to achieve adjustment.

The adjustment instruction is available at "software download" on the "Support Information from NDBG/VDBG-AVC" web-site in "TSN system", together with Maintenance software.

8.3. Service Position

This Service Position is used for checking and replacing parts. Use the following Extension cables for servicing.

Table S1 Extension Cable List

No.	Parts No.	Connection	Form
1	RFKZ0416	FP9003 (Main P.C.B.) - Lens with CCD unit (CCD section)	41PIN 0.3 FFC
2	RFKZ0416	FP9002 (Main P.C.B.) - Lens with CCD unit (Lens section)	41PIN 0.3 FFC
3	VFK1364	FP9001 (Main P.C.B.) - FT6301 (Top P.C.B.)	14PIN 0.5 FFC
4	VFK1174	FP9004 (Main P.C.B.) - Rear Operation P.C.B.	16PIN 0.5 FFC

8.3.1. Extension Cable Connections

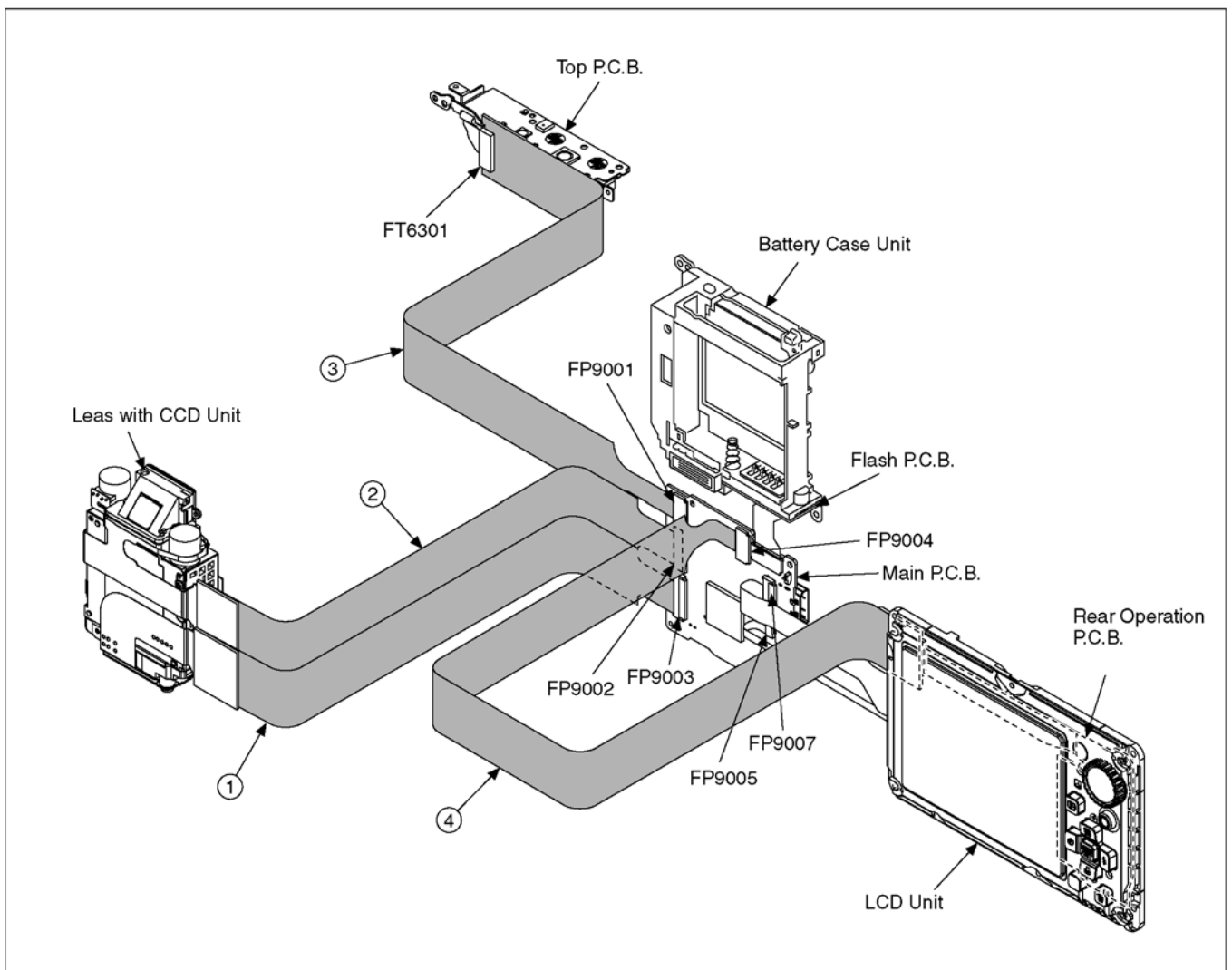

Note when repairing PCB

In this unit, battery door lock detection switch is mounted on Main PCB so as to secure the waterproof performance.

Be careful of following points.

(1) Before removing Main PCB, be sure to cancel Initial setting.

If the unit is turned on while Battery Door is not locked correctly, the following warning display as right figure appears on LCD, and this unit cannot be operated.

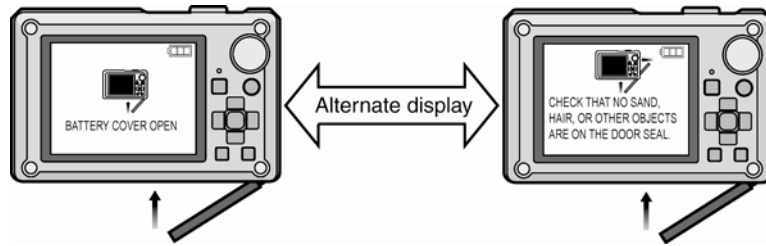

When Main PCB was removed, this battery door lock detection switch becomes to status of "Battery Door: OPEN".

Thus battery door lock detection switch does not operate correctly.

And even if the unit is turned on, this unit cannot be operated.

When initial setting was cancelled, battery door lock detection switch is ignored and the unit always be in status of "Battery Door: CLOSE" and the unit can be operated even if Main PCB is removed.

CAUTION-1. (When servicing FLASH PCB)

1. Be sure to discharge the capacitor on FLASH PCB.

Refer to "HOW TO DISCHARGE THE CAPACITOR ON FLASH PCB".

The capacitor voltage is not lowered soon even if the AC Cord is unplugged or the battery is removed.

2. Be careful of the high voltage circuit on FLASH PCB.

3. DO NOT allow other parts to touch the high voltage circuit on FLASH PCB.

9 Disassembly and Assembly Instructions

9.1. Disassembly Flow Chart

- Make sure to perform air-leak test (refer to "7.1. Service and Check Procedures" before disassembly and after assembly for check of waterproof property.
- Do not touch the waterproof packings directly by the hand.
- Do not perform cleaning of waterproof packings by the solvent of alcohol etc. or by blowing air .
- Take care not to put any foreign object (garbage and dust).
- When replacing the case O-ring, use Silicon chips (RFKZ0478).
- When replacing Mode dial O-ring, wipe the grease applied to the product first, then apply grease (RFKZ0463).
- When tightening screws, follow the specifications when the torque is specified .

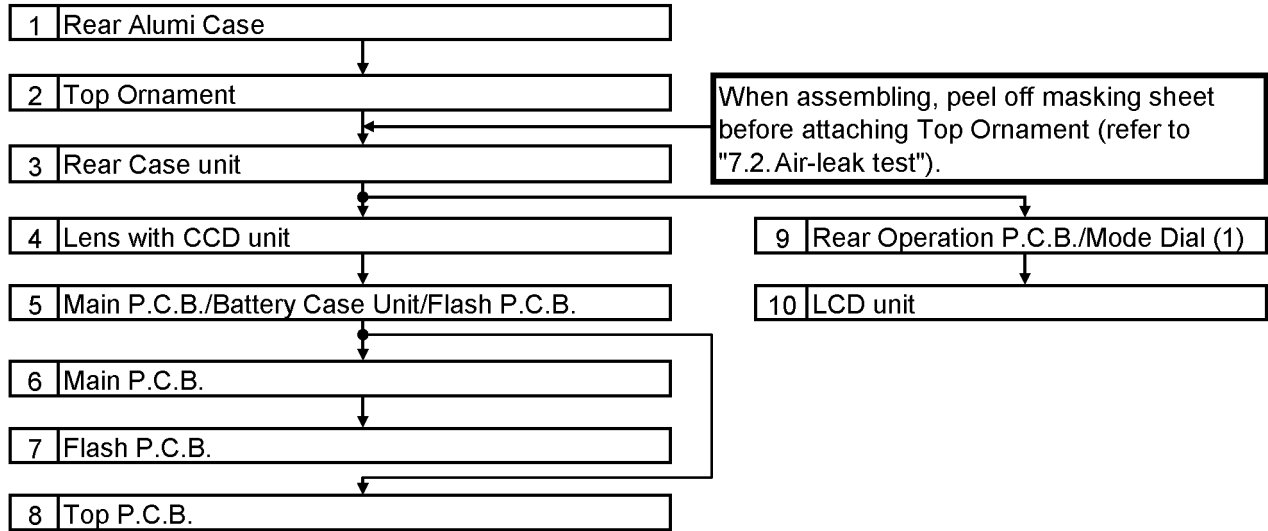

9.2. PCB Location

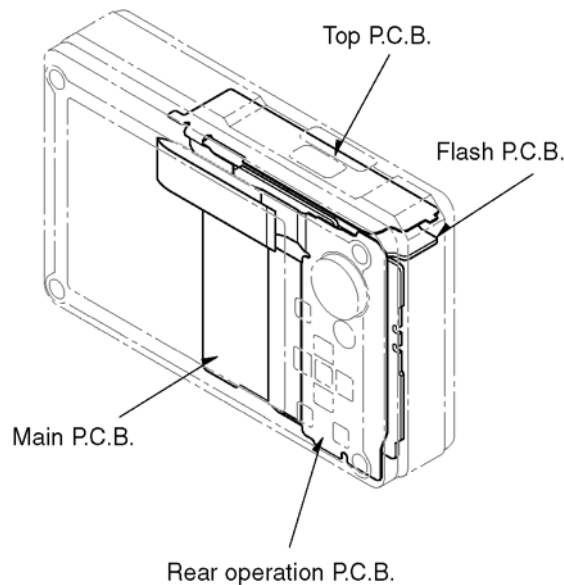

9.3. Disassembly Procedures

No.	Item	Fig.	Removal		
1	Rear Alumi Case	Fig. D1	Card		
			Battery		
			4 Screws (A)		
			2 Screws (B)		
2	Top Ornament, Shutter Button, Power (ON/OFF) Button Zoom Slide Lever	Fig. D2	2 Screws (C)		
			Top Ornament		
		Fig. D3	Shutter Button		
			Power (ON/OFF) Button Zoom Slide Lever		
3	Rear Case Unit	Fig. D4	4 Screws (D) (Tightening torque is regretted)		
			2 Screws (E) (Tightening torque is regretted)		
			FP9004 (Flex)		
			FP9005 (Flex)		
			FP9007 (Flex)		
			Rear Case Unit		
			Fig. D5	Note when attaching Rear Case Unit	
			4	Lens with CCD Unit	Fig. D6
		5 Screws (F)			
		5	Main P.C.B., Battery Case Unit	Fig. D6	1 Screws (G)
Screw O-ring					
Fig. D7	FP9002 (Flex)				
	FP9003 (Flex)				
	Lens Plate				
	Lens with CCD Unit				
	Fig. D7			Note when attaching Busterraid Sheet	
	Fig. D8			Note before removal of Main P.C.B.	
				1 Screws (H)	
	Fig. D9			FP9001 (Flex)	
Main P.C.B., Battery Case Unit					
6	Main P.C.B.	Fig. D10	FP9006 (Flex)		
			Tab × 1		
			1 Screws (I)		
			1 Screws (J)		
			Tab × 1		
			Main P.C.B.		
7	Flash P.C.B.	Fig. D11	Note after replacing Main P.C.B.		
			Fig. D12	1 Screws (K)	
8	Top P.C.B.	Fig. D13	Tab × 2		
			FL Earth Plate		
		Fig. D14	Flash P.C.B.		
			1 Screws (L)		
9	Rear Operation P.C.B. Mode Dial (1)	Fig. D15	Screw O-ring		
			5 Screws (M)		
		Fig. D16	Top P.C.B.		
			Fig. D17	Peel of Barrier Sheet	
10	LCD Unit	Fig. D18	9 Screws (N)		
			Rear FPC Plate		
			Rear Operation P.C.B.		
			1 Screws (O)		
			Mode Dial Piece Mode Dial O-ring Mode Dial (1)		

9.3.1. Removal of Rear Alumi Case

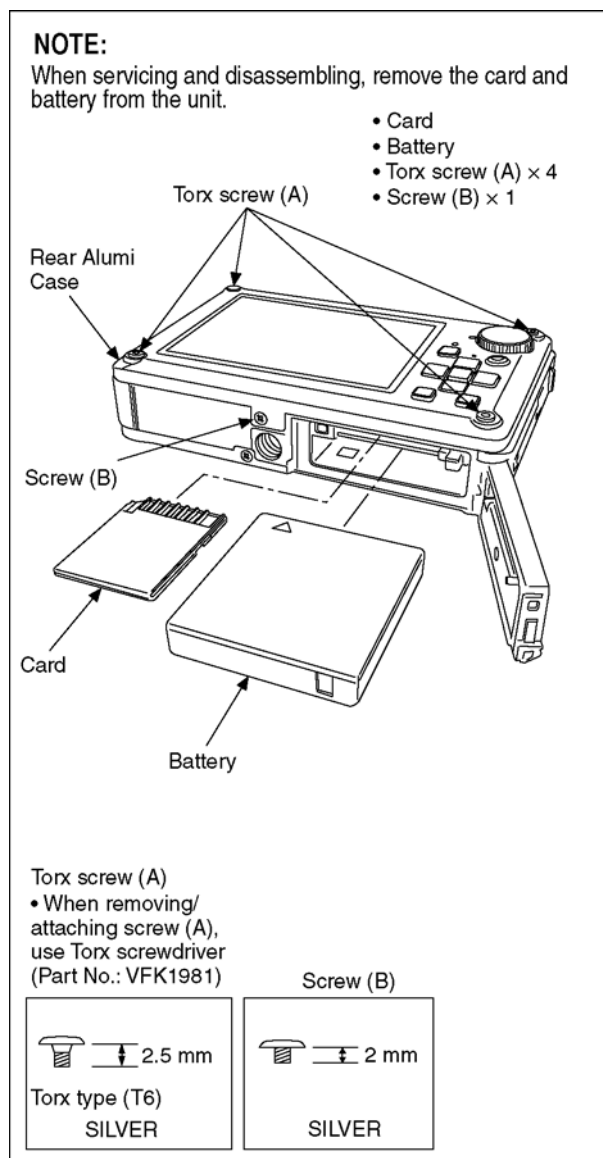

Fig. D1

9.3.2. Removal of Top Ornament

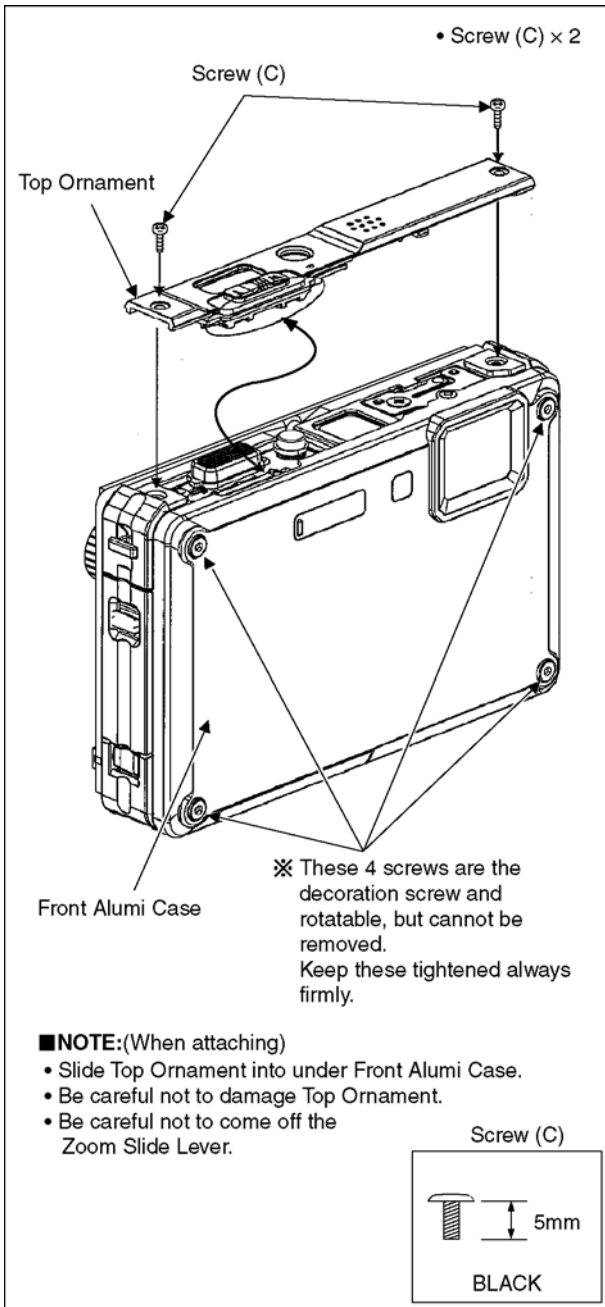

Fig. D2

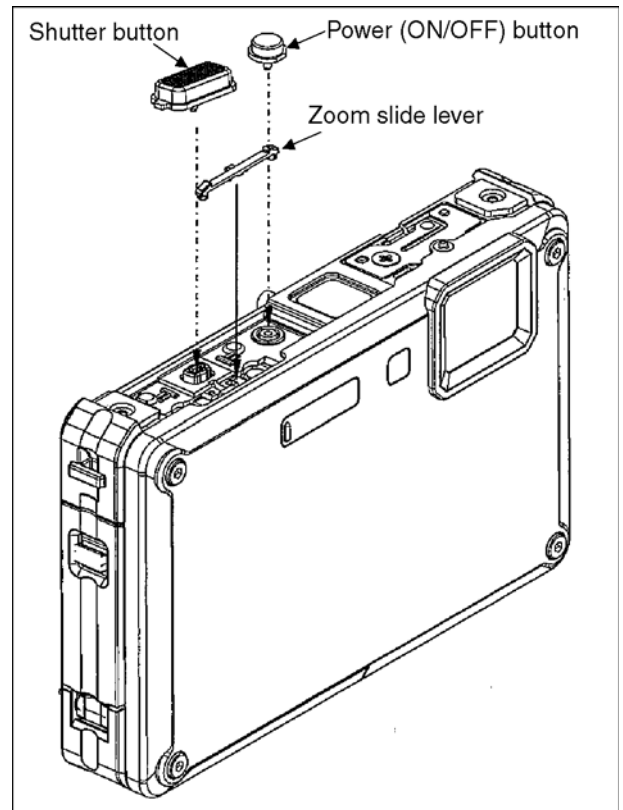

Fig. D3

9.3.3. Removal of Rear Case Unit

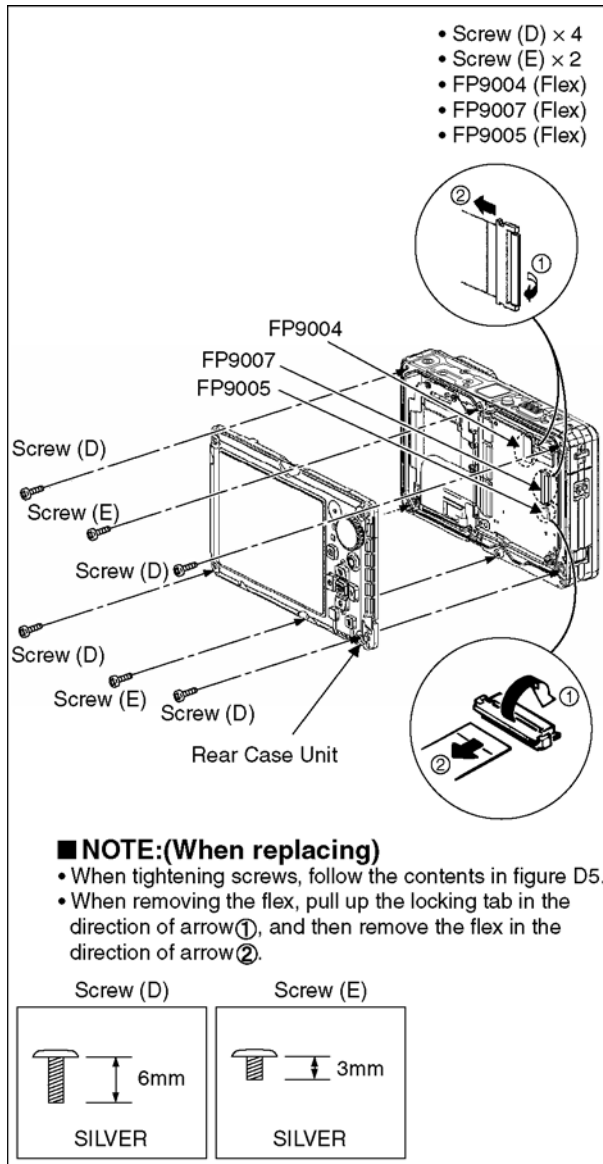
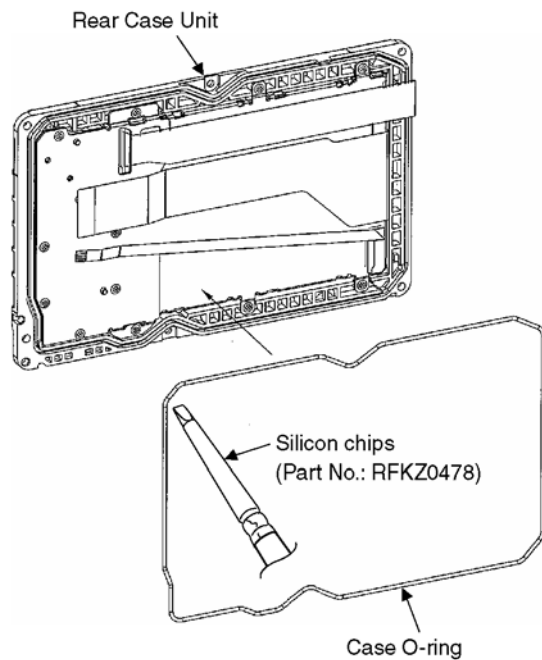

Fig. D4

SCREW TIGHTENING NOTE: TYPE/ORDER/TORQUE

NOTE: (When attaching the rear case)

- Do not insert the Flex from any slanted angle. Insert the Flex fully.
- Make sure the connector is firmly locked.
- When attaching Case O-ring, use Silicon chips (Part No.: RFKZ0478).
- Make sure the O-ring of rear case does not come off.
- Make sure foreign objects are not attached to the O-ring and the waterproof lib of the front case.
- When tighten the screws, use Torque screwdriver (Part No.: RFKZ0542) and tighten by the specified torque.
- Tighten the screws in the order of (1) to (6) as shown below.
- To keep waterproof property, be careful type of screw, screwing order and tightening torque.



Order of tightening screws/tightening torque

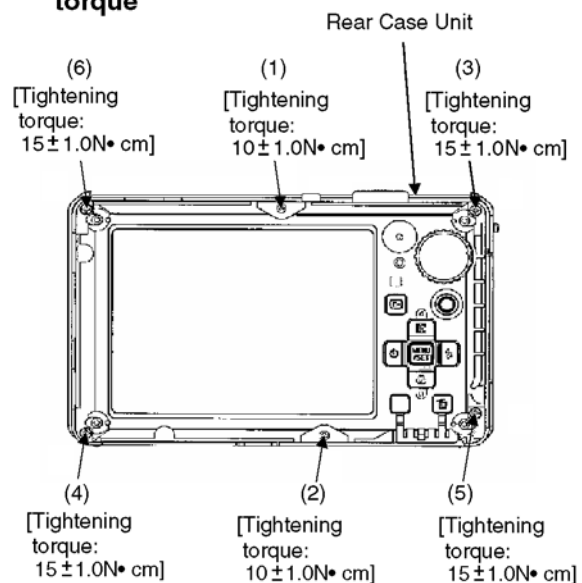

Fig. D5

9.3.4. Removal of Lens with CCD Unit

NOTE: (When Disassembling/Assembling)

1. When dust stuck, use air-Blower to blow off the dust.
2. Do not touch the surface of lens by your hand.
3. Use Lens Cleaning KIT; VFK1900BK (Only supplied as 10 set/Box) is available as Service Aid.

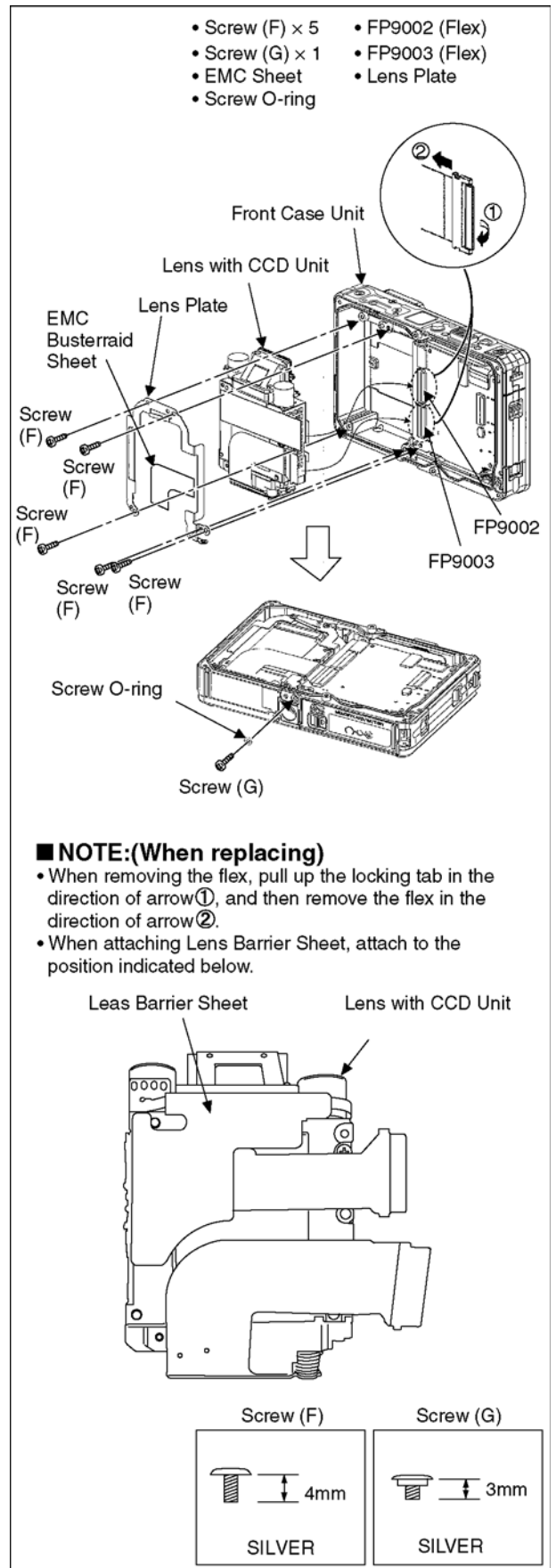

Fig. D6

9.3.5. Removal of Main P.C.B., Battery Case

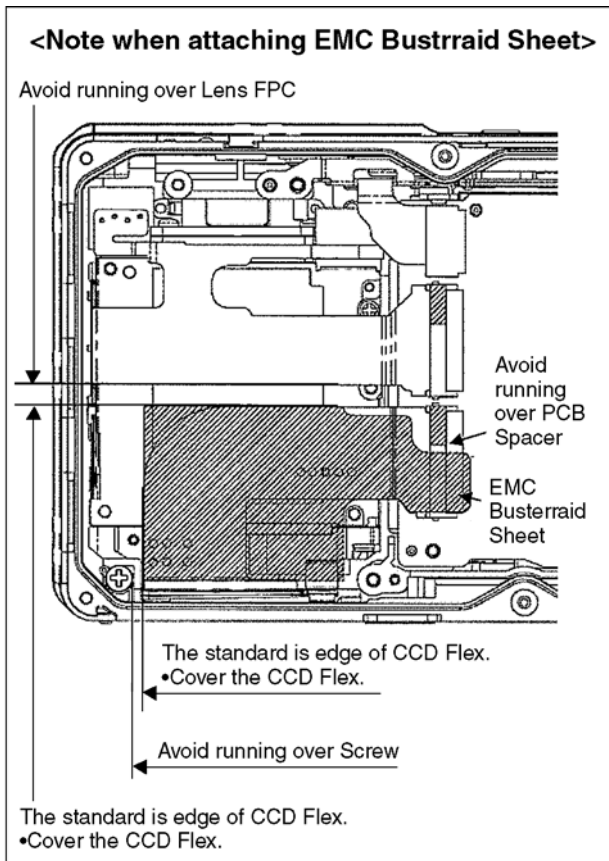

Fig. D7

■ NOTE: (Before removing Main P.C.B.)

When Main P.C.B. is removed while Initial setting is not cancelled, Battery door lock detection switch does not operate correctly, and the unit cannot be operated (refer to following figure).

To operate removed Main P.C.B., cancel the Initial setting before removing Main P.C.B. (refer to "3.5.2. INITIAL SETTINGS").

(While Initial setting is cancelled, Battery door lock detection switch is ignored.)

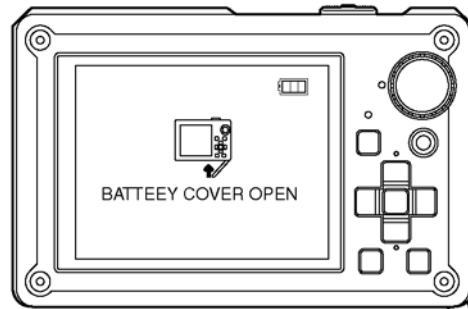

<LCD display when battery door is opened>

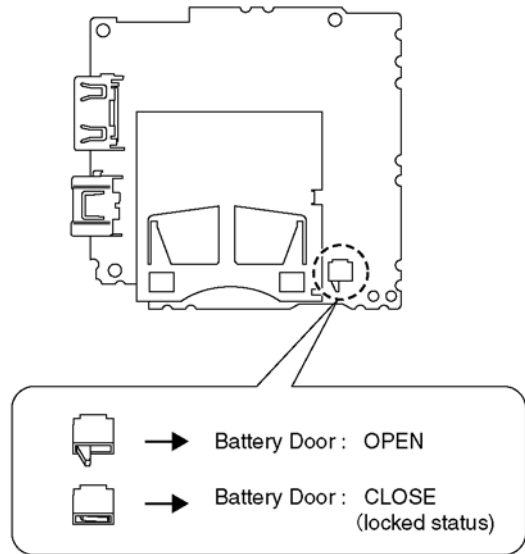
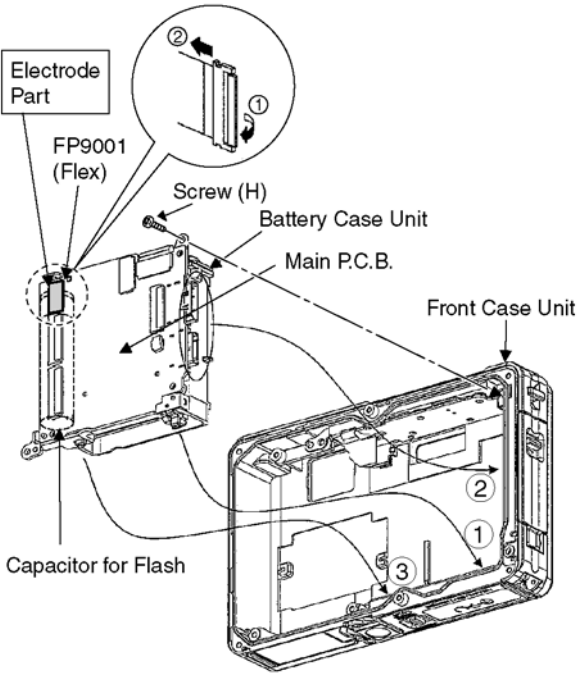

Fig. D8

<Caution:>

To avoid electric shock, do not touch the electrode part of the flash condenser when removing the battery case.

- Screw (H) x 1
- FP9001 (Flex)



NOTE:(When replacing Main P.C.B.)

Note the following because Battery door lock detection switch is mounted on Main P.C.B.

- Perform removing Main P.C.B. while Battery Door is closed.
- Perform attaching Main P.C.B. while Battery Door is opened. (When Battery door is closed, ★ part is not locked with the unit.)

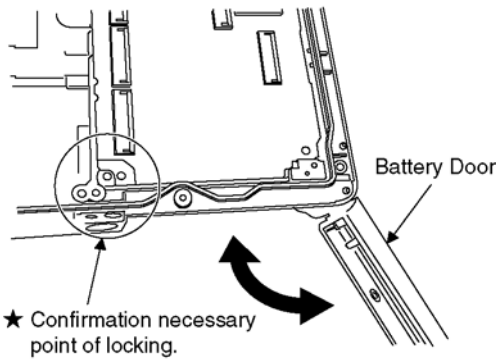

NOTE:(When replacing)

- When removing the flex, pull up the locking tab in the direction of arrow ①, and then remove the flex in the direction of arrow ②.

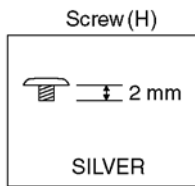

Fig. D9

9.3.6. Removal of Main P.C.B.

< CAUTION >

To avoid electric shock, follow the procedure below to be sure to discharge the capacitor on Flash P.C.B.

[Discharging Procedure]

1. Put the insulation tube onto the lead part of Resistor (ERG5SJ102:1kΩ/5W).
2. Put the resistor between both terminals of capacitor on Flash P.C.B. for approx. 5 seconds.
3. Discharge completion.

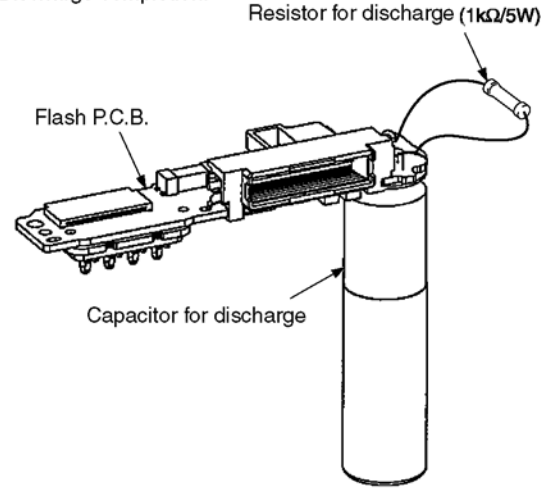

- Screw (I) x 1
- Screw (J) x 1
- Tab x 1
- FP9006 (Flex)

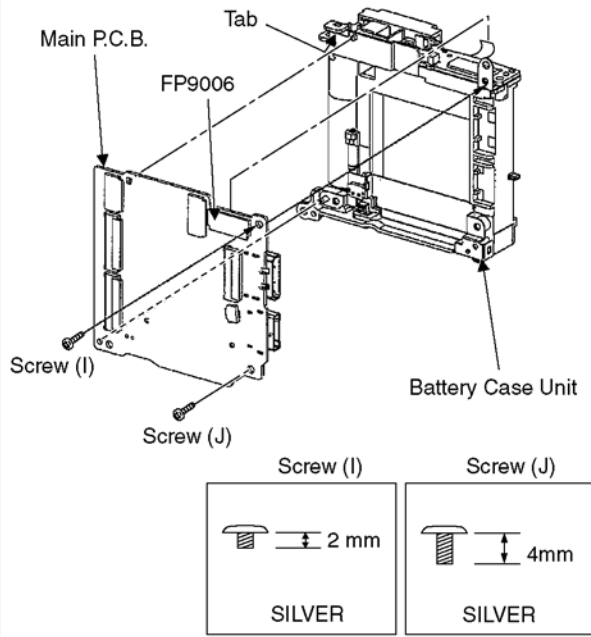

Fig. D10

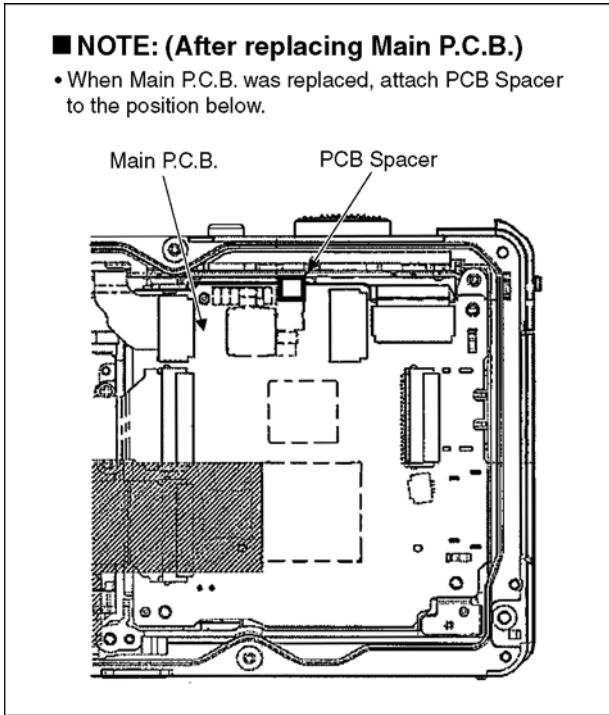

Fig. D11

9.3.7. Removal of Flash P.C.B.

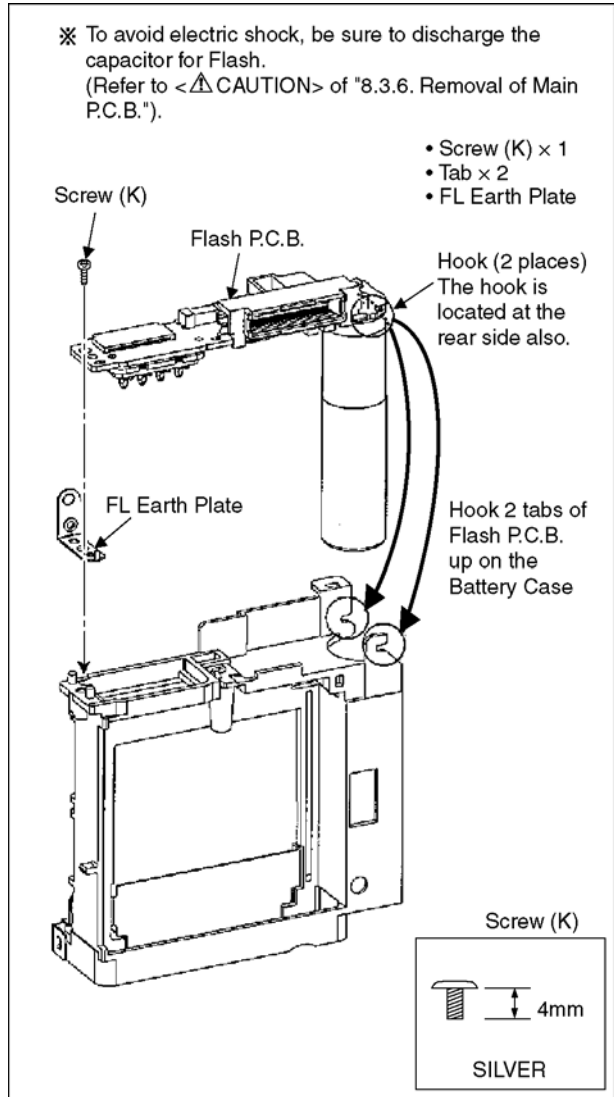

Fig. D12

9.3.8. Removal of Top P.C.B.

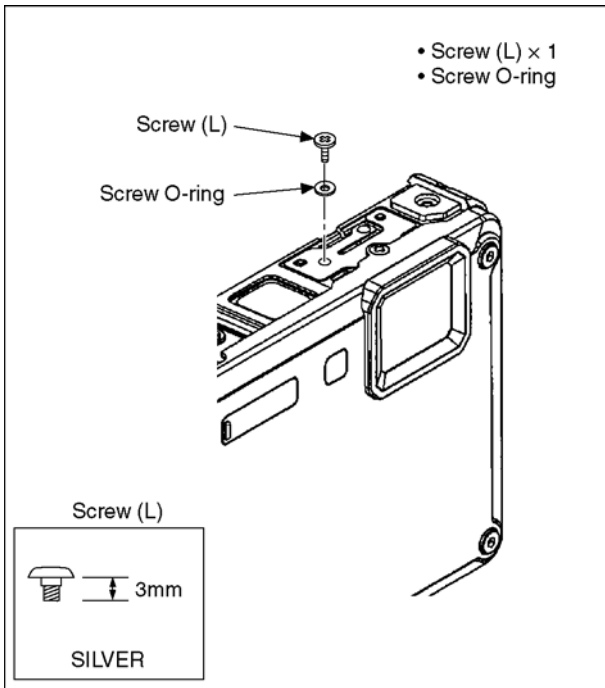

Fig. D13

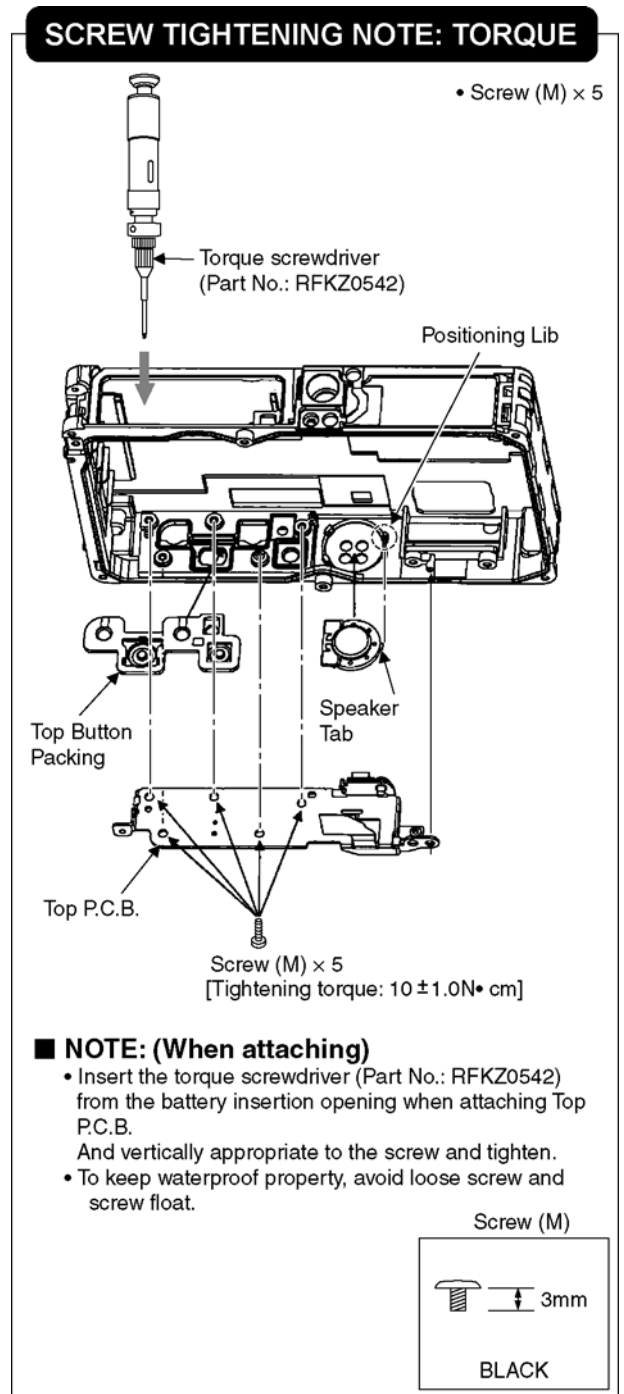

Fig. D14

9.3.9. Removal of Rear Operation P.C.B.

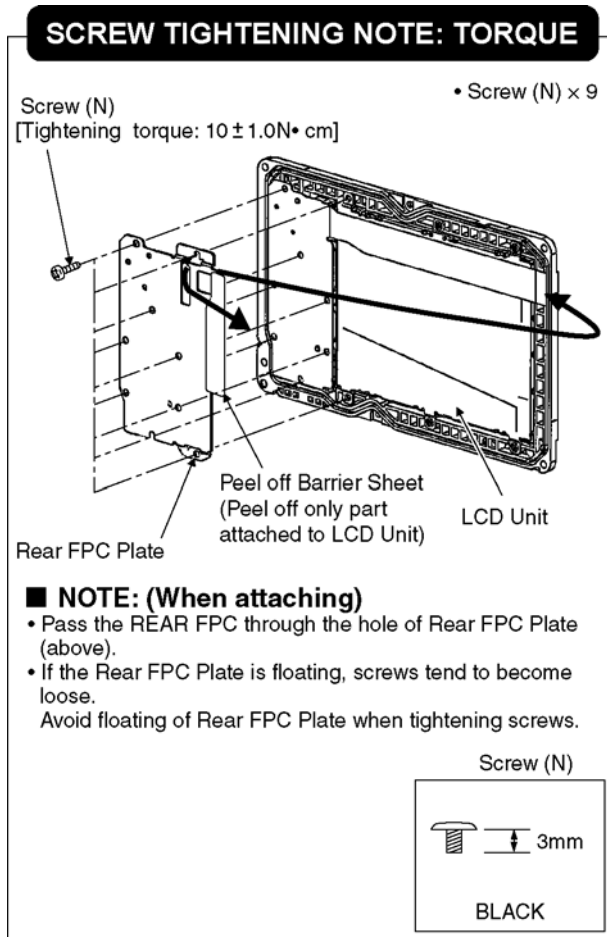

Fig. D15

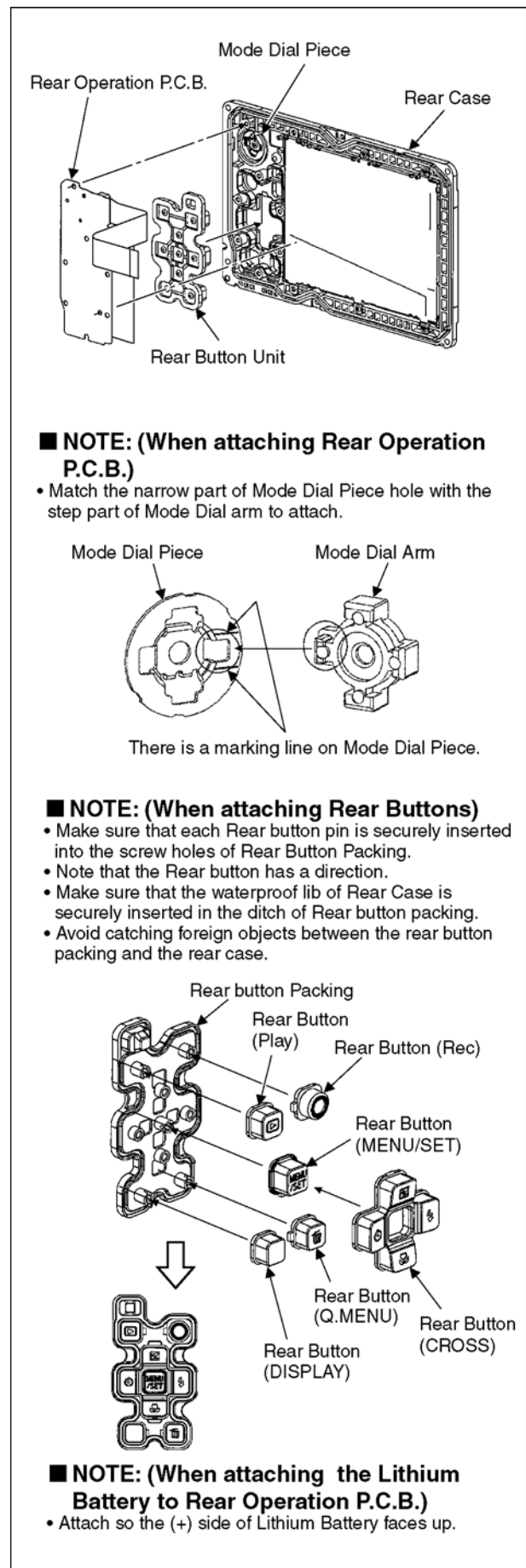

Fig. D16

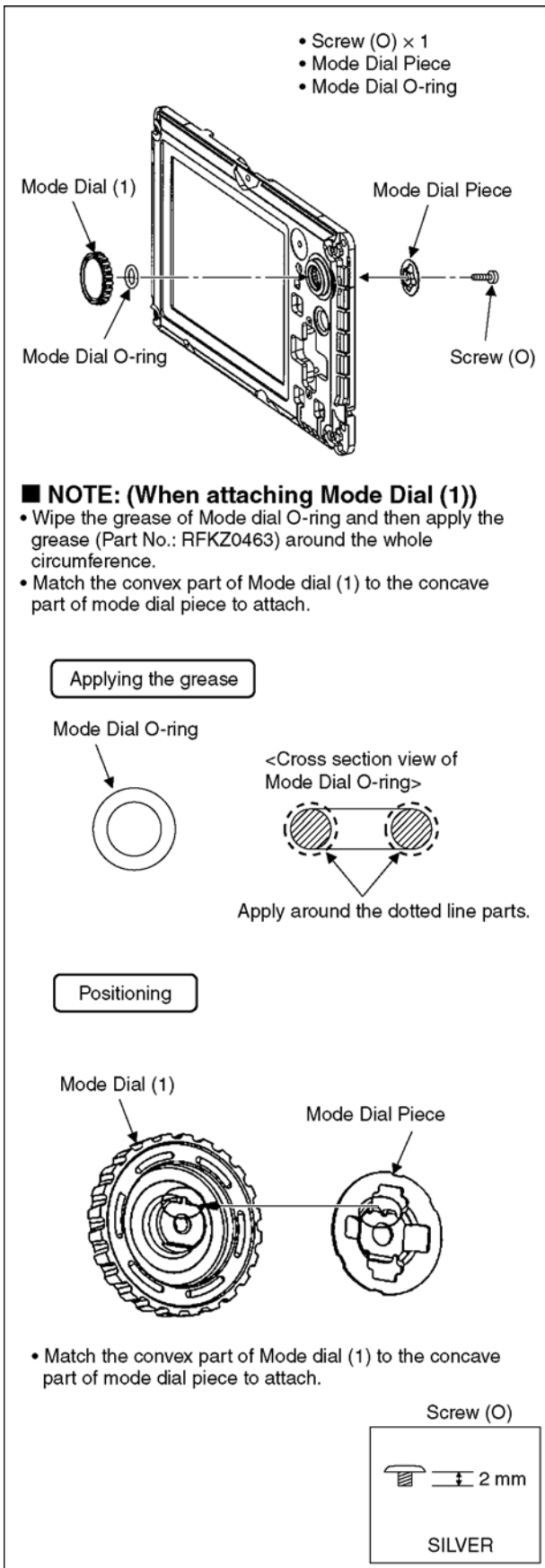

Fig. D17

9.3.10. Removal of LCD Unit

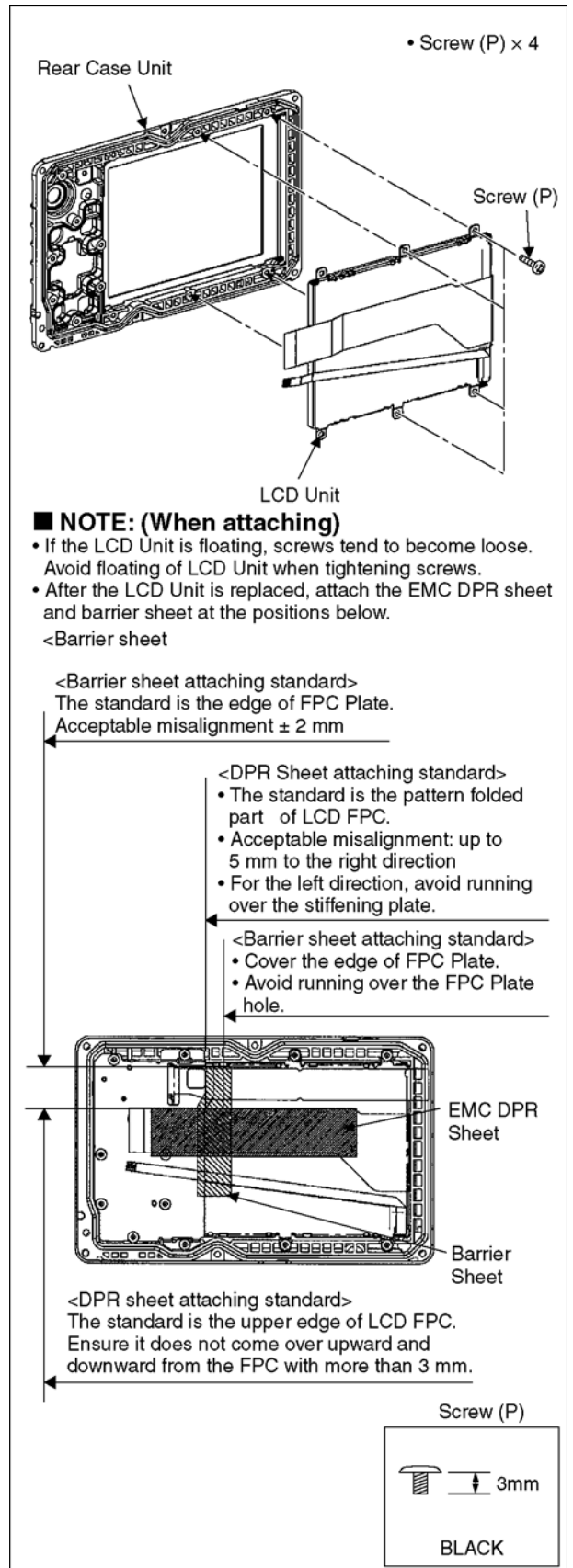

Fig. D18

10 Measurements and Adjustments

10.1. Matrix Chart for Replaced Part and Necessary Adjustment

The relation between Replaced part and Necessary Adjustment is shown in the following table.

When concerned part is replaced, be sure to achieve the necessary adjustment(s).

As for Adjustment condition/procedure, consult the "Adjustment Manual" which is available in Adjustment software.

The Adjustment software is available at "TSN Web-site", therefore, access to "TSN Web-site" at "Support Information from NWBG/VDBG-AVC".

NOTE:

After adjustments have been terminated, make sure to achieve "INITIAL SETTINGS".

Adjustment Item		Replaced Part				
		Main P.C.B.	VENUS (IC6001)	Flash-ROM (IC6002)	Lens Part with CCD	LCD/EVF
Camera Section	OIS hall element adjustment (OIS)	○	○	○	○	-
	Back focus adjustment (BF)	○	○	○	○	-
	Shutter adjustment (SHT)	○	○	○	○	-
	ISO sensitivity adjustment (ISO)	○	○	○	○	-
	AWB adjustment High brightness coloration inspection (WBL)	○	○	○	○	-
	Linearity adjustment (LIN)	○	○	○	○	-
	CCD white scratch compensation (WKI)	○	○	○	○	-
	CCD black scratch compensation (BKI)	○	○	○	○	-

NOTE:

*There is no LCD and EVF adjustment in this model.

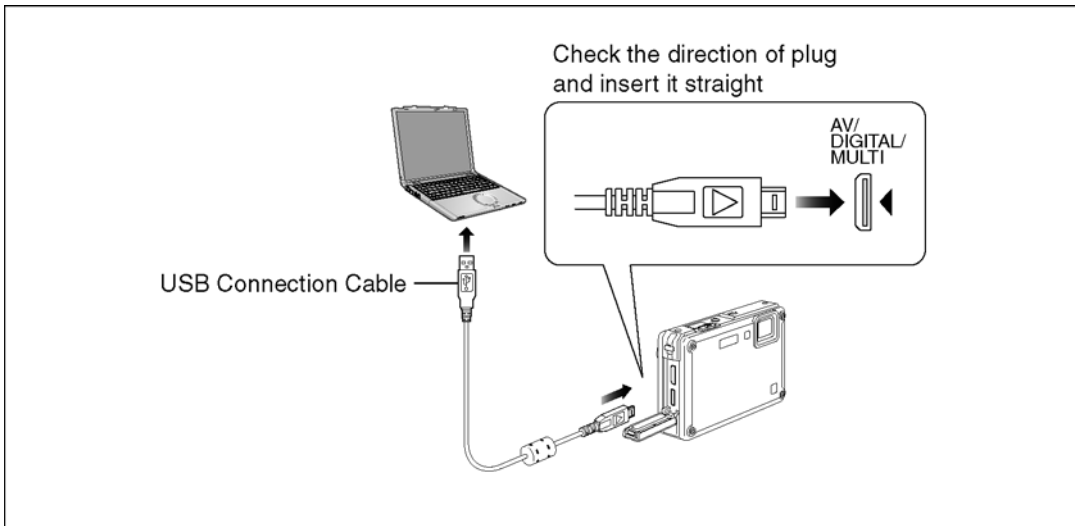

11 Maintenance

11.1. Cleaning Lens and LCD Panel

Do not touch the surface of lens and LCD Panel with your hand.

When cleaning the lens, use air-Blower to blow off the dust.

When cleaning the LCD Panel, dampen the lens cleaning paper with lens cleaner, and the gently wipe the their surface.

Note:

The Lens Cleaning KIT ; VFK1900BK(Only supplied as 10 set/Box) is available as Service Aid.

Service Manual

Diagrams and Replacement Parts List

Digital Camera

Model No.

DMC-FT1EB	DMC-FT1SG
DMC-FT1EE	DMC-TS1GH
DMC-FT1EF	DMC-TS1GK
DMC-FT1EG	DMC-TS1GT
DMC-FT1EP	DMC-TS1P
DMC-FT1GC	DMC-TS1PC
DMC-FT1GJ	DMC-TS1PU
DMC-FT1GN	

Vol. 1

Colour

- (S).....Silver Type (except EF/GT)
- (A).....Blue Type (only EB/EF/EG/EP/GC/GN/PC/PU)
- (D).....Orange Type (except EB)
- (G).....Green Type (except EB)

Table of contents

S1. About Indication of The Schematic Diagram..... S-1	S6. Replacement Parts List..... S-11
S1.1. Important Safety Notice..... S-1	
S2. Voltage Chart S-2	S7. Exploded View S-15
S2.1. Flash P.C.B. S-2	S7.1. Frame and Casing Section..... S-15
S3. Block Diagram..... S-3	S7.2. Packing Parts and Accessories Section..... S-16
S3.1. Overall Block Diagram S-3	
S4. Schematic Diagram..... S-4	
S4.1. Interconnection Diagram S-4	
S4.2. Flash Schematic Diagram S-5	
S4.3. Top Operation Schematic Diagram S-6	
S4.4. Rear Operation Schematic Diagram S-7	
S5. Print Circuit Board S-8	
S5.1. Flash P.C.B. S-8	
S5.2. Top Operation P.C.B..... S-9	
S5.3. Rear Operation P.C.B..... S-10	

S1. About Indication of The Schematic Diagram

S1.1. Important Safety Notice

COMPONENTS IDENTIFIED WITH THE MARK \triangle HAVE THE SPECIAL CHARACTERISTICS FOR SAFETY. WHEN REPLACING ANY OF THESE COMPONENTS USE ONLY THE SAME TYPE.

1. Although reference number of the parts is indicated on the P.C.B. drawing and/or schematic diagrams, it is NOT mounted on the P.C.B. when it is displayed with "\$" mark.
2. It is only the "Test Round" and no terminal (Pin) is available on the P.C.B. when the TP (Test Point) indicated as "●" mark.
3. The voltage being indicated on the schematic diagram is measured in "Standard-Playback" mode when there is no specify mode is mentioned.
4. Although the voltage and waveform available on here is measured with standard frame, it may be differ from actual measurement due to modification of circuit and so on.
5. The voltage being indicated here may be include observational-error (deviation) due to internal-resistance and/or reactance of equipment. Therefore, handle the value indicated on here as reference.
6. Use the parts number indicated on the Replacement Parts List .
7. Indication on Schematic diagrams:

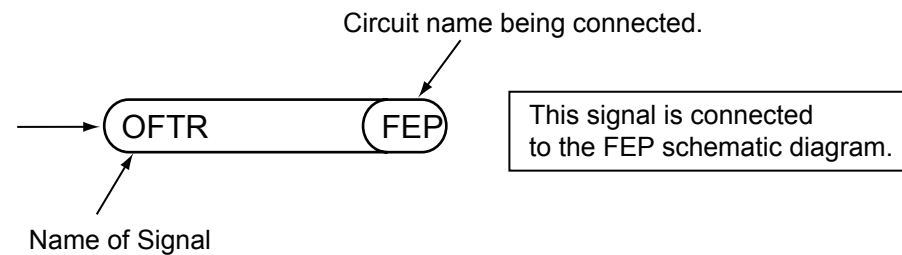

S2. Voltage Chart

Note) Indicated voltage values are the standard values for the unit measured by the DC electronic circuit tester (high-impedance) with the chassis taken as standard.
Therefore, there may exist some errors in the voltage values, depending on the internal impedance of the DC circuit tester.

S2.1. Flash P.C.B.

REF No.	PIN No.	POWER ON
IC8001	1	3
IC8001	2	0
IC8001	3	0
IC8001	4	0
IC8001	5	3.3
Q8001	1	5.1
Q8001	2	5.1
Q8001	3	0
Q8001	4	0
Q8001	5	5.1
Q8001	6	5.1

S4. Schematic Diagram

S4.1. Interconnection Diagram

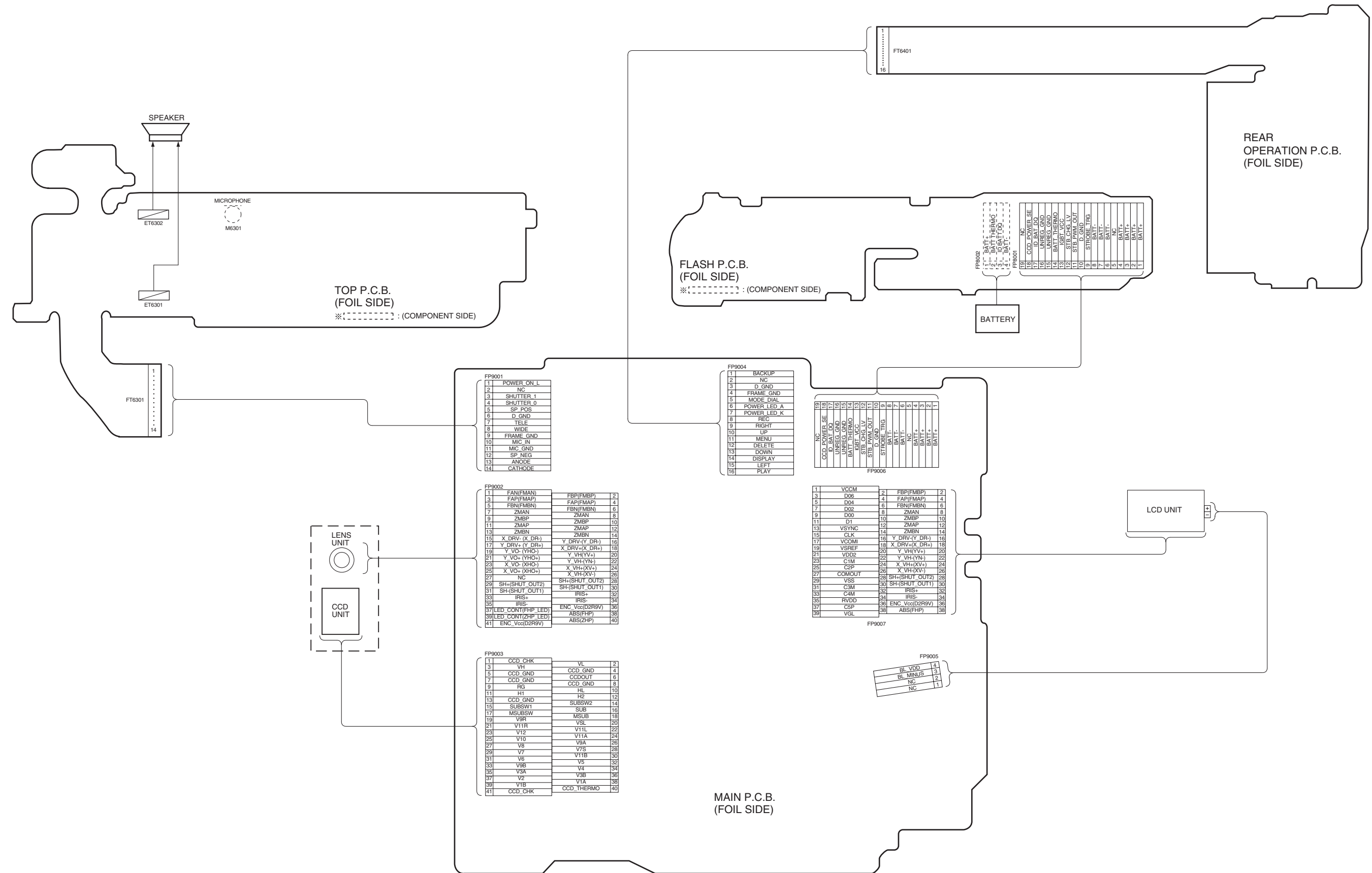

S4.2. Flash Schematic Diagram

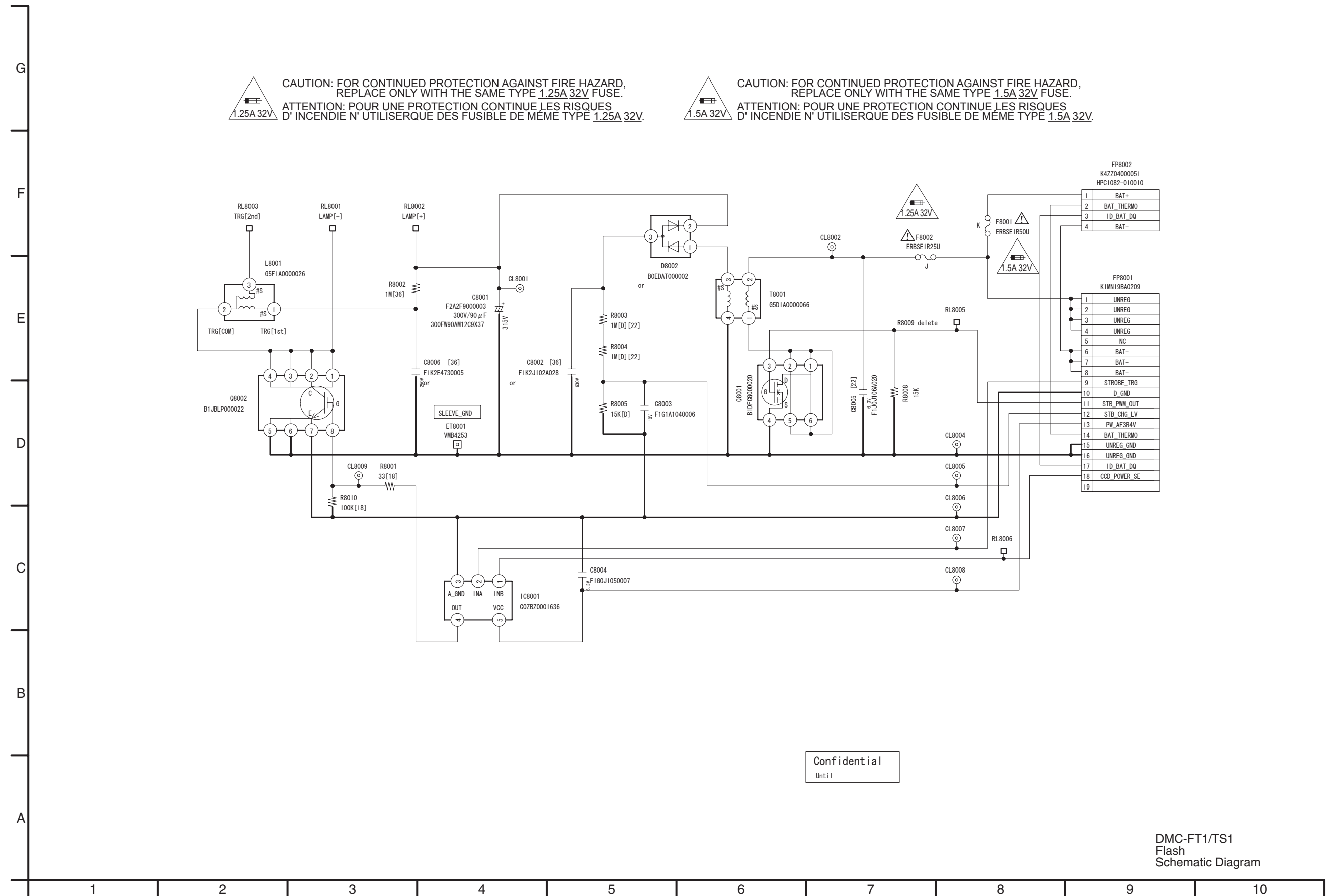

Confidential
Until

S4.3. Top Operation Schematic Diagram

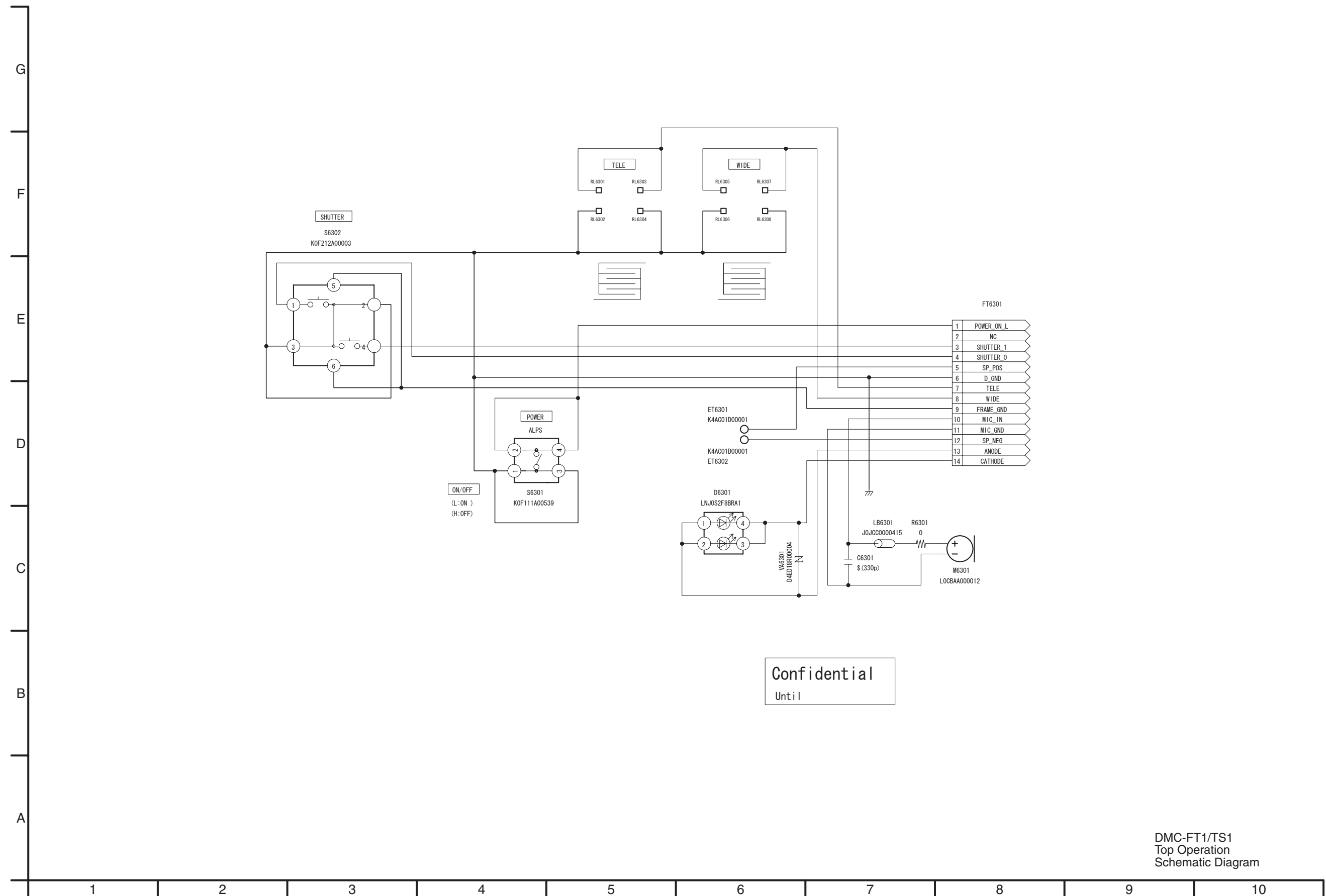

Confidential
Until

S4.4. Rear Operation Schematic Diagram

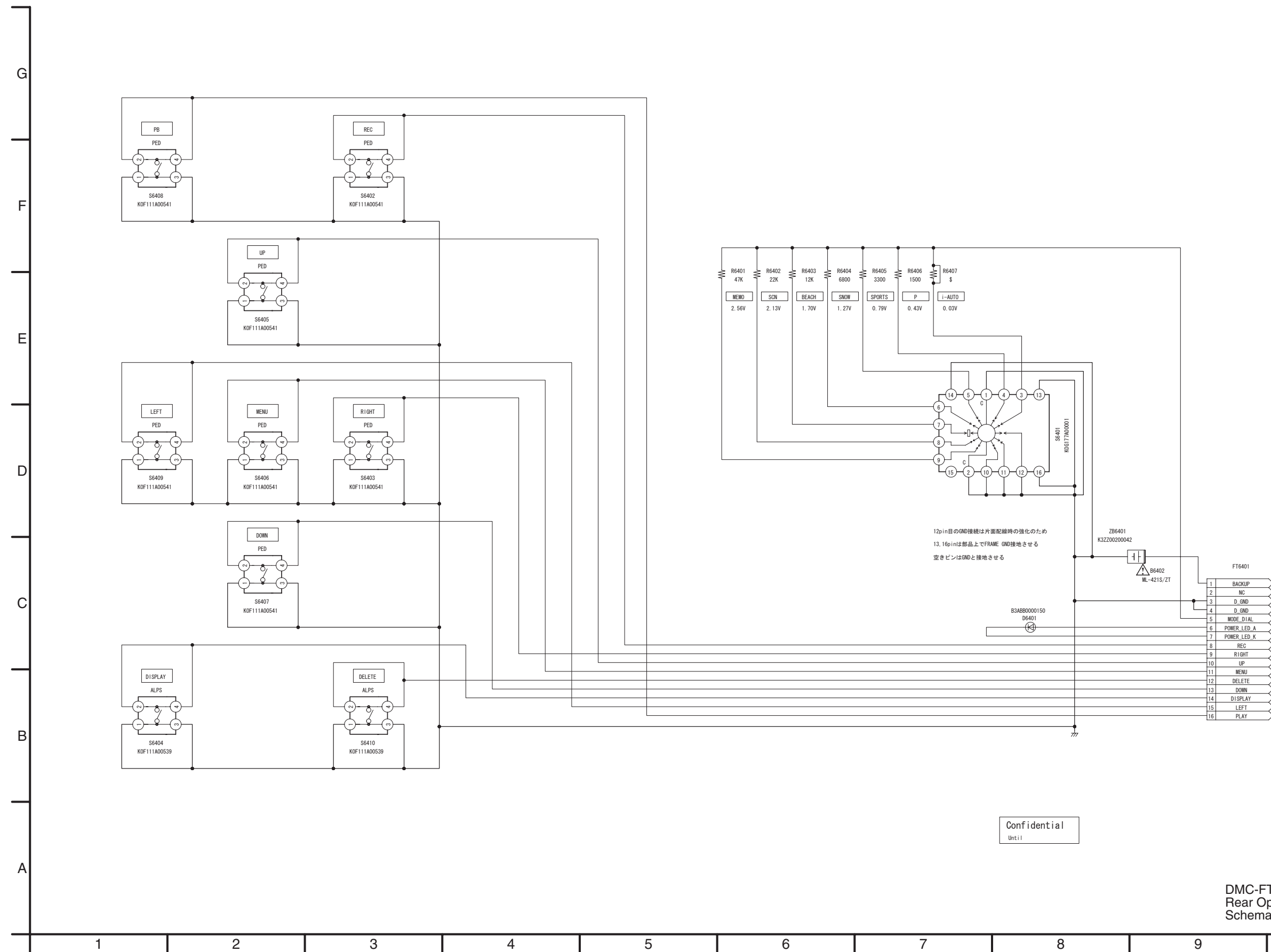

DMC-FT1/TS1
 Rear Operation
 Schematic Diagram

S5. Print Circuit Board

S5.1. Flash P.C.B.

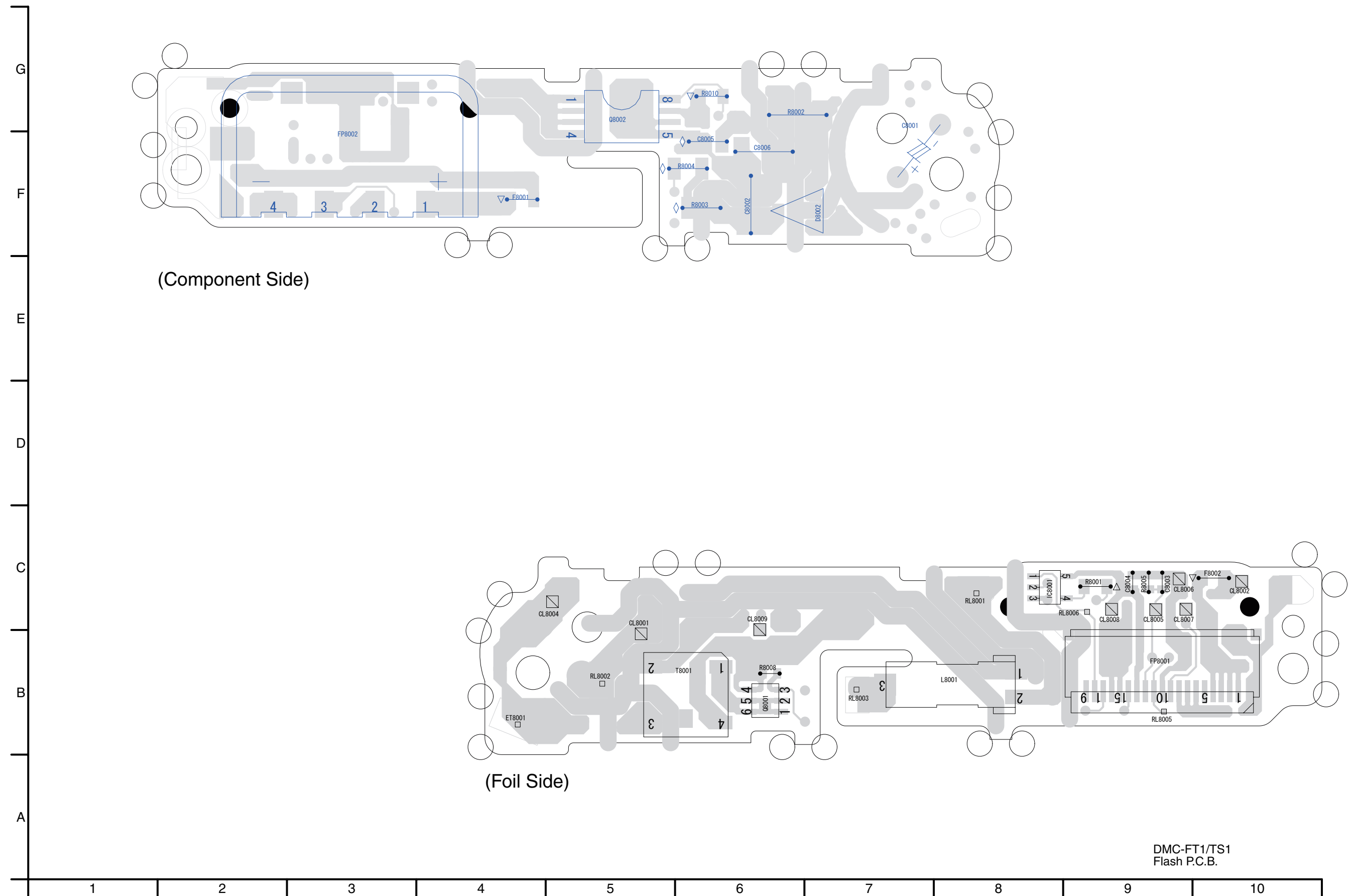

S5.2. Top Operation P.C.B.

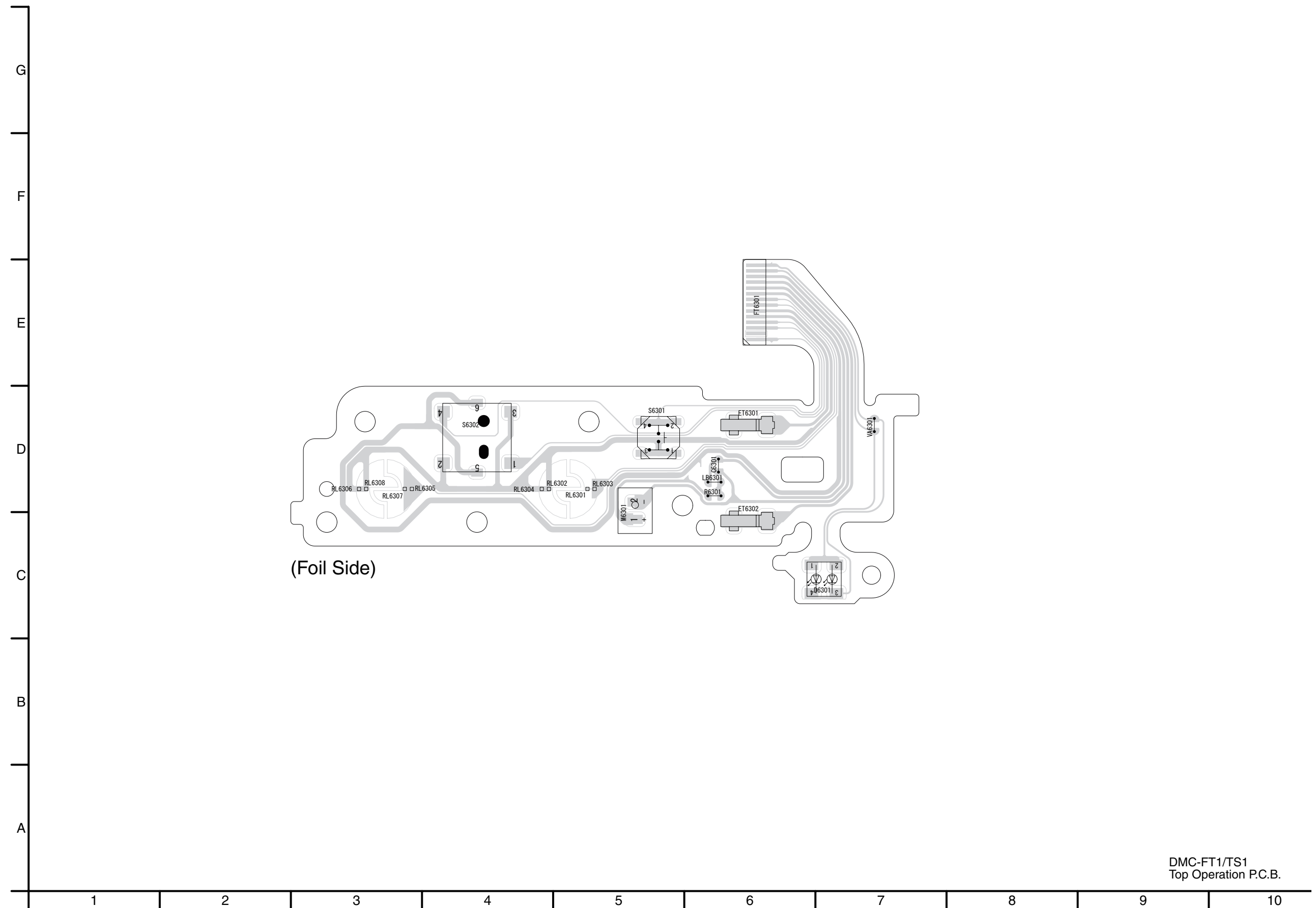

S5.3. Rear Operation P.C.B.

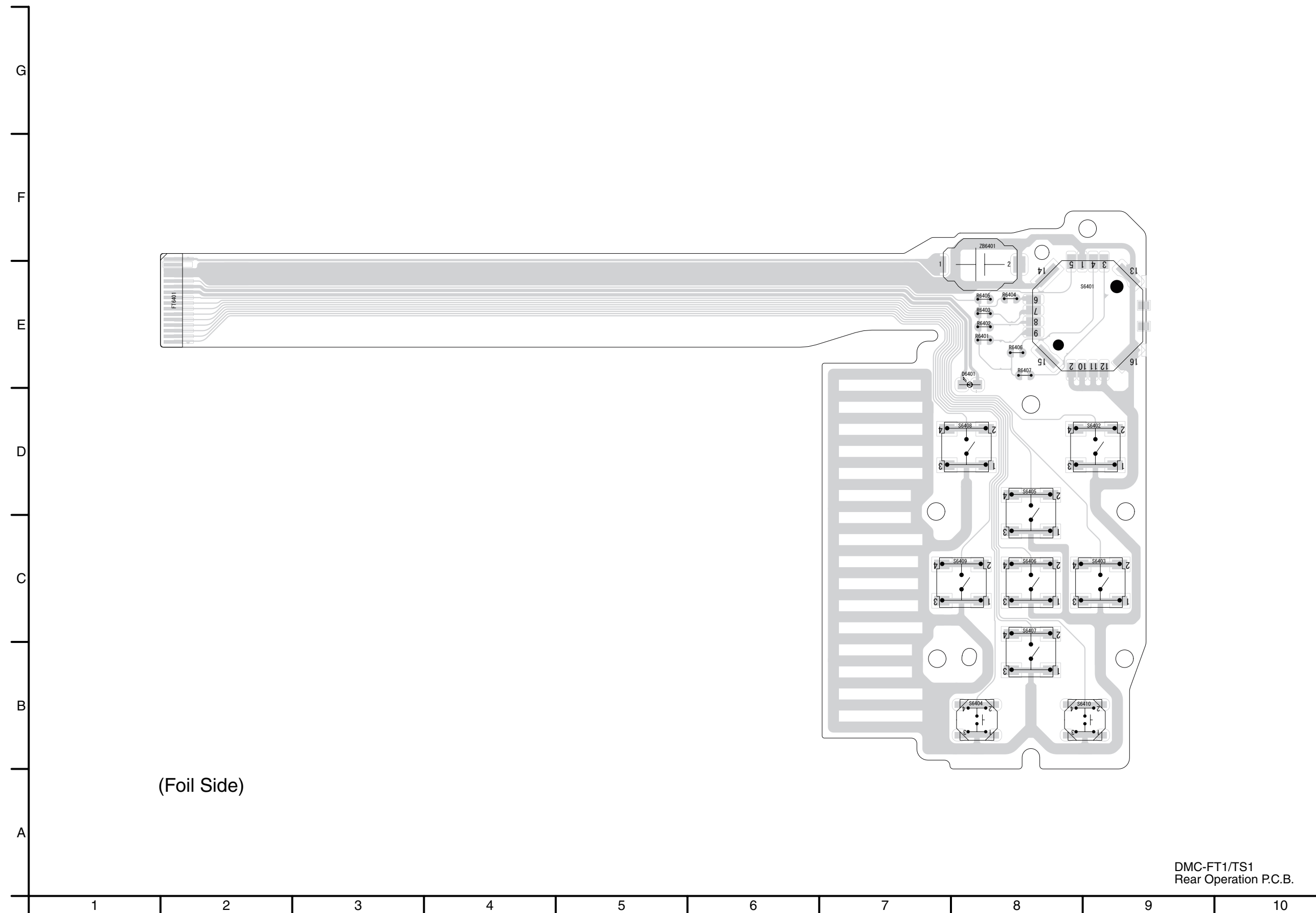

(Foil Side)

DMC-FT1/TS1
Rear Operation P.C.B.

S6. Replacement Parts List

- Note: 1.* Be sure to make your orders of replacement parts according to this list.
2. IMPORTANT SAFETY NOTICE
Components identified with the mark \triangle have the special characteristics for safety.
When replacing any of these components, use only the same type.
3. Unless otherwise specified,
All resistors are in OHMS, K=1,000 OHMS. All capacitors are in MICRO-FARADS (uf), P=uuF.
4. The marking (RTL) indicates the retention time is limited for this item. After the discontinuation of this assembly in production, it will no longer be available.
5. Supply of CD-ROM, in accordance with license protection, is allowable as replacement parts only for customers who accidentally damaged or lost their own.

E.S.D. standards for Electrostatically Sensitive Devices, refer to PREVENTION OF ELECTROSTATIC DISCHARGE (ESD) TO ELECTROSTATICALLY SENSITIVE (ES) DEVICES section.

Definition of Parts supplier:

1. **Parts marked with [ENERGY] in the remarks column are supplied from Panasonic Corporation Energy Company.**
Others are supplied from AVC-CSC-SPC.

DMC-FT1EB/EE/EF/EG/EP/GC/GJ/GN/SG, TS1GH/GK/GT/P/PC/PU

Ref.No.	Part No.	Part Name & Description	Pcs	Remarks	Ref.No.	Part No.	Part Name & Description	Pcs	Remarks
1	VKM7954	REAR ALUMI CASE	1	(-A)	B1	VHD2067	SCREW	1	
1	VKM7760	REAR ALUMI CASE	1	(-S)	B2	VHD2067	SCREW	1	
1	VKM7768	REAR ALUMI CASE	1	(-D)	B3	VHD2067	SCREW	1	
1	VKM7769	REAR ALUMI CASE	1	(-G)	B4	VHD2067	SCREW	1	
2	VMP9267	LENS PLATE	1		B5	VHD2075	SCREW	1	
3	VQL1Y51	BATT DOOR CAUTION LABEL	1	EB,EE,EF,EG,EP,GC,GJ,GN, SG,GH,GT,P,PU	B6	VHD2075	SCREW	1	
3	VQL1Y53	BATT DOOR CAUTION LABEL	1	GK	B7	VHD2075	SCREW	1	
3	VQL1Y52	BATT DOOR CAUTION LABEL	1	PC	B8	VHD2075	SCREW	1	
4	VXW1029	LENS UNIT	1		B9	VHD2076	SCREW	1	
5	VYK3H57	REAR CASE (1)	1		B10	VHD2076	SCREW	1	
7	VMP9316	REAR FPC PLATE	1		B11	VHD1909	SCREW	1	
8	VYK3E16	LCD ASSY	1		B12	VHD1909	SCREW	1	
9	VYK3H61	MODE DIAL (1)	1		B13	VHD1909	SCREW	1	
12	VMP9328	MODE DIAL PIECE	1		B14	VHD1909	SCREW	1	
13	VEP50034A	REAR OPERATION P.C.B.	1	(RTL) E.S.D.	B15	VHD1909	SCREW	1	
14	VGQOE07	MODE DIAL ARM	1		B16	VHD1909	SCREW	1	
15	VGUOD92	REAR BUTTON DISPLAY	1		B17	VHD1909	SCREW	1	
16	VGUOD93	REAR BUTTON CENTER	1		B18	VHD1909	SCREW	1	
17	VGUOD94	REAR BUTTON CROSS	1		B19	VHD1909	SCREW	1	
18	VGUOD95	REAR BUTTON PLAY	1		B20	VHD1909	SCREW	1	
19	VGUOD96	REAR BUTTON REC	1		B21	VHD1909	SCREW	1	
20	VGUOE31	REAR BUTTON Q.MENU	1		B22	VHD1909	SCREW	1	
22	VYK3H58	FRONT CASE (1)	1	(-A)	B23	VHD1909	SCREW	1	
22	VYK3H56	FRONT CASE (1)	1	(-S)	B24	VHD1886	SCREW	1	
22	VYK3H59	FRONT CASE (1)	1	(-D)	B25	VHD1694	SCREW	1	
22	VYK3H60	FRONT CASE (1)	1	(-G)	B26	VHD1681	SCREW	1	
23	L0AA01A00032	SPEAKER	1		B27	VHD1681	SCREW	1	
24	VEP56072B	MAIN P.C.B.	1	(RTL) E.S.D. EB,EF,EG,EP	B28	XQN16+BJ4FN	SCREW	1	
24	VEP56072A	MAIN P.C.B.	1	(RTL) E.S.D. EE,GC,GJ,GN, SG,GH,GK,GT,P,PC,PU	B29	VHD2117	SCREW	1	
25	VGQOC16	ZOOM SLIDE LEVER	1		B30	VHD2117	SCREW	1	
26	VGQOF67	PCB SPECER	1		B31	VHD2085	SCREW	1	
27	VGUOD87	SHUTTER BUTTON	1		B32	VHD2078	SCREW	1	
28	VGUOD88	POWER BUTTON	1		B33	VHD2074	SCREW	1	
30	VWJ2075	FPC	1		B34	VHD2077	SCREW	1	
31	VGQOC17	BATTERY CASE	1		B35	VHD2077	SCREW	1	
32	VGQOC32	TOP BARRIER TAPE	1		B36	VHD1909	SCREW	1	
33	VGQOD32	BATT DETECT LEVER	1		B37	VHD1909	SCREW	1	
34	VGUOD86	BATT LOCK KNOB	1		B38	VHD1909	SCREW	1	
35	VMB4094	BATTERY OUT SPRING	1		B39	VHD1909	SCREW	1	
36	VMB4226	BATT LOCK SPRING	1		B40	VHD1909	SCREW	1	
37	VMB4240	BATT DETECT SPRING	1		B41	VHD1909	SCREW	1	
38	VMC2074	FL EARTH PLATE	1		B42	XQN16+BJ4FN	SCREW	1	
39	VMP9269	BATT LOCK PLATE	1		B43	XQN16+BJ4FN	SCREW	1	
41	VEKON46	FLASH U	1		B44	XQN16+BJ4FN	SCREW	1	
42	VEP58075A	FLASH P.C.B.	1	(RTL) E.S.D.	B45	XQN16+BJ4FN	SCREW	1	
43	VMB4253	CONDENSER EARTH SPRING	1		B46	XQN16+BJ4FN	SCREW	1	
44	VGUOD90	JACK DOOR KNOB	1		B47	VHD2074	SCREW	1	
46	VMB4227	BATT DOOR KNOB SPRING	1		B48	VHD2078	SCREW	1	
47	VQL1V63	JACK DOOR LOCK LABEL	1		B49	VHD1681	SCREW	1	
49	VGQOC15	ZOOM SLIDE PIECE	1		B50	VHD2076	SCREW	1	
50	VGUOD85	ZOOM KNOB	1		B51	XQN16+BJ4FN	SCREW	1	
51	VKM7761	TOP ORNAMENT	1	(DMC-FT1)	P	VUMG1863	WATERPROOF PACKING KIT	1	(Including Ref No.from "P-1 upto "P-8")
51	VKM7956	TOP ORNAMENT	1	(DMC-TS1)	P-1	-----	SCREW O RING	1	(Included in VUMG1863)
52	VMB4230	BATT DOOR SPRING	1		P-2	-----	JACK DOOR BONDING ASSY	1	(Included in VUMG1863)
54	VGQOC31	BATT DOOR LOCK LABEL	1		P-3	-----	BATT DOOR PACKING	1	(Included in VUMG1863)
55	VGUOD89	BATT DOOR KNOB	1		P-4	-----	SCREW O RING	1	(Included in VUMG1863)
56	VKF4532	BATT DOOR	1	(-A)	P-5	-----	TOP BUTTON PACKING	1	(Included in VUMG1863)
56	VKF4443	BATT DOOR	1	(-S)	P-6	-----	CASE O-RING	1	(Included in VUMG1863)
56	VKF4445	BATT DOOR	1	(-D)	P-7	-----	MODE DIAL O-RING	1	(Included in VUMG1863)
56	VKF4446	BATT DOOR	1	(-G)	P-8	-----	REAR BUTTON PACKING	1	(Included in VUMG1863)
58	VQL1V65	BATTERY LABEL	1						
59	VYK3B57	BATT DOOR PLATE U	1						
60	VEP50033A	TOP P.C.B.	1	(RTL) E.S.D.					
61	VMP9270	TOP FPC PLATE	1						
62	VMB4225	ZOOM SPRING	1						
63	VMB4225	ZOOM SPRING	1						
△ 64	ML-421S/ZTK	BUTTON BATTERY	1	(Enagyl)(B6402)					
65	F2A2F9000003	CAPACITOR	1	(C8001)					
66	VGQOF41	EMC DPR SHEET	1						
67	VGQOF66	BARRIER SHEET	1						
70	VMC2077	TOP EARTH PLATE	1						
71	VGQOF65	LENS BARRIER SHEET	1						
72	VGQOF42	EMC BUSTERRAID SHEET	1						

DMC-FT1EB/EE/EF/EG/EP/GC/GJ/GN/SG, TS1GH/GK/GT/P/PC/PU

Ref.No.	Part No.	Part Name & Description	Pcs	Remarks
100	VFP1317	CAMERA BAG	1	
102	VFF0448-S	CD-ROM (SOFT)	1	EB,EE,EF,EG,EP,GC,GJ,GN, SG,GH,GT,P,PC,PU
102	VFF0449-S	CD-ROM (SOFT)	1	GK
△ 103	DE-A60AA	BATTERY CHARGER	1	EB,EF,EG,EP,GN
△ 103	DE-A60BA	BATTERY CHARGER	1	EE,GC,GJ,GH,GK
△ 103	DE-A60EA	BATTERY CHARGER	1	SG
△ 103	DE-A60CA	BATTERY CHARGER	1	GT
△ 103	DE-A59BA	BATTERY CHARGER	1	P,PC,PU
104	K1HA14AD0001	USB CABLE	1	
105	K1HA14CD0001	AV CABLE	1	
106	VFC4393	HAND STRAP	1	
107	VFF0468	CD-ROM (O/I)	1	EG,EP,SG
107	VFF0469	CD-ROM (O/I)	1	GC,GJ,GH
107	VFF0472	CD-ROM (O/I)	1	PU
108	VGQ0D56	BATTERY CASE	1	
109	VPK3842	PACKING CASE	1	EBA,EFA,EGA,EPA,GCA,GNA
109	VPK3801	PACKING CASE	1	EBS,EES,EGS,EPG,GCS,GJS, GNS,SGS
109	VPK3806	PACKING CASE	1	EED,EFD,EGD,EPD,GCD,GJD, GND,SGD
109	VPK3811	PACKING CASE	1	EEG,EEG,EGG,EPG,GCG,GJG, GNG,SGG
109	VPK3807	PACKING CASE	1	GHD,GTD,PUD
109	VPK3812	PACKING CASE	1	GHG,GTG,PUG
109	VPK3802	PACKING CASE	1	GHS,PUS
109	VPK3808	PACKING CASE	1	GKD
109	VPK3813	PACKING CASE	1	GKG
109	VPK3803	PACKING CASE	1	GKS
109	VPK3805	PACKING CASE	1	PD,PCD
109	VPK3810	PACKING CASE	1	PG,PCG
109	VPK3800	PACKING CASE	1	PS,PCS
109	VPK3841	PACKING CASE	1	PCA
109	VPK3843	PACKING CASE	1	PUA
110	VPN6810	CUSHION	1	
111	VFP1294	BAG, POLYETHYLENE	1	
△ 112	VQT1Z56	OPERATING INSTRUCTIONS (ENGLISH)	1	EB
△ 112	VQT1Z57	OPERATING INSTRUCTIONS (RUSSIAN)	1	EE
△ 112	VQT1Z58	OPERATING INSTRUCTIONS (UKRAINIAN)	1	EE
△ 112	VQT1Z55	OPERATING INSTRUCTIONS (FRENCH)	1	EF
△ 112	VQT1Z66	OPERATING INSTRUCTIONS (ENGLISH)	1	GN
△ 112	VQT1Z65	OPERATING INSTRUCTIONS (CHINESE(SIMPLIFIED))	1	GK
△ 112	VQT1Z64	OPERATING INSTRUCTIONS (CHINESE(TRADITIONAL))	1	GT
△ 112	VQT1Z45	OPERATING INSTRUCTIONS (ENGLISH)	1	P,PC
△ 112	VQT1Z46	OPERATING INSTRUCTIONS (SPANISH)	1	P
△ 112	VQT1Z47	OPERATING INSTRUCTIONS (CANADIAN FRENCH)	1	PC
△ 113	VQT1Z49	BASIC O/I (GERMAN/FRENCH)	1	EG
△ 113	VQT1Z50	BASIC O/I (ITALIAN/DUTCH)	1	EG
△ 113	VQT1Z51	BASIC O/I (SPANISH/PORTUGUESE)	1	EG
△ 113	VQT1Z52	BASIC O/I (SWEDISH/DANISH)	1	EP
△ 113	VQT1Z53	BASIC O/I (POLISH/CZECH)	1	EP
△ 113	VQT1Z54	BASIC O/I (HUNGARIAN/FINISH)	1	EP
△ 113	VQT1Z59	BASIC O/I (ENGLISH/ CHINESE(TRADITIONAL))	1	GC,GJ,SG,GH
△ 113	VQT1Z60	BASIC O/I (ARABIC/PERSIAN)	1	GC
△ 113	VQT1Z48	BASIC O/I (SPANISH/PORTUGUESE)	1	PU
△ 114	VQT1Z74	O/I SUPPLIED SOFTWARE (ENGLISH)	1	EB,GN

Ref.No.	Part No.	Part Name & Description	Pcs	Remarks
△ 114	VQT1Z75	O/I SUPPLIED SOFTWARE (RUSSIAN/UKRAINIAN)	1	EE
△ 114	VQT1Z73	O/I SUPPLIED SOFTWARE (FRENCH)	1	EF
△ 114	VQT1Z71	O/I SUPPLIED SOFTWARE (GERMAN/FRENCH/ITALIAN/ DUTCH/SPANISH/ PORTUGUESE)	1	EG
△ 114	VQT1Z72	O/I SUPPLIED SOFTWARE (FINNISH/SWEDISH/DANISH/ POLISH/CZECH/HUNGARIAN)	1	EP
△ 114	VQT1Z76	O/I SUPPLIED SOFTWARE (ENGLISH/ CHINESE(TRADITIONAL)/ ARABIC/PERSIAN)	1	GC,GJ,SG,GH
△ 114	VQT1Z79	O/I SUPPLIED SOFTWARE (CHINESE(SIMPLIFIED))	1	GK
△ 114	VQT1Z78	O/I SUPPLIED SOFTWARE (CHINESE(TRADITIONAL))	1	GT
△ 114	VQT1Z69	O/I SUPPLIED SOFTWARE (ENGLISH/CANADIAN FRENCH)	1	P,PC
△ 114	VQT1Z70	O/I SUPPLIED SOFTWARE (SPANISH/PORTUGUESE)	1	PU
115	VFC4364	CLEANING BRUSH	1	
△ 116	----	BATTERY PACK	1	EB,EE,EF,EG,EP,GC,GJ,GN, SG,GH,GT,PU
△ 116	----	BATTERY PACK	1	GK
△ 116	----	BATTERY PACK	1	P,PC
117	VPN6666	PAD	1	EB,GC,GH
117	VPN6664	PAD	1	EE,EF,EG,EP,GJ, GN,SG,GK,GT,PU
△ 118	K2CT3CA00004	AC CORD W/PLUG	1	EB,GC,GH
△ 118	K2CQ2CA00006	AC CORD W/PLUG	1	EE,EF,EG,EP,GC
△ 118	K2CP2Y00001	AC CORD W/PLUG	1	GJ
△ 118	K2CJ2DA00008	AC CORD W/PLUG	1	GN
△ 118	K2CA2CA00019	AC CORD W/PLUG	1	SG
△ 118	K2CA2CA00020	AC CORD W/PLUG	1	GK
△ 118	K2CA2CA00027	AC CORD W/PLUG	1	GT
119	VQL1L48-6	OPERATING LABEL	1	PC
119	VQL1G34-6	OPERATING LABEL	1	GT

S7. Exploded View

S7.1. Frame and Casing Section

From Ref No. "P-1" to "P-8" are supplied as a "waterproof packing kit" (Part No. VUMG1863)

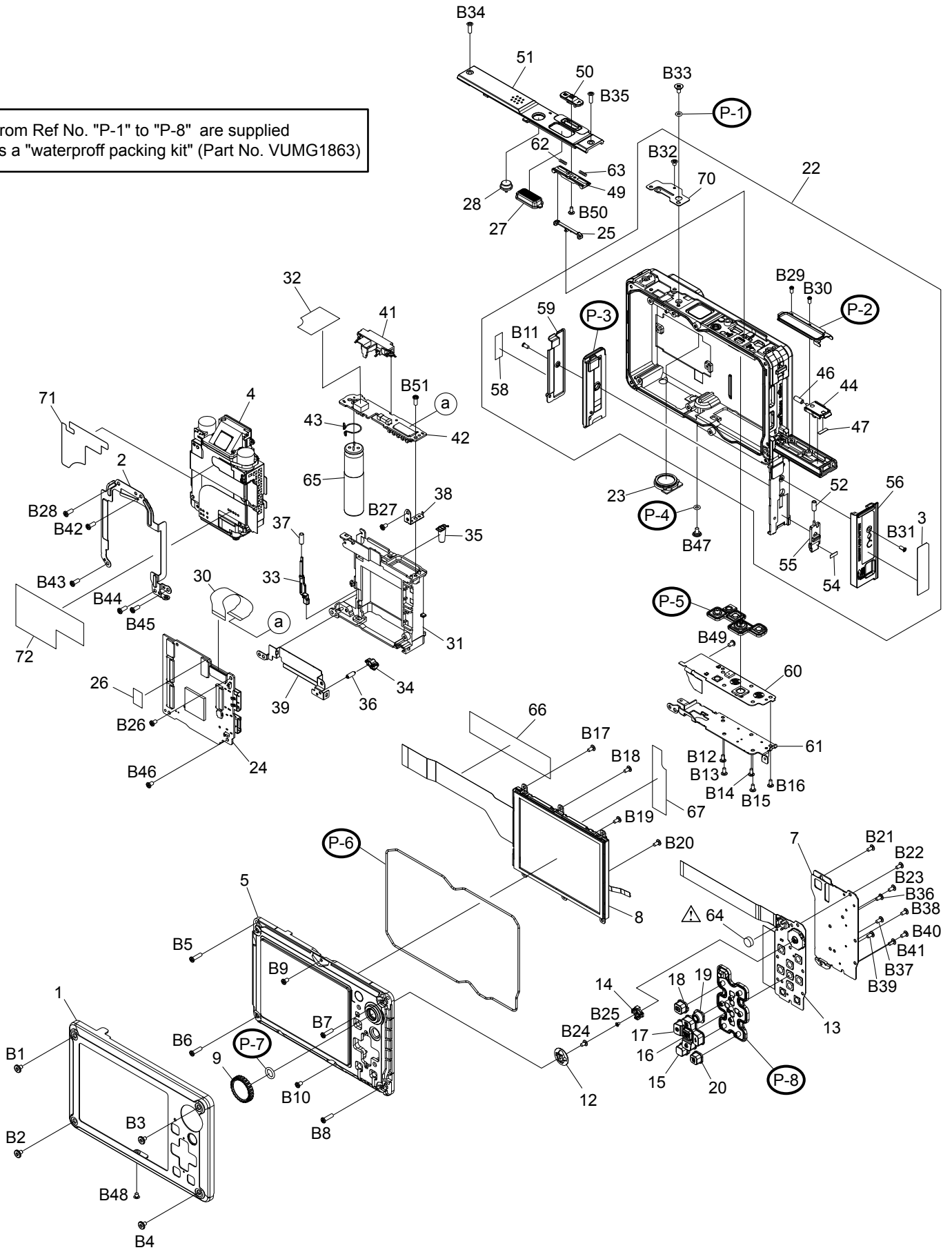

S7.2. Packing Parts and Accessories Section

