

# Service Manual

Digital Camera

LUMIX

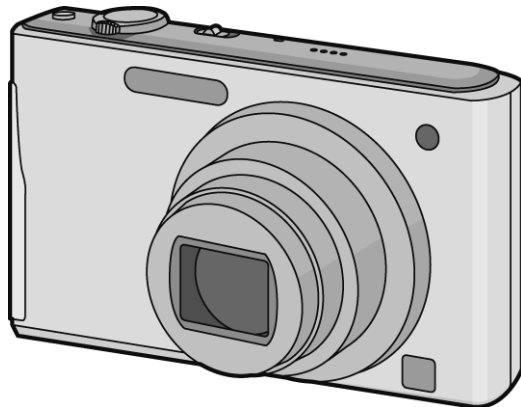

Model No. **DMC-FS35EB**

**DMC-FS35EE**

**DMC-FS35EF**

**DMC-FS35EG**

**DMC-FS35EP**

**DMC-FH25P**

**DMC-FH25PC**

**DMC-FH25PR**

**DMC-FH25PU**

**DMC-FH25GA**

**DMC-FH25GC**

**DMC-FH25GF**

**DMC-FH25GH**

**DMC-FH25GK**

**DMC-FH25GN**

**DMC-FH25GT**

**DMC-FH24P**

Vol. 1

**Panasonic**<sup>®</sup>

© Panasonic Corporation 2011 Unauthorized copying and distribution is a violation of law.

Colour  
 [DMC-FS35]  
 (S).....Silver Type (except EF)  
 (K).....Black Type  
 (R).....Red Type (except EE)  
 (A).....Blue Type (except EF)  
 (V).....Violet Type (except EE/EF)

[DMC-FH25]  
 (S).....Silver Type (except PC/PR/GT)  
 (K).....Black Type  
 (R).....Red Type (except PR/GT)  
 (A).....Blue Type (only P/PC/PU/GK/GN)  
 (V).....Violet Type (only P/PC/PR/PU/GT)  
 [DMC-FH24]  
 (K).....Black Type

**⚠ WARNING**

This service information is designed for experienced repair technicians only and is not designed for use by the general public. It does not contain warnings or cautions to advise non-technical individuals of potential dangers in attempting to service a product. Products powered by electricity should be serviced or repaired only by experienced professional technicians. Any attempt to service or repair the product or products dealt with in this service information by anyone else could result in serious injury or death.

# TABLE OF CONTENTS

	PAGE		PAGE
<b>1 Safety Precautions</b> .....	<b>3</b>	<b>8 Disassembly and Assembly Instructions</b> .....	<b>22</b>
1.1. General Guidelines .....	3	8.1. Disassembly Flow Chart .....	22
1.2. Leakage Current Cold Check .....	3	8.2. PCB Location .....	22
1.3. Leakage Current Hot Check (See Figure 1.) .....	3	8.3. Disassembly Procedure .....	23
1.4. How to Discharge the E.Capacitor on Flash Top P.C.B. ....	4	8.4. Lens Disassembly Procedure .....	28
<b>2 Warning</b> .....	<b>5</b>	8.5. Assembly Procedure for the Lens .....	32
2.1. Prevention of Electrostatic Discharge (ESD) to Electrostatically Sensitive (ES) Devices .....	5	8.6. Removal of the CCD Unit .....	38
2.2. How to Recycle the Lithium Ion Battery (U.S. Only) .....	5	8.7. Removal of the Focus Motor .....	38
2.3. Caution for AC Cord(For EB/GC/GH) .....	6	8.8. The Application of Grease Method .....	38
2.4. How to Replace the Lithium Battery .....	7	<b>9 Measurements and Adjustments</b> .....	<b>39</b>
<b>3 Service Navigation</b> .....	<b>8</b>	9.1. Introduction .....	39
3.1. Introduction .....	8	9.2. Before Disassembling the unit .....	39
3.2. General Description About Lead Free Solder (PbF) .....	8	9.3. Details of Electrical Adjustment .....	41
3.3. Important Notice 1:(Other than U.S.A. and Canadian Market) .....	8	9.4. After Adjustment .....	45
3.4. How to Define the Model Suffix (NTSC or PAL model) .....	9	<b>10 Maintenance</b> .....	<b>46</b>
<b>4 Specifications</b> .....	<b>13</b>	10.1. Cleaning Lens and LCD Panel .....	46
<b>5 Location of Controls and Components</b> .....	<b>14</b>		
<b>6 Service Mode</b> .....	<b>16</b>		
6.1. Error Code Memory Function .....	16		
6.2. ICS (Indication of additional Camera Settings when picture was taken) function .....	18		
<b>7 Service Fixture &amp; Tools</b> .....	<b>20</b>		
7.1. Service Fixture and Tools .....	20		
7.2. When Replacing the Main P.C.B. ....	21		
7.3. Service Position .....	21		

# 1 Safety Precautions

## 1.1. General Guidelines

### 1. IMPORTANT SAFETY NOTICE

There are special components used in this equipment which are important for safety. These parts are marked by

 in the Schematic Diagrams, Circuit Board Layout, Exploded Views and Replacement Parts List. It is essential that these critical parts should be replaced with manufacturer's specified parts to prevent X-RADIATION, shock, fire, or other hazards. Do not modify the original design without permission of manufacturer.

2. An Isolation Transformer should always be used during the servicing of AC Adaptor whose chassis is not isolated from the AC power line. Use a transformer of adequate power rating as this protects the technician from accidents resulting in personal injury from electrical shocks. It will also protect AC Adaptor from being damaged by accidental shorting that may occur during servicing.
3. When servicing, observe the original lead dress. If a short circuit is found, replace all parts which have been overheated or damaged by the short circuit.
4. After servicing, see to it that all the protective devices such as insulation barriers, insulation papers shields are properly installed.
5. After servicing, make the following leakage current checks to prevent the customer from being exposed to shock hazards.

## 1.2. Leakage Current Cold Check

1. Unplug the AC cord and connect a jumper between the two prongs on the plug.
2. Measure the resistance value, with an ohmmeter, between the jumpered AC plug and each exposed metallic cabinet part on the equipment such as screwheads, connectors, control shafts, etc. When the exposed metallic part has a return path to the chassis, the reading should be between  $1\text{ M}\Omega$  and  $5.2\text{ M}\Omega$ . When the exposed metal does not have a return path to the chassis, the reading must be infinity.

## 1.3. Leakage Current Hot Check (See Figure 1.)

1. Plug the AC cord directly into the AC outlet. Do not use an isolation transformer for this check.
2. Connect a  $1.5\text{ k}\Omega$ ,  $10\text{ W}$  resistor, in parallel with a  $0.15\text{ }\mu\text{F}$  capacitor, between each exposed metallic part on the set and a good earth ground, as shown in Figure 1.
3. Use an AC voltmeter, with  $1\text{ k}\Omega/\text{V}$  or more sensitivity, to measure the potential across the resistor.
4. Check each exposed metallic part, and measure the voltage at each point.
5. Reverse the AC plug in the AC outlet and repeat each of the above measurements.
6. The potential at any point should not exceed  $0.75\text{ V RMS}$ . A leakage current tester (Simpson Model 229 or equivalent) may be used to make the hot checks, leakage current must not exceed  $1/2\text{ mA}$ . In case a measurement is outside of the limits specified, there is a possibility of a shock hazard, and the equipment should be repaired and rechecked before it is returned to the customer.

Hot-Check Circuit

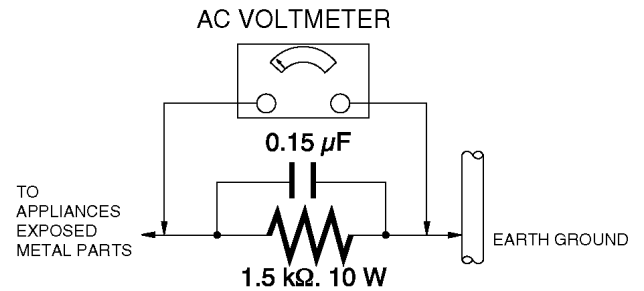

Figure. 1

## 1.4. How to Discharge the E.Capacitor on Flash Top P.C.B.

### CAUTION:

1. Be sure to discharge the E.capacitor on FLASH TOP P.C.B..
2. Be careful of the high voltage circuit on FLASH TOP P.C.B. when servicing.

### [Discharging Procedure]

1. Refer to the disassemble procedure and remove the necessary parts/unit.
2. Install the insulation tube onto the lead part of resistor (ERG5SJ102:1k $\Omega$  /5W).  
(An equivalent type of resistor may be used.)
3. Place a resistor between both terminals of E.capacitor on the FLASH Top P.C.B. for approx. 5 seconds.
4. After discharging, confirm that the E.capacitor voltage is lower than 10V using a voltmeter.

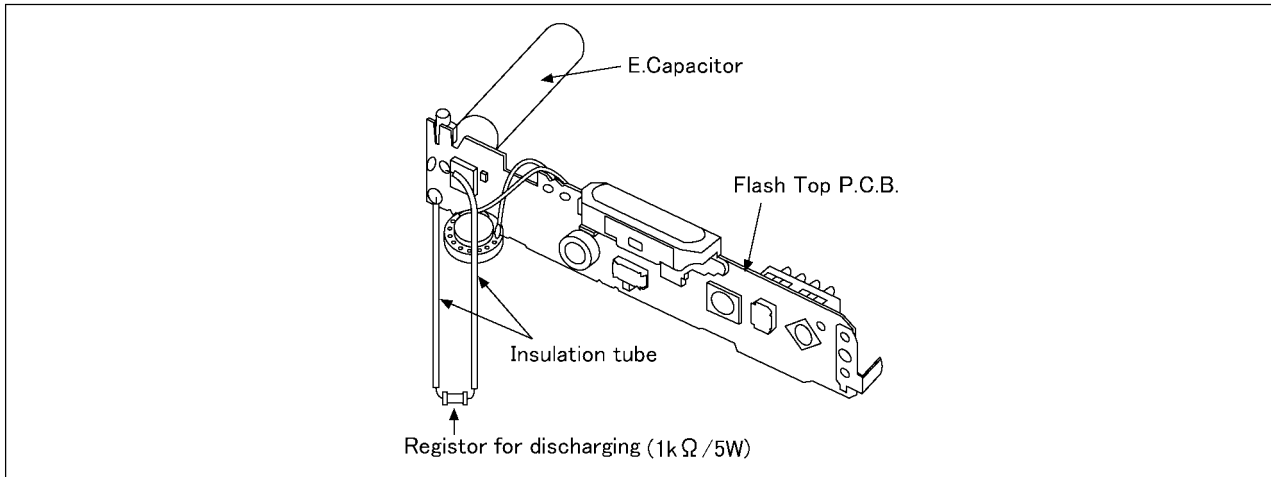

Fig. F1

## 2 Warning

### 2.1. Prevention of Electrostatic Discharge (ESD) to Electrostatically Sensitive (ES) Devices

Some semiconductor (solid state) devices can be damaged easily by static electricity. Such components commonly are called Electrostatically Sensitive (ES) Devices.

Examples of typical ES devices are CCD image sensor, IC (integrated circuits) and some field-effect transistors and semiconductor "chip" components.

The following techniques should be used to help reduce the incidence of component damage caused by electrostatic discharge (ESD).

1. Immediately before handling any semiconductor component or semiconductor-equipped assembly, drain off any ESD on your body by touching a known earth ground. Alternatively, obtain and wear a commercially available discharging ESD wrist strap, which should be removed for potential shock reasons prior to applying power to the unit under test.
2. After removing an electrical assembly equipped with ES devices, place the assembly on a conductive surface such as aluminum foil, to prevent electrostatic charge buildup or exposure of the assembly.
3. Use only a grounded-tip soldering iron to solder or unsolder ES devices.
4. Use only an antistatic solder removal device. Some solder removal devices not classified as "antistatic (ESD protected)" can generate electrical charge sufficient to damage ES devices.
5. Do not use freon-propelled chemicals. These can generate electrical charges sufficient to damage ES devices.
6. Do not remove a replacement ES device from its protective package until immediately before you are ready to install it. (Most replacement ES devices are packaged with leads electrically shorted together by conductive foam, aluminum foil or comparable conductive material).
7. Immediately before removing the protective material from the leads of a replacement ES device, touch the protective material to the chassis or circuit assembly into which the device will be installed.

**CAUTION :**

Be sure no power is applied to the chassis or circuit, and observe all other safety precautions.

8. Minimize bodily motions when handling unpackaged replacement ES devices. (Otherwise harmless motion such as the brushing together of your clothes fabric or the lifting of your foot from a carpeted floor can generate static electricity (ESD) sufficient to damage an ES device).

### 2.2. How to Recycle the Lithium Ion Battery (U.S. Only)

**ENGLISH**



A lithium ion battery that is recyclable powers the product you have purchased. Please call 1-800-8-BATTERY for information on how to recycle this battery.

**FRANÇAIS**



L'appareil que vous vous êtes procuré est alimenté par une batterie au lithium-ion recyclable. Pour des renseignements sur le recyclage de la batterie, veuillez composer le 1-800-8-BATTERY.

## 2.3. Caution for AC Cord (For EB/GC/GH)

### 2.3.1. Information for Your Safety

#### IMPORTANT

Your attention is drawn to the fact that recording of pre-recorded tapes or discs or other published or broadcast material may infringe copyright laws.

#### WARNING

To reduce the risk of fire or shock hazard, do not expose this equipment to rain or moisture.

#### CAUTION

To reduce the risk of fire or shock hazard and annoying interference, use the recommended accessories only.

#### FOR YOUR SAFETY

##### DO NOT REMOVE THE OUTER COVER

To prevent electric shock, do not remove the cover. No user serviceable parts inside. Refer servicing to qualified service personnel.

### 2.3.2. Caution for AC Mains Lead

For your safety, please read the following text carefully.

This appliance is supplied with a moulded three-pin mains plug for your safety and convenience.

A 5-ampere fuse is fitted in this plug.

Should the fuse need to be replaced please ensure that the replacement fuse has a rating of 5 amperes and it is approved by ASTA or BSI to BS1362

Check for the ASTA mark or the BSI mark on the body of the fuse.



If the plug contains a removable fuse cover you must ensure that it is refitted when the fuse is replaced.

If you lose the fuse cover, the plug must not be used until a replacement cover is obtained.

A replacement fuse cover can be purchased from your local Panasonic Dealer.

If the fitted moulded plug is unsuitable for the socket outlet in your home then the fuse should be removed and the plug cut off and disposed of safely.

There is a danger of severe electrical shock if the cut off plug is inserted into any 13-ampere socket.

If a new plug is to be fitted please observe the wiring code as shown below.

If in any doubt, please consult a qualified electrician.

### 2.3.2.1. Important

The wires in this mains lead are coloured in accordance with the following code:

Blue	Neutral
Brown	Live

As the colours of the wires in the mains lead of this appliance may not correspond with the coloured markings identifying the terminals in your plug, proceed as follows:

The wire which is coloured BLUE must be connected to the terminal in the plug which is marked with the letter N or coloured BLACK.

The wire which is coloured BROWN must be connected to the terminal in the plug which is marked with the letter L or coloured RED.

Under no circumstances should either of these wires be connected to the earth terminal of the three pin plug, marked with the letter E or the Earth Symbol.



### 2.3.2.2. Before Use

Remove the Connector Cover as follows.

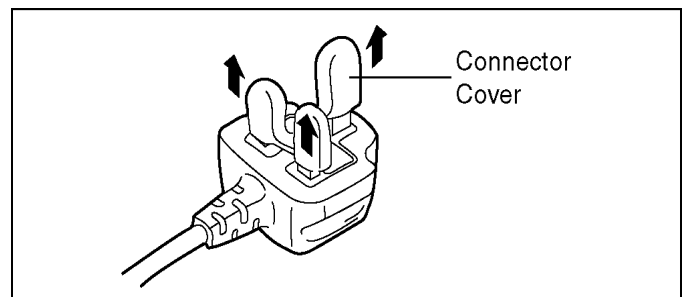

### 2.3.2.3. How to Replace the Fuse

1. Remove the Fuse Cover with a screwdriver.

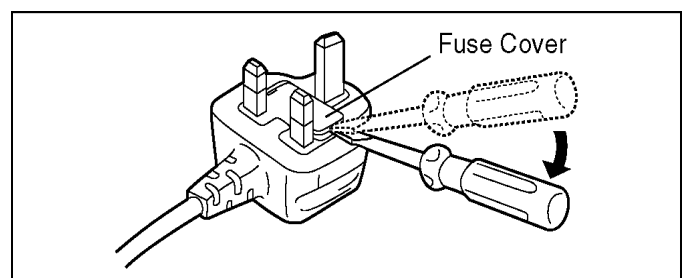

2. Replace the fuse and attach the Fuse cover.

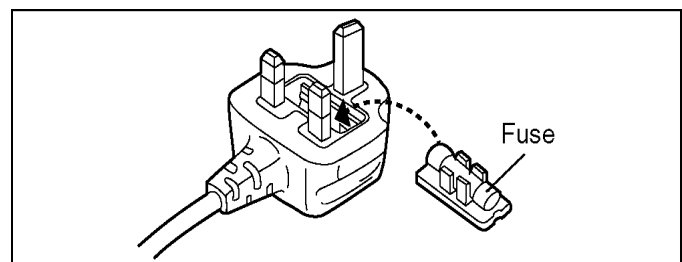

## 2.4. How to Replace the Lithium Battery

### 2.4.1. Replacement Procedure

1. Remove the MAIN P.C.B.. (Refer to Disassembly Procedures.)
2. Unsolder the each soldering point of electric lead terminal for Lithium battery (Ref. No. "B9101" at component side of MAIN P.C.B.) and remove the Lithium battery together with electric lead terminal. Then replace it into new one.

**NOTE:**

The Type No. ML421 includes electric lead terminals.

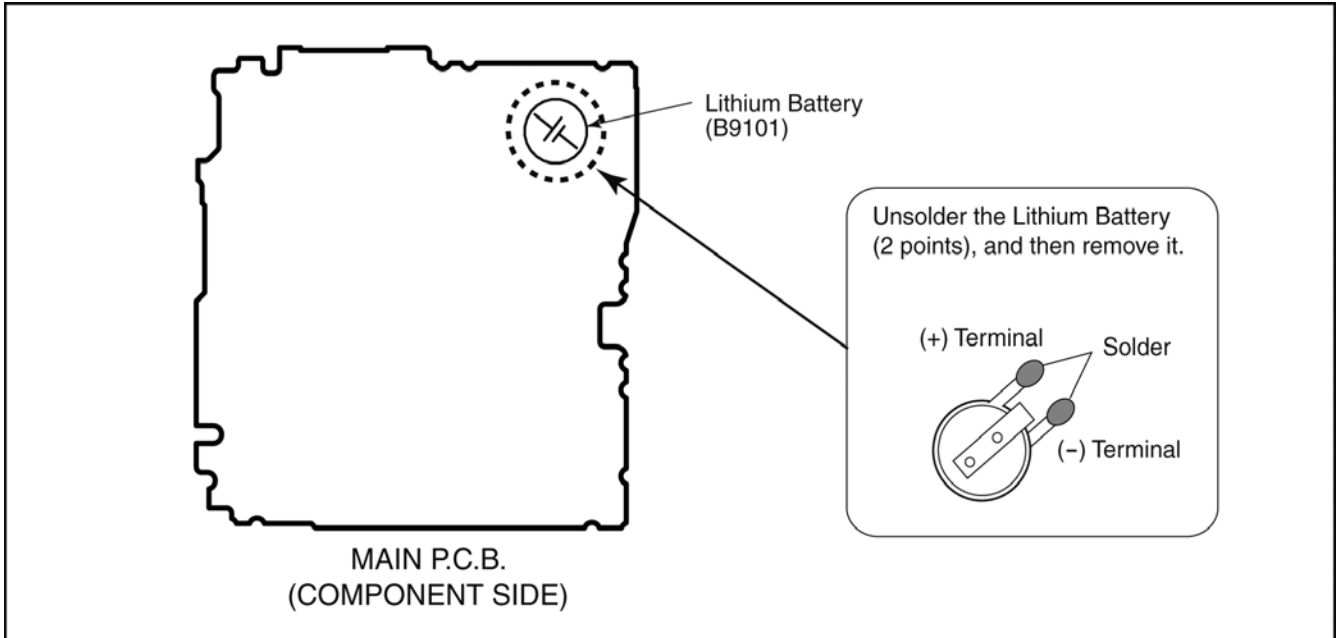

**NOTE:**

This Lithium battery is a critical component.

(Type No.: ML421 **Manufactured by Energy Company, Panasonic Corporation.**)

It must never be subjected to excessive heat or discharge.

It must therefore only be fitted in requirement designed specifically for its use.

Replacement batteries must be of same type and manufacture.

They must be fitted in the same manner and location as the original battery, with the correct polarity contacts observed.

Do not attempt to re-charge the old battery or re-use it for any other purpose.

It should be disposed of in waste products destined for burial rather than incineration.

**(For English)**

### **CAUTION**

Danger of explosion if battery is incorrectly replaced.

Replace only with the same or equivalent type recommended by the manufacturer.

Dispose of used batteries according to the manufacturer's instructions.

**(For German)**

### **ACHTUNG**

Explosionsgefahr bei falschem Anbringen der Batterie. Ersetzen Sie nur mit einem äquivalentem vom Hersteller empfohlenem Typ.

Behandeln Sie gebrauchte Batterien nach den Anweisungen des Herstellers.

**(For French)**

### **MISE EN GARDE**

Une batterie de remplacement inappropriée peut exploser. Ne remplacez qu'avec une batterie identique ou d'un type recommandé par le fabricant. L'élimination des batteries usées doit être faite conformément aux instructions du fabricant.

**NOTE:**

Above caution is applicable for a battery pack which is for DMC-FS35, FH25, FH24 series, as well.

## 3 Service Navigation

### 3.1. Introduction

This service manual contains technical information, which allow service personnel's to understand and service this model.

Please place orders using the parts list and not the drawing reference numbers.

If the circuit is changed or modified, the information will be followed by service manual to be controlled with original service manual.

### 3.2. General Description About Lead Free Solder (PbF)

The lead free solder has been used in the mounting process of all electrical components on the printed circuit boards used for this equipment in considering the globally environmental conservation.

The normal solder is the alloy of tin (Sn) and lead (Pb). On the other hand, the lead free solder is the alloy mainly consists of tin (Sn), silver (Ag) and Copper (Cu), and the melting point of the lead free solder is higher approx.30°C (86°F) more than that of the normal solder.

#### Distinction of P.C.B. Lead Free Solder being used

The letter of "PbF" is printed either foil side or components side on the P.C.B. using the lead free solder.(See right figure)
--

PbF
-----

#### Service caution for repair work using Lead Free Solder (PbF)

- The lead free solder has to be used when repairing the equipment for which the lead free solder is used.  
(Definition: The letter of "PbF" is printed on the P.C.B. using the lead free solder.)
- To put lead free solder, it should be well molten and mixed with the original lead free solder.
- Remove the remaining lead free solder on the P.C.B. cleanly for soldering of the new IC.
- Since the melting point of the lead free solder is higher than that of the normal lead solder, it takes the longer time to melt the lead free solder.
- Use the soldering iron (more than 70W) equipped with the temperature control after setting the temperature at 350±30°C (662±86°F).

#### Recommended Lead Free Solder (Service Parts Route.)

- The following 3 types of lead free solder are available through the service parts route.
  - RFKZ03D01KS----- (0.3mm 100g Reel)
  - RFKZ06D01KS----- (0.6mm 100g Reel)
  - RFKZ10D01KS----- (1.0mm 100g Reel)

#### Note

\* Ingredient: tin (Sn) 96.5%, silver (Ag) 3.0%, Copper (Cu) 0.5%, Cobalt (Co) / Germanium (Ge) 0.1 to 0.3%

### 3.3. Important Notice 1:(Other than U.S.A. and Canadian Market)

1. The service manual does not contain the following information because of issues servicing to component level without necessary equipment/facilities.
  - a. Schematic diagram, Block Diagram and P.C.B. layout of MAIN P.C.B. and SUB P.C.B..
  - b. Parts list for individual parts for MAIN P.C.B. and SUB P.C.B..When a part replacement is required for repairing MAIN P.C.B. and/or SUB P.C.B., replace as an assembled parts. (MAIN P.C.B./SUB P.C.B.)
2. The following category is/are recycle module part. please send it/them to Central Repair Center.
  - MAIN P.C.B. (VEP56126C): Excluding replacement of Lithium Battery
  - SUB P.C.B. (VEP59094A)



### 3.4. How to Define the Model Suffix (NTSC or PAL model)







There are eight kinds of DMC-FS35, FH25, FH24, regardless of the colours.

- a) DMC-FH24P
- b) DMC-FH25P/PC
- c) DMC-FS35EB/EF/EG/EP
- d) DMC-FS35EE
- e) DMC-FH25GT
- f) DMC-FH25GK
- g) DMC-FH25GN
- h) DMC-FH25PR/PU/GA/GC/GF/GH

What is the difference is that the "INITIAL SETTINGS" data which is stored in Flash-ROM mounted on MAIN P.C.B..

#### 3.4.1. Defining methods:

To define the model suffix to be serviced, refer to the nameplate which is putted on the bottom side of the Unit.

<p><b>a) DMC-FH24P</b> The nameplate for this model shows the following Safety registration mark.</p> 
<p><b>b) DMC-FH25P/PC</b> The nameplate for these models show the following Safety registration mark.</p> 
<p><b>c) DMC-FS35EB/EF/EG/EP</b> The nameplate for these models show the following Safety registration mark.</p> 
<p><b>d) DMC-FS35EE</b> The nameplate for this model shows the following Safety registration mark.</p> 
<p><b>e) DMC-FH25GT</b> The nameplate for this model shows the following Safety registration mark.</p> 
<p><b>f) DMC-FH25GK</b> The nameplate for this model shows the following Safety registration mark.</p> 
<p><b>h) DMC-FH25GN</b> The nameplate for this model shows the following Safety registration mark.</p> 
<p><b>i) DMC-FH25PR/PU/GA/GC/GF/GH</b> The nameplate for these models do not show any above Safety registration mark.</p>

**NOTE:**

After replacing the MAIN P.C.B., be sure to achieve adjustment.

The service software is available at "TSN Website". To download, click on "Support Information from NWBG/VDBG-AVC".

### 3.4.2. INITIAL SETTINGS:

After replacing the MAIN P.C.B., be sure to perform the initial settings after achieving the adjustment by ordering the following procedure in accordance with model suffix of the unit.

#### 1. IMPORTANT NOTICE:

Before proceeding Initial settings, be sure to read the following CAUTIONS.

### CAUTION 1:(INITIAL SETTINGS)

---AFTER REPLACING THE MAIN P.C.B. ---

\*.The model suffix can be chosen JUST ONE TIME.

\*.Once one of the model suffix has been chosen, the model suffix lists will not be displayed, thus, it can not be changed.

### CAUTION 2:(Stored picture image data in the unit)

This unit employs "Built-in Memory" for picture image data recording. (Approx. 70 MB)

After proceeding "INITIAL SETTINGS", the picture image data stored in the unit is erased.

#### 2. PROCEDURES:

- Precautions: Read the above "CAUTION 1" and "CAUTION 2", carefully.

- Preparation:

- Attach the Battery or AC Adaptor with a DC coupler to the unit.

(Since this unit has built-in memory, it can be performed without inserting SD memory card.)

1. Turn the Power on.

2. Press the [ MODE ] button, and select the [ NORMAL PICTURE ] mode by Cursor buttons, then press the [ MENU/SET ] button.

3. Turn the Power off.

(If the unit is other than [ NORMAL PICTURE ] mode, it does not display the initial settings menu.)

- **Step 1. The temporary cancellation of "INITIAL SETTINGS":**

Set the [ REC ]/[ PLAYBACK ] selector switch to "[ REC ] (Camera mark)".

While pressing "[ UP ] of Cursor button" and [ E.ZOOM ] button simultaneously, turn the Power on.

- **Step 2. The cancellation of "INITIAL SETTINGS":**

Set the [ REC ]/[ PLAYBACK ] selector switch to "[ PLAYBACK ]".

Press "[ UP ] of Cursor button" and [ E.ZOOM ] button simultaneously, then turn the Power off.

The LCD displays the "!" mark before the unit powers down.



- **Step 3. Turn the Power on:**

Set the [ REC ]/[ PLAYBACK ] selector switch to "[ REC ] (Camera mark)", and then turn the Power on.

- **Step 4. Display the INITIAL SETTING:**

While pressing [ MENU/SET ] and "[ RIGHT ] of Cursor buttons" simultaneously, turn the Power off.

The "INITIAL SETTINGS" menu is displayed.

There are two kinds of "INITIAL SETTINGS" menu form as follows:

[CASE 1. After replacing MAIN P.C.B.]

When MAIN P.C.B. has just been replaced, all of the model suffix is displayed as follows. (Five pages in total)

The following table summarizes the model suffix options shown in the five screenshots:

Screenshot	Selected Suffix	Available Suffixes
1 (No "Japan" model)	NONE(JAPAN) FH25	NONE(JAPAN) FH25, P, EG, PU, GD
2 (No "SG" model)	SG FS35	SG FS35, LB, EC, GH, EP
3 (No "GC" model)	GC FH25	GC FH25, GT, GK, EF, EB
4 (No "EN" model)	EN FS35	EN FS35, GF, GM, GA
5 (No "EE" model)	EE FS35	EE FS35, GN, PC, PR, GJ

[CASE 2. Other than "After replacing MAIN P.C.B."]

The following table summarizes the model suffix options shown in the three screenshots for Case 2:

Screenshot	Selected Suffix	Available Suffixes
1 (<Other than "EG/EF/EB/EP" models>)	GC FH25	GC FH25
2 (<Only "EG/EF/EB/EP" models>)	EG FS35	EG FS35, EF, EB, EC, EP
3 (<Only "EG/EF/EB/EP" models>)	EN FS35	EN FS35

• **Step 5. Choose the model suffix in "INITIAL SETTINGS": (Refer to "CAUTION 1")**

**[Caution: After replacing MAIN P.C.B.]**

The model suffix can be chosen, **JUST ONE TIME**.

Once one of the model suffix have been chosen, the model suffix lists will not be displayed, thus, it can not be changed.

Therefore, select the area carefully.

Select the area with pressing "[ UP ] / [ DOWN ] of Cursor buttons".

• **Step 6. Chose the model number in “INITIAL SETTINGS”: (Only for “P” models.)**

**This step is necessary only for “P”.**

Only for model suffix with “P”, there are two kind of model; (DMC-FH25 and DMC-FH24) ,due to difference of sales channel. Therefore, not only model suffix, but also model number (FH25 or FH24) has to be set up in the “INITIAL SETTINGS”. (The “FH25” is displayed as default status.)

When the model number is one of the "DMC-FH24P", change the model number with the following procedure:

Press the [E.ZOOM] button in order to change the indication from "FH25" into "FH24".

(Each time one presses the [E.ZOOM] button, model indication is changed from "FH25" to "FH24" (Toggle switch))

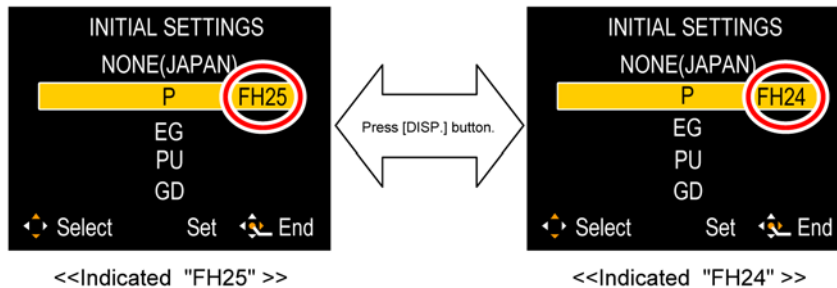

• **Step 7. Set the model suffix in “INITIAL SETTINGS”:**

• Press the “[ RIGHT ] of Cursor buttons”.

• The only set area is displayed, and then press the “[ RIGHT ] of Cursor buttons” after confirmation.

(The unit is powered off automatically.)

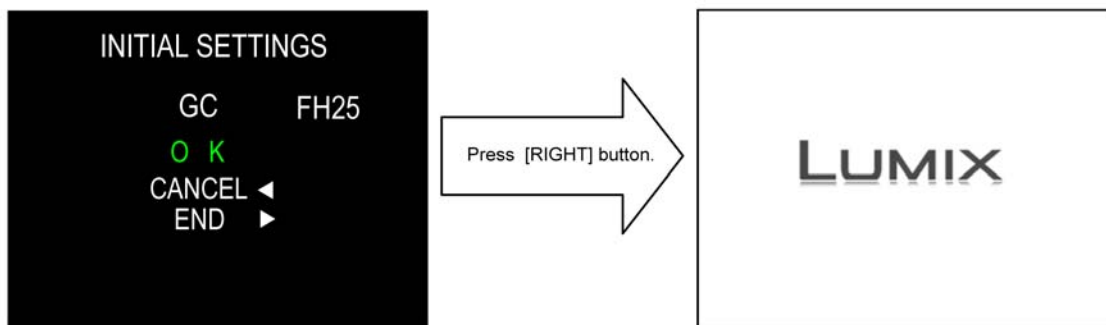

• **Step 8. CONFIRMATION:**

Confirm the display of “PLEASE SET THE CLOCK” in concernd language when the unit is turned on again.

When the unit is connected to PC with USB cable, it is detected as removable media.

(When the “GT” or “GK” model suffix is selected, the display shows “PLEASE SET THE CLOCK” in Chinese.)

1) As for your reference, major default setting condition is as shown in the following table.

• **Default setting (After “INITIAL SETTINGS”)**

	MODEL	VIDEO OUTPUT	LANGUAGE	DATE	REMARKS
a)	DMC-FH25P/FH24P	NTSC	English	Month/Date/Year	
b)	DMC-FS35EG	PAL	English	Date/Month/Year	
c)	DMC-FH25PU	NTSC	Spanish	Month/Date/Year	
d)	DMC-FH25GC	PAL	English	Date/Month/Year	
e)	DMC-FH25GT	NTSC	Chinese (traditional)	Year/Month/Date	
f)	DMC-FH25GK	PAL	Chinese (simplified)	Year/Month/Date	
g)	DMC-FS35EF	PAL	French	Date/Month/Year	
h)	DMC-FS35EB	PAL	English	Date/Month/Year	
i)	DMC-FS35EE	PAL	Russian	Date/Month/Year	
j)	DMC-FH25GN	PAL	English	Date/Month/Year	
k)	DMC-FH25PC	NTSC	English	Month/Date/Year	
l)	DMC-FH25PR	PAL	Spanish	Date/Month/Year	
m)	DMC-FH25GH	PAL	English	Date/Month/Year	
n)	DMC-FS35EP	PAL	English	Date/Month/Year	
o)	DMC-FH25GF	PAL	English	Date/Month/Year	
p)	DMC-FH25GA	PAL	English	Date/Month/Year	

# 4 Specifications

## Digital Camera:

Information for your safety

<b>Power Source:</b>	DC 5.1 V	
<b>Power Consumption:</b>	1.1 W (When recording) 0.7 W (When playing back)	
<b>Camera effective pixels</b>	16,100,000 pixels	
<b>Image sensor</b>	1/2.33" CCD, total pixel number 16,600,000 pixels, Primary color filter	
<b>Lens</b>	Optical 8×zoom, f=5 mm to 40 mm (35 mm film camera equivalent: 28 mm to 224 mm)/F3.3 (Wide) to F5.9 (Tele)	
<b>Digital zoom</b>	Max. 4×	
<b>Extended optical zoom</b>	Max. 18× (When set to 3,000,000 pixels [3M] or less)	
<b>Focus range</b>	Normal	50 cm (1.64 feet) (Wide)/2 m (6.56 feet) (Tele) to ∞
	Macro/ Intelligent auto/ Motion picture	5 cm (0.17 feet) (Wide)/1 m (3.28 feet) (Tele) to ∞
	Scene Mode	There may be differences in the above settings.
<b>Shutter system</b>	Electronic shutter+Mechanical shutter	
<b>Burst recording</b>		
<b>Burst speed</b>	Approx. 1.7 pictures/second	
<b>Number of recordable pictures</b>	Depends on the remaining capacity of the built-in memory/card.	
<b>Hi-speed burst</b>		
<b>Burst speed</b>	Approx. 4 pictures/second [3M (4:3), 2.5M (3:2) or 2M (16:9) is selected as the picture size.]	
<b>Number of recordable pictures</b>	When using the built-in memory: Approx. 15 pictures (immediately after formatting) When using a Card: Max. 100 pictures (differs depending on the type of Card and the recording conditions)	
<b>Shutter speed</b>	8 seconds to 1/1600th of a second [Starry Sky] Mode: 15 seconds, 30 seconds, 60 seconds	
<b>Exposure (AE)</b>	Program AE Exposure compensation (1/3 EV Step, -2 EV to +2 EV)	
<b>Metering mode</b>	Multiple	

<b>LCD monitor</b>	2.7" TFT LCD (4:3) (Approx. 230,000 dots) (field of view ratio about 100%)
<b>Flash range</b>	Approx. 60 cm (1.97 feet) to 5.8 m (19.0 feet) (Wide, [ISO] is set)
<b>Microphone</b>	Monaural
<b>Speaker</b>	Monaural
<b>Recording media</b>	Built-in Memory (Approx. 70 MB)/SD Memory Card/ SDHC Memory Card/SDXC Memory Card
<b>Recording file format</b>	
<b>Still Picture</b>	JPEG (based on "Design rule for Camera File system", based on "Exif 2.3" standard)/DPOF corresponding
<b>Motion pictures</b>	"QuickTime Motion JPEG" (motion pictures with audio)
<b>Interface</b>	
<b>Digital</b>	"USB 2.0" (High Speed)
<b>Analog video/ audio</b>	[for NTSC areas] NTSC [for PAL areas] NTSC/PAL Composite (Switched by menu), Audio line output (monaural)
<b>Terminal</b>	
<b>[AV OUT/ DIGITAL]</b>	Dedicated jack (8 pin)
<b>Dimensions</b> (excluding the projecting parts)	Approx. 99.2 mm (W)×56.5 mm (H)×27.8 mm (D) [3.9"(W)×2.2"(H)×1.1"(D)]
<b>Mass (weight)</b>	Approx. 152 g/0.33 lb (with card and battery) Approx. 135 g/0.30 lb (excluding card and battery)
<b>Operating temperature</b>	0 °C to 40 °C (32 °F to 104 °F)
<b>Operating humidity</b>	10%RH to 80%RH

## Battery Charger:

Information for your safety

<b>Input:</b>	AC~110 V to 240 V, 50/60 Hz, 0.2 A
<b>Output:</b>	DC=4.2 V, 0.43 A

## Battery Pack (lithium-ion):

Information for your safety

<b>Voltage/capacity:</b>	3.6 V/660 mAh
--------------------------	---------------

## NOTE:(Only for "EB/EF/EG/EP" models)

- Data from the PC can not be written to the camera using the USB connection cable.

## Motion pictures

### (Only "EB/EF/EG/EP" models:)

- Motion pictures can be recorded continuously for up to 15 minutes.

### (Except "EB/EF/EG/EP" models:)

- Motion picture recorded continuously in [MOTION JPEG] or [HIGH SPEED MOVIE] in Scene Mode is up to 2 GB. Only the maximum recordable time for 2 GB is displayed on the screen.

## 5 Location of Controls and Components

- 1 Flash
- 2 Lens
- 3 Self-timer indicator  
AF Assist Lamp

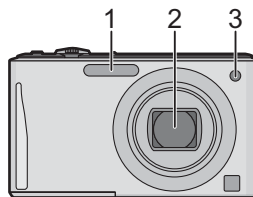

- 4 LCD monitor
- 5 [MENU/SET] button
- 6 [DISP.] button
- 7 [Q.MENU]/Delete/Cancel  
button
- 8 [MODE] button
- 9 [Rec]/[Playback] selector switch

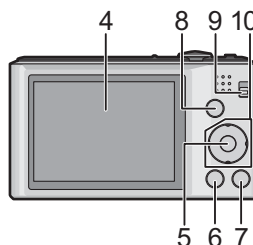

- 10 Cursor buttons
  - (A): ▲/Exposure compensation
  - (B): ▼/Macro Mode  
AF Tracking
  - (C): ◀/Self-timer
  - (D): ▶/Flash setting

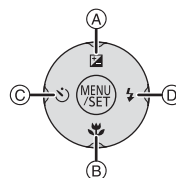

- 11 Strap eyelet
  - Be sure to attach the strap when using the camera to ensure that you will not drop it.
- 12 Lens barrel
- 13 [AV OUT/DIGITAL] socket

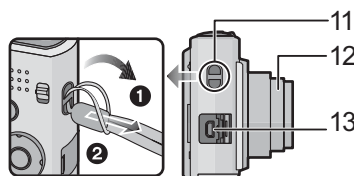

- 14 Camera ON/OFF switch
- 15 Zoom lever
- 16 Speaker
  - Do not cover the speaker with your fingers.
- 17 Microphone
- 18 Shutter button
- 19 [E.ZOOM] button
- 20 Tripod receptacle
- 21 Card/Battery door
- 22 DC coupler cover
  - When using an AC adaptor, ensure that the Panasonic DC coupler (optional) and AC adaptor (optional) are used.

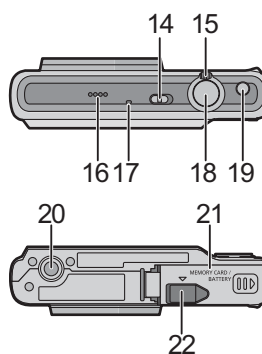

## Selecting the [Rec] Mode

**1** Slide the [Rec]/[Playback] selector switch to [📷].

**2** Press [MODE].

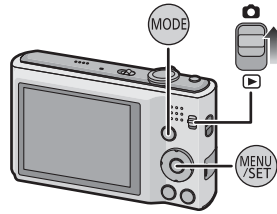

**3** Press ▲/▼/◀/▶ to select the mode.



**4** Press [MENU/SET].

### ■ List of [Rec] Modes

<b>iA</b>	<b>Intelligent Auto Mode</b>
The subjects are recorded using settings automatically selected by the camera.	
<b>📷</b>	<b>Normal Picture Mode</b>
The subjects are recorded using your own settings.	
<b>MS</b>	<b>My Scene Mode</b>
Pictures are taken using previously registered recording scenes.	
<b>SCN</b>	<b>Scene Mode</b>
This allows you to take pictures that match the scene being recorded.	
<b>📹</b>	<b>Motion Picture Mode</b>
This mode allows you to record motion pictures with audio.	

# 6 Service Mode

## 6.1. Error Code Memory Function

### 1. General description

This unit is equipped with history of error code memory function, and can be memorized 16 error codes in sequence from the latest. When the error is occurred more than 16, the oldest error is overwritten in sequence.

The error code is not memorized when the power supply is shut down forcibly (i.e., when the unit is powered on by the battery, the battery is pulled out) The error code is memorized to FLASH-ROM when the unit has just before powered off.

### 2. How to display

The error code can be displayed by ordering the following procedure:

#### • Preparation:

1. Attach the Battery or AC Adaptor with a DC coupler to the unit.

#### NOTE:

\*Since this unit has built-in memory, it can be performed without inserting SD memory card.

#### • Step 1. The temporary cancellation of "INITIAL SETTINGS":

Set the [ REC ]/[ PLAYBACK ] selector switch to "[ REC ] (Camera mark)".

While pressing "[ UP ] of Cursor button" and [ E.ZOOM ] button simultaneously, turn the Power on.

#### • Step 2. Execute the error code display mode:

Press the "[ LEFT ] of Cursor button", "[ MENU/SET ]" button and [ E.ZOOM ] button simultaneously.

The display is changed as shown below when the above buttons are pressed simultaneously.

Normal display → Error code display → Operation history display → Normal display → .....

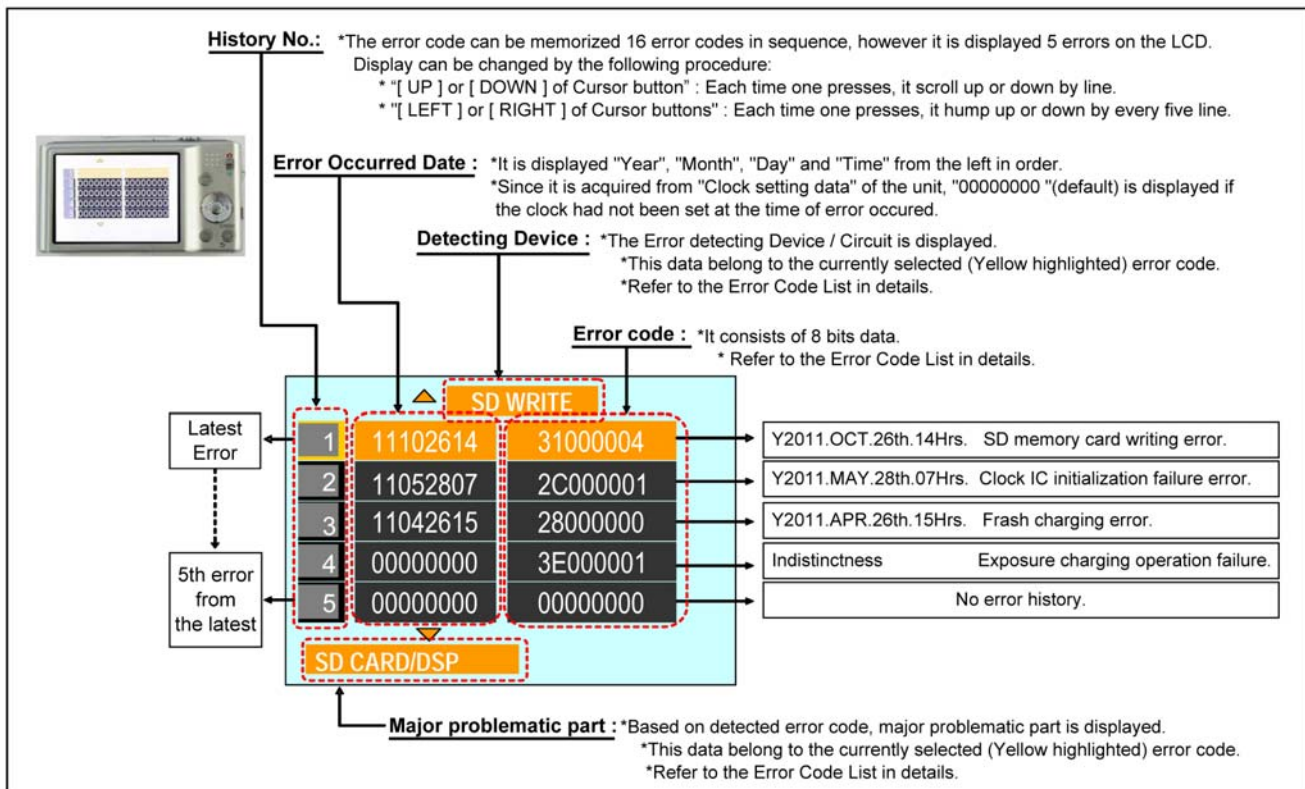

Example of Error Code Display



• 3. Error Code List

The error code consists of 8 bits data and it shows the following information.

Attribute	Main item	Sub item	Error code		Contents (Upper line)		Error Indication						
			High 4 bits	Low 4 bits	Problematic Part & Check point (Lower line)		Detecting device	Problematic Part/Circuit					
LENS	Lens drive	OIS	18*0	1000	PSD (X) error. Hall element (X axis) position detect error in OIS unit.	OIS Unit	OIS X	LENSu NG					
				2000	PSD (Y) error. Hall element (Y axis) position detect error in OIS unit.	OIS Unit	OIS Y						
				3000	GYRO (X) error. Gyro (IC7101: X axis) detect error on Sub P.C.B.	IC7101 (Gyro element) or IC6001 (VENUS 6)	GYRO X	GYRO NG					
			4000	GYRO (Y) error. Gyro (IC7101: Y axis) detect error on Sub P.C.B.	IC7101 (Gyro element) or IC6001 (VENUS 6)	GYRO Y							
			5000	MREF error (Reference voltage error).	IC9101 (SYSTEM) or IC6001 (VENUS 6)	OIS REF	LENSSd/DSP NG						
			6000	Drive voltage (X) error.	LENS Unit, LENS flex breaks, IC6001 (VENUS 6) AD value error, etc.	OISX REF	LENSu/LENS FPC						
			7000	Drive voltage (Y) error.	LENS Unit, LENS flex breaks, IC6001 (VENUS 6) AD value error, etc.	OISY REF							
			Zoom	0710	Collapsible barrel Low detect error (Collapsible barrel encoder always detects Low.)	Mechanical lock, FP9002-(2) signal line or IC6001 (VENUS 6)	ZOOM L	ZOOMm/LENSu					
					0720	Collapsible barrel High detect error (Collapsible barrel encoder always detects High.)	Mechanical lock, FP9002-(2) signal line or IC6001 (VENUS 6)		ZOOM H				
		0730			Zoom motor sensor error.	Mechanical lock, FP9002-(32), (35) signal line or IC6001 (VENUS 6)	ZOOM ENC						
		0740		Zoom motor sensor error. (During monitor mode.)	Mechanical lock, FP9002-(32), (35) signal line or IC6001 (VENUS 6)								
		0750		Zoom motor sensor error. (During monitor mode with slow speed.)	Mechanical lock, FP9002-(32), (35) signal line or IC6001 (VENUS 6)								
		Focus		0701	HP Low detect error (Focus encoder always detects High, and not becomes Low)	Mechanical lock, FP9002-(2) signal line or IC6001 (VENUS 6)	FOCUS L		LENS FPC/DSP				
			0702	HP High detect error (Focus encoder always detects Low, and not becomes High)	Mechanical lock, FP9002-(2) signal line or IC6001 (VENUS 6)	FOCUS H							
		Lens	18*1	0000	Power ON time out error.	LENS drive system	LENS DRV	LENSu					
				0000	Power OFF time out error.	LENS drive system							
		Adj. History	OIS	19*0	2000	OIS adj. Yaw direction amplitude error (small)	OIS ADJ	OIS ADJ					
					3000	OIS adj. Pitch direction amplitude error (small)							
	4000				OIS adj. Yaw direction amplitude error (large)								
	5000				OIS adj. Pitch direction amplitude error (large)								
	6000				OIS adj. MREF error								
	7000				OIS adj. time out error								
	8000				OIS adj. Yaw direction off set error								
	9000				OIS adj. Pitch direction off set error								
A000	OIS adj. Yaw direction gain error												
B000	OIS adj. Pitch direction gain error												
C000	OIS adj. Yaw direction position sensor error												
D000	OIS adj. Pitch direction position sensor error												
E000	OIS adj. other error												
HARD	VENUS A/D				Flash	28*0			0000	Flash charging error.	IC6001-(AC16) signal line or Flash charging circuit	STRB CHG	STRB PCB/FPC
	FLASH ROM (EEPROM Area)				FLASH ROM (EEPROM Area)	2B*0			0001	EEPROM read error	IC6002 (FLASH ROM)	FROM RE	FROM
		0002	EEPROM write error	IC6002 (FLASH ROM)			FROM WR	FROM					
		0005	Firmware version up error	Replace the firmware file in the SD memory card.			(No indication)	(No indication)					
		0008	SDRAM error	SDRAM Mounting defective									
	SYSTEM	RTC	2C*0	0001	SYSTEM IC initialize failure error	Communication between IC6001 (VENUS 6) and IC9101 (SYSTEM)	SYS INIT	MAIN PCB					
	SOFT	CPU	Reset	30*0	0001	NMI reset	Non Mask-able Interrupt (30000001-30000007 are caused by factors)	NMI RST	MAIN PCB				
Card		Card	31*0	0001	Card logic error	SD memory card data line or IC6001 (VENUS 6)	SD CARD	SD CARD/DSP					
				0002	Card physical error	SD memory card data line or IC6001 (VENUS 6)							
				0004	Write error	SD memory card data line or IC6001 (VENUS 6)	SD WRITE						
				0005	Format error		INMEMORY		FROM				
CPU, ASIC hard		Stop	38*0	0001	Camera task finish process time out.	Communication between Lens system and IC6001 (VENUS 6)	LENS COM	LENSu/DSP					
					0002	Camera task invalid code error.	IC6001 (VENUS 6)	DSP	DSP				
					0100	File time out error in recording motion image	IC6001 (VENUS 6)						
				0200	File data cue send error in recording motion image	IC6001 (VENUS 6)							
				0300	Single or burst recording brake time out.		(No indication)	(No indication)					
Memory area		3A*0	0008	USB work area partitioning failure	USB dynamic memory securing failure when connecting	(No indication)	(No indication)						
Operation		Power on	3B*0	0000	FLASH ROM processing early period of camera during movement.		INIT	(No indication)					
Zoom	Zoom	3C*0	0000	Inperfect zoom lens processing	Zoom lens	ZOOM	ZOOMm/LENSu						
			35*0	0000	Software error (0-7bit : command, 8-15bit : status)		DSP	DSP					
			35*1	0000	Though record preprocessing is necessary, it is not called.		(No indication)	(No indication)					
			35*2	0000	Though record preprocessing is necessary, it is not completed.		(No indication)	(No indication)					

## Important notice about "Error Code List"

### 1) About "\*" indication:

The third digit from the left is different as follows.

- In case of 0 (example: 18001000)

When the third digit from the left shows "0", this error occurred under the condition of INITIAL SETTINGS has been completed.

It means that this error is occurred basically at user side.

- In case of 8 (example: 18801000)

When the third digit from the left shows "8", this error occurred under the condition of INITIAL SETTINGS has been released.

(Example; Factory assembling-line before unit shipment, Service mode etc.)

It means that this error is occurred at service side.

### 2) About "?" indication: ("18\*0 0?01" to "18\*0 0?50"):

The third digit from the right shows one of the hexadecimal ("0" to "F") character.

## • 4. How to exit from Error Code display mode:

Simply, turn the power off. (Since Error code display mode is executed under the condition of temporary cancellation of "INITIAL SETTINGS", it wake up with normal condition when turn off the power.)

### NOTE:

The error code can not be initialized.

## 6.2. ICS (Indication of additional Camera Settings when picture was taken) function

### 1. General description

This unit is equipped with ICS (ICS: Indication of additional Camera Settings when picture was taken) function by playing back the concerned picture on the LCD display.

(This function is achieved by utilizing "maker note" data stored in Exif data area of recorded picture file.)

To proceed failure diagnosis, use this ICS function together with "displaying the recorded picture with picture information" function.

### NOTE:

- The ICS function operates with a picture which is only taken with the same model. (It may not be displayed when the picture was taken with other model.)
- Since Exif data is not available after the picture is edited by PC, the ICS function may not be activated.

### 2. How to display

The ICS data is displayed by ordering the following procedure:

#### • Preparation:

1. Attach the Battery or AC Adaptor with a DC coupler to the unit.

### NOTE:

Since this unit has built-in memory, it can be performed without inserting SD memory card.

#### • Step 1. The temporary cancellation of "INITIAL SETTINGS":

Set the [ REC ]/[ PLAYBACK ] selector switch to "[ REC ] (Camera mark)".

While pressing "[ UP ] of Cursor button" and [ E.ZOOM ] button simultaneously, turn the Power on.

#### • Step 2. Execute the ICS display mode:

Set the [ REC ]/[ PLAYBACK ] selector switch to "[ PLAYBACK ]".

Select the concerned picture by pressing the "[ LEFT ] and [ RIGHT ] of Cursor button".

Press the "[ LEFT ] of Cursor button", [ MENU/SET ] button and [ E.ZOOM ] button simultaneously.

Press the [ DISP. ] button, 3 times.

The display condition is changed as shown below when the [ DISP. ] button is pressed.

Code display → Code + Picture display (1) → Code + Picture display (2) → ICS display → Code display .....

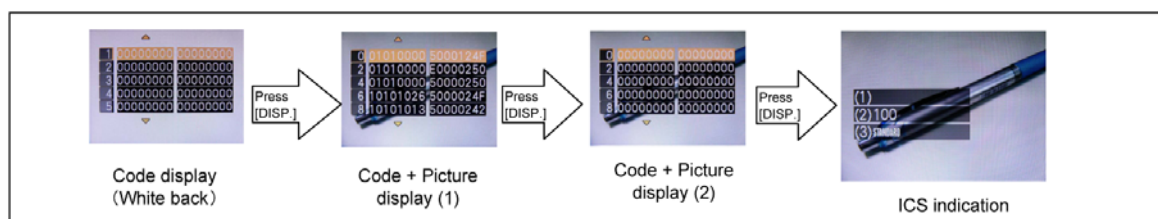

### 3. How to read

**(1). Jitter alert was displayed or not:**  
 This part shows that the "Jitter alert" mark was displayed or not when the picture has just before been taken.  
 +.With "Jitter alert" mark : The "Jitter alert" mark was displayed.  
 +.Without "Jitter alert" mark: The "Jitter alert" mark was not displayed.  
 [About "Jitter alert" mark]  
 Due to lacking the enough light amount etc, shooting condition prone to make a "hand jitter", the "Jitter alert" mark is displayed.  
 [Reference Guide]  
 (Applicable settings : Normal picture mode, ISO100, WIDE edge, Flash OFF)  
 +.The "Jitter alert" mark is displayed when the shutter speed is 1/15th and below.

**(2). ISO Sensitivity Setting condition:**  
 This part shows that the "ISO Sensitivity" setting condition when the picture had been taken.  
 (Note: The [i ISO] is displayed when the "Intelligent ISO" was selected.)  
 For instance, when the recorded picture information shows [ISO100], it can be confirmed the ISO setting condition ; [AUTO], [INTELLIGENT ISO] or [ISO 100](Fixed: set by user).  
 [Point for Confirmation]  
 \*The symptom is "Picture with "hand jitter". Subject is not clearly stopped." in darker scene, does the picture was taken with lower ISO setting mode?  
 \*The symptom is "Noisy picture. Rough picture image" in brighter scene, does the picture was taken with higher ISO setting mode?

**(3). Color mode Setting condition:**  
 This part shows that the "Color mode" setting condition when the picture had been taken.  
 [Point for Confirmation]  
 \*The symptom is "Color is strange. The picture is bluish (Yellowish) ", does the picture was taken with [SEPIA] / [COOL] / [WARM] settings?  
 NOTE: As for the symptom related with the color, confirm the picture information which is displayed in normal playback screen as well.  
 (In normal playback screen, the setting condition of "White balance" and "WB Adjustment "can be confirmed.)

Normal playback screen  
(Recorded picture with information)



\*In playback mode, the picture information is displayed when pressing the [DISP.] button. (It can be confirmed at user as well.)  
 \*Use this indication together with ICS function

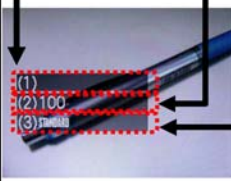

[ICS display (Sample)]

(1). Jitter alert mark : [Indicated]  
 (2). ISO sens. setting : ISO100  
 (3). Color mode setting: Standard

[Reference Guide : Settings "When taking picture"]

**<ISO SENSITIVITY>**  
 \*This allows the sensitivity to light (ISO sensitivity) to be set. Setting to a higher figure enables pictures to be taken even in dark places without the resulting pictures coming out dark.  
 \*In this unit, it can be set one of the [AUTO], [100], [200], [400], [800] and [1600] in "Normal shooting" mode.  
 \*In Intelligent Auto Mode, shutter speed changes depending on the identified scene.

	[100] ←	→ [1600]
Recording location (recommended)	When it is light (outdoors)	When it is dark
Shutter speed	Slow	Fast
Noise	Less	Increased
Jitter of the subject	Increased	Less

**<COLOR MODE>**  
 \*Using these modes, the pictures can be made sharper or softer, the colors of the pictures can be turned into sepia colors or other color effects can be achieved.  
 \*In this unit, it can be set one of the following effects in "Normal shooting" mode.

[STANDARD] : This is the standard setting.	[B/W] : The picture becomes black and white
[Happy]*1 : Image with enhanced brightness and vividness.	[SEPIA] : The picture becomes sepia.
[NATURAL]*2 : The picture becomes softer.	[COOL]*2 : The picture becomes bluish.
[VIVID]*2 : The picture becomes sharper.	[WARM]*2 : The picture becomes reddish.

\*When you take pictures in dark places, noise may become visible. To avoid noise, we recommend setting to [NATURAL].



### 4. How to exit:

Simply, turn the power off. (Since ICS function is executed under the condition of temporary cancellation of "INITIAL SETTINGS", it wake up with normal condition when turn off the power.)

# 7 Service Fixture & Tools

## 7.1. Service Fixture and Tools

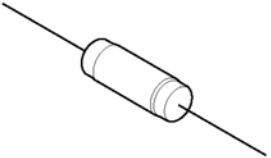
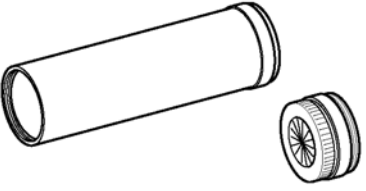
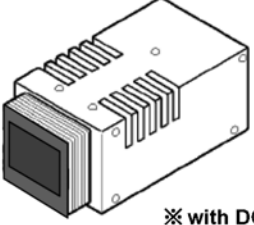
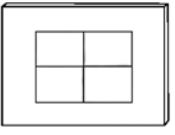
The following Service Fixture and tools are used for checking and servicing this unit.

<b>Resistor for Discharging</b> <b>ERG5SJ102</b>	<b>Infinity Lens (with Focus Chart)</b> <b>VFK1164TCM02</b>	<b>LIGHT BOX</b> <b>RFKZ0523</b>
 <b>An equivalent type of Resistor may be used.</b>	 <b>* VFK1164TCM03 can be used.</b> <b>* RFKZ0422 can be used.</b>	 <b>※ with DC Cable</b> <b>* VFK1164TDVLB can be used.</b>
<b>TR Chart</b> <b>RFKZ0443</b>	<b>Lens Cleaning Kit (BK)</b> <b>VFK1900BK</b>	<b>Grease (for lens)</b> <b>RFKZ0472</b>
	 <b>* Only supplied as 10 set/box.</b>	

## 7.2. When Replacing the Main P.C.B.

After replacing the MAIN P.C.B., be sure to achieve adjustment.

The adjustment instruction is available at "software download" on the "Support Information from NDBG/VDBG-AVC" web-site in "TSN system", together with Maintenance software.

## 7.3. Service Position

This Service Position is used for checking and replacing parts. Use the following Extension cables for servicing.

Table S1 Extension Cable List

No.	Parts No.	Connection	Form
1	RFKZ0581	FP9001 (MAIN) - CCD UNIT	47PIN 0.3FFC
2	RFKZ0416	FP9002 (MAIN) - LENS UNIT	41PIN 0.3FFC
3	RFKZ0416	FP9003 (MAIN) - LCD UNIT	41PIN 0.3FFC
4	RFKZ0418	PP9001 (MAIN) - PS8001 (FLASH TOP)	30PIN B to B
5	RFKZ0553	PS9001 (MAIN) - PP9501 (SUB)	16PIN B to B

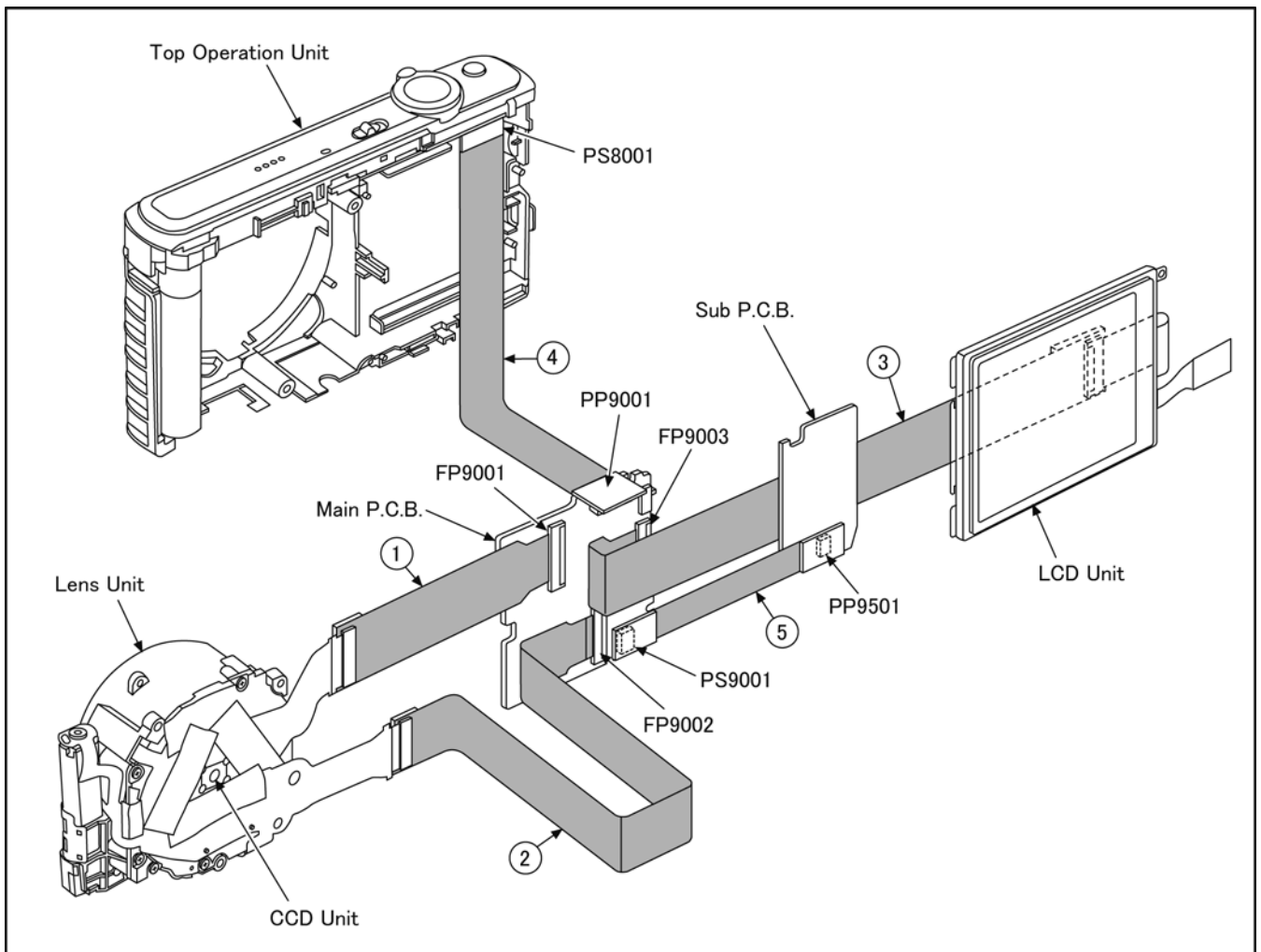

### CAUTION-1. (When servicing FLASH TOP P.C.B.)

1. Be sure to discharge the E.capacitor on FLASH TOP P.C.B..  
Refer to "HOW TO DISCHARGE THE E.CAPACITOR ON FLASH TOP P.C.B.". The E.capacitor voltage is not lowered soon even if the AC Cord is unplugged or the battery is removed.
2. Be careful of the high voltage circuit on FLASH TOP P.C.B..
3. DO NOT allow other parts to touch the high voltage circuit on FLASH TOP P.C.B..

# 8 Disassembly and Assembly Instructions

## 8.1. Disassembly Flow Chart

This is a disassembling chart.

When assembling, perform this chart conversely.

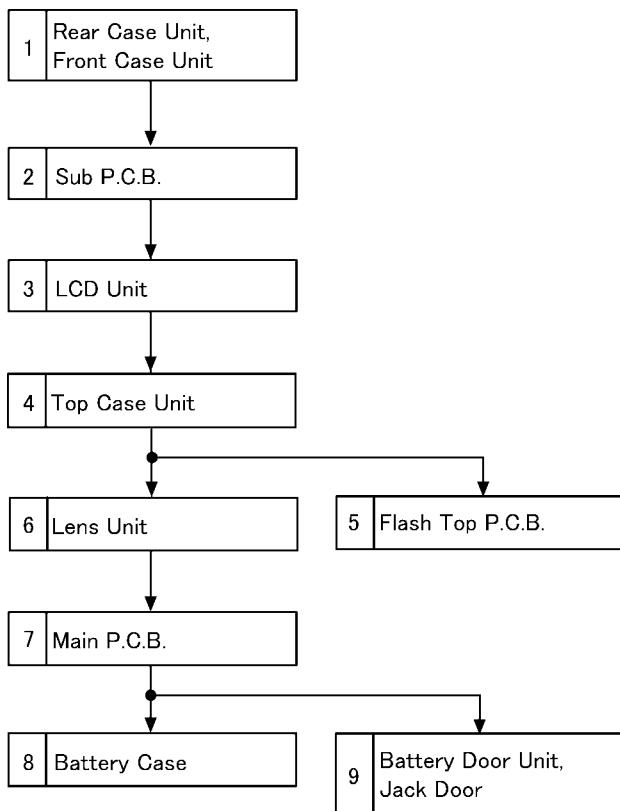

## 8.2. PCB Location

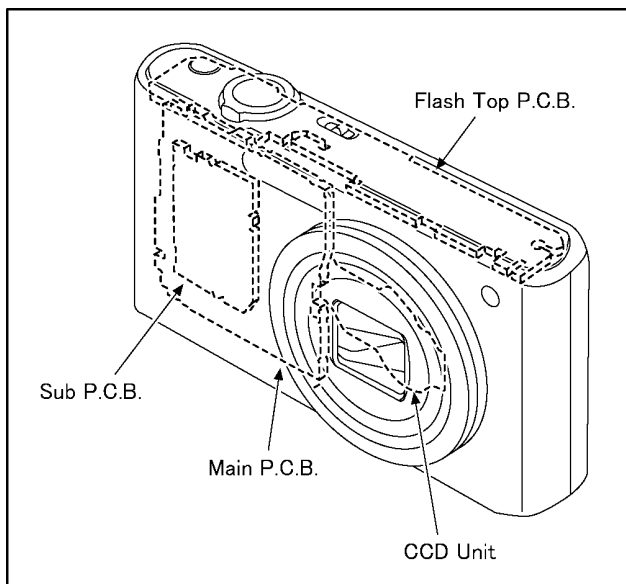

### 8.3. Disassembly Procedure

No.	Item	Fig	Removal
1	Rear Case Unit Front Case Unit	(Fig. D1)	Card
			Battery
			6 Screws (A)
		(Fig. D2)	3 Screws (B)
			2 Locking tabs
2	Sub P.C.B.	(Fig. D3)	PP9501(Connector)
			Sub P.C.B.
3	LCD Unit	(Fig. D4)	2 Locking tabs
			PCB Spacer
			MODE Knob
			1 Screw (C)
		(Fig. D5)	FP9003(Flex)
4	Top Case Unit	(Fig. D6)	LCD Unit
			3 Screws (D)
			Frame Plate
			Tripod Fixing Plate
			PS8001(Connector)
5	Flash Top P.C.B.	(Fig. D7)	Top Case Unit
			2 Locking tabs
			AF Panel Light
			2 Screws (E)
			3 Locking tabs
			Flash Top P.C.B.
			2 Locking tabs
			Speaker
			Mic Damper
			Power Knob Base
			Power Knob
			EZ Button
			Top Ornament Unit
			(Fig. D8)
6	Lens Unit	(Fig. D9)	DPR Sheet
			FP9001(Flex)
			FP9002(Flex)
			Lens Unit
7	Main P.C.B.	(Fig. D10)	1 Screw (F)
			1 Locking tab
			Main P.C.B.
8	Battery Case	(Fig. D11)	1 Locking tab
			Battery Out Spring
			Battery Case
9	Battery Door Unit Jack Door	(Fig. D12)	Battery Door Shaft
			Battery Door Unit
			Jack Door Shaft
			Jack Door

### 8.3.1. Removal of the Rear Case Unit and Front Case Unit

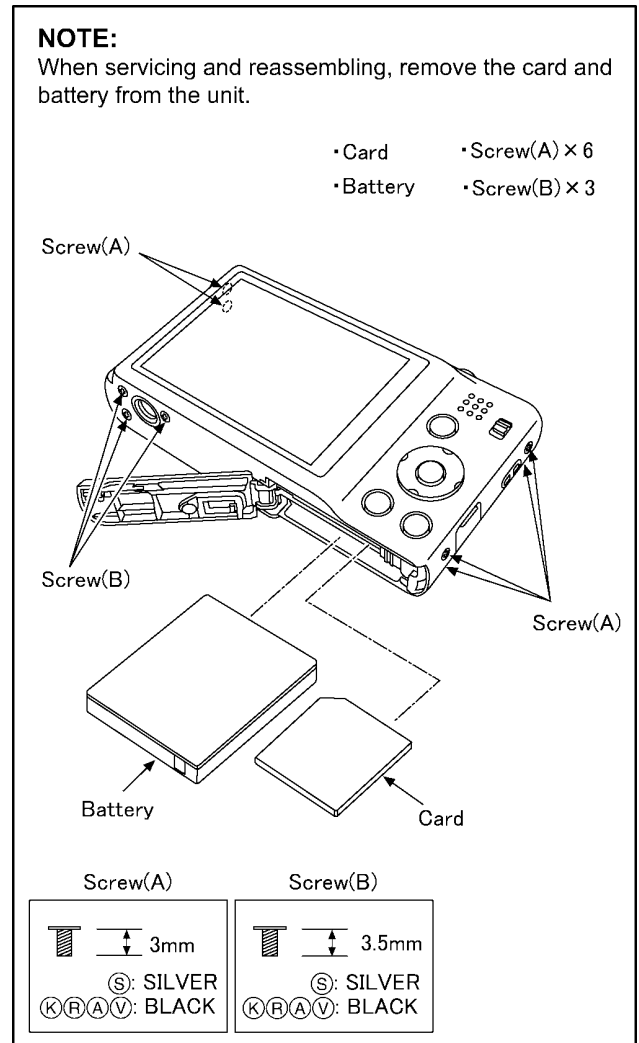

(Fig. D1)

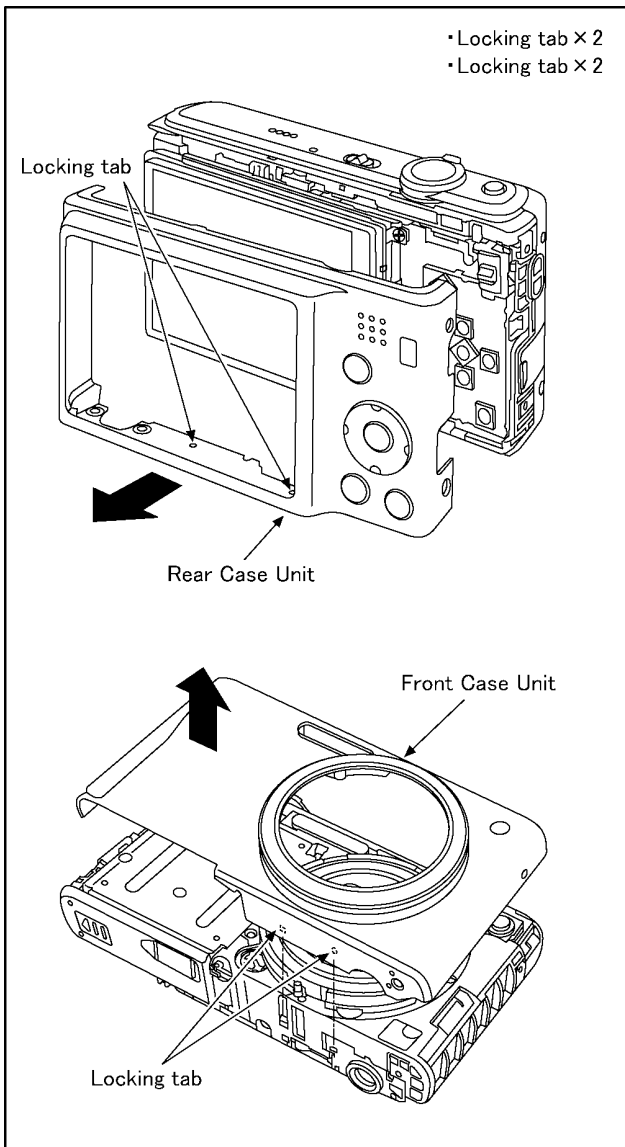

(Fig. D2)

### 8.3.2. Removal of the Sub P.C.B.

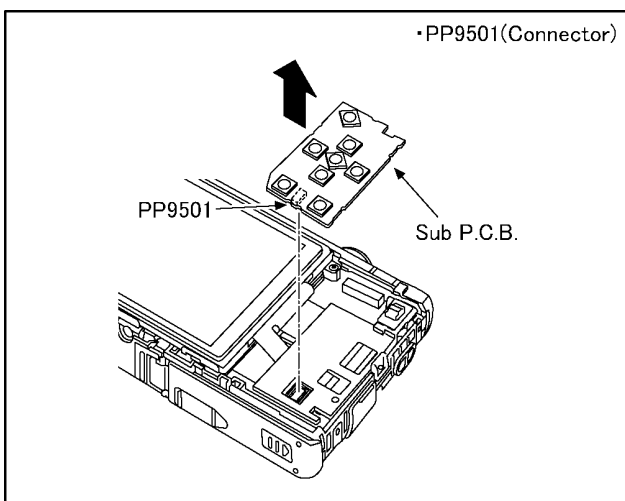

(Fig. D3)

### 8.3.3. Removal of the LCD Unit

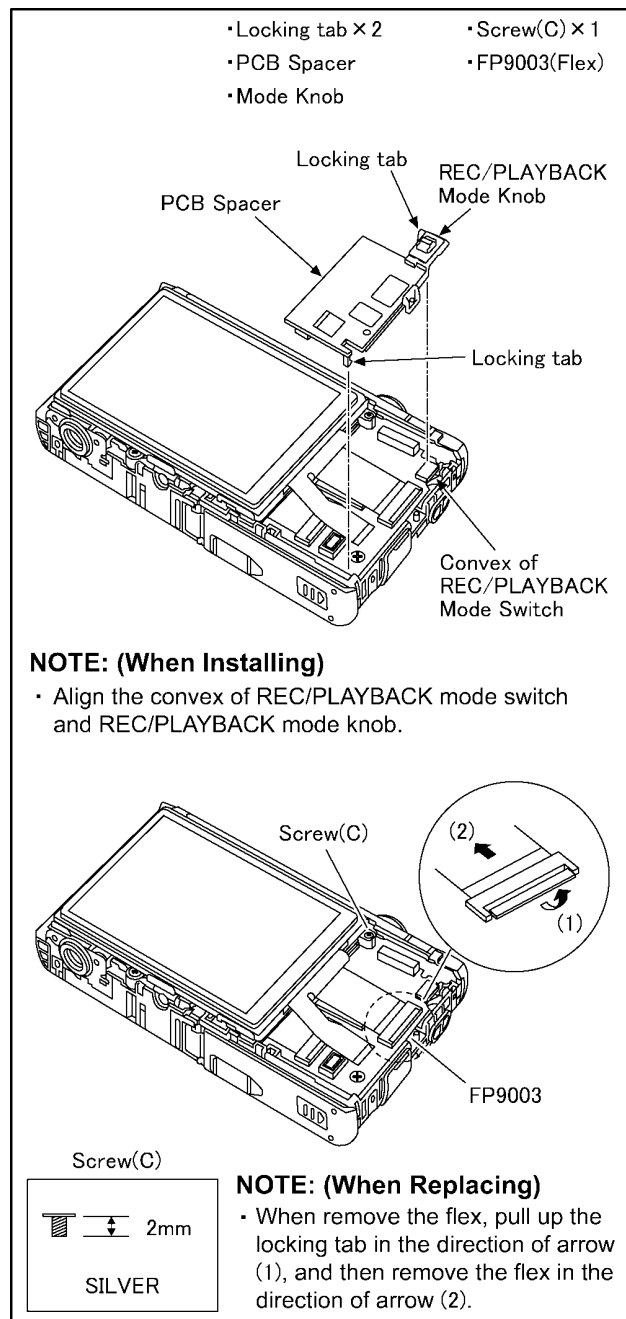

(Fig. D4)



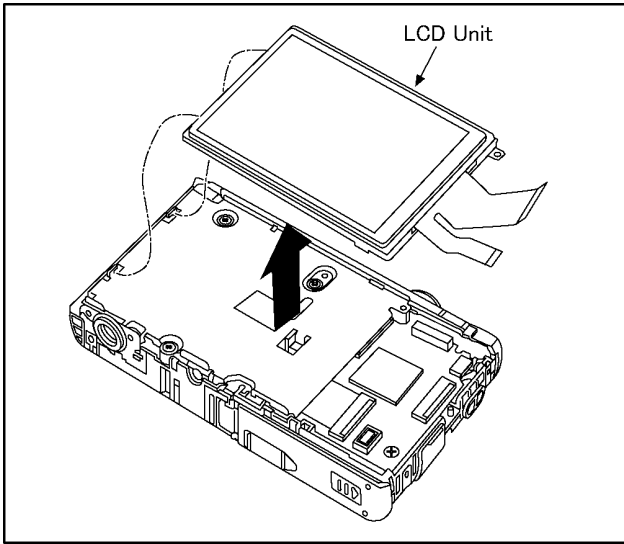

(Fig. D5)

### 8.3.4. Removal of the Top Case Unit

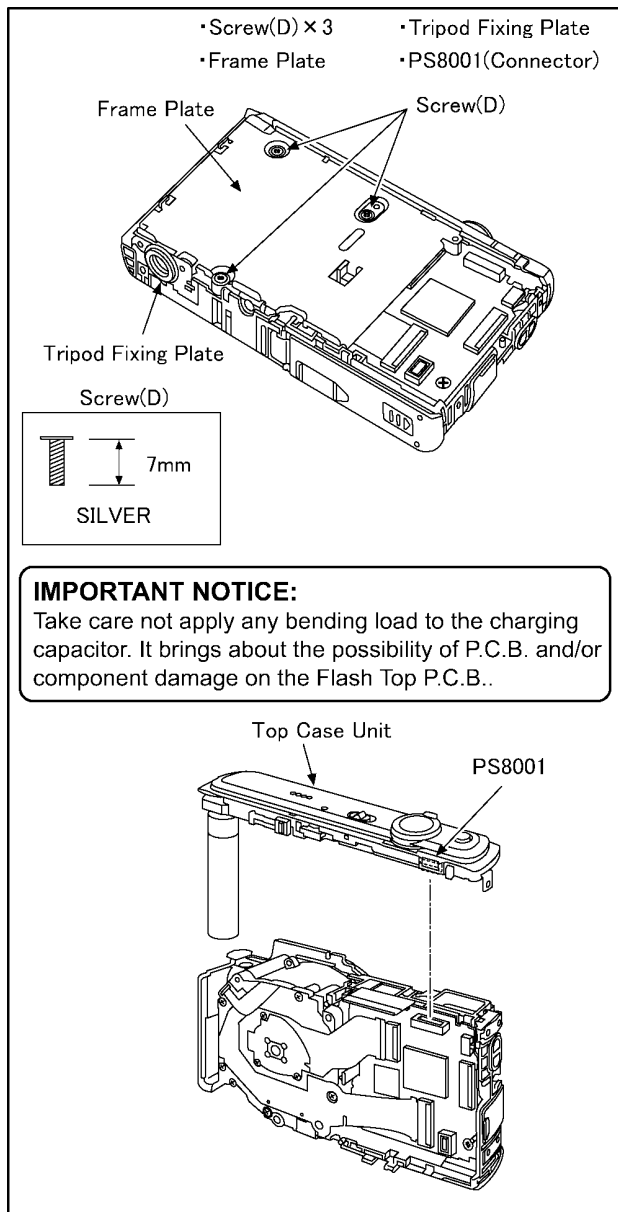

(Fig. D6)

### 8.3.5. Removal of the Flash Top P.C.B.

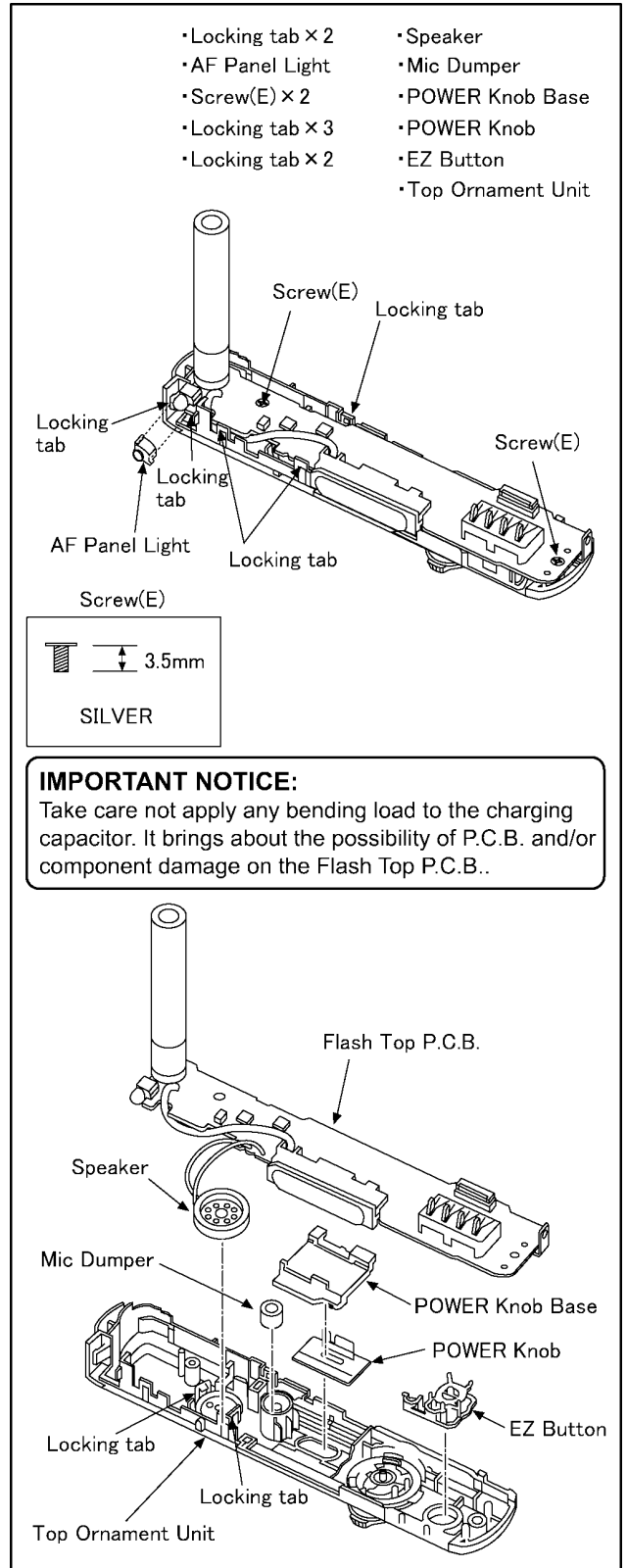

(Fig. D7)

**IMPORTANT NOTICE:**

Take care not apply any bending load to the charging capacitor. It brings about the possibility of P.C.B. and/or component damage on the Flash Top P.C.B..

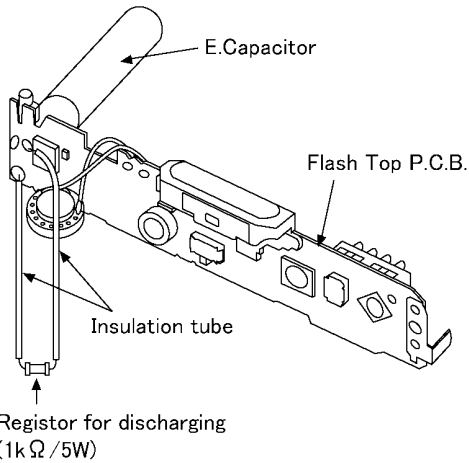

**CAUTION**

Be sure to discharge the E.Capacitor on Flash Top P.C.B. before disassembling.

1. Remove the Flash Top P.C.B..
2. Put the insulation tube on the lead part of resistor (ERG5SJ102: 1kΩ/5W).
3. Put the resistor between both terminals of E.Capacitor unit for approx. 5 seconds.

**NOTE:(When Installing)**

•Align the convex of power switch and power knob.

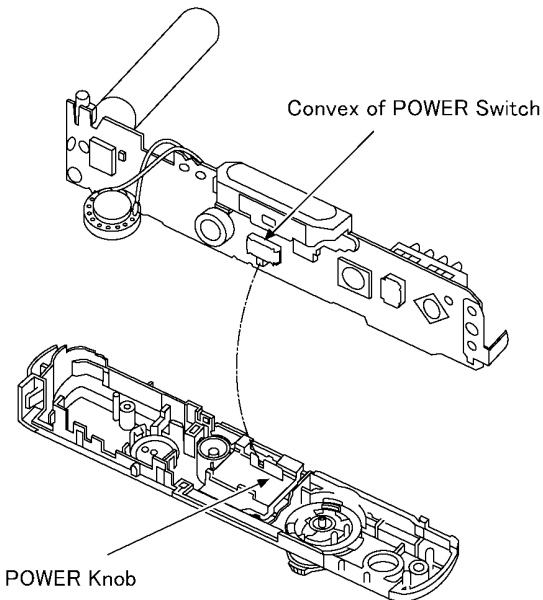

(Fig. D8)

**8.3.6. Removal of the Lens Unit**

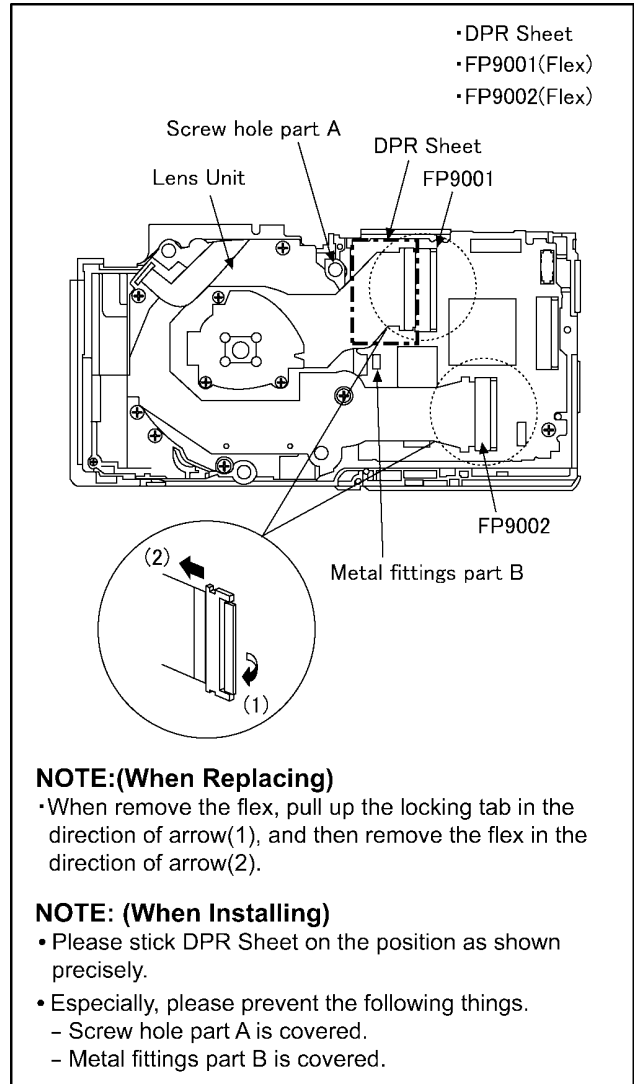

**NOTE:(When Replacing)**

•When remove the flex, pull up the locking tab in the direction of arrow(1), and then remove the flex in the direction of arrow(2).

**NOTE: (When Installing)**

- Please stick DPR Sheet on the position as shown precisely.
- Especially, please prevent the following things.
  - Screw hole part A is covered.
  - Metal fittings part B is covered.

(Fig. D9)

**8.3.7. Removal of the Main P.C.B.**

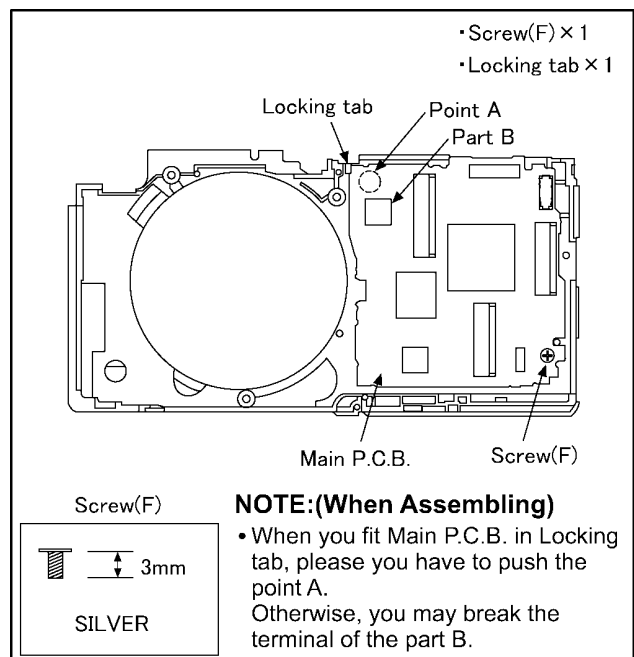

(Fig. D10)

### 8.3.8. Removal of the Battery Case

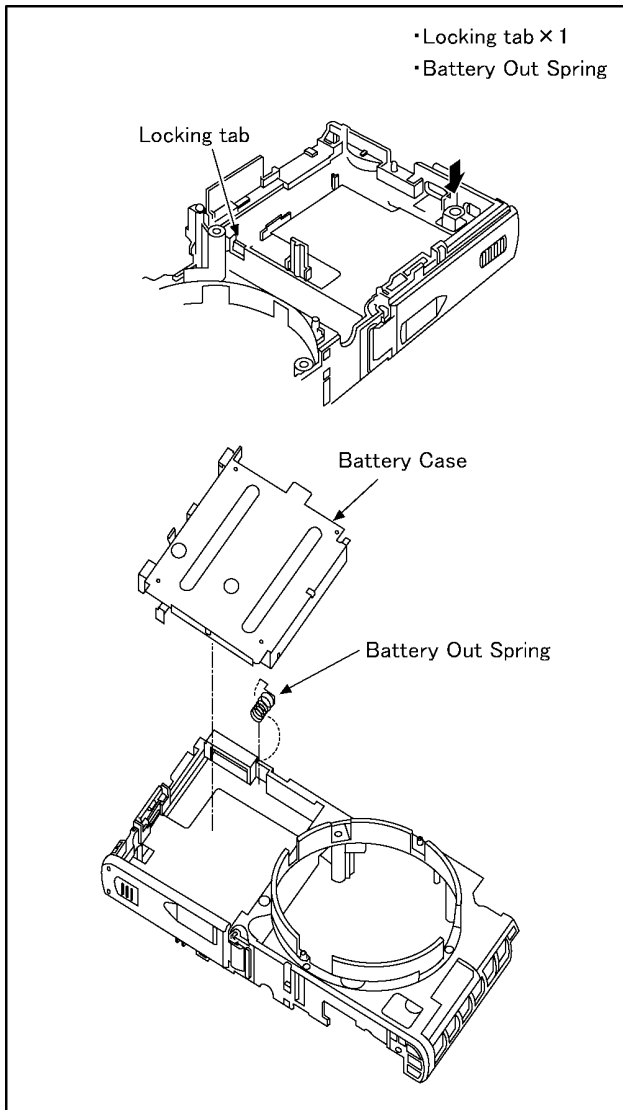

(Fig. D11)

### 8.3.9. Removal of the Battery Door Unit and Jack Door

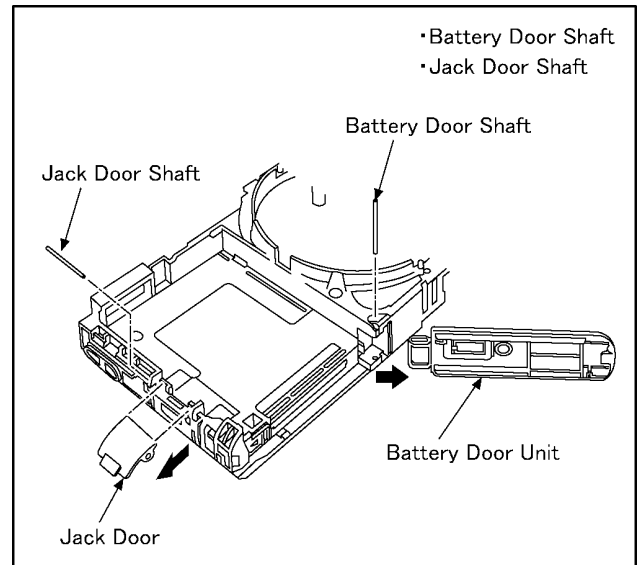

(Fig. D12)

#### NOTE: (When Installing)

- Make sure to confirm the following points when installing.
- The Screw is tightened enough.
  - Installing conditions are fine. (No distortion, no abnormal-space.)
  - No dust and/or dirt on Lens surfaces.
  - LCD image is fine. (No dust and dirt on it, and no gradient images.)

## 8.4. Lens Disassembly Procedure

### Precaution:

1. Do not remove the CCD when disassembling or re-assembling the lens in order to maintain it clean.  
When remove it, refer to item "8.6."
2. Keep dust or dirt away from the lens.
3. To remove dirt or dust from the lens, blow with dry air.
4. Do not touch the lens surface.
5. Apply grease (RFKZ0472) as shown on "THE APPLICATION OF GREASE METHOD" in the figure.
6. Apply a light coat of grease using an object similar to a toothpick.
7. The drive frame unit and penetration cam frame should be replaced as a unit.

### 8.4.1. Removal of the Zoom Motor and Lens FPC Unit

1. Remove the 3 tapes.
2. Unscrew the 2 screws (A).
3. Remove the zoom motor to the direction of arrow (1).
4. Unscrew the 1 screw (B).
5. Remove the photo sensor.
6. Remove the 13 solders (A).
7. Remove the 3 solders (B).
8. Remove the 5 locks.

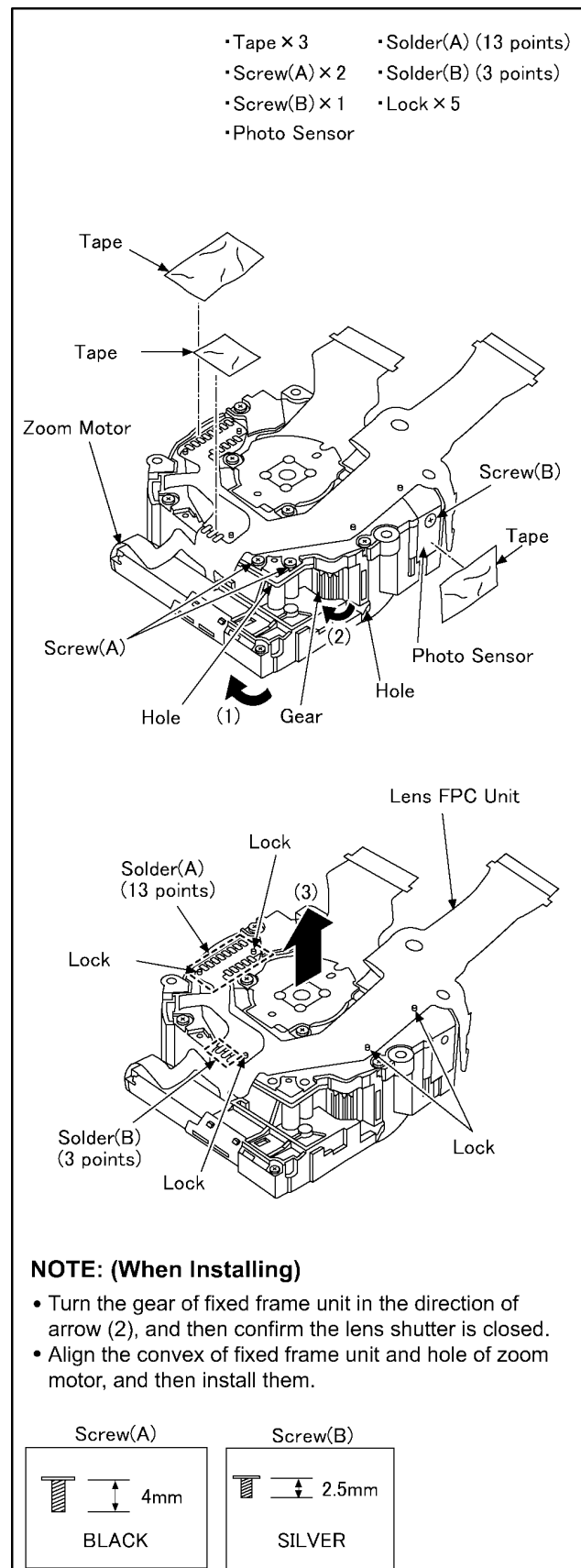

9. Remove the 4 solders (C).
10. Remove the lens FPC unit to the direction of arrow (3).

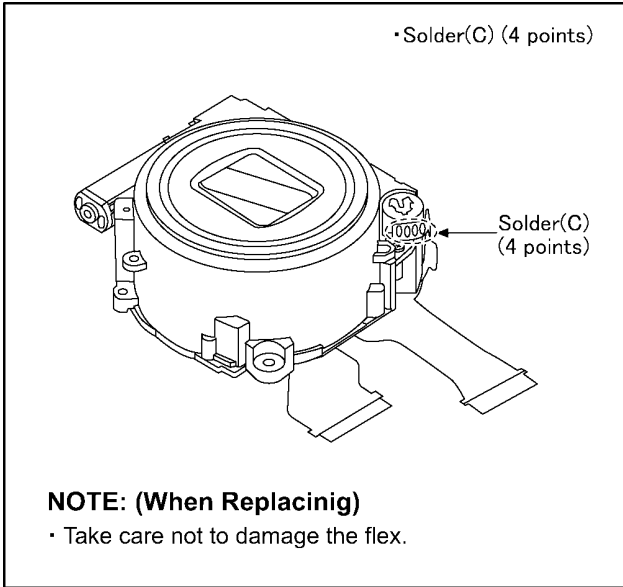

### 8.4.2. Removal of the Master Flange Unit

1. Unscrew the 4 screws (C).

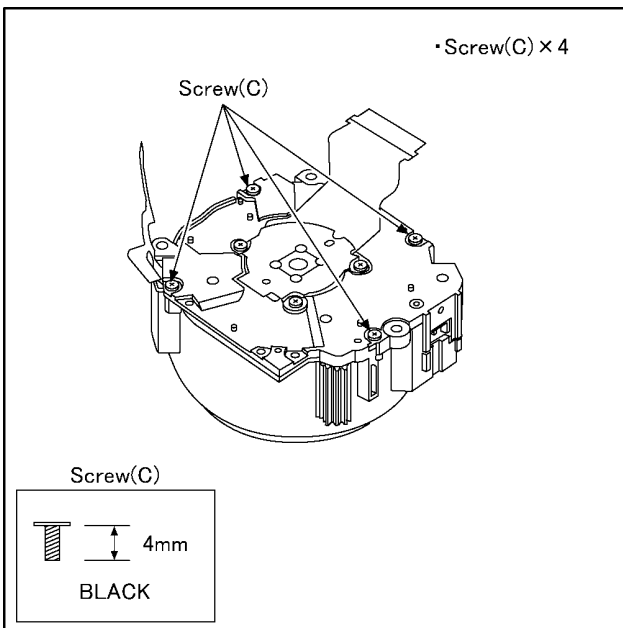

2. Remove the master flange unit.

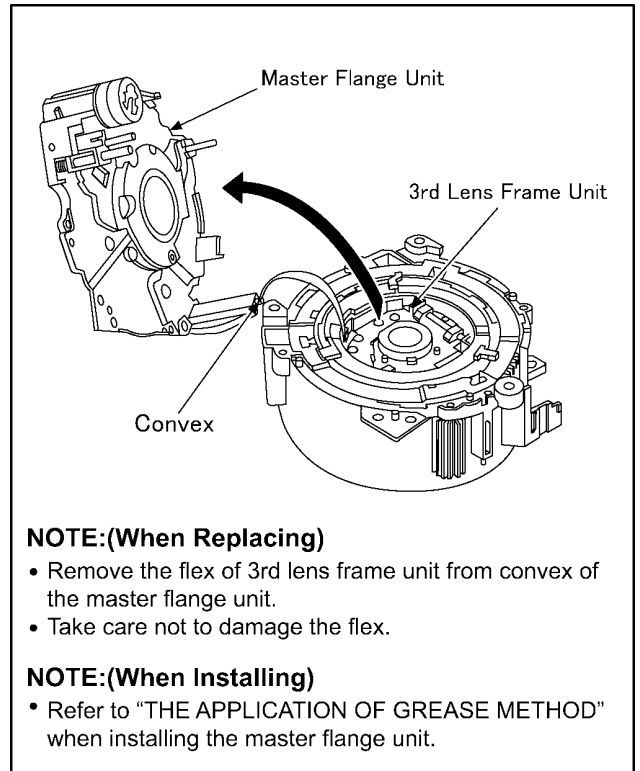

### 8.4.3. Removal of the 1st Lens Frame Unit/2nd Lens Frame Unit/Both Sides Cam Frame/2nd 3rd Direct Frame/3rd Lens Frame Unit

1. Push the both sides cam frame from the lens front side in the direction of arrow, and then remove the unit of 1st lens frame unit/2nd lens frame unit/both sides cam frame/2nd 3rd direct frame/3rd lens frame unit from the fixed frame unit/drive frame unit/penetration cam frame/1st direct frame unit.

#### ■ CAUTION

- The "Drive/Penetration Frame Unit" should be replaced as a unit. Do not replace/exchange only single part, individually.

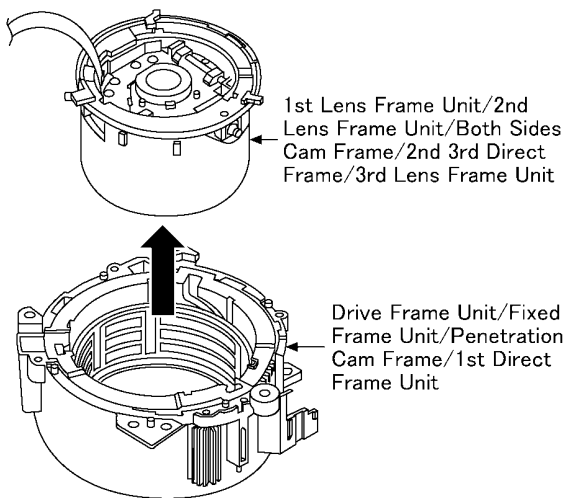

#### NOTE: (When Replacing)

- Take care not to damage the flex.
- When lift the 1st lens frame unit/2nd lens frame unit/both sides cam frame/2nd 3rd direct frame/3rd lens frame unit, take care not to put fingerprint of the lens.

### 8.4.4. Removal of the 2nd Lens Frame Unit/Both Sides Cam Frame/2nd 3rd Direct Frame/3rd Lens Frame Unit

1. Turn the 2nd lens frame unit/both sides cam frame/2nd 3rd direct frame/3rd lens frame unit in the direction of the arrow (1) fully, and then remove them in the direction of the arrow (2).

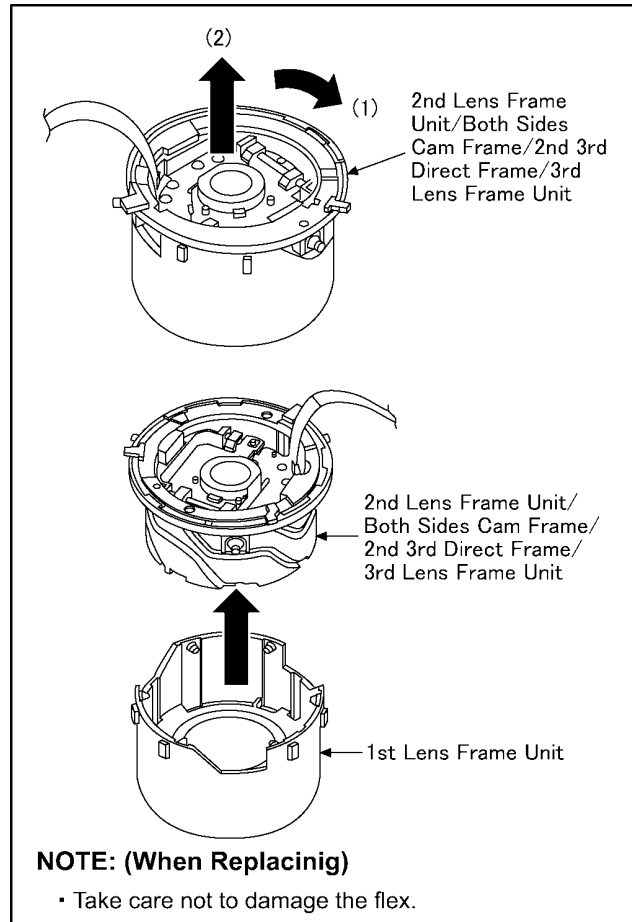

#### NOTE: (When Replacinig)

- Take care not to damage the flex.

### 8.4.5. Removal of the 2nd 3rd Direct Frame

1. Remove the 2nd 3rd direct frame in the direction of the arrow.

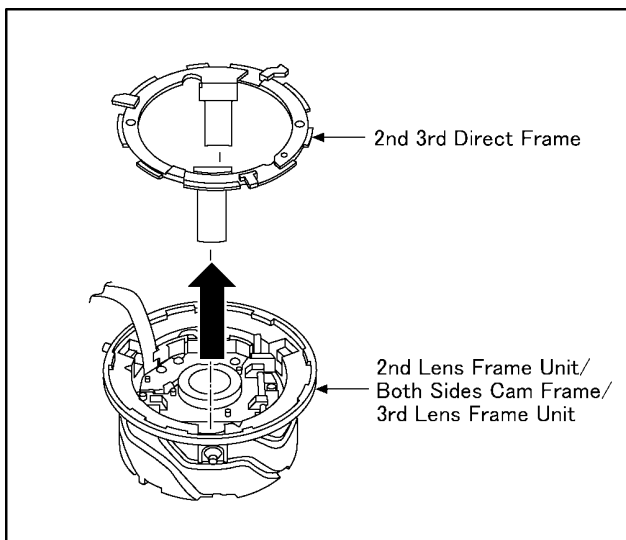

### 8.4.6. Removal of the 3rd Lens Frame Unit

1. Remove the 3rd lens frame unit in the direction of the arrow.

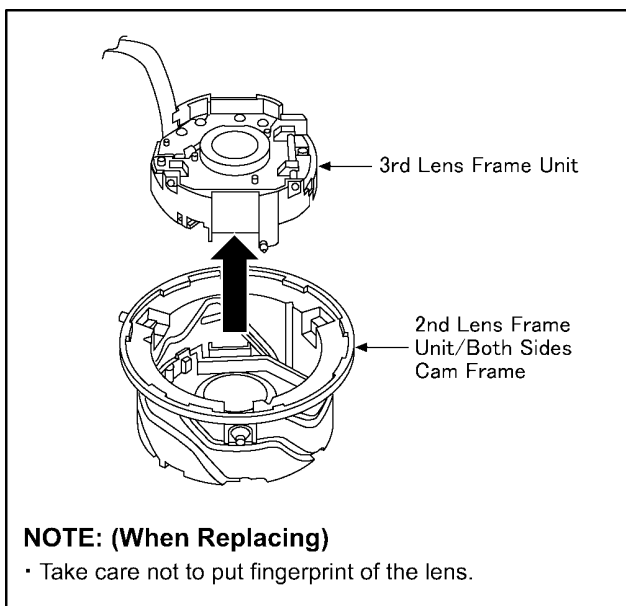

### 8.4.7. Removal of the 2nd Lens Frame Unit

1. Turn the 2nd lens frame unit in the direction of the arrow (1) fully, and then remove it in the direction of the arrow (2).

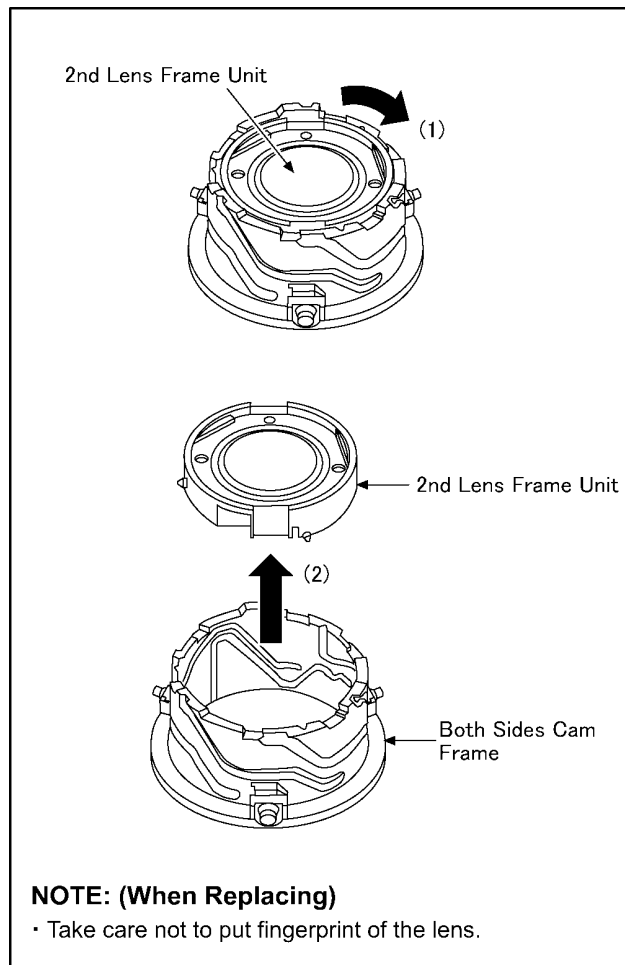

### 8.4.8. Removal of the 1st Direct Frame Unit

1. Remove the 1st direct frame unit in the direction of the arrow.

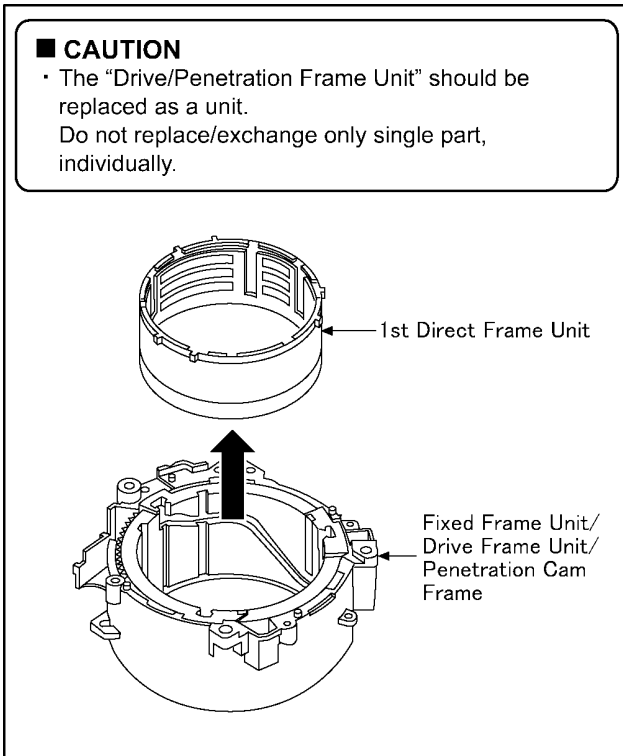

### 8.4.9. Removal of the Drive/Penetration Frame Unit

1. Remove the drive/penetration frame unit in the direction of the arrow.

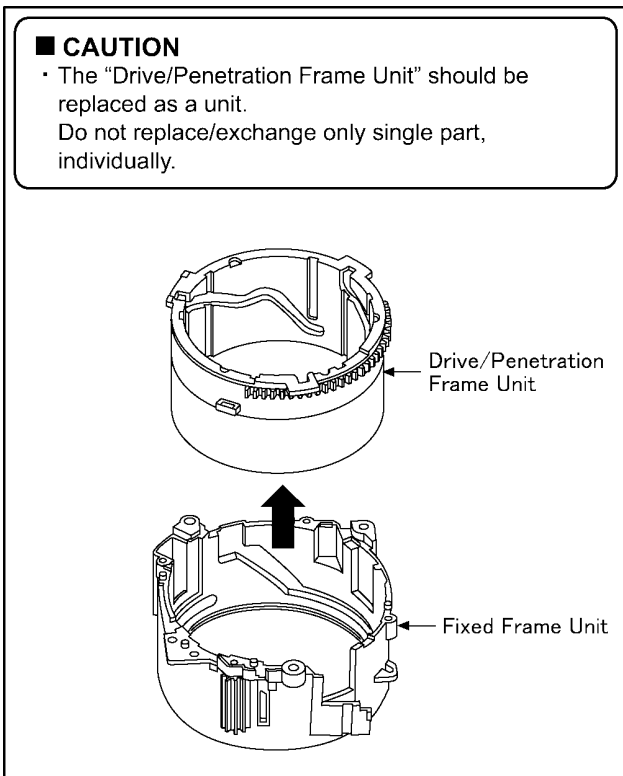

## 8.5. Assembly Procedure for the Lens

### 8.5.1. Phase alignment of the Penetration Cam Frame and Drive Frame Unit

1. Insert the shading sheet to drive frame unit.  
(When insert the shading sheet, so that the luster side facing to subject side.)
2. Set the projection part(most wide) of penetration cam frame at the upper left and the gear part of drive frame unit at the lower right, and then install the penetration cam frame to drive frame unit.

Set the projection part(most wide) at the upper left.

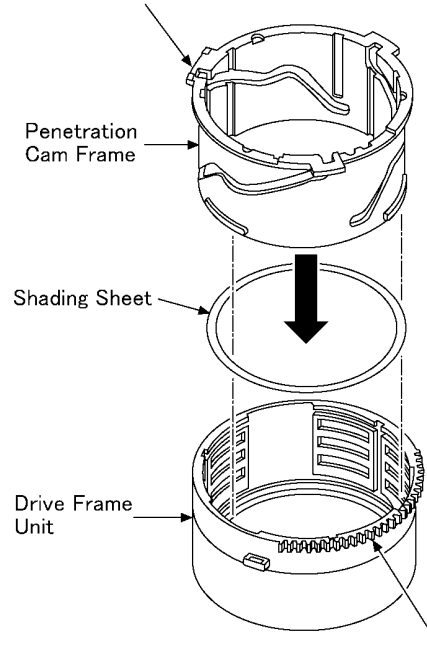

Set the gear part at the lower right.

- Align the phase of the groove of penetration cam frame and the groove of drive frame unit (3 points).

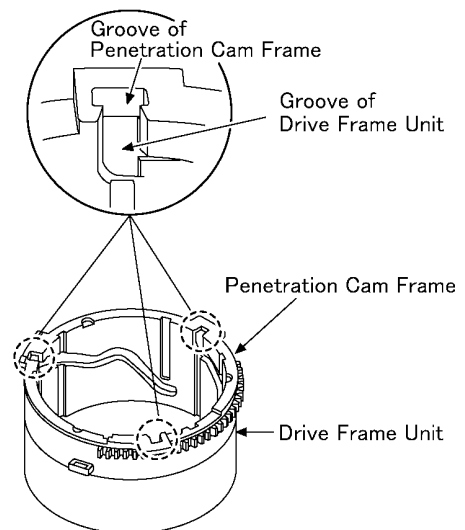



### 8.5.2. Phase alignment of the Drive/Penetration Frame Unit and Fixed Frame Unit

1. Align the projection part(most wide) of drive/penetration frame unit and the flex insert part of fixed frame unit.
2. Align the convex part of drive/penetration frame unit and the groove of fixed frame unit, and then install the drive/penetration frame unit to fixed frame unit.

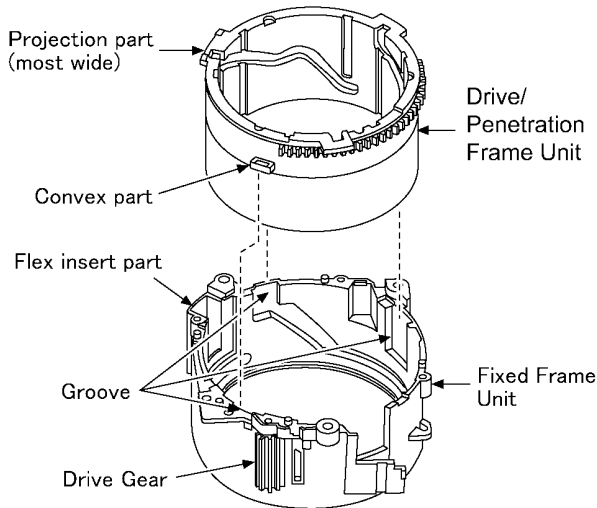

**NOTE: (When Installing)**

- With aligning the phase of the drive/penetration frame unit and the fixed frame unit, confirm the gear of drive frame unit is engaged with the gear of fixed frame unit firmly.

### 8.5.3. Phase alignment of the 2nd Lens Frame Unit and Both Sides Cam Frame

1. Set the No. mark of 2nd lens frame unit at the upper side and the concave part(most large) of both sides cam frame at the left.
2. Align the convex of 2nd lens frame unit and the groove of both sides cam frame, and then install the 2nd lens frame unit to both sides cam frame.

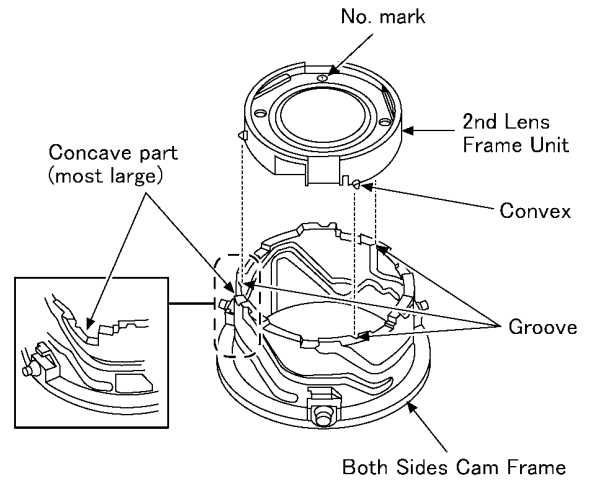

**NOTE: (When Installing)**

- Take care not to put fingerprint of the lens.

### 8.5.4. Phase alignment of the 3rd Lens Frame Unit and 2nd Lens Frame Unit/Both Sides Cam Frame

1. Set the concave part(flex side) of 3rd lens frame unit at the upper side and the concave(most large) of 2nd lens frame unit/both sides cam frame at the right.
2. Align the convex of 3rd lens frame unit and the groove of 2nd lens frame unit/both sides cam frame, and then install the 3rd lens frame unit to 2nd lens frame unit/both sides cam frame.

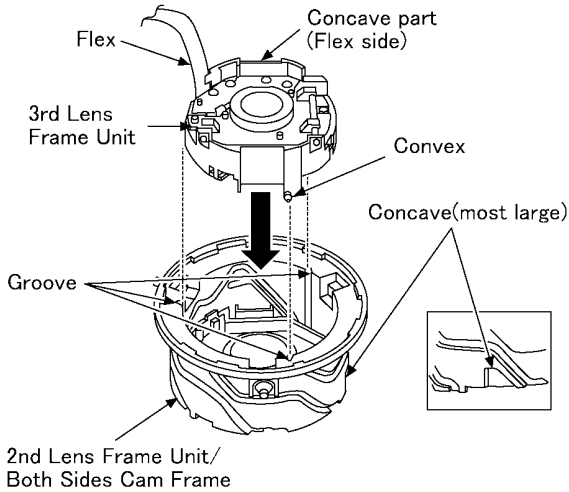

**NOTE: (When Installing)**

- Take care not to put fingerprint of the lens.
- Take care not to damage the flex.

### 8.5.5. Phase alignment of the 2nd 3rd Direct Frame and 2nd Lens Frame Unit/Both Sides Cam Frame/3rd Lens Frame Unit

- Align the projection part(curved) of 2nd 3rd direct frame and the concave part(flex side) of 2nd lens frame unit/both sides cam frame/3rd lens frame unit, and then install the 2nd 3rd direct frame to 2nd lens frame unit/both sides cam frame/3rd lens frame unit.

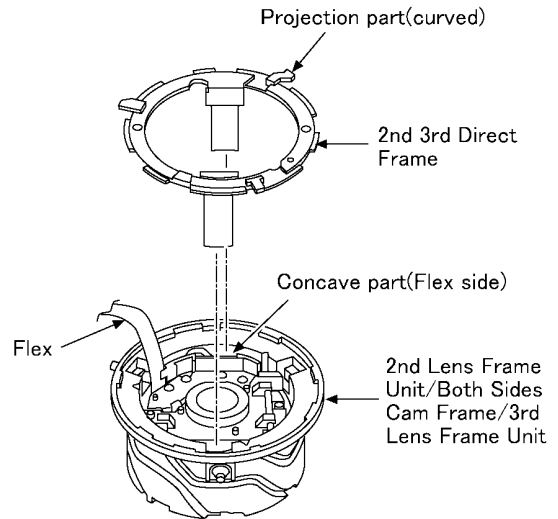

**NOTE: (When Installing)**

- Take care not to put fingerprint of the lens.

### 8.5.6. Phase alignment of the 2nd Lens Frame Unit/Both Sides Cam Frame/2nd 3rd Direct Frame/3rd Lens Frame Unit and 1st Lens Frame Unit

1. Set the flex part of 2nd lens frame unit/both sides cam frame/2nd 3rd direct frame/3rd lens frame unit at the upper side.

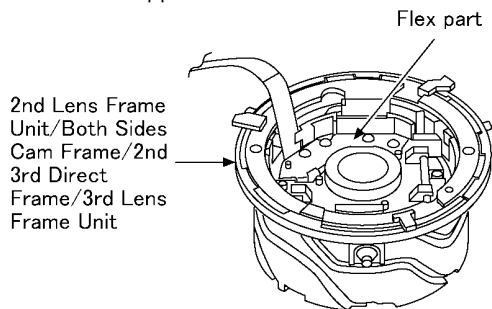

2. Rotate the 2nd lens frame unit/both sides cam frame/2nd 3rd direct frame/3rd lens frame unit in a clockwise direction approx. 110 degrees.

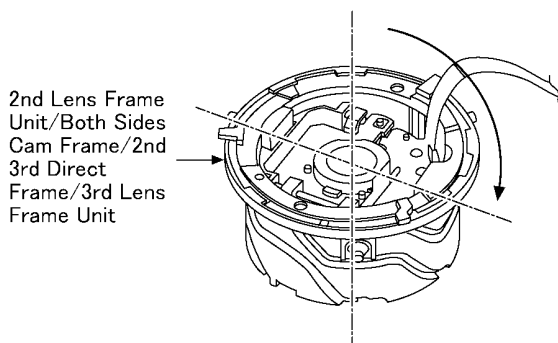

3. Set the "LEICA" character on the front side of 1st lens frame unit at the upper side.
4. Align the groove of 2nd lens frame unit/both sides cam frame/2nd 3rd direct frame/3rd lens frame unit and the convex of 1st lens frame unit, and then install the 2nd lens frame unit/both sides cam frame/2nd 3rd direct frame/3rd lens frame unit to 1st lens frame unit. (The 2nd lens frame unit/both sides cam frame/2nd 3rd direct frame/3rd lens frame unit rotates in a counterclockwise direction while installing.)

2nd Lens Frame Unit/Both Sides Cam Frame/2nd 3rd Direct Frame/3rd Lens Frame Unit

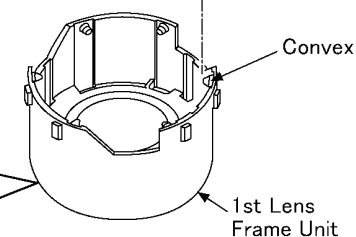
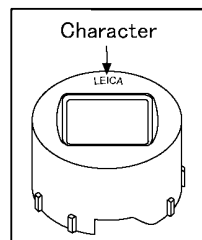
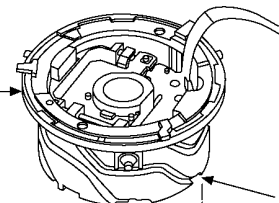

5. The flex part of 2nd lens frame unit/both sides cam frame/2nd 3rd direct frame/3rd lens frame unit is seen at the upper side when install is finished.

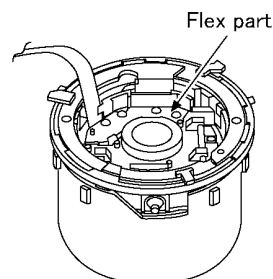

#### NOTE: (When Installing)

- Take care not to put fingerprint of the lens.
- Take care not to damage the flex.

**8.5.7. Phase alignment of the 1st Lens Frame Unit/2nd Lens Frame Unit/ Both Sides Cam Frame/2nd 3rd Direct Frame/3rd Lens Frame Unit and 1st Direct Frame Unit**

1. Set the flex part of 1st lens frame unit/2nd lens frame unit/both sides cam frame/2nd 3rd direct frame/3rd lens frame unit at the upper side and the projection part(most wide) of 1st direct frame unit at the upper left side.
2. Align the convex part of 1st lens frame unit/2nd lens frame unit/both sides cam frame/2nd 3rd direct frame /3rd lens frame unit and the groove of 1st direct frame unit, and then install the 1st lens frame unit/ 2nd lens frame unit/both sides cam frame/2nd 3rd direct frame/3rd lens frame unit to 1st direct frame unit.

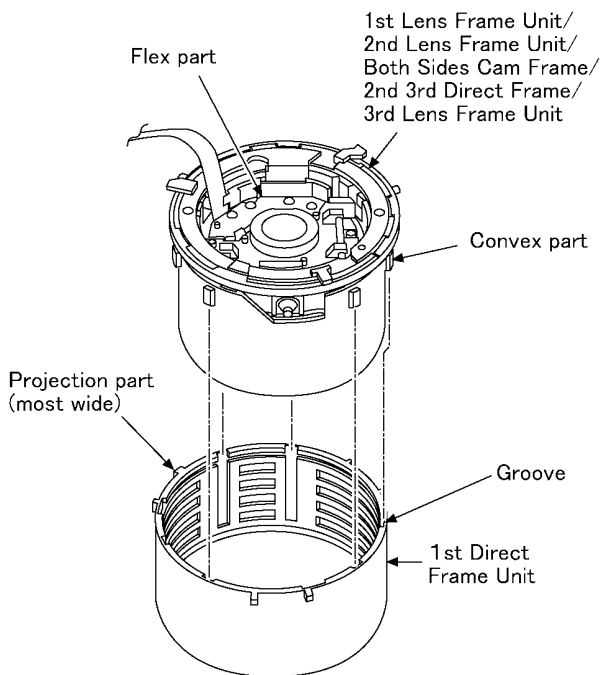

**NOTE: (When Installing)**

- Take care not to put fingerprint of the lens.
- Take care not to damage the flex.

**8.5.8. Phase alignment of the 1st Direct Frame Unit/1st Lens Frame Unit/ 2nd Lens Frame Unit/Both Sides Cam Frame/2nd 3rd Direct Frame/ 3rd Lens Frame Unit and Fixed Frame Unit/Drive Frame Unit/Pene- tration Cam Frame**

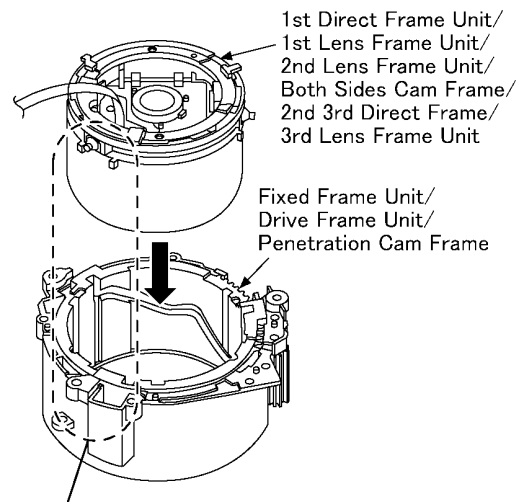

- Insert the convex(1), convex(2) and convex(3) to grooves(a,b,c) in order.

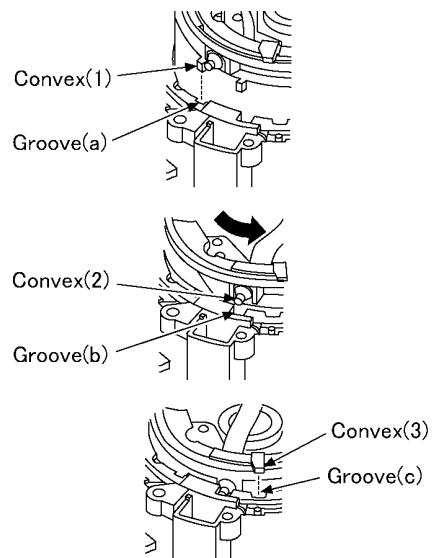

**FRONT VIEW**

- Install the 1st lens frame unit so that the "LEICA" character may become the position of the figure below.

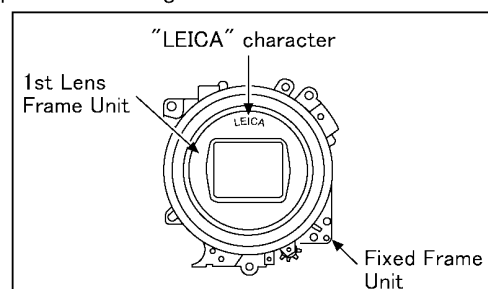

### 8.5.9. Install of the Master Flange Unit

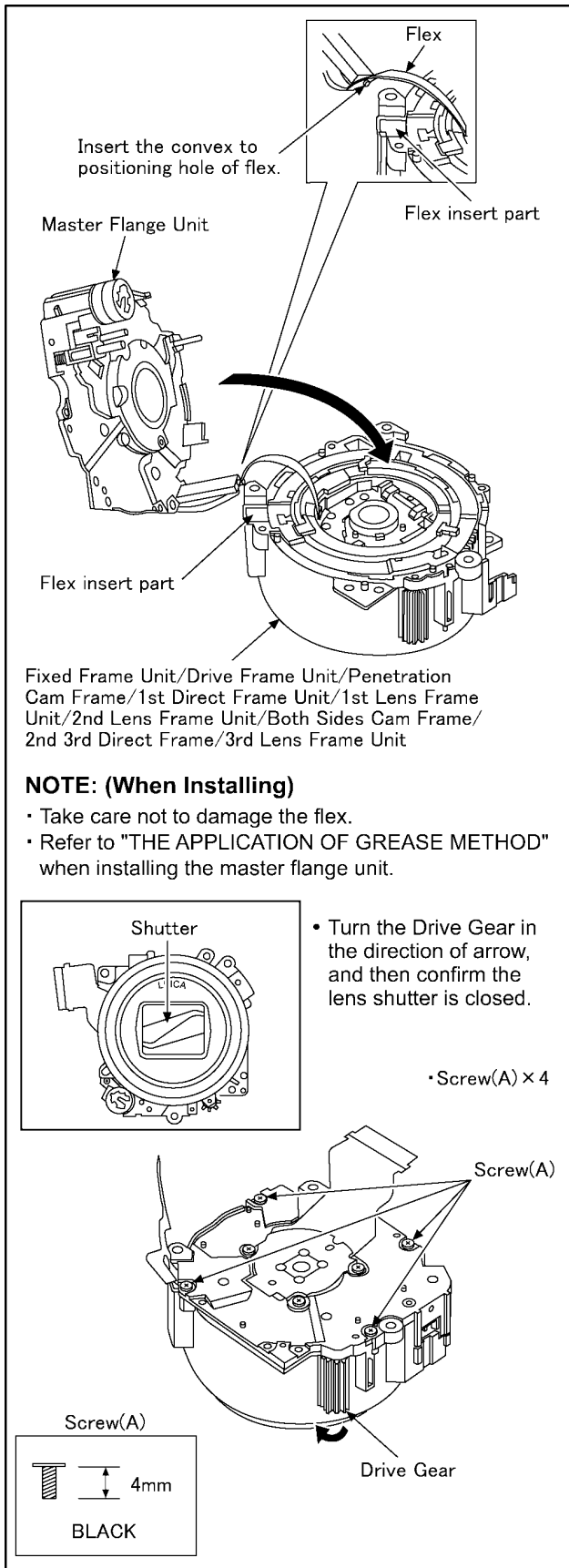

### 8.5.10. Install of the Lens FPC Unit and Zoom Motor

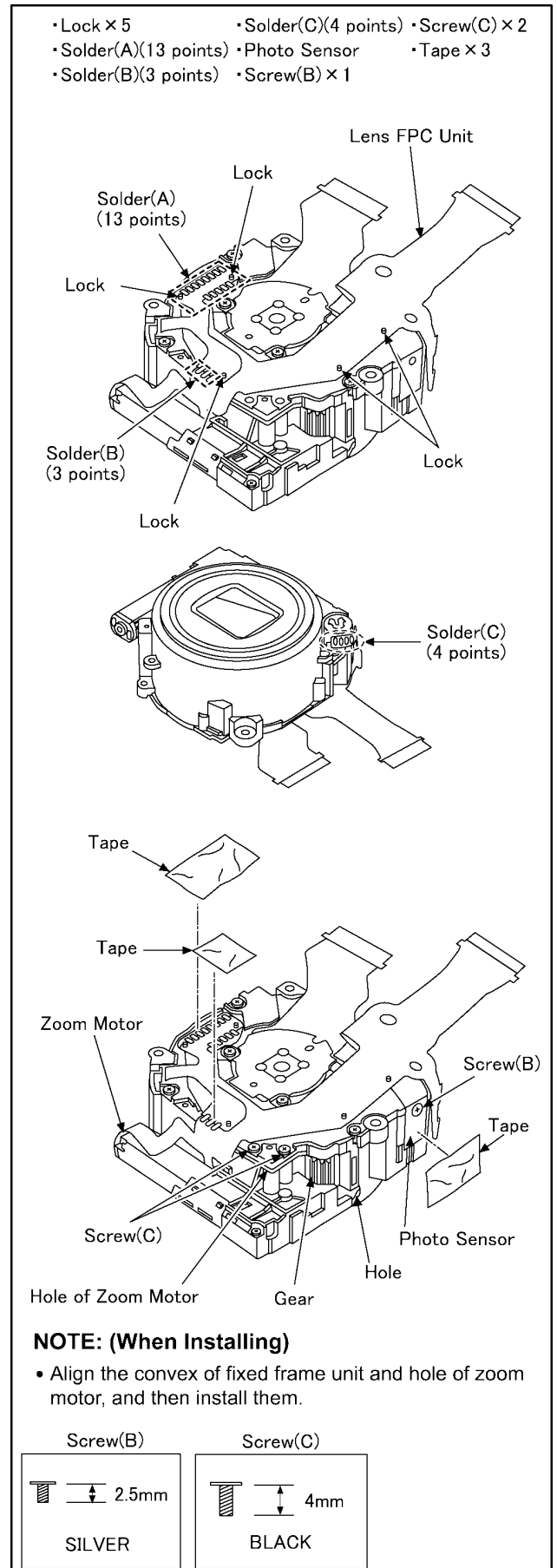

## 8.6. Removal of the CCD Unit

To prevent the CCD unit from catching the dust and dirt, do not remove the CCD unit except for replacing.

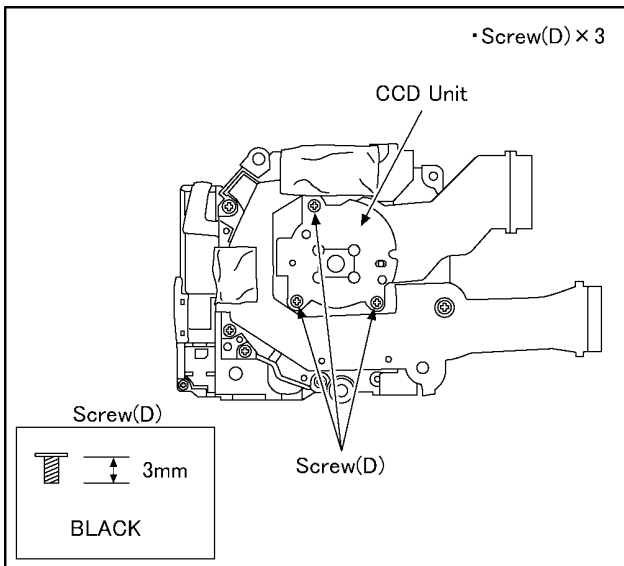

## 8.7. Removal of the Focus Motor

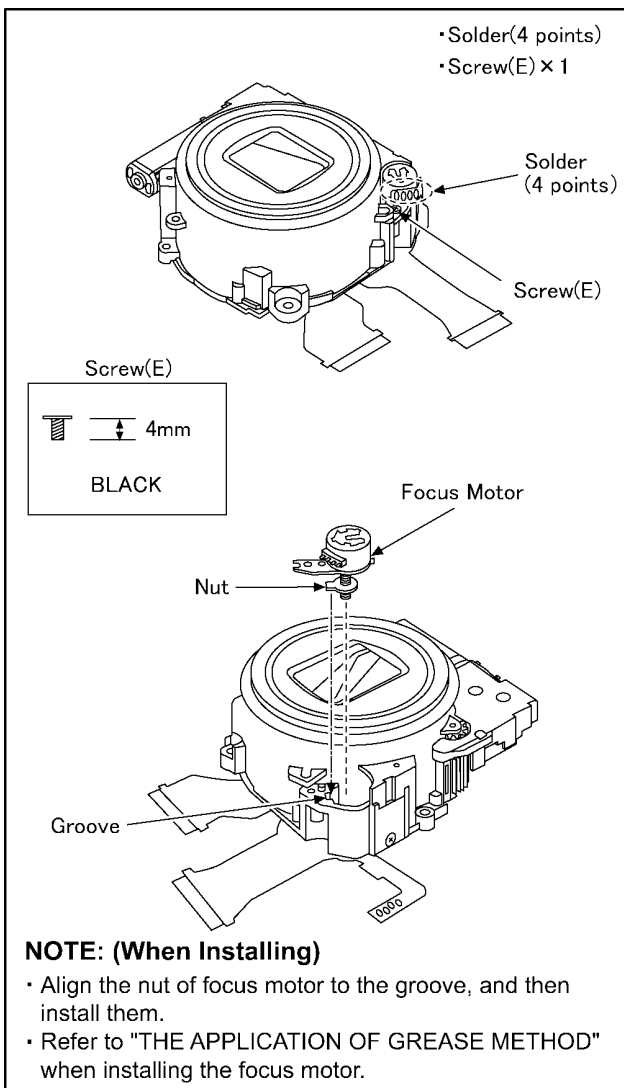

## 8.8. The Application of Grease Method

The grease application parts of lens unit are as follows. Apply grease additionally in the specified position if necessary. When the grease is applied, use a toothpick and apply thinly.

- Focus motor (lead screw)/Fasten groove of nut/Guide pole
  - Grease: RFKZ0472
  - Amount of application: 2 - 4 mg
- Positioning pole
  - Grease: RFKZ0472
  - Amount of application: 1 - 2 mg

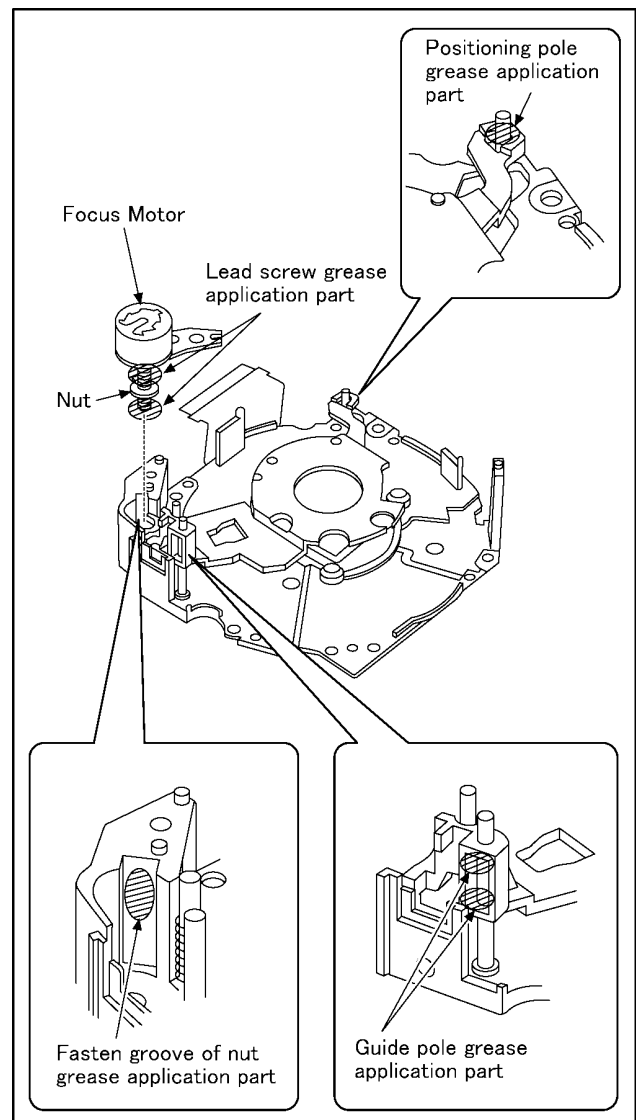

# 9 Measurements and Adjustments

## 9.1. Introduction

When servicing this unit, make sure to perform the adjustments necessary based on the part(s) replaced. Before disassembling the unit, it is recommended to back up the camera data stored in flash-rom as a data file.

### **IMPORTANT NOTICE (After replacing the MAIN P.C.B.)**

After replacing the MAIN P.C.B., it is necessary to use the "DIAS" software to allow the release of adjustment flag(s).

The Adjustment software "DIAS" is available at "TSN Website". To download, click on "Support Information from NWBG/VDBG-AVC".

\*DIAS (DSC Integrated Assist Software)

## 9.2. Before Disassembling the unit

### 9.2.1. Initial Setting Release

The cameras specification are initially set in accordance with model suffix (such as EB, EG, GK, GC, and so on.).

Unless the initial setting is not released, an automatic alignment software in the camera is not able to be executed when the alignment is carried out.

#### **Note:**

The initial setting should be again done after completing the alignment. Otherwise, the camera may not work properly.

Therefore as a warning, the camera display a warning symbol "!" on the LCD monitor every time the camera is turned off.

Refer to the procedure described in "3.4.2 INITIAL SETTINGS" for details.

#### **[ How to Release the camera initial setting ]**

##### **Preparation:**

- Attach the Battery or AC Adaptor with a DC coupler to the unit.

(Since this unit has built-in memory, it can be performed without inserting SD memory card.)

1. Turn the Power on.
2. Press the [ MODE ] button, and select the [ NORMAL PICTURE ] mode by Cursor buttons, then press the [ MENU/SET ] button.
3. Turn the Power off. (If the unit is other than [ NORMAL PICTURE ] mode, it does not display the initial settings menu.)

##### **Step 1. Temporary cancellation of "INITIAL SETTINGS":**

Set the [ REC ]/[ PLAYBACK ] selector switch to "[ REC ] (Camera mark)".

While pressing "[ UP ] of Cursor button" and [ E.ZOOM ] button simultaneously, turn the Power on.

##### **Step 2. Cancellation of "INITIAL SETTINGS":**

Set the [ REC ]/[ PLAYBACK ] selector switch to "[ PLAYBACK ]".

Press "[ UP ] of Cursor button" and [ E.ZOOM ] button simultaneously, then turn the Power off.

The LCD displays the "!" mark before the unit powers down.



## 9.2.2. Flash-Rom Data Backup

When trouble occurs, it is recommended to backup the Flash-rom data before disassembling the unit.

There are two kinds of Flash-rom data backup methods:

### [ ROM\_BACKUP (Method of Non-PC backup) ]

1. Insert the SD-card into the camera.
2. Set the camera to "Temporary cancellation of the initial settings".
3. Select the "SETUP" menu.

From the "SETUP" menu, select "ROM BACKUP".

#### NOTE:

This item is not listed on the customer's "SETUP" menu.

4. When this "ROM\_BACKUP" item is selected, the following submenus are displayed.

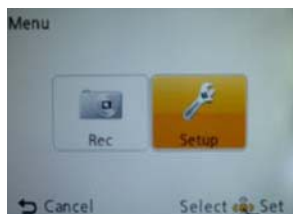

Fig.2-1

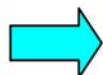

Fig.2-2

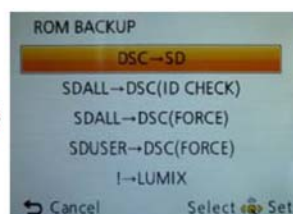
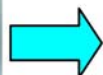

Fig.2-3

Item	Function	Details
DSC → SD	Save all the DSC's Flash-rom data to SD-CARD	*DSC's Flash-rom data is saved to the SD-CARD as a data file by the same format as the TATSUJIN software for the previous models. (DATA BACKUP) -File location: ROOT DIRECTORY in SD-CARD. -File Name: 1) User Setup Information data: <Model Number>U.txt [Example: DMC-FX66 : "FX66U.txt"] 2) Optical Adjustment data: <Model Number>F.txt [Example: DMC-FX66 : "FX66F.txt"] *If the concerned file already exists, "OVERWRITE?" message is displayed.
SDALL→ DSC (ID CHECK)	Write the all data to DSC's Flash-rom from SD-CARD	*The backup data being stored in the SD card is transferred to DSC unit. *ID CHECK: When the model ID is different, data is not transferred.
SDALL→ DSC (FORCE)	Write the all data to DSC's Flash-rom from SD-CARD	*FORCE: Even if the model ID is different, data is transferred. ※If the main PCB is replaced, select "SDALL → DSC (FORCE)".
SDUSER→DSC (FORCE)	Only "User setup information" is written from the saved file in the SD-CARD to DSC's Flash-rom.	*Only the user's "setup" setting condition is transferred to DSC unit. *FORCE: Even if the model ID is different, the data is transferred.
!→LUMIX	Shipping set without initializing "User setup information"	*Initial setting is executed without initializing the user's set up setting condition. ※ The initial setting must be perform while the Self-timer LED is blinking, ※ The picture data stored in the built-in memory of the DSC is not erased, with this operation.

### [ DSC Integrated Assist Software (Method of Using PC) ]

Same as TATSUJIN software for previous models.

## 9.2.3. Light Box

If using VFK1164TDVLB Light Box, remove the lens connection ring by loosening three hexagon screws.

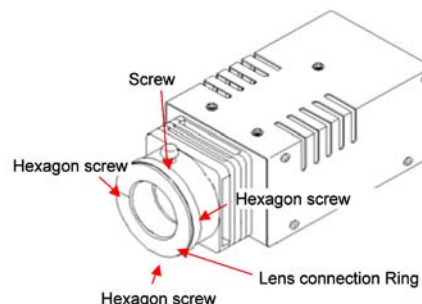



## 9.3. Details of Electrical Adjustment

### 9.3.1. How to execute the Electrical Adjustment

It is not necessary to connect the camera to a PC to perform adjustments.

“Flag reset operation” and “Initial setting operation” are required when carrying out the alignment, follow the procedure below.

#### 9.3.1.1. Startup Electrical Adjustment mode

1. Release the initial settings.
2. Insert a recordable SD card.  
(Without a SD card, the automatic adjustment can not executed.)
3. Procedure to set the camera into adjustment mode:
  - a. Turn the Power on.
  - b. Press the [ MODE ] button, and select the [ NORMAL PICTURE ] mode by Cursor buttons, then press the [ MENU/SET ] button.
  - c. Turn the Power off.
  - d. Turn the Power on pressing [ MENU/SET ] and [ E.ZOOM ] button simultaneously.  
LCD monitor displays “SERVICE MODE”. (Refer to Fig. 3-1)

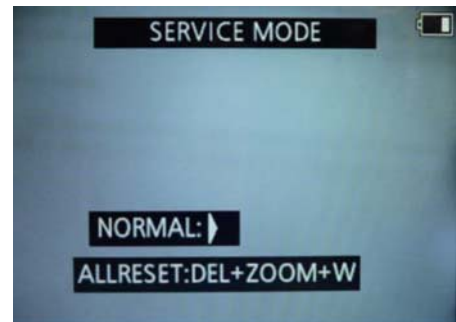

Fig.3-1

#### 9.3.1.2. Status Adjustment Flag Setting

Reset (Not yet adjusted) the status flag condition.

1. After pressing the [ DISP. ] button”, the LCD monitor displays the Flag status screen (Refer to Fig.3-2)
2. Select item by pressing the Cursor buttons. (Gray cursor is moved accordingly.)
3. Press the [ Delete ] button.

**NOTE:**

The selected item's flag has been changed from “F (green)” to “0 (yellow)”.

\*Flag conditions:

F (green)

means that the alignment has been completed and the status flag condition is set. In this case, the flag condition should be reset, if you try to carry out the automatic alignment.

0 (yellow)

means that the alignment has been not “completed” and the status flag condition is “reset”. In this case, automatic alignment is available.

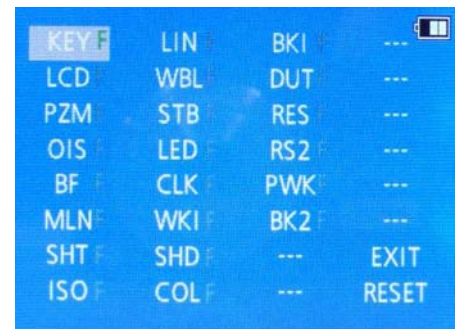

Fig.3-2

- In case of setting the status flag into set condition again without completion of the alignment, the status flag should be SET by using PC, or UNDO by using ROM BACKUP function.

### 9.3.1.3. Execute Adjustment (In case of “OIS Adjustment”)

1. Perform step “9.3.1.1.” to “9.3.1.2.”, to reset the OIS flag status “F” (Set) to “0” (Reset)
2. Press [ DISP. ] button after Flag reset.  
OIS Adjustment screen is displayed on the LCD panel.  
(Refer to Fig.3-3)
3. Press the [ Shutter ] button. The adjustment will start automatically.



Fig.3-3

4. When the adjustment is completed successfully, adjustment report menu appears with Green OK on the LCD monitor. (Refer to Fig.3-4)

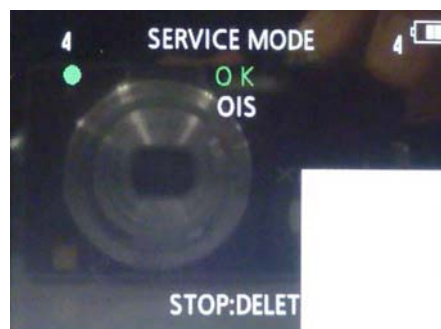

Fig.3-4

### 9.3.1.4. Attention point during Adjustment

1. Step “9.3.1.3.” procedure shows OIS adjustment as an example. To perform the adjustment, refer to the “9.3.2. Adjustment Specifications” table which shows key point for each adjustment.
2. Do not move the light box, the camera or the chart while adjusting. If one of these is moved accidentally, start the adjustment again.
3. Do not press any buttons/keys until the default menu (Fig.3-5) is displayed on the LCD monitor. Otherwise, adjustment data may not be stored properly.
4. If the adjustment is interrupted accidentally, the alignment data may not be properly saved in the Flash-rom.

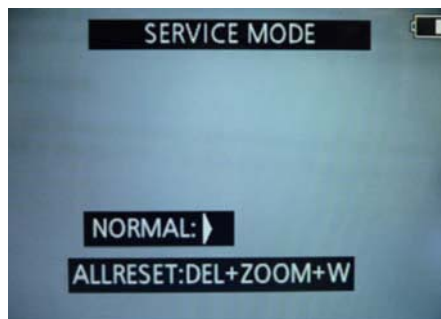

Fig.3-5

### 9.3.1.5. Finalizing the Adjustment

1. Several adjustment flags can be reset (“F” into “0”) at the same time. In this case, when the adjustment has been completed, the screen will change showing the adjustment for the next item until all reset items are completed.  
Also, when the shutter button is pressed, the screen jump to the next adjustment item.
2. To cancel the adjustment mode while in the process of performing the adjustment, follow this procedures.  
(1) Press “[ RIGHT ] of cursor button”.

#### NOTE:

- If adjustment is cancelled with above procedure, adjustment is not completed. Make sure to adjust it later.
- Adjustment software “DIAS” is able to control the status of the adjustment flags.

### 9.3.2. Adjustment Specifications

The following matrix table shows the relation between the replaced part and the Necessary Adjustment.

When a part is replaced, make sure to perform the necessary adjustment(s) in the order indicated.

The table below shows all the information necessary to perform each adjustment.

Adjustment order	Adjustment Item	FLAG	Purpose	Replacing Parts						JIG/TOOLS	SET UP	How to Operate	
				MAIN PCB	VENUS (IC6001)	MCP (IC6002)	Lens Parts (except CCD)	CCD Unit	GYRO (IC7101)				LCD unit
1	LCD flickering	LCD	Minimize the LCD flickering	○	—	○	—	—	—	○	NONE	NONE	1)No flickering, just press the shutter Button. 2)There are four LCD mode. (The position of green ●mark is different.) Select LCD modes with less flicking by pressing the left/right cursor buttons. Then press the shutter button.
2	Venus Zoom	PZM	Venus Zoom Inspection	○	○	○	—	○	—	—	NONE	NONE	1)Press Shutter Button 2)After displaying "PZM", press Shutter Button again. 3)After completed, the"OK" message appears.
3	OIS sensor	OIS	OIS sensor output level adjustment	○	○	○	○	○	—	—	NONE	NONE	1)Press Shutter Button (Do not apply any shock and vibration for the camera while adjusting) 2)After completed, the"OK" message appears.
4	Backfocus / GYRO	BF	To have the focus tracking curve be appropriate shape and GYRO sensor adjustment	○	○	○	○	○ ※1	—	○	-COLLIMATOR (VFK1164TCM02 or VFK1164TCM03 or RFKZ0422)	1)Set the camera in front of collimator so that the distance between collimator and camera becomes about 4 cm as shown in Fig.A. 【NOTE】 Please note that "NG" might happen while auto adjusting. - Do not put the black colored stuff at the back side of collimator near hunching chart to get some certain brightness. - Make sure the hunting chart has no dust and dirty condition. - Not connect the USB cable at this stage.	1)Press Shutter Button (Do not apply any shock and vibration for the camera while adjusting) 2)After completed, the"OK" message appears.
5	Monitor Linearity	MLN	Monitor Linearity adjustment	○	○	○	○	○	—	—		1)Set the camera in front of LIGHTBOX so that the distance between collimator and camera becomes about 4 cm as shown in Fig.B.	1)Press Shutter Button 2)After completed, the "OK" message appears.
6	Shutter	SHT	Shutter speed adjustment	○	○	○	○	○	—	—		1) Insert the TR chart into the slot of LIGHTBOX. 2) Set the camera in front of LIGHTBOX so that the distance between LIGHTBOX and camera becomes about 15 cm as shown in FigB.	1)Press Shutter Button 2)After completed, the "OK" message appears.
7	ISO	ISO	ISO sensitivity adjustment	○	○	○	○	○	—	—	-LIGHT BOX (RFKZ0523 (VFK1164TDVLB) -TR CHART (RFKZ0443)	3) Set the camera angle so that the color chart is displayed on the LCD monitor fully. 【NOTE】 - Since the lens position is automatically set into certain position after executing auto adjustment, confirm the angle after stopping the lens zoom position. - It is no problem even though the chart on to the LCD monitor slightly cut at the corner. - It is no problem even though the focusing slightly becomes out of focusing condition. - Not connect the USB cable at this stage.	1)Press Shutter Button 2)After completed, the "OK" message appears.
8	High brightness coloration	LIN	High brightness coloration adjustment	○	○	○	○	○	—	—			1)Press Shutter Button 2)After completed, the "OK" message appears.
9	White Balance	WBL	White balance adjustment under various color temperature	○	○	○	○	○	—	—			1)Press Shutter Button 2)After completed, the "OK" message appears.
10	CCD Missing Pixels (White)	WKI	Compensation of CCD Missing Pixels (White)	○	○	○	—	○ ※1	—	—	NONE	NONE	1)Press Shutter Button 2)After completed, the "OK" message appears.
11	Color reproduction inspection and Microphone check	COL	Color reproduction inspection and Microphone check	○	○	○	○	○	—	—	NONE	NONE	1)Press Shutter Button 2)After completed, the "OK" message appears.
		BKI	Do not use "BKI" adjustment flag for this unit. Use "BK2" adjustment flag, instead. (In case of mostDSC models, the adjustment flag for CCD Missing Pixcels is "BKI". But, in this model, "BK2" the adjustment flag for CCD Missing Pixcels.)										

Adjustment order	Adjustment Item	FLAG	Purpose	Replacing Parts						JIG/TOOLS	SET UP	How to Operate
				MAIN PCB	VENUS (IC6001)	MCP (IC6002)	Lens Parts (except CCD)	CCD Unit	GYRO (IC7101)			
12	CCD Missing Pixels (Black)	BK2	Compensation of CCD Missing Pixels (Black)	○	○	○	—	○ ※1	—	—	<p>•LIGHT BOX RFKZ0523 (VFK1164TDVLB) •ND FILTER (VFK1164ND15)</p> <p>1) Prepare the LIGHTBOX (RFKZ0523). (The LIGHTBOX "VFK1164TDVLB" can be used if the front hood of VFK1164TDVLB is removed.) 2) Set the ND Filter (VFK1164ND15) to the LIGHTBOX. 3) Set the LIGHTBOX and Camera unit so that distance becomes about 4 cm.</p> <p><b>NOTE:</b> Do not use "BK1" adjustment flag for this unit. Use "BK2" adjustment flag, instead.</p>	<p>1) Press Shutter Button. (The lens starts zooming and stops automatically, then green ● mark is displayed on LCD). 2) Aim the LIGHTBOX so that the entire LCD screen becomes fully "white". (No dark area). 3) Press Shutter Button. (The &lt;BK1 adjustment 1&gt; is executed, and then green ● mark is displayed on LCD). 4) Press Shutter Button. (The lens starts zooming and stops automatically, then green ● mark is displayed on LCD). 5) Press Shutter Button. (The &lt;BK1 adjustment 2&gt; is executed, and then green ● mark is displayed on LCD). 6) Press Shutter Button. (The lens starts zooming and stops automatically, then green ● mark is displayed on LCD). 7) Press Shutter Button. (The &lt;BK1 adjustment 3&gt; is executed, and then green ● mark is displayed on LCD). 8) Press Shutter Button. ("OK" mark is displayed on LCD when the adjustment has been completed successfully).</p>

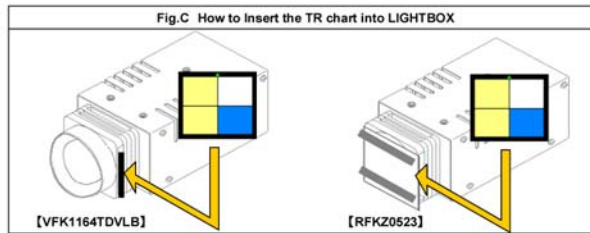
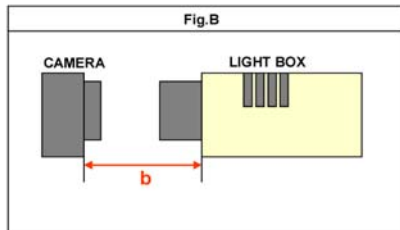
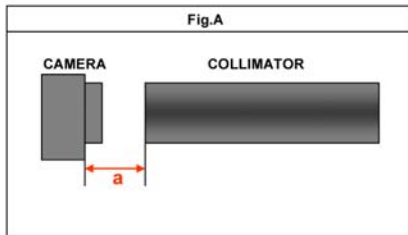

**■ IMPORTANT NOTICE (After replacing the MAIN P.C.B.)**

After replacing the MAIN P.C.B., make sure to perform the "INITIAL SETTINGS" first, then release the "INITIAL SETTINGS" in order to proceed the electrical adjustment.

**NOTE:**

- 1). If electrical adjustment or data re-writing is executed before "INITIAL SETTINGS", suffix code list is never displayed, and it cannot be chosen suitable suffix code.
- 2). Never remove the battery during initial setting in process.

## **9.4. After Adjustment**

### **9.4.1. Initial Setting**

Since the initial setting has been released to execute the built-in adjustment software, it should be set up again before shipping the camera to the customer.

Refer to the procedure described in “3.4.2. INITIAL SETTINGS” for details.

#### **[ IMPORTANT ]**

1. The initial setting should be done again after completing the alignment. Otherwise, the camera will not work properly.  
Therefore as a warning, the camera display a warning symbol “ ! ” on the LCD monitor every time the camera is turned off.
2. Confirm that status of all adjustment flag show “F”. Even if one of the adjustment flag shows “0”, initial setting programmed is never executed.
3. Adjustment software “DIAS” is able to control the status of the adjustment flags.  
The Adjustment software “DIAS” is available at “TSN Website”, therefore, access to “TSN Website” at “Support Information from NWBG/VDBG-AVC”.

# 10 Maintenance

## 10.1. Cleaning Lens and LCD Panel

Do not touch the surface of lens and LCD Panel with your hand.

When cleaning the lens, use air-Blower to blow off the dust.

When cleaning the LCD Panel, dampen the lens cleaning paper with lens cleaner, and the gently wipe the its surface.

**Note:**

The Lens Cleaning KIT ; VFK1900BK (Only supplied as 10 set/Box) is available as Service Aid.

# Service Manual

---

## Diagrams and Replacement Parts List

### Digital Camera

Model No.

DMC-FS35EB	DMC-FH25P	DMC-FH25GF
DMC-FS35EE	DMC-FH25PC	DMC-FH25GH
DMC-FS35EF	DMC-FH25PR	DMC-FH25GK
DMC-FS35EG	DMC-FH25PU	DMC-FH25GN
DMC-FS35EP	DMC-FH25GA	DMC-FH25GT
	DMC-FH25GC	DMC-FH24P

Vol. 1  
Colour

[DMC-FS35]

- (S).....Silver Type (except EF)
- (K).....Black Type
- (R).....Red Type (except EE)
- (A).....Blue Type (except EF)
- (V).....Violet Type (except EE/EF)

[DMC-FH25]

- (S).....Silver Type (except PC/PR/GT)
- (K).....Black Type
- (R).....Red Type (except PR/GT)
- (A).....Blue Type (only P/PC/PU/GK/GN)
- (V).....Violet Type (only P/PC/PR/PU/GT)

[DMC-FH24]

- (K).....Black Type

### Table of contents

S1. About Indication of The Schematic Diagram.....	S-1	S6. Replacement Parts List.....	S-15
S1.1. Important Safety Notice.....	S-1		
S2. Voltage Chart .....	S-2	S7. Exploded View .....	S-20
S2.1. Flash Top P.C.B.....	S-2	S7.1. Frame and Casing Section.....	S-20
S3. Block Diagram.....	S-3	S7.2. Packing Parts and Accessories Section (1) .....	S-21
S3.1. Overall Block Diagram .....	S-3	S7.3. Packing Parts and Accessories Section (2) .....	S-22
S4. Schematic Diagram.....	S-4		
S4.1. Interconnection Diagram .....	S-4		
S4.2. Flash Top Schematic Diagram .....	S-5		
S4.3. CCD Flex Schematic Diagram .....	S-6		
S4.4. Lens Flex Schematic Diagram .....	S-7		
S5. Print Circuit Board.....	S-8		
S5.1. Flash Top P.C.B.....	S-8		
S5.2. CCD Flex P.C.B.....	S-12		
S5.3. Lens Flex P.C.B.....	S-13		

## S1. About Indication of The Schematic Diagram

### S1.1. Important Safety Notice

COMPONENTS IDENTIFIED WITH THE MARK  $\triangle$  HAVE THE SPECIAL CHARACTERISTICS FOR SAFETY. WHEN REPLACING ANY OF THESE COMPONENTS USE ONLY THE SAME TYPE.

1. Although reference number of the parts is indicated on the P.C.B. drawing and/or schematic diagrams, it is NOT mounted on the P.C.B. when it is displayed with "\$" mark.
2. It is only the "Test Round" and no terminal (Pin) is available on the P.C.B. when the TP (Test Point) indicated as "●" mark.
3. The voltage being indicated on the schematic diagram is measured in "Standard-Playback" mode when there is no specify mode is mentioned.
4. Although the voltage and waveform available on here is measured with standard frame, it may be differ from actual measurement due to modification of circuit and so on.
5. The voltage being indicated here may be include observational-error (deviation) due to internal-resistance and/or reactance of equipment. Therefore, handle the value indicated on here as reference.
6. Use the parts number indicated on the Replacement Parts List .
7. Indication on Schematic diagrams:

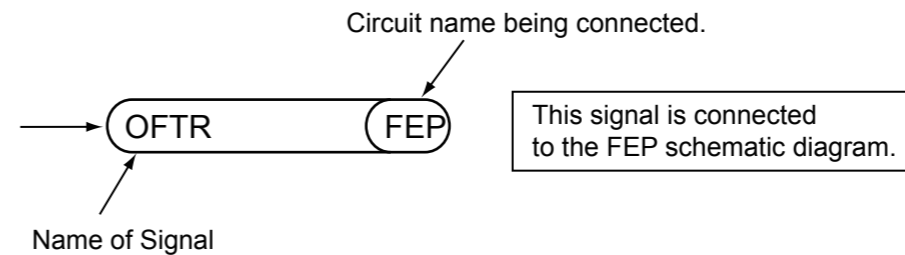

## S2. Voltage Chart

Note) Indicated voltage values are the standard values for the unit measured by the DC electronic circuit tester (high-impedance) with the chassis taken as standard.  
Therefore, there may exist some errors in the voltage values, depending on the internal impedance of the DC circuit tester.

### S2.1. Flash Top P.C.B.

REF No.	PIN No.	POWER ON
IC8100	1	0
IC8100	2	0
IC8100	3	0
IC8100	4	0
IC8100	5	3.4
IC8100	6	0
IC8100	7	0
IC8100	8	0
IC8100	9	3.1
IC8100	10	3.9



# S3. Block Diagram

## S3.1. Overall Block Diagram

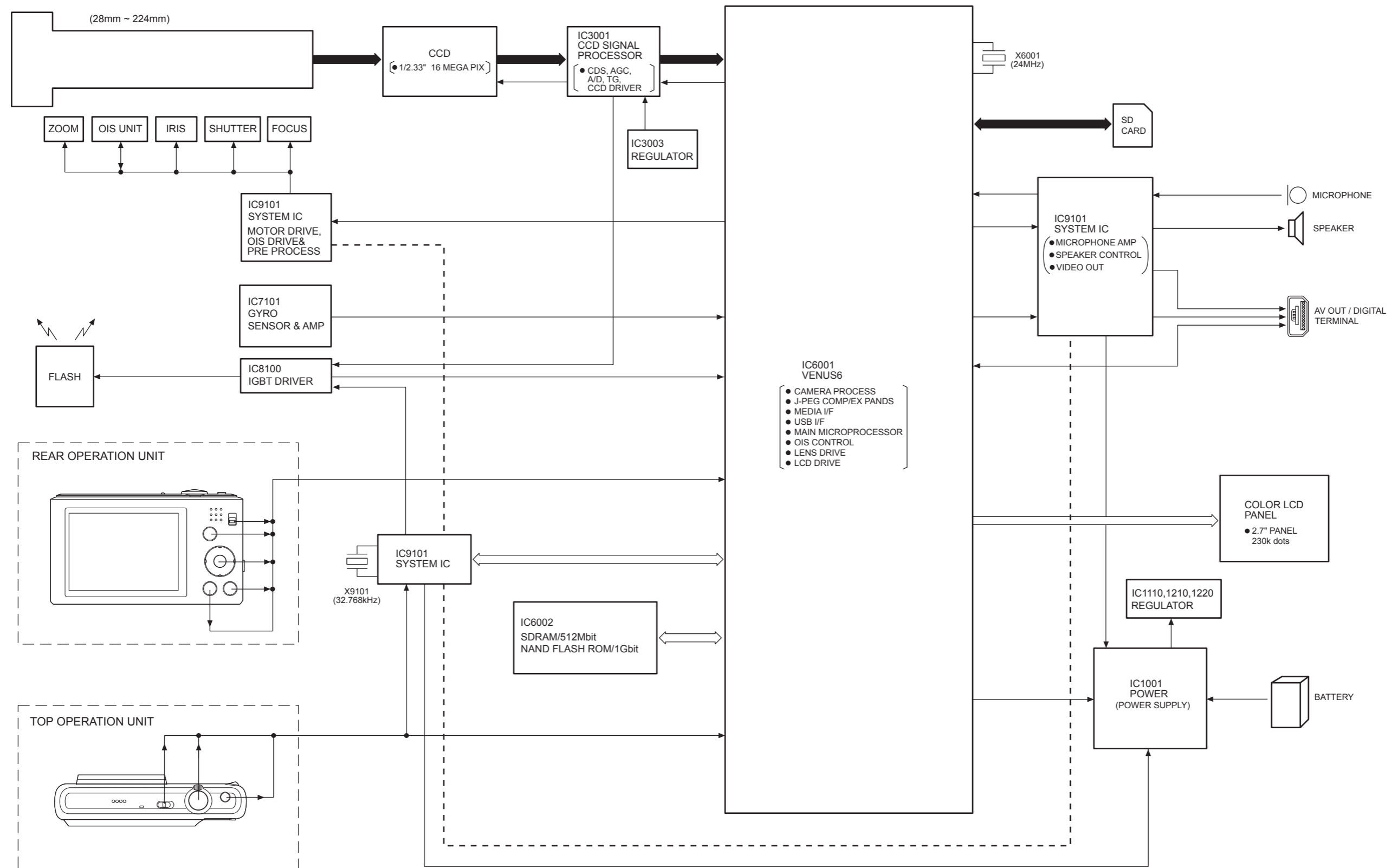

# S4. Schematic Diagram

## S4.1. Interconnection Diagram

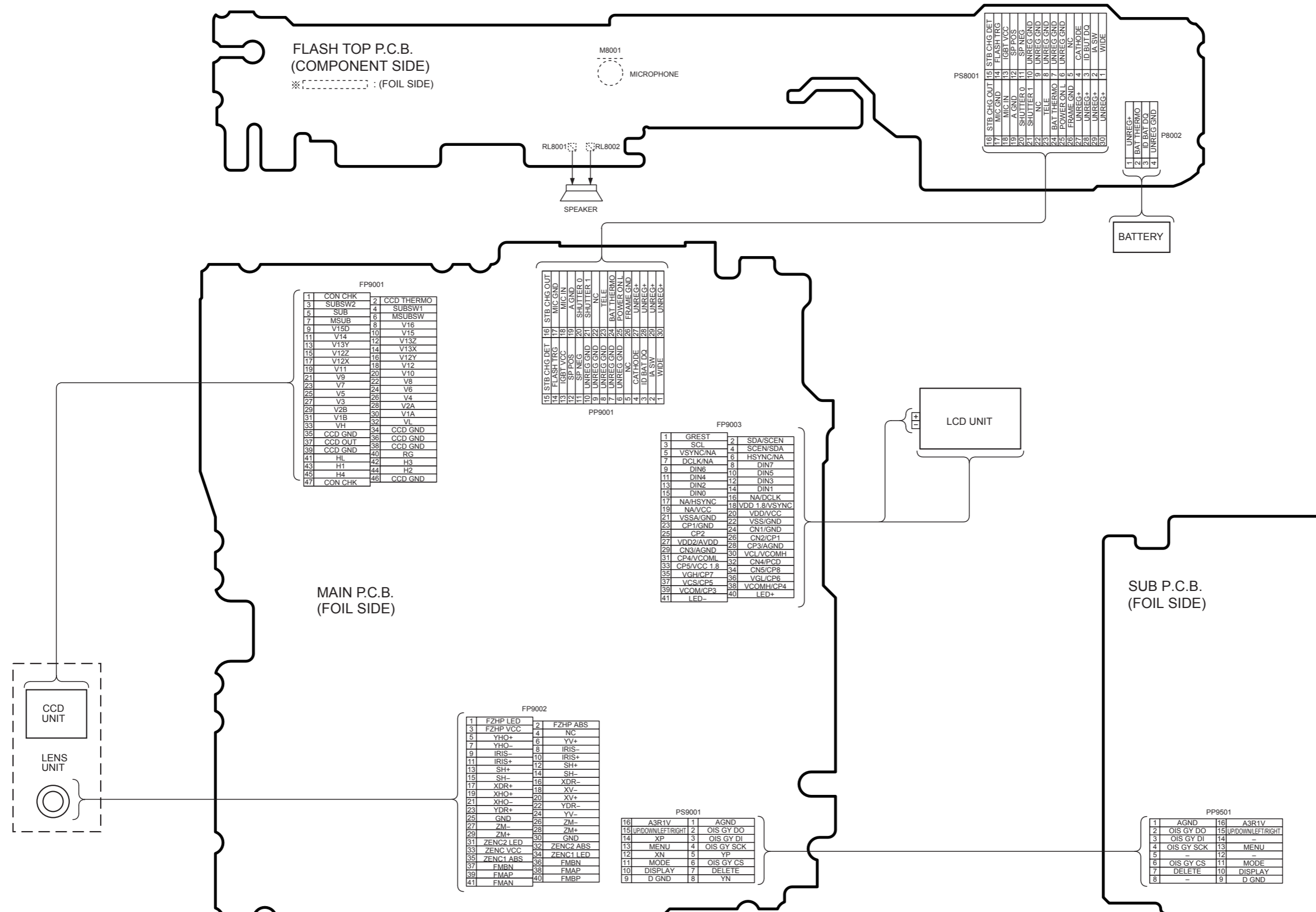

# S4.2. Flash Top Schematic Diagram

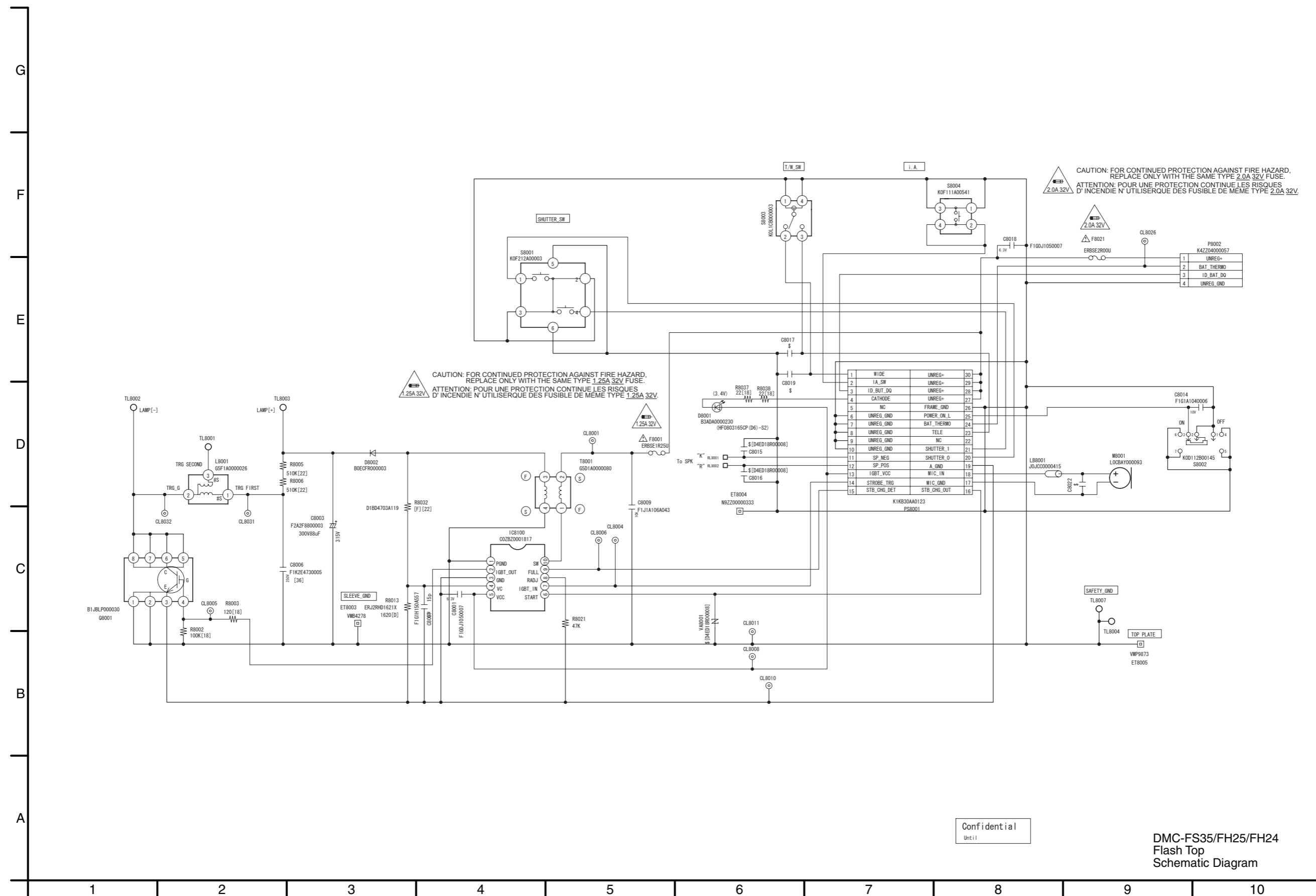

Confidential  
Unit 1

DMC-FS35/FH25/FH24  
Flash Top  
Schematic Diagram

### S4.3. CCD Flex Schematic Diagram

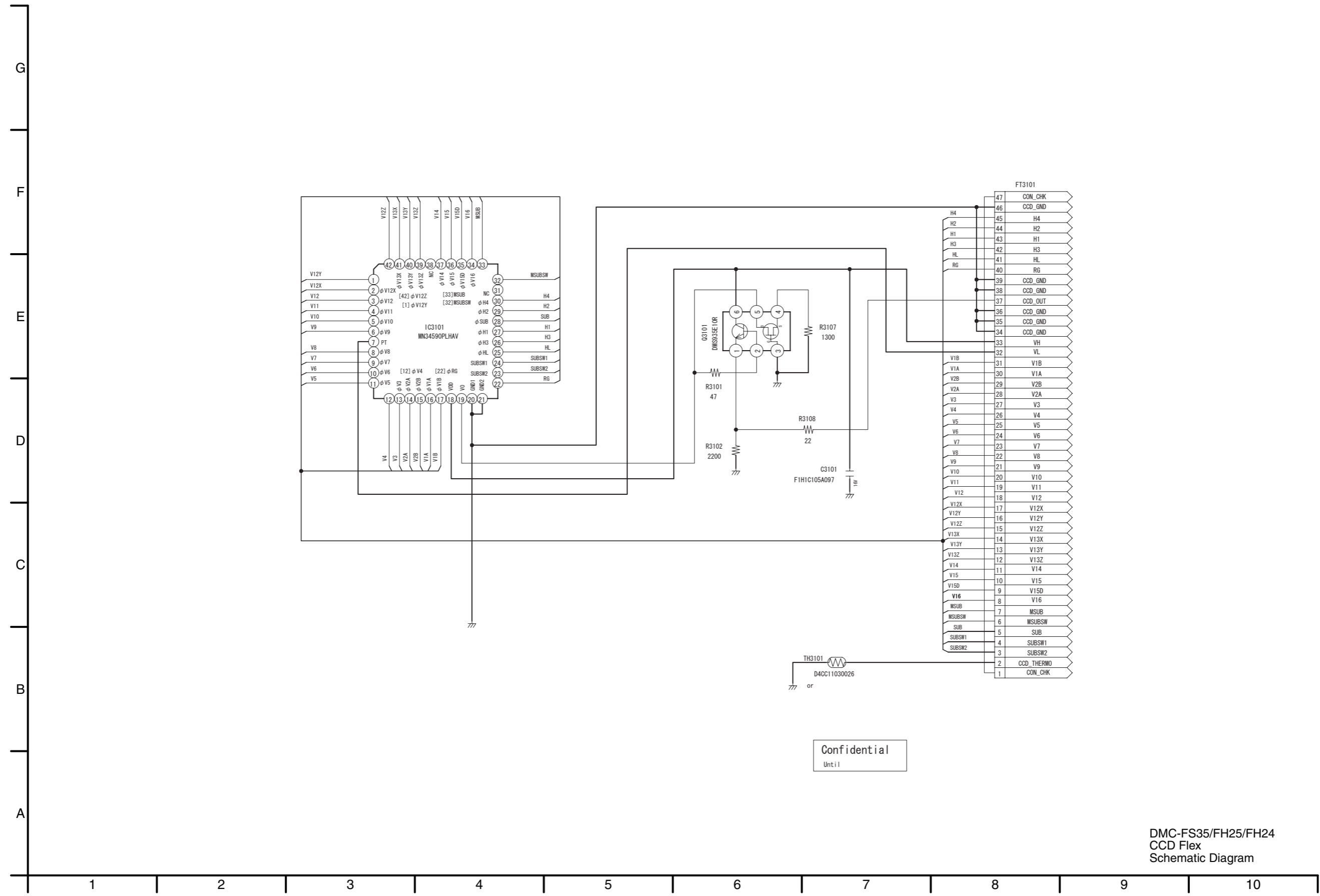

Confidential  
Until

# S4.4. Lens Flex Schematic Diagram

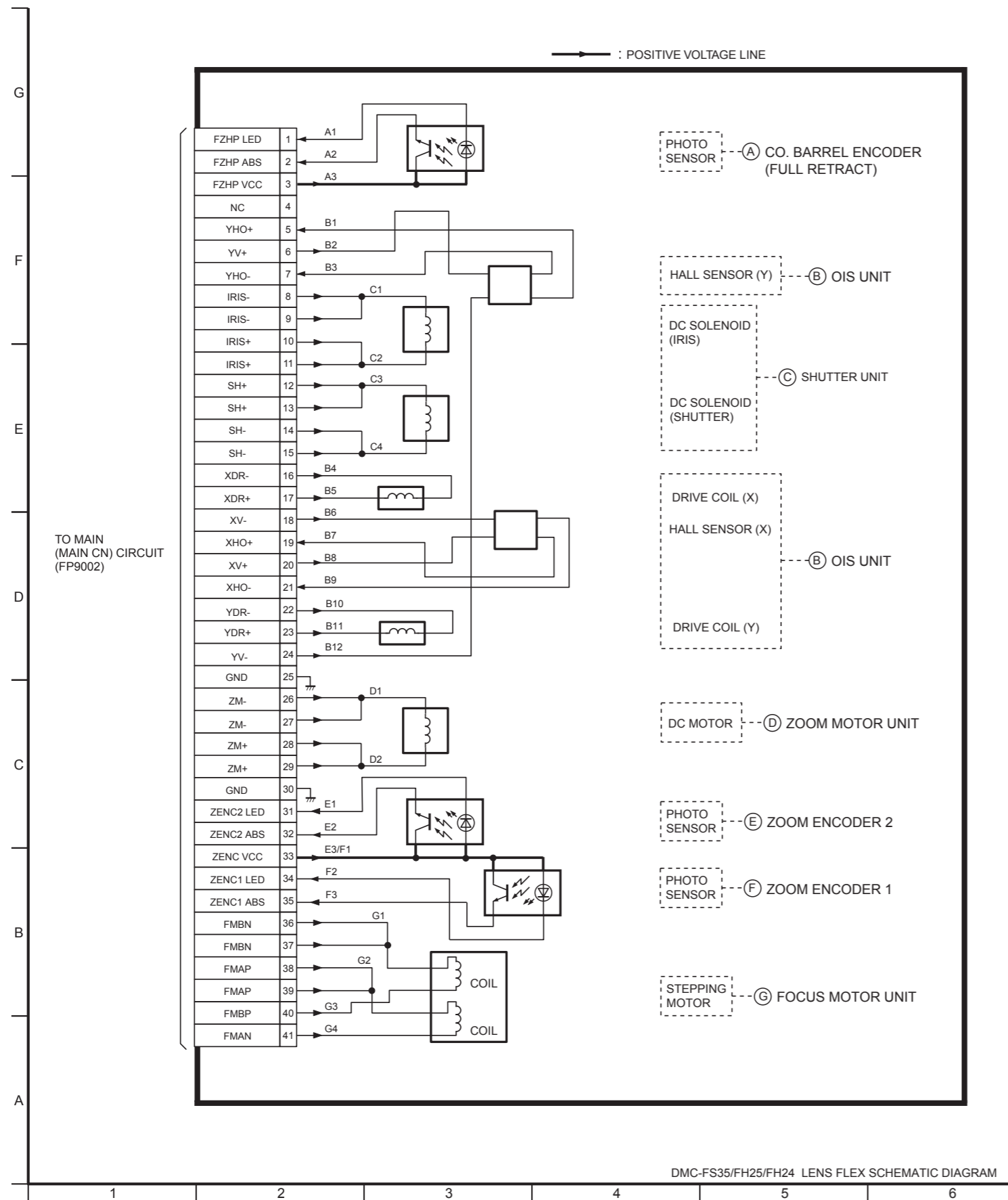

# S5. Print Circuit Board

## S5.1. Flash Top P.C.B.

1/4		DMC-FS35/FH25/FH24 Flash Top P.C.B. (Component Side)

N  
M  
L  
K  
J  
I  
H  
G

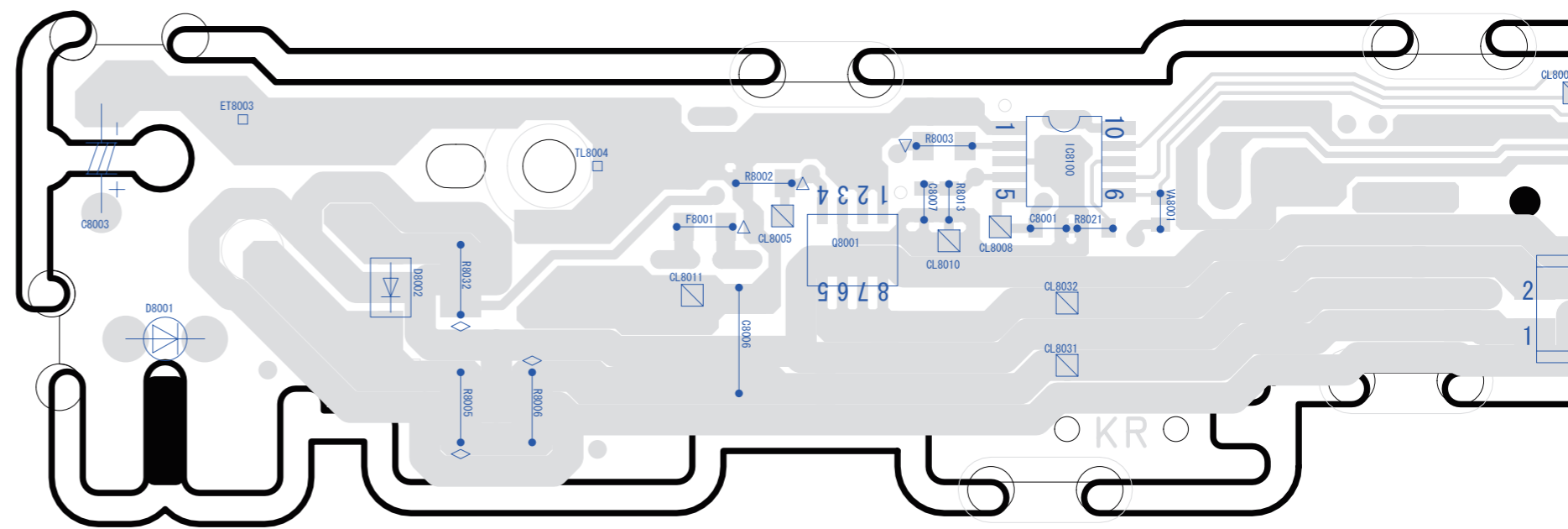

(Component Side)



	2/4	DMC-FS35/FH25/FH24 Flash Top P.C.B. (Component Side)

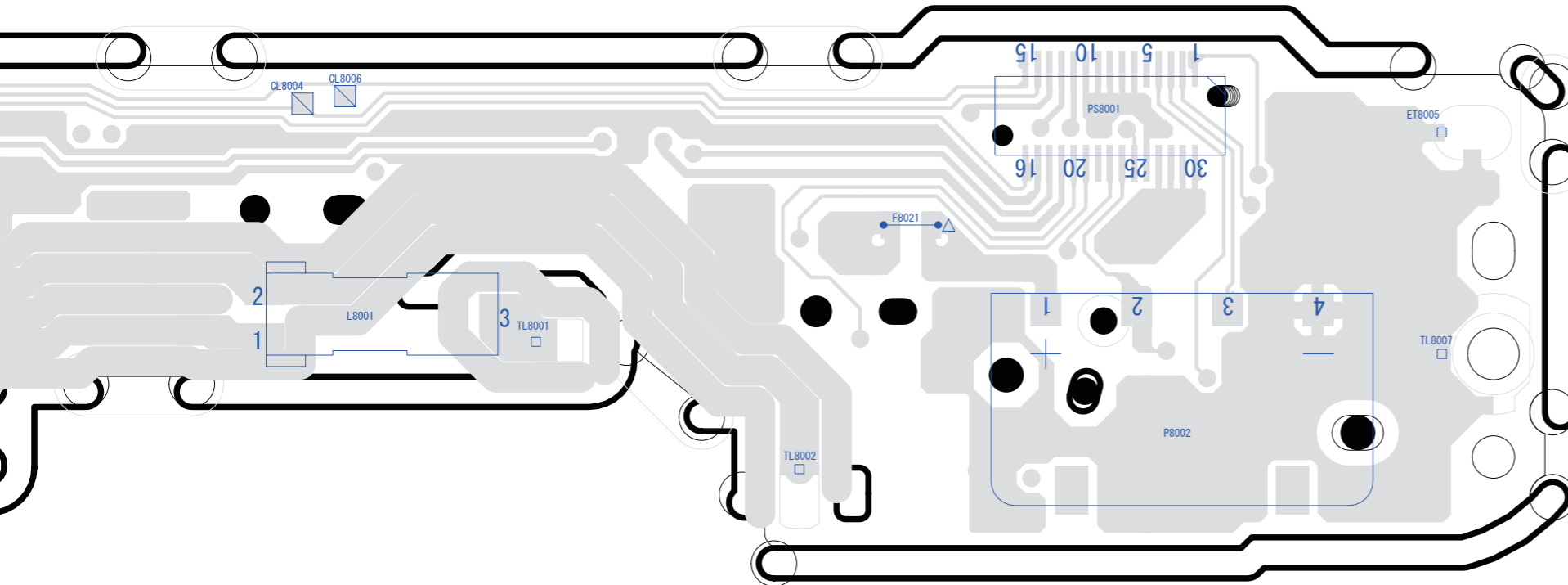

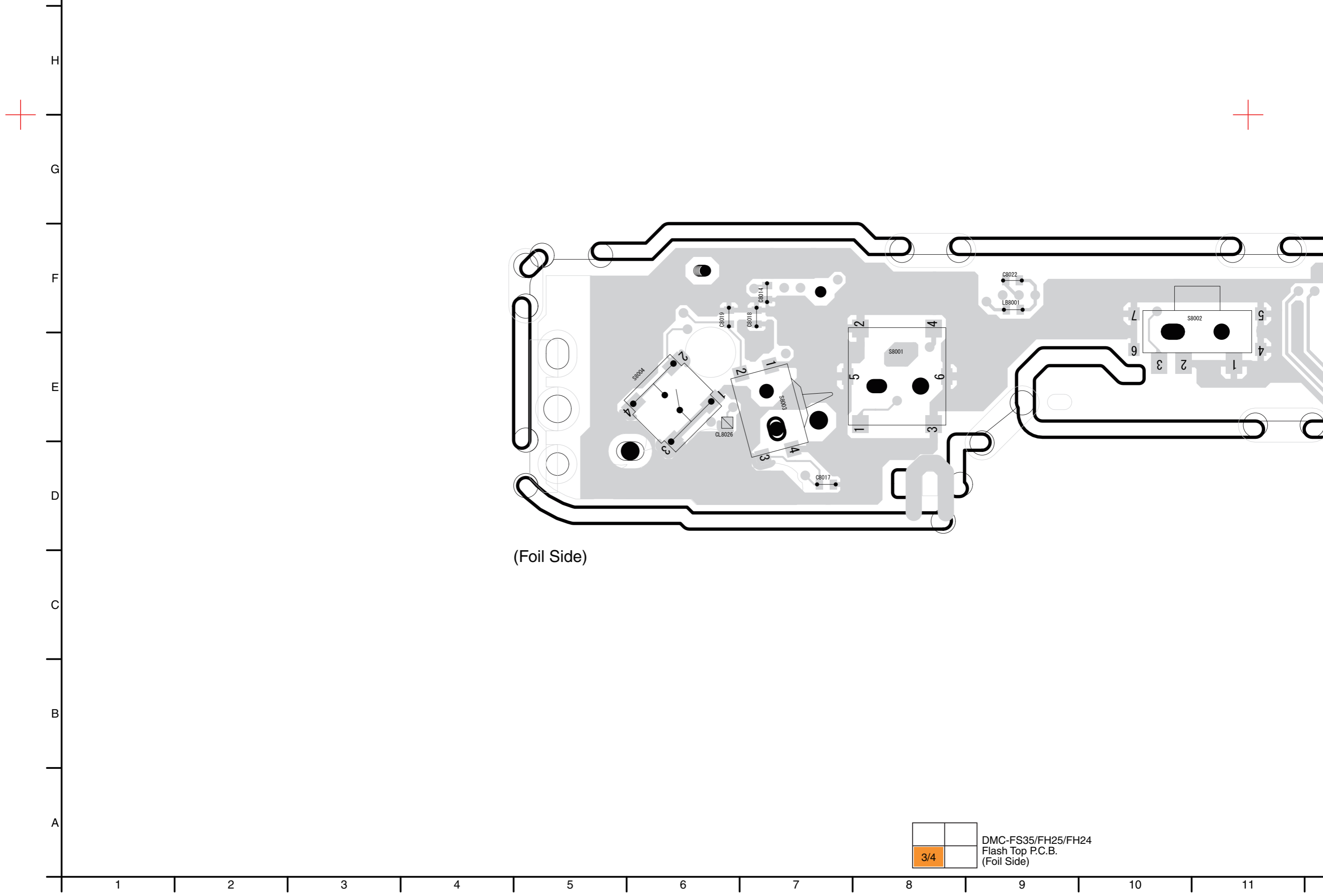

(Foil Side)

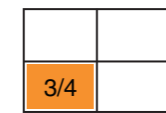

DMC-FS35/FH25/FH24  
Flash Top P.C.B.  
(Foil Side)



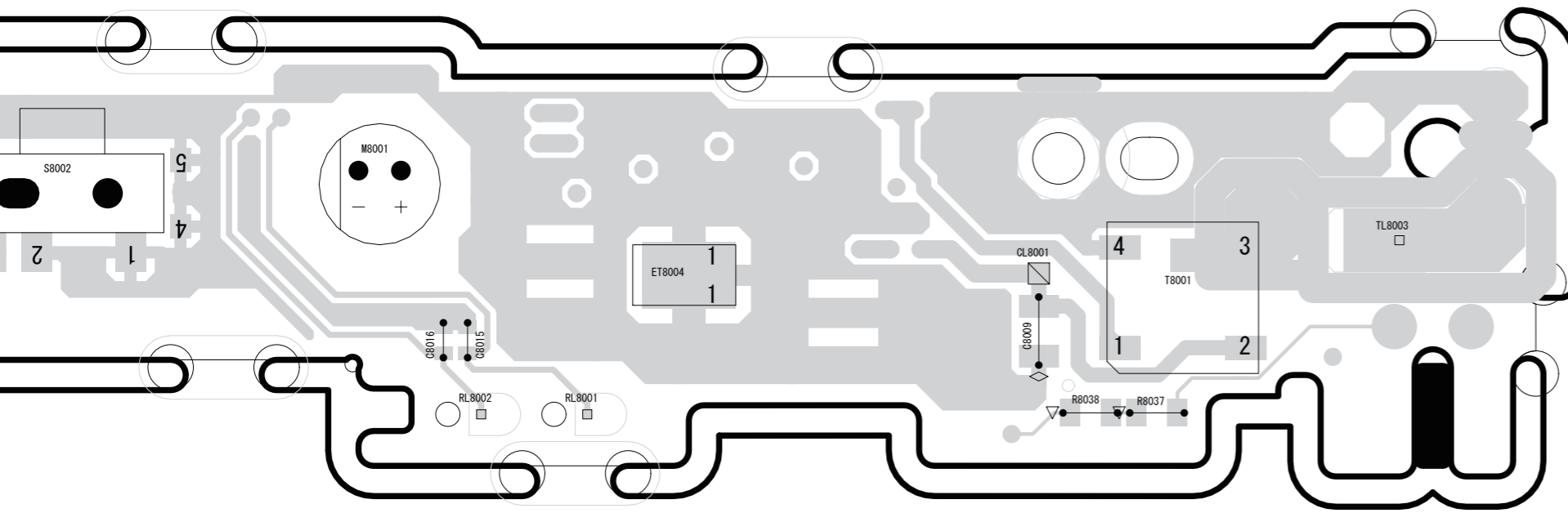

		DMC-FS35/FH25/FH24 Flash Top P.C.B. (Foil Side)
	4/4	

11 | 12 | 13 | 14 | 15 | 16 | 17 | 18 | 19 | 20 | 21

S5.2. CCD Flex P.C.B.

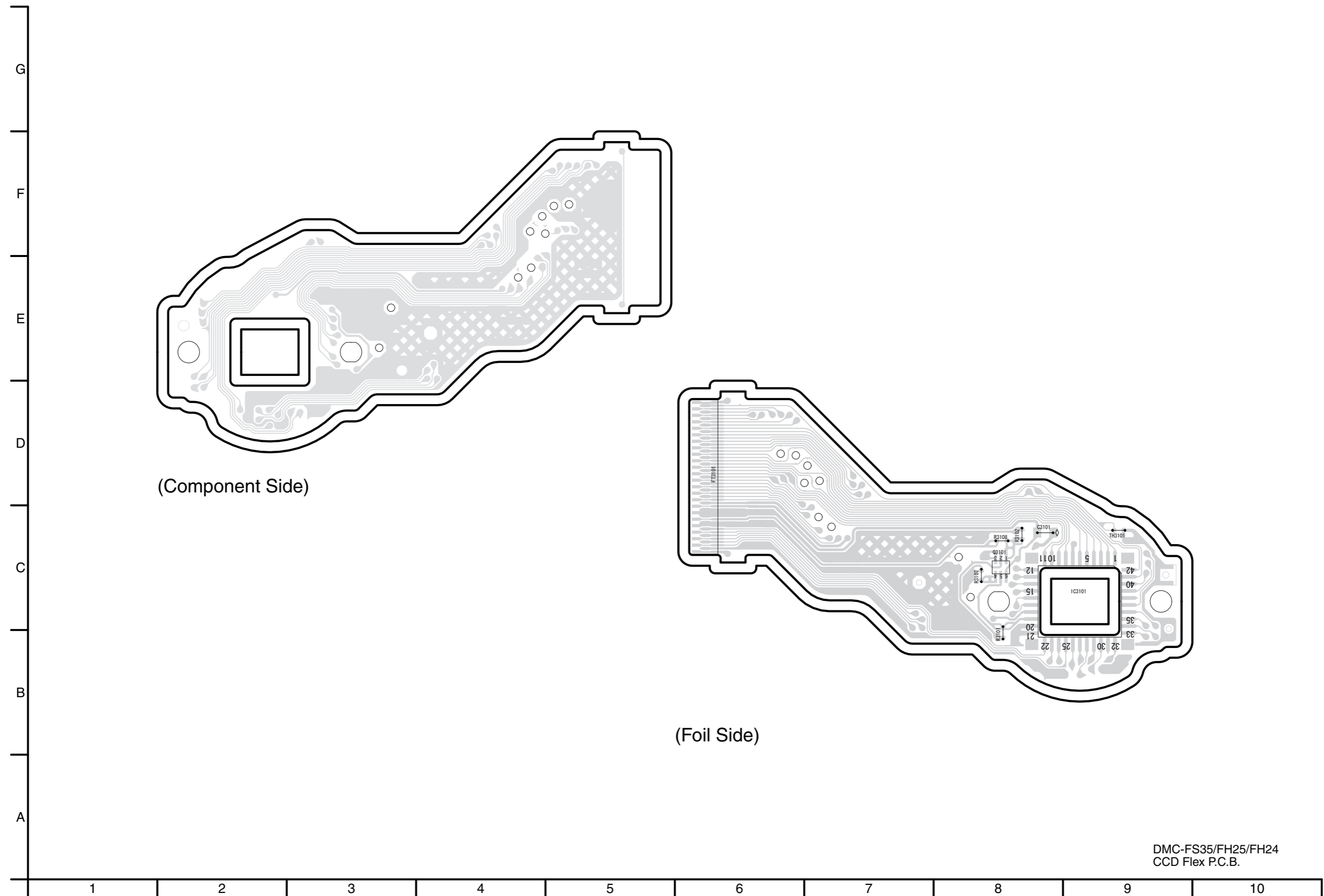

DMC-FS35/FH25/FH24  
CCD Flex P.C.B.

S5.3. Lens Flex P.C.B.

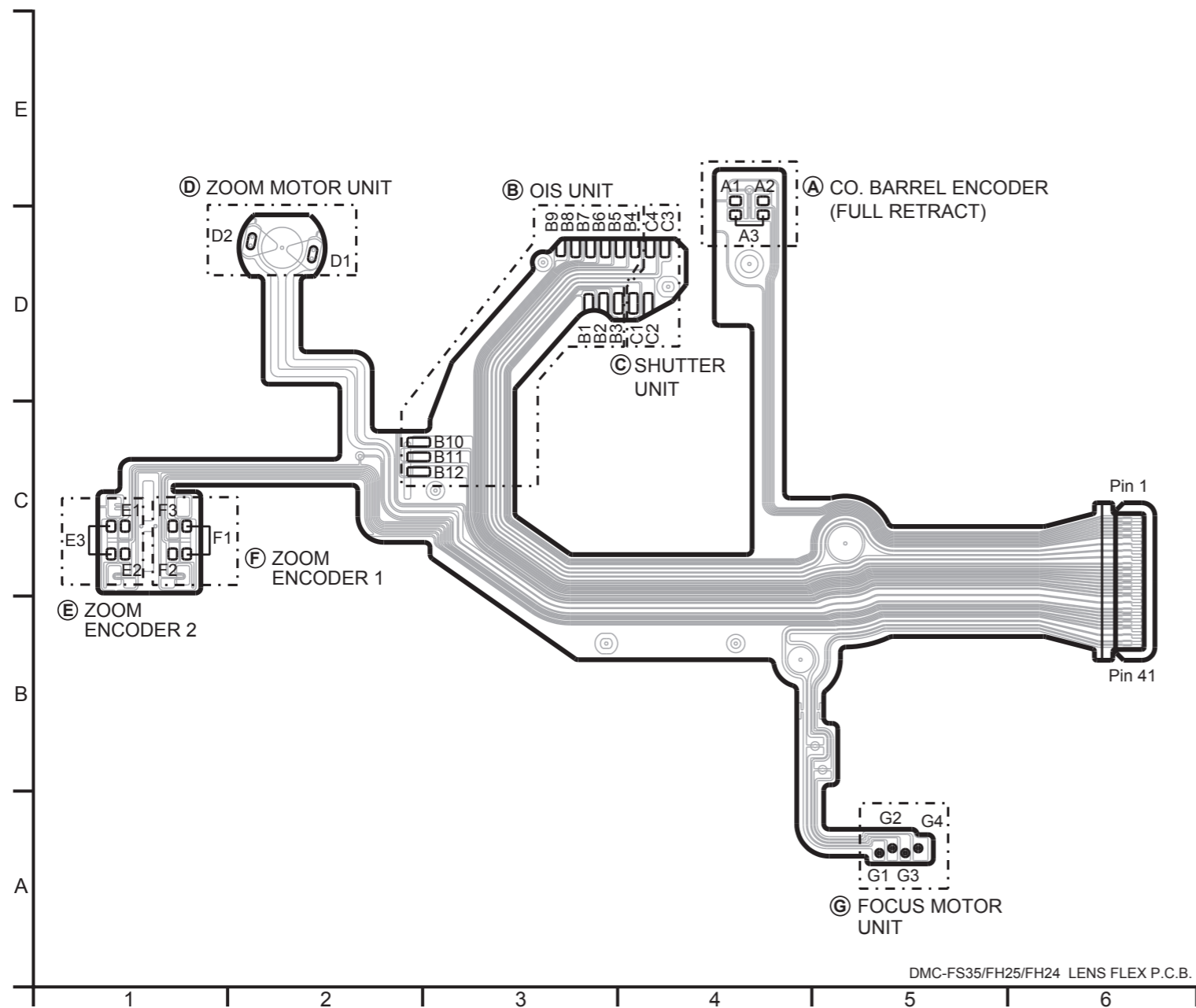



## S6. Replacement Parts List

- Note:
1. \* Be sure to make your orders of replacement parts according to this list.
  2. **IMPORTANT SAFETY NOTICE**  
Components identified with the mark  $\triangle$  have the special characteristics for safety.  
When replacing any of these components, use only the same type.
  3. Unless otherwise specified,  
All resistors are in OHMS, K=1,000 OHMS. All capacitors are in MICRO-FARADS (uf), P=uuF.
  4. The marking (RTL) indicates the retention time is limited for this item. After the discontinuation of this assembly in production, it will no longer be available.
  5. Supply of CD-ROM, in accordance with license protection, is allowable as replacement parts only for customers who accidentally damaged or lost their own.

**E.S.D. standards for Electrostatically Sensitive Devices, refer to PREVENTION OF ELECTROSTATIC DISCHARGE (ESD) TO ELECTROSTATICALLY SENSITIVE (ES) DEVICES section.**

**Definition of Parts supplier:**

1. Parts marked with [ENERGY] in the remarks column are supplied from Panasonic Corporation Energy Company.
2. Parts marked with [SPC] in the remarks column are supplied from AVC-CSC-SPC. Others are supplied from PAVCSG.



DMC-FS35EG-S

Ref.No.	Part No.	Part Name & Description	Pcs	Remarks
1	VEP56126C	MAIN P.C.B.	1	(RTL) E.S.D.
2	VEP58149A	FLASH TOP P.C.B.	1	(RTL) E.S.D.
3	VEP59094A	SUB P.C.B.	1	(RTL) E.S.D.
4	ML-421S/DN	BATTERY	1	(B9101) [ENERGY]
5	VGQ0S76	DPR SHEET	1	
6	VGQ0V76	DPR SHEET	1	
7	VMP9869	FRAME PLATE	1	
8	VYK4N13	FRONT CASE UNIT	1	35EG-S,EP-S,EB-S,EE-S, 25PU-S,GC-S,GH-S,GF-S, GA-S,GK-S,GN-S
8	VYK4N31	FRONT CASE UNIT	1	35EG-K,EP-K,EF-K,EB-K, EE-K, 25PC-K,PU-K,PR-K, GC-K,GH-K,GF-K,GA-K, GT-K,GK-K,GN-K
8	VYK4N32	FRONT CASE UNIT	1	35EG-R,EP-R,EF-R,EB-R, 25PC-R,PU-R,GC-R,GH-R, GF-R,GA-R,GK-R,GN-R
8	VYK4N33	FRONT CASE UNIT	1	35EG-A,EP-A,EB-A,EE-A, PC-A,PU-A,GK-A,GN-A
8	VYK4N34	FRONT CASE UNIT	1	35EG-V,EP-V,EB-V, 25PC-V, PU-V,PR-V,GT-V
8	VYK4N50	FRONT CASE UNIT	1	25P-S
8	VYK4N51	FRONT CASE UNIT	1	25P-K, 24P-K
8	VYK4N52	FRONT CASE UNIT	1	25P-R
8	VYK4N53	FRONT CASE UNIT	1	25P-A
8	VYK4N54	FRONT CASE UNIT	1	25P-V
8-1	VGK3718	LENS RING	1	
9	VYK4N35	REAR CASE UNIT	1	(-S)
9	VYK4N36	REAR CASE UNIT	1	(-K)
9	VYK4N37	REAR CASE UNIT	1	(-R)
9	VYK4N38	REAR CASE UNIT	1	(-A)
9	VYK4N39	REAR CASE UNIT	1	(-V)
9-1	VGU0H57	CURSOR BUTTON	1	
9-2	VGU0H58	SET BUTTON	1	
10	VYK4N40	BATTERY DOOR UNIT	1	(-S)
10	VYK4N41	BATTERY DOOR UNIT	1	(-K)
10	VYK4N42	BATTERY DOOR UNIT	1	(-R)
10	VYK4N43	BATTERY DOOR UNIT	1	(-A)
10	VYK4N44	BATTERY DOOR UNIT	1	(-V)
11	B3ADA0000230	AF LED	1	(D8001) E.S.D.
12	F2A2F8800003	E.CAPACITOR	1	(C8003)
13	L0AA01A00098	SPEAKER	1	
14	L0CBAY000093	MICROPHONE UNIT	1	(M8001)
15	VEK0R28	FLASH UNIT	1	
16	VGL1290	AF PANEL LIGHT	1	
17	VMB4278	C-EARTH SPRING	1	(ET8003)
18	VMP9873	TOP PLATE	1	(ET8005)
19	VMT2136	MIC DUMPER	1	
20	VMT2137	IRIS DUMPER	1	
21	VYK4P46	TOP CASE UNIT	1	35EG,EP,EF,EB,EE
21	VYK4P45	TOP CASE UNIT	1	25P,PC,PU,PR,GC,GH,GF, GA,GT,GK,GN
21	VYK5A18	TOP CASE UNIT	1	24P
21-1	VGQ0J75	POWER KNOB BASE	1	
21-2	VGU0H46	POWER KNOB	1	
21-3	VGU0H66	EZ BUTTON	1	
22	VGQ0M78	BATTERY LOCK KNOB	1	
23	VKF4789	JACK DOOR	1	(-S)
23	VKF4836	JACK DOOR	1	(-K)
23	VKF4837	JACK DOOR	1	(-R)
23	VKF4838	JACK DOOR	1	(-A)
23	VKF4839	JACK DOOR	1	(-V)
24	VMB4152	BATTERY LOCK SPRING	1	
25	VMB4337	BATTERY OUT SPRING	1	
26	VMP9240	TRIPOD	1	
27	VMP9868	FRAME	1	
28	VMP9872	BATTERY CASE	1	
29	VMS7863	BATTERY DOOR SHAFT	1	
30	VMS7863	JACK DOOR SHAFT	1	
31	VYK5C83	LCD UNIT	1	
31-1	VYP9322	LCD PANEL UNIT	1	
32	VGQ0R77	PCB SPACER	1	
33	VGU0F46	MODE KNOB	1	

Ref.No.	Part No.	Part Name & Description	Pcs	Remarks
100	VXW1229	LENS UNIT (W/O CCD)	1	[SPC]
102	VEK0R36	CCD UNIT	1	[SPC] E.S.D.
103	L6DA8DFC0002	ZOOM MOTOR	1	[SPC]
104	VEK0P74	LENS FPC UNIT	1	[SPC]
104-1	B3NBA0000011	PHOTO SENSOR	1	[SPC]
104-2	B3NBA0000011	PHOTO SENSOR	1	[SPC]
104-3	B3NBA0000011	PHOTO SENSOR	1	[SPC]
105	VDW1958	BOTH SIDES CAM FRAME	1	[SPC]
106	VDW1962	2ND 3RD DIRECT FRAME	1	[SPC]
107	VXP3556	1ST LENS FRAME UNIT	1	[SPC]
108	VXP3579	1ST DIRECT FRAME UNIT	1	[SPC]
109	VXP3349	2ND LENS FRAME UNIT	1	[SPC]
110	VXP3350	3RD LENS FRAME UNIT	1	[SPC]
111	VXQ2071	FIX FRAME UNIT	1	[SPC]
112	VXQ2072	MASTER FLANGE UNIT	1	[SPC]
112-1	L6HA64NC0020	FOCUS MOTOR UNIT	1	[SPC]
112-2	VMB4333	FOCUS SPRING	1	[SPC]
112-3	VXP3358	4TH LENS FRAME UNIT	1	[SPC]
113	VXP3560	DRIVE/PENETRAION FRAME UNIT	1	[SPC]
114	VZT0938	TAPE A	1	[SPC]
115	VZT0938	TAPE A	1	[SPC]
116	VZT0939	TAPE B	1	[SPC]
B1	VHD2081	SCREW	1	(-S)
B1	VHD2082	SCREW	1	(-K/R/AV)
B2	VHD2081	SCREW	1	(-S)
B2	VHD2082	SCREW	1	(-K/R/AV)
B3	VHD2081	SCREW	1	(-S)
B3	VHD2082	SCREW	1	(-K/R/AV)
B4	VHD2194	SCREW	1	(-S)
B4	VHD2195	SCREW	1	(-K/R/AV)
B5	VHD2194	SCREW	1	(-S)
B5	VHD2195	SCREW	1	(-K/R/AV)
B6	VHD2194	SCREW	1	(-S)
B6	VHD2195	SCREW	1	(-K/R/AV)
B7	VHD2194	SCREW	1	(-S)
B7	VHD2195	SCREW	1	(-K/R/AV)
B8	VHD2194	SCREW	1	(-S)
B8	VHD2195	SCREW	1	(-K/R/AV)
B9	VHD2194	SCREW	1	(-S)
B9	VHD2195	SCREW	1	(-K/R/AV)
B10	VHD2210	SCREW	1	
B11	VHD1909	SCREW	1	
B12	VHD1909	SCREW	1	
B13	VHD1909	SCREW	1	
B14	VHD1998	SCREW	1	
B15	VHD1998	SCREW	1	
B16	VHD2004	SCREW	1	
B17	XQN16+BJ7FN	SCREW	1	
B18	XQN16+BJ7FN	SCREW	1	
B19	XQN16+BJ7FN	SCREW	1	
B101	VHD1871	SCREW	1	[SPC]
B102	VHD1871	SCREW	1	[SPC]
B103	VHD2011	SCREW	1	[SPC]
B104	VHD2296	SCREW	1	[SPC]
B105	VHD2296	SCREW	1	[SPC]
B106	VHD2296	SCREW	1	[SPC]
B107	VHD2296	SCREW	1	[SPC]
B108	VHD2296	SCREW	1	[SPC]
B109	VHD2296	SCREW	1	[SPC]
B110	VHD2296	SCREW	1	[SPC]
B111	VHD2296	SCREW	1	[SPC]





DMC-FS35EG-S

Ref.No.	Part No.	Part Name & Description	Pcs	Remarks	Ref.No.	Part No.	Part Name & Description	Pcs	Remarks
300	VPF1372-A	CAMERA BAG	1	EXCEPT P,PC,PU	△ 313	VQT3D45	BASIC O/I (CHINESE(TRADITIONAL))	1	25GT
△ 301	DE-A92AA/SX	BATTERY CHARGER	1	35EG,EP,EF,EB,EE, 25GN	△ 313	VQT3D46	BASIC O/I (CHINESE(SIMPLIFIED))	1	25GK
△ 301	DE-A92DA/SX	BATTERY CHARGER	1	25PR	△ 313	VQT3D47	BASIC O/I (ENGLISH)	1	25GN
△ 301	DE-A92BA/SX	BATTERY CHARGER	1	25GH,GF,GA,GK	314	VPK4674	PACKING CASE	1	35EG-S,EP-S,EB-S,EE-S
△ 301	DE-A92CA/SX	BATTERY CHARGER	1	25GT	314	VPK4679	PACKING CASE	1	35EG-K,EP-K,EF-K,EB-K, EE-K
△ 301	DE-A92BA	BATTERY CHARGER	1	25GC [SPC]	314	VPK4684	PACKING CASE	1	35EG-R,EP-R,EF-R,EB-R
△ 302	-----	BATTERY	1	EXCEPT P,PC,PU	314	VPK4689	PACKING CASE	1	35EG-A,EP-A,EB-A,EE-A
304	K1HY08YY0019	USB CABLE W/PLUG	1	EXCEPT P,PC,PU	314	VPK4694	PACKING CASE	1	35EG-V,EP-V,EB-V
305	K1HY08YY0020	AV CABLE W/PLUG	1	EXCEPT P,PC,PU	314	VPK4680	PACKING CASE	1	25PR-K,GH-K,GA-K,GT-K, GN-K
306	VFC4297-B	HAND STRAP	1	EXCEPT P,PC,PU	314	VPK4695	PACKING CASE	1	25PR-V,GT-V
308	VPF1378	BAG, POLYETHYLENE	1	EXCEPT P,PC,PU	314	VPK4675	PACKING CASE	1	25GH-S,GA-S,GN-S
△ 311	VFF0727-S	CD-ROM (SOFT/INSTRUCTION BOOK)	1	35EG,EP,EF,EB [SPC] See "Notes"	314	VPK4685	PACKING CASE	1	25GH-R,GA-R,GN-R
△ 311	VFF0728-S	CD-ROM (SOFT/INSTRUCTION BOOK)	1	35EE [SPC] See "Notes"	314	VPK4676	PACKING CASE	1	25GF-S
△ 311	VFF0729-S	CD-ROM (SOFT/INSTRUCTION BOOK)	1	25GH,GF,GA,GT,GN [SPC] See "Notes"	314	VPK4681	PACKING CASE	1	25GF-K
△ 311	VFF0730-S	CD-ROM (SOFT/INSTRUCTION BOOK)	1	25GK [SPC] See "Notes"	314	VPK4686	PACKING CASE	1	25GF-R
△ 311	VFF0726-S	CD-ROM (SOFT/INSTRUCTION BOOK)	1	25PR [SPC] See "Notes"	314	VPK4697	PACKING CASE	1	25GK-S
△ 311	VFF0794-S	CD-ROM (SOFT/INSTRUCTION BOOK)	1	25GC [SPC] See "Notes"	314	VPK4698	PACKING CASE	1	25GK-K
312	VQC8057	O/I SOFTWARE (GERMAN/FRENCH/ITALIAN/ DUTCH/SPANISH/ PORTUGUESE/TURKISH)	1	35EG	314	VPK4699	PACKING CASE	1	25GK-R
312	VQC8058	O/I SOFTWARE (FINNISH/SWEDISH/DANISH/ POLISH/CZECH/HUNGARIAN)	1	35EP	314	VPK4700	PACKING CASE	1	25GK-A
312	VQC8059	O/I SOFTWARE (FRENCH)	1	35EF	314	VPK4690	PACKING CASE	1	25GN-A
312	VQC8060	O/I SOFTWARE (ENGLISH)	1	35EB, 25GN	314	VPK4918	PACKING CASE	1	25GC-K [SPC]
312	VQC8061	O/I SOFTWARE (RUSSIAN/UKRAINIAN)	1	35EE	314	VPK4917	PACKING CASE	1	25GC-S [SPC]
312	VQC8062	O/I SOFTWARE (ENGLISH/ CHINESE(TRADITIONAL)/ ARABIC/PERSIAN)	1	25GC,GH,GF,GA	314	VPK4919	PACKING CASE	1	25GC-R [SPC]
312	VQC8063	O/I SOFTWARE (CHINESE(TRADITIONAL))	1	25GT	315	VPN7164	CUSHION	1	35EG,EP,EF,EB,EE, 25PR, GC,GH,GF,GA,GT,GK,GN
312	VQC8064	O/I SOFTWARE (CHINESE(SIMPLIFIED))	1	25GK	△ 319	K2CT3YY00034	AC CORD W/PLUG	1	35EB, 25GH
312	VQC8056	O/I SOFTWARE (SPANISH/PORTUGUESE)	1	25PR	△ 319	K2CT39A00002	AC CORD W/PLUG	1	25GC [SPC]
△ 313	VQT3D33	BASIC O/I (GERMAN/FRENCH)	1	35EG	△ 320	K2CQ2YY00082	AC CORD W/PLUG	1	35EG,EP,EF,EE, 25GF,GA
△ 313	VQT3D34	BASIC O/I (ITALIAN/DUTCH)	1	35EG	△ 321	K2CJ2YY00052	AC CORD W/PLUG	1	25GN
△ 313	VQT3D35	BASIC O/I (SPANISH/PORTUGUESE)	1	35EG	△ 322	K2CA2YY00129	AC CORD W/PLUG	1	25GT
△ 313	VQT3D36	BASIC O/I (TURKISH)	1	35EG	△ 322	K2CA2YY00130	AC CORD W/PLUG	1	25GK
△ 313	VQT3D37	BASIC O/I (SWEDISH/DANISH)	1	35EP	△ 323	K2CJ2YY00053	AC CORD W/PLUG	1	25PR
△ 313	VQT3D38	BASIC O/I (POLISH/CZECH)	1	35EP	325	VQL2C68-1A	TAIWAN OPE LABEL	1	25GT
△ 313	VQT3D39	BASIC O/I (HUNGARIAN/FINNISH)	1	35EP					
△ 313	VQT3D40	BASIC O/I (FRENCH)	1	35EF					
△ 313	VQT3D41	BASIC O/I (ENGLISH)	1	35EB					
△ 313	VQT3D42	BASIC O/I (RUSSIAN/UKRAINIAN)	1	35EE					
△ 313	VQT3D32	BASIC O/I (SPANISH)	1	25PR					
△ 313	VQT3D43	BASIC O/I (ENGLISH/ CHINESE(TRADITIONAL))	1	25GC,GH,GF,GA					
△ 313	VQT3D44	BASIC O/I (ARABIC/PERSIAN)	1	25GC,GF					
△ 313	VQT3M09	BASIC O/I (VIETNAMESE)	1	25GA					

# S7. Exploded View

## S7.1. Frame and Casing Section

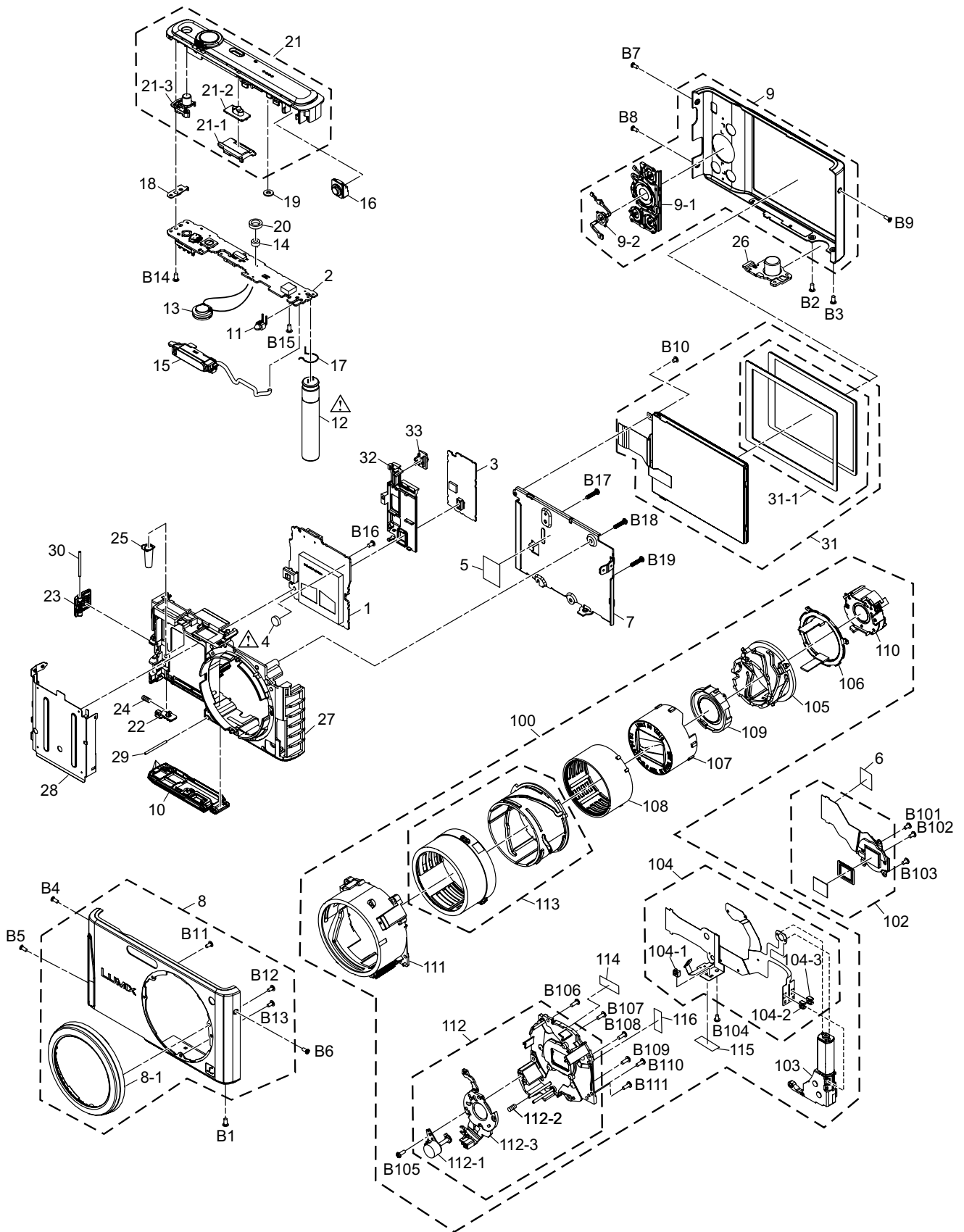

## S7.2. Packing Parts and Accessories Section (1)

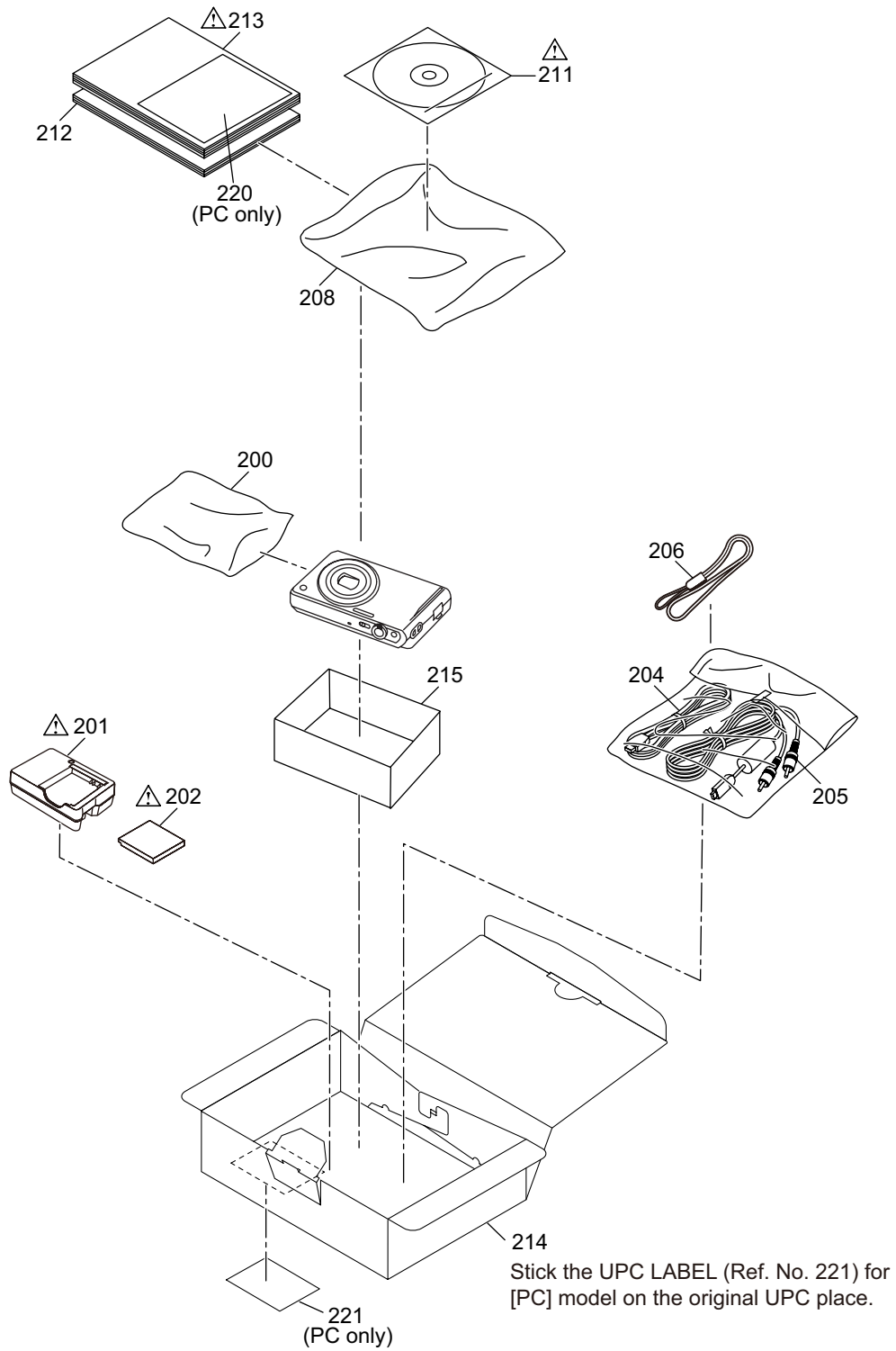

### S7.3. Packing Parts and Accessories Section (2)

